

The effective technology

Farmet[®]

ⒸZ KATALOG NÁHRADNÍCH DÍLŮ ⒸB CATALOGUE OF SPARE PARTS ⒸD ERSATZTEILLISTE
ⒸRU КАТАЛОГ ЗАПАСНЫХ ЧАСТЕЙ ⒸF CATALOGUE DES PIÈCES DE RECHANGE ⒸPL KATALOG CZĘŚCI ZAMIENNYCH

КОМПАКТОМАТ K1000PS

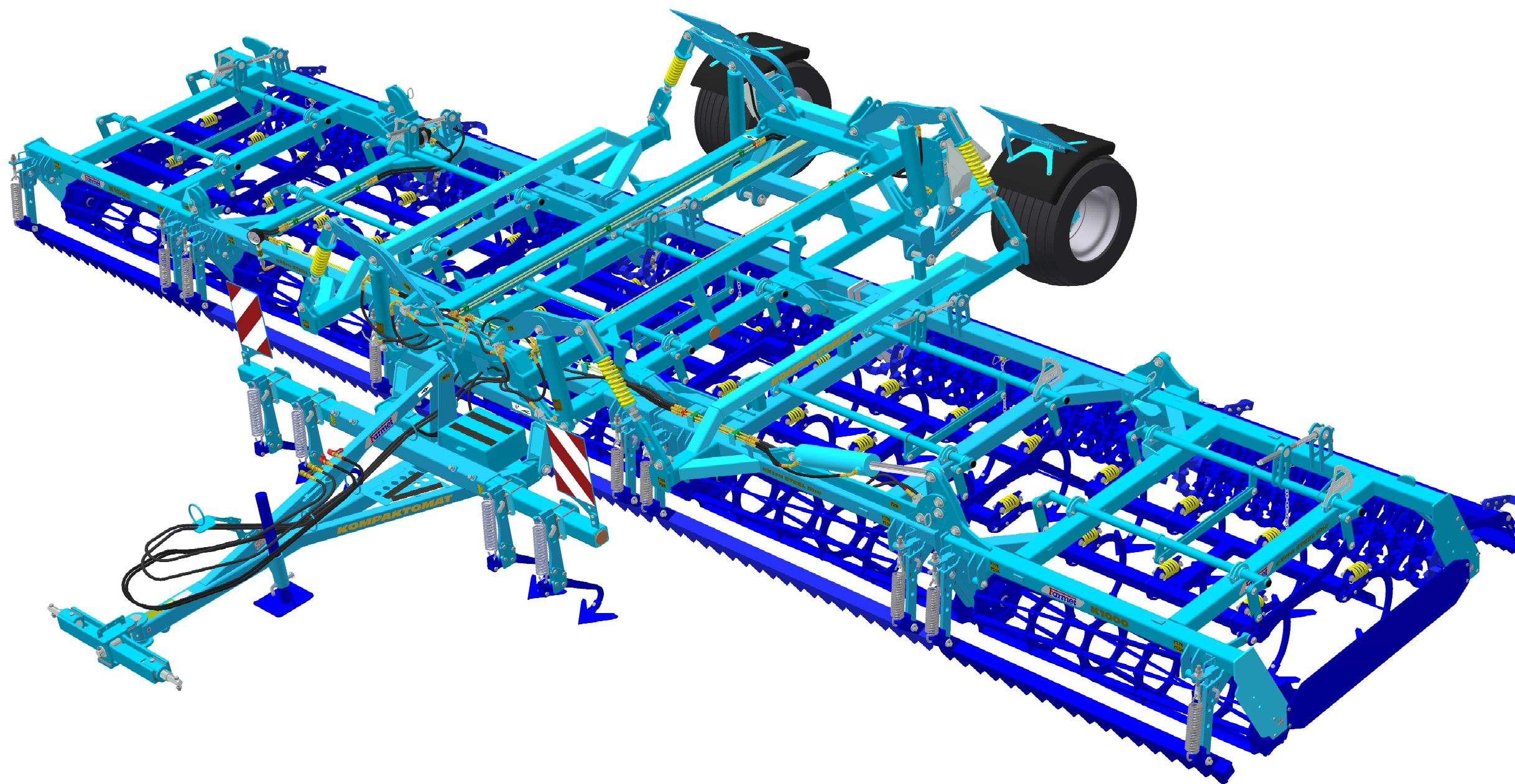

ⒸZ Platnost pro vrcholové | výrobní číslo stroje ⒸB Validity for the top | serial number of the machine
ⒸD Gültigkeit für die Haupt- | Herstellungsnummer der Maschine ⒸRU Действительно для главного | заводского номера машины
ⒸF Validité du numéro de référence | de série de la machine ⒸPL Obowiązuje dla numeru głównego | seryjnego maszyny

9303983 | 2016/0929

Farmet a. s.
Jiřínková 276
552 03 Česká Skalice, CZ

telefon: +420 491 450 111
fax: +420 491 450 136
GSM: +420 774 715 738

IČ: 46504931
DIČ: CZ46504931

web: www.farmet.cz
e-mail: farmet@farmet.cz

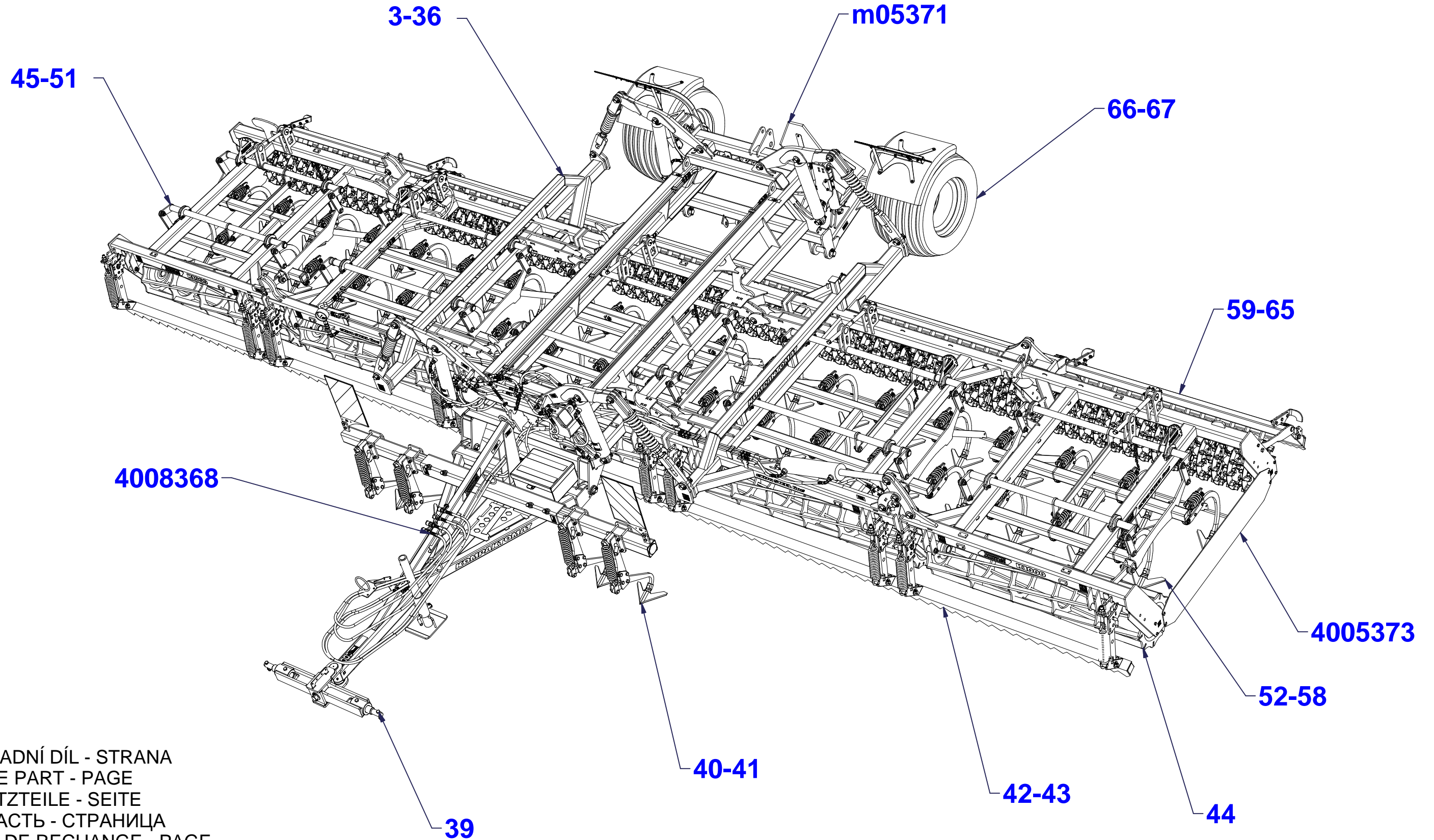

Ⓒ POLOTOVAR STROJE

Ⓓ MASCHINEN-HALBFABRIKAT

Ⓕ MACHINE - SEMI-PRODUIT

Ⓖ SEMIFINISHED MACHINE

Ⓡ ПОЛУФАБРИКАТ МАШИНЫ

Ⓟ PÓLFABRYKAT MASZYNY



3007967

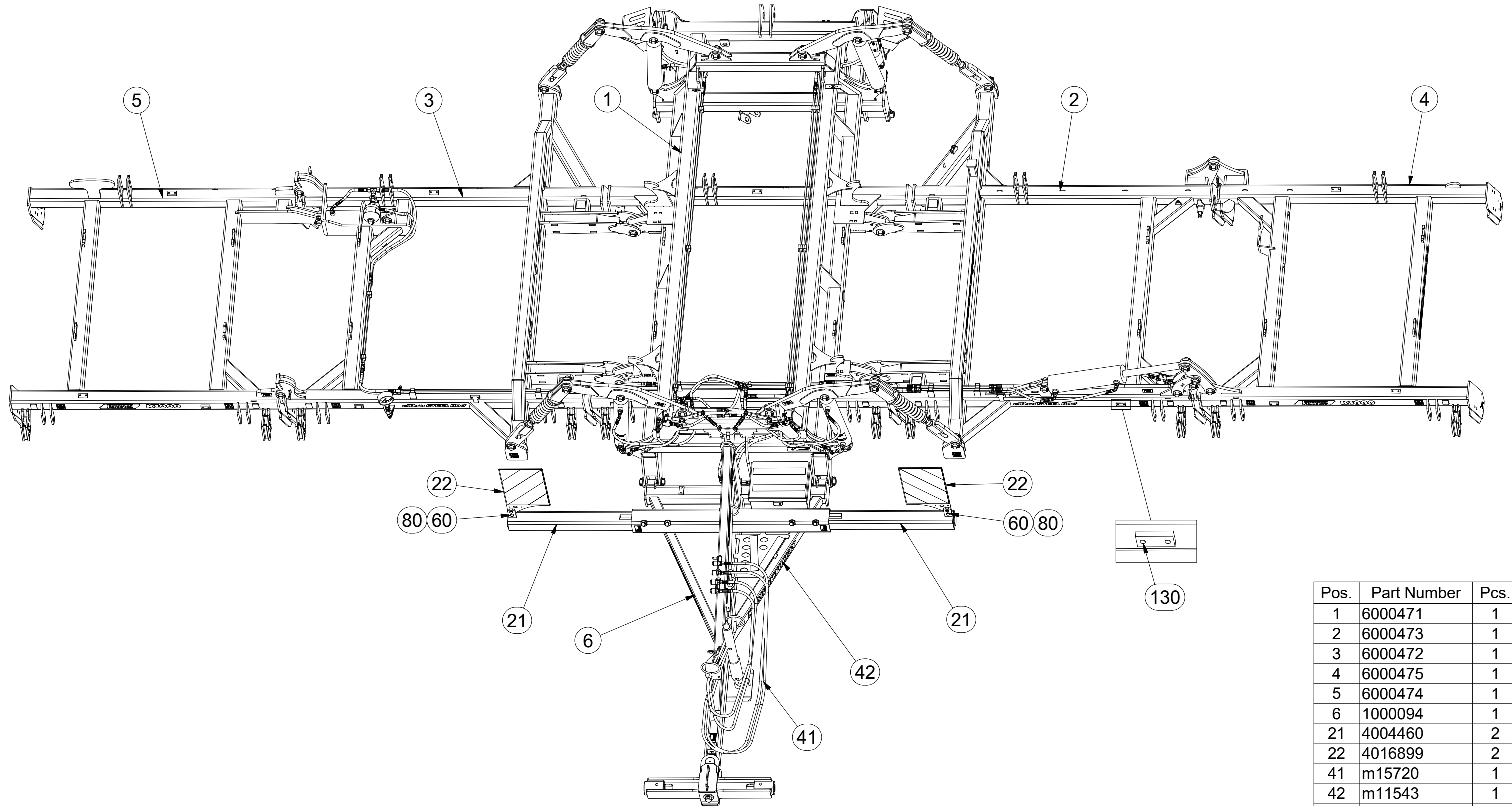

Pos.	Part Number	Pcs.
1	6000471	1
2	6000473	1
3	6000472	1
4	6000475	1
5	6000474	1
6	1000094	1
21	4004460	2
22	4016899	2
41	m15720	1
42	m11543	1
60	m04039	4
80	m04301	10
130	m11099	28

Ⓒ POLOTOVAR STROJE

Ⓓ MASCHINEN-HALBFABRIKAT

Ⓕ MACHINE - SEMI-PRODUIT

Ⓖ SEMIFINISHED MACHINE

Ⓡ ПОЛУФАБРИКАТ МАШИНЫ

Ⓟ ПОЉФАБРИКАТ МАСЗЫНЫ



3007967

Pos.	Part Number	Pcs.	Pos.	Part Number	Pcs.
6	1000094	1	50	m10454	1
7	3003787	1	61	m03681	5
21	4004460	2	67	m14008	6
22	4016899	2	80	m04301	10
24	3003789	1	82	m02533	1
25	4003744	2	84	m03775	93
26	4008049	1	90	m03866	1
27	4014570	1	94	4013139	6
30	m08386	1	102	m10869	1
31	8000647-40207	1	110	m03959	1
42	m11543	1	120	m10451	1
43	4009044	1	130	m11099	28

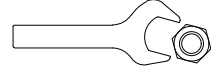
	
M6 (8.8) - 10Nm	
M8 (8.8) - 25Nm	
M10 (8.8) - 50Nm	
M12 (8.8) - 87Nm	
M16 (8.8) - 210Nm	

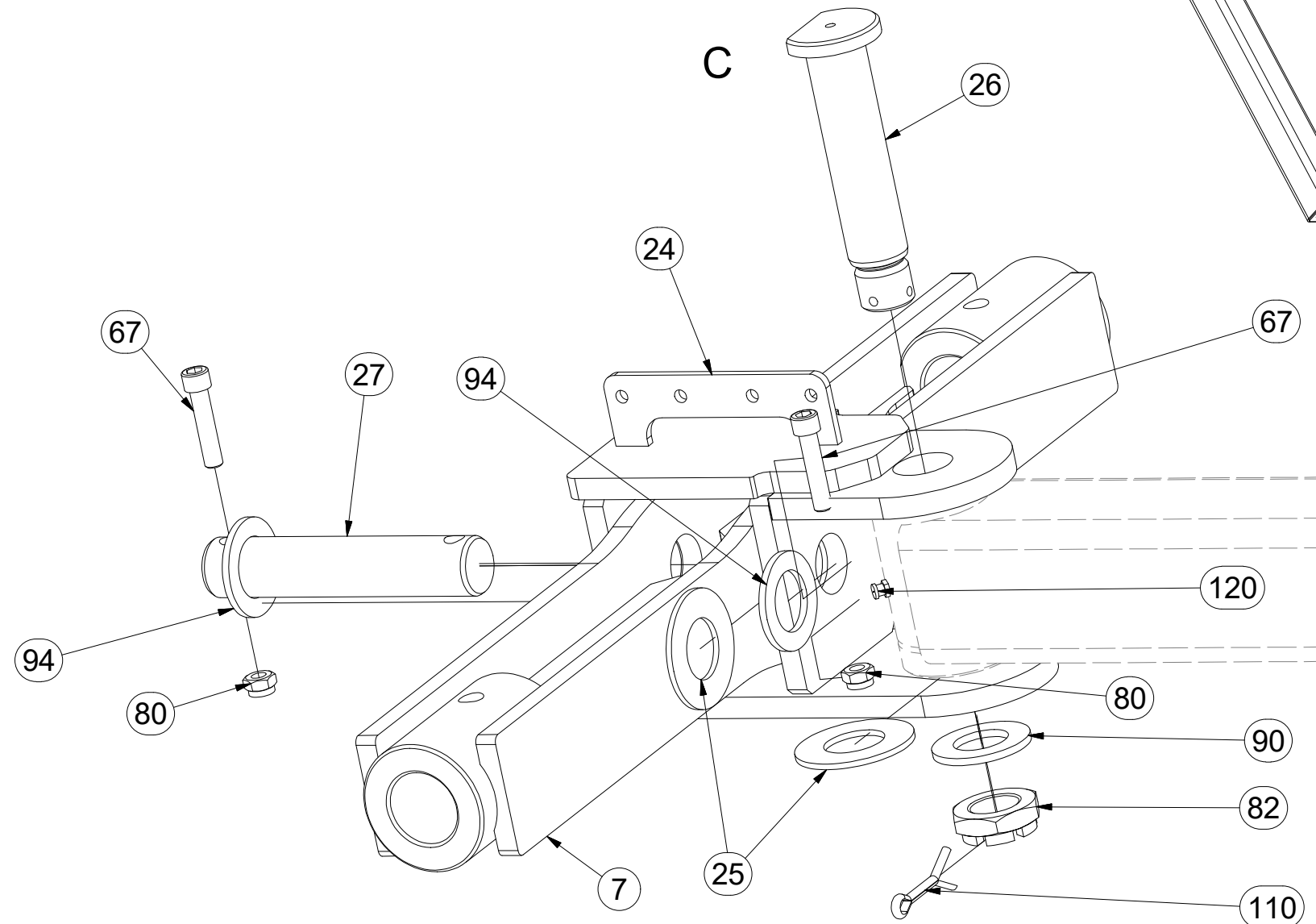
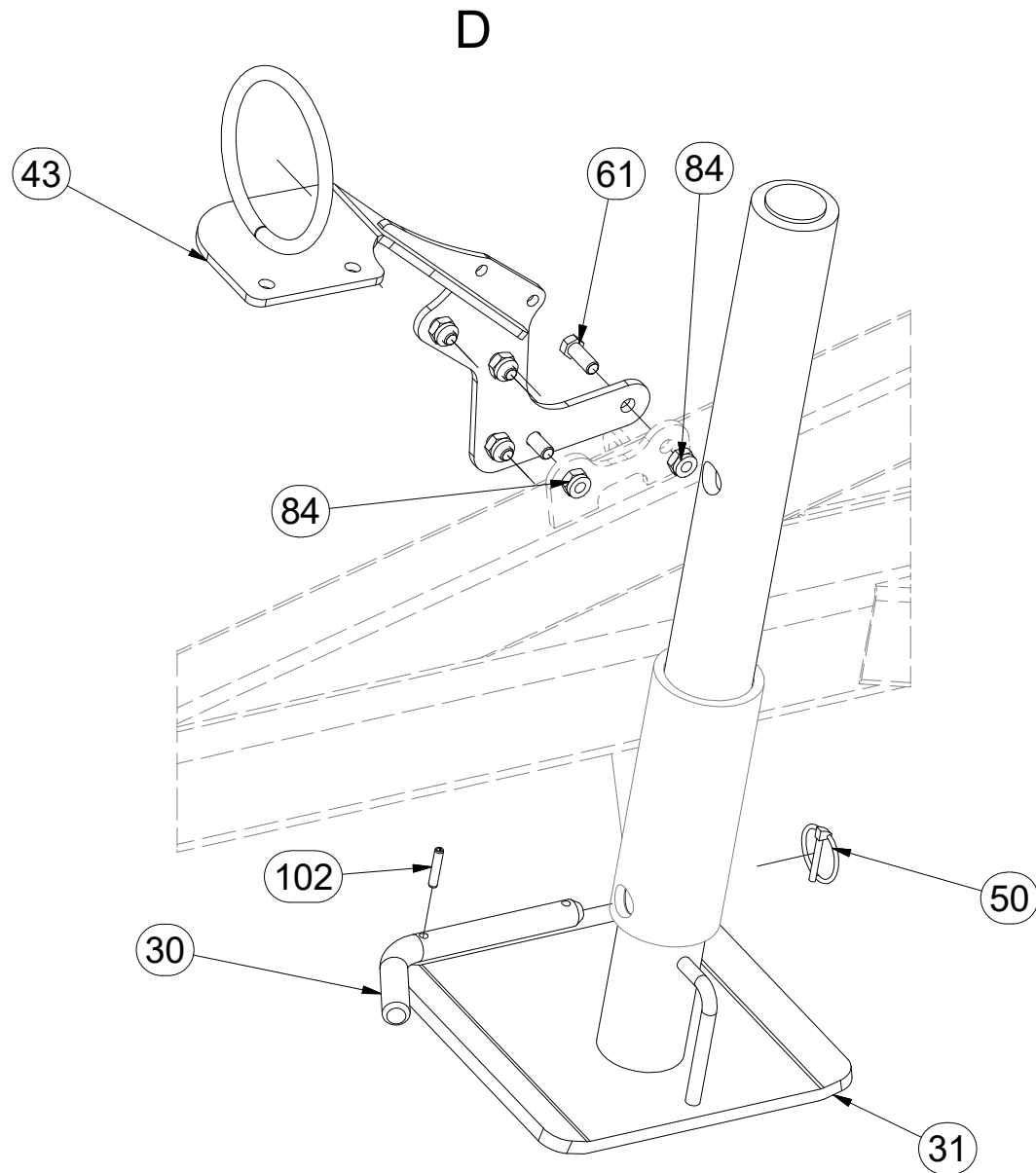
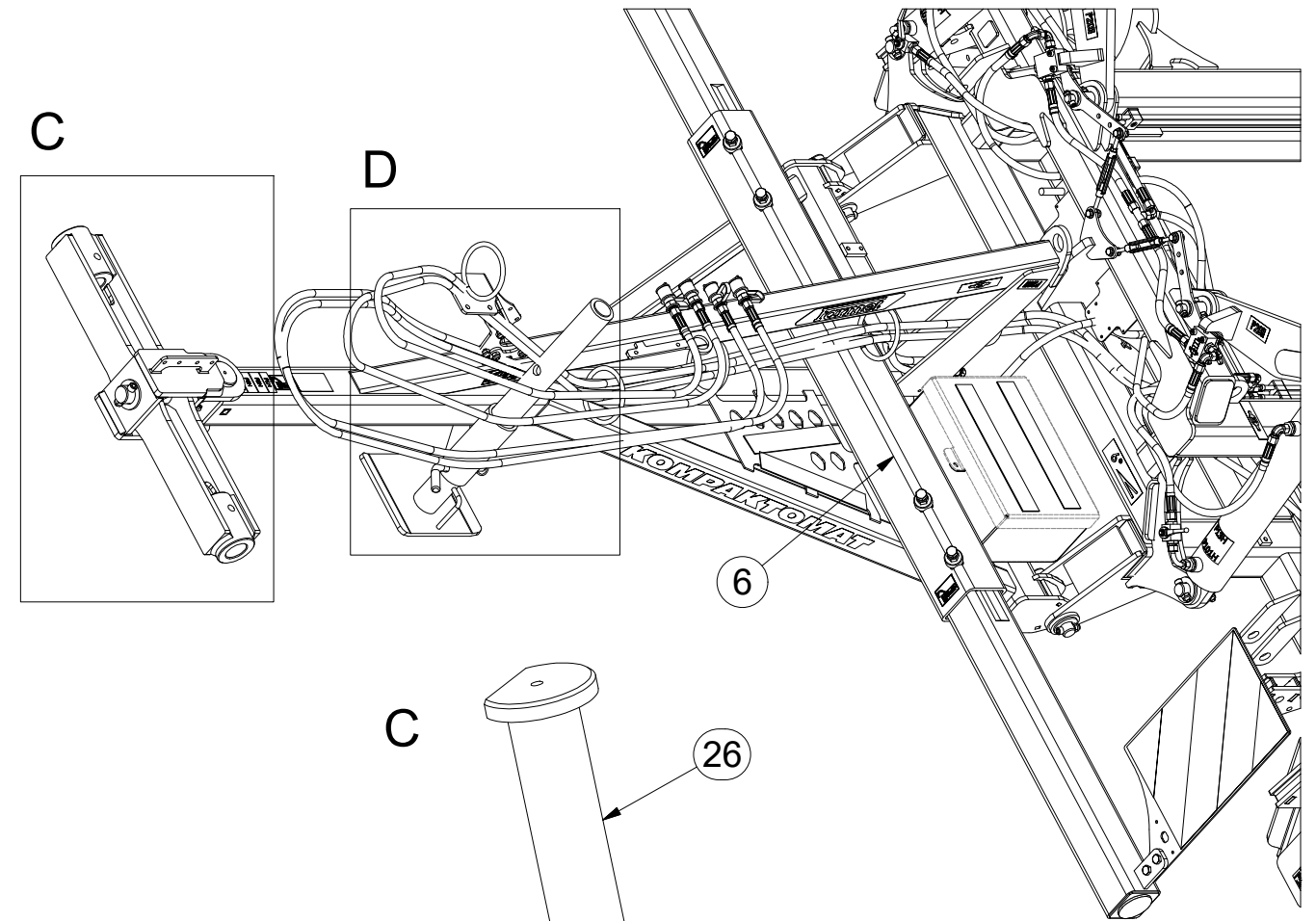

Ⓒ POLOTOVAR STROJE

Ⓓ MASCHINEN-HALBFABRIKAT

Ⓕ MACHINE - SEMI-PRODUIT

Ⓖ SEMIFINISHED MACHINE

Ⓡ ПОЛУФАБРИКАТ МАШИНЫ

Ⓟ PÓŁFABRYKAT MASZYN



3007967

Pos.	Part Number	Pcs.
6	1000094	1
21	4004460	2
22	4016899	2
35	m12296	1
39	4011050	2
60	m04039	4
63	m02254	4
66	m01092	3
69	m14143	82
80	m04301	10
81	m01306	4
84	m03775	93
86	m04503	18
92	m07936	3
95	m14029	82
133	m02579	6

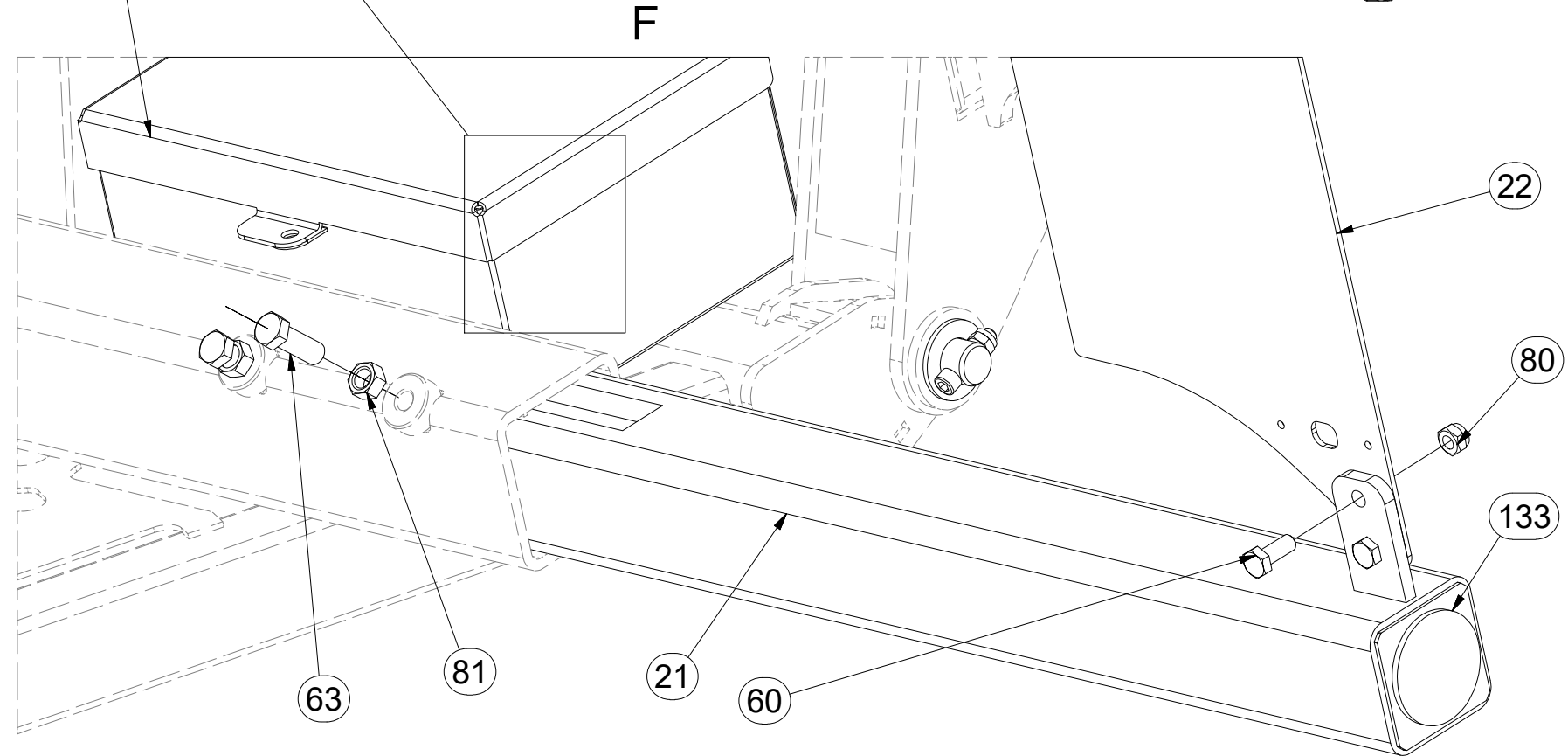
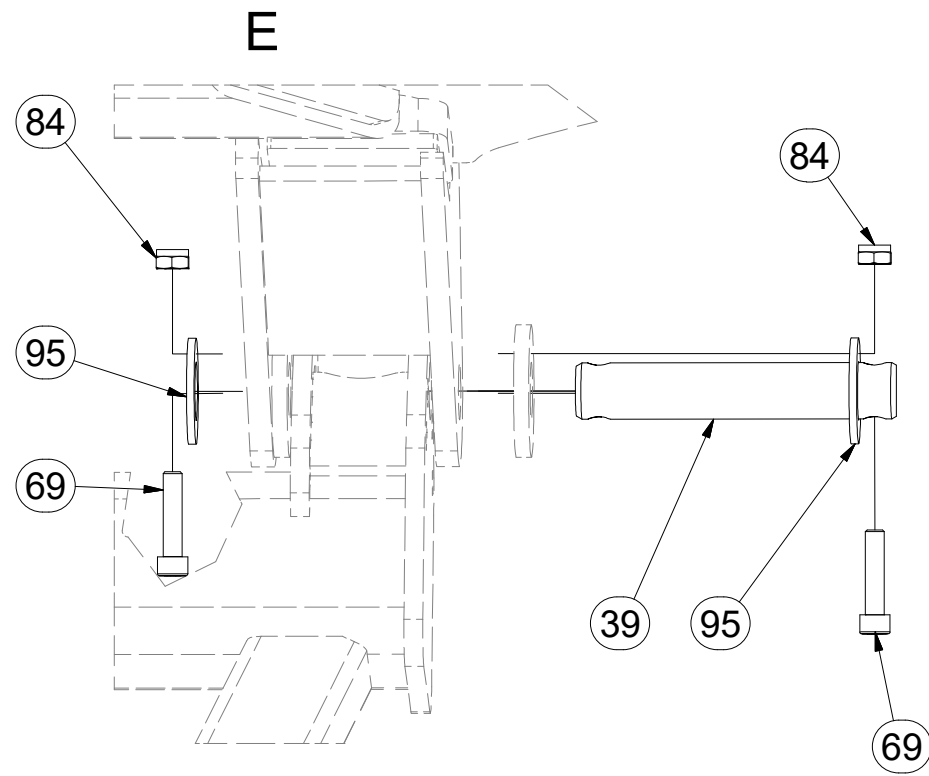
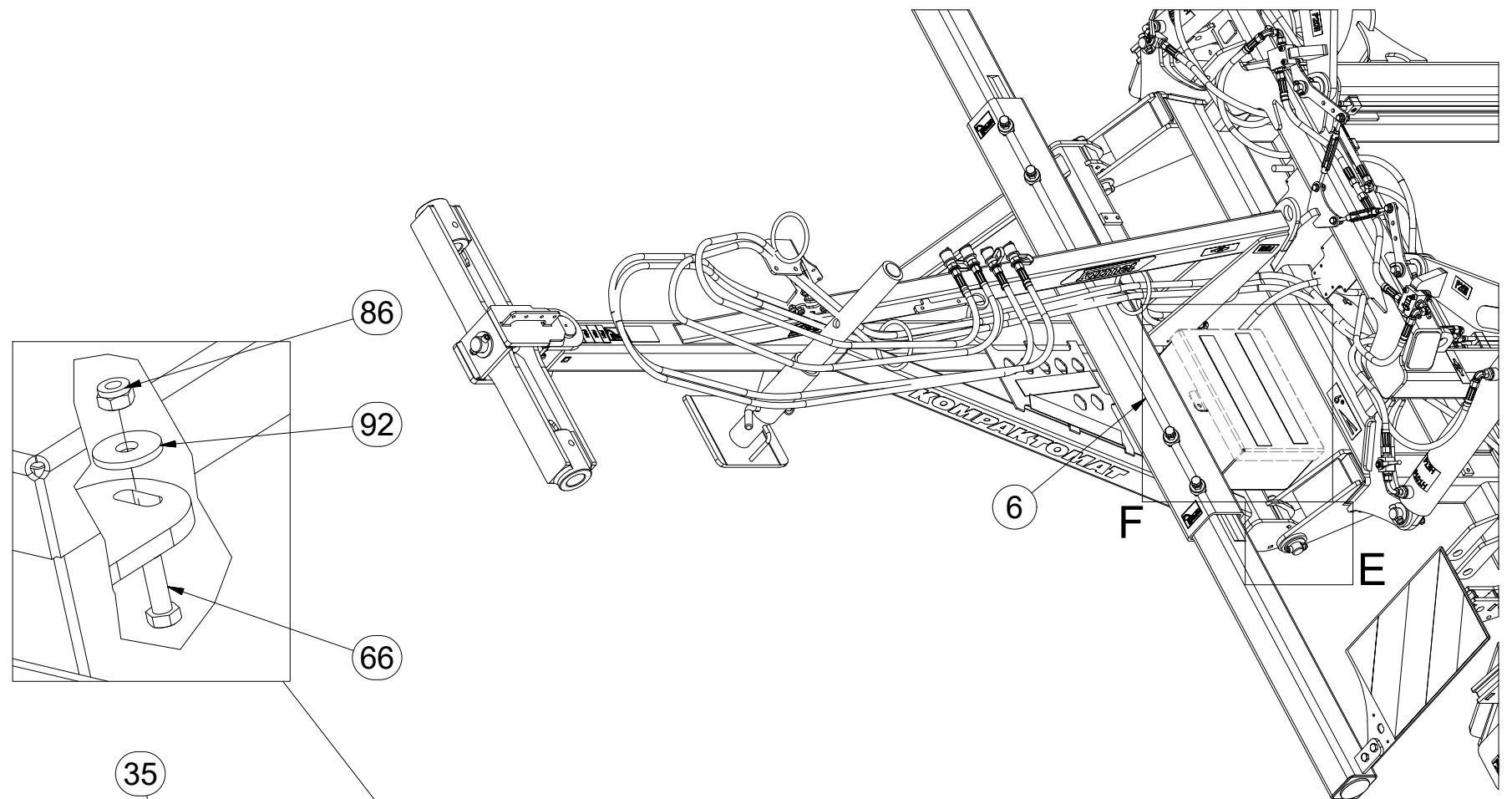
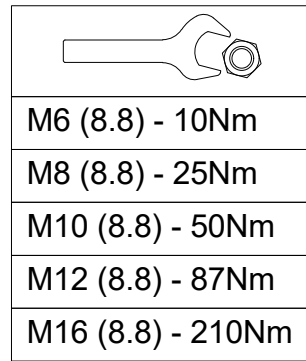

Ⓒ POLOTOVAR STROJE

Ⓓ MASCHINEN-HALBFABRIKAT

Ⓕ MACHINE - SEMI-PRODUIT

Ⓖ SEMIFINISHED MACHINE

Ⓡ ПОЛУФАБРИКАТ МАШИНЫ

Ⓢ РÓŁФАБРЫКАТ МАСЗЫНЫ



3007967

Pos.	Part Number	Pcs.
21	4004460	2
22	4016899	2
39	4011050	2
44	4013461	1
60	m04039	4
63	m02254	4
68	m01074	2
69	m14143	82
80	m04301	10
81	m01306	4
84	m03775	93
87	m05560	4
95	m14029	82
130	m11099	28
133	m02579	6

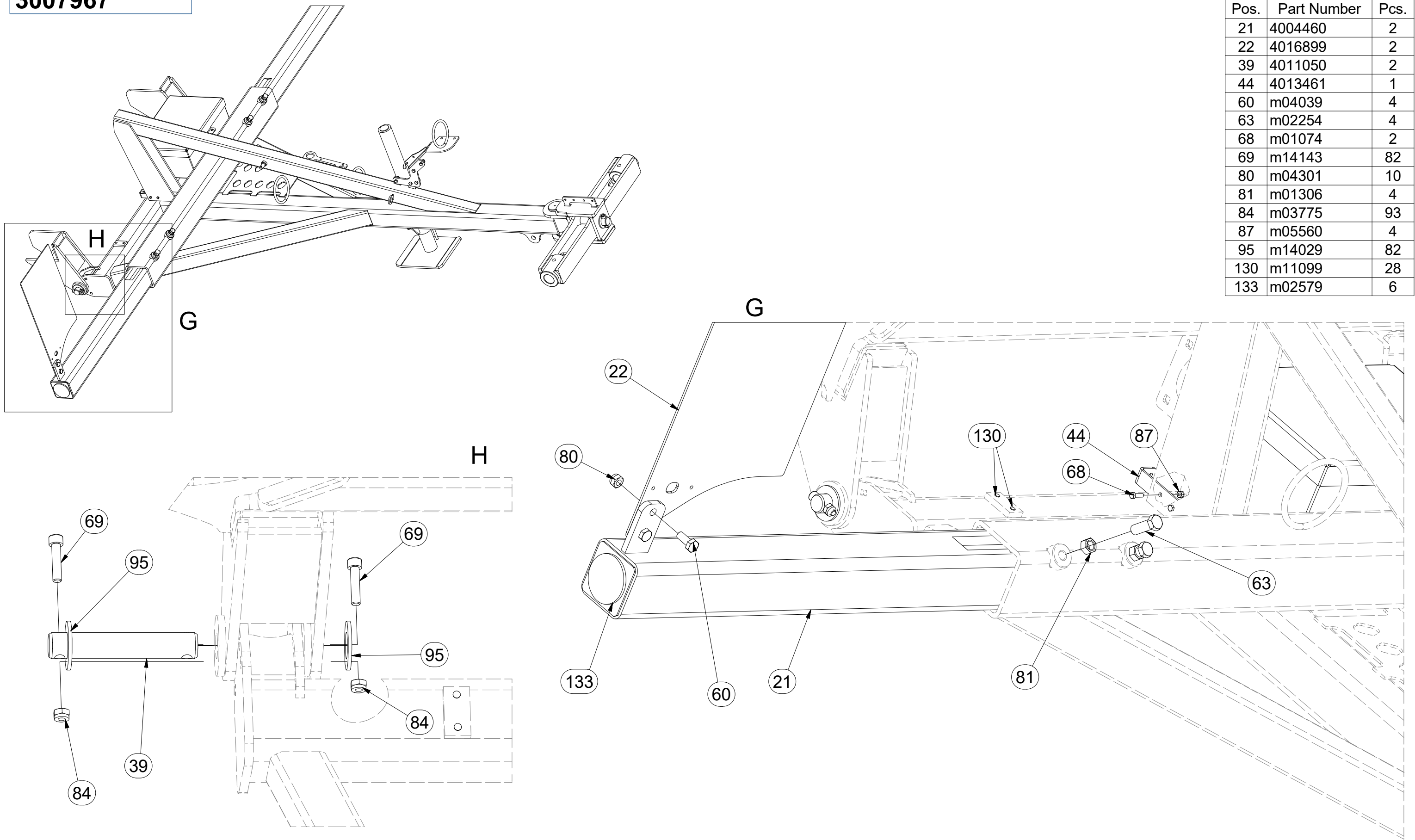

☉ POLOTOVAR STROJE

☉ MASCHINEN-HALBFABRIKAT

☉ MACHINE - SEMI-PRODUIT

☉ SEMIFINISHED MACHINE

☉ ПОЛУФАБРИКАТ МАШИНЫ

☉ PÓŁFABRYKAT MASZYN



3007967

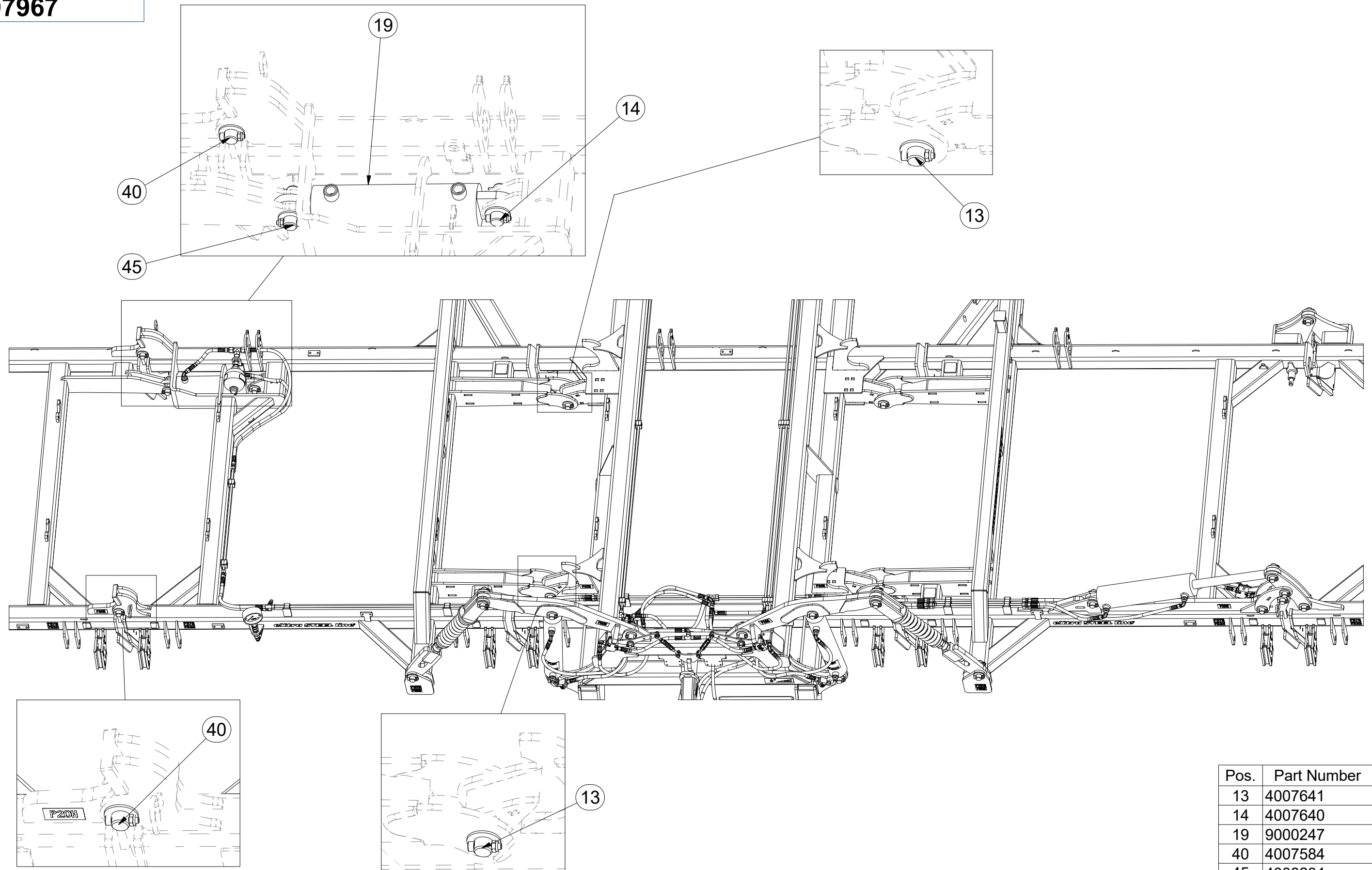

Pos.	Part Number	Pcs.
13	4007641	4
14	4007640	8
19	9000247	3
40	4007584	6
45	4008234	13

Ⓒ POLOTOVAR STROJE

Ⓓ MASCHINEN-HALBFABRIKAT

Ⓕ MACHINE - SEMI-PRODUIT

Ⓖ SEMIFINISHED MACHINE

Ⓡ ПОЛУФАБРИКАТ МАШИНЫ

Ⓢ РÓЉФАБРЫКАТ МАСЗЫНЫ



3007967

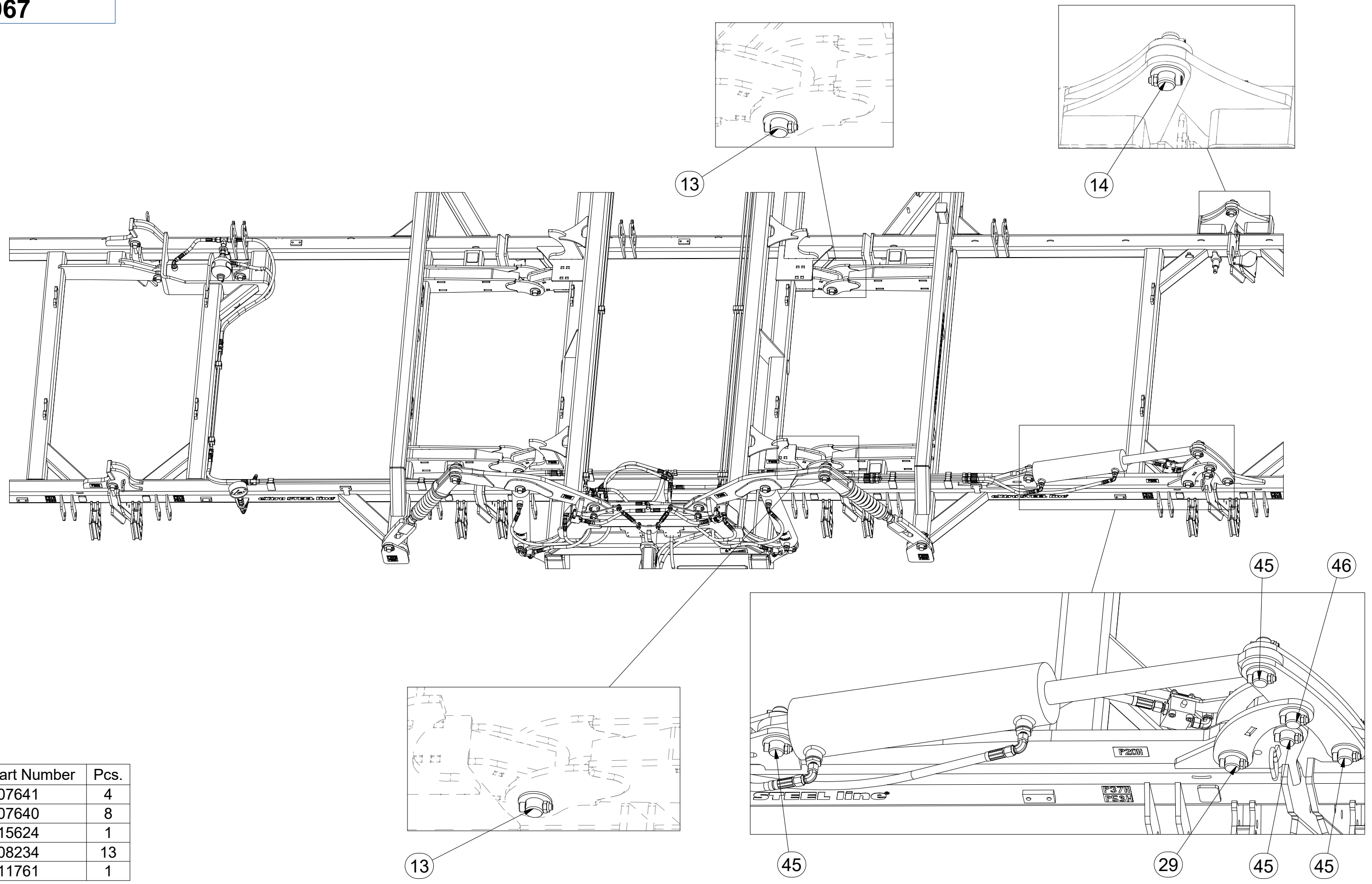

Pos.	Part Number	Pcs.
13	4007641	4
14	4007640	8
29	4015624	1
45	4008234	13
46	4011761	1

Ⓒ POLOTOVAR STROJE

Ⓓ MASCHINEN-HALBFABRIKAT

Ⓕ MACHINE - SEMI-PRODUIT

Ⓖ SEMIFINISHED MACHINE

Ⓡ ПОЛУФАБРИКАТ МАШИНЫ

Ⓢ РÓŁФАБРЫКАТ МАСЗЫНЫ



3007967

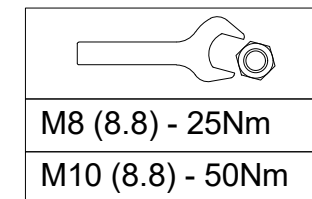
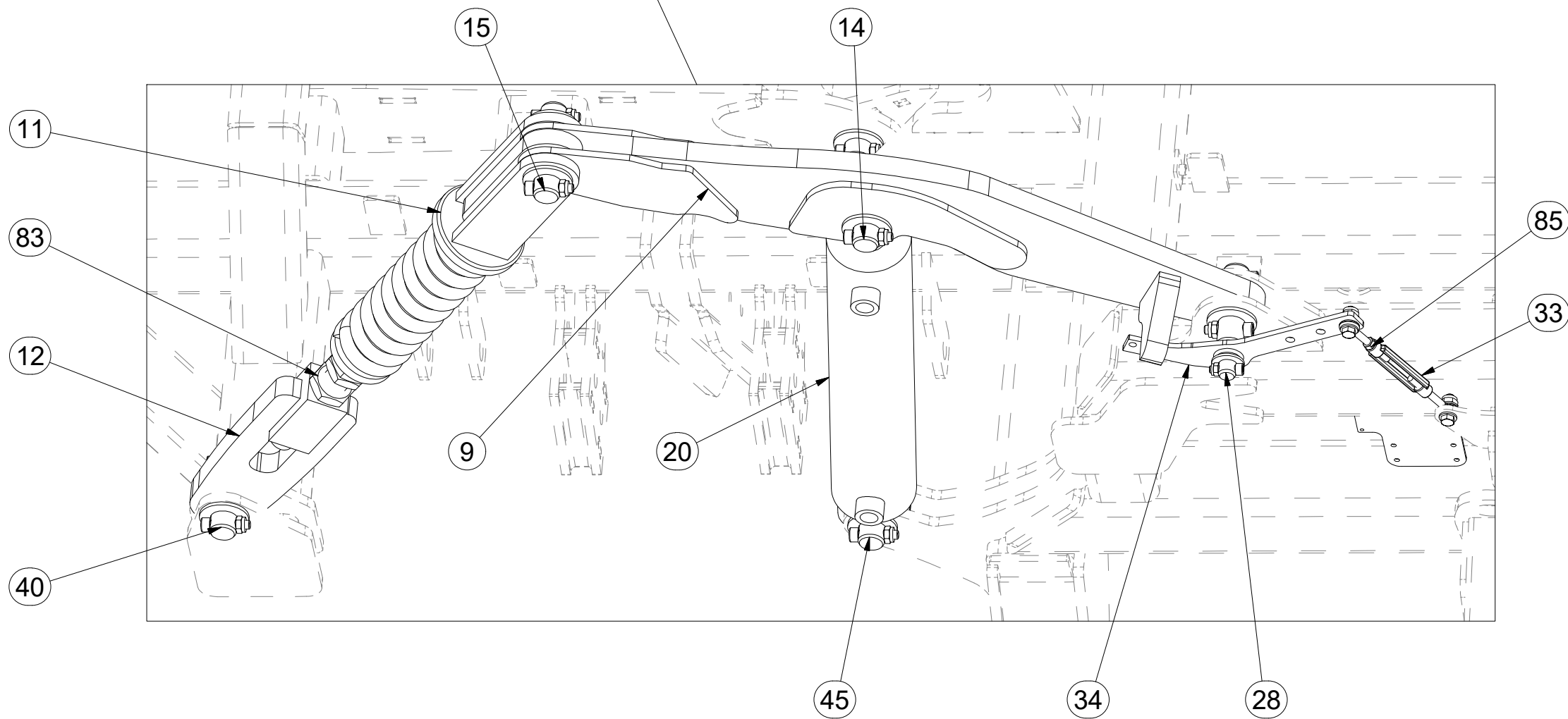
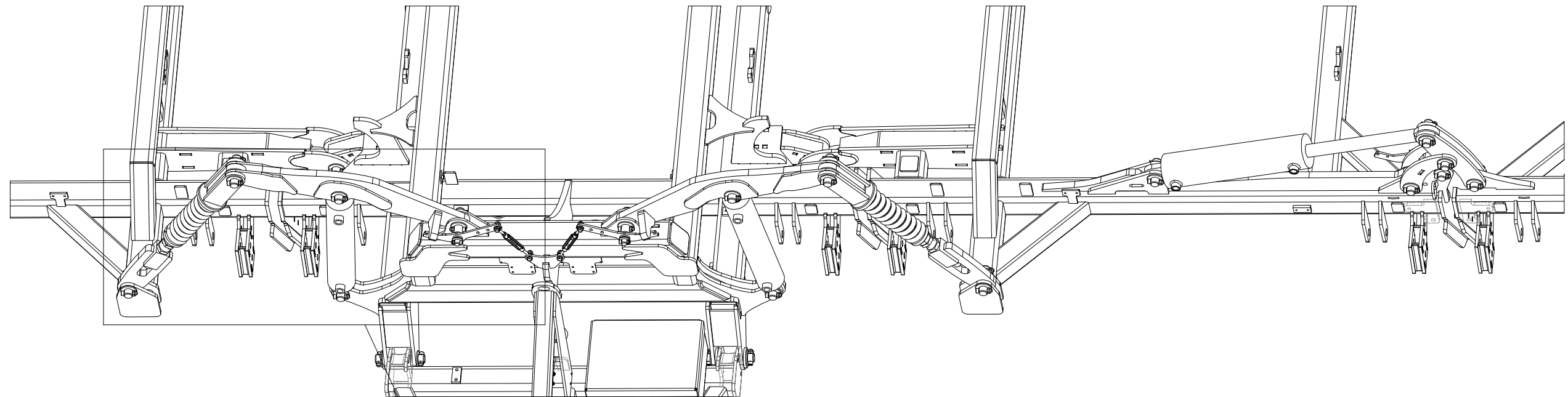

Pos.	Part Number	Pcs.
9	3005410	1
11	4005363	4
12	4005366	4
14	4007640	8
15	4014569	4
20	9000248	4
28	4015623	2
33	m09964	3
34	4010600	2
40	4007584	6
45	4008234	13
83	m04043	4
85	m01296	3

Ⓒ POLOTOVAR STROJE

Ⓓ MASCHINEN-HALBFABRIKAT

Ⓕ MACHINE - SEMI-PRODUIT

Ⓖ SEMIFINISHED MACHINE

Ⓡ ПОЛУФАБРИКАТ МАШИНЫ

Ⓟ PÓŁFABRYKAT MASZYN



3007967

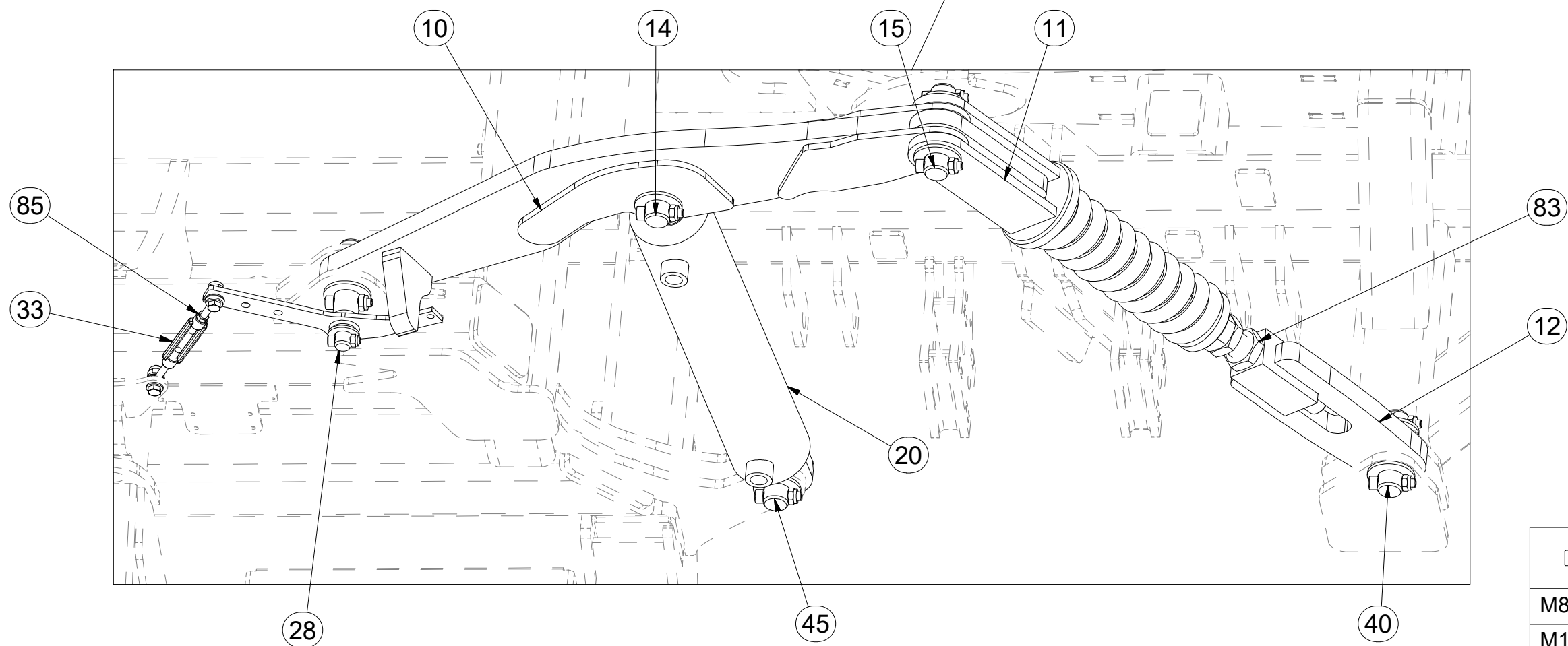
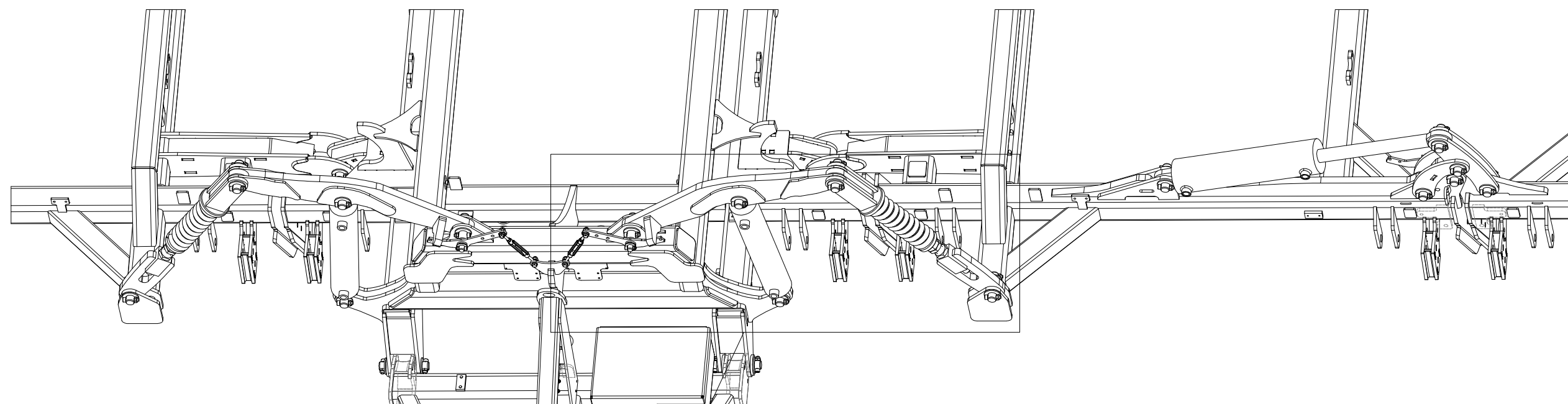

M8 (8.8) - 25Nm
M10 (8.8) - 50Nm

Pos.	Part Number	Pcs.
10	3005411	1
11	4005363	4
12	4005366	4
14	4007640	8
15	4014569	4
20	9000248	4
28	4015623	2
33	m09964	3
40	4007584	6
45	4008234	13
83	m04043	4
85	m01296	3

☉ POLOTOVAR STROJE

☉ MASCHINEN-HALBFABRIKAT

☉ MACHINE - SEMI-PRODUIT

☉ SEMIFINISHED MACHINE

☉ ПОЛУФАБРИКАТ МАШИНЫ

☉ PÓLFABRYKAT MASZYNY



3007967

Pos.	Part Number	Pcs.
14	4007640	8
15	4014569	4
28	4015623	2
33	m09964	3
34	4010600	2
40	4007584	6
45	4008234	13
62	m04612	6
69	m14143	82
70	m09870	3
84	m03775	93
86	m04503	18
91	m01209	12
95	m14029	82
96	m14030	3

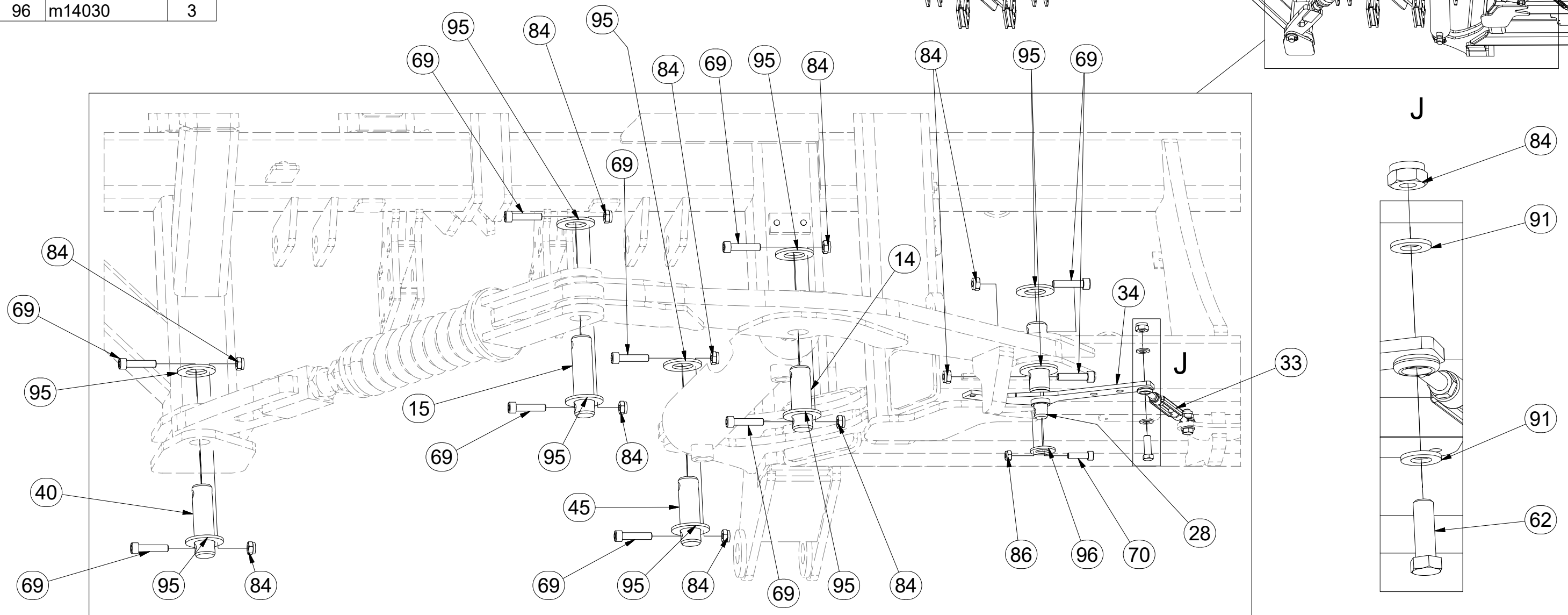
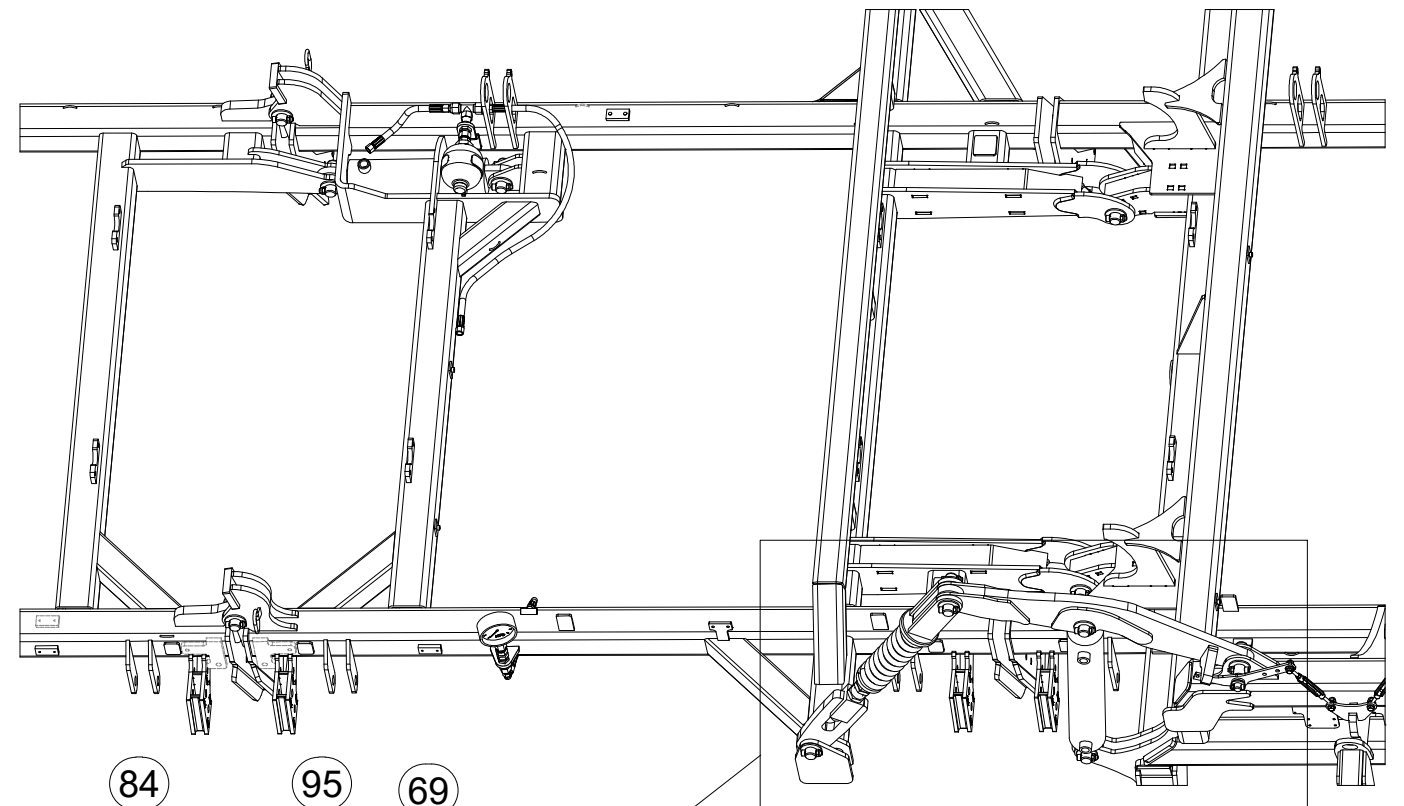

Ⓒ POLOTOVAR STROJE

Ⓓ MASCHINEN-HALBFABRIKAT

Ⓕ MACHINE - SEMI-PRODUIT

Ⓖ SEMIFINISHED MACHINE

Ⓡ ПОЛУФАБРИКАТ МАШИНЫ

Ⓢ РÓЉФАБРЫКАТ МАСЗЫНЫ



3007967

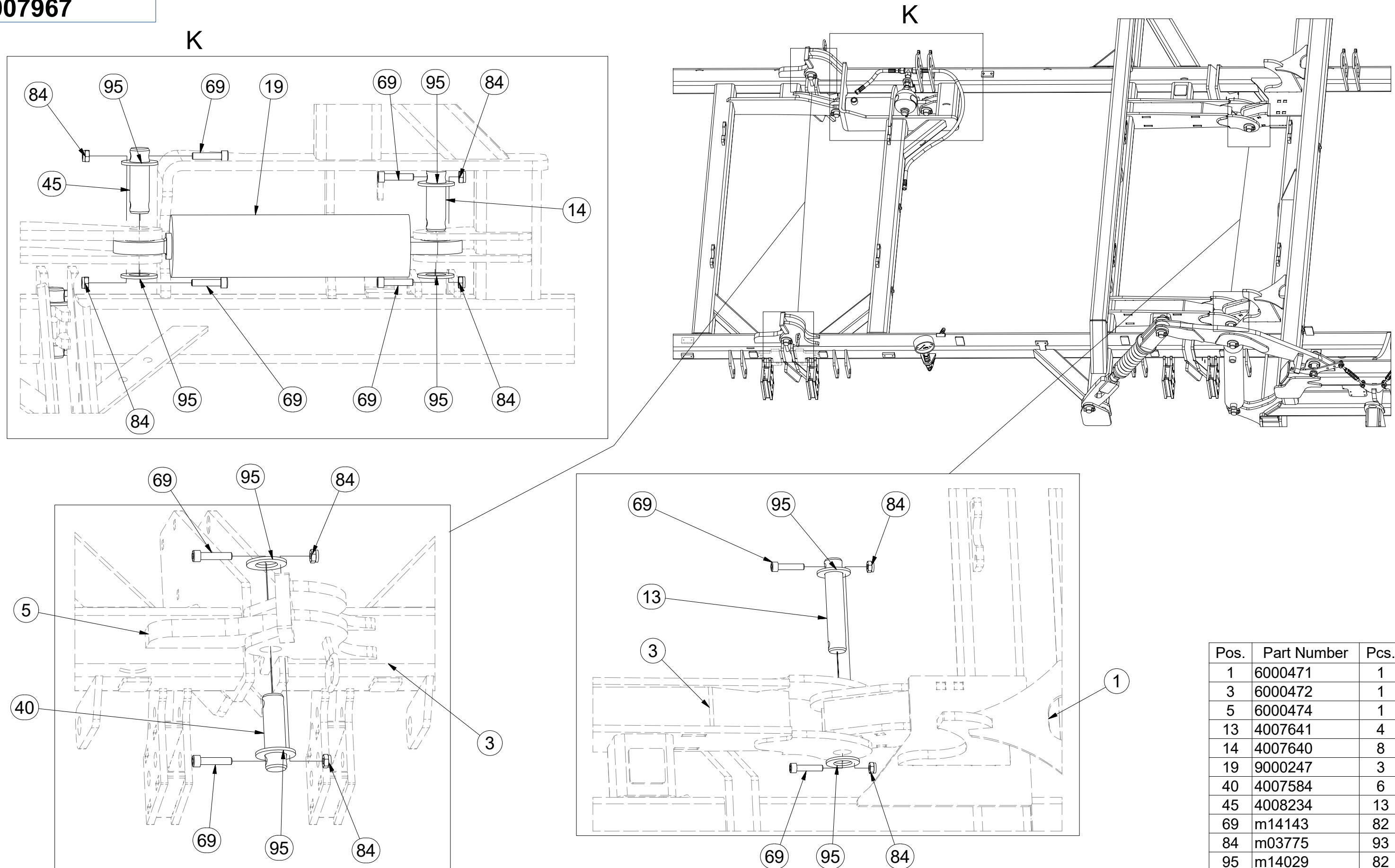

Pos.	Part Number	Pcs.
1	6000471	1
3	6000472	1
5	6000474	1
13	4007641	4
14	4007640	8
19	9000247	3
40	4007584	6
45	4008234	13
69	m14143	82
84	m03775	93
95	m14029	82

☉ POLOTOVAR STROJE

☉ MASCHINEN-HALBFABRIKAT

☉ MACHINE - SEMI-PRODUIT

☉ SEMIFINISHED MACHINE

☉ ПОЛУФАБРИКАТ МАШИНЫ

☉ PÓLFABRYKAT MASZYNY



3007967

Pos.	Part Number	Pcs.
1	6000471	1
2	6000473	1
13	4007641	4
14	4007640	8
15	4014569	4
28	4015623	2
33	m09964	3
40	4007584	6
45	4008234	13
62	m04612	6
69	m14143	82
70	m09870	3
84	m03775	93
86	m04503	18
91	m01209	12
95	m14029	82
96	m14030	3

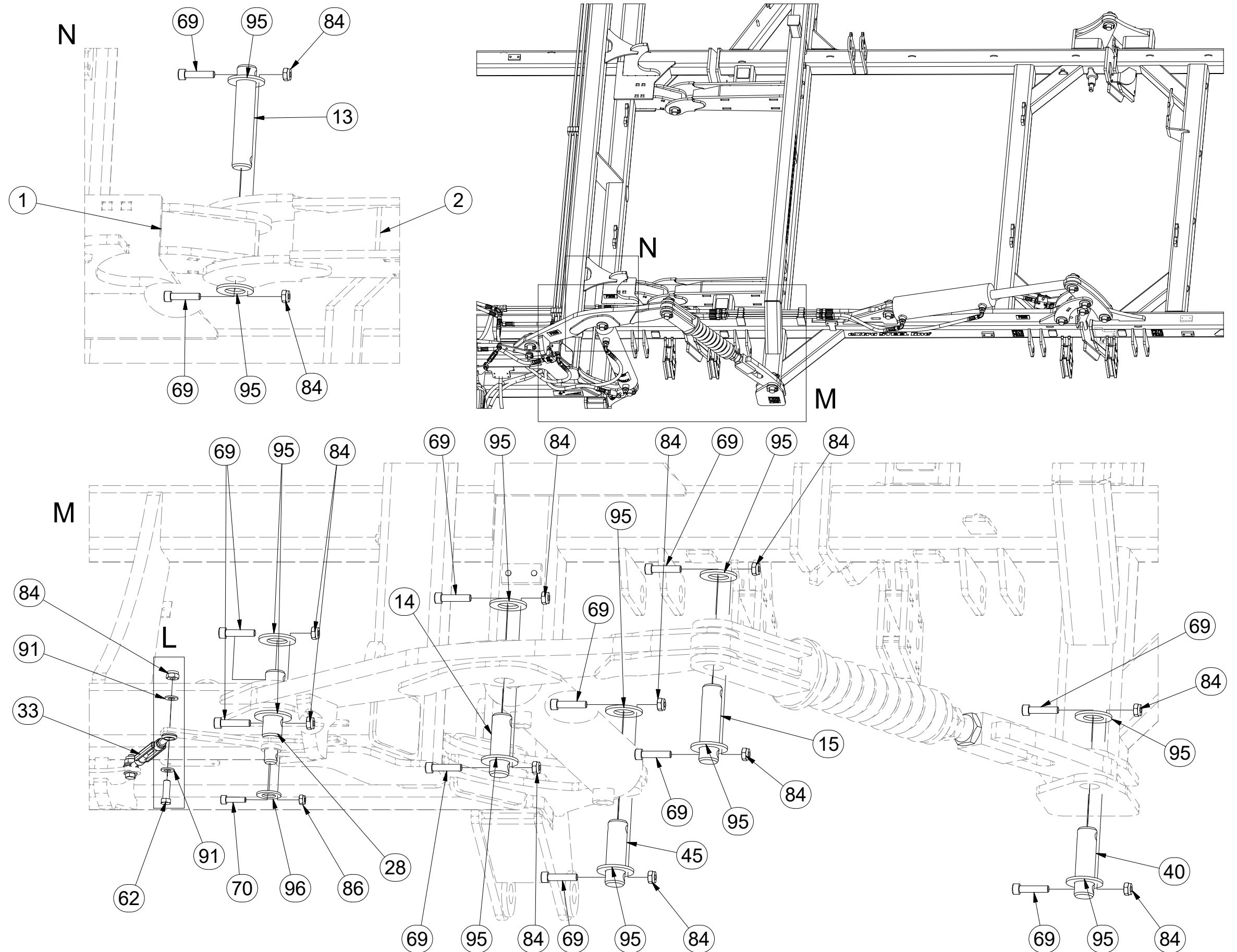

Ⓒ POLOTOVAR STROJE

Ⓓ MASCHINEN-HALBFABRIKAT

Ⓕ MACHINE - SEMI-PRODUIT

Ⓖ SEMIFINISHED MACHINE

Ⓡ ПОЛУФАБРИКАТ МАШИНЫ

Ⓟ PÓŁFABRYKAT MASZYN



3007967

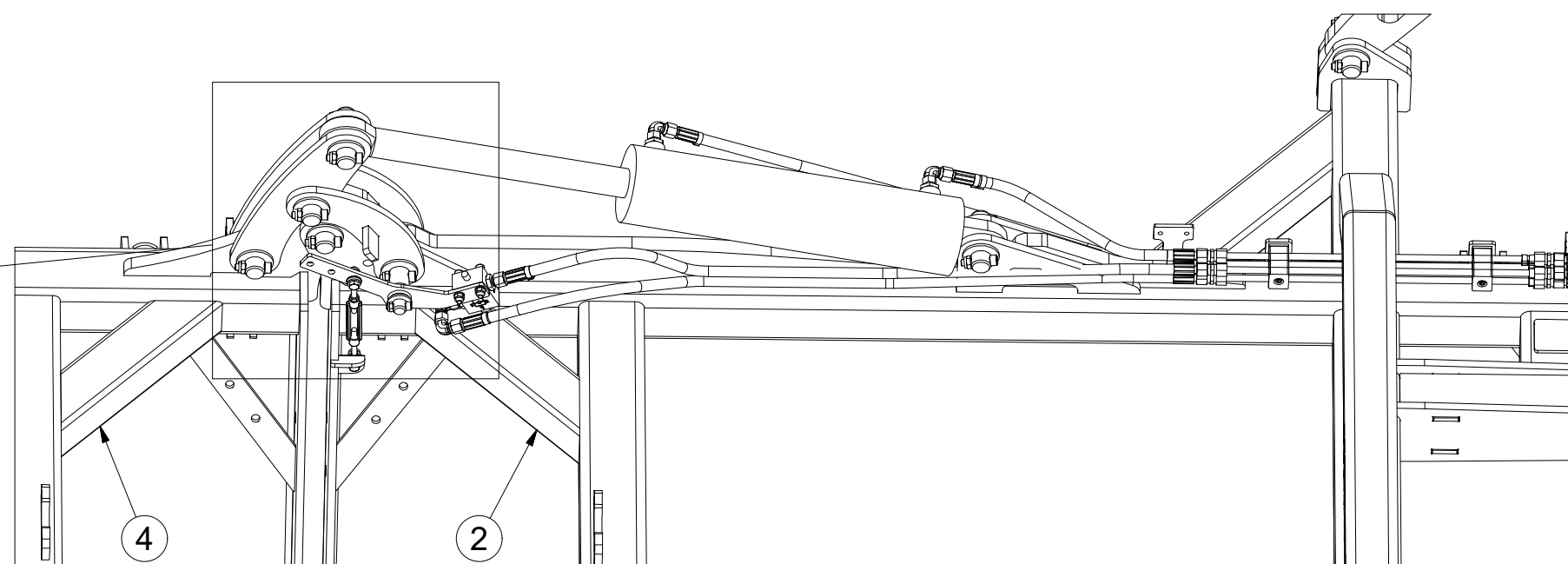
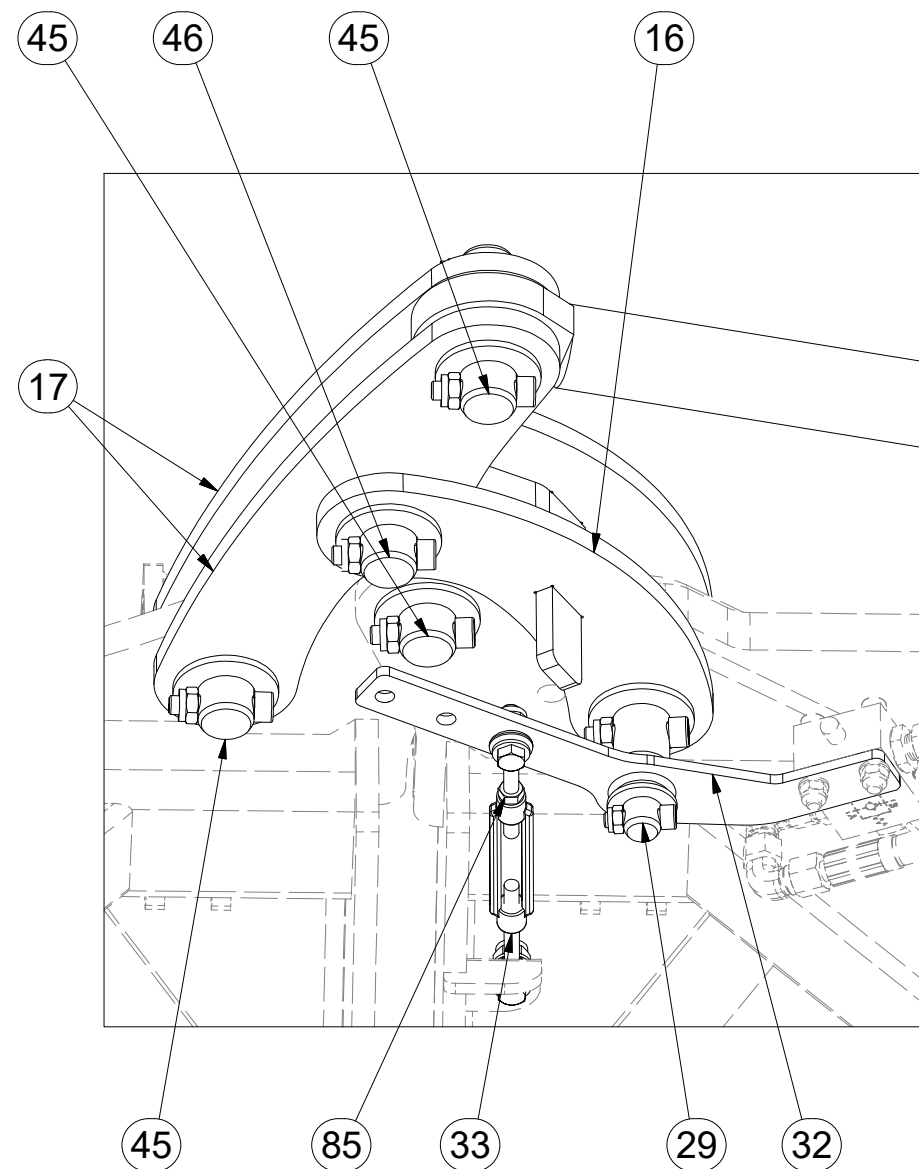

Pos.	Part Number	Pcs.
2	6000473	1
4	6000475	1
16	3003057	1
17	4010308	2
29	4015624	1
32	4005414	1
33	m09964	3
45	4008234	13
46	4011761	1
85	m01296	3

M8 (8.8) - 25Nm
M10 (8.8) - 50Nm

☉ POLOTOVAR STROJE

☉ MASCHINEN-HALBFABRIKAT

☉ MACHINE - SEMI-PRODUIT

☉ SEMIFINISHED MACHINE

☉ ПОЛУФАБРИКАТ МАШИНЫ

☉ PÓLFABRYKAT MASZYNY



3007967

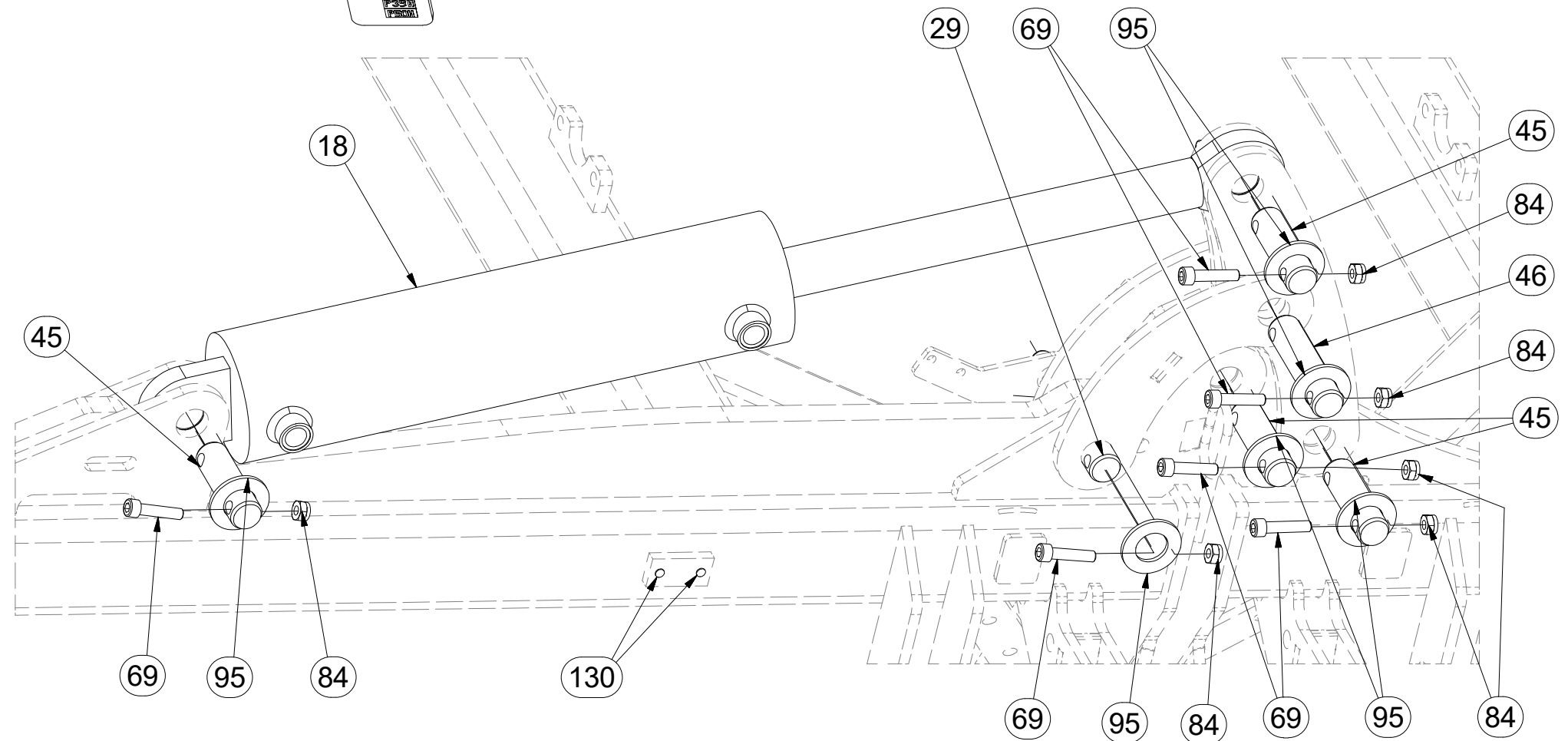
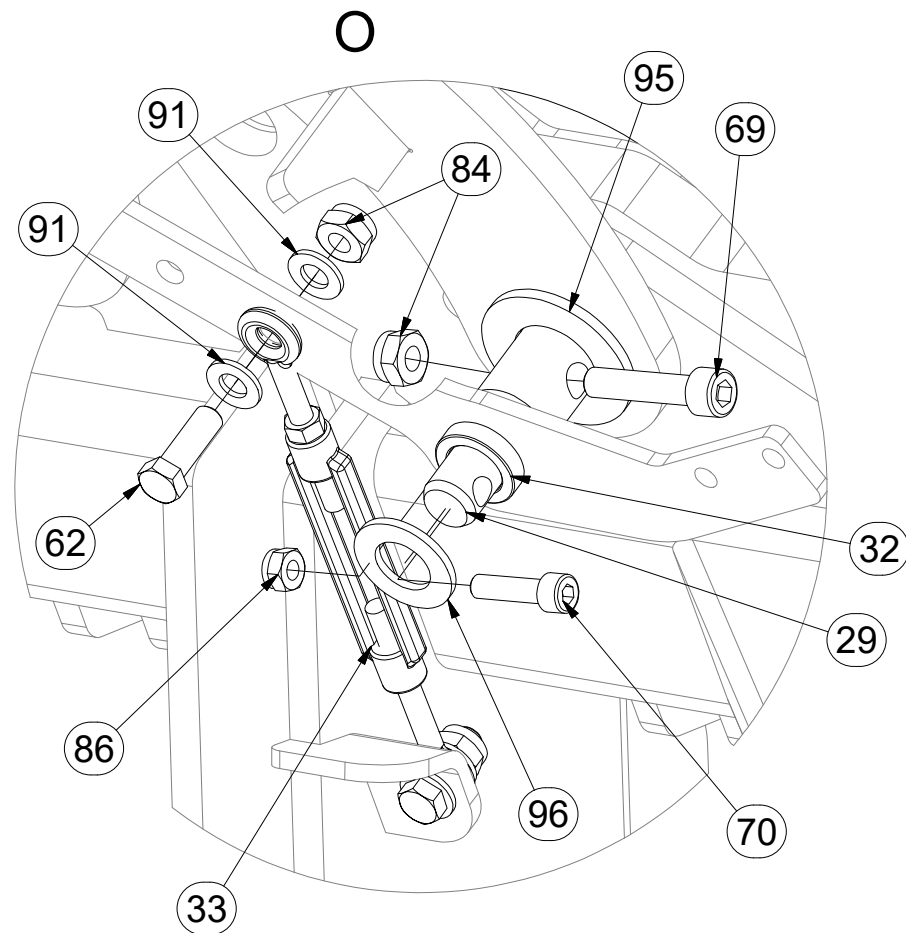
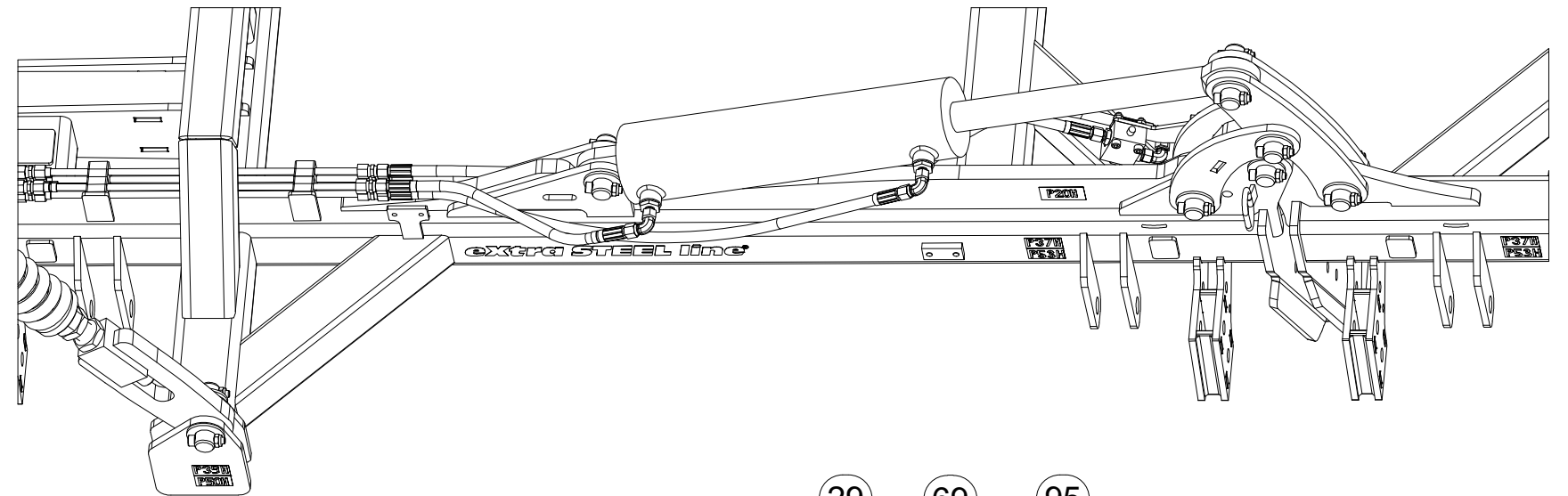
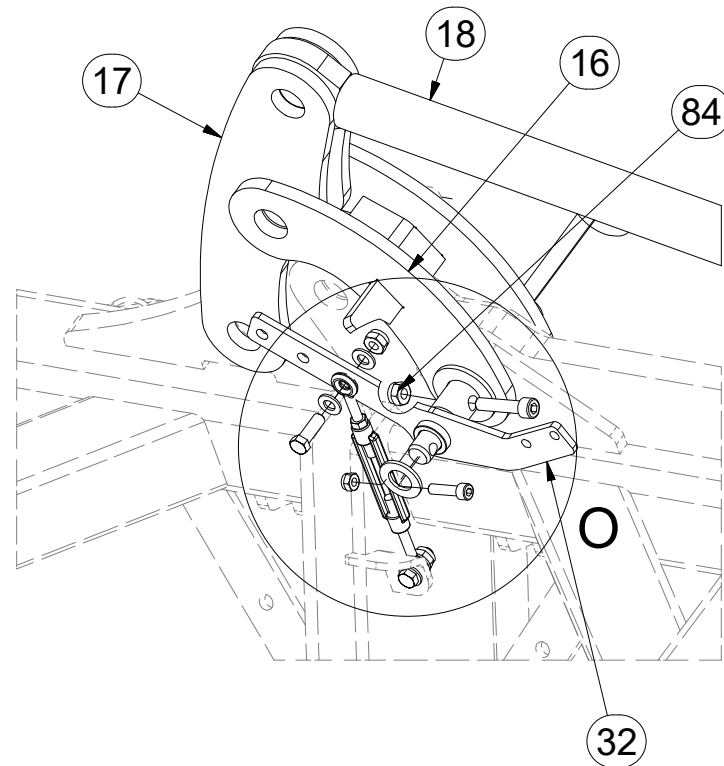

M8 (8.8) - 25Nm
M10 (8.8) - 50Nm

Pos.	Part Number	Pcs.	Pos.	Part Number	Pcs.	Pos.	Part Number	Pcs.
16	3003057	1	45	4008234	13	85	m01296	3
17	4010308	2	46	4011761	1	86	m04503	18
18	9002967	1	62	m04612	6	91	m01209	12
29	4015624	1	69	m14143	82	95	m14029	82
32	4005414	1	70	m09870	3	96	m14030	3
33	m09964	3	84	m03775	93	130	m11099	28

☉ POLOTOVAR STROJE

☉ MASCHINEN-HALBFABRIKAT

☉ MACHINE - SEMI-PRODUIT

☉ SEMIFINISHED MACHINE

☉ ПОЛУФАБРИКАТ МАШИНЫ

☉ PÓLFABRYKAT MASZYN



3007967

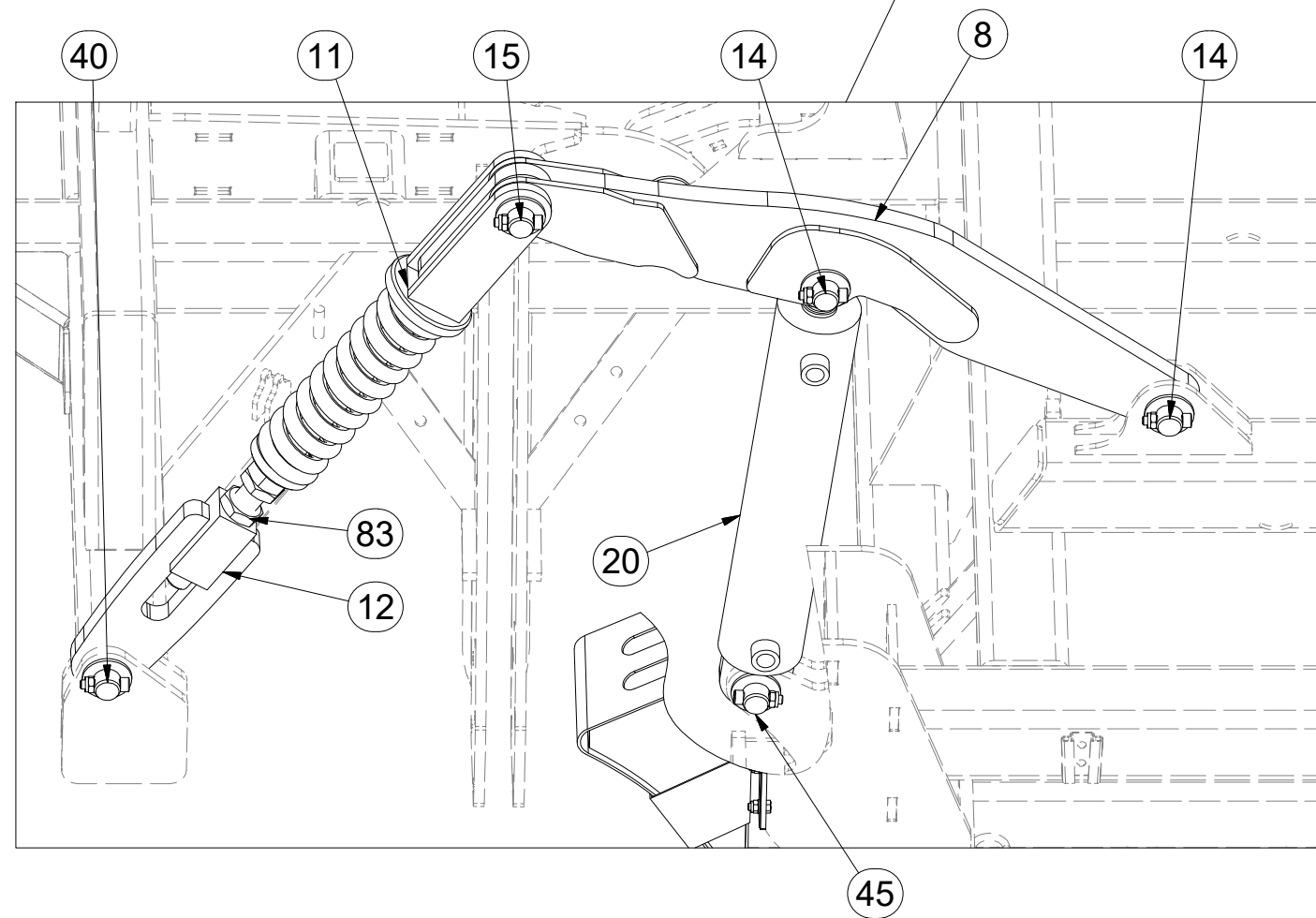
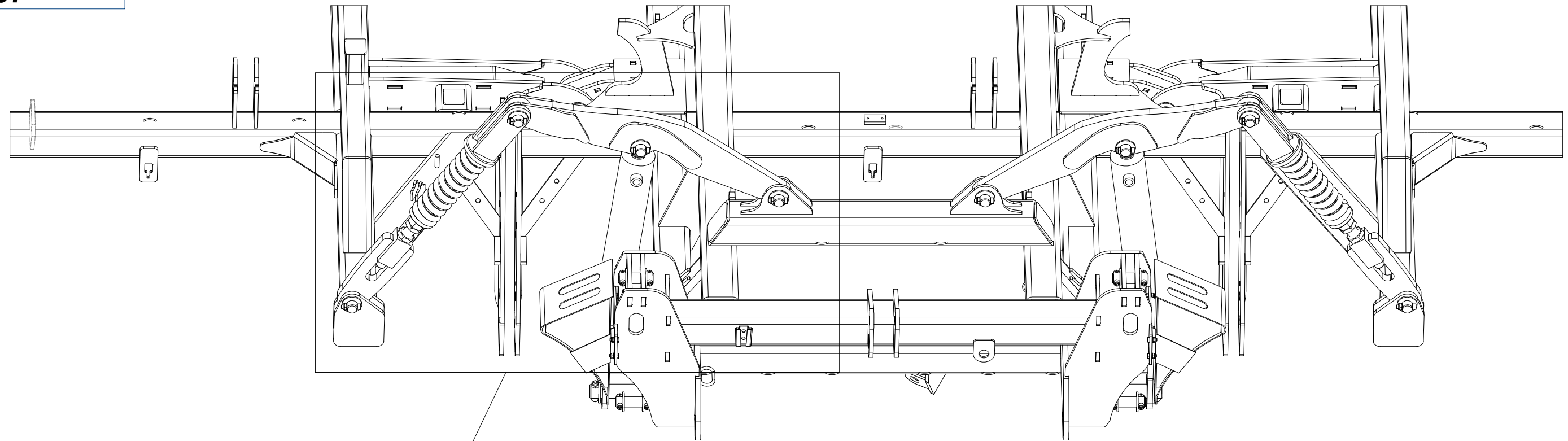

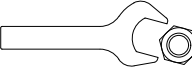
M8 (8.8) - 25Nm
M10 (8.8) - 50Nm

Pos.	Part Number	Pcs.
8	3002837	2
11	4005363	4
12	4005366	4
14	4007640	8
15	4014569	4
20	9000248	4
40	4007584	6
45	4008234	13
83	m04043	4

☉ POLOTOVAR STROJE

☉ MASCHINEN-HALBFABRIKAT

☉ MACHINE - SEMI-PRODUIT

☉ SEMIFINISHED MACHINE

☉ ПОЛУФАБРИКАТ МАШИНЫ

☉ PÓLFABRYKAT MASZYNY



3007967

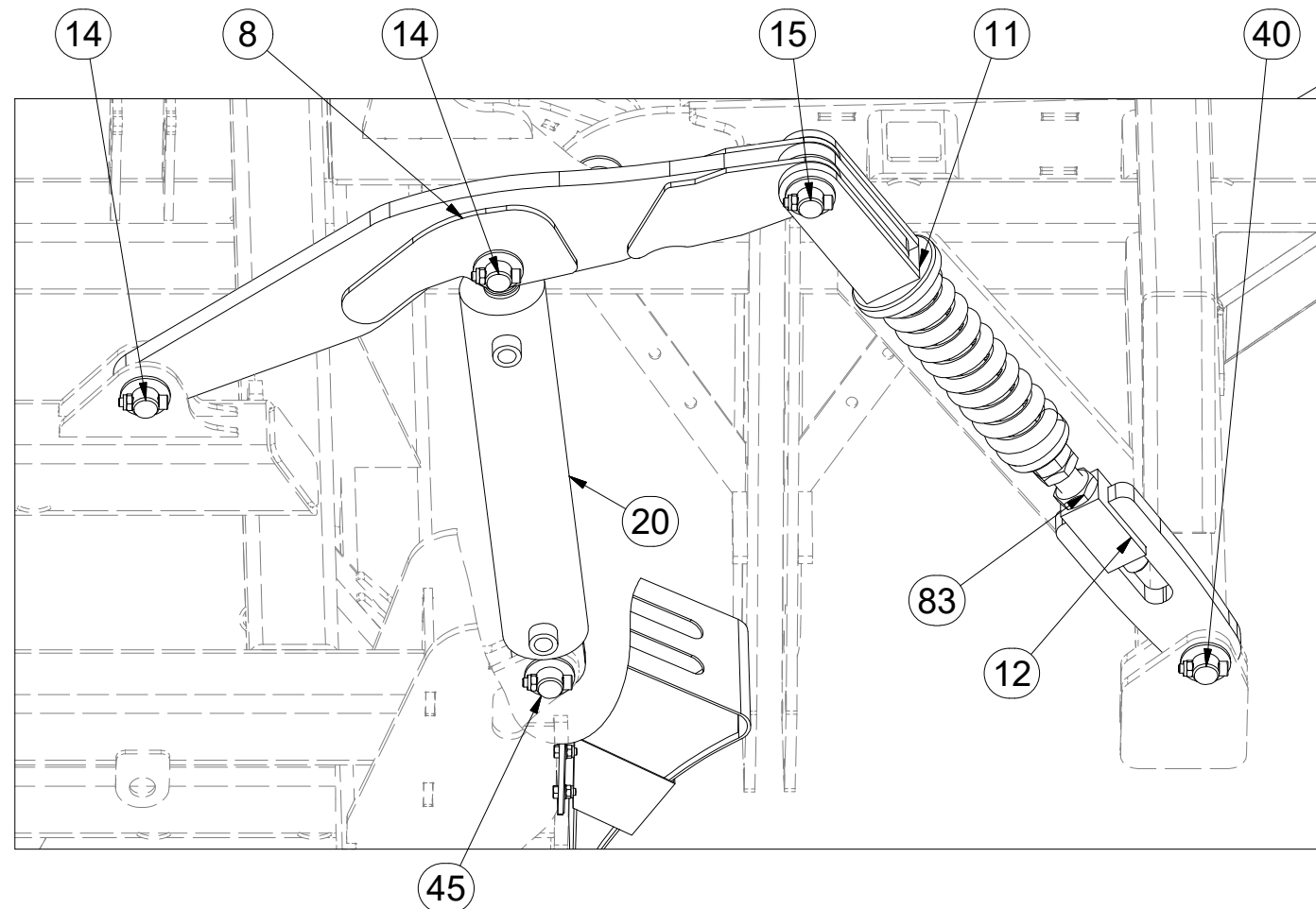
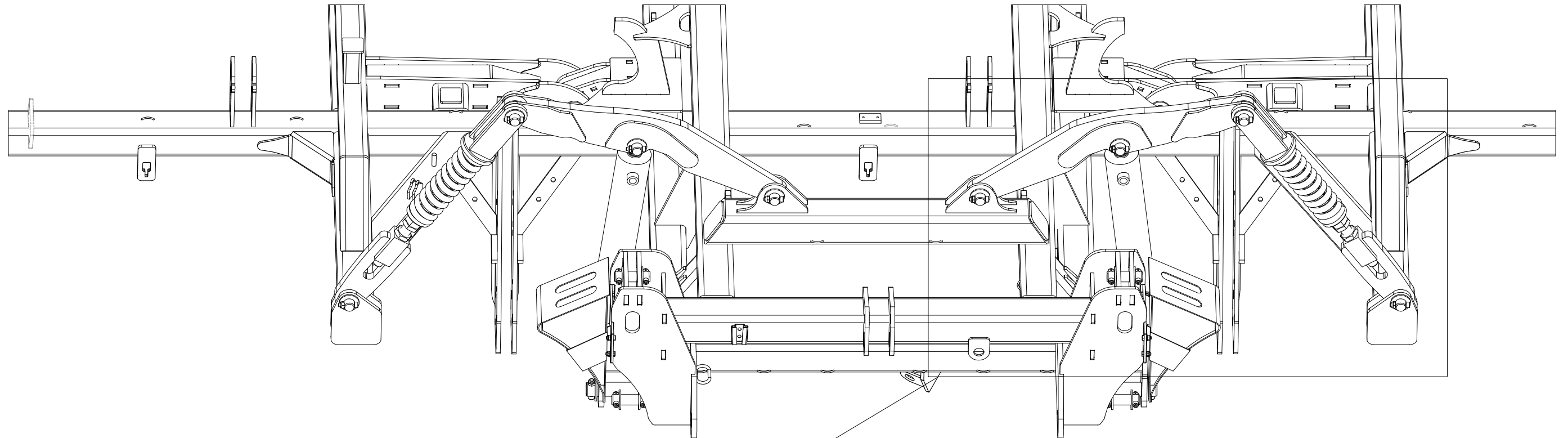

Pos.	Part Number	Pcs.
8	3002837	2
11	4005363	4
12	4005366	4
14	4007640	8
15	4014569	4
20	9000248	4
40	4007584	6
45	4008234	13
83	m04043	4

M8 (8.8) - 25Nm
M10 (8.8) - 50Nm

☉ POLOTOVAR STROJE

☉ MASCHINEN-HALBFABRIKAT

☉ MACHINE - SEMI-PRODUIT

☉ SEMIFINISHED MACHINE

☉ ПОЛУФАБРИКАТ МАШИНЫ

☉ PÓŁFABRYKAT MASZYN



3007967

Pos.	Part Number	Pcs.
14	4007640	8
15	4014569	4
23	4010875	2
40	4007584	6
45	4008234	13
69	m14143	82
84	m03775	93
94	4013139	6
95	m14029	82

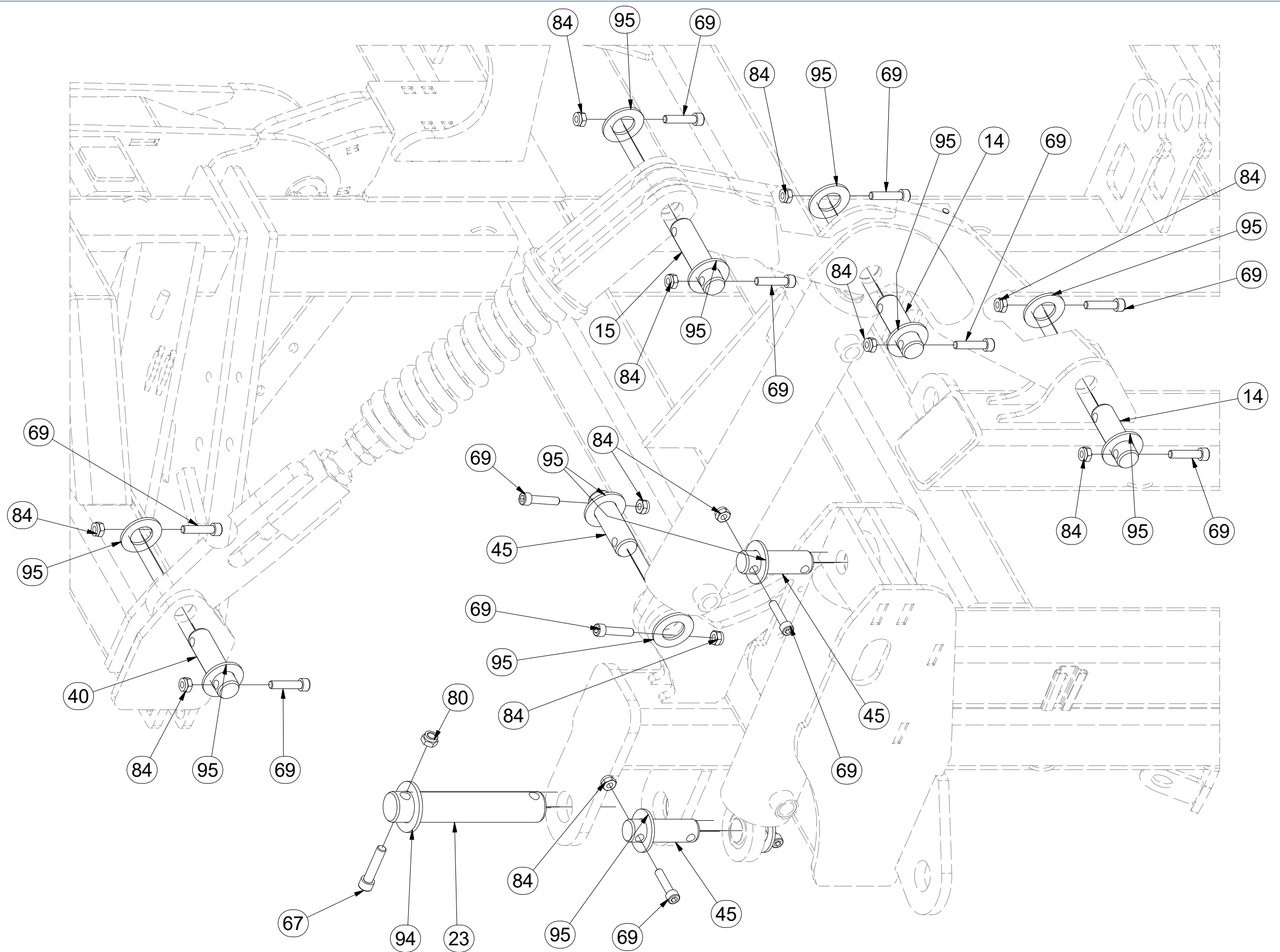

☉ HYDRAULIKA STROJE

☉ HYDRAULIK DER MASCHINE

☉ HYDRAULIQUE DE LA MACHINE

☉ MACHINE HYDRAULICS

☉ ГИДРАВЛИКА МАШИНЫ

☉ HYDRAULIKA MASZYNY



m15720

Pos.	Part Number	Pcs.
6	m10056	2
11	m03952	3
15	m04827	6
16	m09628	2
28	m04623	4
33	m09934	16
39	m03213	2
40	m10493	4
45	m05488	19
48	m11289	18
49	m01637	15
101	m04021	5



M6 (8.8) - 10Nm
 HYDRAULIC COMPONENTS:
 M16 x 1,5 - 60Nm
 M22 x 1,5 - 140Nm
 G 3/8 - 95 Nm

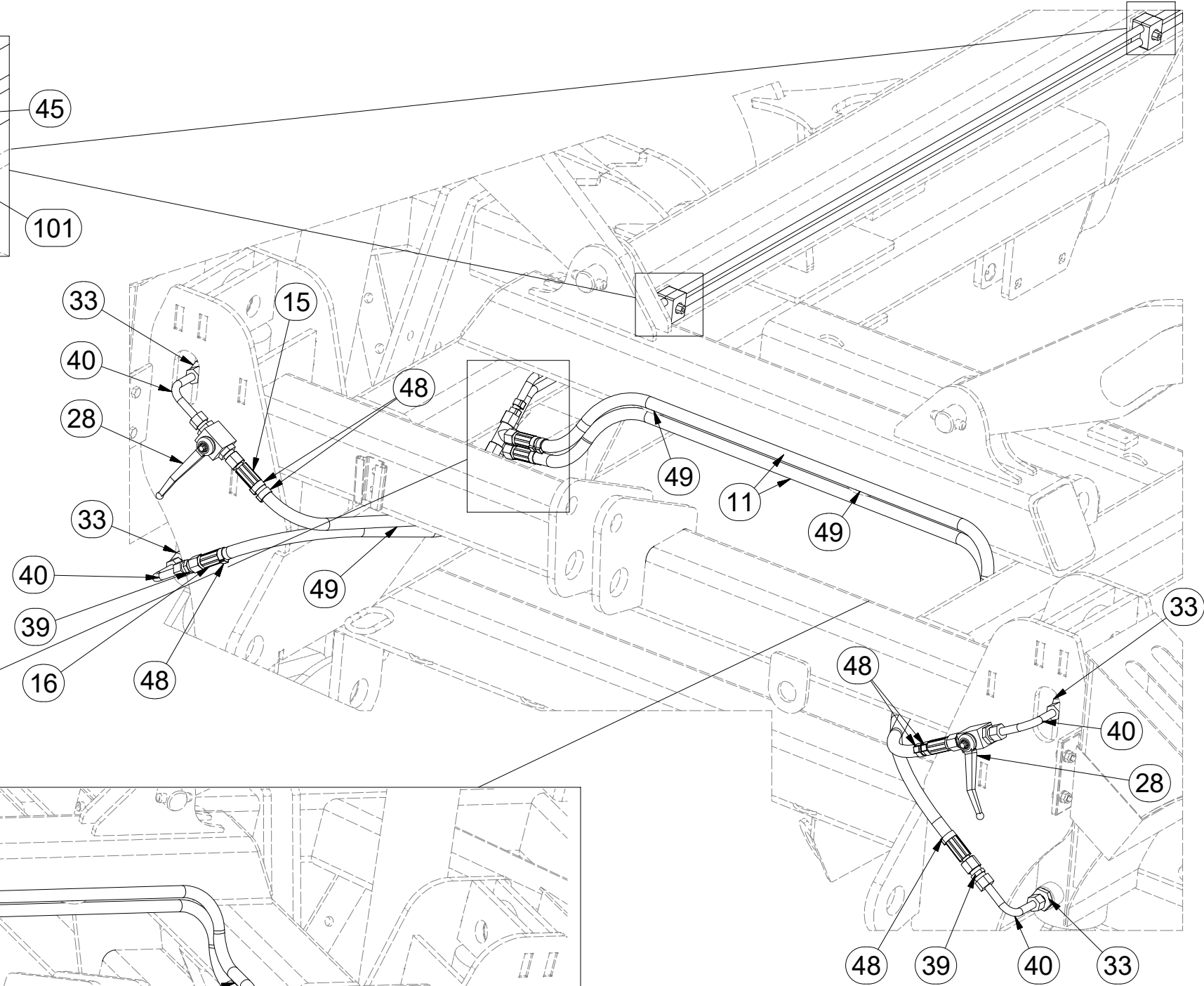
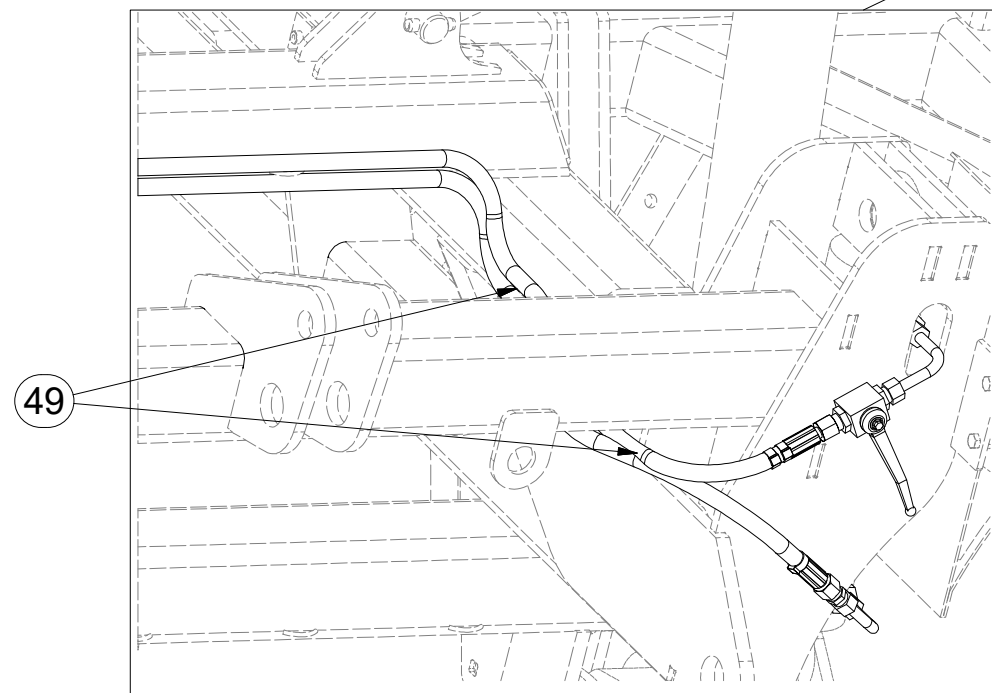
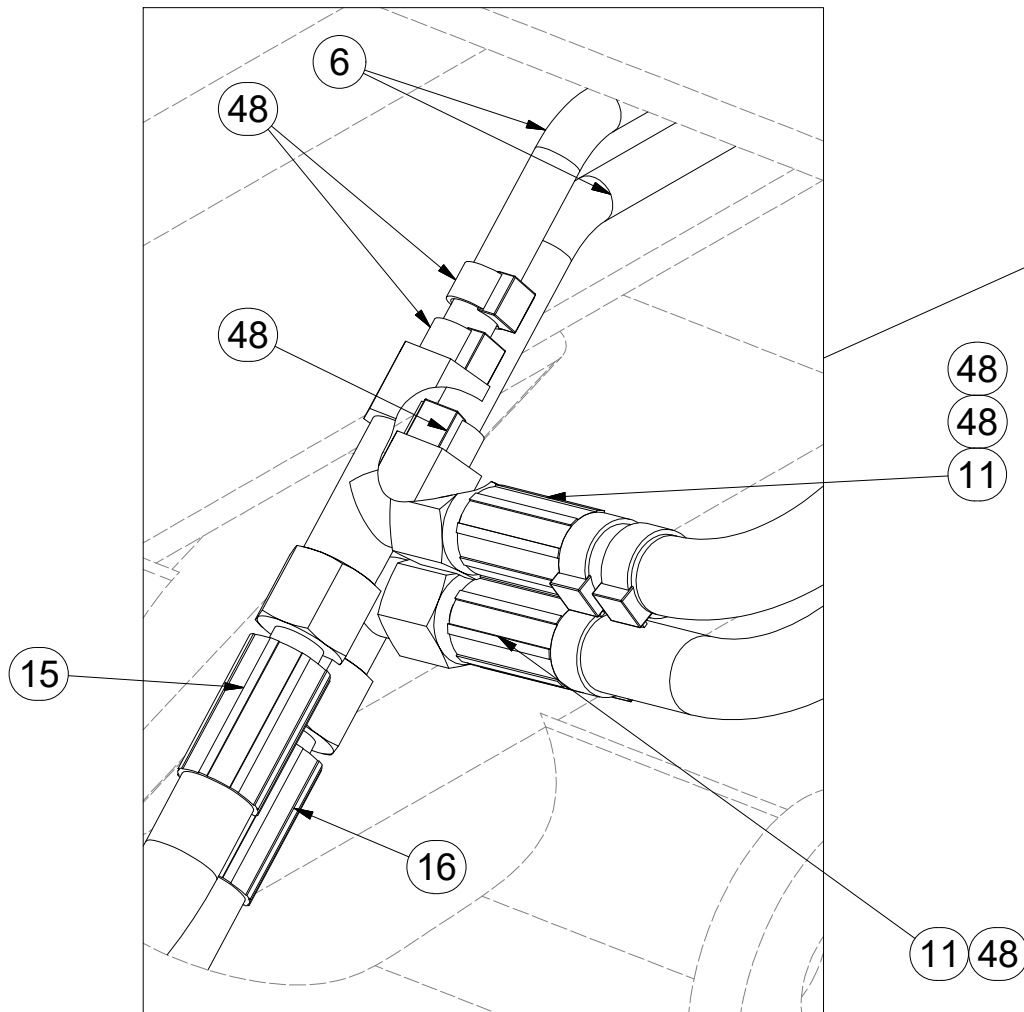
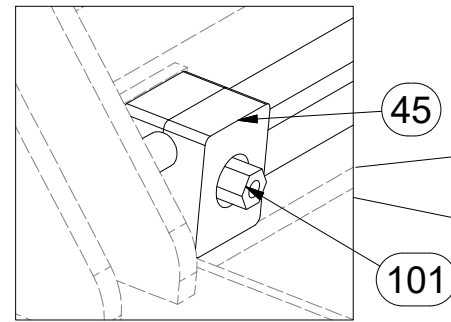

ⒸZ HYDRAULIKA STROJE

Ⓓ HYDRAULIK DER MASCHINE

Ⓕ HYDRAULIQUE DE LA MACHINE

ⒼB MACHINE HYDRAULICS

Ⓔ RU ГИДРАВЛИКА МАШИНЫ

Ⓗ PL HYDRAULIKA MASZYN



m11546

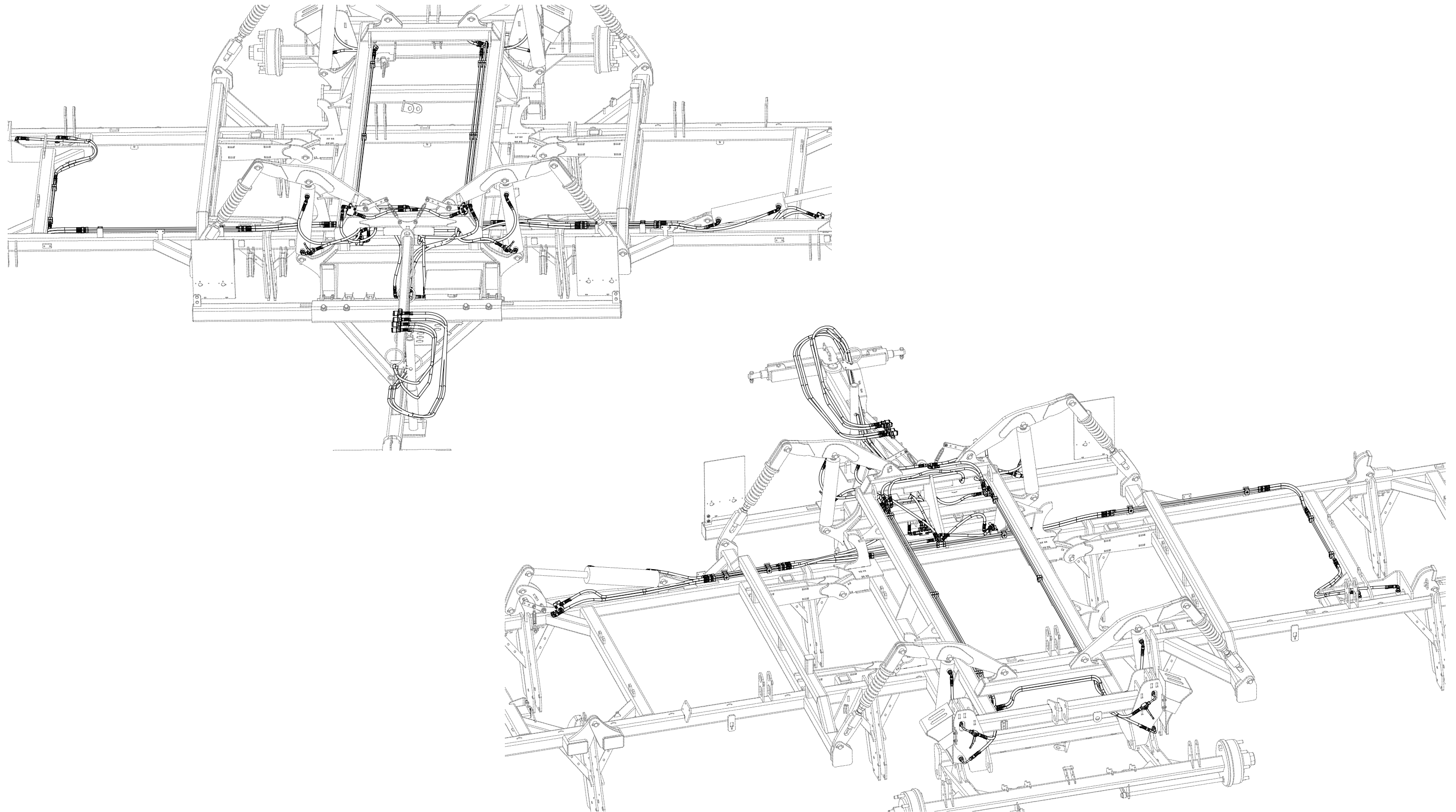

m11546

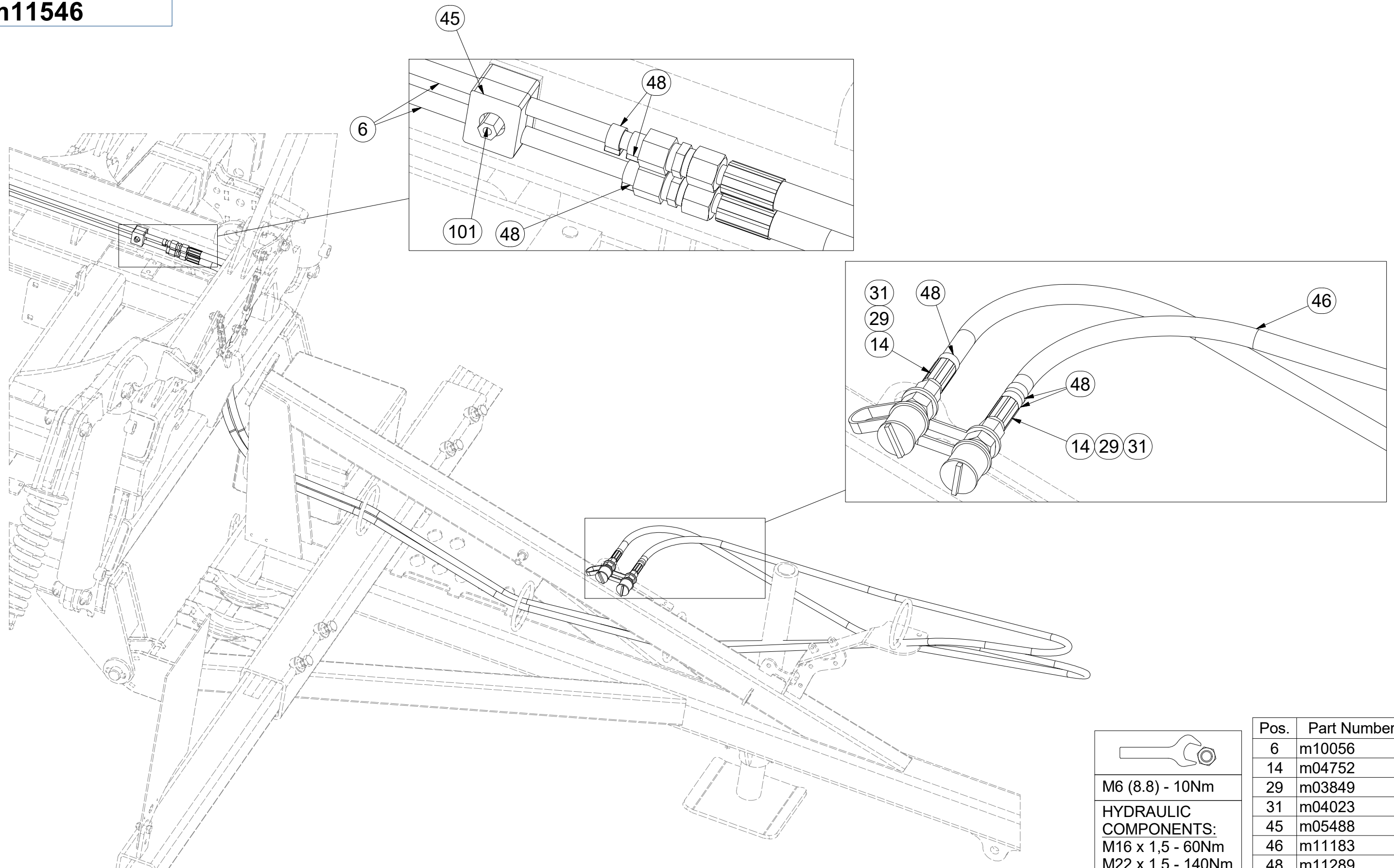

M6 (8.8) - 10Nm
HYDRAULIC COMPONENTS:
M16 x 1,5 - 60Nm
M22 x 1,5 - 140Nm
G 3/8 - 95 Nm

Pos.	Part Number	Pcs.
6	m10056	2
14	m04752	2
29	m03849	4
31	m04023	2
45	m05488	19
46	m11183	2
48	m11289	18
101	m04021	5

☉ HYDRAULIKA STROJE

☉ HYDRAULIK DER MASCHINE

☉ HYDRAULIQUE DE LA MACHINE

☉ MACHINE HYDRAULICS

☉ ГИДРАВЛИКА МАШИНЫ

☉ HYDRAULIKA MASZYNY



m11546

Pos.	Part Number	Pcs.
6	m10056	2
11	m03952	3
15	m04827	6
16	m09628	2
28	m04623	4
33	m09934	16
39	m03213	2
40	m10493	4
45	m05488	19
48	m11289	18
49	m01637	15
101	m04021	5



M6 (8.8) - 10Nm
 HYDRAULIC COMPONENTS:
 M16 x 1,5 - 60Nm
 M22 x 1,5 - 140Nm
 G 3/8 - 95 Nm

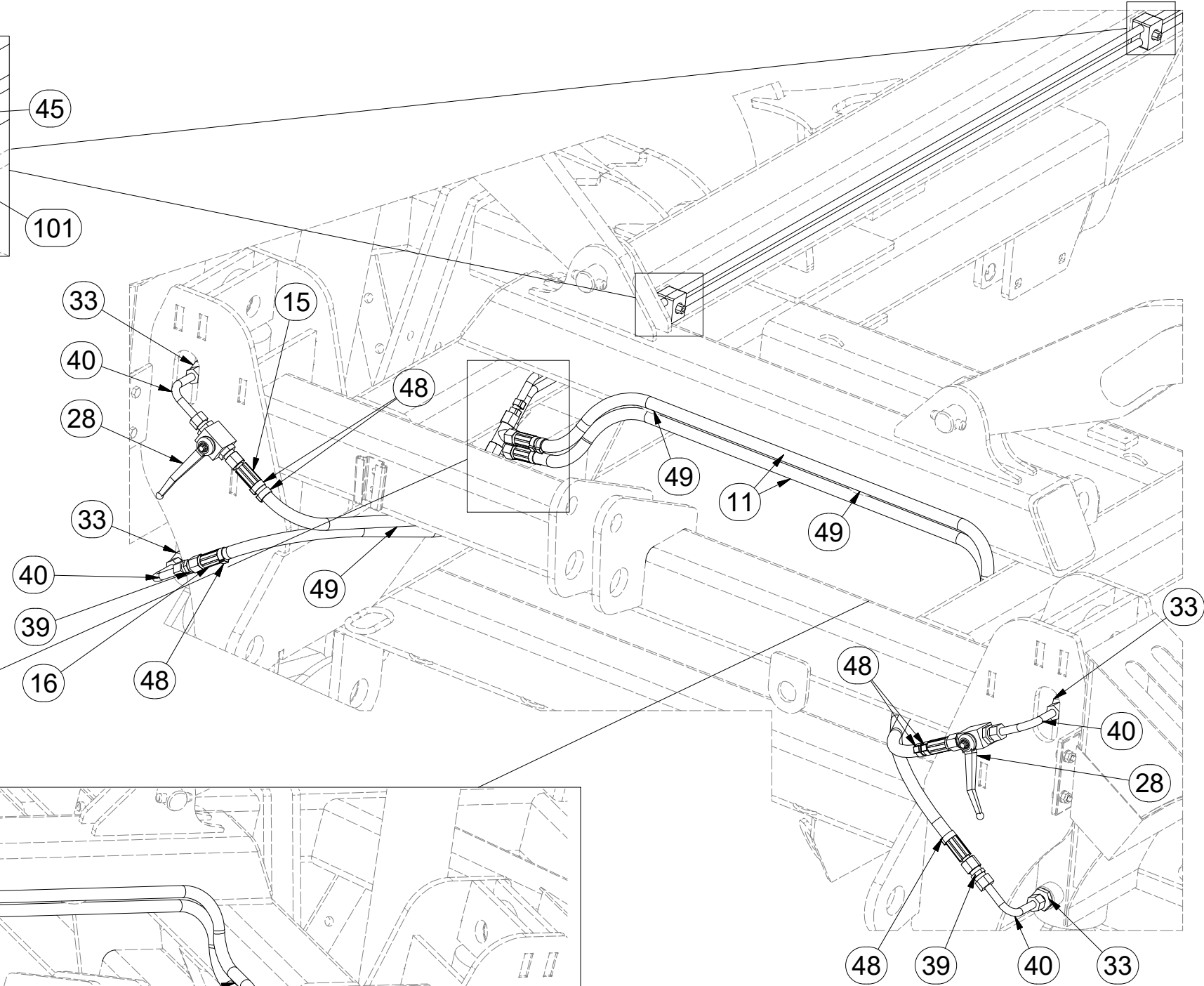
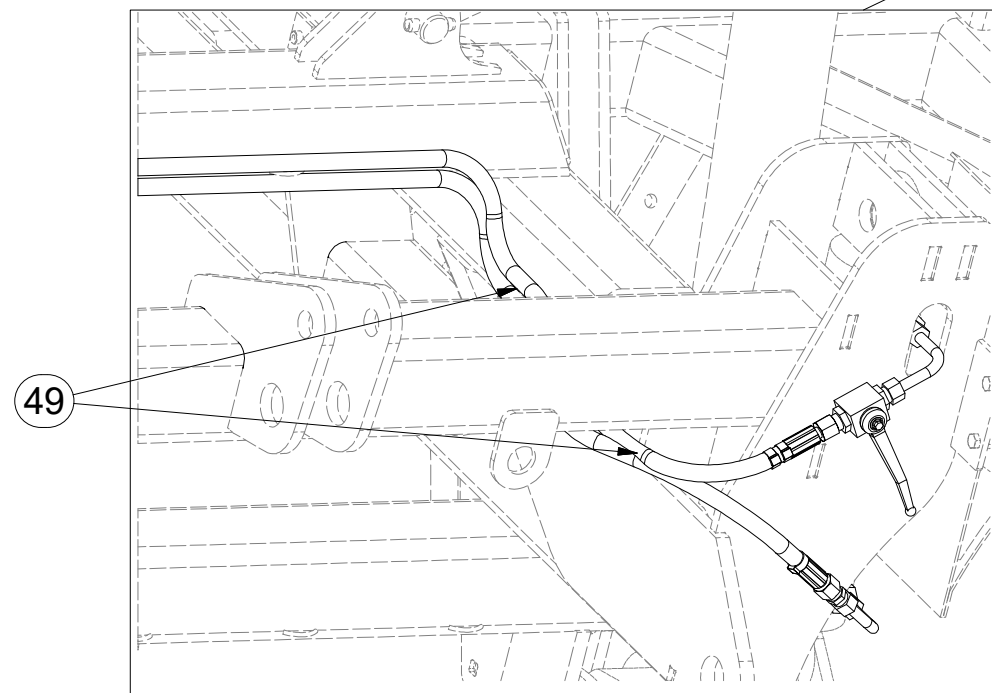
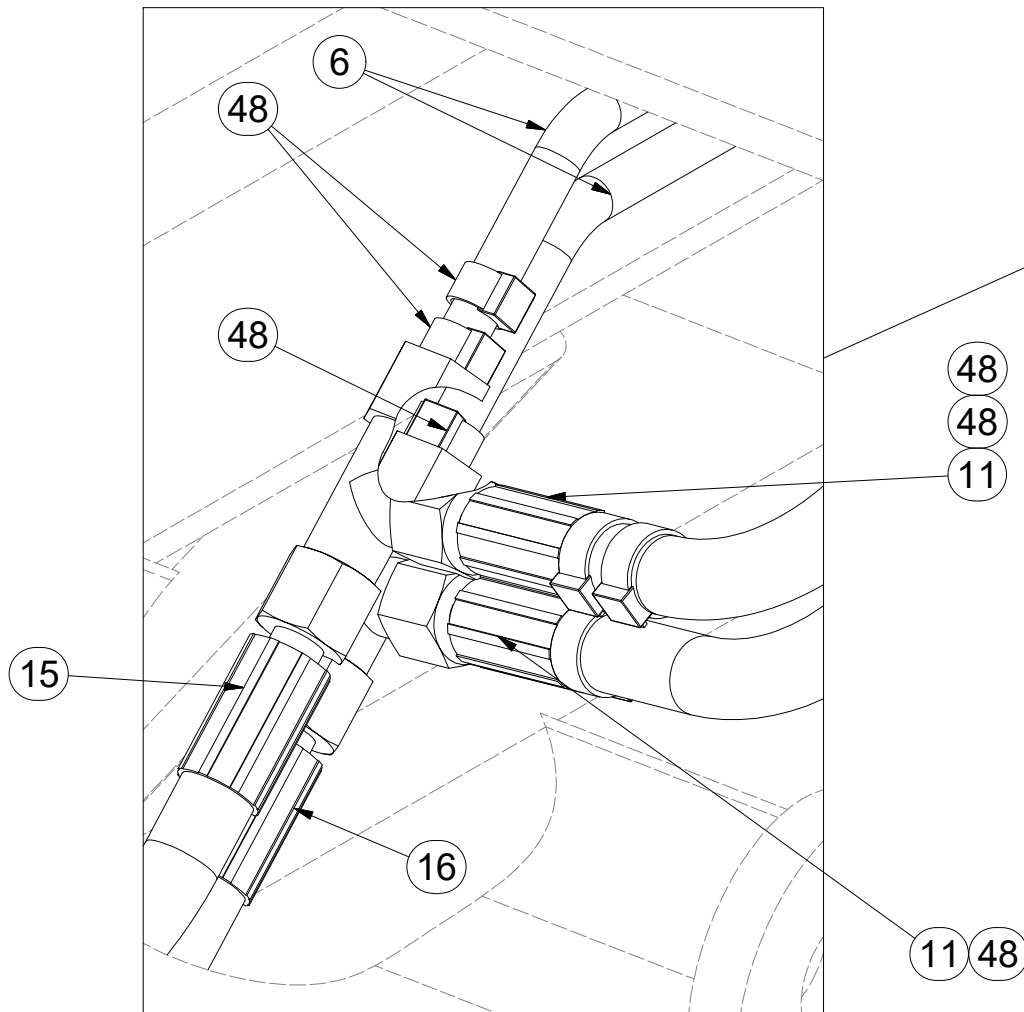
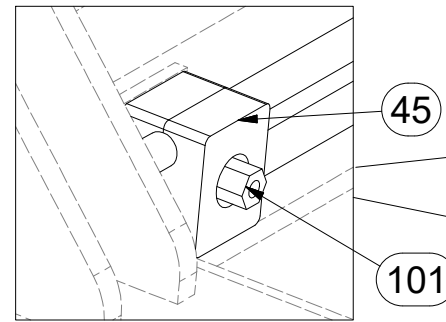

ⒸZ HYDRAULIKA STROJE

Ⓓ HYDRAULIK DER MASCHINE

Ⓕ HYDRAULIQUE DE LA MACHINE

ⒼB MACHINE HYDRAULICS

Ⓔ RU ГИДРАВЛИКА МАШИНЫ

Ⓗ PL HYDRAULIKA MASZYN



m11546

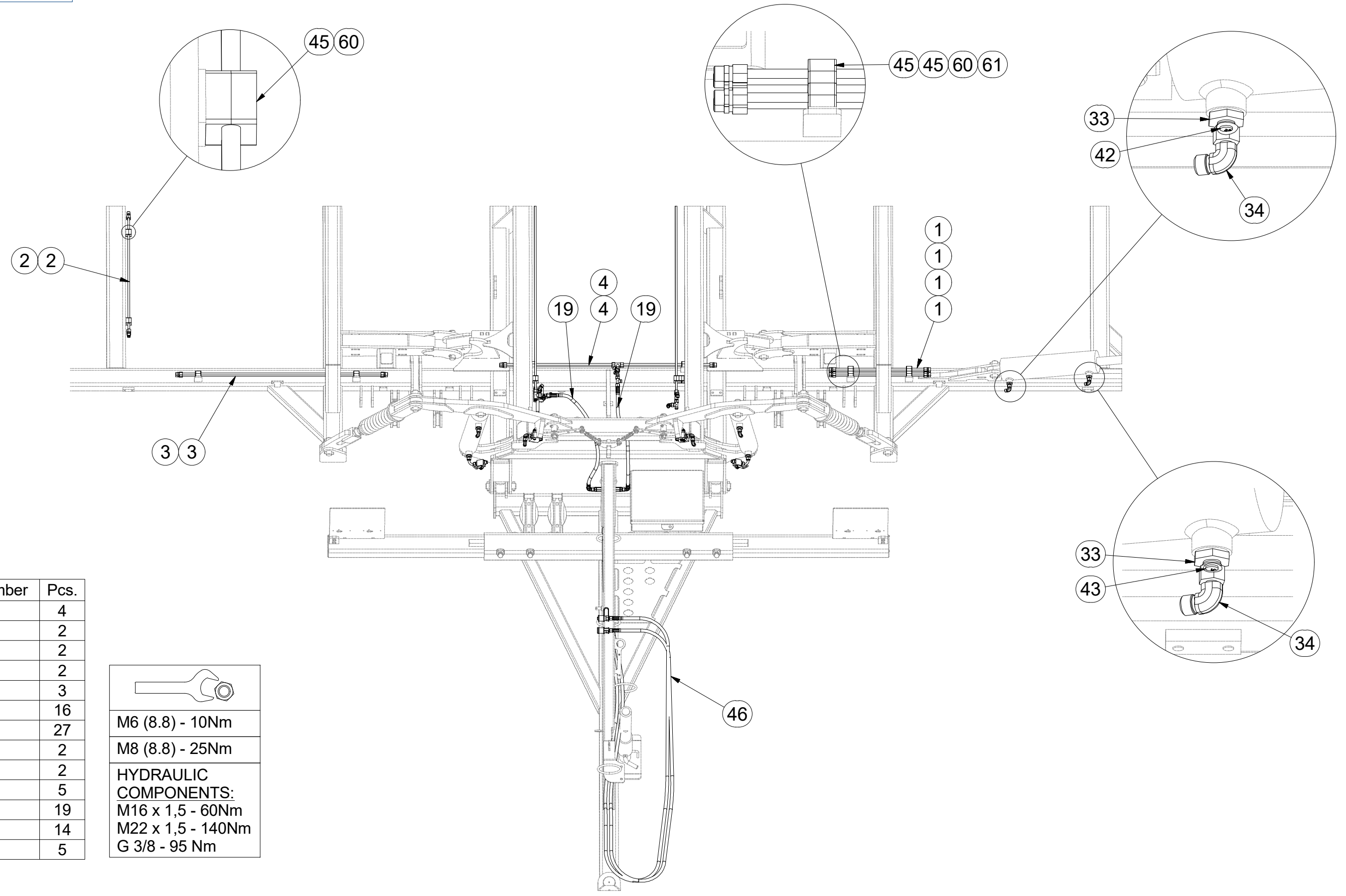

Pos.	Part Number	Pcs.
1	m10051	4
2	m10052	2
3	m10053	2
4	m10054	2
19	m07646	3
33	m09934	16
34	m06803	27
38	m04621	2
42	m10779	2
43	m10780	5
45	m05488	19
60	m04346	14
61	m04021	5

M6 (8.8) - 10Nm
M8 (8.8) - 25Nm
HYDRAULIC COMPONENTS:
M16 x 1,5 - 60Nm
M22 x 1,5 - 140Nm
G 3/8 - 95 Nm

Ⓒ HYDRAULIKA STROJE

Ⓓ HYDRAULIK DER MASCHINE

Ⓕ HYDRAULIQUE DE LA MACHINE

Ⓖ MACHINE HYDRAULICS

Ⓡ ГИДРАВЛИКА МАШИНЫ

Ⓟ HYDRAULIKA MASZYNY



m11546

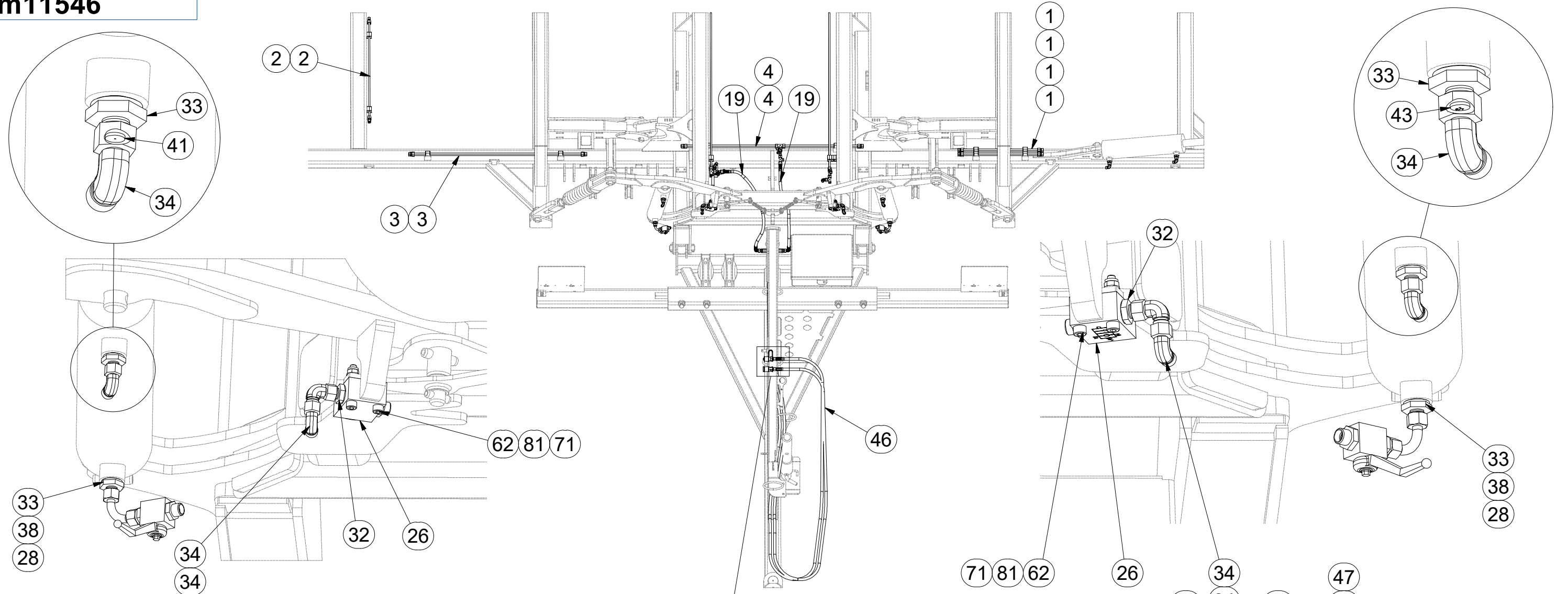

Pos.	Part Number	Pcs.	Pos.	Part Number	Pcs.
1	m10051	4	38	m04621	2
2	m10052	2	41	m10781	2
3	m10053	2	42	m10779	2
4	m10054	2	43	m10780	5
13	m04087	2	45	m05488	19
19	m07646	3	46	m11183	2
26	m10261	3	47	m11294	76
27	m06673	1	60	m04346	14
28	m04623	4	61	m04021	5
29	m03849	4	62	m05543	6
30	m04022	2	64	m05561	1
32	m06528	12	70	m05560	3
33	m09934	16	71	m04503	6
34	m06803	27	81	m01203	6

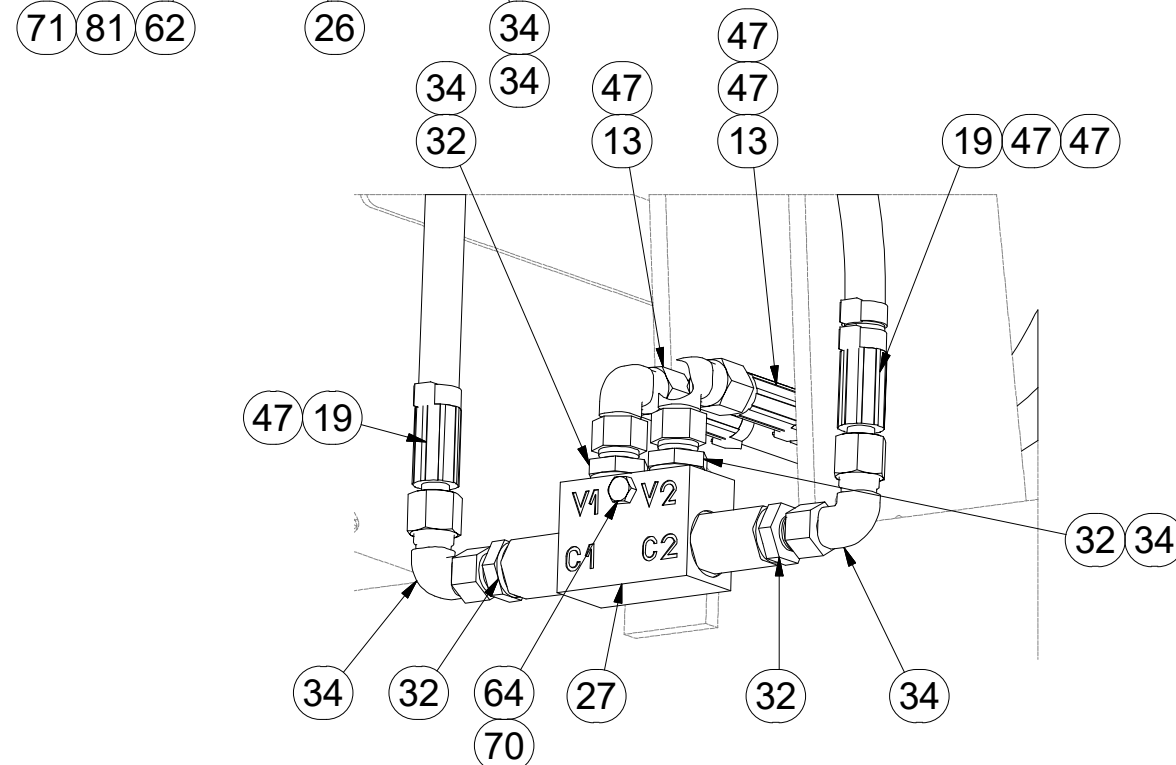
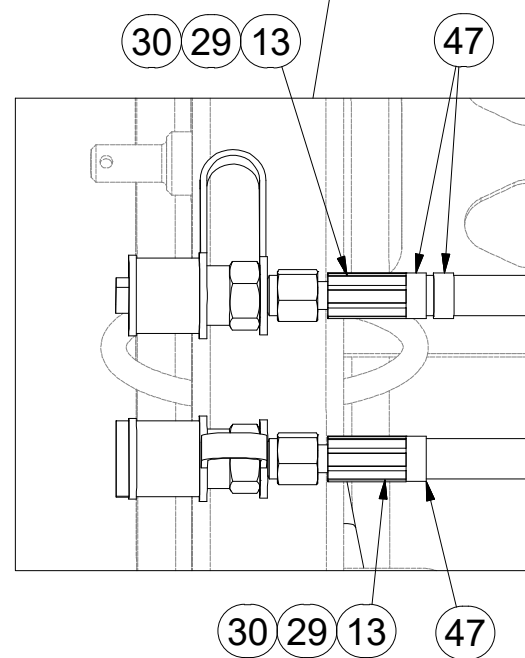

ⒸZ HYDRAULIKA STROJE

Ⓓ HYDRAULIK DER MASCHINE

Ⓕ HYDRAULIQUE DE LA MACHINE

ⒸB MACHINE HYDRAULICS

ⒸU ГИДРАВЛИКА МАШИНЫ

ⒸL HYDRAULIKA MASZYNY



m11546

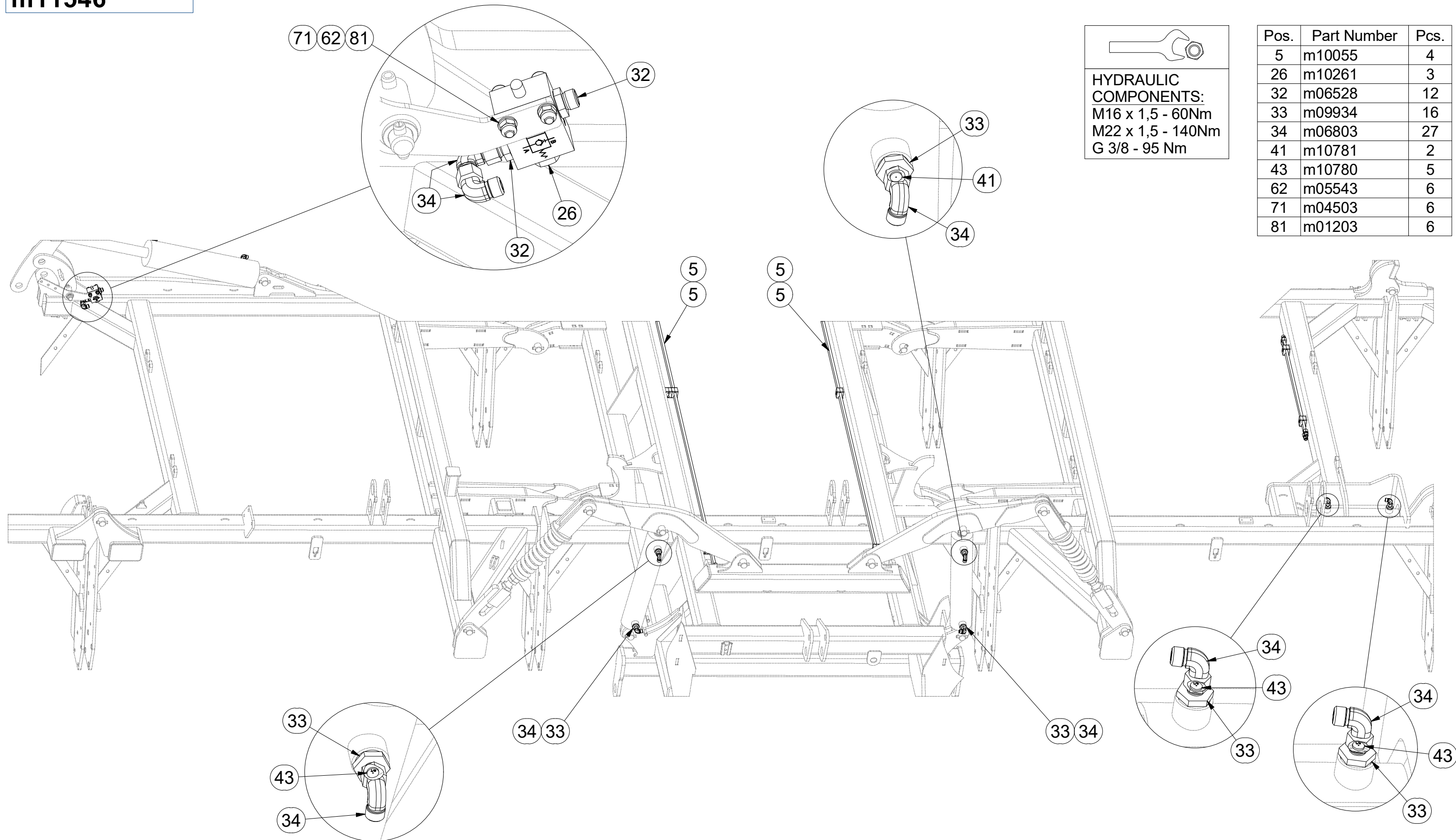

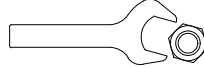

 HYDRAULIC COMPONENTS:
 M16 x 1,5 - 60Nm
 M22 x 1,5 - 140Nm
 G 3/8 - 95 Nm

Pos.	Part Number	Pcs.
5	m10055	4
26	m10261	3
32	m06528	12
33	m09934	16
34	m06803	27
41	m10781	2
43	m10780	5
62	m05543	6
71	m04503	6
81	m01203	6

m11546

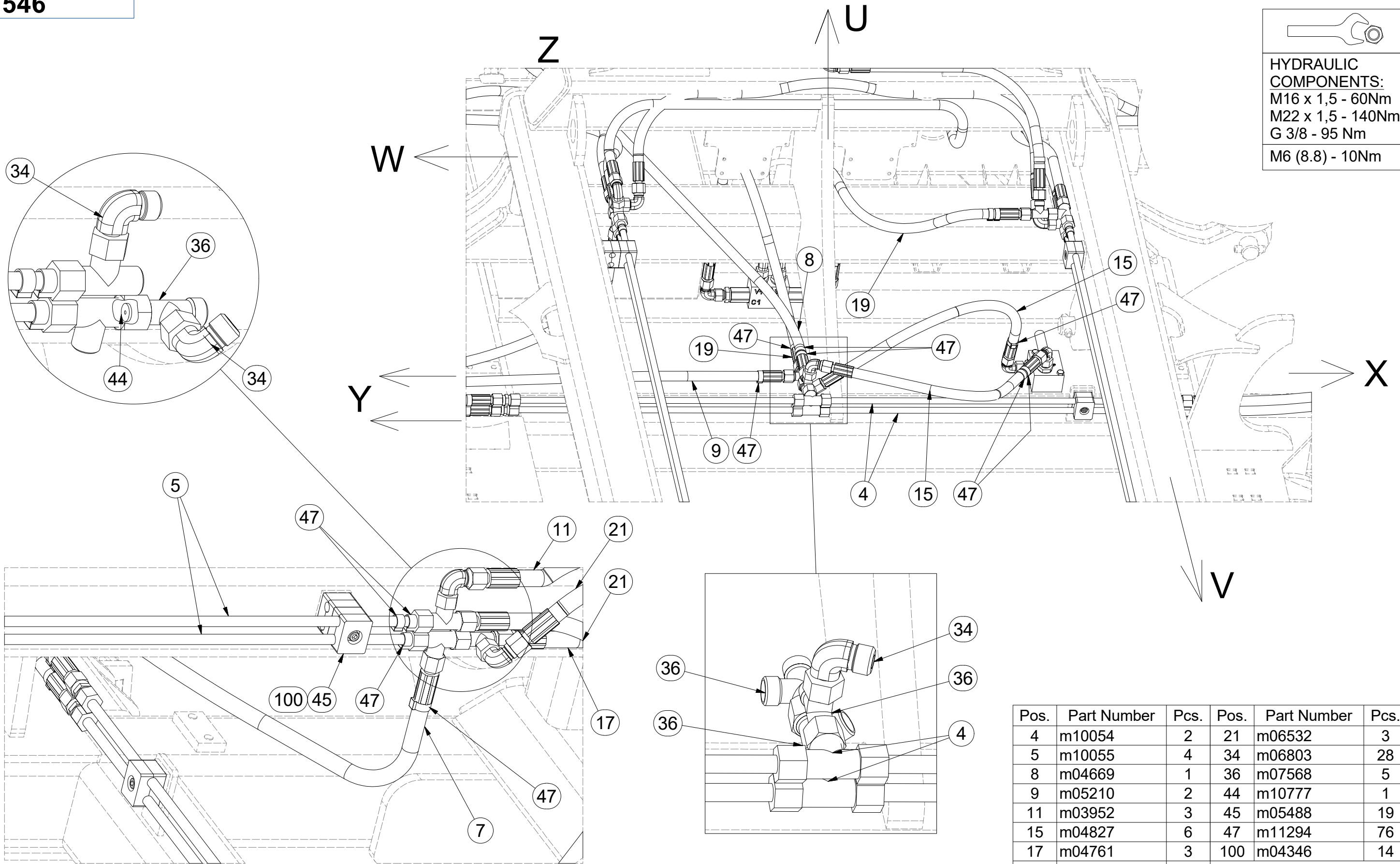
HYDRAULIC COMPONENTS:
 M16 x 1,5 - 60Nm
 M22 x 1,5 - 140Nm
 G 3/8 - 95 Nm
 M6 (8.8) - 10Nm



Pos.	Part Number	Pcs.	Pos.	Part Number	Pcs.
4	m10054	2	21	m06532	3
5	m10055	4	34	m06803	28
8	m04669	1	36	m07568	5
9	m05210	2	44	m10777	1
11	m03952	3	45	m05488	19
15	m04827	6	47	m11294	76
17	m04761	3	100	m04346	14
19	m07646	3			

Ⓒ HYDRAULIKA STROJE

Ⓓ HYDRAULIK DER MASCHINE

Ⓕ HYDRAULIQUE DE LA MACHINE

Ⓖ MACHINE HYDRAULICS

Ⓡ ГИДРАВЛИКА МАШИНЫ

Ⓟ HYDRAULIKA MASZYNY



m11546

Pos.	Part Number	Pcs.	Pos.	Part Number	Pcs.
4	m10054	2	36	m07568	5
8	m04669	1	37	m06529	1
9	m05210	2	42	m10779	2
15	m04827	6	45	m05488	19
17	m04761	3	47	m11294	76
19	m07646	3	100	m04346	14
21	m06532	3	103	m04842	2
24	m08910	1	110	m05560	3
32	m06528	12	120	m01199	2
34	m06803	28			

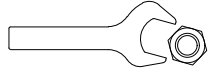

HYDRAULIC COMPONENTS:
M16 x 1,5 - 60Nm
M22 x 1,5 - 140Nm
G 3/8 - 95 Nm
M6 (8.8) - 10Nm

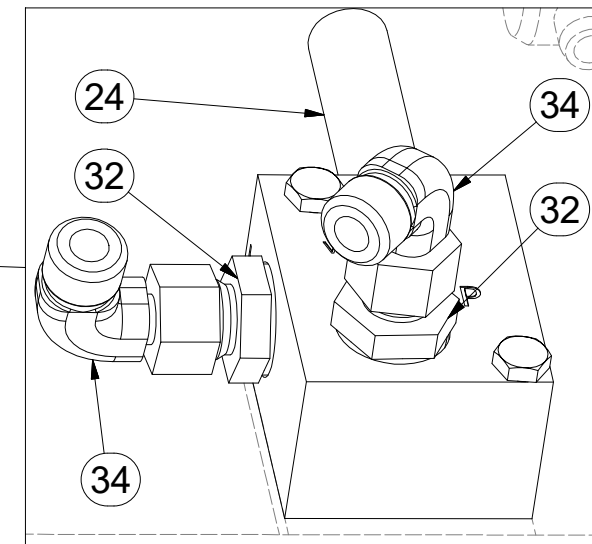
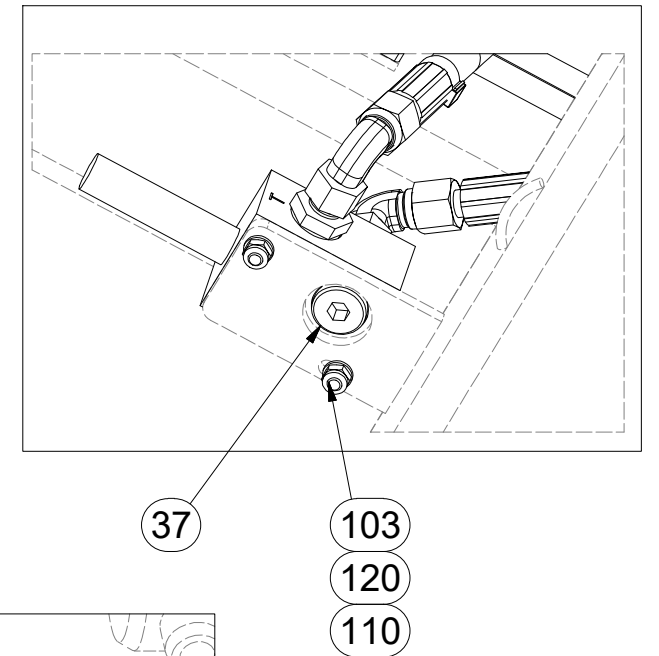
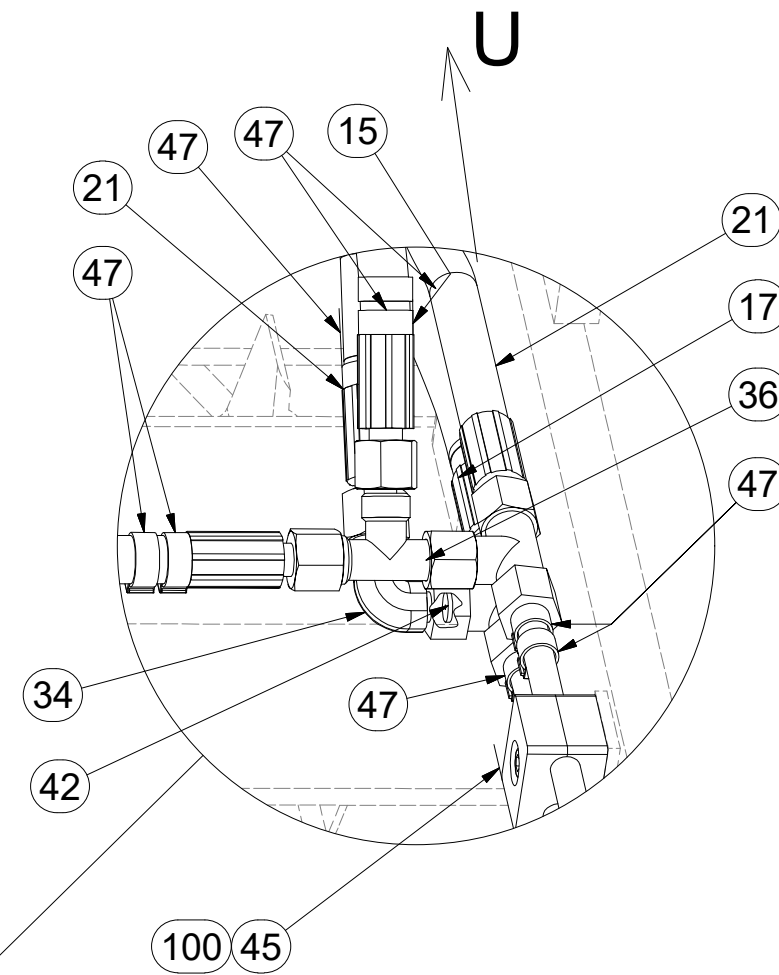
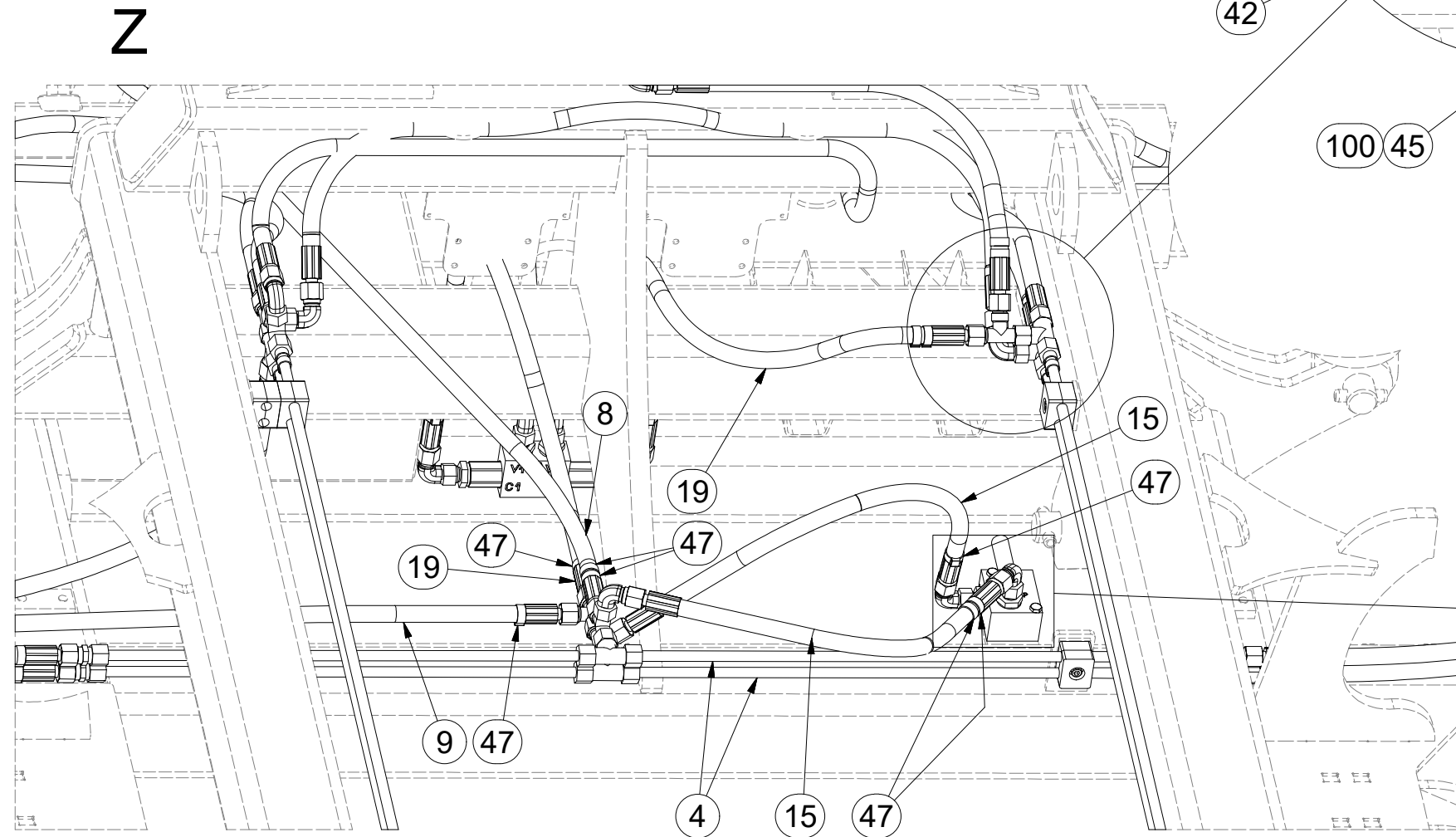

Ⓒ HYDRAULIKA STROJE

Ⓓ HYDRAULIK DER MASCHINE

Ⓕ HYDRAULIQUE DE LA MACHINE

Ⓖ MACHINE HYDRAULICS

Ⓡ ГИДРАВЛИКА МАШИНЫ

Ⓟ HYDRAULIKA MASZYNY

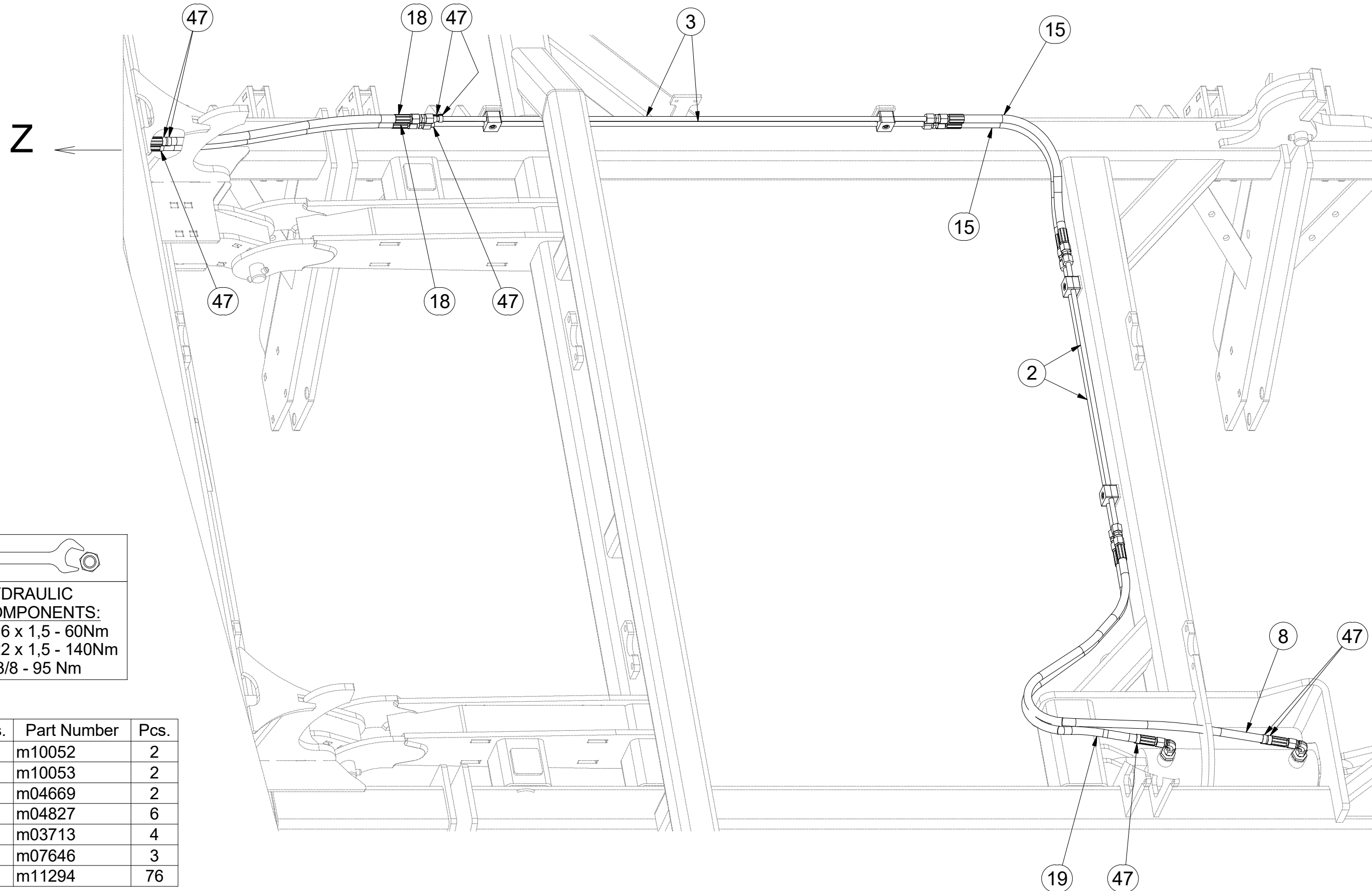
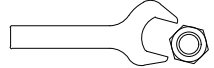

m11546

HYDRAULIC COMPONENTS:
M16 x 1,5 - 60Nm
M22 x 1,5 - 140Nm
G 3/8 - 95 Nm

Pos.	Part Number	Pcs.
2	m10052	2
3	m10053	2
8	m04669	2
15	m04827	6
18	m03713	4
19	m07646	3
47	m11294	76

m11546

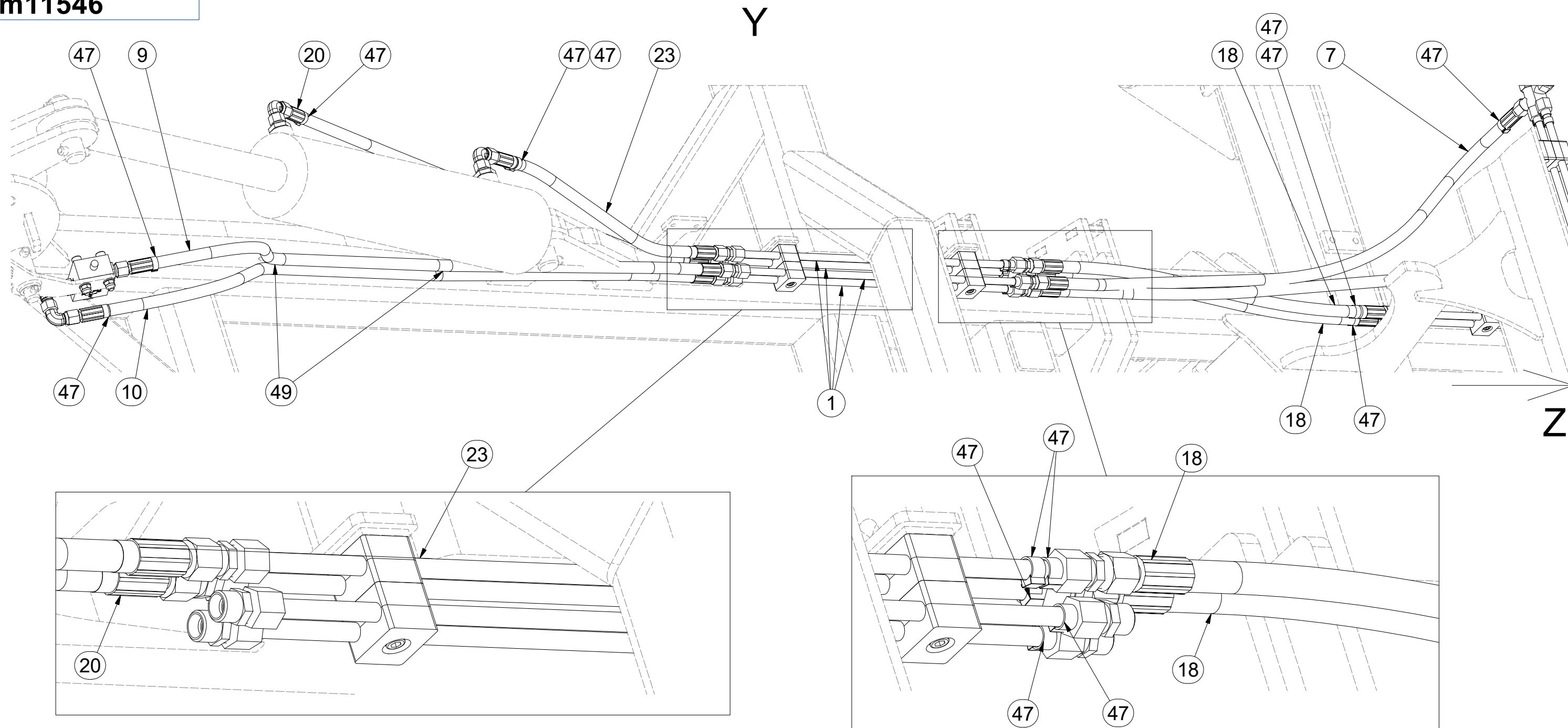

Pos.	Part Number	Pcs.
1	m10051	4
7	m03951	1
9	m05210	2
10	m07504	1
18	m03713	4
20	m07364	1
23	m11126	1
47	m11294	76

Ⓒ HYDRAULIKA STROJE

Ⓓ HYDRAULIK DER MASCHINE

Ⓕ HYDRAULIQUE DE LA MACHINE

Ⓖ MACHINE HYDRAULICS

Ⓡ ГИДРАВЛИКА МАШИНЫ

Ⓟ HYDRAULIKA MASZYNY



m11546

Pos.	Part Number	Pcs.
11	m03952	3
15	m04827	6
17	m04761	3
21	m06532	3
25	m07363	2
34	m06803	28
35	m03889	1
47	m11294	76
49	m01637	15



HYDRAULIC COMPONENTS:
M16 x 1,5 - 60Nm
M22 x 1,5 - 140Nm
G 3/8 - 95 Nm

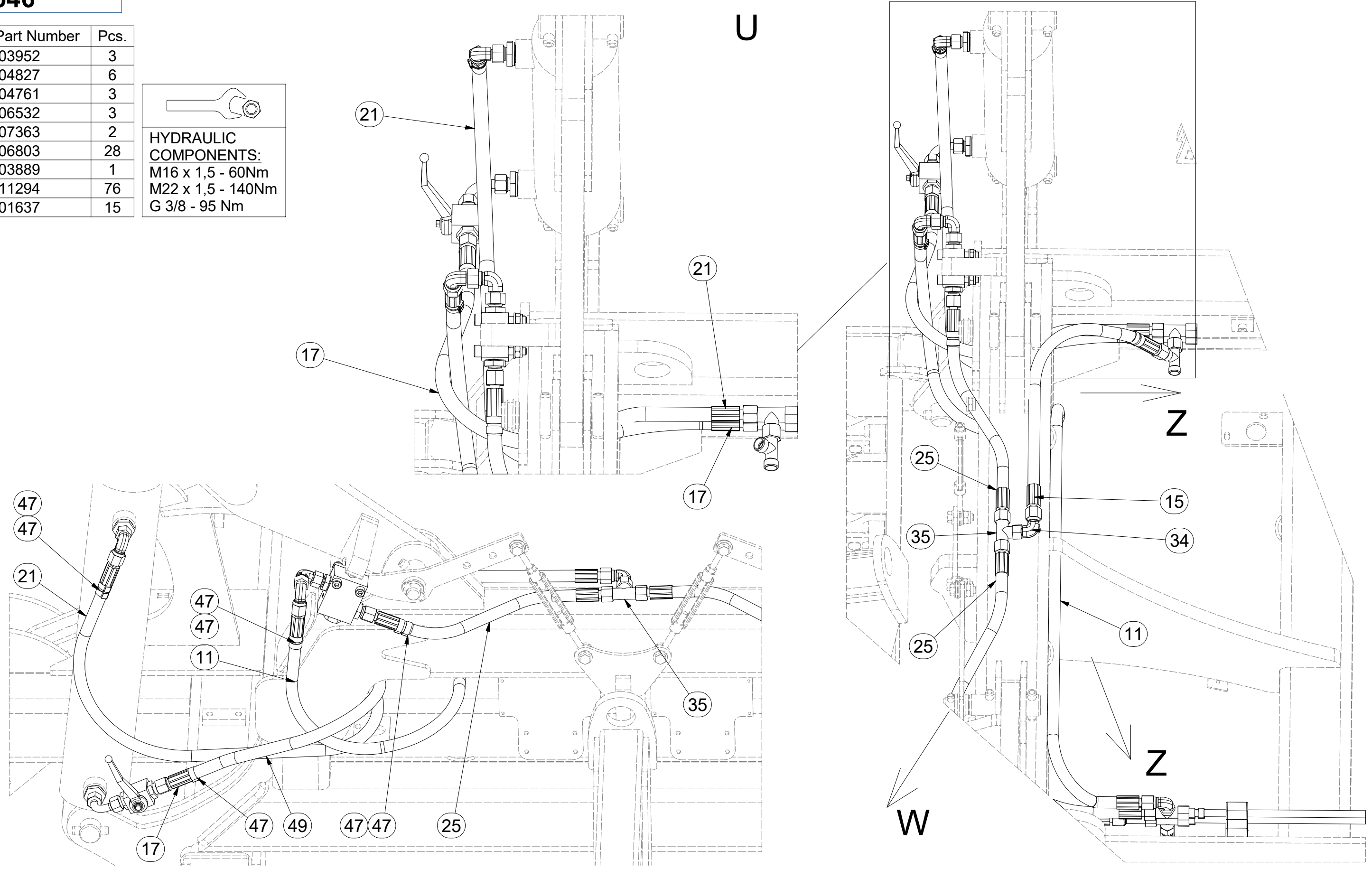

m11546

W

HYDRAULIC COMPONENTS:
 M16 x 1,5 - 60Nm
 M22 x 1,5 - 140Nm
 G 3/8 - 95 Nm

Pos.	Part Number	Pcs.
8	m04669	1
15	m04827	6
17	m04761	3
21	m06532	3
25	m07363	2
35	m03889	1
47	m11294	76
49	m01637	15

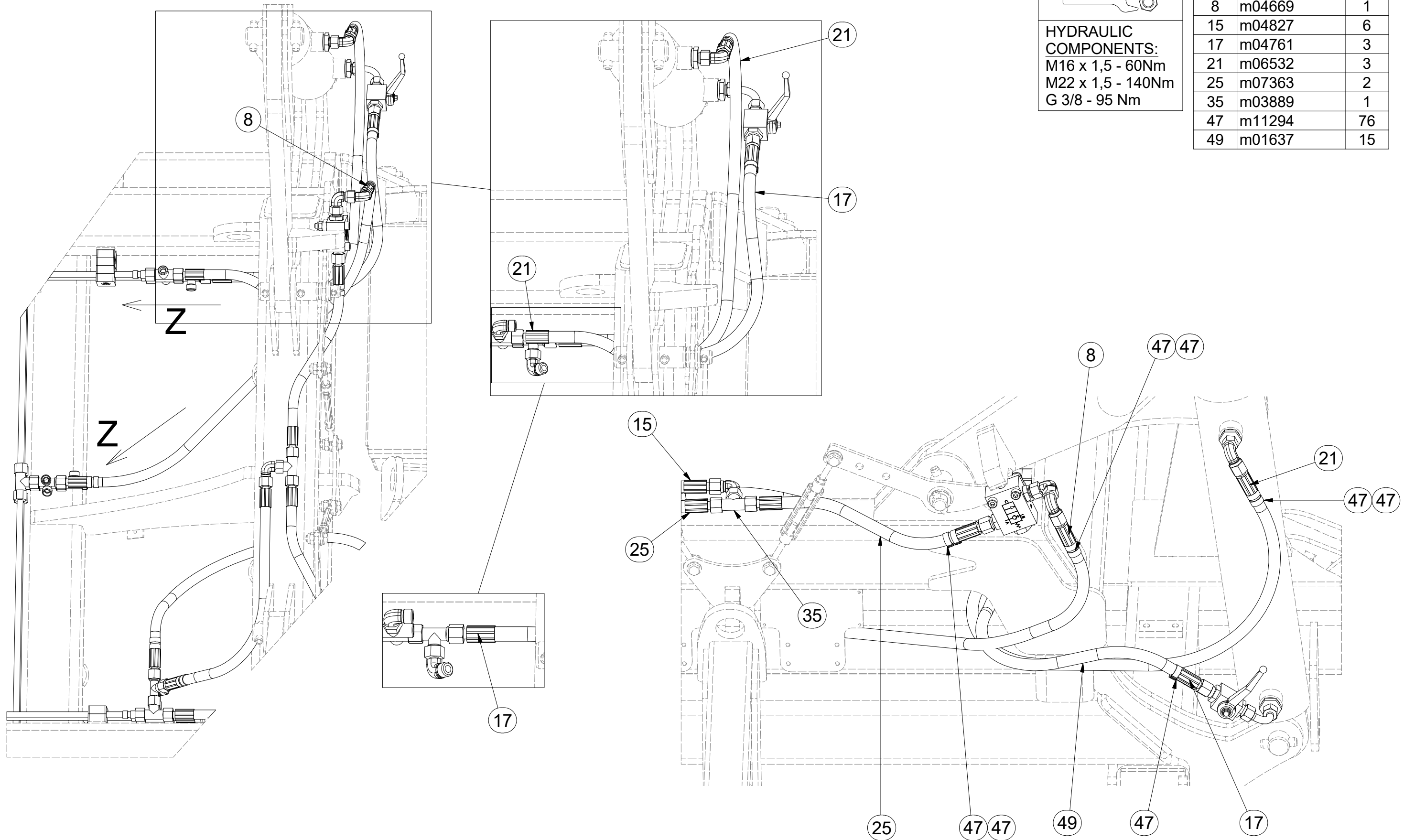

m11546

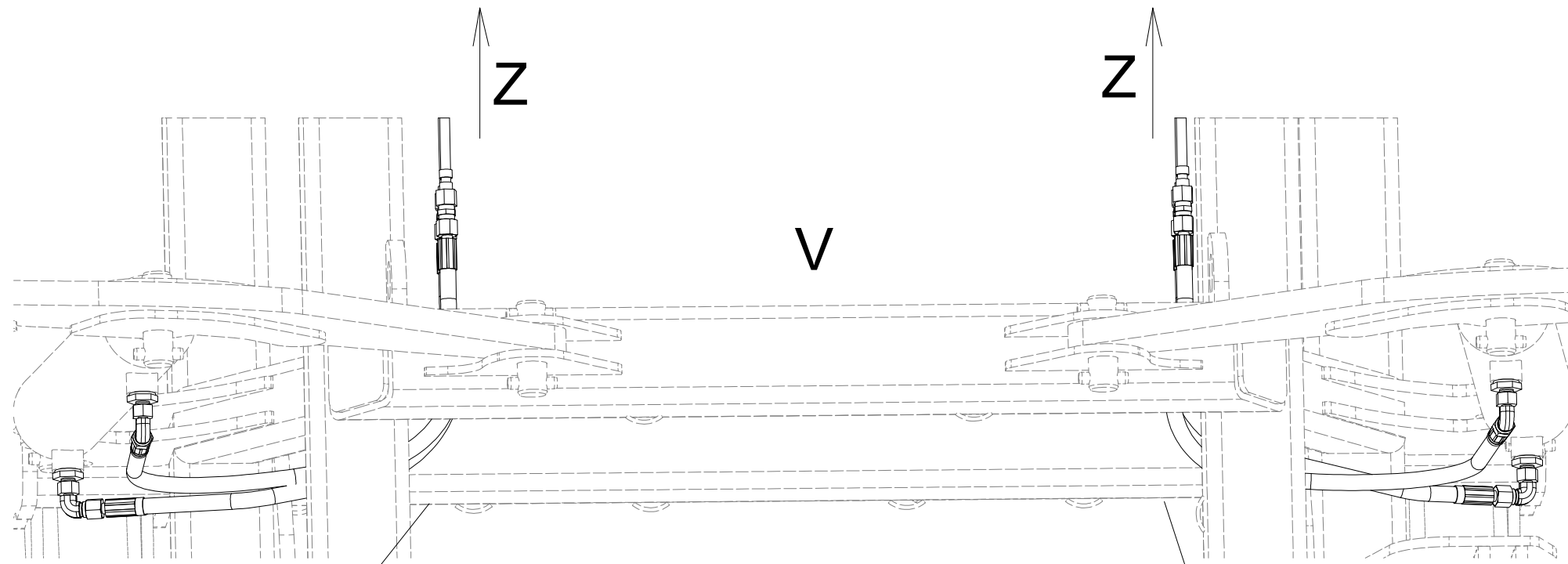

Pos.	Part Number	Pcs.
16	m09628	2
17	m04761	3
22	m04033	2
47	m11294	76
49	m01637	15

HYDRAULIC COMPONENTS:
 M16 x 1,5 - 60Nm
 M22 x 1,5 - 140Nm
 G 3/8 - 95 Nm

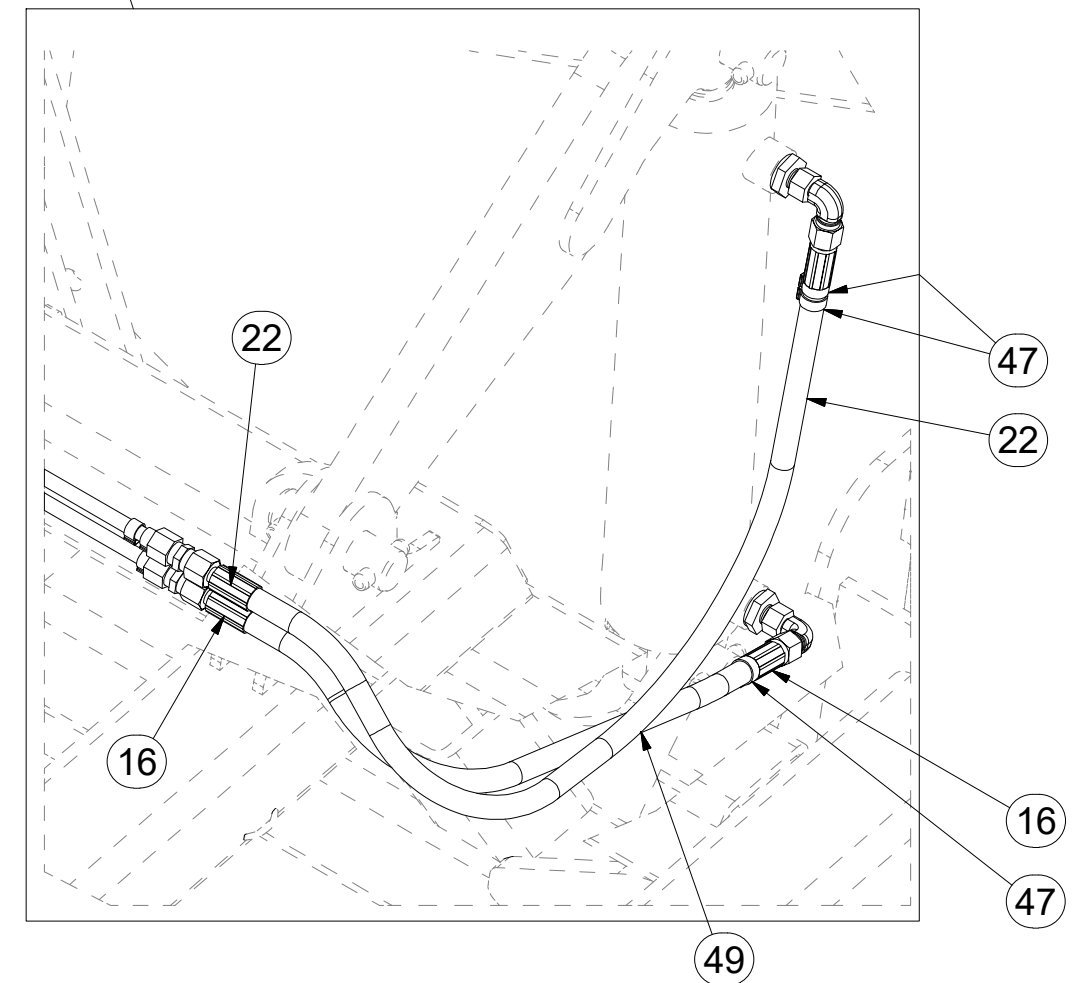
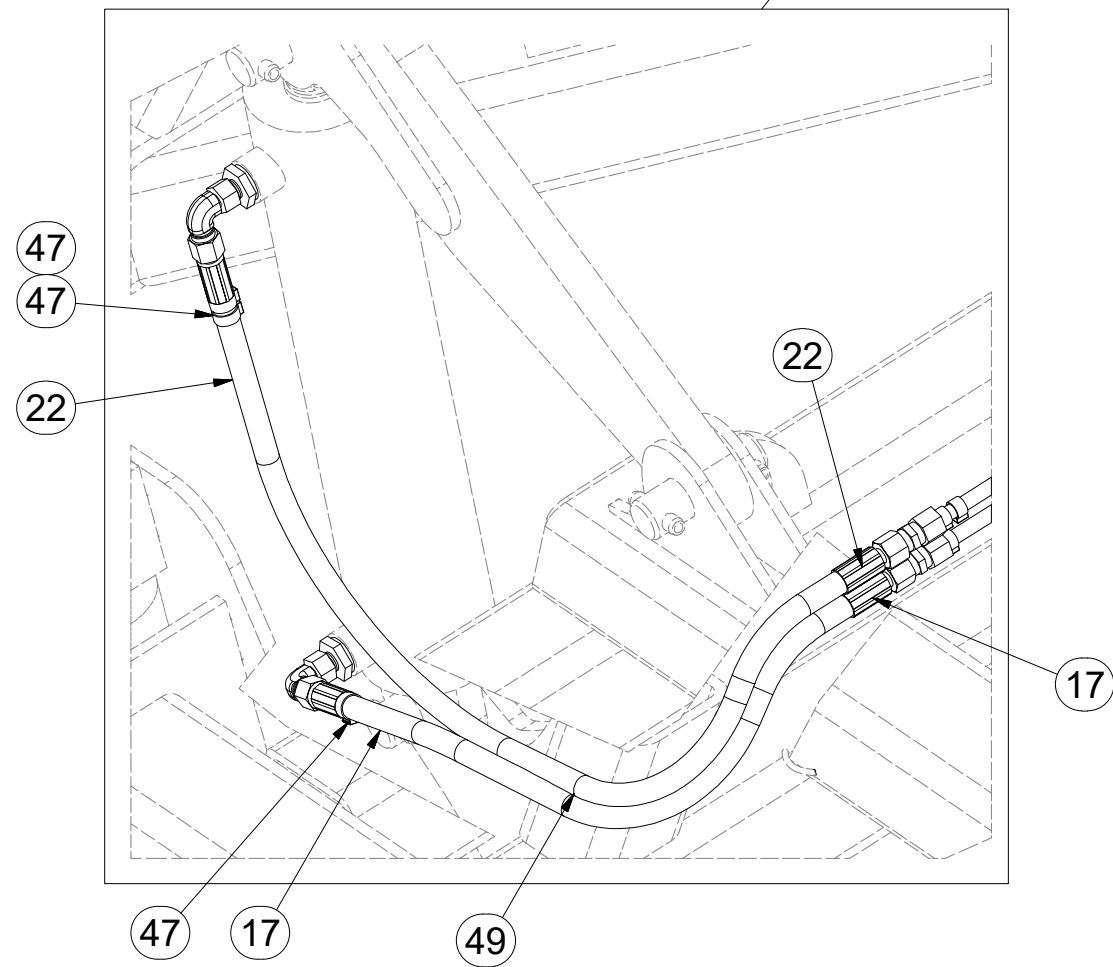

Ⓒ SAMOLEPKY STROJE

Ⓓ AUFKLEBER MASCHINEN

Ⓕ VOITURE MACHINES

Ⓖ STICKERS MACHINES

Ⓡ СТИКЕРЫ МАШИНЫ

Ⓟ NAKLEJKI MASZYNY



m11543

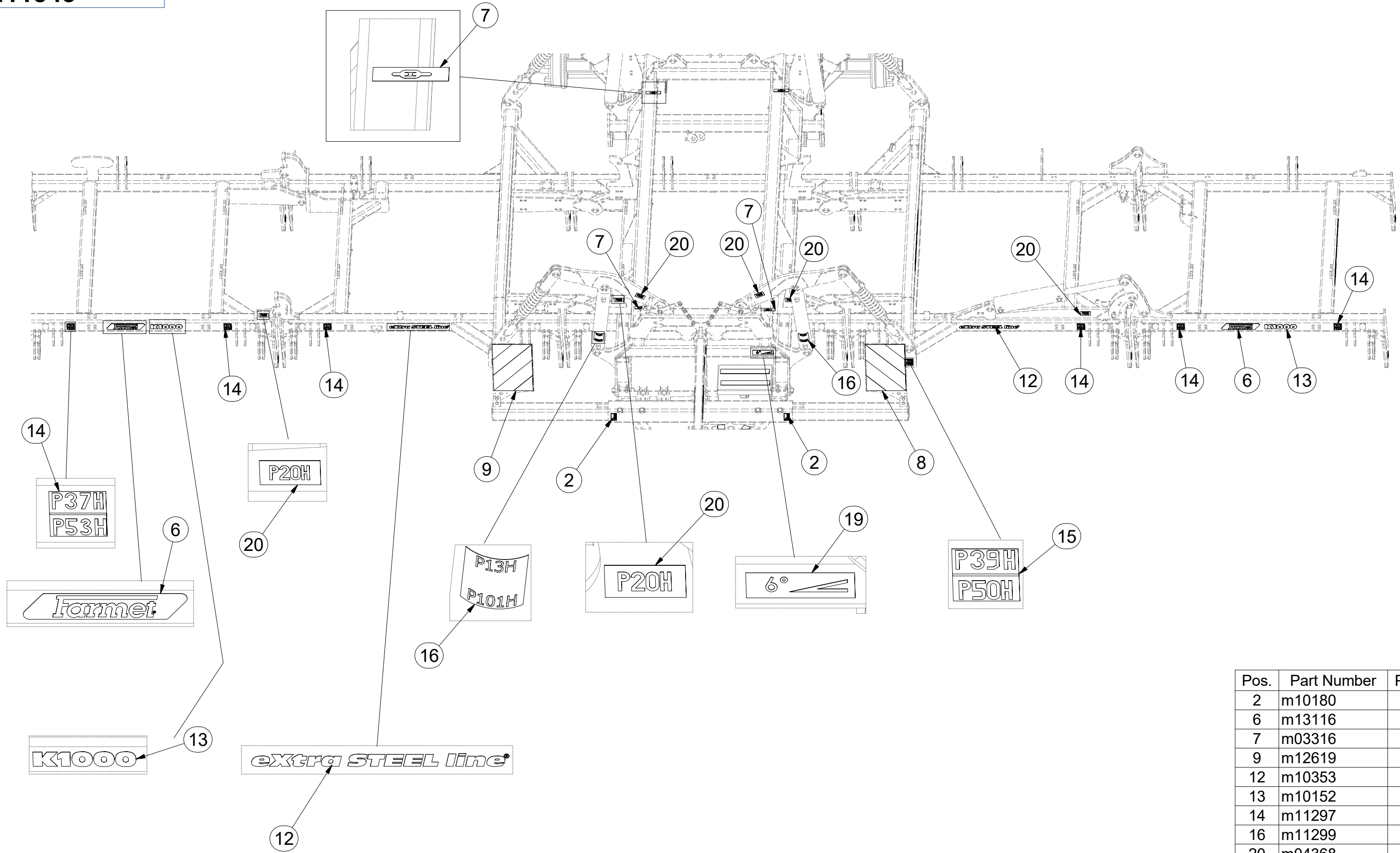

Pos.	Part Number	Pcs.
2	m10180	3
6	m13116	8
7	m03316	6
9	m12619	1
12	m10353	6
13	m10152	4
14	m11297	12
16	m11299	4
20	m04368	12

Ⓒ SAMOLEPKY STROJE

Ⓓ AUFKLEBER MASCHINEN

Ⓕ VOITURE MACHINES

Ⓖ STICKERS MACHINES

Ⓡ СТИКЕРЫ МАШИНЫ

Ⓟ NAKLEJKI MASZYNY



m11543

Pos.	Part Number	Pcs.
2	m10180	3
3	m03320	6
4	m07688	5
5	m11291	1
6	m13116	8
7	m03316	6
12	m10353	6
18	m11147	2
20	m04368	12
21	m11146	2
24	m13708	5
25	m09655	20

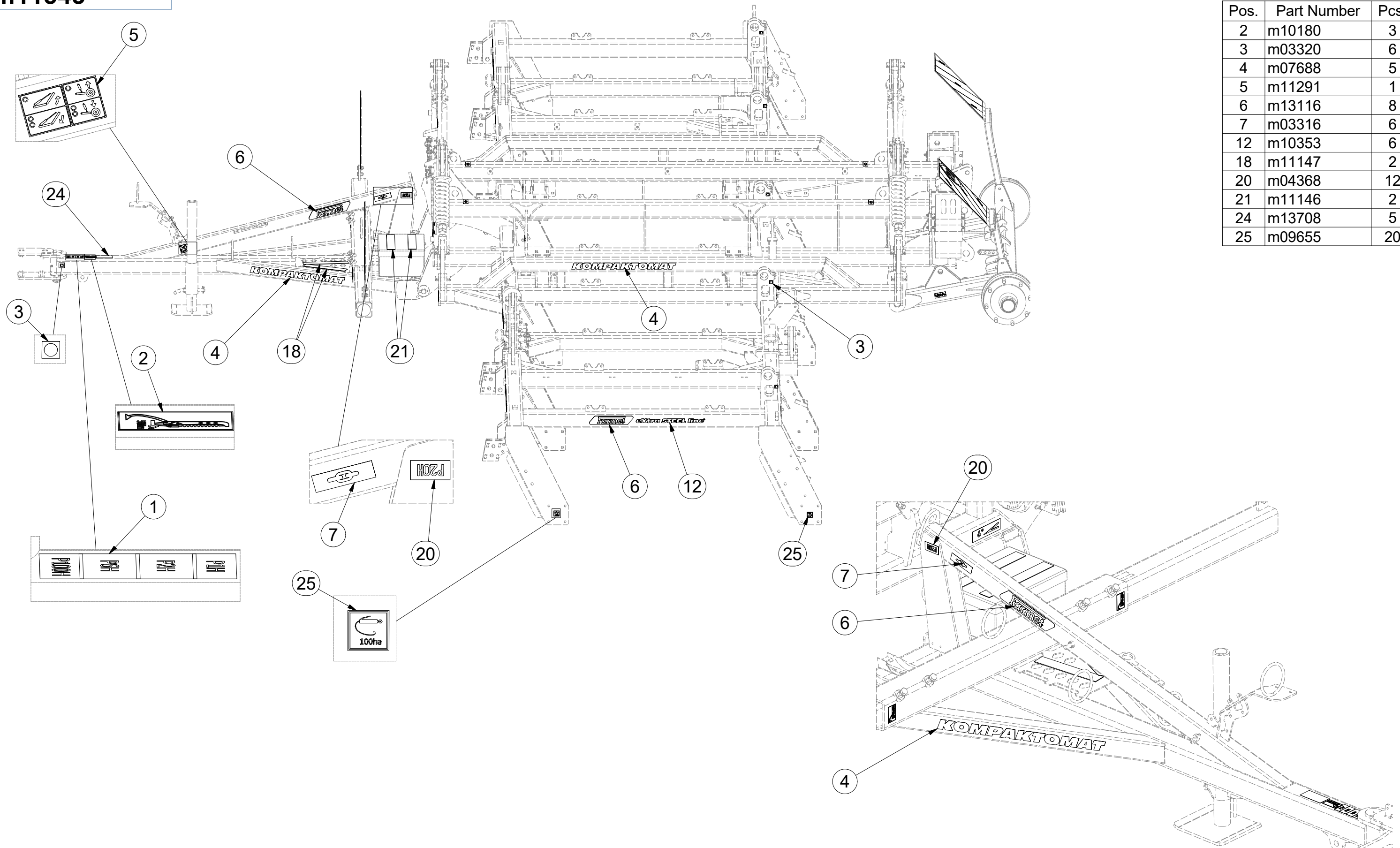

- Ⓒ SAMOLEPKY STROJE
- Ⓓ AUFKLEBER MASCHINEN
- Ⓕ VOITURE MACHINES

- Ⓖ STICKERS MACHINES
- Ⓡ СТИКЕРЫ МАШИНЫ
- Ⓟ NAKLEJKI MASZYNY



m11543

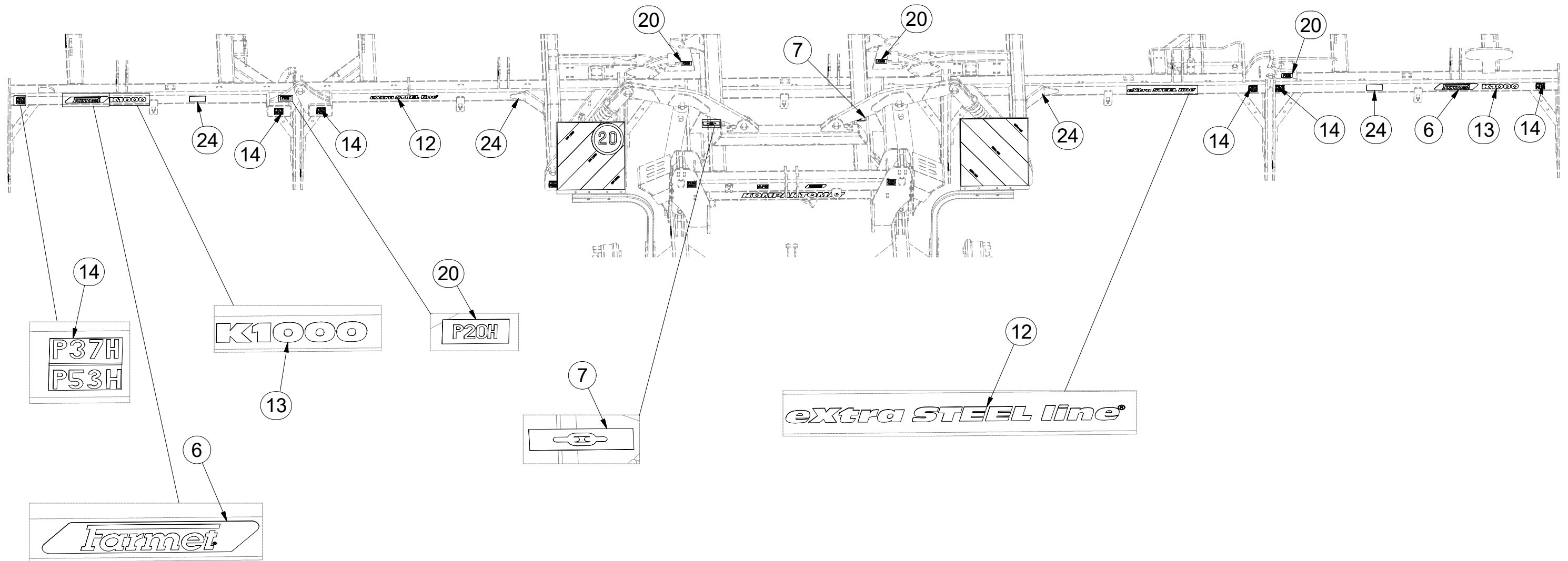

Pos.	Part Number	Pcs.
6	m13116	8
7	m03316	6
12	m10353	6
13	m10152	4
14	m11297	12
20	m04368	12
24	m13708	5

☉ SAMOLEPKY STROJE

☉ AUFKLEBER MASCHINEN

☉ VOITURE MACHINES

☉ STICKERS MACHINES

☉ СТИКЕРЫ МАШИНЫ

☉ NAKLEJKI MASZYNY



m11543

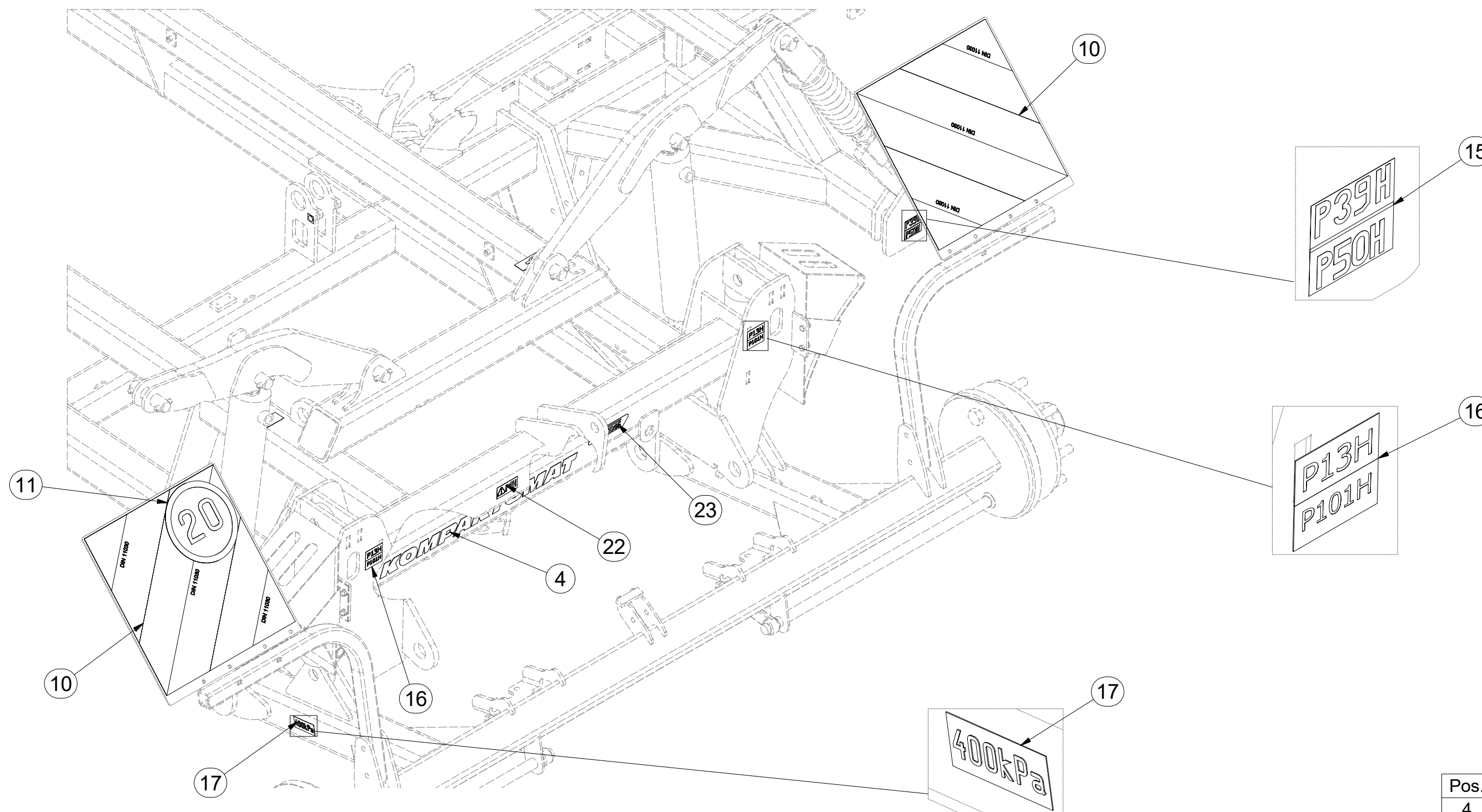

Pos.	Part Number	Pcs.
4	m07688	5
10	m12401	2
11	m04406	1
15	m11296	4
16	m11299	4
17	m04887	2
22	m04359	1
23	m13401	1

Ⓒ TÁHLO SKLÁPĚNÍ

Ⓓ ZUGSTANGE ZUR KIPPUNG

Ⓕ TIGE DU BASCULEMENT

Ⓖ TILTING PULL ROD

Ⓡ ТЯГА СКЛАДЫВАНИЯ

Ⓟ CIĘGŁO PRZECHYLANIA



4005363

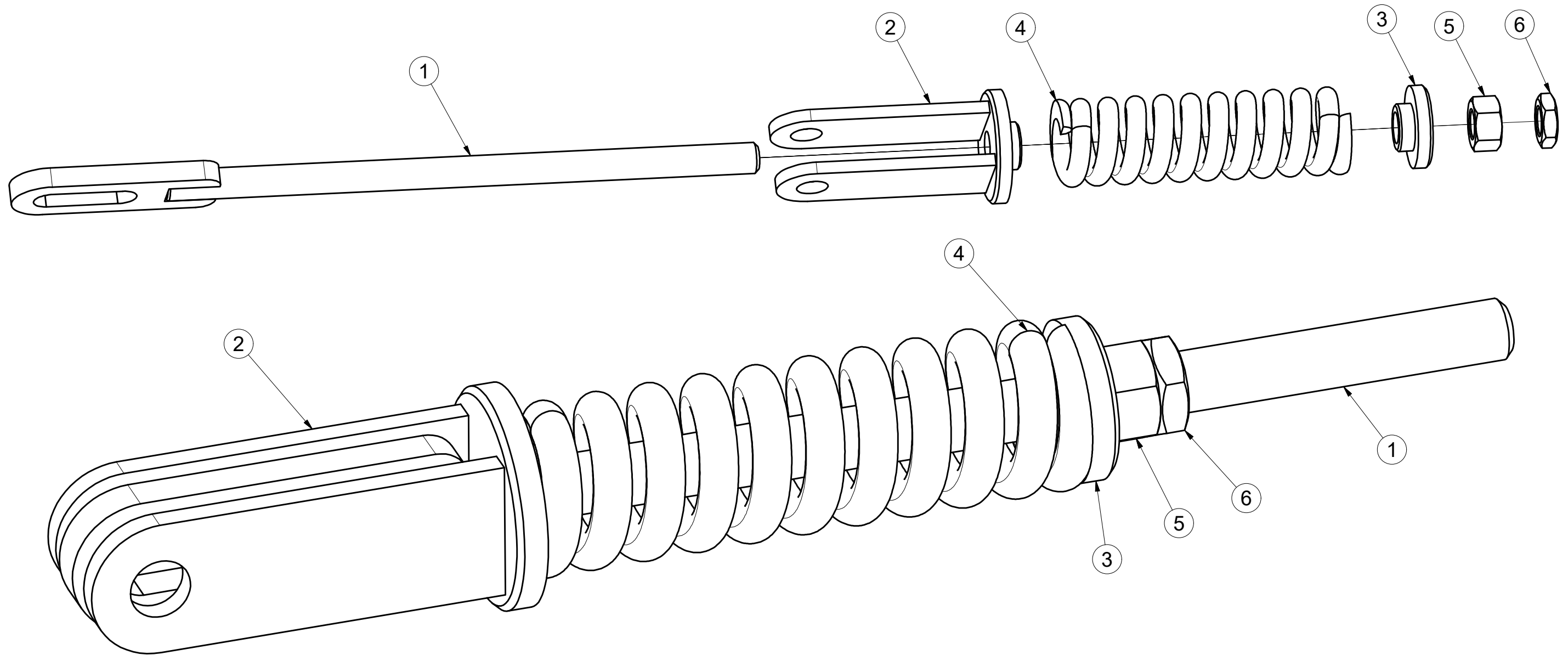

Pos	Part Number	Pcs.
1	4005358	1
2	4005361	1
3	4000023	1
5	m01309	1
4	m06482	1
6	m04043	1

CZ NASAZOVACÍ KLIKA
 D EINSTELLKURBEL
 F MANIVELLE AMOVIBILE

GB PRESS-ON HANDLE
 RU НАСАЖИВАЕМАЯ РУКОЯТКА
 PL KLAMKA MOCOWANA



4003087

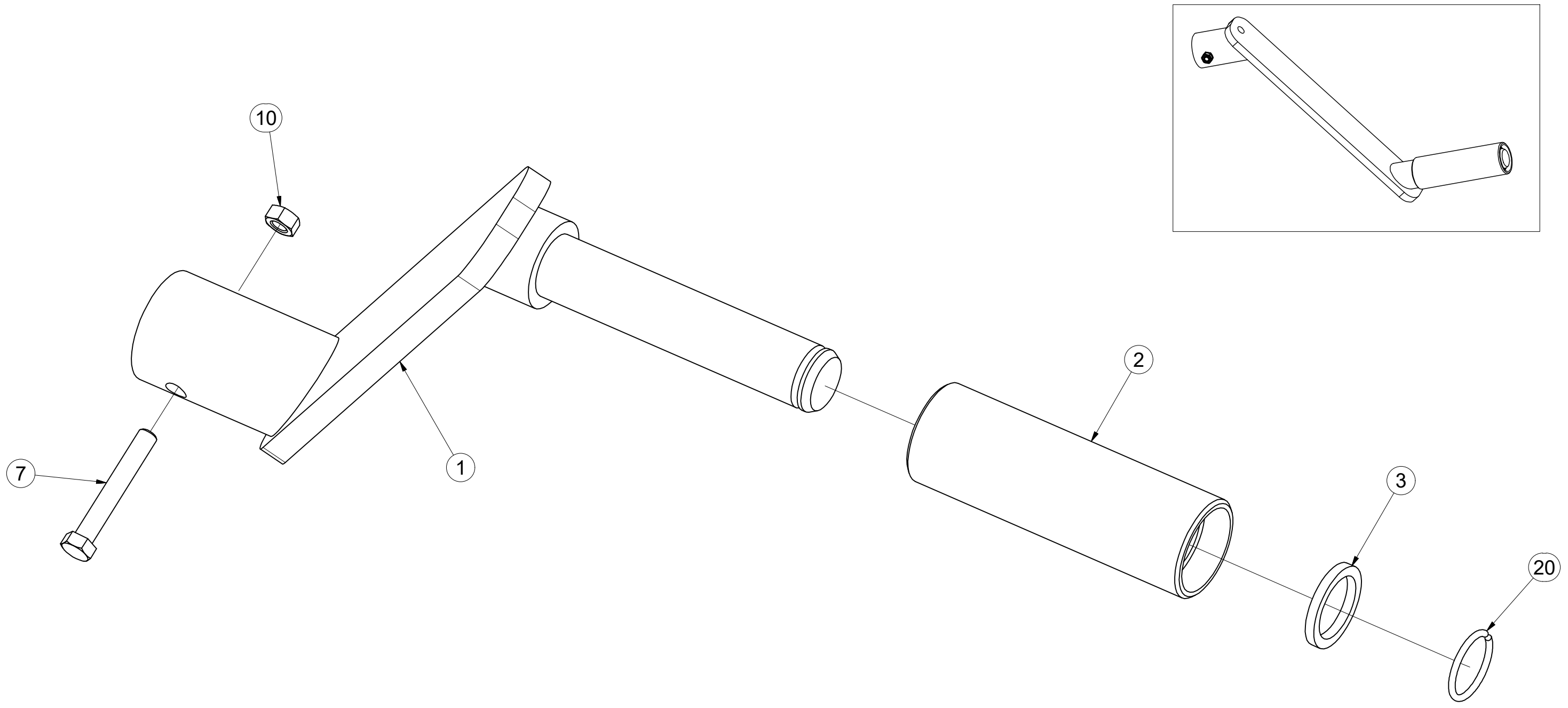

Pos.	Part Number	Pcs.
1	4003092	1
2	4001533	1
3	4004828	1
7	m04641	1
10	m01295	1
20	m06561	1

☞ SADA ČEPŮ TBZ 3

☞ BOLZENSATZ TBZ 3

☞ KIT D'EMBOUITS TBZ 3

3005554

☞ SET OF TBZ 3 PINS

☞ КОМПЛЕКТ ПАЛЬЦЕВ TBZ 3

☞ ZESTAW CZOPÓW TBZ 3

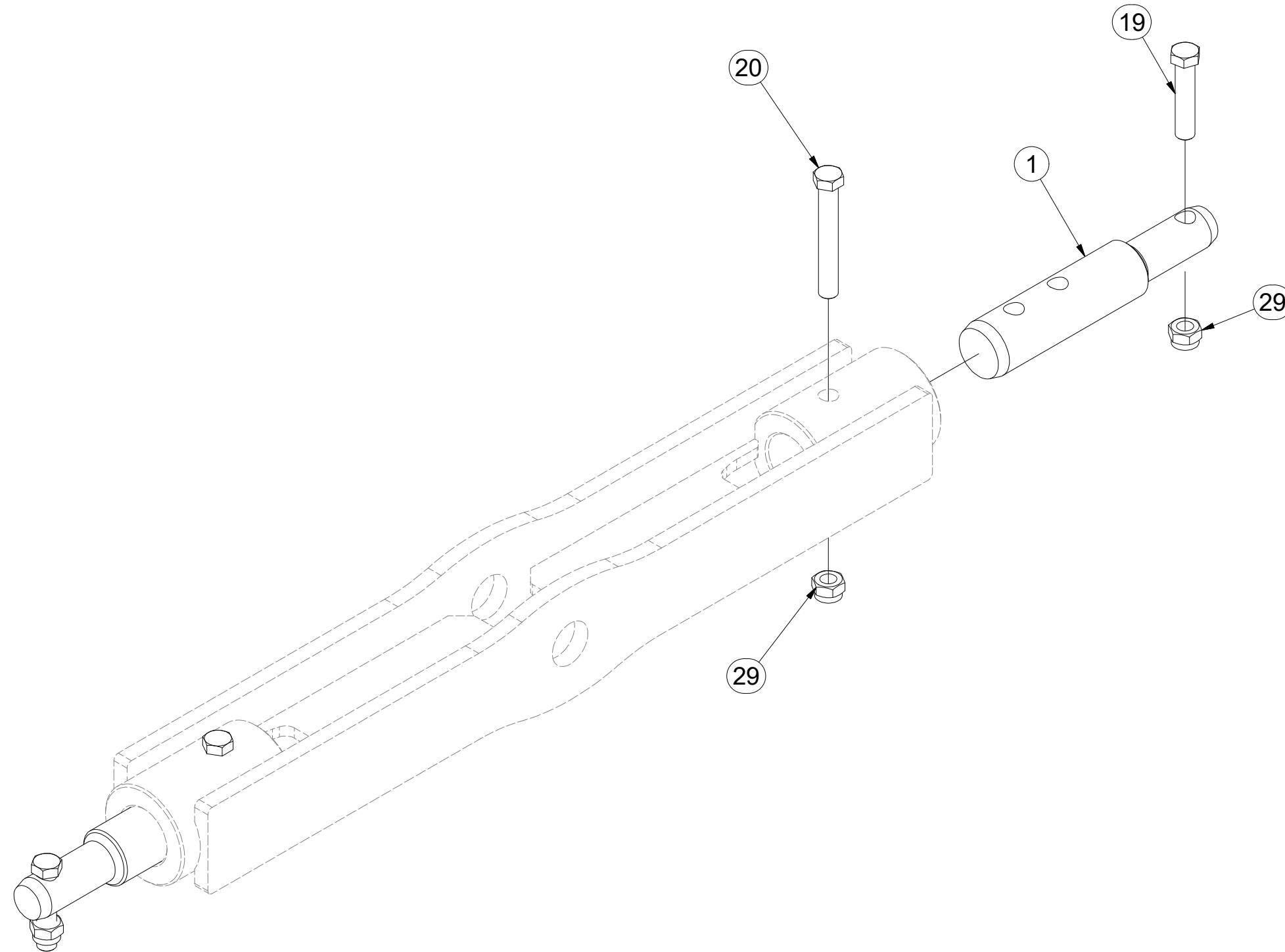
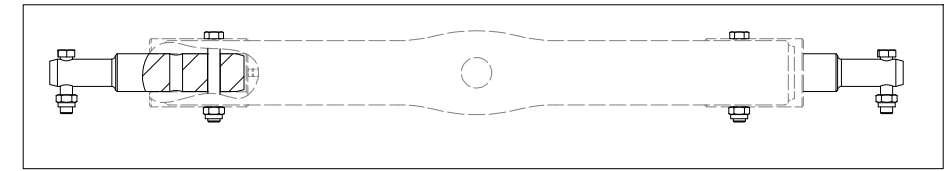
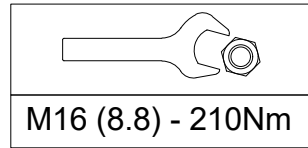

Pos.	Part Number	Pcs.
1	4007412	2
19	m01133	2
20	m02970	2
29	m03683	4

Ⓒ SADA KYPŘIČŮ STOP

Ⓓ SPURENLOCKERERSATZ

Ⓕ KIT DE CULTIVATEURS DE TRACES

Ⓖ SET OF TRACK CULTIVATORS

Ⓡ КОМПЛЕКТ РЫХЛИТЕЛЕЙ КОЛЕИ

Ⓟ ZESTAW SPULCHNIACZY ŚLADÓW



3005535

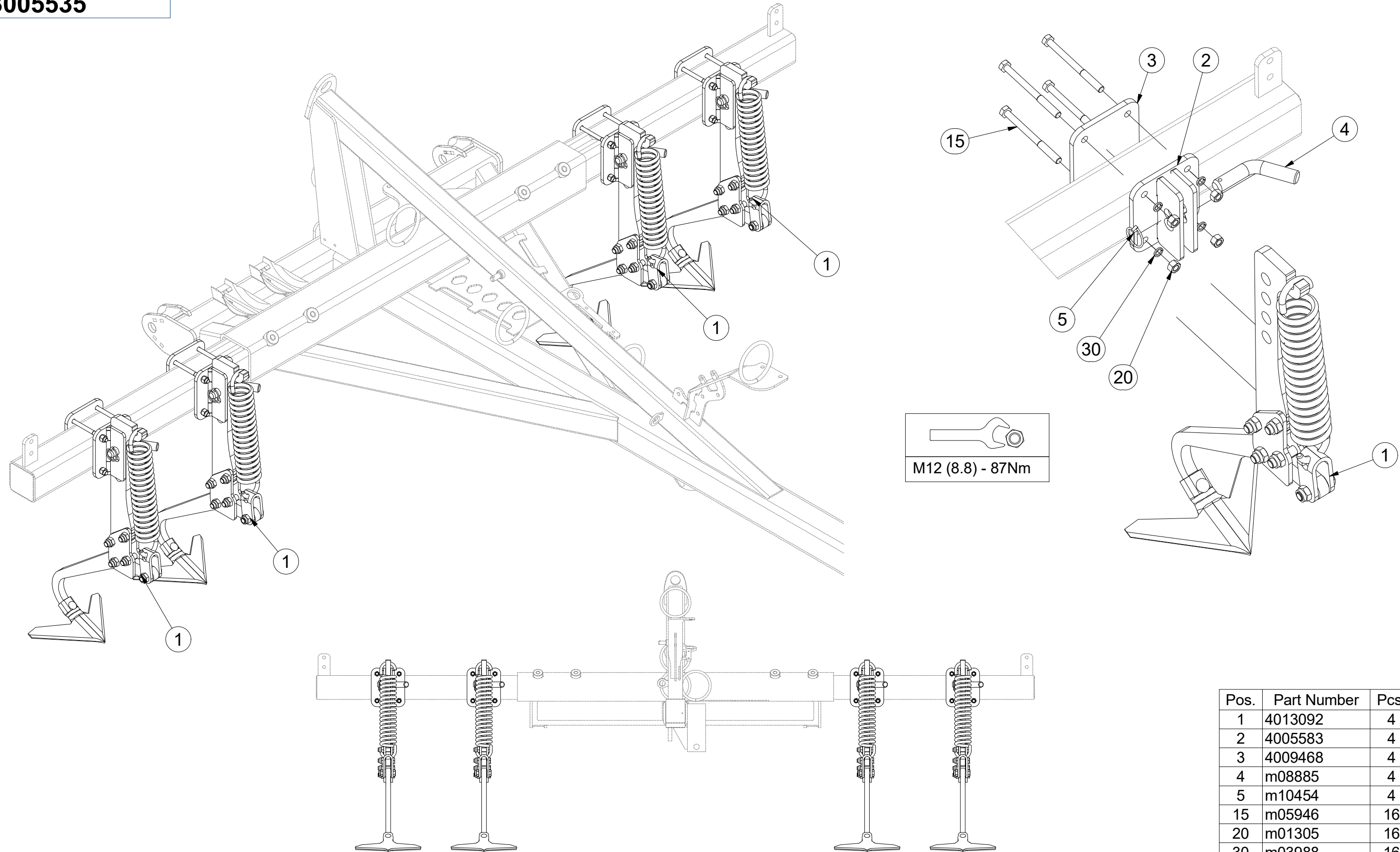

Pos.	Part Number	Pcs.
1	4013092	4
2	4005583	4
3	4009468	4
4	m08885	4
5	m10454	4
15	m05946	16
20	m01305	16
30	m03988	16

Ⓒ KYPŘIČ STOP

Ⓓ SPURENLOCKERER

Ⓕ CULTIVATEUR DES TRACES

Ⓖ TRACK CULTIVATOR

Ⓡ РЫХЛИТЕЛЬ КОЛЕИ

Ⓟ SPULCHNIARKA STÓP



4013092

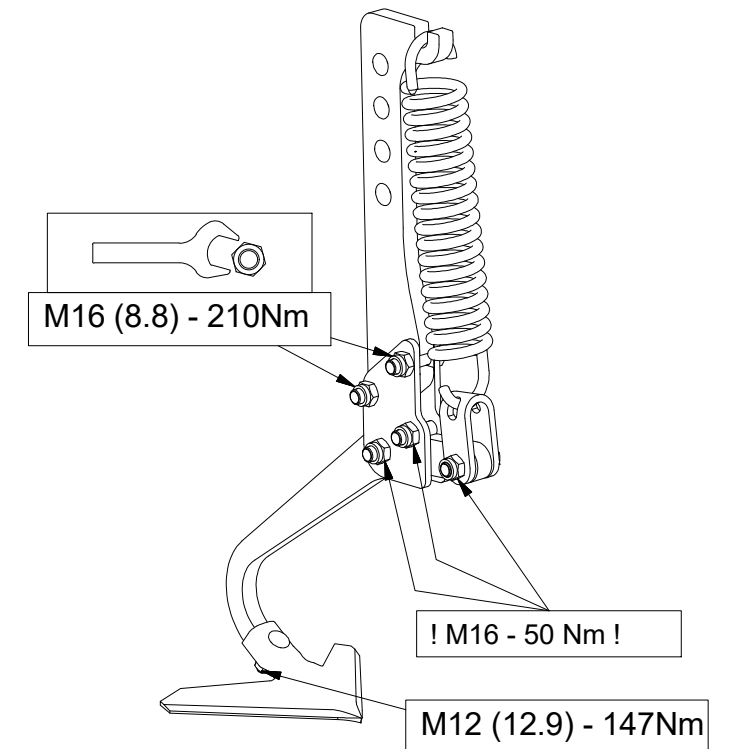
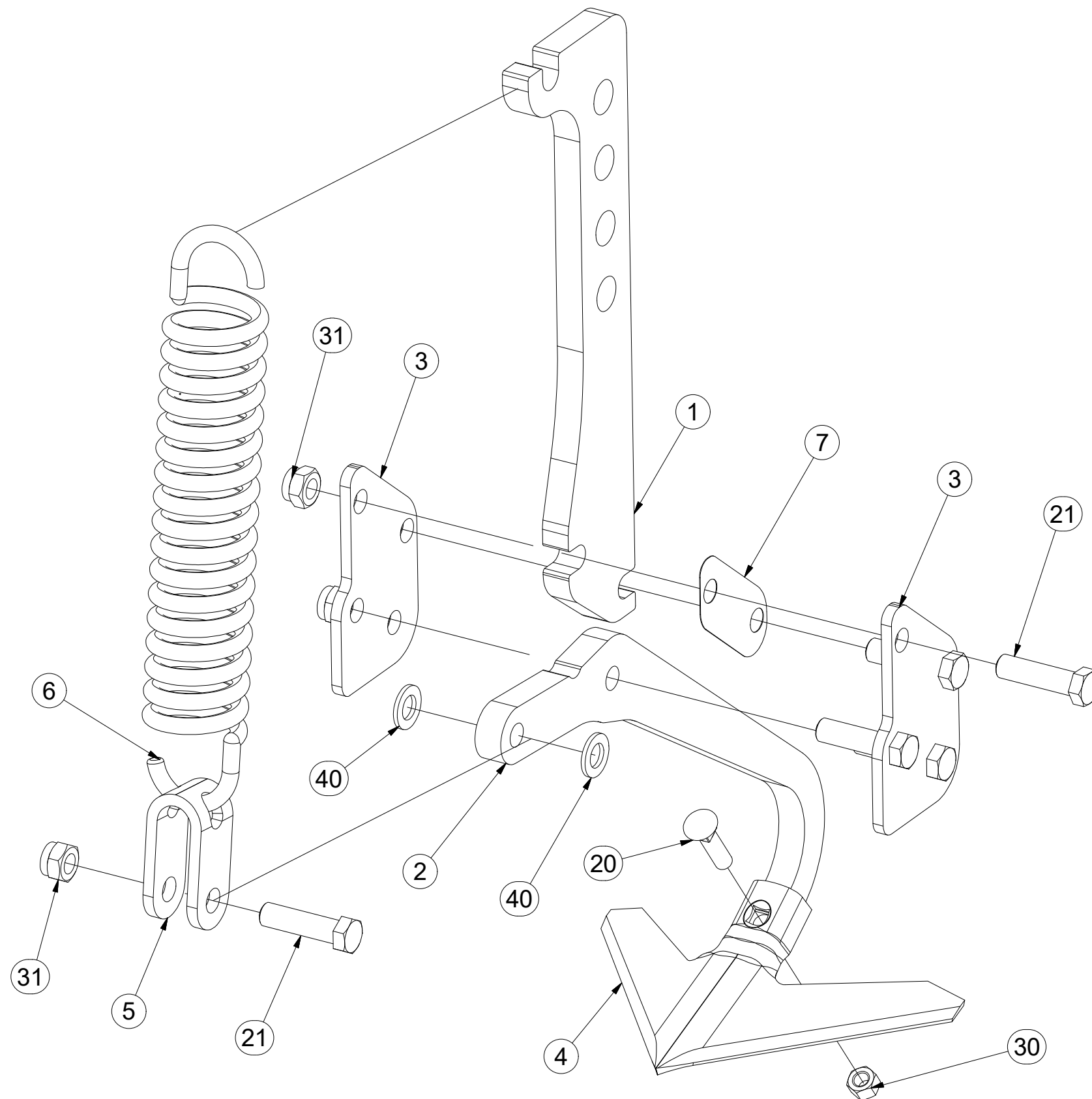

Pos.	Part Number	Pcs.
1	4017307	1
2	4007379	1
3	4005582	2
4	3000236-KOO	1
5	4005445	1
6	m02597	1
7	4005591	1
20	m10440	1
21	m00619	5
30	m10439	1
31	m03683	5
40	m01219	2

ⒸZ SADA PŘEDNÍCH SMYKŮ

Ⓓ SATZ VORDERE ACKERSCHLEPPEN

Ⓕ KIT DE NIVELEURS AVANT

ⒼB SET OF FRONT LEVELLING BARS

ⒺU КОМПЛЕКТ ПЕРЕДНИХ БОРОН

ⒶL ZESTAW PRZEDNICH WŁÓK

Farmet

3006165

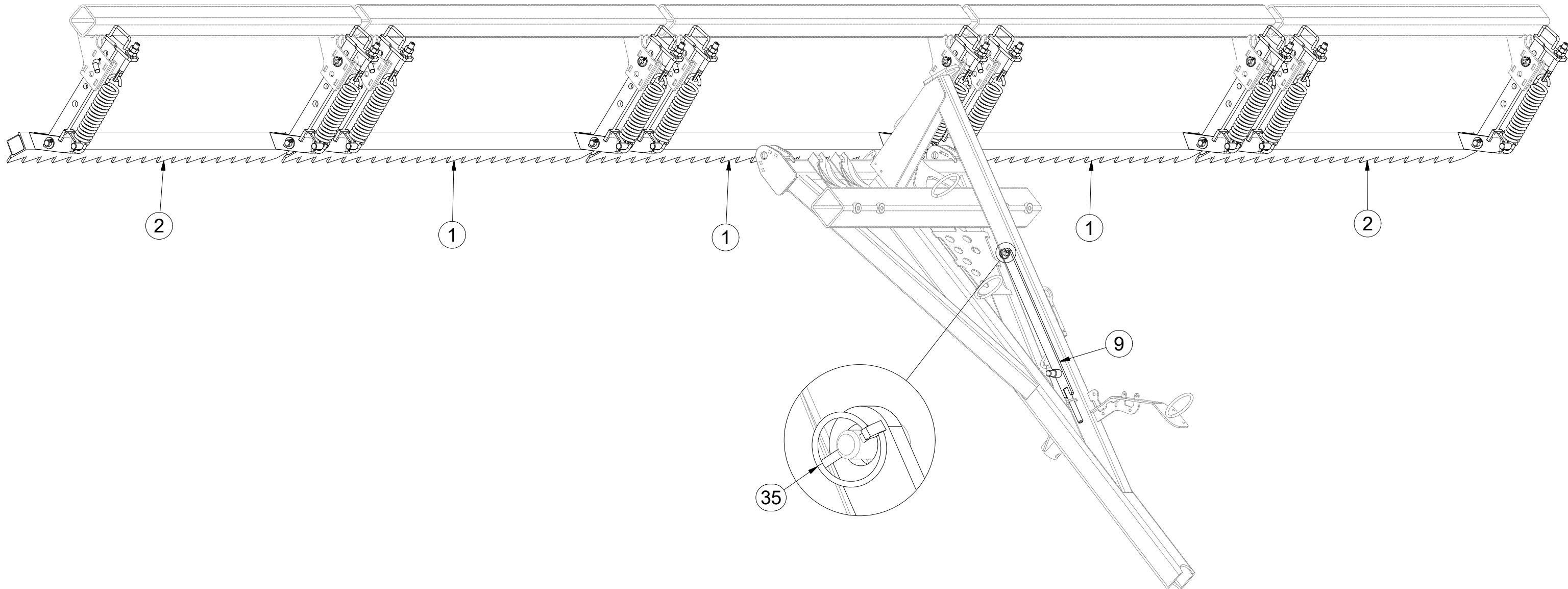

Pos.	Part Number	Pcs.
1	3000312	3
2	3003009	2
9	4006829	1
35	m10454	11

ⒸZ SADA PŘEDNÍCH SMYKŮ

Ⓓ SATZ VORDERE ACKERSCHLEPPEN

Ⓕ KIT DE NIVELEURS AVANT

ⒼB SET OF FRONT LEVELLING BARS

ⒺU КОМПЛЕКТ ПЕРЕДНИХ БОРОН

ⒼL ZESTAW PRZEDNICH WŁÓK



3006165

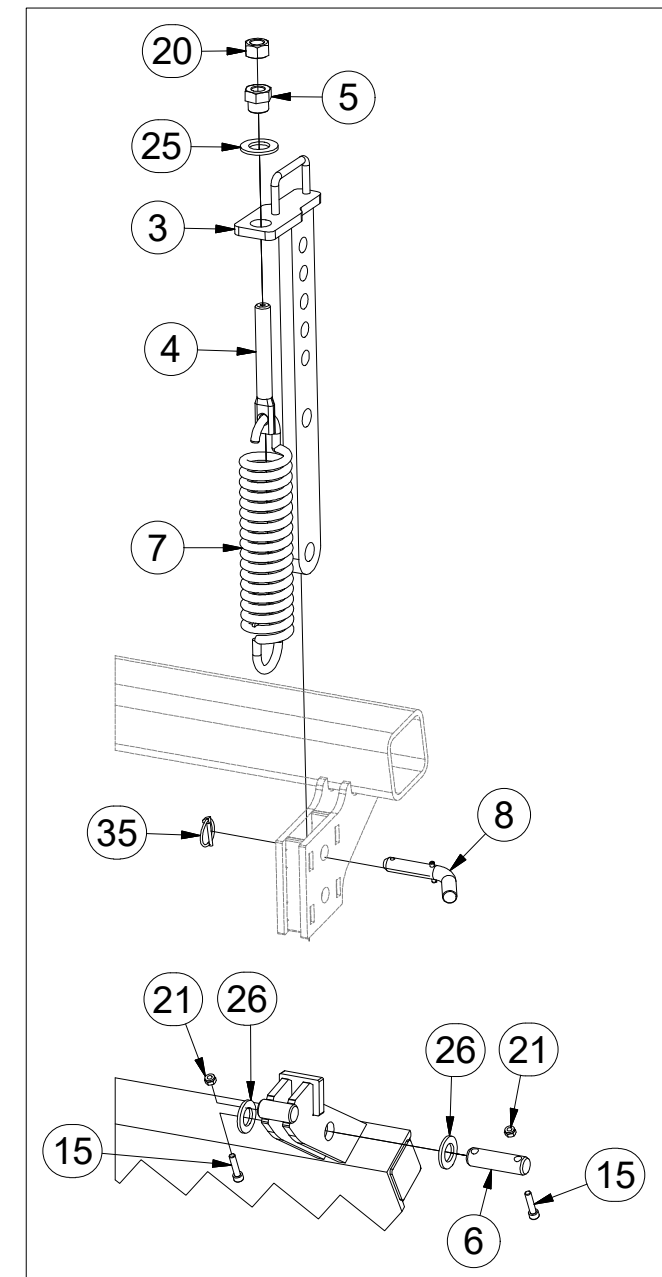
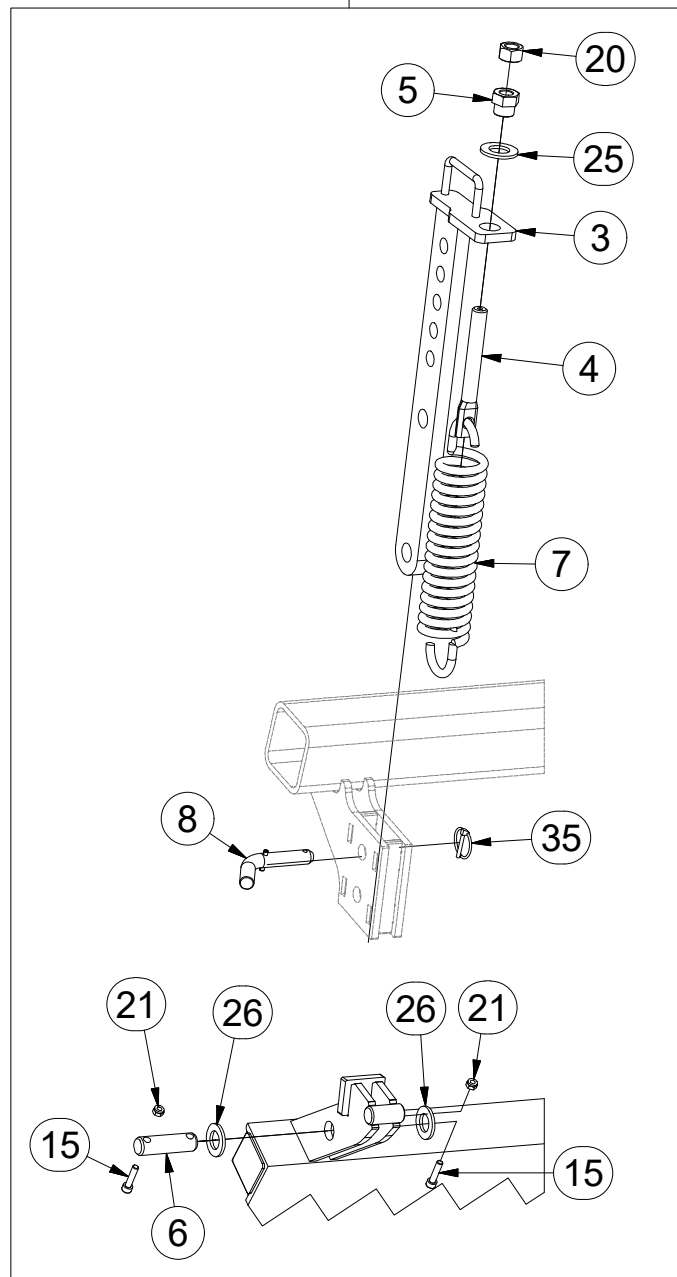
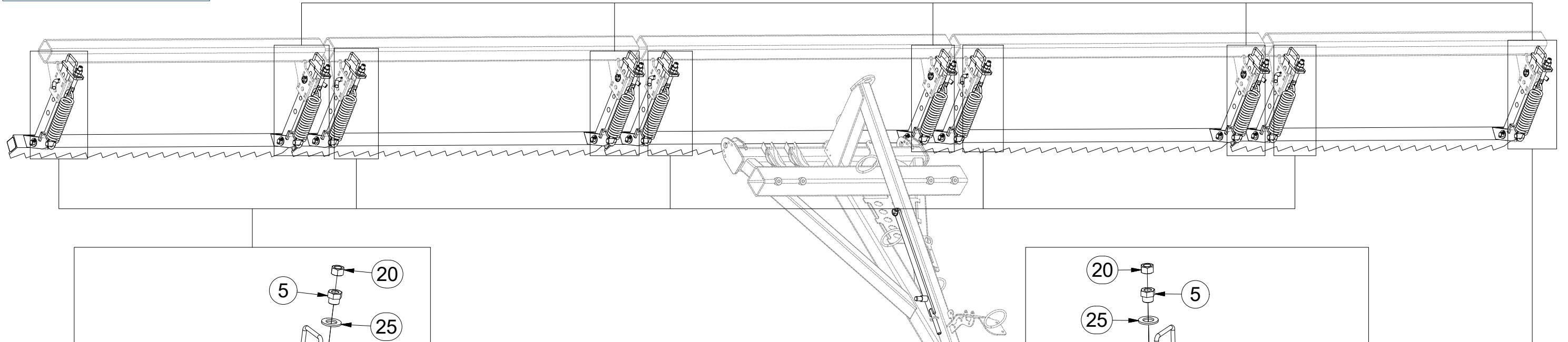

Pos.	Part Number	Pcs.
3	3008686	10
4	4003401	10
5	4000189	10
6	4010390	10
7	m02597	10
8	4012011	10
15	m09464	20
20	m01307	10
21	m04503	20
25	m01225	10
26	m14028	20
35	m10454	11

ⒸZ SADA PŘEDNÍCH VÁLCŮ

Ⓓ SATZ VORDERE WALZEN

Ⓕ KIT DE ROULEAUX AVANT

ⒸB SET OF FRONT ROLLERS

ⒸR КОМПЛЕКТ ПЕРЕДНИХ КАТКОВ

ⒸL ZESTAW PRZEDNICH WAŁÓW



3008669

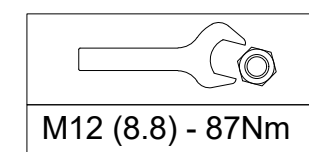
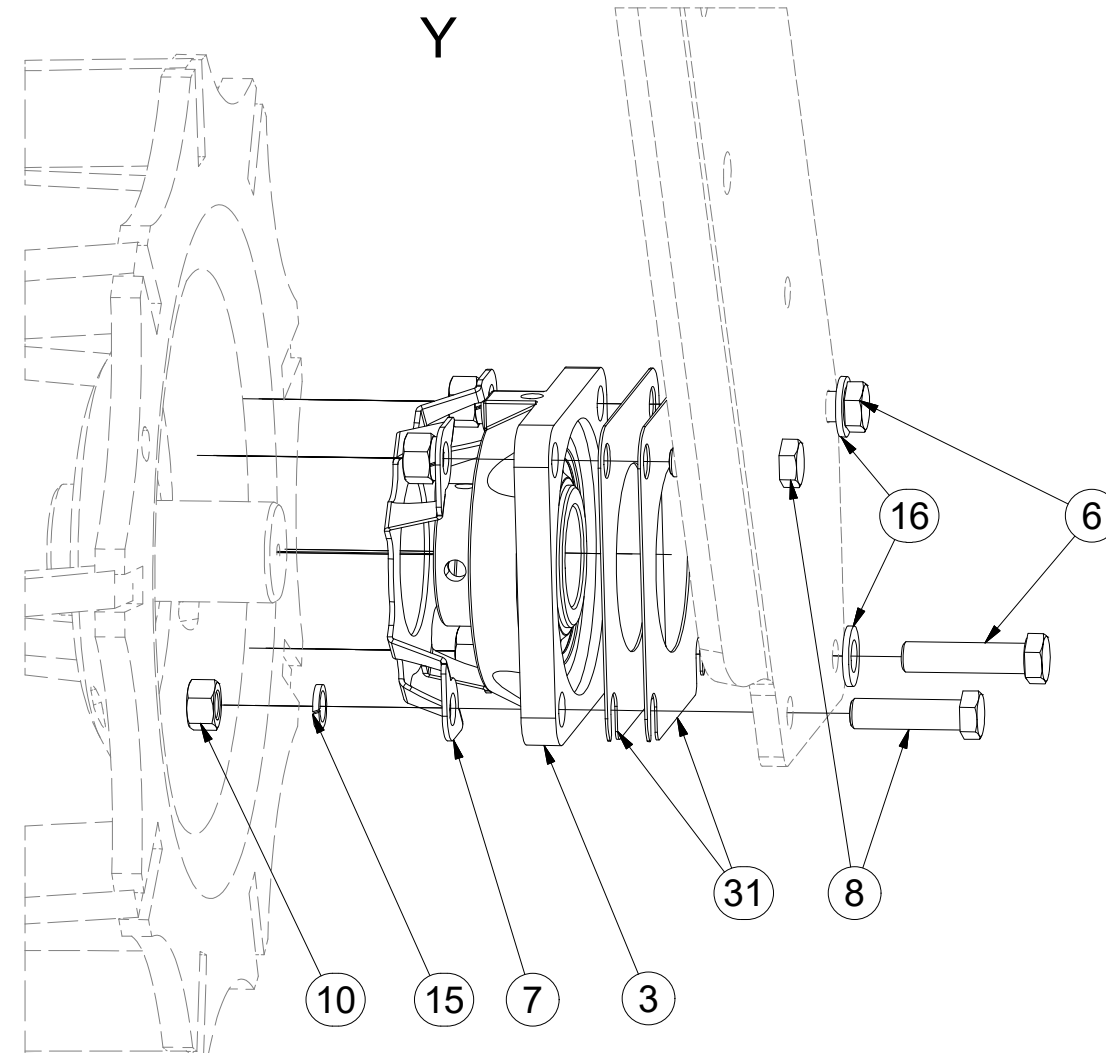
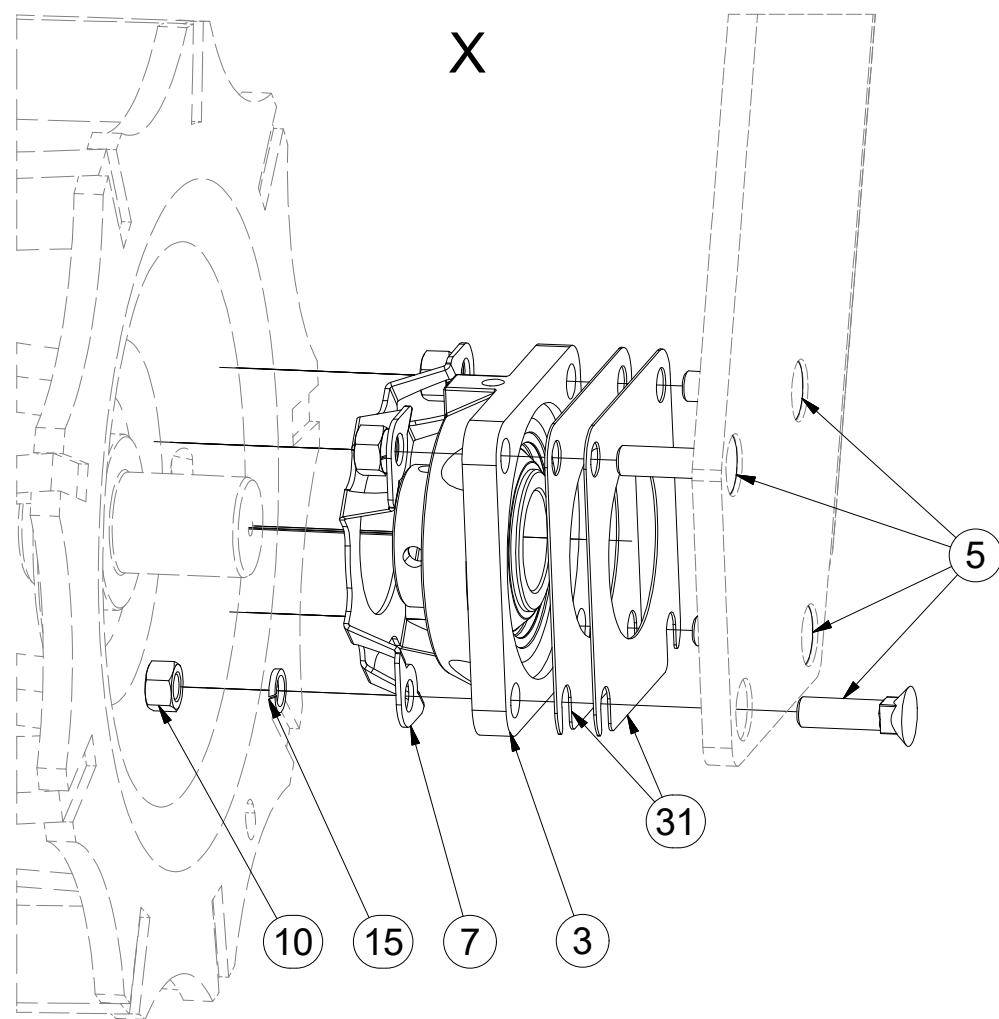
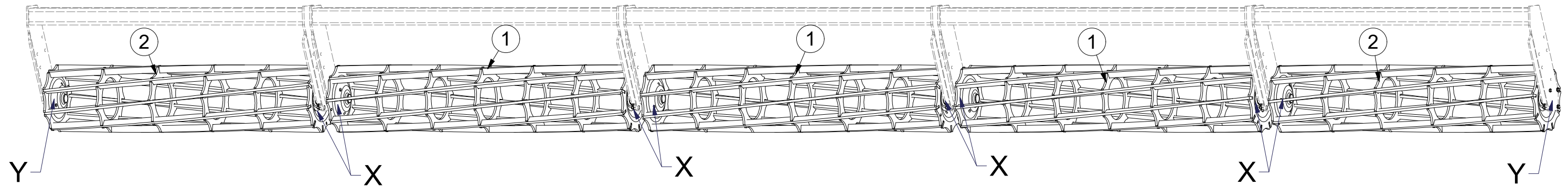

Pos.	Part Number	Pcs.
1	2000539	3
2	2000593	2
3	m15625	10
5	m03519	32
6	m03339	4
7	4014034	10
8	m06077	4
10	m01305	40
15	m03988	40
16	m01214	4
31	4016809	20

- Ⓒ SADA OVLÁDÁNÍ RADLIC
- Ⓓ STEUERSATZ PFLUGSCHAREN
- Ⓕ KIT DE COMMANDE DES SOCS

- Ⓖ SET OF PLOUGHSHARE CONTROL
- Ⓡ КОМПЛЕКТ УПРАВЛЕНИЯ ЛАП
- Ⓟ ZESTAW STEROWANIA RADLICAMI



3006166

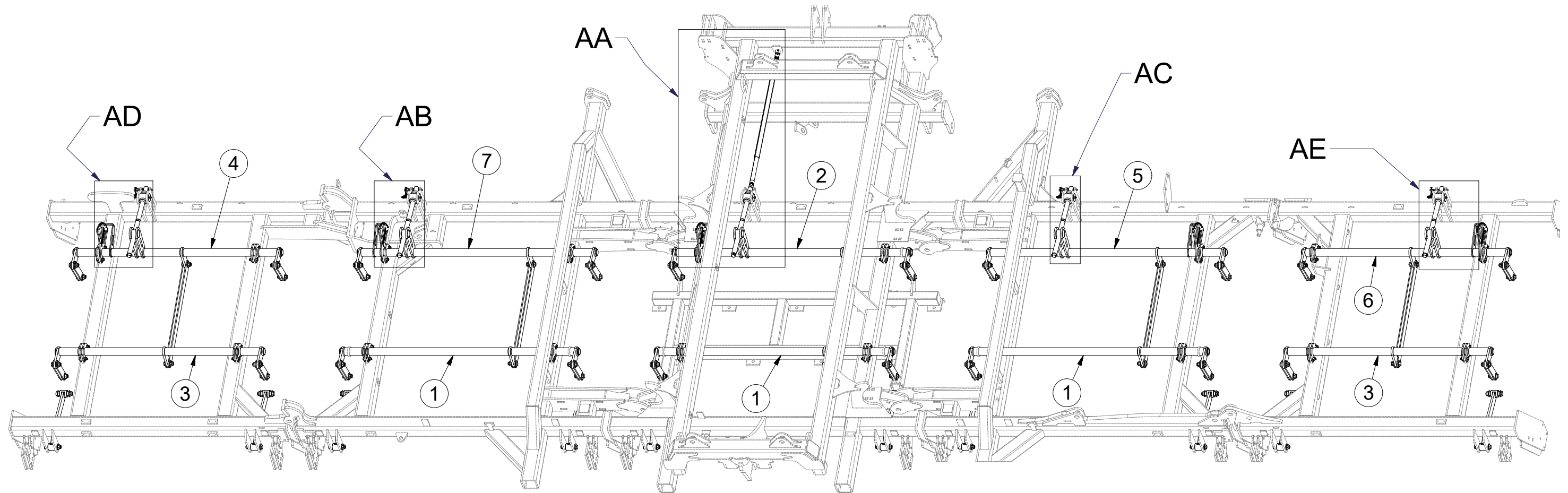

Ⓒ SADA OVLÁDÁNÍ RADLIC

Ⓓ STEUERSATZ PFLUGSCHAREN

Ⓕ KIT DE COMMANDE DES SOCS

Ⓖ SET OF PLOUGHSHARE CONTROL

Ⓡ КОМПЛЕКТ УПРАВЛЕНИЯ ЛАП

Ⓟ ZESTAW STEROWANIA RADLICAMI



3006166

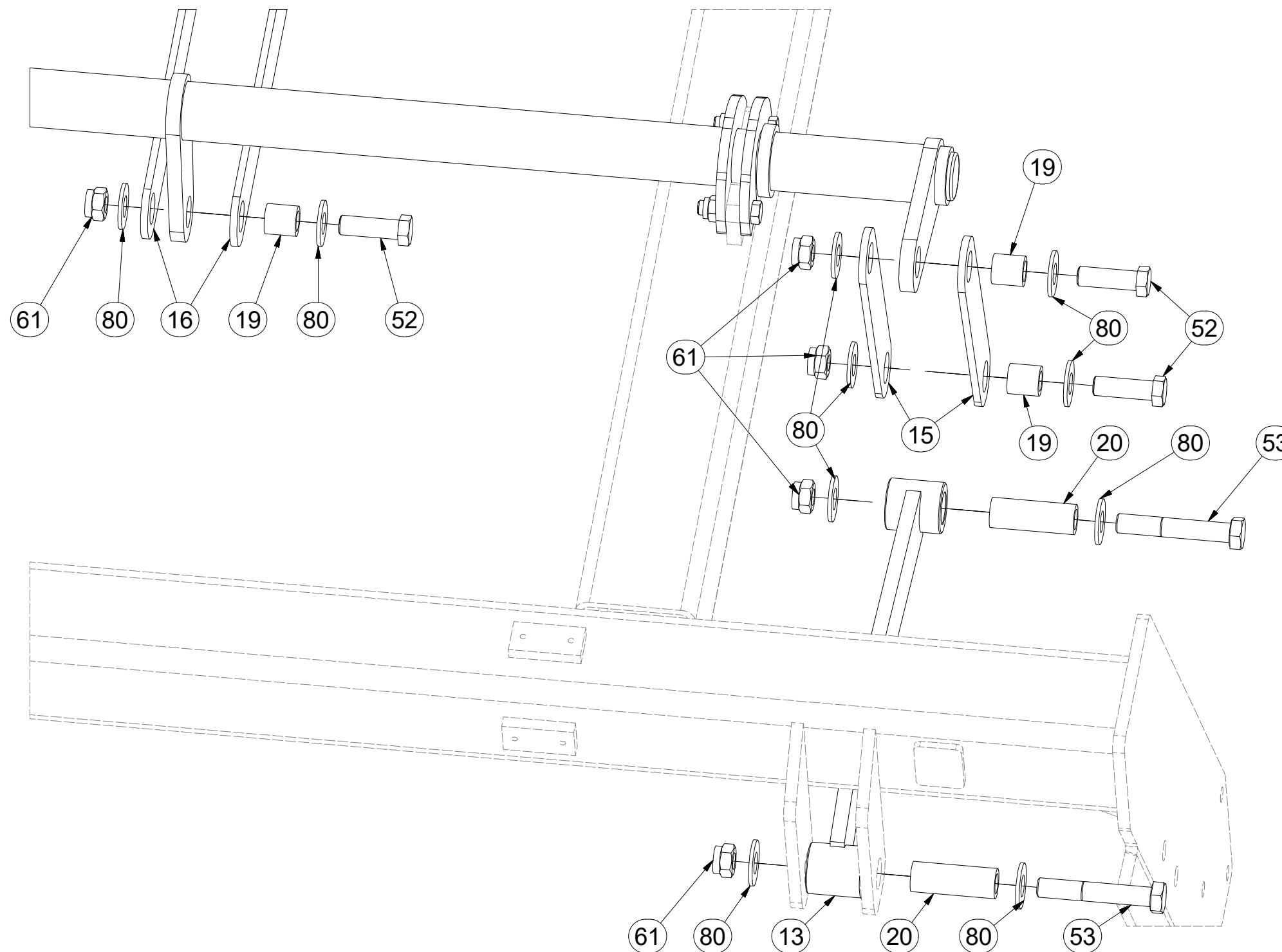

Pos.	Part Number	Pcs.
1	3002830	3
2	3002831	1
3	3003054	2
4	3005286	1
5	3002883	1
6	3005287	1
7	3002884	1
13	8000990-30007	10
15	4005333	40
16	4005334	10
19	4002265	50
20	9001426	20
52	m04355	50
53	m07673	20
61	m03683	70
80	m05651	140

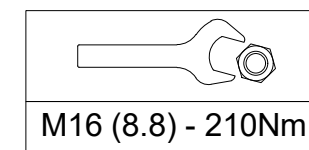

Ⓒ SADA OVLÁDÁNÍ RADLIC

Ⓓ STEUERSATZ PFLUGSCHAREN

Ⓕ KIT DE COMMANDE DES SOCS

Ⓖ SET OF PLOUGHSHARE CONTROL

Ⓡ КОМПЛЕКТ УПРАВЛЕНИЯ ЛАП

Ⓢ ZESTAW STEROWANIA RADLICAMI



3006166

AA

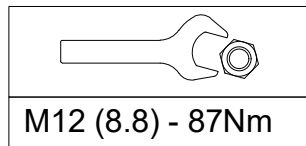
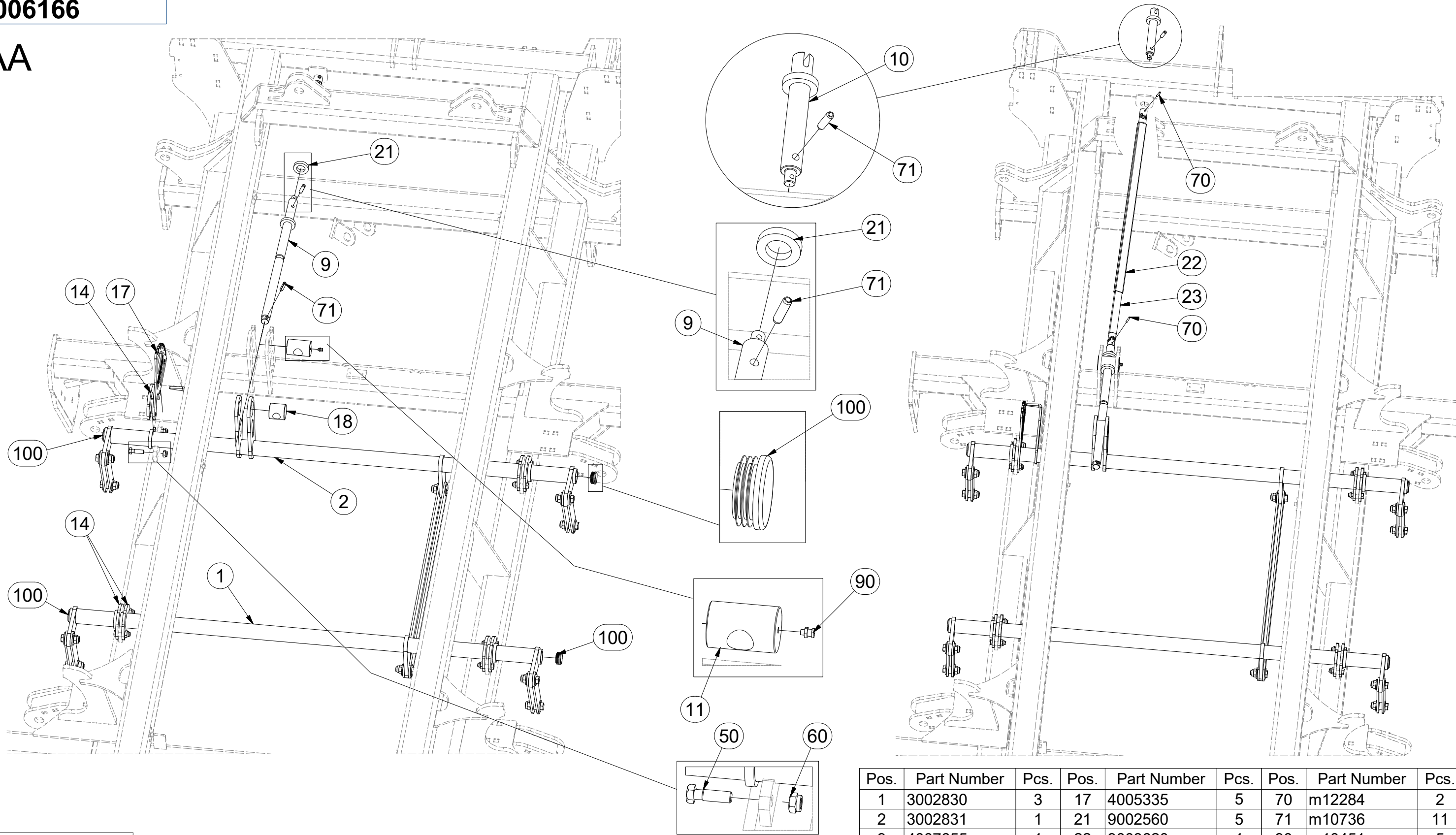

Pos.	Part Number	Pcs.	Pos.	Part Number	Pcs.	Pos.	Part Number	Pcs.
1	3002830	3	17	4005335	5	70	m12284	2
2	3002831	1	21	9002560	5	71	m10736	11
9	4007655	1	22	9003620	1	90	m10451	5
10	4007660	1	23	m05173	1	100	m10130	20
11	9002114	1	50	m03926	12			
14	4005332	35	60	m04301	40			

CZ SADA OVLÁDÁNÍ RADLIC
 D STEUERSATZ PFLUGSCHAREN
 F KIT DE COMMANDE DES SOCS

GB SET OF PLOUGHSHARE CONTROL
 RU КОМПЛЕКТ УПРАВЛЕНИЯ ЛАП
 PL ZESTAW STEROWANIA RADLICAMI



3006166

AB - 2 M

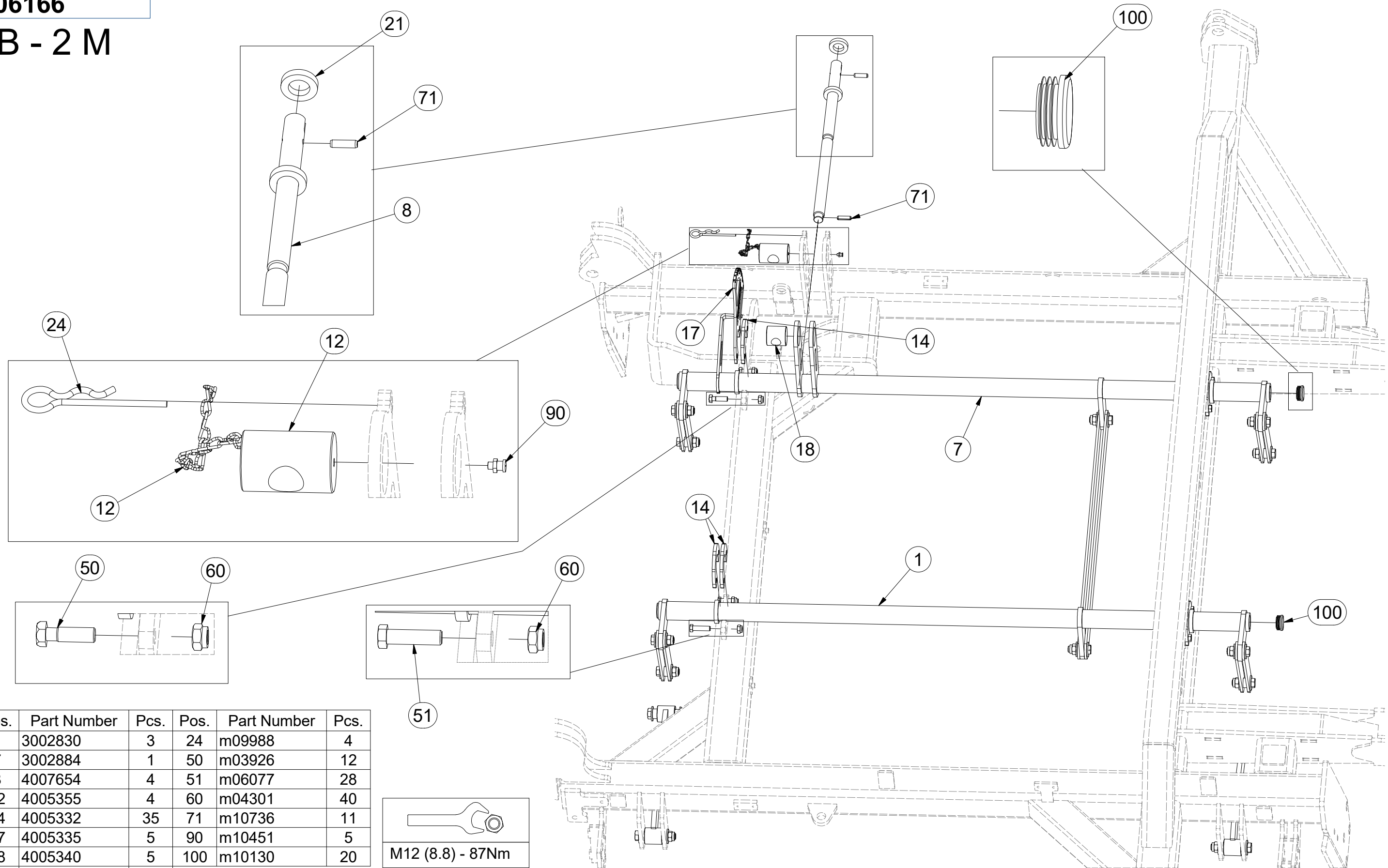

Pos.	Part Number	Pcs.	Pos.	Part Number	Pcs.
1	3002830	3	24	m09988	4
7	3002884	1	50	m03926	12
8	4007654	4	51	m06077	28
12	4005355	4	60	m04301	40
14	4005332	35	71	m10736	11
17	4005335	5	90	m10451	5
18	4005340	5	100	m10130	20
21	9002560	5			

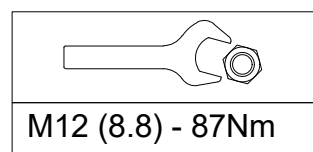

CZ SADA OVLÁDÁNÍ RADLIC
 D STEUERSATZ PFLUGSCHAREN
 F KIT DE COMMANDE DES SOCS

GB SET OF PLOUGHSHARE CONTROL
 RU КОМПЛЕКТ УПРАВЛЕНИЯ ЛАП
 PL ZESTAW STEROWANIA RADLICAMI



3006166

AC - 2 M

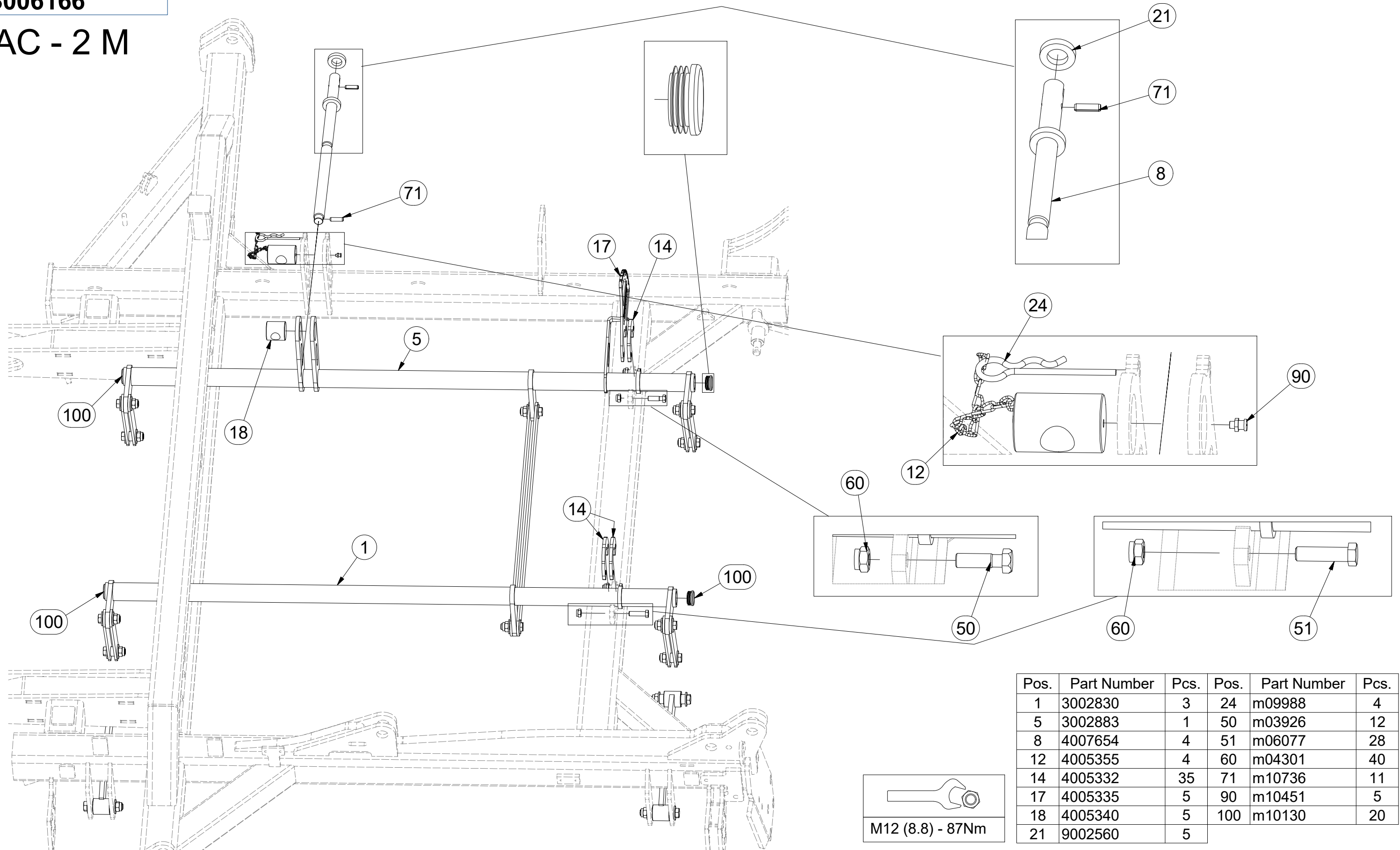

 M12 (8.8) - 87Nm

Pos.	Part Number	Pcs.	Pos.	Part Number	Pcs.
1	3002830	3	24	m09988	4
5	3002883	1	50	m03926	12
8	4007654	4	51	m06077	28
12	4005355	4	60	m04301	40
14	4005332	35	71	m10736	11
17	4005335	5	90	m10451	5
18	4005340	5	100	m10130	20
21	9002560	5			

Ⓒ SADA OVLÁDÁNÍ RADLIC

Ⓓ STEUERSATZ PFLUGSCHAREN

Ⓕ KIT DE COMMANDE DES SOCS

Ⓖ SET OF PLOUGHSHARE CONTROL

Ⓡ КОМПЛЕКТ УПРАВЛЕНИЯ ЛАП

Ⓢ ZESTAW STEROWANIA RADLICAMI



3006166

AD - 1,8 M

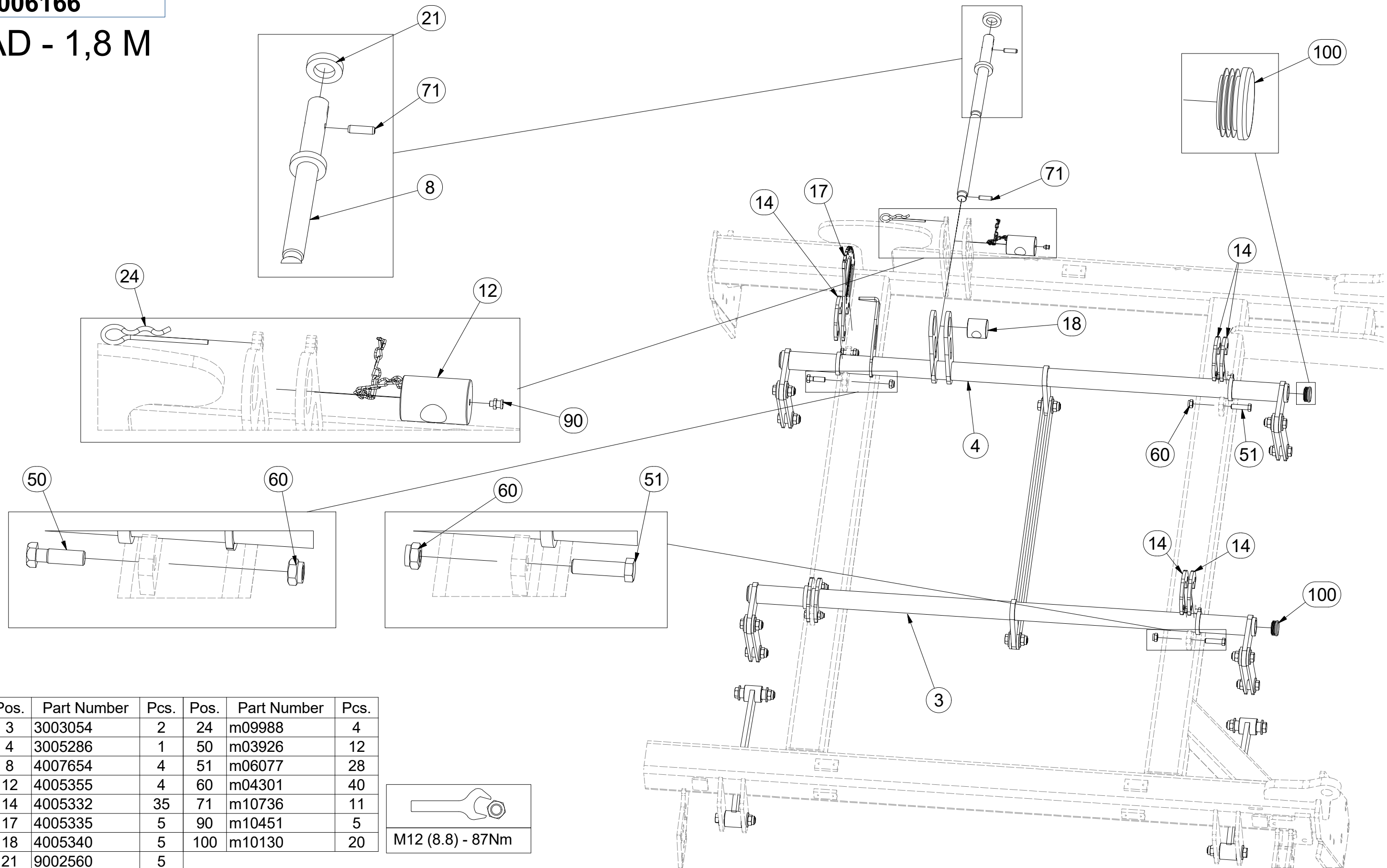

Pos.	Part Number	Pcs.	Pos.	Part Number	Pcs.
3	3003054	2	24	m09988	4
4	3005286	1	50	m03926	12
8	4007654	4	51	m06077	28
12	4005355	4	60	m04301	40
14	4005332	35	71	m10736	11
17	4005335	5	90	m10451	5
18	4005340	5	100	m10130	20
21	9002560	5			

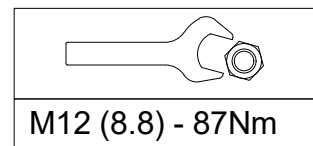

CZ SADA OVLÁDÁNÍ RADLIC
 D STEUERSATZ PFLUGSCHAREN
 F KIT DE COMMANDE DES SOCS

GB SET OF PLOUGHSHARE CONTROL
 RU КОМПЛЕКТ УПРАВЛЕНИЯ ЛАП
 PL ZESTAW STEROWANIA RADLICAMI



3006166

AE - 1,8 M

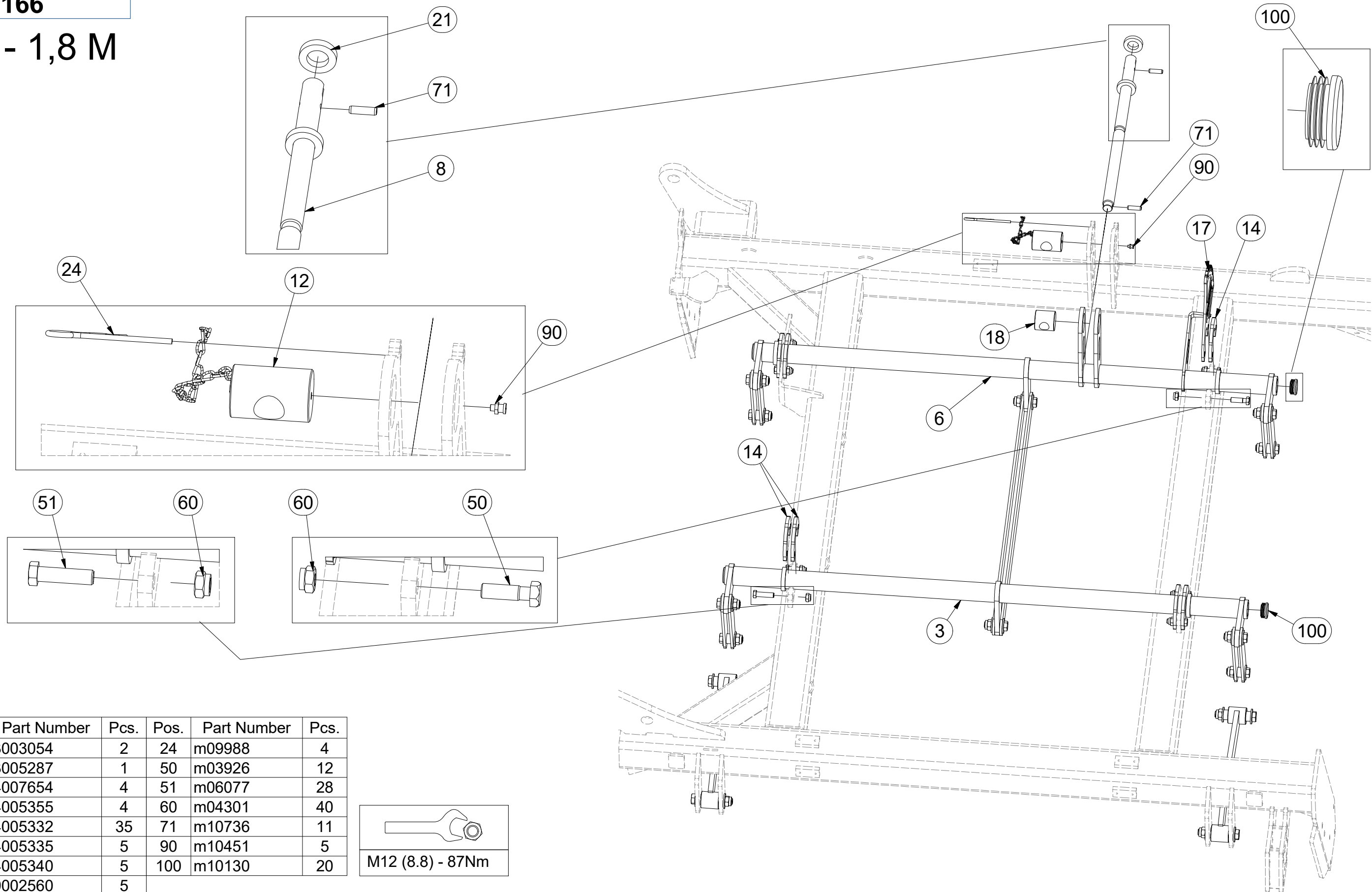

Pos.	Part Number	Pcs.	Pos.	Part Number	Pcs.
3	3003054	2	24	m09988	4
6	3005287	1	50	m03926	12
8	4007654	4	51	m06077	28
12	4005355	4	60	m04301	40
14	4005332	35	71	m10736	11
17	4005335	5	90	m10451	5
18	4005340	5	100	m10130	20
21	9002560	5			

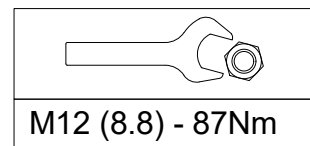

M12 (8.8) - 87Nm

ⒸZ SADA RADLIC

Ⓓ SCHARSATZ

Ⓕ KIT DE SOCS

ⒸB SET OF PLOUGHSHARES

ⒸU КОМПЛЕКТ ЛАП

ⒸL ZESTAW REDLIC



3005051

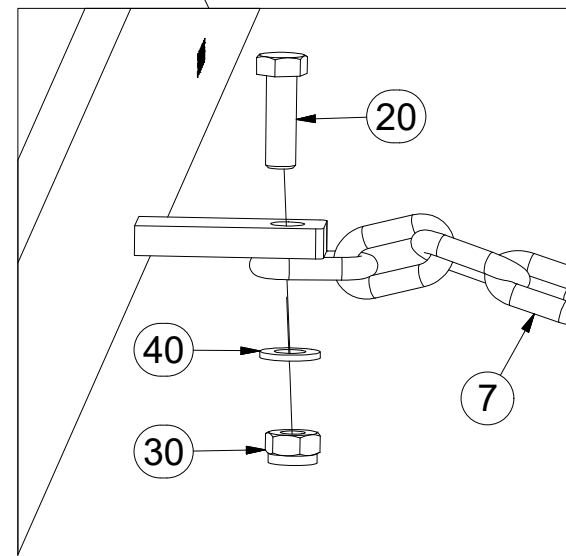
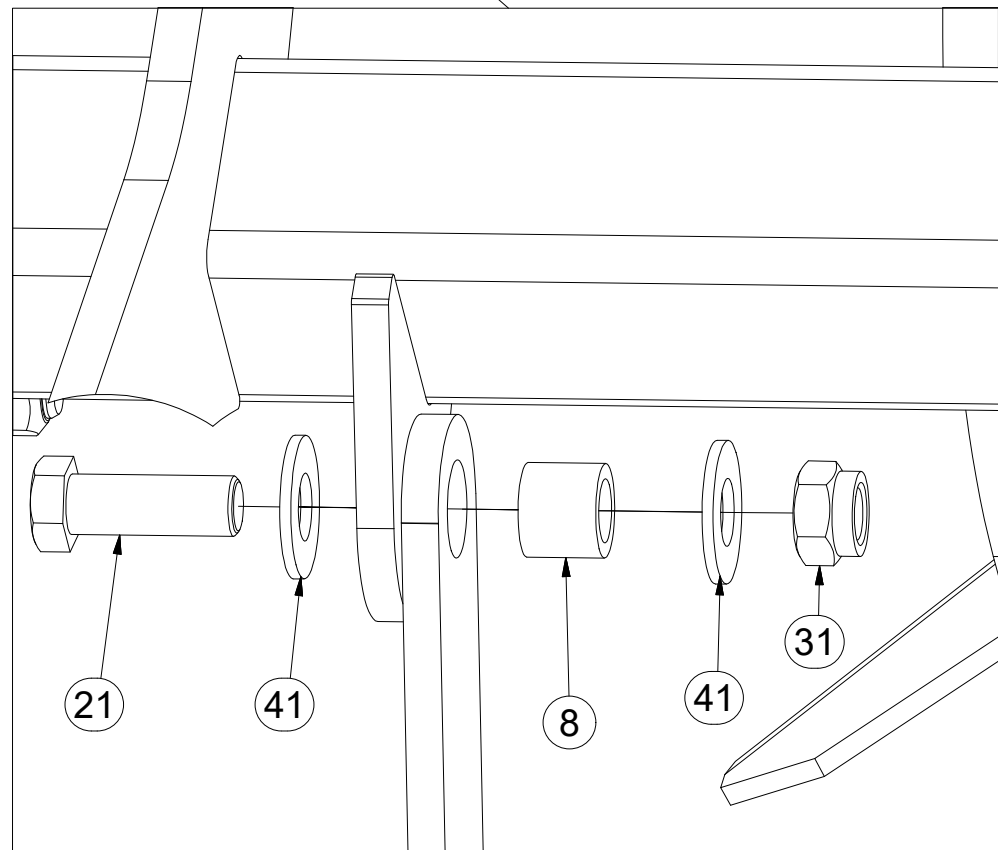
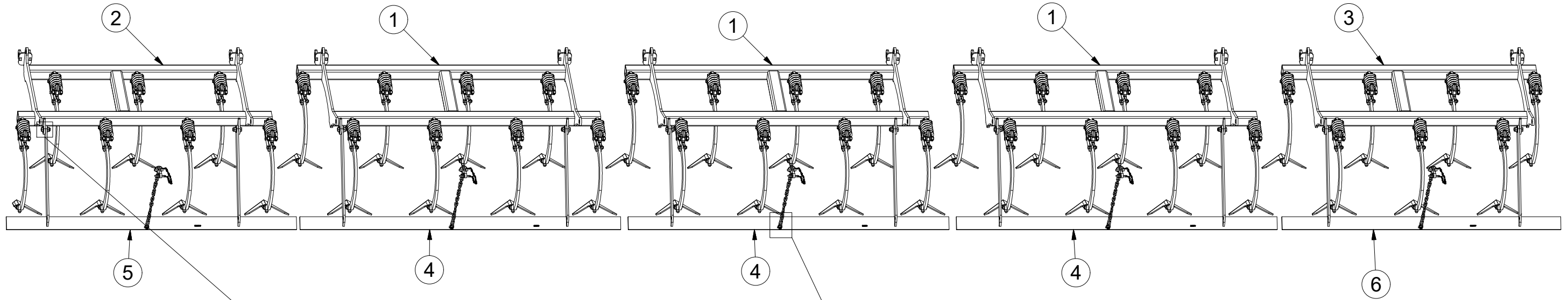

Pos.	Part Number	Pcs.
1	3005054	3
2	3005314	1
3	3005315	1
4	3005572	3
5	3005376	1
6	3005377	1
7	4001641	5
8	4004451	10
20	m01092	5
21	m02254	10
30	m04503	5
31	m03683	10
40	m01203	5
41	m05651	20

Ⓒ SADA RADLIC

Ⓓ SCHARSATZ

Ⓕ KIT DE SOCS

3005054

Ⓖ SET OF PLOUGHSHARES

Ⓡ КОМПЛЕКТ ЛАП

Ⓟ ZESTAW REDLIC

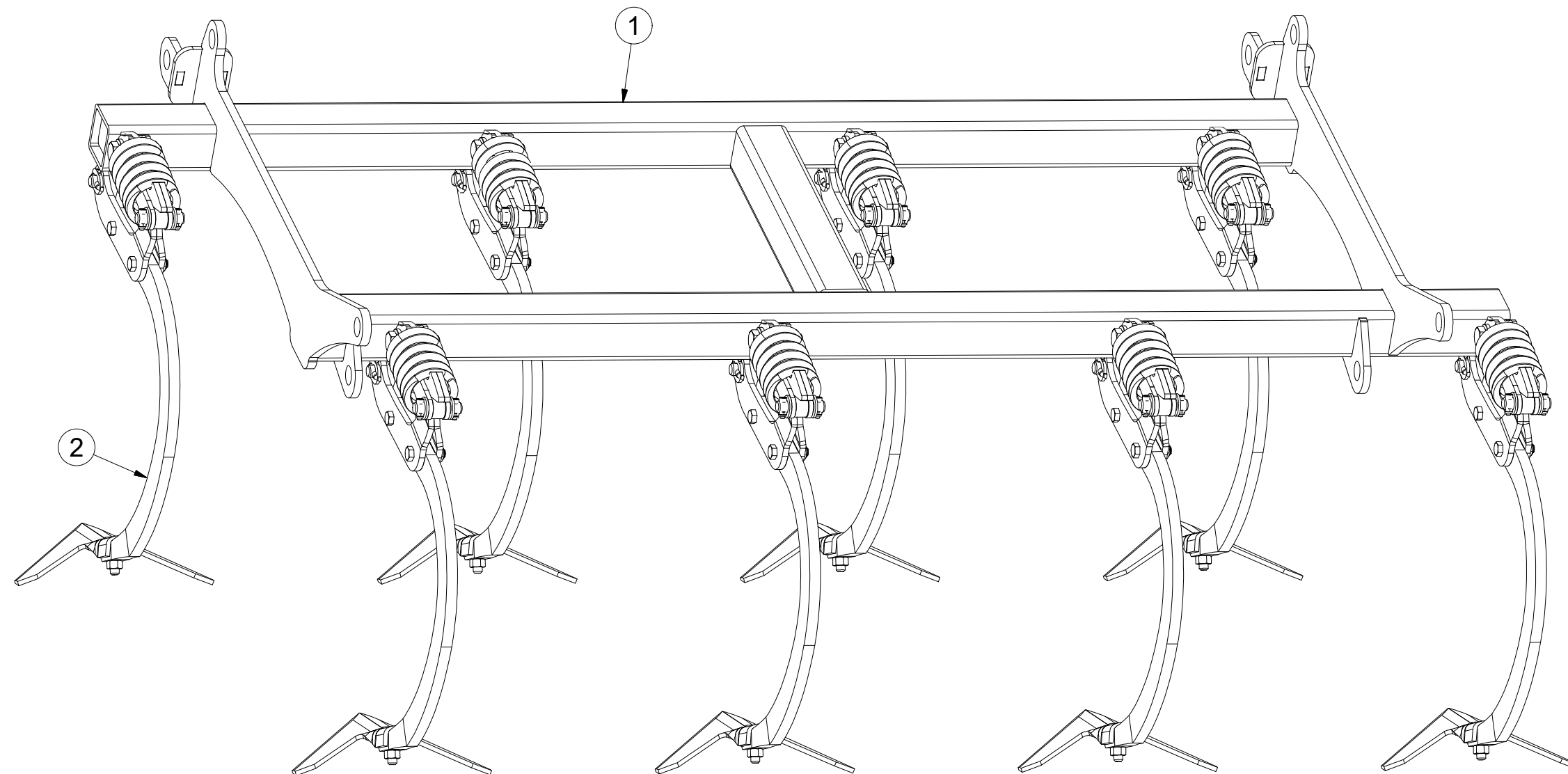
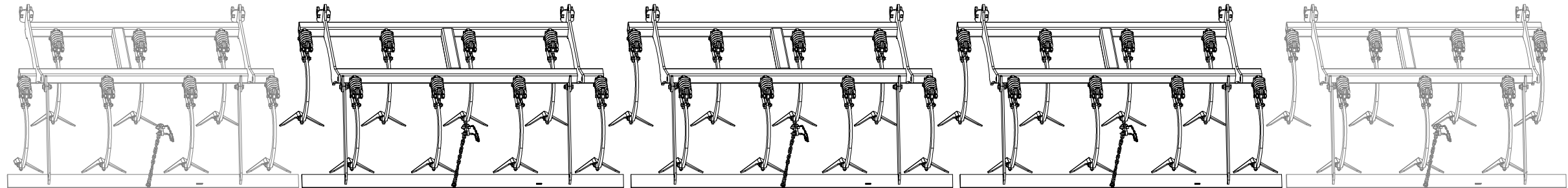

Pos.	Part Number	Pcs.
1	3005055	1
2	4009708_2	8

Ⓒ SADA RADLIC

Ⓓ SCHARSATZ

Ⓕ KIT DE SOCS

Ⓖ SET OF PLOUGHSHARES

Ⓡ КОМПЛЕКТ ЛАП

Ⓟ ZESTAW REDLIC



3005314

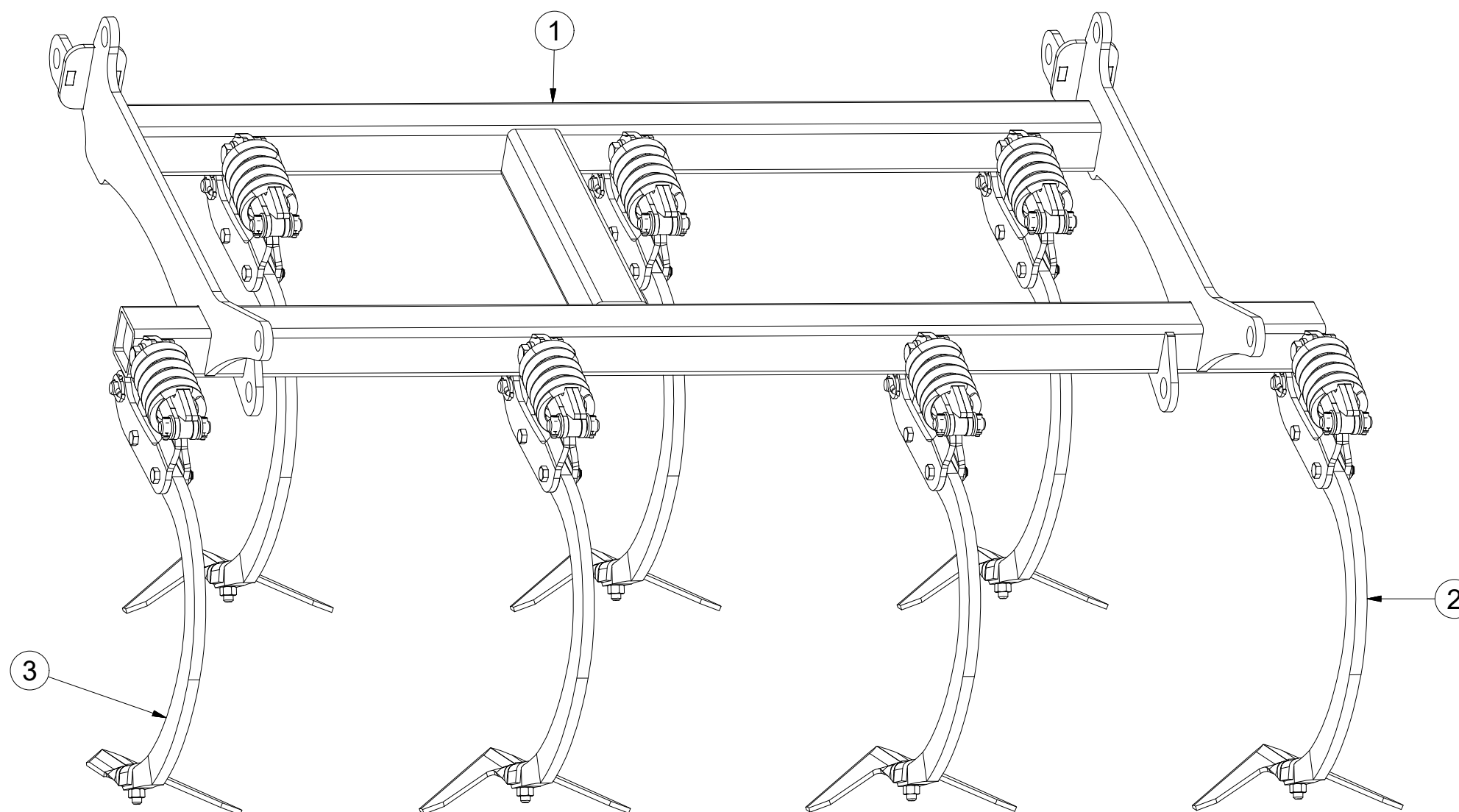
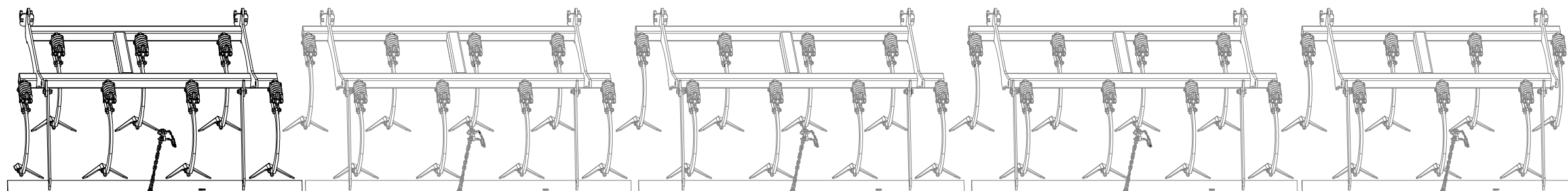

Pos.	Part Number	Pcs.
1	3005316	1
2	4009708_2	6
3	4014549	1

Ⓒ SADA RADLIC

Ⓓ SCHARSATZ

Ⓕ KIT DE SOCS

3005315

Ⓖ SET OF PLOUGHSHARES

Ⓡ КОМПЛЕКТ ЛАП

Ⓟ ZESTAW REDLIC

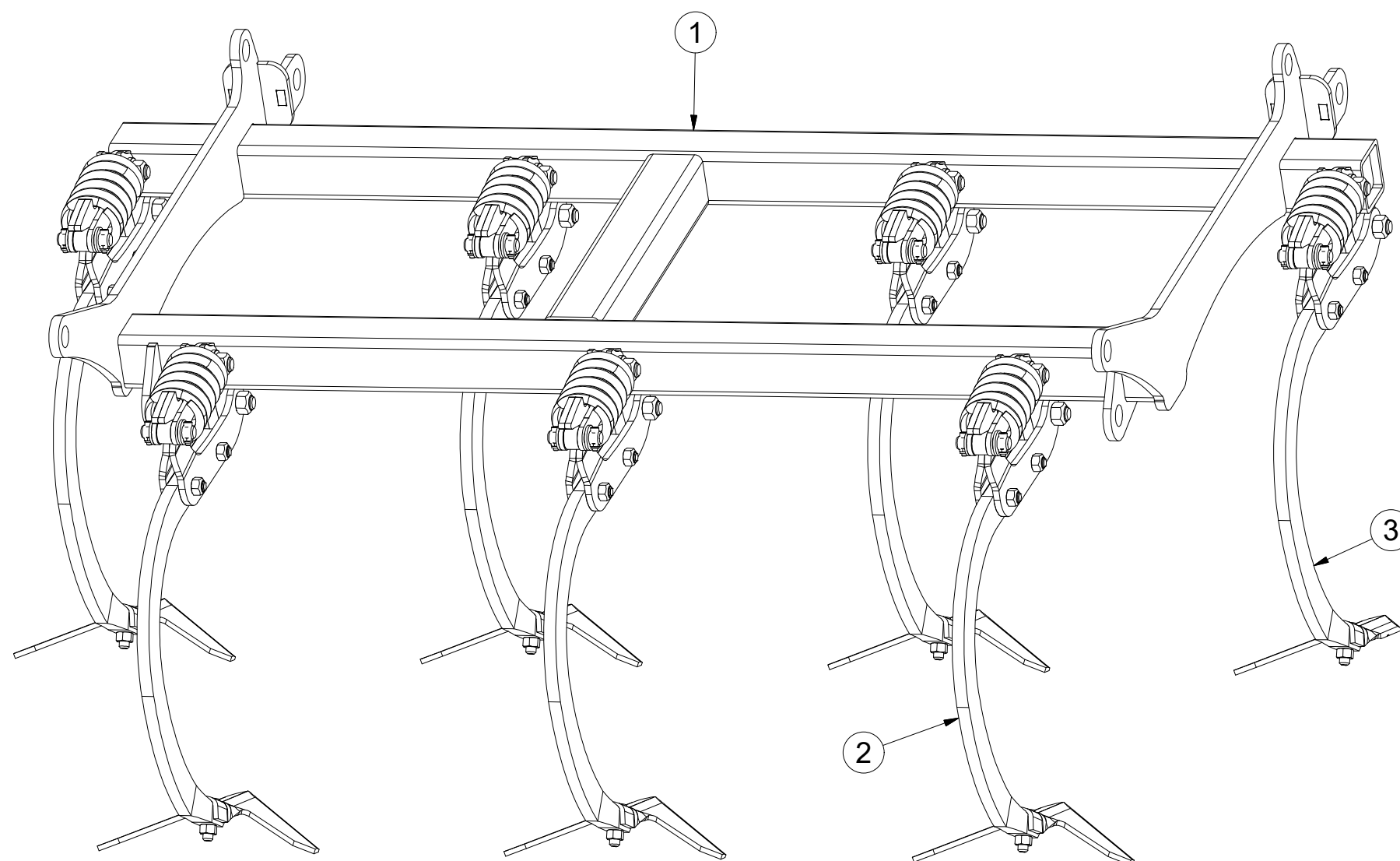
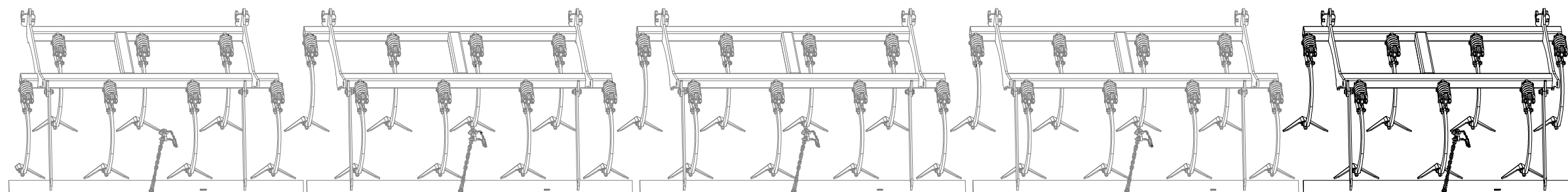

Pos.	Part Number	Pcs.
1	3005317	1
2	4009708_2	6
3	4014550	1

Ⓒ RADLICE KRAJOVÁ / LEVÁ

Ⓓ RANDPFLUGSCHAR / LINKS

Ⓕ SOC D'EXTRÉMITÉ DE LA /GAUCHE

4014549

Ⓖ PLOUGHSHARE EDGE / LEFT

Ⓔ БОКОВАЯ ЛАПА / ЛЕВАЯ

Ⓗ REDLICA SKRAJNA / LEWA

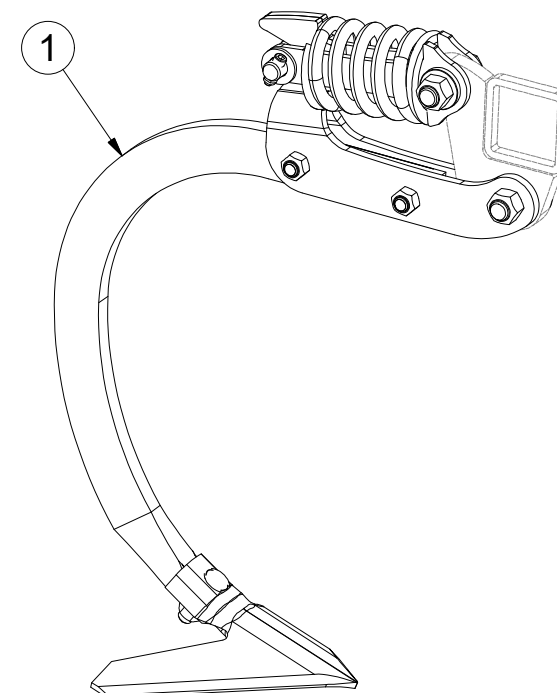
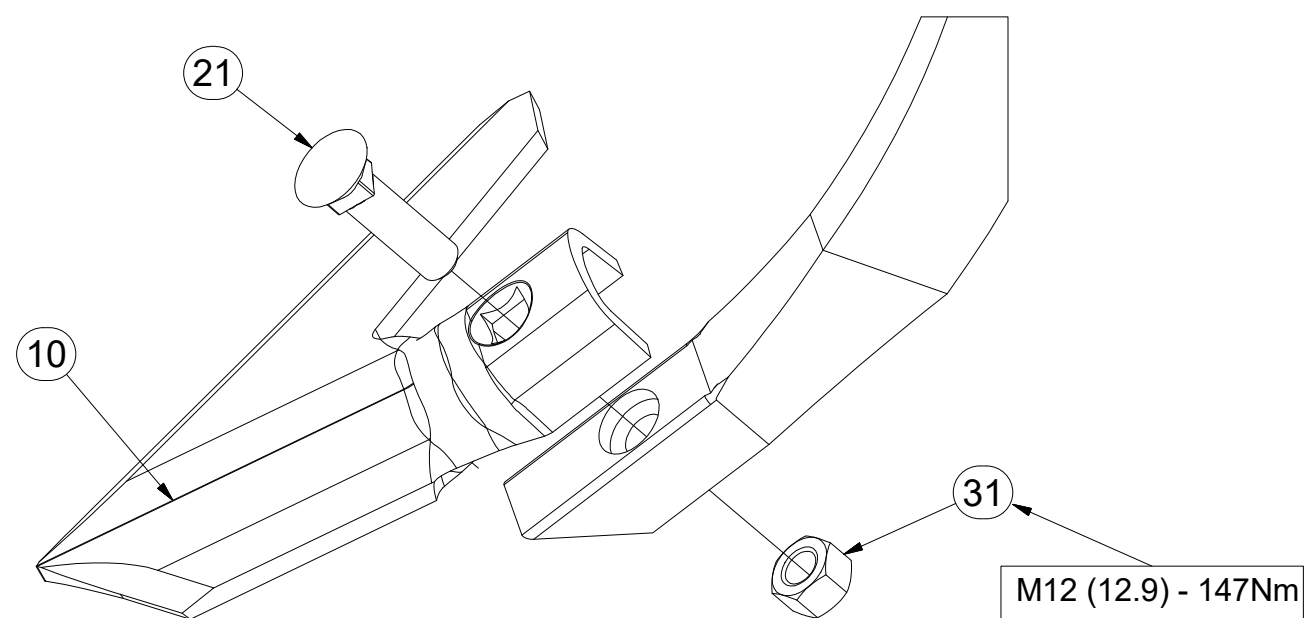
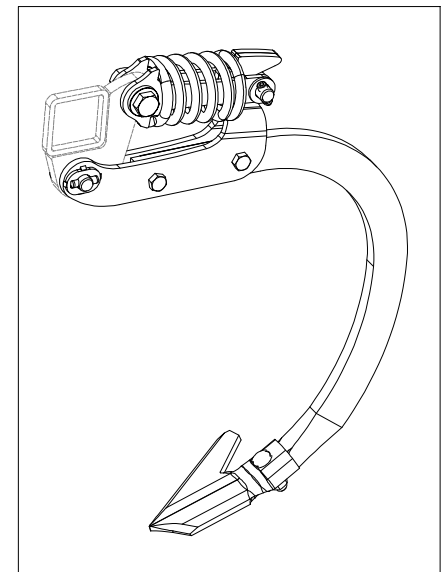
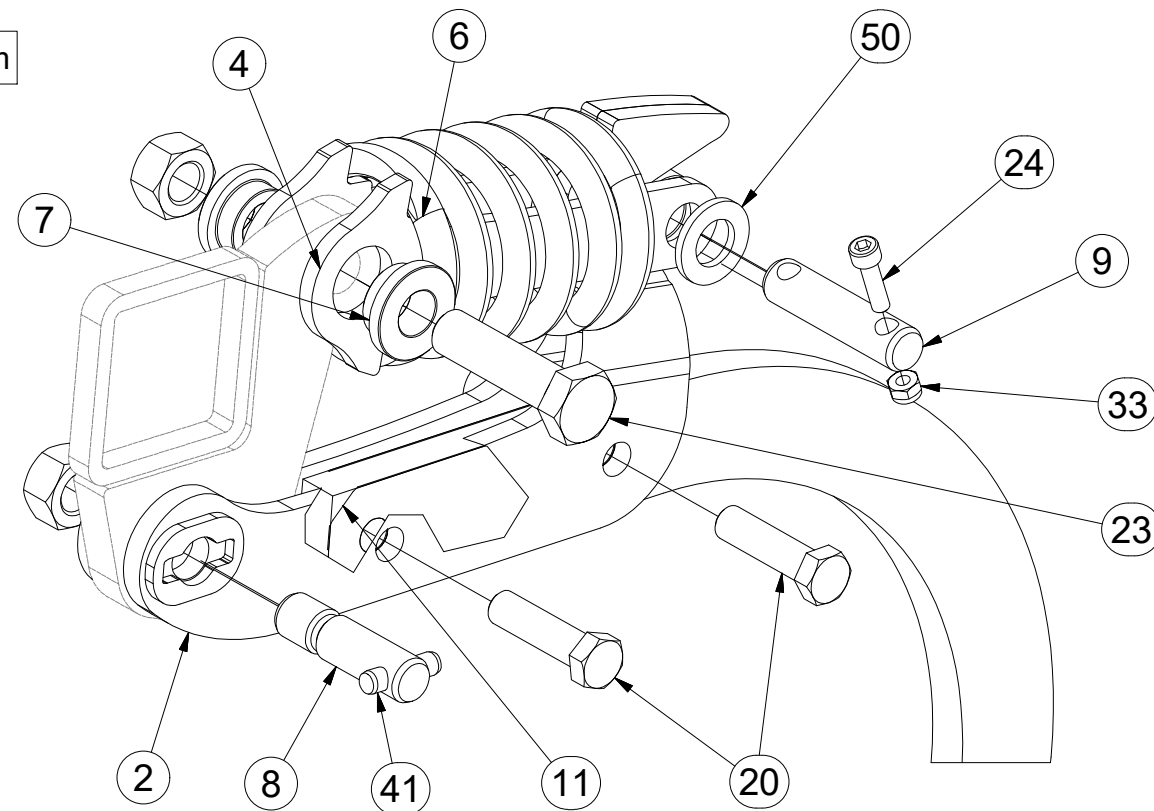
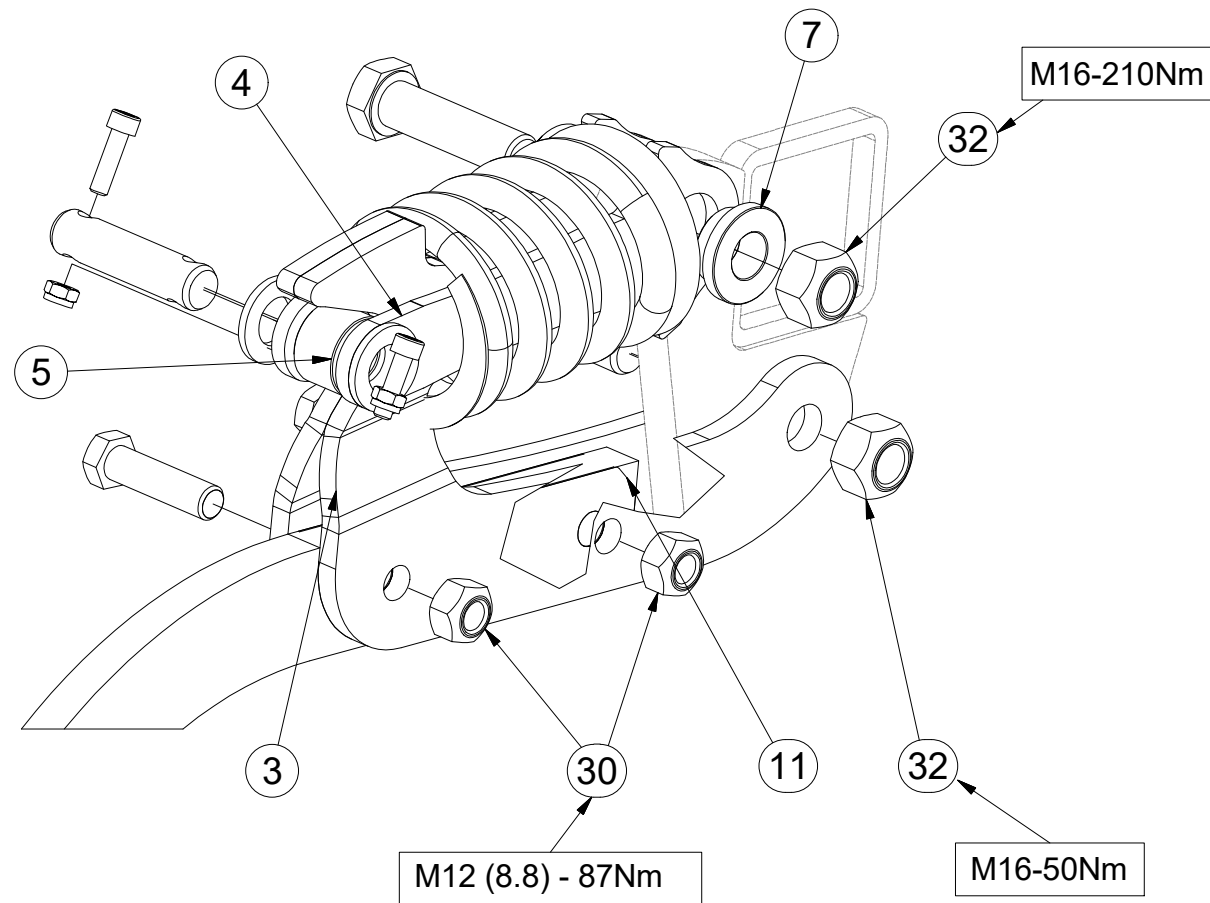

Pos.	Part Number	Pcs.
1	9003266	1
2	4009710	1
3	3005057	1
4	4014253	2
5	4009624	1
6	m12950	1
7	4014252	2
8	4009647	1
9	4015783	1
10	4007280	1
11	4014863	2
20	m06077	2
21	m10440	1
23	m14482	1
24	m15215	2
30	m06233	2
31	m10439	1
32	m12150	2
33	m05560	2
41	m12464	1
50	m14971	2

CZ RADLICE KRAJOVÁ / PRAVÁ
 D RANDPFLUGSCHAR / RECHTS
 F SOC D'EXTRÉMITÉ DE LA / DROITE

GB PLOUGHSHARE EDGE / RIGHT
 RU БОКОВАЯ ЛАПА / ПРАВАЯ
 PL REDLICA SKRAJNA / PRAWA



4014550

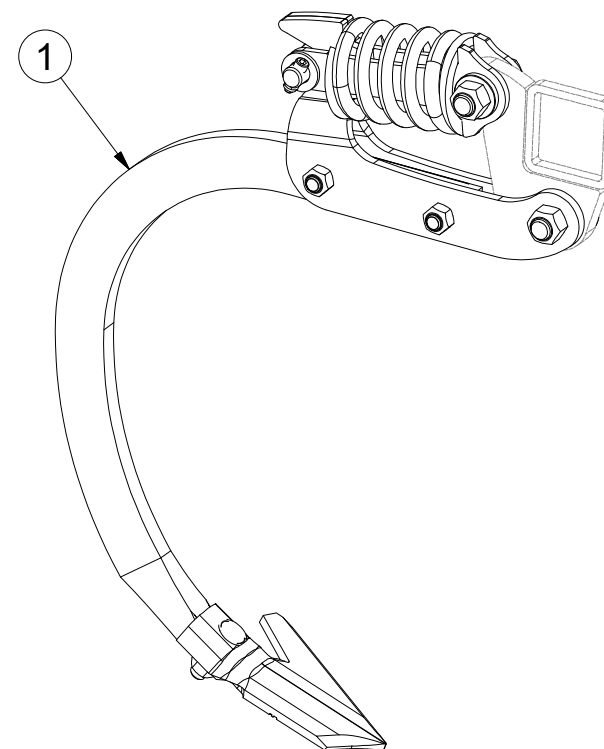
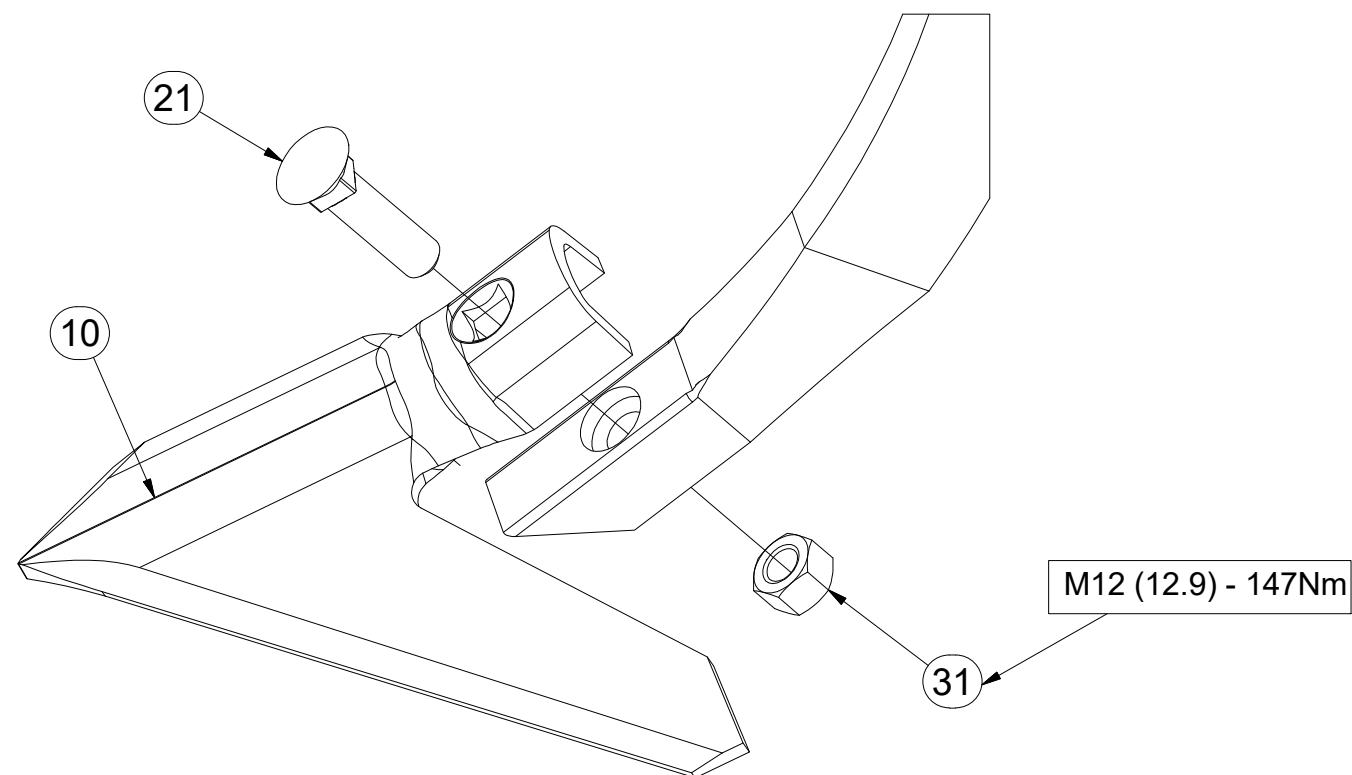
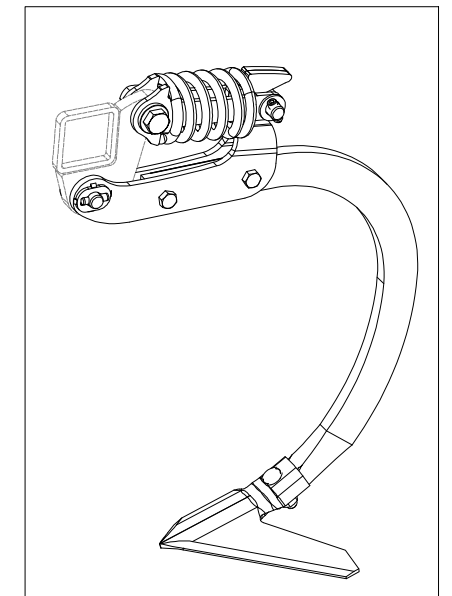
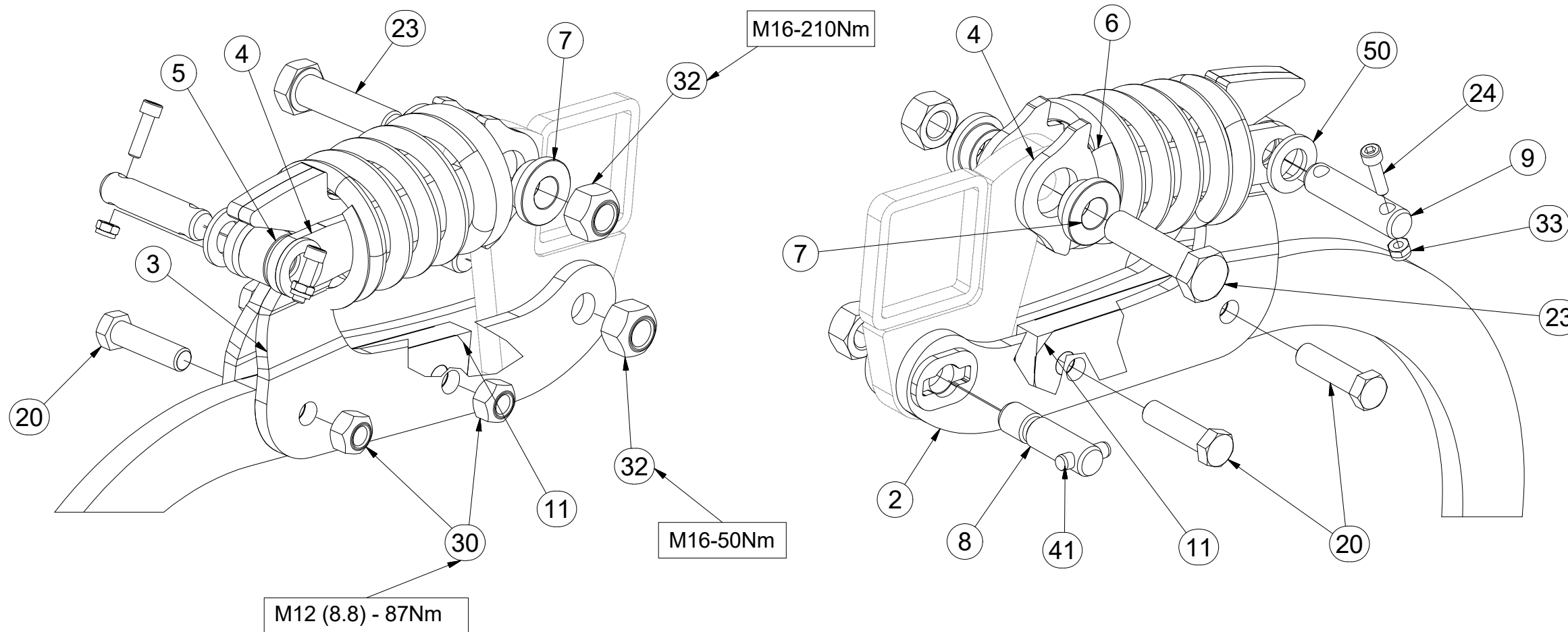

Pos.	Part Number	Pcs.
1	9003266	1
2	4009710	1
3	3005057	1
4	4014253	2
5	4009624	1
6	m12950	1
7	4014252	2
8	4009647	1
9	4015783	1
10	4007281	1
11	4014863	2
20	m06077	2
21	m10440	1
23	m14482	1
24	m15215	2
30	m06233	2
31	m10439	1
32	m12150	2
33	m05560	2
41	m12464	1
50	m14971	2

Ⓒ RADLICE

Ⓓ SCHARE

Ⓕ SOC

4009708_2

Ⓖ SHARE

Ⓡ ЛАПА

Ⓟ REDLICE

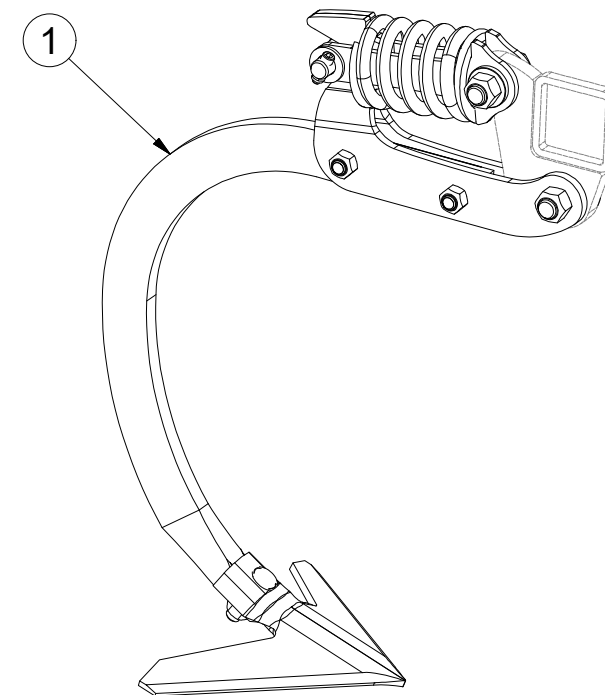
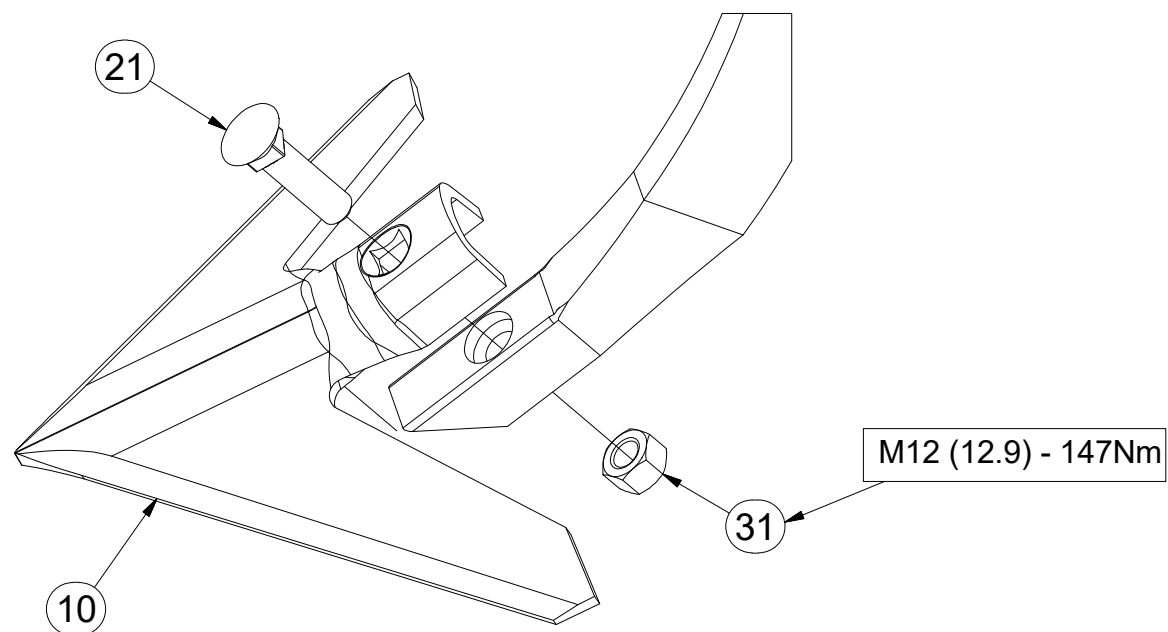
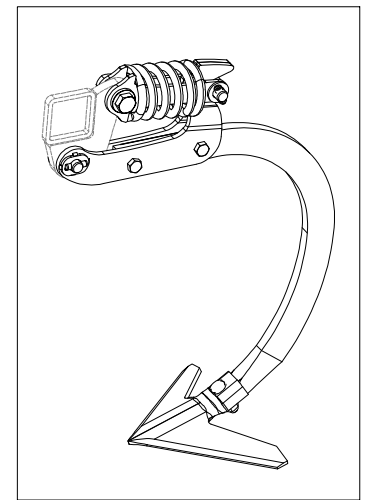
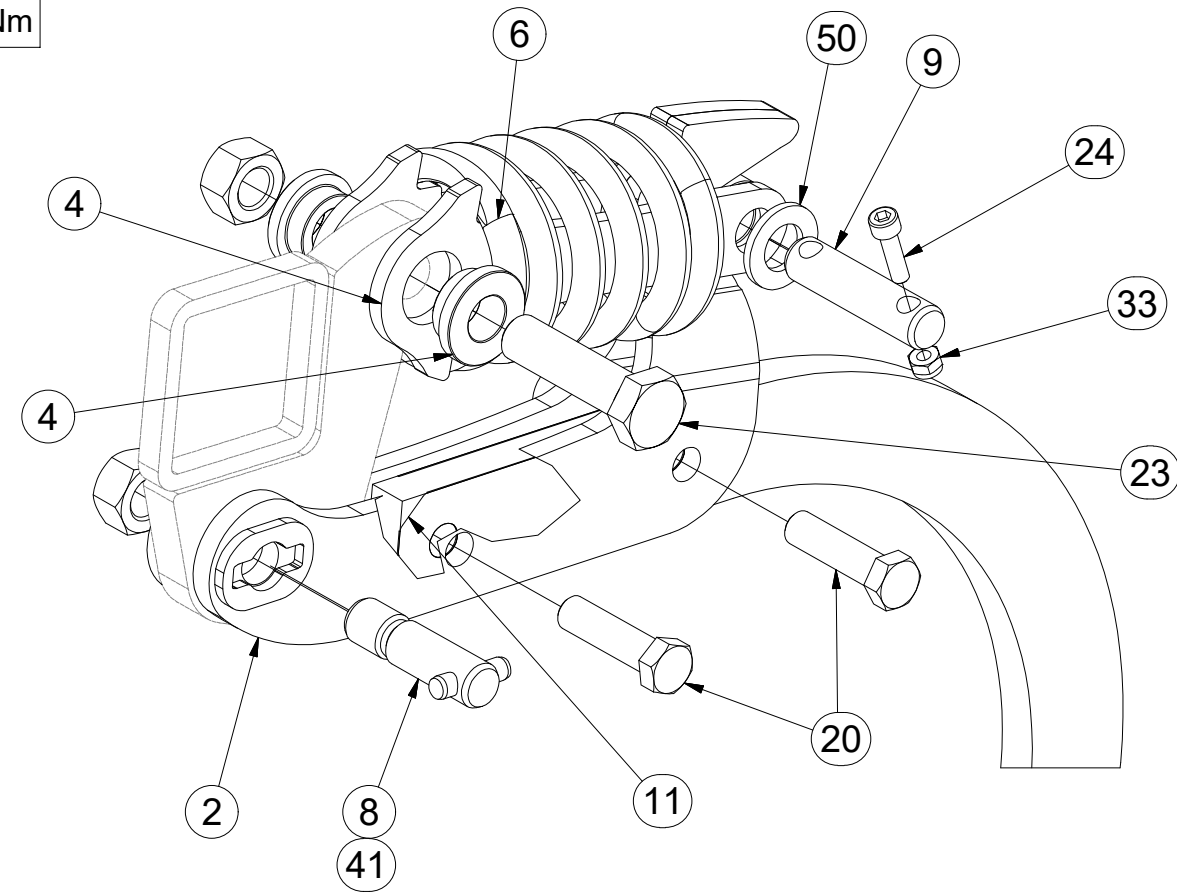
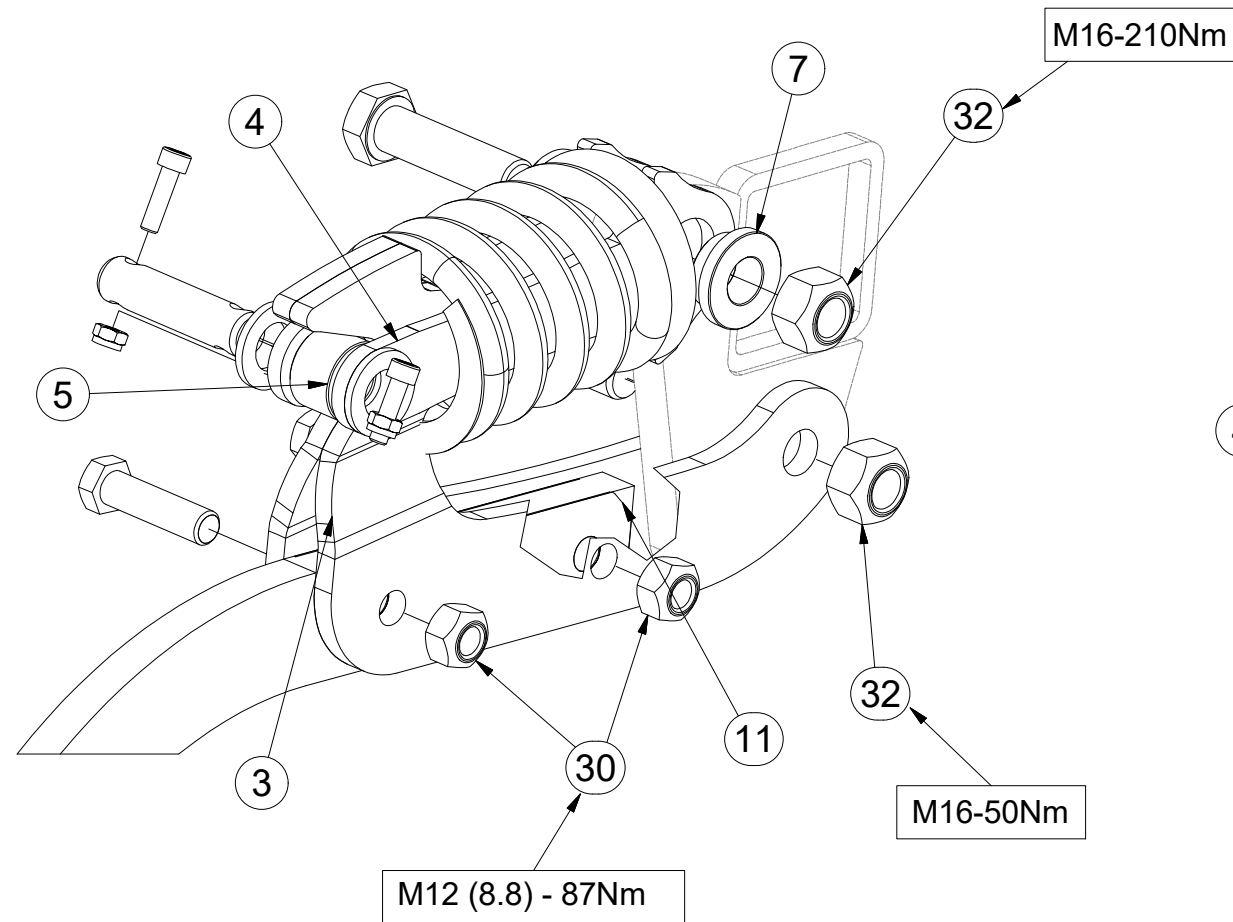

Pos.	Part Number	Pcs.
1	9003266	1
2	4009710	1
3	3005057	1
4	4014253	2
5	4009624	1
6	m12950	1
7	4014252	2
8	4009647	1
9	4015783	1
10	3000236-KOO	1
11	4014863	2
20	m06077	2
21	m10440	1
23	m14482	1
24	m15215	2
30	m06233	2
31	m10439	1
32	m12150	2
33	m05560	2
41	m12464	1
50	m14971	2

- Ⓒ SADA ZADNÍCH VÁLCŮ
- Ⓓ SATZ HINTERE WALZEN
- Ⓕ KIT DE ROULEAUX ARRIÈRE

- Ⓖ SET OF REAR ROLLERS
- Ⓡ КОМПЛЕКТ ЗАДНИХ КАТКОВ
- Ⓟ ZESTAW TYLNYCH WAŁÓW



3008670

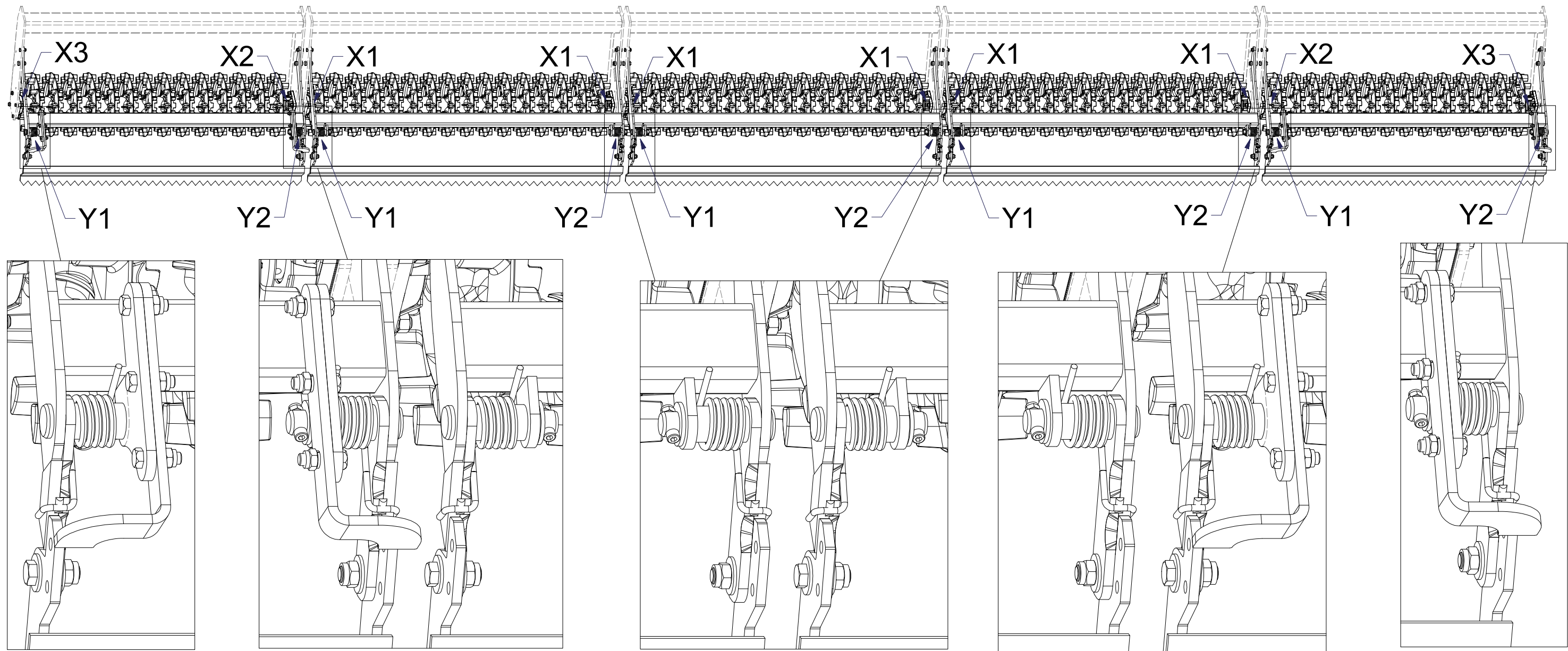

- Ⓒ SADA ZADNÍCH VÁLCŮ
- Ⓓ SATZ HINTERE WALZEN
- Ⓕ KIT DE ROULEAUX ARRIÈRE

- Ⓖ SET OF REAR ROLLERS
- Ⓡ КОМПЛЕКТ ЗАДНИХ КАТКОВ
- Ⓟ ZESTAW TYLNYCH WAŁÓW



3008670

X1

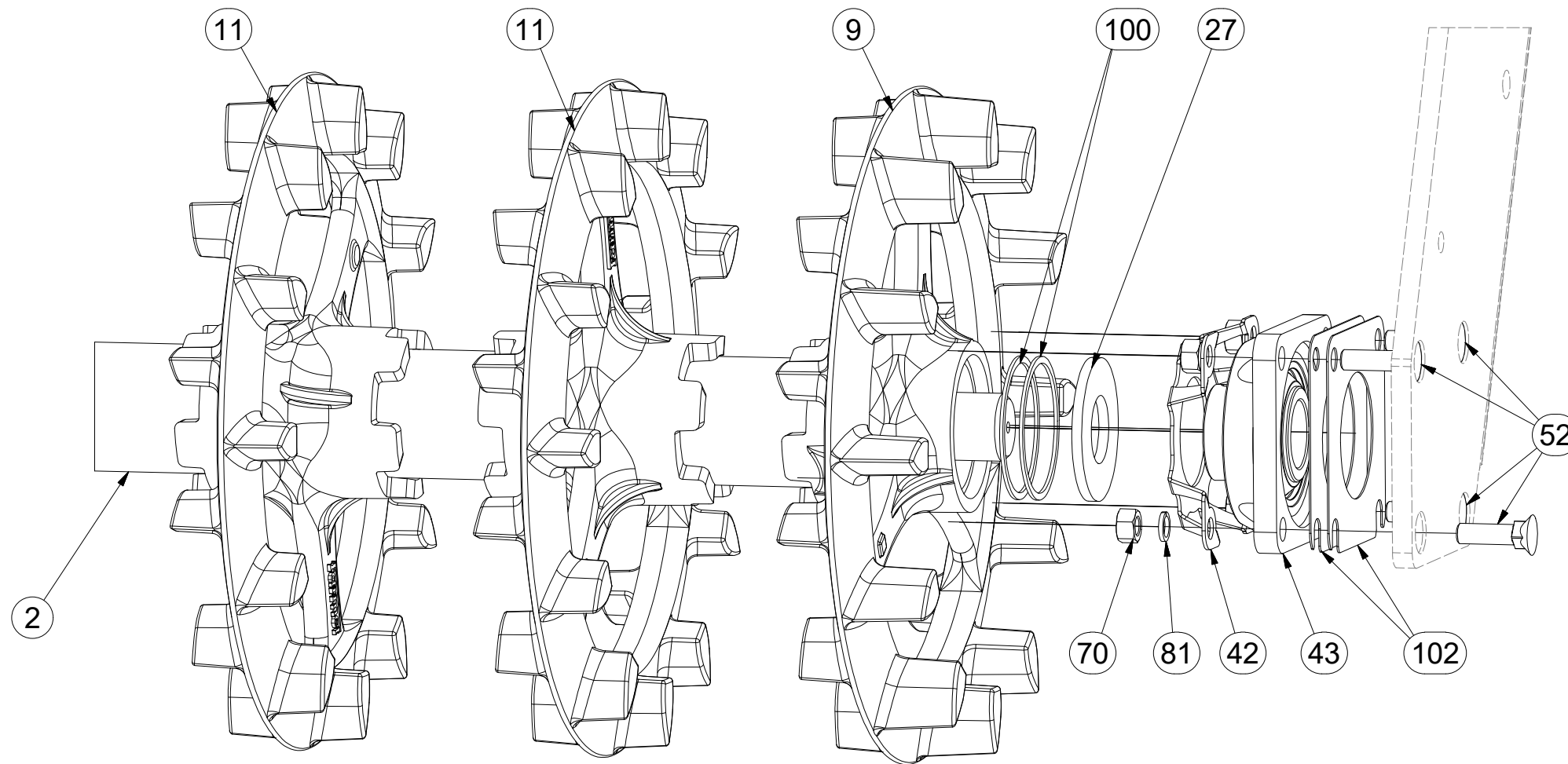
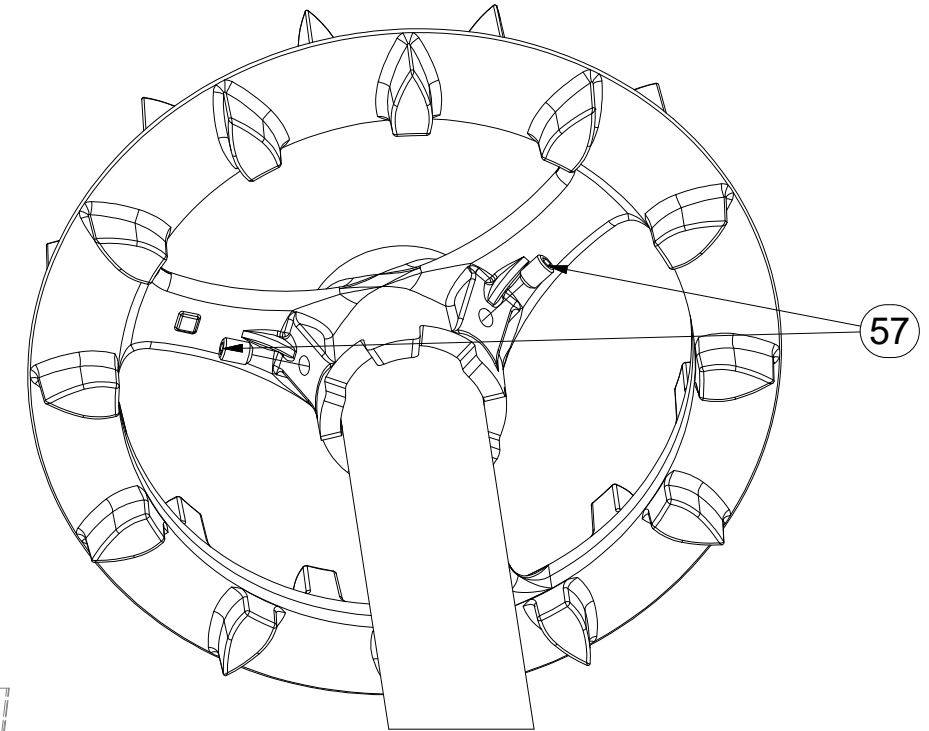
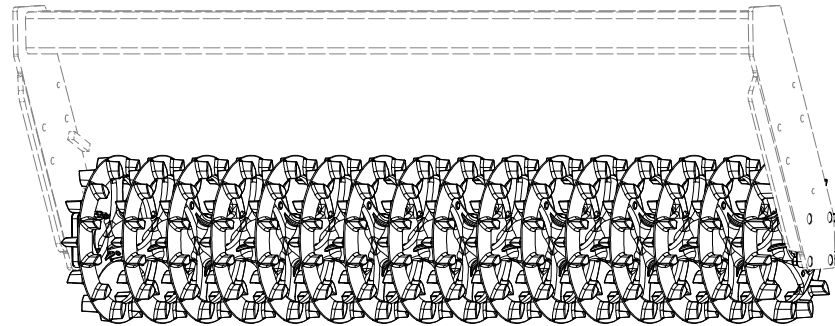

Pos.	Part Number	Pcs.
2	3001805	3
9	4009333	6
11	9002944	66
27	4016995	6
42	4014034	10
43	m15625	10
52	m03519	32
57	m13958	20
70	m01305	40
81	m03988	52
84	m14028	10
100	4010015	12
102	4016809	20

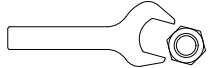

M12 (10.9) - 88Nm

M12 (8.8) - 87Nm

CZ SADA ZADNÍCH VÁLCŮ
 D SATZ HINTERE WALZEN
 F KIT DE ROULEAUX ARRIÈRE

GB SET OF REAR ROLLERS
 RU КОМПЛЕКТ ЗАДНИХ КАТКОВ
 PL ZESTAW TYLNYCH WAŁÓW



3008670

X2

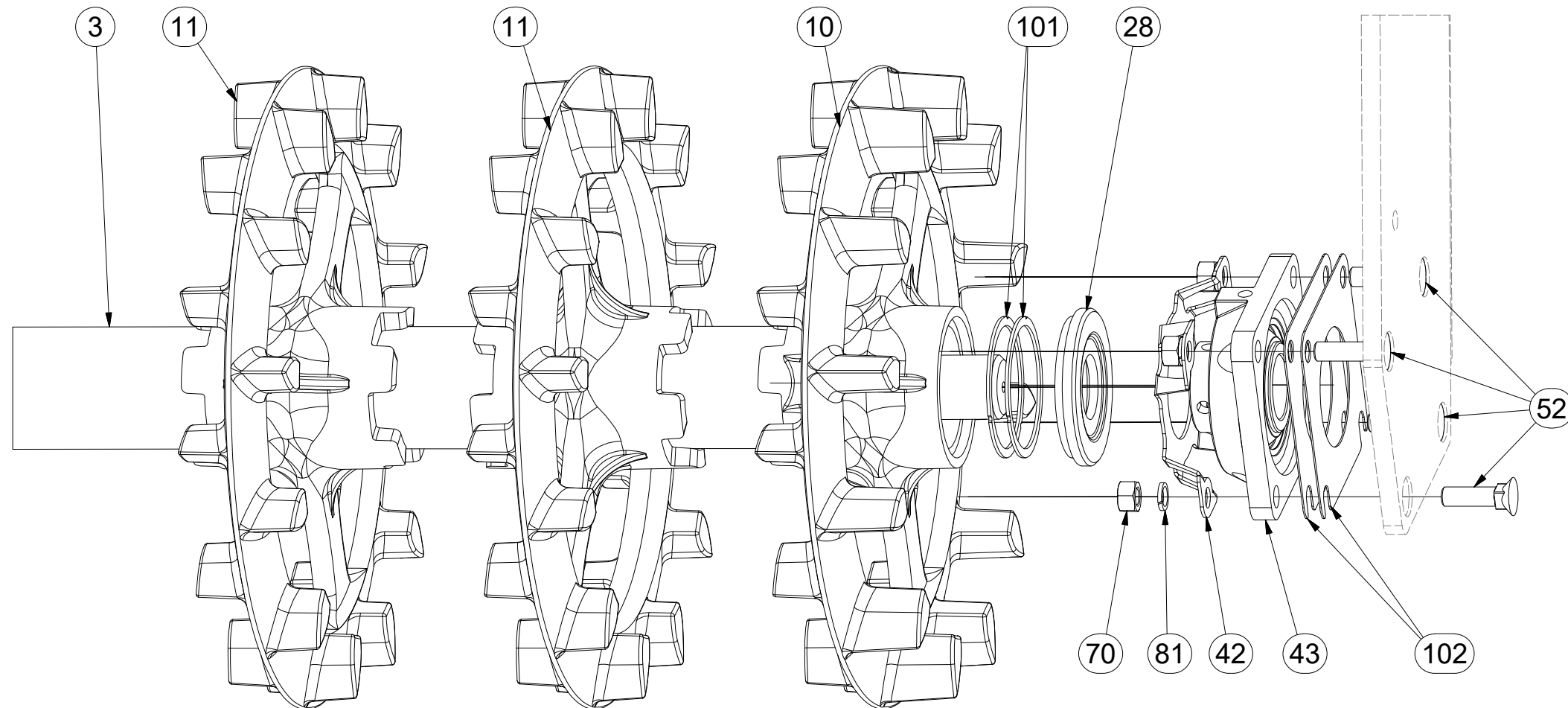
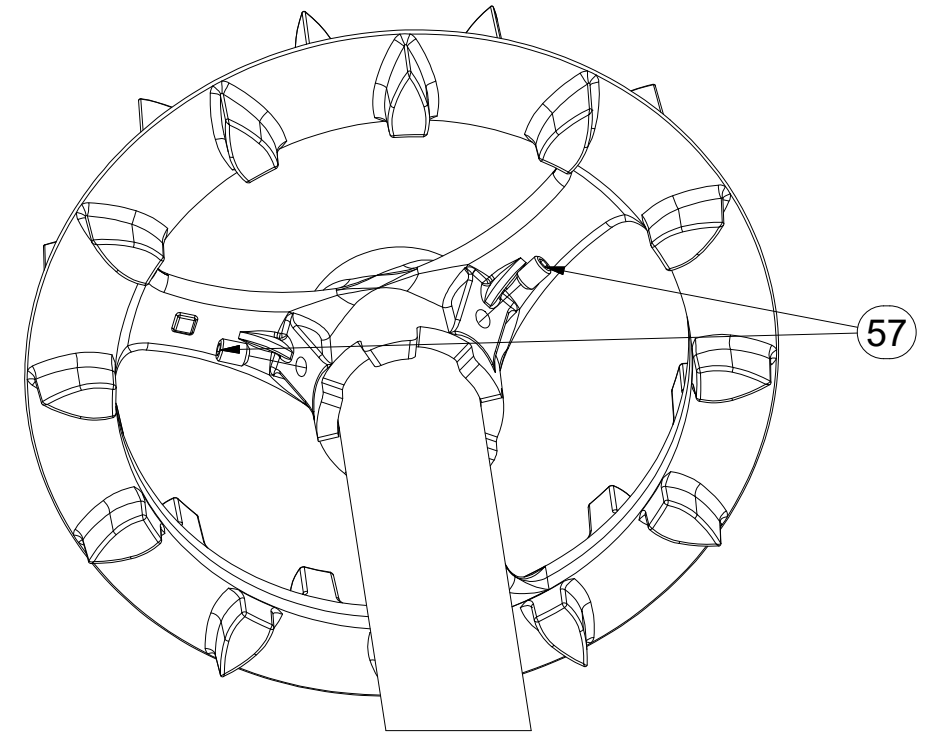
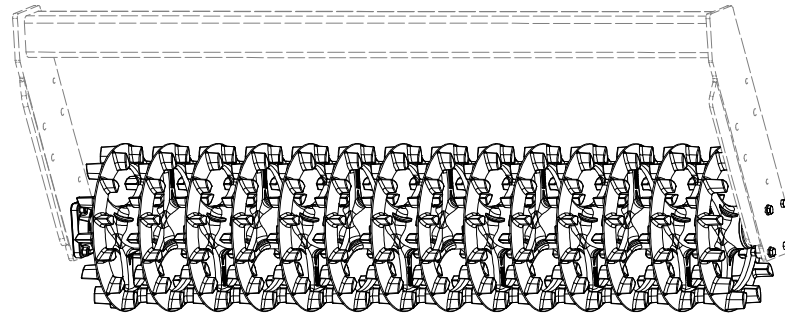

Pos.	Part Number	Pcs.
3	3008655	2
10	4009334	4
11	9002944	66
28	4016996	4
42	4014034	10
43	m15625	10
52	m03519	32
57	m13958	20
70	m01305	40
81	m03988	52
101	4010992	8
102	4016809	20

M12 (10.9) - 88Nm
M12 (8.8) - 87Nm

- Ⓒ SADA ZADNÍCH VÁLČŮ
- Ⓓ SATZ HINTERE WALZEN
- Ⓕ KIT DE ROULEAUX ARRIÈRE

- Ⓖ SET OF REAR ROLLERS
- Ⓡ КОМПЛЕКТ ЗАДНИХ КАТКОВ
- Ⓟ ZESTAW TYLNYCH WAŁÓW



3008670

X3

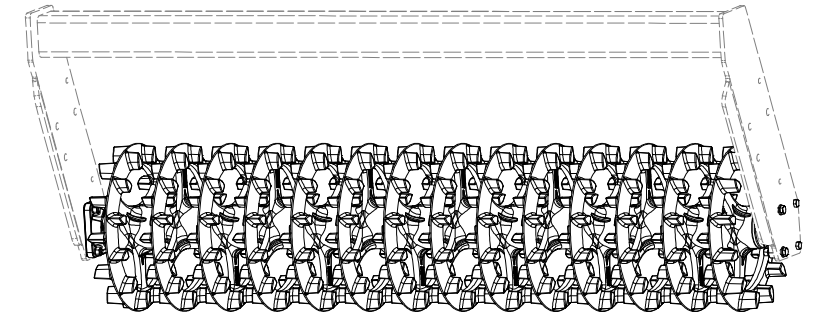
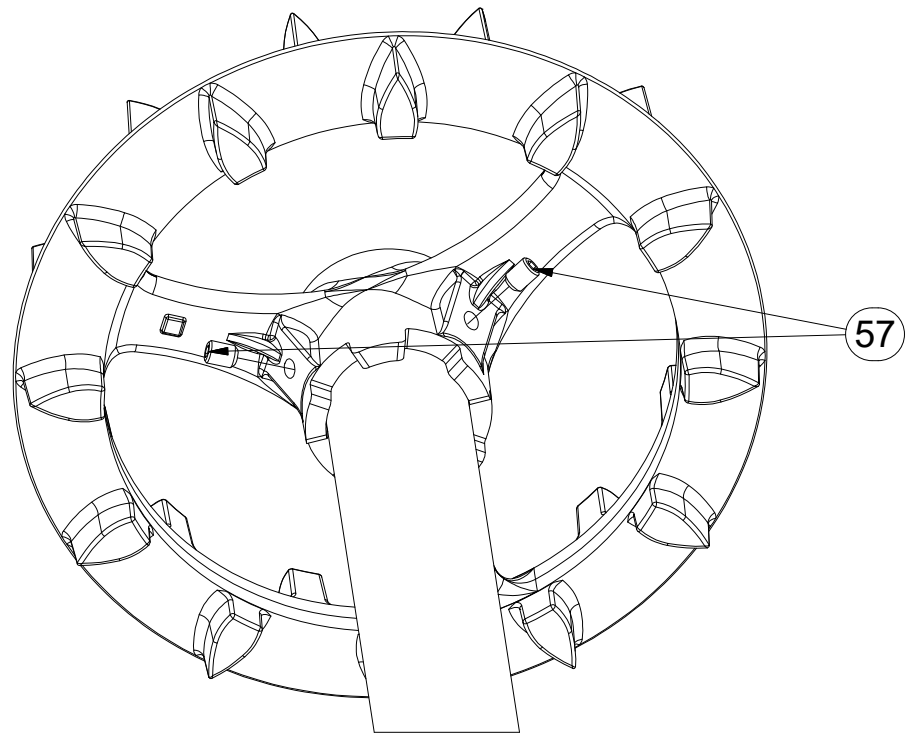

Pos.	Part Number	Pcs.
3	3008655	2
10	4009334	4
11	9002944	66
28	4016996	4
42	4014034	10
43	m15625	10
51	m06077	4
53	m03339	4
57	m13958	20
70	m01305	40
81	m03988	52
82	m01214	4
101	4010992	8
102	4016809	20

M12 (10.9) - 88Nm
M12 (8.8) - 87Nm

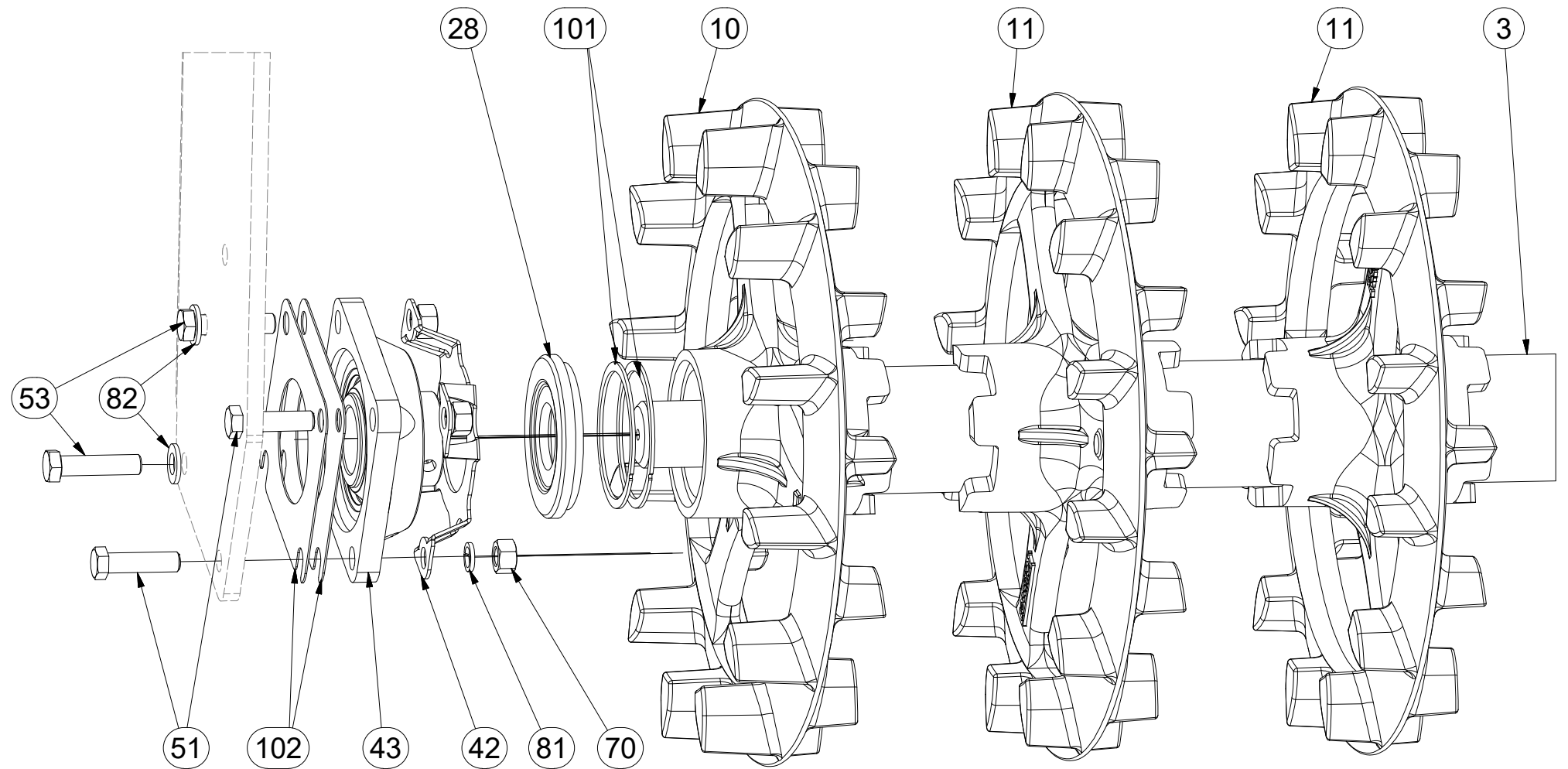

CZ SADA ZADNÍCH VÁLČŮ
 D SATZ HINTERE WALZEN
 F KIT DE ROULEAUX ARRIÈRE

GB SET OF REAR ROLLERS
 RU КОМПЛЕКТ ЗАДНИХ КАТКОВ
 PL ZESTAW TYLNYCH WAŁÓW



3008670

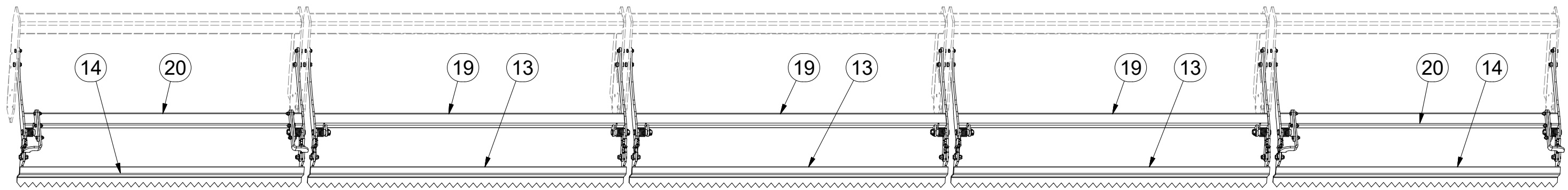

Y1

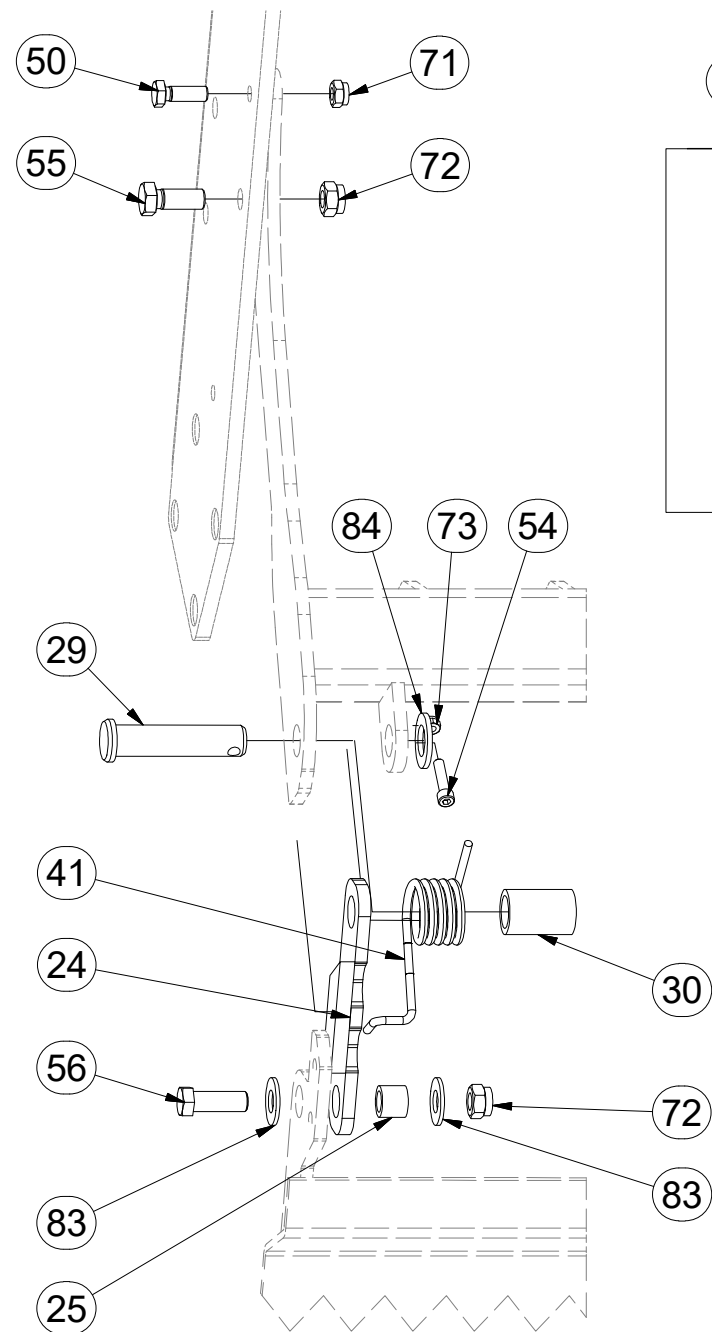

Y2

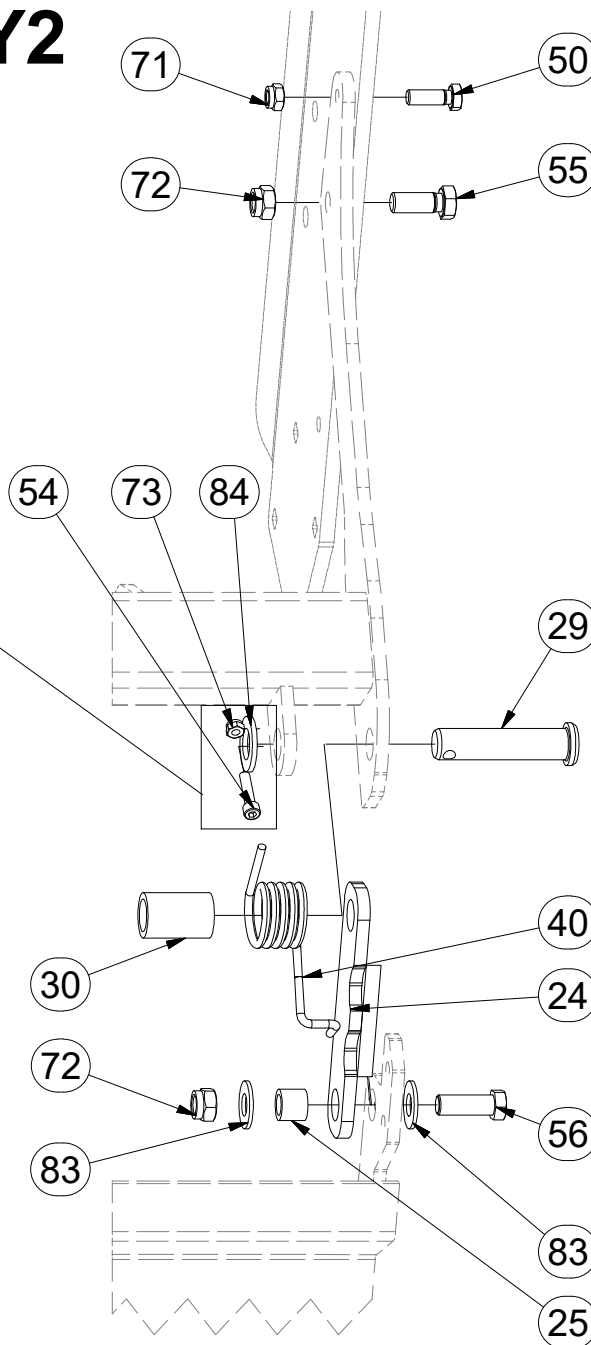

M8 (8.8) - 25Nm
M12 (8.8) - 87Nm
M16 (8.8) - 210Nm

Pos.	Part Number	Pcs.
13	3001672	3
14	3003051	2
19	3004896	3
20	3004900	2
24	4002269	10
25	4004451	10
29	4015778	10
30	9002979	10
40	m12303	5
41	m12304	5
50	m04343	10
54	m09464	10
55	m01129	10
56	m02254	10
71	m04301	22
72	m03683	20
73	m04503	10
83	m05651	20
84	m14028	10

- Ⓒ SADA ZADNÍCH VÁLCŮ
- Ⓓ SATZ HINTERE WALZEN
- Ⓕ KIT DE ROULEAUX ARRIÈRE

- Ⓖ SET OF REAR ROLLERS
- Ⓡ КОМПЛЕКТ ЗАДНИХ КАТКОВ
- Ⓟ ZESTAW TYLNYCH WAŁÓW



3008670

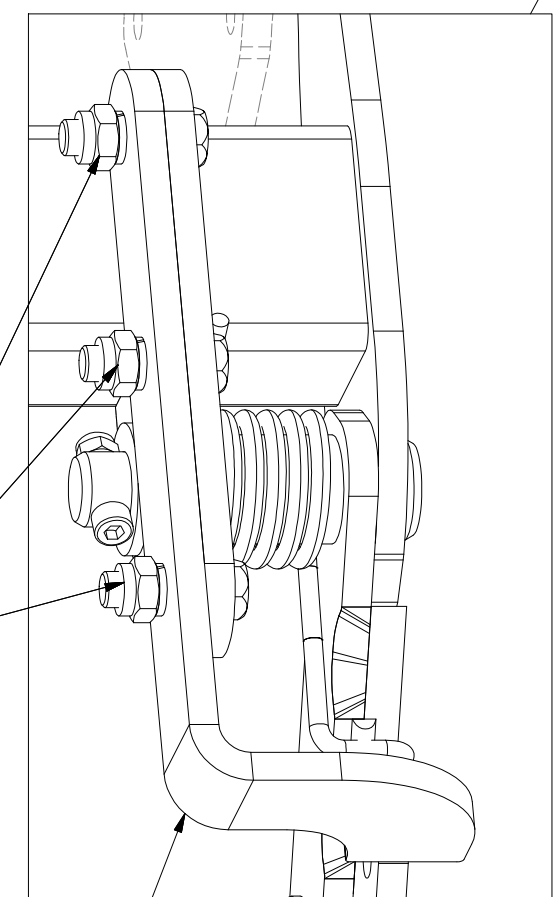
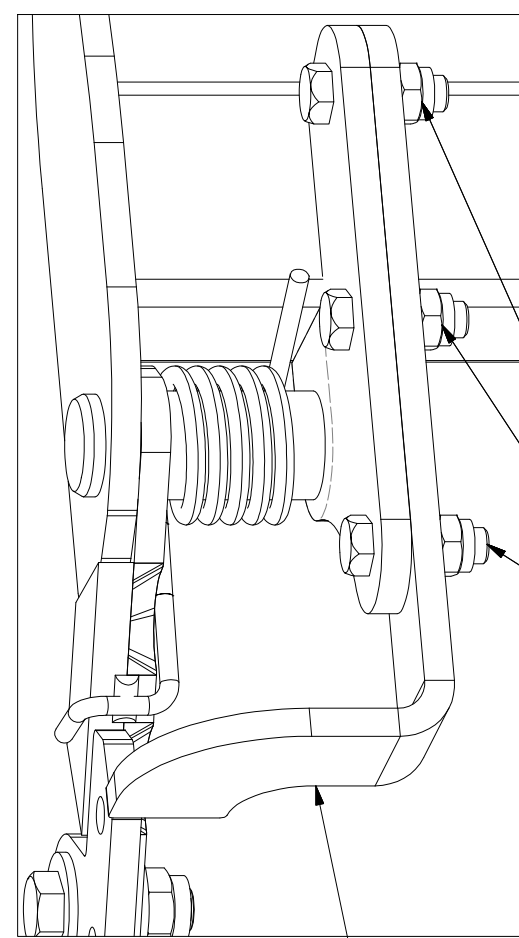
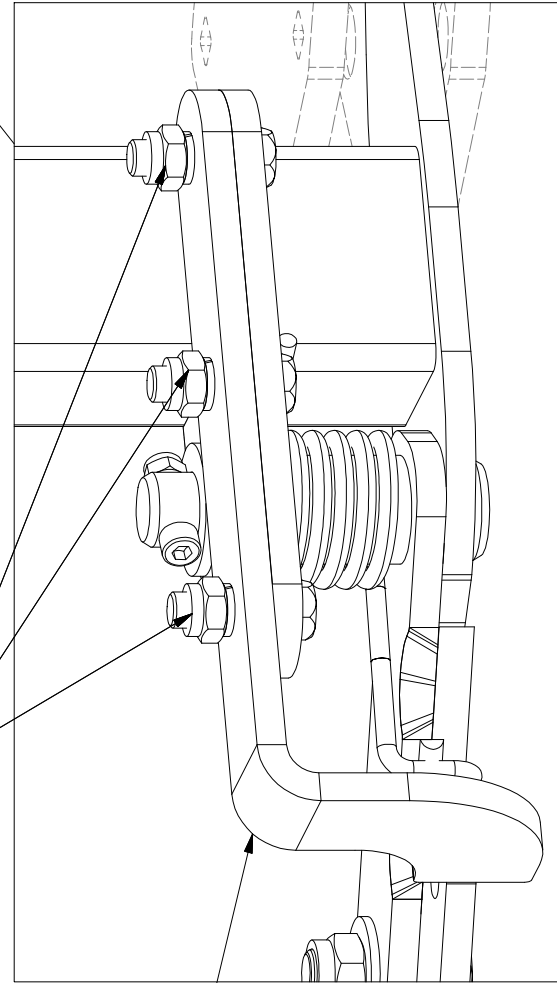
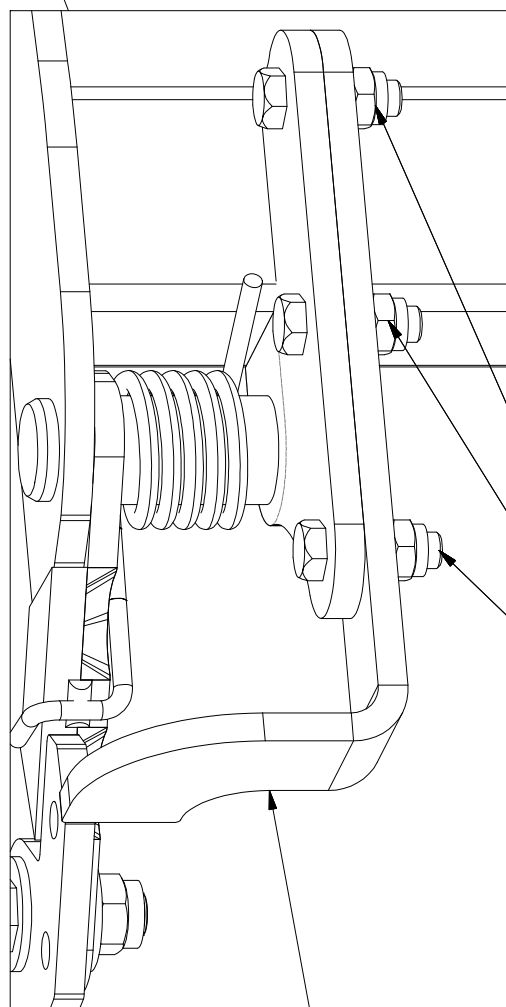
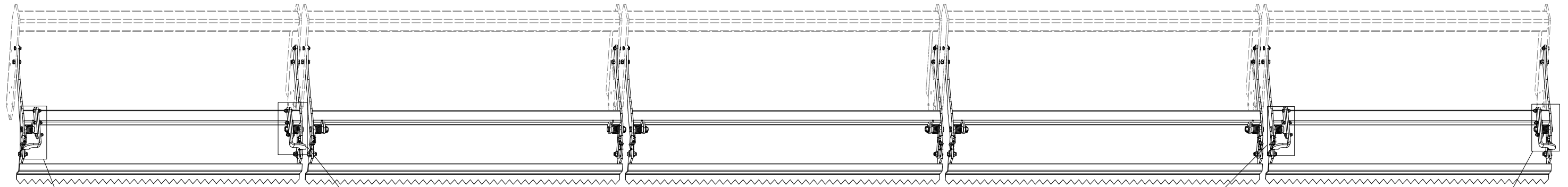

16

15

16

15

58

71

58

71

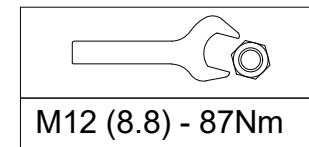

Pos.	Part Number	Pcs.
15	4013192	2
16	4013193	2
58	m03926	12
71	m04301	22

ⒸZ SADA DORAZŮ ZADNÍCH SMYKŮ

Ⓓ ANSCHLAGSATZ FÜR HINTERE ACKERSCHLEPPEN

Ⓕ KIT DE BUTÉES DES NIVELEURS ARRIÈRE

3006135

ⒼB SET OF REAR LEVELLING BAR STOPS

ⒺU КОМПЛЕКТ УПОРОВ ЗАДНИХ БОРОН

ⒽL ZESTAW DOCISKÓW TYLNYCH WŁÓK

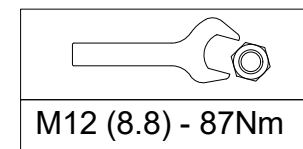
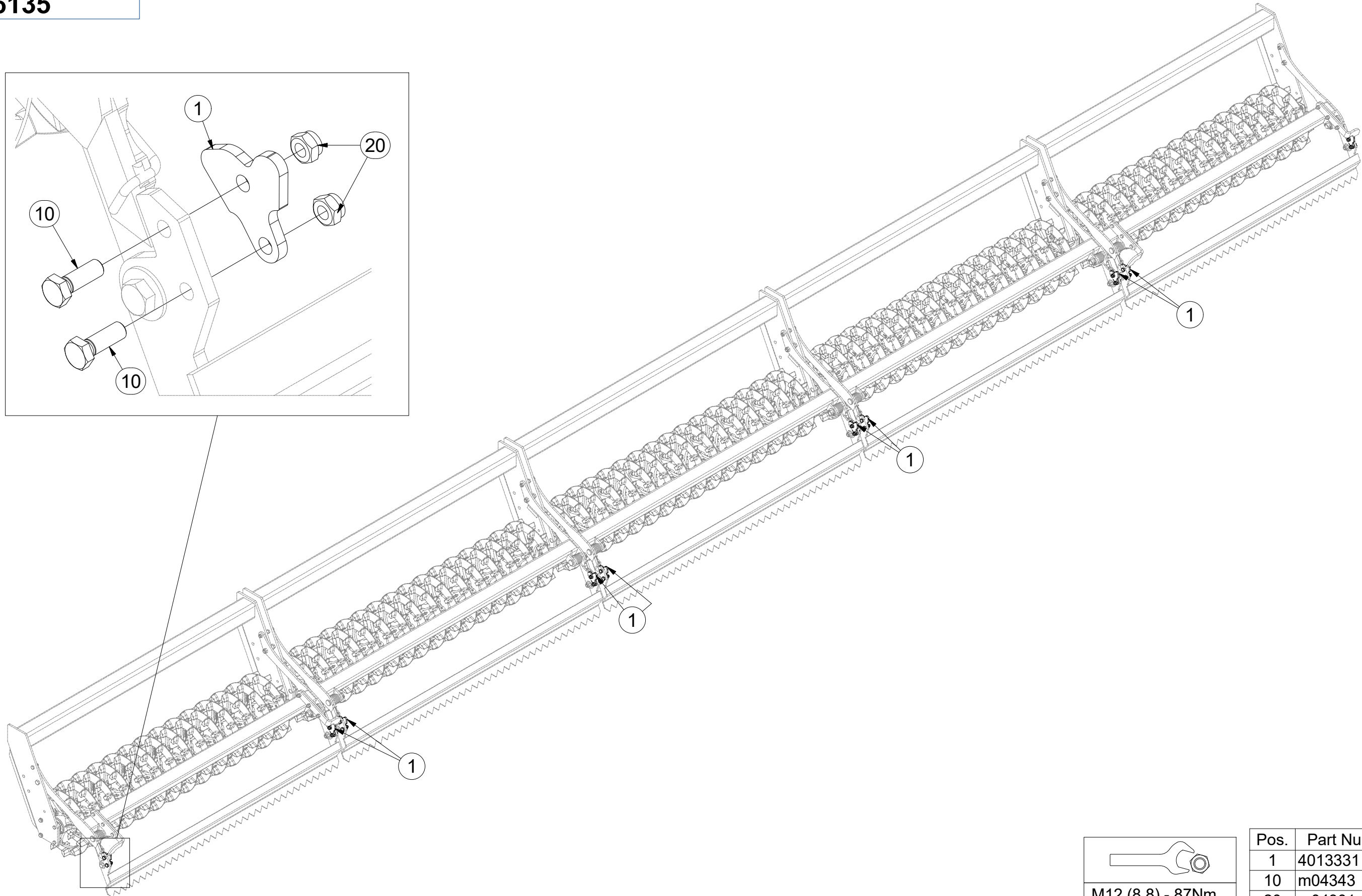

Pos.	Part Number	Pcs.
1	4013331	10
10	m04343	20
20	m04301	20

Ⓒ SADA NÁPRAVY

Ⓓ SATZ AUFHÄNGUNG

Ⓕ KIT DE L'ESSIEU

3006154

Ⓖ AXLE SET

Ⓡ КОМПЛЕКТ ОСИ КОЛЁС

Ⓢ ZESTAW OSI

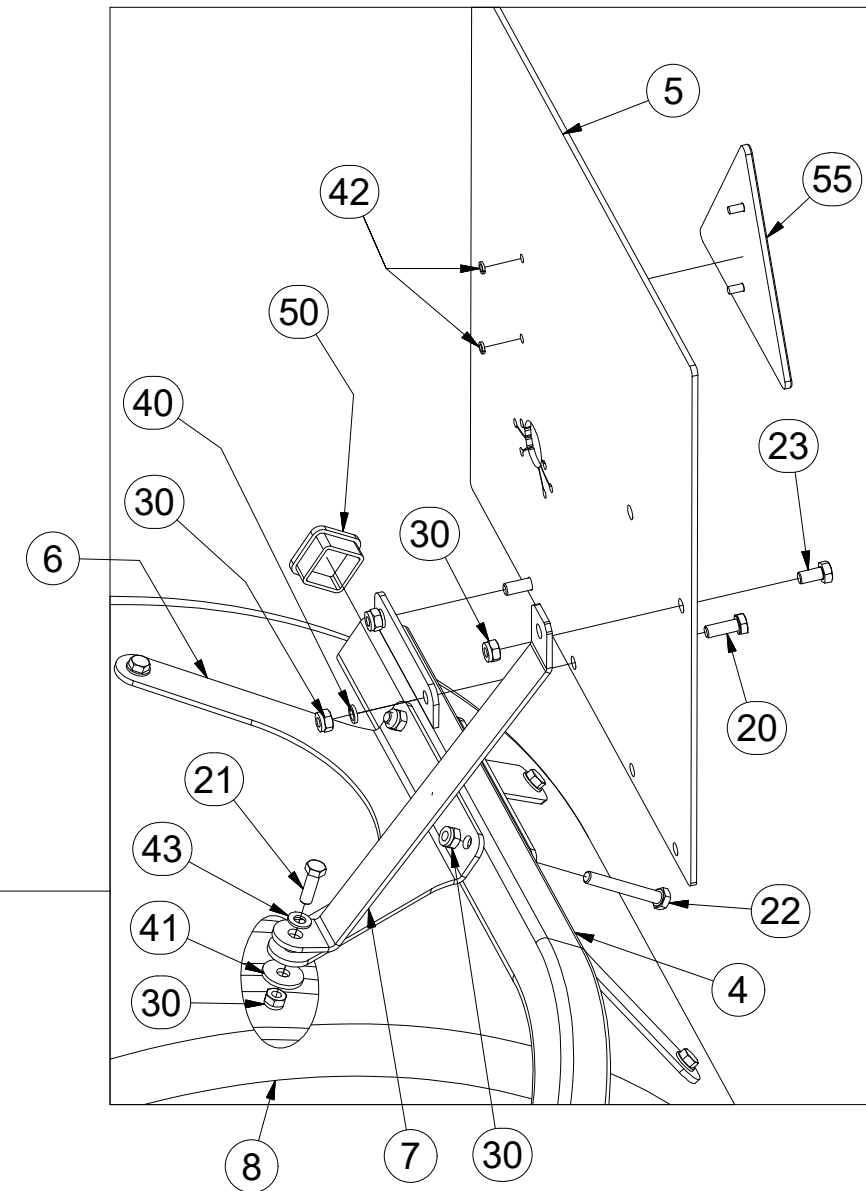
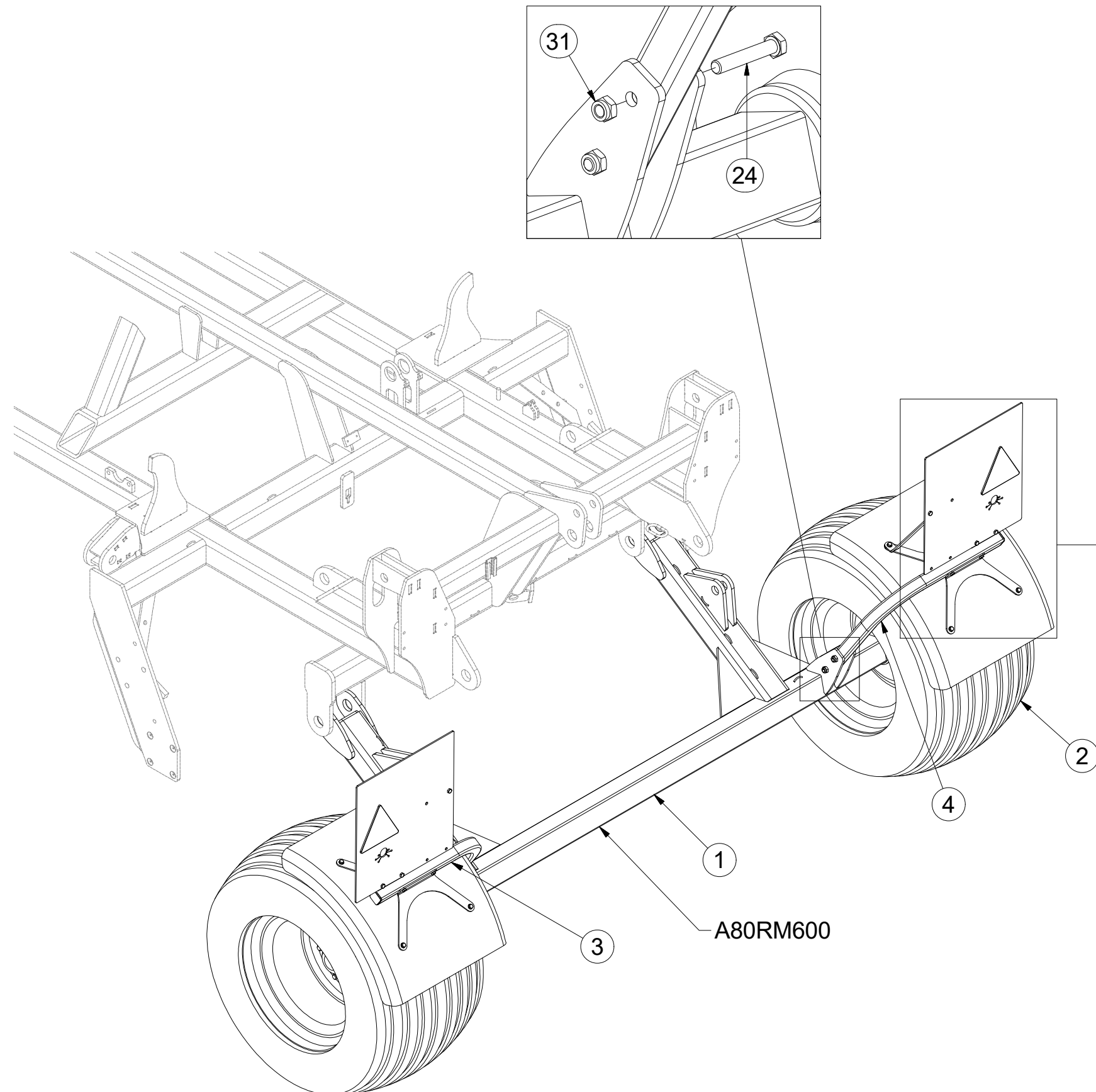

Pos.	Part Number	Pcs.	Pos.	Part Number	Pcs.
1	3004298	1	22	m14355	4
2	m11625	2	23	m04553	2
3	3007289	1	24	m14266	4
4	3007290	1	30	m04503	18
5	4014031	2	31	m04301	4
6	4014027	4	40	m01202	4
7	4014030	2	41	m07936	8
8	m09983	2	42	m01197	4
20	m01090	4	43	m01203	8
21	m01092	8	50	m12689	2
			55	m02497	2

Ⓒ NÁPRAVA

Ⓓ ACHSE

Ⓕ ESSIEU

Ⓖ AXLE

Ⓡ OCB

Ⓟ OS



A80RM600

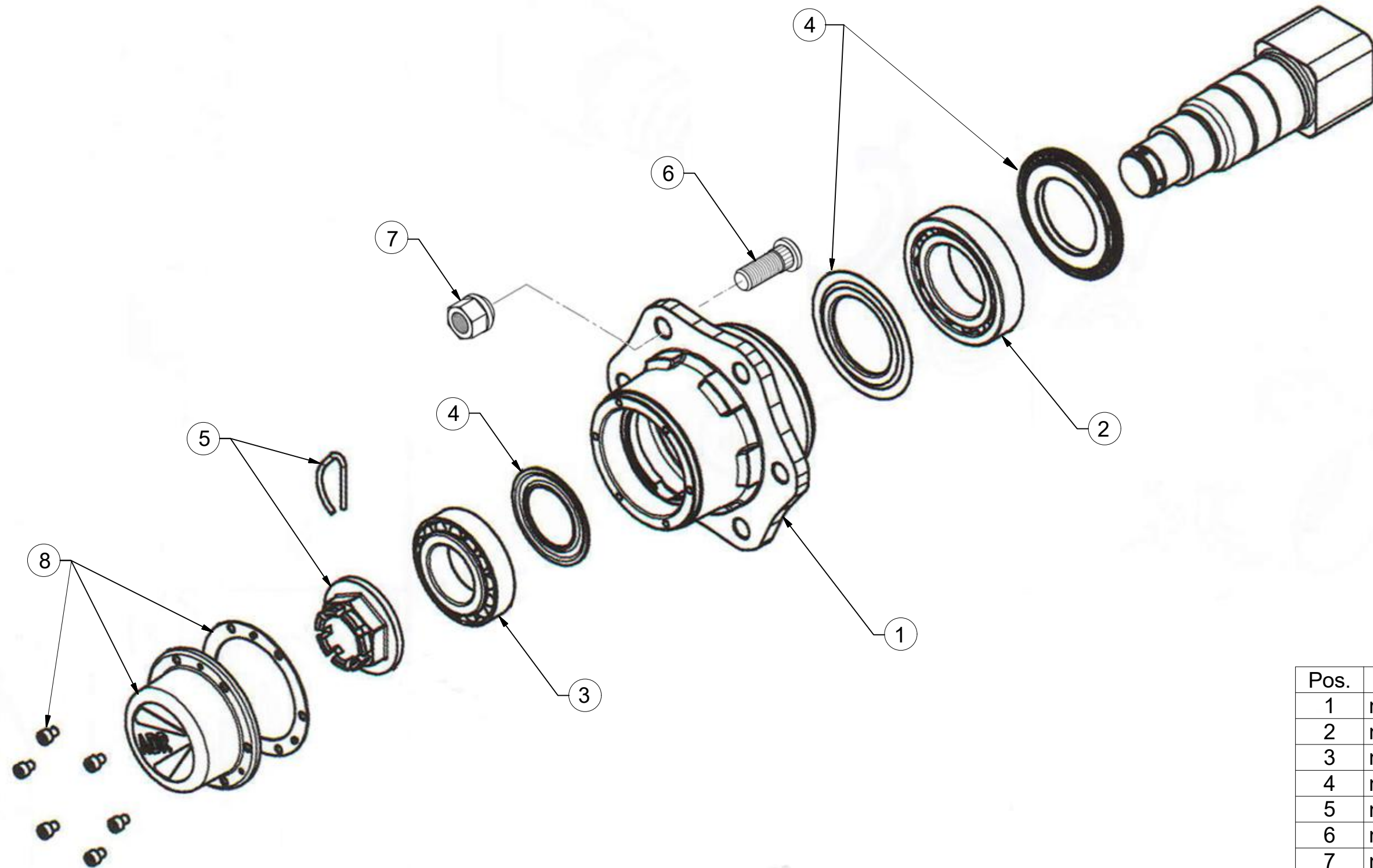

Pos.	Part Number	Pcs.
1	m12567	1
2	m07153	1
3	m07154	1
4	m12565	1
5	m08168	1
6	m08148	6
7	m08163	6
8	m12566	1

Ⓒ SVĚTELNÁ SADA

Ⓓ LEUCHTENSATZ

Ⓕ KIT LUMINEUX

Ⓖ LIGHTING SET

Ⓡ ОСВЕТИТЕЛЬНЫЙ КОМПЛЕКТ

Ⓟ ZESTAW OŚWIETLENIA



3008454

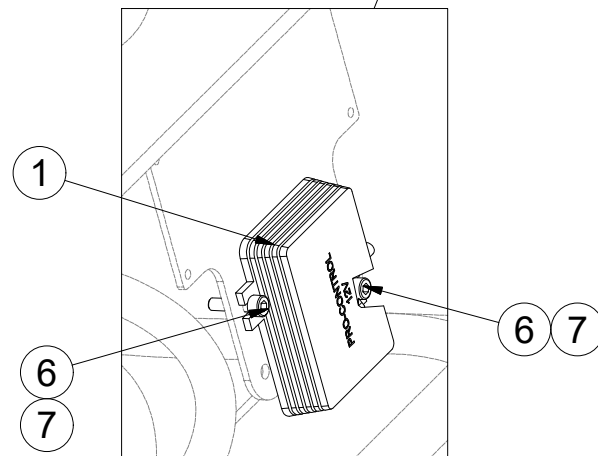
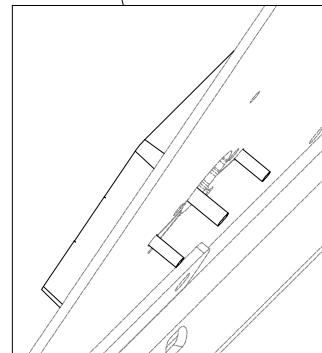
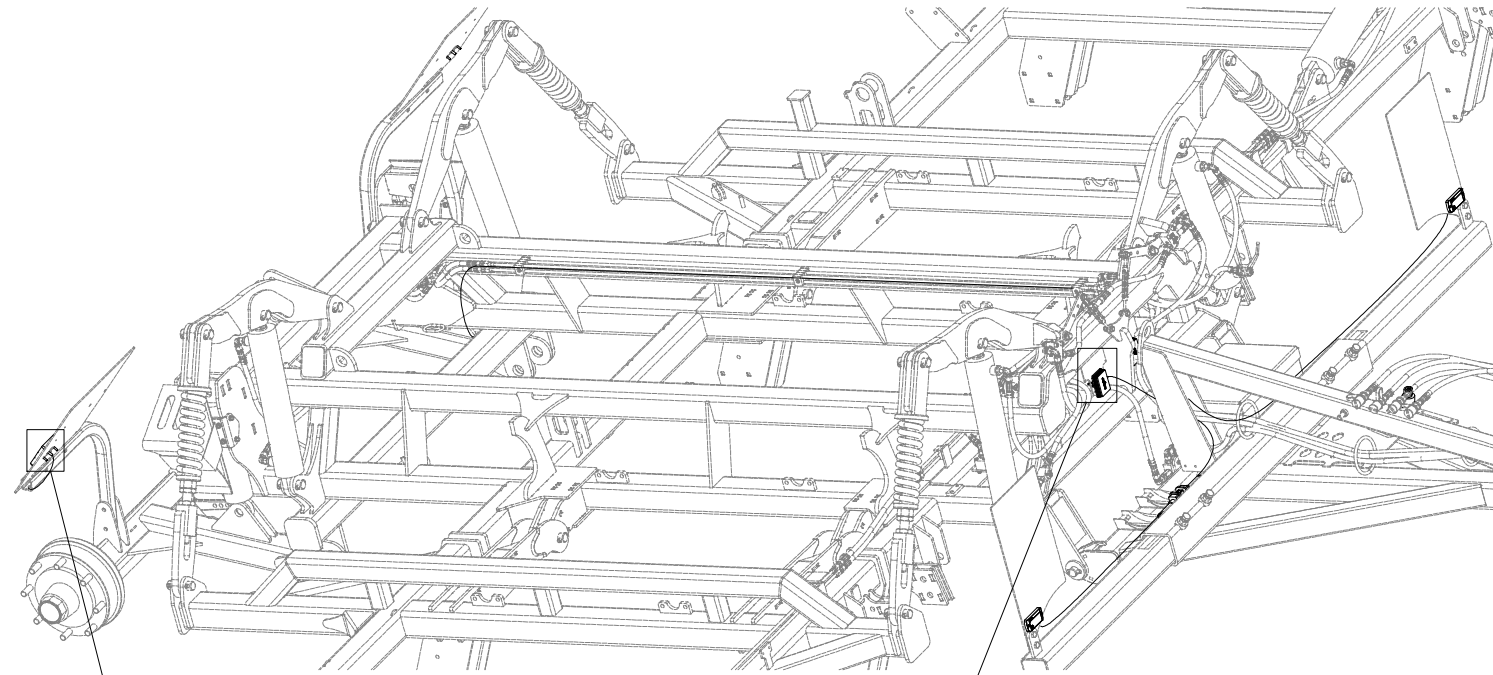

Pos.	Part Number	Pcs.
1	m15240	1
3	m05562	4
4	m05597	4
5	m15790	4
6	m10591	4
7	m06236	4
30	m05566	50

KOMPAKTOMAT K1000PS

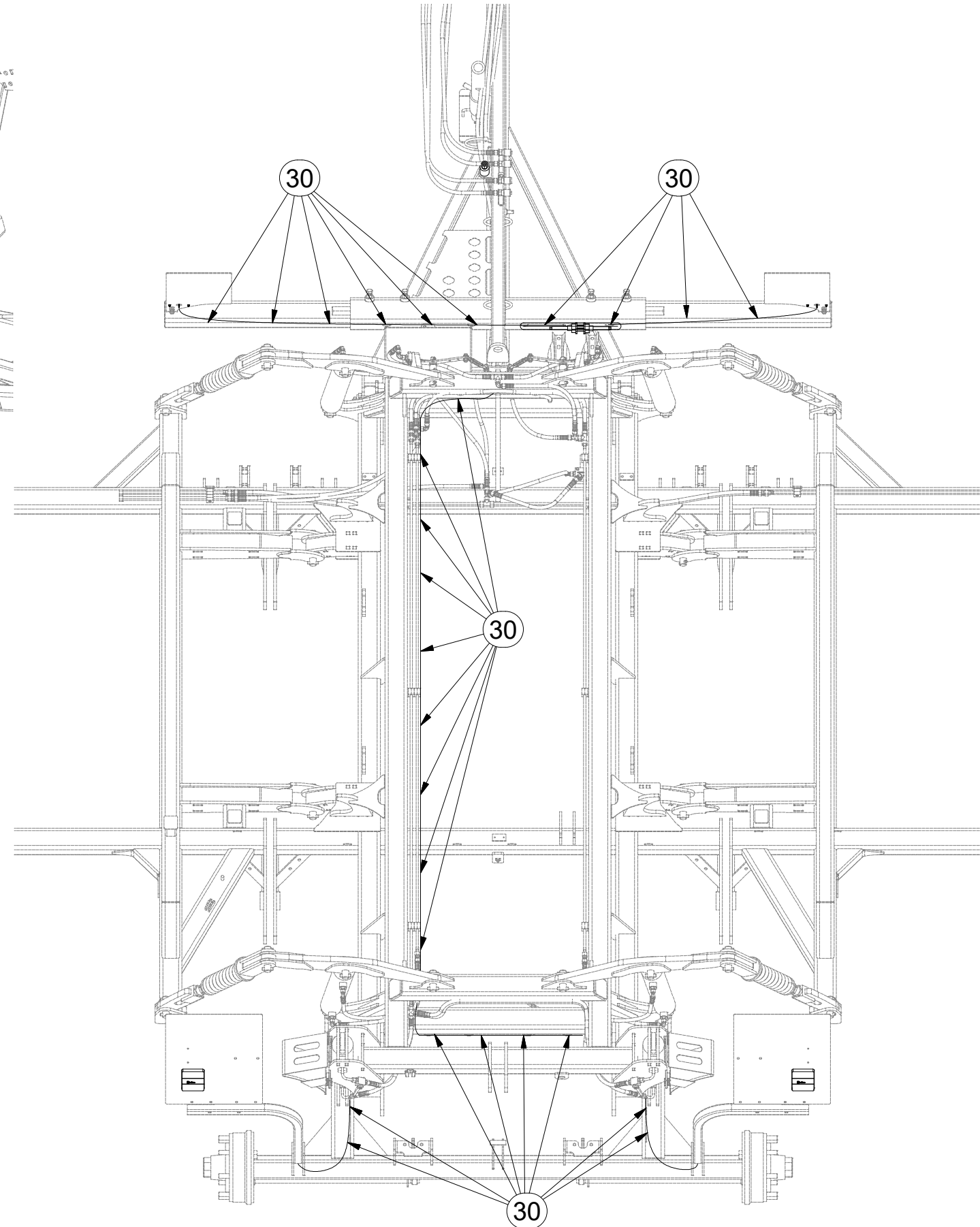

Ⓒ SVĚTELNÁ SADA

Ⓓ LEUCHTENSATZ

Ⓕ KIT LUMINEUX

Ⓖ LIGHTING SET

Ⓡ ОСВЕТИТЕЛЬНЫЙ КОМПЛЕКТ

Ⓟ ZESTAW OŚWIETLENIA



3008454

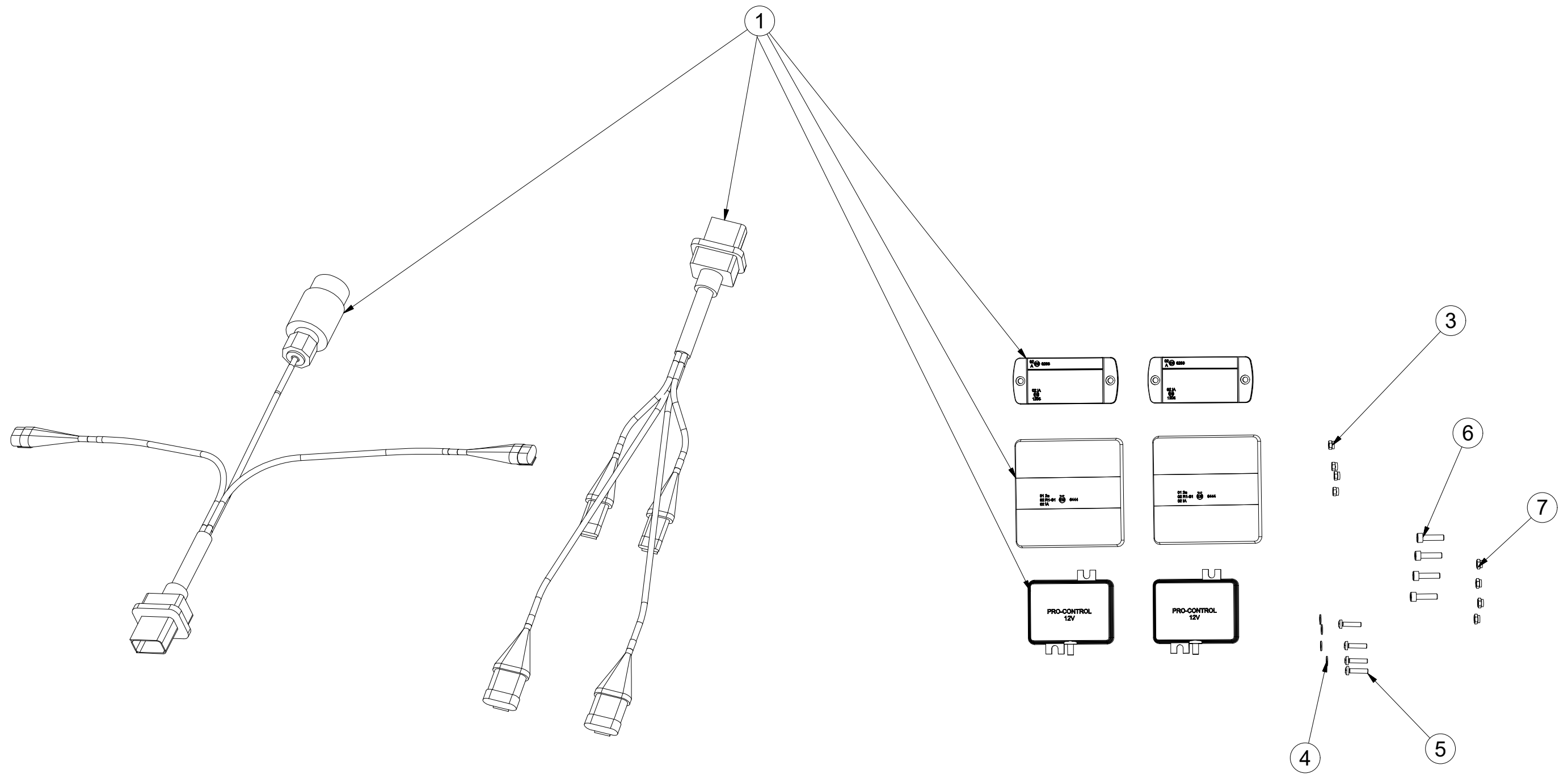

Pos.	Part Number	Pcs.
1	m15240	1
3	m05562	4
4	m05597	4
5	m15790	4
6	m10591	4
7	m06236	4
30	m05566	50

Ⓒ SVĚTELNÁ SADA

Ⓓ LEUCHTENSATZ

Ⓕ KIT LUMINEUX

m15240

Ⓖ LIGHTING SET

Ⓡ ОСВЕТИТЕЛЬНЫЙ КОМПЛЕКТ

Ⓟ ZESTAW OŚWIETLENIA

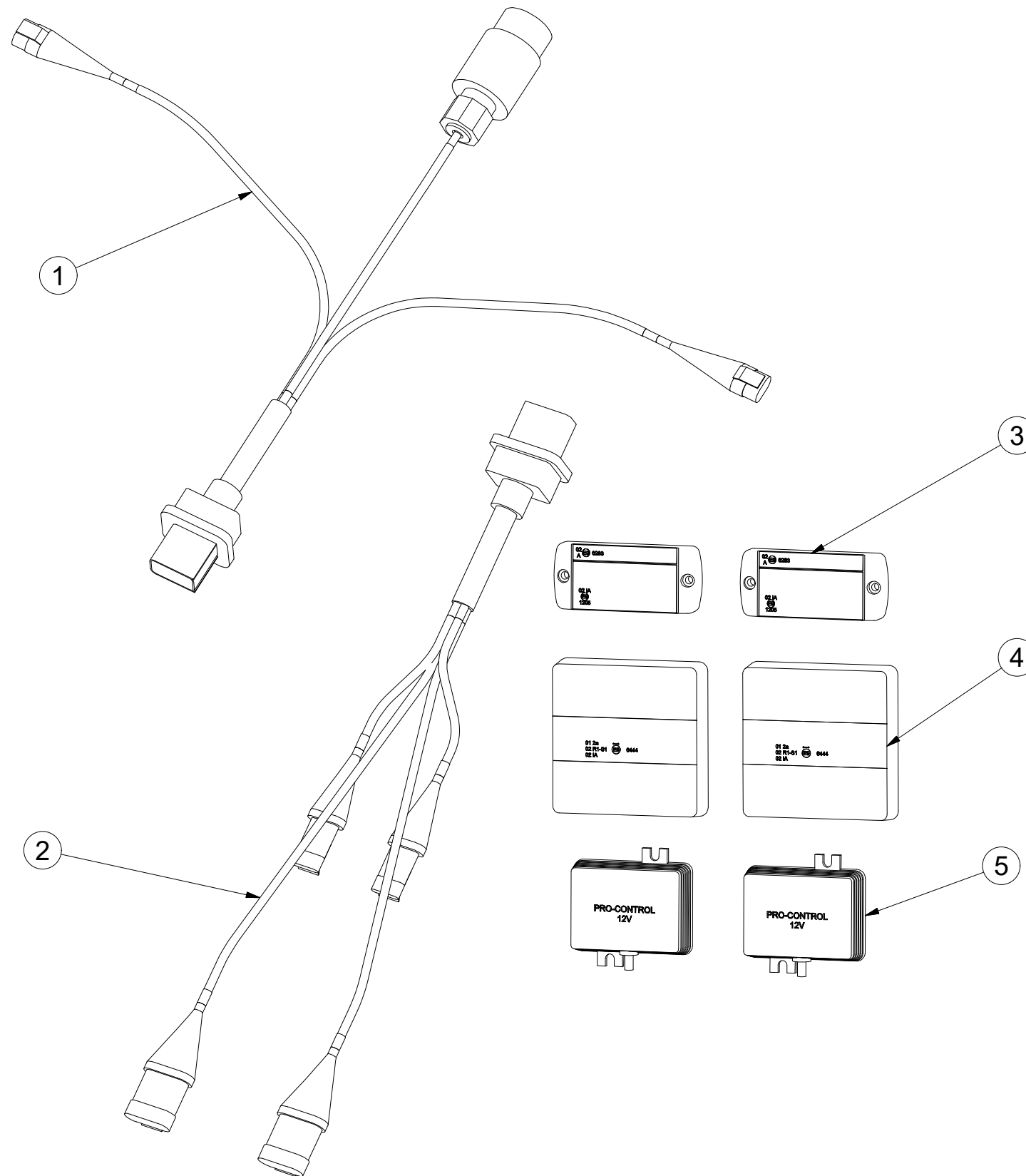

Pos.	Part Number	Pcs.
1	m14779	1
2	m14778	1
3	m14776	2
4	m14865	2
5	m14777	2

ⒸZ SOUPRAVA TĚSNIVA PÍSTNIC

Ⓓ KOLBENSTANGENDICHTUNGSMITTELSATZ

Ⓕ SET DE GARNITURE DES TIGES DE PISTON

ⒼB SEALING SET FOR PISTON RODS

ⒶU КОМПЛЕКТ ПРОКЛАДОК ЦИЛИНДРОВ

ⒶL ZESTAW USZCZELEK TRZPIENIA TŁOKA

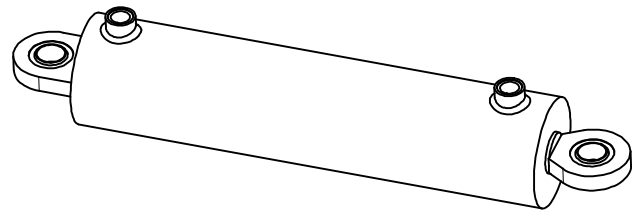

1

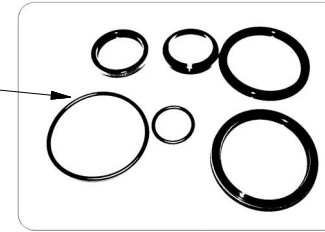

9002967 - $\varnothing 100/\varnothing 45-400$		
Pos	Part number	Pcs
1	m05504	1

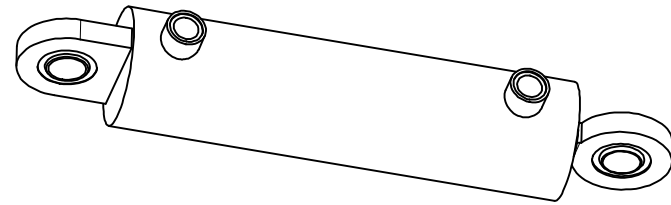

2

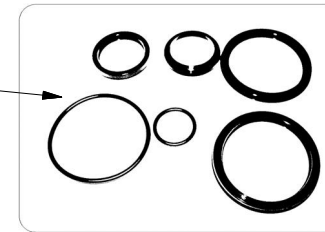

9000247 - $\varnothing 80/\varnothing 40-250$		
Pos	Part number	Pcs
2	m03528	3

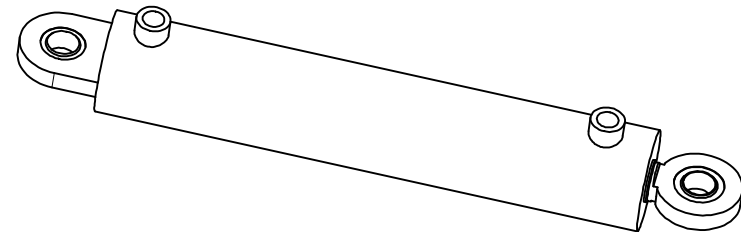

3



9000248 - $\varnothing 80/\varnothing 40-400$		
Pos	Part number	Pcs
3	m03528	4