

The effective technology

Farmet®

ⒸZ KATALOG NÁHRADNÍCH DÍLŮ ⒸB CATALOGUE OF SPARE PARTS ⒸD ERSATZTEILLISTE
ⒸRU КАТАЛОГ ЗАПАСНЫХ ЧАСТЕЙ ⒸF CATALOGUE DES PIÈCES DE RECHANGE ⒸPL KATALOG CZĘŚCI ZAMIENNYCH

КОМПАКТОМАТ K800PS

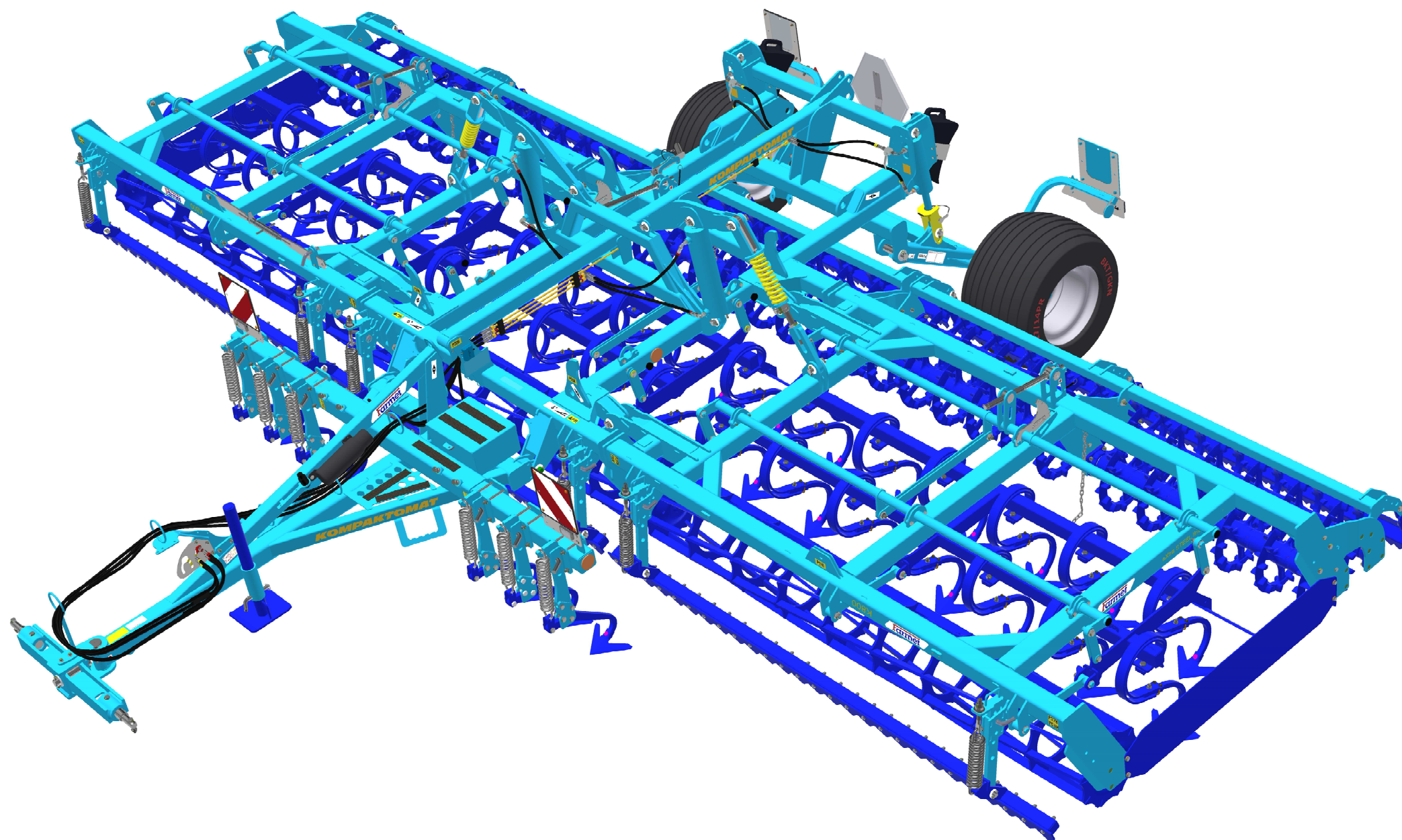

ⒸZ Platnost pro vrcholové | výrobní číslo stroje ⒸB Validity for the top | serial number of the machine
ⒸD Gültigkeit für die Haupt- | Herstellungsnummer der Maschine ⒸRU Действительно для главного | заводского номера машины
ⒸF Validité du numéro de référence | de série de la machine ⒸPL Obowiązuje dla numeru głównego | seryjnego maszyny

9333647 | 2022/0135

Farmet a. s.
Jiřinková 276
552 03 Česká Skalice, CZ

telefon: +420 491 450 111
fax: +420 491 450 136
GSM: +420 774 715 738

IČ: 46504931
DIČ: CZ46504931

web: www.farmet.cz
e-mail: farmet@farmet.cz

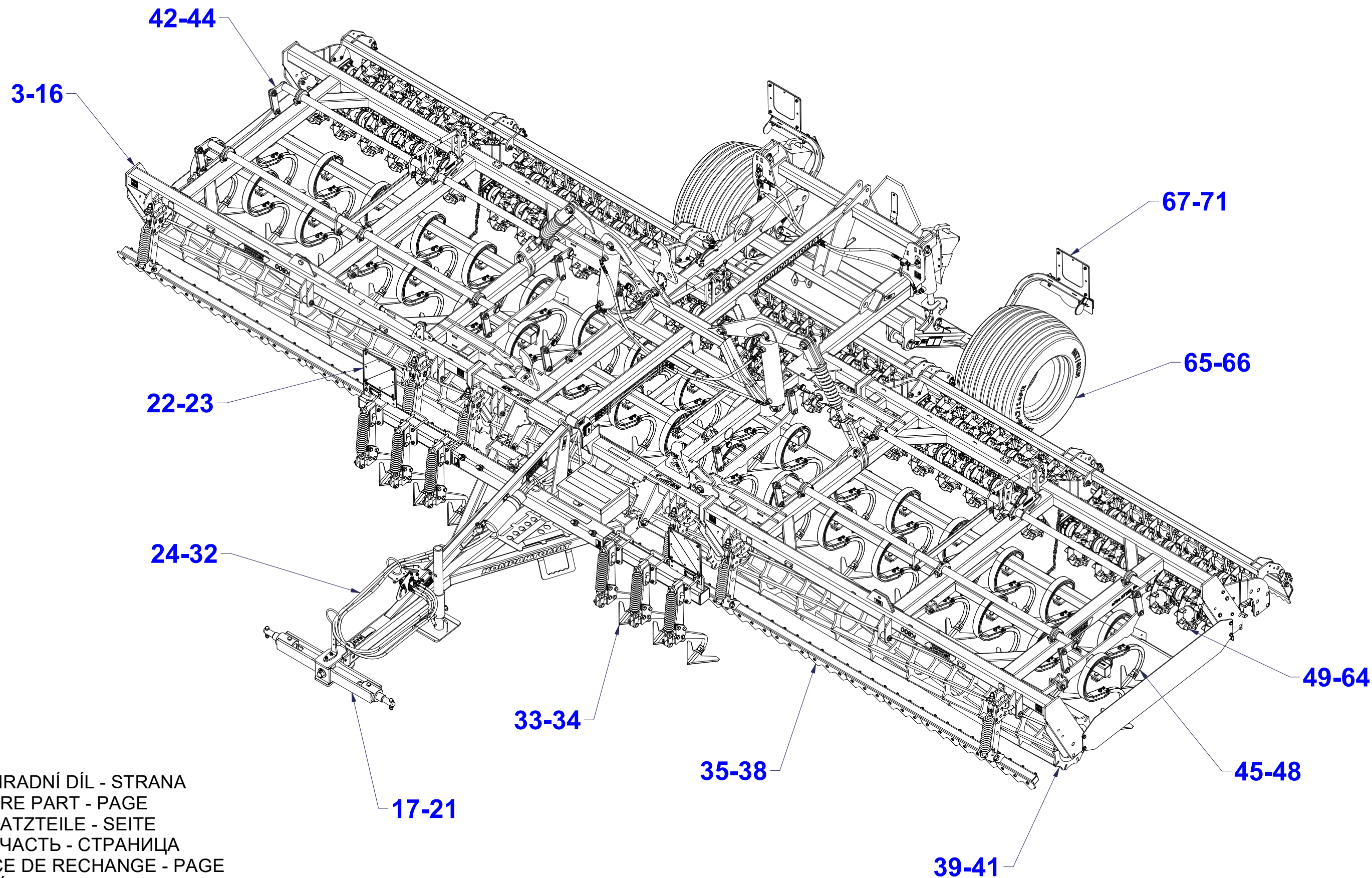

Ⓒ POLOTOVAR STROJE

Ⓓ MASCHINEN-HALBFABRIKAT

Ⓕ MACHINE - SEMI-PRODUIT

Ⓖ SEMIFINISHED MACHINE

Ⓡ ПОЛУФАБРИКАТ МАШИНЫ

Ⓢ РÓЉФАБРЫКАТ МАСЗЫНЫ



VZ00019240

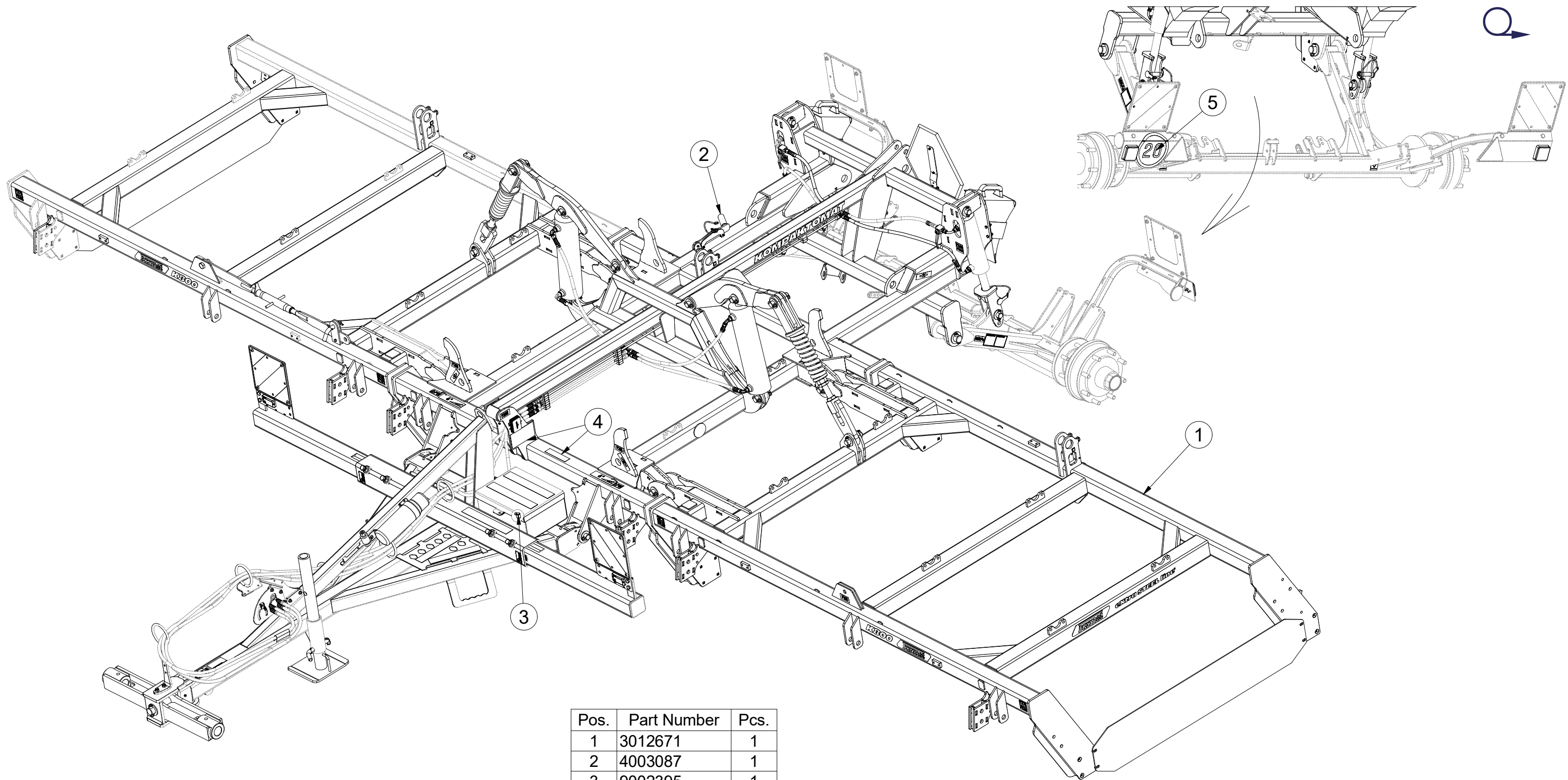

Pos.	Part Number	Pcs.
1	3012671	1
2	4003087	1
3	9002395	1
4	4025948	1
5	4026236	1

Ⓒ NASAZOVACÍ KLIKA

Ⓓ MONTAGEGRIF

Ⓕ POIGNÉE DE MONTAGE

4003087

Ⓖ MOUNTING HANDLE

Ⓡ МОНТАЖНАЯ РУЧКА

Ⓢ UCHWYT MONTAŻOWY

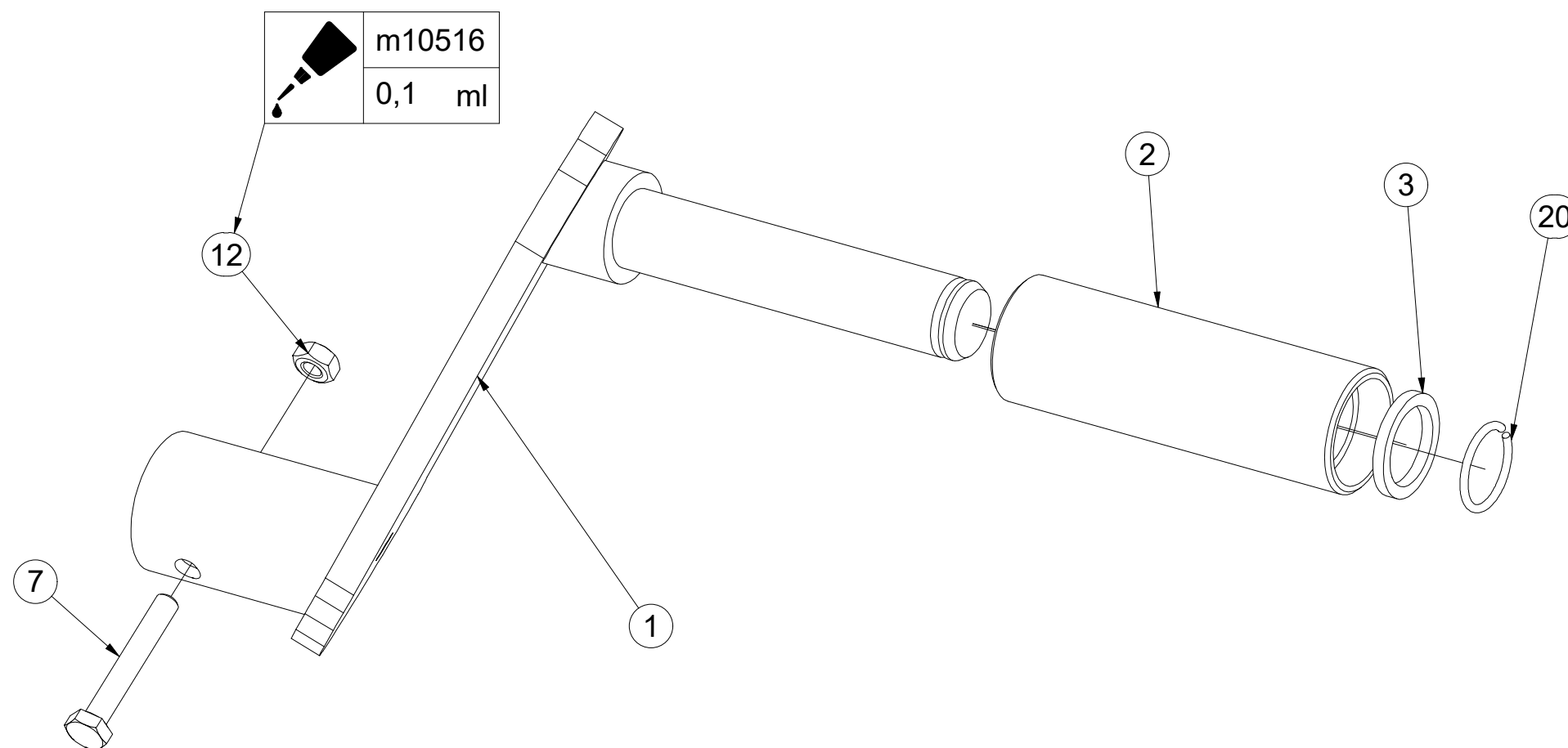

Pos.	Part Number	Pcs.
1	4003092	1
2	4001533	1
3	4004828	1
7	m04641	1
12	m01295	1
20	m06561	1
25	m10516	0,1

Ⓒ POLOTOVAR STROJE

Ⓓ MASCHINEN-HALBFABRIKAT

Ⓕ MACHINE - SEMI-PRODUIT

Ⓖ SEMIFINISHED MACHINE

Ⓡ ПОЛУФАБРИКАТ МАШИНЫ

Ⓟ PÓŁFABRYKAT MASZYN



3012671

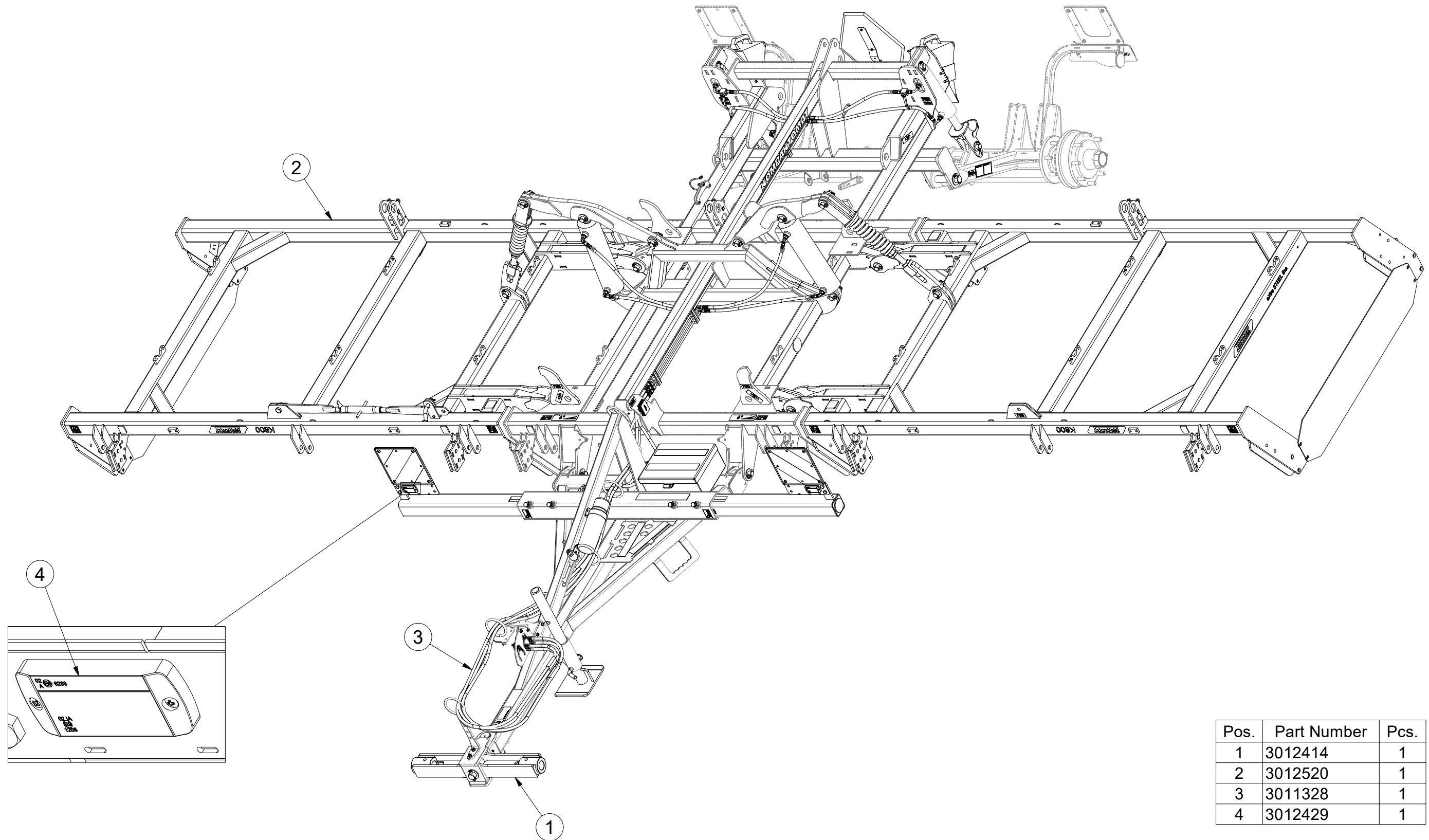

Pos.	Part Number	Pcs.
1	3012414	1
2	3012520	1
3	3011328	1
4	3012429	1

Ⓒ POLOTOVAR STROJE

Ⓓ MASCHINEN-HALBFABRIKAT

Ⓕ MACHINE - SEMI-PRODUIT

Ⓖ SEMIFINISHED MACHINE

Ⓡ ПОЛУФАБРИКАТ МАШИНЫ

Ⓢ РÓЉФАБРЫКАТ МАСЗЫНЫ



3012671

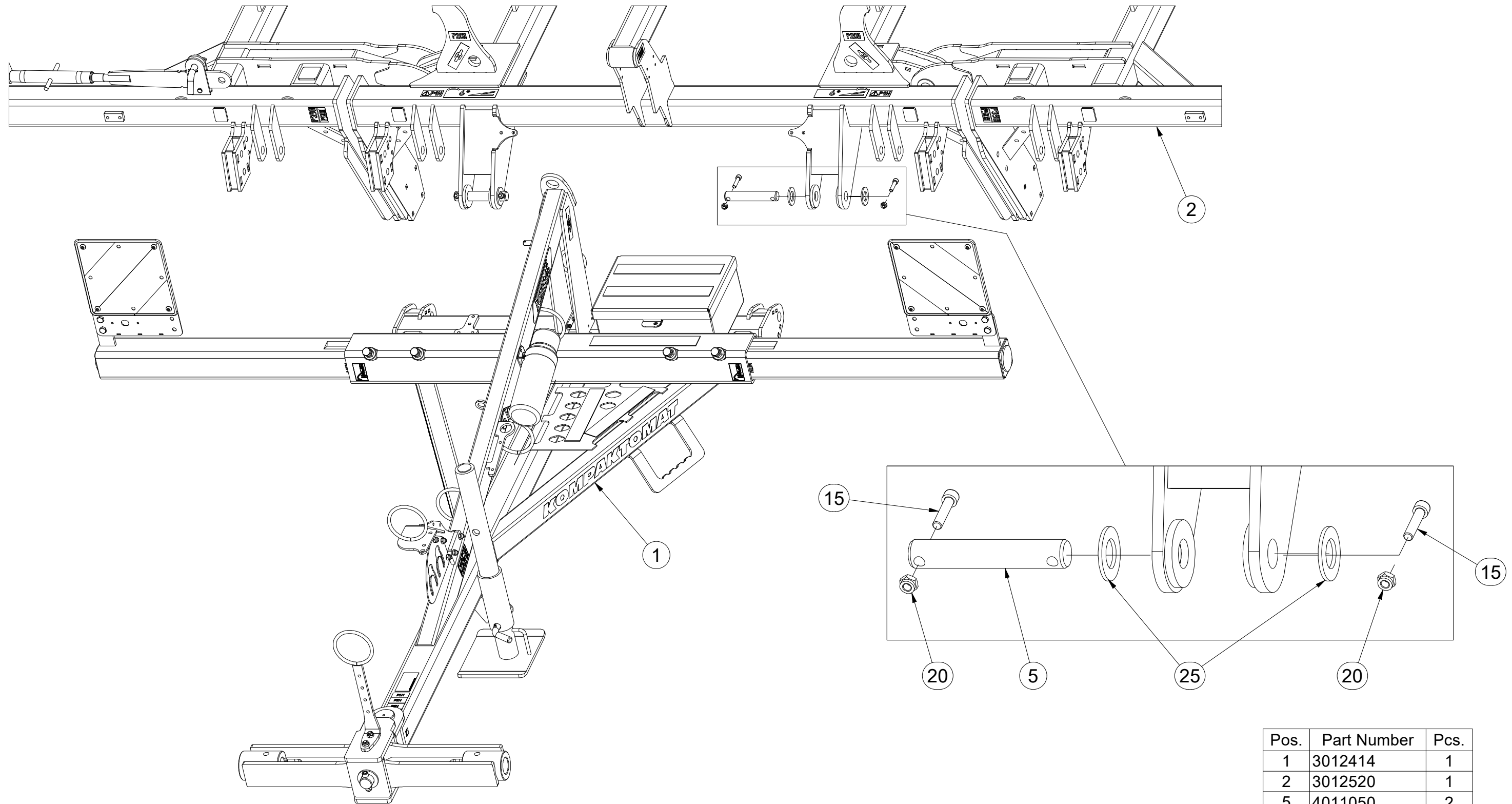

Pos.	Part Number	Pcs.
1	3012414	1
2	3012520	1
5	4011050	2
15	m14143	4
20	m03775	4
25	m14029	4

Ⓒ POLOTOVAR STROJE

Ⓓ MASCHINEN-HALBFABRIKAT

Ⓕ MACHINE - SEMI-PRODUIT

Ⓖ SEMIFINISHED MACHINE

Ⓡ ПОЛУФАБРИКАТ МАШИНЫ

Ⓟ PÓŁFABRYKAT MASZYN



3012520

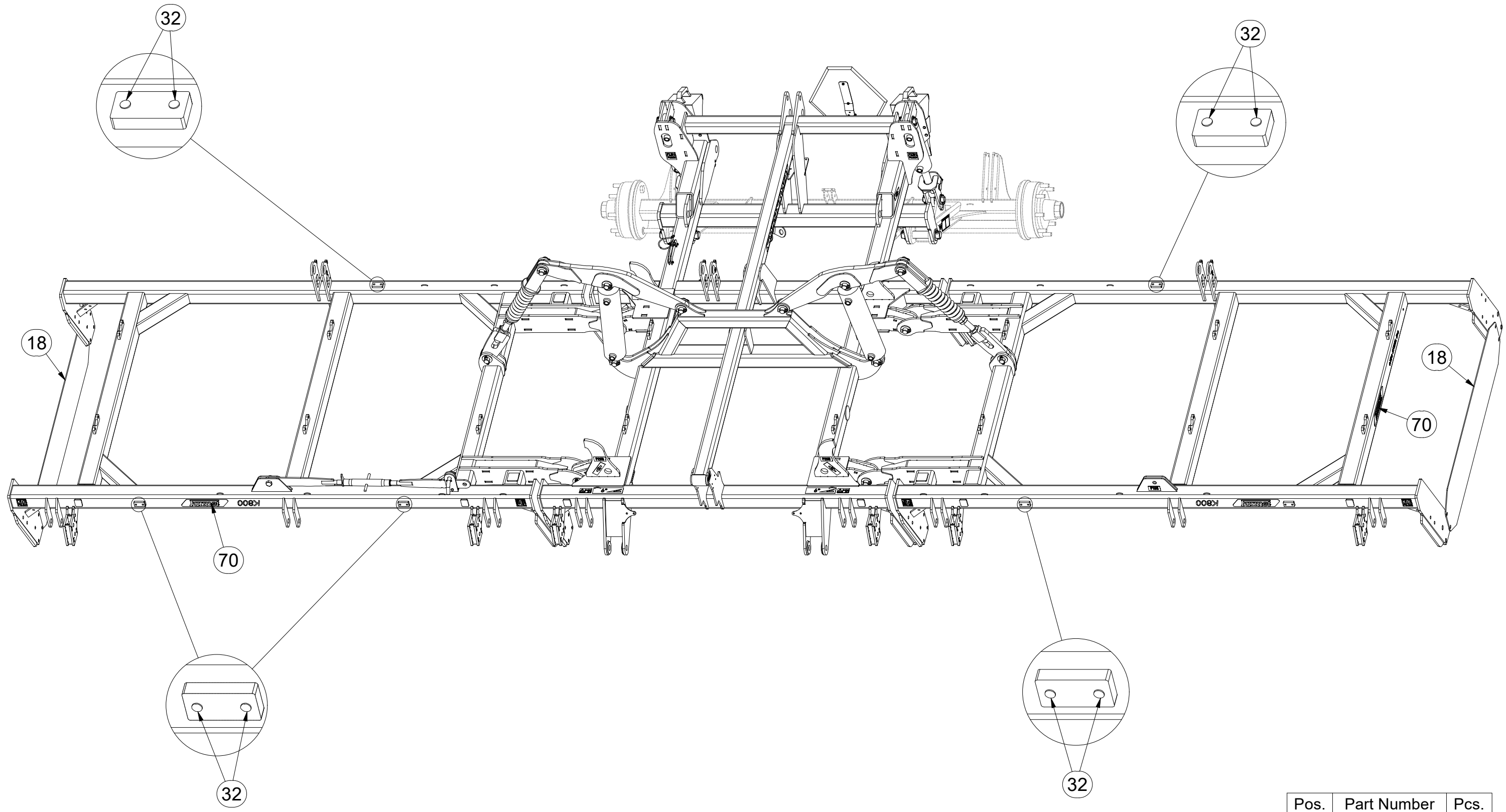

Pos.	Part Number	Pcs.
18	4005373	2
32	m11099	16
70	m19079	1

☉ POLOTOVAR STROJE

☉ MASCHINEN-HALBFABRIKAT

☉ MACHINE - SEMI-PRODUIT

☉ SEMIFINISHED MACHINE

☉ ПОЛУФАБРИКАТ МАШИНЫ

☉ PÓLFABRYKAT MASZYNY



3012520

Pos.	Part Number	Pcs.	Pos.	Part Number	Pcs.
1	2001191	1	30	m02579	2
2	6000465	1	41	m01096	1
5	4005363	2	43	m14143	36
6	4021664	2	45	m04241	1
9	4003966	1	51	m04503	9
10	4007641	4	52	m03775	36
11	4007584	2	54	m05648	1
12	4014569	2	55	m04043	2
15	4012011	1	61	m14029	36
21	m10454	2			

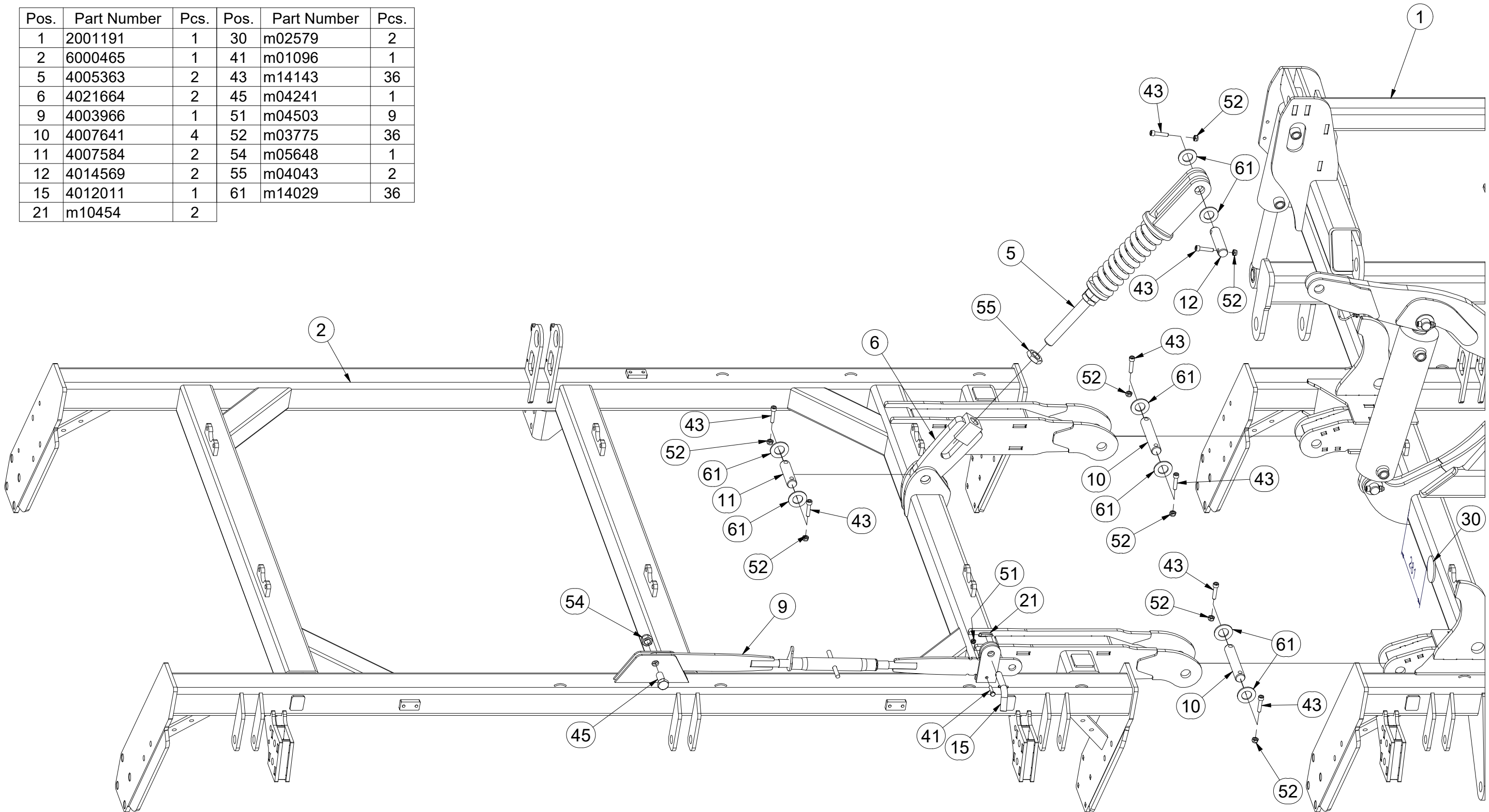

Ⓒ POLOTOVAR STROJE

Ⓓ MASCHINEN-HALBFABRIKAT

Ⓕ MACHINE - SEMI-PRODUIT

Ⓖ SEMIFINISHED MACHINE

Ⓡ ПОЛУФАБРИКАТ МАШИНЫ

Ⓟ PÓLFABRYKAT MASZYNY



3012520

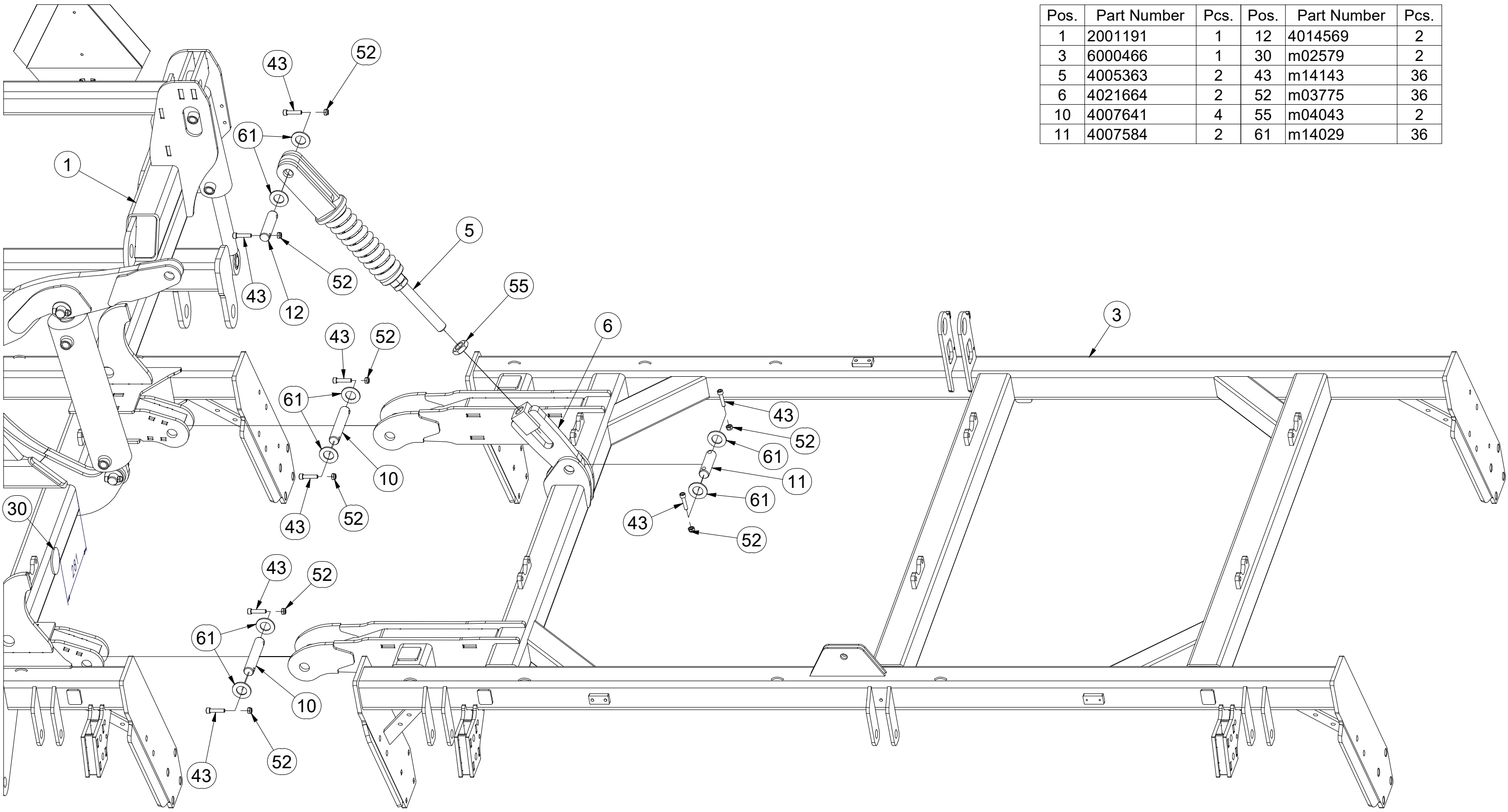

Pos.	Part Number	Pcs.	Pos.	Part Number	Pcs.
1	2001191	1	12	4014569	2
3	6000466	1	30	m02579	2
5	4005363	2	43	m14143	36
6	4021664	2	52	m03775	36
10	4007641	4	55	m04043	2
11	4007584	2	61	m14029	36

☉ POLOTOVAR STROJE

☐ MASCHINEN-HALBFABRIKAT

☉ MACHINE - SEMI-PRODUIT

☉ SEMIFINISHED MACHINE

☉ ПОЛУФАБРИКАТ МАШИНЫ

☉ PÓLFABRYKAT MASZYNY



3012520

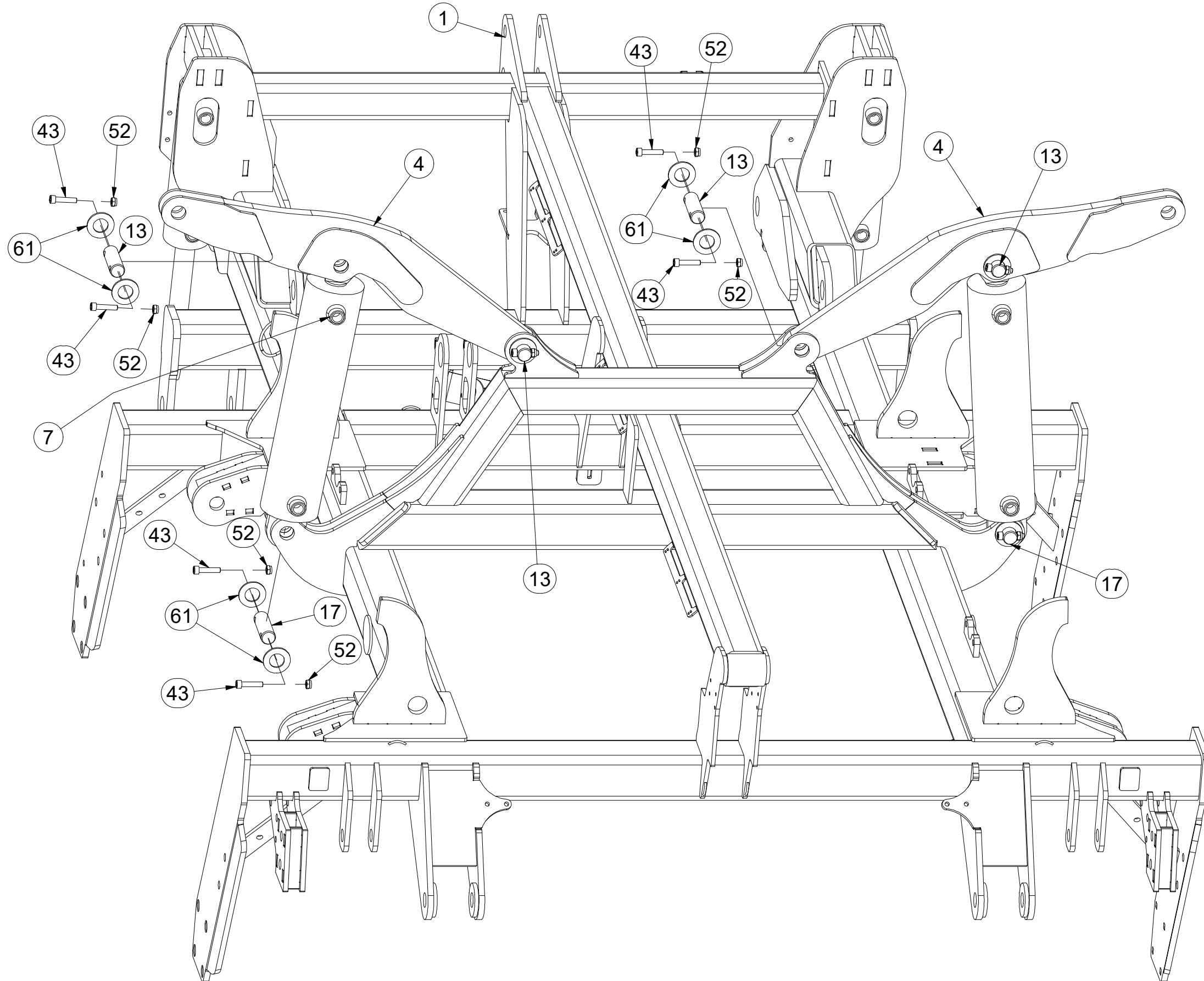

Pos.	Part Number	Pcs.
1	2001191	1
4	3002837	2
7	VZ00013004	2
13	4007640	4
17	4008234	4
43	m14143	36
52	m03775	36
61	m14029	36

☉ POLOTOVAR STROJE

☉ MASCHINEN-HALBFABRIKAT

☉ MACHINE - SEMI-PRODUIT

☉ SEMIFINISHED MACHINE

☉ ПОЛУФАБРИКАТ МАШИНЫ

☉ PÓLFABRYKAT MASZYNY



3012520

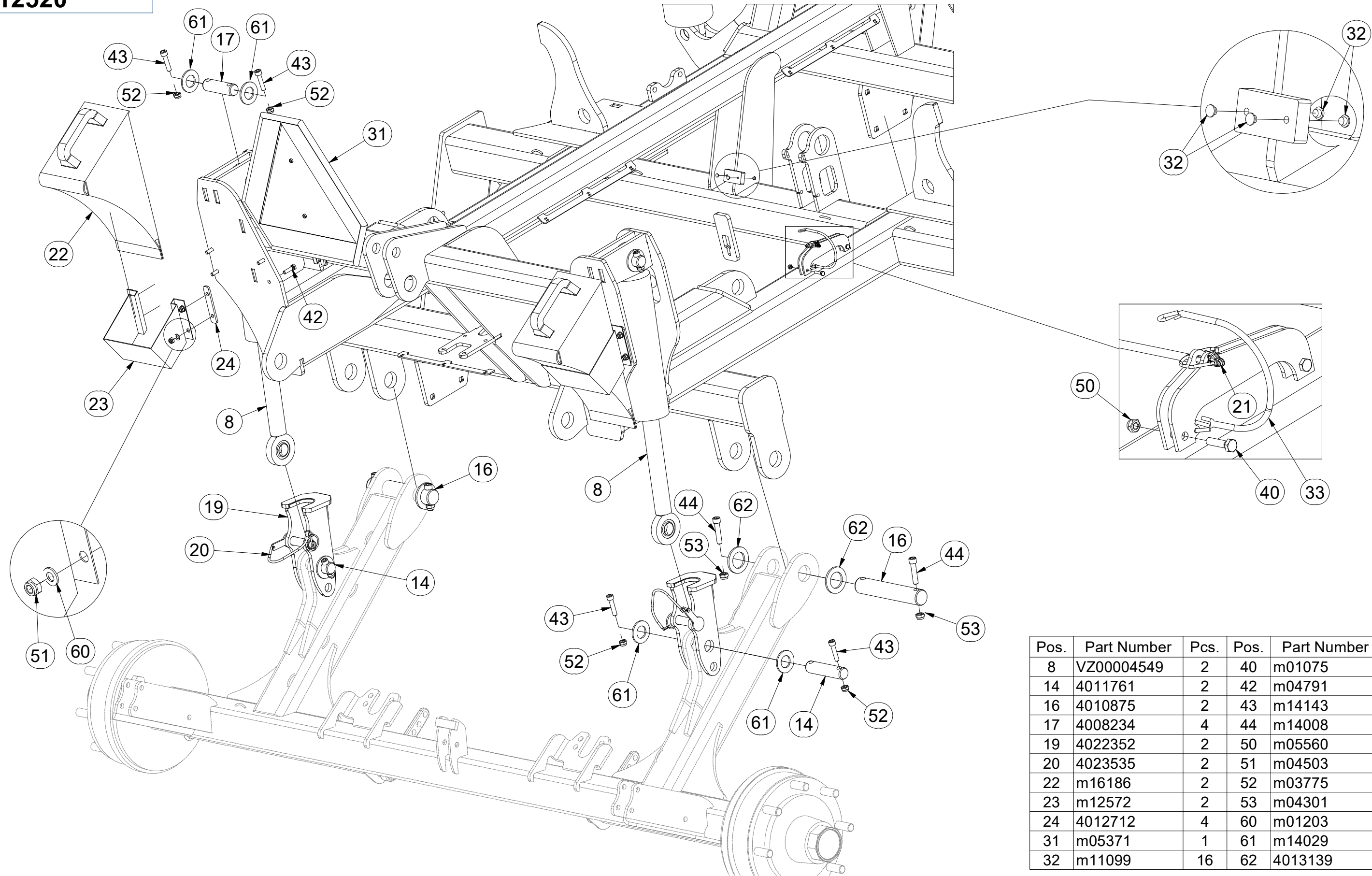

Pos.	Part Number	Pcs.	Pos.	Part Number	Pcs.
8	VZ00004549	2	40	m01075	2
14	4011761	2	42	m04791	8
16	4010875	2	43	m14143	36
17	4008234	4	44	m14008	4
19	4022352	2	50	m05560	2
20	4023535	2	51	m04503	9
22	m16186	2	52	m03775	36
23	m12572	2	53	m04301	4
24	4012712	4	60	m01203	8
31	m05371	1	61	m14029	36
32	m11099	16	62	4013139	4

ⒸZ SAMOLEPKY STROJE

Ⓓ AUFKLEBER MASCHINEN

Ⓕ VOITURE MACHINES

ⒸB STICKERS MACHINES

ⒸU СТИКЕРЫ МАШИНЫ

ⒸL NAKLEJKI MASZYNY



m19079

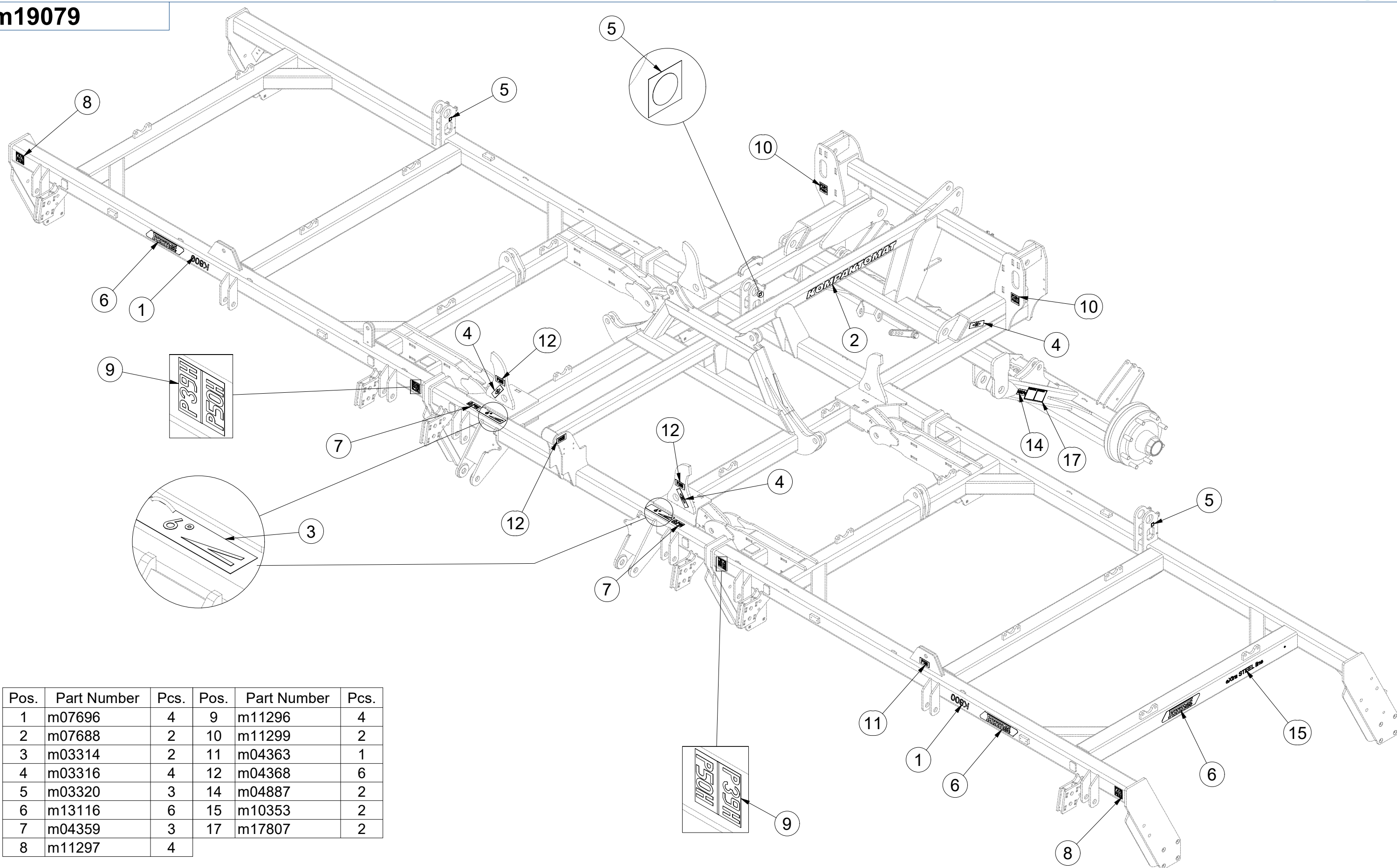

Pos.	Part Number	Pcs.	Pos.	Part Number	Pcs.
1	m07696	4	9	m11296	4
2	m07688	2	10	m11299	2
3	m03314	2	11	m04363	1
4	m03316	4	12	m04368	6
5	m03320	3	14	m04887	2
6	m13116	6	15	m10353	2
7	m04359	3	17	m17807	2
8	m11297	4			

ⒸZ SAMOLEPKY STROJE

Ⓓ AUFKLEBER MASCHINEN

Ⓕ VOITURE MACHINES

ⒸB STICKERS MACHINES

ⒸU СТИКЕРЫ МАШИНЫ

ⒸL NAKLEJKI MASZYNY



m19079

Pos.	Part Number	Pcs.	Pos.	Part Number	Pcs.
1	m07696	4	13	m14551	1
2	m07688	2	14	m04887	2
4	m03316	4	15	m10353	2
6	m13116	6	16	m13708	2
8	m11297	4	17	m17807	2
9	m11296	4	18	m03512	2
12	m04368	6			

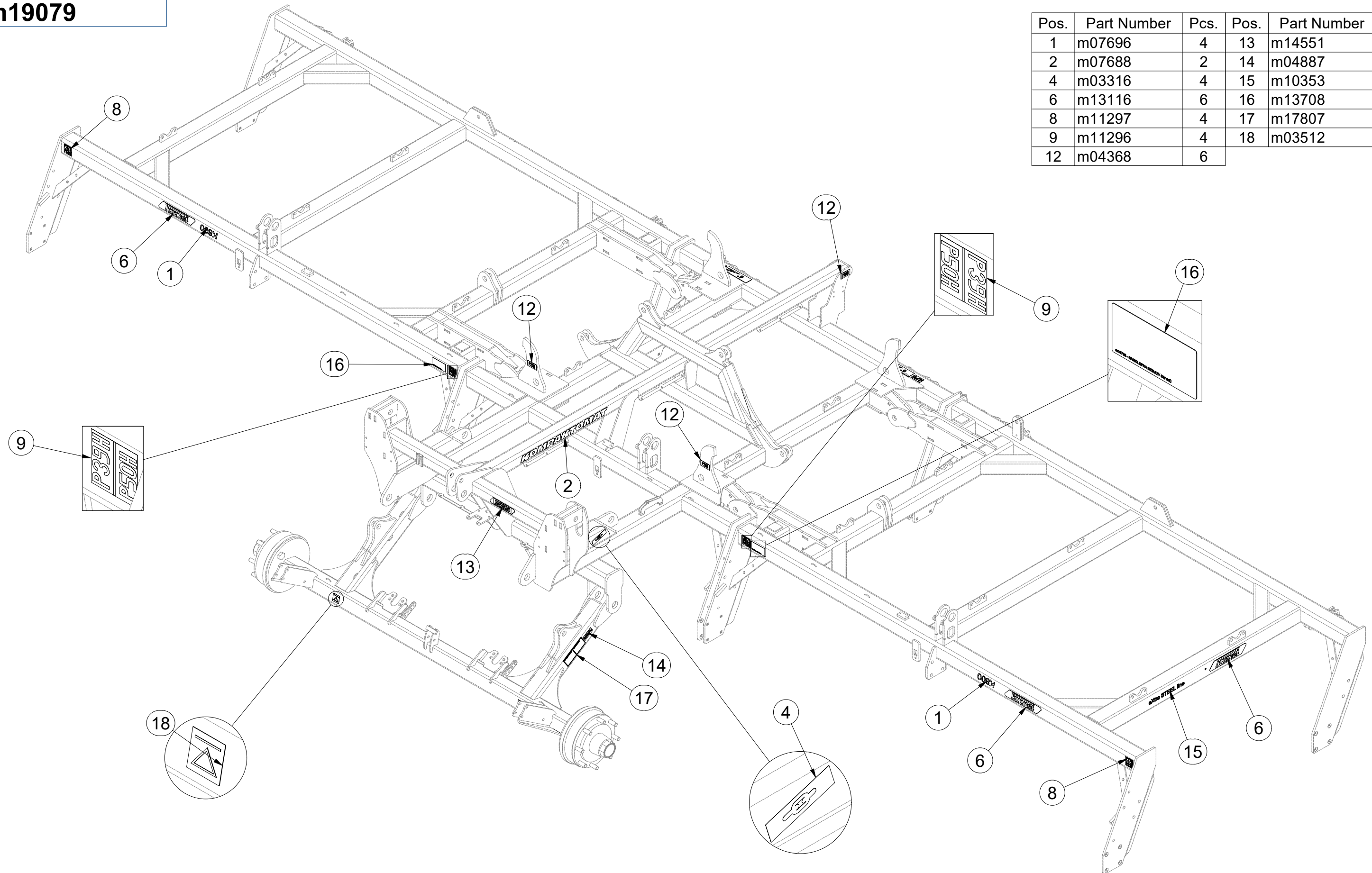

- Ⓒ CZ SADA DORAZŮ
- Ⓓ ANSCHLAGSATZ
- Ⓕ KIT DE BUTÉES

- Ⓖ GB SET OF BAR STOPS
- Ⓔ RU КОМПЛЕКТ УПОРОВ
- Ⓟ PL ZESTAW DOCISKÓW



4022352

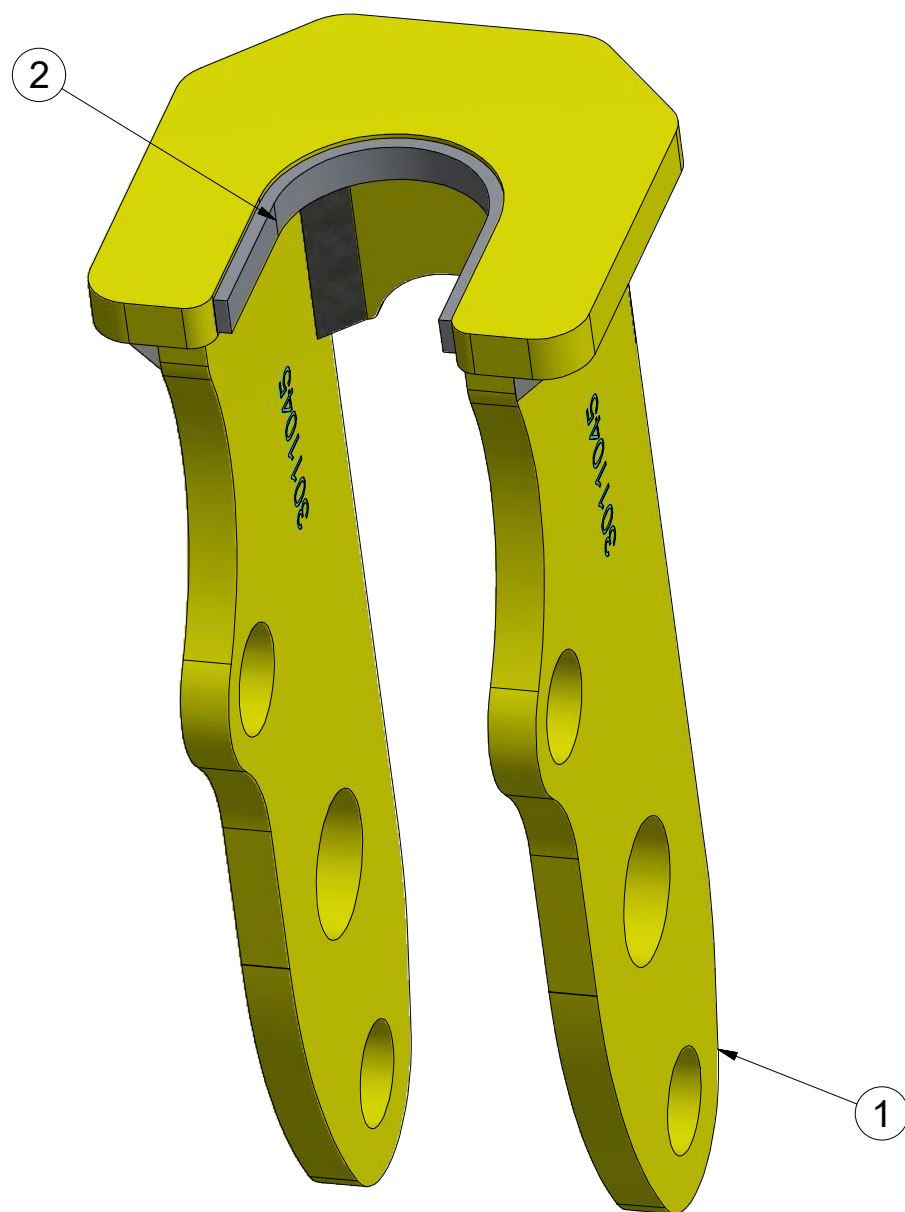

Pos.	Part Number	Pcs.
1	3011045	1
2	m09566	0,18

Ⓒ TÁHLO SKLÁPĚNÍ

Ⓓ ZUGSTANGE ZUR KIPPUNG

Ⓕ TIGES DE L'ESSIEU

Ⓒ TILTING PULL ROD

Ⓓ ТЯГИ ТРАНСПОРТНОЙ ОСИ

Ⓕ SPRZĘGI OSI

Farmet

4005363

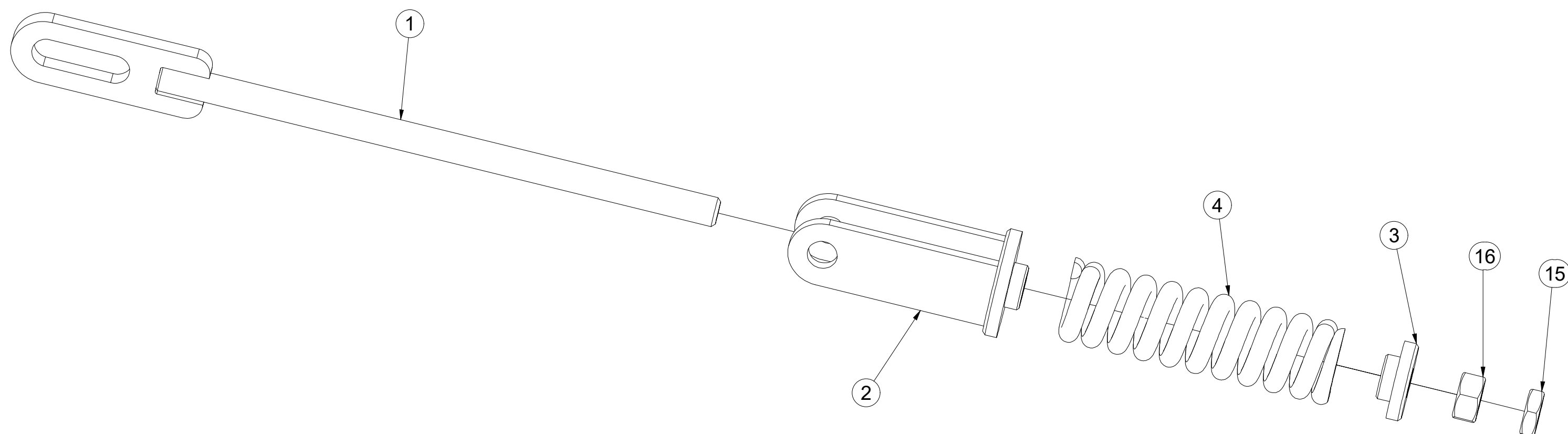
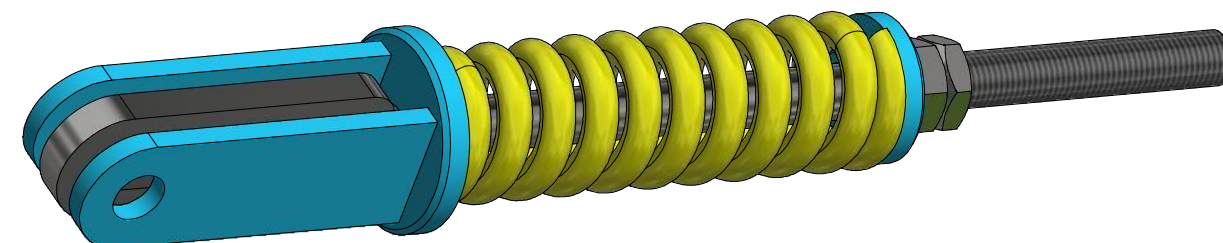

Pos.	Part Number	Pcs.
1	4005358	1
2	4005361	1
3	4000023	1
4	m06482	1
15	m04043	1
16	m01309	1

Ⓒ SPOJOVACÍ TÁHLO
Ⓓ VERBINDUNGSSTANGE
Ⓕ TIGE DE RACCORDEMENT

Ⓖ CONNECTING ROD
Ⓡ СОЕДИНИТЕЛЬНАЯ ТЯГА
Ⓟ KORBOWÓD



4003966

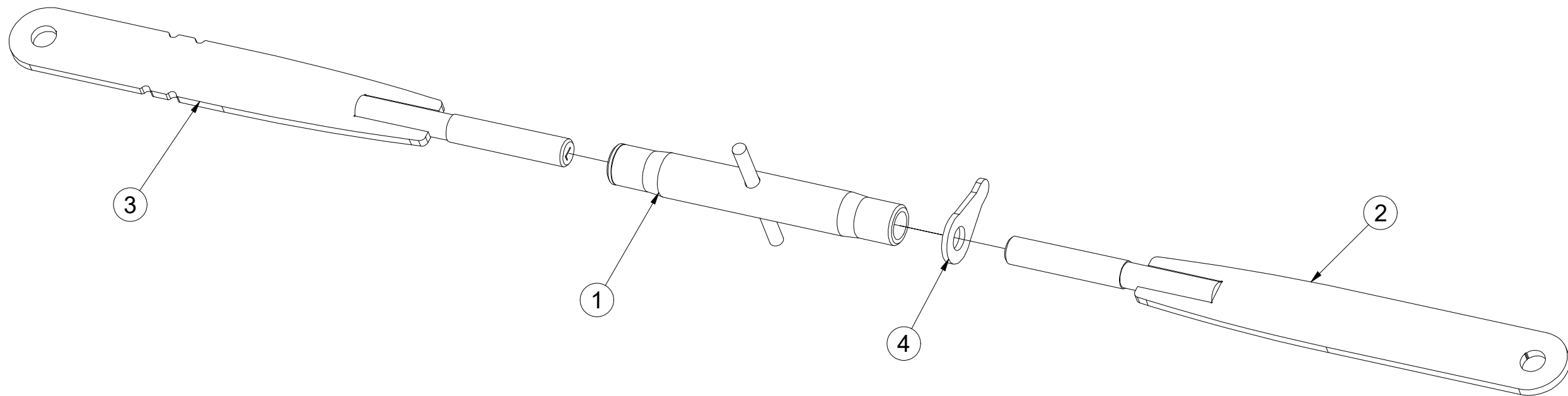
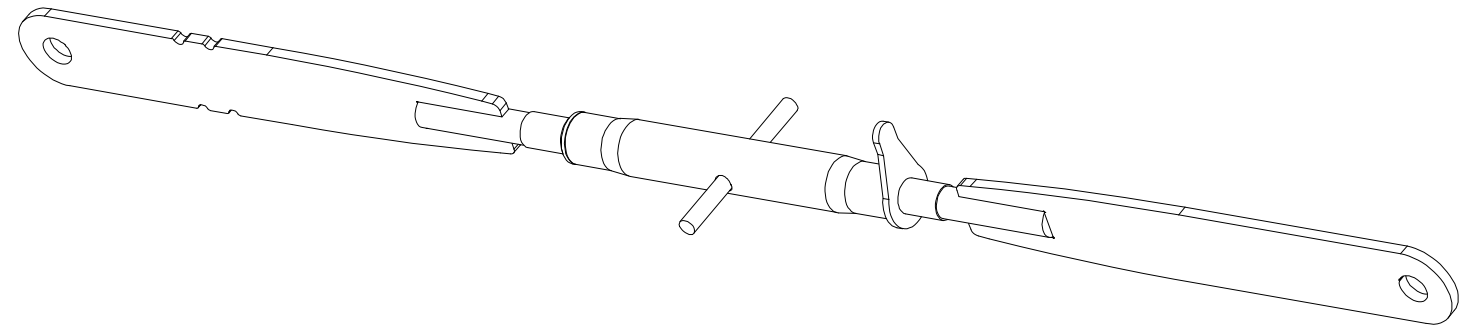

Pos.	Part Number	Pcs.
1	m08880	1
2	4023421	1
3	4023423	1
4	m08881	1

Ⓒ CZ OJ T3

Ⓓ DEICHSEL T3

Ⓕ TIMON T3

Ⓖ GB TOW BAR T3

Ⓗ RU ДЫШЛО T3

Ⓘ PL DYSZEL T3



3012414

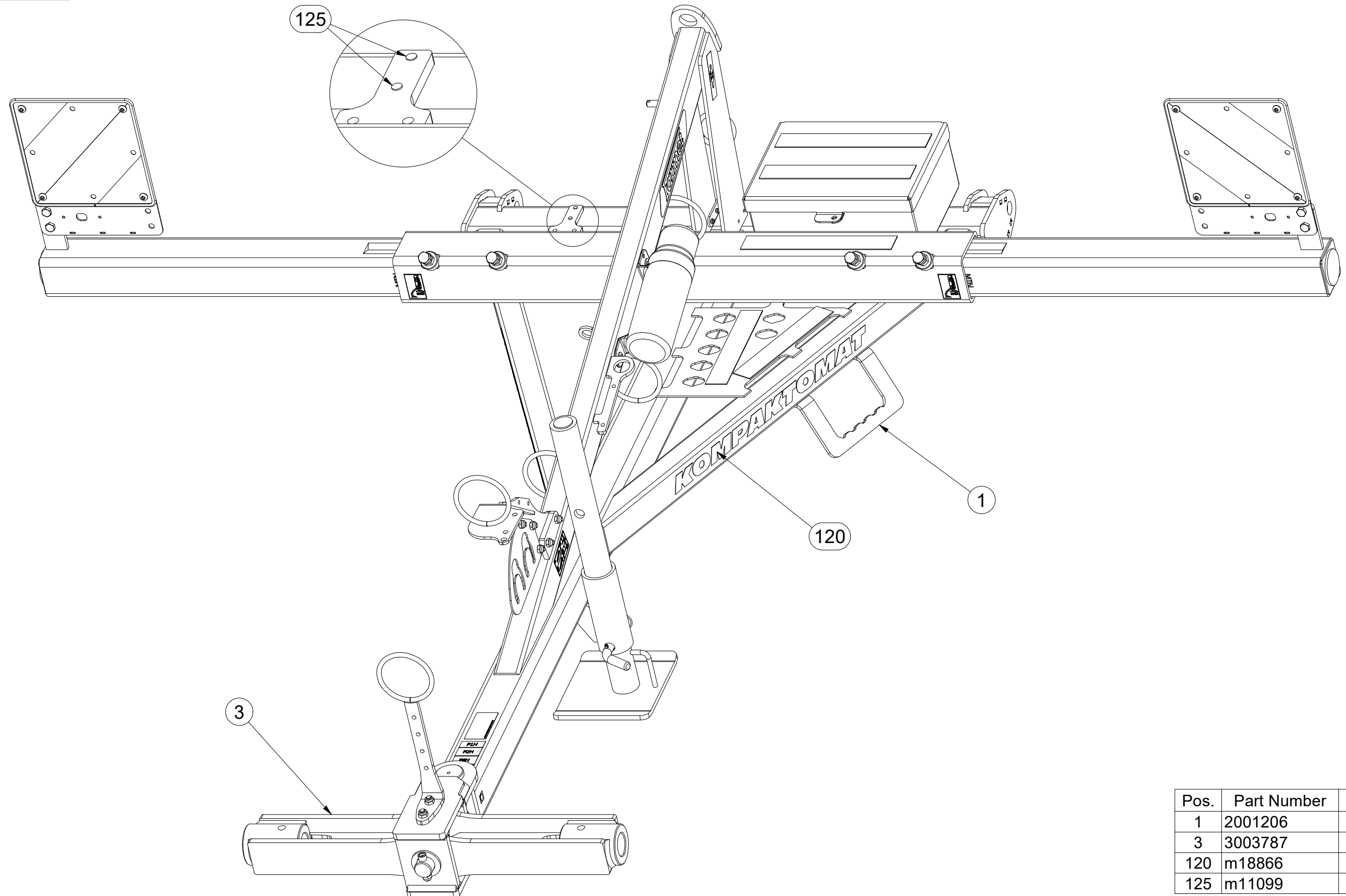

Pos.	Part Number	Pcs.
1	2001206	1
3	3003787	1
120	m18866	1
125	m11099	2

Ⓒ CZ OJ T3

Ⓓ DEICHSEL T3

Ⓕ TIMON T3

Ⓖ GB TOW BAR T3

Ⓡ RU ДЫШЛО T3

Ⓟ PL DYSZEL T3



3012414

Pos.	Part Number	Pcs.	Pos.	Part Number	Pcs.
1	2001206	1	72	m04613	2
2	3009637	1	74	m03926	2
3	3003787	1	75	m03681	3
4	4003744	2	76	m14008	2
5	4008049	1	86	m03775	5
6	4014570	1	88	m04301	8
10	8000647-40207	1	90	m02533	1
11	4012205	1	101	m03866	1
13	3012460	1	102	4013139	2
15	4019191	1	110	m10451	1
17	4008679	1	115	m03959	1
30	m10454	1			

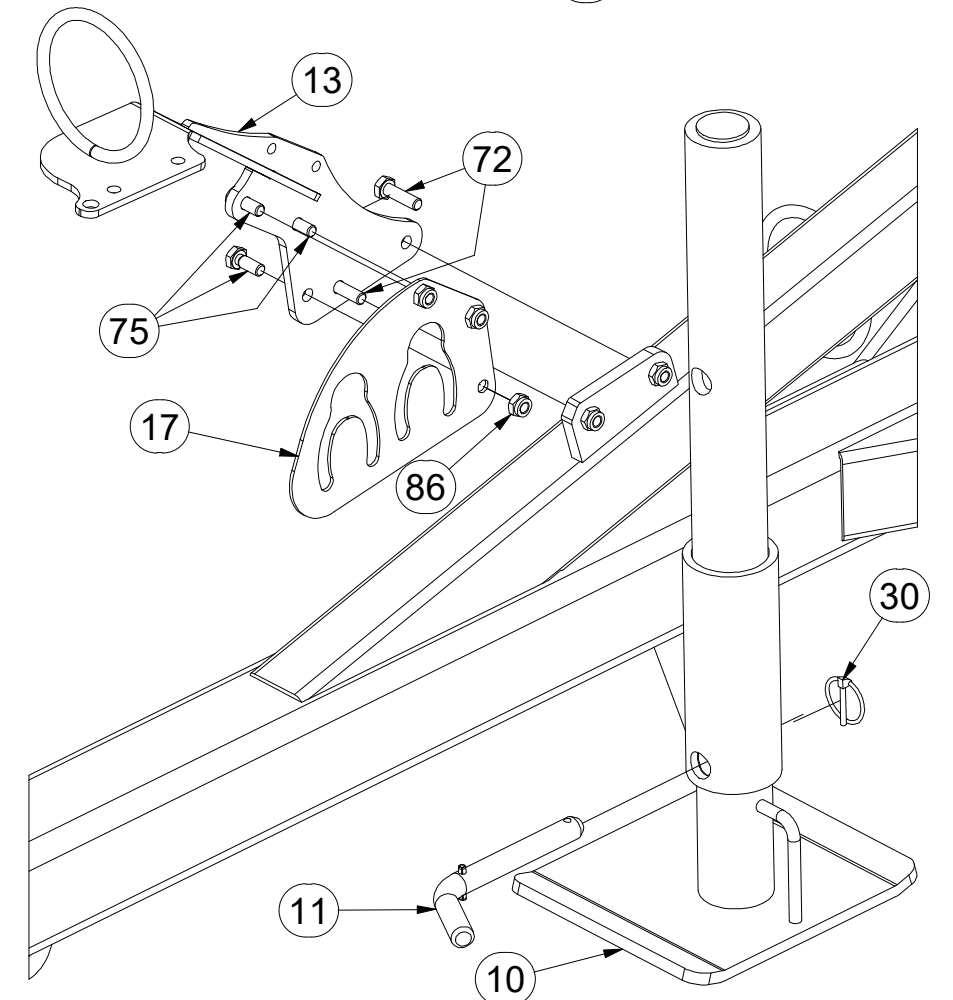
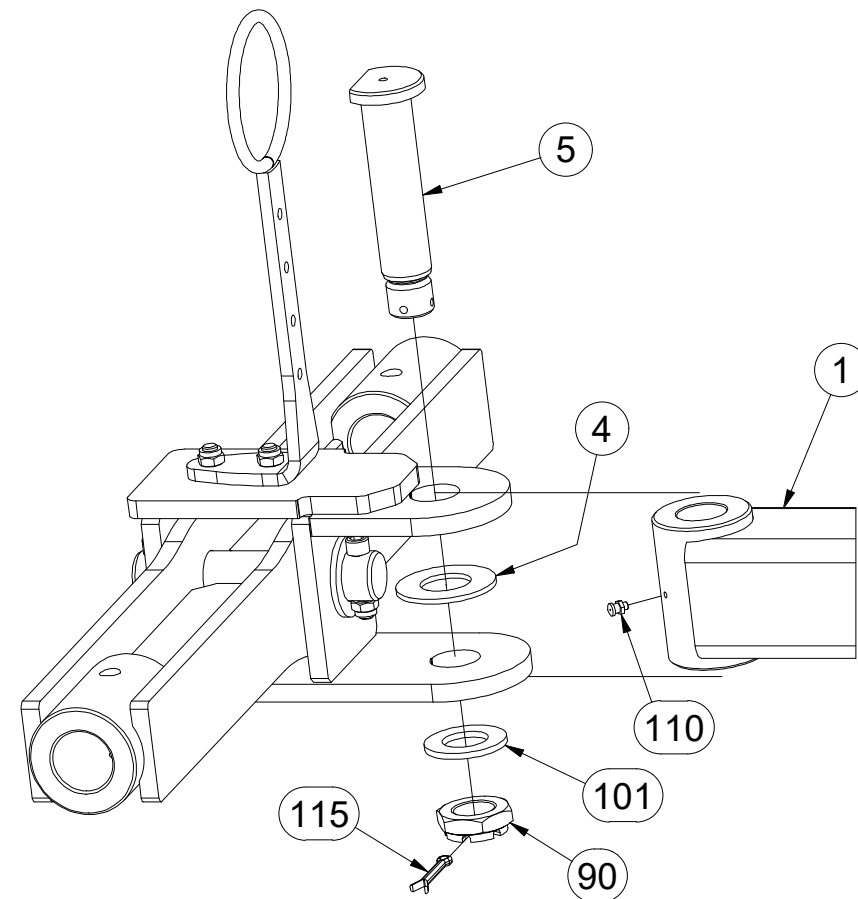
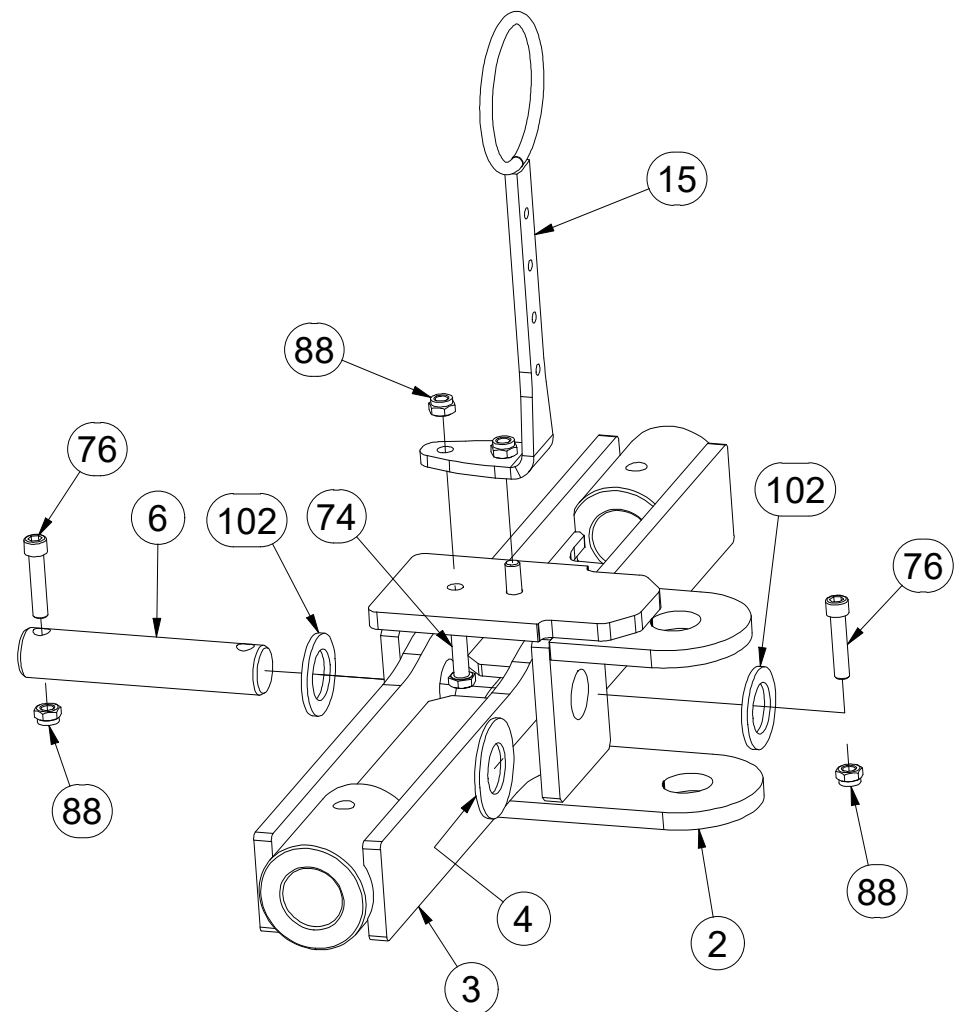
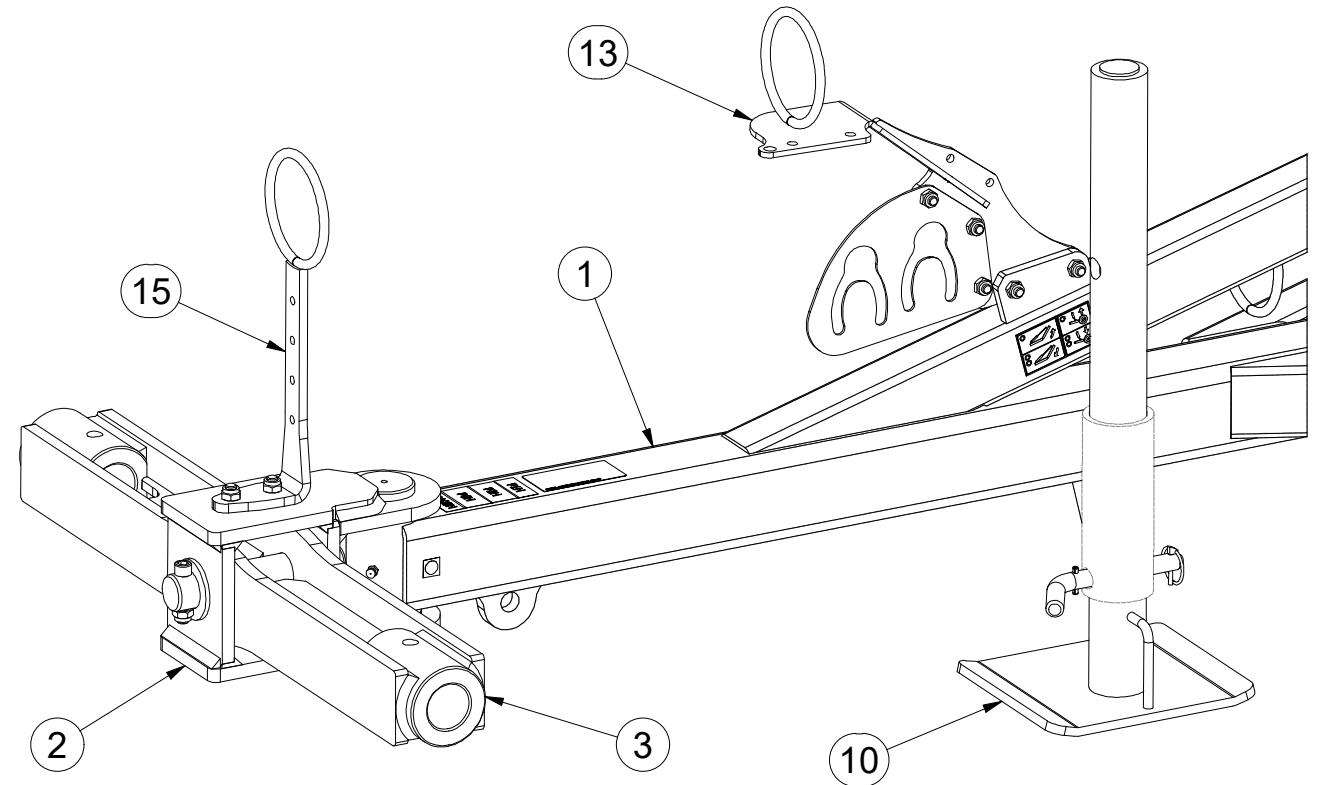

Ⓒ CZ OJ T3

Ⓓ DEICHSEL T3

Ⓕ TIMON T3

Ⓖ GB TOW BAR T3

Ⓗ RU ДЫШЛО T3

Ⓘ PL DYSZEL T3



3012414

Pos.	Part Number	Pcs.	Pos.	Part Number	Pcs.
1	2001206	1	73	m04039	4
7	4019255	2	77	m02254	4
8	4025088	1	78	m17098	2
9	4025089	1	85	m05560	4
12	m12296	1	87	m04503	3
14	4013461	1	88	m04301	8
31	m15900	1	89	m01306	4
50	m02579	2	100	m07936	3
70	m01074	2	103	m16612	4
71	m01092	3			

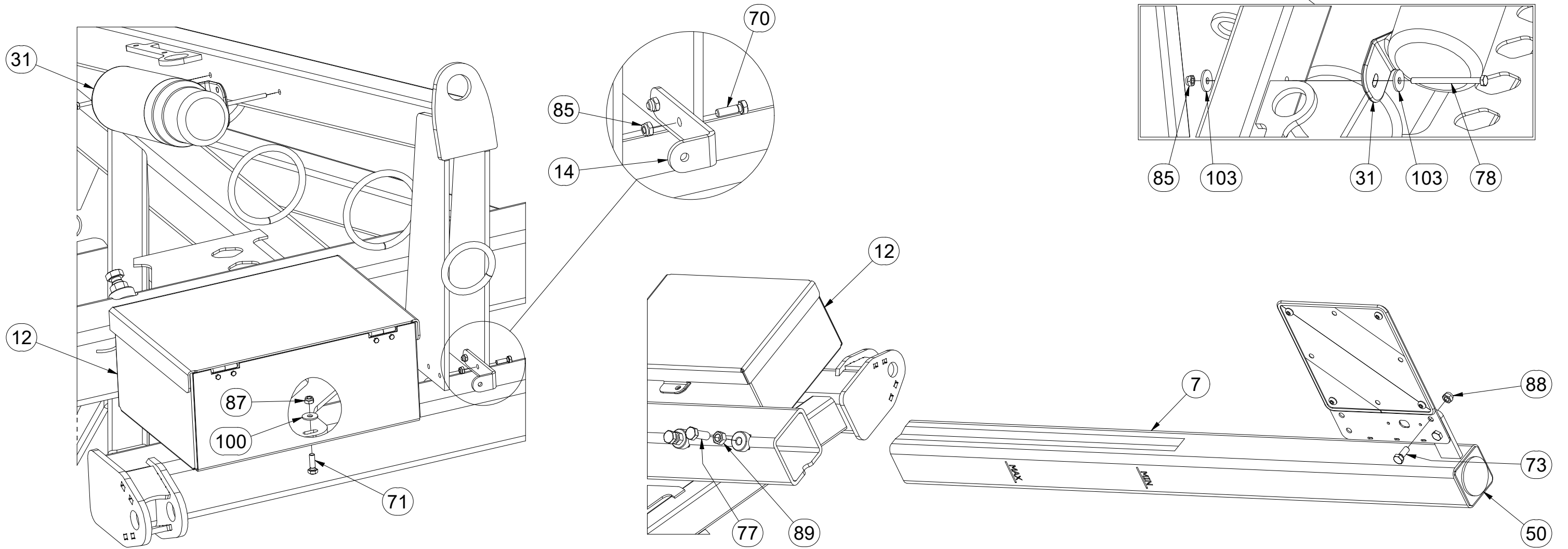
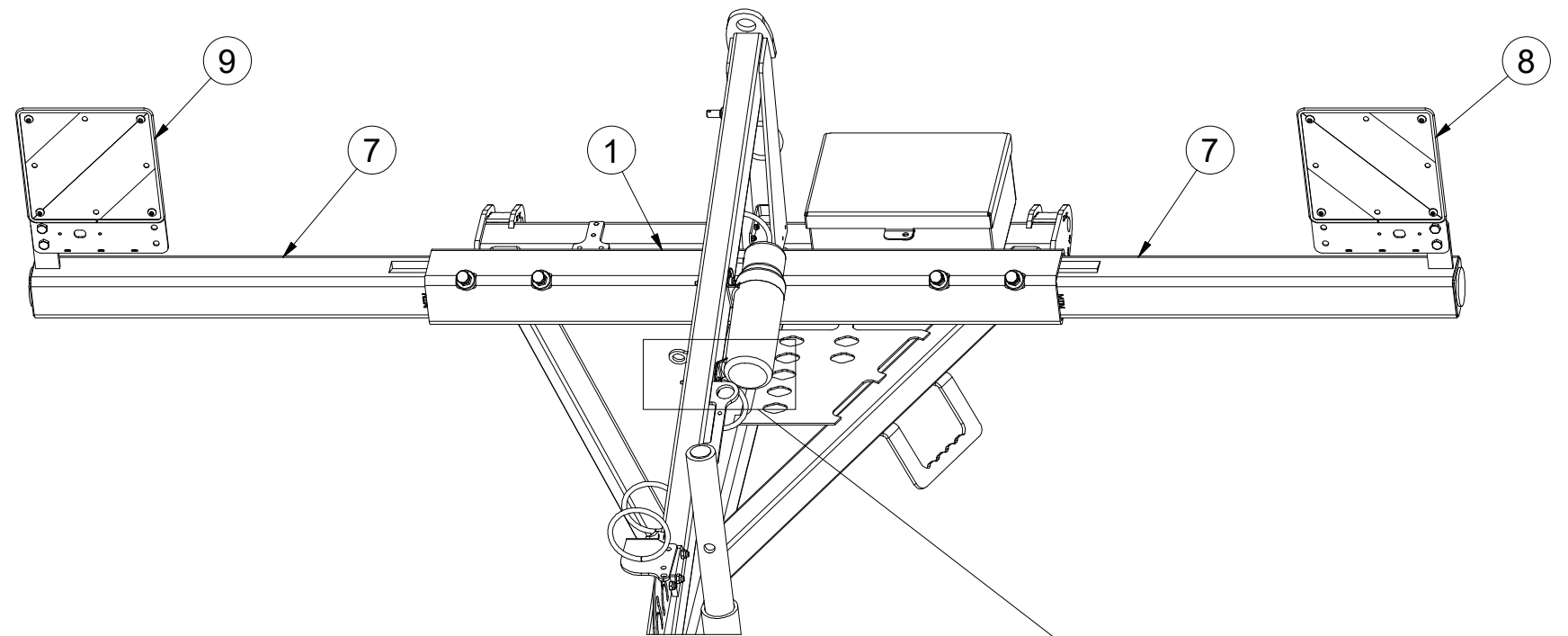

Ⓒ CZ OJ T3

Ⓓ DEICHSEL T3

Ⓕ TIMON T3

m18866

Ⓖ GB TOW BAR T3

Ⓡ RU ДЫШЛО T3

Ⓟ PL DYSZEL T3

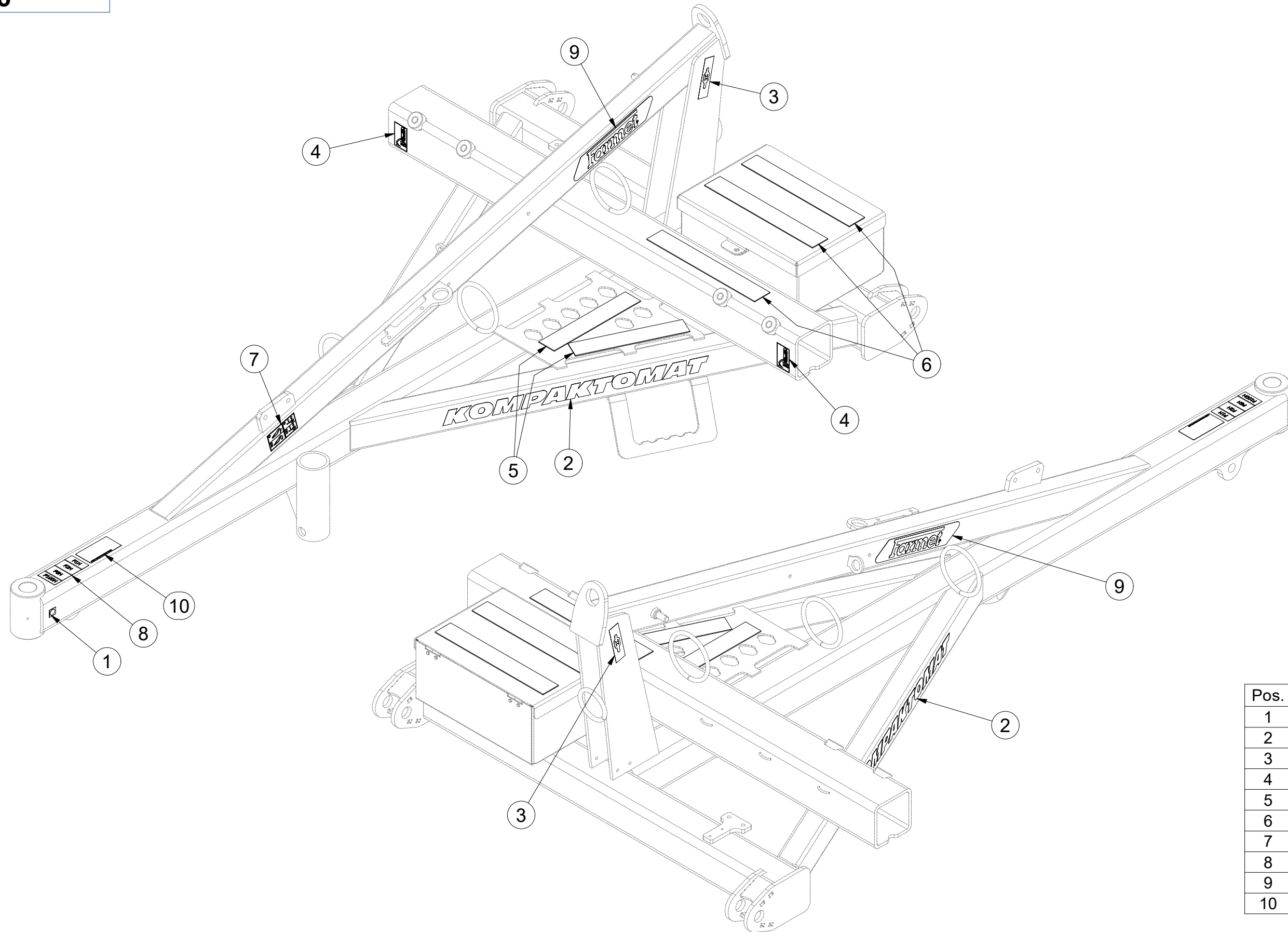

Pos.	Part Number	Pcs.
1	m03320	1
2	m07688	2
3	m03316	2
4	m10180	2
5	m11147	2
6	m11146	3
7	m11291	1
8	m11295	1
9	m13116	2
10	m13708	1

☉ SADA ČEPŮ TBZ 3

☉ BOLZENSATZ TBZ 3

☉ KIT D'EMBOUITS TBZ 3

3011605

☉ SET OF TBZ 3 PINS

☉ КОМПЛЕКТ ПАЛЬЦЕВ TBZ 3

☉ ZESTAW CZOPÓW TBZ 3

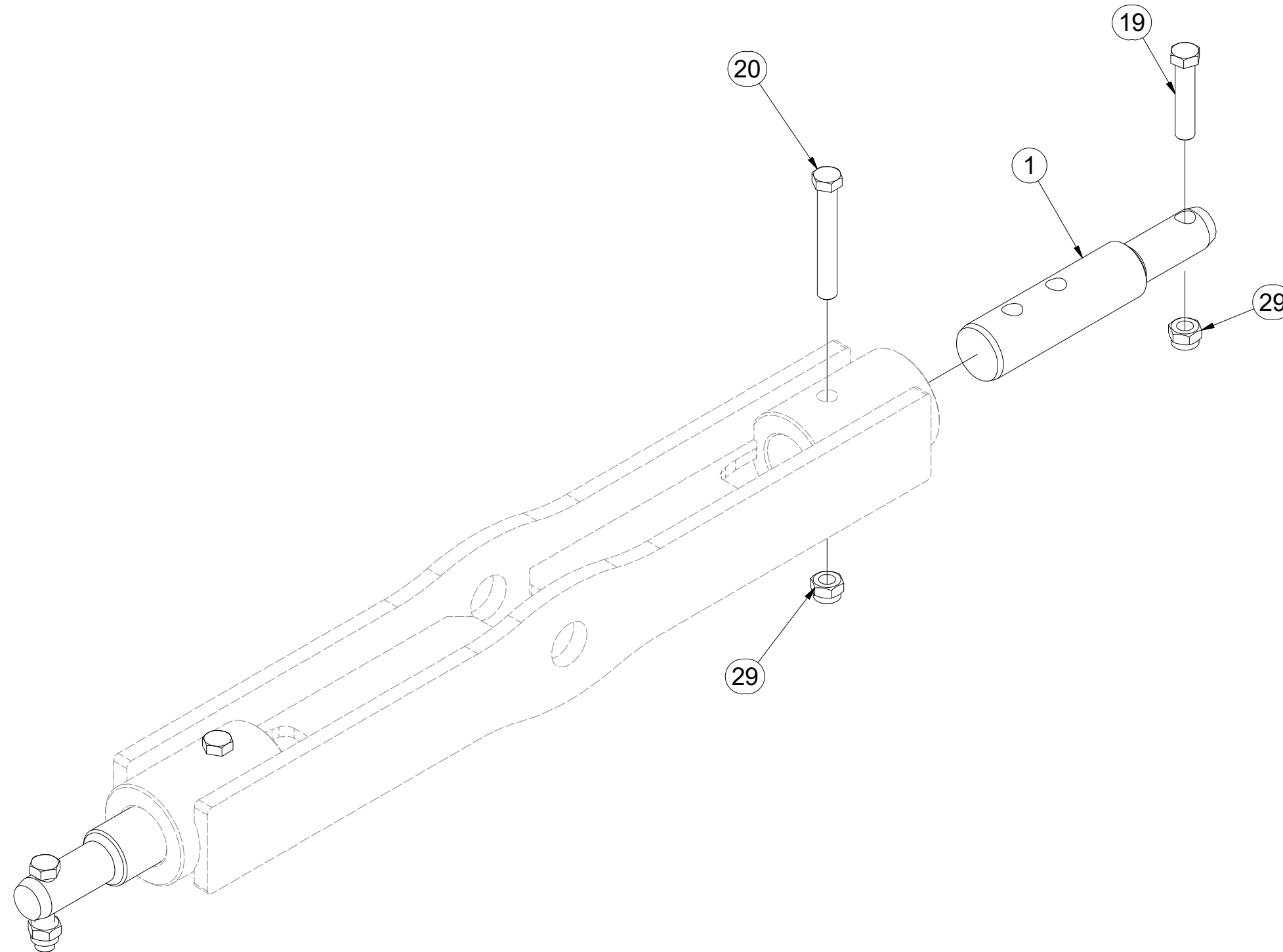
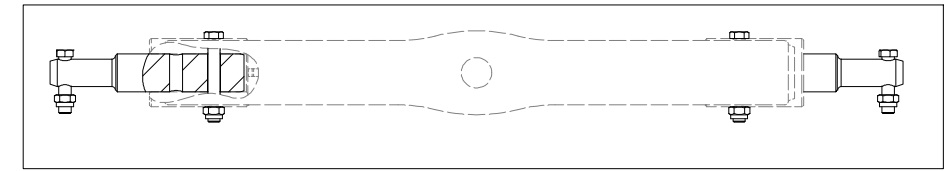

Pos.	Part Number	Pcs.
1	4023528	2
19	m01133	2
20	m02970	2
29	m03683	4

CZ TERČ PŘEDNÍ LEVÝ
 D SCHILD, VORDERES, LINKES
 F CIBLE AVANT GAUCHE

GB LEFT FRONT DISC
 RU ЩИТОК ПЕРЕДНИЙ ЛЕВЫЙ
 PL TARCZA PRZEDNIA LEWA



4025088

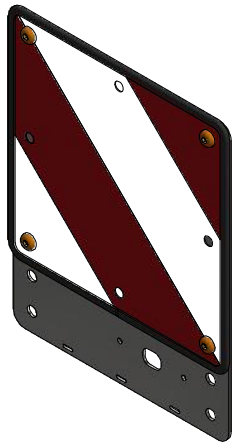
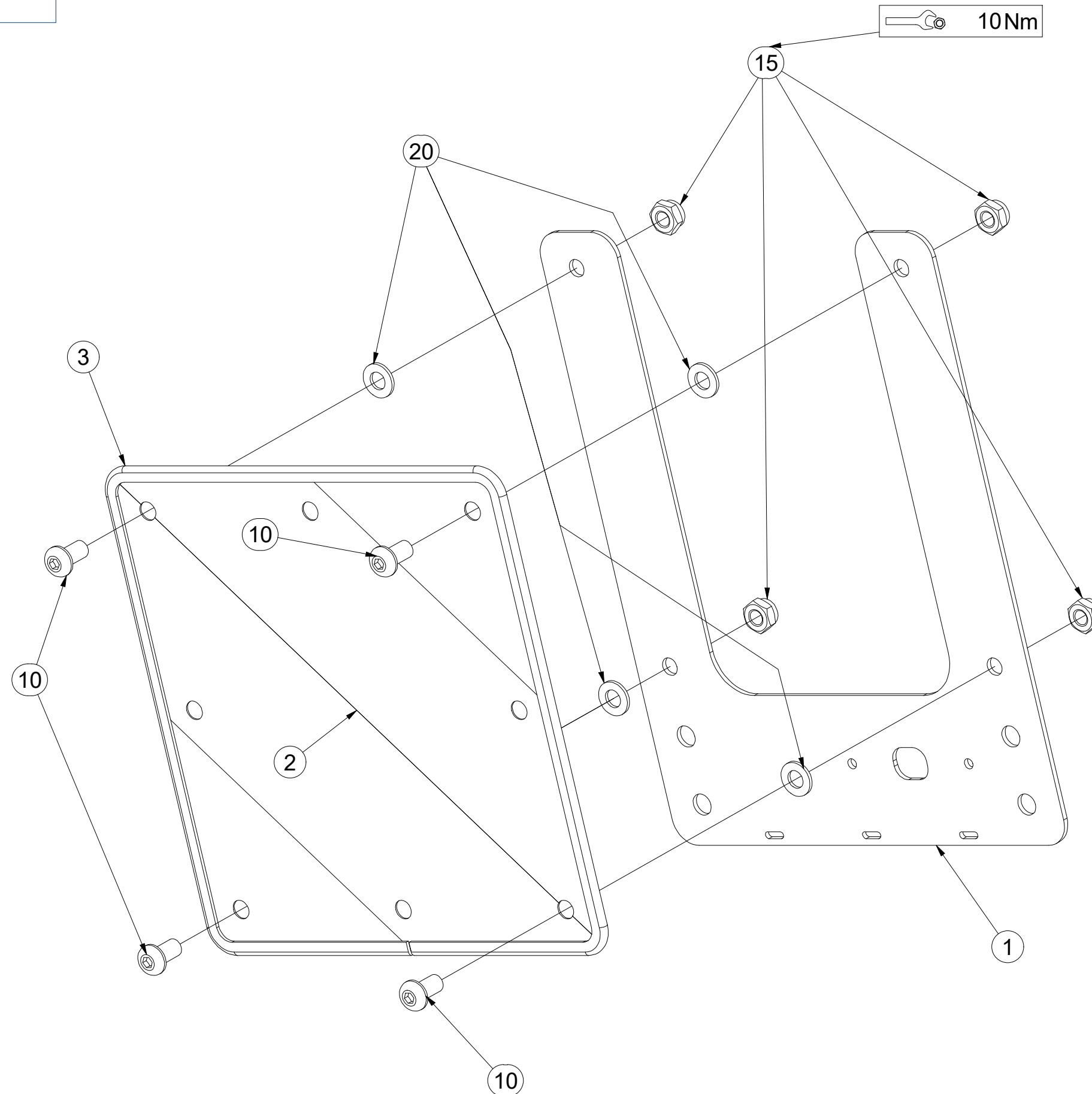

Pos.	Part Number	Pcs.
1	4025090	1
2	m18855	1
3	9005707	1
10	m16637	4
15	m03775	4
20	m01209	4

ⒸZ TERČ PŘEDNÍ PREVÝ

Ⓓ SCHILD, VORDERES, RECHTES

Ⓕ CIBLE AVANT DROITE

ⒼB RIGHT FRONT DISC

ⒶU ЩИТОК ПЕРЕДНИЙ ПРАВЫЙ

ⒶL TARCZA PRZEDNIA PRAWA



4025089

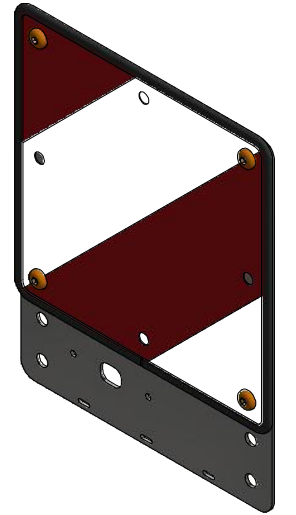
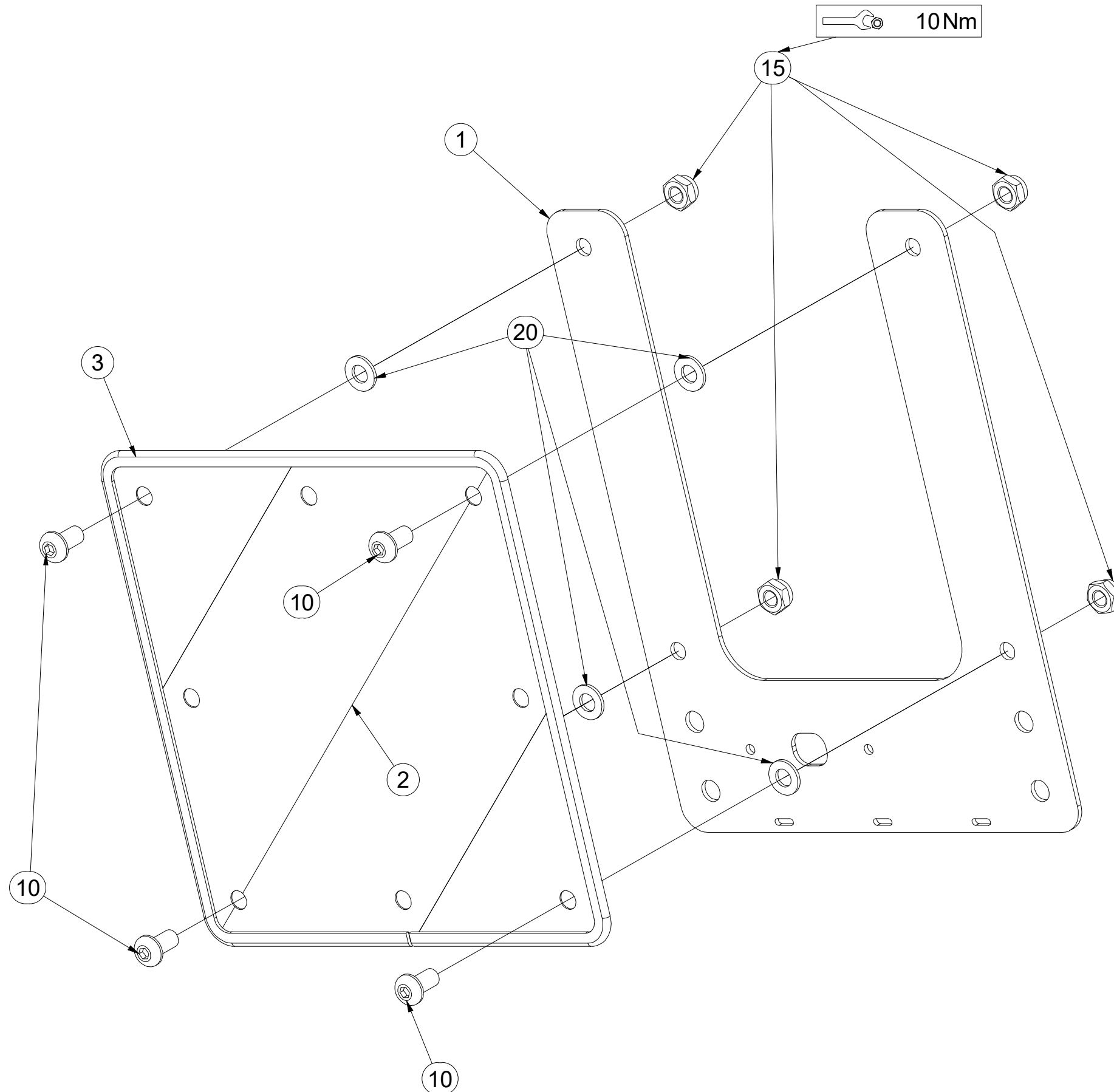

Pos.	Part Number	Pcs.
1	4025090	1
2	m18855	1
3	9005707	1
10	m16637	4
15	m03775	4
20	m01209	4

Ⓒ HYDRAULIKA STROJE
Ⓓ HYDRAULIK DER MASCHINE
Ⓕ HYDRAULIQUE DE LA MACHINE

Ⓖ MACHINE HYDRAULICS
Ⓡ ГИДРАВЛИКА МАШИНЫ
Ⓣ HYDRAULIKA MASZYN



3011328

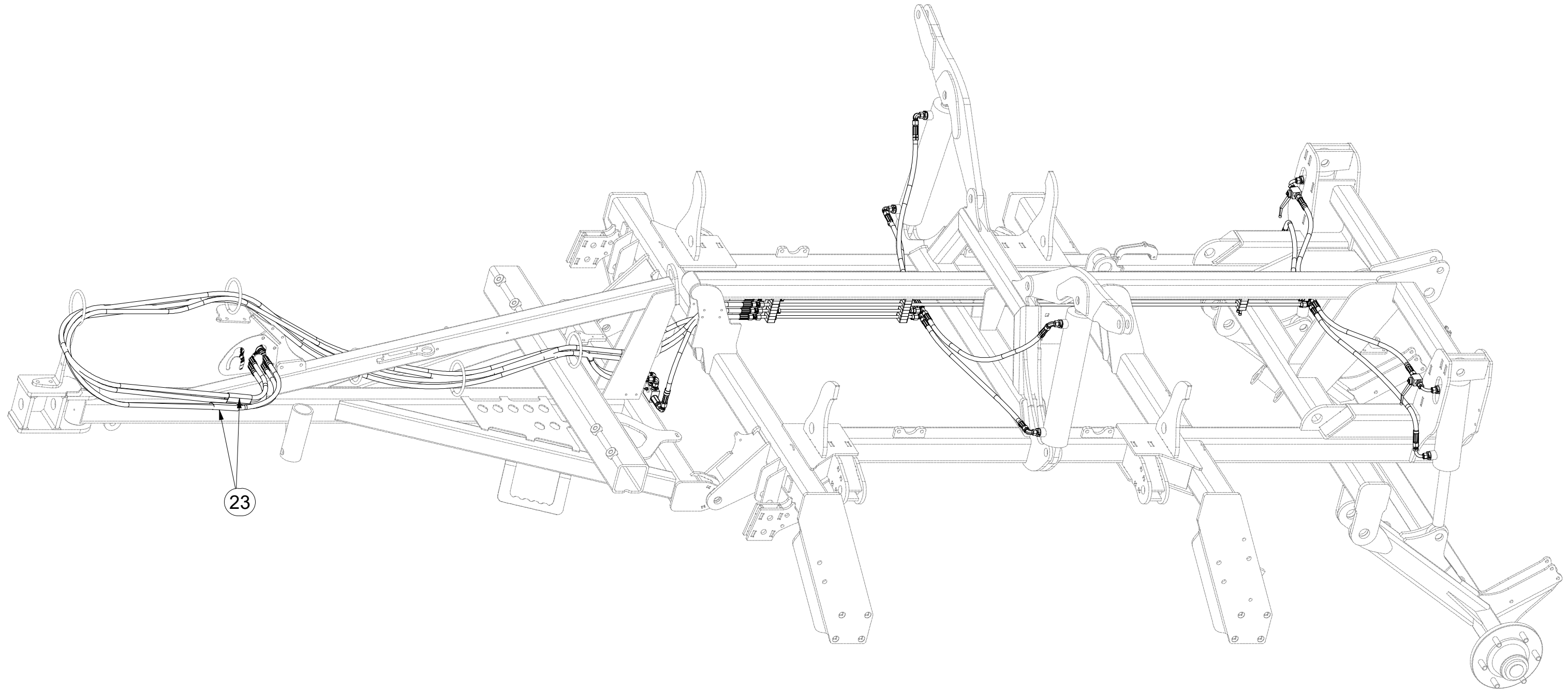

Pos.	Part Number	Pcs.
23	m11183	2

ⒸZ HYDRAULIKA STROJE

Ⓓ HYDRAULIK DER MASCHINE

Ⓕ HYDRAULIQUE DE LA MACHINE

ⒼB MACHINE HYDRAULICS

Ⓔ RU ГИДРАВЛИКА МАШИНЫ

Ⓗ PL HYDRAULIKA MASZYN



3011328

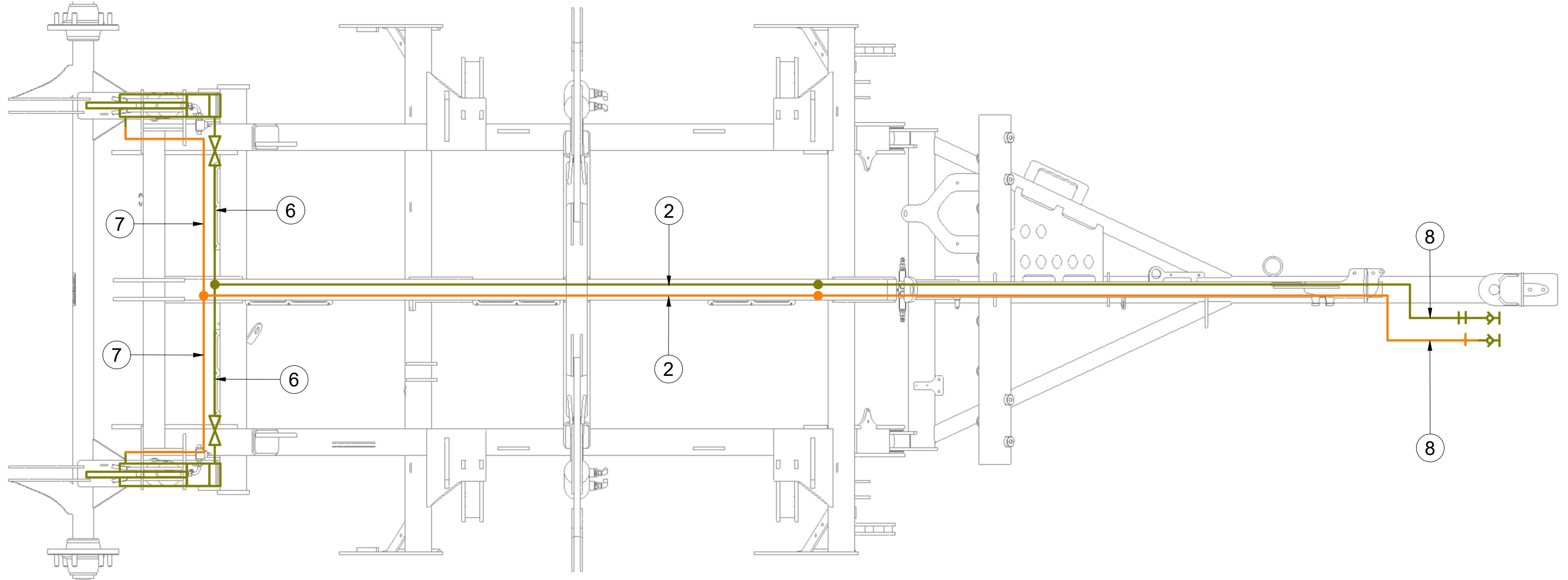

Pos.	Part Number	Pcs.
2	m04803	2
6	m03713	4
7	m04033	2
8	m09431	2

ⒸZ HYDRAULIKA STROJE

Ⓓ HYDRAULIK DER MASCHINE

Ⓕ HYDRAULIQUE DE LA MACHINE

ⒸB MACHINE HYDRAULICS

ⒸR ГИДРАВЛИКА МАШИНЫ

ⒸL HYDRAULIKA MASZYNY



3011328

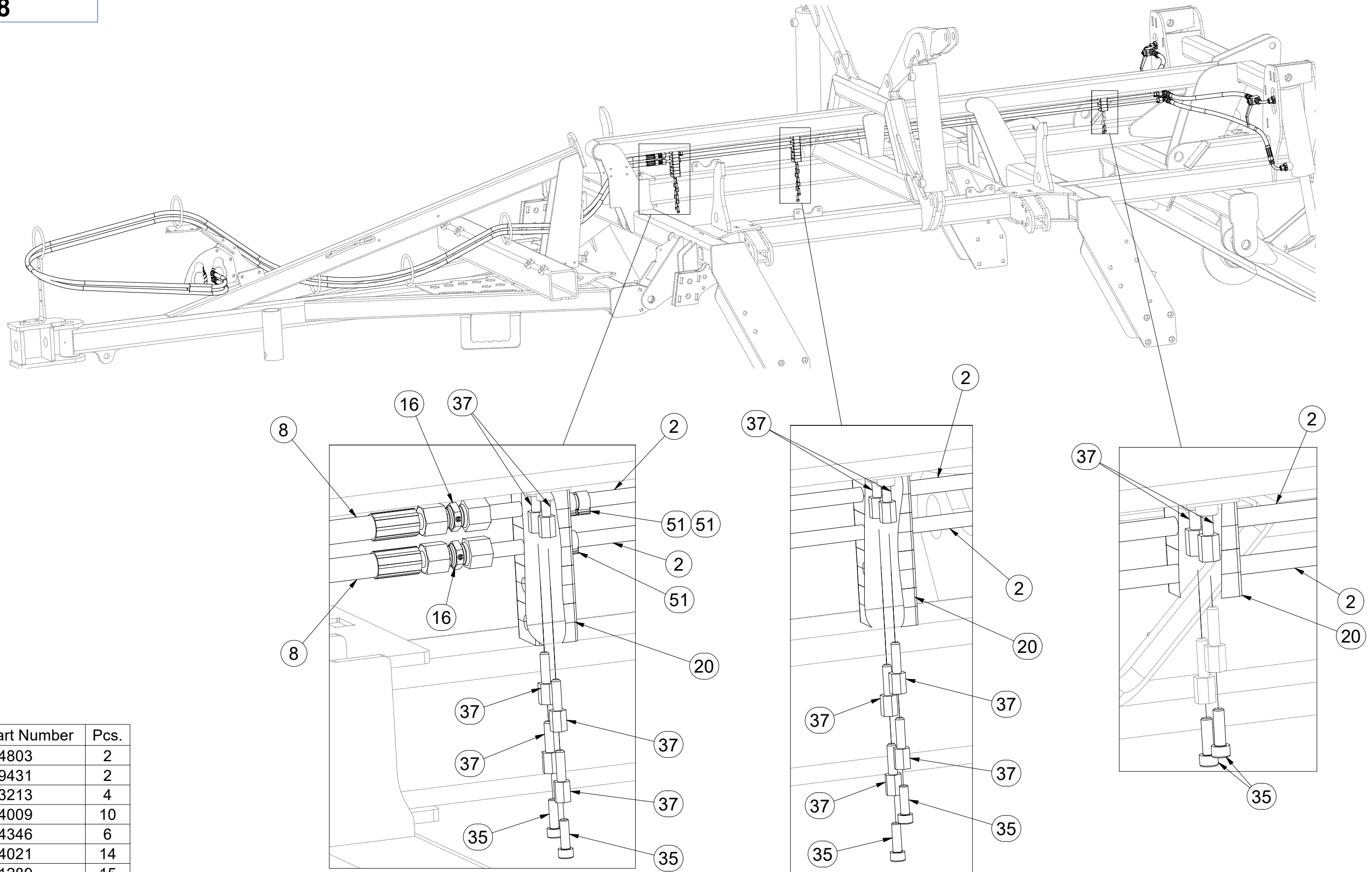

Pos.	Part Number	Pcs.
2	m04803	2
8	m09431	2
16	m03213	4
20	m04009	10
35	m04346	6
37	m04021	14
51	m11289	15

ⒸZ HYDRAULIKA STROJE

Ⓓ HYDRAULIK DER MASCHINE

Ⓕ HYDRAULIQUE DE LA MACHINE

ⒼB MACHINE HYDRAULICS

Ⓔ RU ГИДРАВЛИКА МАШИНЫ

ⒼL HYDRAULIKA MASZYNY



3011328

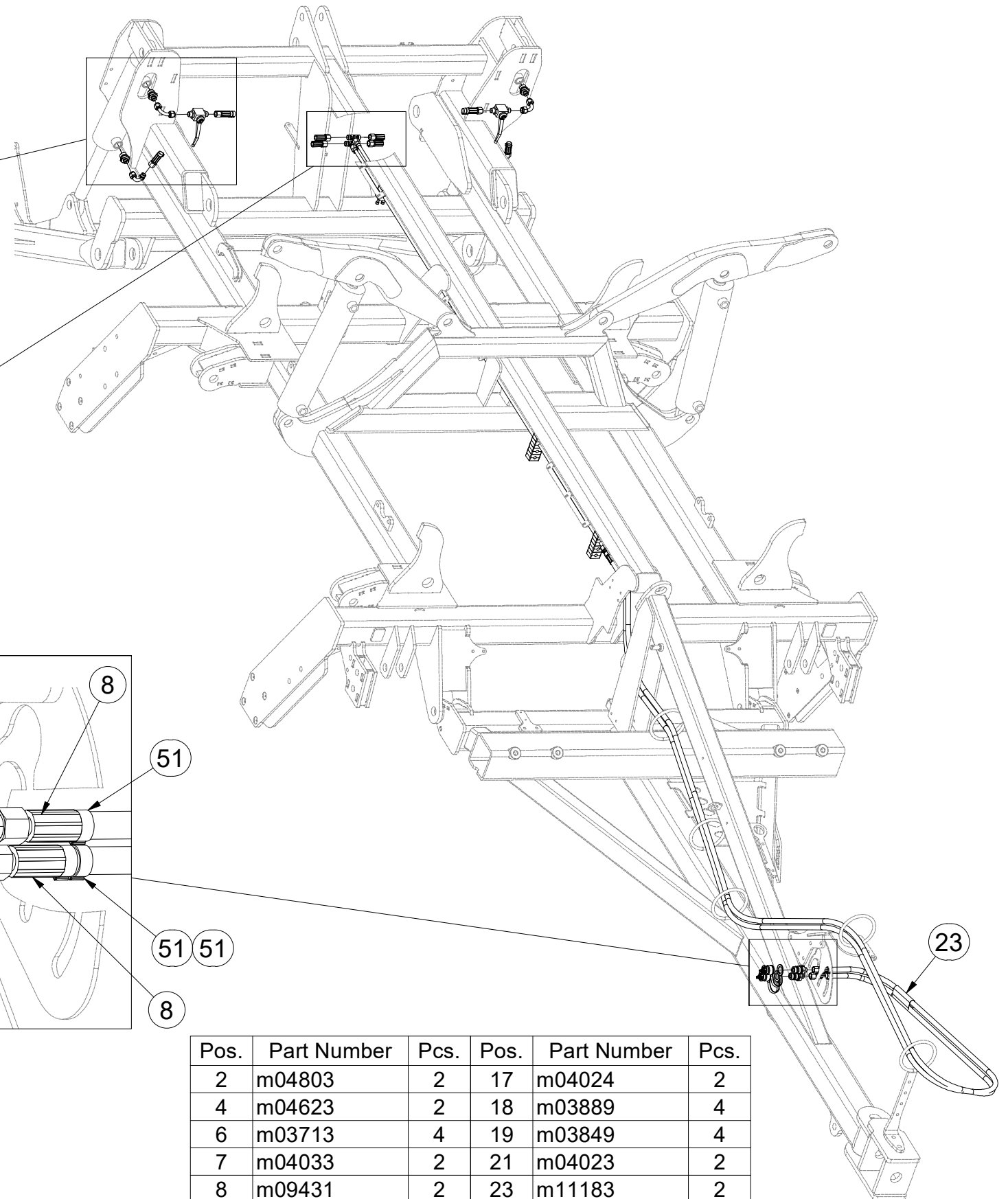
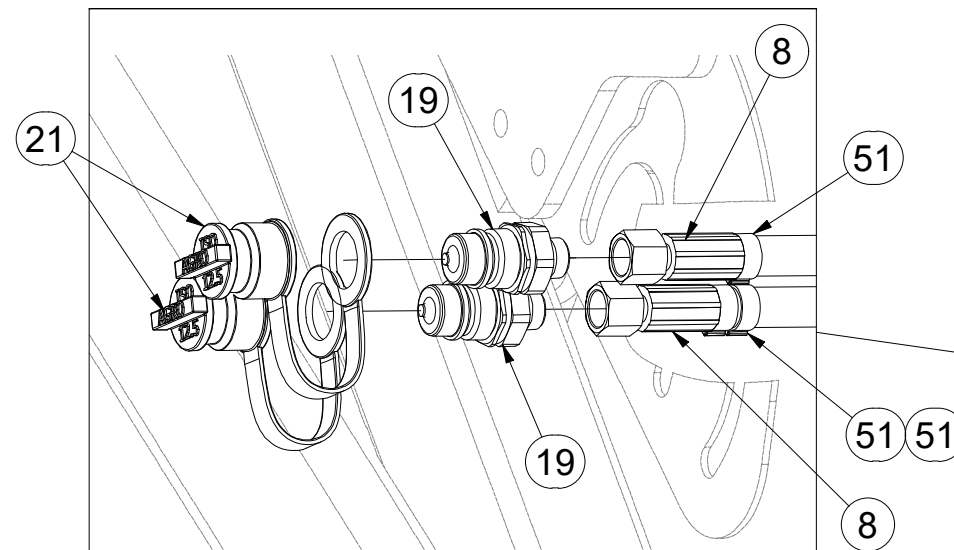
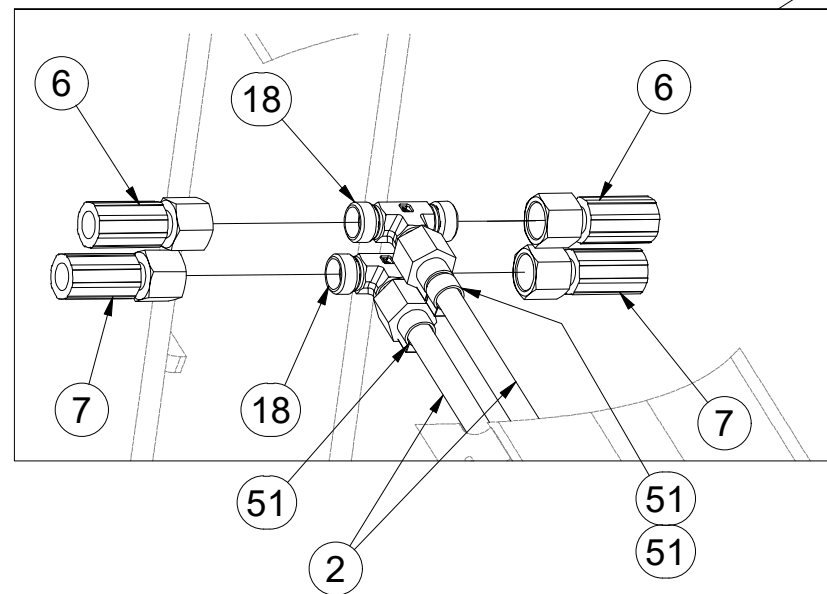
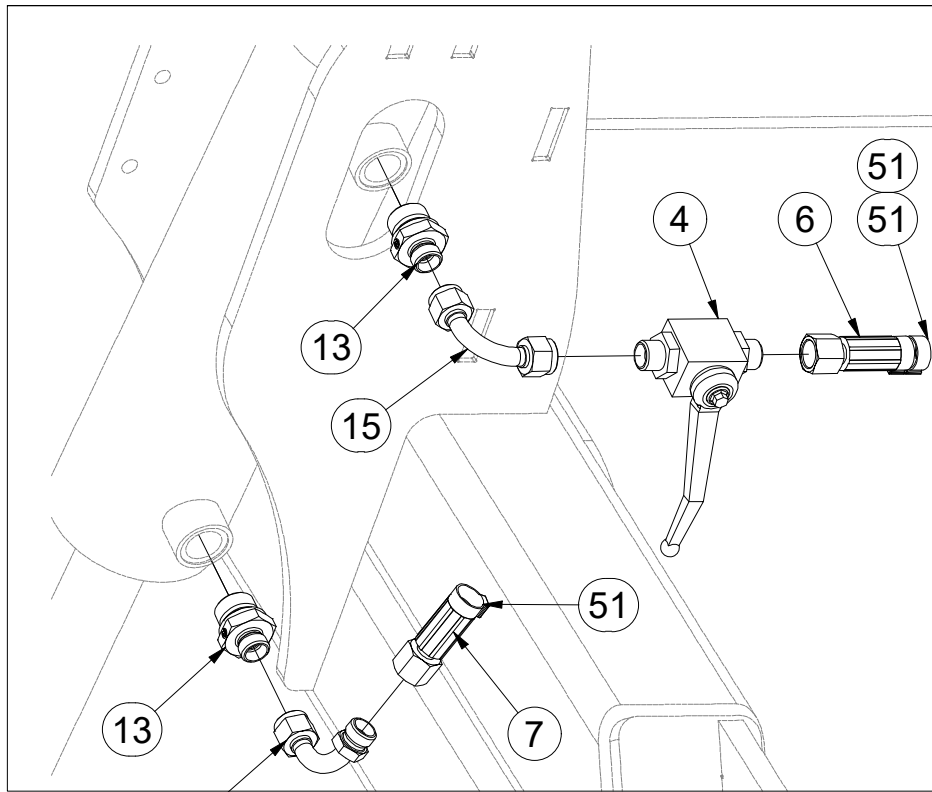

Pos.	Part Number	Pcs.	Pos.	Part Number	Pcs.
2	m04803	2	17	m04024	2
4	m04623	2	18	m03889	4
6	m03713	4	19	m03849	4
7	m04033	2	21	m04023	2
8	m09431	2	23	m11183	2
13	m09934	8	51	m11289	15
15	m04621	2			

ⒸZ HYDRAULIKA STROJE

Ⓓ HYDRAULIK DER MASCHINE

Ⓕ HYDRAULIQUE DE LA MACHINE

ⒼB MACHINE HYDRAULICS

Ⓔ RU ГИДРАВЛИКА МАШИНЫ

Ⓗ PL HYDRAULIKA MASZYN



3011328

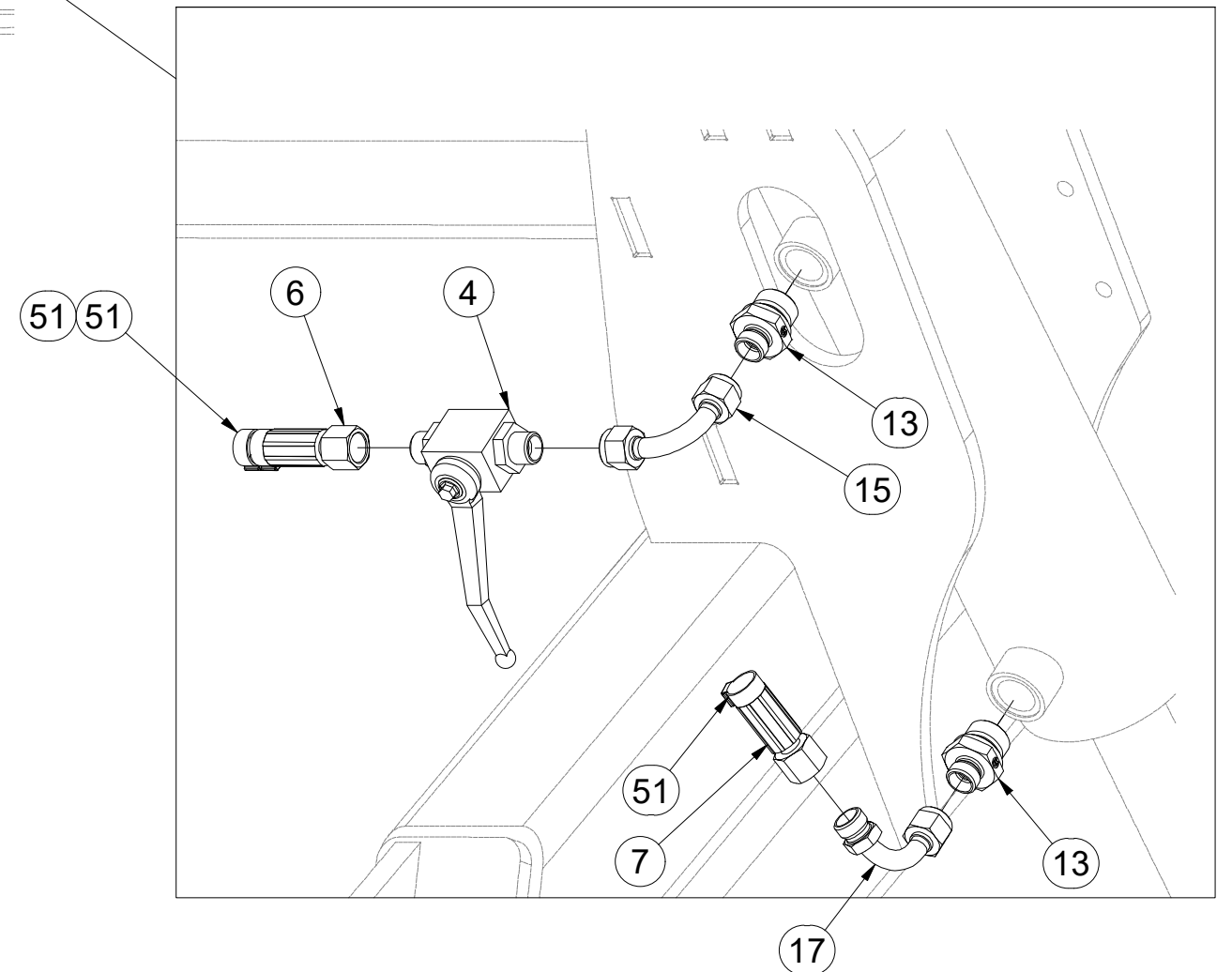
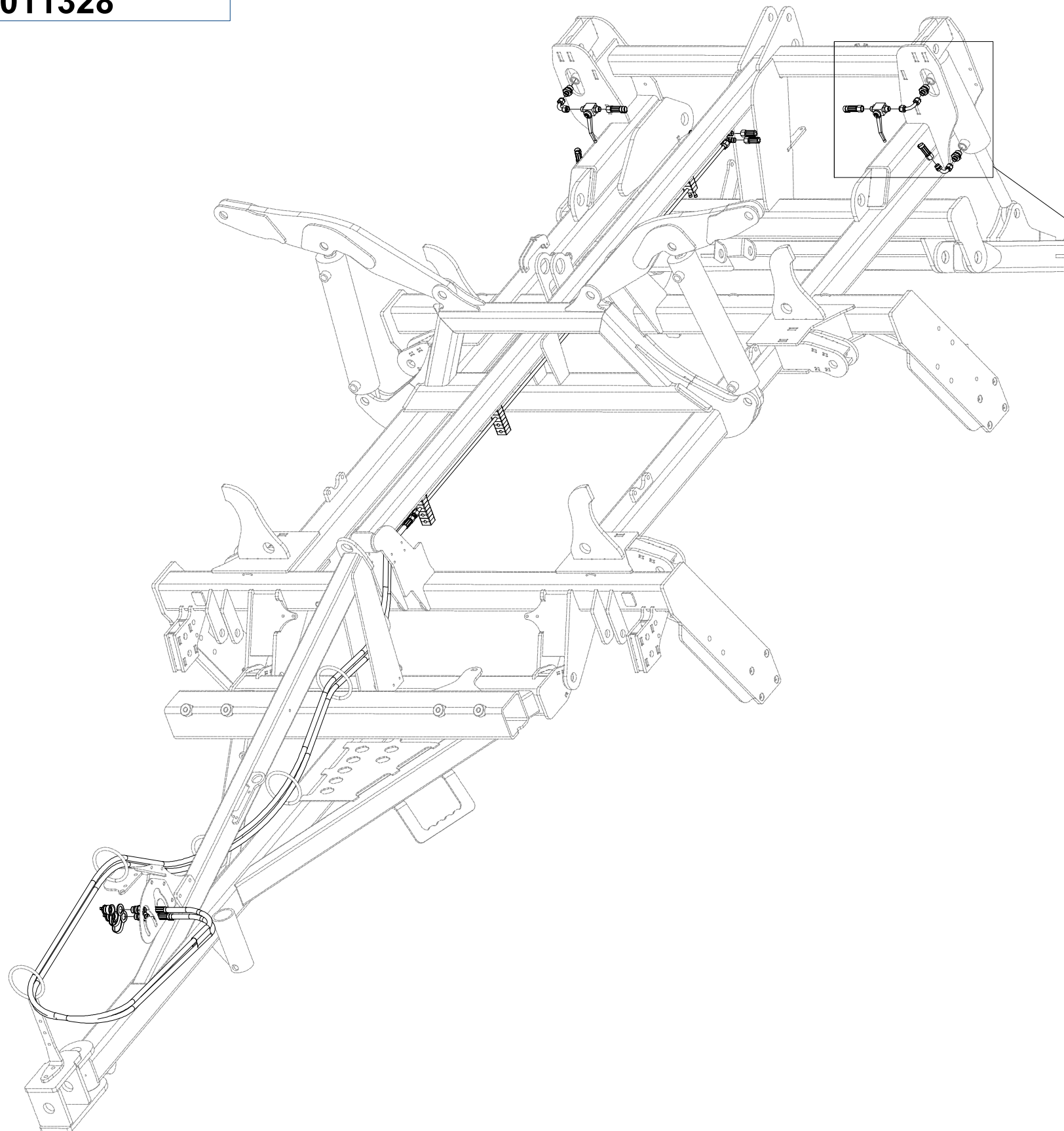

Pos.	Part Number	Pcs.
4	m04623	2
6	m03713	4
7	m04033	2
13	m09934	8
15	m04621	2
17	m04024	2
51	m11289	15

3011328

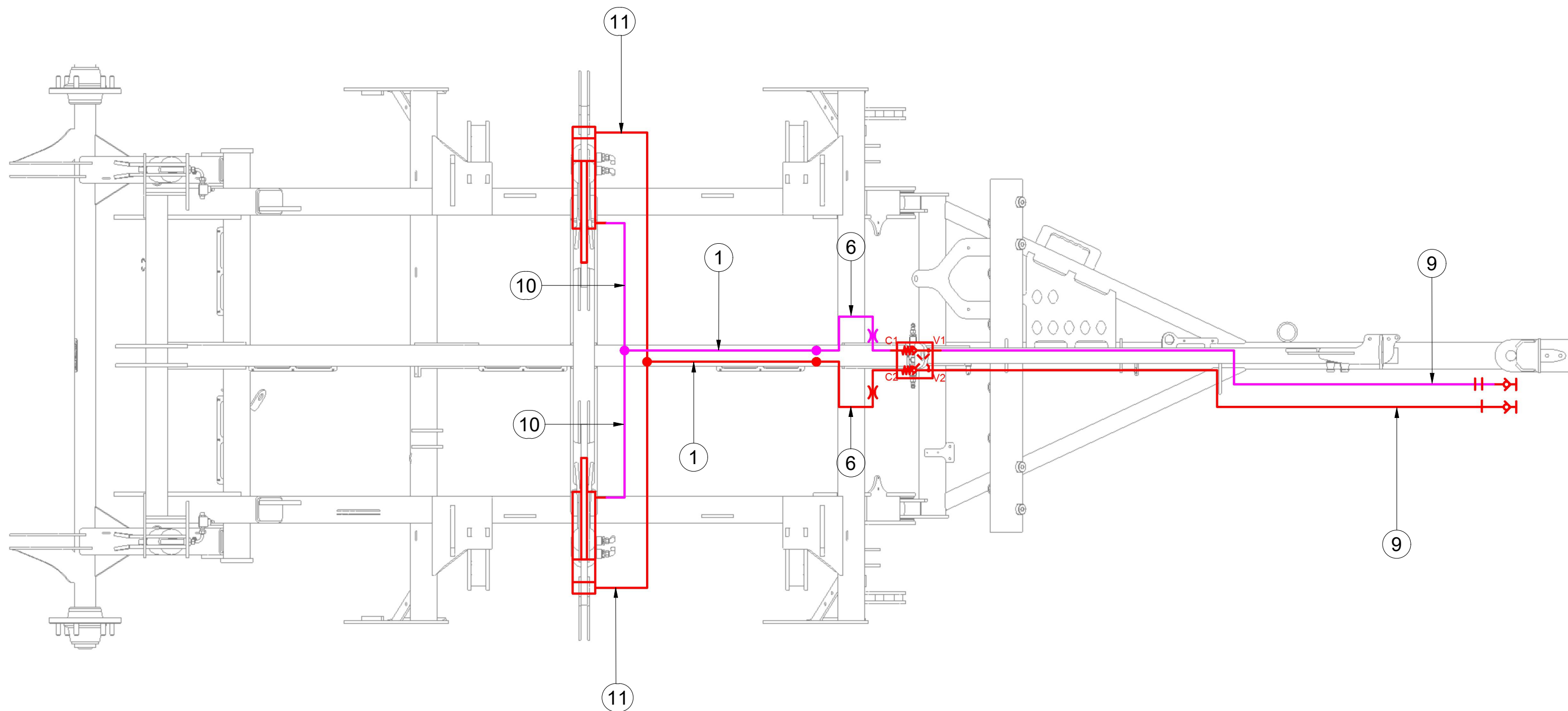

Pos.	Part Number	Pcs.
1	m03975	2
6	m03713	4
9	m04087	2
10	m07646	2
11	m07909	2

3011328

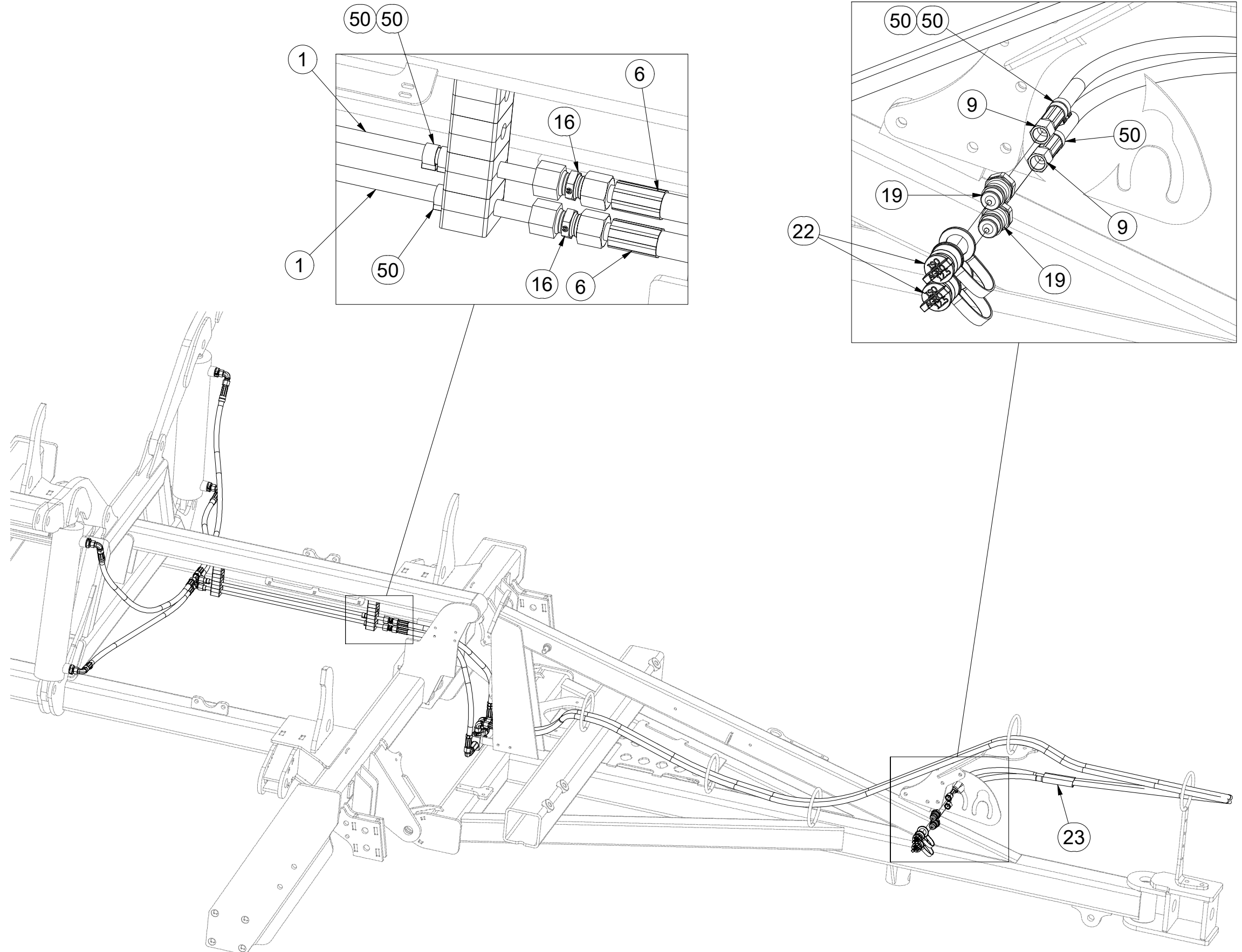

Pos.	Part Number	Pcs.
1	m03975	2
6	m03713	4
9	m04087	2
16	m03213	4
19	m03849	4
22	m04022	2
23	m11183	2
50	m11294	21

ⒸZ HYDRAULIKA STROJE

Ⓓ HYDRAULIK DER MASCHINE

Ⓕ HYDRAULIQUE DE LA MACHINE

ⒸB MACHINE HYDRAULICS

ⒸR ГИДРАВЛИКА МАШИНЫ

ⒸL HYDRAULIKA MASZYN



3011328

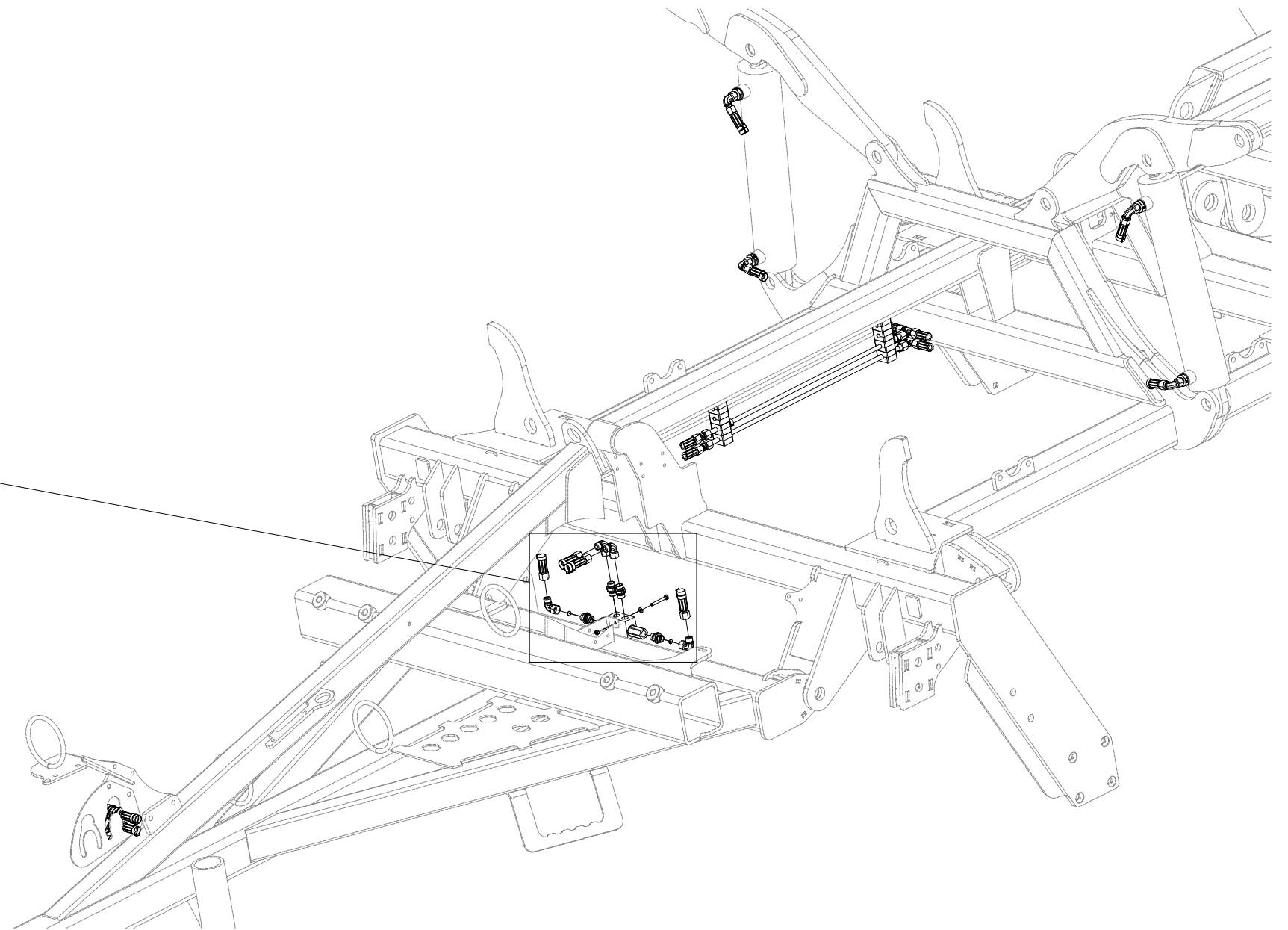
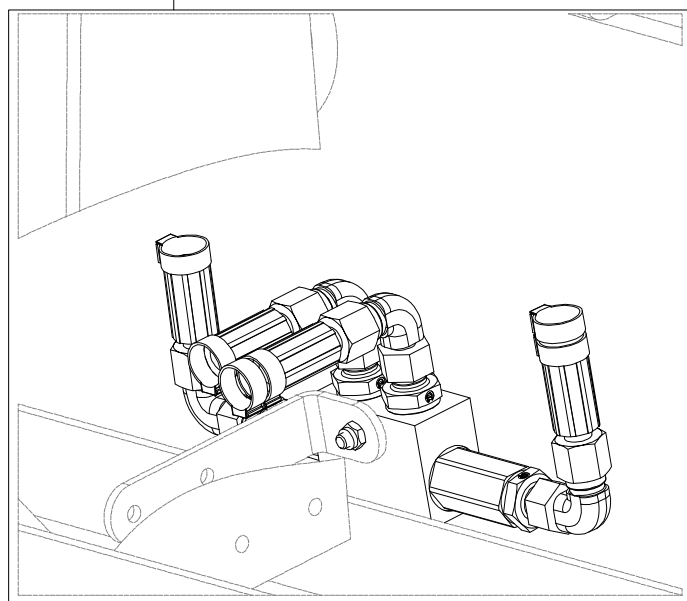
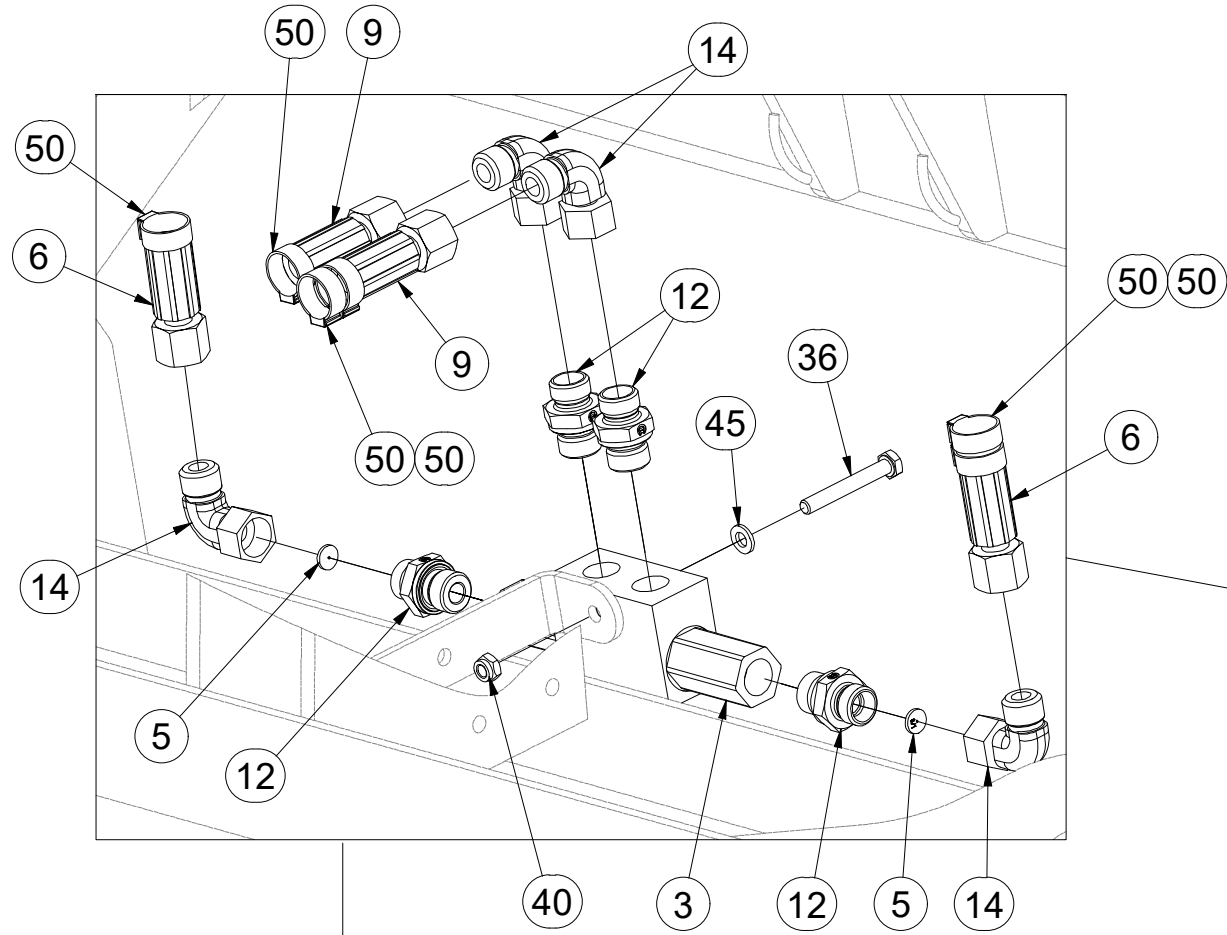

Pos.	Part Number	Pcs.
3	m06673	1
5	m10780	2
6	m03713	4
9	m04087	2
12	m06528	4
14	m06803	8
36	m05561	1
40	m05560	1
45	m01199	1
50	m11294	21

CZ HYDRAULIKA STROJE
 D HYDRAULIK DER MASCHINE
 F HYDRAULIQUE DE LA MACHINE

GB MACHINE HYDRAULICS
 RU ГИДРАВЛИКА МАШИНЫ
 PL HYDRAULIKA MASZYNY



3011328

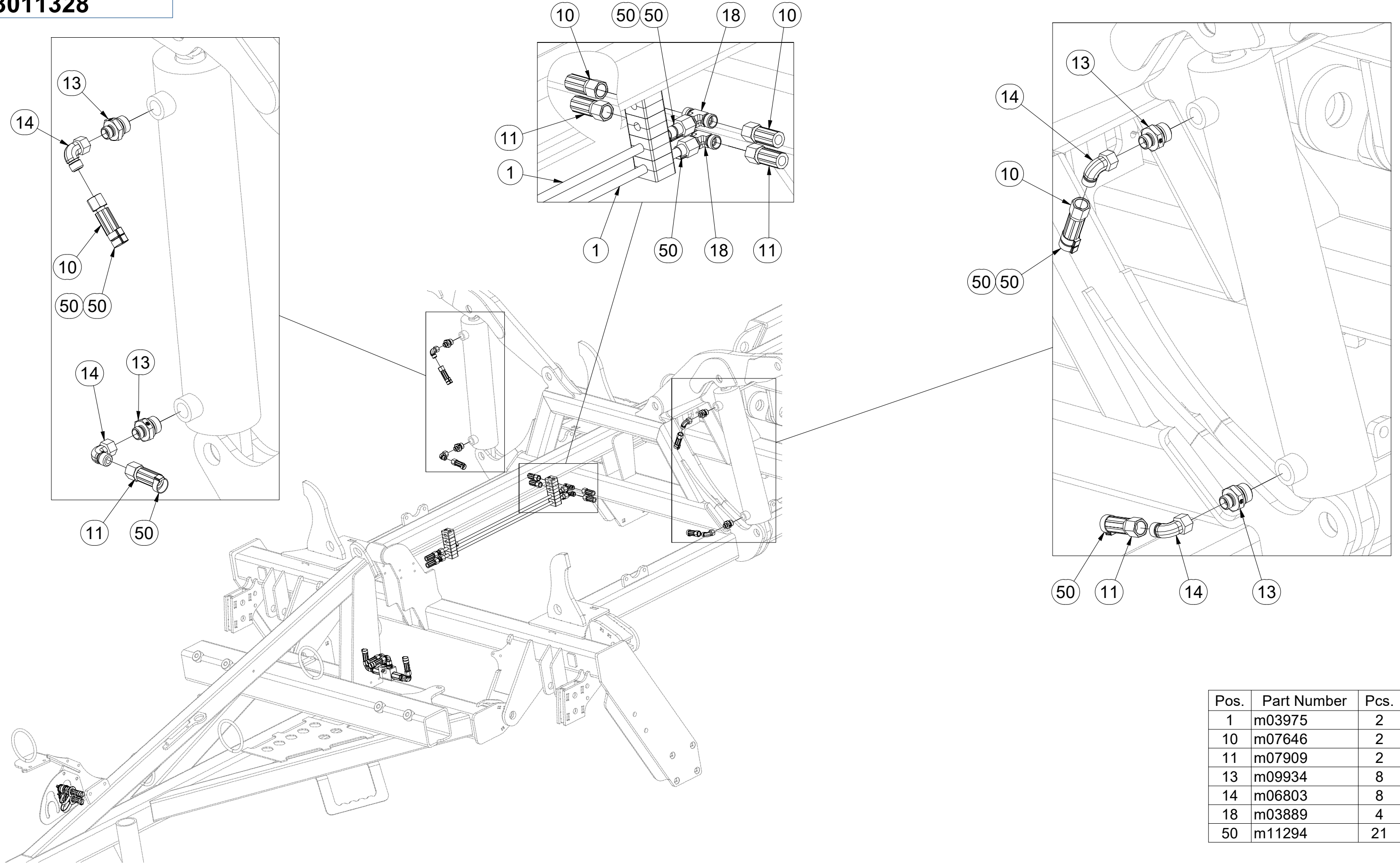

Pos.	Part Number	Pcs.
1	m03975	2
10	m07646	2
11	m07909	2
13	m09934	8
14	m06803	8
18	m03889	4
50	m11294	21

ⒸZ SADA KYPŘIČŮ STOP

Ⓓ SPURENLOCKERERSATZ

Ⓕ KIT DE CULTIVATEURS DE TRACES

3005537

ⒸB SET OF TRACK CULTIVATORS

Ⓔ КОМПЛЕКТ РЫХЛИТЕЛЕЙ КОЛЕИ

Ⓐ ZESTAW SPULCHNIACZY ŚLADÓW

Farmet

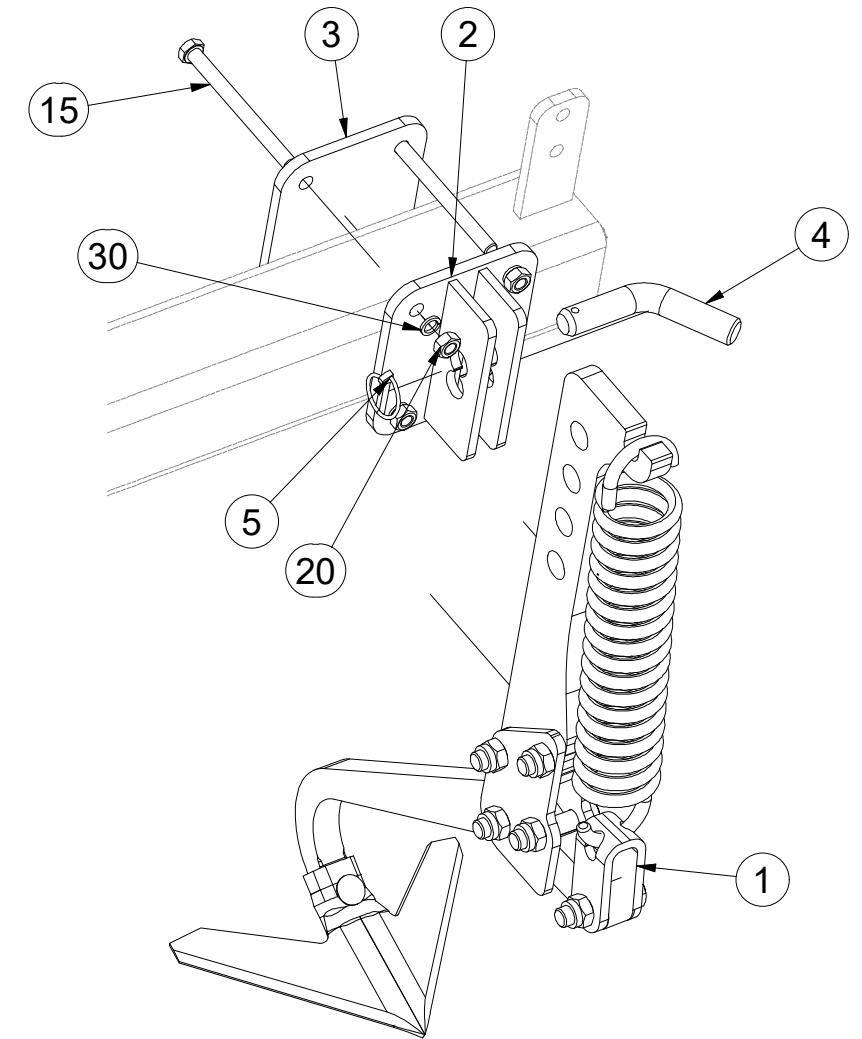
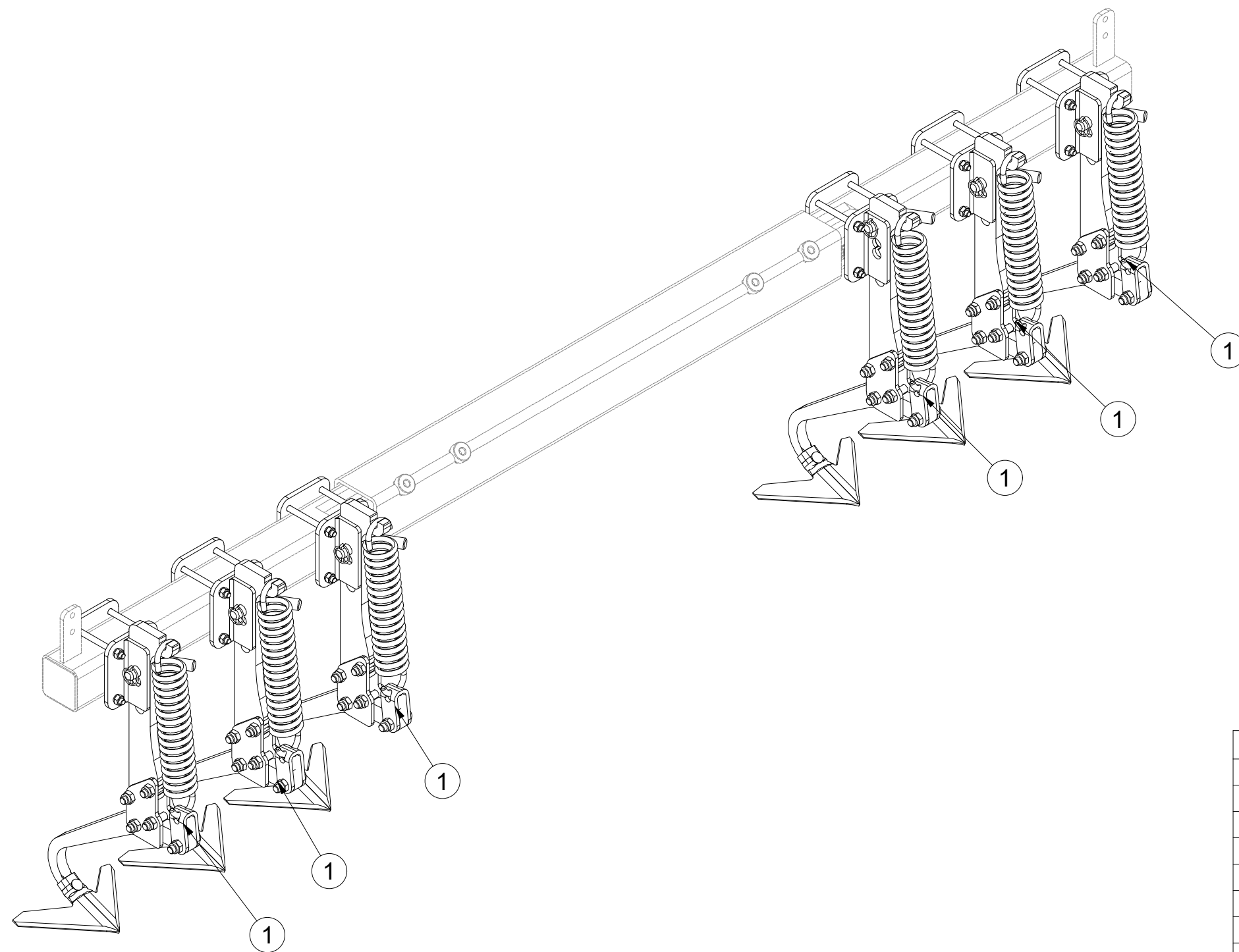

Pos.	Part Number	Pcs.
1	4026045	6
2	4019042	6
3	4009468	6
4	m08885	6
5	m10454	6
15	m05946	24
20	m01305	24
30	m03988	24

Ⓒ KYPŘIČ STOP

Ⓓ SPURENLOCKERER

Ⓕ CULTIVATEUR DES TRACES

Ⓖ TRACK CULTIVATOR

Ⓡ РЫХЛИТЕЛЬ КОЛЕИ

Ⓟ SPULCHNIARKA STÓP

Farmet

4026045

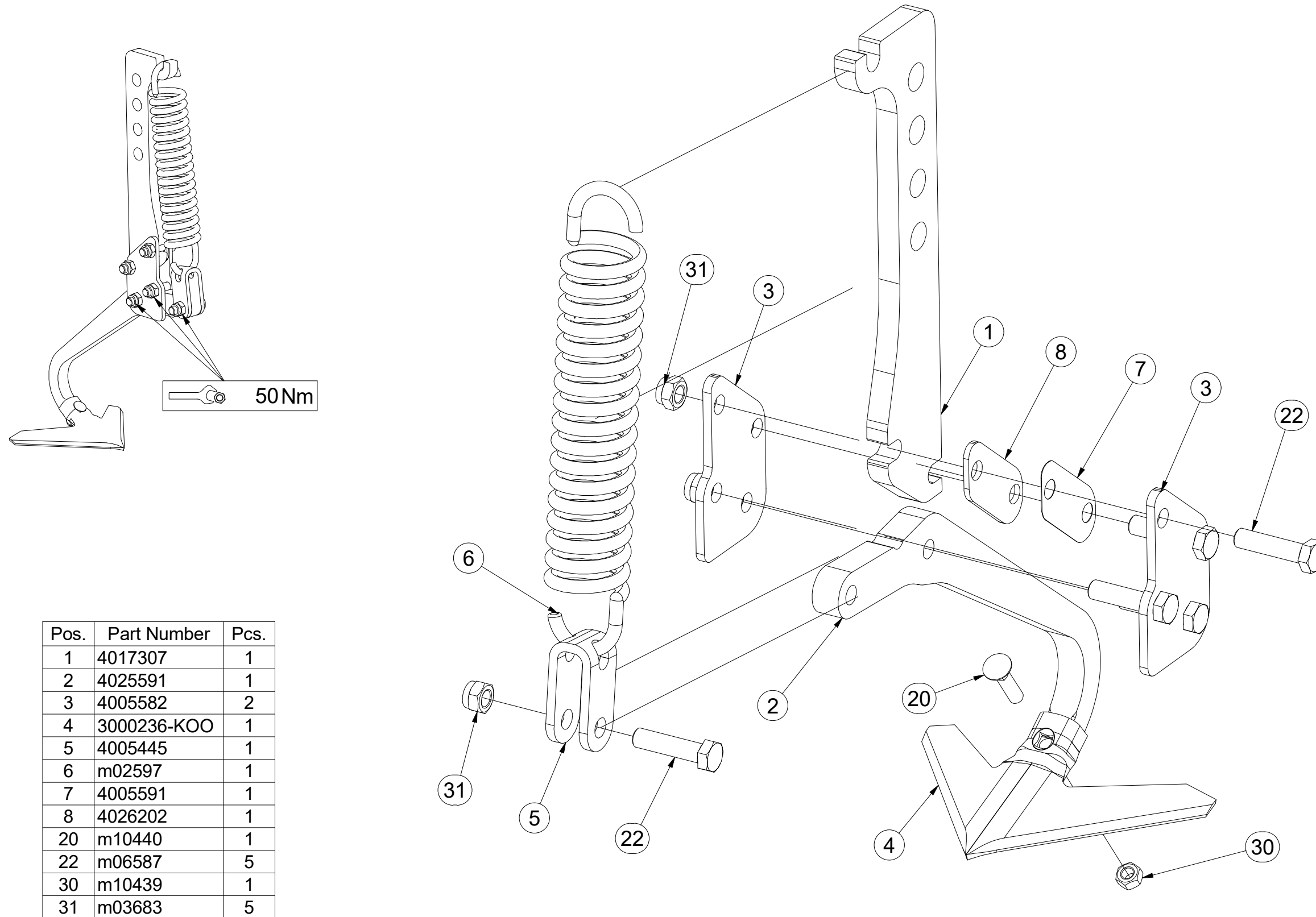

ⒸZ SADA PŘEDNÍCH SMYKŮ

Ⓓ SATZ VORDERE ACKERSCHLEPPEN

Ⓕ KIT DE NIVELEURS AVANT

3006127

ⒸGB SET OF FRONT LEVELLING BARS

ⒸRU КОМПЛЕКТ ПЕРЕДНИХ БОРОН

ⒸPL ZESTAW PRZEDNICH WŁÓK

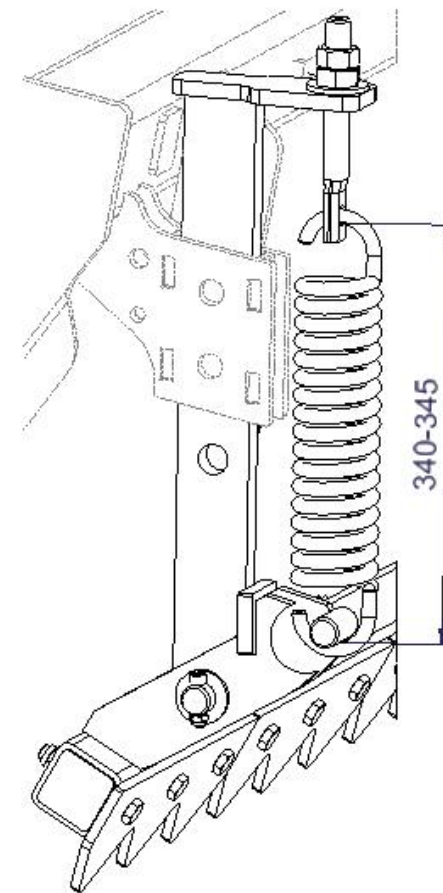
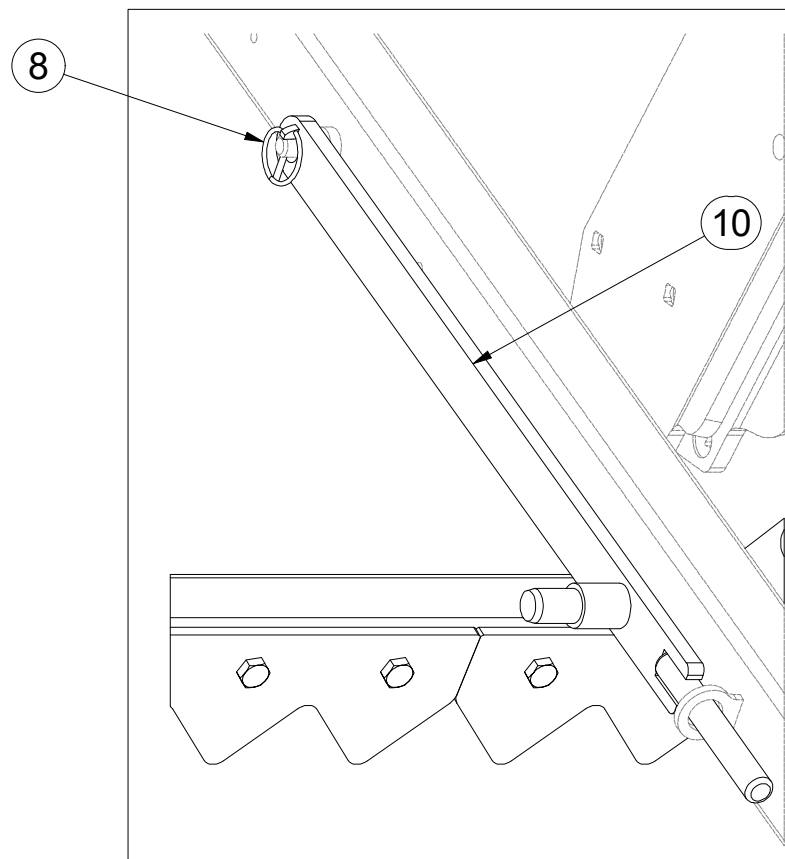
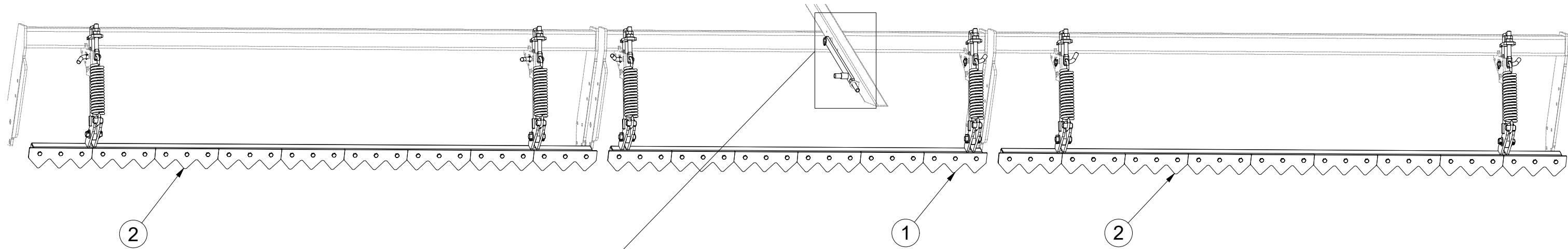

Pos.	Part Number	Pcs.
1	3010749	1
2	3011398	2
8	m10454	7
10	4006829	1

Ⓒ SADA PŘEDNÍCH SMYKŮ

Ⓓ SATZ VORDERE ACKERSCHLEPPEN

Ⓕ KIT DE NIVELEURS AVANT

Ⓖ SET OF FRONT LEVELLING BARS

Ⓡ КОМПЛЕКТ ПЕРЕДНИХ БОРОН

Ⓟ ZESTAW PRZEDNICH WŁÓK



3006127

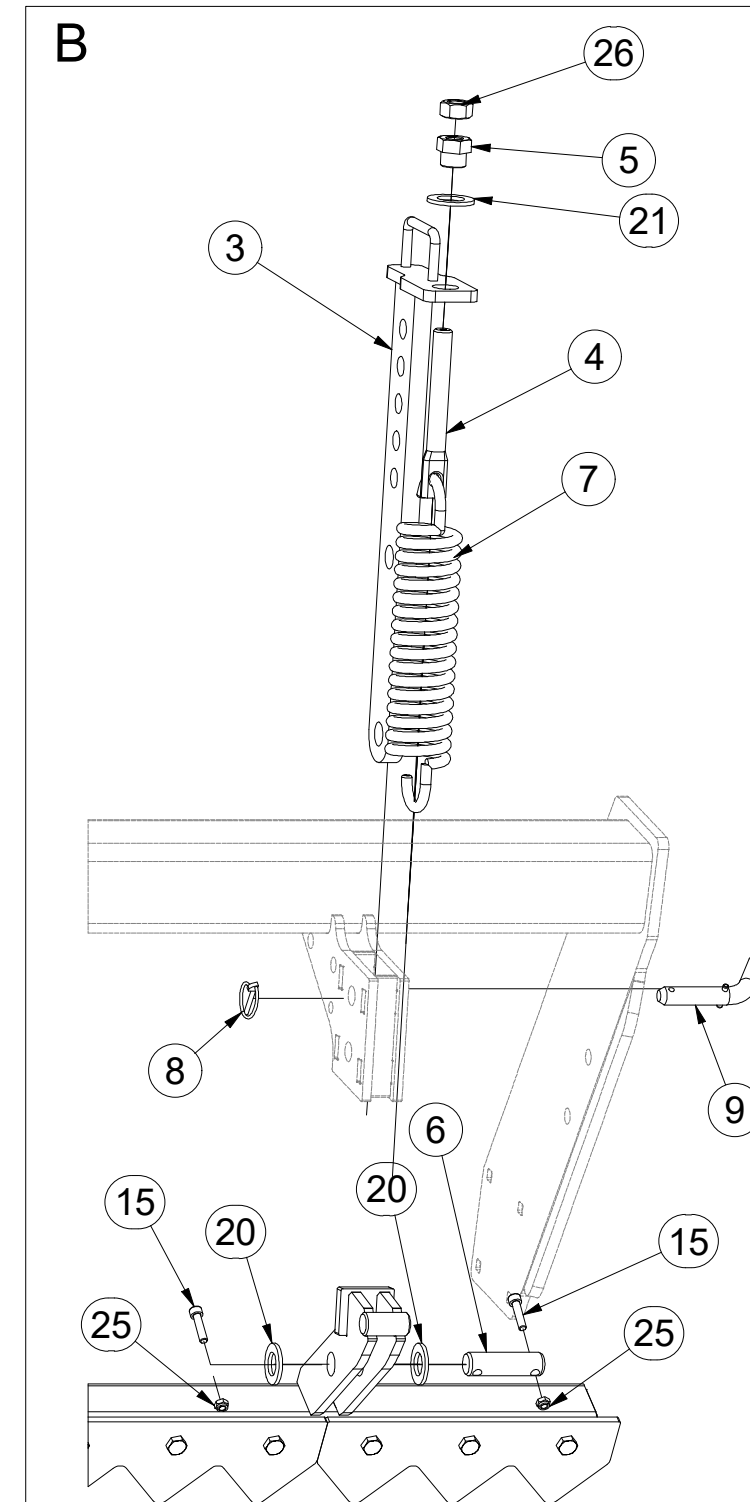
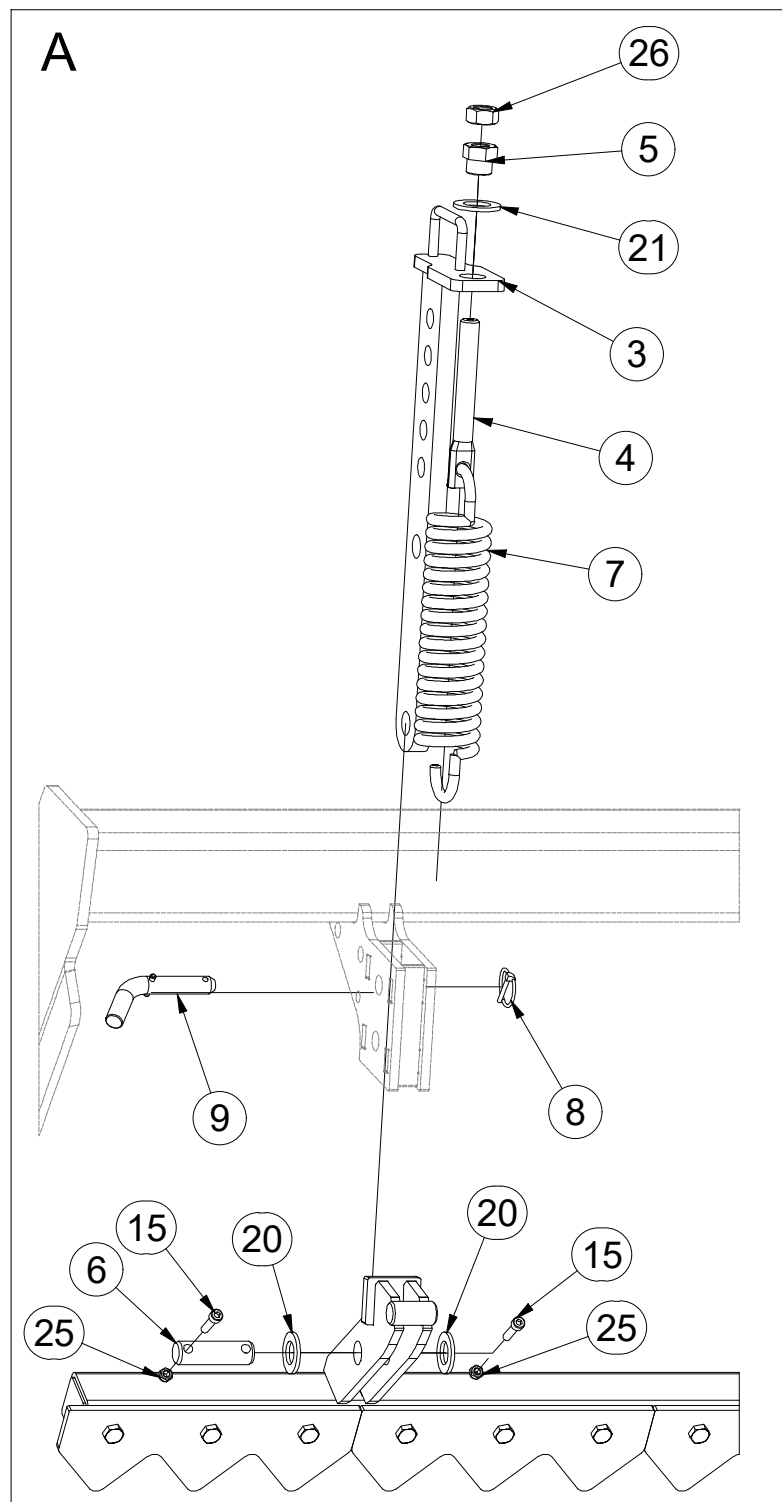
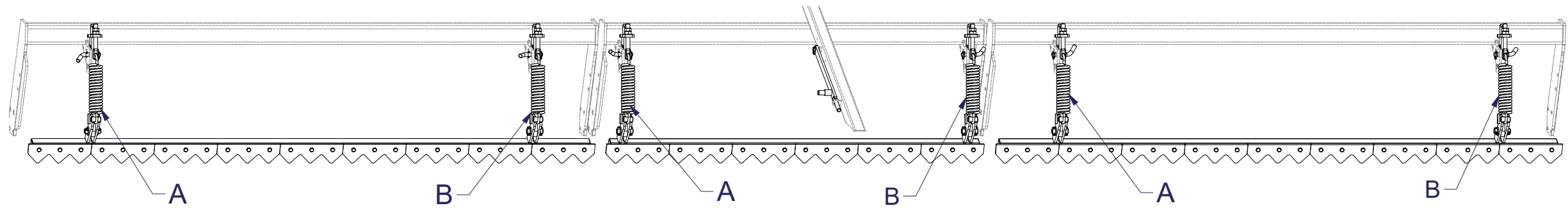

Pos.	Part Number	Pcs.
3	3008686	6
4	4003401	6
5	4000189	6
6	4010390	6
7	m02597	6
8	m10454	7
9	4012011	6
15	m09464	12
20	m14028	12
21	m01225	6
25	m04503	12
26	m01307	6

Ⓒ PŘEDNÍ SMYK

Ⓓ VORDERE ACKERSCHLEIFE

Ⓕ NIVELEUR AVANT

Ⓖ FRONT DRAG

Ⓡ ПЕРЕДНЯЯ БОРОНА

Ⓟ PRZEDNIA WŁÓKA

Farmet

3010749

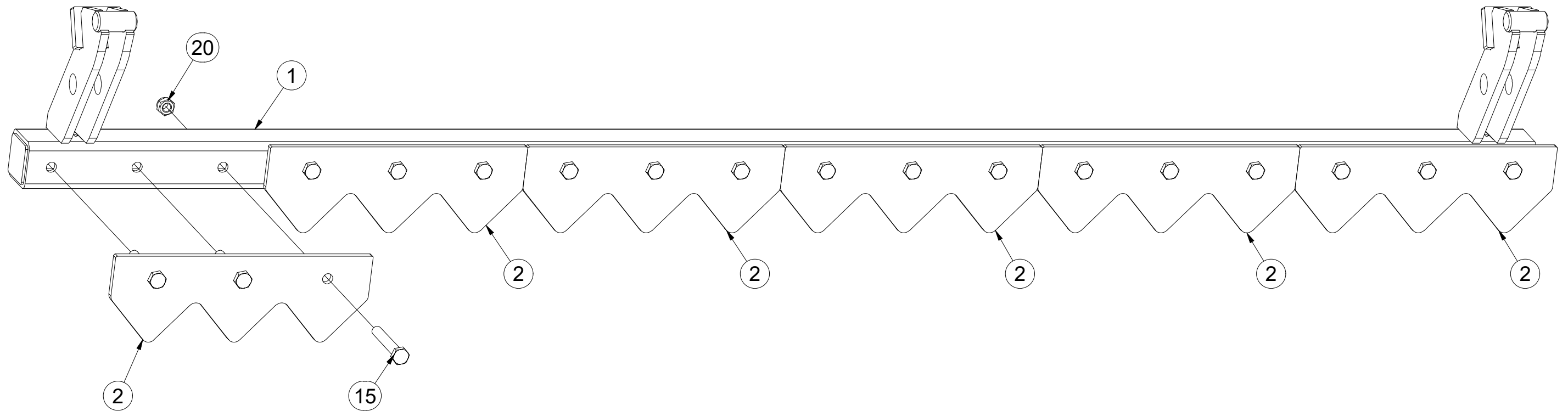

Pos.	Part Number	Pcs.
1	3010748	1
2	4021741	6
15	m09437	18
20	m04301	18

ⒸZ PŘEDNÍ SMYK

Ⓓ VORDERE ACKERSCHLEIFE

Ⓕ NIVELEUR AVANT

ⒸB FRONT DRAG

ⒸU ПЕРЕДНЯЯ БОРОНА

ⒸL PRZEDNIA WŁÓKA

Farmet

3011398

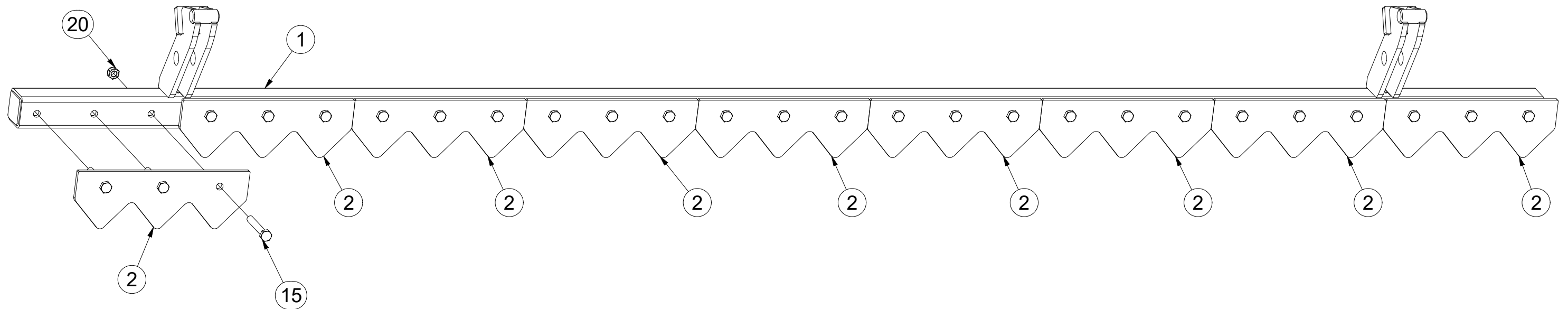

Pos.	Part Number	Pcs.
1	3011399	1
2	4021741	9
15	m09437	27
20	m04301	27

ⒸZ SADA PŘEDNÍCH VÁLCŮ

Ⓓ SATZ VORDERE WALZEN

Ⓕ KIT DE ROULEAUX AVANT

ⒼB SET OF FRONT ROLLERS

ⒶR КОМПЛЕКТ ПЕРЕДНИХ КАТКОВ

ⒶL ZESTAW PRZEDNICH WAŁÓW



3011904

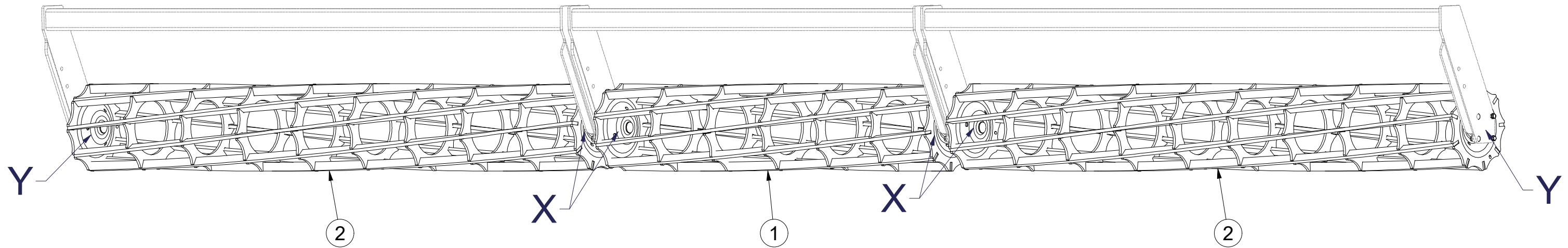

Y

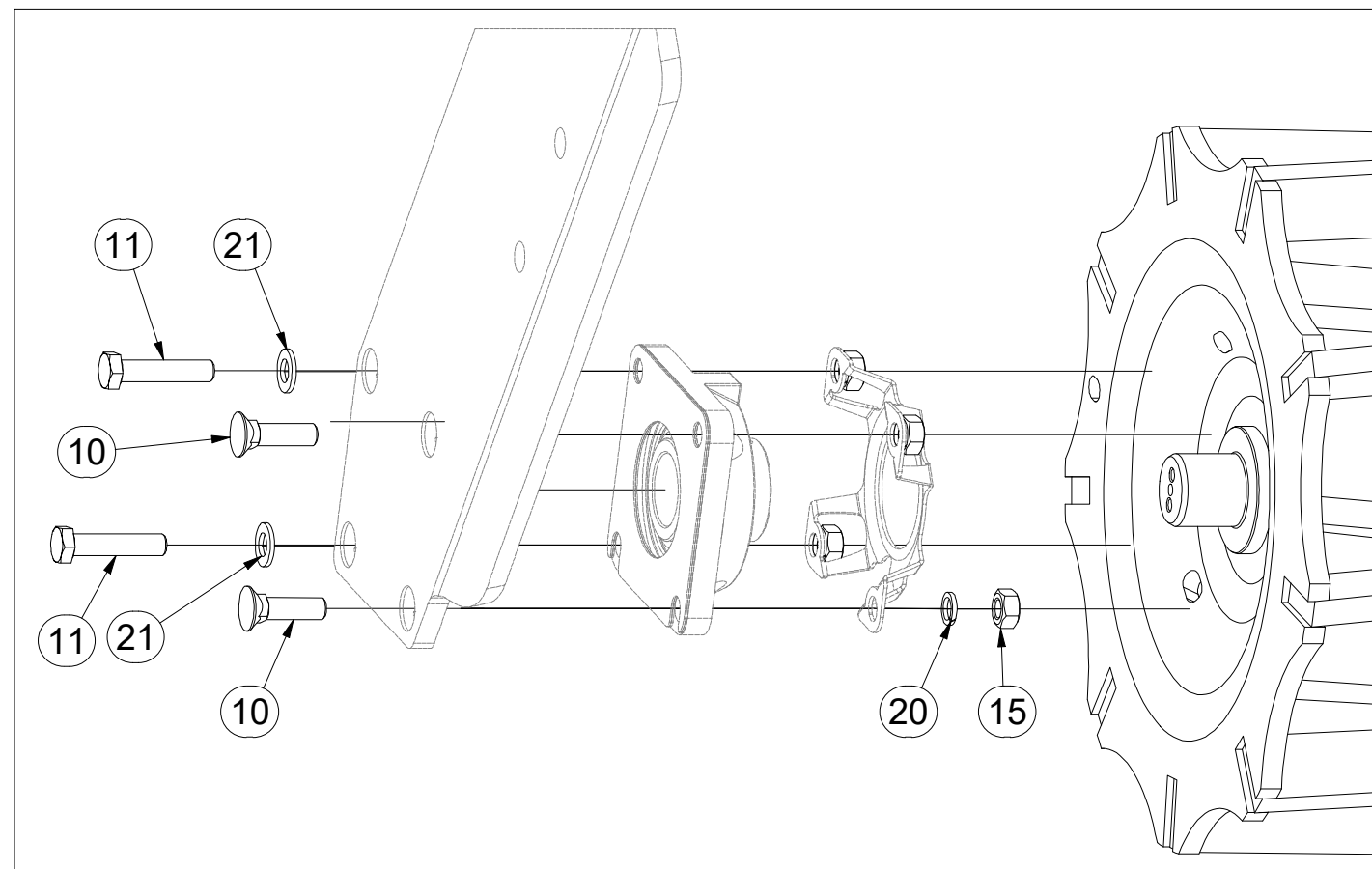

X

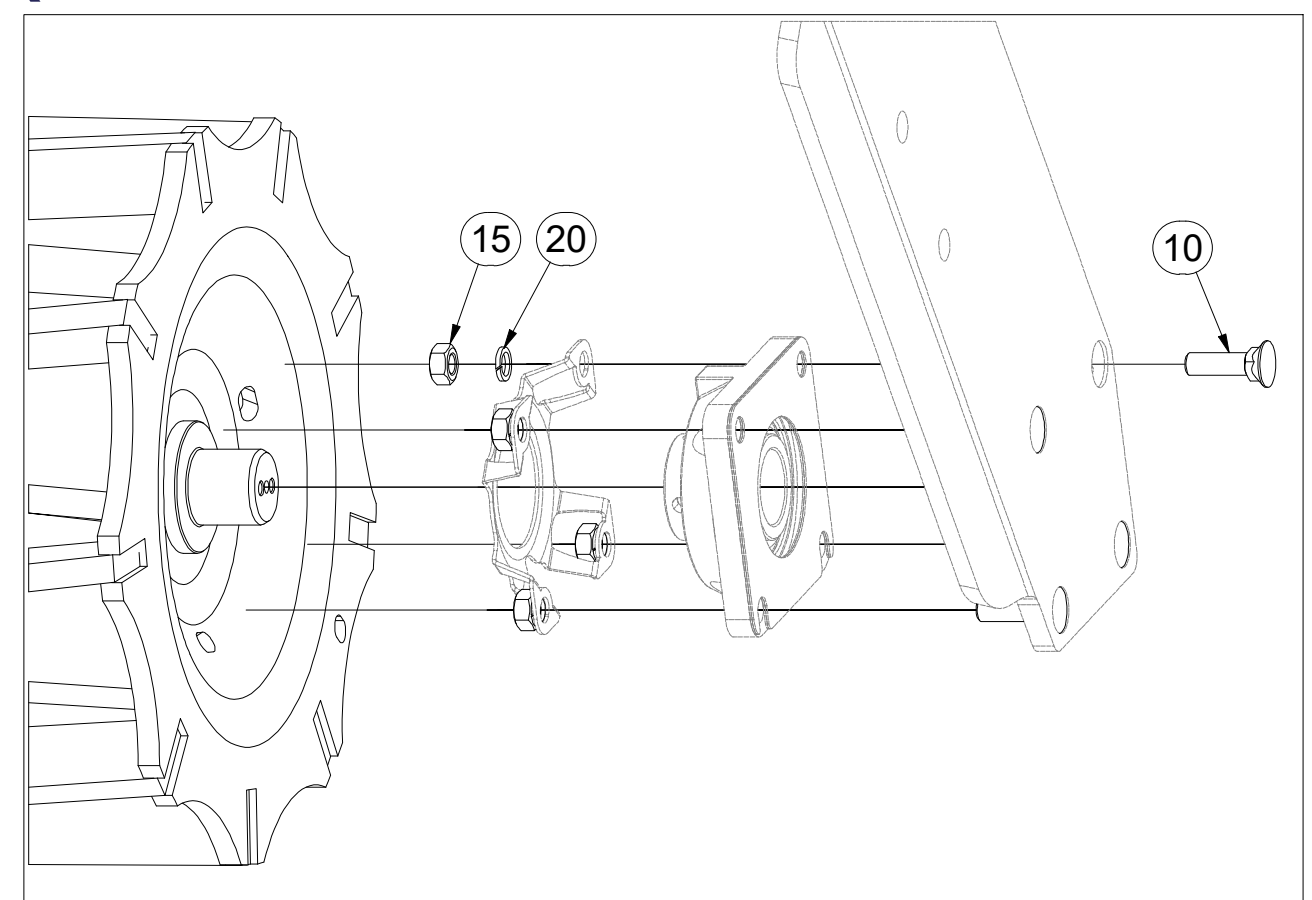

Pos.	Part Number	Pcs.	Pos.	Part Number	Pcs.
1	2000679	1	15	m01305	24
2	2001151	2	20	m03988	24
10	m03519	20	21	m17741	4
11	m04412	4			

- Ⓒ SADA LOŽISEK
- Ⓓ SATZ LAGER
- Ⓕ KIT DE ROULEMENTS

- Ⓖ SET OF BEARINGS
- Ⓡ КОМПЛЕКТ ПОДШИПНИКОВ
- Ⓟ ZESTAW ŁOŻYSK



VZ00012467

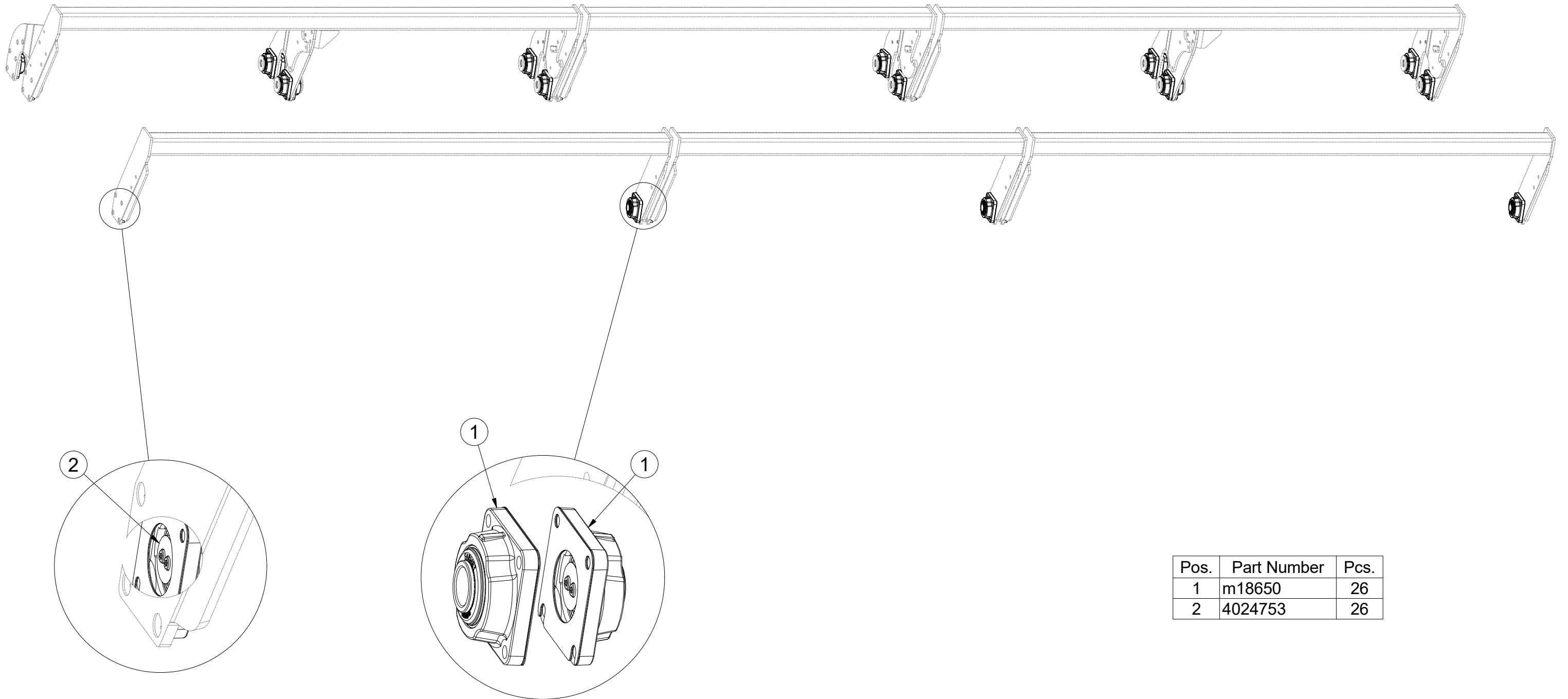

Pos.	Part Number	Pcs.
1	m18650	26
2	4024753	26

- Ⓒ CZ SADA LOŽISEK
- Ⓓ D SATZ LAGER
- Ⓕ F KIT DE ROULEMENTS

- Ⓖ GB SET OF BEARINGS
- Ⓡ RU КОМПЛЕКТ ПОДШИПНИКОВ
- Ⓟ PL ZESTAW ŁOŻYSK



VZ00012467

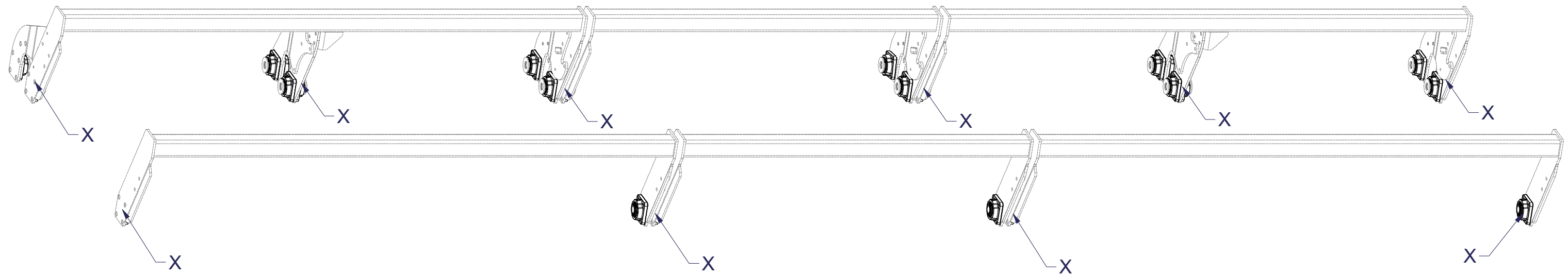

X

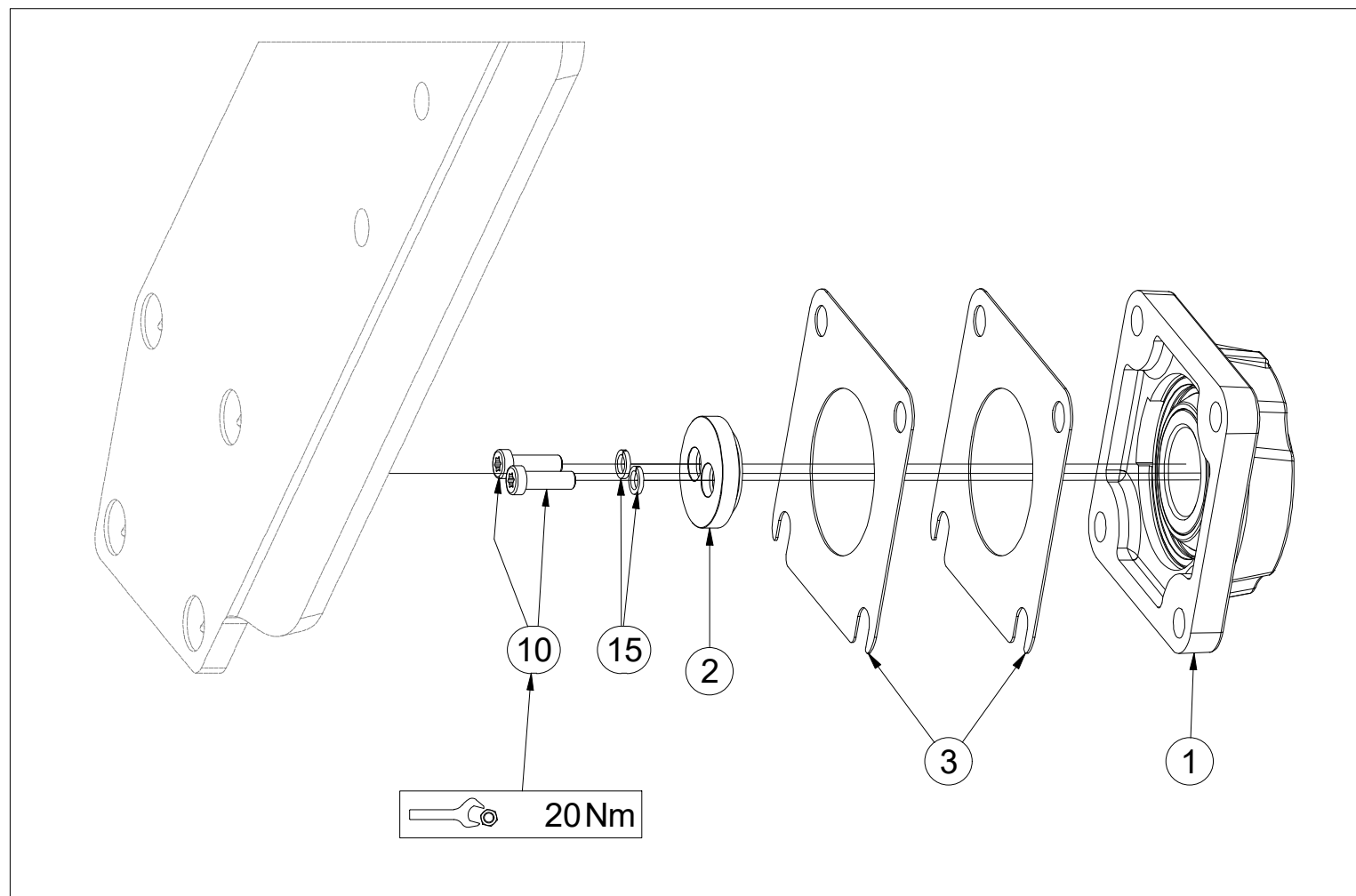

Pos.	Part Number	Pcs.
1	m18650	26
2	4024753	26
3	4016809	52
10	m18858	52
15	m01202	52

CZ SADA OVLÁDÁNÍ RADLICE
 D STEUERSATZ PFLUGSCHAREN
 F KIT DE COMMANDE DES SOCS

GB SET OF PLOUGHSHARE CONTROL
 RU КОМПЛЕКТ УПРАВЛЕНИЯ ЛАП
 PL ZESTAW STEROWANIA RADLICAMI



VZ00003341

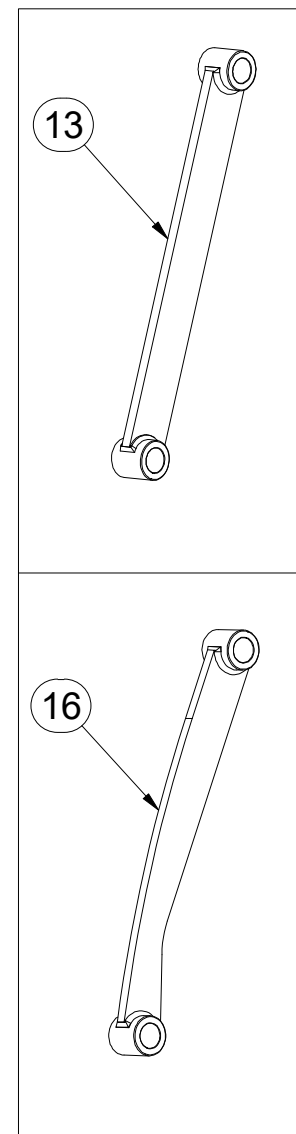
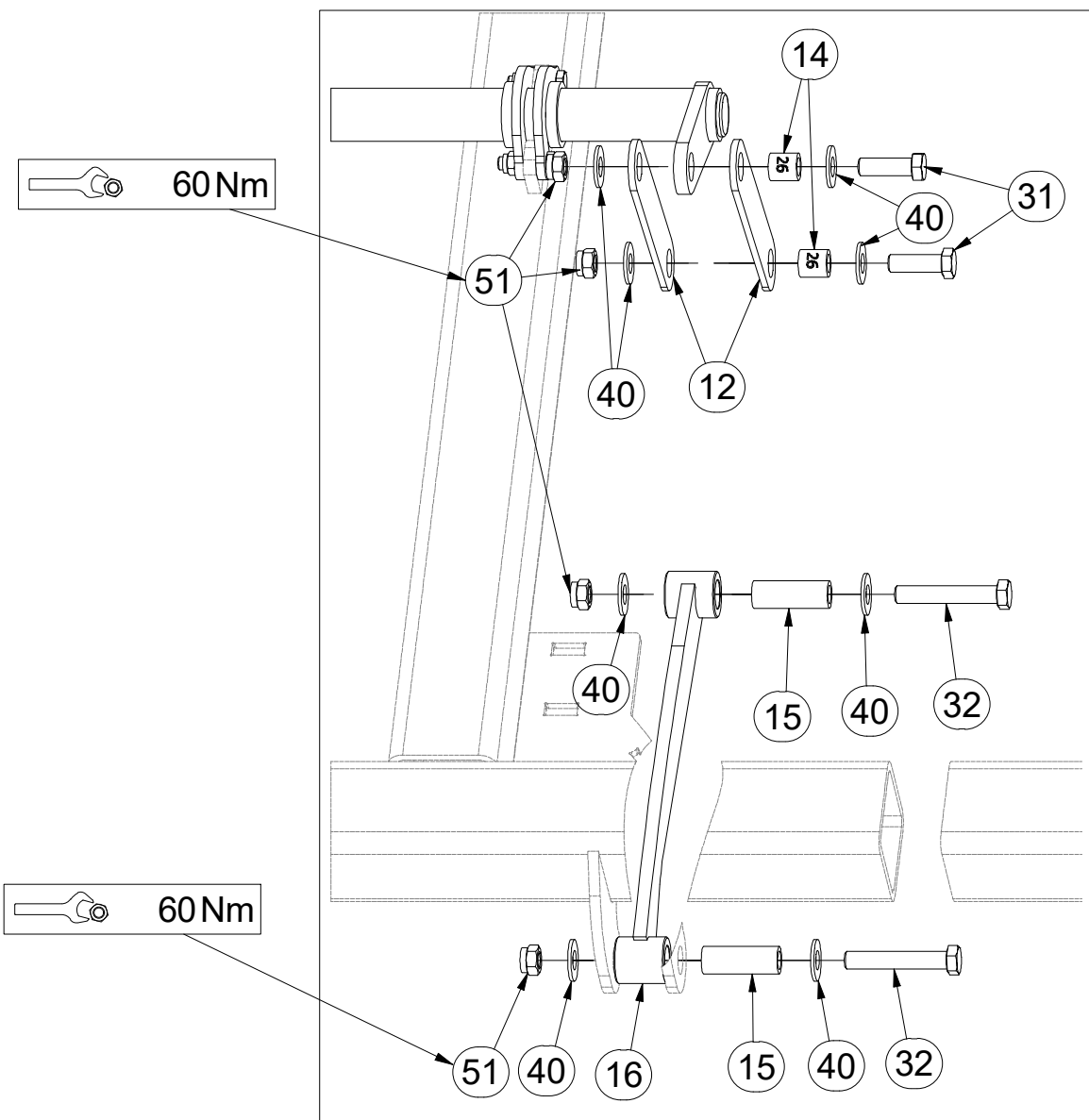
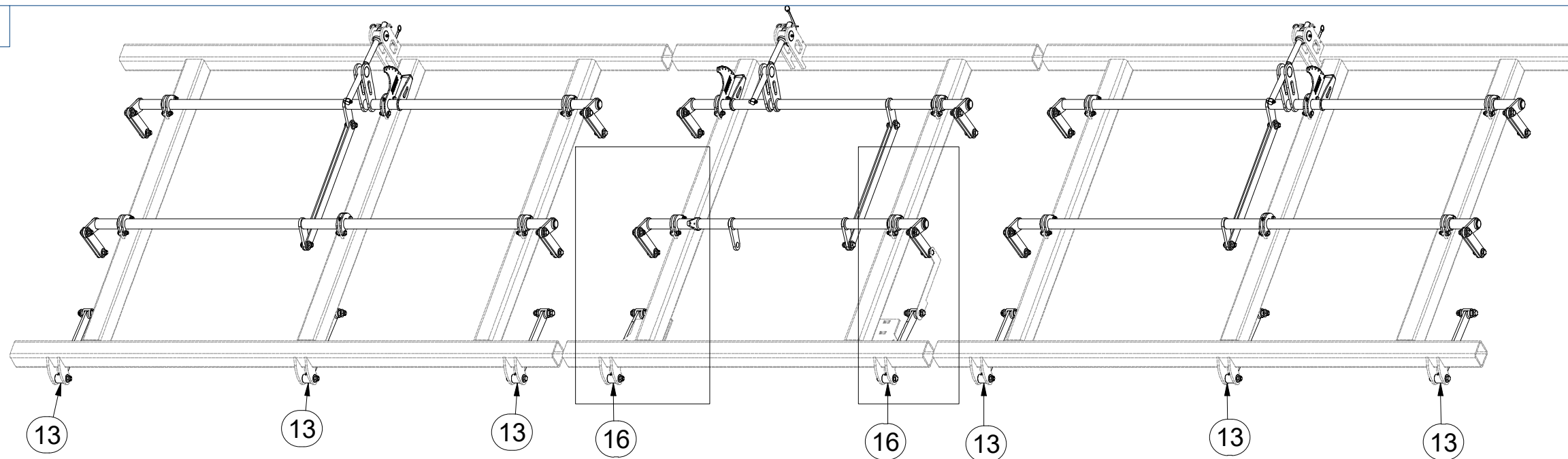

Pos.	Part Number	Pcs.
1	3002831	1
12	4005333	24
13	4003971	6
14	4002265	30
15	9001426	16
16	VZ00003342	2
31	m04355	30
32	m07673	16
40	m05651	92
51	m03683	46

CZ SADA OVLÁDÁNÍ RADLICE
 D STEUERSATZ PFLUGSCHAREN
 F KIT DE COMMANDE DES SOCS

GB SET OF PLOUGHSHARE CONTROL
 RU КОМПЛЕКТ УПРАВЛЕНИЯ ЛАП
 PL ZESTAW STEROWANIA RADLICAMI



VZ00003341

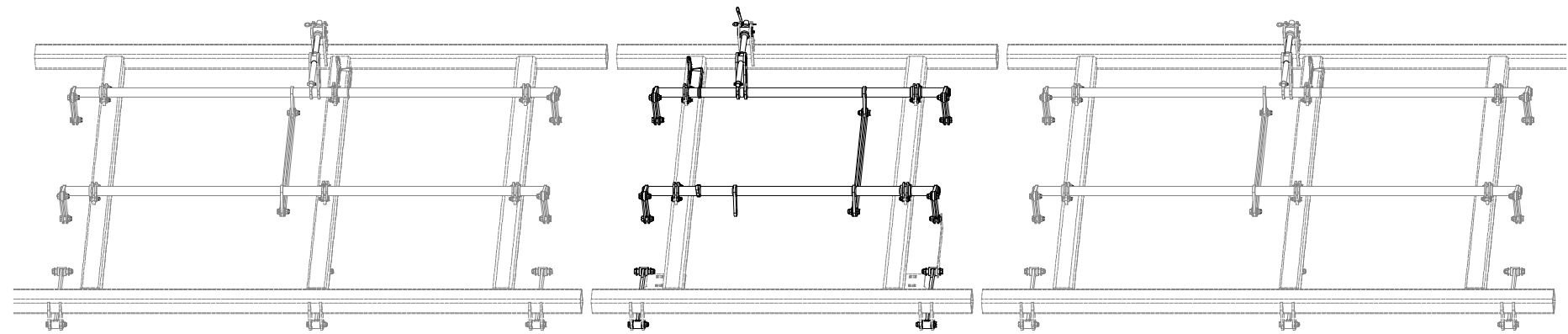
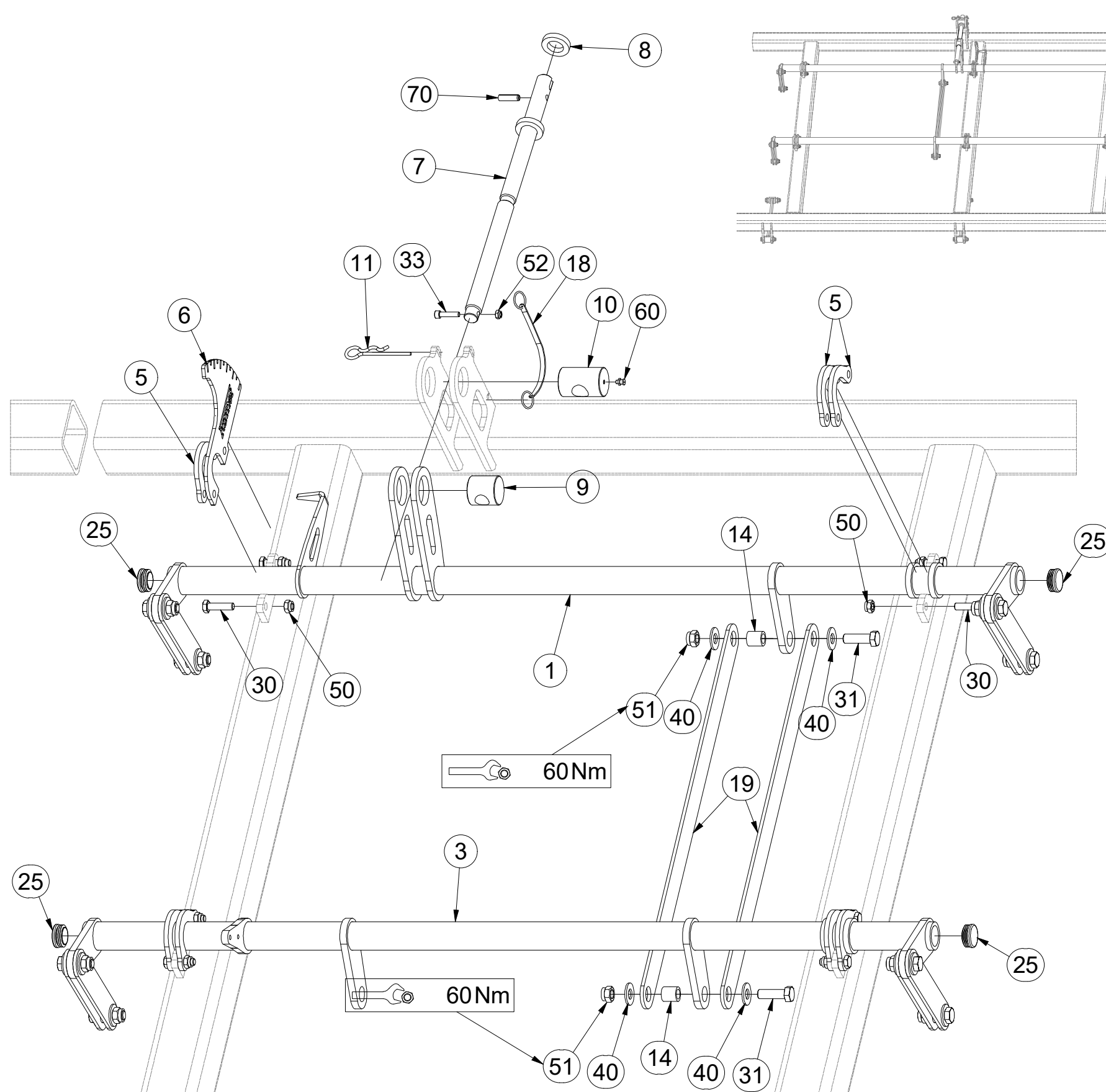

Pos.	Part Number	Pcs.
1	3002831	1
3	VZ00007199	1
5	4005332	23
6	4023896	3
7	4024250	3
8	9002560	3
9	4005340	3
10	9002114	3
11	m09988	3
14	4002265	30
18	m12467	3
19	4005334	6
25	m10130	12
30	m06077	32
31	m04355	30
33	m09464	3
40	m05651	92
50	m04301	32
51	m03683	46
52	m04503	3
60	m10451	3
70	m10736	3

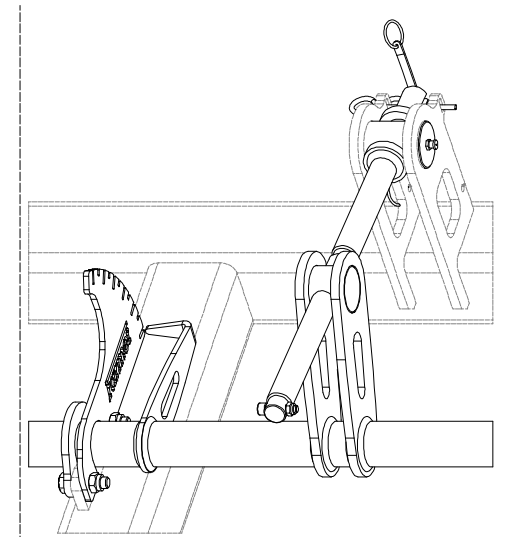

Ⓒ SADA OVLÁDÁNÍ RADLICE

Ⓓ STEUERSATZ PFLUGSCHAREN

Ⓕ KIT DE COMMANDE DES SOCS

Ⓖ SET OF PLOUGHSHARE CONTROL

Ⓡ КОМПЛЕКТ УПРАВЛЕНИЯ ЛАП

Ⓢ ZESTAW STEROWANIA RADLICAMI



VZ00003341

Pos.	Part Number	Pcs.	Pos.	Part Number	Pcs.
2	3002863	2	19	4005334	6
4	3002864	2	25	m10130	12
5	4005332	23	30	m06077	32
6	4023896	3	31	m04355	30
7	4024250	3	33	m09464	3
8	9002560	3	40	m05651	92
9	4005340	3	50	m04301	32
10	9002114	3	51	m03683	46
11	m09988	3	52	m04503	3
14	4002265	30	60	m10451	3
17	4022084	6	70	m10736	3
18	m12467	3			

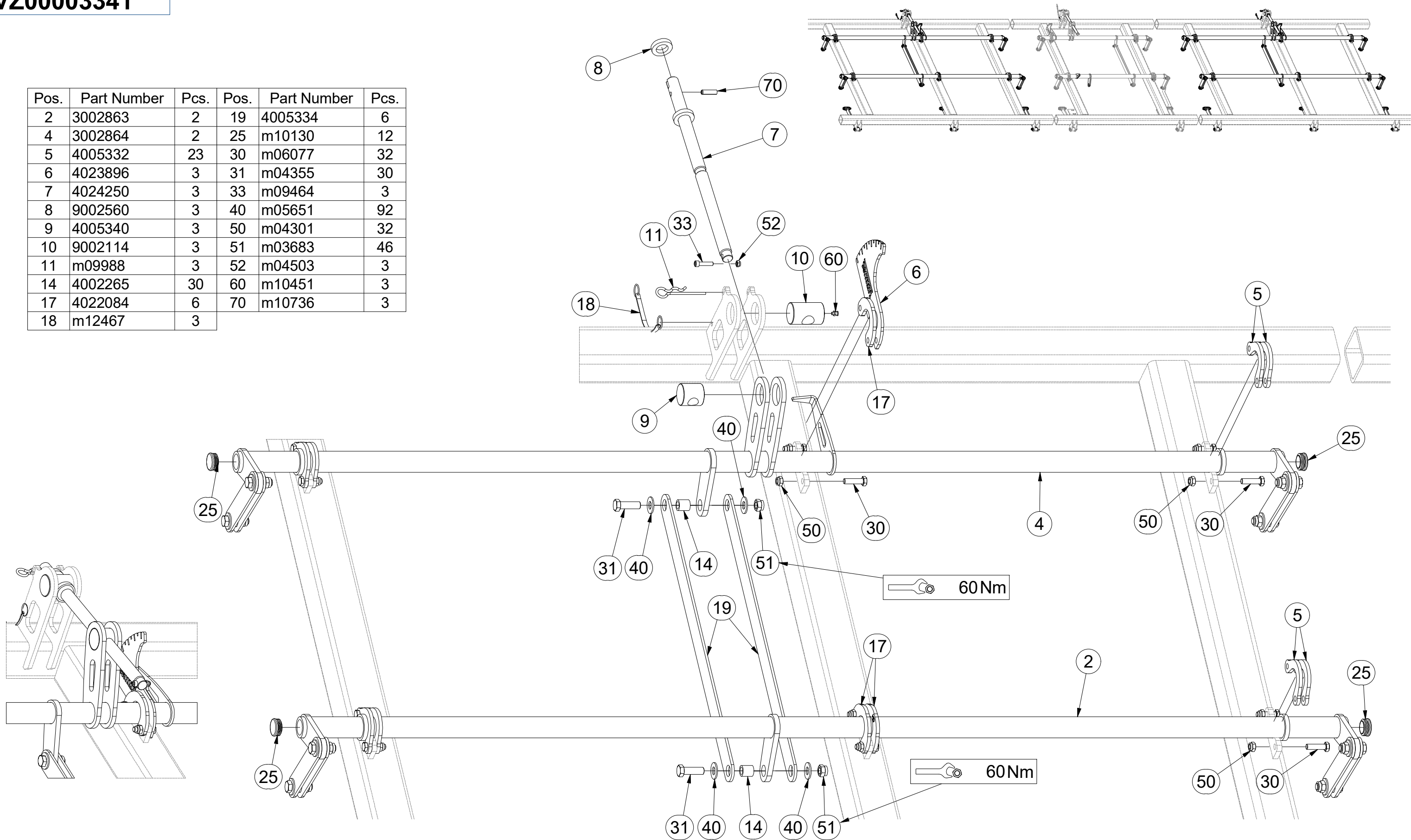

Ⓒ SADA RADLIC

Ⓓ SCHARSATZ

Ⓕ KIT DE SOCS

Ⓖ SET OF PLOUGHSHARES

Ⓡ КОМПЛЕКТ ЛАП

Ⓟ ZESTAW REDLIC



3002847

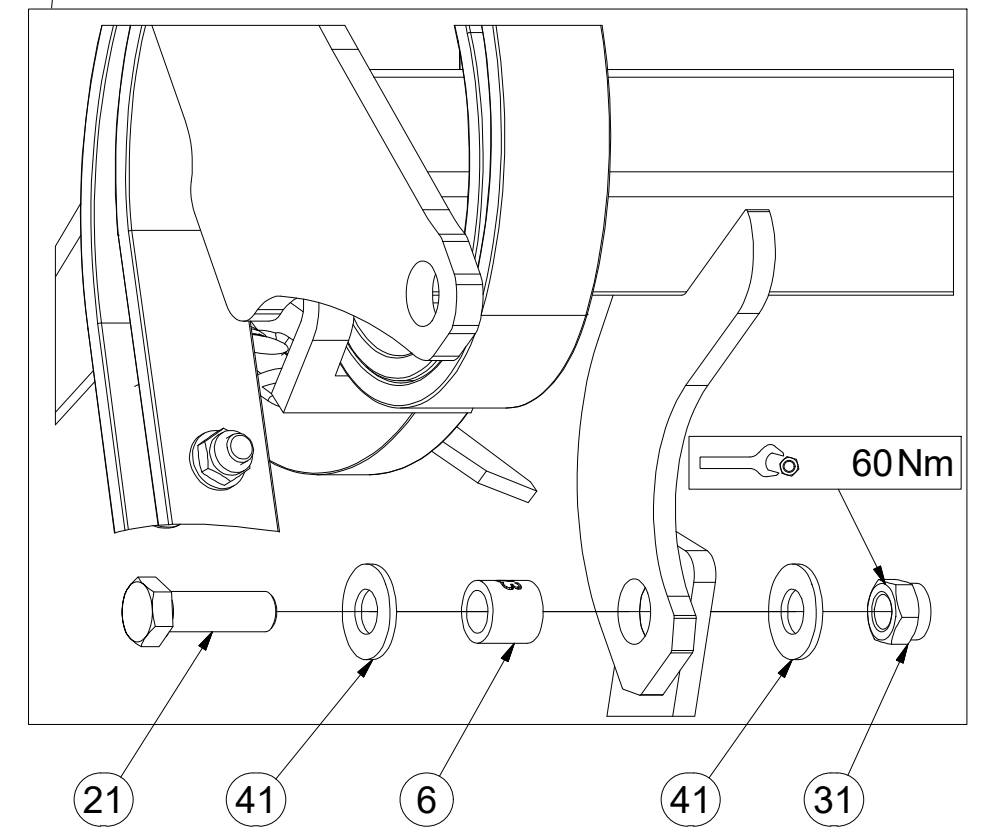
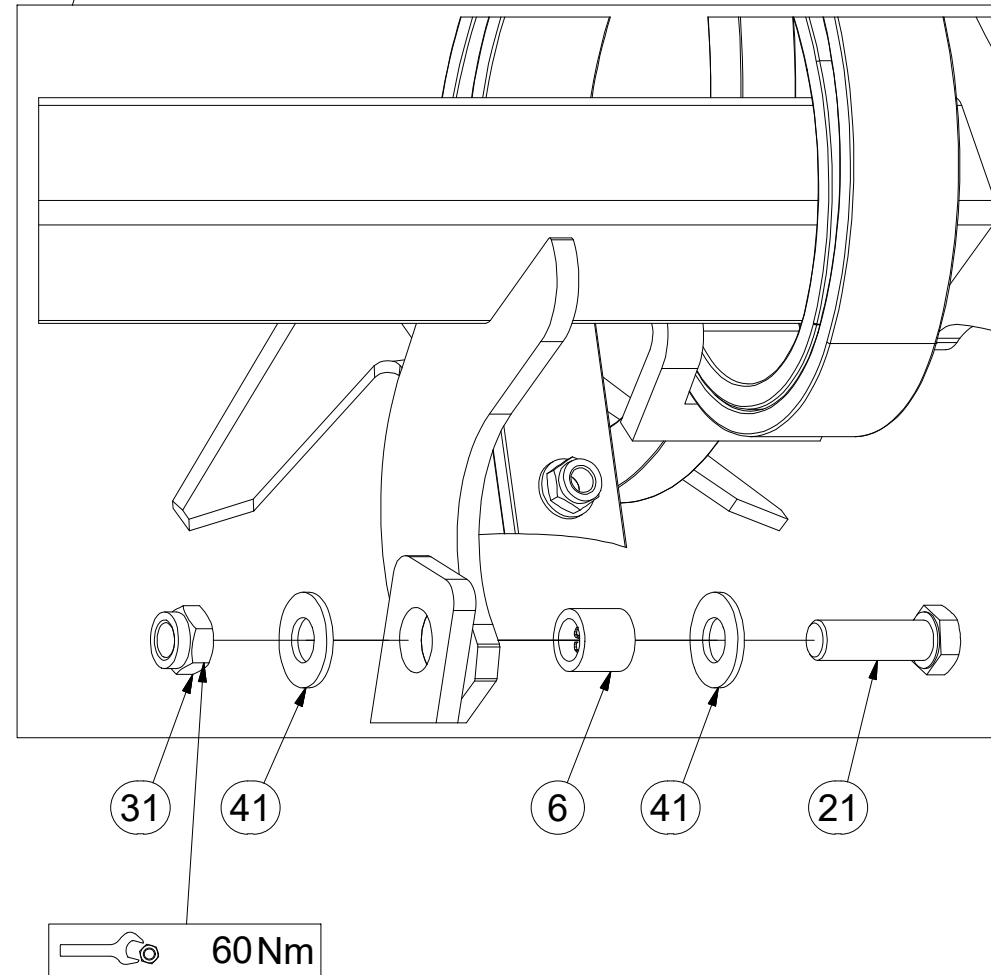
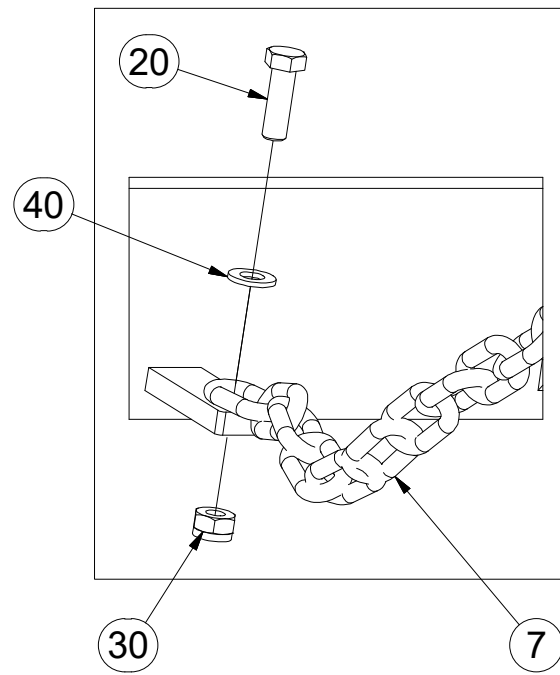
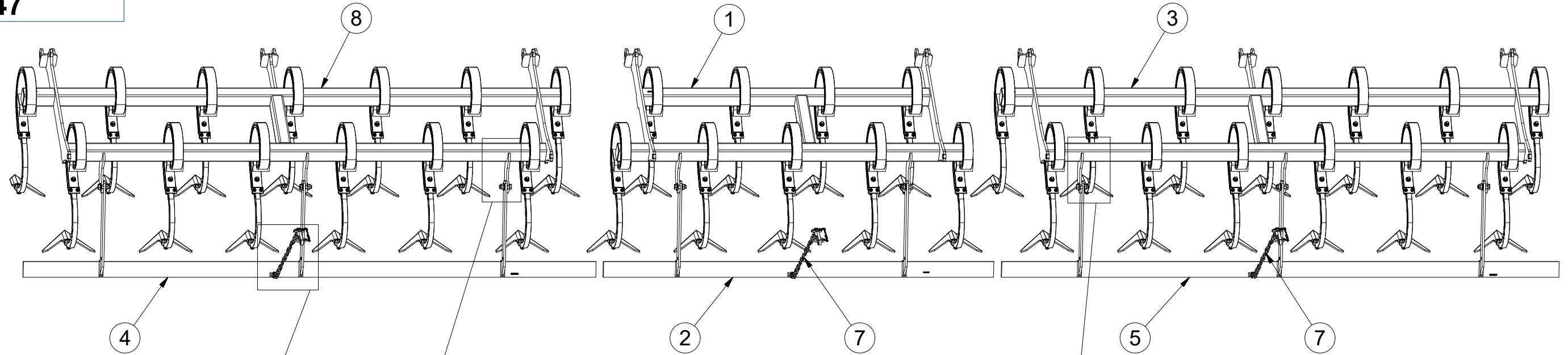

Pos.	Part Number	Pcs.	Pos.	Part Number	Pcs.
1	3002834	1	8	3007745	1
2	3002557	1	20	m01092	3
3	3007746	1	21	m04355	8
4	3002563	1	30	m04503	3
5	3002562	1	31	m03683	8
6	4022223	8	40	m01203	3
7	4001641	3	41	m05651	16

Ⓒ SADA RADLIC

Ⓓ SCHARSATZ

Ⓕ KIT DE SOCS

Ⓖ SET OF PLOUGHSHARES

Ⓡ КОМПЛЕКТ ЛАП

Ⓟ ZESTAW REDLIC



3002834

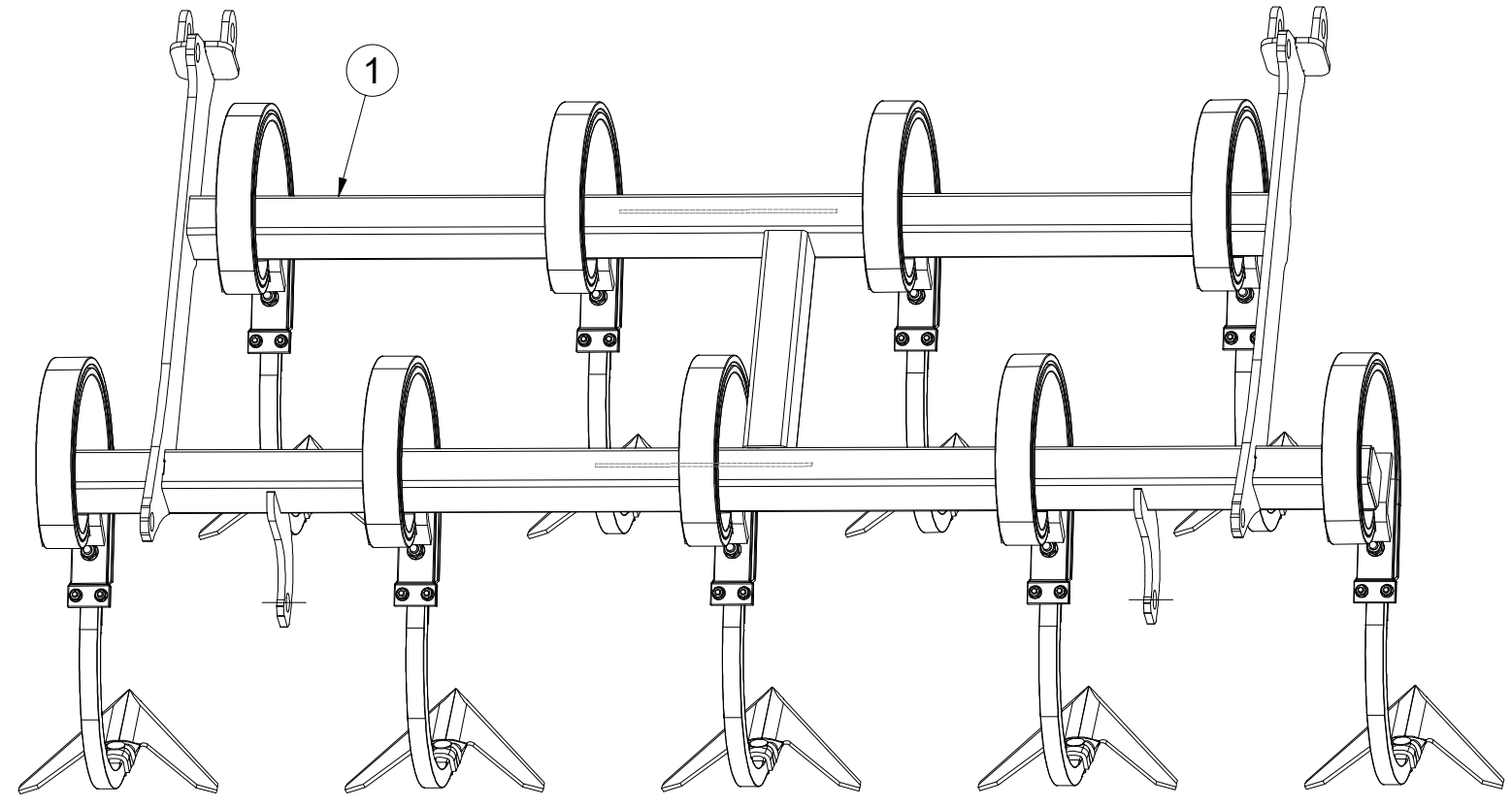
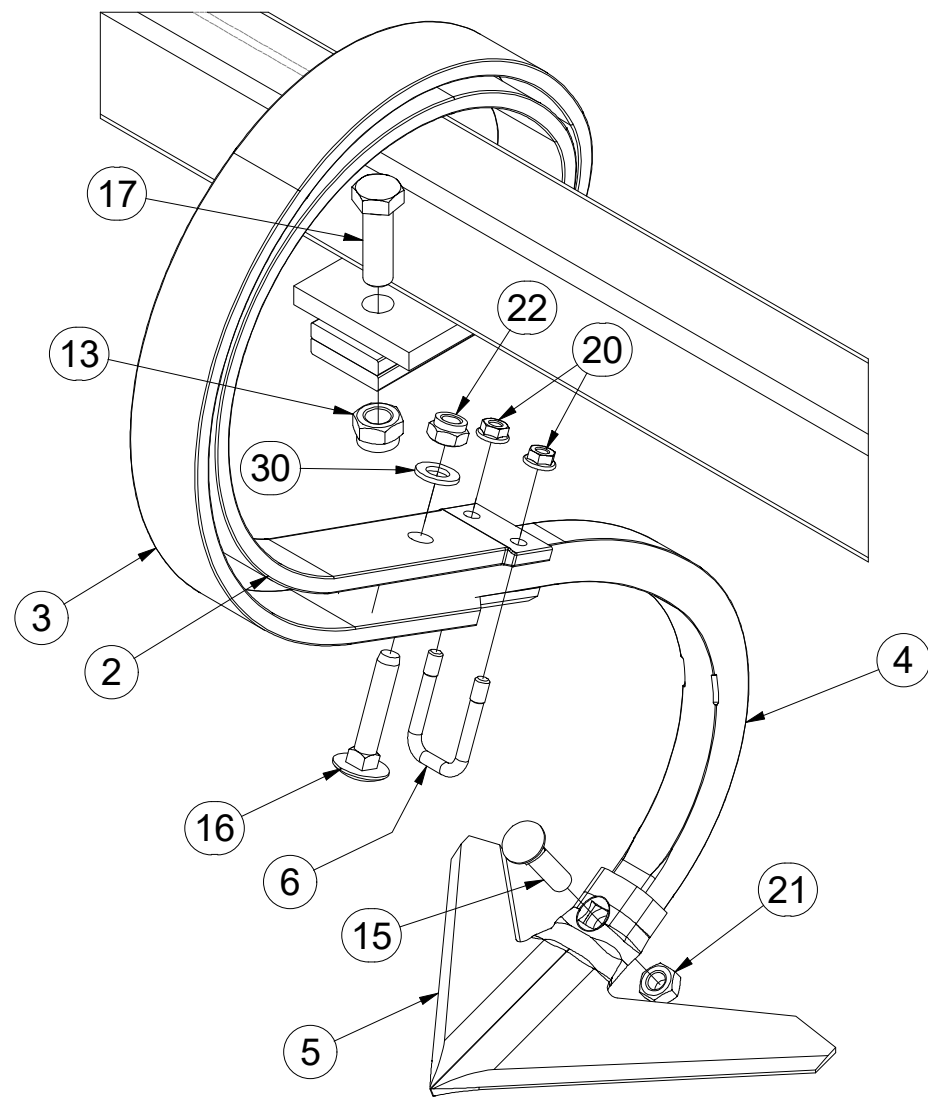
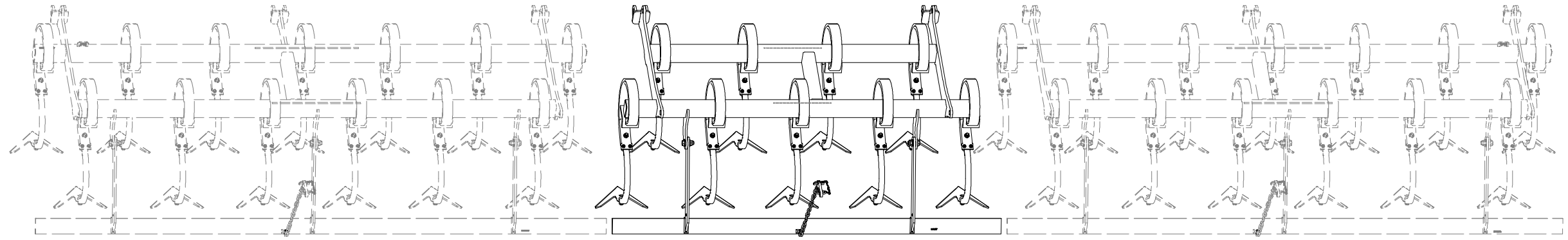

Pos.	Part Number	Pcs.
1	3010347	1
2	3000300	9
3	3000301	9
4	3002818	9
5	3000236-KOO	9
6	m09995	9
13	m03683	9
15	m10440	9
16	m11600	9
17	m04355	9
20	m06156	18
21	m10439	9
22	m04301	9
30	m01214	9

ⒸZ SADA RADLIC

Ⓓ SCHARSATZ

Ⓕ KIT DE SOCS

ⒸB SET OF PLOUGHSHARES

ⒸU КОМПЛЕКТ ЛАП

ⒸL ZESTAW REDLIC



3007745

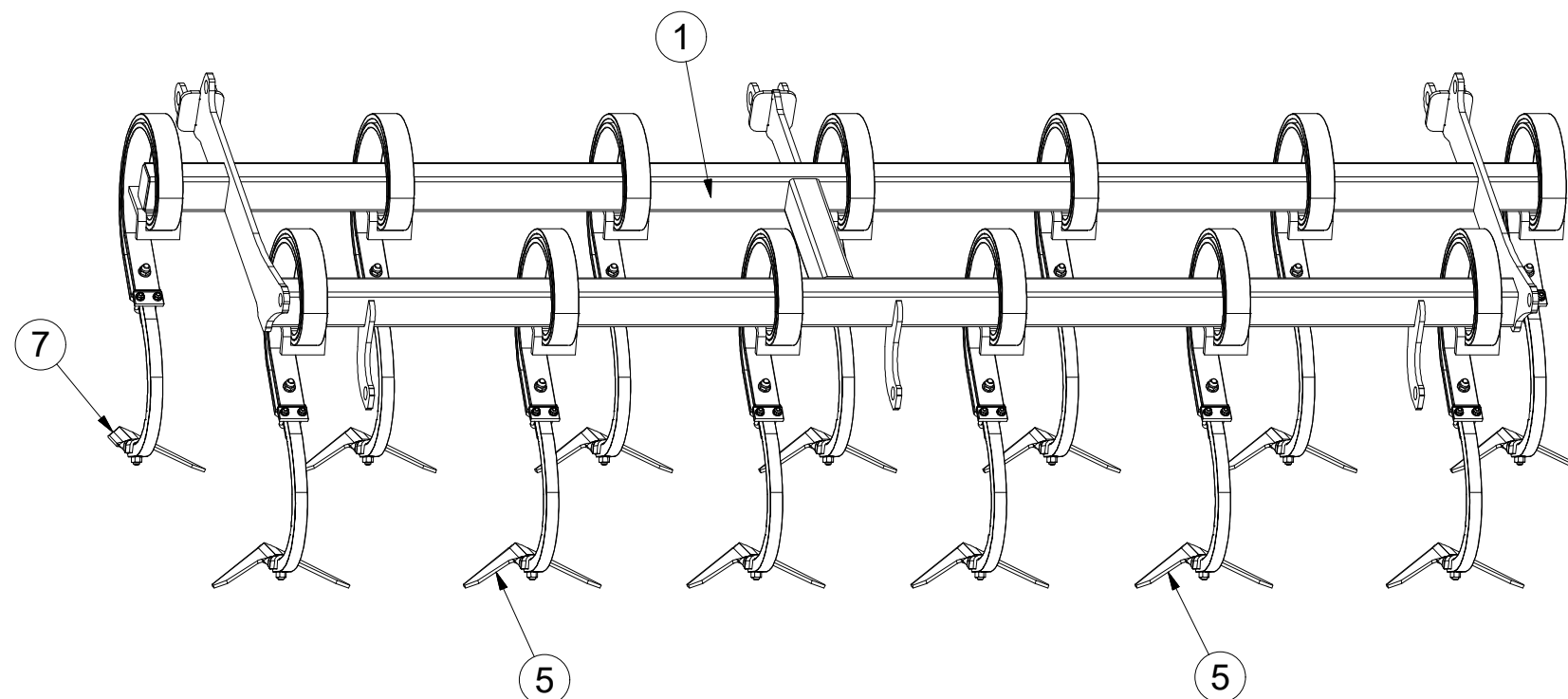
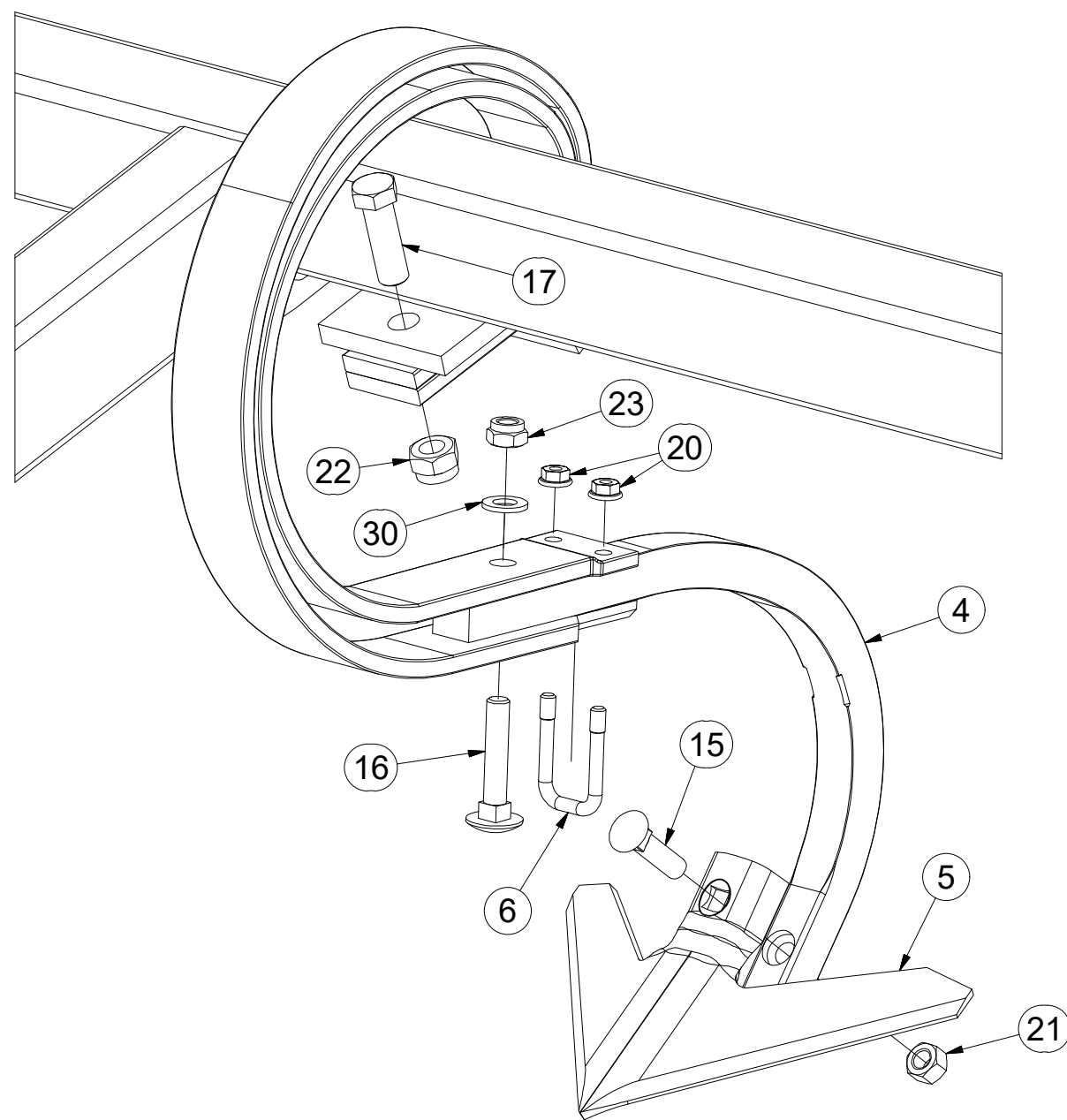
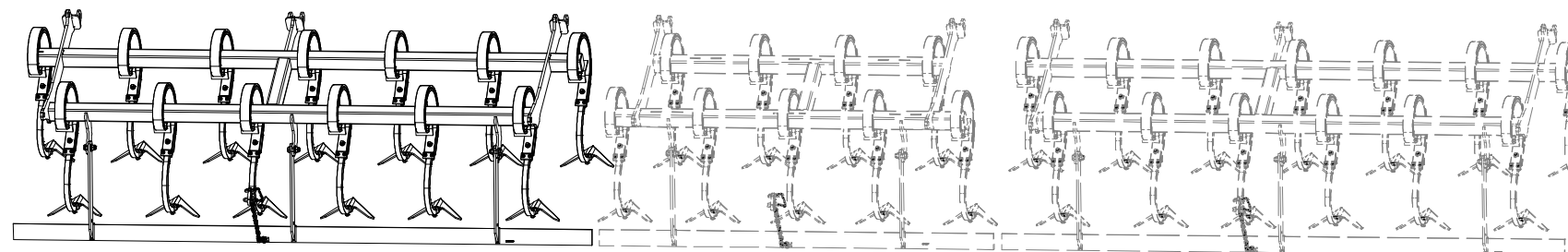

Pos.	Part Number	Pcs.	Pos.	Part Number	Pcs.
1	3010343	1	16	m11600	13
4	3002818	13	17	m04355	13
5	3000236-KOO	12	20	m06156	26
6	m09995	13	22	m03683	13
7	4007280	1	23	m04301	13
15	m10440	13	30	m01214	13

ⒸZ SADA RADLIC

Ⓓ SCHARSATZ

Ⓕ KIT DE SOCS

ⒼB SET OF PLOUGHSHARES

⒲U КОМПЛЕКТ ЛАП

⒲L ZESTAW REDLIC



3007746

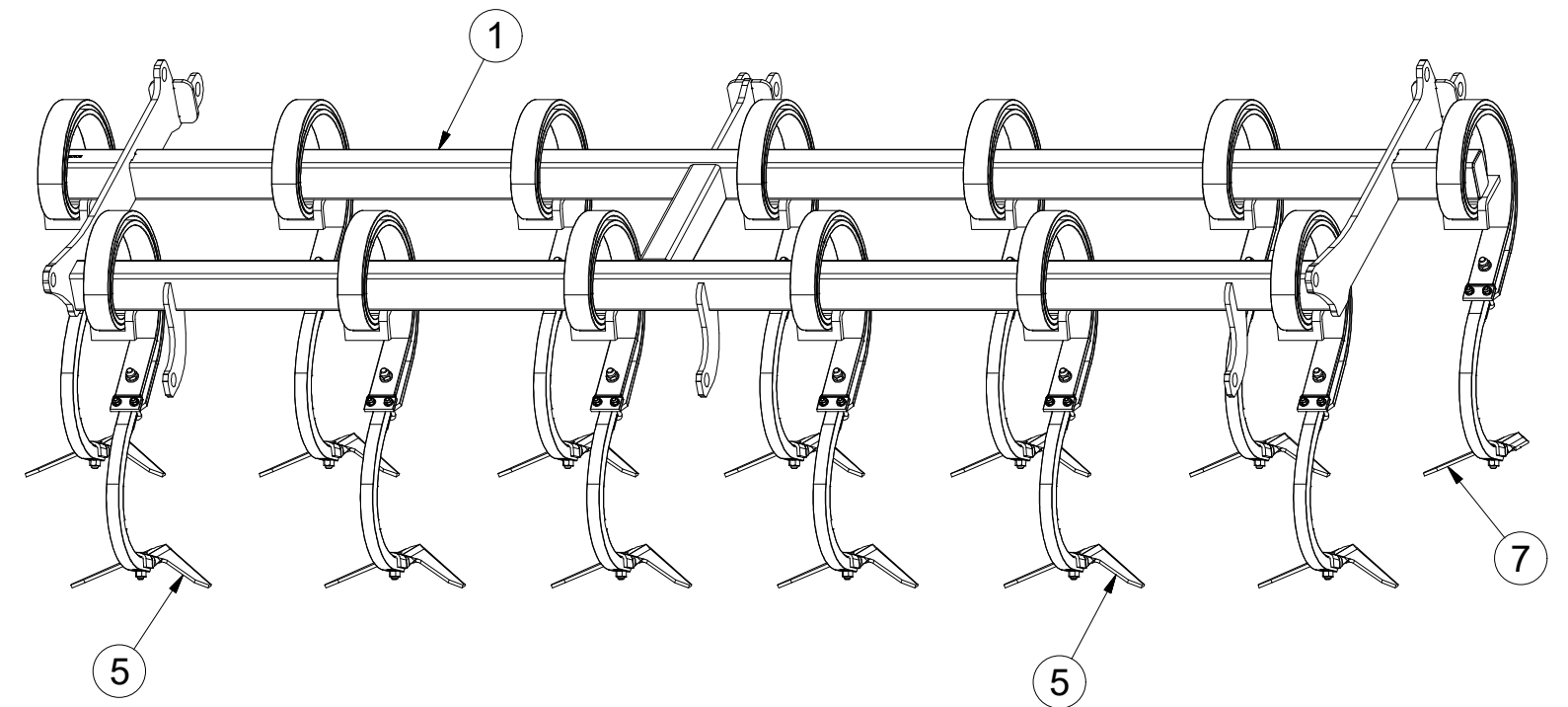
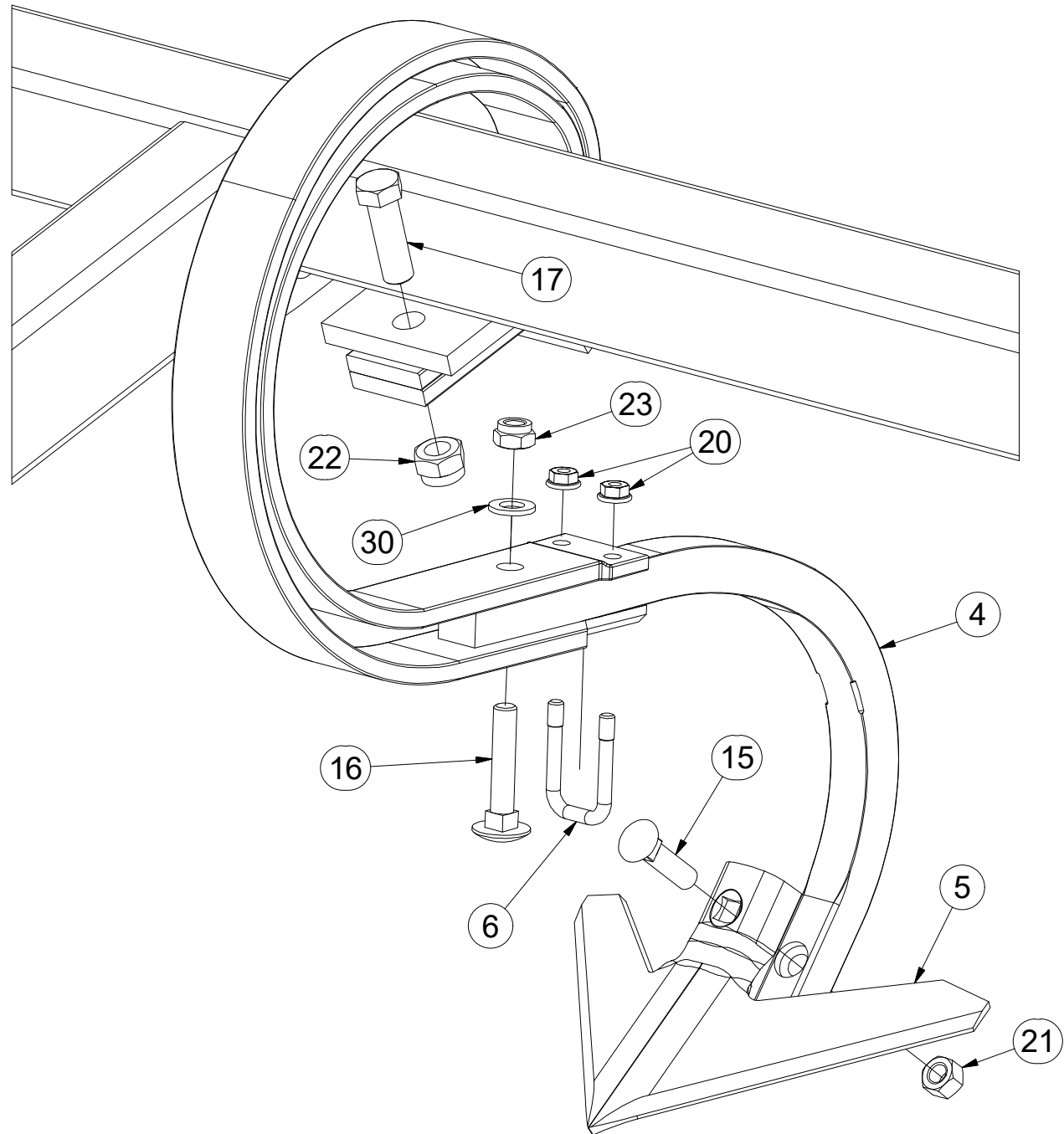
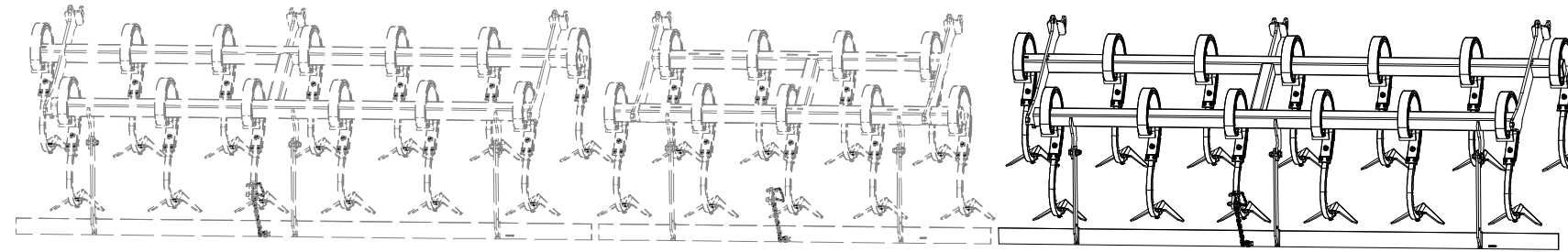

Pos.	Part Number	Pcs.	Pos.	Part Number	Pcs.
1	3010343	1	16	m11600	13
4	3002818	13	17	m04355	13
5	3000236-KOO	12	20	m06156	26
6	m09995	13	22	m03683	13
7	4007281	1	23	m04301	13
15	m10440	13	30	m01214	13

- Ⓒ SADA ZADNÍCH VÁLCŮ
- Ⓓ SATZ HINTERE WALZEN
- Ⓕ KIT DE ROULEAUX ARRIÈRE

- Ⓖ SET OF REAR ROLLERS
- Ⓡ КОМПЛЕКТ ЗАДНИХ КАТКОВ
- Ⓟ ZESTAW TYLNYCH WAŁÓW



VZ00019239

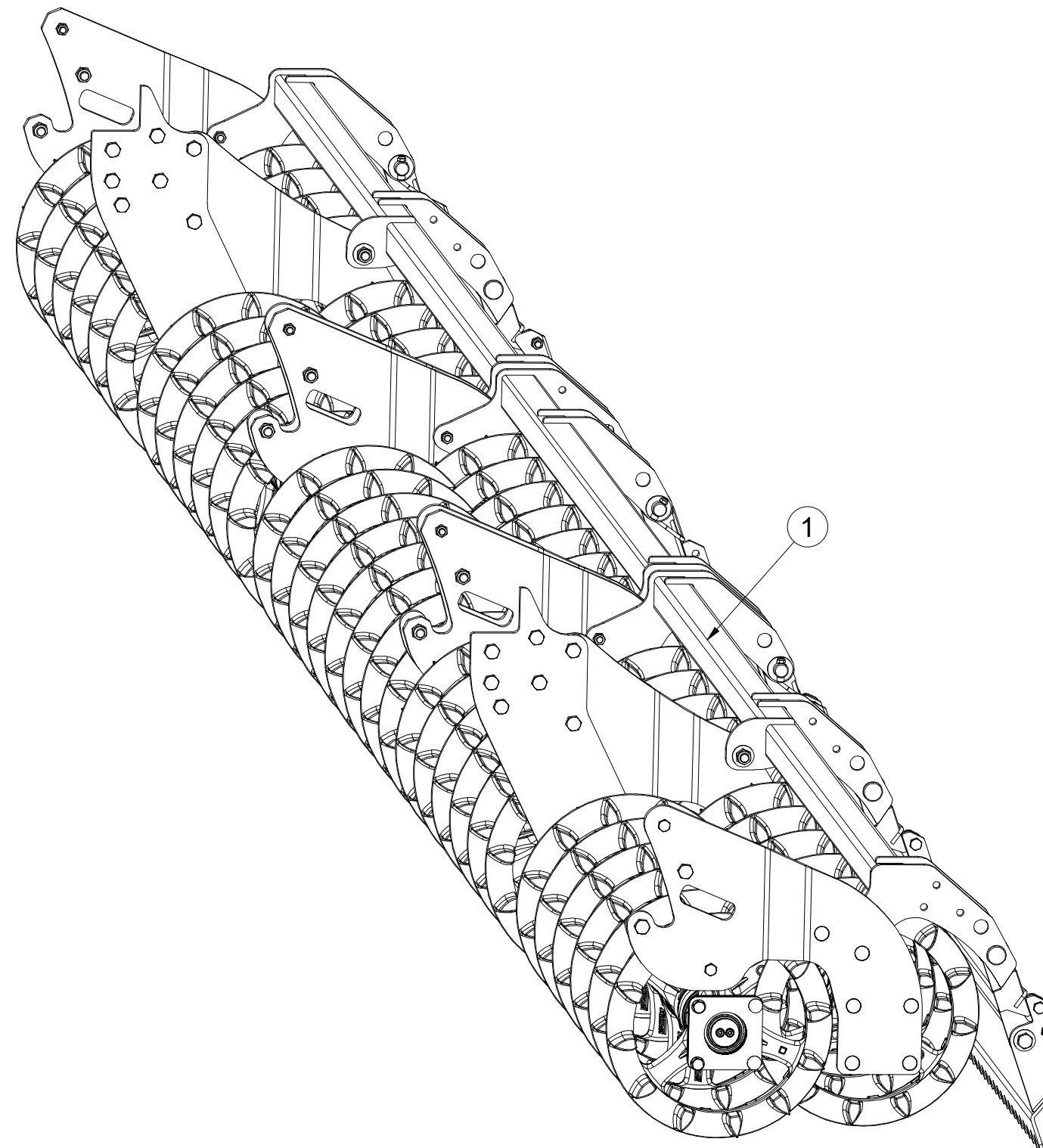
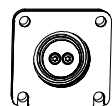
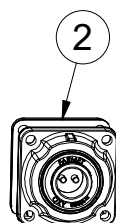
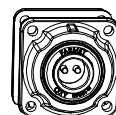

Pos.	Part Number	Pcs.
1	VZ00020214	1
2	VZ00012467	1

- Ⓒ SADA ZADNÍCH VÁLČŮ
- Ⓓ SATZ HINTERE WALZEN
- Ⓕ KIT DE ROULEAUX ARRIÈRE

- Ⓖ SET OF REAR ROLLERS
- Ⓡ КОМПЛЕКТ ЗАДНИХ КАТКОВ
- Ⓟ ZESTAW TYLNYCH WAŁÓW



VZ00020214

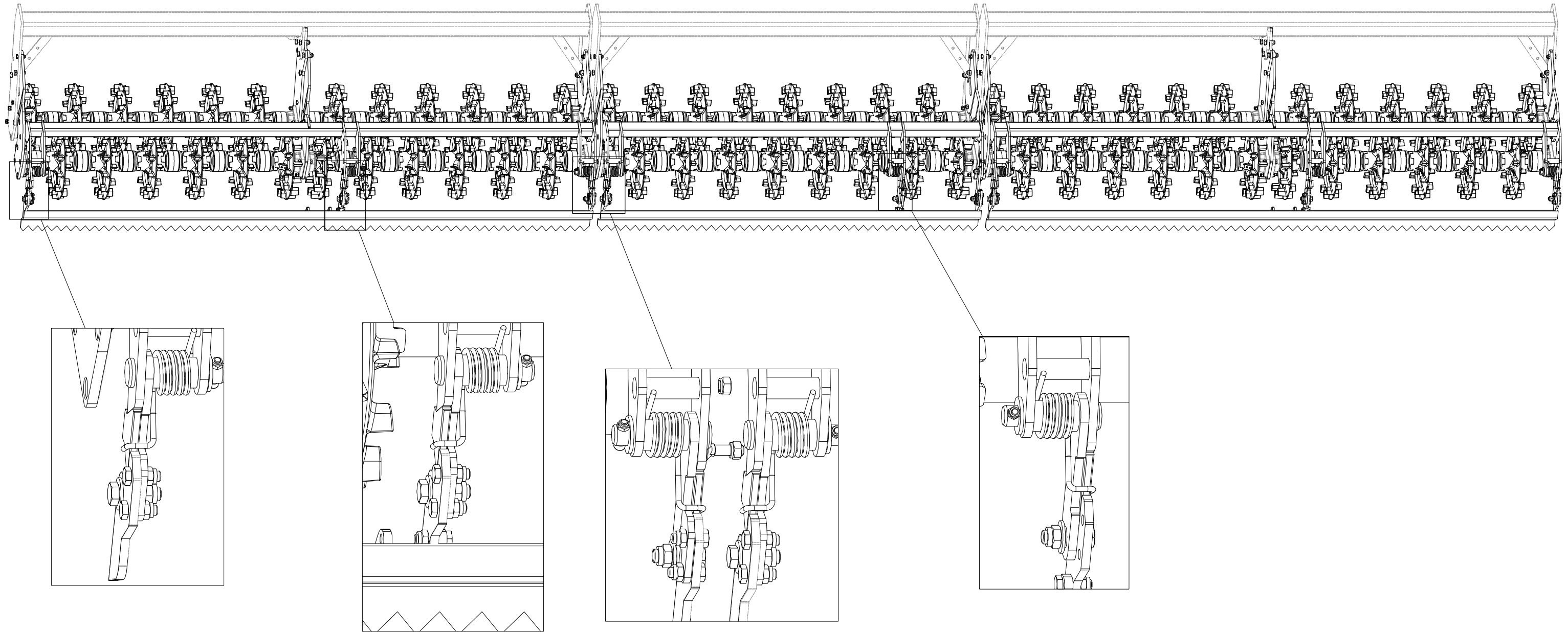

(CZ) SADA ZADNÍCH VÁLCŮ
 (D) SATZ HINTERE WALZEN
 (F) KIT DE ROULEAUX ARRIÈRE

(GB) SET OF REAR ROLLERS
 (RU) КОМПЛЕКТ ЗАДНИХ КАТКОВ
 (PL) ZESTAW TYLNYCH WAŁÓW



VZ00020214



B

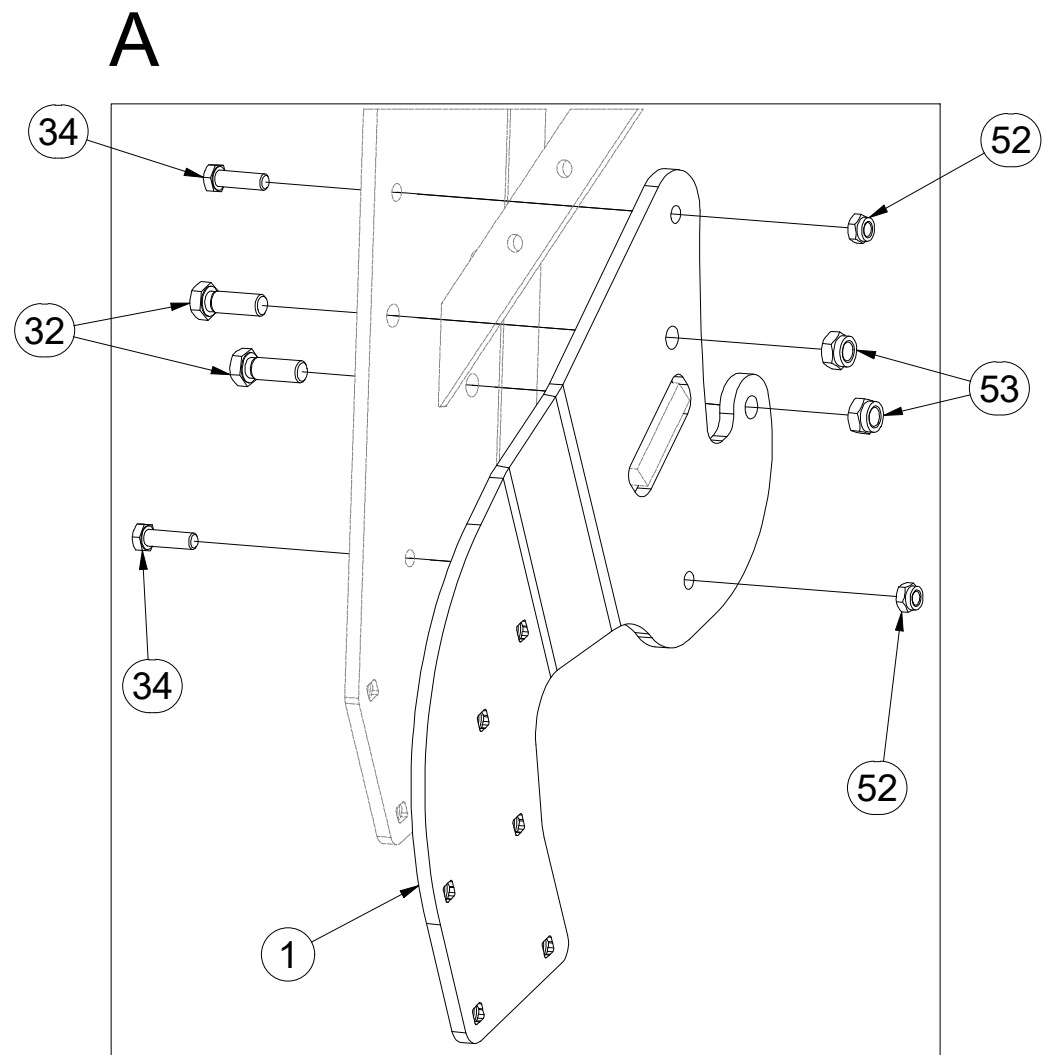

Pos.	Part Number	Pcs.
1	3009428	3
2	3009429	3
32	m02254	14
34	m15618	14
52	m04301	26
53	m03683	38

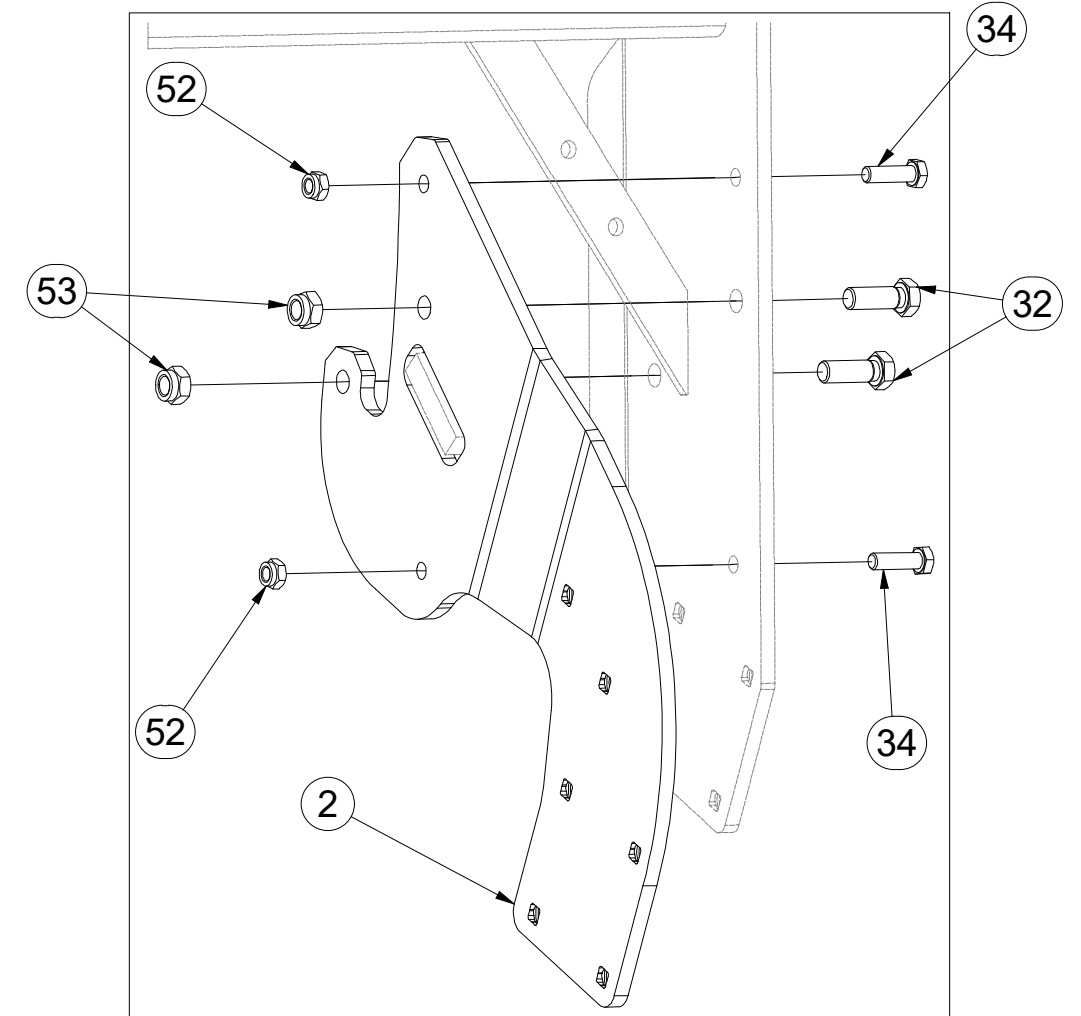

- ⒸZ SADA ZADNÍCH VÁLCŮ
- Ⓓ SATZ HINTERE WALZEN
- Ⓕ KIT DE ROULEAUX ARRIÈRE

- ⒸB SET OF REAR ROLLERS
- ⒸR КОМПЛЕКТ ЗАДНИХ КАТКОВ
- ⒸL ZESTAW TYLNYCH WAŁÓW



VZ00020214

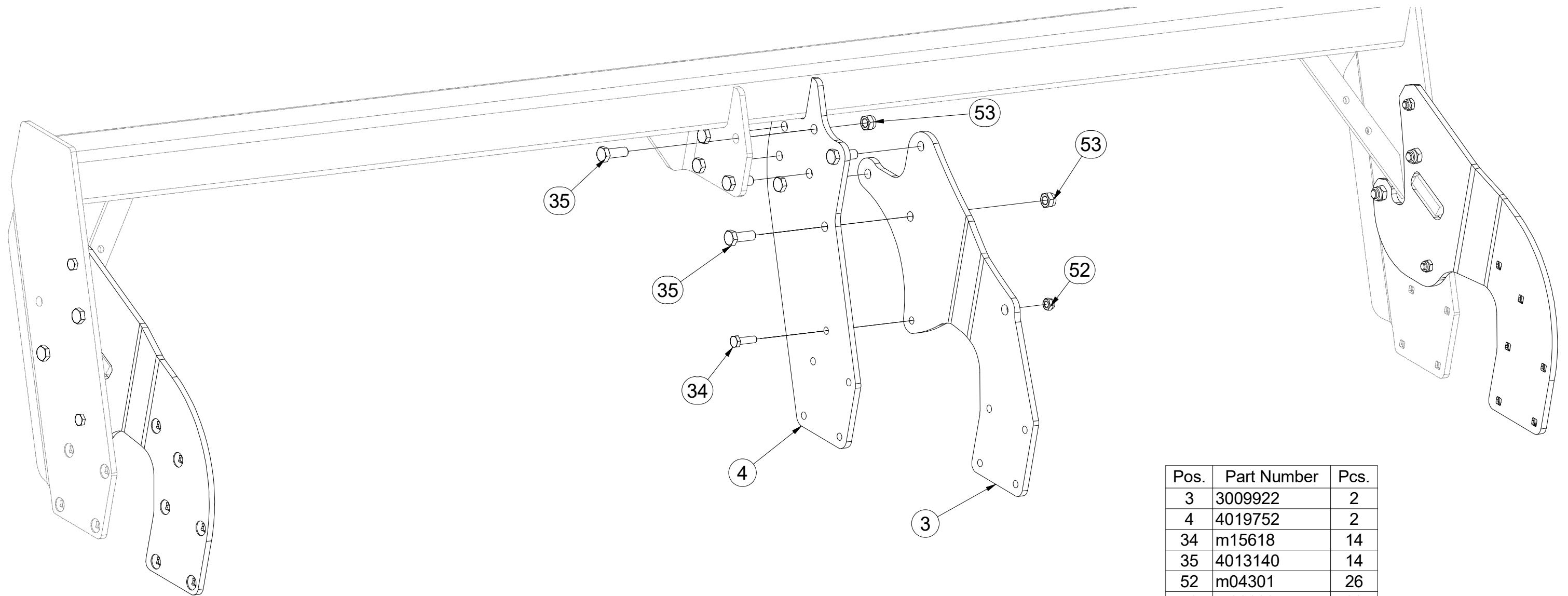
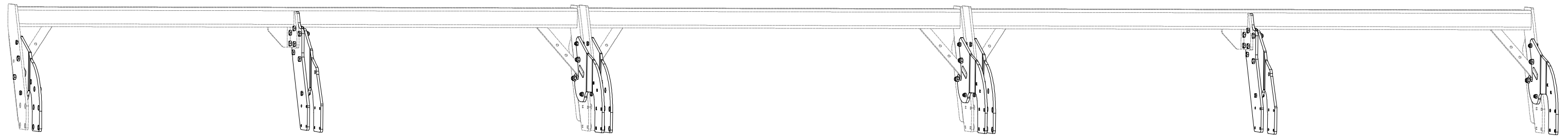

Pos.	Part Number	Pcs.
3	3009922	2
4	4019752	2
34	m15618	14
35	4013140	14
52	m04301	26
53	m03683	38

- Ⓒ SADA ZADNÍCH VÁLČŮ
- Ⓓ SATZ HINTERE WALZEN
- Ⓕ KIT DE ROULEAUX ARRIÈRE

- Ⓖ SET OF REAR ROLLERS
- Ⓡ КОМПЛЕКТ ЗАДНИХ КАТКОВ
- Ⓟ ZESTAW TYLNYCH WAŁÓW



VZ00020214

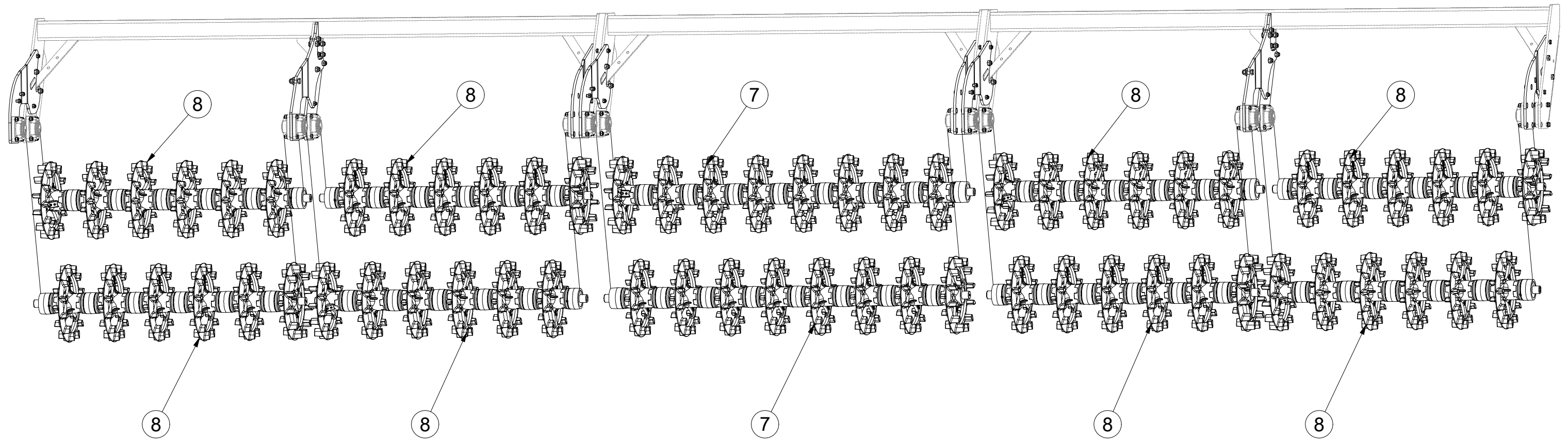

Pos.	Part Number	Pcs.
7	VZ00020119	2
8	VZ00020216	8

- ⒸZ SADA ZADNÍCH VÁLČŮ
- Ⓓ SATZ HINTERE WALZEN
- Ⓕ KIT DE ROULEAUX ARRIÈRE

- ⒼB SET OF REAR ROLLERS
- ⒶR КОМПЛЕКТ ЗАДНИХ КАТКОВ
- ⒶL ZESTAW TYLNYCH WAŁÓW



VZ00020214

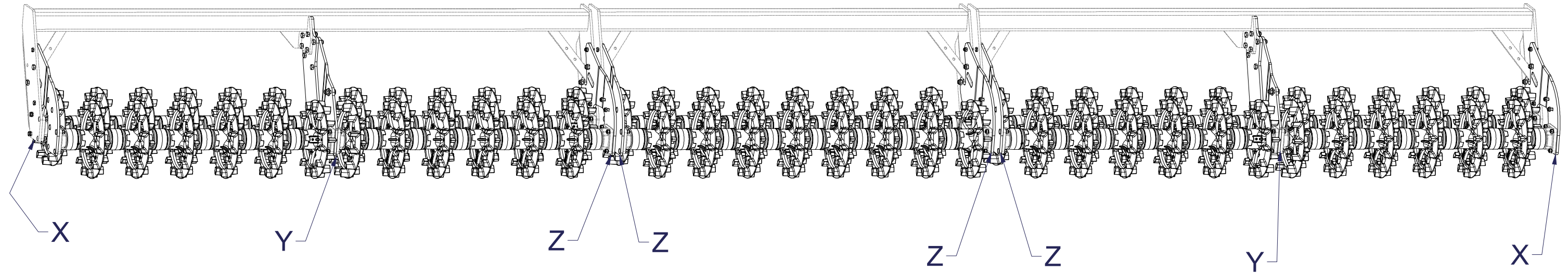

Pos.	Part Number	Pcs.
30	m03519	44
36	m05898	16
37	m04412	4
50	m01305	66
60	m03988	66
61	m17741	4

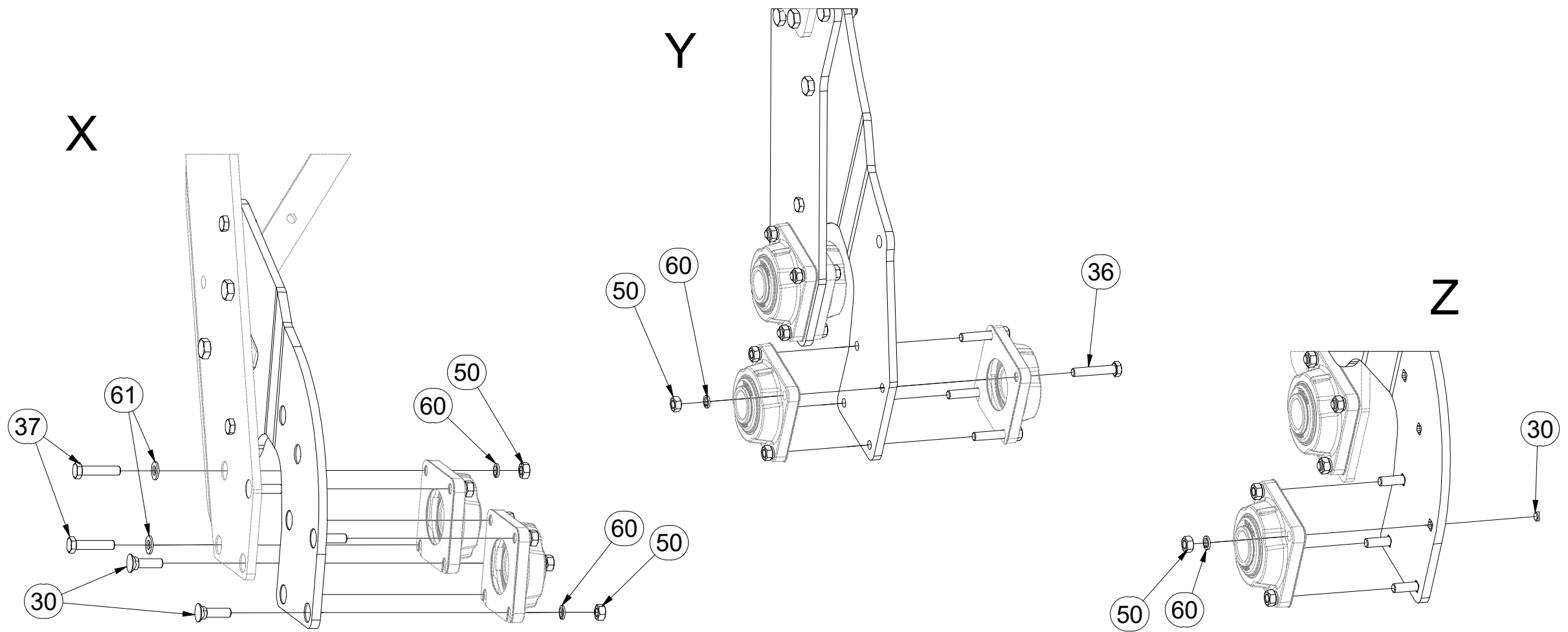

- ⒸZ SADA ZADNÍCH VÁLČŮ
- Ⓓ SATZ HINTERE WALZEN
- Ⓕ KIT DE ROULEAUX ARRIÈRE

- ⒼB SET OF REAR ROLLERS
- ⒶR КОМПЛЕКТ ЗАДНИХ КАТКОВ
- ⒶL ZESTAW TYLNYCH WAŁÓW



VZ00020214

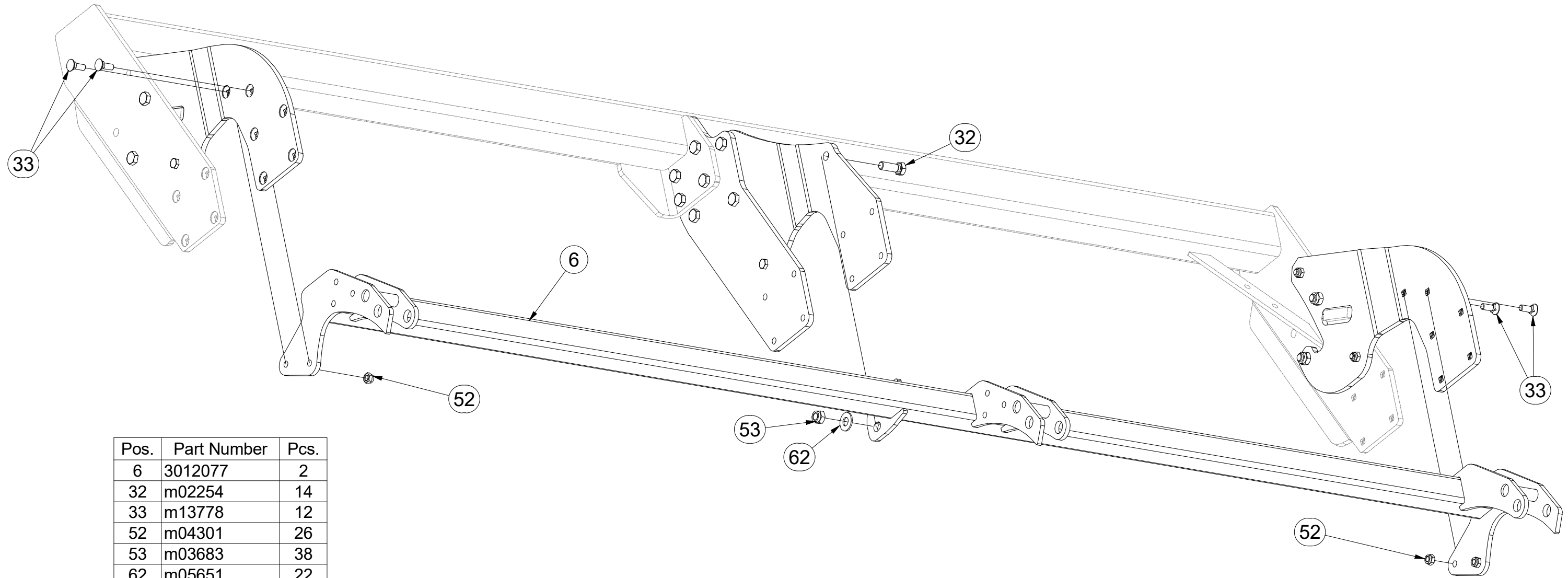
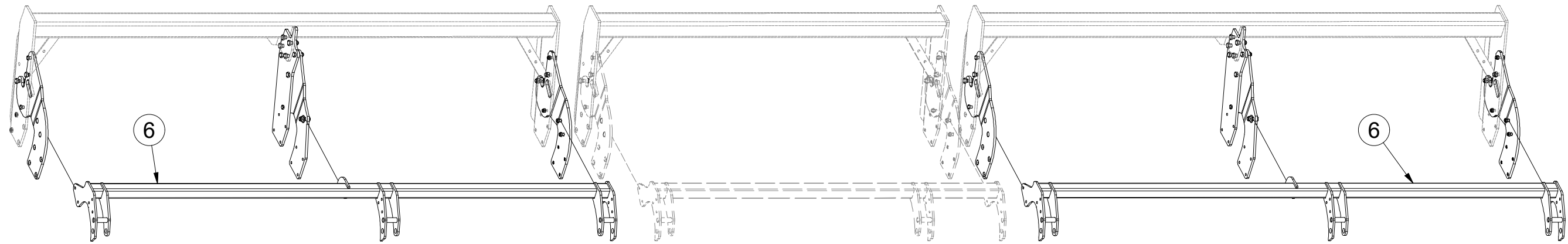

Pos.	Part Number	Pcs.
6	3012077	2
32	m02254	14
33	m13778	12
52	m04301	26
53	m03683	38
62	m05651	22

- Ⓒ SADA ZADNÍCH VÁLCŮ
- Ⓓ SATZ HINTERE WALZEN
- Ⓕ KIT DE ROULEAUX ARRIÈRE

- Ⓖ SET OF REAR ROLLERS
- Ⓡ КОМПЛЕКТ ЗАДНИХ КАТКОВ
- Ⓟ ZESTAW TYLNYCH WAŁÓW



VZ00020214

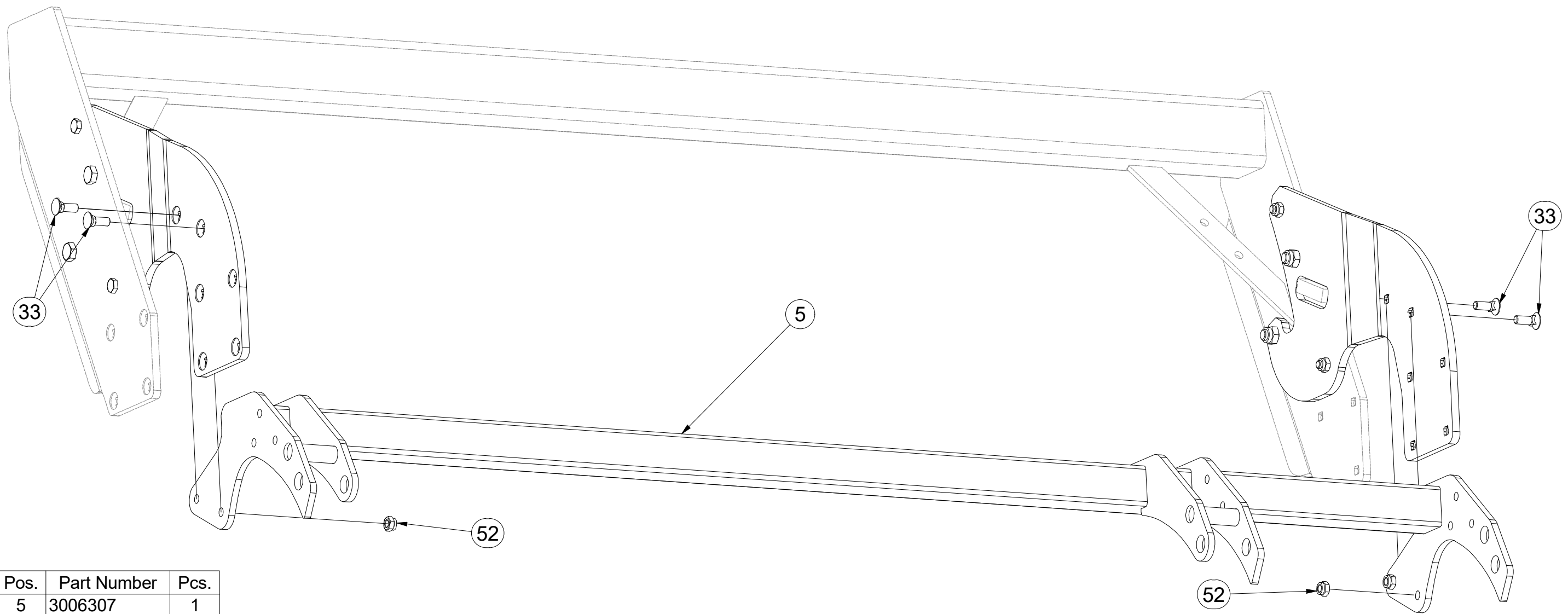
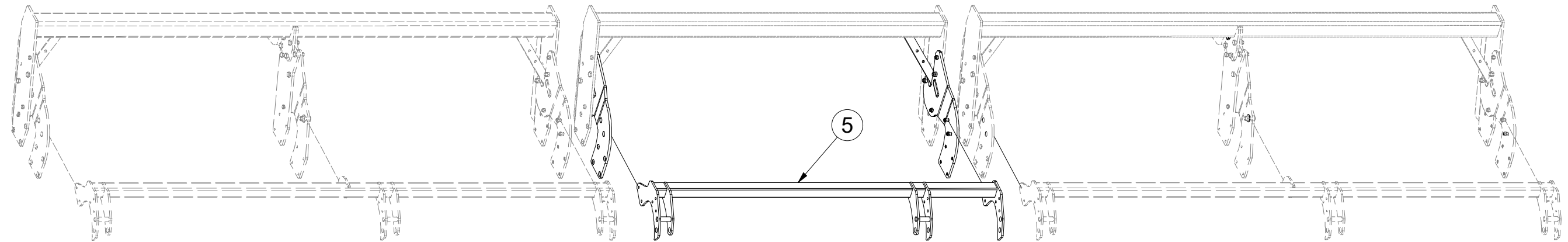

Pos.	Part Number	Pcs.
5	3006307	1
33	m13778	12
52	m04301	26

- ⒸZ SADA ZADNÍCH VÁLCŮ
- Ⓓ SATZ HINTERE WALZEN
- Ⓕ KIT DE ROULEAUX ARRIÈRE

- ⒼB SET OF REAR ROLLERS
- ⒺU КОМПЛЕКТ ЗАДНИХ КАТКОВ
- ⒺL ZESTAW TYLNYCH WAŁÓW



VZ00020214

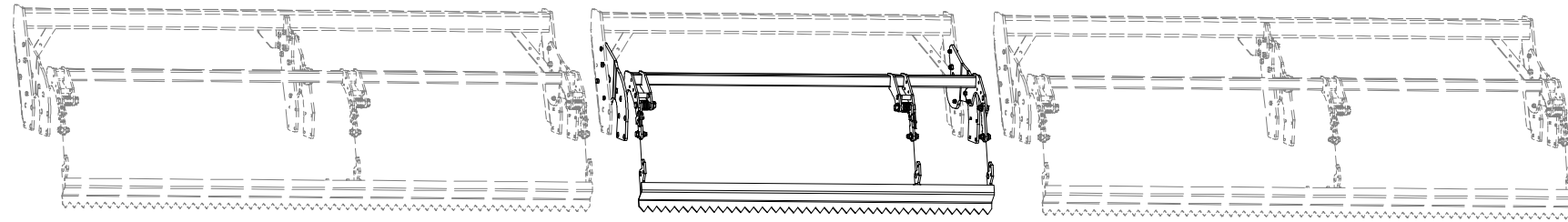

Pos.	Part Number	Pcs.	Pos.	Part Number	Pcs.
9	VZ00018654	1	17	m12304	5
11	4024903	8	31	m09464	8
12	9003659	1	38	m04355	10
13	9002979	8	51	m04503	8
14	4015778	8	53	m03683	38
15	4022223	10	62	m05651	22
16	m12303	3	63	m14028	8

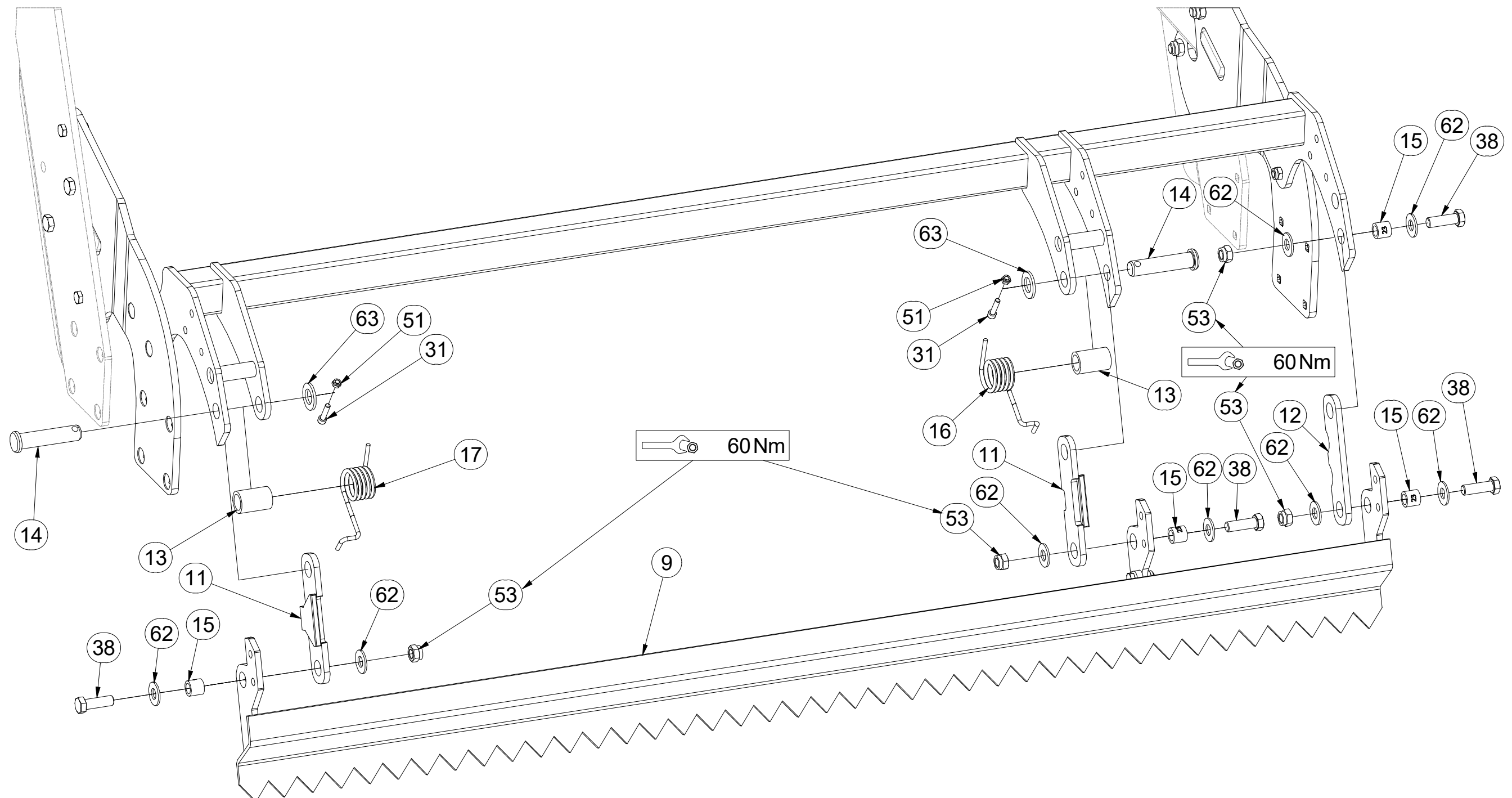

- CZ SADA ZADNÍCH VÁLČŮ
 D SATZ HINTERE WALZEN
 F KIT DE ROULEAUX ARRIÈRE

- GB SET OF REAR ROLLERS
 RU КОМПЛЕКТ ЗАДНИХ КАТКОВ
 PL ZESTAW TYLNYCH WAŁÓW



VZ00020214

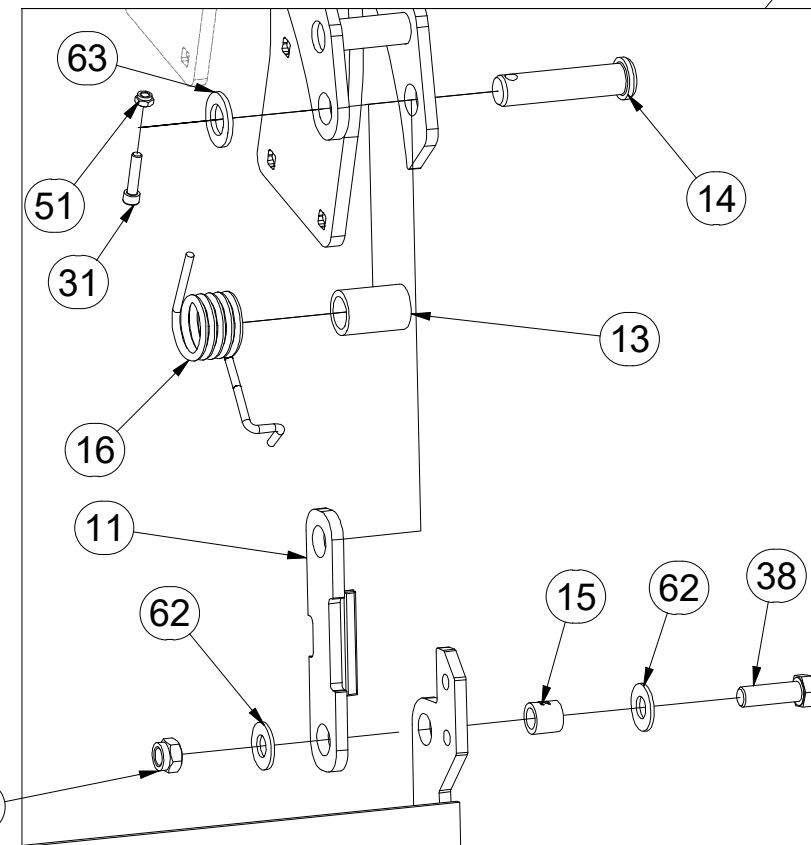
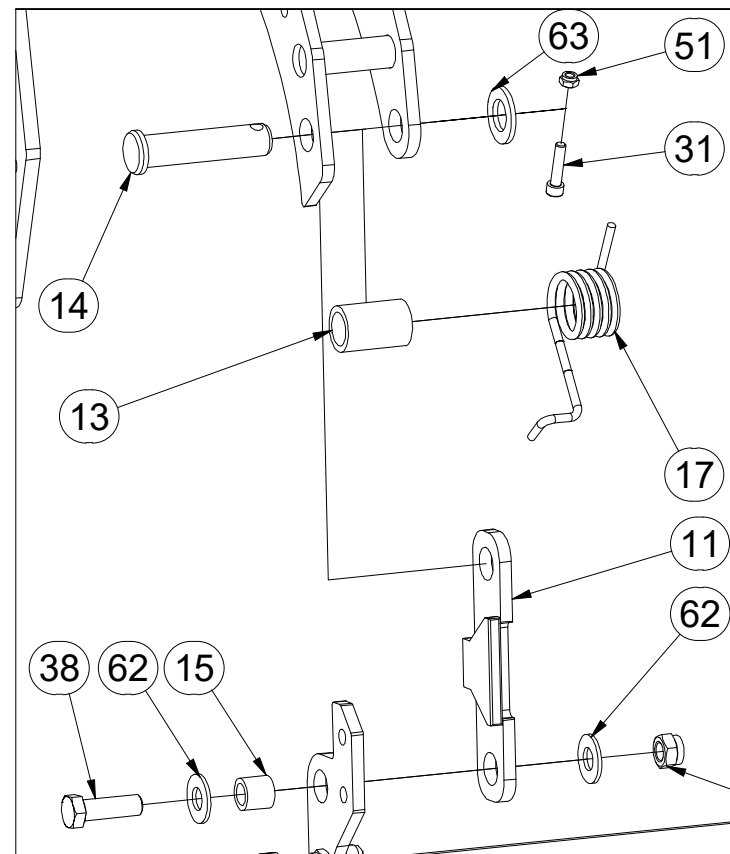
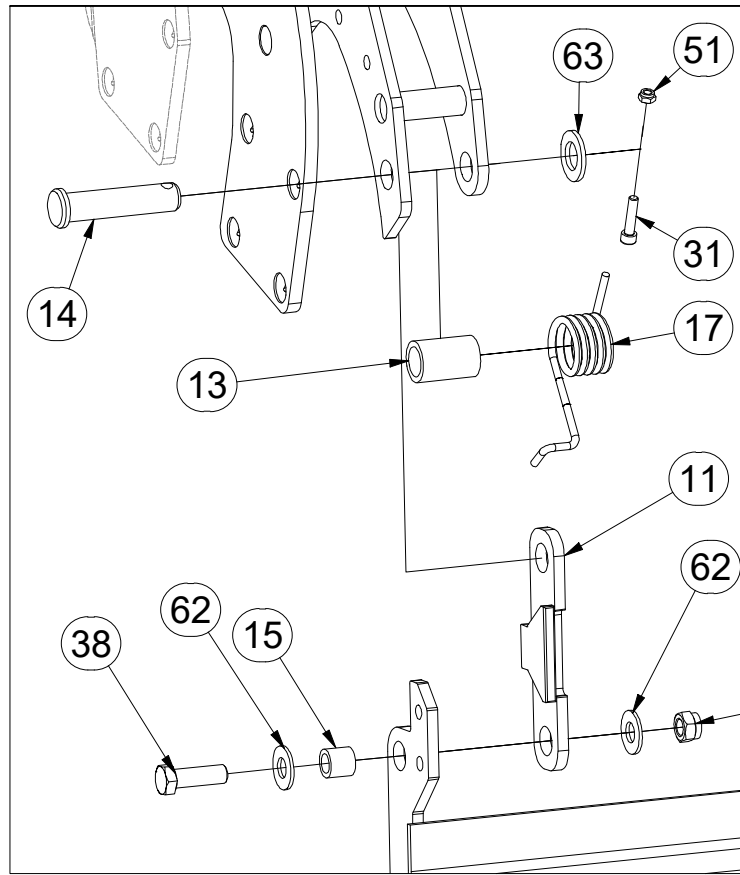
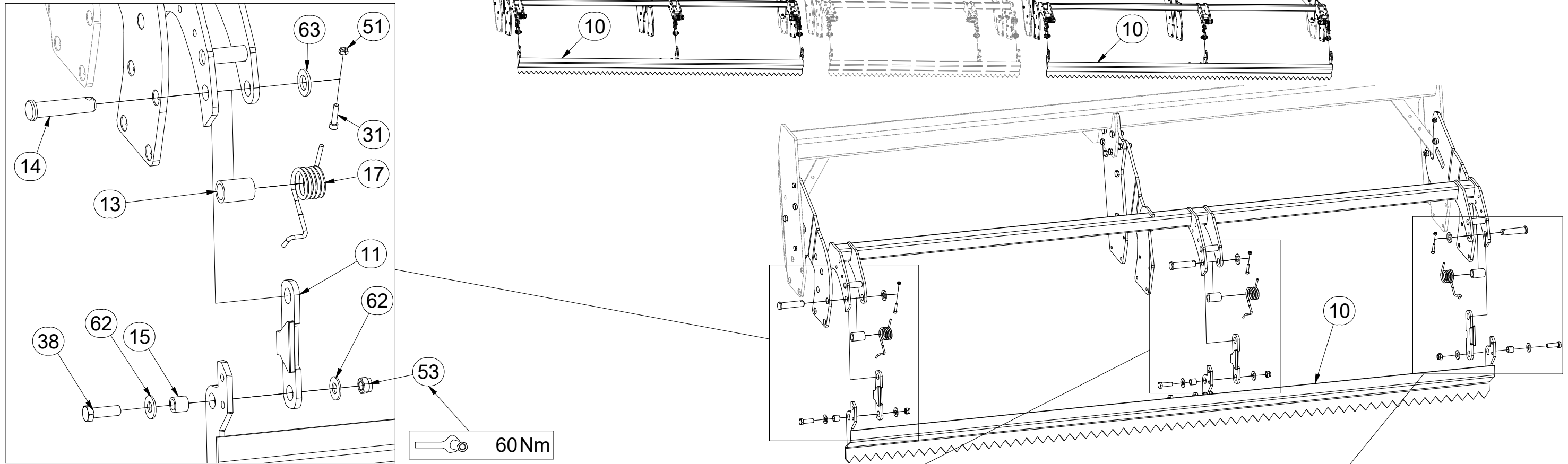

Pos.	Part Number	Pcs.
10	VZ00019831	2
11	4024903	8
13	9002979	8
14	4015778	8
15	4022223	10
16	m12303	3
17	m12304	5
31	m09464	8
38	m04355	10
51	m04503	8
53	m03683	38
62	m05651	22
63	m14028	8

- ⒸZ SADA ZADNÍCH VÁLCŮ
- Ⓓ SATZ HINTERE WALZEN
- Ⓕ KIT DE ROULEAUX ARRIÈRE

- ⒸB SET OF REAR ROLLERS
- ⒸU КОМПЛЕКТ ЗАДНИХ КАТКОВ
- ⒸL ZESTAW TYLNYCH WAŁÓW



VZ00020214

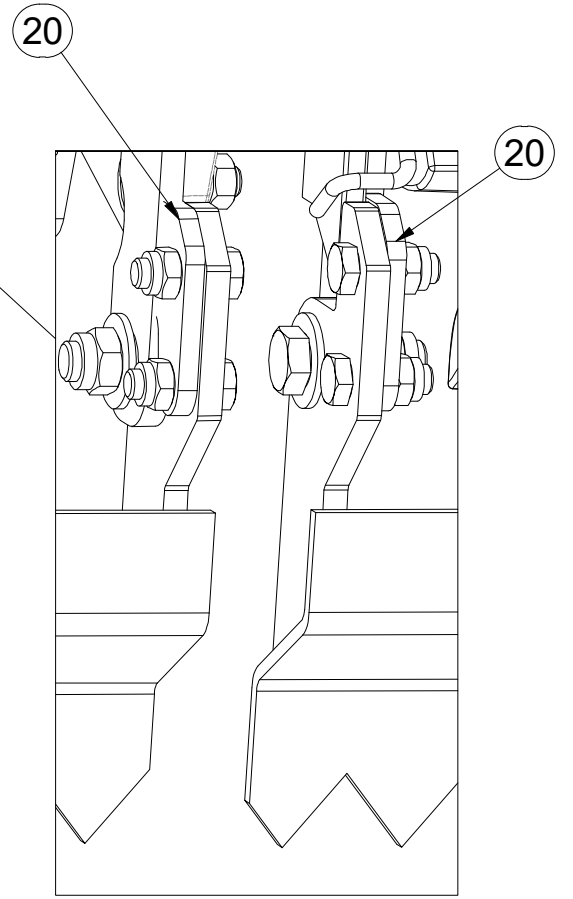
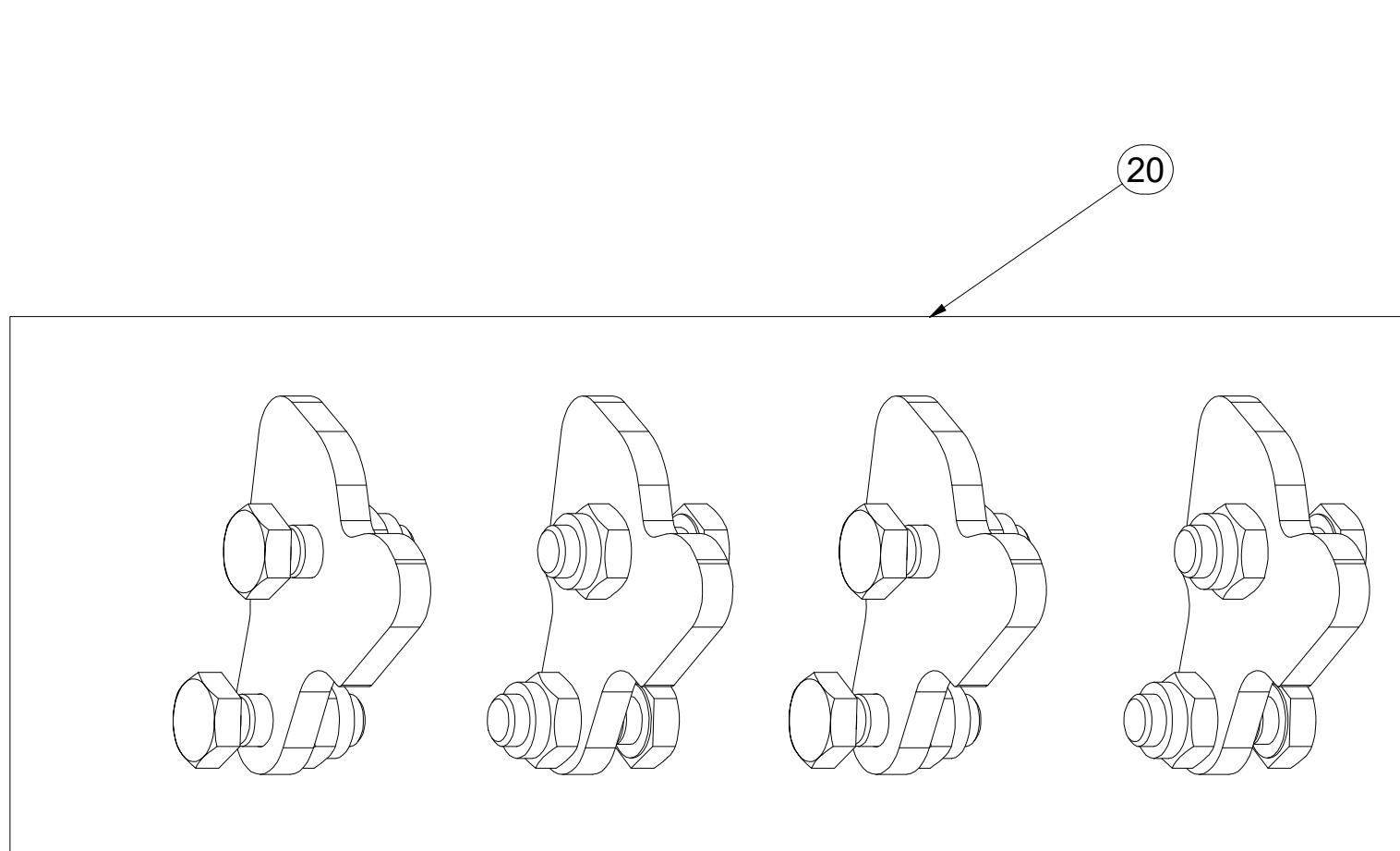
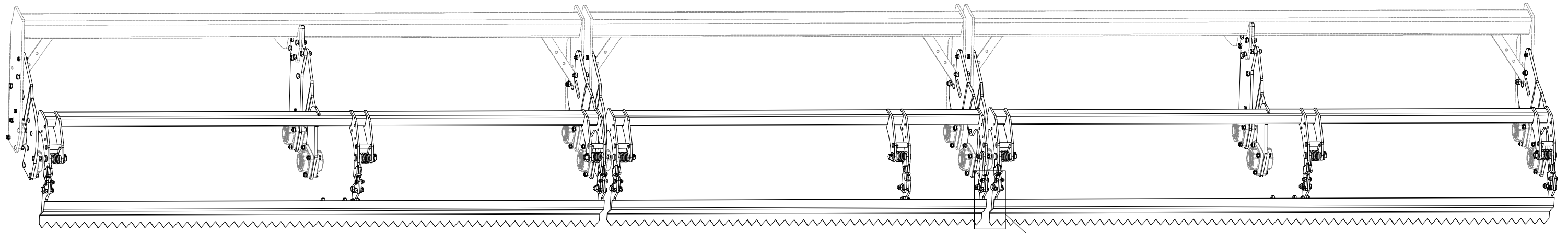

Pos.	Part Number	Pcs.
20	VZ00012931	1

CZ SADA ZADNÍCH VÁLCŮ
 D SATZ HINTERE WALZEN
 F KIT DE ROULEAUX ARRIÈRE

GB SET OF REAR ROLLERS
 RU КОМПЛЕКТ ЗАДНИХ КАТКОВ
 PL ZESTAW TYLNYCH WAŁÓW



VZ00020119

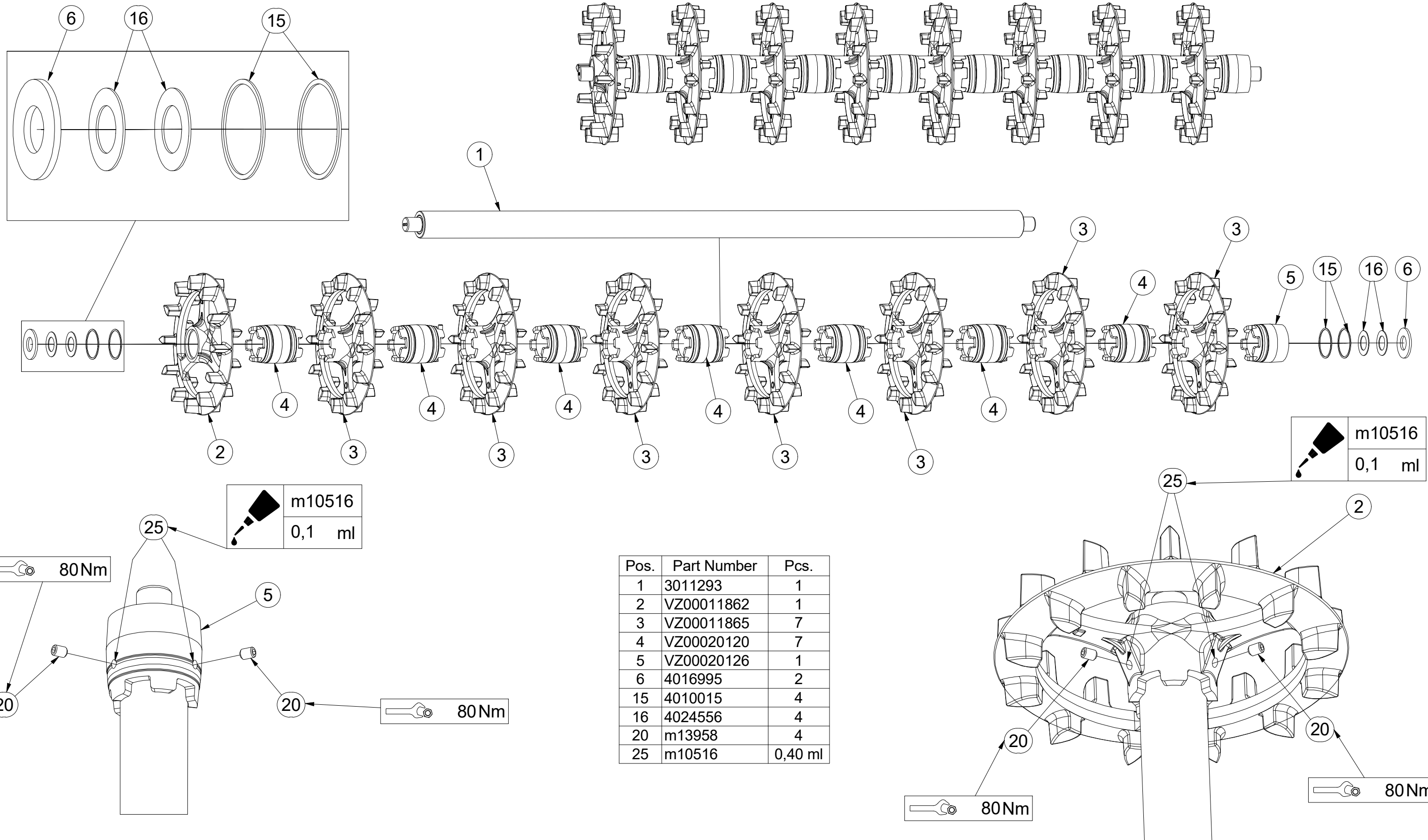

Pos.	Part Number	Pcs.
1	3011293	1
2	VZ00011862	1
3	VZ00011865	7
4	VZ00020120	7
5	VZ00020126	1
6	4016995	2
15	4010015	4
16	4024556	4
20	m13958	4
25	m10516	0,40 ml

CZ SADA ZADNÍCH VÁLCŮ
 D SATZ HINTERE WALZEN
 F KIT DE ROULEAUX ARRIÈRE

GB SET OF REAR ROLLERS
 RU КОМПЛЕКТ ЗАДНИХ КАТКОВ
 PL ZESTAW TYLNYCH WAŁÓW



VZ00020216

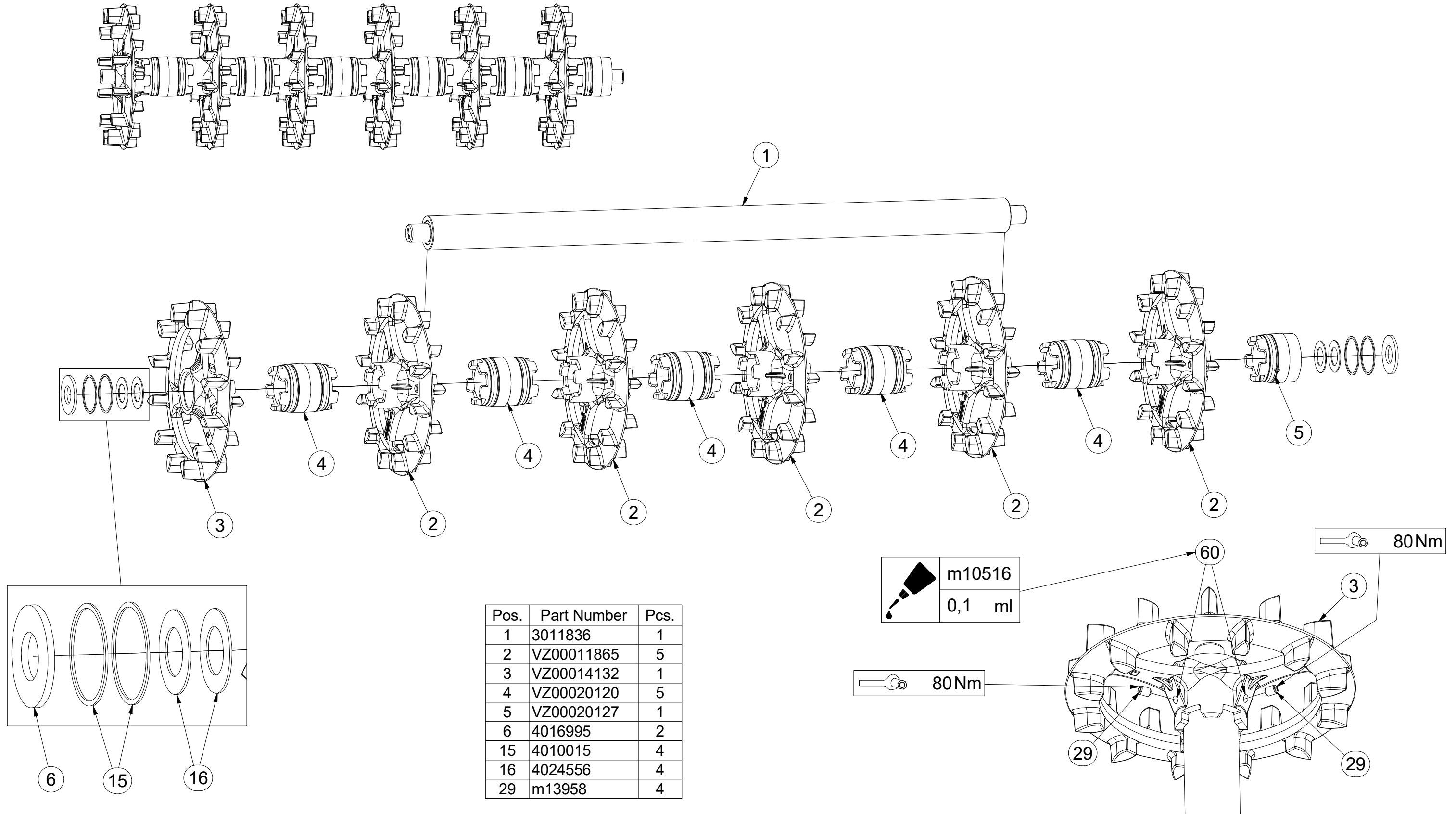

Ⓒ SMYKY ZADNÍCH VÁLCŮ

Ⓓ SCHLEIFE HINTERE WALZE

Ⓕ NIVELEUR ARRIÈRE ROULEAUX

VZ00019831

Ⓖ DRAG REAR ROLLERS

Ⓡ ПЛАНКИ ЗАДНИХ КАТКОВ

Ⓟ WŁÓKY TYLNYCH WAŁOW

Farmet

Pos.	Part Number	Pcs.
1	VZ00019830	1
2	VZ00014941	1
10	m04343	2
15	m04301	2

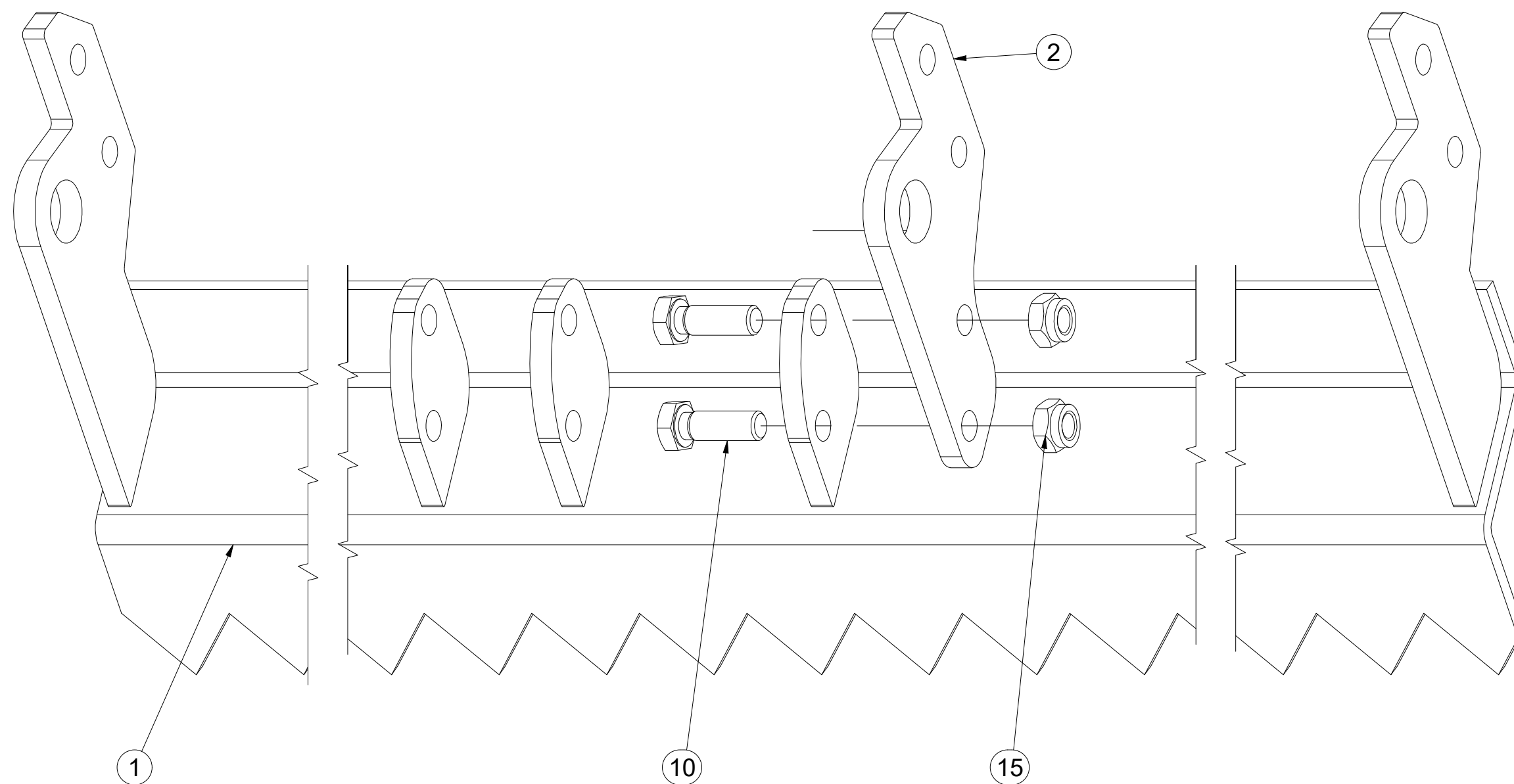

- Ⓒ SADA FINIŠ SMYKŮ
- Ⓓ SATZ FINISH-SCHLEPPE
- Ⓕ KIT DE GUIDES DE FINITION

- Ⓖ SET OF FINISH LEVELLERS
- Ⓡ КОМПЛЕКТ ФИНИШНЫХ БОРОН
- Ⓟ ZESTAW WŁÓK FINISH



VZ00018654

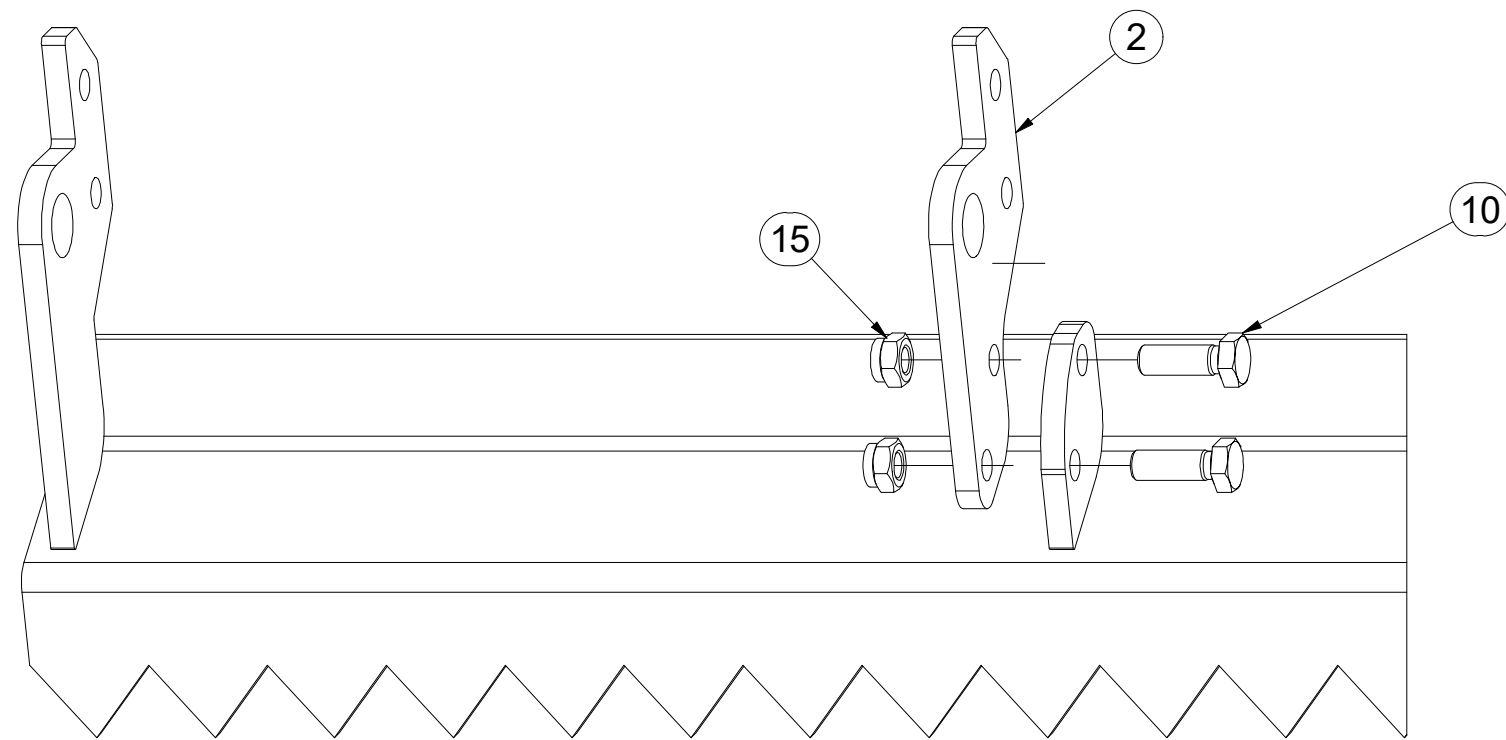
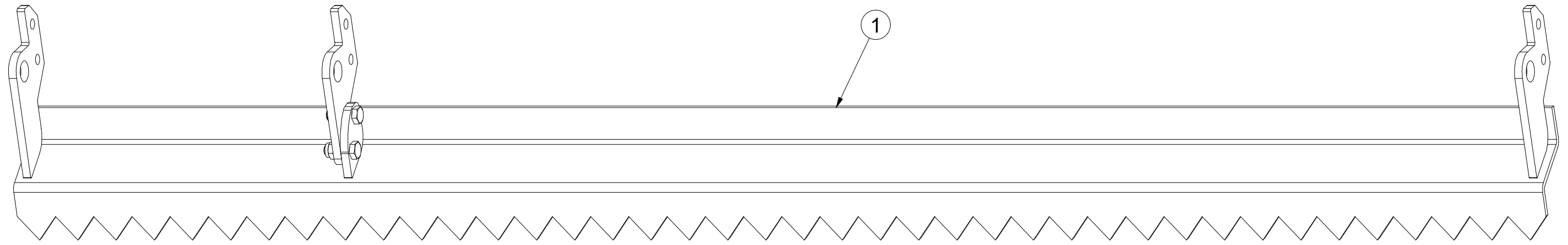

Pos.	Part Number	Pcs.
1	VZ00018653	1
2	VZ00014941	1
10	m04343	2
15	m04301	2

ⒸZ SADA DORAZŮ ZADNÍCH SMYKŮ

Ⓓ ANSCHLAGSATZ FÜR HINTERE ACKERSCHLEPPEN

Ⓕ KIT DE BUTÉES DES NIVELEURS ARRIÈRE

VZ00012931

ⒼB SET OF REAR LEVELLING BAR STOPS

ⒺU КОМПЛЕКТ УПОРОВ ЗАДНИХ БОРОН

ⒽL ZESTAW DOCISKÓW TYLNYCH WŁÓK

Farmet

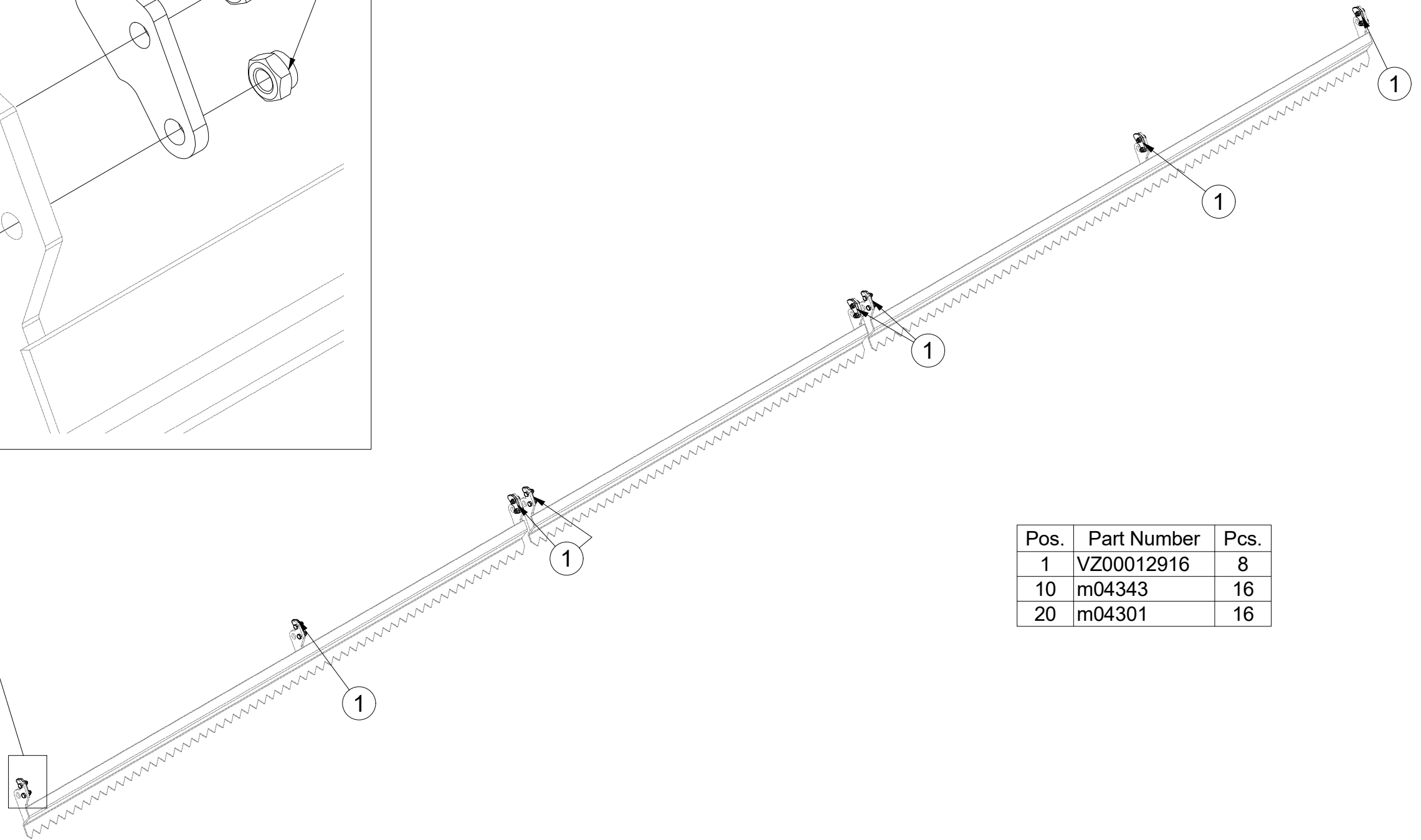
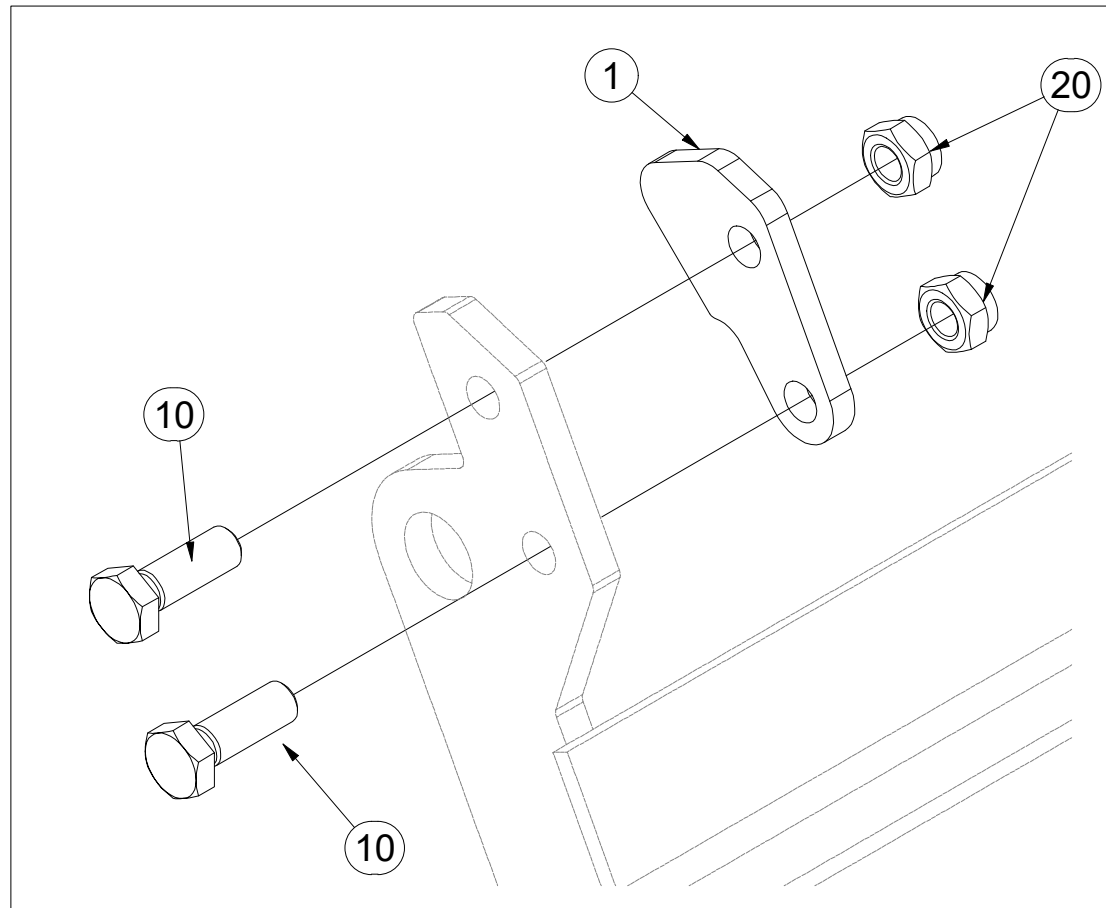

Pos.	Part Number	Pcs.
1	VZ00012916	8
10	m04343	16
20	m04301	16

Ⓒ CZ SADA NÁPRAVY

Ⓓ D SATZ AUFHÄNGUNG

Ⓕ F KIT DE L'ESSIEU

Ⓖ GB AXLE SET

Ⓡ RU КОМПЛЕКТ ОСИ КОЛЁС

Ⓟ PL ZESTAW OSI



3012633

	M18x1,5-265Nm
	400 kPa

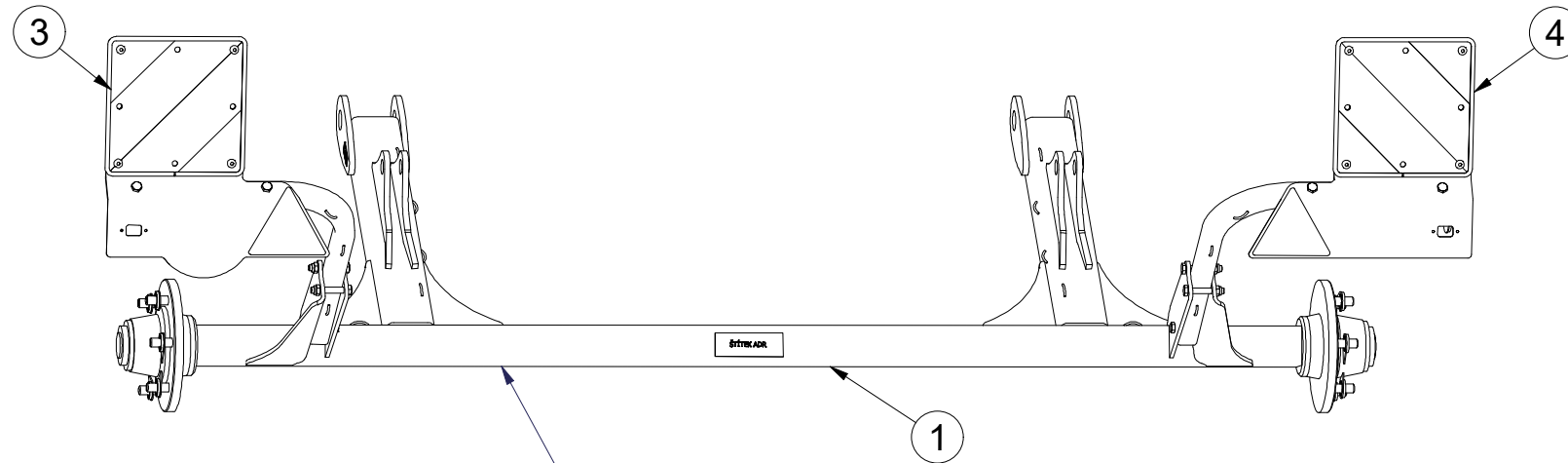

A80RM60

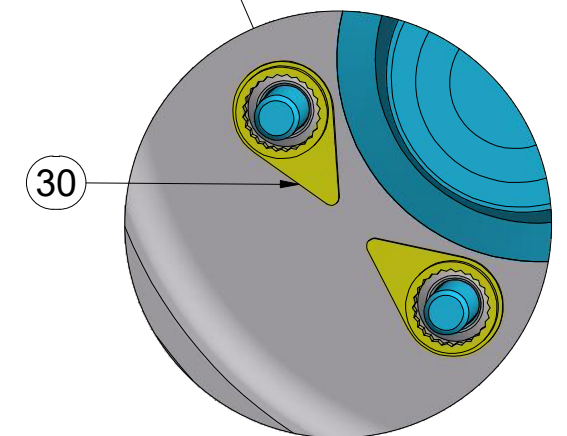
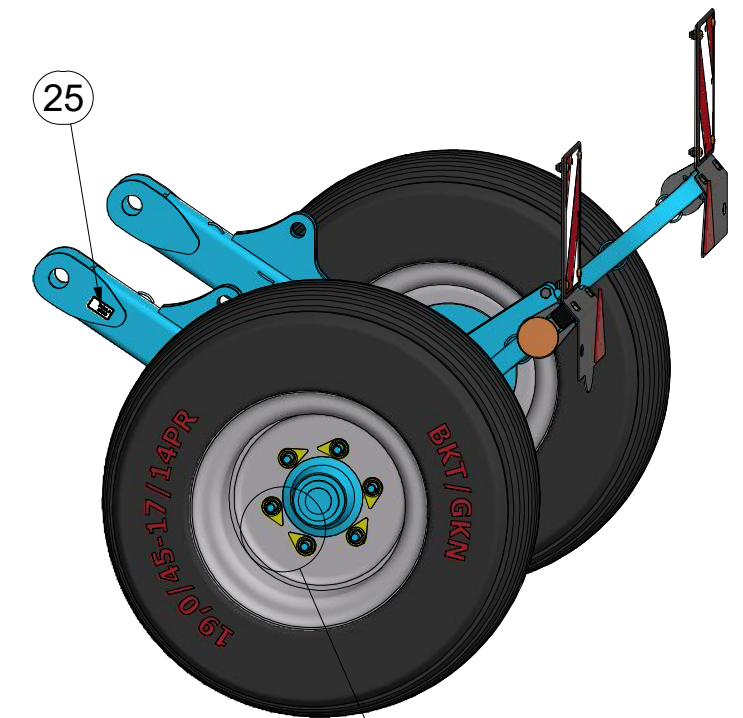
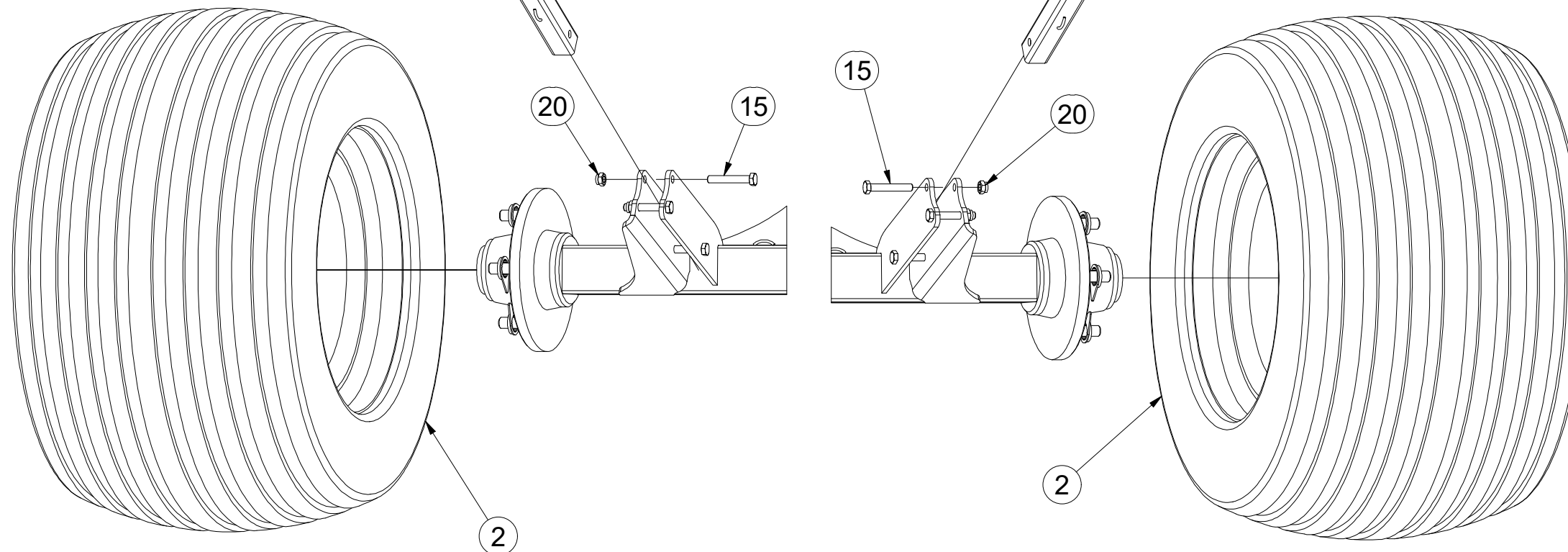

Pos.	Part Number	Pcs.
1	3012632	1
2	m19870	2
3	3012367	1
4	3012389	1
15	m12493	6
20	m04301	6
25	m19732	2
30	m19657	12

Ⓒ NÁPRAVA

Ⓓ ACHSE

Ⓕ ESSIEU

Ⓒ AXLE

Ⓓ OCB

Ⓕ OS



A80RM600

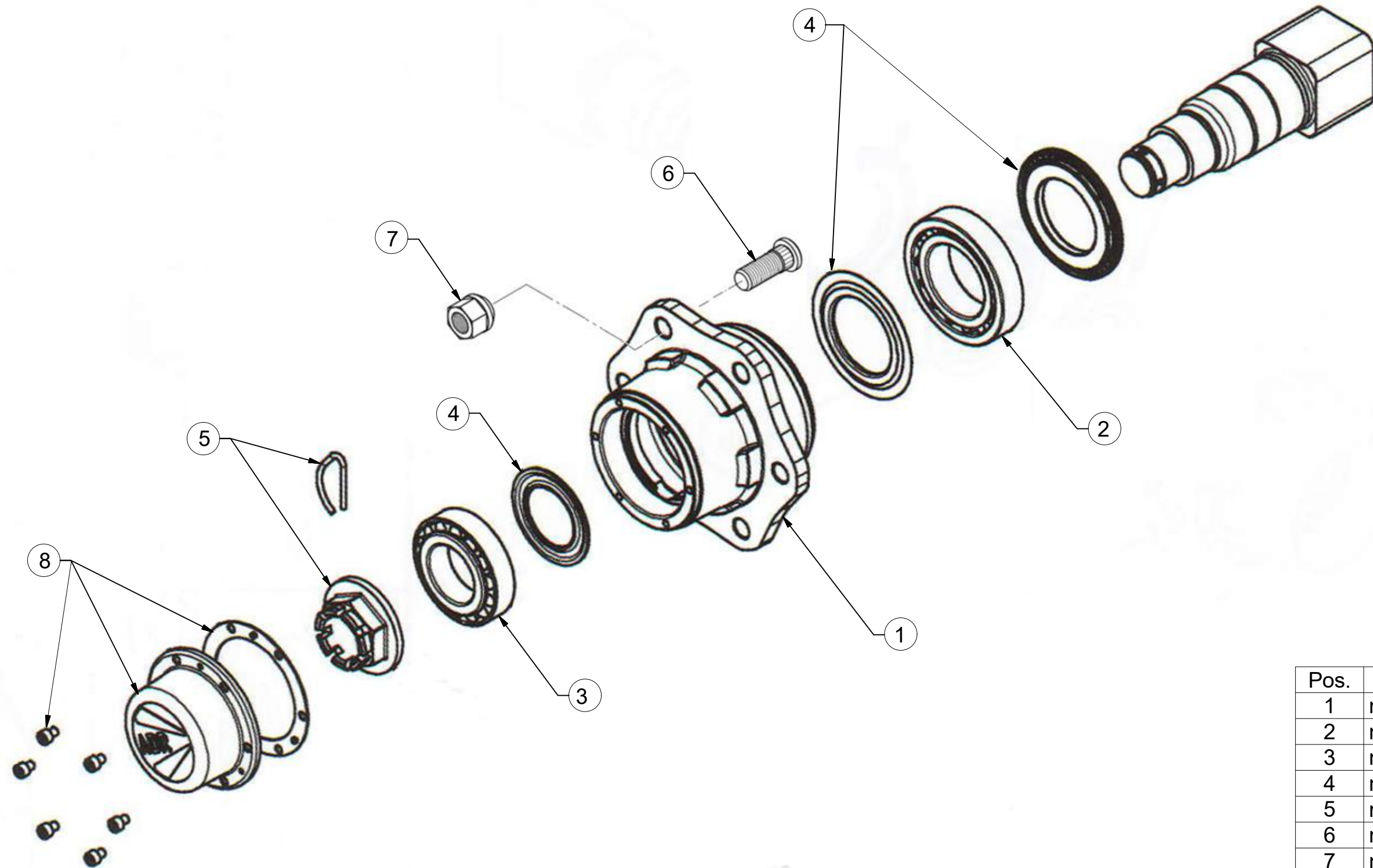

Pos.	Part Number	Pcs.
1	m12567	2
2	m07153	2
3	m07154	2
4	m12565	2
5	m08168	2
6	m08148	12
7	m08163	12
8	m12566	2

ⒸZ TERČ ZADNÍ LEVÝ

Ⓓ SCHILD, HINTERES, LINKES

Ⓕ CIBLE ARRIÈRE GAUCHE

3012367

ⒼB LEFT REAR DISC

ⒺЩИТОК ЗАДНИЙ ЛЕВЫЙ

ⒽL TARCZA TYLNA LEWA

Farmet

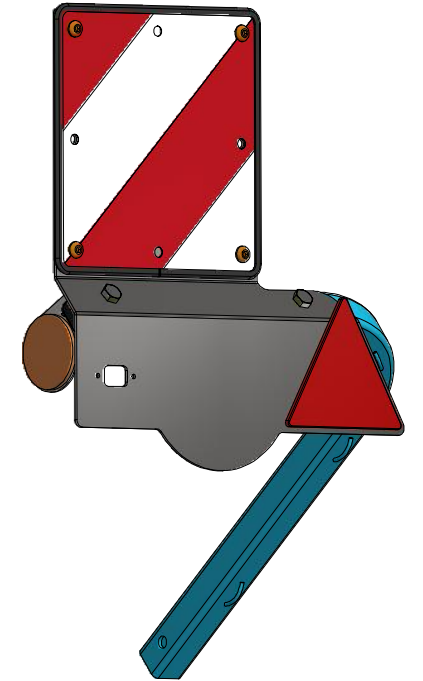
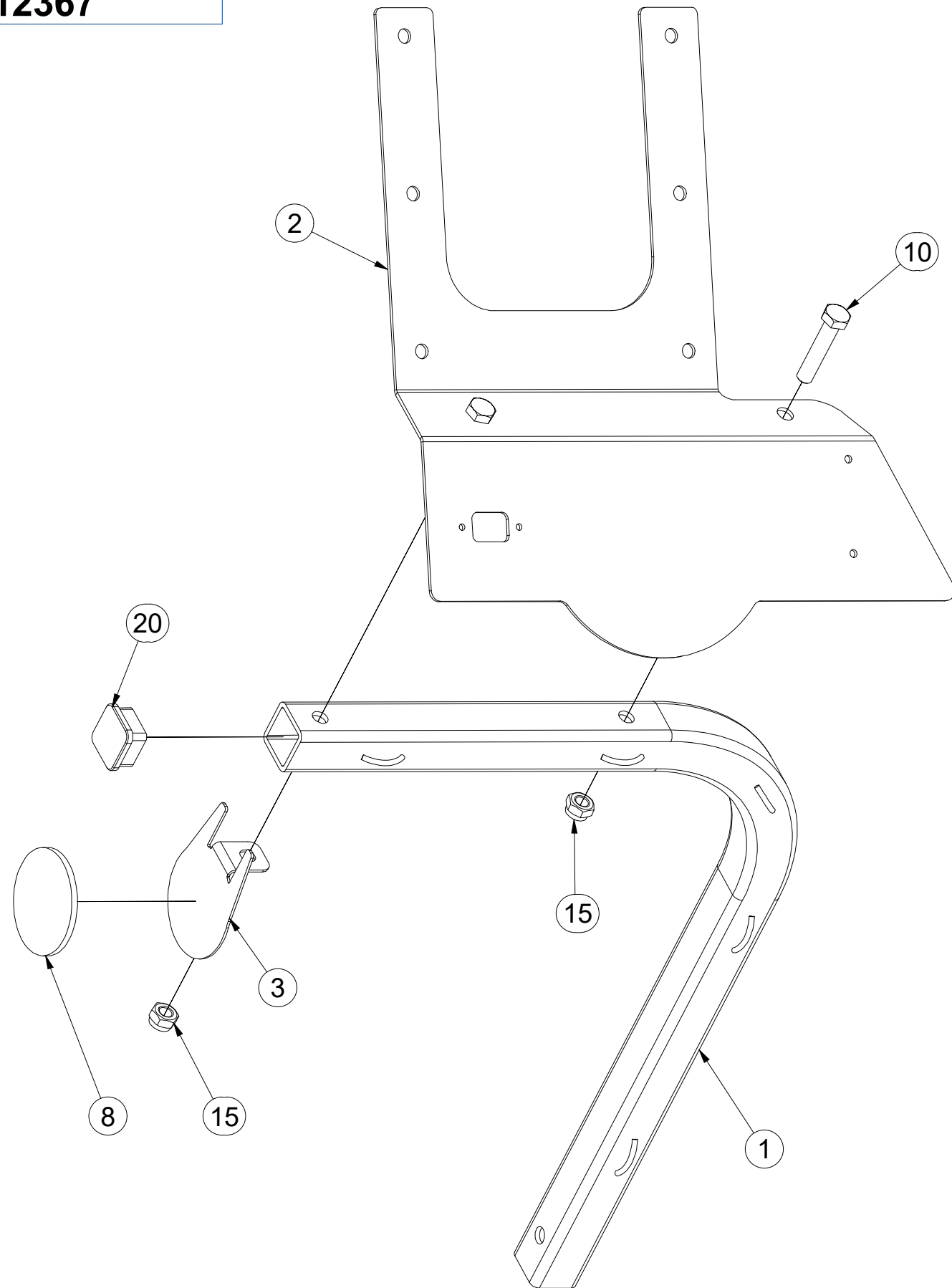

Pos.	Part Number	Pcs.
1	3012364	1
2	3012365	1
3	4024926	1
8	m02579	1
10	m01131	2
15	m04301	2
20	m12689	1

ⒸZ TERČ ZADNÍ LEVÝ

Ⓓ SCHILD, HINTERES, LINKES

Ⓕ CIBLE ARRIÈRE GAUCHE

ⒼB LEFT REAR DISC

ⒶU ЩИТОК ЗАДНИЙ ЛЕВЫЙ

ⒶL TARCZA TYLNA LEWA

Farmet

3012367

Pos.	Part Number	Pcs.
5	m18855	1
6	9005707	1
7	m02497	1
11	m16637	4
16	m03775	4
25	m01209	4

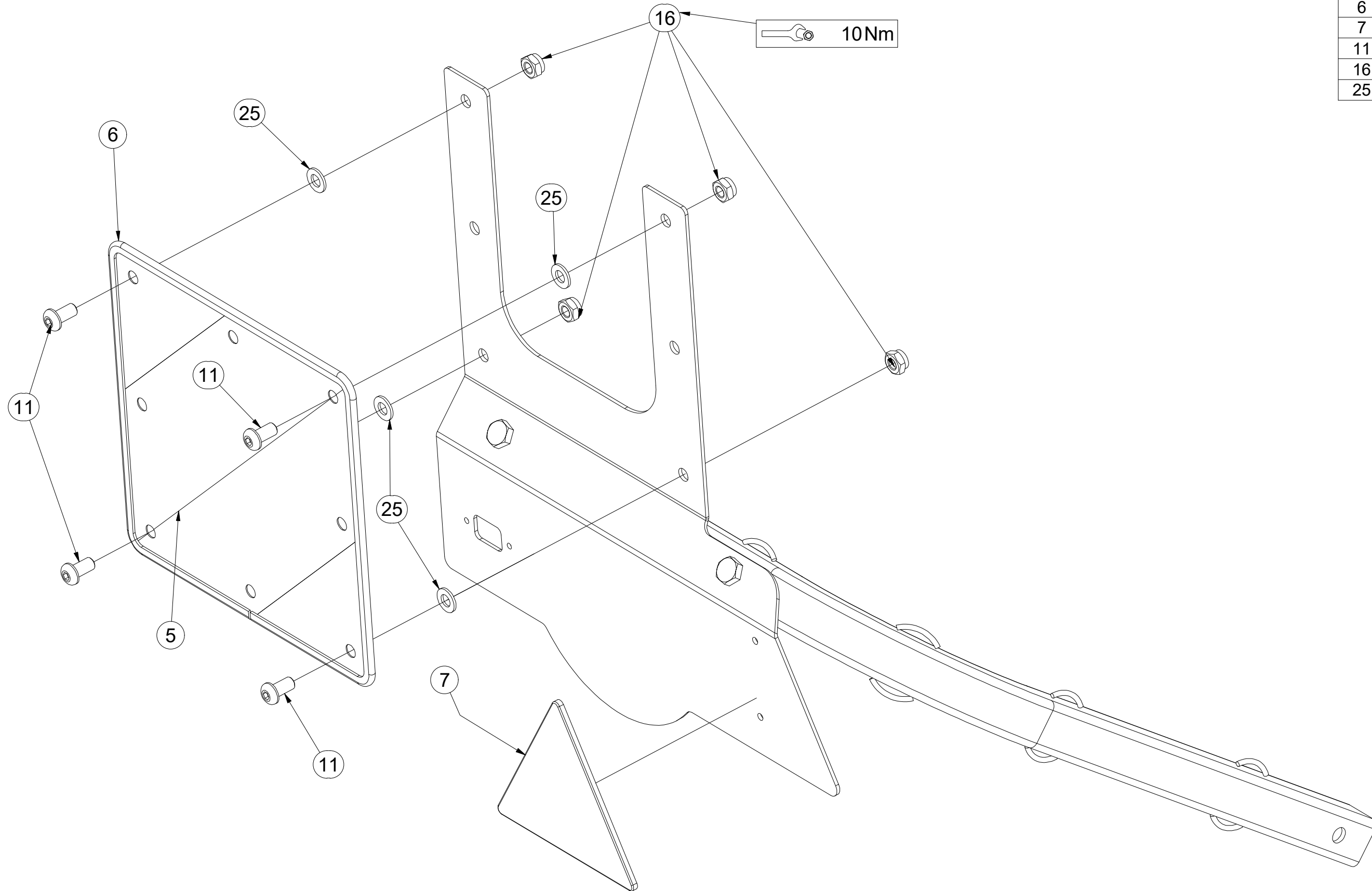

ⒸZ TERČ ZADNÍ PRAVÝ

Ⓓ SCHILD, HINTERES, RECHTES

Ⓕ CIBLE ARRIÈRE DROITE

3012389

ⒼB RIGHT REAR DISC

ⒺU ЩИТОК ЗАДНИЙ ПРАВЫЙ

ⒽL TARCZA TYLNA PRAWA

Farmet

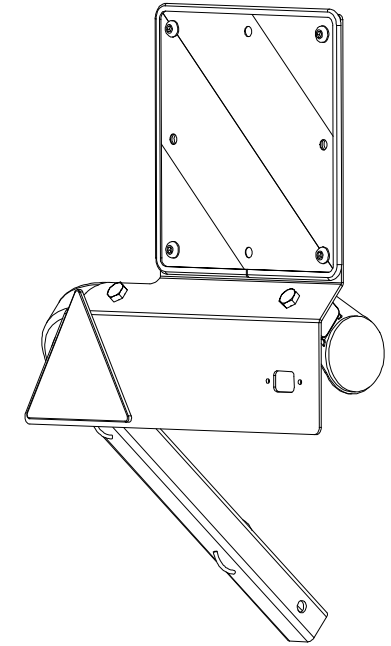
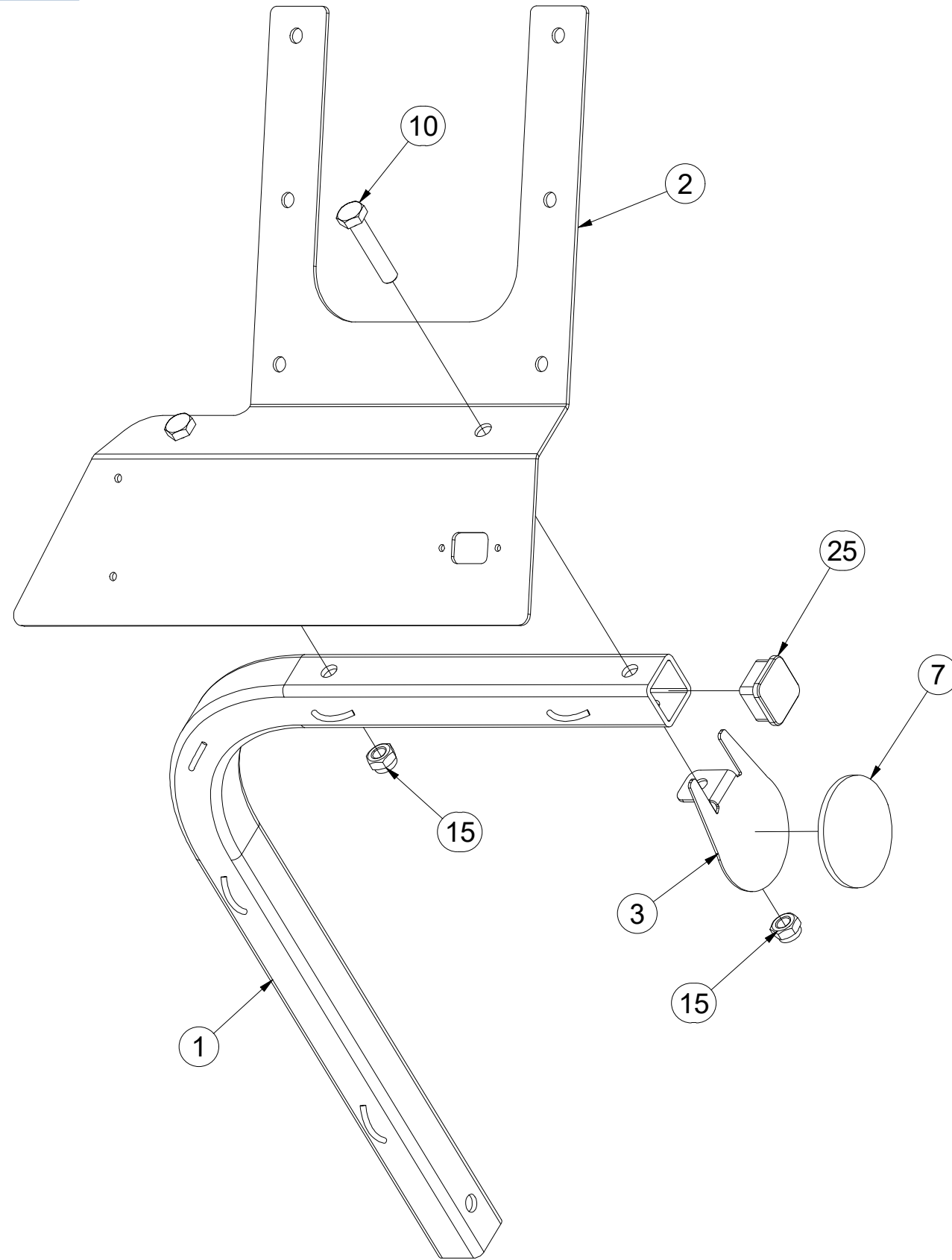

Pos.	Part Number	Pcs.
1	3012364	1
2	3012390	1
3	4024926	1
7	m02579	1
10	m01131	2
15	m04301	2
25	m12689	1

ⒸZ TERČ ZADNÍ PRAVÝ

Ⓓ SCHILD, HINTERES, RECHTES

Ⓕ CIBLE ARRIÈRE DROITE

ⒼB RIGHT REAR DISC

Ⓔ RU ЩИТОК ЗАДНИЙ ПРАВЫЙ

ⒼL TARCZA TYLNA PRAWA

Farmet

3012389

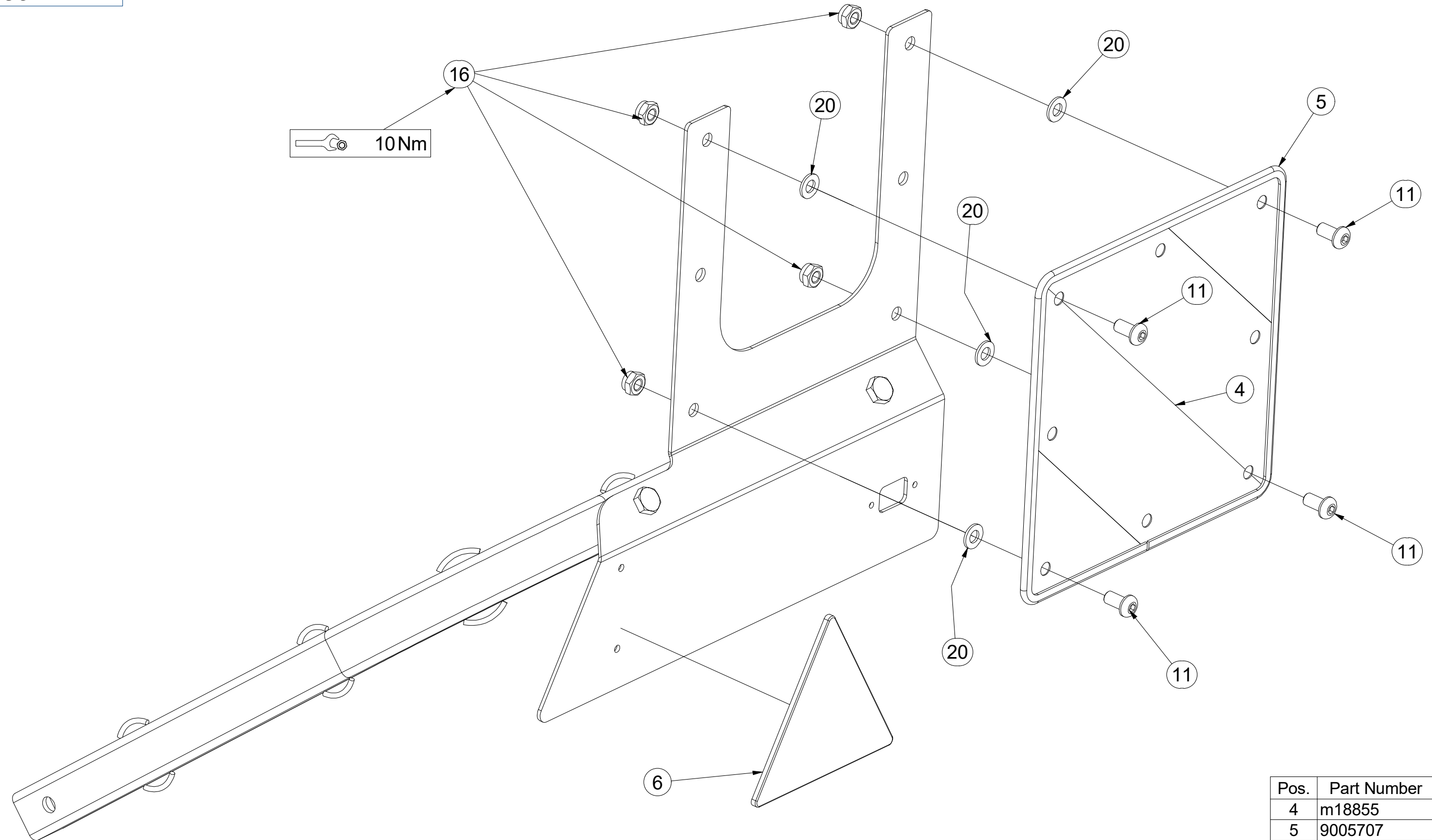

Pos.	Part Number	Pcs.
4	m18855	1
5	9005707	1
6	m02497	1
11	m16637	4
16	m03775	4
20	m01209	4

Ⓒ SAMOLEPKY STROJE

Ⓓ AUFKLEBER MASCHINEN

Ⓕ VOITURE MACHINES

Ⓖ STICKERS MACHINES

Ⓡ СТИКЕРЫ МАШИНЫ

Ⓟ NAKLEJKI MASZYNY



4026236

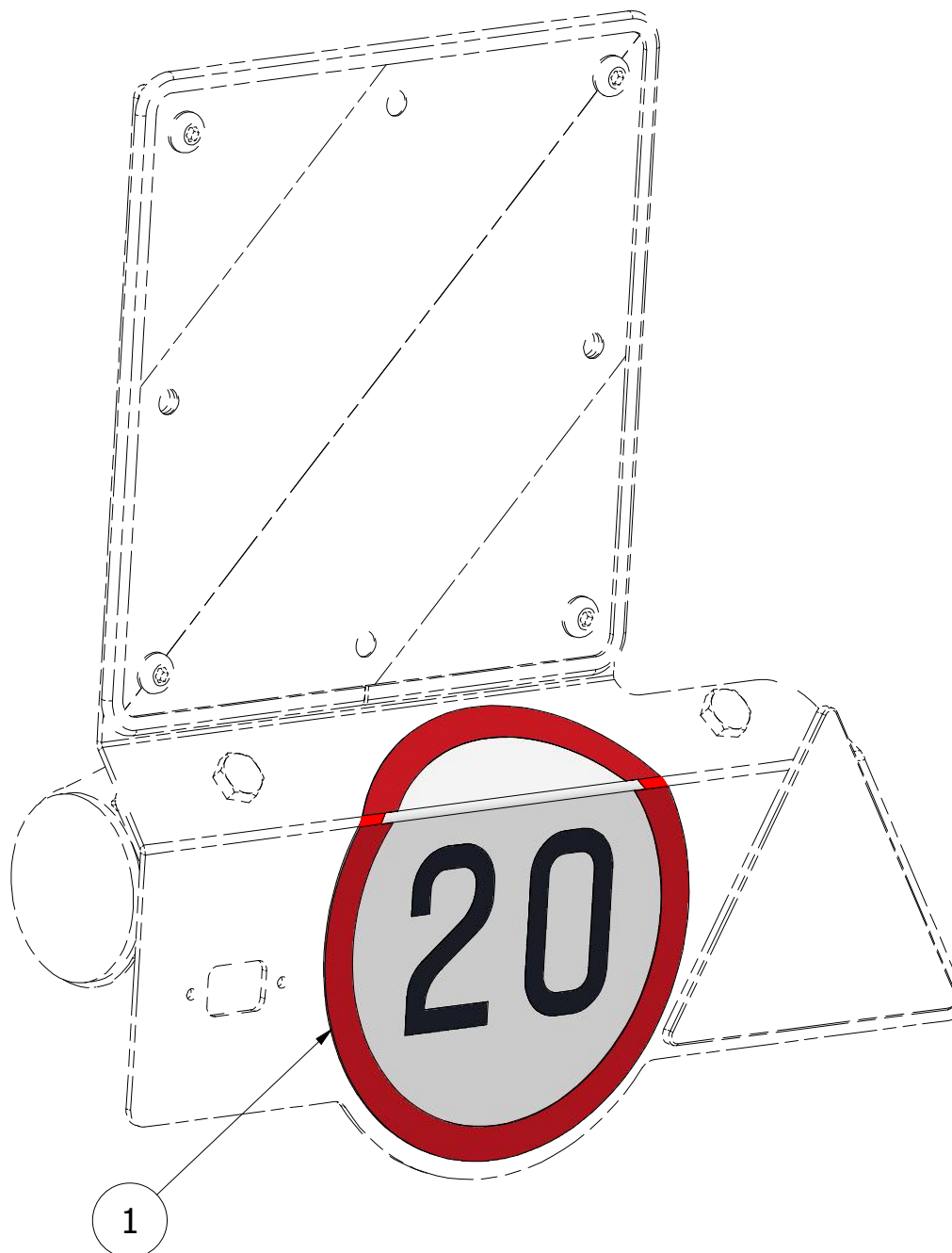

Pos.	Part Number	Pcs.
1	m04406	1

Ⓒ SVĚTELNÁ SADA

Ⓓ LEUCHTENSATZ

Ⓕ KIT LUMINEUX

Ⓖ LIGHTING SET

Ⓡ ОСВЕТИТЕЛЬНЫЙ КОМПЛЕКТ

Ⓟ ZESTAW OŚWIETLENIA



3012429

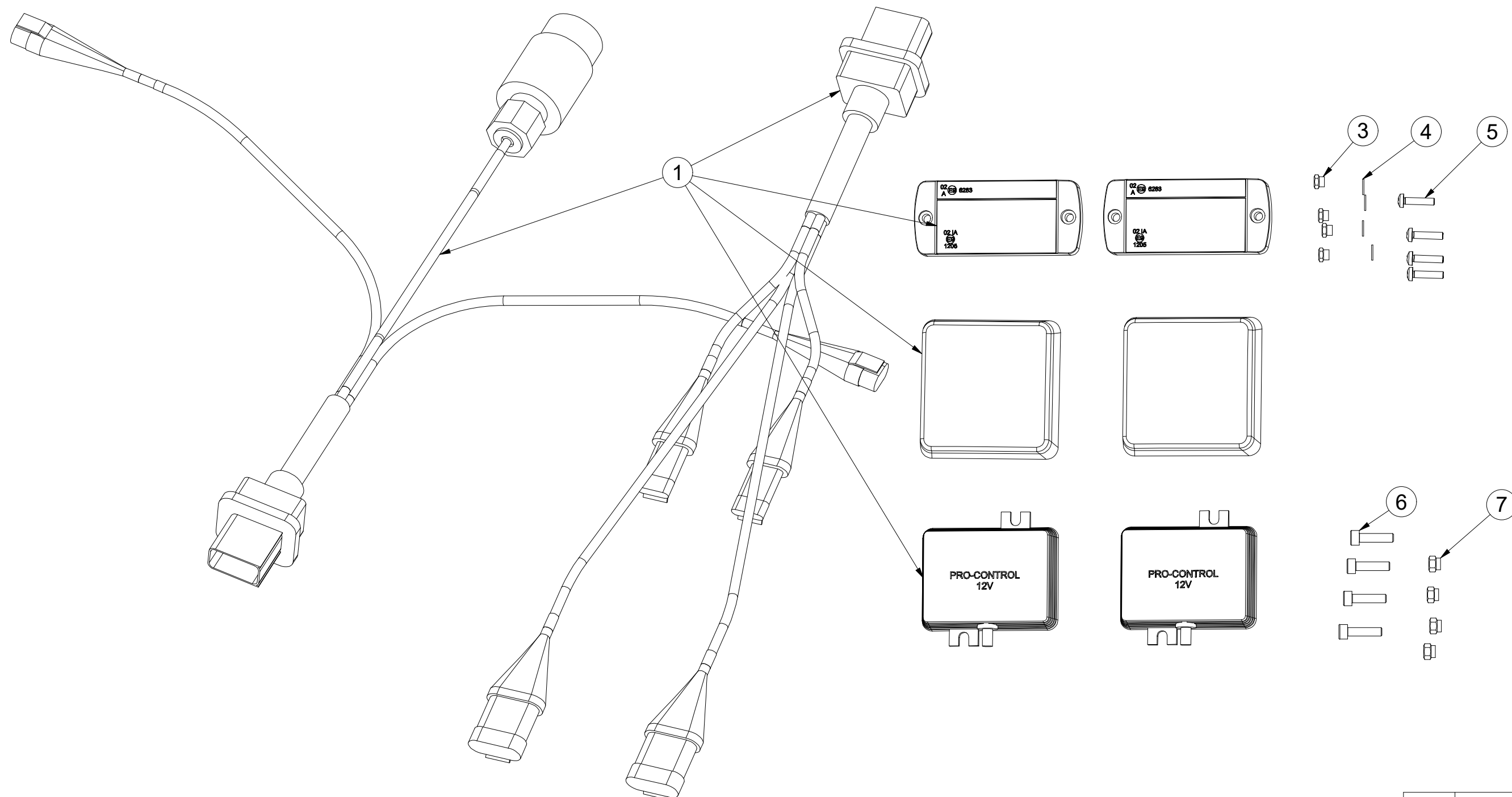

Pos.	Part Number	Pcs.
1	m19043	1
3	m05562	4
4	m05597	4
5	m15790	4
6	m10591	4
7	m06236	4

Ⓒ SVĚTELNÁ SADA

Ⓓ LEUCHTENSATZ

Ⓕ KIT LUMINEUX

Ⓖ LIGHTING SET

Ⓡ ОСВЕТИТЕЛЬНЫЙ КОМПЛЕКТ

Ⓟ ZESTAW OŚWIETLENIA



3012429

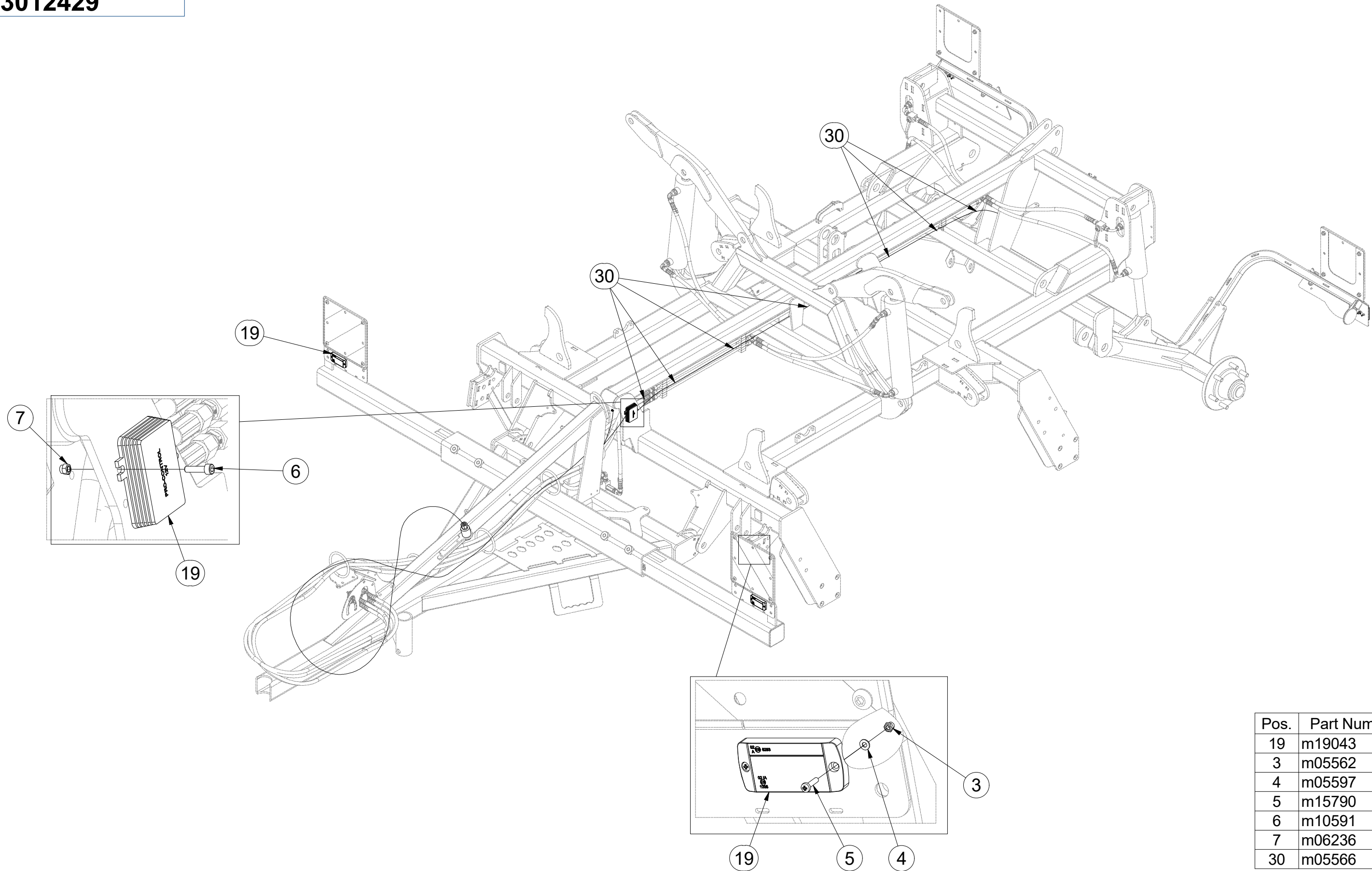

Pos.	Part Number	Pcs.
19	m19043	1
3	m05562	4
4	m05597	4
5	m15790	4
6	m10591	4
7	m06236	4
30	m05566	50

Ⓒ SVĚTELNÁ SADA

Ⓓ LEUCHTENSATZ

Ⓕ KIT LUMINEUX

Ⓖ LIGHTING SET

Ⓡ ОСВЕТИТЕЛЬНЫЙ КОМПЛЕКТ

Ⓟ ZESTAW OŚWIETLENIA

Farmet

3012429

Pos.	Part Number	Pcs.
19	m19043	1
30	m05566	50

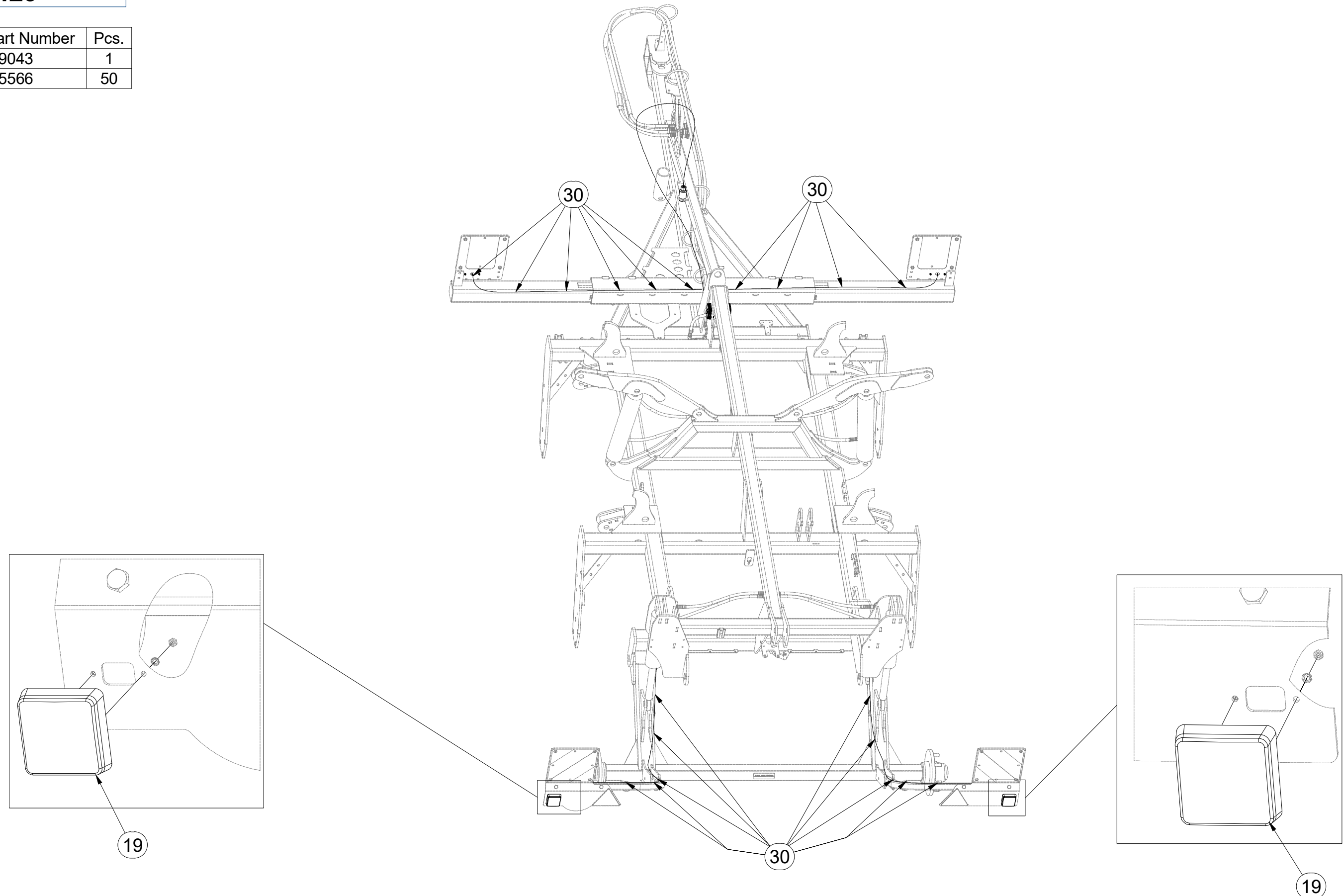

Ⓒ SVĚTELNÁ SADA

Ⓓ LEUCHTENSATZ

Ⓕ KIT LUMINEUX

Ⓖ LIGHTING SET

Ⓡ ОСВЕТИТЕЛЬНЫЙ КОМПЛЕКТ

Ⓟ ZESTAW OŚWIETLENIA



m19043

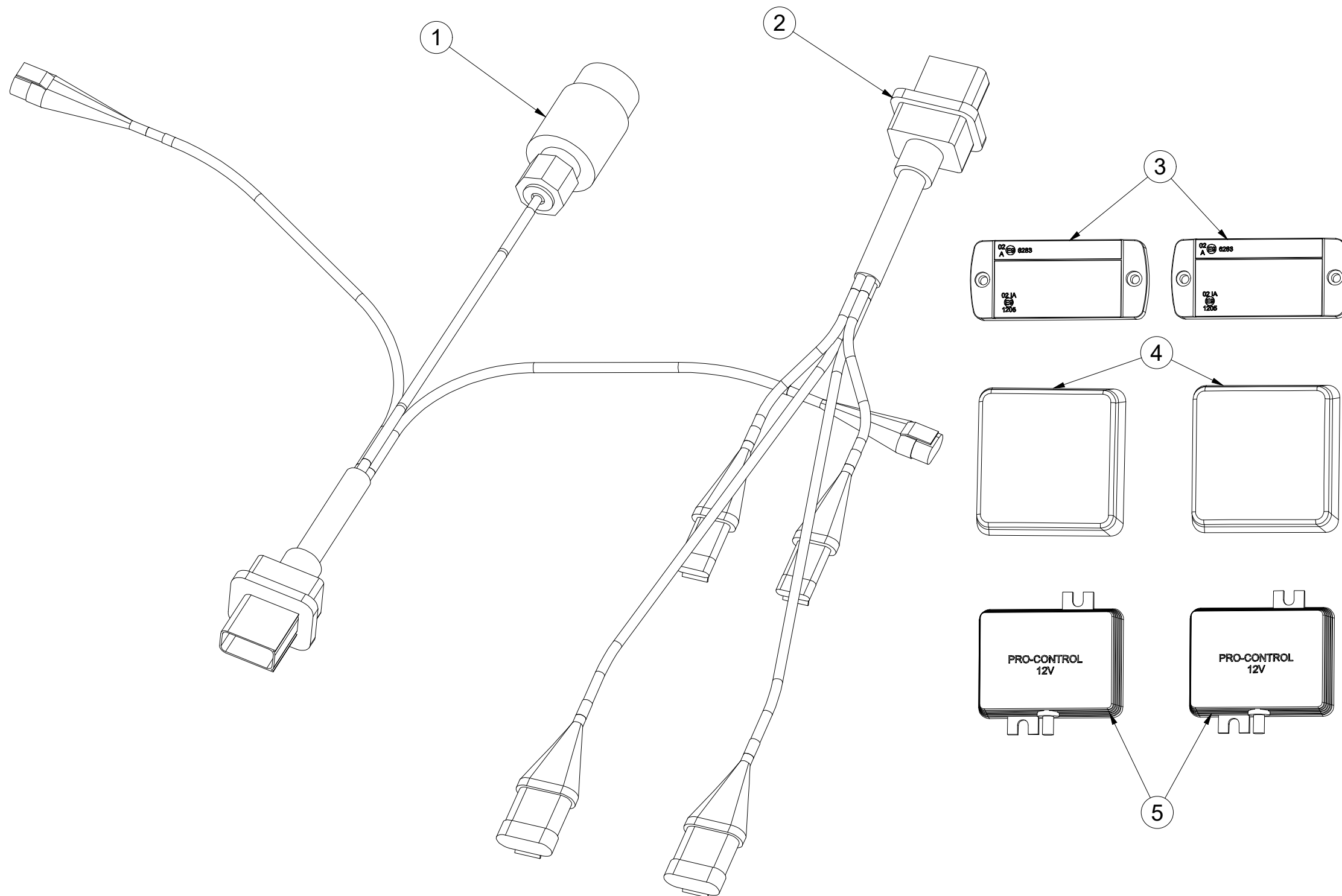

Pos.	Part Number	Pcs.
1	m14779	1
2	m14778	1
3	m14776	2
4	m19044	2
5	m14777	2

Ⓒ SOUPRAVA TĚSNIVA PÍSTNIC

Ⓓ KOLBENSTANGENDICHTUNGSMITTELSATZ

Ⓕ SET DE GARNITURE DES TIGES DE PISTON

Ⓖ SEALING SET FOR PISTON RODS

Ⓡ КОМПЛЕКТ ПРОКЛАДОК ЦИЛИНДРОВ

Ⓟ ZESTAW USZCZELEK TRZPIENIA TŁOKA

Farmet

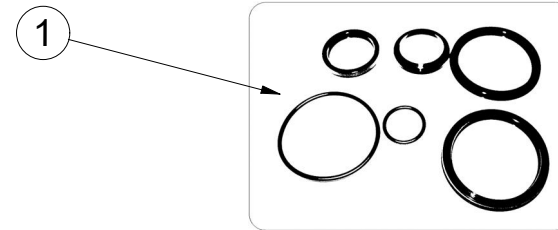
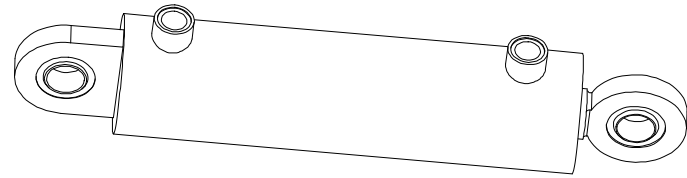

VZ00004549 - $\varnothing 80/\varnothing 40-250$		
Pos	Part number	Pcs
1	m20702	2

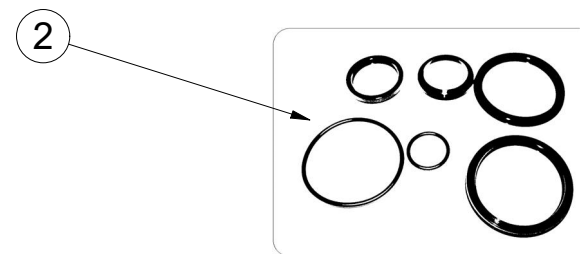
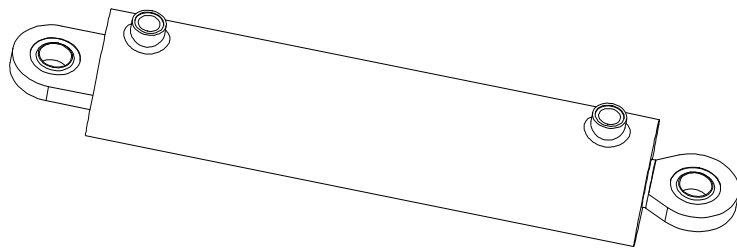

VZ00013004 - $\varnothing 100/\varnothing 45-400$		
Pos	Part number	Pcs
2	m05504	2

- Ⓒ UTAHOVACÍ MOMENTY ŠROUBŮ
 Ⓓ ANZUGMOMENTE VON SCHRAUBEN
 Ⓕ COUPLES DE SERRAGE DES VIS

- Ⓒ SCREW TIGHTENING TORQUE
 Ⓓ МОМЕНТЫ ЗАЖАТИЯ БОЛТОВ
 Ⓕ MOMENTY DOKRĘCANIA ŚRUB



P		5.8	8.8	10.9	12.9	Z	
D	R	Mu	Mu	Mu	Mu	DIN 7991	ISO 10642
mm	mm	Nm	Nm	Nm	Nm	Nm	Nm
M6	1	6	9	13	15	7,2	7,9
M8	1,25	14	22	32	38	17	19
M10	1,5	29	44	64	75	35	38
M12	1,75	49	76	111	130	58	65
M14	2	79	120	176	206	93	100
M16	2	123	188	276	323	144	158
M18	2,5	169	257	378	443	-	220
M20	2,5	239	365	536	628	-	310
M22	2,5	329	529	738	864	-	420
M24	3	413	629	924	1082	-	530
M27	3	613	934	1372	1606	-	-
M30	3,5	832	1267	1862	2179	-	-
M33	3,5	1130	1723	2530	2961	-	-
M36	4	1451	2210	3246	3799	-	-
M39	4	1885	2872	4217	4936	-	-
M42	4,5	2322	3538	5196	6080	-	-
M45	4,5	2909	4433	6511	7619	-	-
M48	5	3513	535	7862	9200	-	-
M52	5	4524	6895	10123	11849	-	-
M56	5,5	5636	8589	12614	14761	-	-

- Mu - Ⓒ UTAHOVACÍ MOMENT
 Ⓓ ANZUGMOMENTE
 Ⓕ COUPLE DE SERRAGE
 Ⓒ TIGHTENING TORQUE
 Ⓓ МОМЕНТ ЗАЖАТИЯ
 Ⓕ MOMENT DOKRĘCANIA
- D - Ⓒ JMENOVITÝ PRŮMĚR
 Ⓓ NENNDURCHMESSER
 Ⓕ DIAMETRE NOMINAL
 Ⓒ NOMINAL DIAMETER
 Ⓓ НОМИНАЛЬНЫЙ ДИАМЕТР
 Ⓕ ŚREDNICA NOMINALNA
- R - Ⓒ ROZTEČ ZÁVITU - STOUPÁNÍ
 Ⓓ GEWINDESTEIGUNG
 Ⓕ PAS DE FILET - PAS
 Ⓒ SCREW PITCH – LEAD
 Ⓓ ШАГ РЕЗЬБЫ
 Ⓕ ROZSTAW GWINTU - SKOKI
- P - Ⓒ PEVNOST
 Ⓓ FESTIGKEIT
 Ⓕ RÉSISTANCE
 Ⓒ STRENGTH
 Ⓓ ПРОЧНОСТЬ
 Ⓕ WYTRZYMA OŚĆ
- Z - Ⓒ ZÁPUSTNÉ ŠROUBY
 Ⓓ SENKKOPFSCHRAUBEN
 Ⓕ VIS A TETE FRAISEE
 Ⓒ COUNTERSUNK SCREWS
 Ⓓ БОЛТЫ С УТОПЛЕННОЙ ГОЛОВКОЙ
 Ⓕ ŚRUBY Z ŁBEM STOŻKOWYM PŁASKIM

- Ⓒ Hodnoty momentů jsou poníženy o -10% oproti tabulkovým hodnotám. Šroubové spoje utahujte dle vyznačeného utahovacího momentu v dokumentaci. Pokud není utahovací moment v dokumentaci vyznačen, utahujte dle obecné tabulky. Pokud je v dokumentaci definován spoj šroubu a matice o různých pevnostech, vždy utahujte na moment komponenty nižší.
- Ⓓ Die Werte der Anzugsmomente sind um 10 % gegenüber den Tabellenwerten verringert. Ziehen Sie die Schraubverbindungen gemäß dem in der Dokumentation festgeschriebenen Anzugsmoment an. Sofern das Anzugsmoment nicht in der Dokumentation aufgeführt ist, ziehen Sie sie gemäß der allgemeinen Tabelle an. Wenn in der Dokumentation eine Verbindung von Schraube und Mutter mit verschiedene Festigkeiten definiert ist, wird immer mit dem Moment des Bauteils mit der geringeren Festigkeit angezogen.
- Ⓕ Les valeurs des couples de serrage sont baissées de 10% par rapport aux valeurs de tableau. Serrez les raccords à vis selon le couple de serrage indiqué dans les documents. Si le couple de serrage n'est pas indiqué dans les documents, serrez selon le tableau général. Si les documents définissent un assemblage par boulon de diverses résistances, serrez toujours au moment de la composante avec résistance inférieure.
- Ⓒ The torque values are reduced by 10% compared to the table values. Tighten the screw joints according to the tightening torque stated in the documentation. If the tightening torque is not stated in the documentation, tighten according to the general table. If there is a joint with a screw and a nut at different strengths in the documentation, always tighten to the torque of the component with lower strength.
- Ⓓ Значения моментов затяжки уменьшены на 10% по сравнению с данными в таблице. Резьбовые соединения зажимайте с установленным в документации моментом зажатия. Если в документации не указан момент зажатия, то зажимайте по действующей в общем таблице. Если в документации установлено соединение из болта и гайки различной прочности, всегда зажимайте с моментом для компонента с меньшей прочностью.
- Ⓕ Wartości momentów dokręcania są obniżone o 10% w stosunku do wartości z tabeli. Połączenia śrubowe należy dokręcać zgodnie z momentem obrotowym w dokumentacji. Jeśli w dokumentacji nie ma podanego momentu obrotowego, należy dokręcać zgodnie z ogólną tabelą. Jeśli w dokumentacji zdefiniowane jest połączenie ze śrubą nakrętką różnych wytrzymałościach, zawsze należy dokręcać zachowując moment dokręcania komponentu z niższą wytrzymałością.

- Ⓒ UTAHOVACÍ MOMENTY ŠROUBŮ
 Ⓓ ANZUGMOMENTE VON SCHRAUBEN
 Ⓕ COUPLES DE SERRAGE DES VIS

- Ⓒ SCREW TIGHTENING TORQUE
 Ⓓ MOMENTY ZAJATIA BOLTOB
 Ⓕ MOMENTY DOKRĘCANIA ŚRUB



- Ⓒ **OBECNÝ PŘEDPIS UTAHOVÁNÍ ZAJIŠTĚNÍ ČEPOVÝCH SPOJŮ:**
 Ⓓ **ALLGEMEINE VORSCHRIFT FÜR DAS ANZIEHEN VON BOLZENVERBINDUNGEN:**
 Ⓕ **CONSIGNE GENERALE POUR LE SERRAGE DES ARTICULATIONS CYLINDRIQUES:**
 Ⓒ **GENERAL INSTRUCTION FOR TIGHTENING THE SECURING OF PIN JOINTS:**
 Ⓓ **ОБЩЕЕ ОПИСАНИЕ ЗАЖАТИЯ ПРЕДОХРАНЕНИЯ СОЕДИНЕНИЙ ПАЛЬЦАМИ:**
 Ⓕ **OGÓLNE ZASADY DOKRĘCANIA ZABEZPIECZENIA POŁĄCZEŃ CZOPEM:**



X

M8, M10, M12

M14

M

09-15Nm

15-25Nm

- X - Ⓒ ROZMĚR ŠROUBU
 Ⓓ SCHRAUBENGRÖSSE
 Ⓕ DIMENSIONS DE LA VIS

- Ⓒ BOLT DIMENSION
 Ⓓ РАЗМЕР БОЛТА
 Ⓕ ROZMIAR ŚRUBY

- M - Ⓒ ORIENTAČNÍ MOMENT
 Ⓓ ANZUGSMOMENT
 Ⓕ COUPLE D'ORIENTATION

- Ⓒ ORIENTATION TORQUE
 Ⓓ ОРИЕНТАЦИОННЫЙ МОМЕНТ
 Ⓕ ORIENTACYJNY MOMENT

- Ⓒ Tyto spoje není nutné ověřovat kontrolou momentovým klíčem = stačí vizuálně kontrolovat sešroubování.
 Ⓓ Diese Verbindungen müssen nicht mit einem Drehmomentschlüssel überprüft werden = es genügt, die Verschraubung visuell zu kontrollieren.
 Ⓕ Il n'est pas nécessaire de contrôler le serrage à l'aide d'une clé dynamométrique = un contrôle visuel de l'assemblage suffit.
 Ⓒ These joints do not have to be verified by checking with a torque wrench = visual inspection of bolting is sufficient.
 Ⓓ Эти соединения не нужно контролировать динамометрическим ключом = достаточно визуально проверять прикручивание.
 Ⓕ Nie trzeba sprawdzać tych połączeń kluczem dynamometrycznym = wystarczy wizualnie skontrolować dokręcenie.