

The effective technology

Farmet[®]

ⒸZ KATALOG NÁHRADNÍCH DÍLŮ ⒸB CATALOGUE OF SPARE PARTS ⒸD ERSATZTEILLISTE
ⒸRU КАТАЛОГ ЗАПАСНЫХ ЧАСТЕЙ ⒸF CATALOGUE DES PIÈCES DE RECHANGE ⒸPL KATALOG CZĘŚCI ZAMIENNYCH

KOMPAKTOMAT K500PS

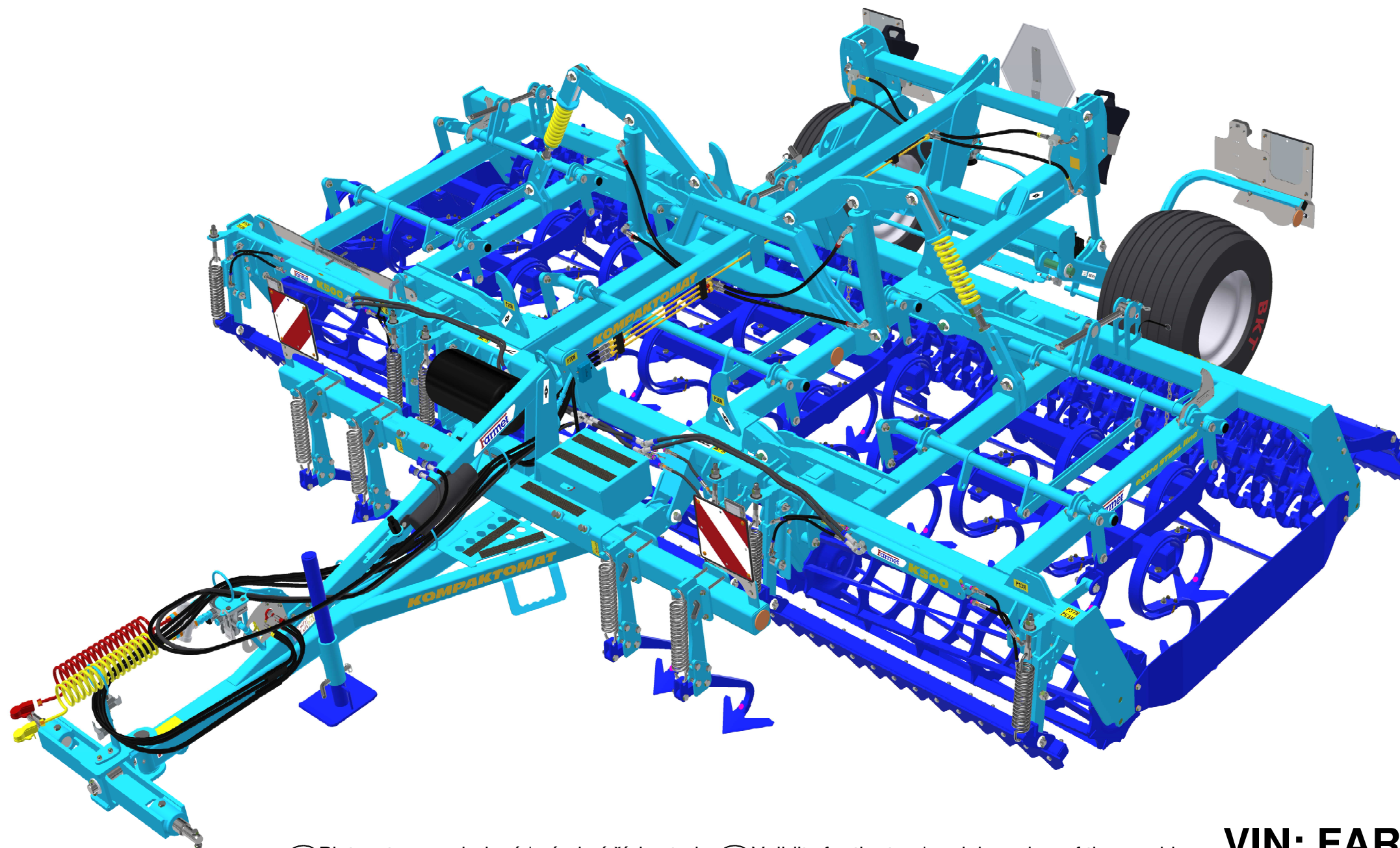

ⒸZ Platnost pro vrcholové | výrobní číslo stroje ⒸB Validity for the top | serial number of the machine
ⒸD Gültigkeit für die Haupt- | Herstellungsnummer der Maschine ⒸRU Действительно для главного | заводского номера машины
ⒸF Validité du numéro de référence | de série de la machine ⒸPL Obowiązuje dla numeru głównego | seryjnego maszyny

VIN: FAR12036CN0000750
9333697 | 2022/0750

Farmet a. s.
Jiřinková 276
552 03 Česká Skalice, CZ

telefon: +420 491 450 111
fax: +420 491 450 136
GSM: +420 774 715 738

IČ: 46504931
DIČ: CZ46504931

web: www.farmet.cz
e-mail: farmet@farmet.cz

ⒸZ NAVIGACE STROJE

Ⓓ NAVIGATION DER MASCHINE

Ⓕ NAVIGATION DE LA MACHINE

ⒸB NAVIGATION OF THE MACHINE

ⒸU НАВИГАЦИЯ МАШИНЫ

ⒸL NAWIGACJA MASZYNY

Farmet

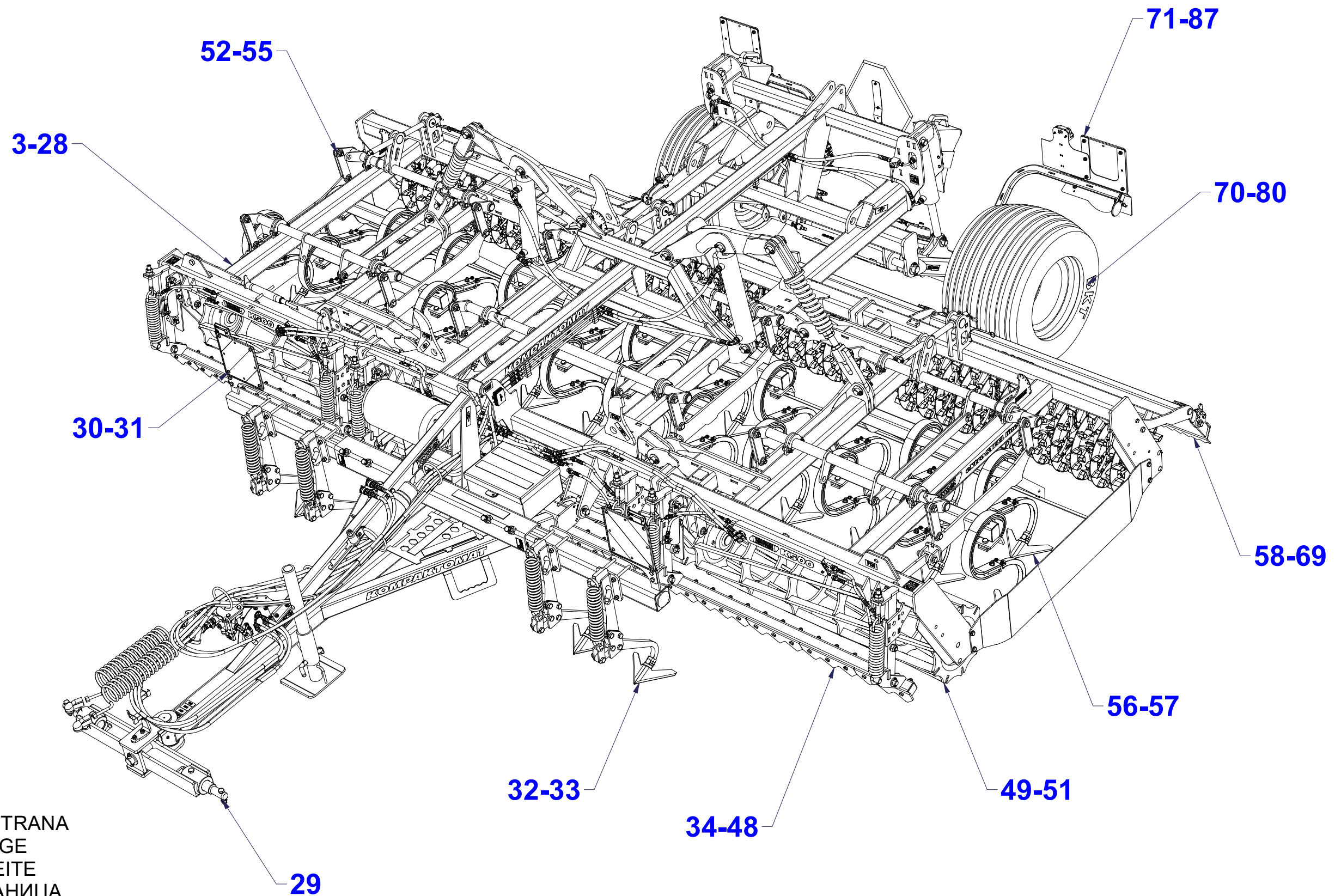

ⒸZ NÁHRADNÍ DÍL - STRANA

ⒸB SPARE PART - PAGE

Ⓓ ERSATZTEILE - SEITE

ⒸU ЗАПЧАСТЬ - СТРАНИЦА

Ⓕ PIÈCE DE RECHANGE - PAGE

ⒸL CZĘŚCI ZAMIENNE - STRONA

☉ POLOTOVAR STROJE

☉ MASCHINEN-HALBFABRIKAT

☉ MACHINE - SEMI-PRODUIT

☉ SEMIFINISHED MACHINE

☉ ПОЛУФАБРИКАТ МАШИНЫ

☉ PÓLFABRYKAT MASZYNY



VZ00018649

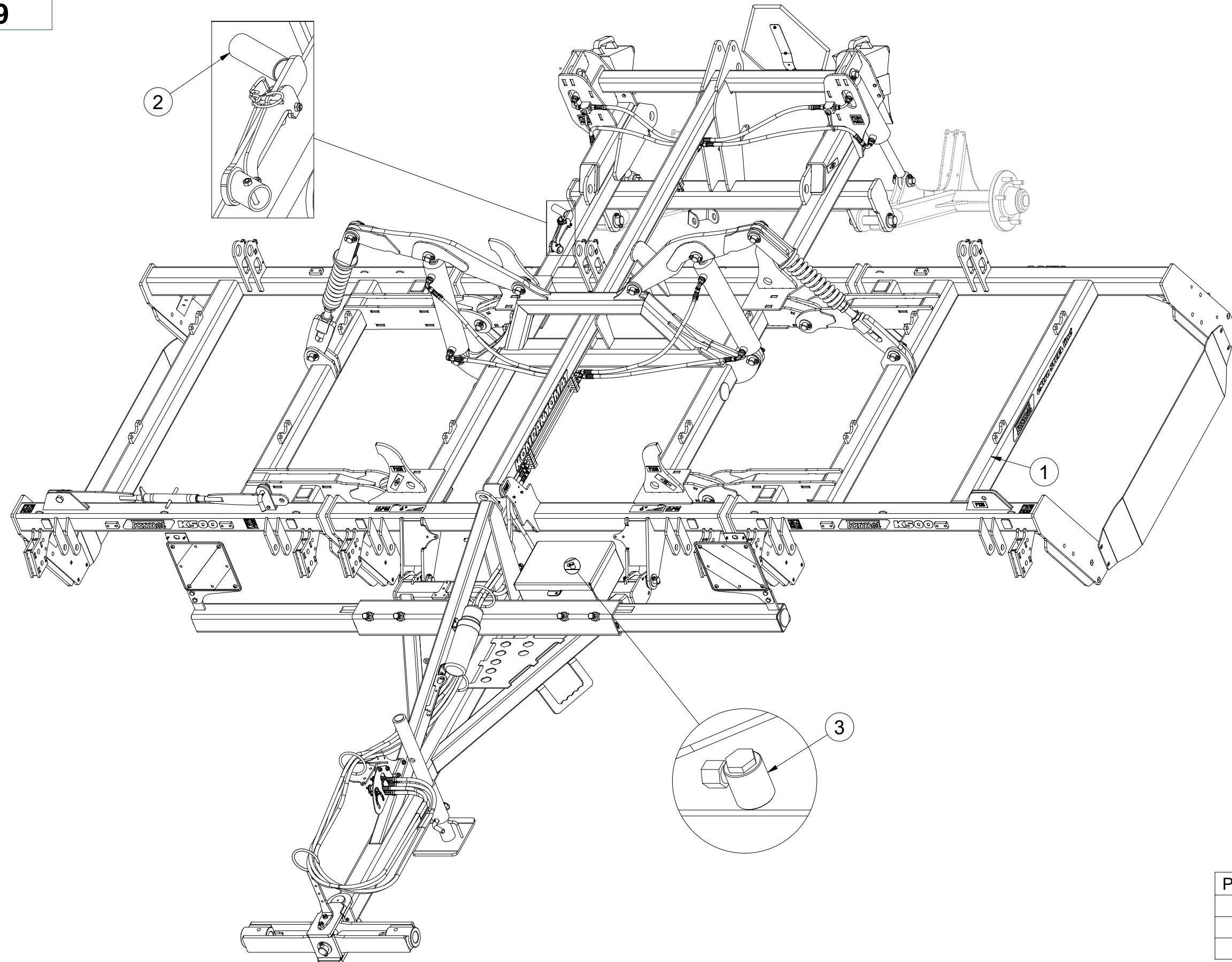

| Pos. | Part Number | Pcs. |
|------|-------------|------|
| 1 | 3012505 | 1 |
| 2 | 4003087 | 1 |
| 3 | 9002395 | 1 |

Ⓒ NASAZOVACÍ KLIKA

Ⓓ MONTAGEGRIF

Ⓕ POIGNÉE DE MONTAGE

4003087

Ⓖ MOUNTING HANDLE

Ⓡ МОНТАЖНАЯ РУЧКА

Ⓟ UCHWYT MONTAŻOWY

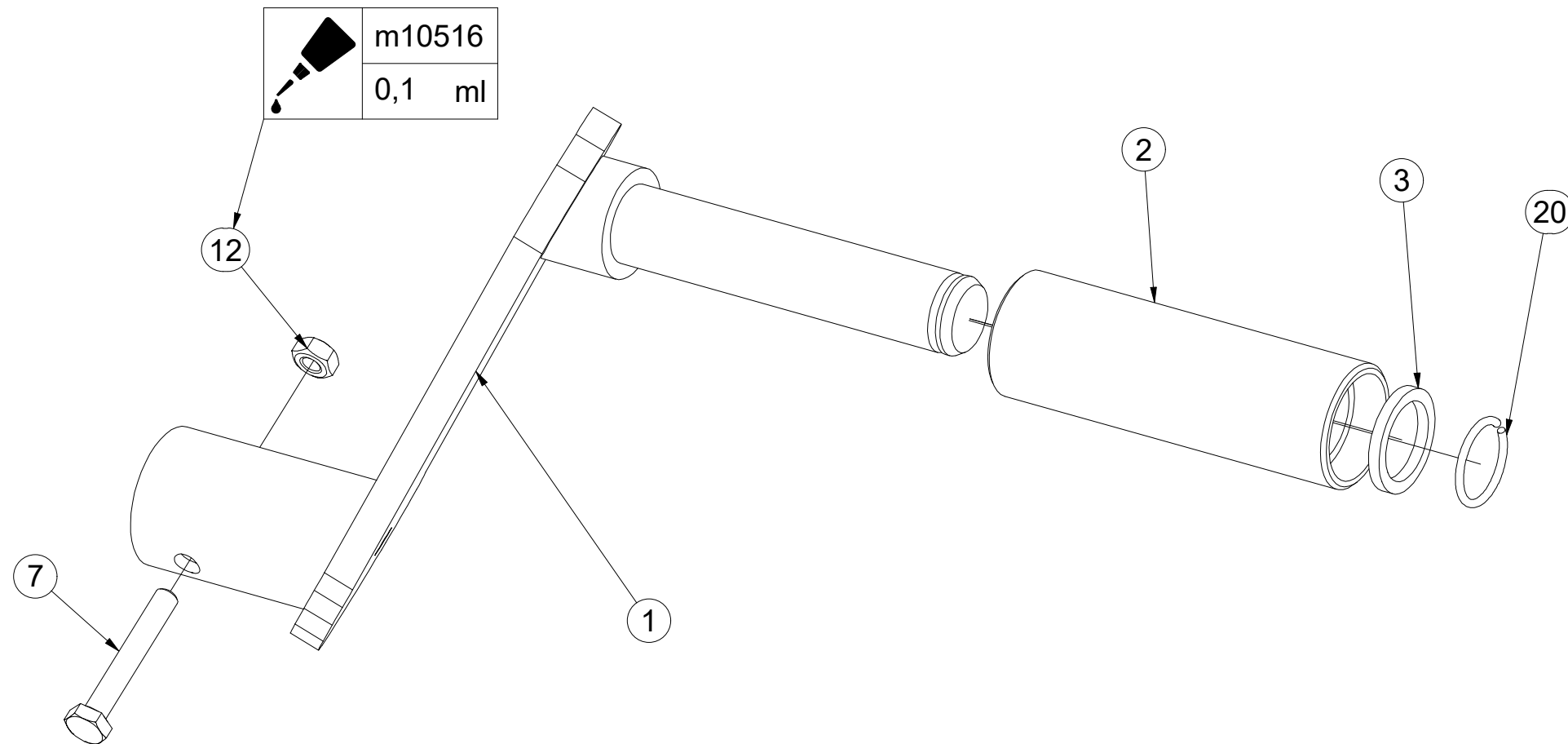
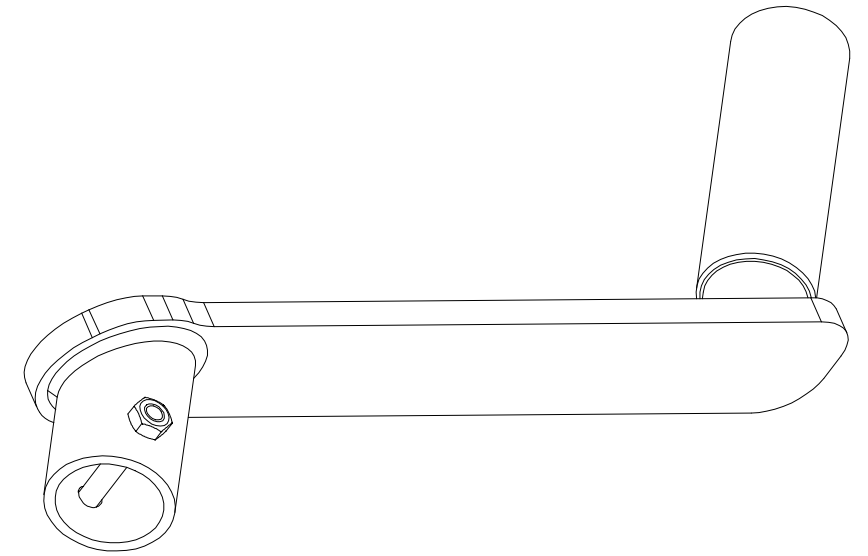

| Pos. | Part Number | Pcs. |
|------|-------------|------|
| 1 | 4003092 | 1 |
| 2 | 4001533 | 1 |
| 3 | 4004828 | 1 |
| 7 | m04641 | 1 |
| 12 | m01295 | 1 |
| 20 | m06561 | 1 |
| 25 | m10516 | 0,1 |

☉ POLOTOVAR STROJE

☉ MASCHINEN-HALBFABRIKAT

☉ MACHINE - SEMI-PRODUIT

☉ SEMIFINISHED MACHINE

☉ ПОЛУФАБРИКАТ МАШИНЫ

☉ PÓLFABRYKAT MASZYNY



3012505

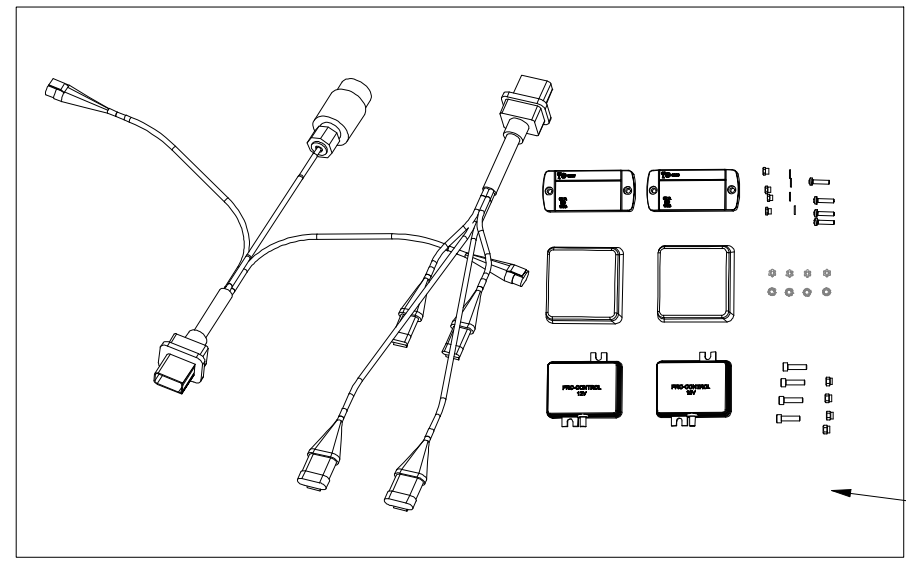
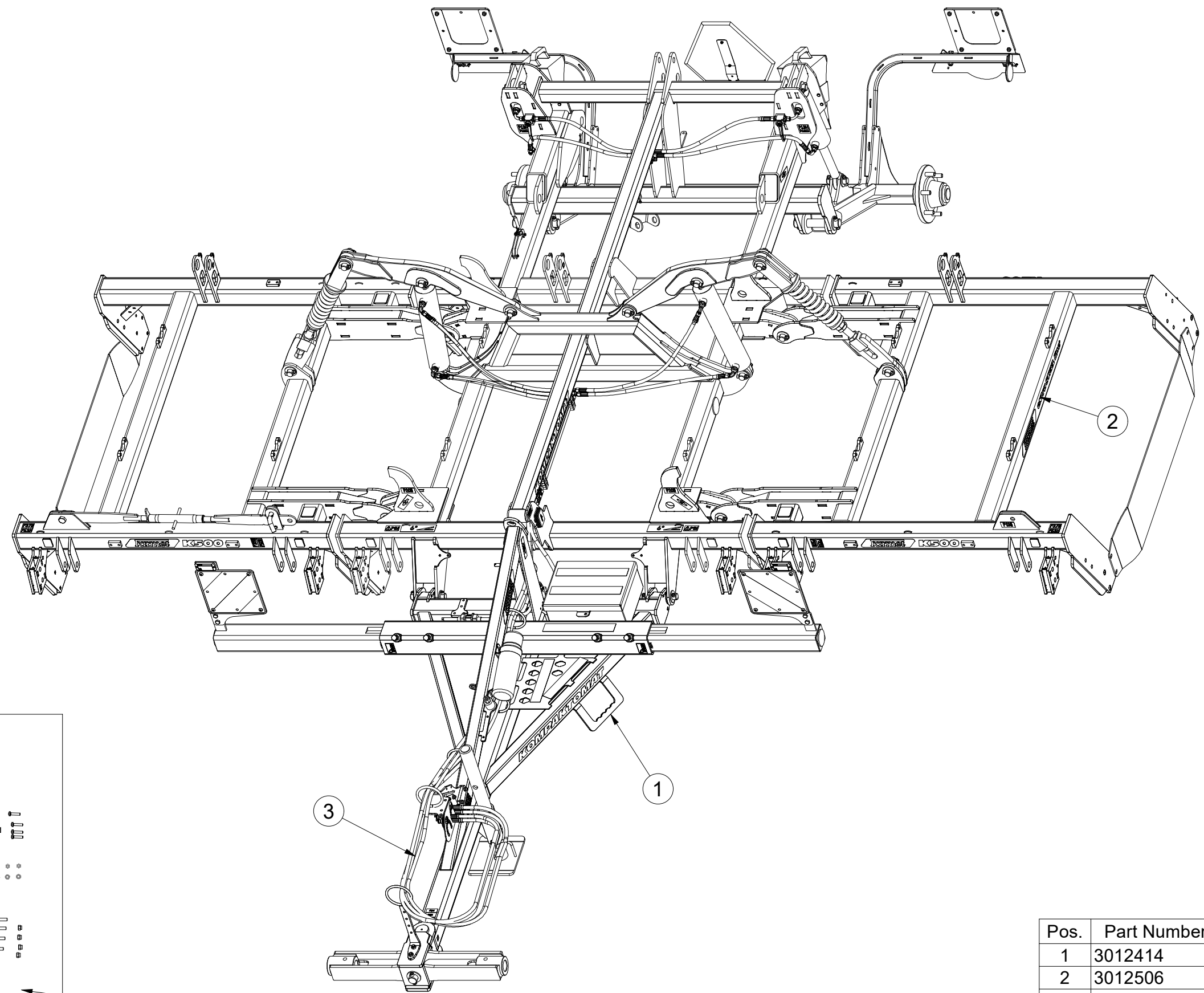

| Pos. | Part Number | Pcs. |
|------|-------------|------|
| 1 | 3012414 | 1 |
| 2 | 3012506 | 1 |
| 3 | 3011328 | 1 |
| 4 | 3012429 | 1 |

☉ POLOTOVAR STROJE

☉ MASCHINEN-HALBFABRIKAT

☉ MACHINE - SEMI-PRODUIT

☉ SEMIFINISHED MACHINE

☉ ПОЛУФАБРИКАТ МАШИНЫ

☉ PÓLFABRYKAT MASZYNY



3012505

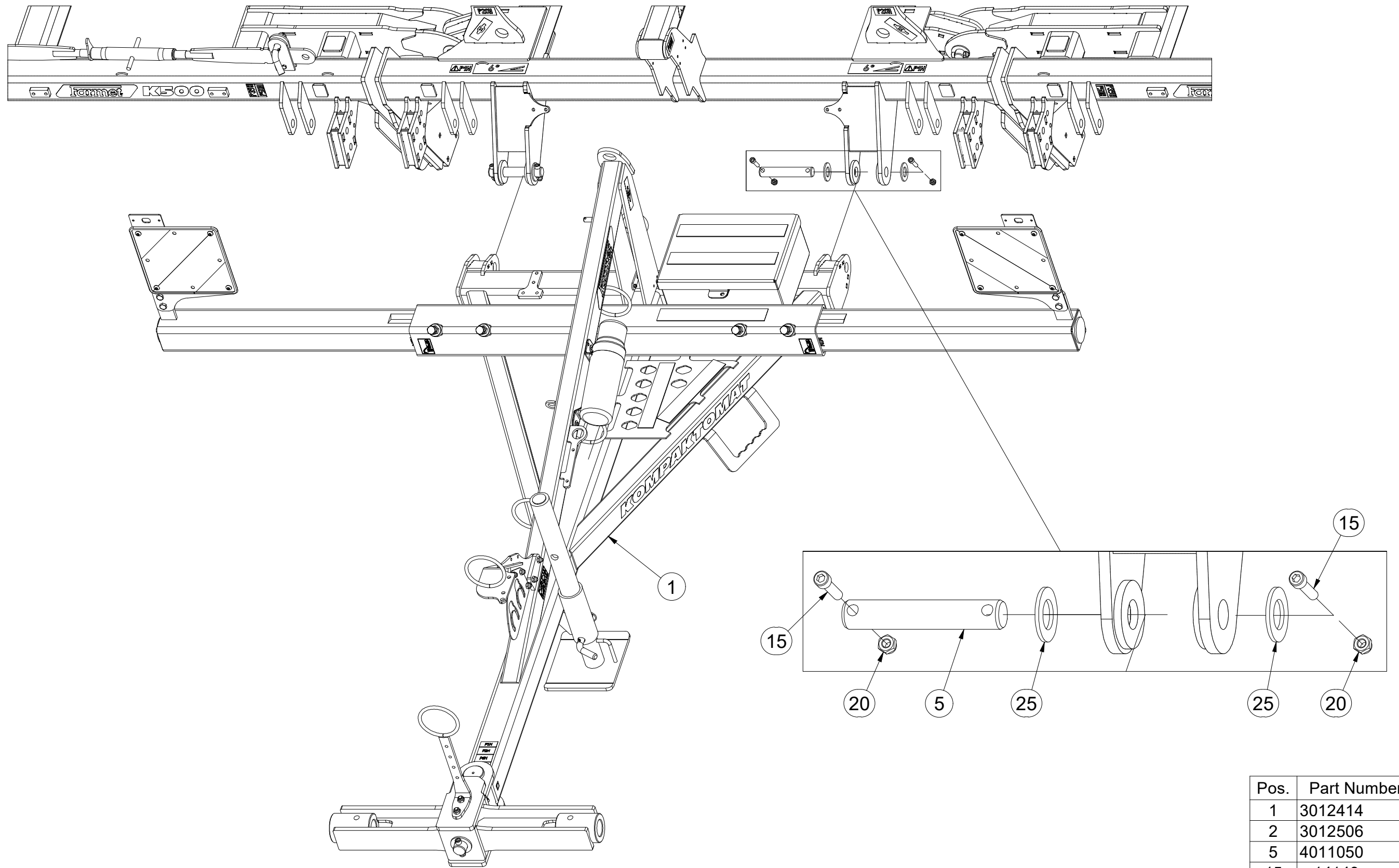

| Pos. | Part Number | Pcs. |
|------|-------------|------|
| 1 | 3012414 | 1 |
| 2 | 3012506 | 1 |
| 5 | 4011050 | 2 |
| 15 | m14143 | 4 |
| 20 | m03775 | 4 |
| 25 | m14029 | 4 |

☉ POLOTOVAR STROJE

☐ MASCHINEN-HALBFABRIKAT

☉ MACHINE - SEMI-PRODUIT

☉ SEMIFINISHED MACHINE

☉ ПОЛУФАБРИКАТ МАШИНЫ

☉ PÓLFABRYKAT MASZYNY



3012506

| Pos. | Part Number | Pcs. |
|------|-------------|------|
| 1 | 2001191 | 1 |
| 2 | 6000467 | 1 |
| 3 | 6000468 | 1 |
| 13 | m10454 | 2 |
| 21 | 4016427 | 2 |
| 30 | m02579 | 2 |
| 32 | m11099 | 16 |
| 33 | m12467 | 1 |
| 70 | m19066 | 1 |

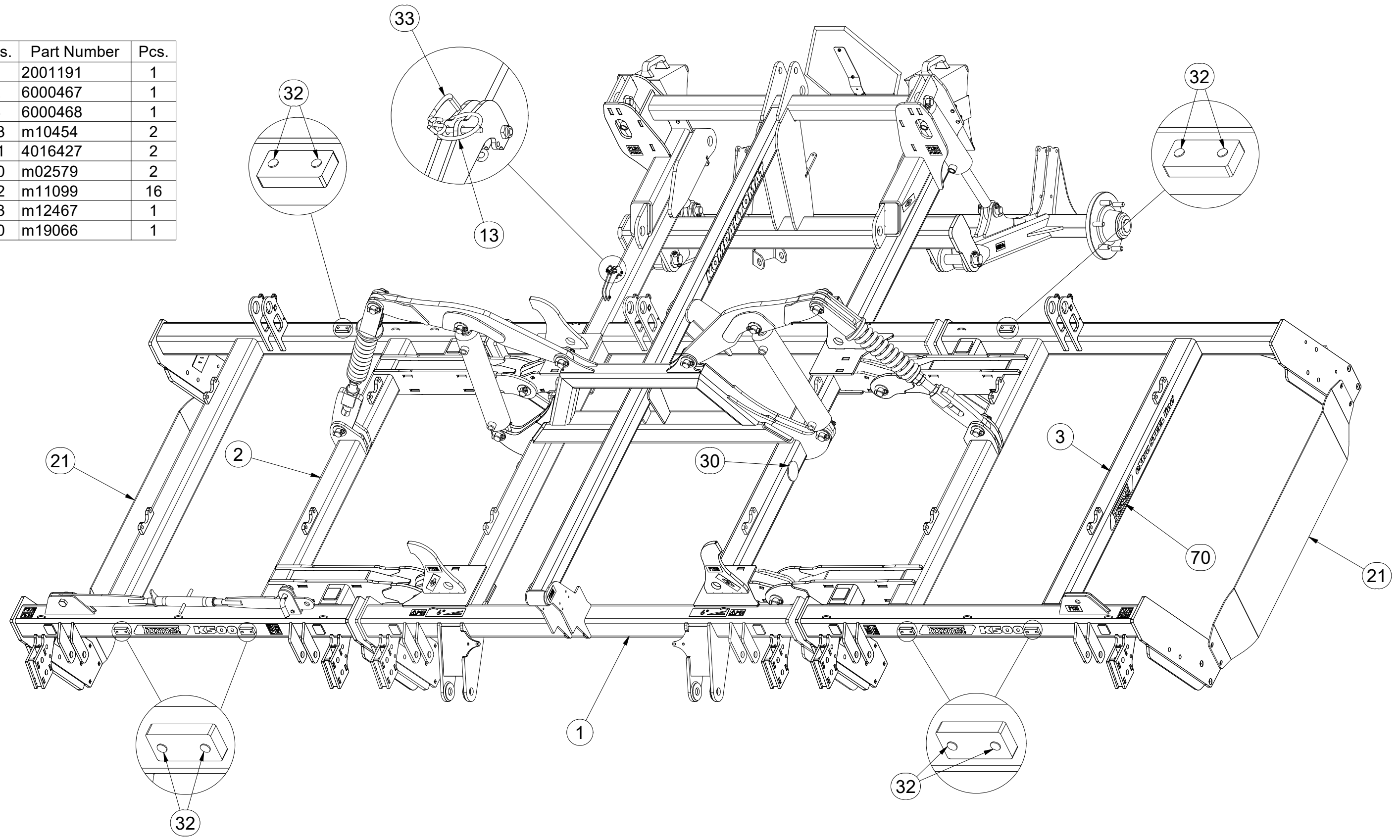

Ⓒ POLOTOVAR STROJE

Ⓓ MASCHINEN-HALBFABRIKAT

Ⓕ MACHINE - SEMI-PRODUIT

Ⓖ SEMIFINISHED MACHINE

Ⓡ ПОЛУФАБРИКАТ МАШИНЫ

Ⓢ РОЉФАБРИКАТ MASZYNY



3012506

| Pos. | Part Number | Pcs. | Pos. | Part Number | Pcs. |
|------|-------------|------|------|-------------|------|
| 2 | 6000467 | 1 | 30 | m02579 | 2 |
| 5 | 4005363 | 2 | 42 | m01096 | 1 |
| 6 | 4021664 | 2 | 43 | m14143 | 36 |
| 9 | 4003966 | 1 | 45 | m04241 | 1 |
| 11 | 4014569 | 2 | 51 | m04503 | 9 |
| 12 | 4012011 | 1 | 52 | m03775 | 36 |
| 13 | m10454 | 2 | 54 | m05648 | 1 |
| 17 | 4007584 | 2 | 55 | m04043 | 2 |
| 19 | 4007641 | 4 | 61 | m14029 | 36 |
| 21 | 4016427 | 2 | | | |

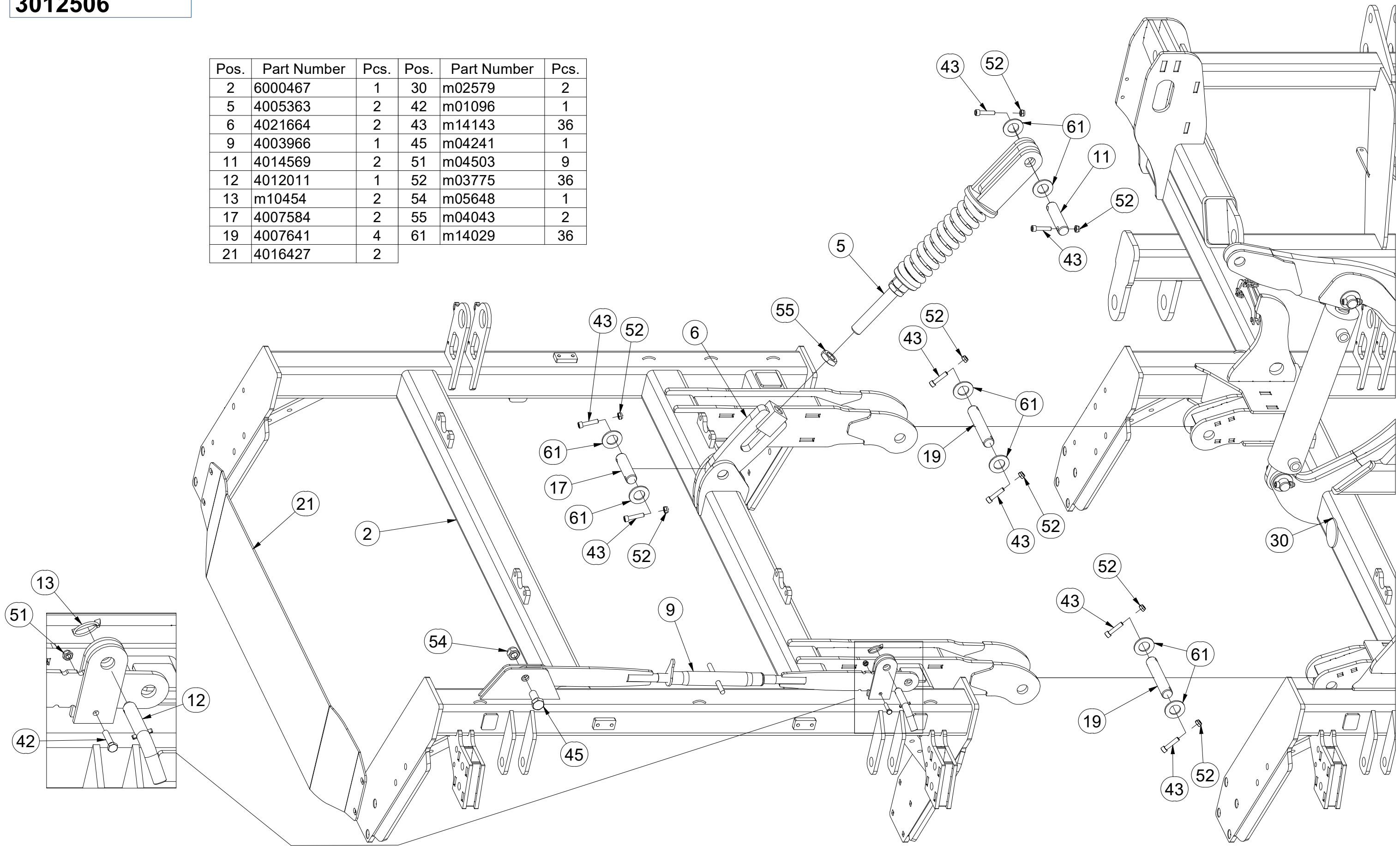

Ⓒ POLOTOVAR STROJE

Ⓓ MASCHINEN-HALBFABRIKAT

Ⓕ MACHINE - SEMI-PRODUIT

Ⓖ SEMIFINISHED MACHINE

Ⓡ ПОЛУФАБРИКАТ МАШИНЫ

Ⓟ PÓLFABRYKAT MASZYN



3012506

| Pos. | Part Number | Pcs. | Pos. | Part Number | Pcs. |
|------|-------------|------|------|-------------|------|
| 3 | 6000468 | 1 | 21 | 4016427 | 2 |
| 5 | 4005363 | 2 | 30 | m02579 | 2 |
| 6 | 4021664 | 2 | 43 | m14143 | 36 |
| 11 | 4014569 | 2 | 52 | m03775 | 36 |
| 17 | 4007584 | 2 | 55 | m04043 | 2 |
| 19 | 4007641 | 4 | 61 | m14029 | 36 |

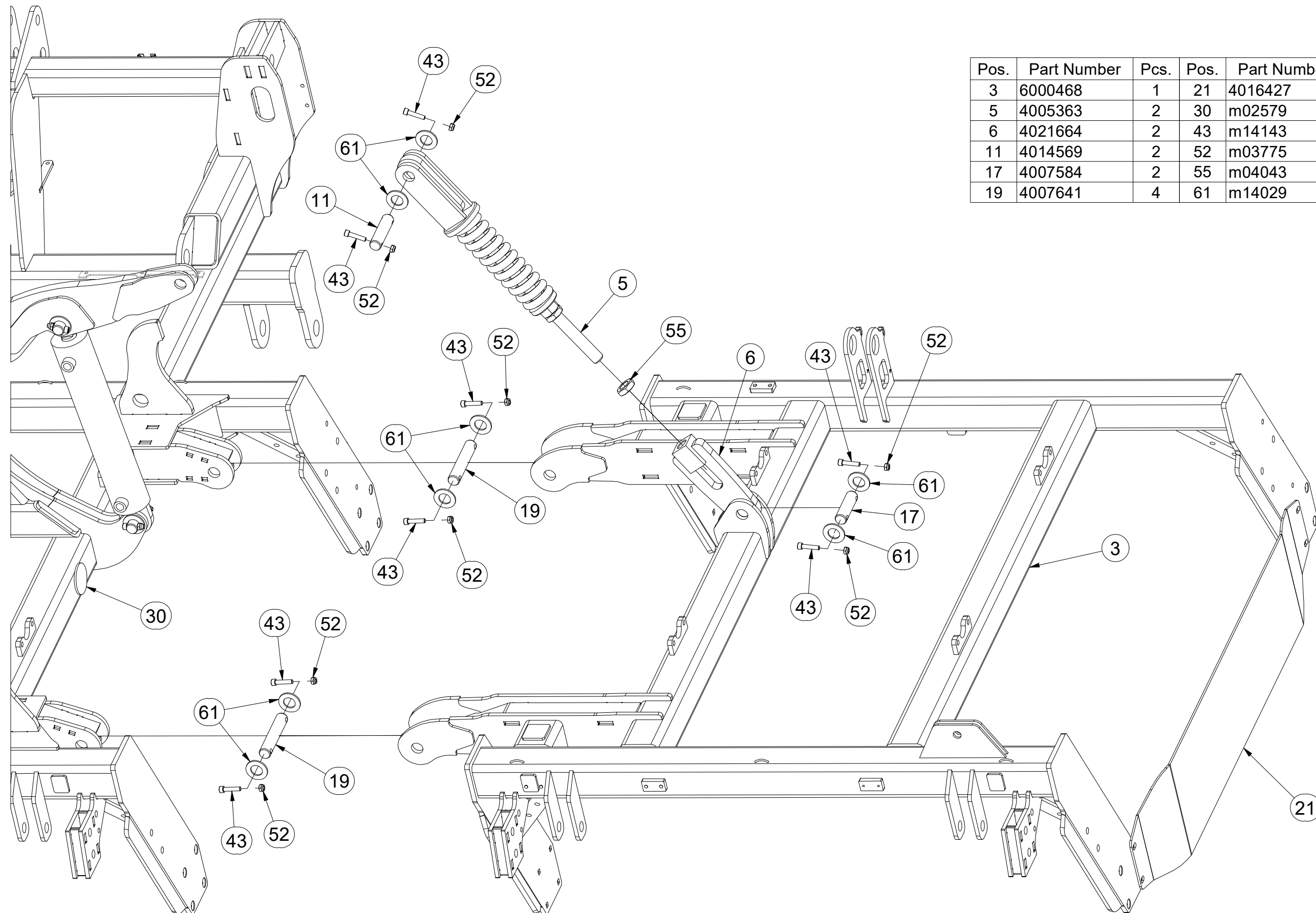

☉ POLOTOVAR STROJE

☉ MASCHINEN-HALBFABRIKAT

☉ MACHINE - SEMI-PRODUIT

☉ SEMIFINISHED MACHINE

☉ ПОЛУФАБРИКАТ МАШИНЫ

☉ PÓLFABRYKAT MASZYNY



3012506

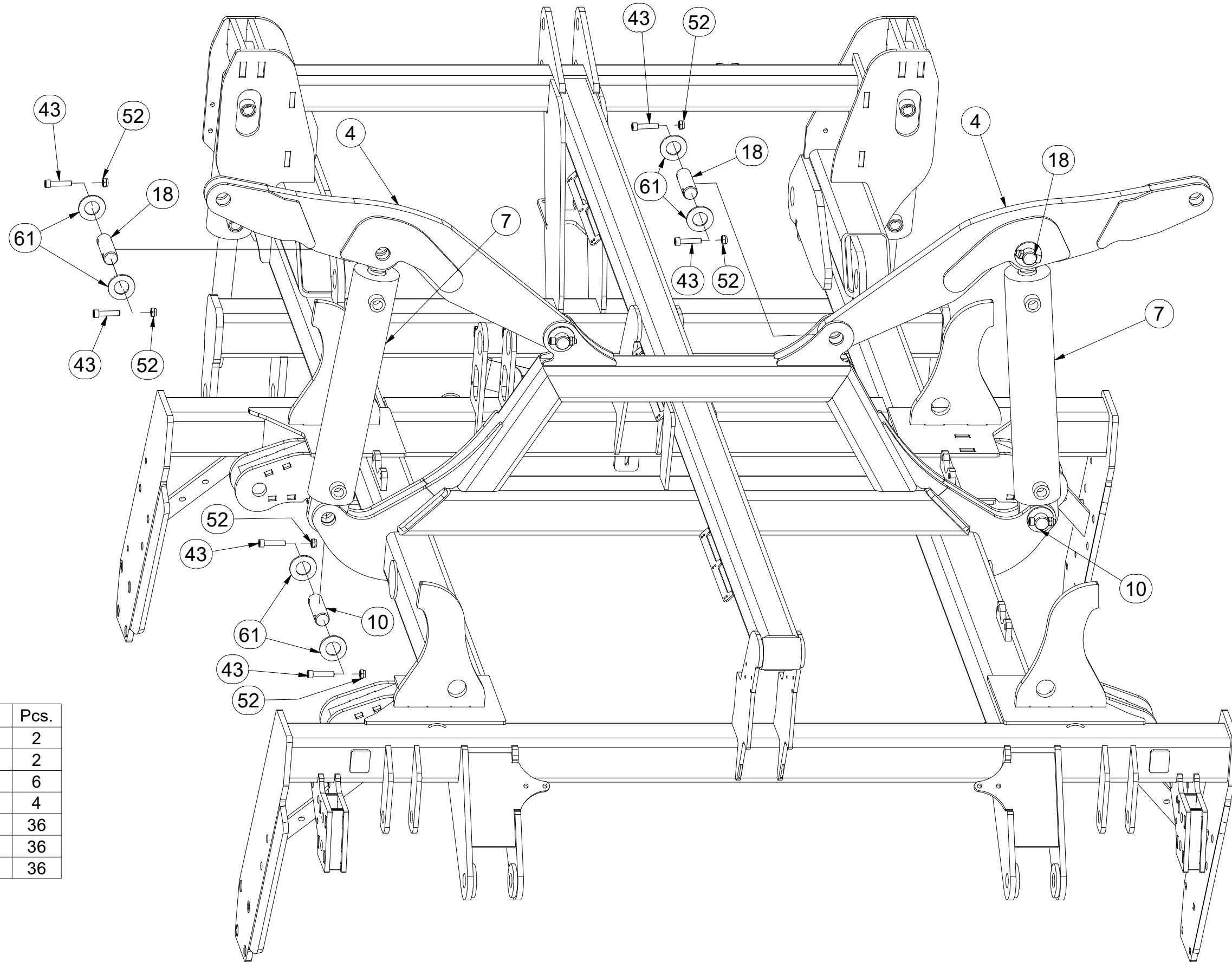

| Pos. | Part Number | Pcs. |
|------|-------------|------|
| 4 | 3002837 | 2 |
| 7 | VZ00004544 | 2 |
| 10 | 4008234 | 6 |
| 18 | 4007640 | 4 |
| 43 | m14143 | 36 |
| 52 | m03775 | 36 |
| 61 | m14029 | 36 |

Ⓒ POLOTOVAR STROJE

Ⓓ MASCHINEN-HALBFABRIKAT

Ⓕ MACHINE - SEMI-PRODUIT

Ⓖ SEMIFINISHED MACHINE

Ⓡ ПОЛУФАБРИКАТ МАШИНЫ

Ⓟ PÓLFABRYKAT MASZYNY



3012506

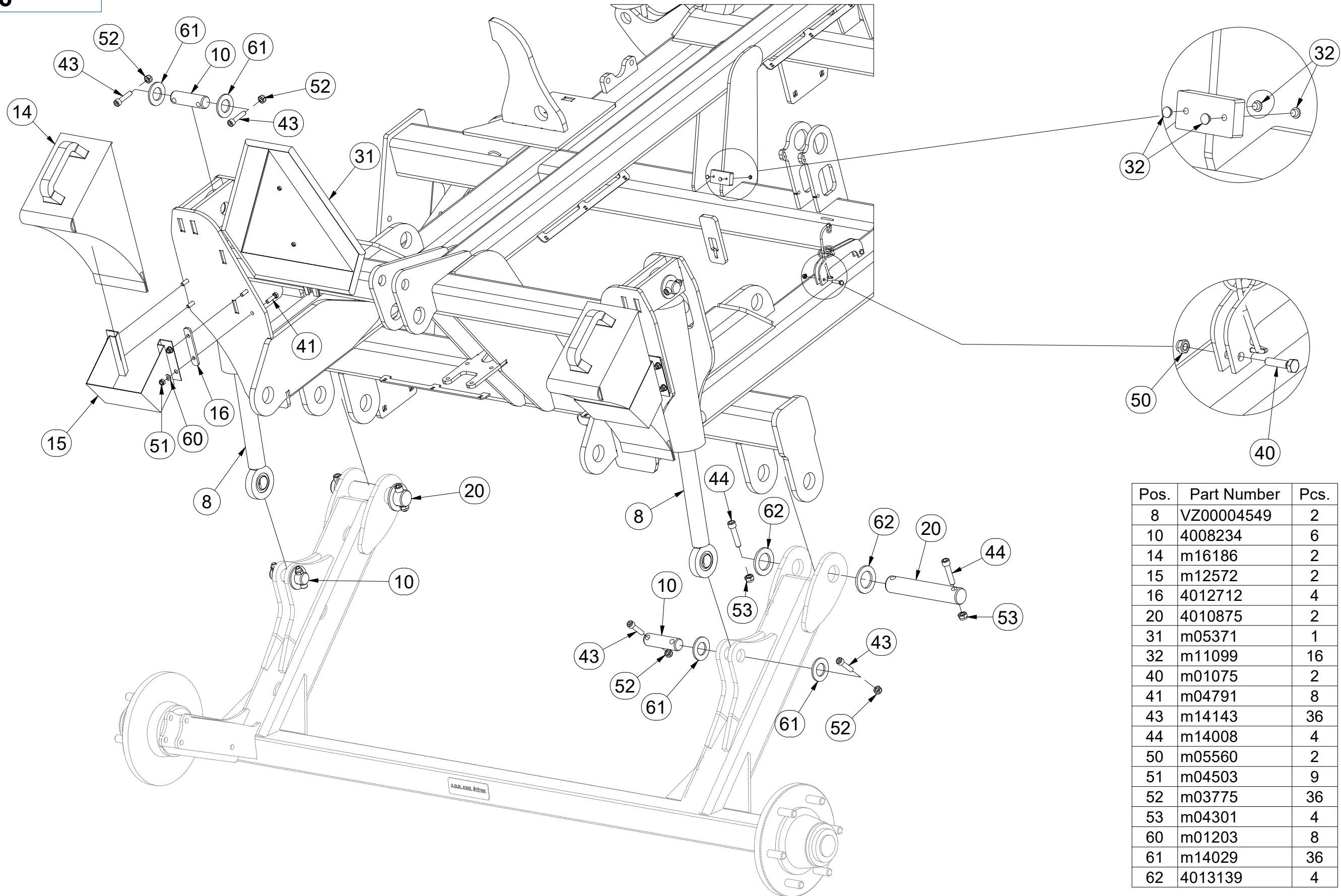

| Pos. | Part Number | Pcs. |
|------|-------------|------|
| 8 | VZ00004549 | 2 |
| 10 | 4008234 | 6 |
| 14 | m16186 | 2 |
| 15 | m12572 | 2 |
| 16 | 4012712 | 4 |
| 20 | 4010875 | 2 |
| 31 | m05371 | 1 |
| 32 | m11099 | 16 |
| 40 | m01075 | 2 |
| 41 | m04791 | 8 |
| 43 | m14143 | 36 |
| 44 | m14008 | 4 |
| 50 | m05560 | 2 |
| 51 | m04503 | 9 |
| 52 | m03775 | 36 |
| 53 | m04301 | 4 |
| 60 | m01203 | 8 |
| 61 | m14029 | 36 |
| 62 | 4013139 | 4 |

Ⓒ SAMOLEPKY STROJE

Ⓓ AUFKLEBER MASCHINEN

Ⓕ VOITURE MACHINES

Ⓖ STICKERS MACHINES

Ⓔ СТИКЕРЫ МАШИНЫ

Ⓗ NAKLEJKI MASZYNY

Farmet

m19066

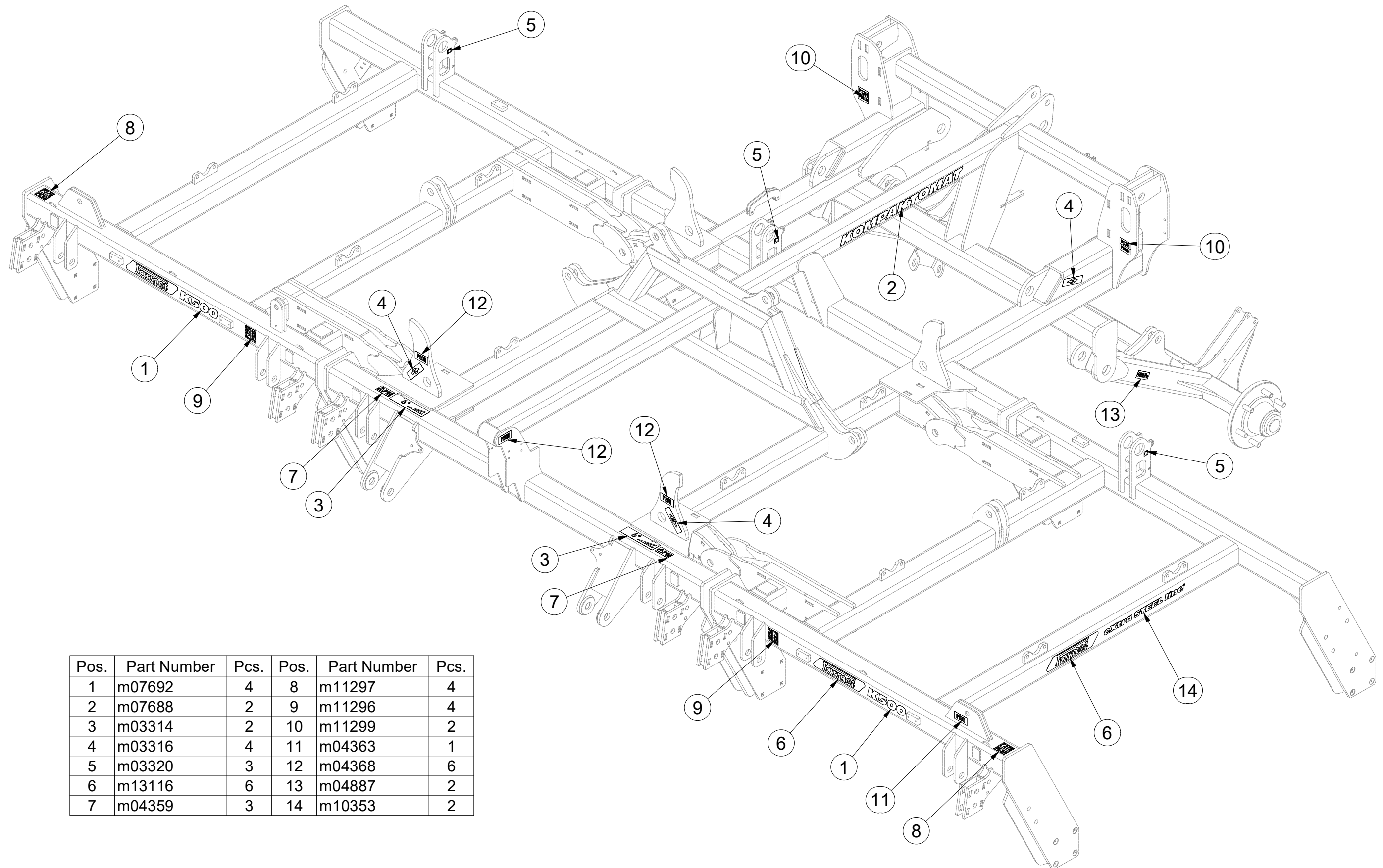

| Pos. | Part Number | Pcs. | Pos. | Part Number | Pcs. |
|------|-------------|------|------|-------------|------|
| 1 | m07692 | 4 | 8 | m11297 | 4 |
| 2 | m07688 | 2 | 9 | m11296 | 4 |
| 3 | m03314 | 2 | 10 | m11299 | 2 |
| 4 | m03316 | 4 | 11 | m04363 | 1 |
| 5 | m03320 | 3 | 12 | m04368 | 6 |
| 6 | m13116 | 6 | 13 | m04887 | 2 |
| 7 | m04359 | 3 | 14 | m10353 | 2 |

Ⓒ SAMOLEPKY STROJE

Ⓓ AUFKLEBER MASCHINEN

Ⓕ VOITURE MACHINES

Ⓖ STICKERS MACHINES

Ⓡ СТИКЕРЫ МАШИНЫ

Ⓟ NAKLEJKI MASZYNY



m19066

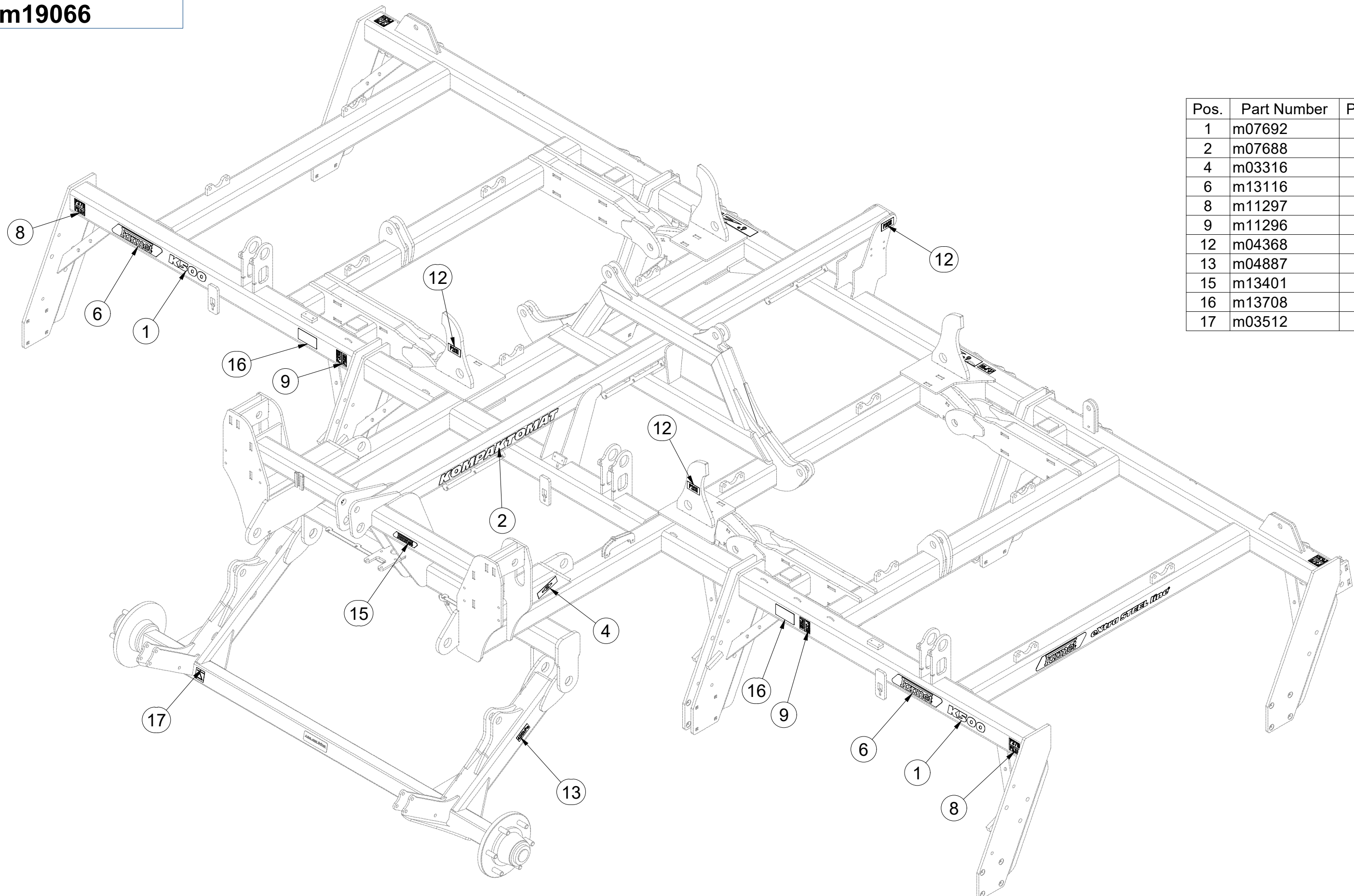

| Pos. | Part Number | Pcs. |
|------|-------------|------|
| 1 | m07692 | 4 |
| 2 | m07688 | 2 |
| 4 | m03316 | 4 |
| 6 | m13116 | 6 |
| 8 | m11297 | 4 |
| 9 | m11296 | 4 |
| 12 | m04368 | 6 |
| 13 | m04887 | 2 |
| 15 | m13401 | 1 |
| 16 | m13708 | 2 |
| 17 | m03512 | 2 |

Ⓒ CZ TÁHLO SKLÁPĚNÍ

Ⓓ ZUGSTANGE ZUR KIPPUNG

Ⓕ TIGES DE L'ESSIEU

4005363

Ⓖ GB TILTING PULL ROD

Ⓡ RU ТЯГИ ТРАНСПОРТНОЙ ОСИ

Ⓟ PL SPRZĘGI OSI

Farmet

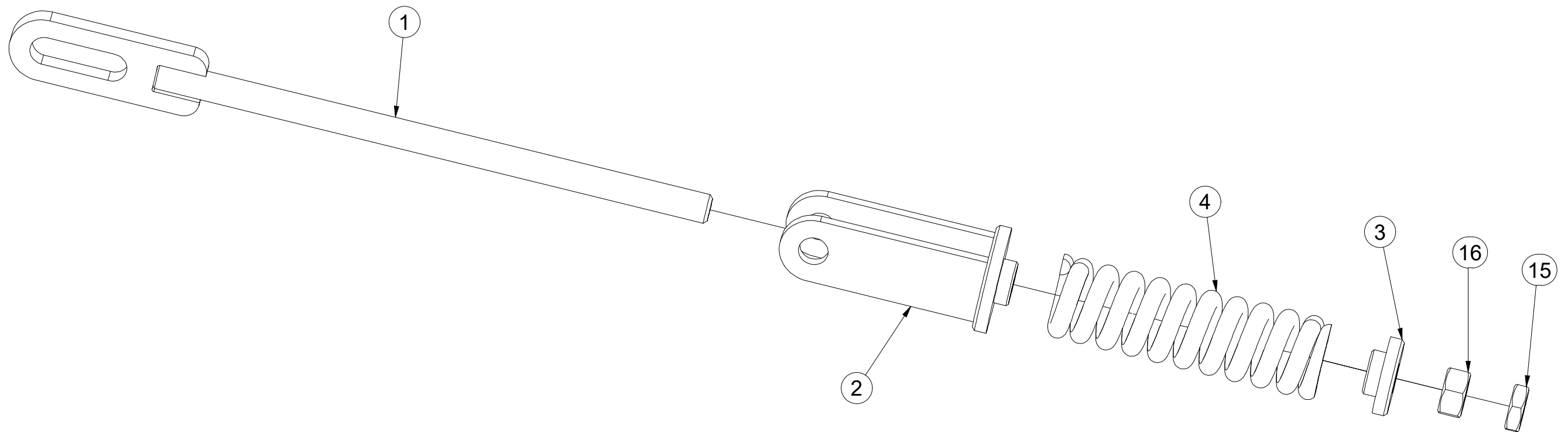
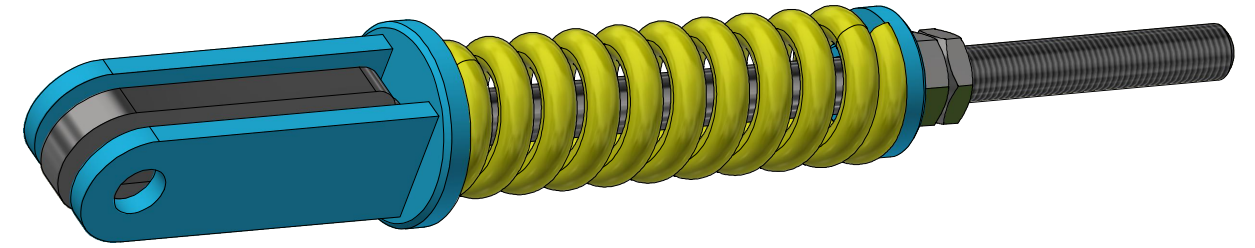

| Pos. | Part Number | Pcs. |
|------|-------------|------|
| 1 | 4005358 | 1 |
| 2 | 4005361 | 1 |
| 3 | 4000023 | 1 |
| 4 | m06482 | 1 |
| 15 | m04043 | 1 |
| 16 | m01309 | 1 |

Ⓒ SPOJOVACÍ TÁHLO
Ⓓ VERBINDUNGSSTANGE
Ⓕ TIGE DE RACCORDEMENT

Ⓖ CONNECTING ROD
Ⓡ СОЕДИНИТЕЛЬНАЯ ТЯГА
Ⓟ KORBOWÓD



4003966

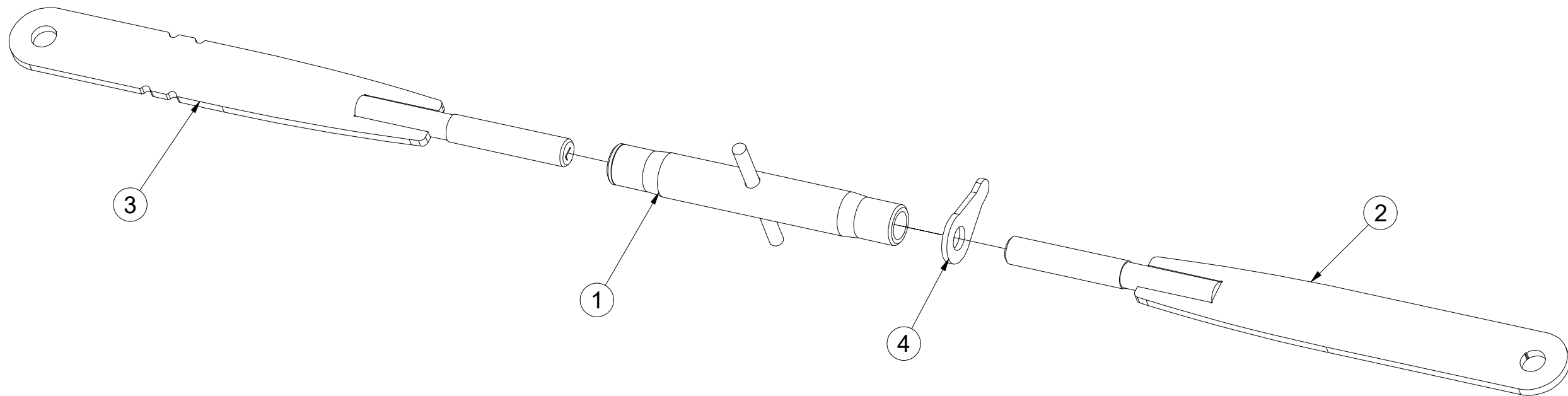
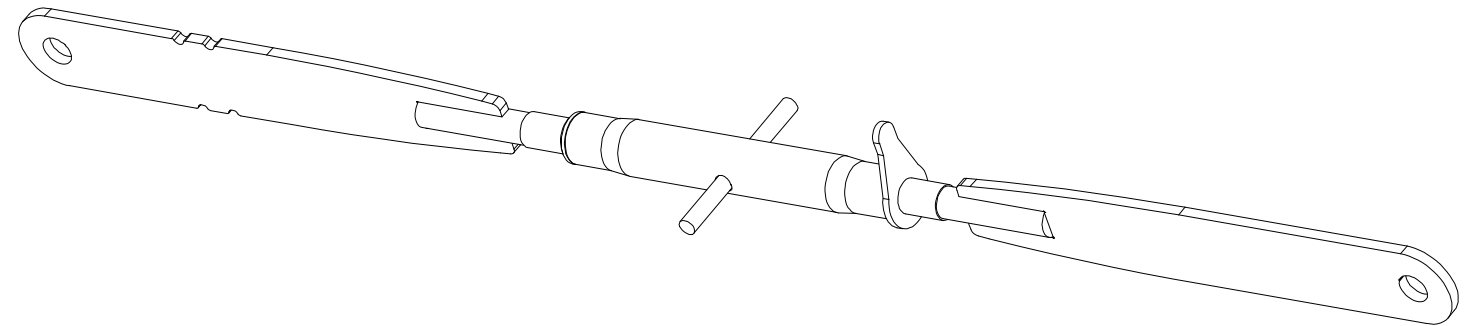

| Pos. | Part Number | Pcs. |
|------|-------------|------|
| 1 | m08880 | 1 |
| 2 | 4023421 | 1 |
| 3 | 4023423 | 1 |
| 4 | m08881 | 1 |

Ⓒ HYDRAULIKA STROJE

Ⓓ HYDRAULIK DER MASCHINE

Ⓕ HYDRAULIQUE DE LA MACHINE

Ⓖ MACHINE HYDRAULICS

Ⓡ ГИДРАВЛИКА МАШИНЫ

Ⓟ HYDRAULIKA MASZYN



3011328

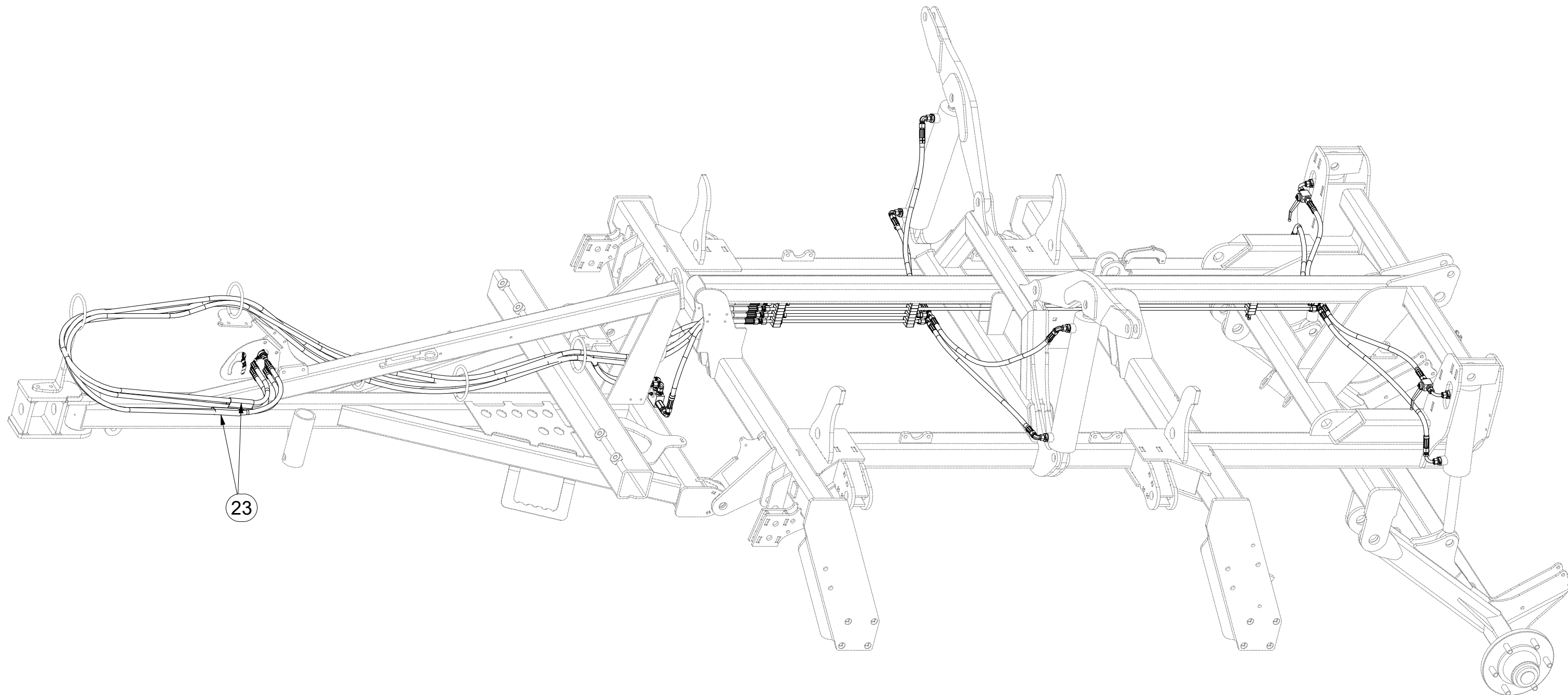

| Pos. | Part Number | Pcs. |
|------|-------------|------|
| 23 | m11183 | 2 |

ⒸZ HYDRAULIKA STROJE

Ⓓ HYDRAULIK DER MASCHINE

Ⓕ HYDRAULIQUE DE LA MACHINE

ⒼB MACHINE HYDRAULICS

Ⓔ RU ГИДРАВЛИКА МАШИНЫ

Ⓗ PL HYDRAULIKA MASZYN



3011328

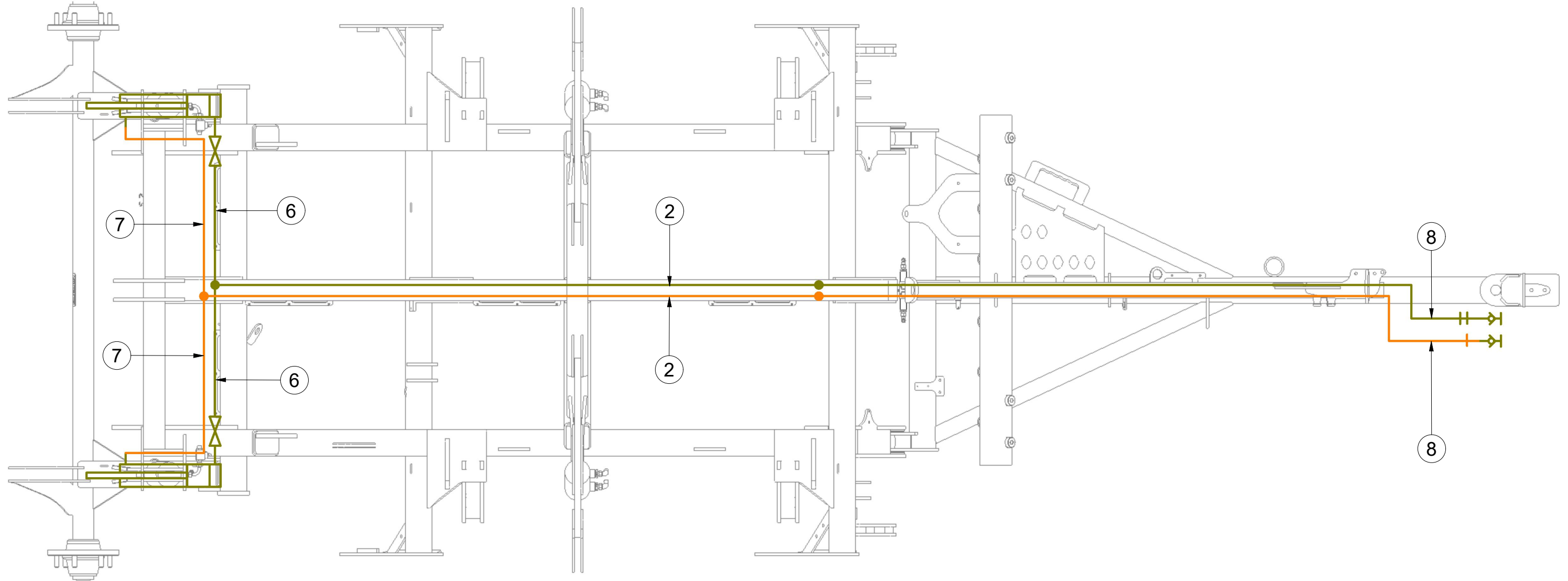

| Pos. | Part Number | Pcs. |
|------|-------------|------|
| 2 | m04803 | 2 |
| 6 | m03713 | 4 |
| 7 | m04033 | 2 |
| 8 | m09431 | 2 |

ⒸZ HYDRAULIKA STROJE

ⒸD HYDRAULIK DER MASCHINE

ⒸF HYDRAULIQUE DE LA MACHINE

ⒸGB MACHINE HYDRAULICS

ⒸRU ГИДРАВЛИКА МАШИНЫ

ⒸPL HYDRAULIKA MASZYNY



3011328

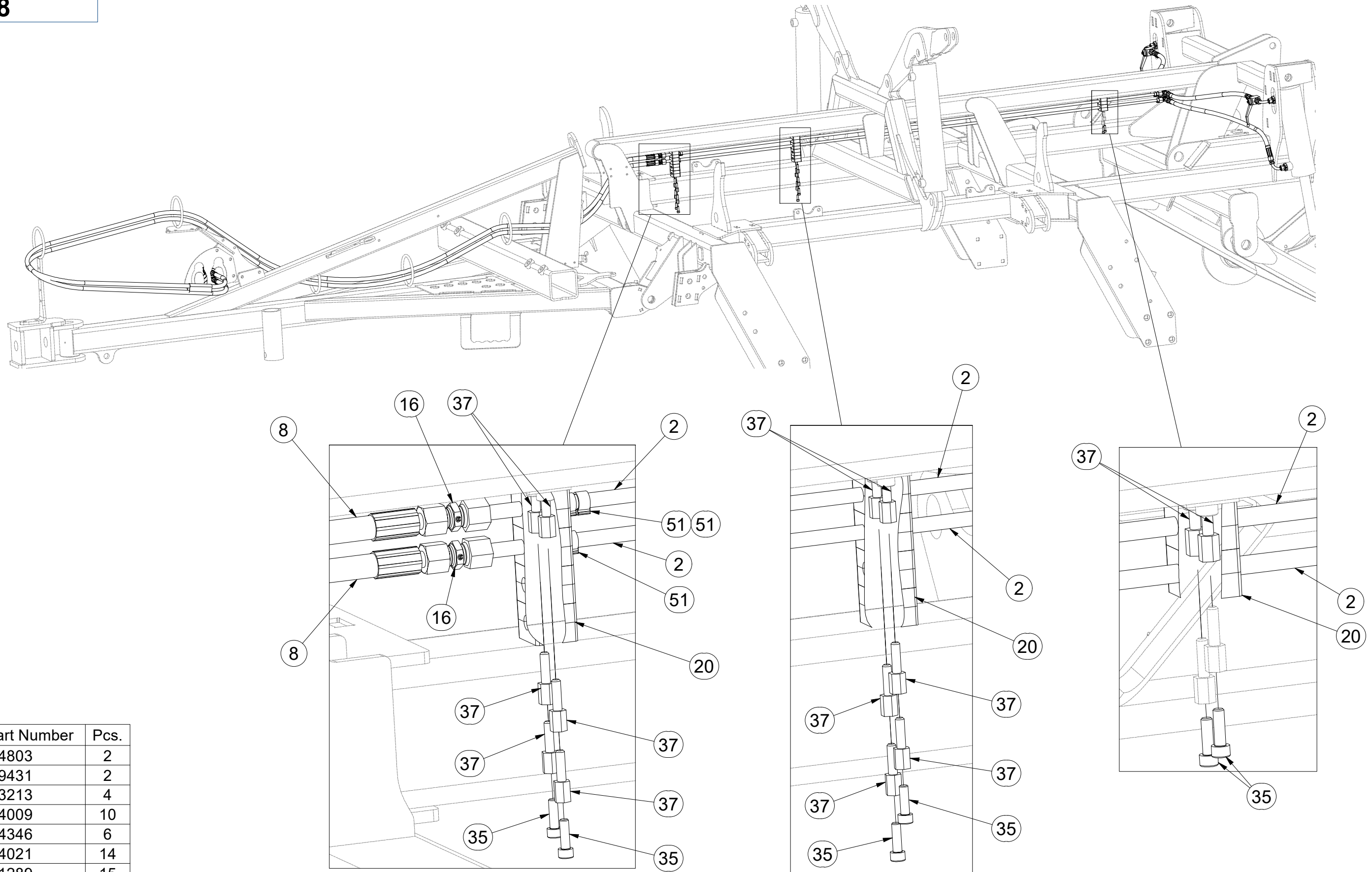

| Pos. | Part Number | Pcs. |
|------|-------------|------|
| 2 | m04803 | 2 |
| 8 | m09431 | 2 |
| 16 | m03213 | 4 |
| 20 | m04009 | 10 |
| 35 | m04346 | 6 |
| 37 | m04021 | 14 |
| 51 | m11289 | 15 |

ⒸZ HYDRAULIKA STROJE

Ⓓ HYDRAULIK DER MASCHINE

Ⓕ HYDRAULIQUE DE LA MACHINE

ⒼB MACHINE HYDRAULICS

Ⓔ RU ГИДРАВЛИКА МАШИНЫ

Ⓗ PL HYDRAULIKA MASZYN



3011328

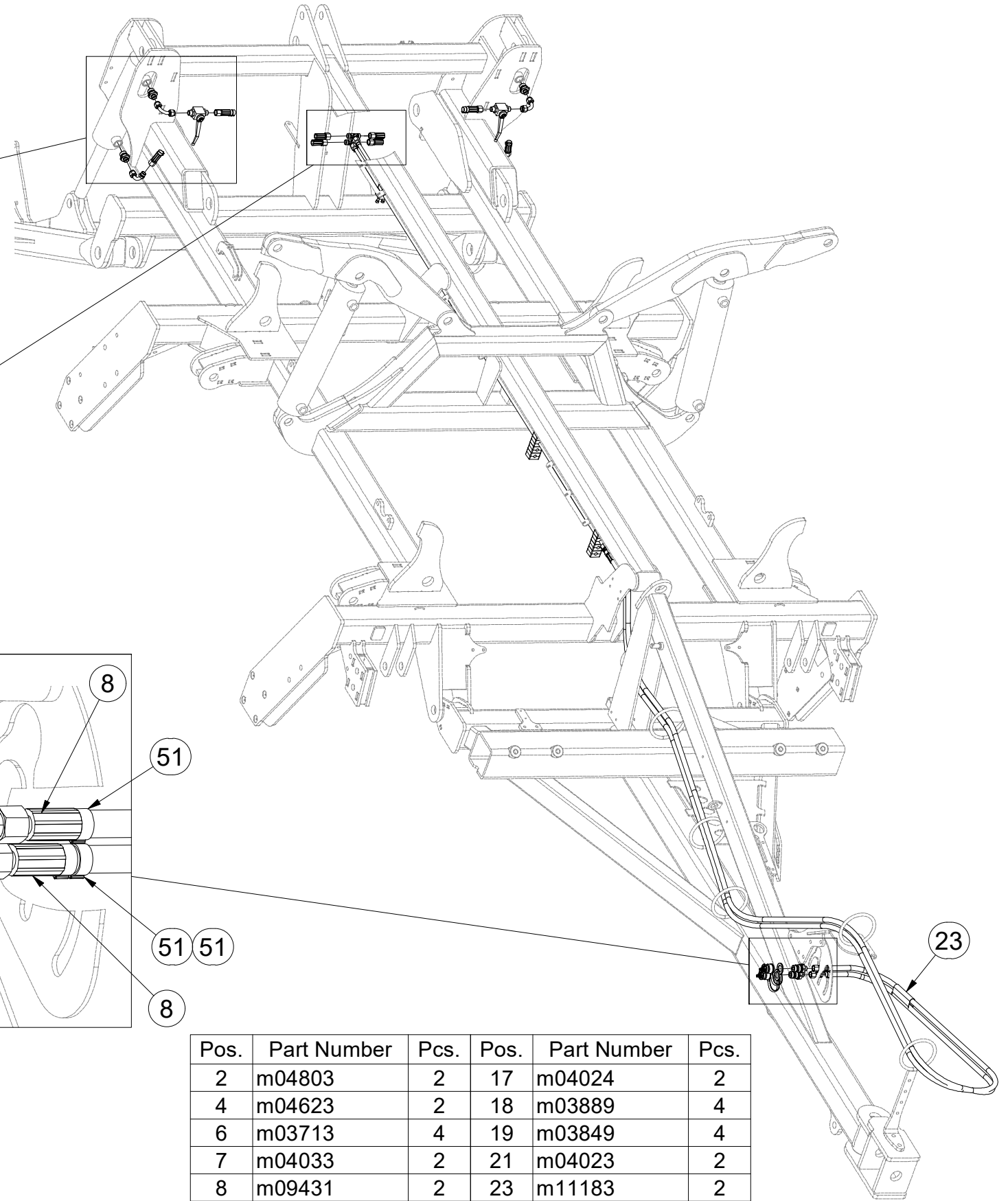
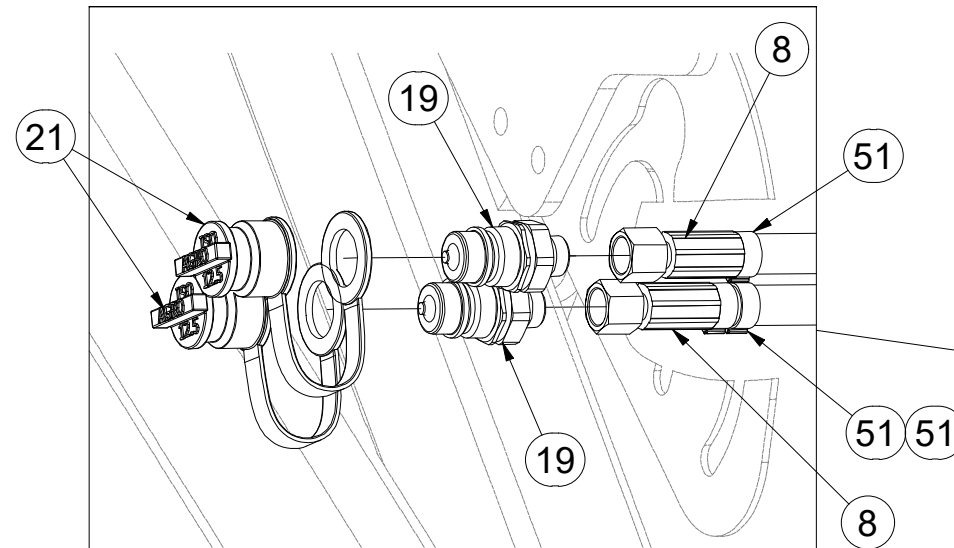
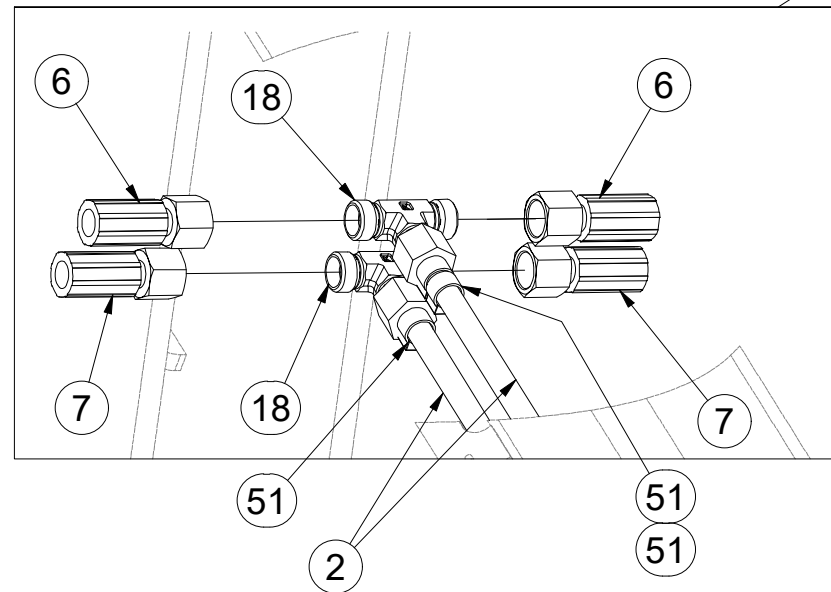
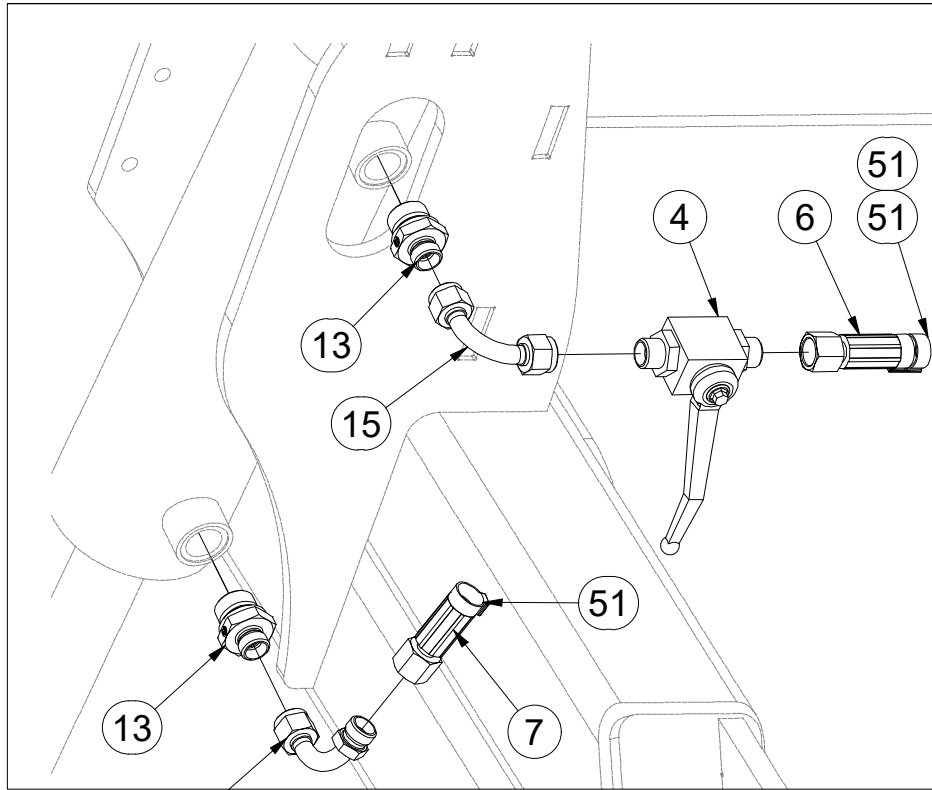

| Pos. | Part Number | Pcs. | Pos. | Part Number | Pcs. |
|------|-------------|------|------|-------------|------|
| 2 | m04803 | 2 | 17 | m04024 | 2 |
| 4 | m04623 | 2 | 18 | m03889 | 4 |
| 6 | m03713 | 4 | 19 | m03849 | 4 |
| 7 | m04033 | 2 | 21 | m04023 | 2 |
| 8 | m09431 | 2 | 23 | m11183 | 2 |
| 13 | m09934 | 8 | 51 | m11289 | 15 |
| 15 | m04621 | 2 | | | |

CZ HYDRAULIKA STROJE
 D HYDRAULIK DER MASCHINE
 F HYDRAULIQUE DE LA MACHINE

GB MACHINE HYDRAULICS
 RU ГИДРАВЛИКА МАШИНЫ
 PL HYDRAULIKA MASZYN



3011328

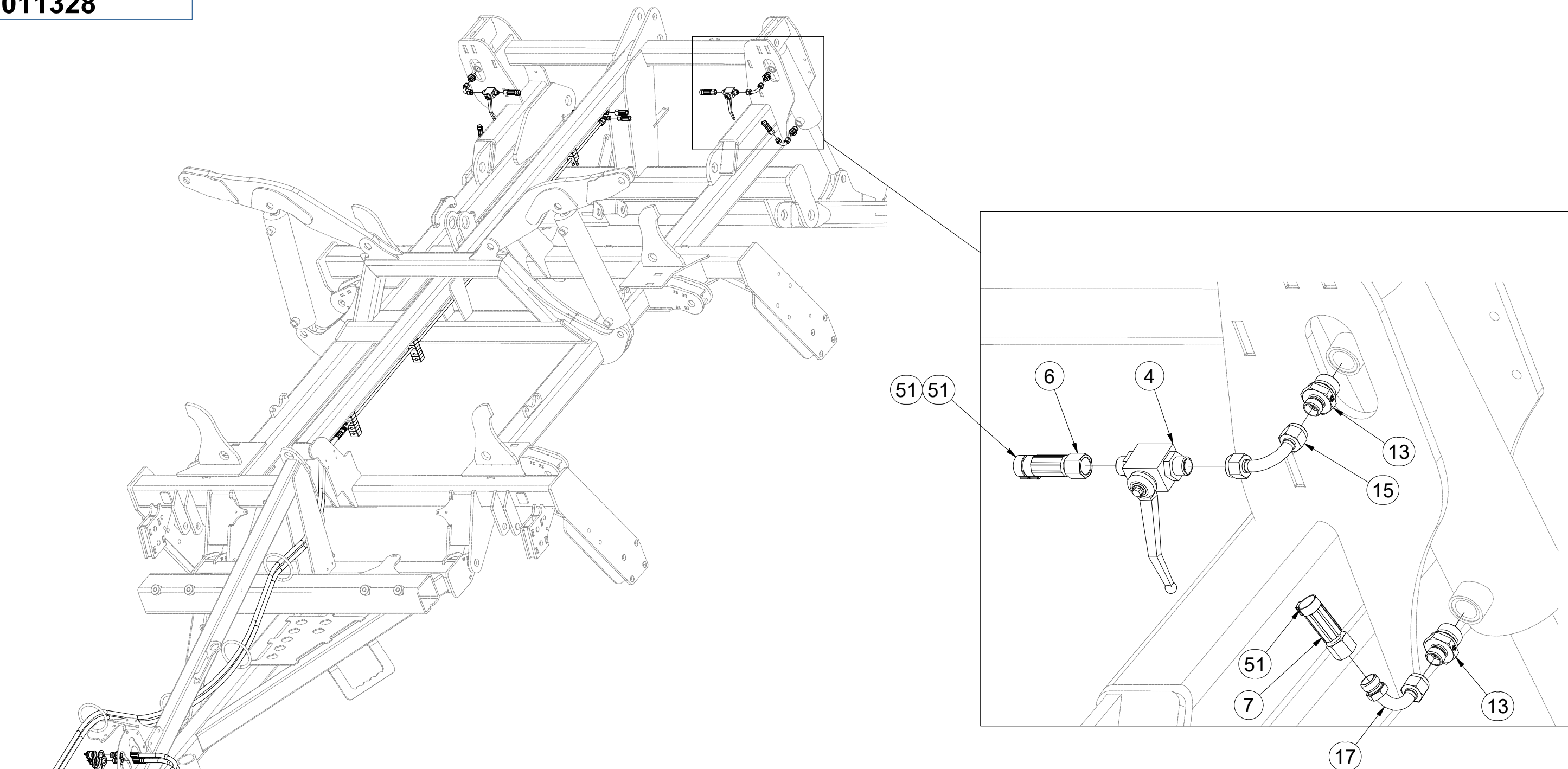

| Pos. | Part Number | Pcs. |
|------|-------------|------|
| 4 | m04623 | 2 |
| 6 | m03713 | 4 |
| 7 | m04033 | 2 |
| 13 | m09934 | 8 |
| 15 | m04621 | 2 |
| 17 | m04024 | 2 |
| 51 | m11289 | 15 |

3011328

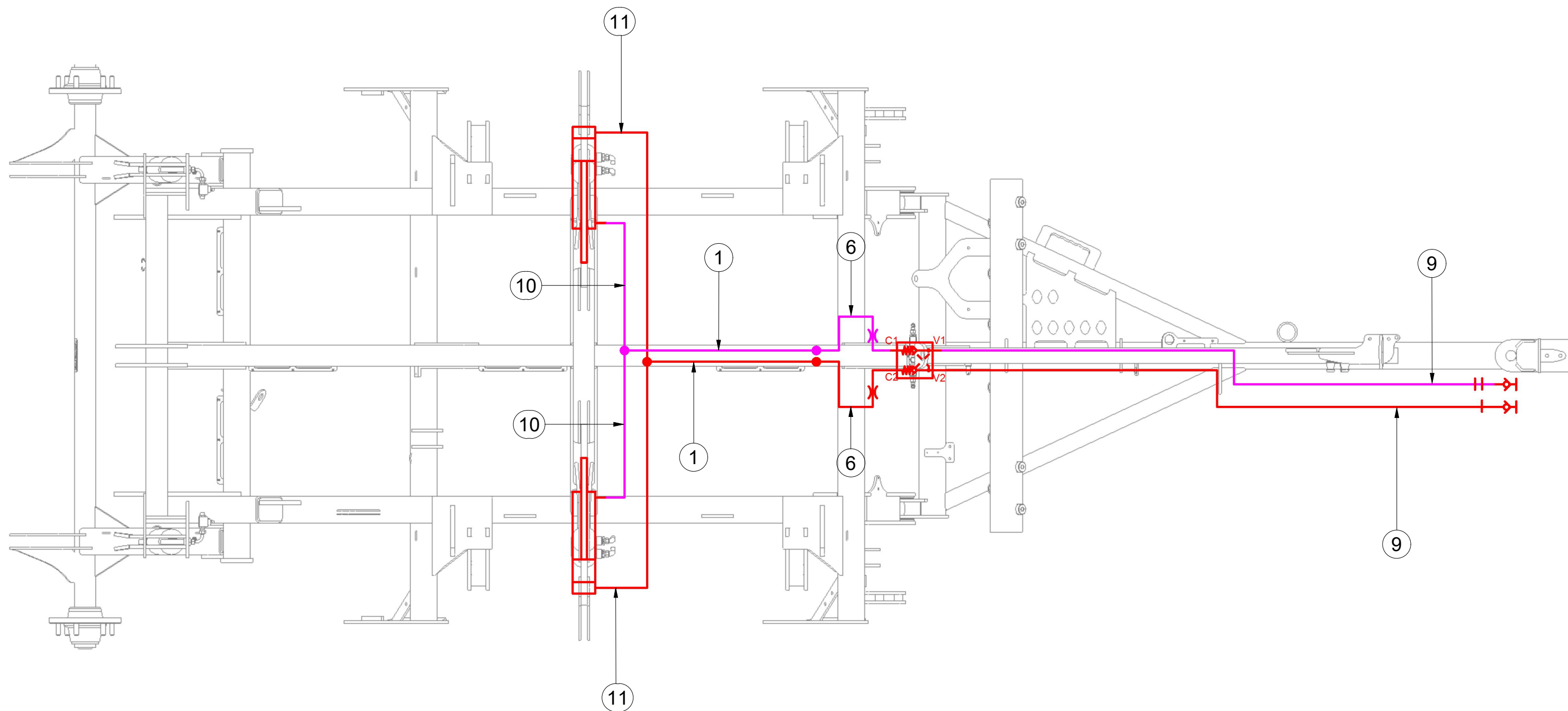

| Pos. | Part Number | Pcs. |
|------|-------------|------|
| 1 | m03975 | 2 |
| 6 | m03713 | 4 |
| 9 | m04087 | 2 |
| 10 | m07646 | 2 |
| 11 | m07909 | 2 |

3011328

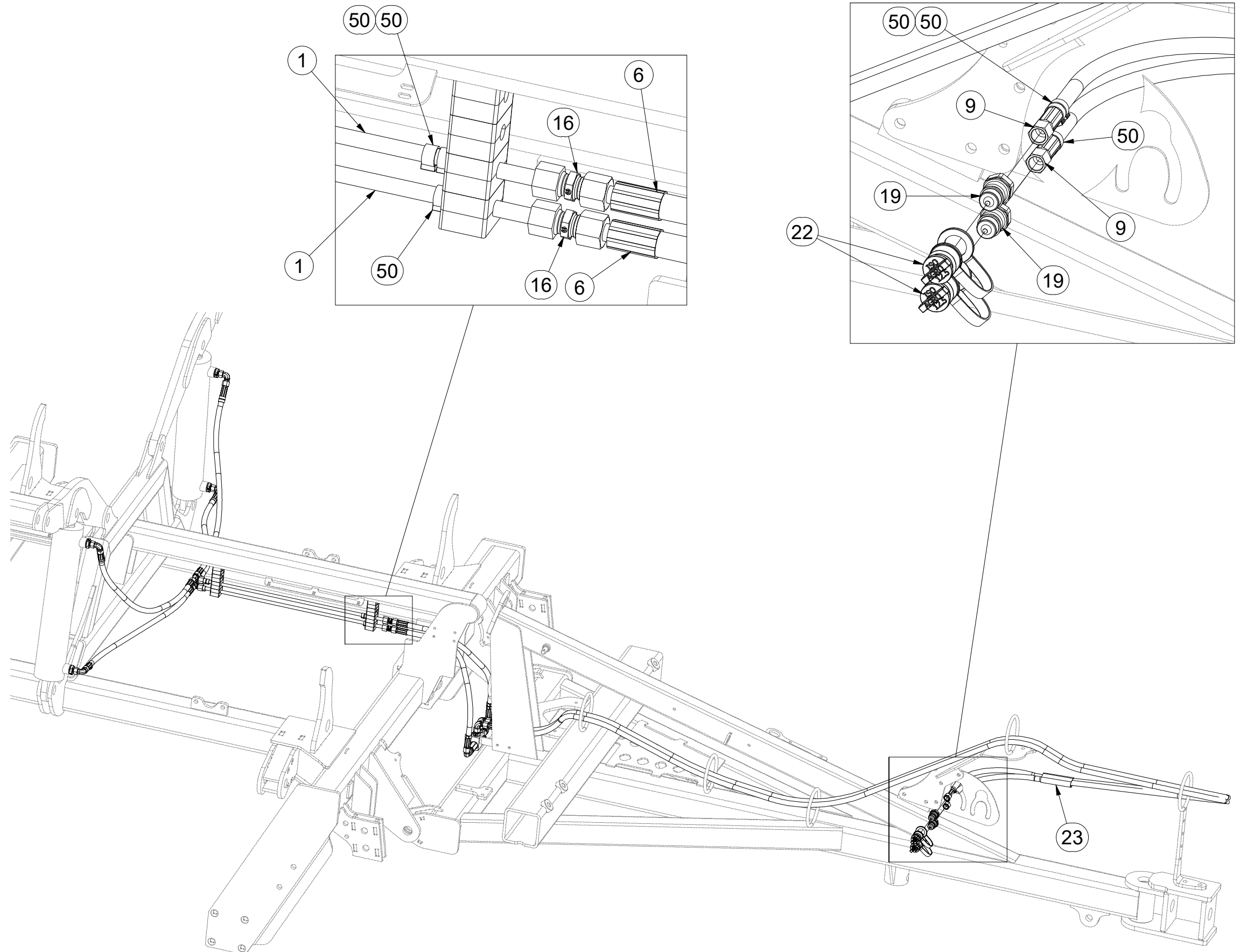

| Pos. | Part Number | Pcs. |
|------|-------------|------|
| 1 | m03975 | 2 |
| 6 | m03713 | 4 |
| 9 | m04087 | 2 |
| 16 | m03213 | 4 |
| 19 | m03849 | 4 |
| 22 | m04022 | 2 |
| 23 | m11183 | 2 |
| 50 | m11294 | 21 |

ⒸZ HYDRAULIKA STROJE

Ⓓ HYDRAULIK DER MASCHINE

Ⓕ HYDRAULIQUE DE LA MACHINE

ⒸB MACHINE HYDRAULICS

ⒸR ГИДРАВЛИКА МАШИНЫ

ⒸL HYDRAULIKA MASZYNY



3011328

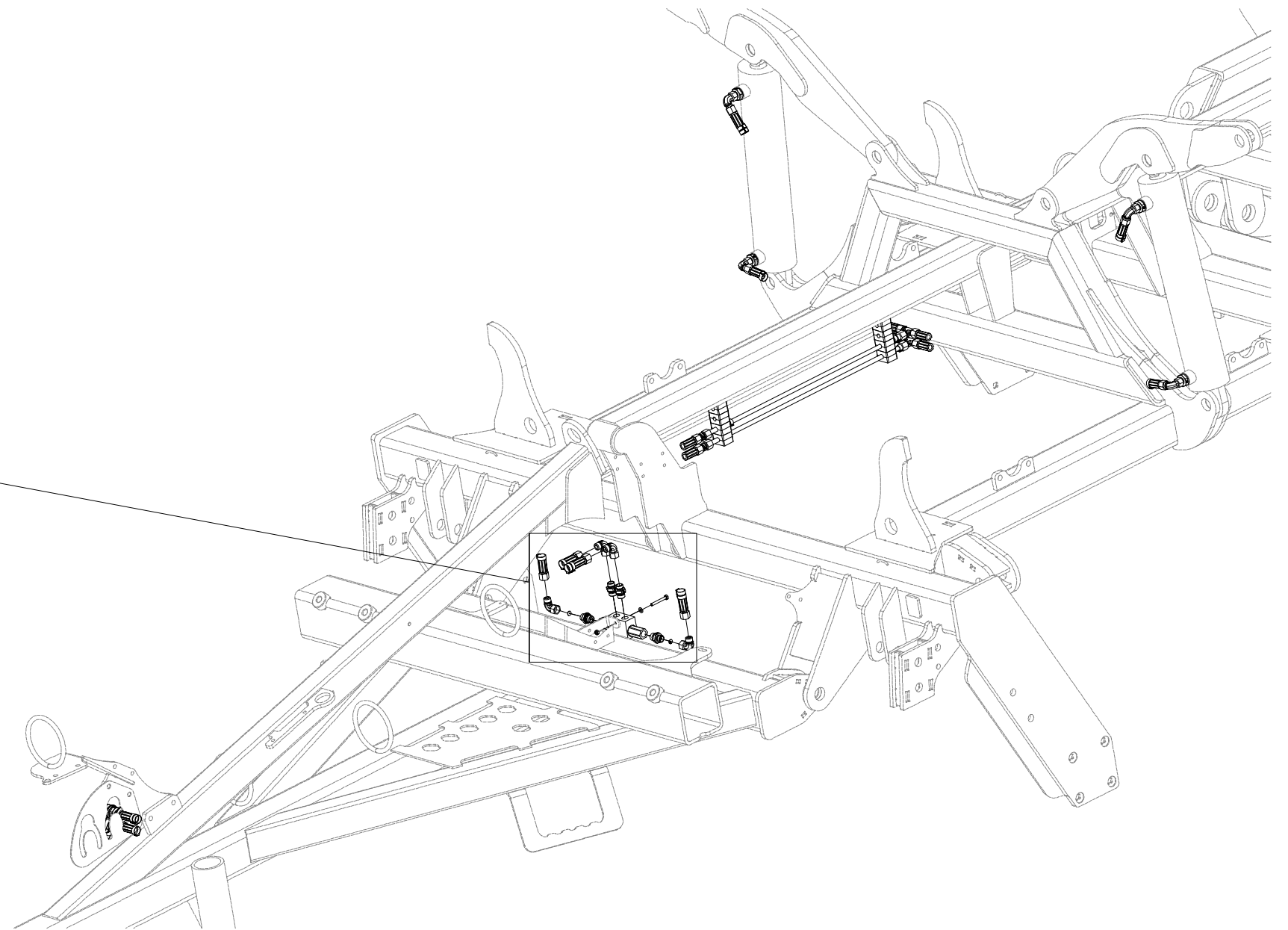
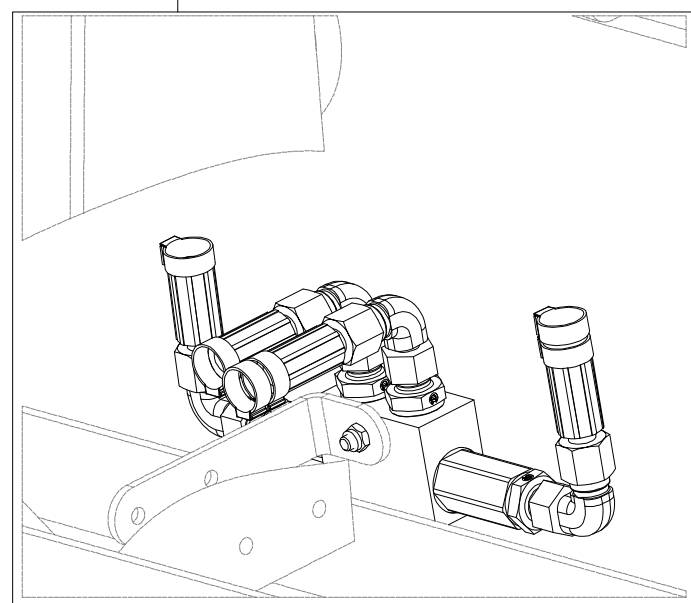
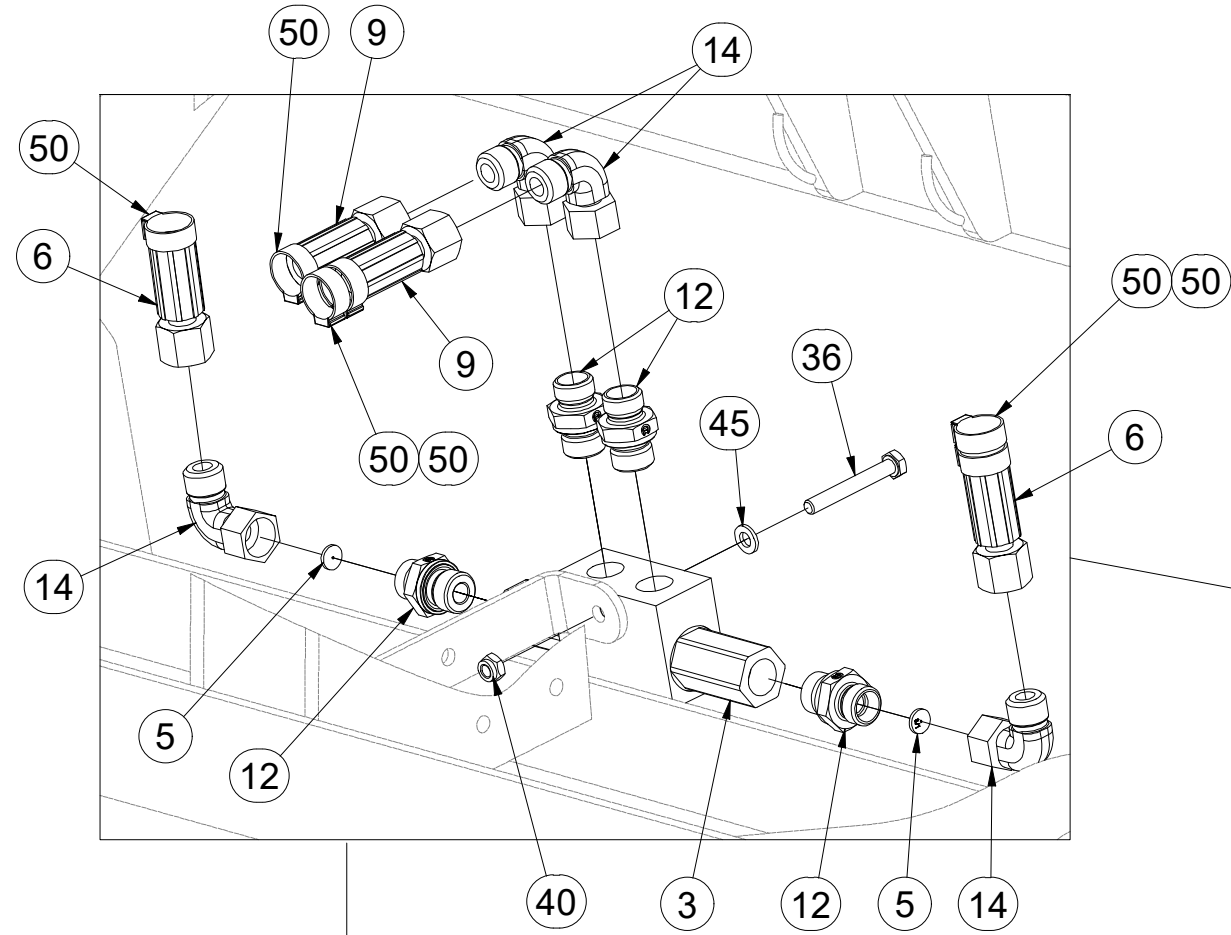

| Pos. | Part Number | Pcs. |
|------|-------------|------|
| 3 | m06673 | 1 |
| 5 | m10780 | 2 |
| 6 | m03713 | 4 |
| 9 | m04087 | 2 |
| 12 | m06528 | 4 |
| 14 | m06803 | 8 |
| 36 | m05561 | 1 |
| 40 | m05560 | 1 |
| 45 | m01199 | 1 |
| 50 | m11294 | 21 |

3011328

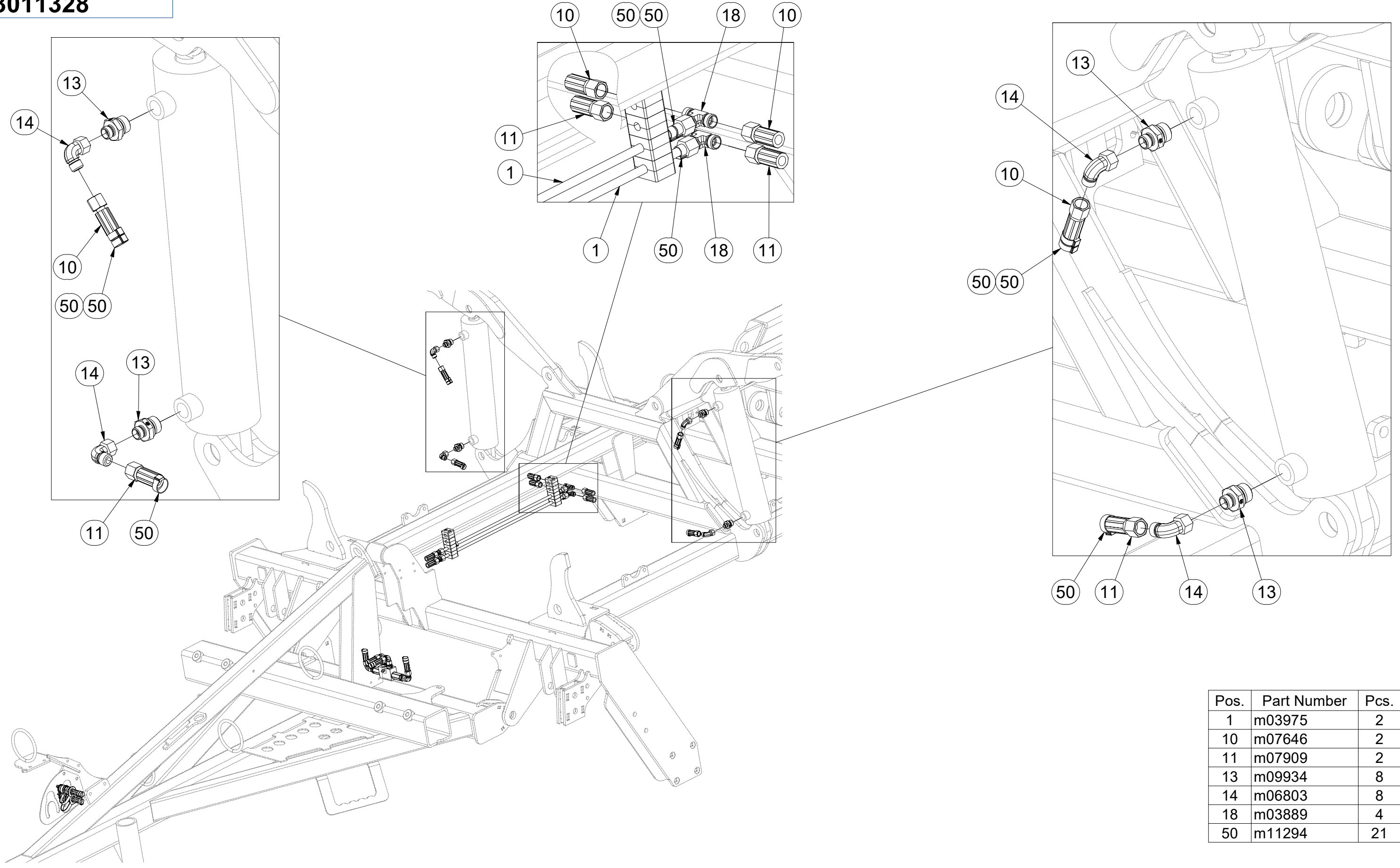

| Pos. | Part Number | Pcs. |
|------|-------------|------|
| 1 | m03975 | 2 |
| 10 | m07646 | 2 |
| 11 | m07909 | 2 |
| 13 | m09934 | 8 |
| 14 | m06803 | 8 |
| 18 | m03889 | 4 |
| 50 | m11294 | 21 |

Ⓒ CZ OJ T3

Ⓓ DEICHSEL T3

Ⓕ TIMON T3

3012414

Ⓖ GB TOW BAR T3

Ⓡ RU ДЫШЛО T3

Ⓟ PL DYSZEL T3

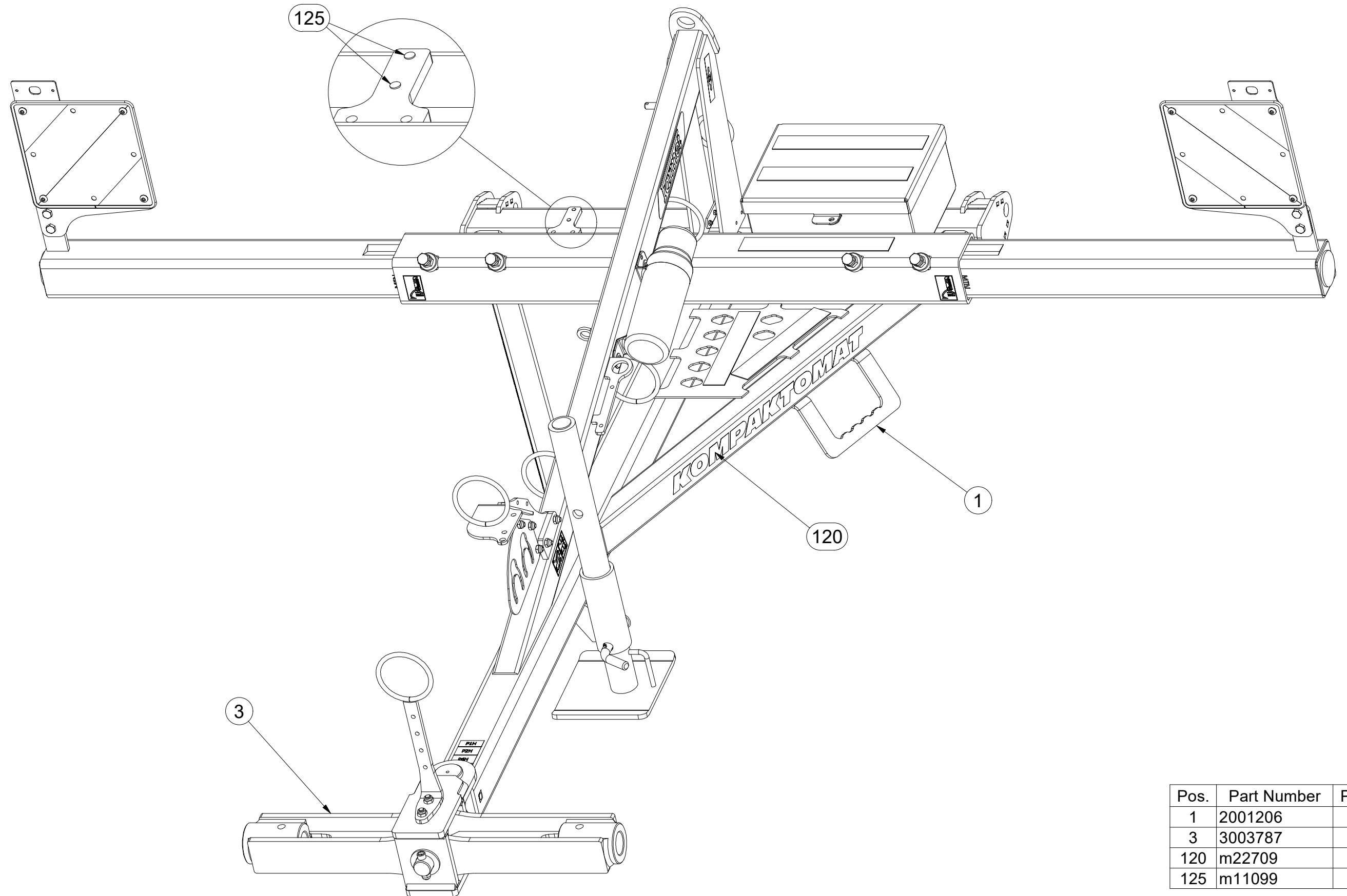

| Pos. | Part Number | Pcs. |
|------|-------------|------|
| 1 | 2001206 | 1 |
| 3 | 3003787 | 1 |
| 120 | m22709 | 1 |
| 125 | m11099 | 2 |

ⒸZ OJ T3

Ⓓ DEICHSEL T3

Ⓕ TIMON T3

ⒼB TOW BAR T3

ⒶR ДЫШЛО T3

ⒶL DYSZEL T3



3012414

| Pos. | Part Number | Pcs. | Pos. | Part Number | Pcs. |
|------|---------------|------|------|-------------|------|
| 1 | 2001206 | 1 | 72 | m04613 | 2 |
| 2 | 3009637 | 1 | 74 | m03926 | 2 |
| 3 | 3003787 | 1 | 75 | m03681 | 3 |
| 4 | 4003744 | 2 | 76 | m14008 | 2 |
| 5 | 4008049 | 1 | 86 | m03775 | 5 |
| 6 | 4014570 | 1 | 88 | m04301 | 8 |
| 10 | 8000647-40207 | 1 | 90 | m02533 | 1 |
| 11 | 4012205 | 1 | 101 | m03866 | 1 |
| 13 | 3012460 | 1 | 102 | 4013139 | 2 |
| 15 | 4019191 | 1 | 110 | m10451 | 1 |
| 17 | 4008679 | 1 | 115 | m03959 | 1 |
| 30 | m10454 | 1 | | | |

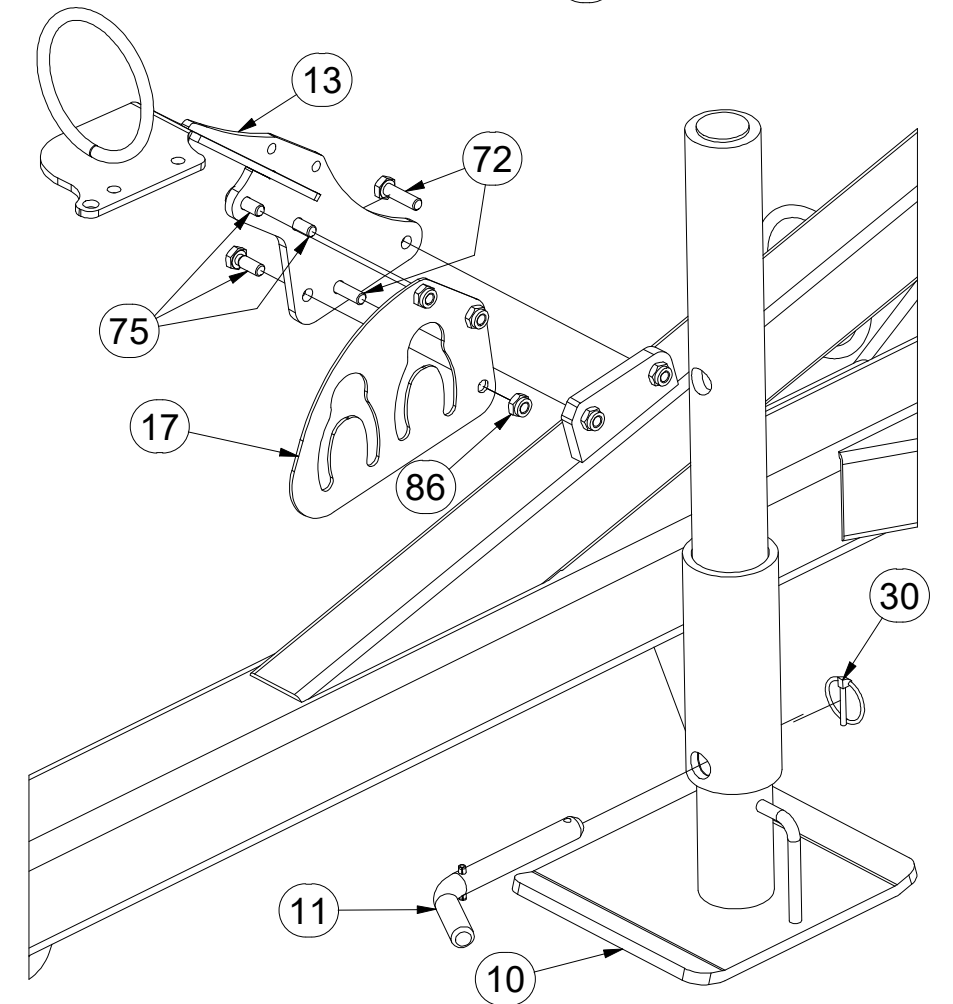
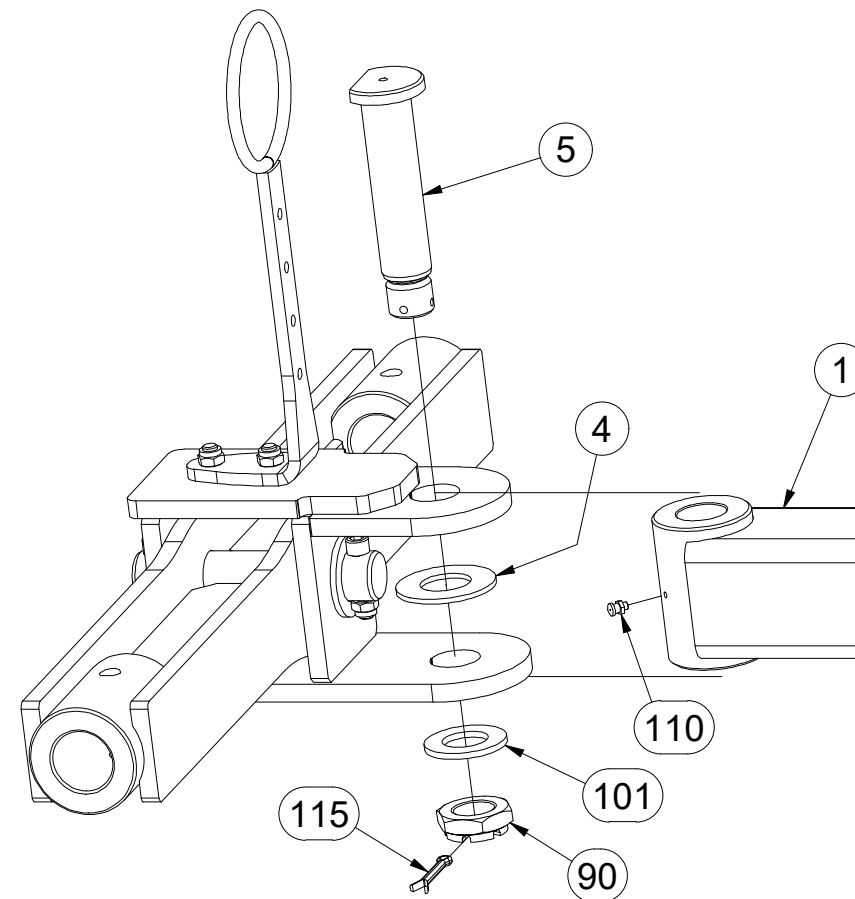
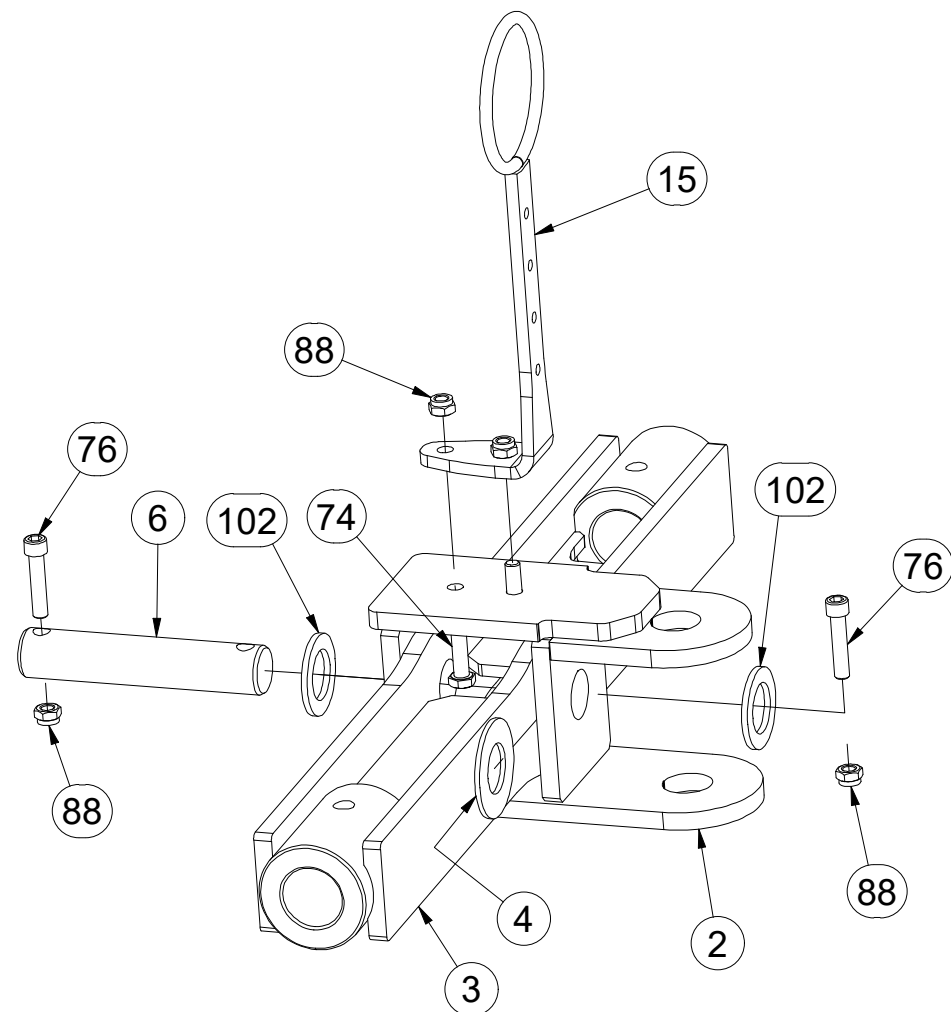
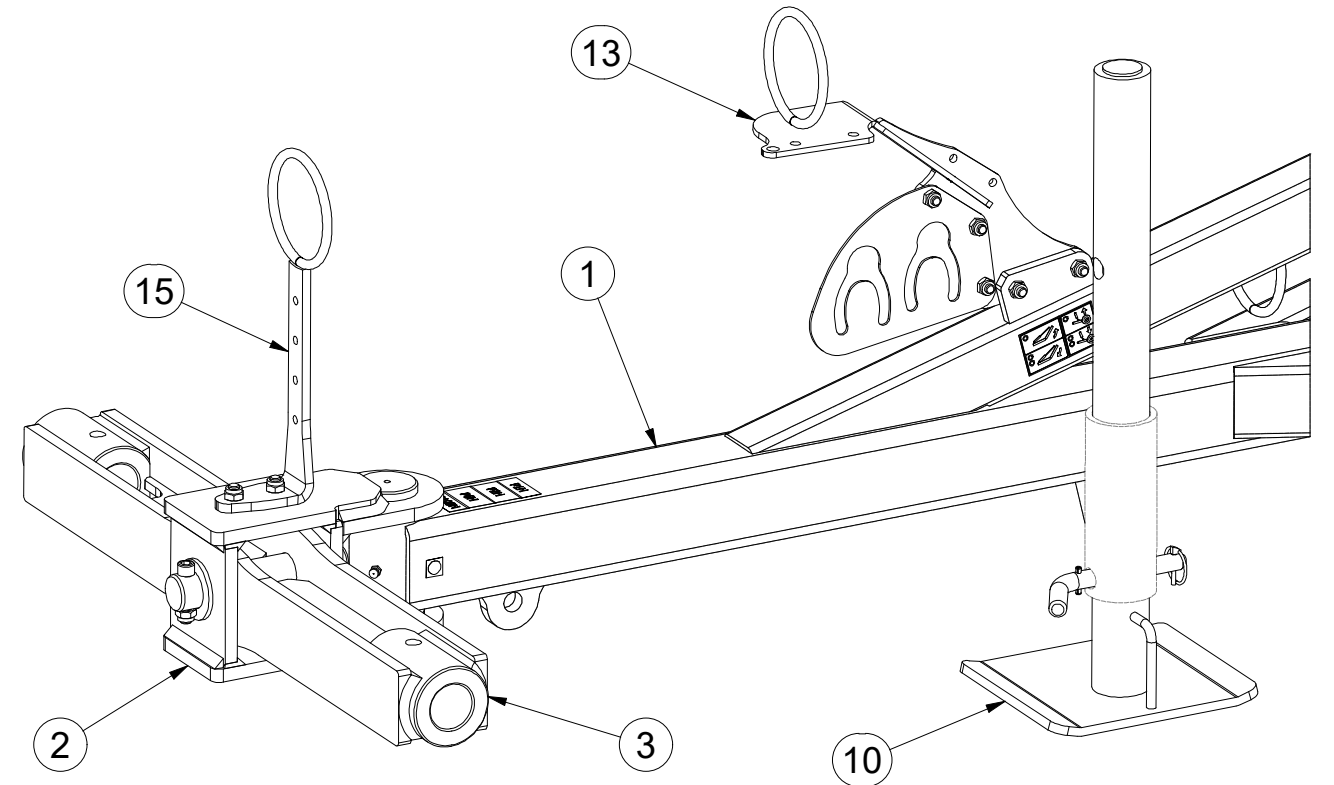

Ⓒ CZ OJ T3

Ⓓ DEICHSEL T3

Ⓕ TIMON T3

Ⓖ GB TOW BAR T3

Ⓔ RU ДЫШЛО T3

Ⓗ PL DYSZEL T3



3012414

| Pos. | Part Number | Pcs. | Pos. | Part Number | Pcs. |
|------|-------------|------|------|-------------|------|
| 1 | 2001206 | 1 | 73 | m04039 | 4 |
| 7 | 4019255 | 2 | 77 | m02254 | 4 |
| 8 | VZ00024252 | 1 | 78 | m17098 | 2 |
| 9 | VZ00024253 | 1 | 85 | m05560 | 4 |
| 12 | m12296 | 1 | 87 | m04503 | 3 |
| 14 | 4013461 | 1 | 88 | m04301 | 8 |
| 31 | m15900 | 1 | 89 | m01306 | 4 |
| 50 | m02579 | 2 | 100 | m07936 | 3 |
| 70 | m01074 | 2 | 103 | m16612 | 4 |
| 71 | m01092 | 3 | | | |

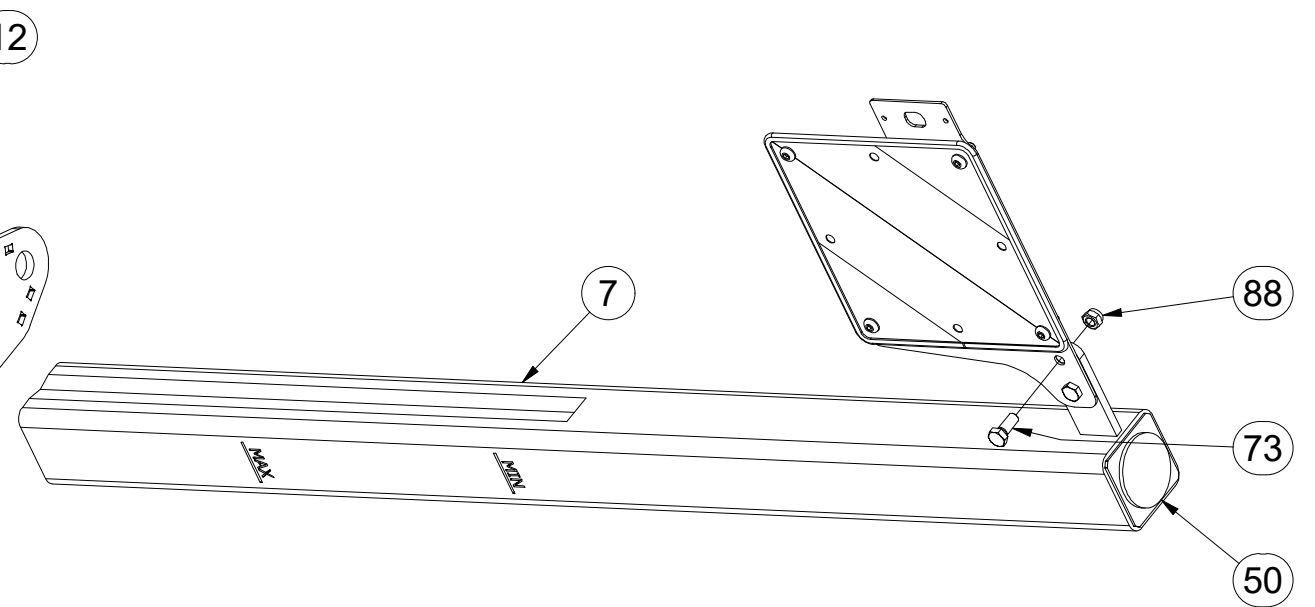
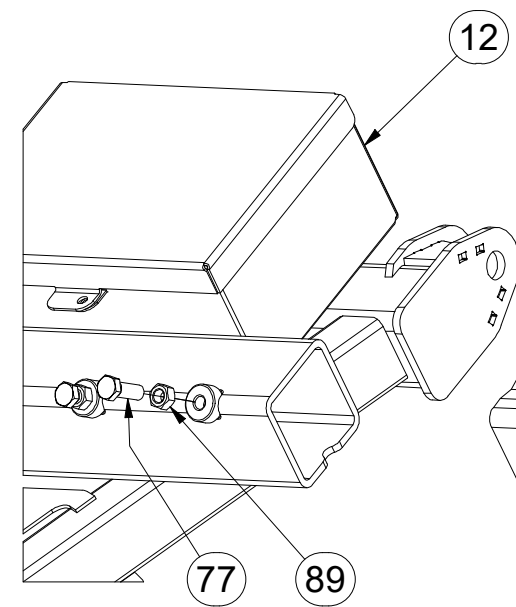
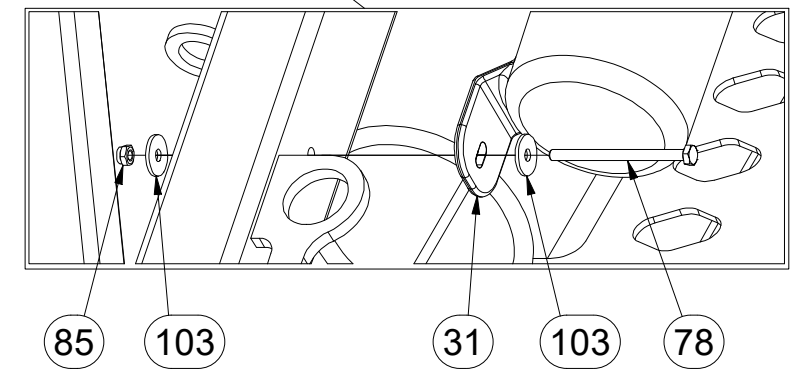
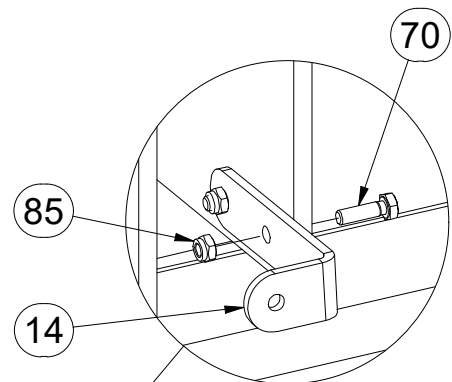
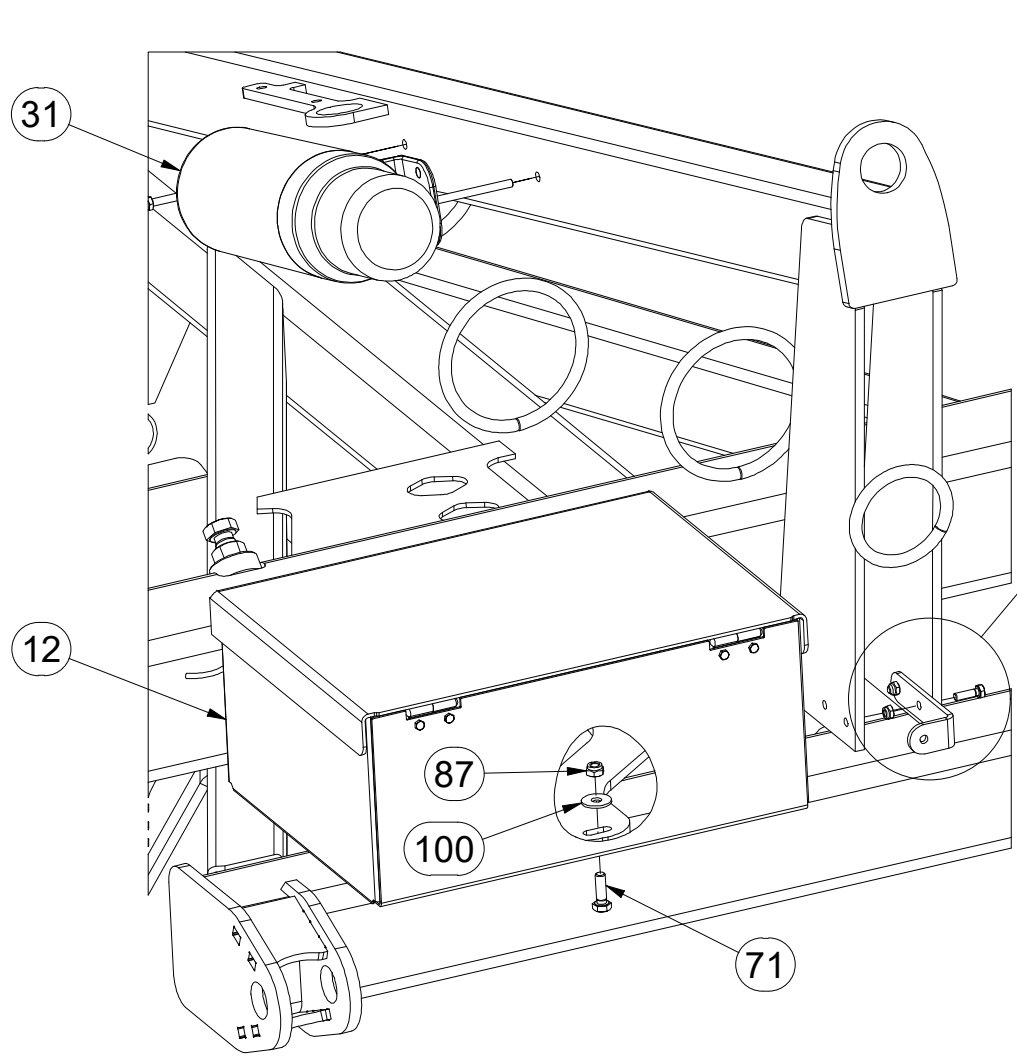
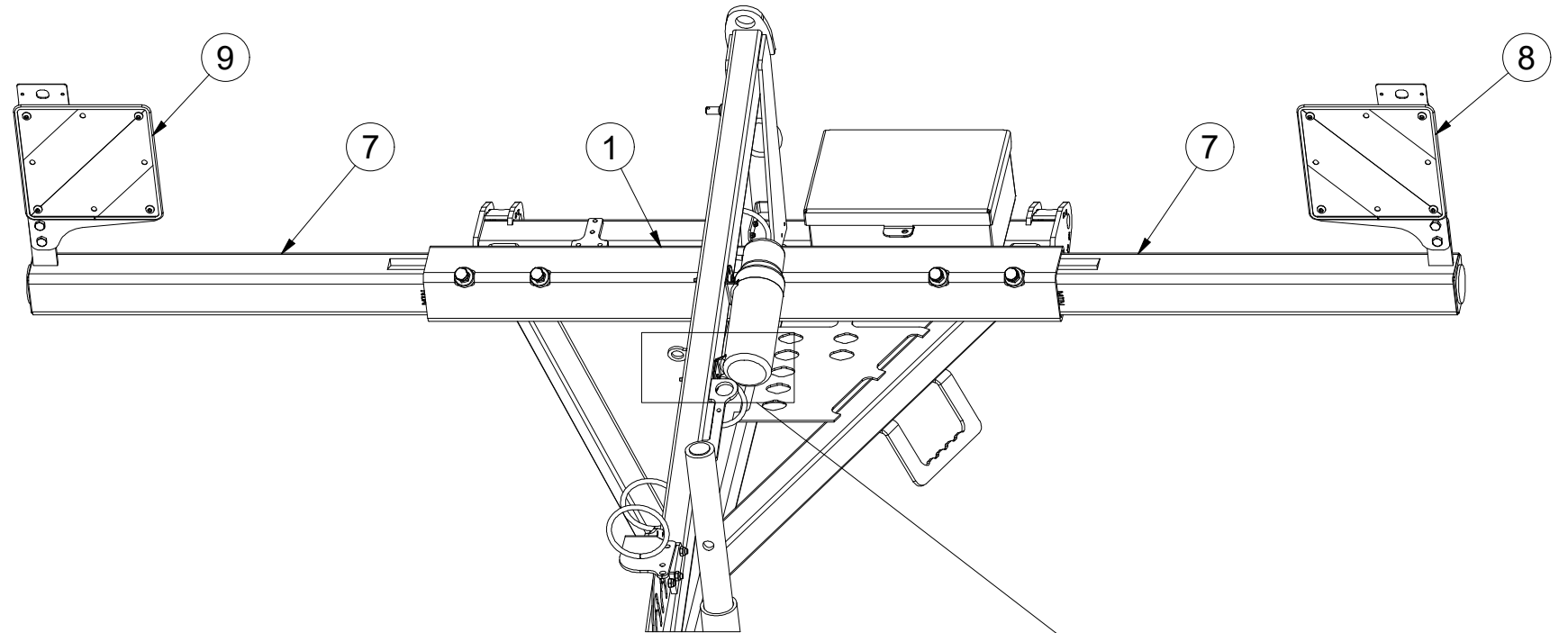

Ⓒ CZ OJ T3

Ⓓ DEICHSEL T3

Ⓕ TIMON T3

m18866

Ⓖ GB TOW BAR T3

Ⓡ RU ДЫШЛО T3

Ⓟ PL DYSZEL T3

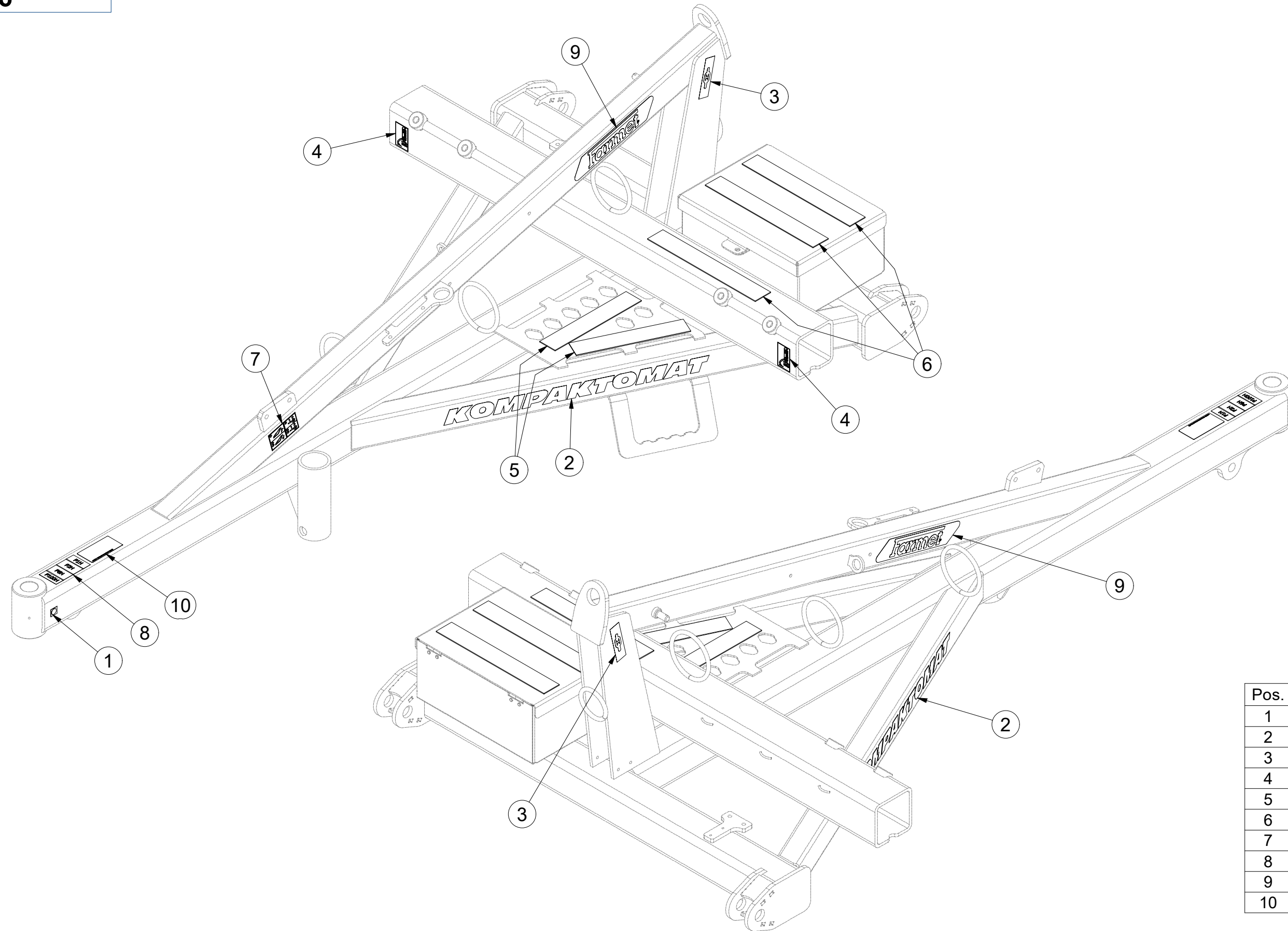

| Pos. | Part Number | Pcs. |
|------|-------------|------|
| 1 | m03320 | 1 |
| 2 | m07688 | 2 |
| 3 | m03316 | 2 |
| 4 | m10180 | 2 |
| 5 | m11147 | 2 |
| 6 | m11146 | 3 |
| 7 | m11291 | 1 |
| 8 | m11295 | 1 |
| 9 | m13116 | 2 |
| 10 | m13708 | 1 |

☞ SADA ČEPŮ TBZ 3

☞ BOLZENSATZ TBZ 3

☞ KIT D'EMBOUITS TBZ 3

3011605

☞ SET OF TBZ 3 PINS

☞ КОМПЛЕКТ ПАЛЬЦЕВ TBZ 3

☞ ZESTAW CZOPÓW TBZ 3

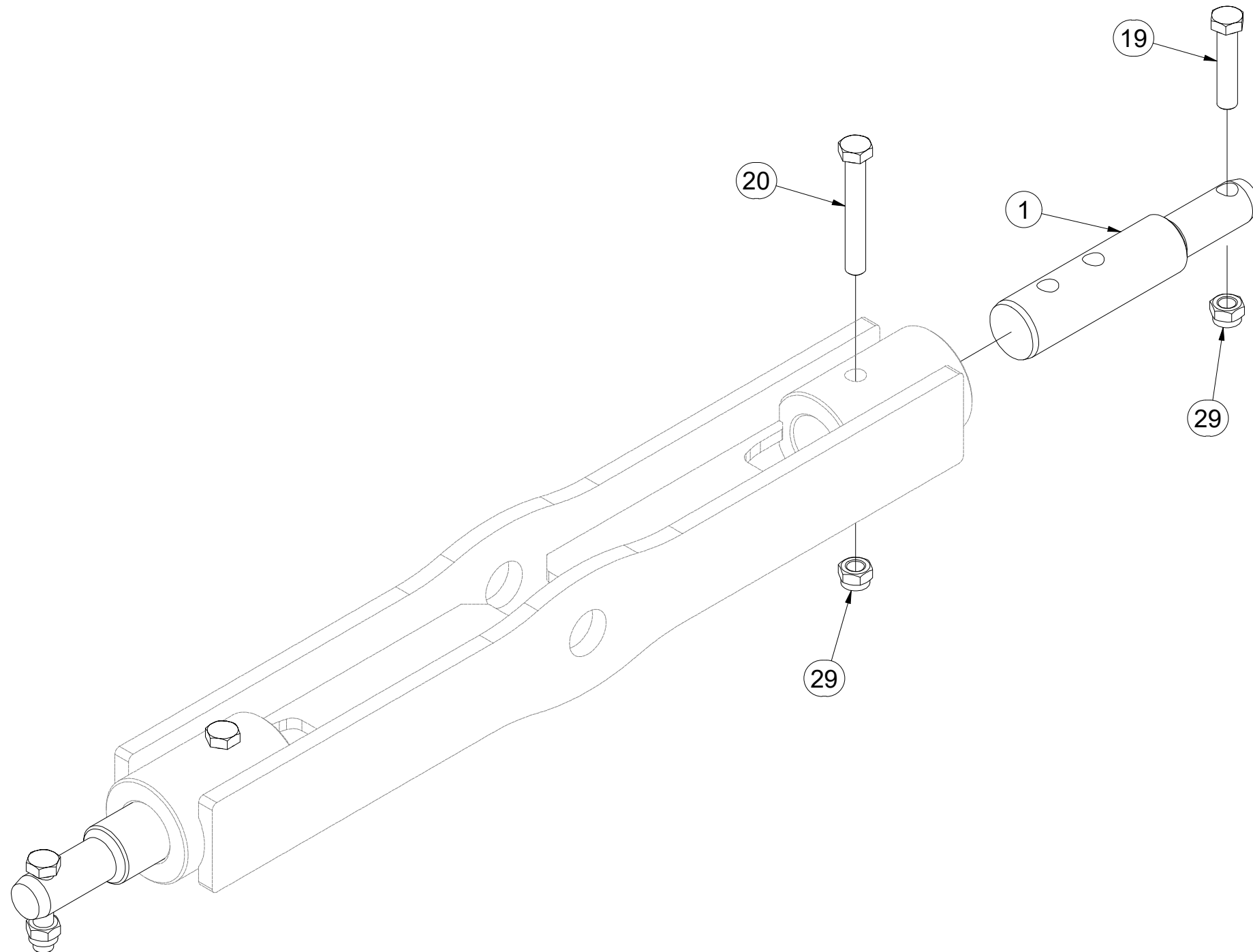
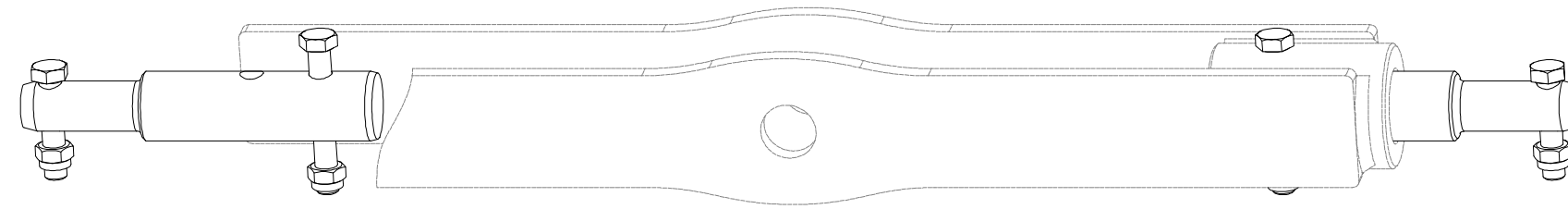

| Pos. | Part Number | Pcs. |
|------|-------------|------|
| 1 | VZ00022884 | 2 |
| 19 | m01133 | 2 |
| 20 | m02970 | 2 |
| 29 | m03683 | 4 |

ⒸZ TERČ PŘEDNÍ LEVÝ

Ⓓ SCHILD, VORDERES, LINKES

Ⓕ CIBLE AVANT GAUCHE

ⒸB LEFT FRONT DISC

ⒶЩИТОК ПЕРЕДНИЙ ЛЕВЫЙ

Ⓐ TARCZA PRZEDNIA LEWA



VZ00024252

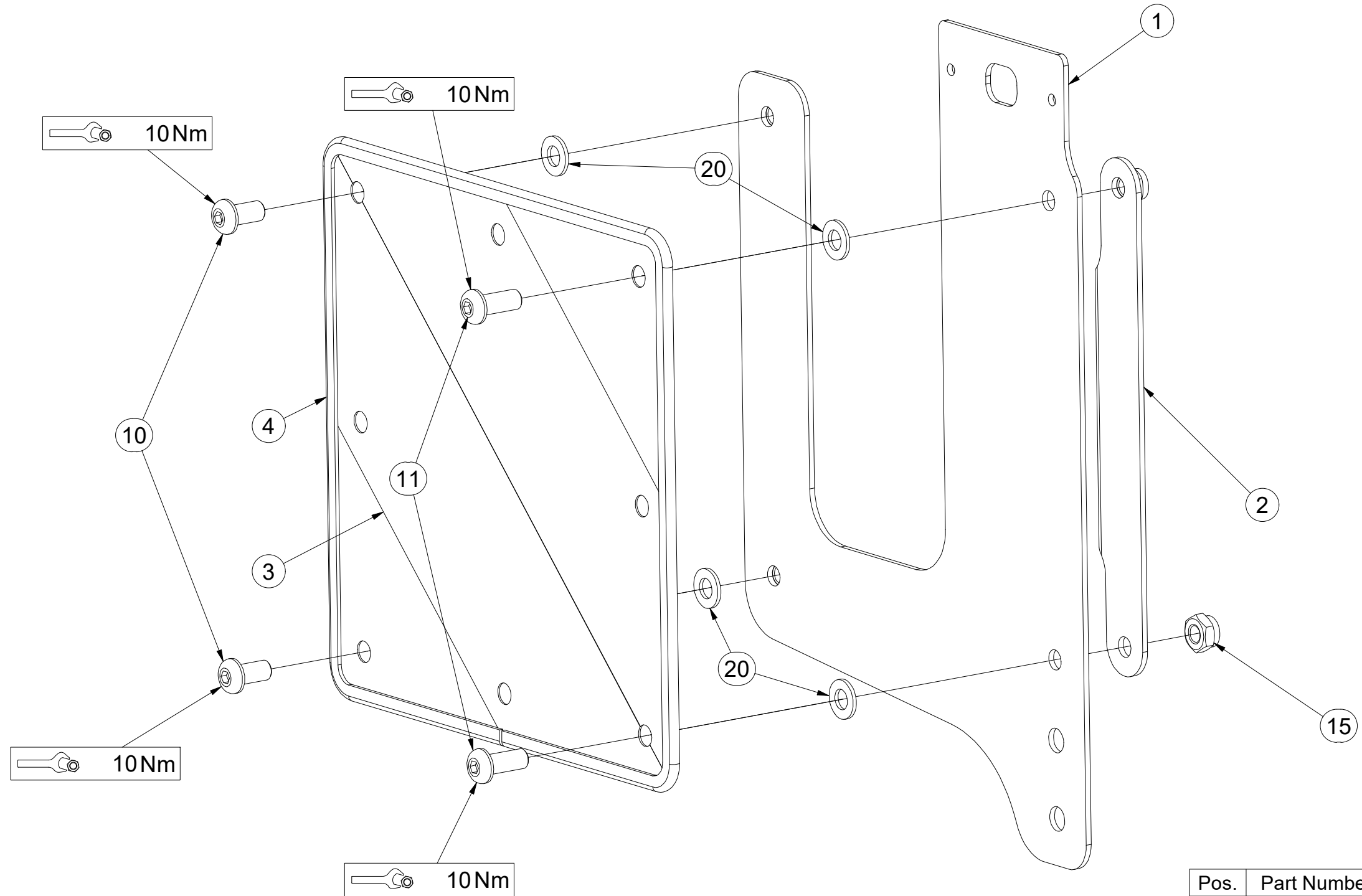
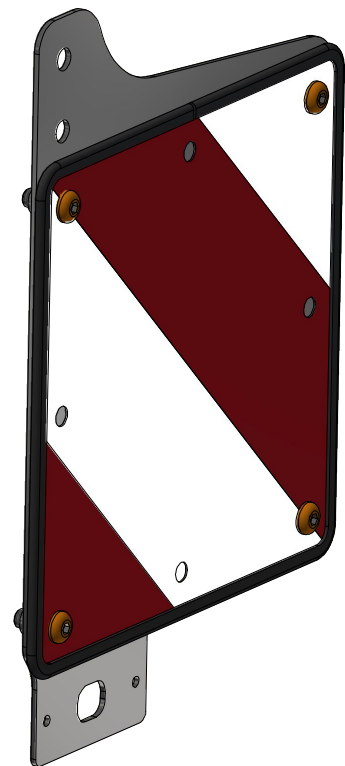

| Pos. | Part Number | Pcs. |
|------|-------------|------|
| 1 | VZ00024254 | 1 |
| 2 | VZ00024261 | 1 |
| 3 | m18855 | 1 |
| 4 | 9005707 | 1 |
| 10 | m16637 | 2 |
| 11 | m16688 | 2 |
| 15 | m03775 | 4 |
| 20 | m01209 | 4 |

ⒸZ TERČ PŘEDNÍ PRAVÝ

Ⓓ SCHILD, VORDERES, RECHTES

Ⓕ CIBLE AVANT DROITE

ⒸB RIGHT FRONT DISC

ⒸU ЩИТОК ПЕРЕДНИЙ ПРАВЫЙ

ⒸL TARCZA PRZEDNIA PRAWA



VZ00024253

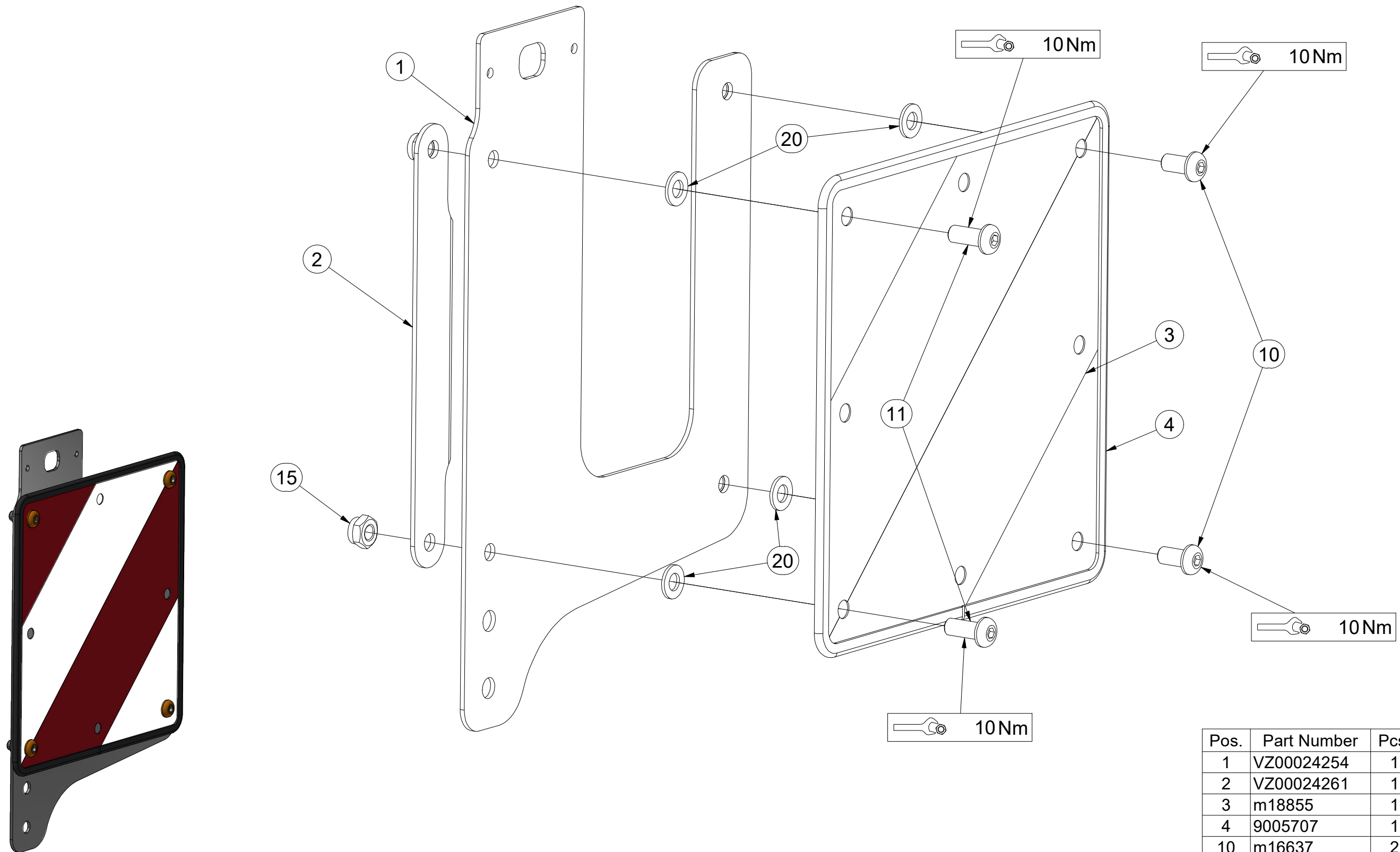

| Pos. | Part Number | Pcs. |
|------|-------------|------|
| 1 | VZ00024254 | 1 |
| 2 | VZ00024261 | 1 |
| 3 | m18855 | 1 |
| 4 | 9005707 | 1 |
| 10 | m16637 | 2 |
| 11 | m16688 | 2 |
| 15 | m03775 | 4 |
| 20 | m01209 | 4 |

Ⓒ SADA KYPŘIČŮ STOP

Ⓓ SPURENLOCKERERSATZ

Ⓕ KIT DE CULTIVATEURS DE TRACES

3005535

Ⓖ SET OF TRACK CULTIVATORS

Ⓡ КОМПЛЕКТ РЫХЛИТЕЛЕЙ КОЛЕИ

Ⓟ ZESTAW SPULCHNIACZY ŚLADÓW

Farmet

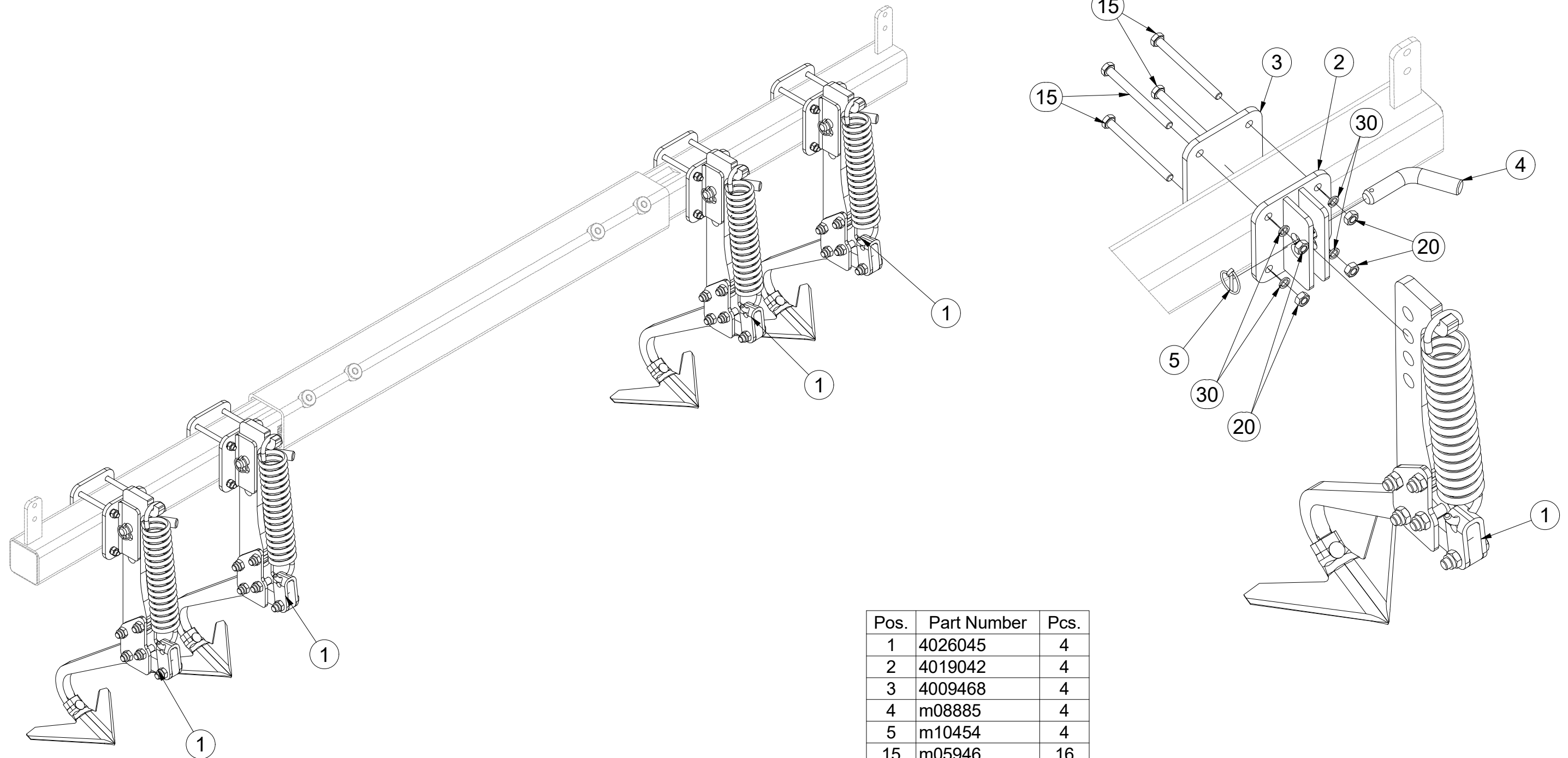

| Pos. | Part Number | Pcs. |
|------|-------------|------|
| 1 | 4026045 | 4 |
| 2 | 4019042 | 4 |
| 3 | 4009468 | 4 |
| 4 | m08885 | 4 |
| 5 | m10454 | 4 |
| 15 | m05946 | 16 |
| 20 | m01305 | 16 |
| 30 | m03988 | 16 |

Ⓒ KYPŘIČ STOP

Ⓓ SPURENLOCKERER

Ⓕ CULTIVATEUR DES TRACES

Ⓖ TRACK CULTIVATOR

Ⓡ РЫХЛИТЕЛЬ КОЛЕИ

Ⓟ SPULCHNIARKA STÓP

Farmet

4026045

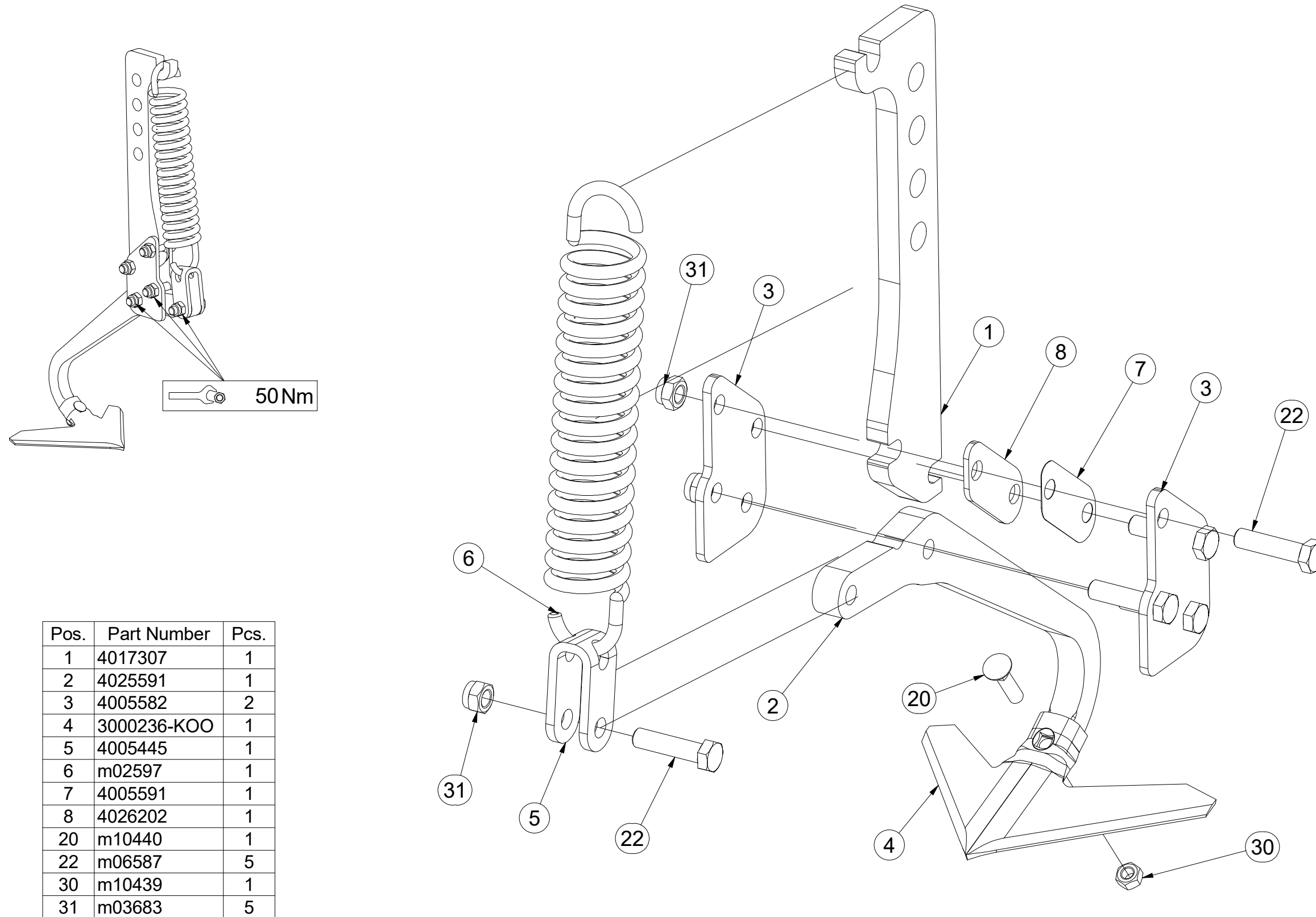

| Pos. | Part Number | Pcs. |
|------|-------------|------|
| 1 | 4017307 | 1 |
| 2 | 4025591 | 1 |
| 3 | 4005582 | 2 |
| 4 | 3000236-KOO | 1 |
| 5 | 4005445 | 1 |
| 6 | m02597 | 1 |
| 7 | 4005591 | 1 |
| 8 | 4026202 | 1 |
| 20 | m10440 | 1 |
| 22 | m06587 | 5 |
| 30 | m10439 | 1 |
| 31 | m03683 | 5 |

ⒸZ SADA PŘEDNÍCH SMYKŮ

Ⓓ SATZ VORDERE ACKERSCHLEPPEN

Ⓕ KIT DE NIVELEURS AVANT

ⒼB SET OF FRONT LEVELLING BARS

ⒺU КОМПЛЕКТ ПЕРЕДНИХ БОРОН

ⒼL ZESTAW PRZEDNICH WŁÓK

Farmet

3006506

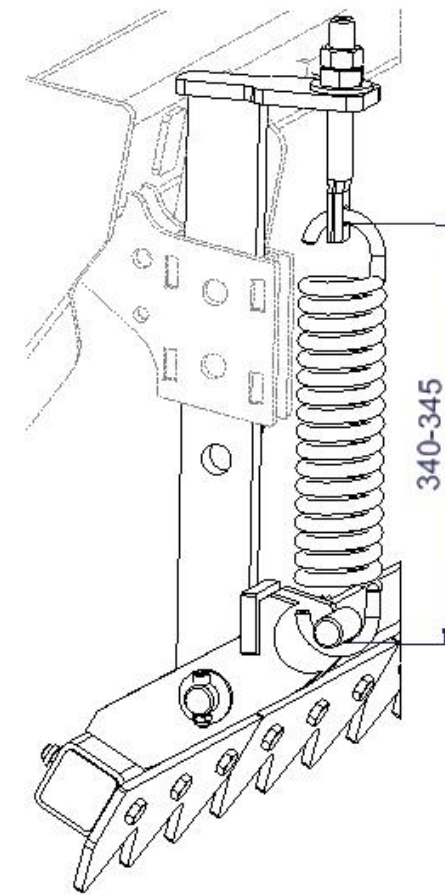
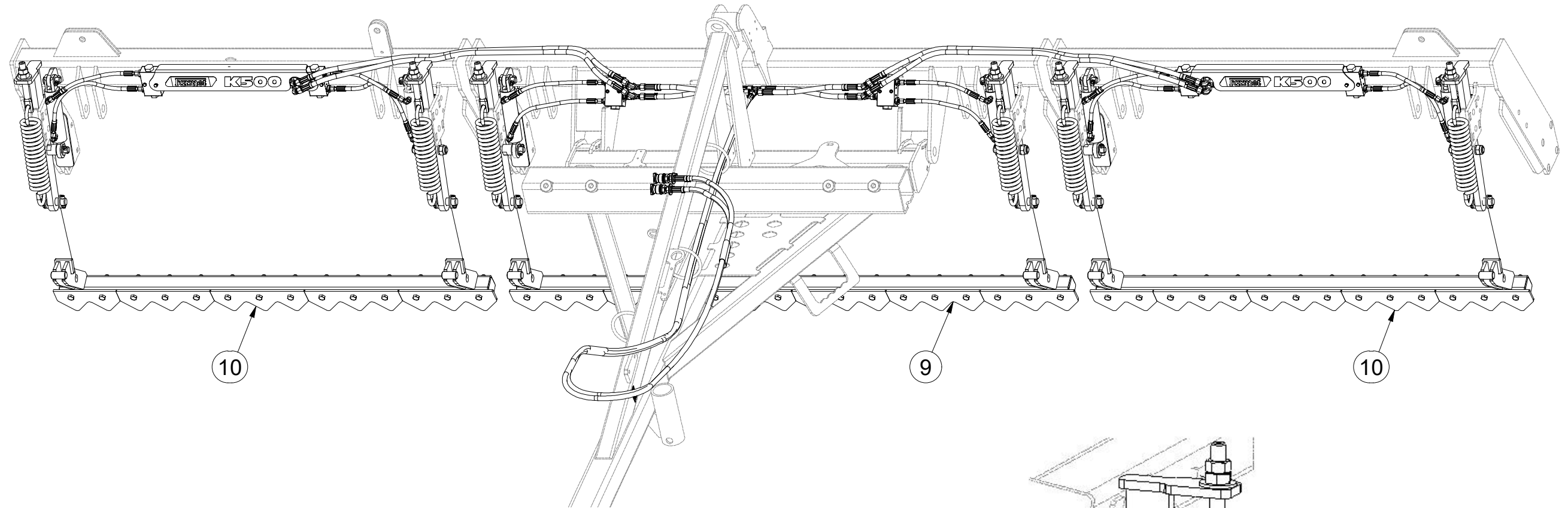

| Pos. | Part Number | Pcs. |
|------|-------------|------|
| 9 | 3010749 | 1 |
| 10 | 3011432 | 2 |

Ⓒ SADA PŘEDNÍCH SMYKŮ

Ⓓ SATZ VORDERE ACKERSCHLEPPEN

Ⓕ KIT DE NIVELEURS AVANT

Ⓖ SET OF FRONT LEVELLING BARS

Ⓡ КОМПЛЕКТ ПЕРЕДНИХ БОРОН

Ⓟ ZESTAW PRZEDNICH WŁÓK



3006506

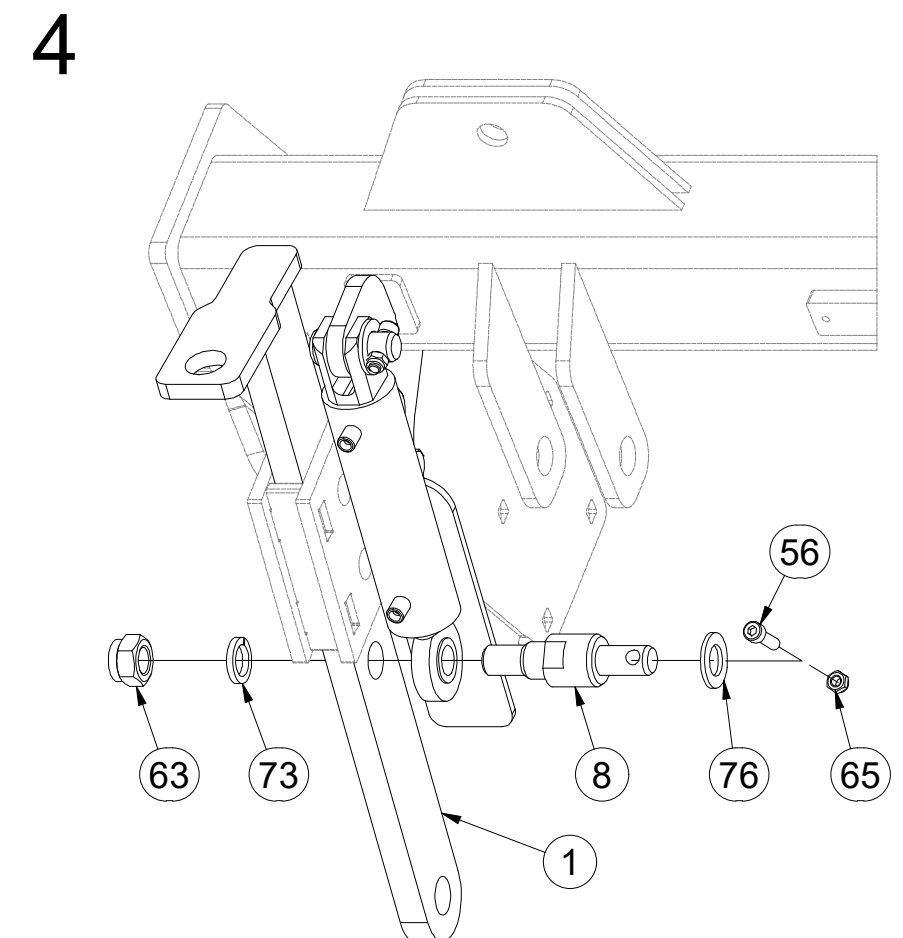
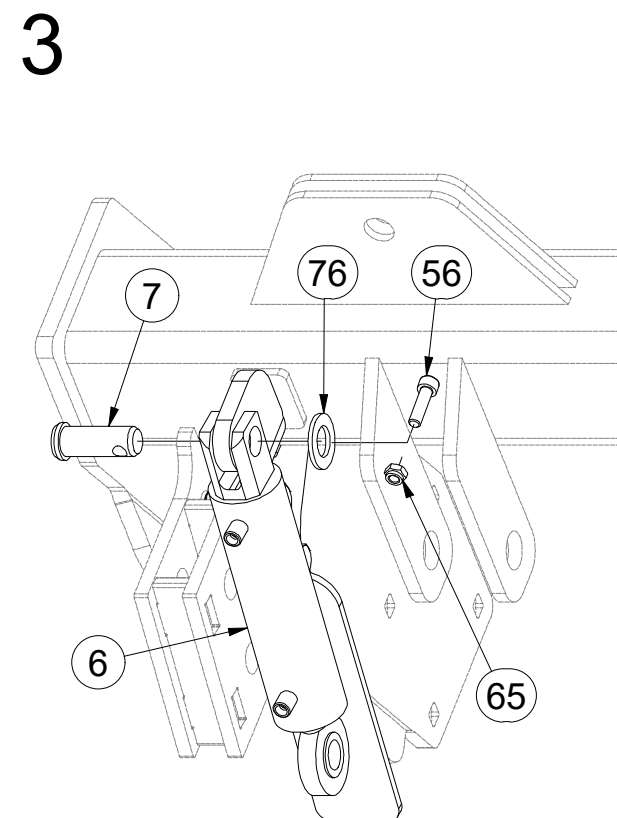
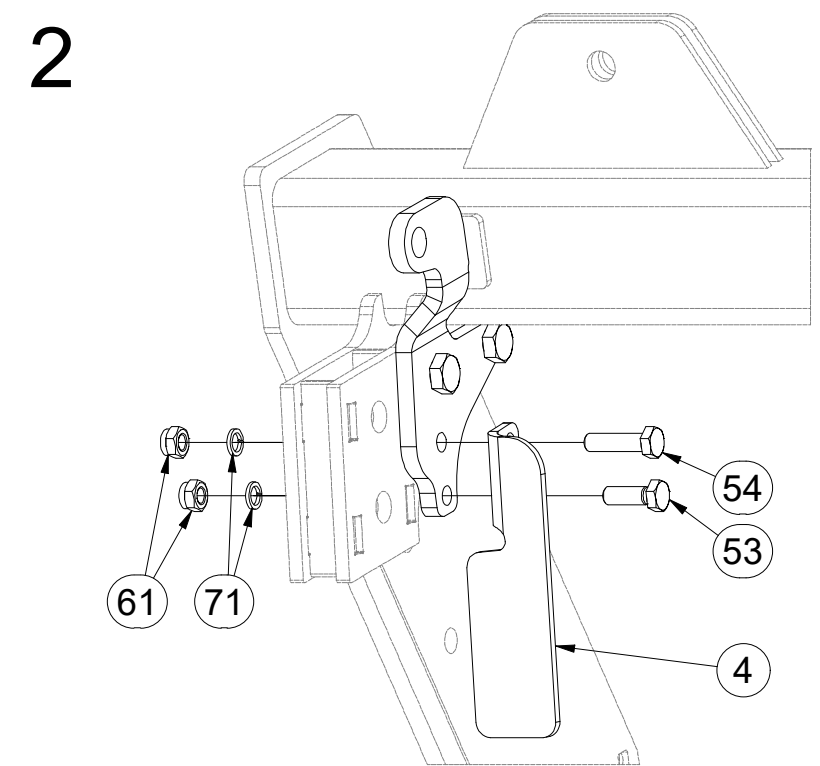
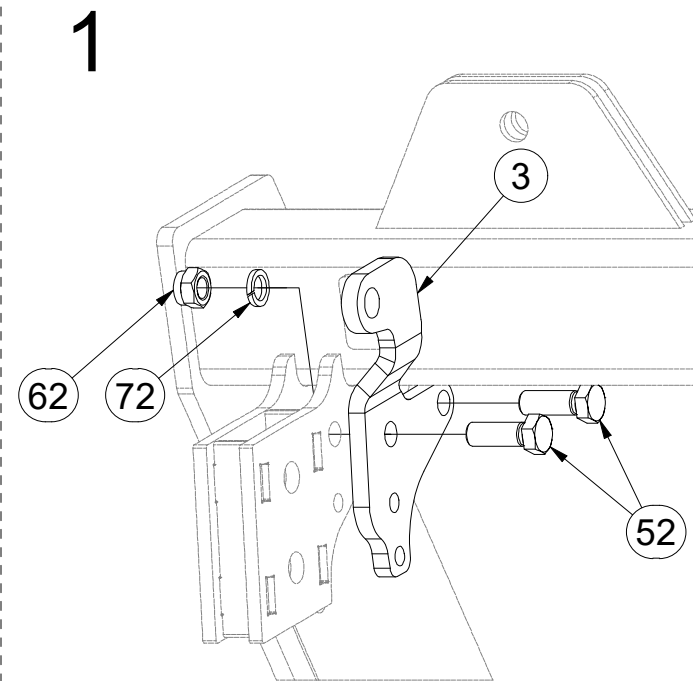
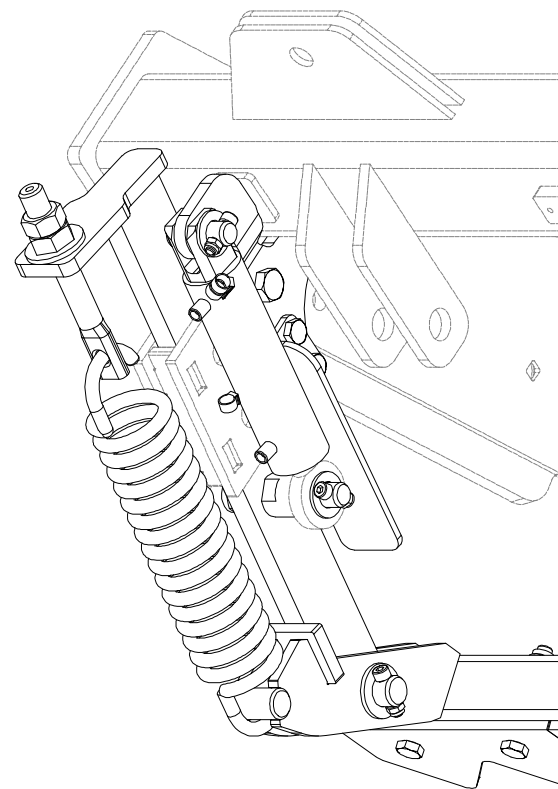

| Pos. | Part Number | Pcs. | Pos. | Part Number | Pcs. |
|------|-------------|------|------|-------------|------|
| 1 | 3008688 | 6 | 56 | m09870 | 12 |
| 3 | 4010386 | 3 | 61 | m04301 | 12 |
| 4 | 4010388 | 3 | 62 | m03683 | 12 |
| 6 | VZ00012974 | 6 | 63 | m05648 | 6 |
| 7 | 4015710 | 6 | 65 | m04503 | 24 |
| 8 | VZ00023103 | 6 | 71 | m03988 | 12 |
| 52 | m02254 | 12 | 72 | m02157 | 12 |
| 53 | m04343 | 6 | 73 | m01229 | 6 |
| 54 | m06077 | 6 | 76 | m03768 | 12 |

ⒸZ SADA PŘEDNÍCH SMYKŮ

Ⓓ SATZ VORDERE ACKERSCHLEPPEN

Ⓕ KIT DE NIVELEURS AVANT

3006506

ⒼB SET OF FRONT LEVELLING BARS

ⒺU КОМПЛЕКТ ПЕРЕДНИХ БОРОН

ⒽL ZESTAW PRZEDNICH WŁÓK

Farmet

5

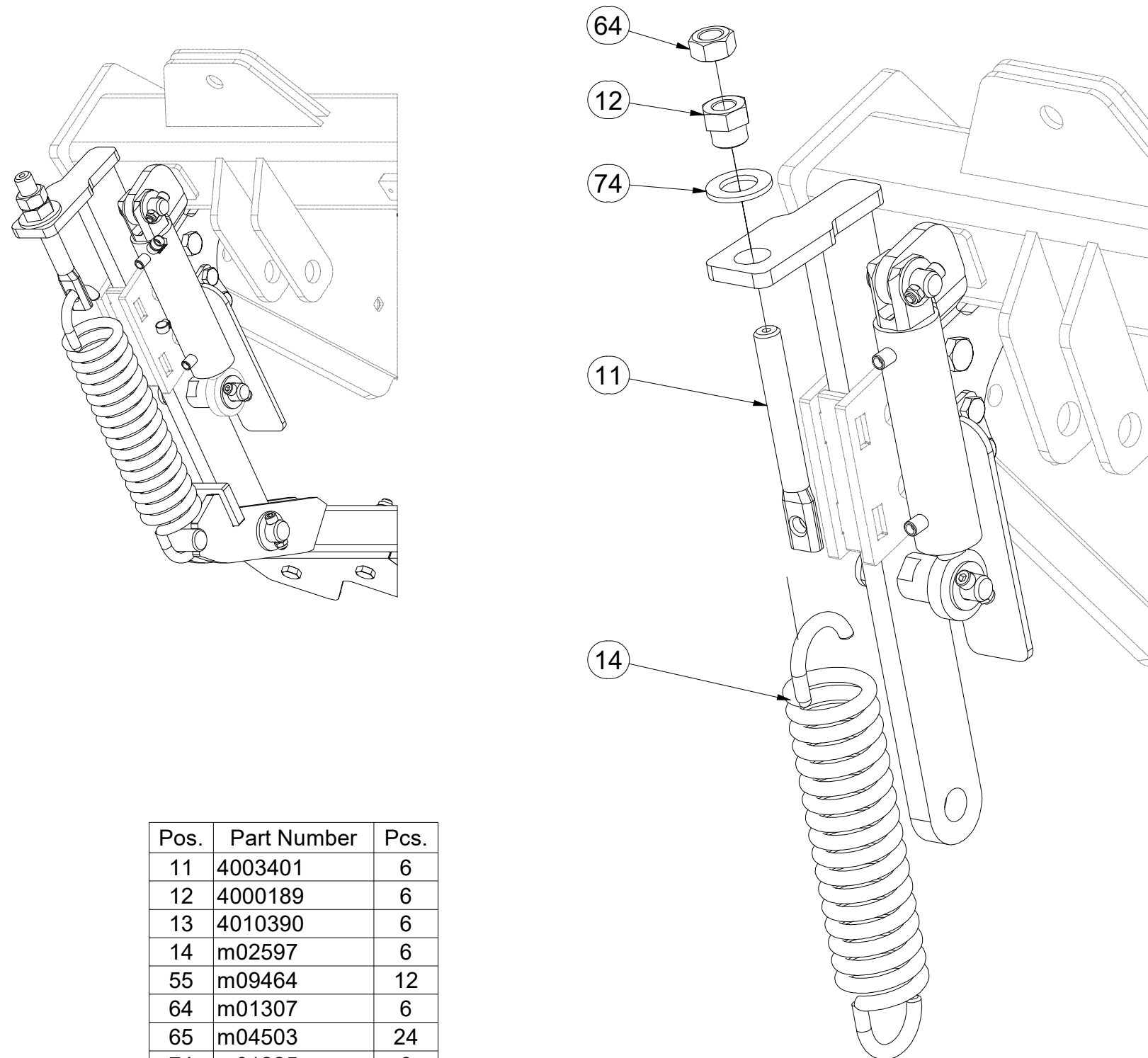

| Pos. | Part Number | Pcs. |
|------|-------------|------|
| 11 | 4003401 | 6 |
| 12 | 4000189 | 6 |
| 13 | 4010390 | 6 |
| 14 | m02597 | 6 |
| 55 | m09464 | 12 |
| 64 | m01307 | 6 |
| 65 | m04503 | 24 |
| 74 | m01225 | 6 |
| 75 | m14028 | 12 |

6

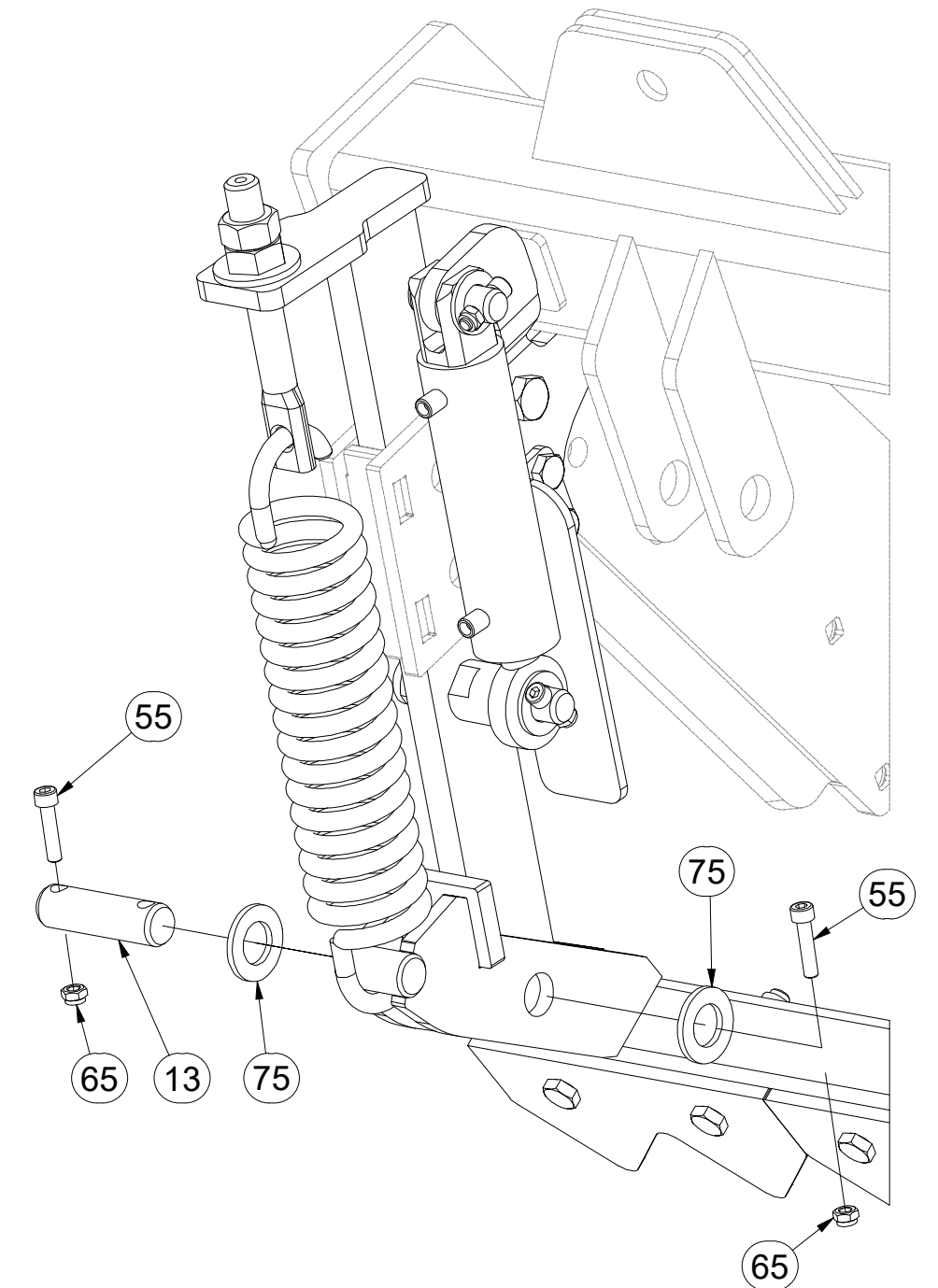

ⒸZ SADA PŘEDNÍCH SMYKŮ

Ⓓ SATZ VORDERE ACKERSCHLEPPEN

Ⓕ KIT DE NIVELEURS AVANT

ⒼB SET OF FRONT LEVELLING BARS

ⒶR КОМПЛЕКТ ПЕРЕДНИХ БОРОН

ⒶL ZESTAW PRZEDNICH WŁÓK



3006506

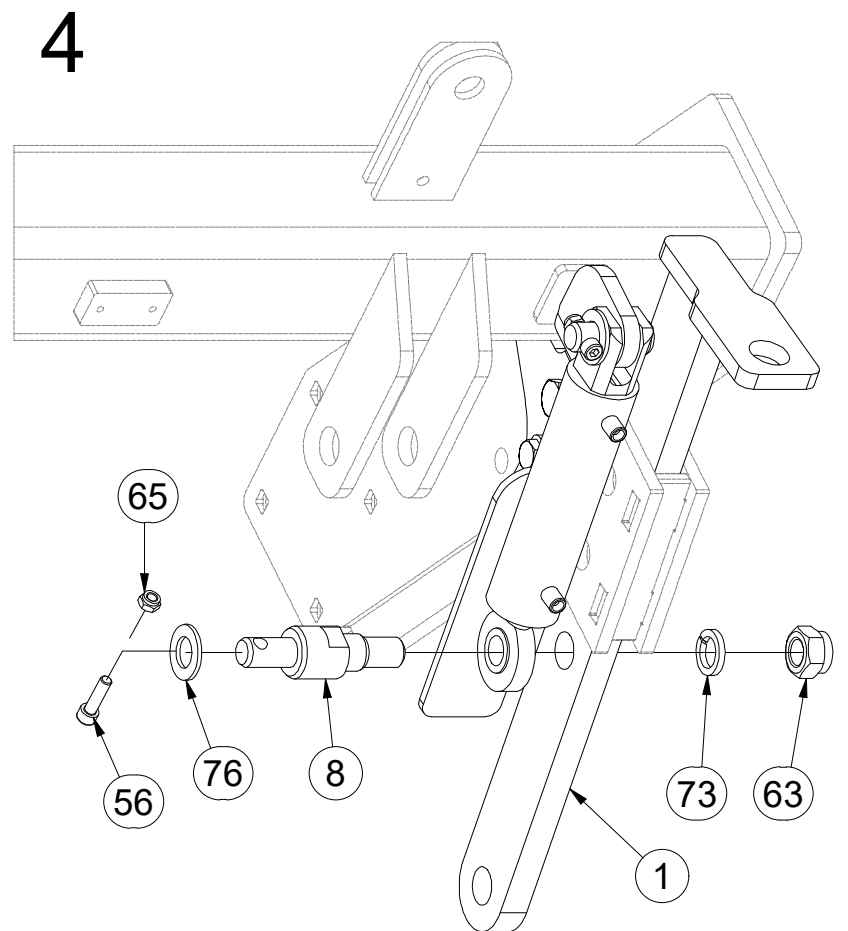
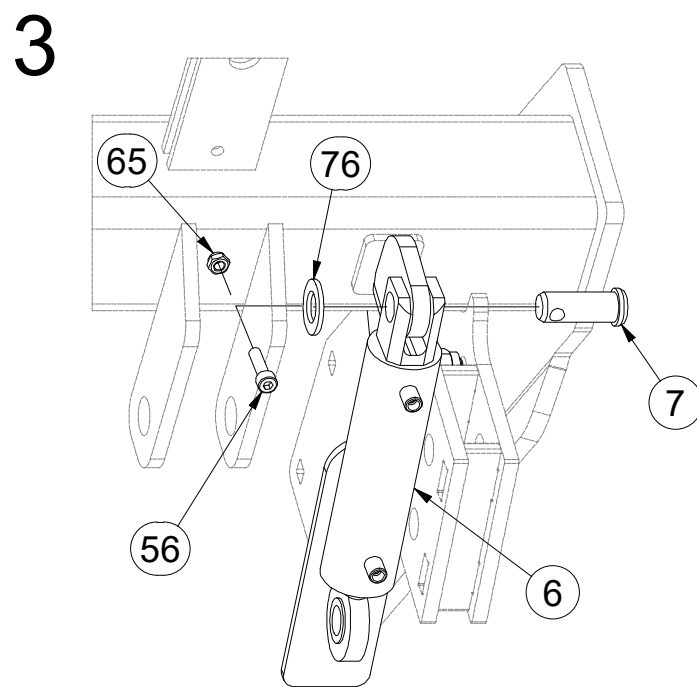
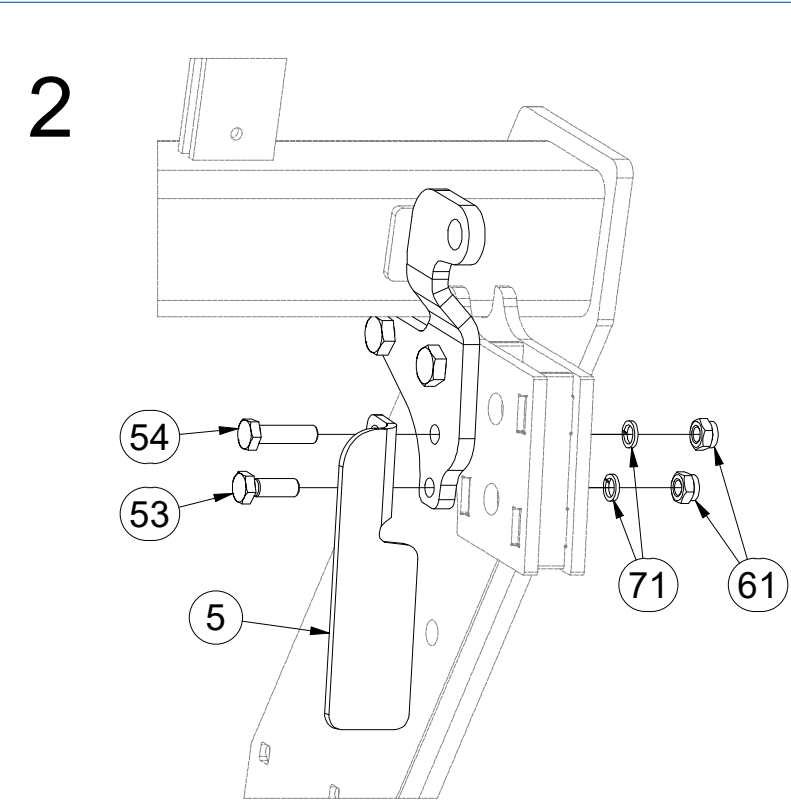
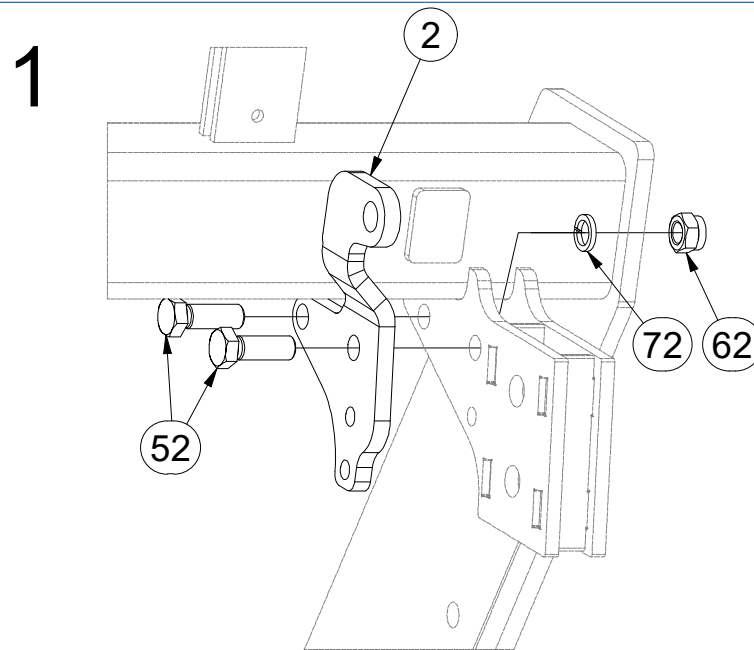
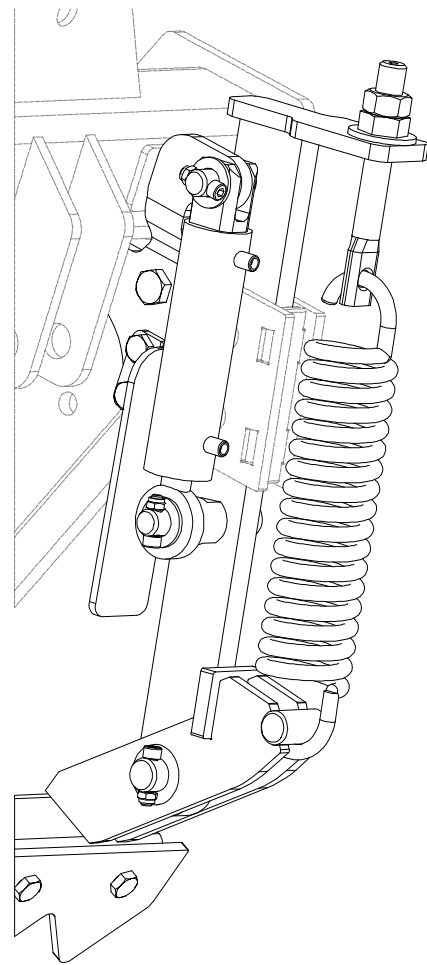

| Pos. | Part Number | Pcs. | Pos. | Part Number | Pcs. |
|------|-------------|------|------|-------------|------|
| 1 | 3008688 | 6 | 56 | m09870 | 12 |
| 2 | 4010387 | 3 | 61 | m04301 | 12 |
| 5 | 4010389 | 3 | 62 | m03683 | 12 |
| 6 | VZ00012974 | 6 | 63 | m05648 | 6 |
| 7 | 4015710 | 6 | 65 | m04503 | 24 |
| 8 | VZ00023103 | 6 | 71 | m03988 | 12 |
| 52 | m02254 | 12 | 72 | m02157 | 12 |
| 53 | m04343 | 6 | 73 | m01229 | 6 |
| 54 | m06077 | 6 | 76 | m03768 | 12 |

ⒸZ SADA PŘEDNÍCH SMYKŮ

Ⓓ SATZ VORDERE ACKERSCHLEPPEN

Ⓕ KIT DE NIVELEURS AVANT

ⒼB SET OF FRONT LEVELLING BARS

ⒺU КОМПЛЕКТ ПЕРЕДНИХ БОРОН

ⒶL ZESTAW PRZEDNICH WŁÓK



3006506

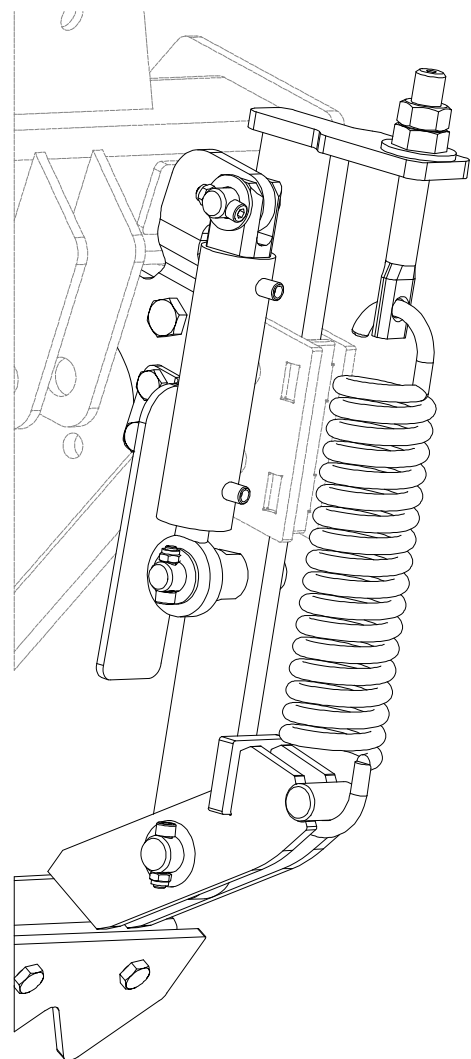

5

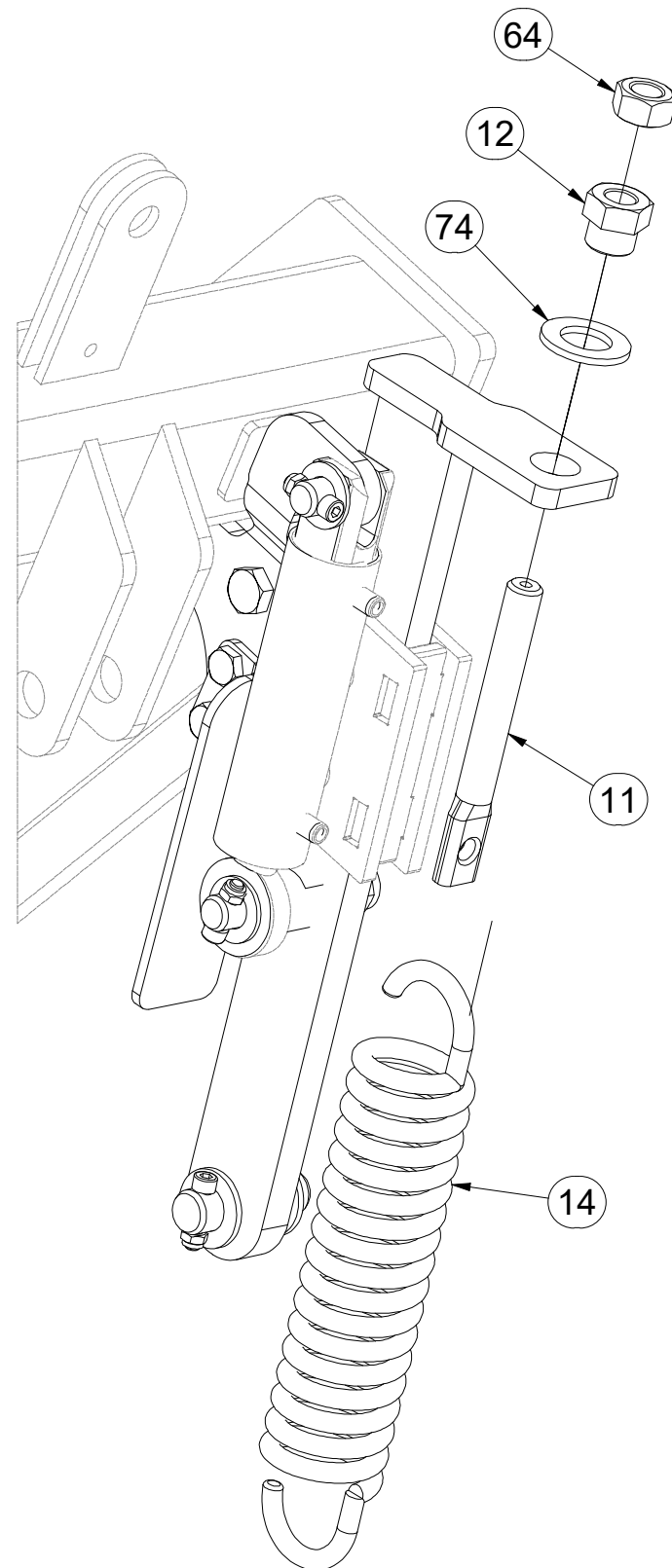

| Pos. | Part Number | Pcs. | Pos. | Part Number | Pcs. |
|------|-------------|------|------|-------------|------|
| 11 | 4003401 | 6 | 64 | m01307 | 6 |
| 12 | 4000189 | 6 | 65 | m04503 | 24 |
| 13 | 4010390 | 6 | 74 | m01225 | 6 |
| 14 | m02597 | 6 | 75 | m14028 | 12 |
| 55 | m09464 | 12 | | | |

6

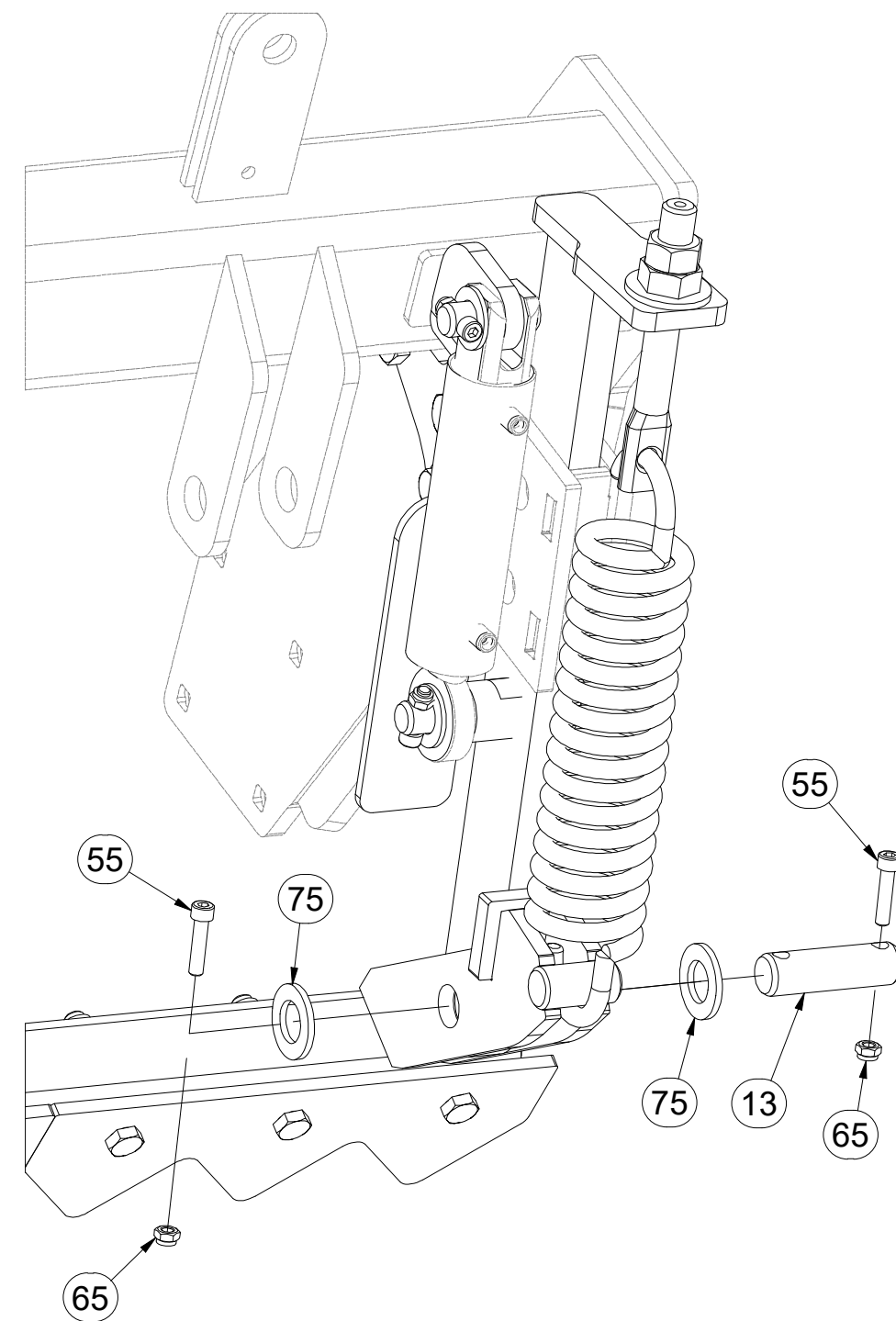

ⒸZ SADA PŘEDNÍCH SMYKŮ

Ⓓ SATZ VORDERE ACKERSCHLEPPEN

Ⓕ KIT DE NIVELEURS AVANT

ⒼB SET OF FRONT LEVELLING BARS

ⒺU КОМПЛЕКТ ПЕРЕДНИХ БОРОН

ⒼL ZESTAW PRZEDNICH WŁÓK



3006506

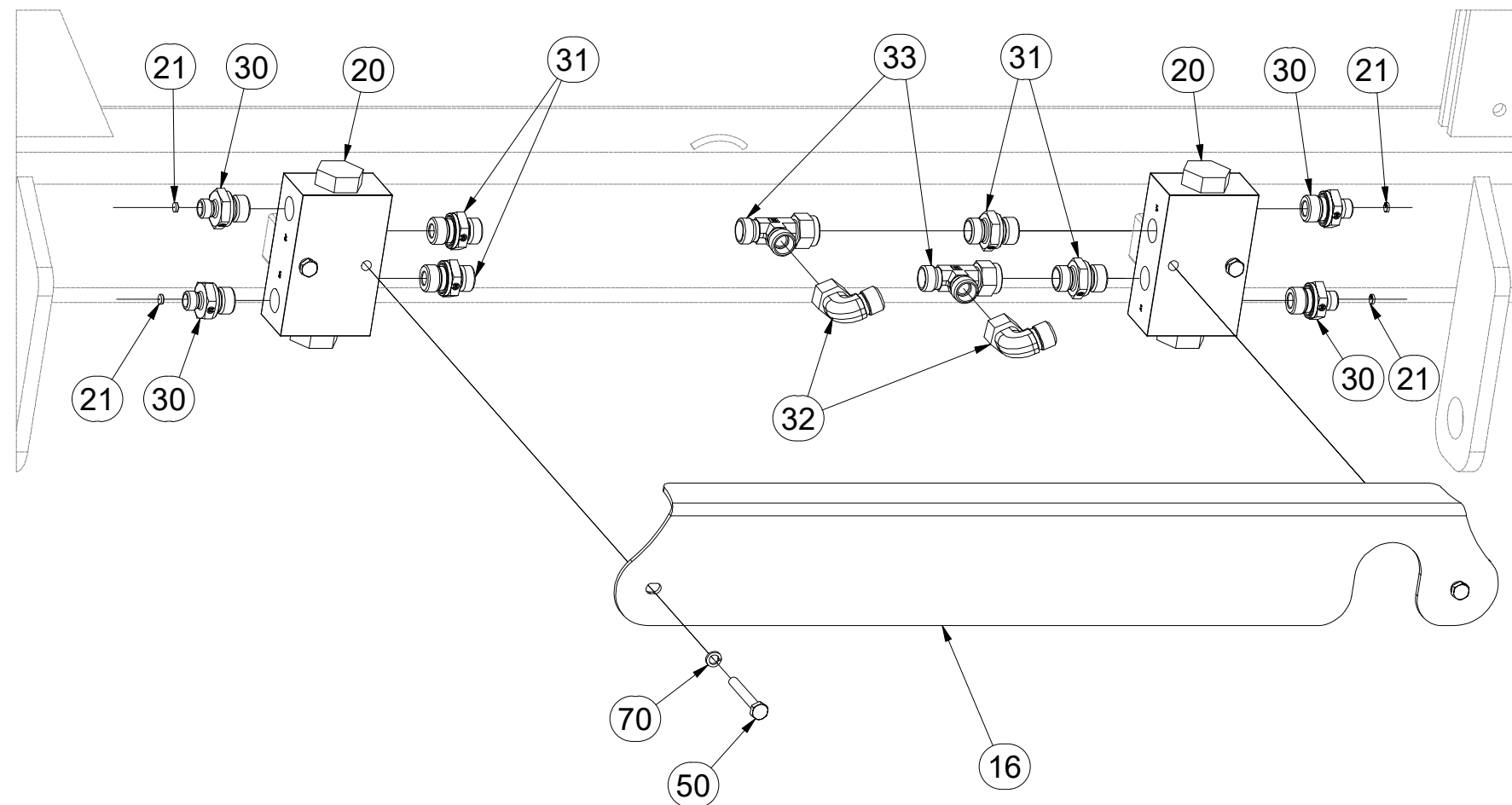
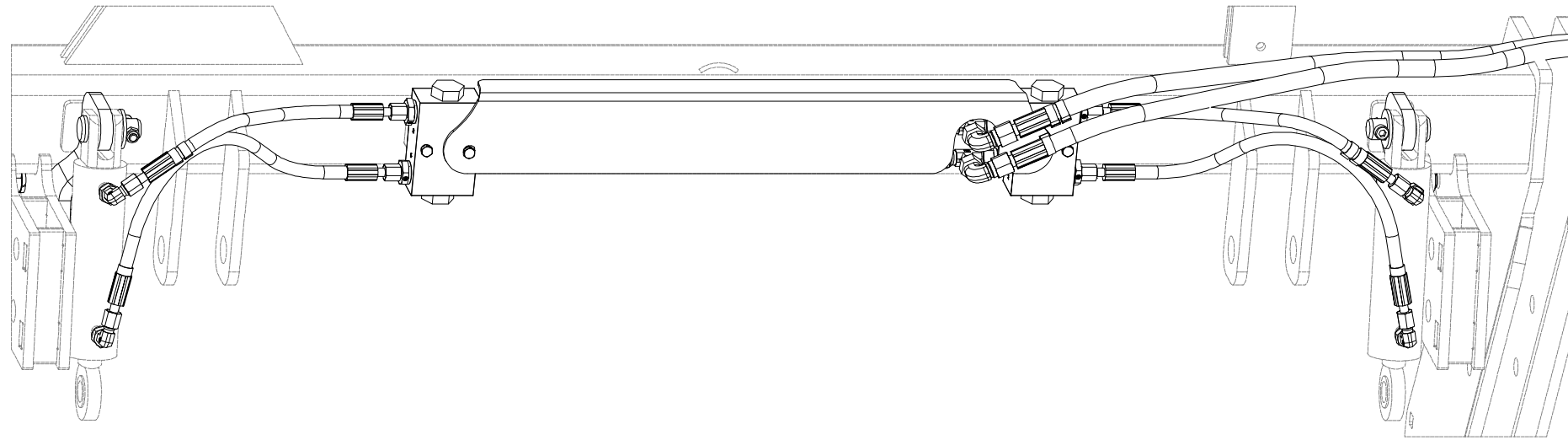
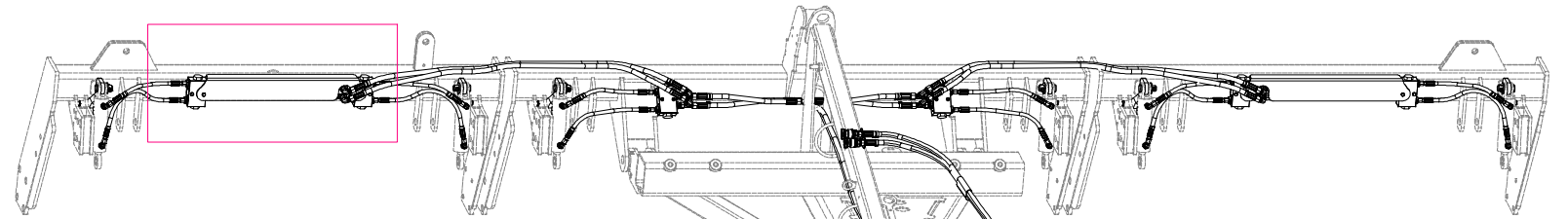

| Pos. | Part Number | Pcs. |
|------|-------------|------|
| 16 | 4018114 | 1 |
| 20 | m09911 | 6 |
| 21 | m12986 | 12 |
| 30 | m12951 | 12 |
| 31 | m06528 | 12 |
| 32 | m06803 | 8 |
| 33 | m07568 | 8 |
| 50 | m05561 | 8 |
| 70 | m01200 | 12 |

ⒸZ SADA PŘEDNÍCH SMYKŮ

Ⓓ SATZ VORDERE ACKERSCHLEPPEN

Ⓕ KIT DE NIVELEURS AVANT

ⒼB SET OF FRONT LEVELLING BARS

ⒺU КОМПЛЕКТ ПЕРЕДНИХ БОРОН

ⒼL ZESTAW PRZEDNICH WŁÓK



3006506

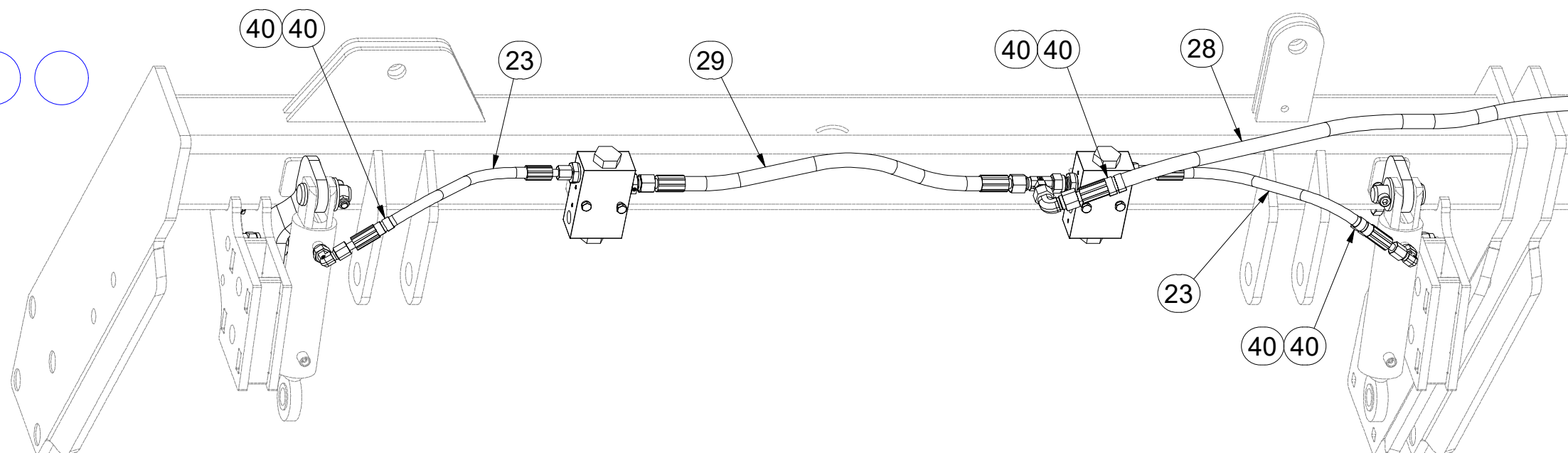
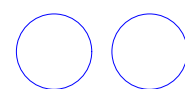
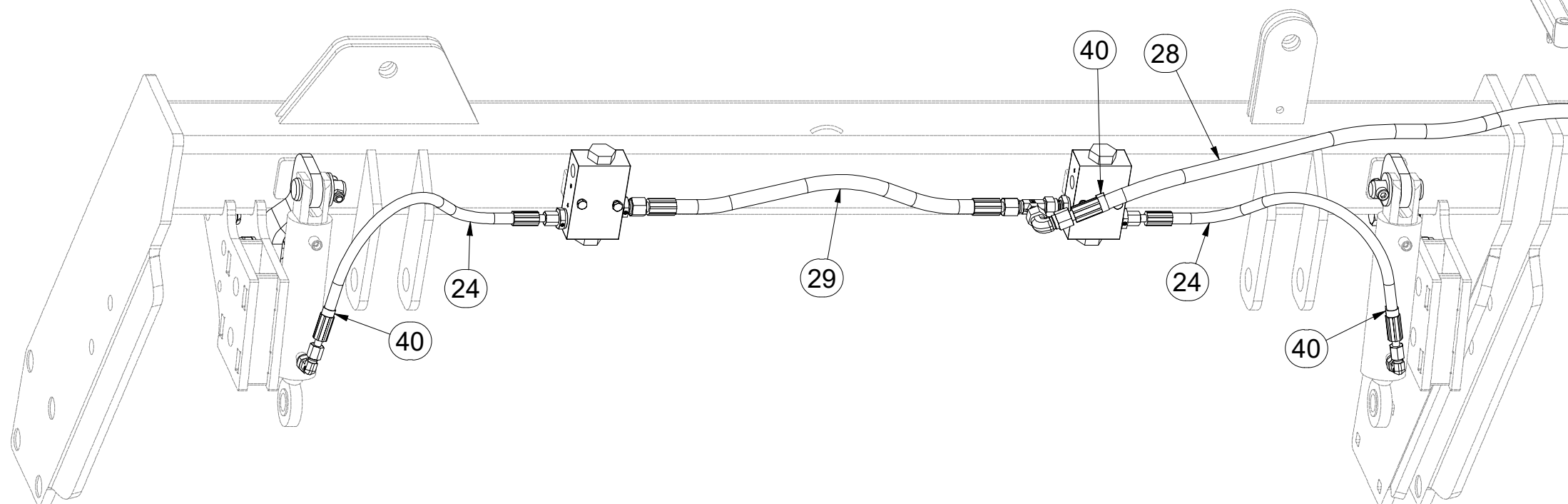
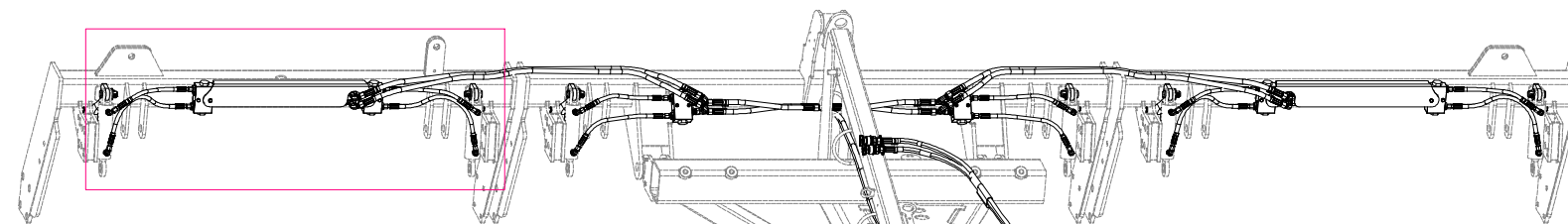

| Pos. | Part Number | Pcs. |
|------|-------------|------|
| 23 | m13023 | 4 |
| 24 | m13026 | 4 |
| 28 | m06533 | 4 |
| 29 | m11126 | 4 |
| 40 | m11253 | 42 |

ⒸZ SADA PŘEDNÍCH SMYKŮ

Ⓓ SATZ VORDERE ACKERSCHLEPPEN

Ⓕ KIT DE NIVELEURS AVANT

ⒼB SET OF FRONT LEVELLING BARS

ⒶU КОМПЛЕКТ ПЕРЕДНИХ БОРОН

ⒶL ZESTAW PRZEDNICH WŁÓK



3006506

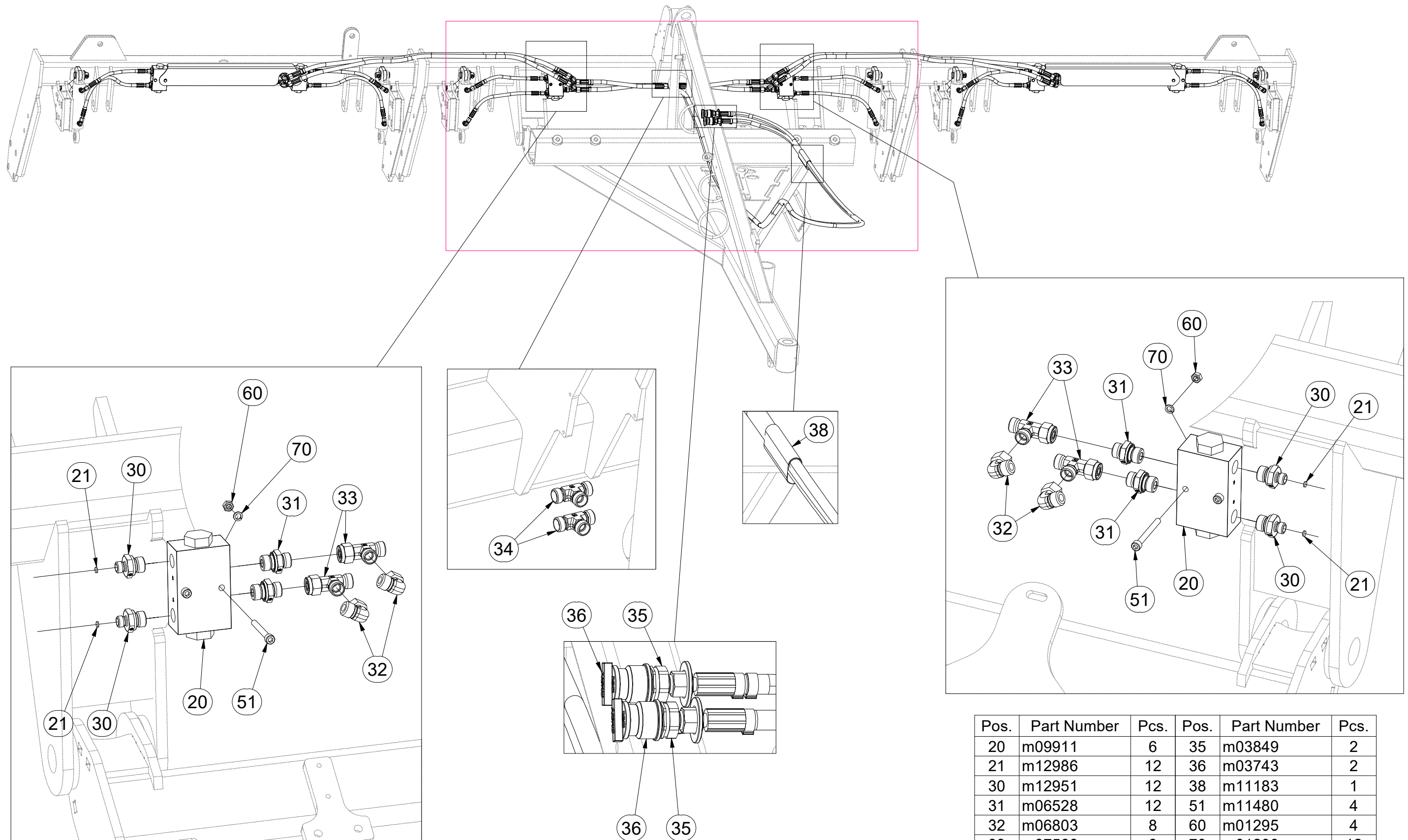

| Pos. | Part Number | Pcs. | Pos. | Part Number | Pcs. |
|------|-------------|------|------|-------------|------|
| 20 | m09911 | 6 | 35 | m03849 | 2 |
| 21 | m12986 | 12 | 36 | m03743 | 2 |
| 30 | m12951 | 12 | 38 | m11183 | 1 |
| 31 | m06528 | 12 | 51 | m11480 | 4 |
| 32 | m06803 | 8 | 60 | m01295 | 4 |
| 33 | m07568 | 8 | 70 | m01200 | 12 |
| 34 | m03889 | 2 | | | |

Ⓒ SADA PŘEDNÍCH SMYKŮ

Ⓓ SATZ VORDERE ACKERSCHLEPPEN

Ⓕ KIT DE NIVELEURS AVANT

3006506

Ⓖ SET OF FRONT LEVELLING BARS

Ⓔ КОМПЛЕКТ ПЕРЕДНИХ БОРОН

Ⓗ ZESTAW PRZEDNICH WŁÓK

Farmet

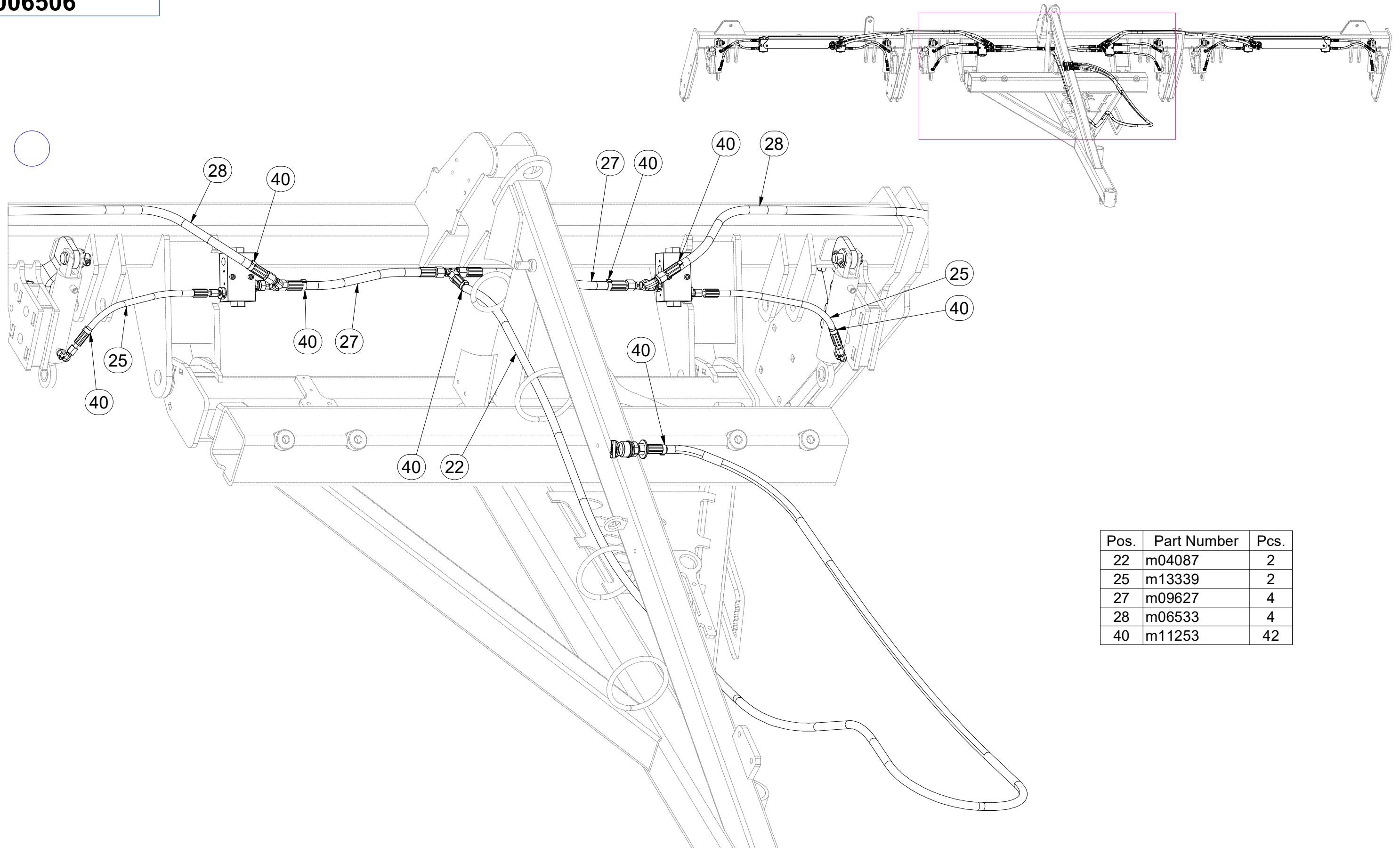

| Pos. | Part Number | Pcs. |
|------|-------------|------|
| 22 | m04087 | 2 |
| 25 | m13339 | 2 |
| 27 | m09627 | 4 |
| 28 | m06533 | 4 |
| 40 | m11253 | 42 |

ⒸZ SADA PŘEDNÍCH SMYKŮ

Ⓓ SATZ VORDERE ACKERSCHLEPPEN

Ⓕ KIT DE NIVELEURS AVANT

ⒸB SET OF FRONT LEVELLING BARS

ⒸR КОМПЛЕКТ ПЕРЕДНИХ БОРОН

ⒸL ZESTAW PRZEDNICH WŁÓK

Farmet

3006506

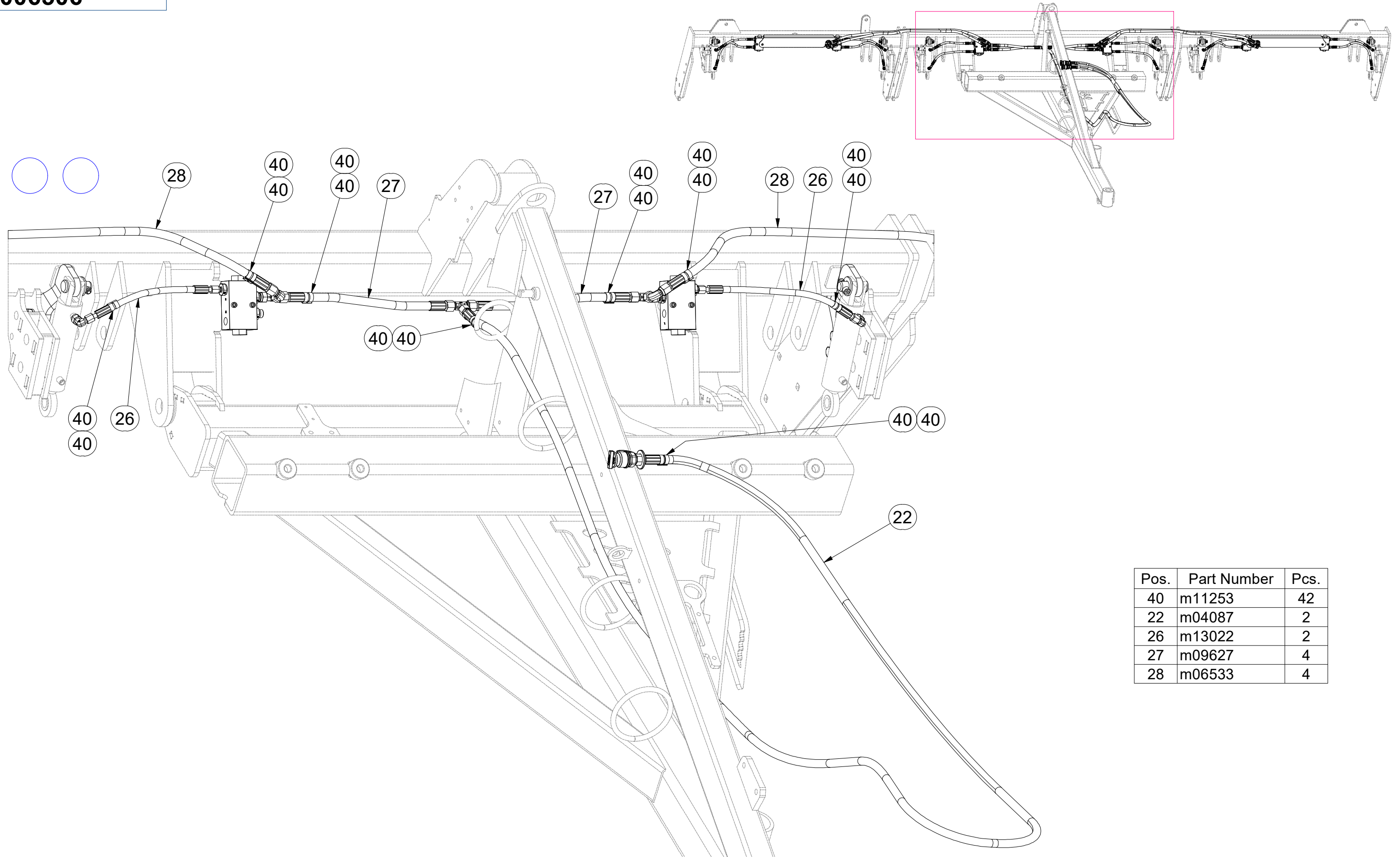

| Pos. | Part Number | Pcs. |
|------|-------------|------|
| 40 | m11253 | 42 |
| 22 | m04087 | 2 |
| 26 | m13022 | 2 |
| 27 | m09627 | 4 |
| 28 | m06533 | 4 |

ⒸZ SADA PŘEDNÍCH SMYKŮ

Ⓓ SATZ VORDERE ACKERSCHLEPPEN

Ⓕ KIT DE NIVELEURS AVANT

ⒼB SET OF FRONT LEVELLING BARS

ⒺU КОМПЛЕКТ ПЕРЕДНИХ БОРОН

ⒼL ZESTAW PRZEDNICH WŁÓK



3006506

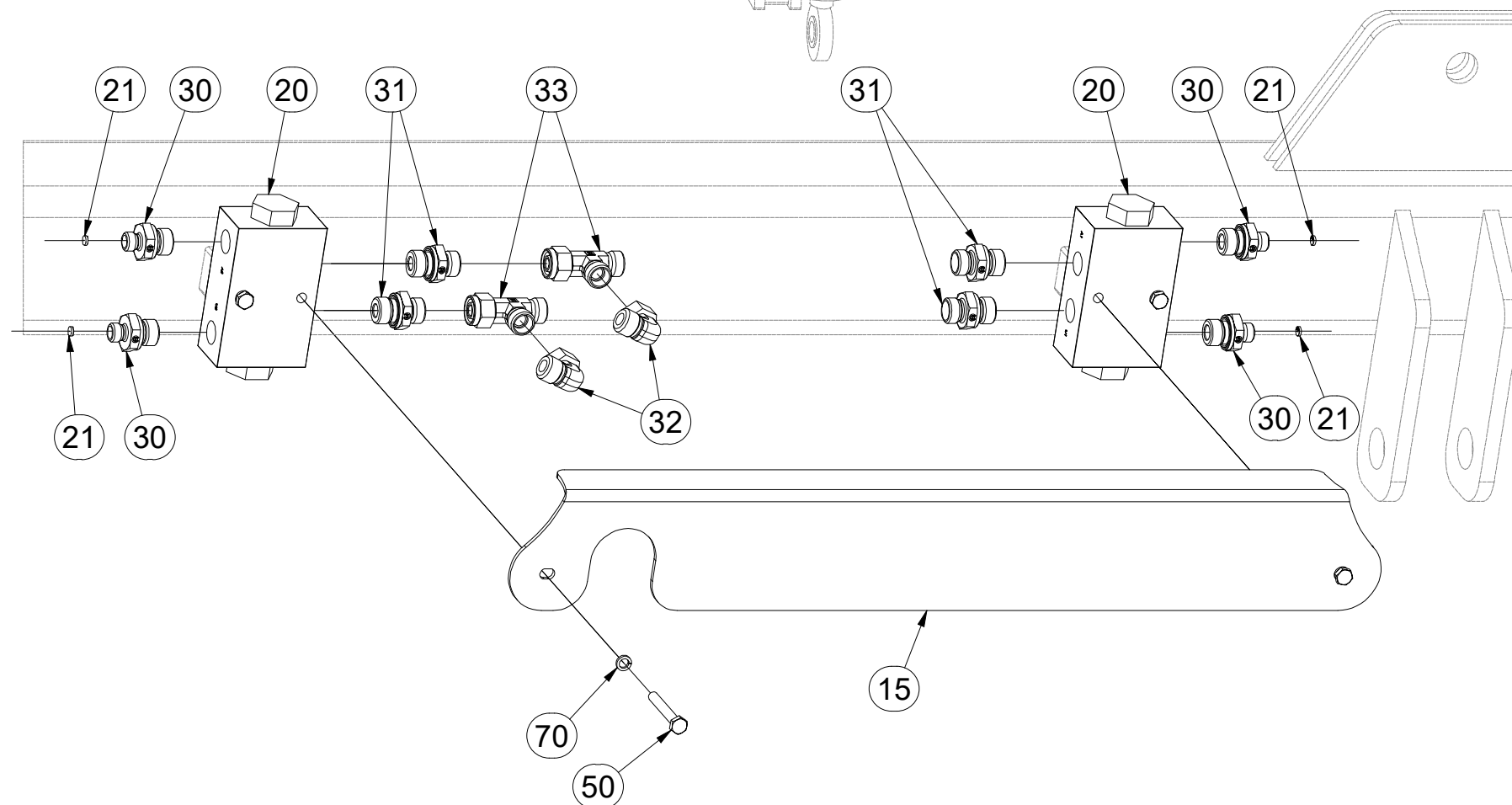
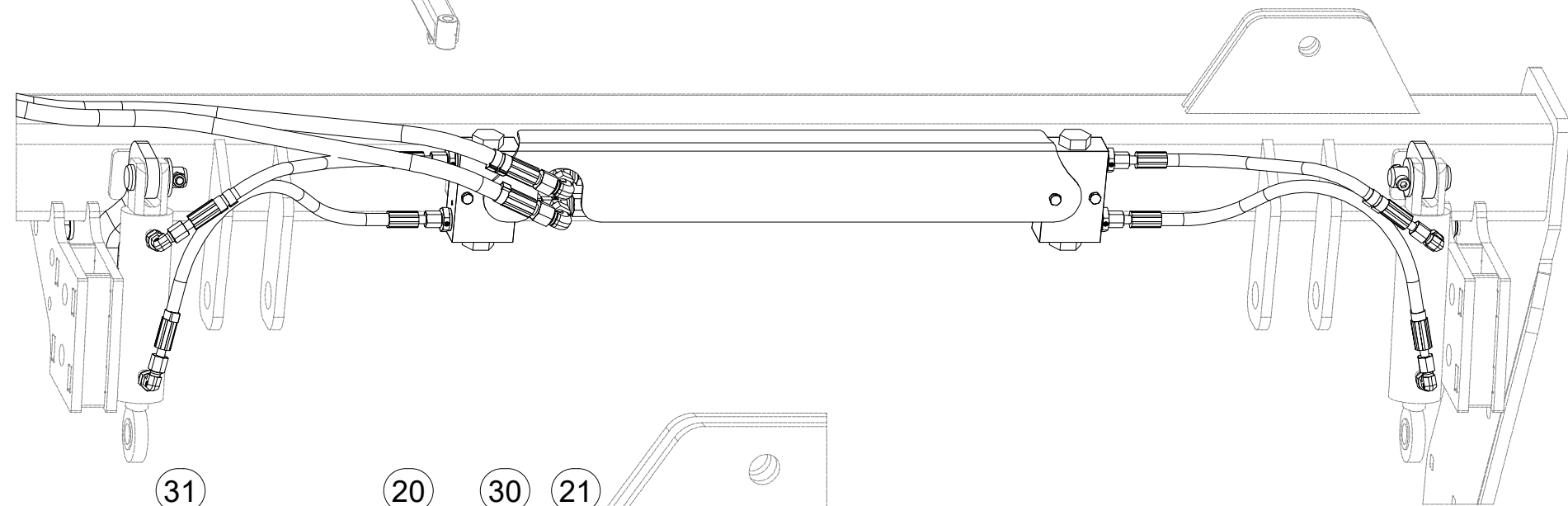
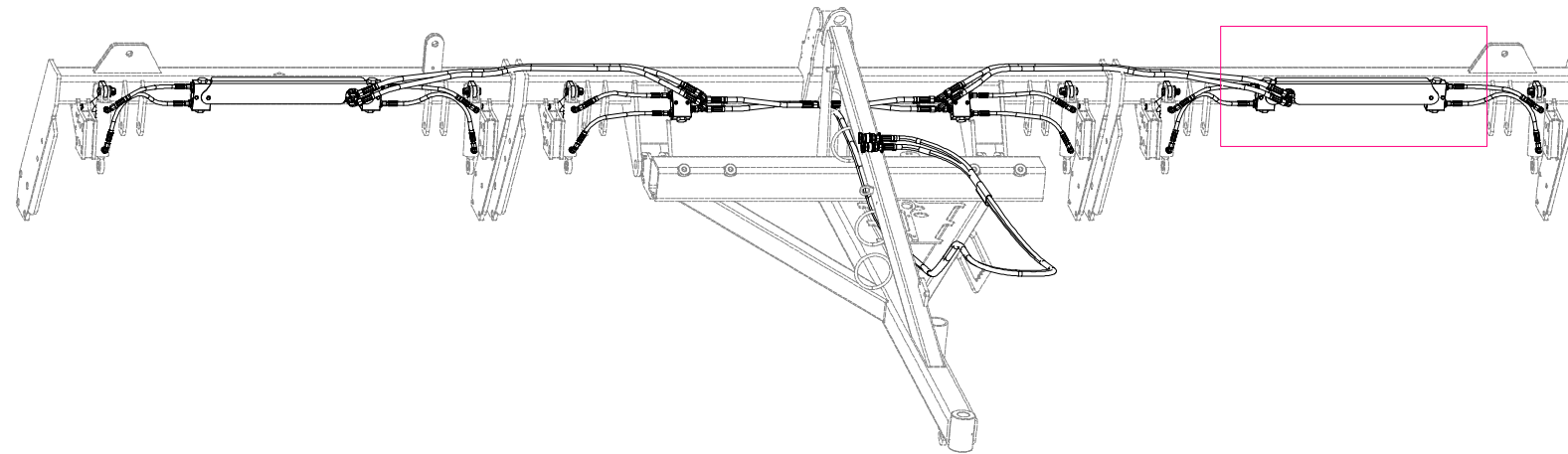

| Pos. | Part Number | Pcs. |
|------|-------------|------|
| 15 | 4018113 | 1 |
| 20 | m09911 | 6 |
| 21 | m12986 | 12 |
| 30 | m12951 | 12 |
| 31 | m06528 | 12 |
| 32 | m06803 | 8 |
| 33 | m07568 | 8 |
| 50 | m05561 | 8 |
| 70 | m01200 | 12 |

ⒸZ SADA PŘEDNÍCH SMYKŮ

Ⓓ SATZ VORDERE ACKERSCHLEPPEN

Ⓕ KIT DE NIVELEURS AVANT

ⒼB SET OF FRONT LEVELLING BARS

ⒺR KOMПЛЕКТ ПЕРЕДНИХ БОРОН

ⒶL ZESTAW PRZEDNICH WŁÓK



3006506

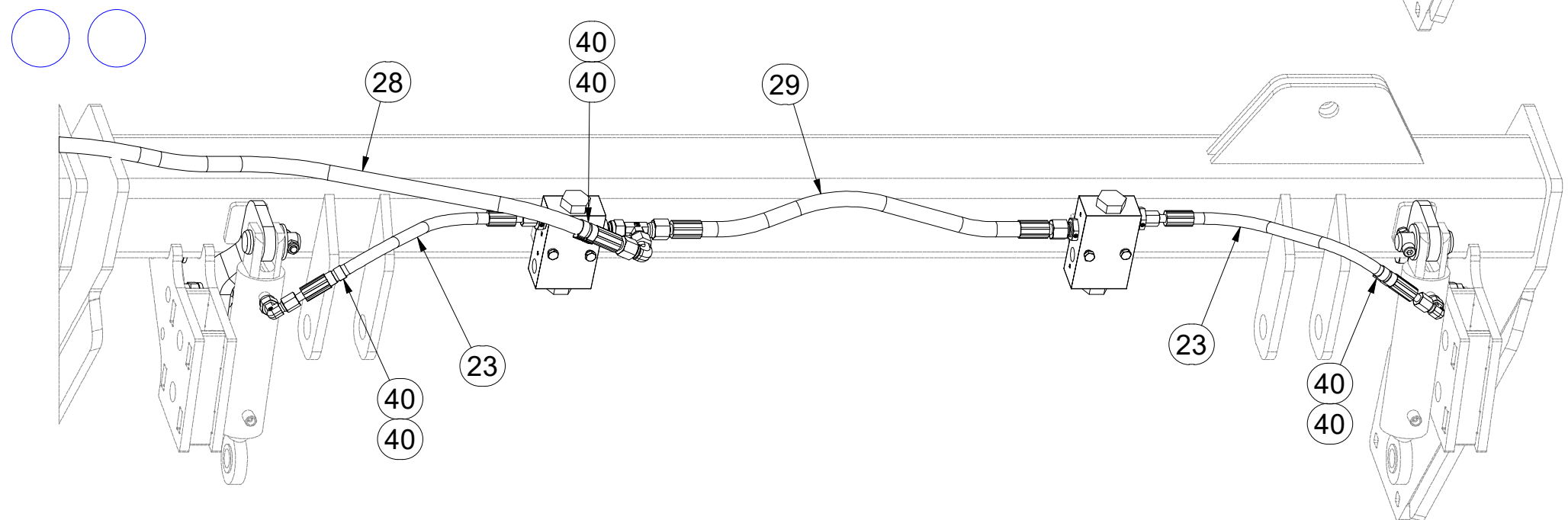
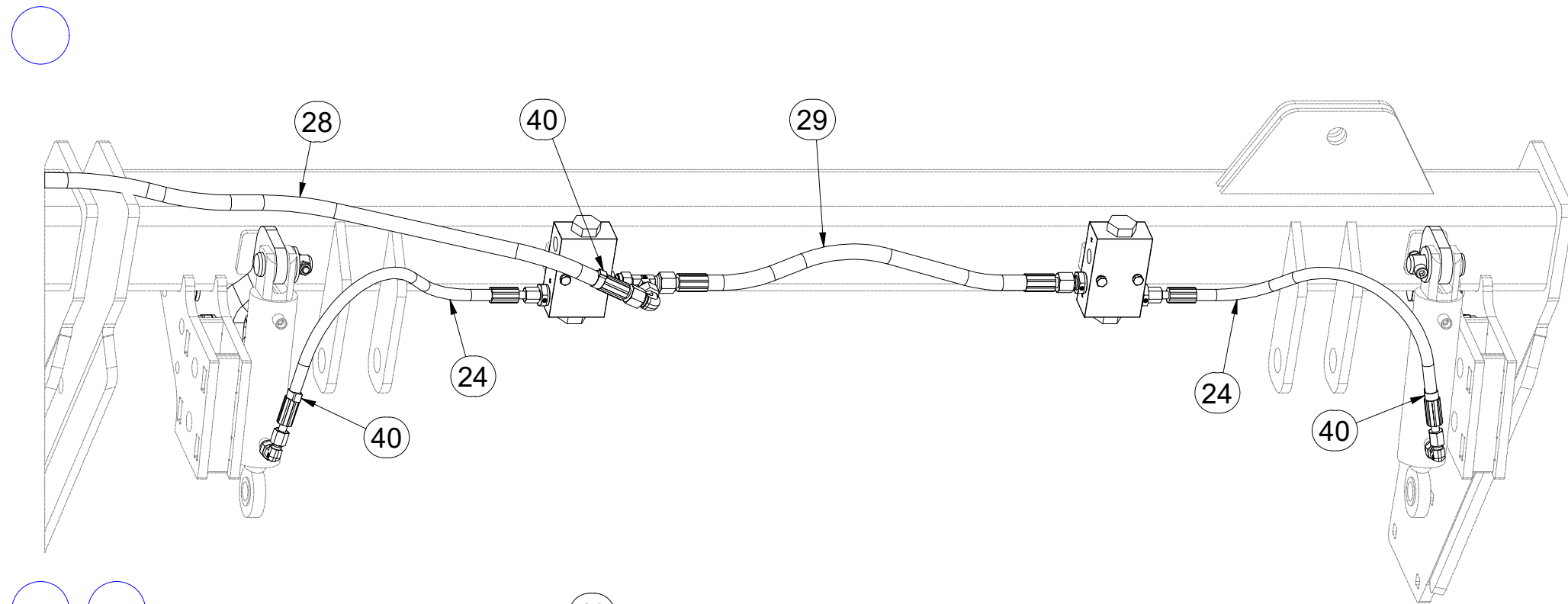
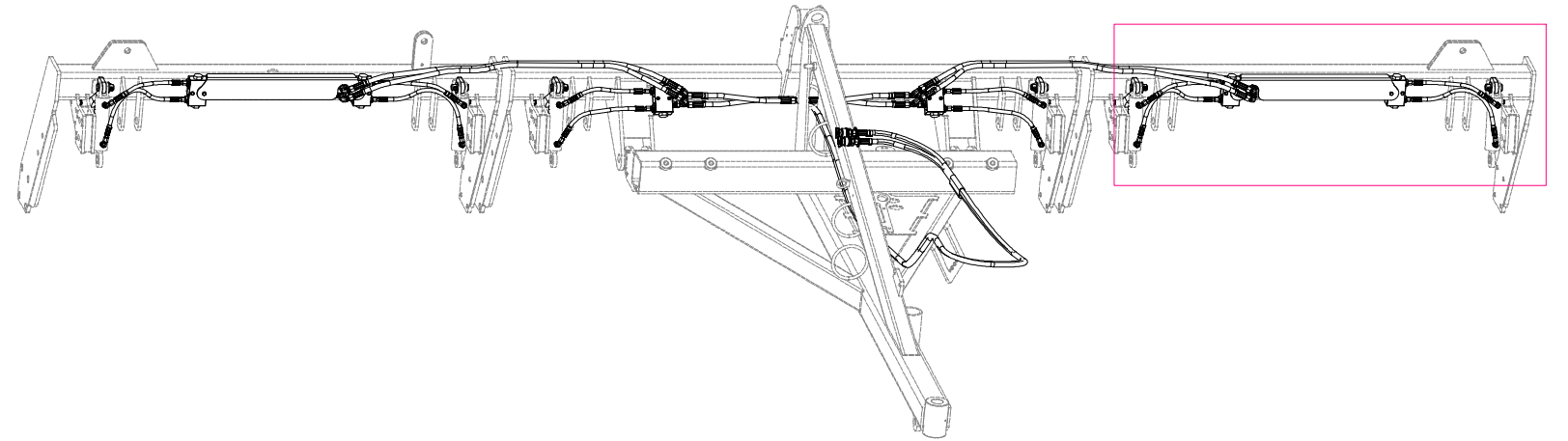

| Pos. | Part Number | Pcs. |
|------|-------------|------|
| 23 | m13023 | 4 |
| 24 | m13026 | 4 |
| 28 | m06533 | 4 |
| 29 | m11126 | 4 |
| 40 | m11253 | 42 |

ⒸZ SADA PŘEDNÍCH SMYKŮ

Ⓓ SATZ VORDERE ACKERSCHLEPPEN

Ⓕ KIT DE NIVELEURS AVANT

3006506

ⒸGB SET OF FRONT LEVELLING BARS

ⒸRU КОМПЛЕКТ ПЕРЕДНИХ БОРОН

ⒸPL ZESTAW PRZEDNICH WŁÓK

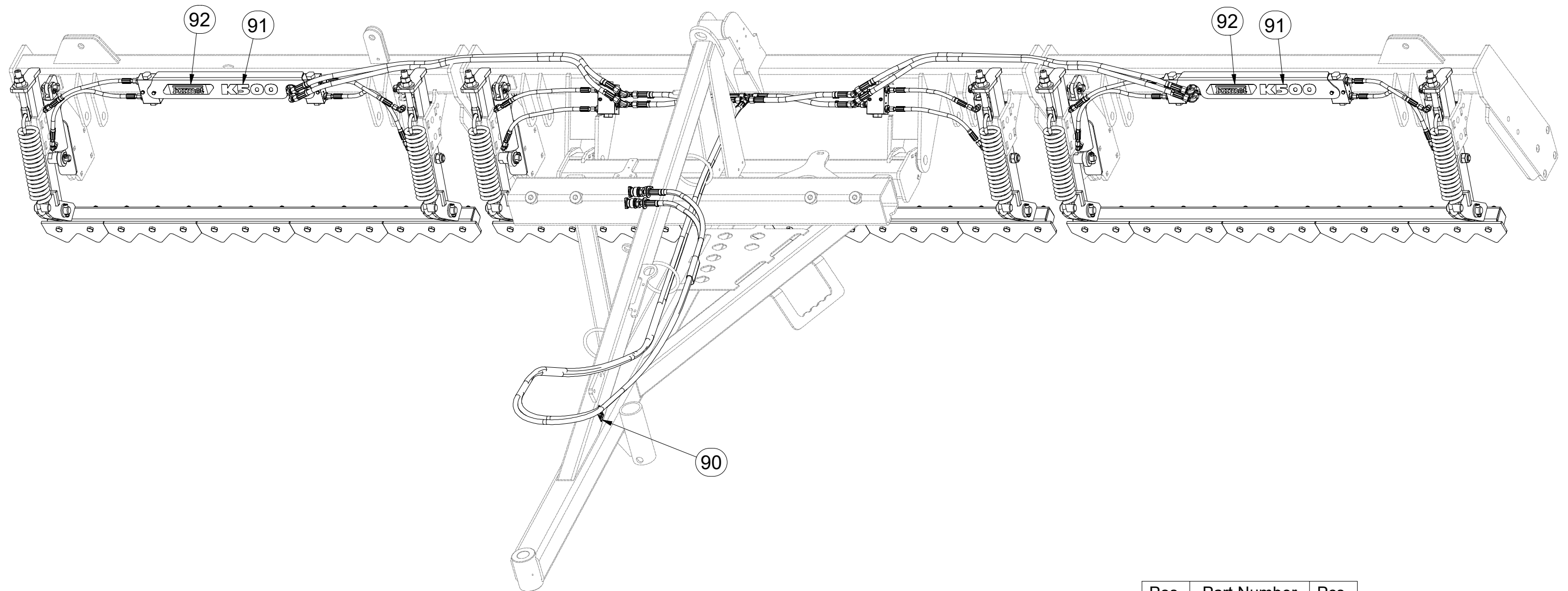

| Pos. | Part Number | Pcs. |
|------|-------------|------|
| 90 | m11653 | 1 |
| 91 | m07692 | 2 |
| 92 | m14551 | 2 |

Ⓒ PŘEDNÍ SMYK

Ⓓ VORDERE ACKERSCHLEIFE

Ⓕ NIVELEUR AVANT

Ⓖ FRONT DRAG

Ⓡ ПЕРЕДНЯЯ БОРОНА

Ⓟ PRZEDNIA WŁÓKA

Farmet

3010749

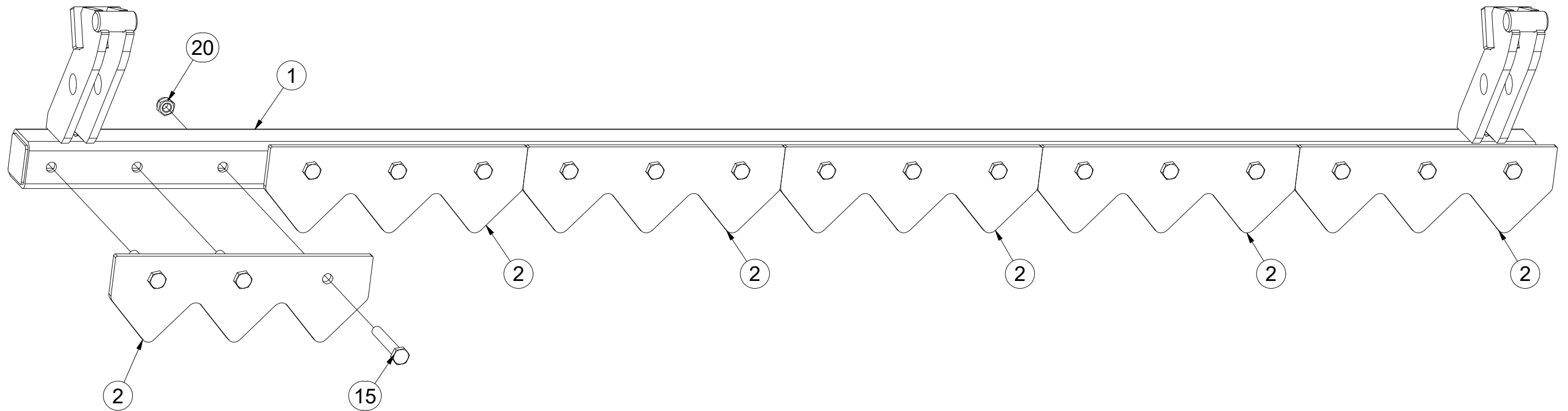

| Pos. | Part Number | Pcs. |
|------|-------------|------|
| 1 | 3010748 | 1 |
| 2 | 4021741 | 6 |
| 15 | m09437 | 18 |
| 20 | m04301 | 18 |

Ⓒ PŘEDNÍ SMYK

Ⓓ VORDERE ACKERSCHLEIFE

Ⓕ NIVELEUR AVANT

Ⓖ FRONT DRAG

Ⓡ ПЕРЕДНЯЯ БОРОНА

Ⓟ PRZEDNIA WŁÓKA

Farmet

3011432

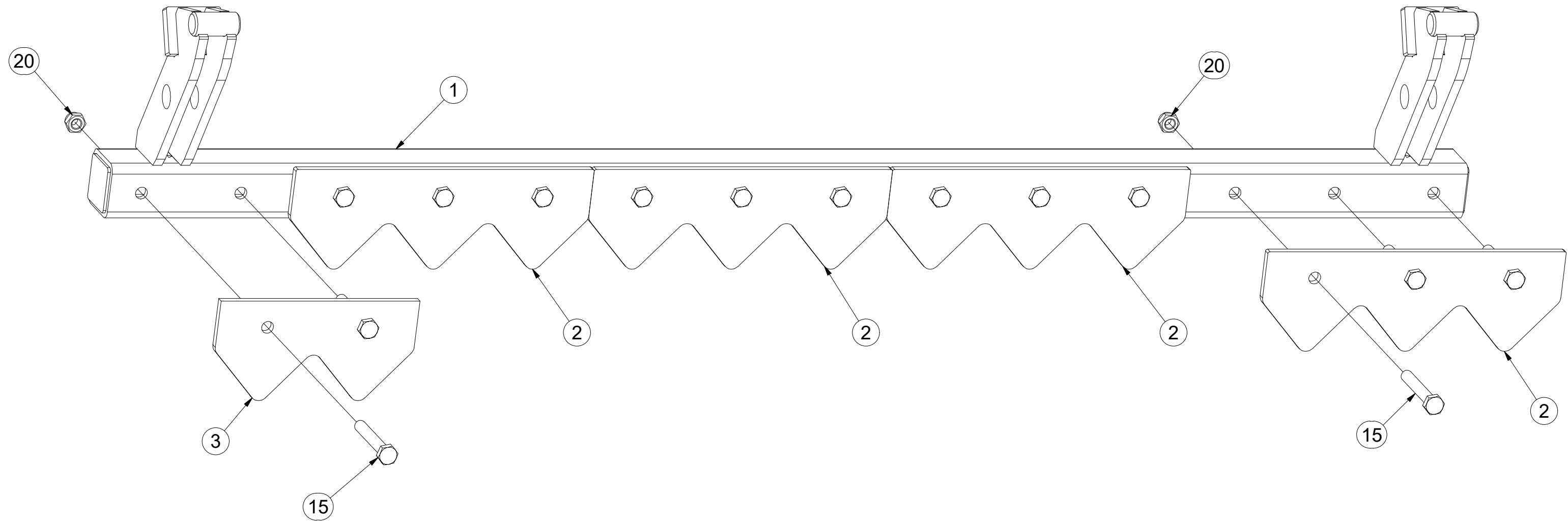

| Pos. | Part Number | Pcs. |
|------|-------------|------|
| 1 | 3011431 | 1 |
| 2 | 4021741 | 4 |
| 3 | 4023094 | 1 |
| 15 | m09437 | 14 |
| 20 | m04301 | 14 |

ⒸZ SADA PŘEDNÍCH VÁLCŮ

Ⓓ SATZ VORDERE WALZEN

Ⓕ KIT DE ROULEAUX AVANT

ⒸB SET OF FRONT ROLLERS

ⒹU КОМПЛЕКТ ПЕРЕДНИХ КАТКОВ

ⒹL ZESTAW PRZEDNICH WAŁÓW



3011902

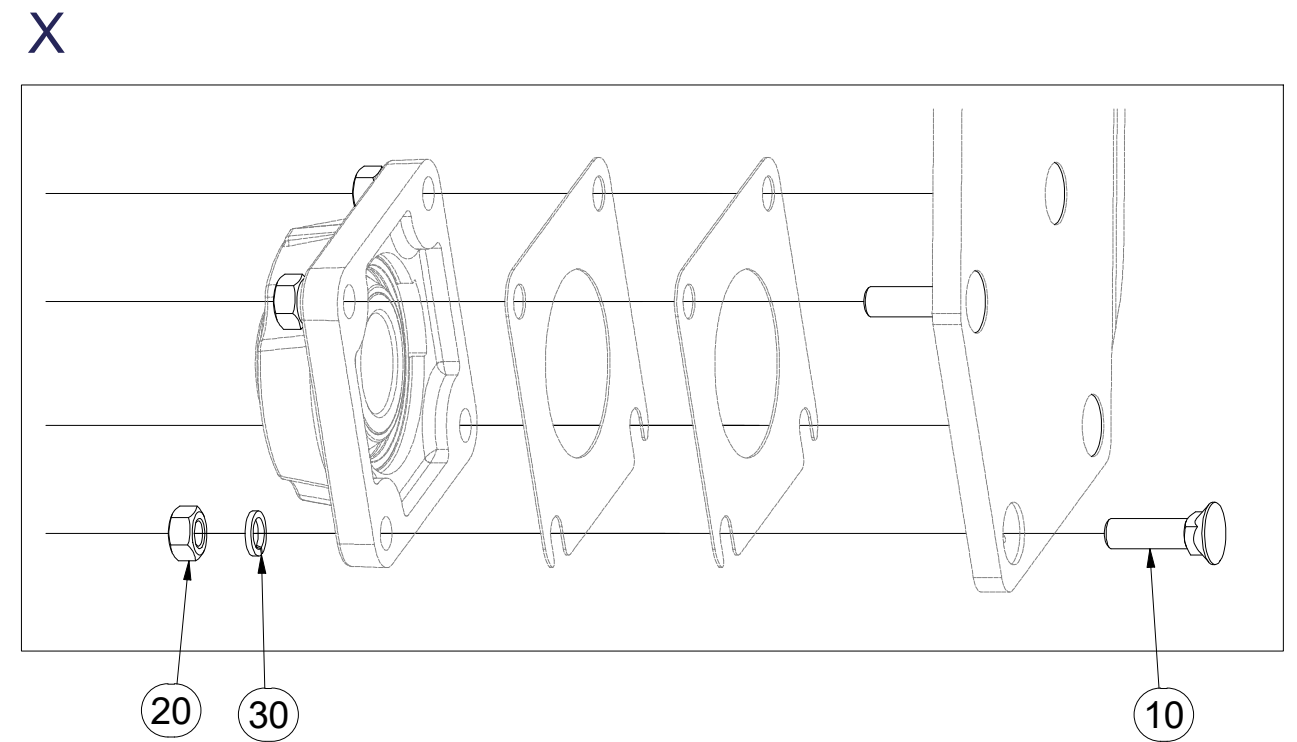
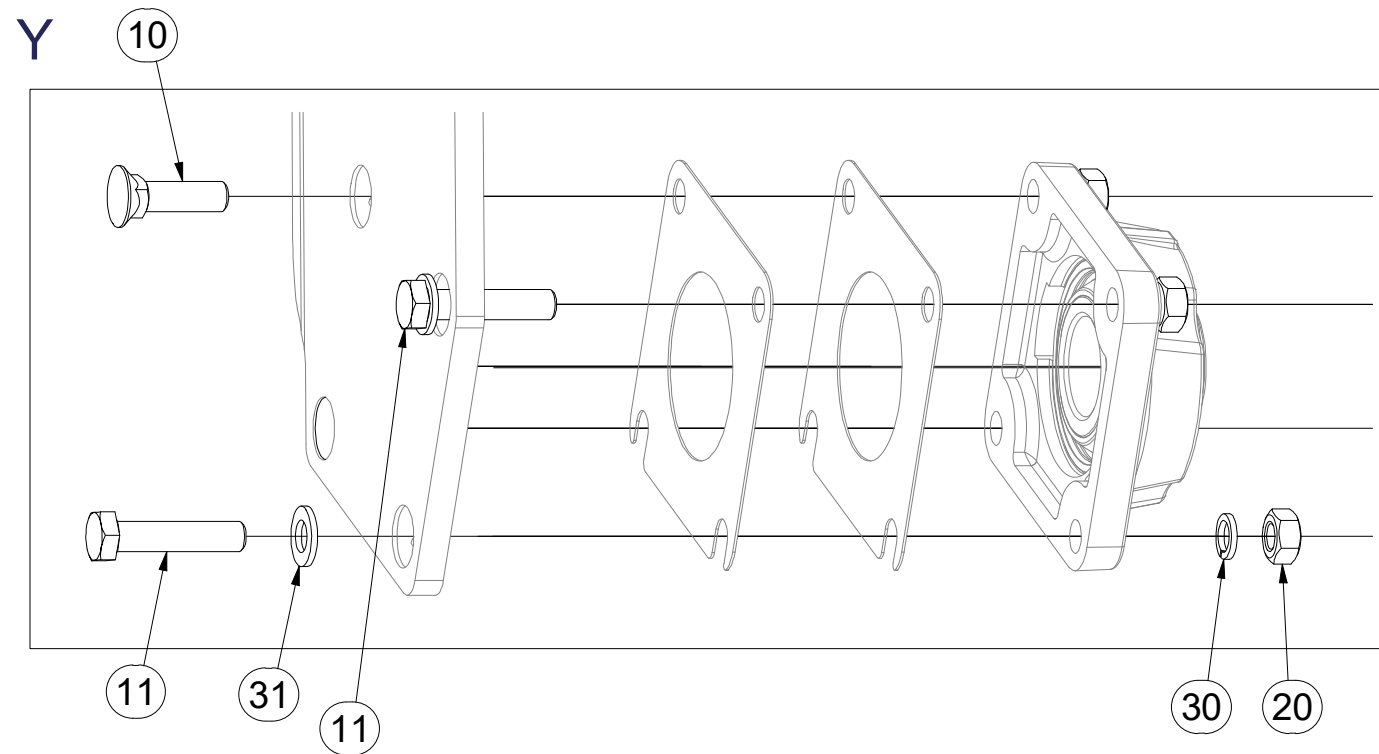
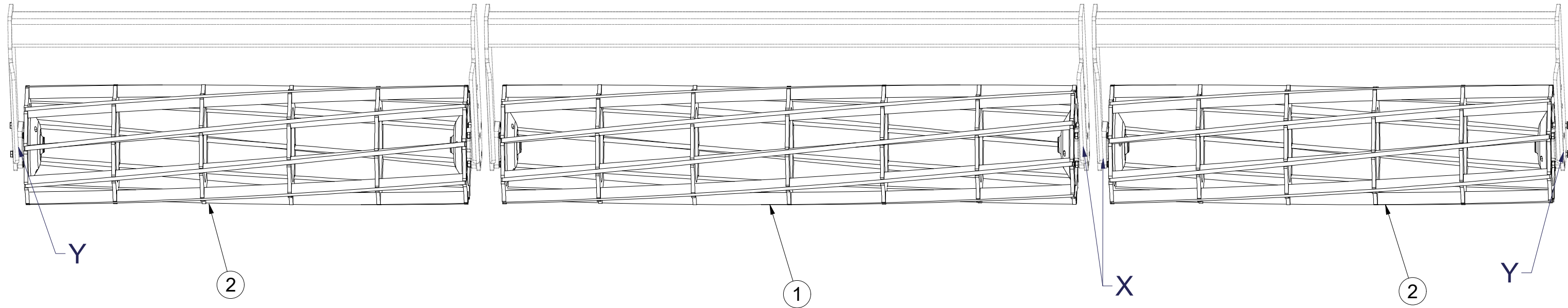

| Pos. | Part Number | Pcs. | Pos. | Part Number | Pcs. |
|------|-------------|------|------|-------------|------|
| 1 | 2000679 | 1 | 20 | m01305 | 24 |
| 2 | 2001150 | 2 | 30 | m03988 | 24 |
| 10 | m03519 | 20 | 31 | m17741 | 4 |
| 11 | m04412 | 4 | | | |

- Ⓒ SADA LOŽISEK
- Ⓓ SATZ LAGER
- Ⓕ KIT DE ROULEMENTS

- Ⓖ SET OF BEARINGS
- Ⓡ КОМПЛЕКТ ПОДШИПНИКОВ
- Ⓟ ZESTAW ŁOŻYSK



VZ00012425

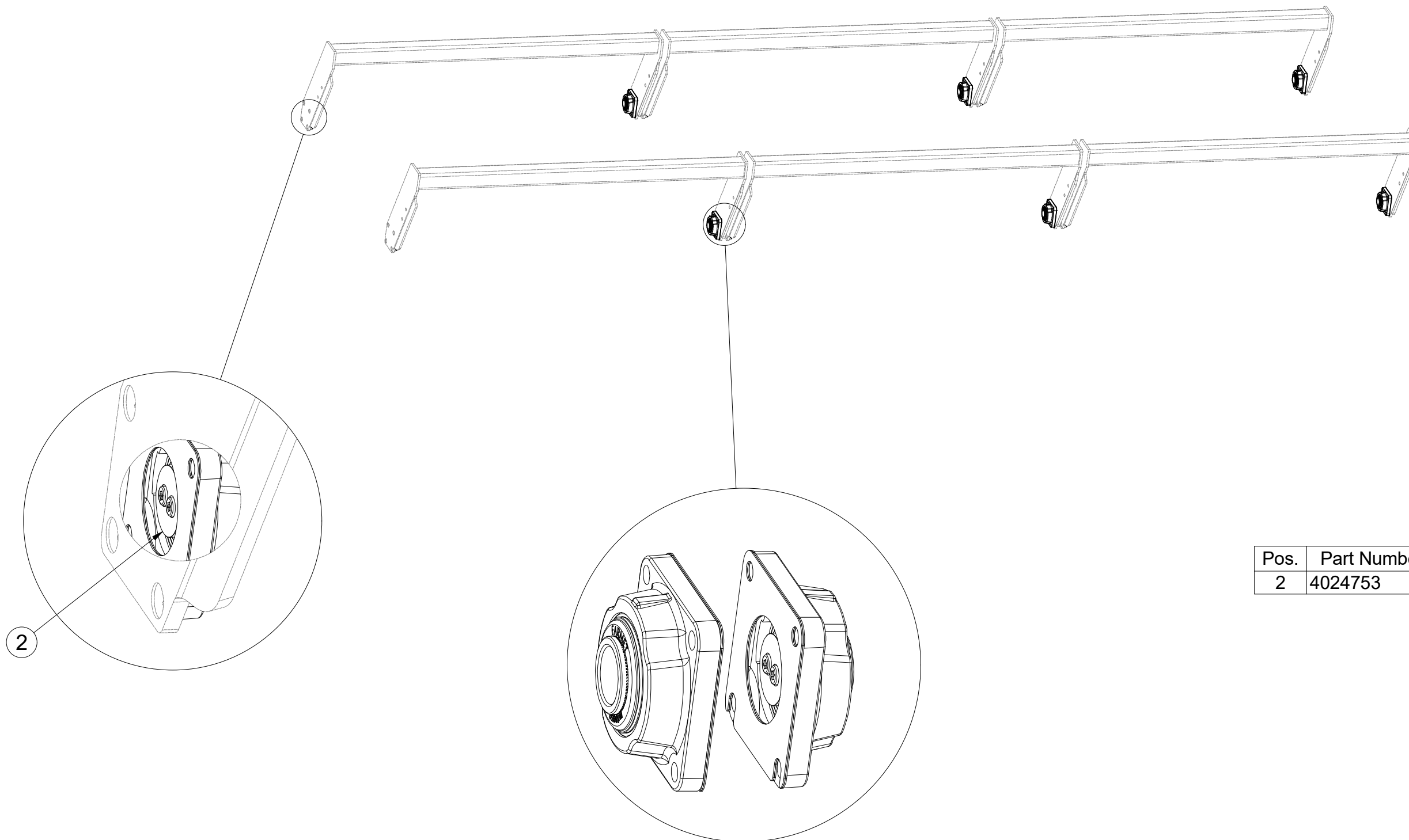

| Pos. | Part Number | Pcs. |
|------|-------------|------|
| 2 | 4024753 | 12 |

(CZ) SADA LOŽISEK
 (D) SATZ LAGER
 (F) KIT DE ROULEMENTS

(GB) SET OF BEARINGS
 (RU) КОМПЛЕКТ ПОДШИПНИКОВ
 (PL) ZESTAW ŁOŻYSK



VZ00012425

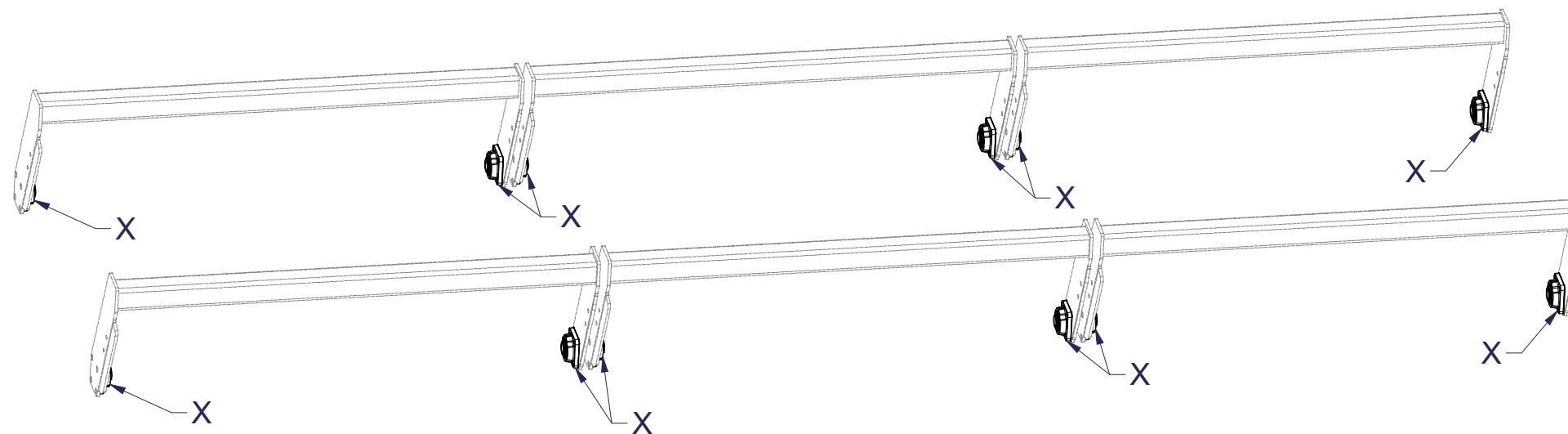

X

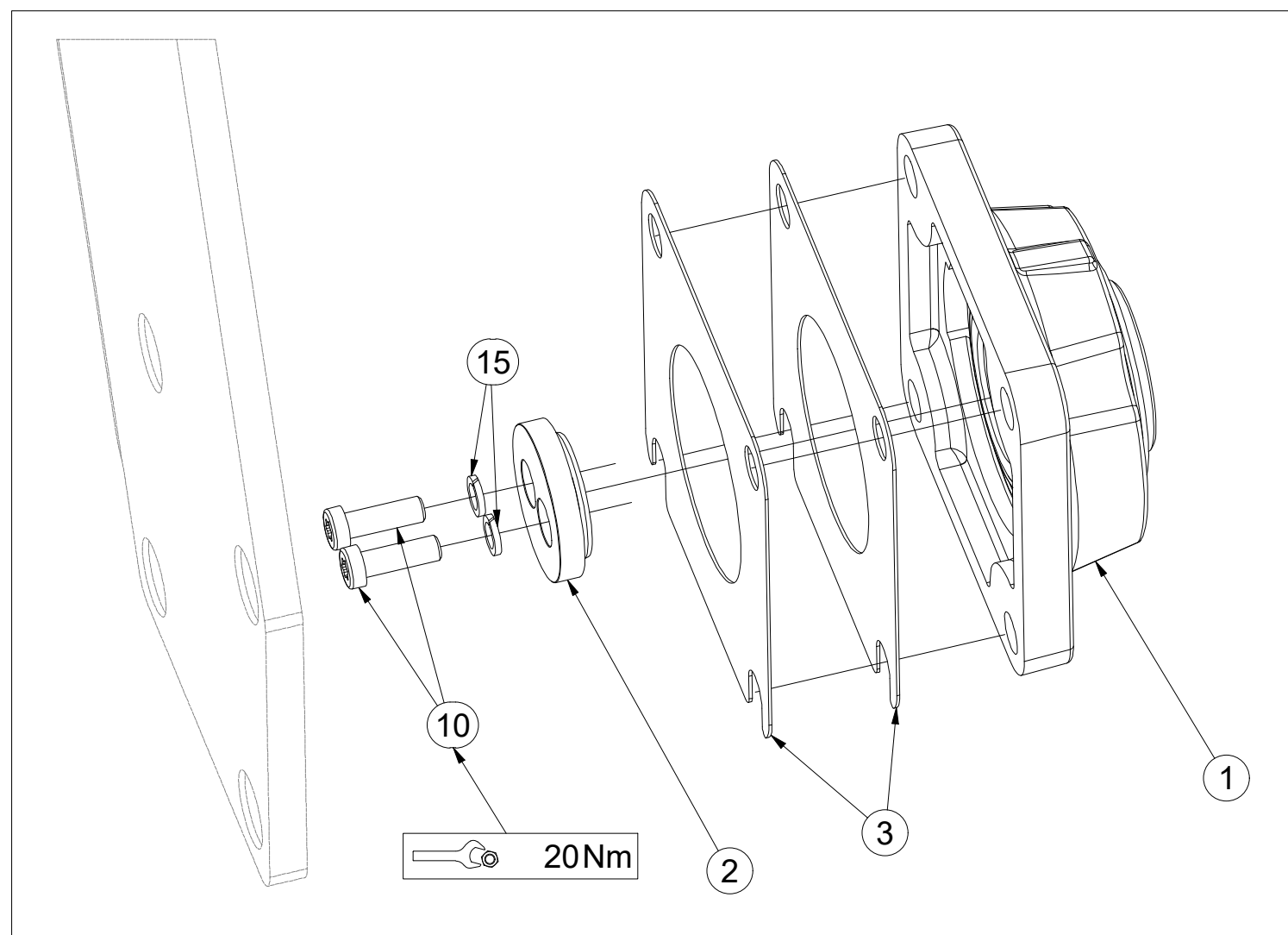

| Pos. | Part Number | Pcs. |
|------|-------------|------|
| 1 | m18650 | 12 |
| 2 | 4024753 | 12 |
| 3 | 4016809 | 24 |
| 10 | m18858 | 24 |
| 15 | m01202 | 24 |

Ⓒ SADA OVLÁDÁNÍ RADLICE

Ⓓ STEUERSATZ PFLUGSCHAREN

Ⓕ KIT DE COMMANDE DES SOCS

Ⓖ SET OF PLOUGHSHARE CONTROL

Ⓡ КОМПЛЕКТ УПРАВЛЕНИЯ ЛАП

Ⓢ ZESTAW STEROWANIA RADLICAMI



3011966

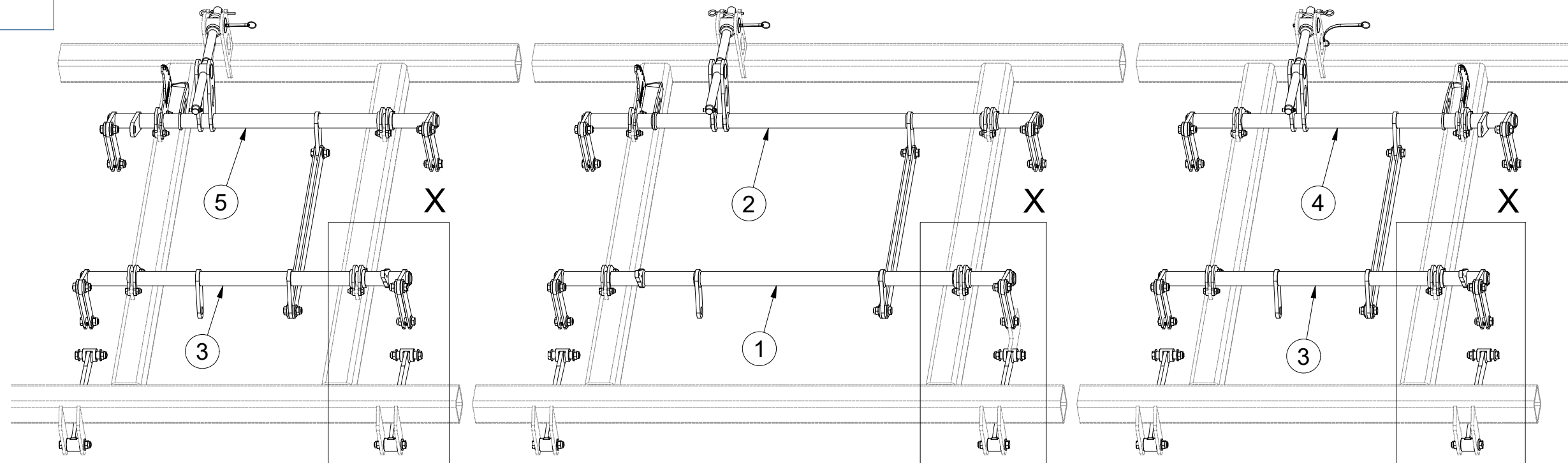

X

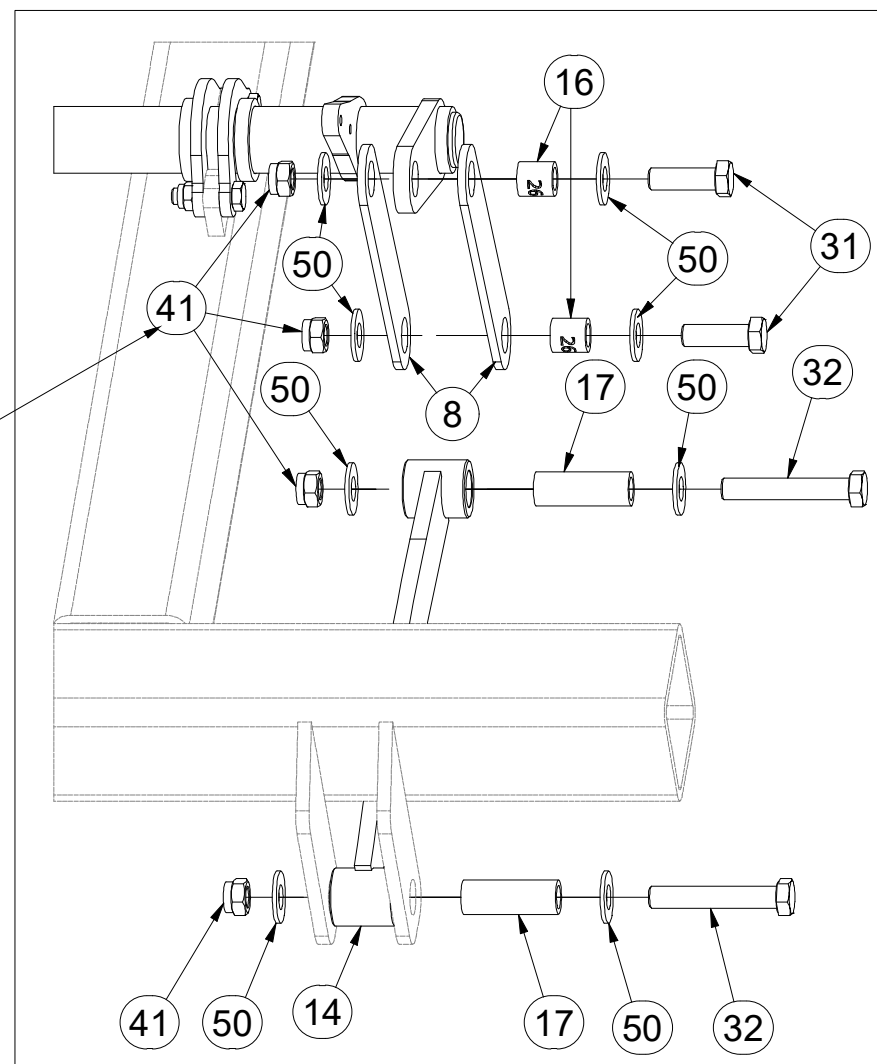

60Nm

| Pos. | Part Number | Pcs. | Pos. | Part Number | Pcs. |
|------|-------------|------|------|-------------|------|
| 1 | VZ00007199 | 1 | 16 | 4002265 | 30 |
| 2 | 3002831 | 1 | 17 | 9001426 | 12 |
| 3 | VZ00007789 | 2 | 31 | m04355 | 30 |
| 4 | VZ00021523 | 1 | 32 | m07673 | 12 |
| 5 | VZ00021524 | 1 | 41 | m03683 | 42 |
| 8 | 4005333 | 24 | 50 | m05651 | 84 |
| 14 | VZ00003342 | 6 | | | |

ⒸZ SADA OVLÁDÁNÍ RADLICE

Ⓓ STEUERSATZ PFLUGSCHAREN

Ⓕ KIT DE COMMANDE DES SOCS

ⒸB SET OF PLOUGHSHARE CONTROL

ⒸU КОМПЛЕКТ УПРАВЛЕНИЯ ЛАП

ⒸL ZESTAW STEROWANIA RADLICAMI



3011966

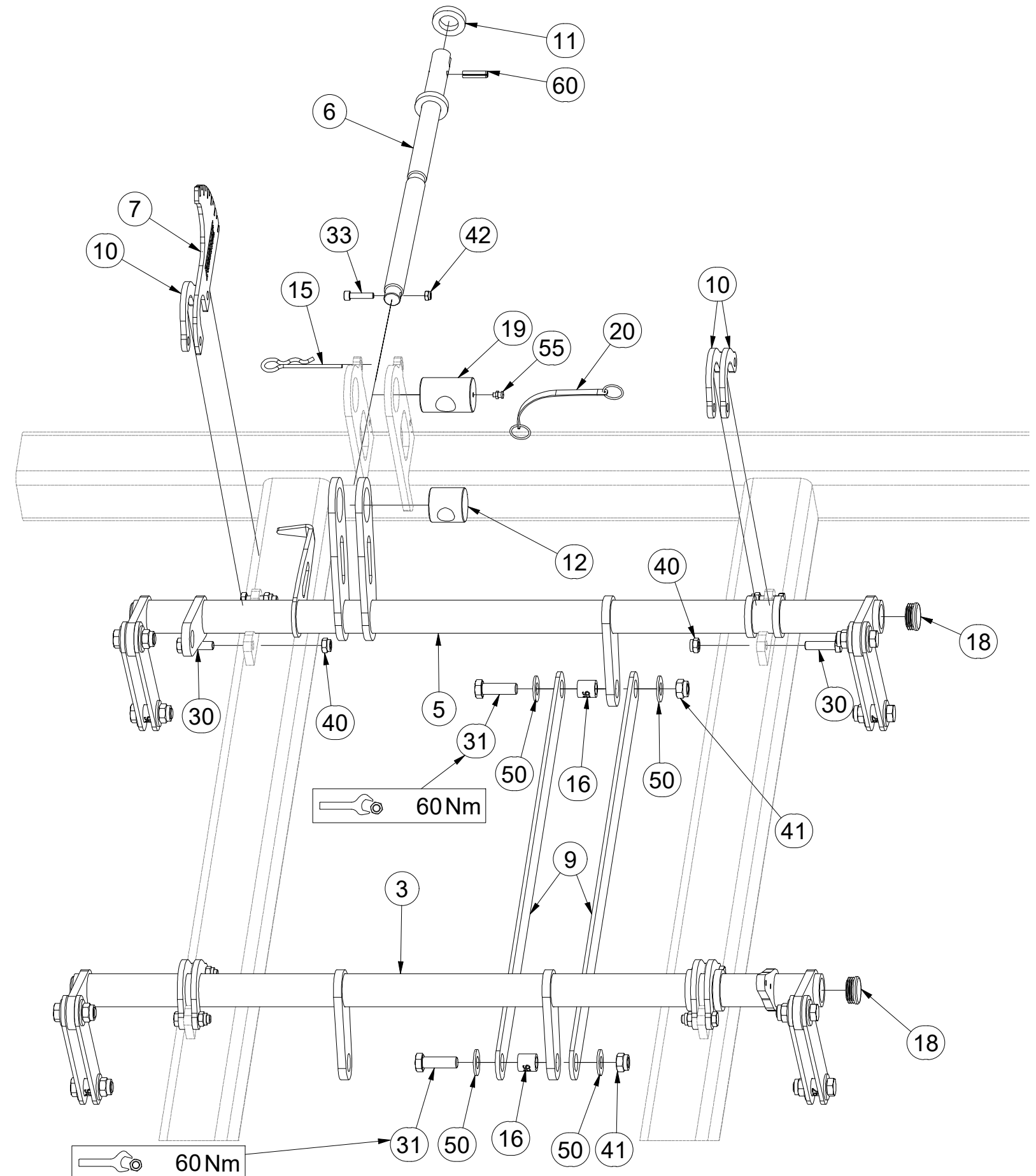
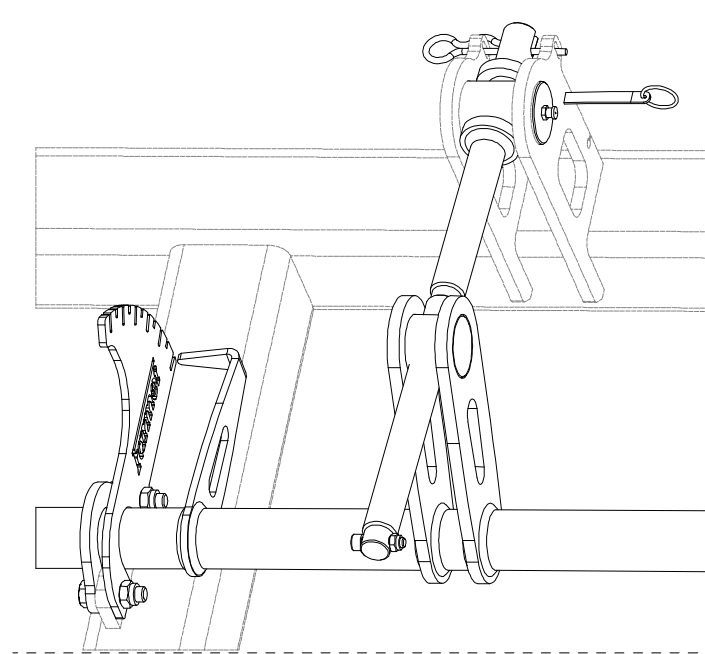
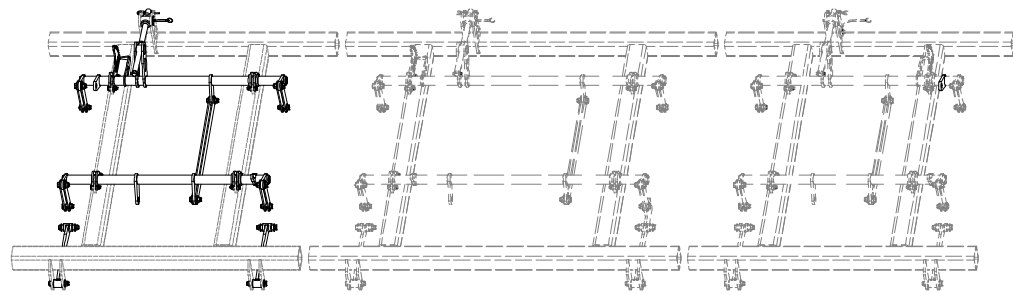

| Pos. | Part Number | Pcs. | Pos. | Part Number | Pcs. |
|------|-------------|------|------|-------------|------|
| 3 | VZ00007789 | 2 | 19 | 9002114 | 3 |
| 5 | VZ00021524 | 1 | 20 | m12467 | 3 |
| 6 | 4024250 | 3 | 30 | m06077 | 24 |
| 7 | 4023896 | 3 | 31 | m04355 | 30 |
| 9 | 4005334 | 6 | 33 | m09464 | 3 |
| 10 | 4005332 | 21 | 40 | m04301 | 24 |
| 11 | 9002560 | 3 | 41 | m03683 | 42 |
| 12 | 4005340 | 3 | 42 | m04503 | 3 |
| 15 | m09988 | 3 | 50 | m05651 | 84 |
| 16 | 4002265 | 30 | 55 | m10451 | 3 |
| 18 | m10130 | 12 | 60 | m10736 | 3 |

Ⓒ CZ SADA OVLÁDÁNÍ RADLICE

Ⓓ STEUERSATZ PFLUGSCHAREN

Ⓕ KIT DE COMMANDE DES SOCS

Ⓒ GB SET OF PLOUGHSHARE CONTROL

Ⓓ RU КОМПЛЕКТ УПРАВЛЕНИЯ ЛАП

Ⓕ PL ZESTAW STEROWANIA RADLICAMI



3011966

| Pos. | Part Number | Pcs. |
|------|-------------|------|
| 1 | VZ00007199 | 1 |
| 2 | 3002831 | 1 |
| 6 | 4024250 | 3 |
| 7 | 4023896 | 3 |
| 9 | 4005334 | 6 |
| 10 | 4005332 | 21 |
| 11 | 9002560 | 3 |
| 12 | 4005340 | 3 |
| 15 | m09988 | 3 |
| 16 | 4002265 | 30 |
| 18 | m10130 | 12 |
| 19 | 9002114 | 3 |
| 20 | m12467 | 3 |
| 30 | m06077 | 24 |
| 31 | m04355 | 30 |
| 33 | m09464 | 3 |
| 40 | m04301 | 24 |
| 41 | m03683 | 42 |
| 42 | m04503 | 3 |
| 50 | m05651 | 84 |
| 55 | m10451 | 3 |
| 60 | m10736 | 3 |

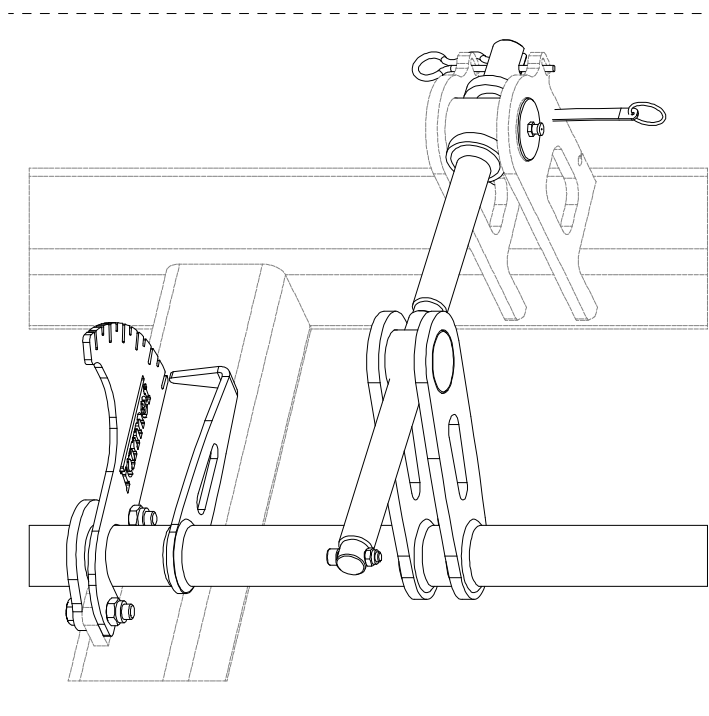
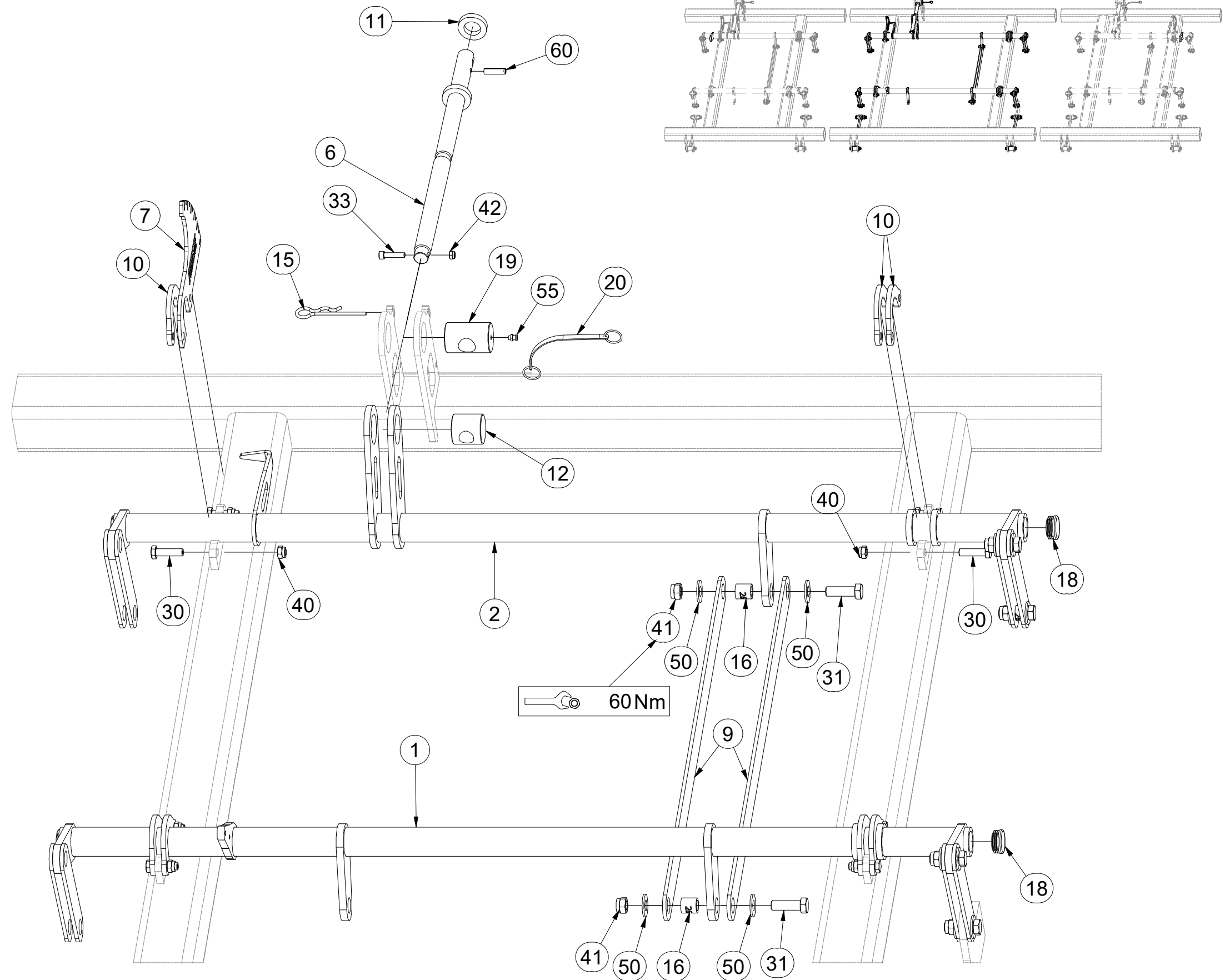

ⒸZ SADA OVLÁDÁNÍ RADLICE

Ⓓ STEUERSATZ PFLUGSCHAREN

Ⓕ KIT DE COMMANDE DES SOCS

ⒸB SET OF PLOUGHSHARE CONTROL

ⒸU КОМПЛЕКТ УПРАВЛЕНИЯ ЛАП

ⒸL ZESTAW STEROWANIA RADLICAMI



3011966

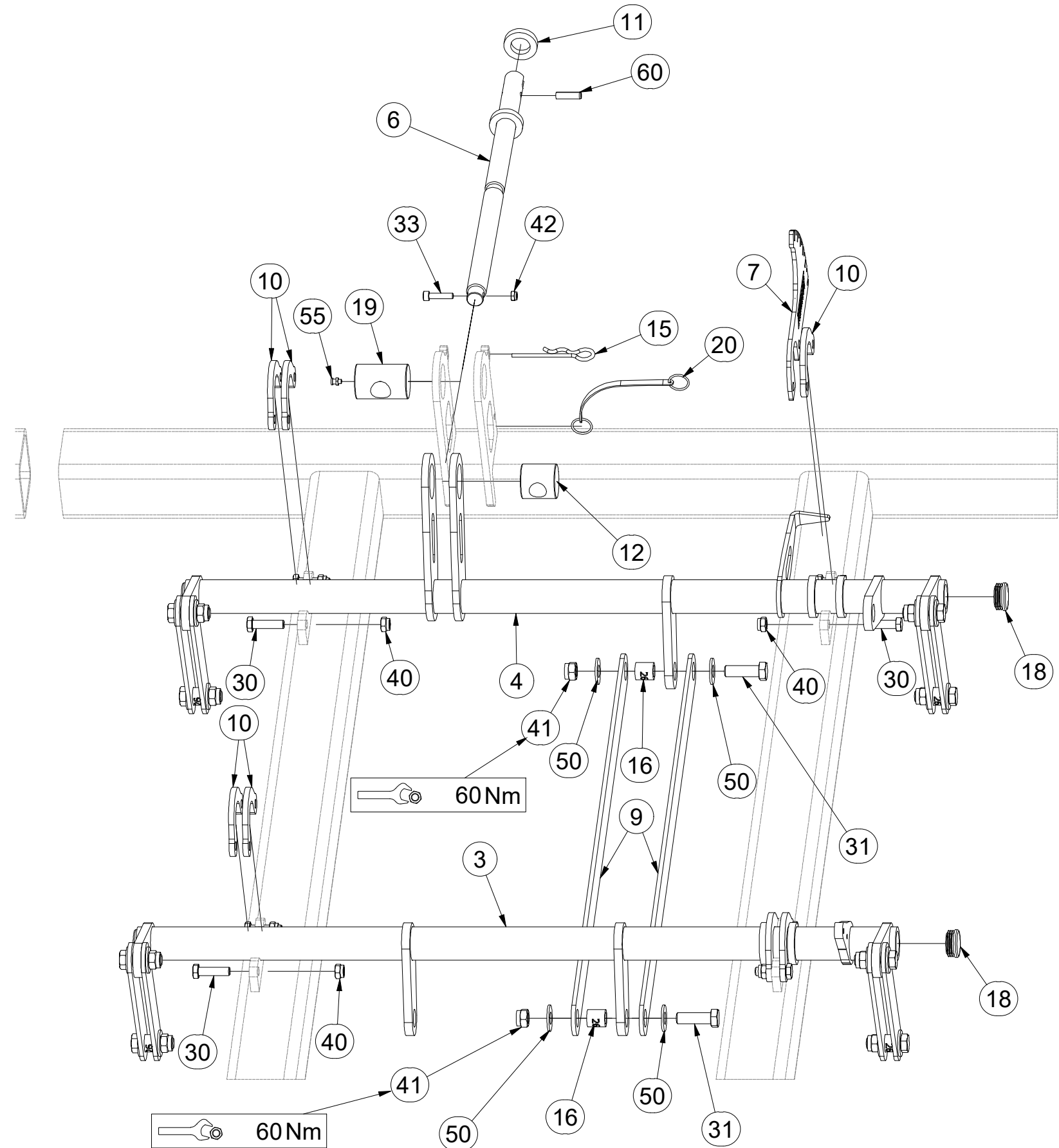
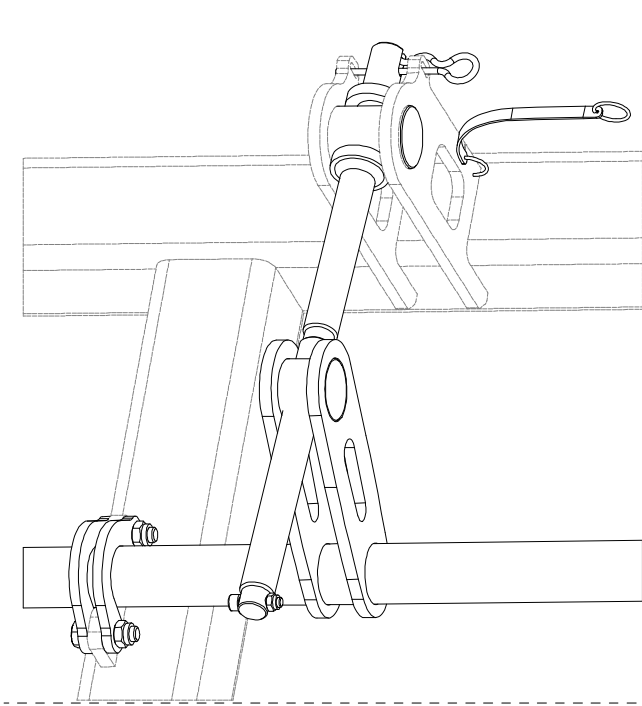
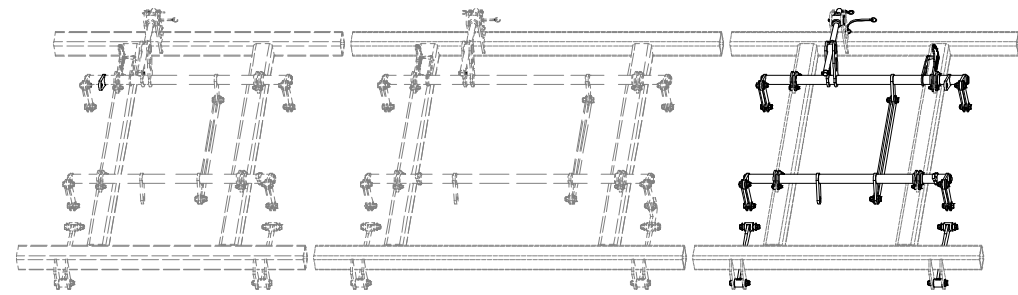

| Pos. | Part Number | Pcs. | Pos. | Part Number | Pcs. |
|------|-------------|------|------|-------------|------|
| 3 | VZ00007789 | 2 | 19 | 9002114 | 3 |
| 4 | VZ00021523 | 1 | 20 | m12467 | 3 |
| 6 | 4024250 | 3 | 30 | m06077 | 24 |
| 7 | 4023896 | 3 | 31 | m04355 | 30 |
| 9 | 4005334 | 6 | 33 | m09464 | 3 |
| 10 | 4005332 | 21 | 40 | m04301 | 24 |
| 11 | 9002560 | 3 | 41 | m03683 | 42 |
| 12 | 4005340 | 3 | 42 | m04503 | 3 |
| 15 | m09988 | 3 | 50 | m05651 | 84 |
| 16 | 4002265 | 30 | 55 | m10451 | 3 |
| 18 | m10130 | 12 | 60 | m10736 | 3 |

☉ SADA RADLIC

☉ SCHARSATZ

☉ KIT DE SOCS

3002834

☉ SET OF PLOUGHSHARES

☉ КОМПЛЕКТ ЛАП

☉ ZESTAW REDLIC

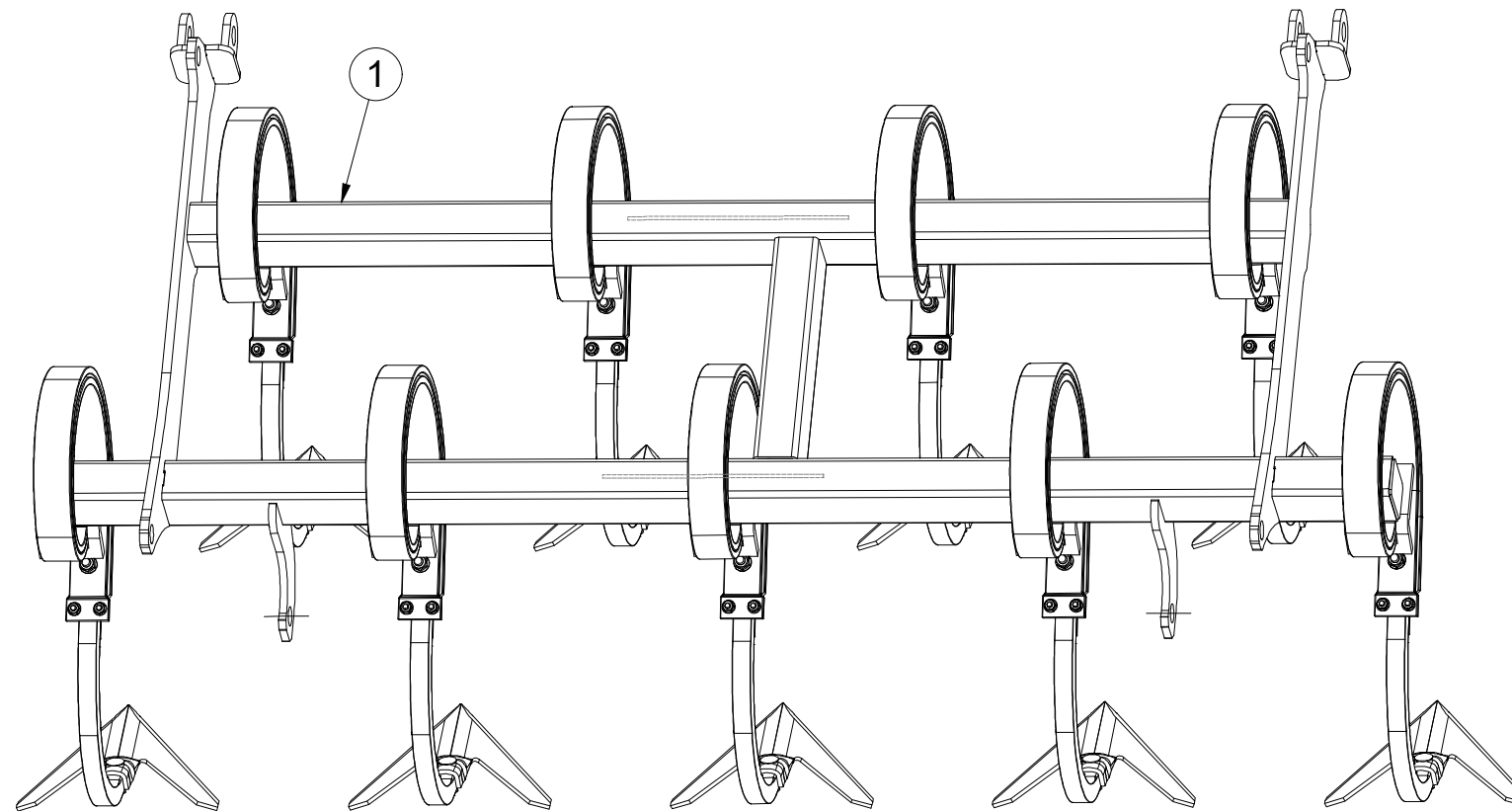
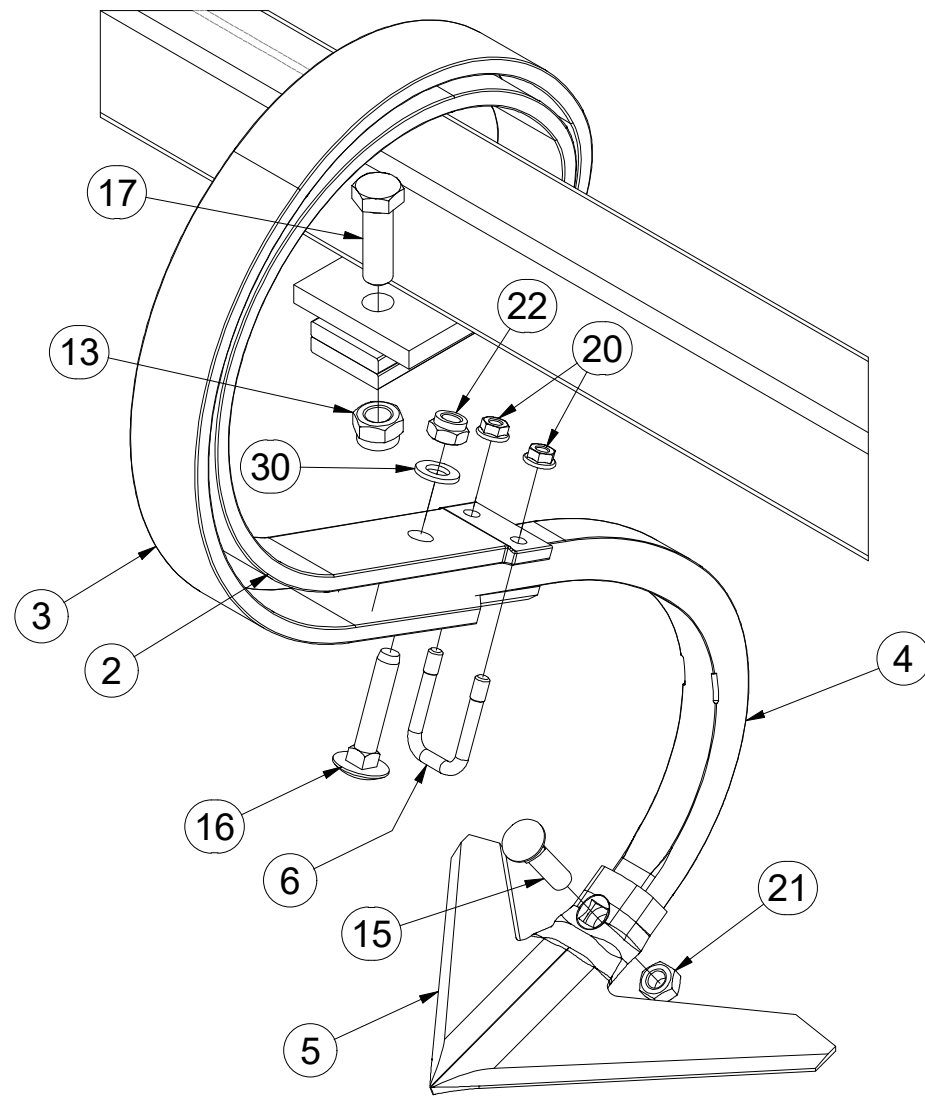
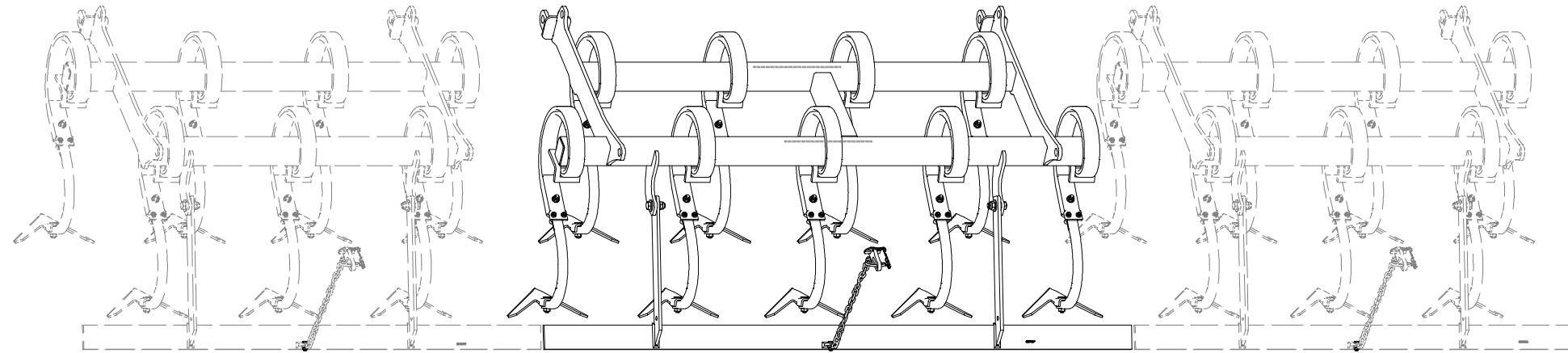

| Pos. | Part Number | Pcs. |
|------|-------------|------|
| 1 | 3010347 | 1 |
| 2 | 3000300 | 9 |
| 3 | 3000301 | 9 |
| 4 | 3002818 | 9 |
| 5 | 3000236-KOO | 9 |
| 6 | m09995 | 9 |
| 13 | m03683 | 9 |
| 15 | m10440 | 9 |
| 16 | m11600 | 9 |
| 17 | m04355 | 9 |
| 20 | m06156 | 18 |
| 21 | m10439 | 9 |
| 22 | m04301 | 9 |
| 30 | m01214 | 9 |

Ⓒ CZ SADA RADLIC

Ⓓ D SCHARSATZ

Ⓕ F KIT DE SOCS

3012642

Ⓖ GB SET OF PLOUGHSHARES

Ⓡ RU КОМПЛЕКТ ЛАП

Ⓟ PL ZESTAW REDLIC

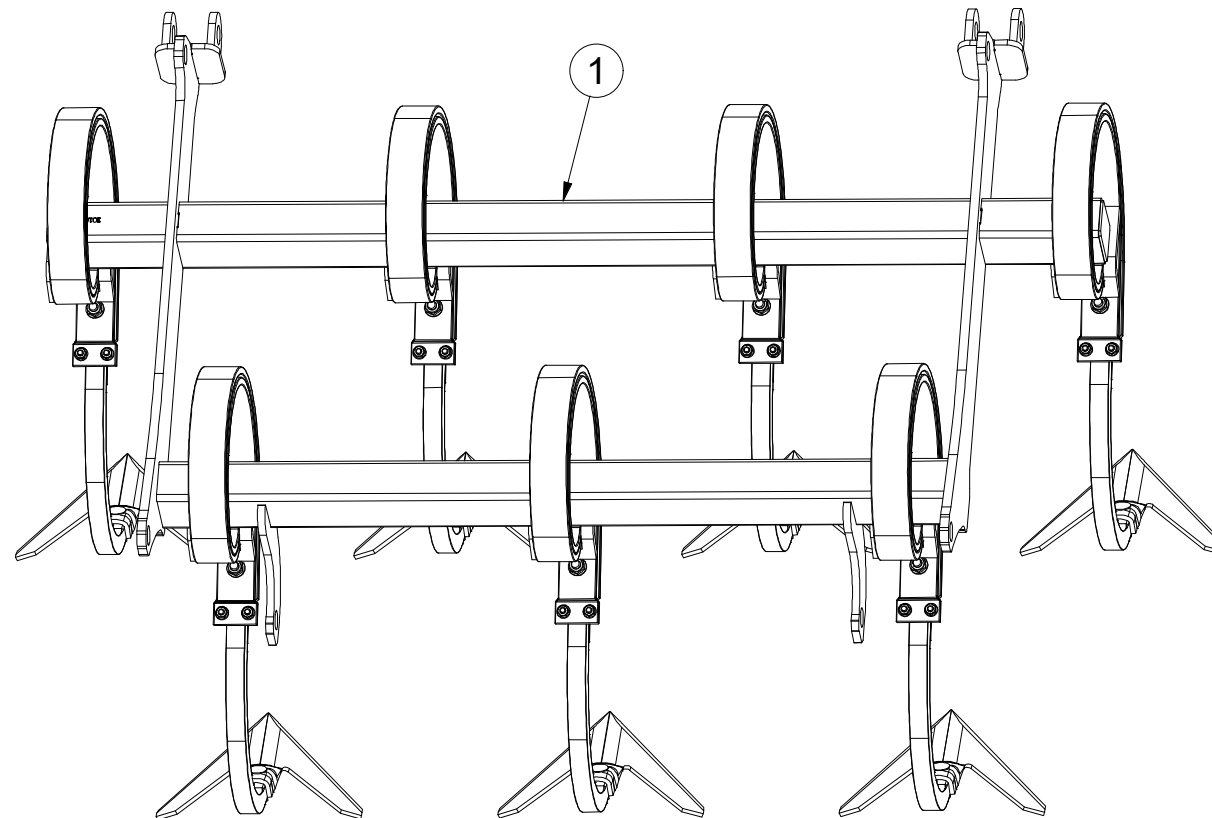
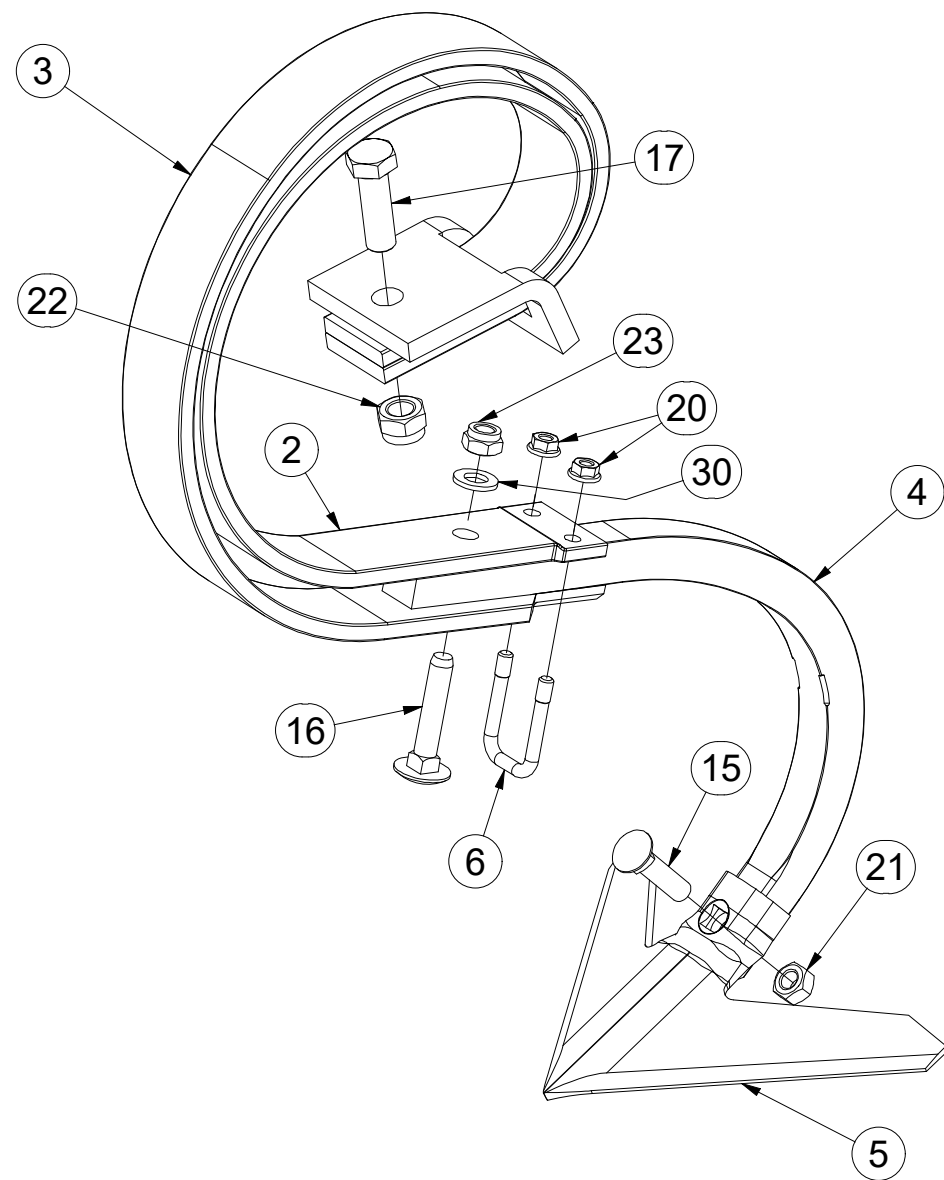
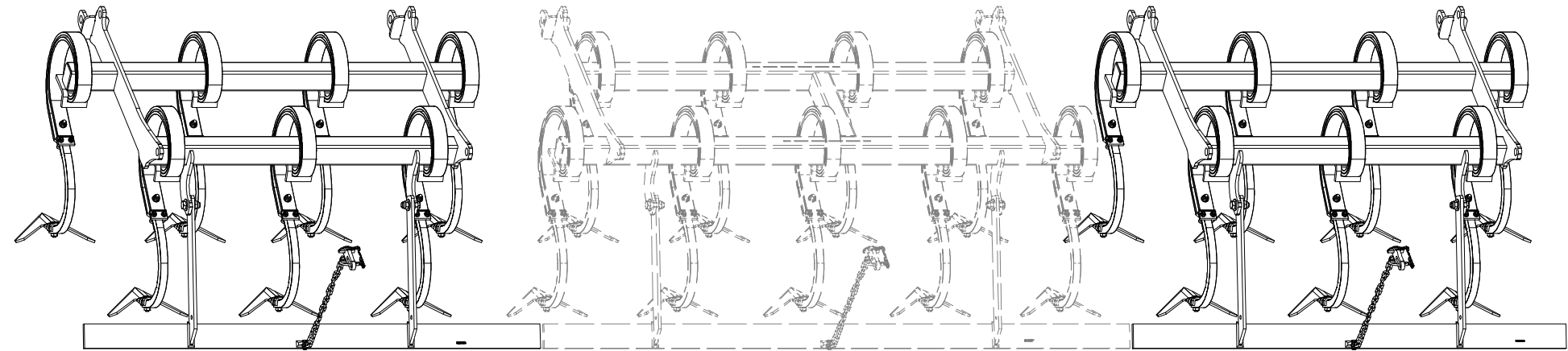

| Pos. | Part Number | Pcs. |
|------|-------------|------|
| 1 | 3010340 | 1 |
| 2 | 3000300 | 7 |
| 3 | 3000301 | 7 |
| 4 | 3002818 | 7 |
| 5 | 3000236-KOO | 7 |
| 6 | m09995 | 7 |
| 15 | m10440 | 7 |
| 16 | m11600 | 7 |
| 17 | m04355 | 7 |
| 20 | m06156 | 14 |
| 21 | m10439 | 7 |
| 22 | m03683 | 7 |
| 23 | m04301 | 7 |
| 30 | m01214 | 7 |

- Ⓒ SADA ZADNÍCH VÁLCŮ
- Ⓓ SATZ HINTERE WALZEN
- Ⓕ KIT DE ROULEAUX ARRIÈRE

- Ⓖ SET OF REAR ROLLERS
- Ⓡ КОМПЛЕКТ ЗАДНИХ КАТКОВ
- Ⓟ ZESTAW TYLNYCH WAŁÓW



VZ00018651

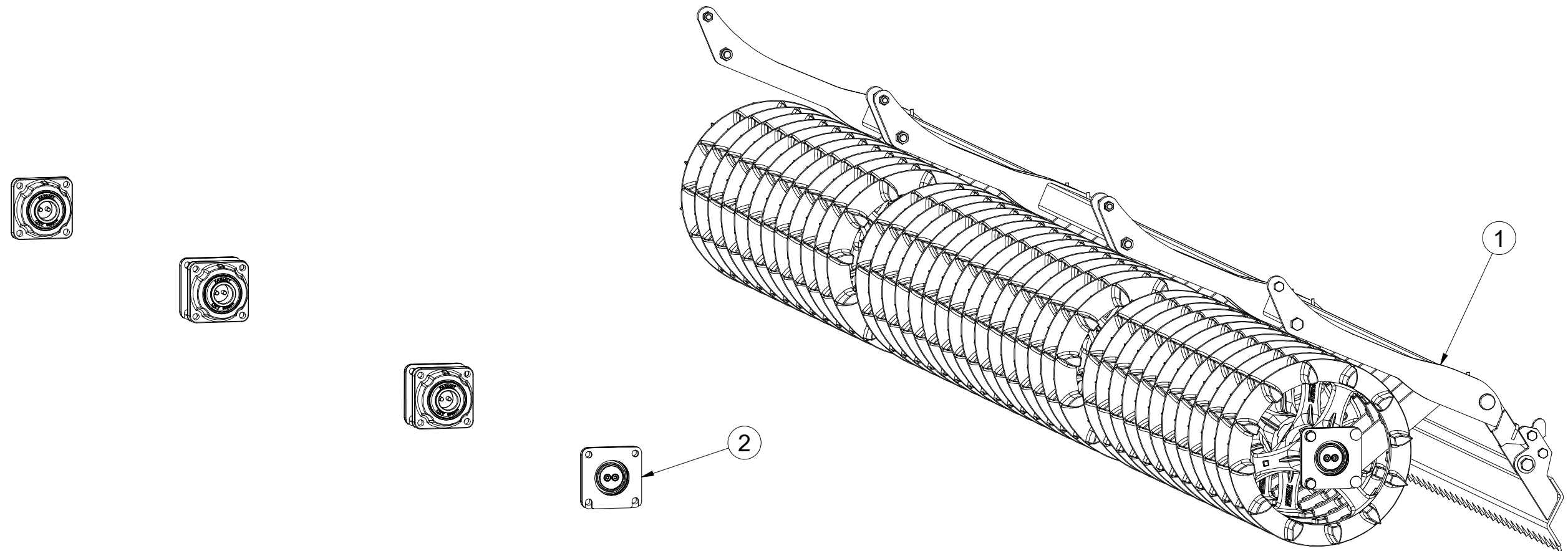

| Pos. | Part Number | Pcs. |
|------|-------------|------|
| 1 | 3011957 | 1 |
| 2 | VZ00012425 | 1 |

- ⒸZ SADA ZADNÍCH VÁLCŮ
- Ⓓ SATZ HINTERE WALZEN
- Ⓕ KIT DE ROULEAUX ARRIÈRE

- ⒼB SET OF REAR ROLLERS
- ⒲U КОМПЛЕКТ ЗАДНИХ КАТКОВ
- ⒼL ZESTAW TYLNYCH WAŁÓW



3011957

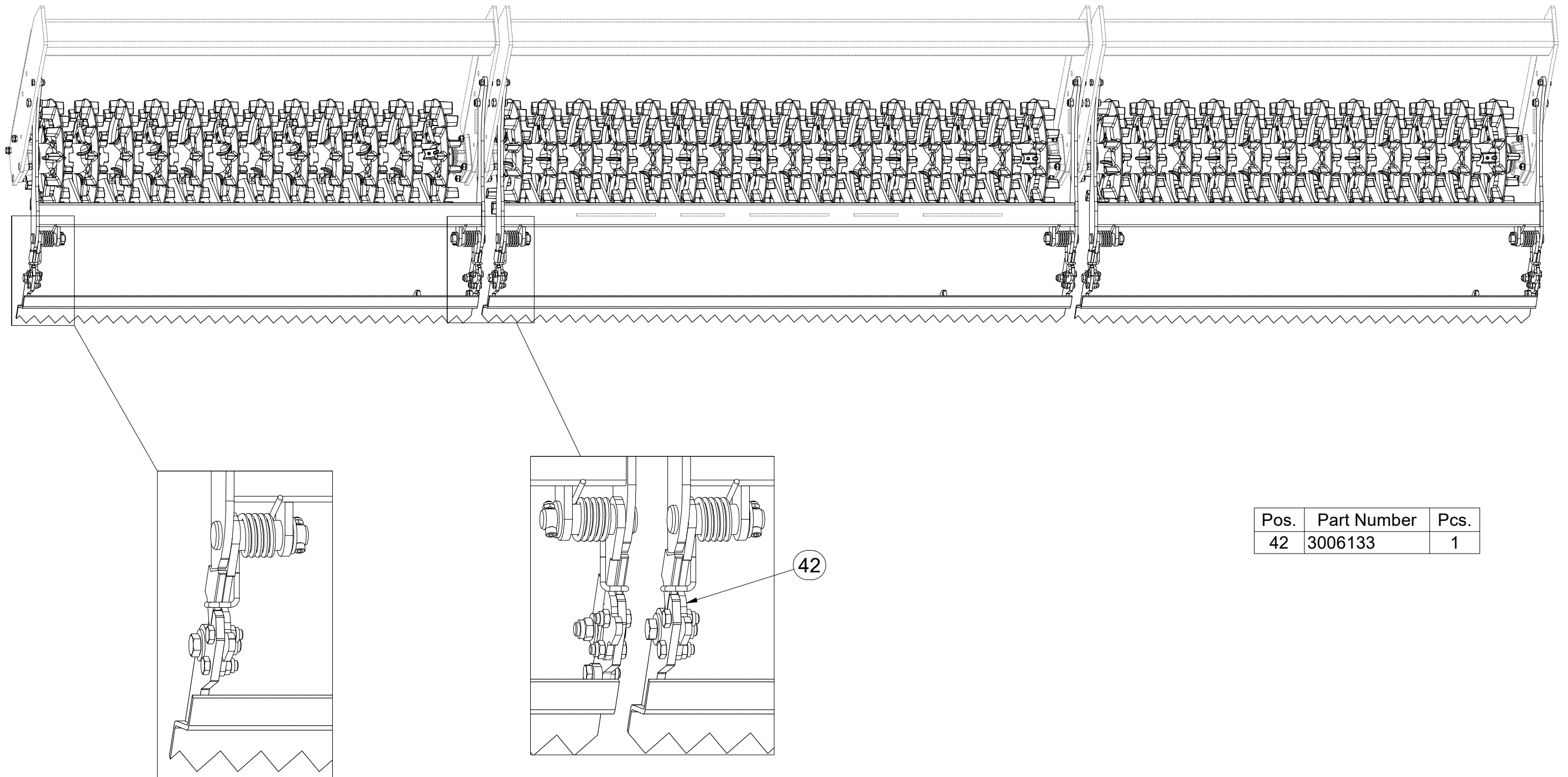

| Pos. | Part Number | Pcs. |
|------|-------------|------|
| 42 | 3006133 | 1 |

(CZ) SADA ZADNÍCH VÁLCŮ
 (D) SATZ HINTERE WALZEN
 (F) KIT DE ROULEAUX ARRIÈRE

(GB) SET OF REAR ROLLERS
 (RU) КОМПЛЕКТ ЗАДНИХ КАТКОВ
 (PL) ZESTAW TYLNYCH WAŁÓW



3011957

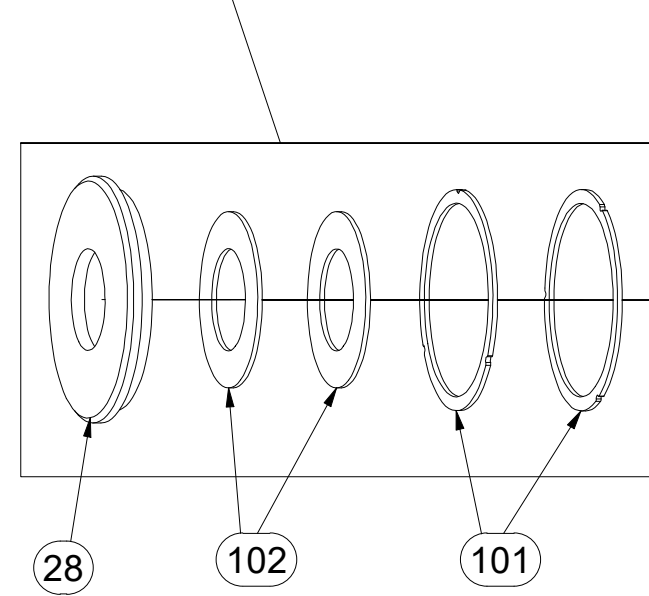
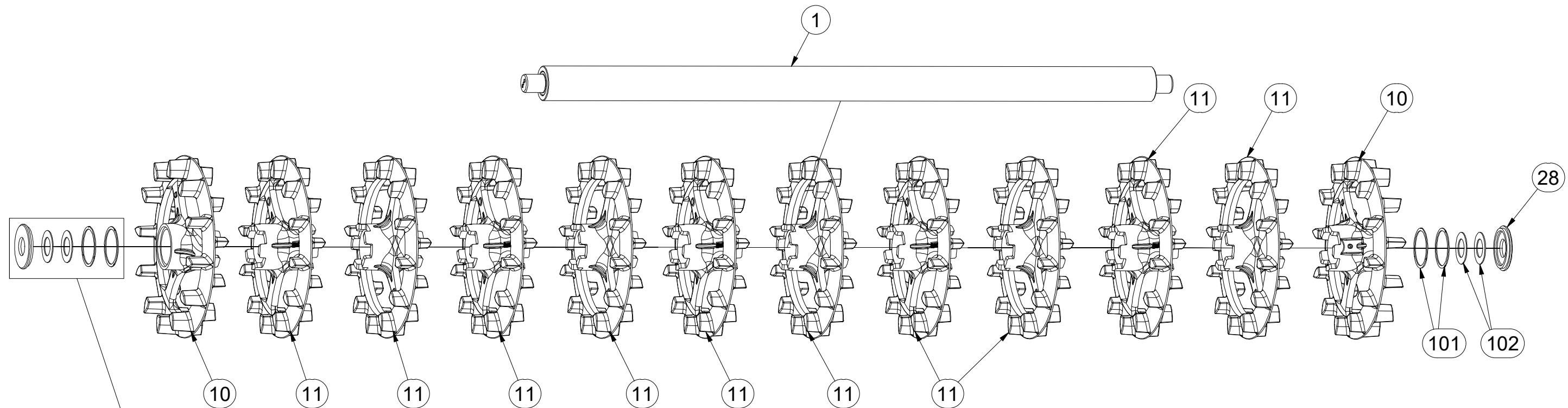
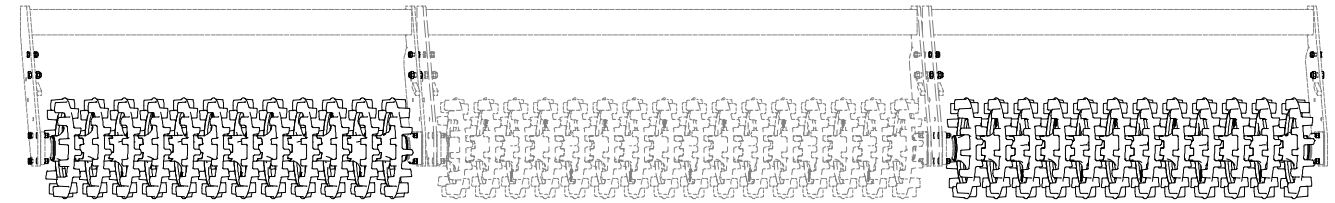

| Pos. | Part Number | Pcs. |
|------|-------------|------|
| 1 | 3011835 | 2 |
| 10 | VZ00014125 | 4 |
| 11 | VZ00011865 | 34 |
| 28 | 4024061 | 4 |
| 57 | m13958 | 12 |
| 101 | 4010992 | 8 |
| 102 | 4024556 | 12 |

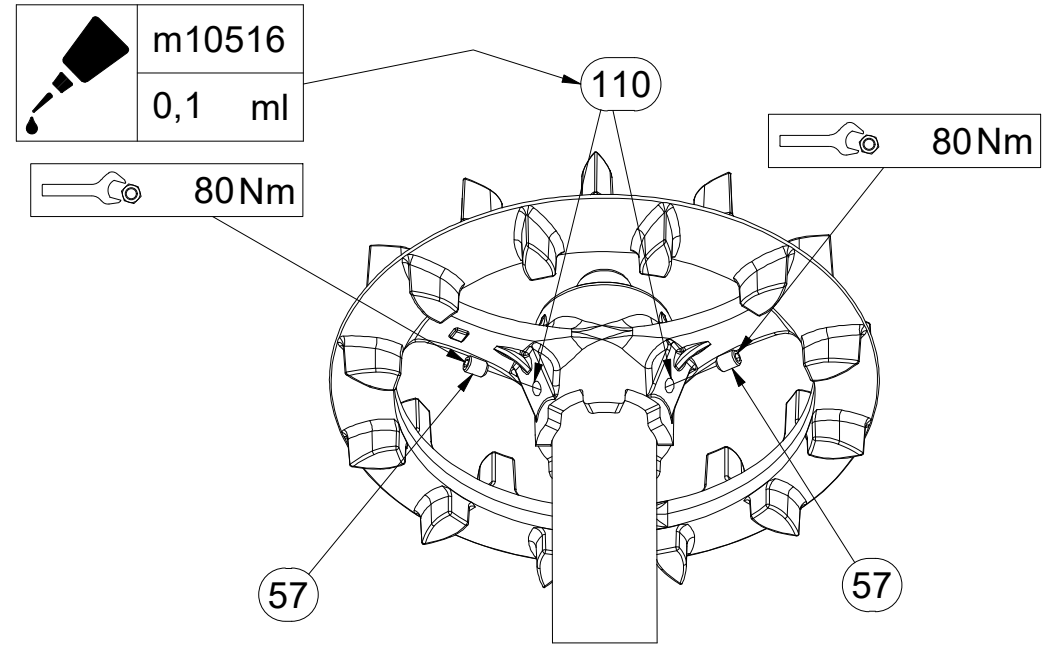

- ⒸZ SADA ZADNÍCH VÁLČŮ
- Ⓓ SATZ HINTERE WALZEN
- Ⓕ KIT DE ROULEAUX ARRIÈRE

- ⒸB SET OF REAR ROLLERS
- ⒸU КОМПЛЕКТ ЗАДНИХ КАТКОВ
- ⒸL ZESTAW TYLNYCH WAŁÓW



3011957

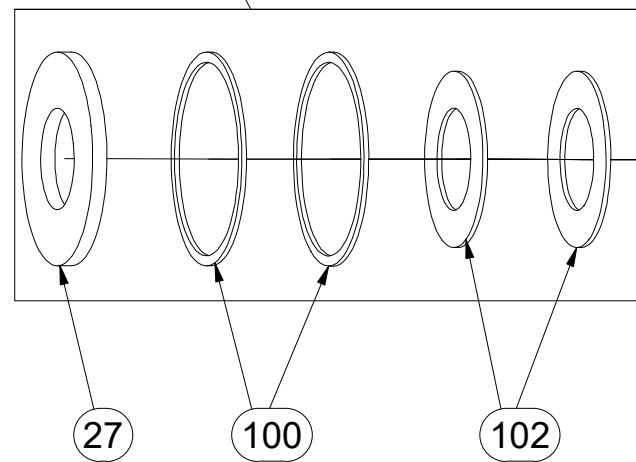
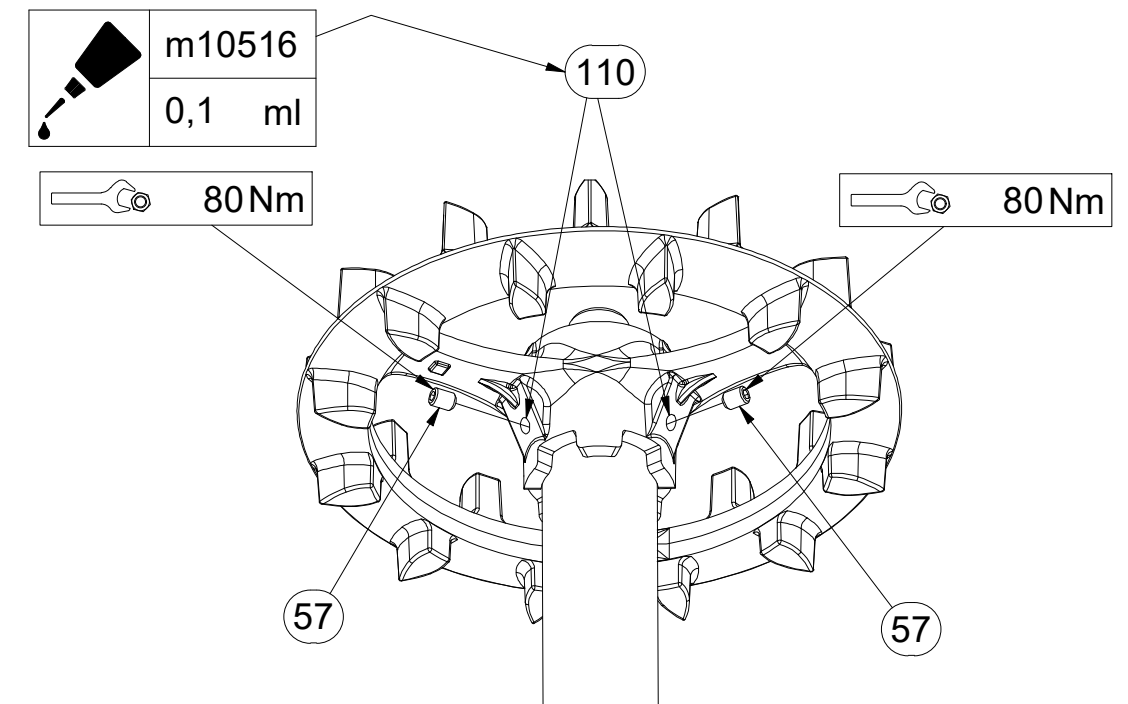
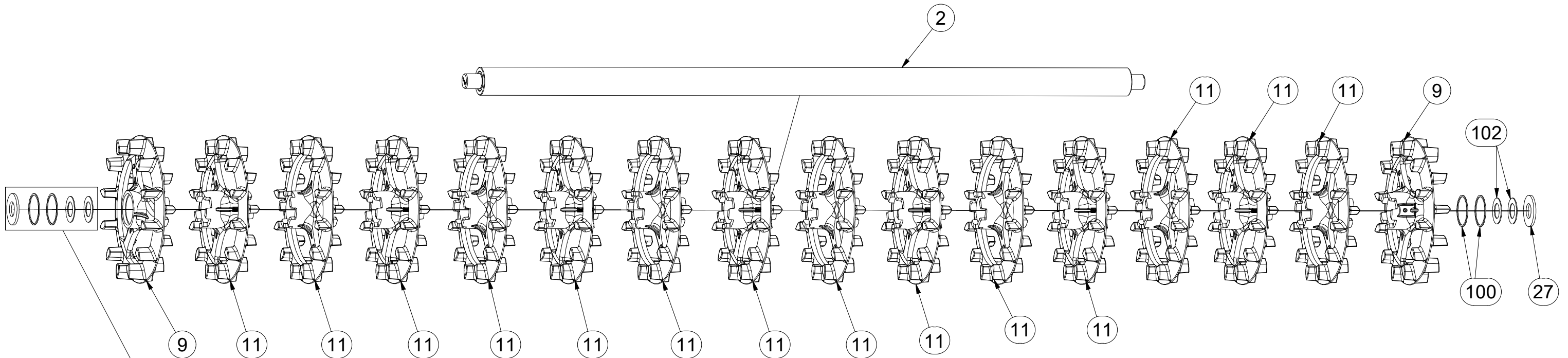
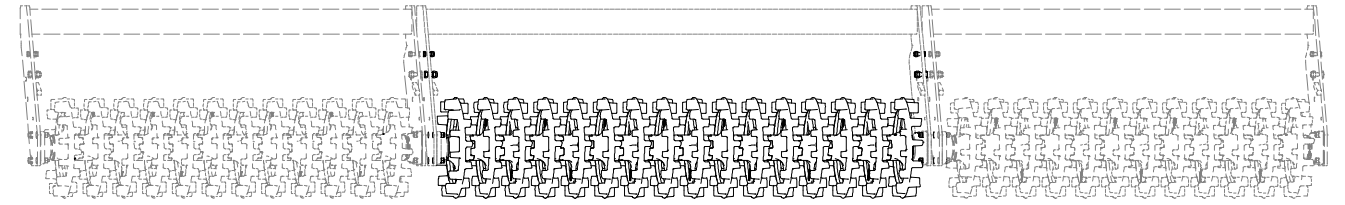

| Pos. | Part Number | Pcs. |
|------|-------------|------|
| 2 | 3011293 | 1 |
| 9 | VZ00011862 | 2 |
| 11 | VZ00011865 | 34 |
| 27 | 4016995 | 2 |
| 57 | m13958 | 12 |
| 100 | 4010015 | 4 |
| 102 | 4024556 | 12 |
| 110 | m10516 | 1,2 |

- ⒸZ SADA ZADNÍCH VÁLCŮ
- Ⓓ SATZ HINTERE WALZEN
- Ⓕ KIT DE ROULEAUX ARRIÈRE

- ⒼB SET OF REAR ROLLERS
- ⒺU КОМПЛЕКТ ЗАДНИХ КАТКОВ
- ⒺL ZESTAW TYLNYCH WAŁÓW



3011957

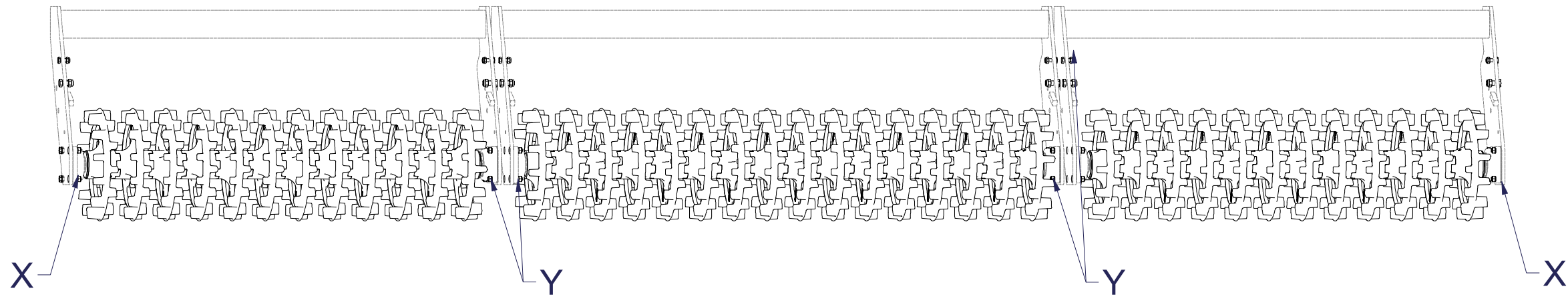

| Pos. | Part Number | Pcs. |
|------|-------------|------|
| 52 | m03519 | 20 |
| 53 | m04412 | 4 |
| 60 | m01305 | 24 |
| 71 | m03988 | 24 |
| 72 | m17741 | 4 |

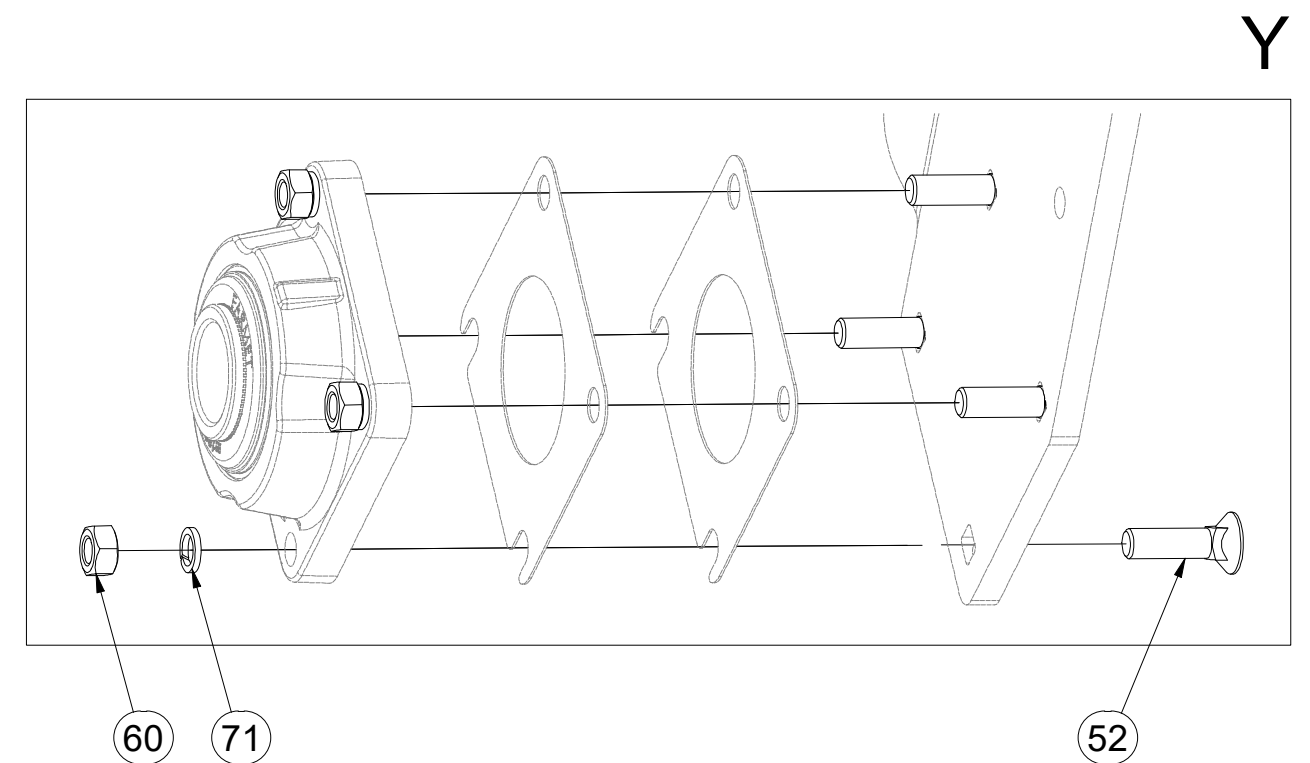
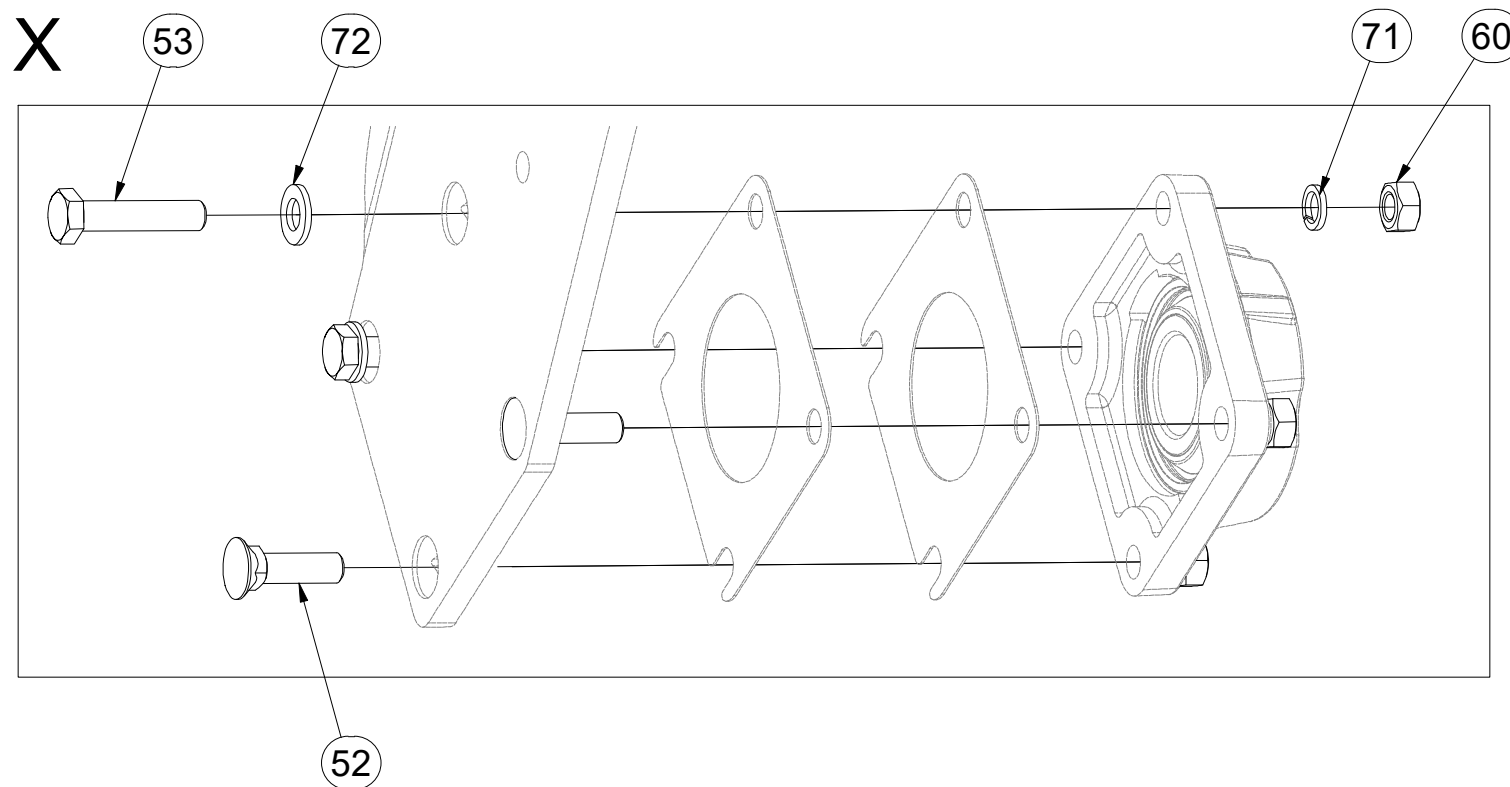

- ⒸZ SADA ZADNÍCH VÁLČŮ
- Ⓓ SATZ HINTERE WALZEN
- Ⓕ KIT DE ROULEAUX ARRIÈRE

- ⒼB SET OF REAR ROLLERS
- ⒹU КОМПЛЕКТ ЗАДНИХ КАТКОВ
- ⒹL ZESTAW TYLNYCH WAŁÓW



3011957

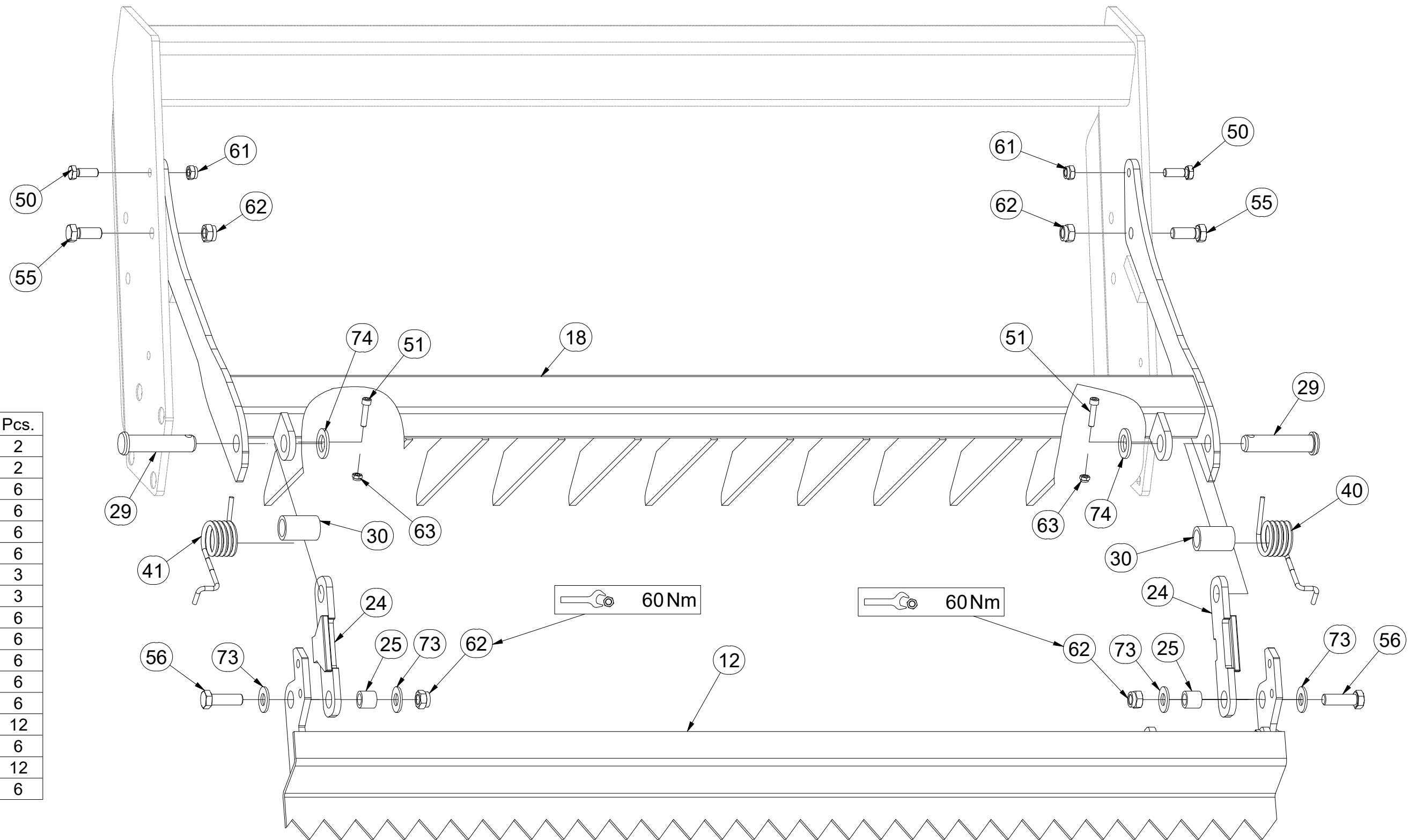
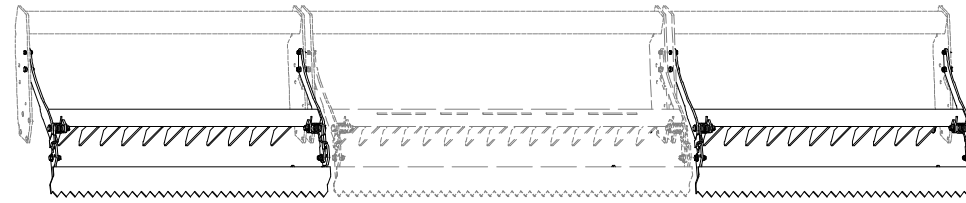

| Pos. | Part Number | Pcs. |
|------|-------------|------|
| 12 | VZ00018655 | 2 |
| 18 | 3004899 | 2 |
| 24 | 4024903 | 6 |
| 25 | 4022223 | 6 |
| 29 | 4015778 | 6 |
| 30 | 9002979 | 6 |
| 40 | m12303 | 3 |
| 41 | m12304 | 3 |
| 50 | m04343 | 6 |
| 51 | m09464 | 6 |
| 55 | m01129 | 6 |
| 56 | m04355 | 6 |
| 61 | m04301 | 6 |
| 62 | m03683 | 12 |
| 63 | m04503 | 6 |
| 73 | m05651 | 12 |
| 74 | m14028 | 6 |

ⒸZ SADA ZADNÍCH VÁLČŮ

Ⓓ SATZ HINTERE WALZEN

Ⓕ KIT DE ROULEAUX ARRIÈRE

ⒼB SET OF REAR ROLLERS

ⒺU КОМПЛЕКТ ЗАДНИХ КАТКОВ

ⒼL ZESTAW TYLNYCH WAŁÓW



3011957

| Pos. | Part Number | Pcs. | Pos. | Part Number | Pcs. | Pos. | Part Number | Pcs. | Pos. | Part Number | Pcs. |
|------|-------------|------|------|-------------|------|------|-------------|------|------|-------------|------|
| 13 | VZ00018653 | 1 | 30 | 9002979 | 6 | 55 | m01129 | 6 | 73 | m05651 | 12 |
| 19 | 3004896 | 1 | 40 | m12303 | 3 | 56 | m04355 | 6 | 74 | m14028 | 6 |
| 24 | 4024903 | 6 | 41 | m12304 | 3 | 61 | m04301 | 6 | | | |
| 25 | 4022223 | 6 | 50 | m04343 | 6 | 62 | m03683 | 12 | | | |
| 29 | 4015778 | 6 | 51 | m09464 | 6 | 63 | m04503 | 6 | | | |

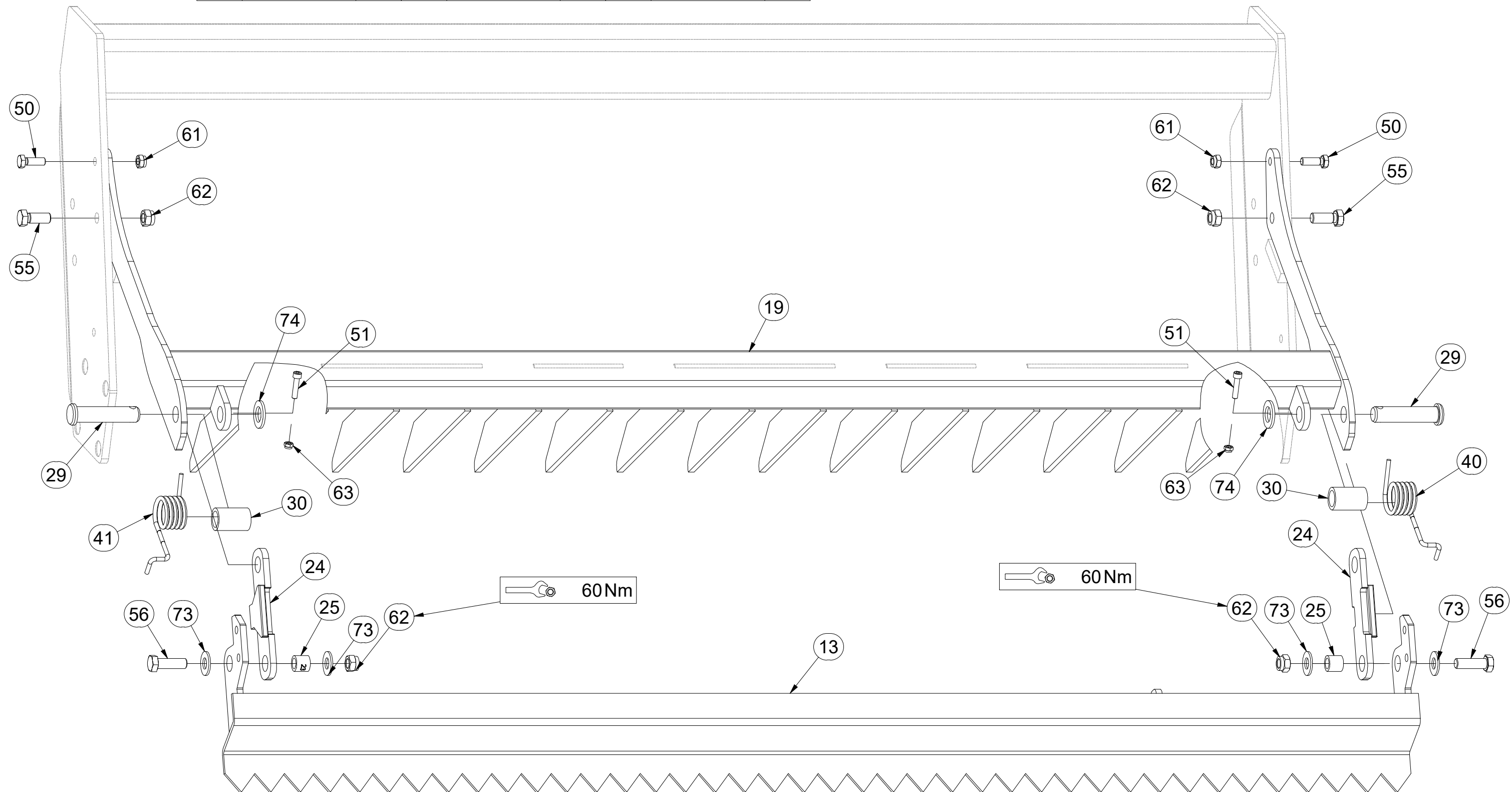
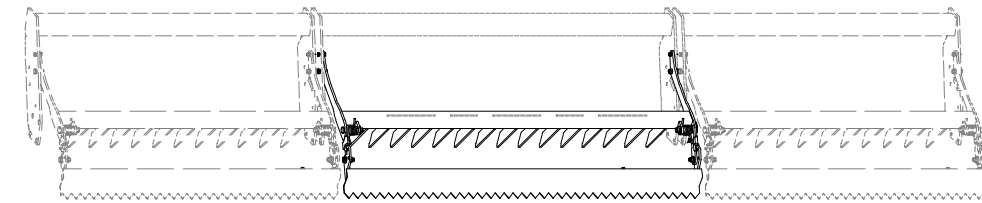

- ⒸZ SADA ZADNÍCH VÁLČŮ
- Ⓓ SATZ HINTERE WALZEN
- Ⓕ KIT DE ROULEAUX ARRIÈRE

- ⒼB SET OF REAR ROLLERS
- ⒹU КОМПЛЕКТ ЗАДНИХ КАТКОВ
- ⒹL ZESTAW TYLNYCH WAŁÓW



3011957

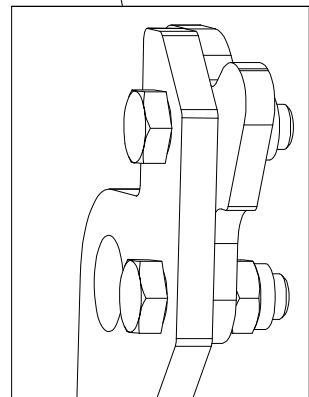
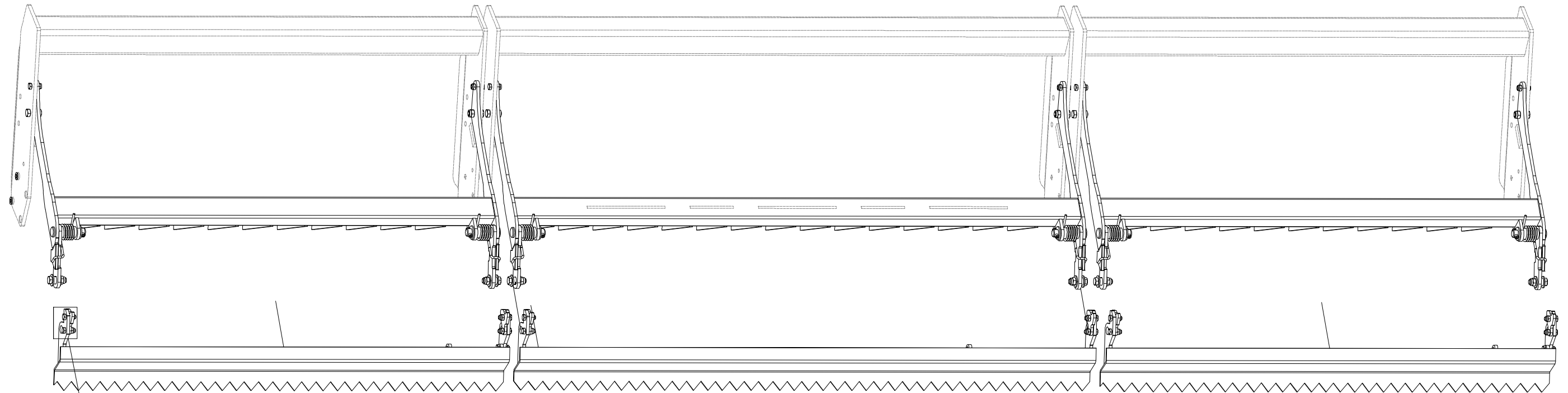

| Pos. | Part Number | Pcs. |
|------|-------------|------|
| 42 | 3006133 | 1 |

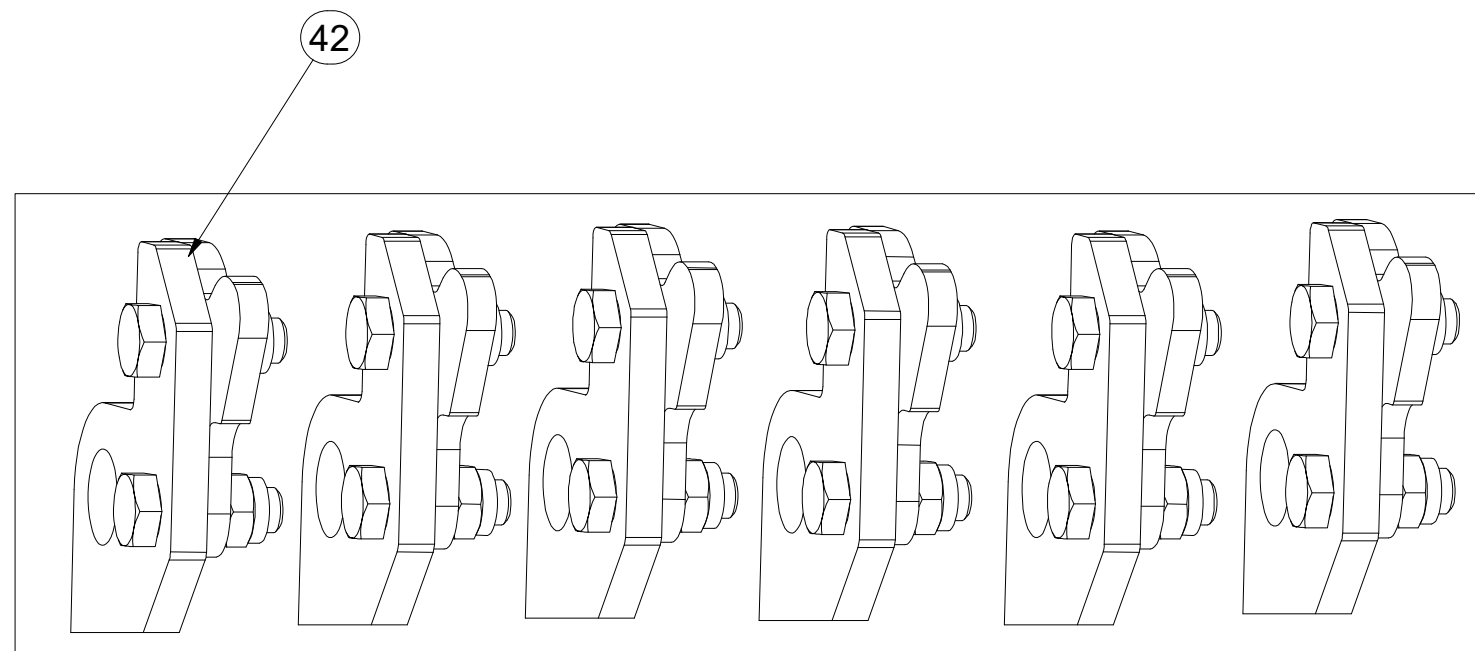

Ⓒ SADA FINIŠ SMYKŮ

Ⓓ SATZ FINISH-SCHLEPPE

Ⓕ KIT DE GUIDES DE FINITION

Ⓖ SET OF FINISH LEVELLERS

Ⓡ КОМПЛЕКТ ФИНИШНЫХ БОРОН

Ⓟ ZESTAW WŁÓK FINISH



VZ00018655

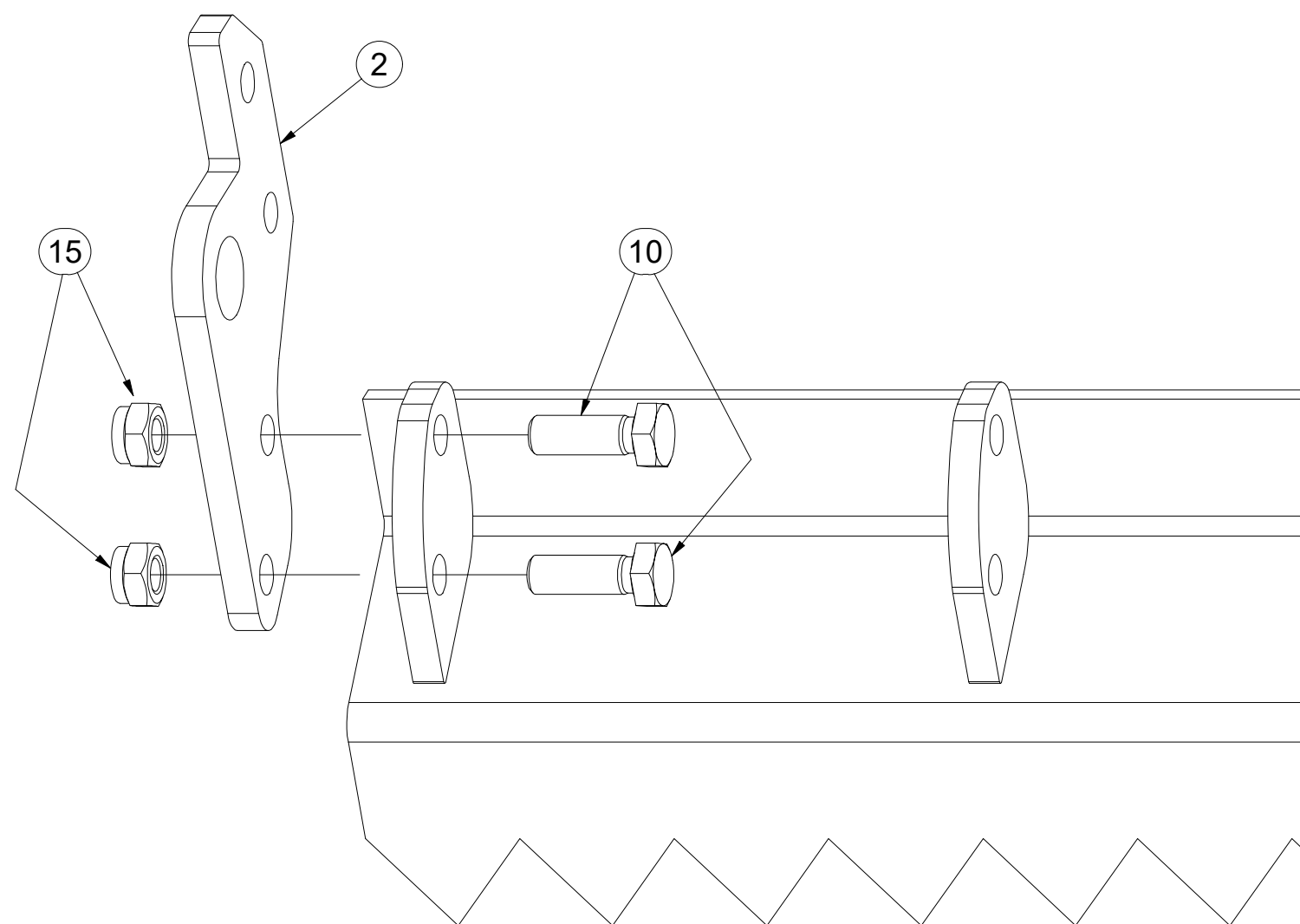
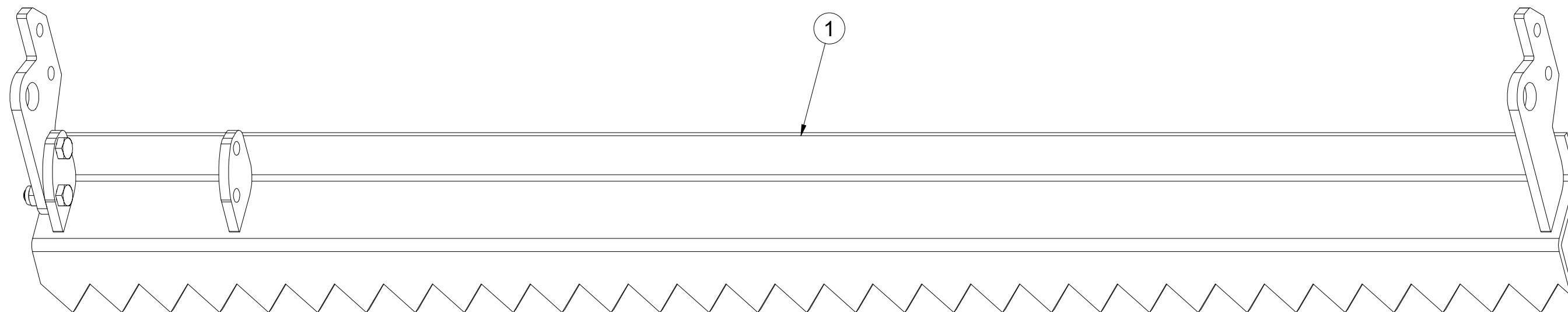

| Pos. | Part Number | Pcs. |
|------|-------------|------|
| 1 | VZ00018652 | 1 |
| 2 | VZ00014941 | 1 |
| 10 | m04343 | 2 |
| 15 | m04301 | 2 |

ⒸZ SADA DORAZŮ ZADNÍCH SMYKŮ

Ⓓ ANSCHLAGSATZ FÜR HINTERE ACKERSCHLEPPEN

Ⓕ KIT DE BUTÉES DES NIVELEURS ARRIÈRE

3006133

ⒼB SET OF REAR LEVELLING BAR STOPS

ⒺU КОМПЛЕКТ УПОРОВ ЗАДНИХ БОРОН

ⒽL ZESTAW DOCISKÓW TYLNYCH WŁÓK

Farmet

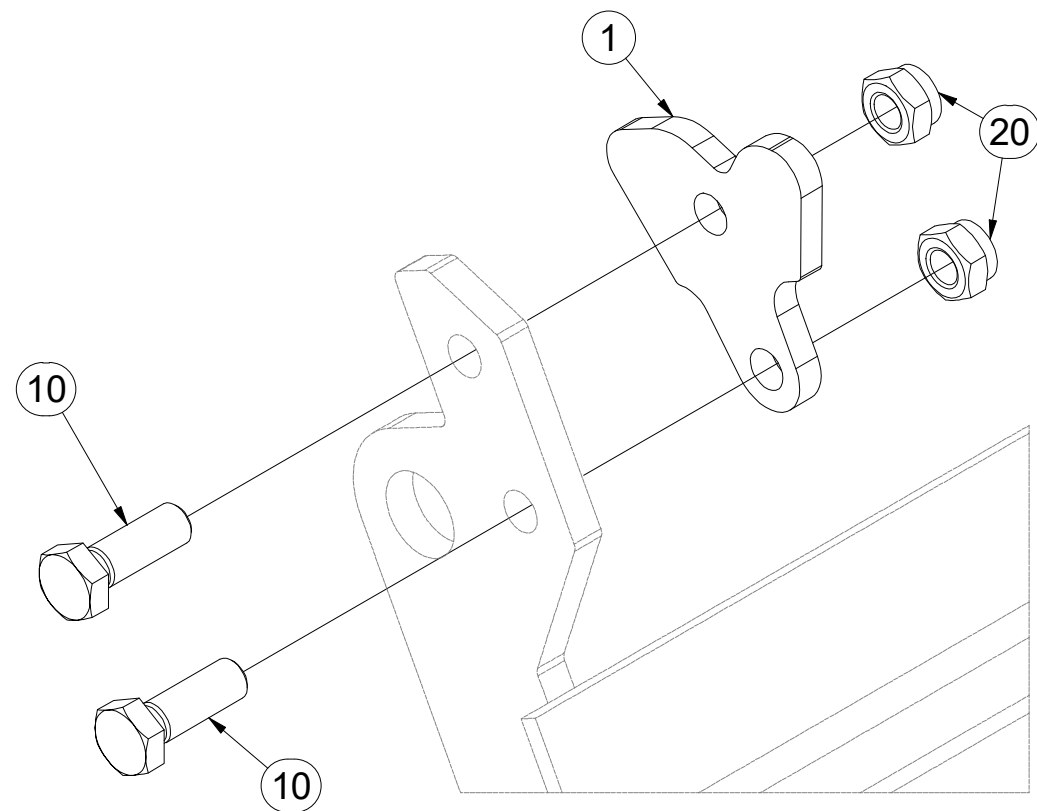
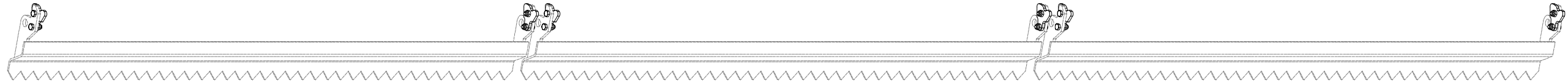

| Pos. | Part Number | Pcs. |
|------|-------------|------|
| 1 | 4013331 | 6 |
| 10 | m04343 | 12 |
| 20 | m04301 | 12 |

- Ⓒ SADA LOŽISEK
- Ⓓ SATZ LAGER
- Ⓕ KIT DE ROULEMENTS

- Ⓖ SET OF BEARINGS
- Ⓡ КОМПЛЕКТ ПОДШИПНИКОВ
- Ⓟ ZESTAW ŁOŻYSK



VZ00012425

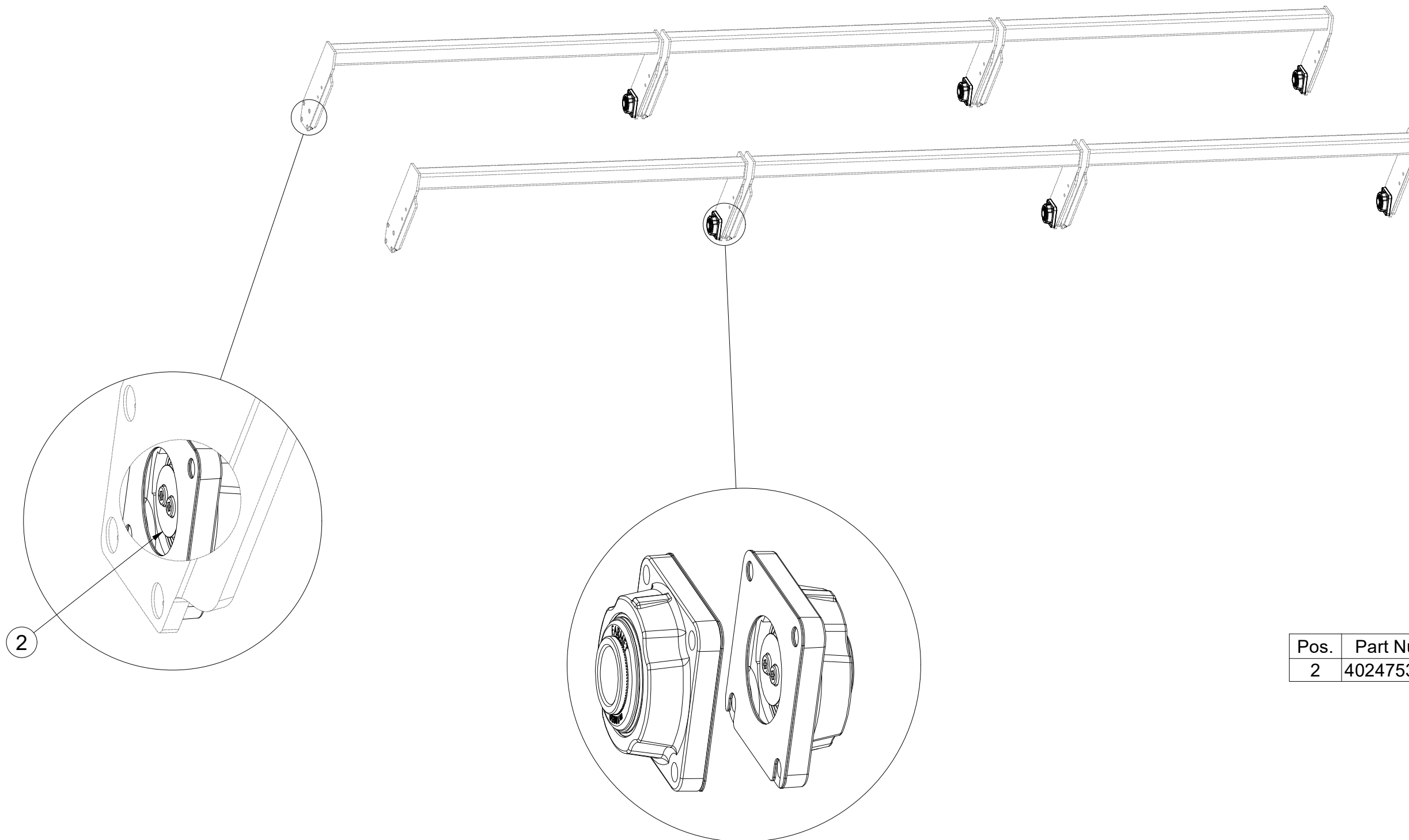

| Pos. | Part Number | Pcs. |
|------|-------------|------|
| 2 | 4024753 | 12 |

(CZ) SADA LOŽISEK
 (D) SATZ LAGER
 (F) KIT DE ROULEMENTS

(GB) SET OF BEARINGS
 (RU) КОМПЛЕКТ ПОДШИПНИКОВ
 (PL) ZESTAW ŁOŻYSK



VZ00012425

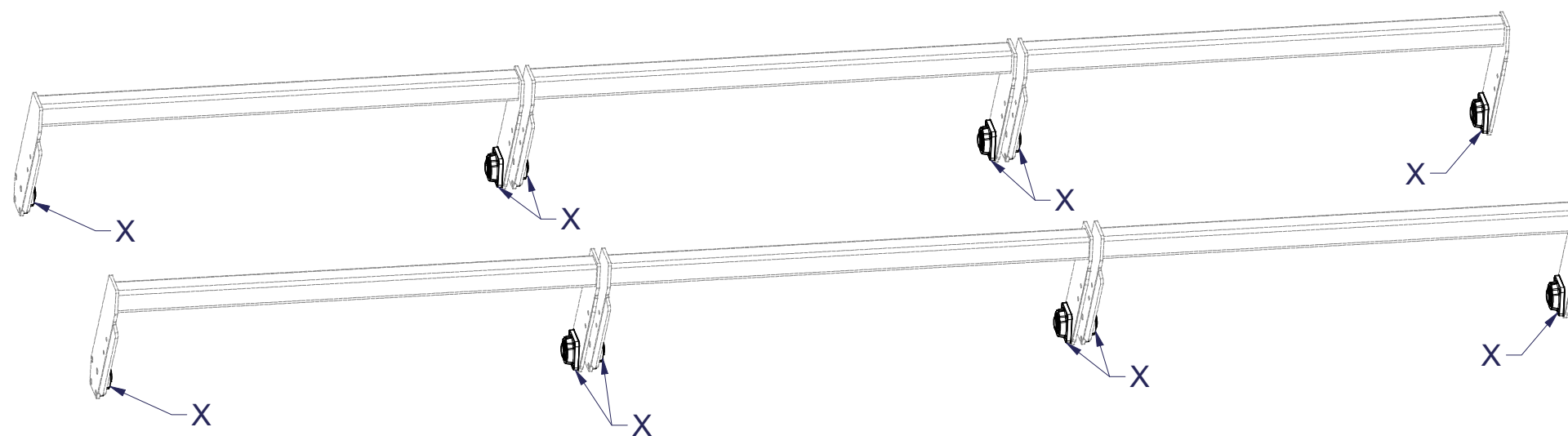

X

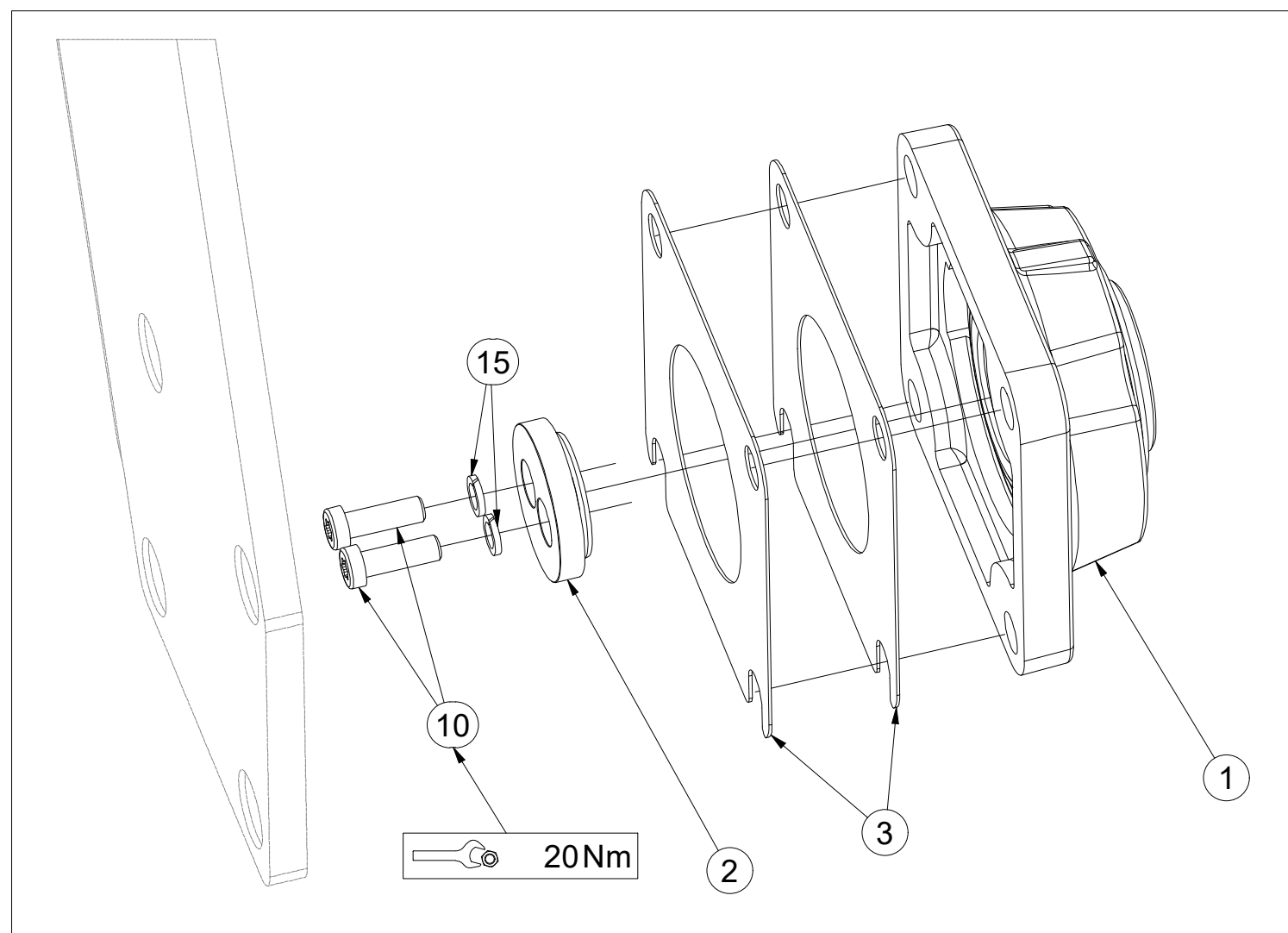

| Pos. | Part Number | Pcs. |
|------|-------------|------|
| 1 | m18650 | 12 |
| 2 | 4024753 | 12 |
| 3 | 4016809 | 24 |
| 10 | m18858 | 24 |
| 15 | m01202 | 24 |

Ⓒ SADA NÁPRAVY

Ⓓ SATZ AUFHÄNGUNG

Ⓕ KIT DE L'ESSIEU

Ⓖ AXLE SET

Ⓡ КОМПЛЕКТ ОСИ КОЛЁС

Ⓢ ZESTAW OSI



3012415

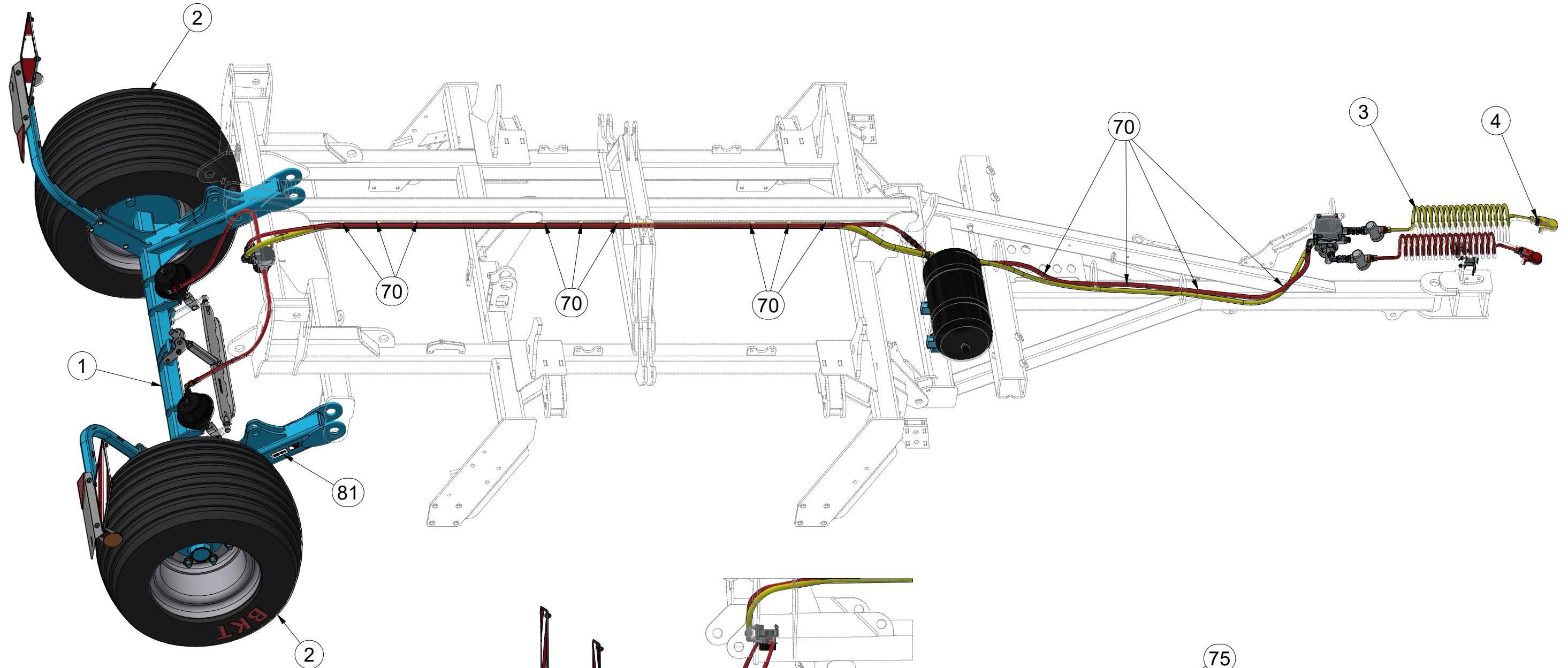

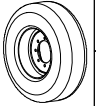
| | |
|---|---------------|
|  | 280 kPa |
| | M20x1,5-343Nm |

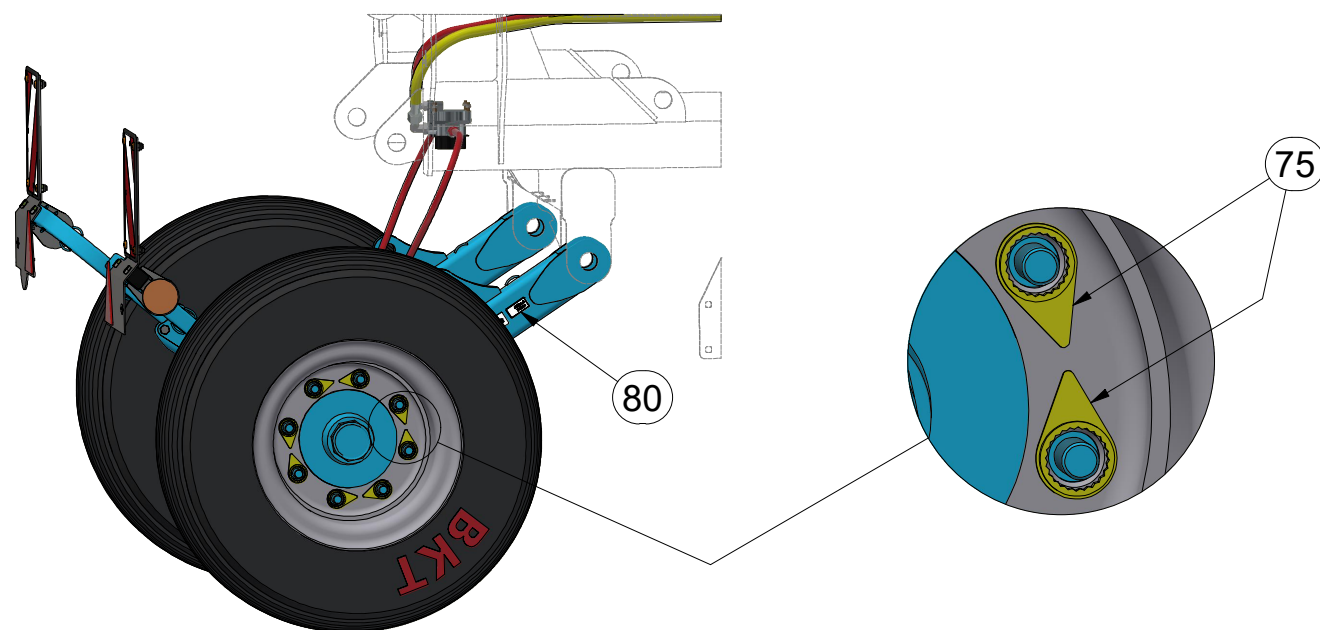

| Pos. | Part Number | Pcs. |
|------|-------------|------|
| 1 | 3012421 | 1 |
| 2 | m21353 | 2 |
| 3 | m18910 | 1 |
| 4 | m19041 | 1 |
| 70 | m05566 | 30 |
| 75 | m19658 | 16 |
| 80 | m19731 | 2 |
| 81 | m21945 | 2 |

Ⓒ SADA NÁPRAVY

Ⓓ SATZ AUFHÄNGUNG

Ⓕ KIT DE L'ESSIEU

3012415

Ⓖ AXLE SET

Ⓡ КОМПЛЕКТ ОСИ КОЛЁС

Ⓢ ZESTAW OSI

Farmet

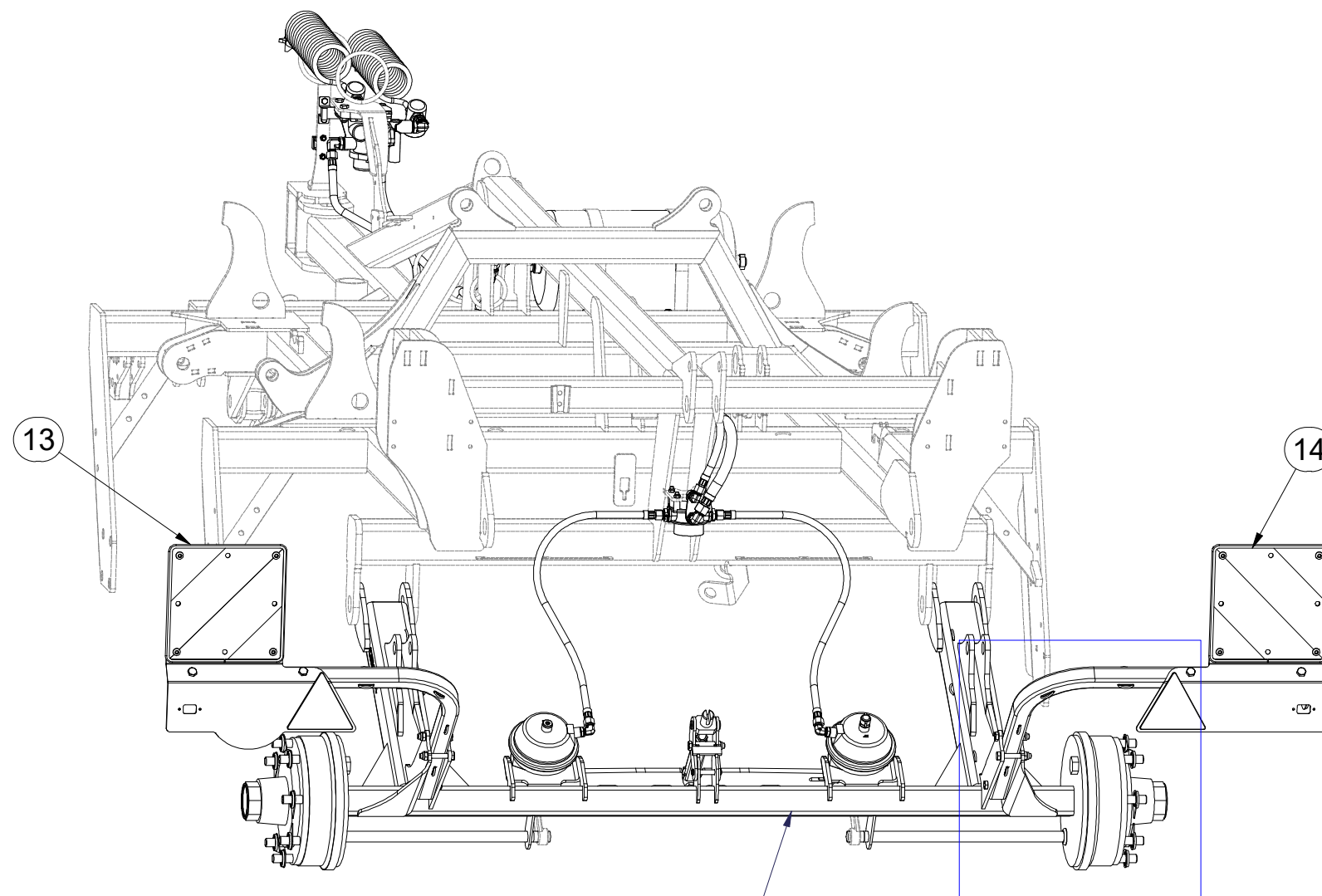
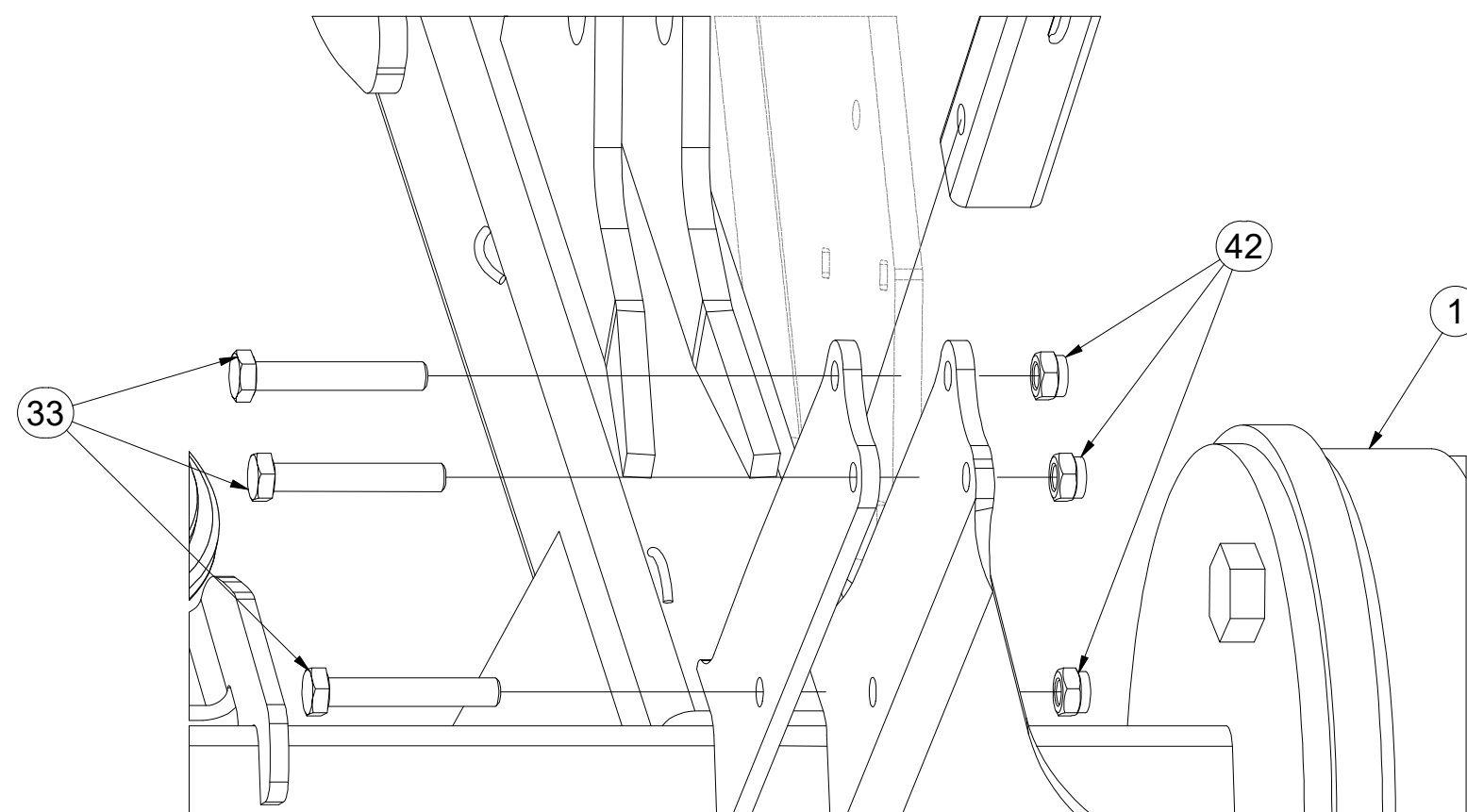

A70NA8FFN003

| Pos. | Part Number | Pcs. |
|------|-------------|------|
| 1 | 3012421 | 1 |
| 13 | 3012431 | 1 |
| 14 | 3012432 | 1 |
| 33 | m12493 | 6 |
| 42 | m04301 | 8 |

CZ SADA NÁPRAVY
 D SATZ AUFHÄNGUNG
 F KIT DE L'ESSIEU

GB AXLE SET
 RU КОМПЛЕКТ ОСИ КОЛЁС
 PL ZESTAW OSI



3012415

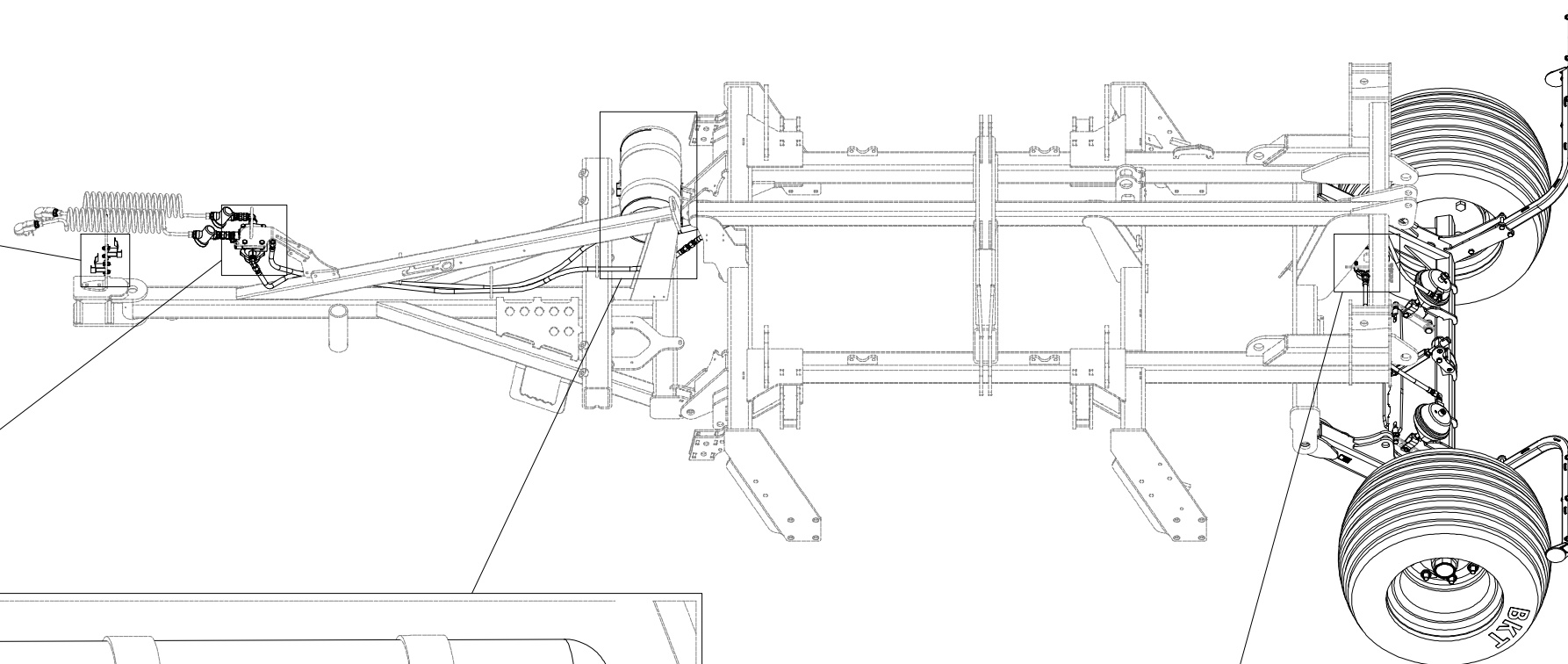
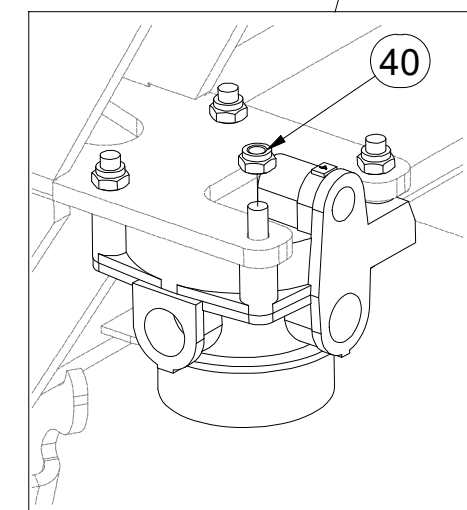
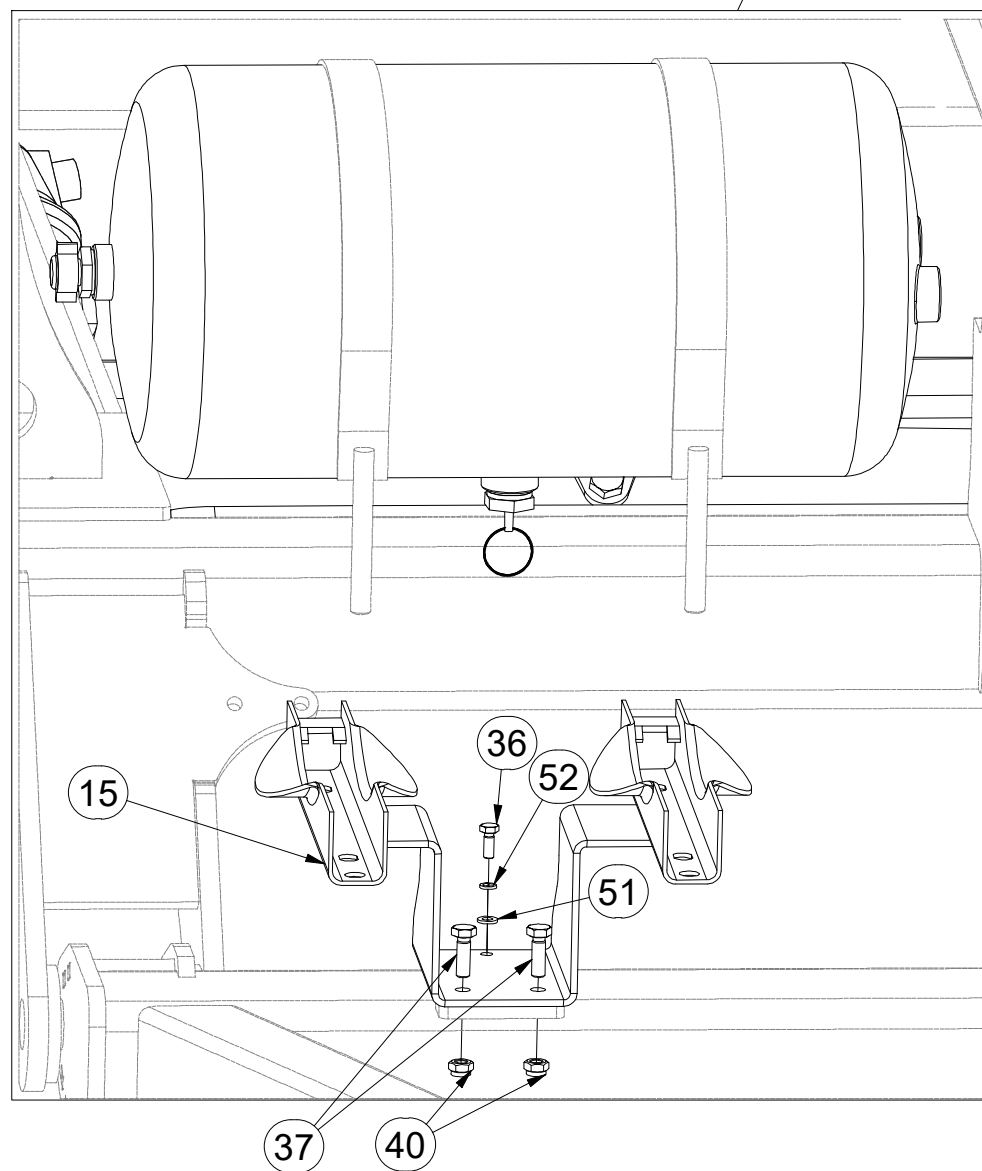
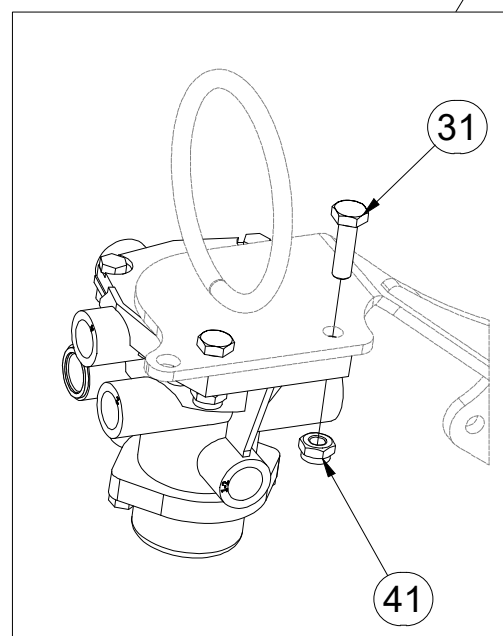
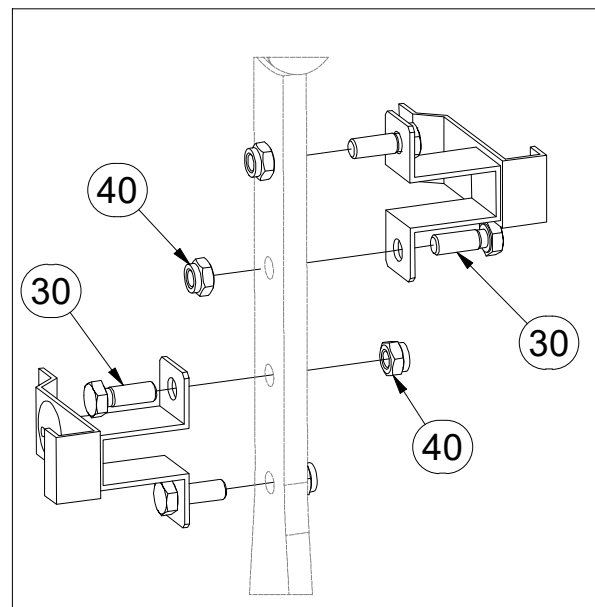

| Pos. | Part Number | Pcs. | Pos. | Part Number | Pcs. |
|------|-------------|------|------|-------------|------|
| 15 | 3012474 | 1 | 40 | m04503 | 10 |
| 30 | m01090 | 4 | 41 | m03775 | 2 |
| 31 | m04613 | 2 | 51 | m01199 | 1 |
| 36 | m01073 | 1 | 52 | m01200 | 1 |
| 37 | m01092 | 2 | | | |

Ⓒ SADA NÁPRAVY

Ⓓ SATZ AUFHÄNGUNG

Ⓕ KIT DE L'ESSIEU

Ⓖ AXLE SET

Ⓡ КОМПЛЕКТ ОСИ КОЛЁС

Ⓢ ZESTAW OSI



3012415

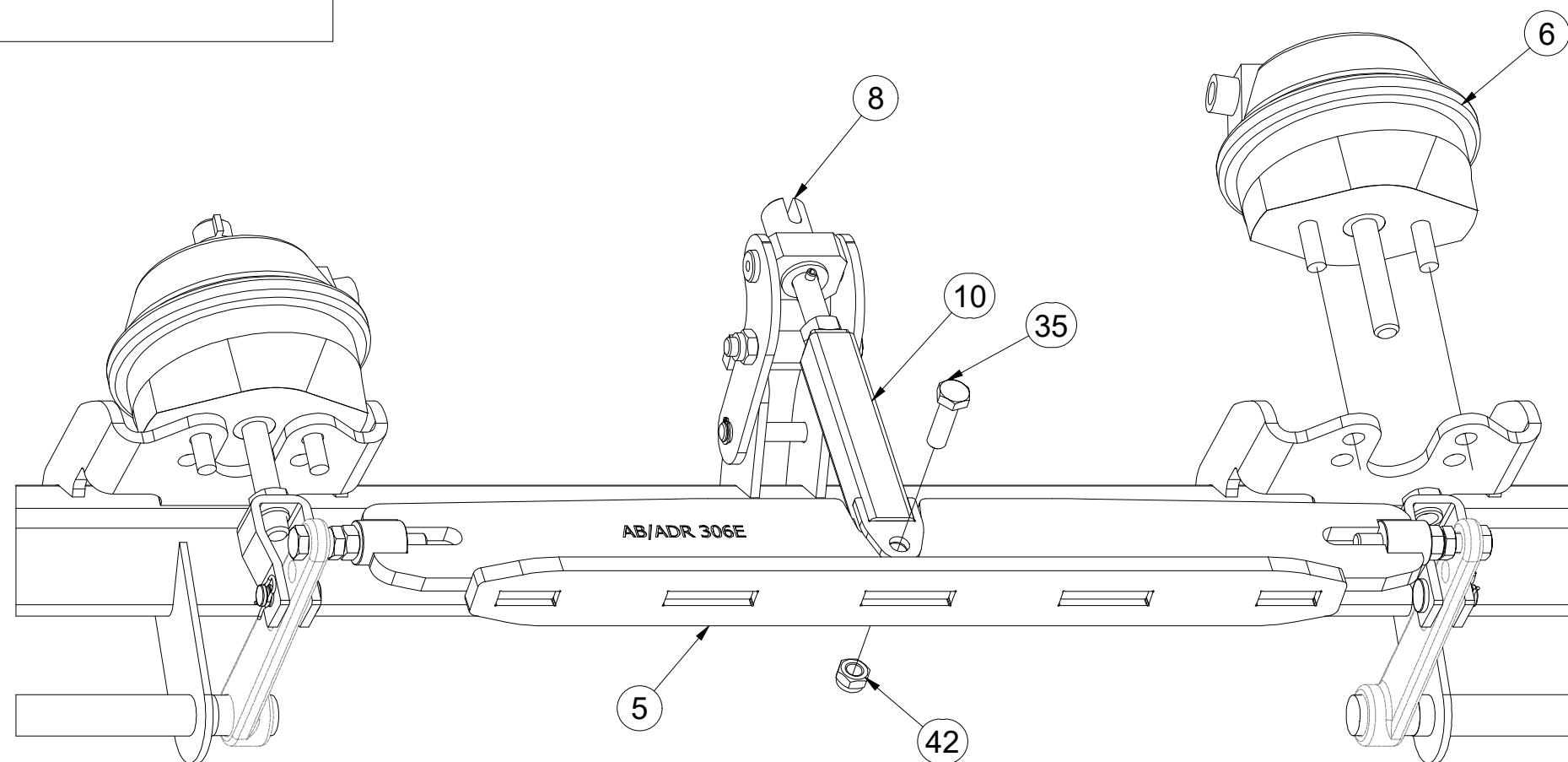
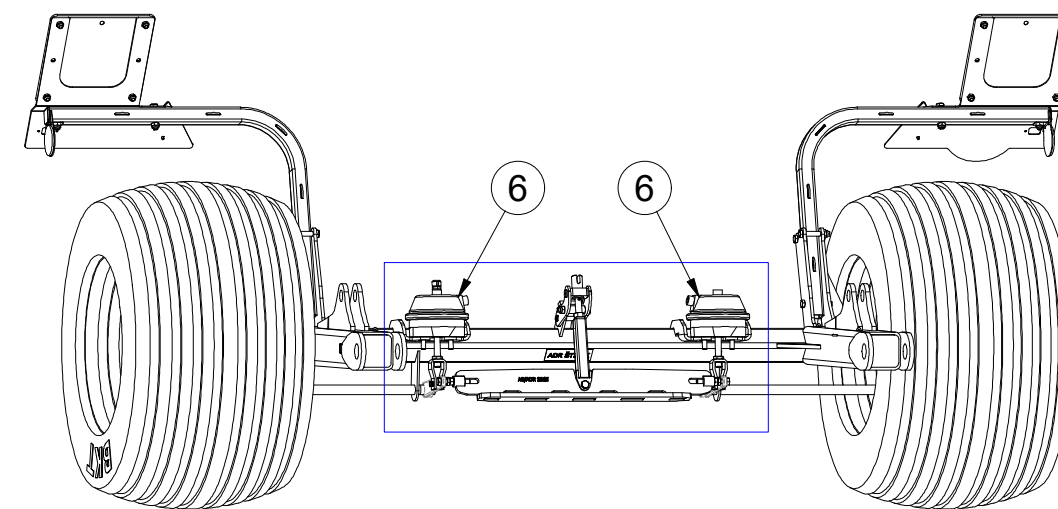
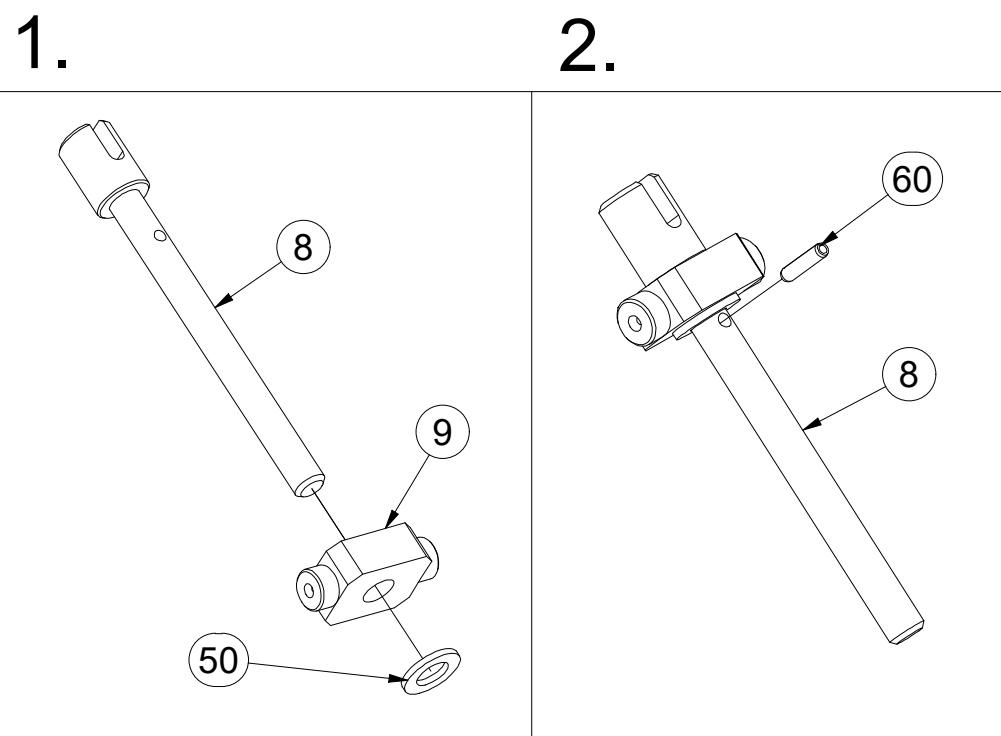

| Pos. | Part Number | Pcs. |
|------|-------------|------|
| 5 | 4026182 | 1 |
| 6 | 4025207 | 2 |
| 8 | 4008114 | 1 |
| 9 | 4004806 | 1 |
| 10 | 3002657 | 1 |
| 35 | m03926 | 1 |
| 42 | m04301 | 8 |
| 50 | m01219 | 1 |
| 60 | m11505 | 1 |

Ⓒ CZ SADA NÁPRAVY

Ⓓ D SATZ AUFHÄNGUNG

Ⓕ F KIT DE L'ESSIEU

Ⓖ GB AXLE SET

Ⓡ RU КОМПЛЕКТ ОСИ КОЛЁС

Ⓟ PL ZESTAW OSI



3012415

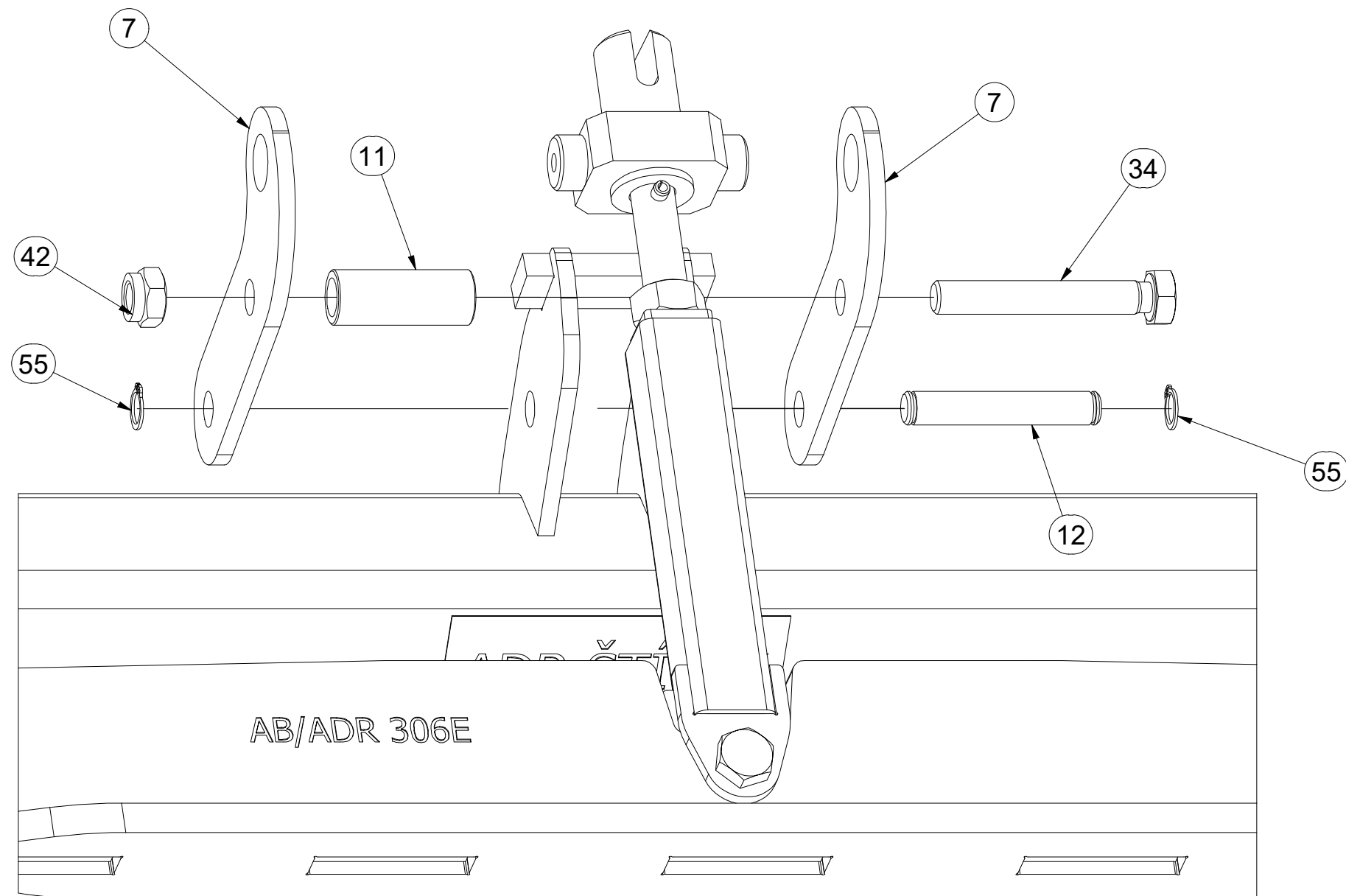
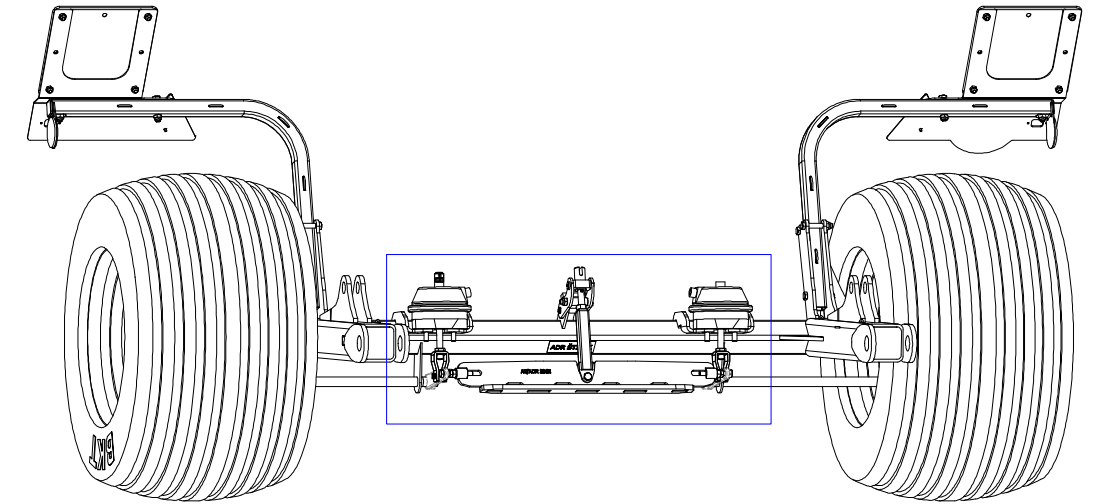

| Pos. | Part Number | Pcs. |
|------|-------------|------|
| 7 | 4004804 | 2 |
| 11 | 4004808 | 1 |
| 12 | 4021912 | 1 |
| 34 | m06446 | 1 |
| 42 | m04301 | 8 |
| 55 | m18357 | 2 |

- Ⓒ SADA NÁPRAVY
- Ⓓ SATZ AUFHÄNGUNG
- Ⓕ KIT DE L'ESSIEU

- Ⓖ AXLE SET
- Ⓡ КОМПЛЕКТ ОСИ КОЛЁС
- Ⓟ ZESTAW OSI



3012415

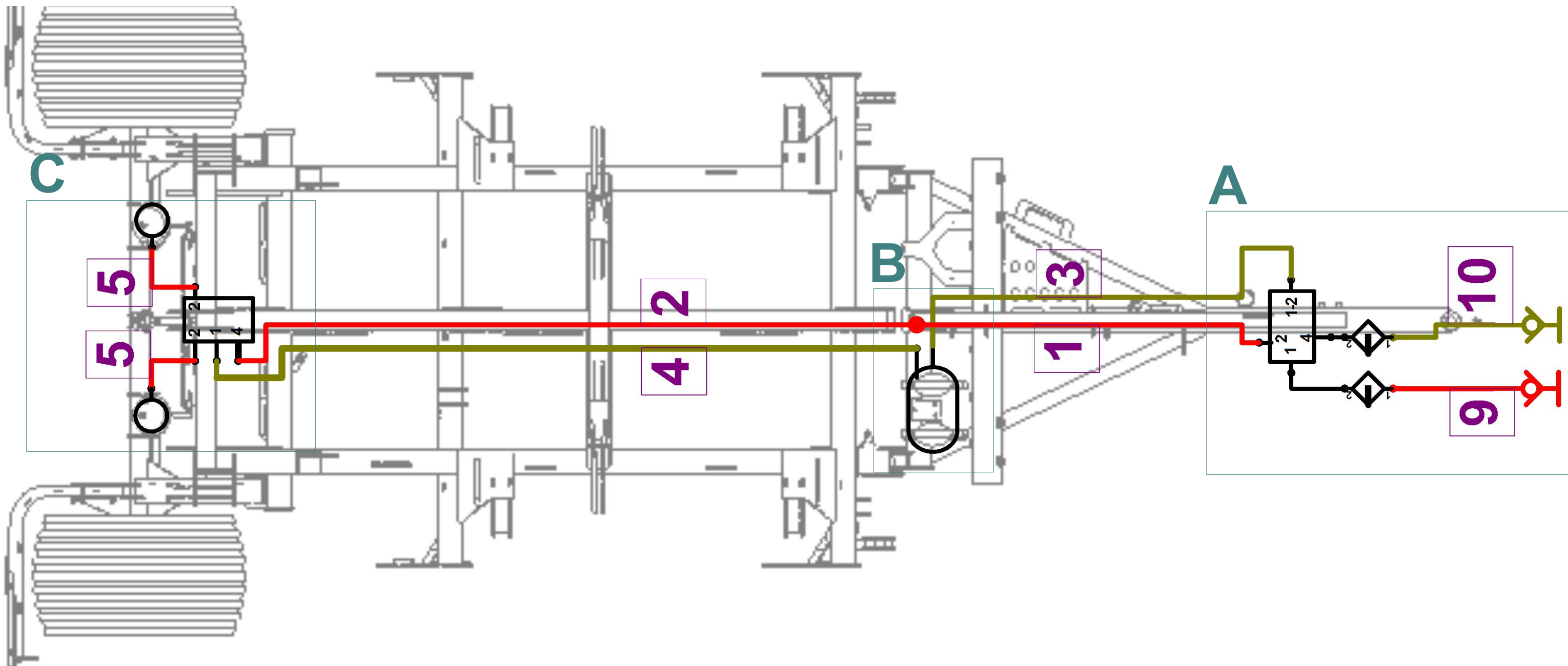

m19041

| Pos. | Part Number | Pcs. |
|------|-------------|------|
| 1 | m18886 | 1 |
| 2 | m18795 | 1 |
| 3 | m18911 | 1 |
| 4 | m18914 | 1 |
| 5 | m18879 | 2 |

m18910

| Pos. | Part Number | Pcs. |
|------|-------------|------|
| 9 | m09949 | 1 |
| 10 | m09948 | 1 |

Ⓒ SADA NÁPRAVY

Ⓓ SATZ AUFHÄNGUNG

Ⓕ KIT DE L'ESSIEU

Ⓖ AXLE SET

Ⓡ КОМПЛЕКТ ОСИ КОЛЁС

Ⓢ ZESTAW OSI



m18910

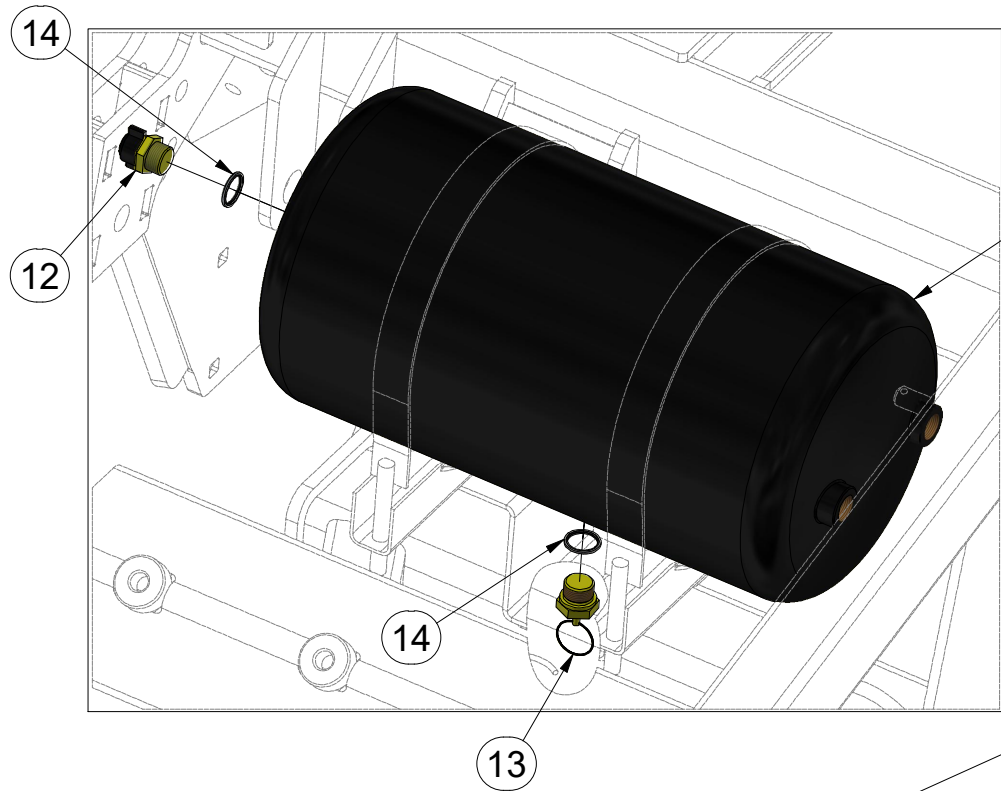

B

23

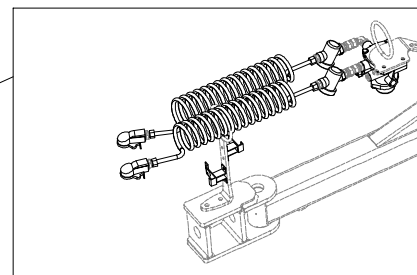

C

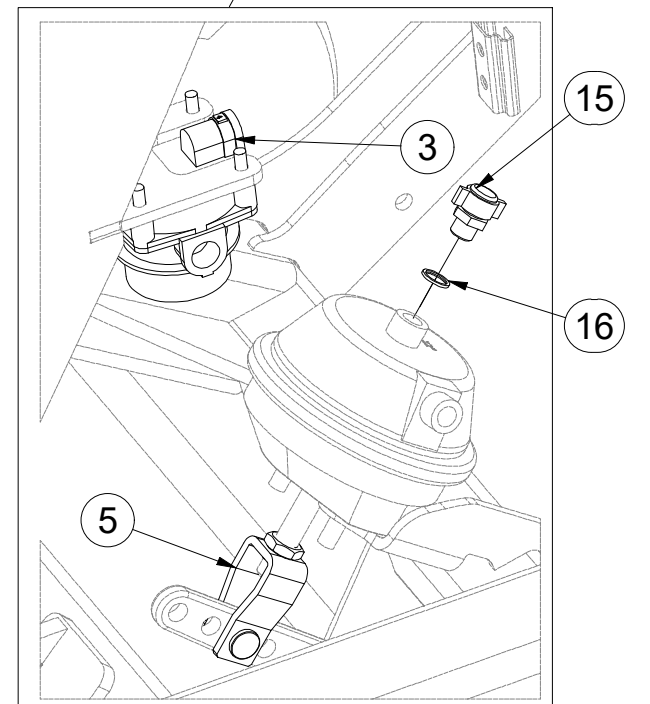

A

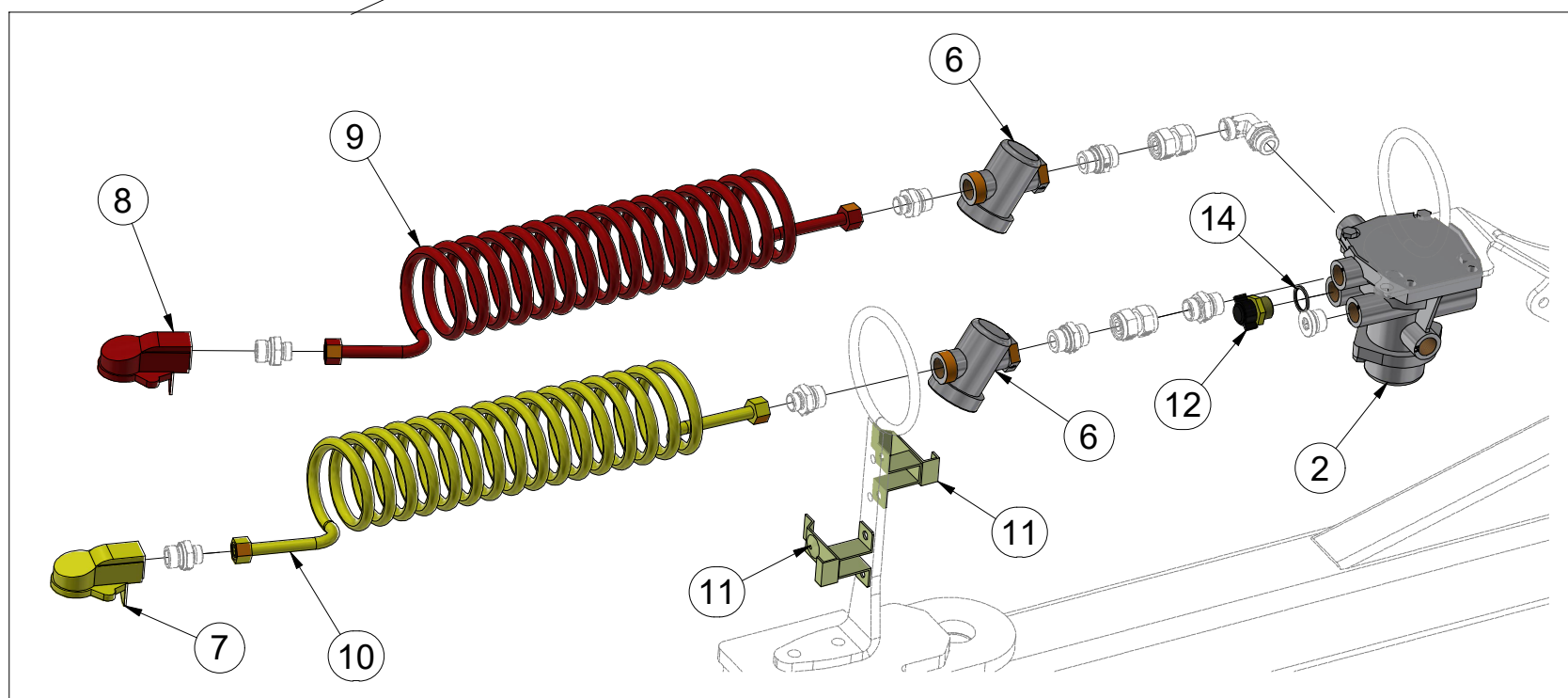

| Pos. | Part Number | Pcs. | Pos. | Part Number | Pcs. |
|------|-------------|------|------|-------------|------|
| 2 | m10608 | 1 | 11 | m09789 | 2 |
| 3 | m09790 | 1 | 12 | m09816 | 2 |
| 5 | m09793 | 2 | 13 | m09797 | 1 |
| 6 | m11733 | 2 | 14 | m09818 | 3 |
| 7 | m11734 | 1 | 15 | m09815 | 1 |
| 8 | m11735 | 1 | 16 | m09817 | 1 |
| 9 | m09949 | 1 | 23 | m18903 | 1 |
| 10 | m09948 | 1 | | | |

Ⓒ SADA NÁPRAVY

Ⓓ SATZ AUFHÄNGUNG

Ⓕ KIT DE L'ESSIEU

Ⓒ AXLE SET

Ⓓ КОМПЛЕКТ ОСИ КОЛЁС

Ⓕ ZESTAW OSI



m19041

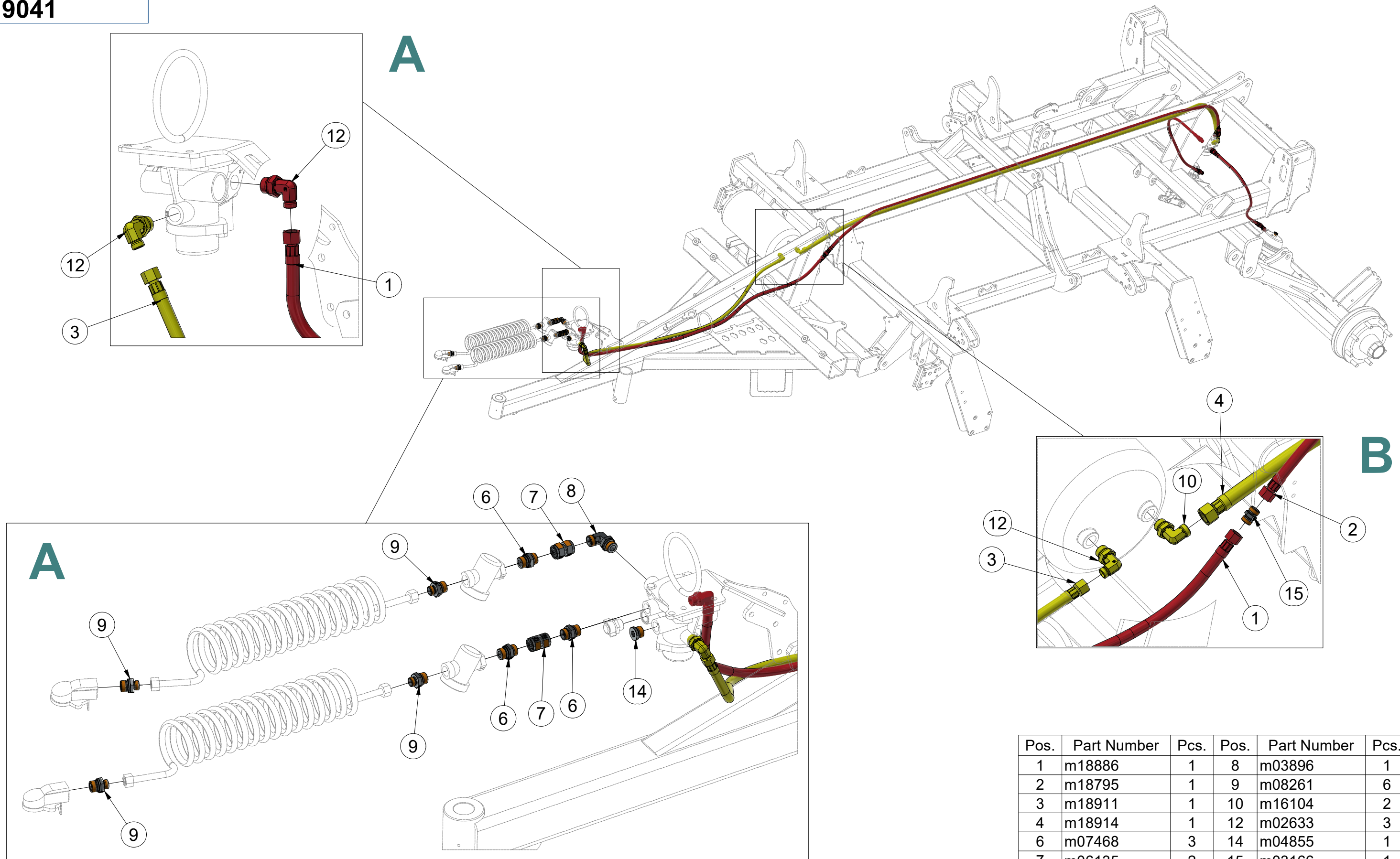

| Pos. | Part Number | Pcs. | Pos. | Part Number | Pcs. |
|------|-------------|------|------|-------------|------|
| 1 | m18886 | 1 | 8 | m03896 | 1 |
| 2 | m18795 | 1 | 9 | m08261 | 6 |
| 3 | m18911 | 1 | 10 | m16104 | 2 |
| 4 | m18914 | 1 | 12 | m02633 | 3 |
| 6 | m07468 | 3 | 14 | m04855 | 1 |
| 7 | m06135 | 2 | 15 | m03166 | 1 |

- Ⓒ SADA NÁPRAVY
- Ⓓ SATZ AUFHÄNGUNG
- Ⓕ KIT DE L'ESSIEU

- Ⓒ AXLE SET
- Ⓓ КОМПЛЕКТ ОСИ КОЛЁС
- Ⓕ ZESTAW OSI



m19041

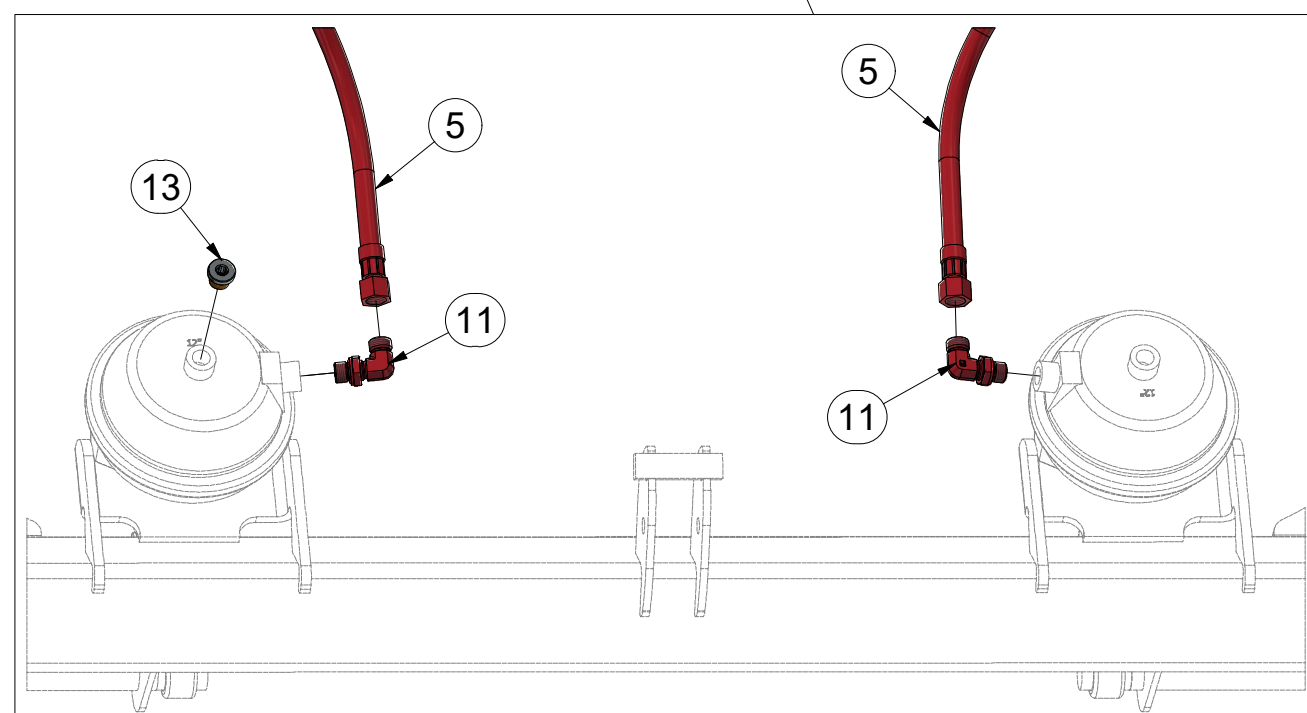
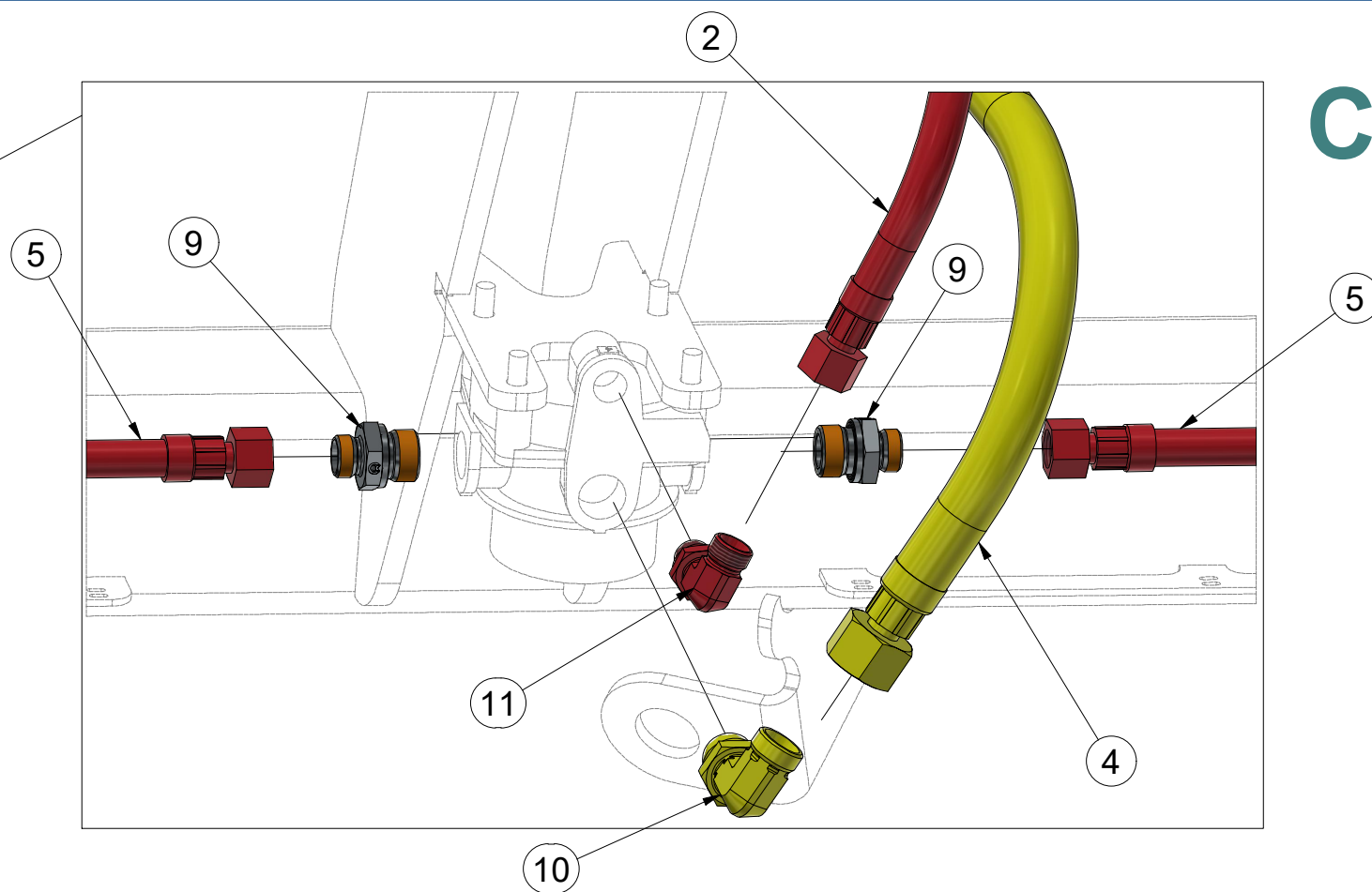
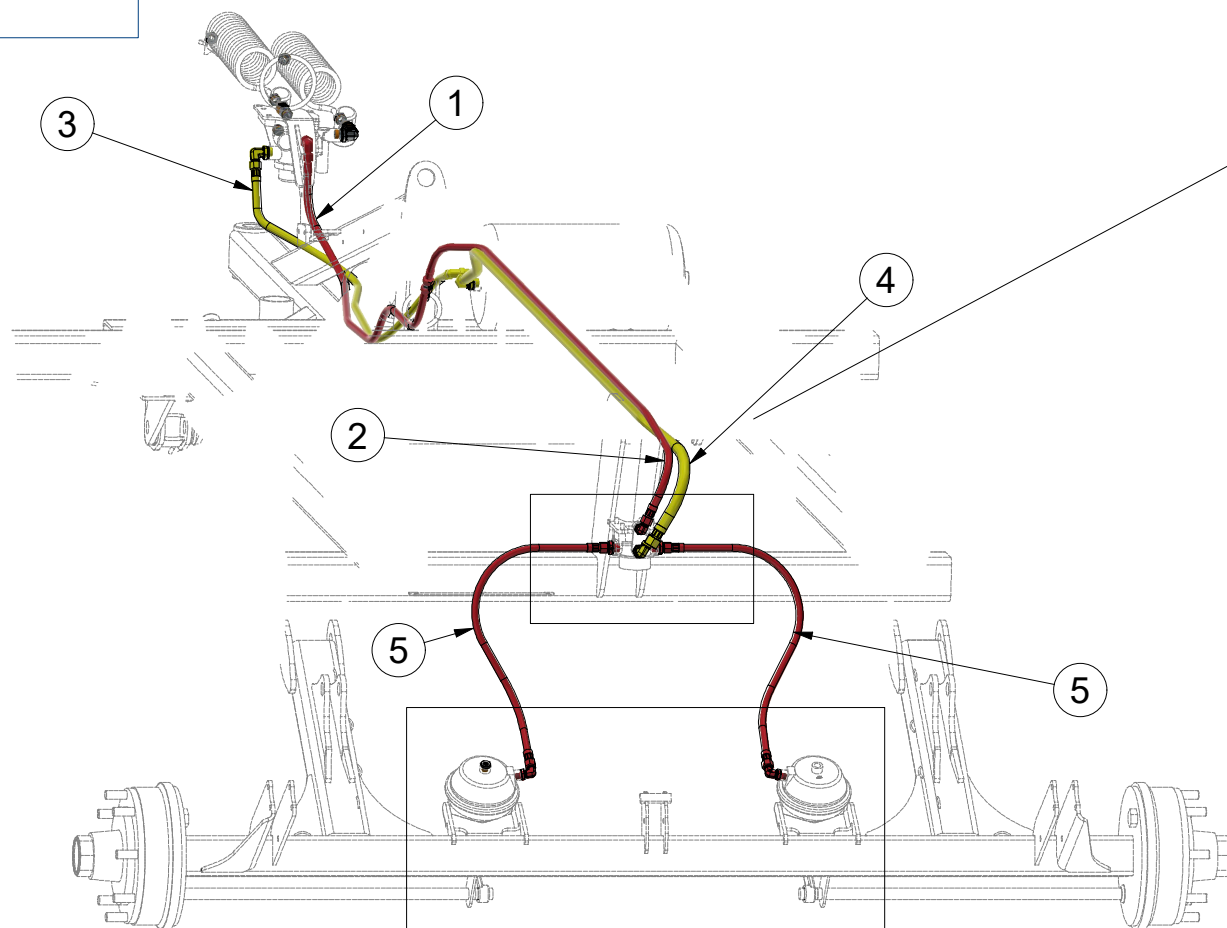

C

| Pos. | Part Number | Pcs. |
|------|-------------|------|
| 1 | m18886 | 1 |
| 2 | m18795 | 1 |
| 3 | m18911 | 1 |
| 4 | m18914 | 1 |
| 5 | m18879 | 2 |
| 9 | m08261 | 6 |
| 10 | m16104 | 2 |
| 11 | m17575 | 3 |
| 13 | m04518 | 1 |

Ⓒ CZ SADA NÁPRAVY

Ⓓ D SATZ AUFHÄNGUNG

Ⓕ F KIT DE L'ESSIEU

Ⓖ GB AXLE SET

Ⓡ RU КОМПЛЕКТ ОСИ КОЛЁС

Ⓟ PL ZESTAW OSI



4026182

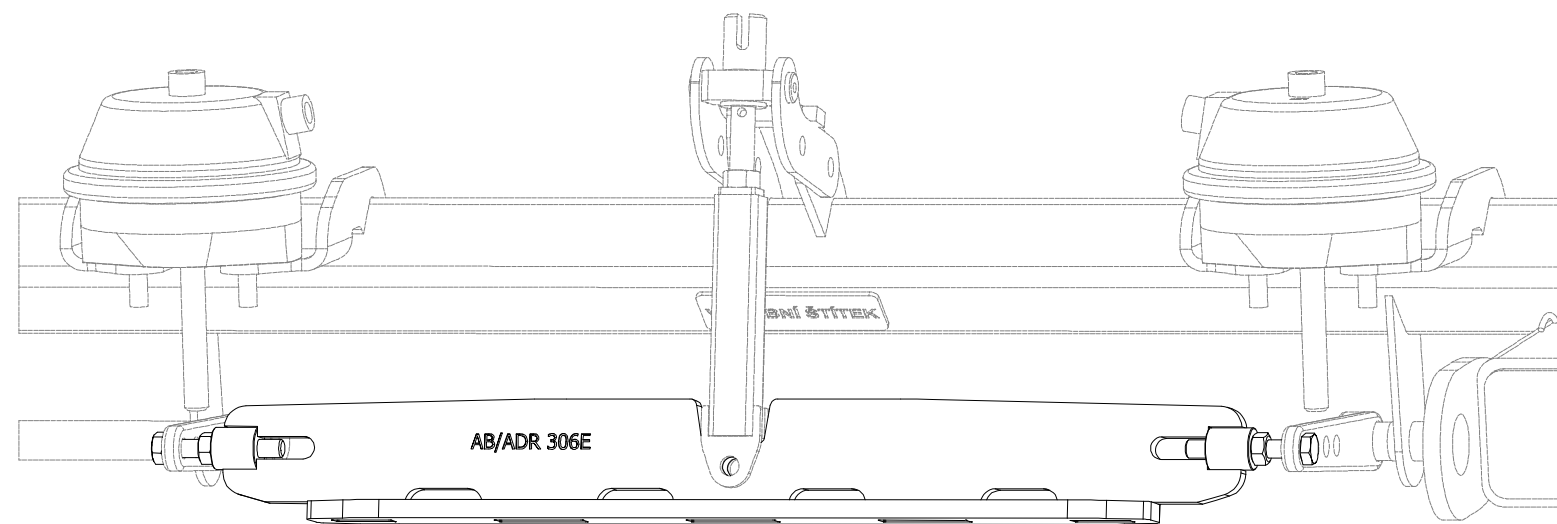

| Pos. | Part Number | Pcs. |
|------|-------------|------|
| 1 | 3012890 | 1 |
| 5 | m06446 | 2 |
| 10 | m01305 | 2 |

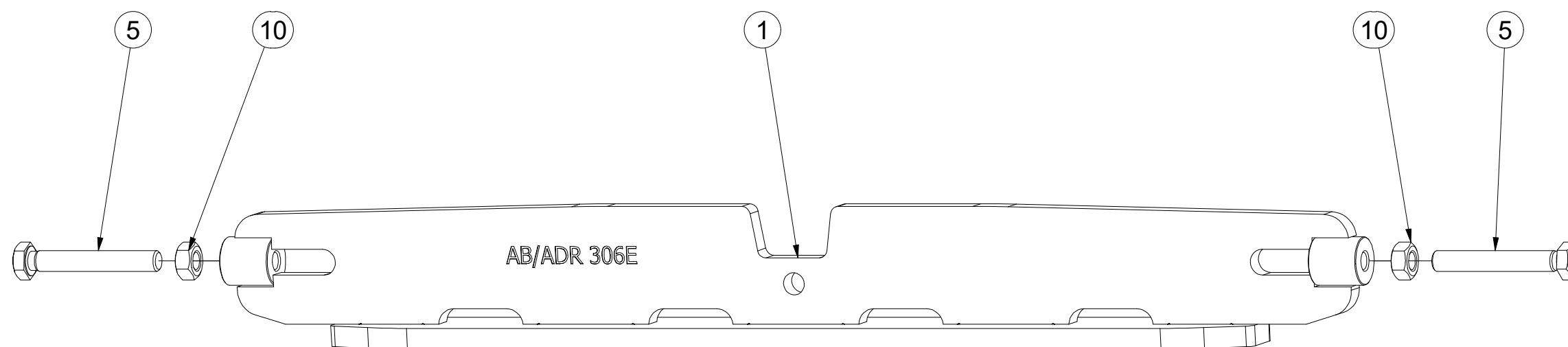

ⒸZ NÁPRAVA

ⒸD ACHSE

ⒸF ESSIEU

ⒸGB AXLE

ⒸRU OCB

ⒸPL OS



A70NA8FFN003

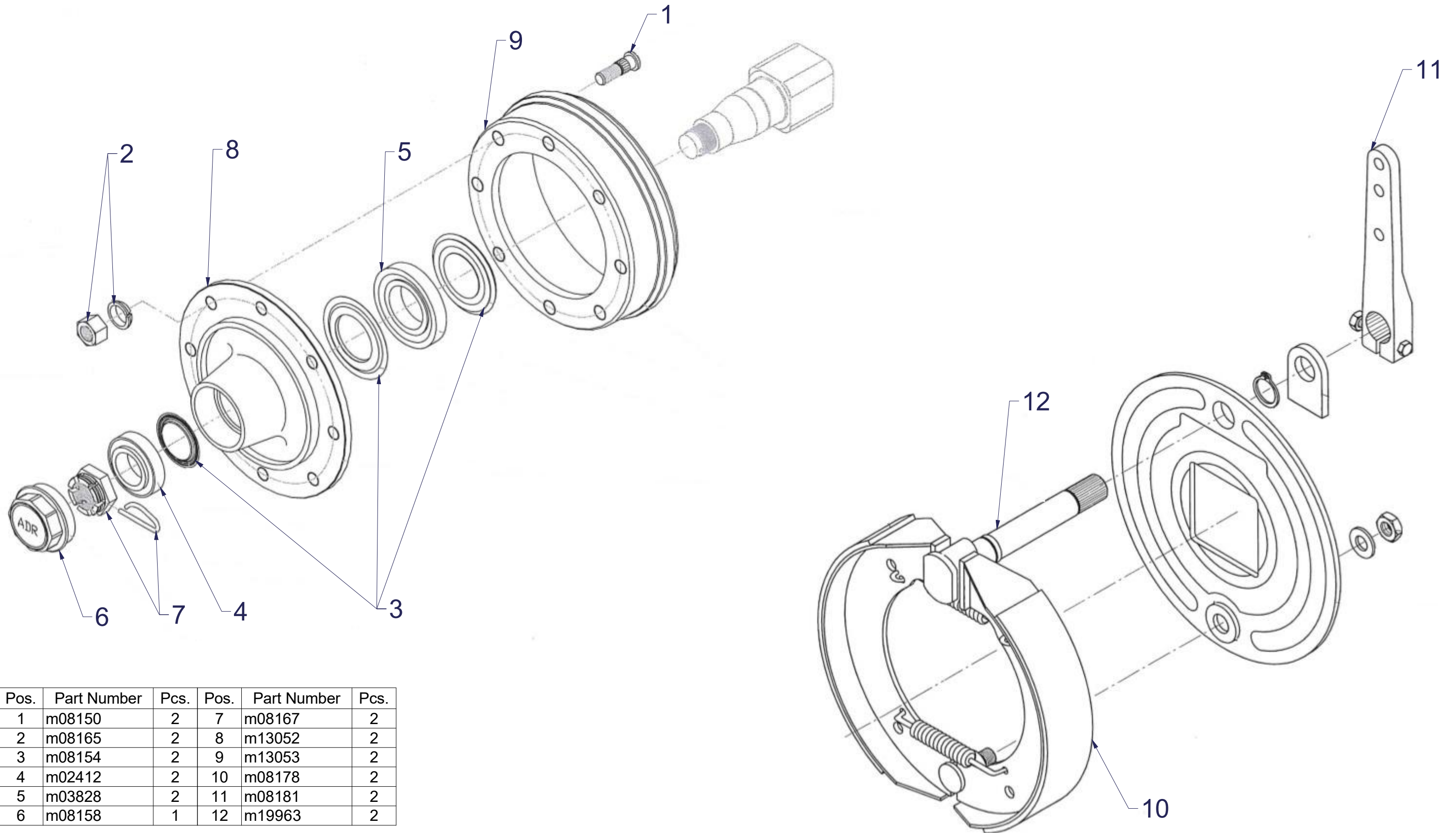

| Pos. | Part Number | Pcs. | Pos. | Part Number | Pcs. |
|------|-------------|------|------|-------------|------|
| 1 | m08150 | 2 | 7 | m08167 | 2 |
| 2 | m08165 | 2 | 8 | m13052 | 2 |
| 3 | m08154 | 2 | 9 | m13053 | 2 |
| 4 | m02412 | 2 | 10 | m08178 | 2 |
| 5 | m03828 | 2 | 11 | m08181 | 2 |
| 6 | m08158 | 1 | 12 | m19963 | 2 |

(CZ) SADA HOMOLOGACE
 (D) HOMOLOGATIONSATZ
 (F) KIT DE HOMOLOGATION

(GB) SET OF HOMOLOGATION
 (RU) КОМПЛЕКТ УТВЕРЖДЕНИЯ
 (PL) ZESTAW HOMOLOGACJA



VZ00018454

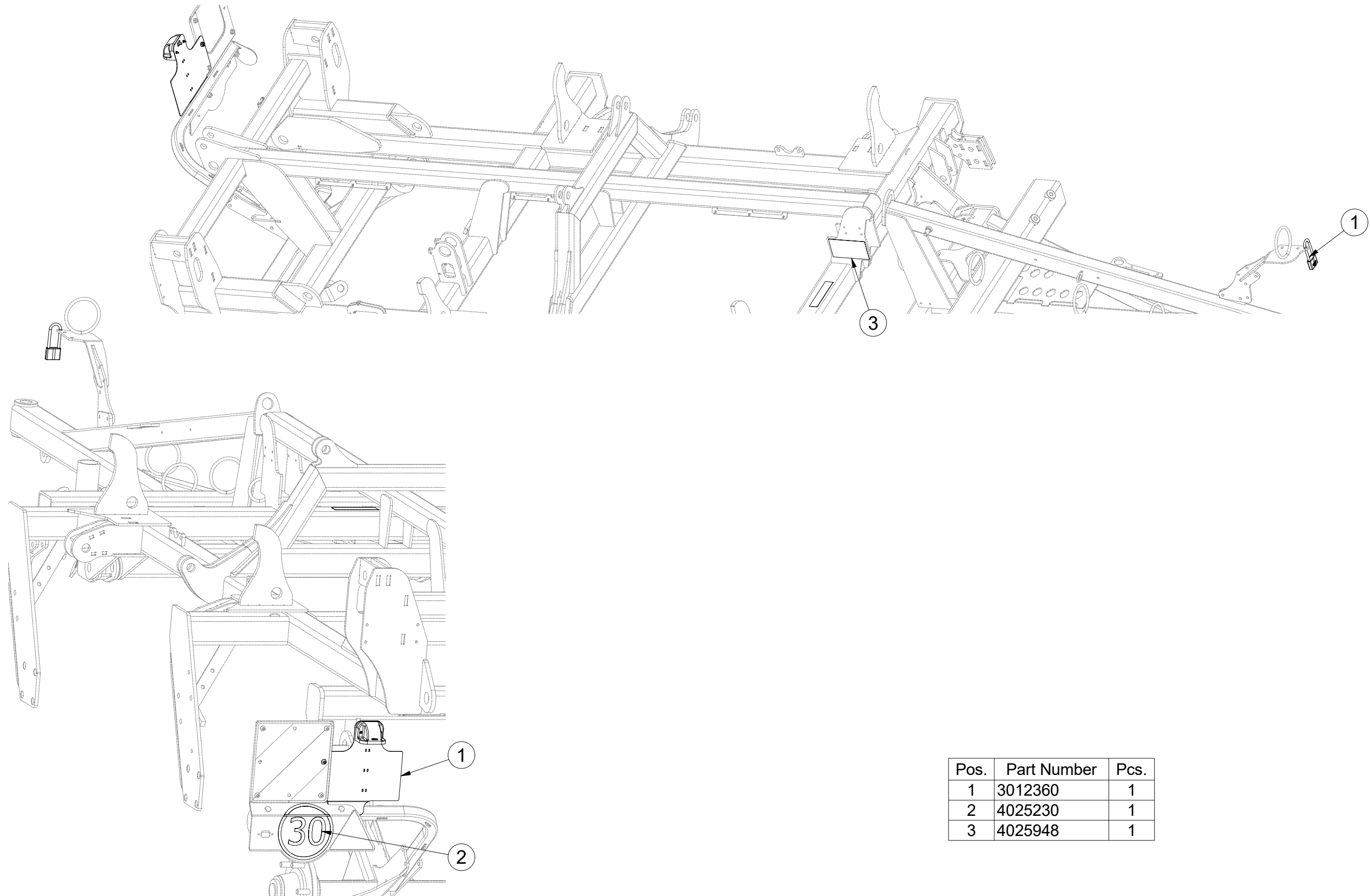

| Pos. | Part Number | Pcs. |
|------|-------------|------|
| 1 | 3012360 | 1 |
| 2 | 4025230 | 1 |
| 3 | 4025948 | 1 |

ⒸZ TERČ ZADNÍ LEVÝ - HOMOLOGACE

Ⓓ SCHILD, HINTERES, LINKES - HOMOLOGATION

Ⓕ CIBLE ARRIÈRE GAUCHE - HOMOLOGATION

ⒸB LEFT REAR DISC - HOMOLOGATION

ⒸU ЩИТОК ЗАДНИЙ ЛЕВЫЙ - УТВЕРЖДЕНИЯ

ⒸL TARCZA TYLNA LEWA - HOMOLOGACJA



3012360

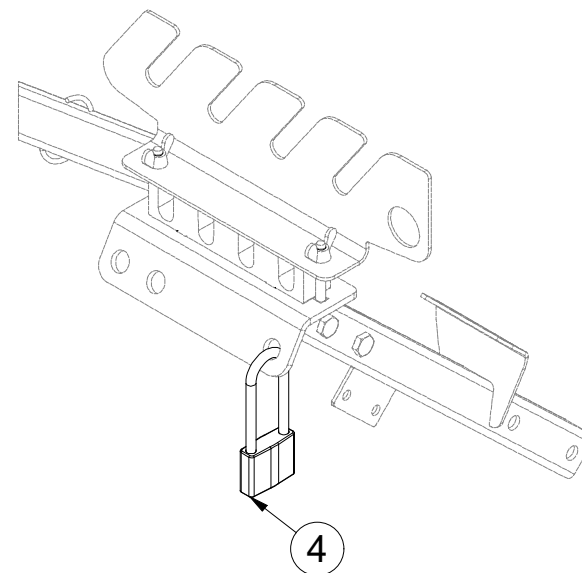
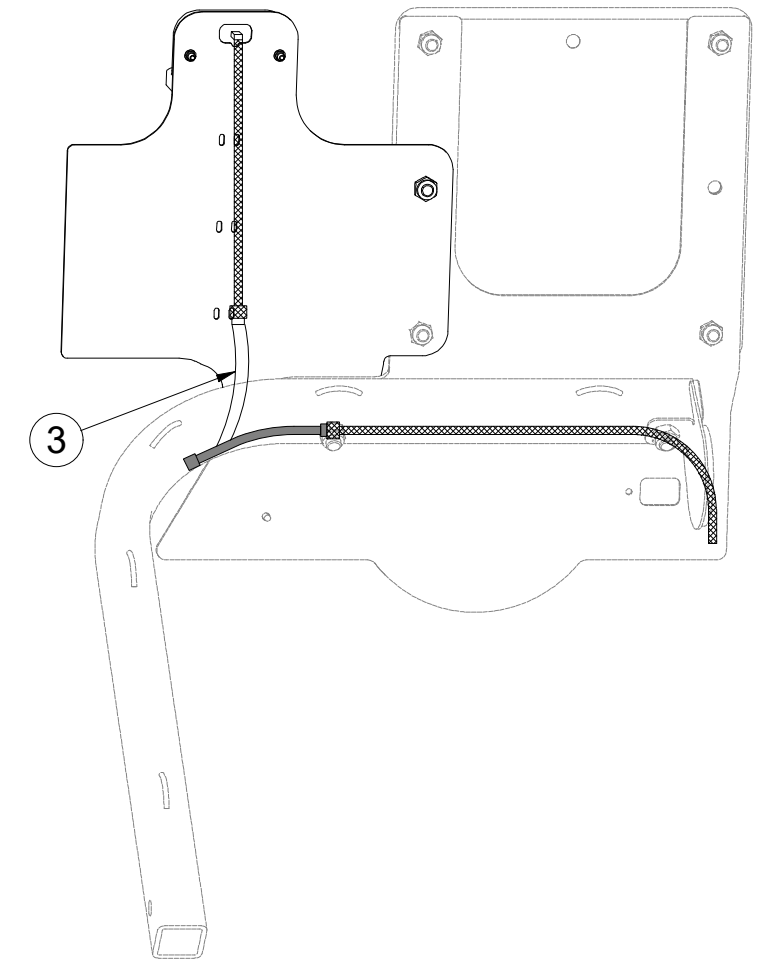
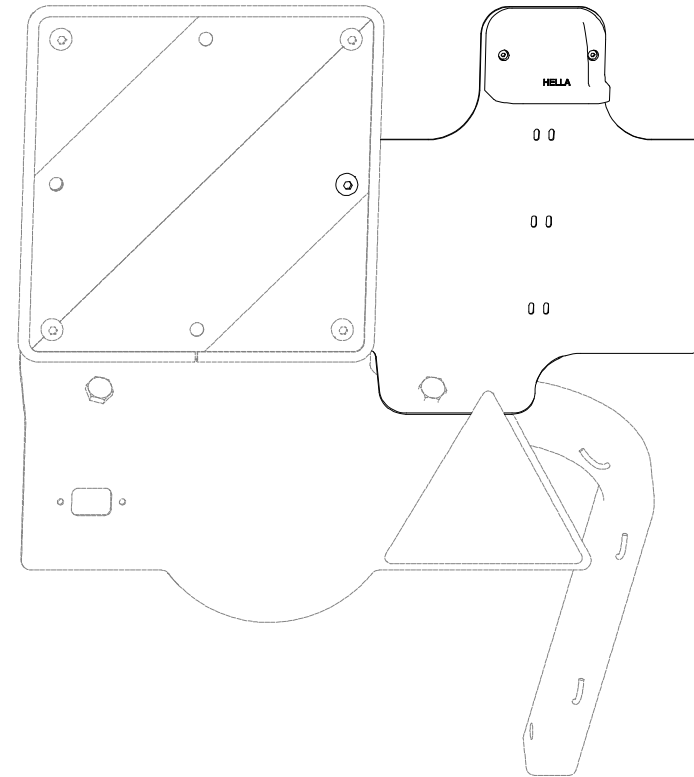
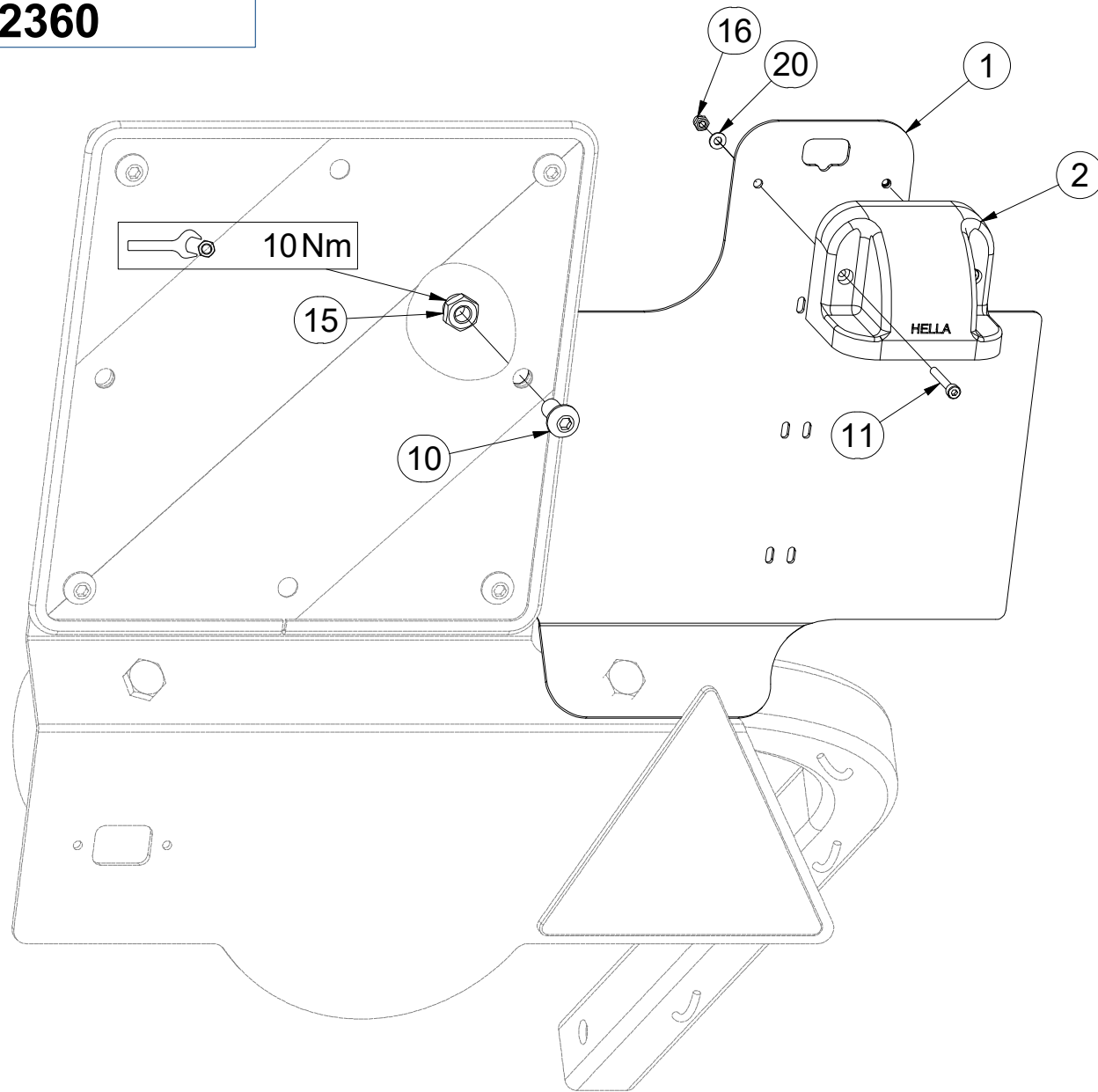

| Pos. | Part Number | Pcs. |
|------|-------------|------|
| 1 | 3012366 | 1 |
| 2 | m18862 | 1 |
| 3 | m18861 | 1 |
| 4 | m18814 | 1 |
| 10 | m16637 | 1 |
| 11 | m16861 | 2 |
| 15 | m03775 | 1 |
| 16 | m05562 | 2 |
| 20 | m05597 | 2 |

ⒸZ TERČ ZADNÍ LEVÝ

Ⓓ SCHILD, HINTERES, LINKES

Ⓕ CIBLE ARRIÈRE GAUCHE

3012431

ⒼB LEFT REAR DISC

ⒺЩИТОК ЗАДНИЙ ЛЕВЫЙ

ⒽL TARCZA TYLNA LEWA

Farmet

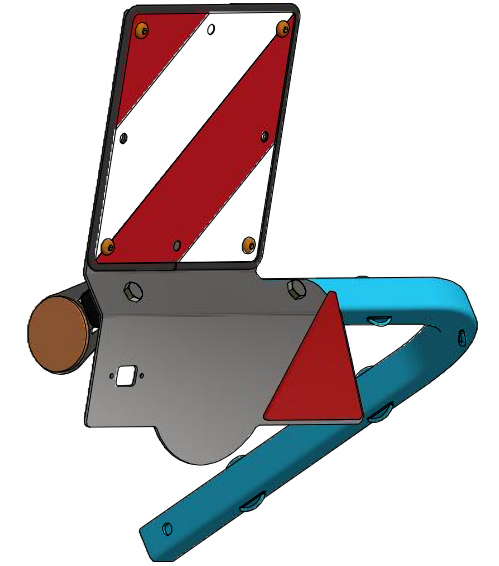
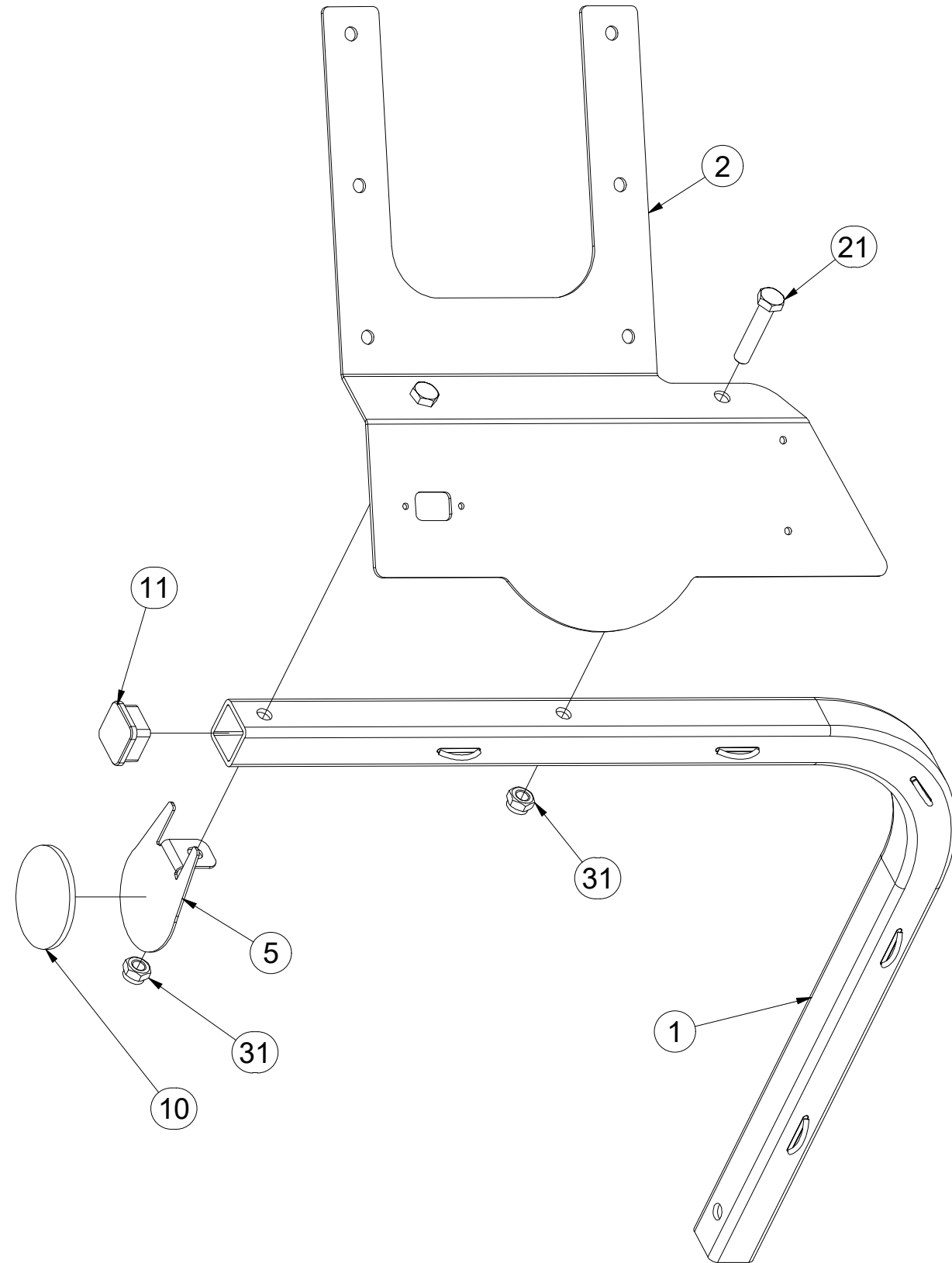

| Pos. | Part Number | Pcs. |
|------|-------------|------|
| 1 | 3012433 | 1 |
| 2 | 3012365 | 1 |
| 5 | 4024926 | 1 |
| 10 | m02579 | 1 |
| 11 | m12689 | 1 |
| 21 | m01131 | 2 |
| 31 | m04301 | 2 |

ⒸZ TERČ ZADNÍ LEVÝ

Ⓓ SCHILD, HINTERES, LINKES

Ⓕ CIBLE ARRIÈRE GAUCHE

ⒼB LEFT REAR DISC

ⒺU ЩИТОК ЗАДНИЙ ЛЕВЫЙ

ⒼL TARCZA TYLNA LEWA



3012431

| Pos. | Part Number | Pcs. |
|------|-------------|------|
| 3 | m18855 | 1 |
| 4 | 9005707 | 1 |
| 12 | m02497 | 1 |
| 20 | m16637 | 4 |
| 30 | m03775 | 4 |
| 35 | m01209 | 4 |

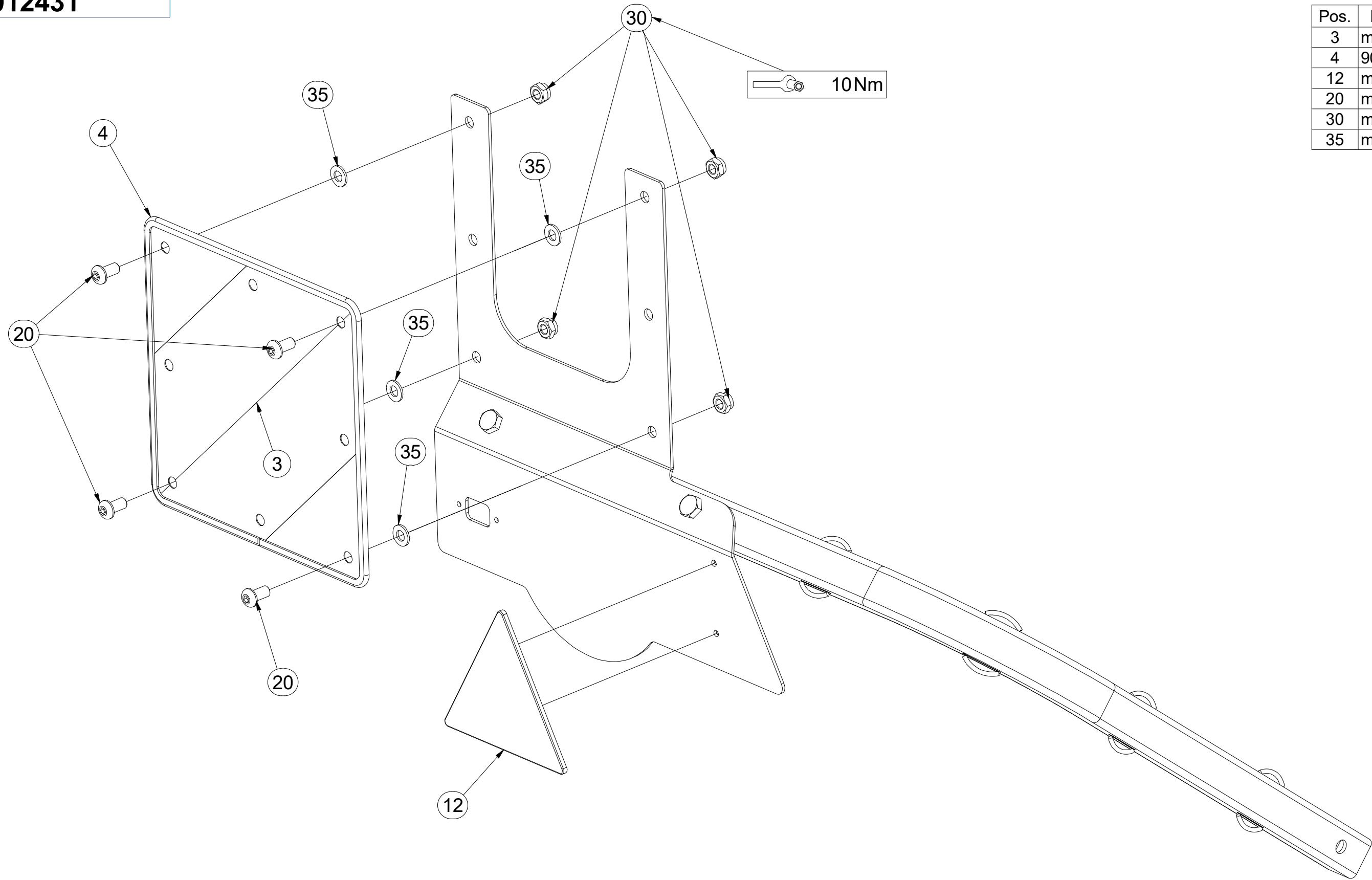

Ⓒ TERČ ZADNÍ PRAVÝ

Ⓓ SCHILD, HINTERES, RECHTES

Ⓕ CIBLE ARRIÈRE DROITE

3012432

Ⓖ RIGHT REAR DISC

Ⓡ ЩИТОК ЗАДНИЙ ПРАВЫЙ

Ⓢ TARCZA TYLNA PRAWA

Farmet

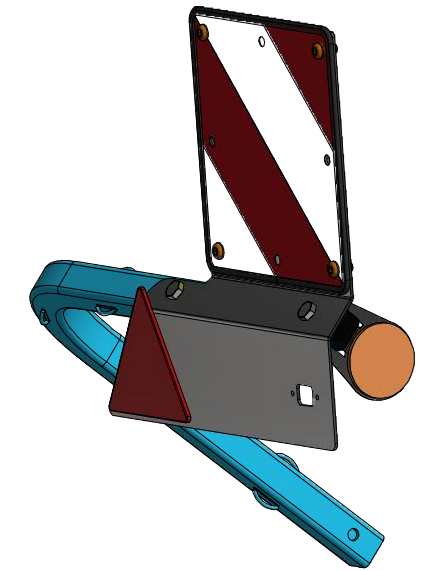
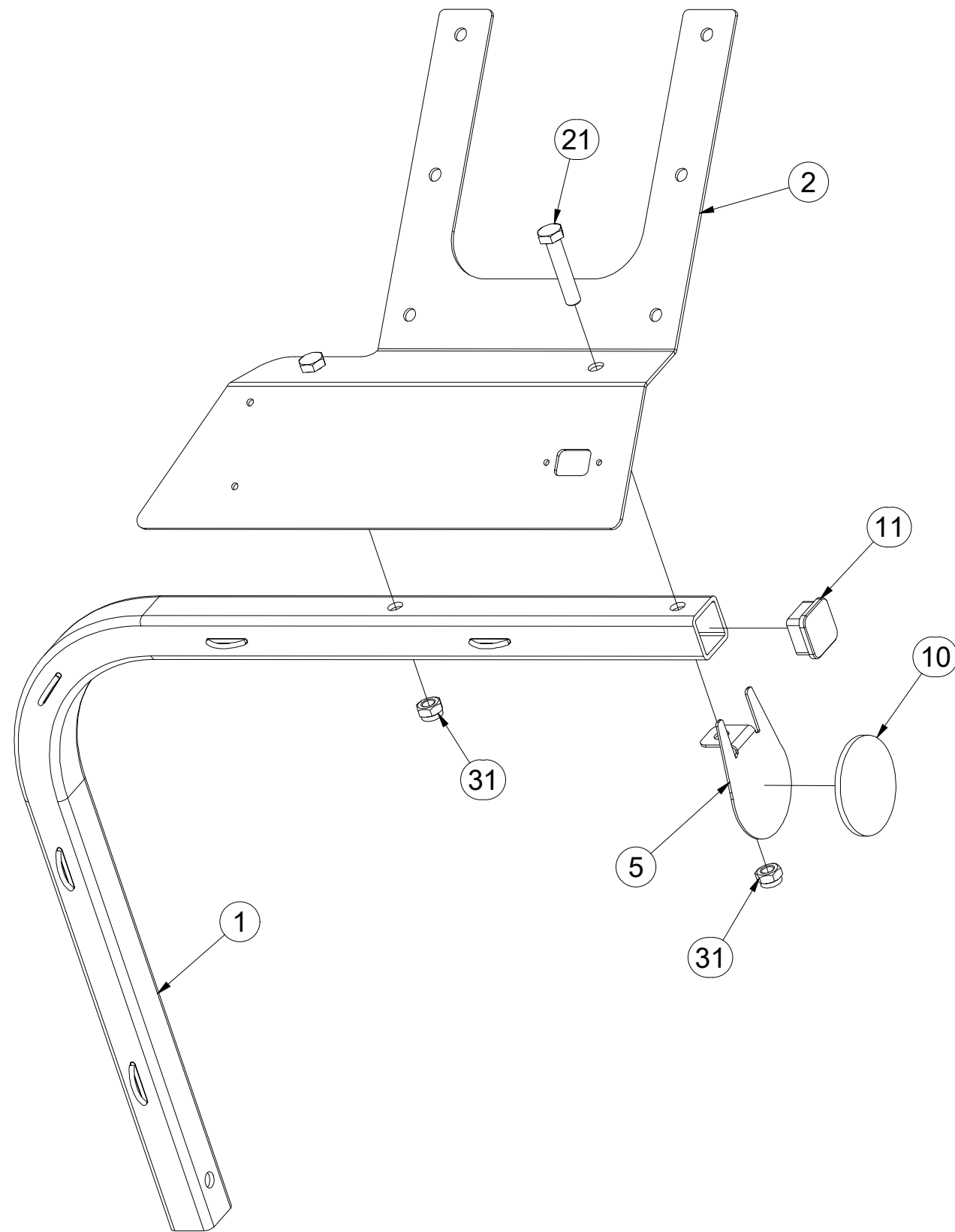

| Pos. | Part Number | Pcs. |
|------|-------------|------|
| 1 | 3012433 | 1 |
| 2 | 3012390 | 1 |
| 5 | 4024926 | 1 |
| 10 | m02579 | 1 |
| 11 | m12689 | 1 |
| 21 | m01131 | 2 |
| 31 | m04301 | 2 |

ⒸZ TERČ ZADNÍ PRAVÝ

Ⓓ SCHILD, HINTERES, RECHTES

Ⓕ CIBLE ARRIÈRE DROITE

ⒼB RIGHT REAR DISC

ⒺU ЩИТОК ЗАДНИЙ ПРАВЫЙ

ⒶL TARCZA TYLNA PRAWA



3012432

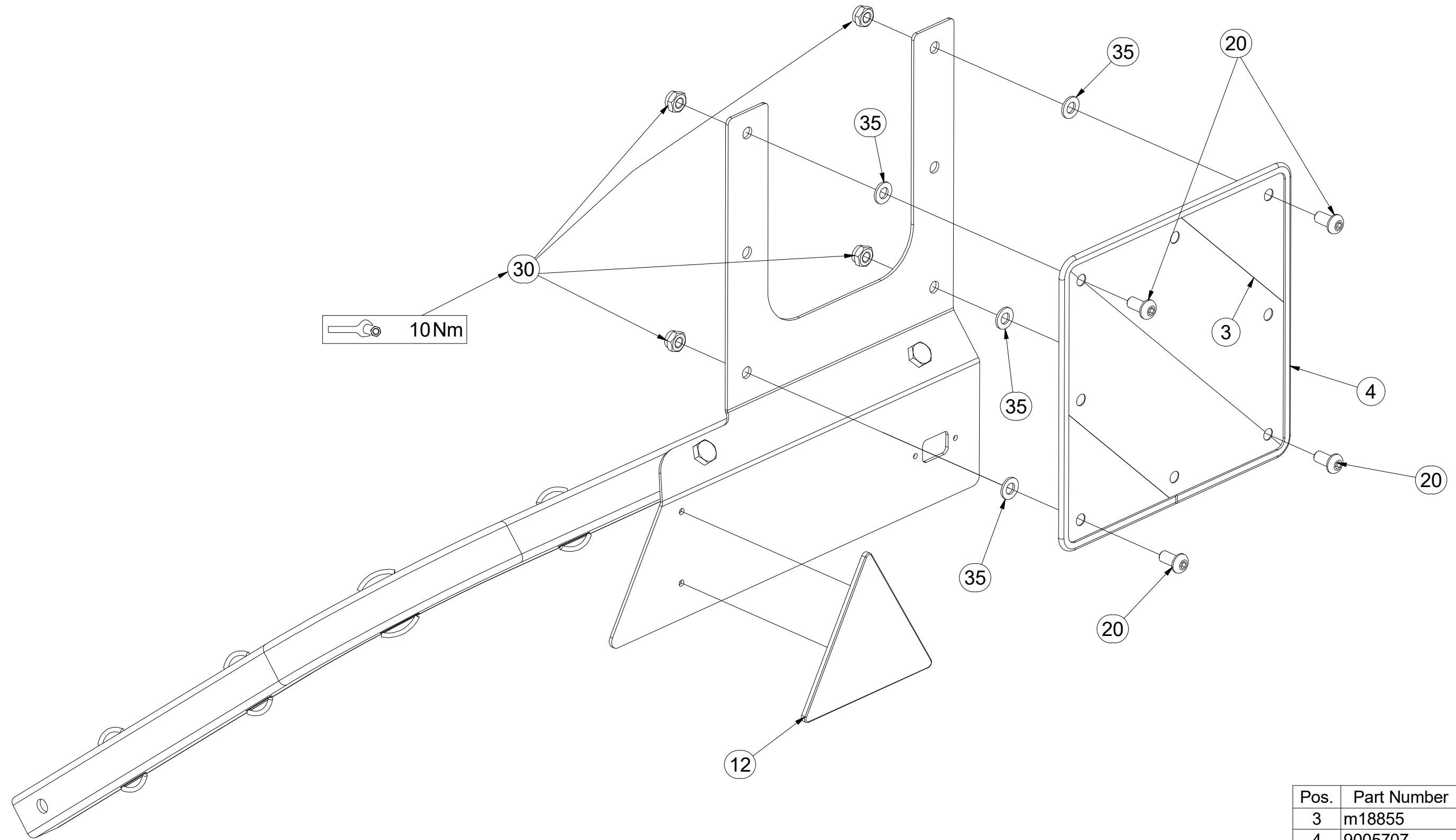

| Pos. | Part Number | Pcs. |
|------|-------------|------|
| 3 | m18855 | 1 |
| 4 | 9005707 | 1 |
| 12 | m02497 | 1 |
| 20 | m16637 | 4 |
| 30 | m03775 | 4 |
| 35 | m01209 | 4 |

Ⓒ SAMOLEPKY STROJE

Ⓓ AUFKLEBER MASCHINEN

Ⓕ VOITURE MACHINES

Ⓖ STICKERS MACHINES

Ⓡ СТИКЕРЫ МАШИНЫ

Ⓟ NAKLEJKI MASZYNY



4025230

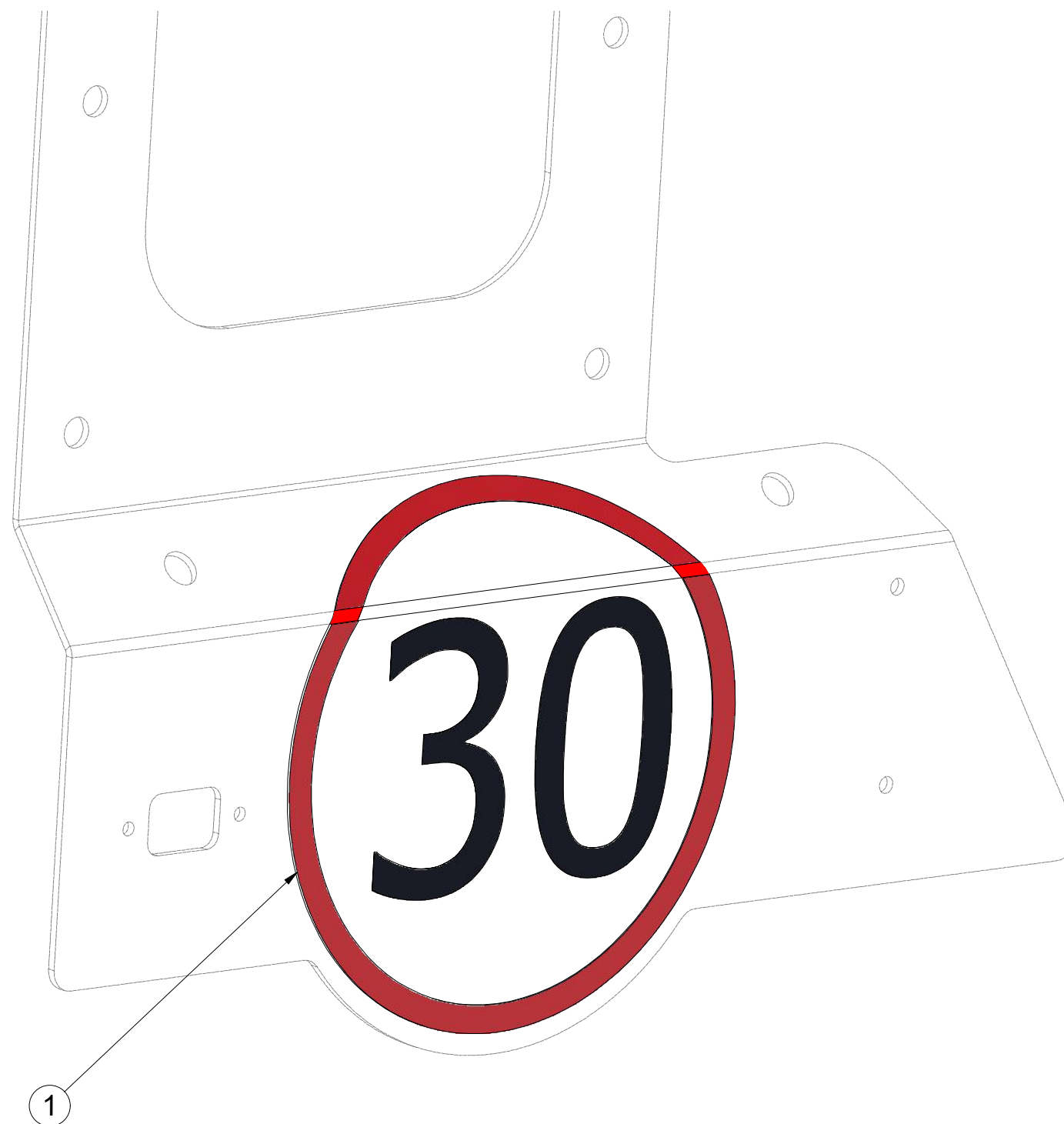

| Pos. | Part Number | Pcs. |
|------|-------------|------|
| 1 | m19161 | 1 |

ⒸZ SOUPRAVA TĚSNIVA PÍSTNIC

Ⓓ KOLBENSTANGENDICHTUNGSMITTELSATZ

Ⓕ SET DE GARNITURE DES TIGES DE PISTON

ⒼB SEALING SET FOR PISTON RODS

ⒺR КОМПЛЕКТ ПРОКЛАДОК ЦИЛИНДРОВ

ⒻL ZESTAW USZCZELEK TRZPIENIA TŁOKA

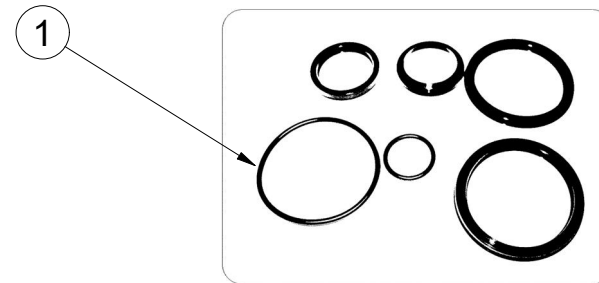
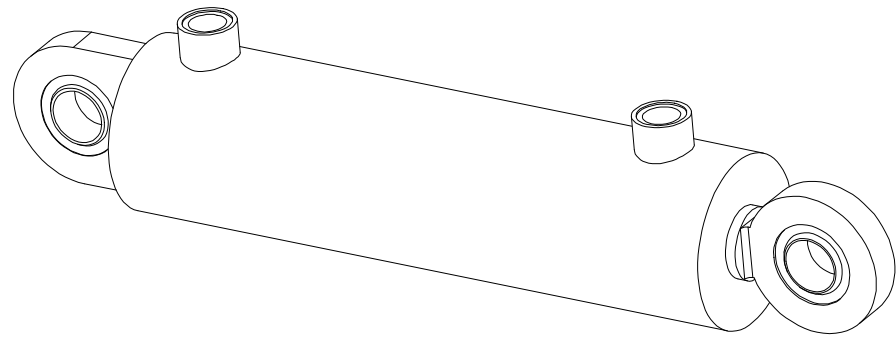

VZ00004549 - $\varnothing 80/\varnothing 40-250/455/705$

| Pos | Part number | Pcs |
|-----|-------------|-----|
| 1 | m20702 | 2 |

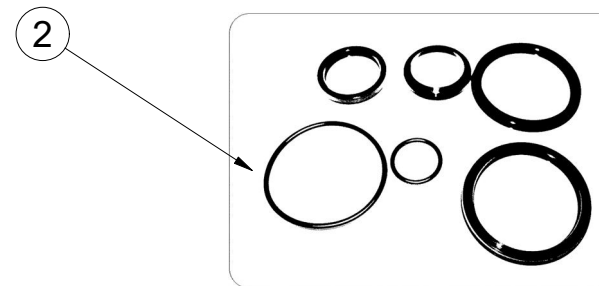
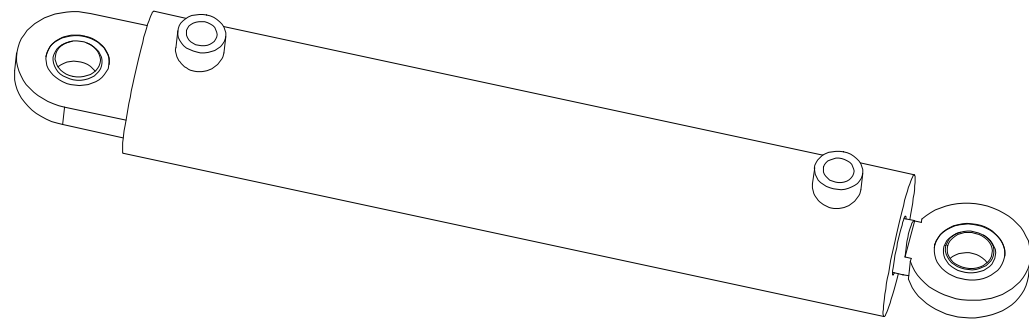

VZ00004544 - $\varnothing 80/\varnothing 40-400/605/1005$

| Pos | Part number | Pcs |
|-----|-------------|-----|
| 2 | m20702 | 2 |

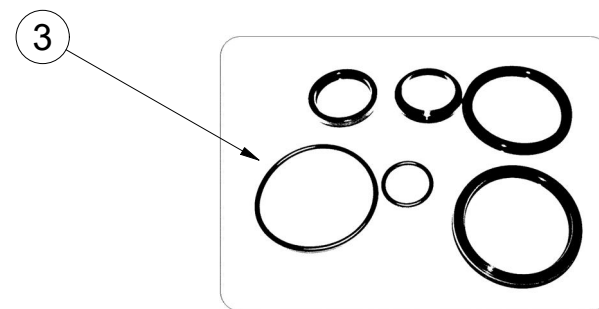
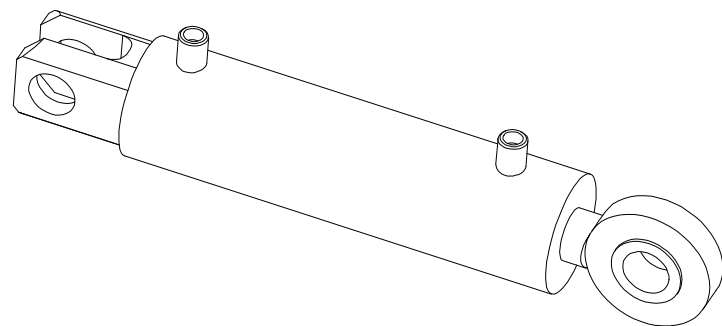

VZ00012974 - $\varnothing 40/\varnothing 22-100$

| Pos | Part number | Pcs |
|-----|-------------|-----|
| 3 | m20706 | 6 |

Ⓒ SVĚTELNÁ SADA

Ⓓ LEUCHTENSATZ

Ⓕ KIT LUMINEUX

Ⓖ LIGHTING SET

Ⓡ ОСВЕТИТЕЛЬНЫЙ КОМПЛЕКТ

Ⓟ ZESTAW OŚWIETLENIA



3012429

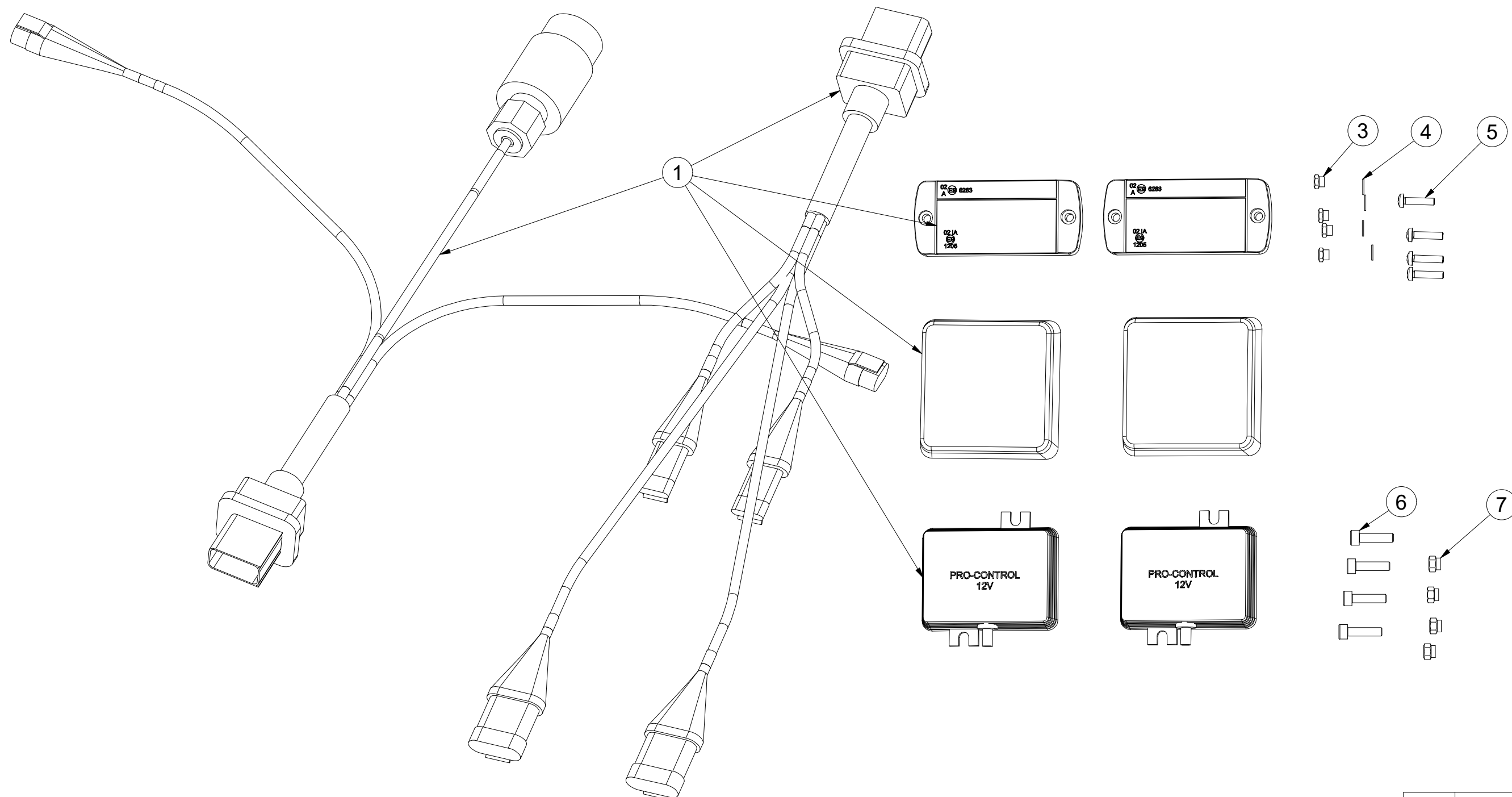

| Pos. | Part Number | Pcs. |
|------|-------------|------|
| 1 | m19043 | 1 |
| 3 | m05562 | 4 |
| 4 | m05597 | 4 |
| 5 | m15790 | 4 |
| 6 | m10591 | 4 |
| 7 | m06236 | 4 |

Ⓒ SVĚTELNÁ SADA

Ⓓ LEUCHTENSATZ

Ⓕ KIT LUMINEUX

Ⓖ LIGHTING SET

Ⓡ ОСВЕТИТЕЛЬНЫЙ КОМПЛЕКТ

Ⓟ ZESTAW OŚWIETLENIA

Farmet

3012429

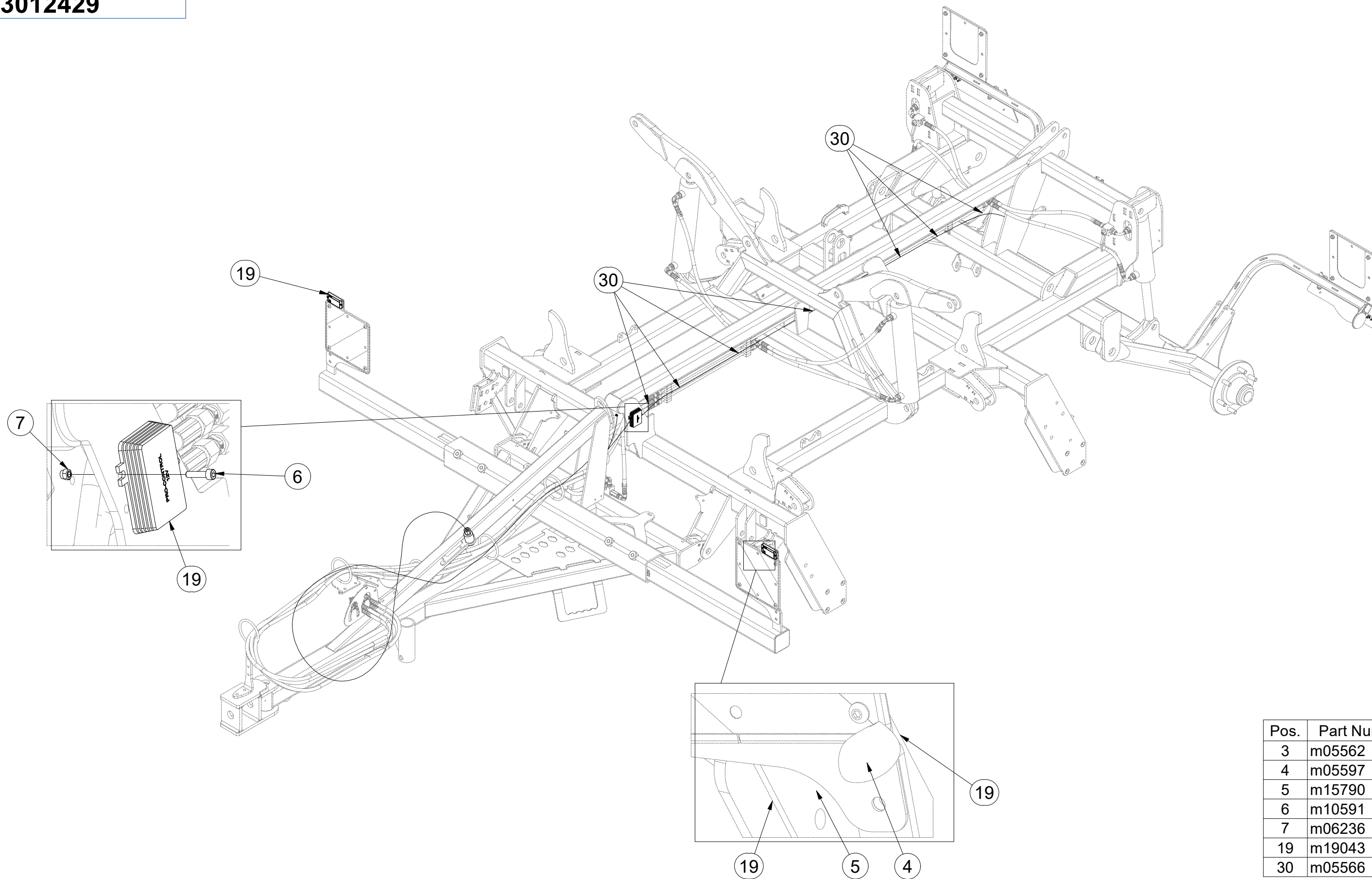

| Pos. | Part Number | Pcs. |
|------|-------------|------|
| 3 | m05562 | 4 |
| 4 | m05597 | 4 |
| 5 | m15790 | 4 |
| 6 | m10591 | 4 |
| 7 | m06236 | 4 |
| 19 | m19043 | 1 |
| 30 | m05566 | 50 |

Ⓒ SVĚTELNÁ SADA

Ⓓ LEUCHTENSATZ

Ⓕ KIT LUMINEUX

Ⓖ LIGHTING SET

Ⓡ ОСВЕТИТЕЛЬНЫЙ КОМПЛЕКТ

Ⓢ ZESTAW OŚWIETLENIA

Farmet

3012429

| Pos. | Part Number | Pcs. |
|------|-------------|------|
| 19 | m19043 | 1 |
| 30 | m05566 | 50 |

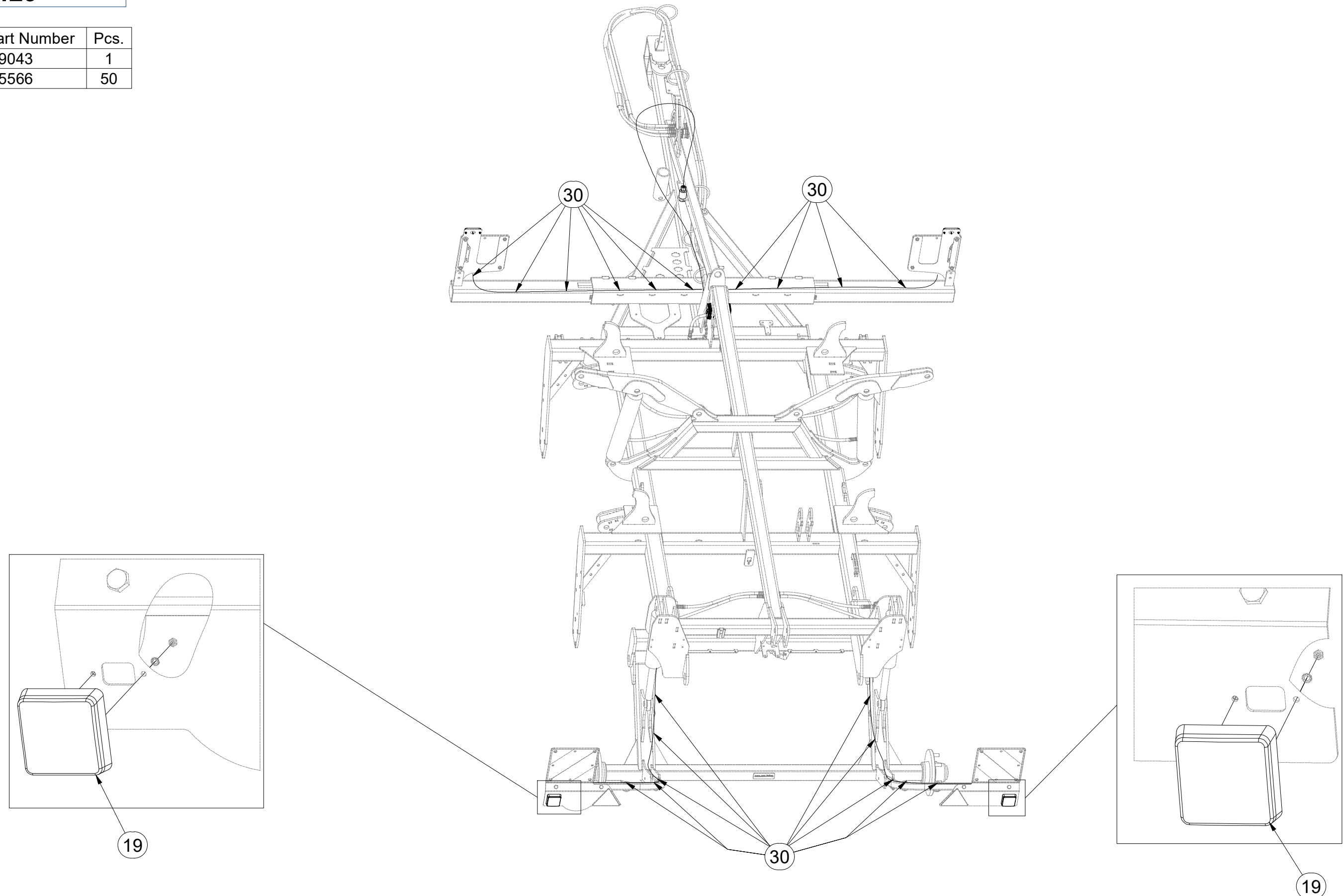

Ⓒ SVĚTELNÁ SADA

Ⓓ LEUCHTENSATZ

Ⓕ KIT LUMINEUX

Ⓖ LIGHTING SET

Ⓡ ОСВЕТИТЕЛЬНЫЙ КОМПЛЕКТ

Ⓟ ZESTAW OŚWIETLENIA



m19043

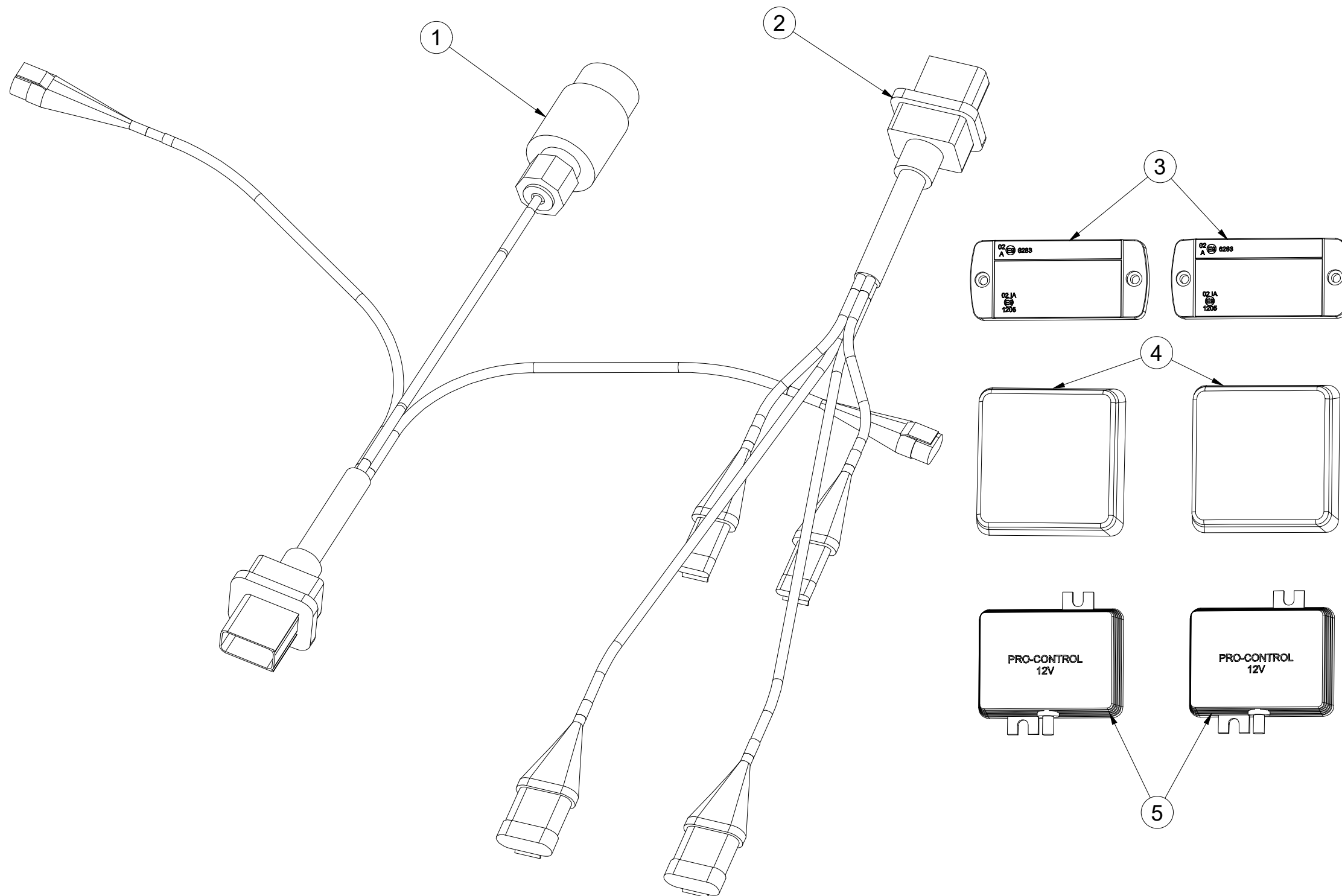

| Pos. | Part Number | Pcs. |
|------|-------------|------|
| 1 | m14779 | 1 |
| 2 | m14778 | 1 |
| 3 | m14776 | 2 |
| 4 | m19044 | 2 |
| 5 | m14777 | 2 |

- Ⓒ UTAHOVACÍ MOMENTY ŠROUBŮ
 Ⓓ ANZUGMOMENTE VON SCHRAUBEN
 Ⓕ COUPLES DE SERRAGE DES VIS

- Ⓒ SCREW TIGHTENING TORQUE
 Ⓓ МОМЕНТЫ ЗАЖАТИЯ БОЛТОВ
 Ⓕ MOMENTY DOKRĘCANIA ŚRUB



| P | | 5.8 | 8.8 | 10.9 | 12.9 | Z | |
|-----|------|------|------|-------|-------|----------|-----------|
| D | R | Mu | Mu | Mu | Mu | DIN 7991 | ISO 10642 |
| mm | mm | Nm | Nm | Nm | Nm | Nm | Nm |
| M6 | 1 | 6 | 9 | 13 | 15 | 7,2 | 7,9 |
| M8 | 1,25 | 14 | 22 | 32 | 38 | 17 | 19 |
| M10 | 1,5 | 29 | 44 | 64 | 75 | 35 | 38 |
| M12 | 1,75 | 49 | 76 | 111 | 130 | 58 | 65 |
| M14 | 2 | 79 | 120 | 176 | 206 | 93 | 100 |
| M16 | 2 | 123 | 188 | 276 | 323 | 144 | 158 |
| M18 | 2,5 | 169 | 257 | 378 | 443 | - | 220 |
| M20 | 2,5 | 239 | 365 | 536 | 628 | - | 310 |
| M22 | 2,5 | 329 | 529 | 738 | 864 | - | 420 |
| M24 | 3 | 413 | 629 | 924 | 1082 | - | 530 |
| M27 | 3 | 613 | 934 | 1372 | 1606 | - | - |
| M30 | 3,5 | 832 | 1267 | 1862 | 2179 | - | - |
| M33 | 3,5 | 1130 | 1723 | 2530 | 2961 | - | - |
| M36 | 4 | 1451 | 2210 | 3246 | 3799 | - | - |
| M39 | 4 | 1885 | 2872 | 4217 | 4936 | - | - |
| M42 | 4,5 | 2322 | 3538 | 5196 | 6080 | - | - |
| M45 | 4,5 | 2909 | 4433 | 6511 | 7619 | - | - |
| M48 | 5 | 3513 | 535 | 7862 | 9200 | - | - |
| M52 | 5 | 4524 | 6895 | 10123 | 11849 | - | - |
| M56 | 5,5 | 5636 | 8589 | 12614 | 14761 | - | - |

- Mu - Ⓒ UTAHOVACÍ MOMENT
 Ⓓ ANZUGMOMENTE
 Ⓕ COUPLE DE SERRAGE
 Ⓒ TIGHTENING TORQUE
 Ⓓ МОМЕНТ ЗАЖАТИЯ
 Ⓕ MOMENT DOKRĘCANIA
- D - Ⓒ JMENOVITÝ PRŮMĚR
 Ⓓ NENNDURCHMESSER
 Ⓕ DIAMETRE NOMINAL
 Ⓒ NOMINAL DIAMETER
 Ⓓ НОМИНАЛЬНЫЙ ДИАМЕТР
 Ⓕ ŚREDNICA NOMINALNA
- R - Ⓒ ROZTEČ ZÁVITU - STOUPÁNÍ
 Ⓓ GEWINDESTEIFUNG
 Ⓕ PAS DE FILET - PAS
 Ⓒ SCREW PITCH – LEAD
 Ⓓ ШАГ РЕЗЬБЫ
 Ⓕ ROZSTAW GWINTU - SKOKI
- P - Ⓒ PEVNOST
 Ⓓ FESTIGKEIT
 Ⓕ RÉSISTANCE
 Ⓒ STRENGTH
 Ⓓ ПРОЧНОСТЬ
 Ⓕ WYTRZYMA OŚĆ
- Z - Ⓒ ZÁPUSTNÉ ŠROUBY
 Ⓓ SENKKOPFSCHRAUBEN
 Ⓕ VIS A TETE FRAISEE
 Ⓒ COUNTERSUNK SCREWS
 Ⓓ БОЛТЫ С УТОПЛЕННОЙ ГОЛОВКОЙ
 Ⓕ ŚRUBY Z ŁBEM STOŻKOWYM PŁASKIM

- Ⓒ Hodnoty momentů jsou poníženy o -10% oproti tabulkovým hodnotám. Šroubové spoje utahujte dle vyznačeného utahovacího momentu v dokumentaci. Pokud není utahovací moment v dokumentaci vyznačen, utahujte dle obecné tabulky. Pokud je v dokumentaci definován spoj šroubu a matice o různých pevnostech, vždy utahujte na moment komponenty nižší.
- Ⓓ Die Werte der Anzugsmomente sind um 10 % gegenüber den Tabellenwerten verringert. Ziehen Sie die Schraubverbindungen gemäß dem in der Dokumentation festgeschriebenen Anzugsmoment an. Sofern das Anzugsmoment nicht in der Dokumentation aufgeführt ist, ziehen Sie sie gemäß der allgemeinen Tabelle an. Wenn in der Dokumentation eine Verbindung von Schraube und Mutter mit verschiedene Festigkeiten definiert ist, wird immer mit dem Moment des Bauteils mit der geringeren Festigkeit angezogen.
- Ⓕ Les valeurs des couples de serrage sont baissées de 10% par rapport aux valeurs de tableau. Serrez les raccords à vis selon le couple de serrage indiqué dans les documents. Si le couple de serrage n'est pas indiqué dans les documents, serrez selon le tableau général. Si les documents définissent un assemblage par boulon de diverses résistances, serrez toujours au moment de la composante avec résistance inférieure.
- Ⓒ The torque values are reduced by 10% compared to the table values. Tighten the screw joints according to the tightening torque stated in the documentation. If the tightening torque is not stated in the documentation, tighten according to the general table. If there is a joint with a screw and a nut at different strengths in the documentation, always tighten to the torque of the component with lower strength.
- Ⓓ Значения моментов затяжки уменьшены на 10% по сравнению с данными в таблице. Резьбовые соединения зажимайте с установленным в документации моментом зажатия. Если в документации не указан момент зажатия, то зажимайте по действующей в общем таблице. Если в документации установлено соединение из болта и гайки различной прочности, всегда зажимайте с моментом для компонента с меньшей прочностью.
- Ⓕ Wartości momentów dokręcania są obniżone o 10% w stosunku do wartości z tabeli. Połączenia śrubowe należy dokręcać zgodnie z momentem obrotowym w dokumentacji. Jeśli w dokumentacji nie ma podanego momentu obrotowego, należy dokręcać zgodnie z ogólną tabelą. Jeśli w dokumentacji zdefiniowane jest połączenie ze śrubą nakrętką różnych wytrzymałościach, zawsze należy dokręcać zachowując moment dokręcania komponentu z niższą wytrzymałością.

- Ⓒ UTAHOVACÍ MOMENTY ŠROUBŮ
 Ⓓ ANZUGMOMENTE VON SCHRAUBEN
 Ⓕ COUPLES DE SERRAGE DES VIS

- Ⓖ SCREW TIGHTENING TORQUE
 Ⓡ MOMENTЫ ЗАЖАТИЯ БОЛТОВ
 Ⓟ MOMENTY DOKRĘCANIA ŚRUB



- Ⓒ **OBECNÝ PŘEDPIS UTAHOVÁNÍ ZAJIŠTĚNÍ ČEPOVÝCH SPOJŮ:**
 Ⓓ **ALLGEMEINE VORSCHRIFT FÜR DAS ANZIEHEN VON BOLZENVERBINDUNGEN:**
 Ⓕ **CONSIGNE GENERALE POUR LE SERRAGE DES ARTICULATIONS CYLINDRIQUES:**
 Ⓖ **GENERAL INSTRUCTION FOR TIGHTENING THE SECURING OF PIN JOINTS:**
 Ⓡ **ОБЩЕЕ ОПИСАНИЕ ЗАЖАТИЯ ПРЕДОХРАНЕНИЯ СОЕДИНЕНИЙ ПАЛЬЦАМИ:**
 Ⓟ **OGÓLNE ZASADY DOKRĘCANIA ZABEZPIECZENIA POŁĄCZEŃ CZOPEM:**



X

M8, M10, M12

M14

M

09-15Nm

15-25Nm

- X - Ⓒ ROZMĚR ŠROUBU
 Ⓓ SCHRAUBENGRÖSSE
 Ⓕ DIMENSIONS DE LA VIS

- Ⓖ BOLT DIMENSION
 Ⓡ РАЗМЕР БОЛТА
 Ⓟ ROZMIAR ŚRUBY

- M - Ⓒ ORIENTAČNÍ MOMENT
 Ⓓ ANZUGSMOMENT
 Ⓕ COUPLE D'ORIENTATION

- Ⓖ ORIENTATION TORQUE
 Ⓡ ОРИЕНТАЦИОННЫЙ МОМЕНТ
 Ⓟ ORIENTACYJNY MOMENT

- Ⓒ Tyto spoje není nutné ověřovat kontrolou momentovým klíčem = stačí vizuálně kontrolovat sešroubování.
 Ⓓ Diese Verbindungen müssen nicht mit einem Drehmomentschlüssel überprüft werden = es genügt, die Verschraubung visuell zu kontrollieren.
 Ⓕ Il n'est pas nécessaire de contrôler le serrage à l'aide d'une clé dynamométrique = un contrôle visuel de l'assemblage suffit.
 Ⓖ These joints do not have to be verified by checking with a torque wrench = visual inspection of bolting is sufficient.
 Ⓡ Эти соединения не нужно контролировать динамометрическим ключом = достаточно визуально проверять прикручивание.
 Ⓟ Nie trzeba sprawdzać tych połączeń kluczem dynamometrycznym = wystarczy wizualnie skontrolować dokręcenie.