

The effective technology

# Farmet®

ⒸZ KATALOG NÁHRADNÍCH DÍLŮ ⒸB CATALOGUE OF SPARE PARTS ⒸD ERSATZTEILLISTE  
ⒸRU КАТАЛОГ ЗАПАСНЫХ ЧАСТЕЙ ⒸF CATALOGUE DES PIÈCES DE RECHANGE ⒸPL KATALOG CZĘŚCI ZAMIENNYCH

## SOFTER 9 PSW

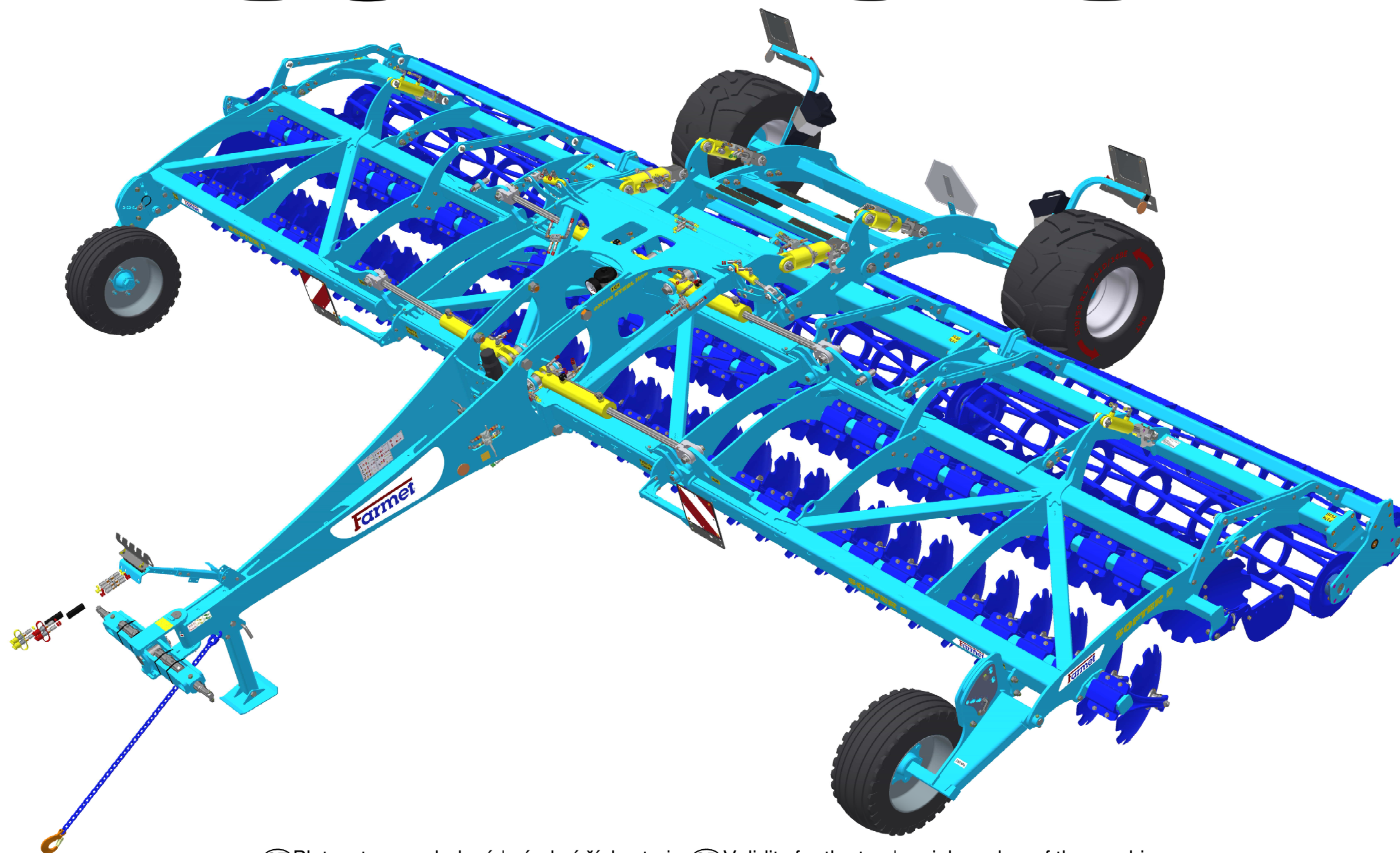

ⒸZ Platnost pro vrcholové | výrobní číslo stroje ⒸB Validity for the top | serial number of the machine  
ⒸD Gültigkeit für die Haupt- | Herstellungsnummer der Maschine ⒸRU Действительно для главного | заводского номера машины  
ⒸF Validité du numéro de référence | de série de la machine ⒸPL Obowiązuje dla numeru głównego | seryjnego maszyny

9316979 | 2022/0841

Farmet a. s.  
Jiřinková 276  
552 03 Česká Skalice, CZ

telefon: +420 491 450 111  
fax: +420 491 450 136  
GSM: +420 774 715 738

IČ: 46504931  
DIČ: CZ46504931

web: [www.farmet.cz](http://www.farmet.cz)  
e-mail: [farmet@farmet.cz](mailto:farmet@farmet.cz)

ⒸZ NAVIGACE STROJE

ⒸD NAVIGATION DER MASCHINE

ⒸF NAVIGATION DE LA MACHINE

ⒸGB NAVIGATION OF THE MACHINE

ⒸRU НАВИГАЦИЯ МАШИНЫ

ⒸPL NAWIGACJA MASZYNY

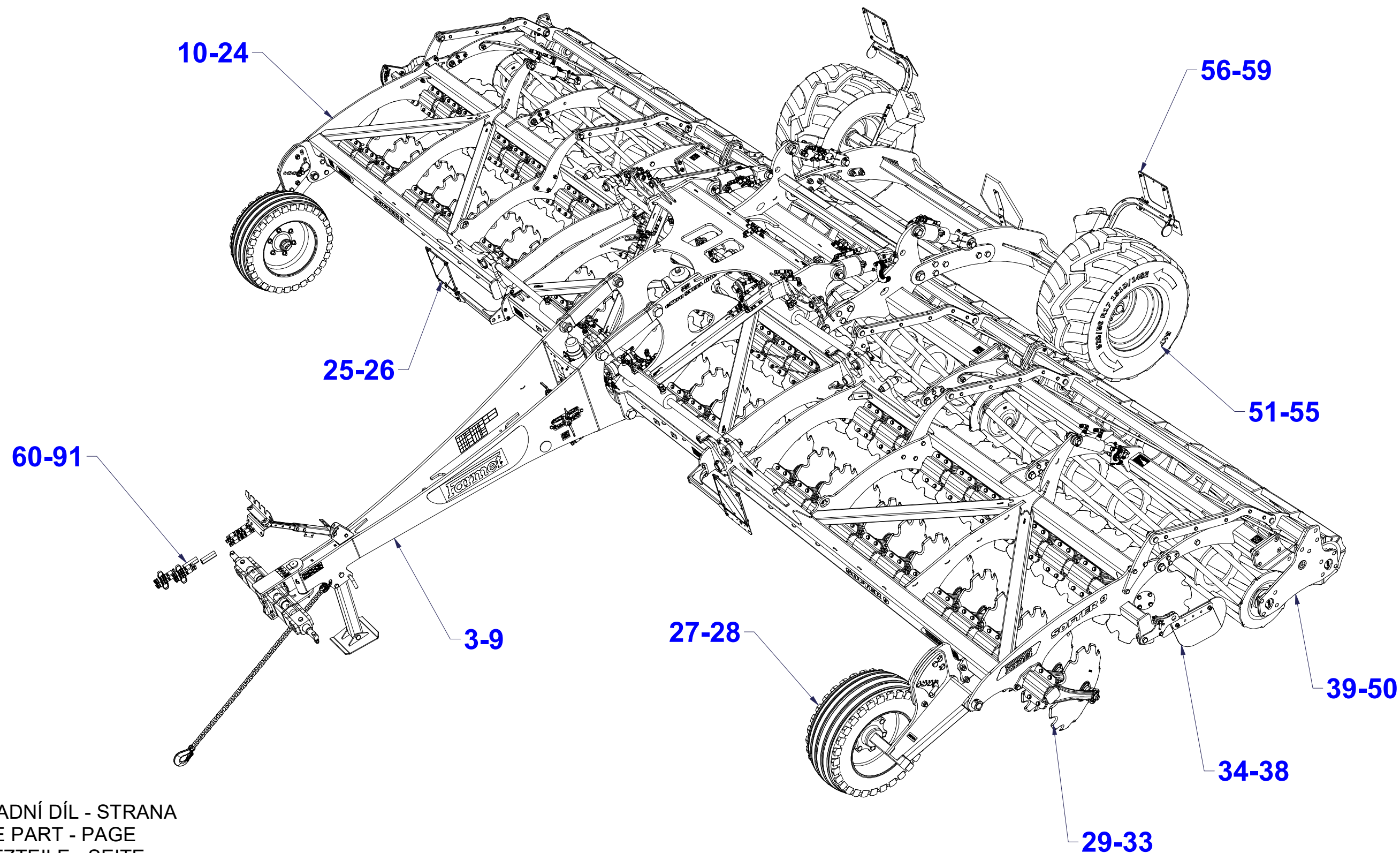

ⒸZ NÁHRADNÍ DÍL - STRANA

ⒸGB SPARE PART - PAGE

ⒸD ERSATZTEILE - SEITE

ⒸRU ЗАПЧАСТЬ - СТРАНИЦА

ⒸF PIÈCE DE RECHANGE - PAGE

ⒸPL CZĘŚCI ZAMIENNE - STRONA

ⒸZ OJ MONT

Ⓓ DEICHSEL MONTIERT

Ⓕ TIMON MONTÉ

**VZ00003662**

ⒼB MONT DRAWBAR

ⒺU ДЫШЛО МОНТ.

ⒶL DYSZEL MONT

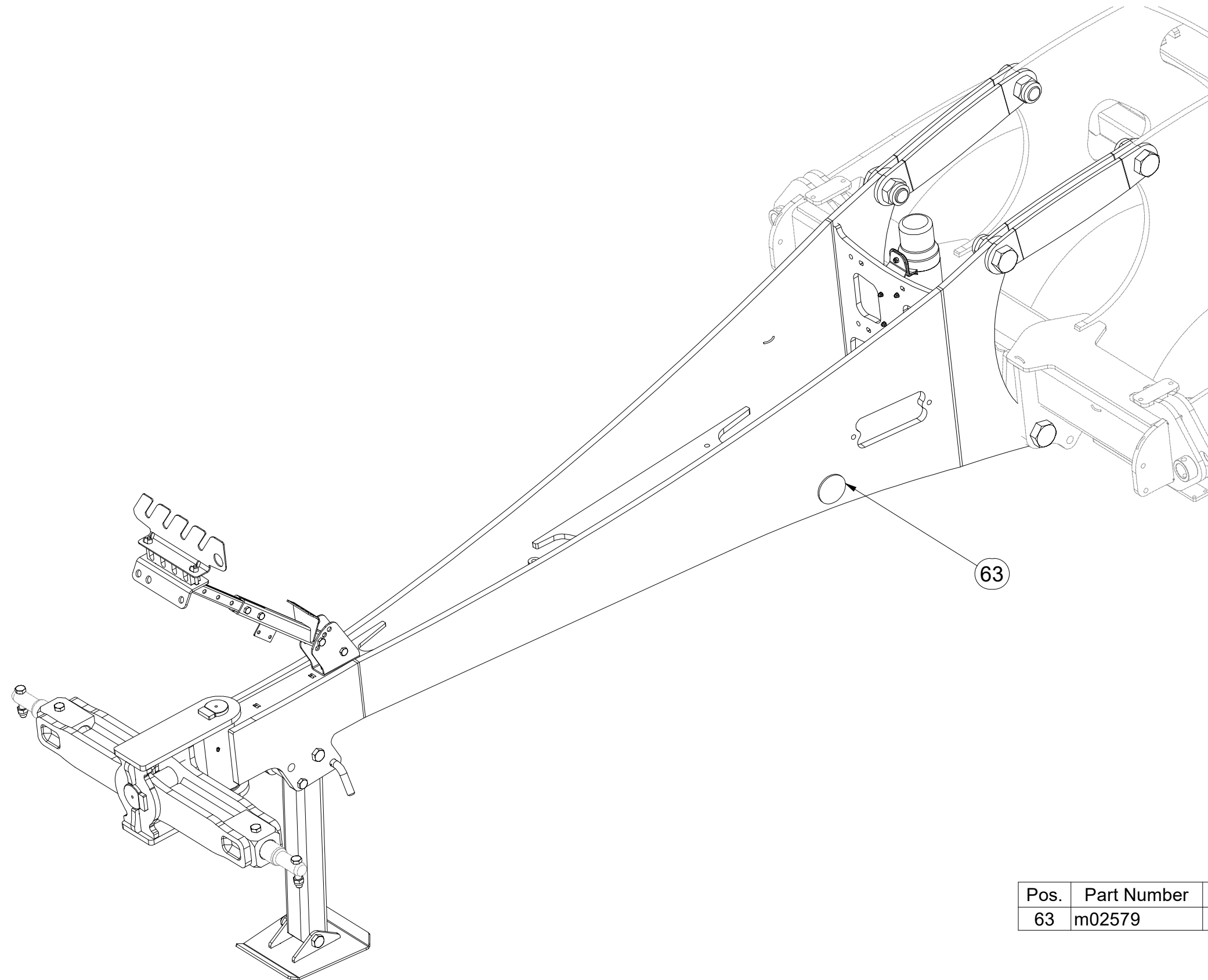

Pos.	Part Number	Pcs.
63	m02579	2

Ⓒ OJ MONT

Ⓓ DEICHSEL MONTIERT

Ⓕ TIMON MONTÉ

Ⓖ MONT DRAWBAR

Ⓡ ДЫШЛО МОНТ.

Ⓢ DYSZEL MONT



**VZ00003662**

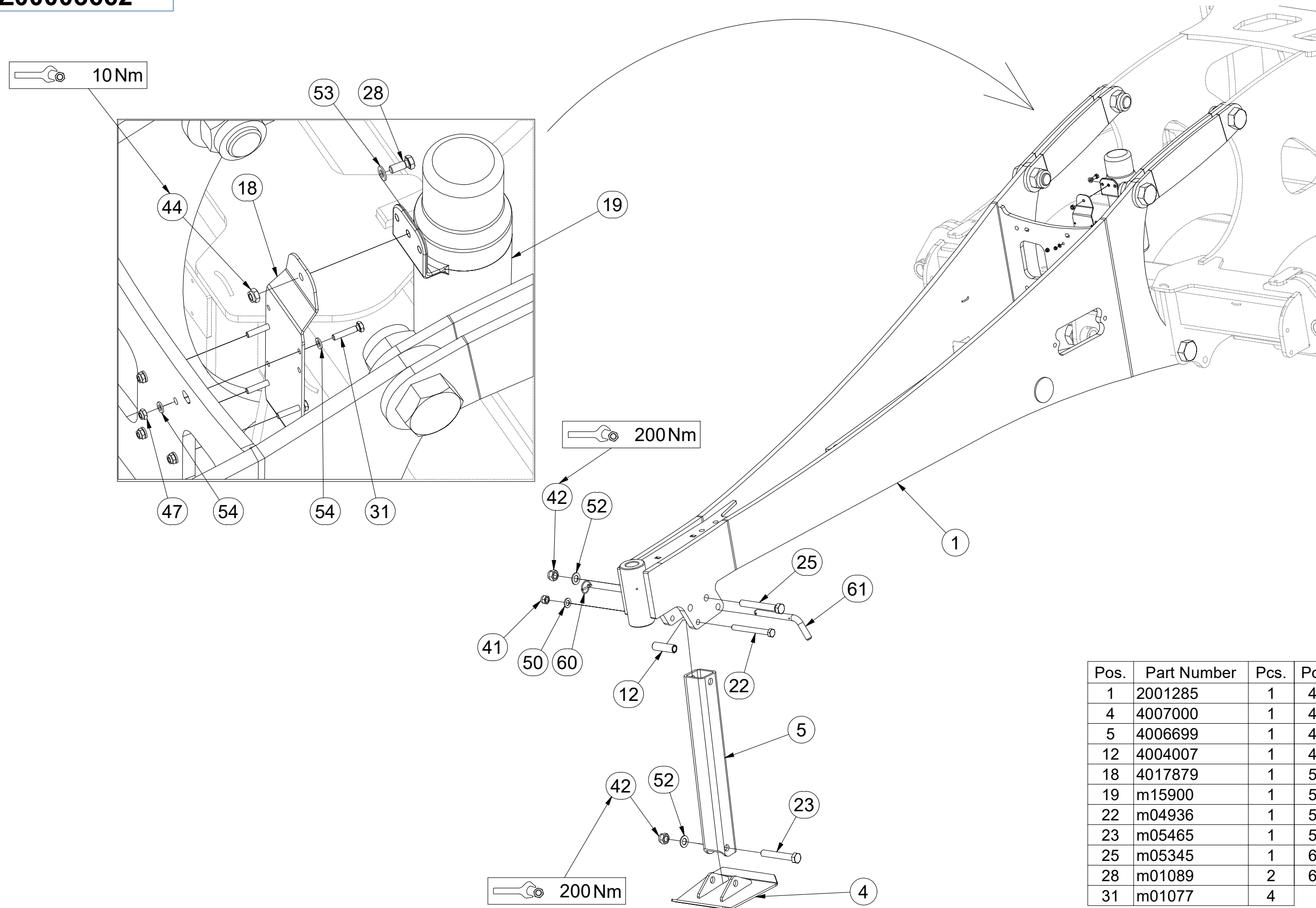

Pos.	Part Number	Pcs.	Pos.	Part Number	Pcs.
1	2001285	1	41	m03683	7
4	4007000	1	42	m05648	2
5	4006699	1	44	m04503	2
12	4004007	1	47	m05560	4
18	4017879	1	50	m01219	1
19	m15900	1	52	m03768	2
22	m04936	1	53	m01203	2
23	m05465	1	54	m01199	8
25	m05345	1	60	m10454	1
28	m01089	2	61	m18629	1
31	m01077	4			

ⒸZ OJ MONT

Ⓓ DEICHSEL MONTIERT

Ⓕ TIMON MONTÉ

**VZ00003662**

ⒼB MONT DRAWBAR

ⒺU ДЫШЛО МОНТ.

ⒼL DYSZEL MONT

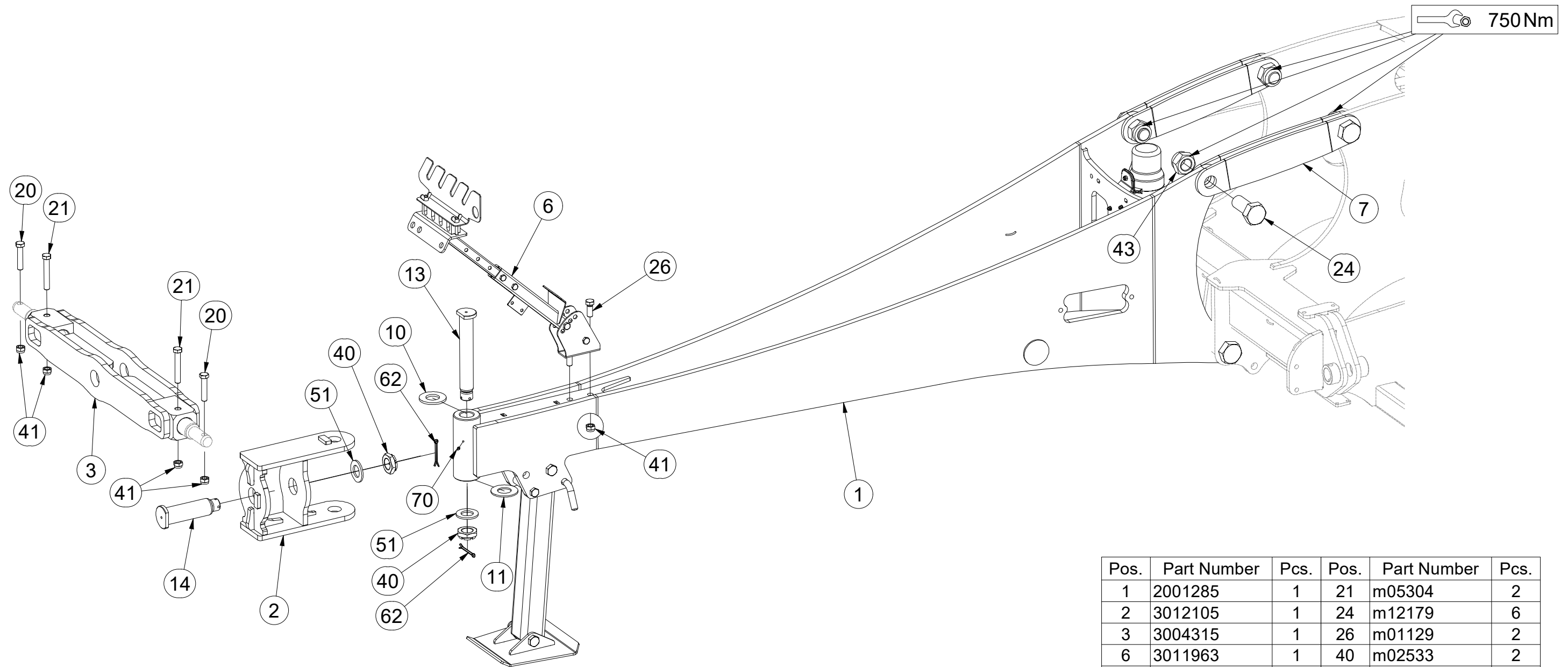

Pos.	Part Number	Pcs.	Pos.	Part Number	Pcs.
1	2001285	1	21	m05304	2
2	3012105	1	24	m12179	6
3	3004315	1	26	m01129	2
6	3011963	1	40	m02533	2
7	4014721	4	41	m03683	7
10	4003745	1	43	m11337	6
11	4003744	1	51	m03866	2
13	4007817	1	62	m04139	2
14	4007818	1	70	m01725	1
20	m01133	2			

CZ TELESKOPICKÝ DRŽÁK HADIC  
 D TELESKOPSCHLAUCHHALTER  
 F SUPPORT DE TUYAU TÉLESCOPIQUE

GB TELESCOPIC HOSE HOLDER  
 RU ТЕЛЕСКОПИЧЕСКИЙ ДЕРЖАТЕЛЬ ШЛАНГА  
 PL TELESKOPOWY UCHWYT NA WAŻ



**3011963**

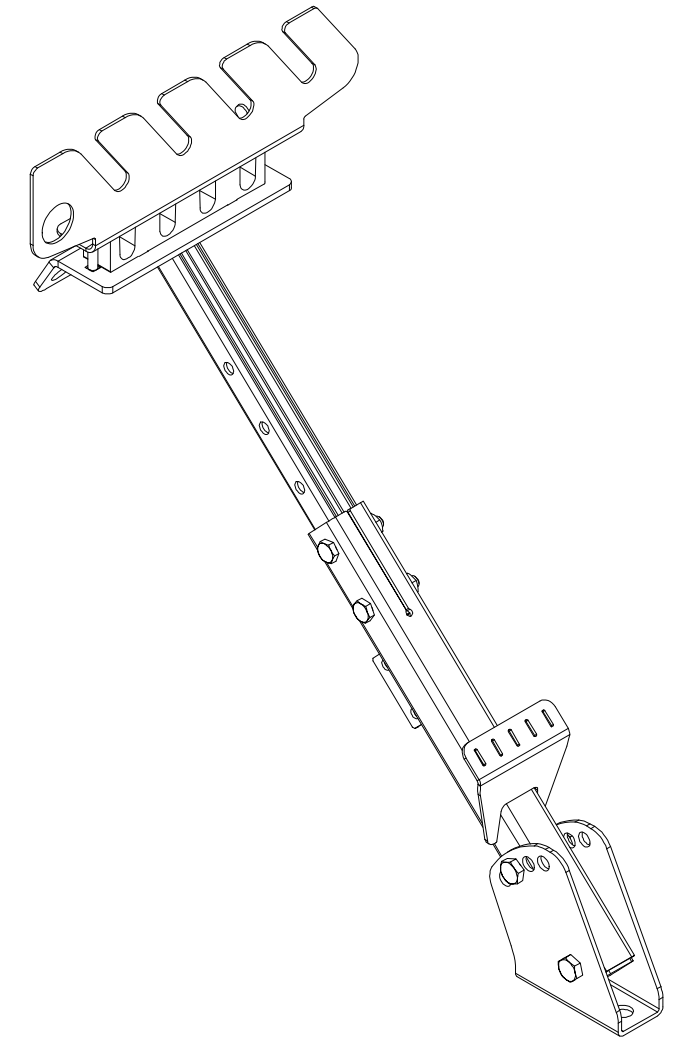
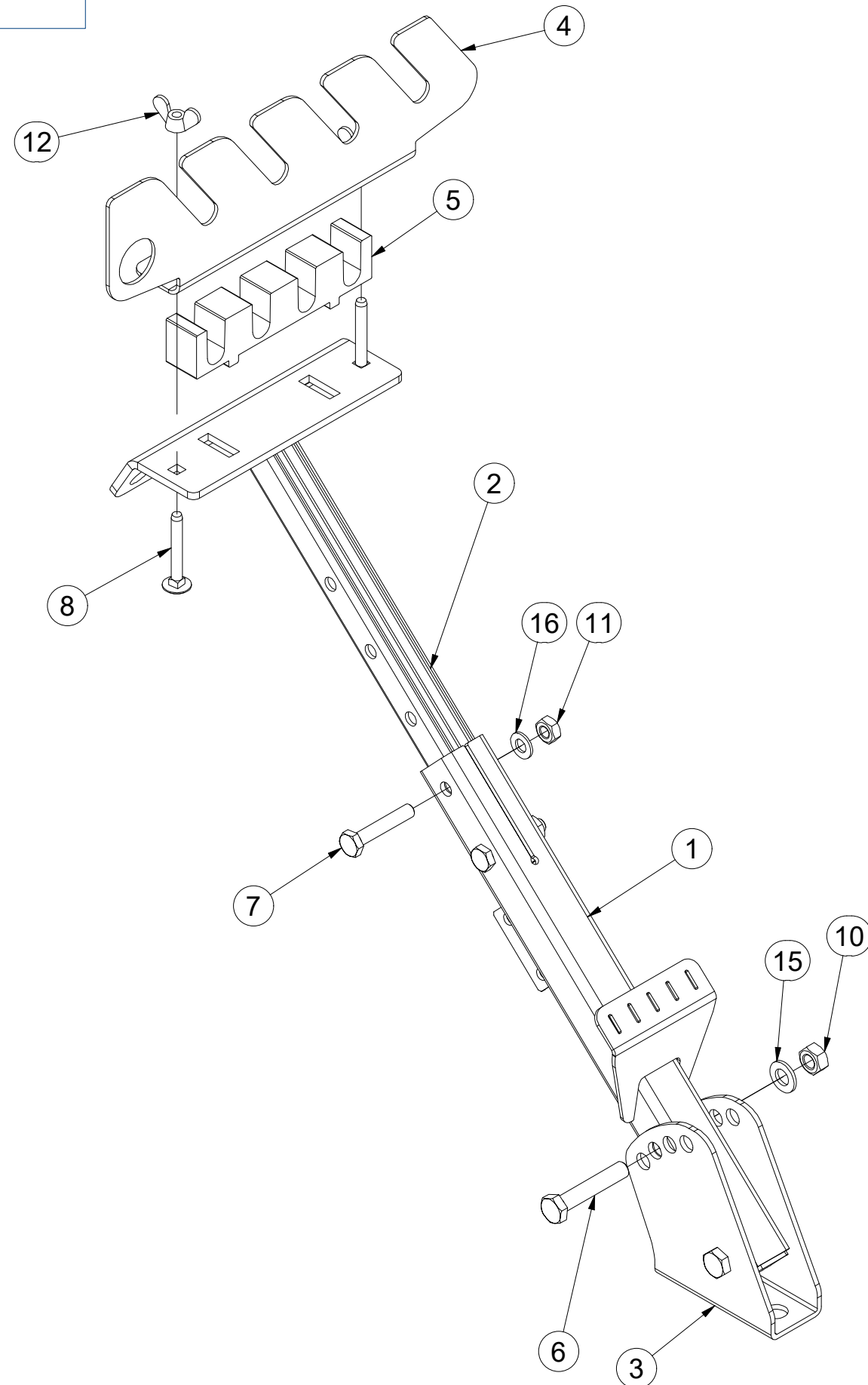

Pos.	Part Number	Pcs.
1	3011662	1
2	3011689	1
3	3011659	1
4	4023572	1
5	m22642	1
6	m05898	2
7	m06253	2
8	m09247	2
10	m01305	2
11	m01299	2
12	m01316	2
15	m01214	2
16	m01209	2

Ⓒ SADA ČEPŮ TBZ 3

Ⓓ BOLZENSATZ TBZ 3

Ⓕ KIT D'EMBOUTS TBZ 3

**4020780**

Ⓖ SET OF TBZ 3 PINS

Ⓡ КОМПЛЕКТ ПАЛЬЦЕВ TBZ 3

Ⓟ ZESTAW CZOPÓW TBZ 3

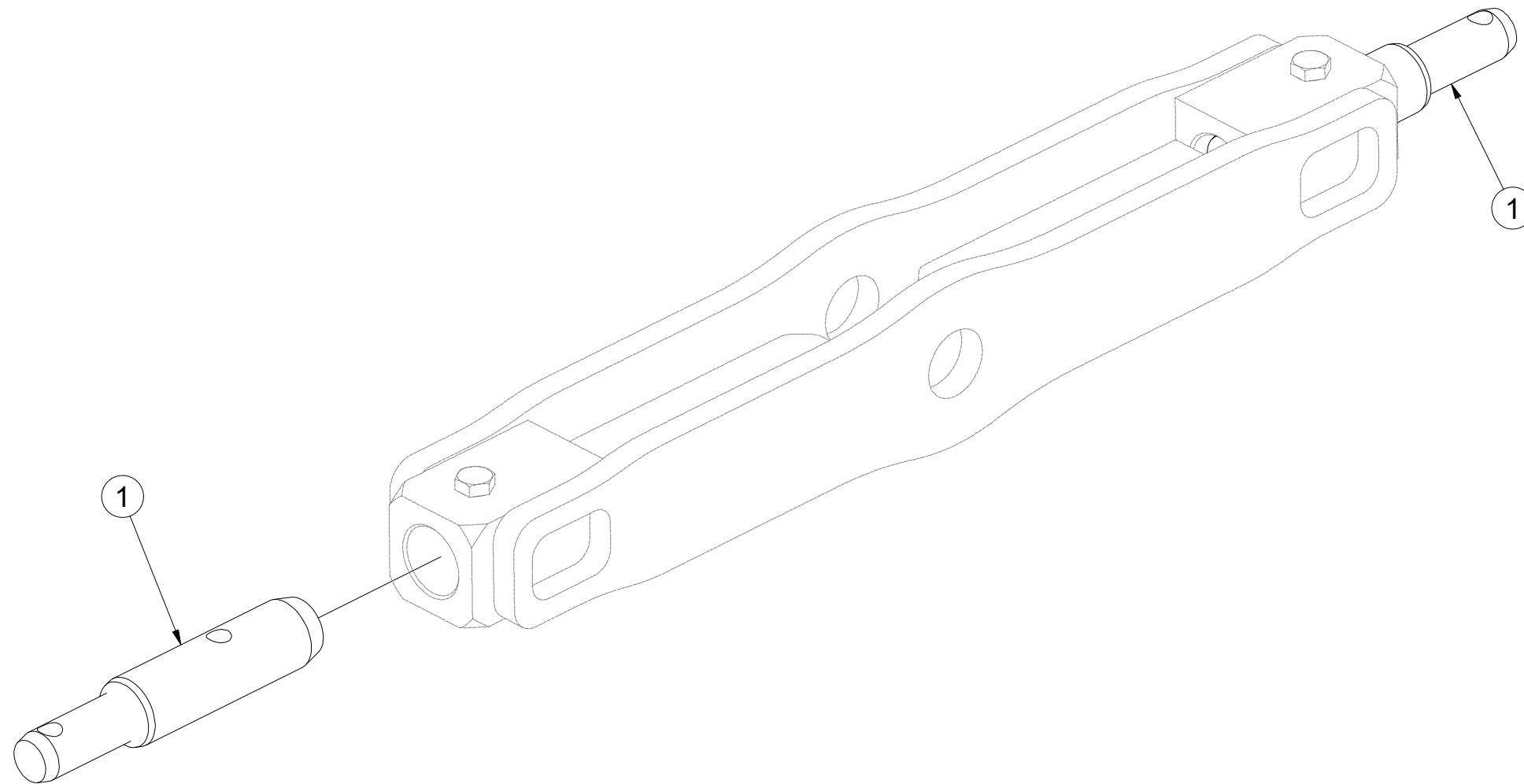

Pos.	Part Number	Pcs.
1	VZ00022883	2

- Ⓒ SADA ČEPŮ T4
- Ⓓ BOLZENSATZ T4
- Ⓕ KIT D'EMBOUTS T4

- Ⓖ SET OF T4 PINS
- Ⓡ КОМПЛЕКТ ПАЛЬЦЕВ T4
- Ⓟ ZESTAW CZOPÓW T4



**4016857**

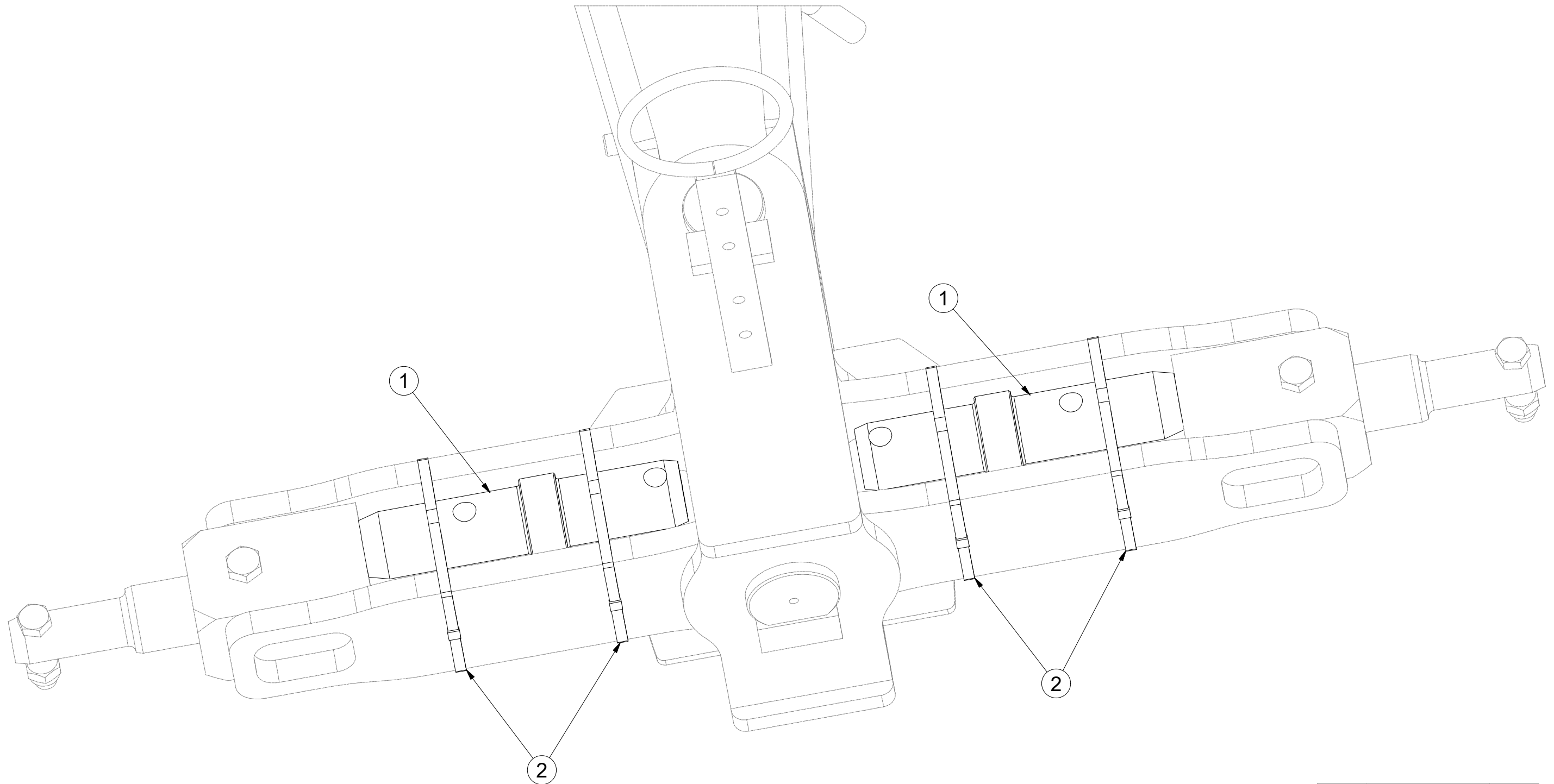

Pos.	Part Number	Pcs.
1	4008588	2
2	m01637	4



ⒸZ ŘETĚZ  
Ⓓ KETTE  
Ⓕ CHAÎNE

ⒸGB CHAIN  
ⒸRU ЦЕПЬ  
ⒸPL ŁAŃCUCH



VZ00026877

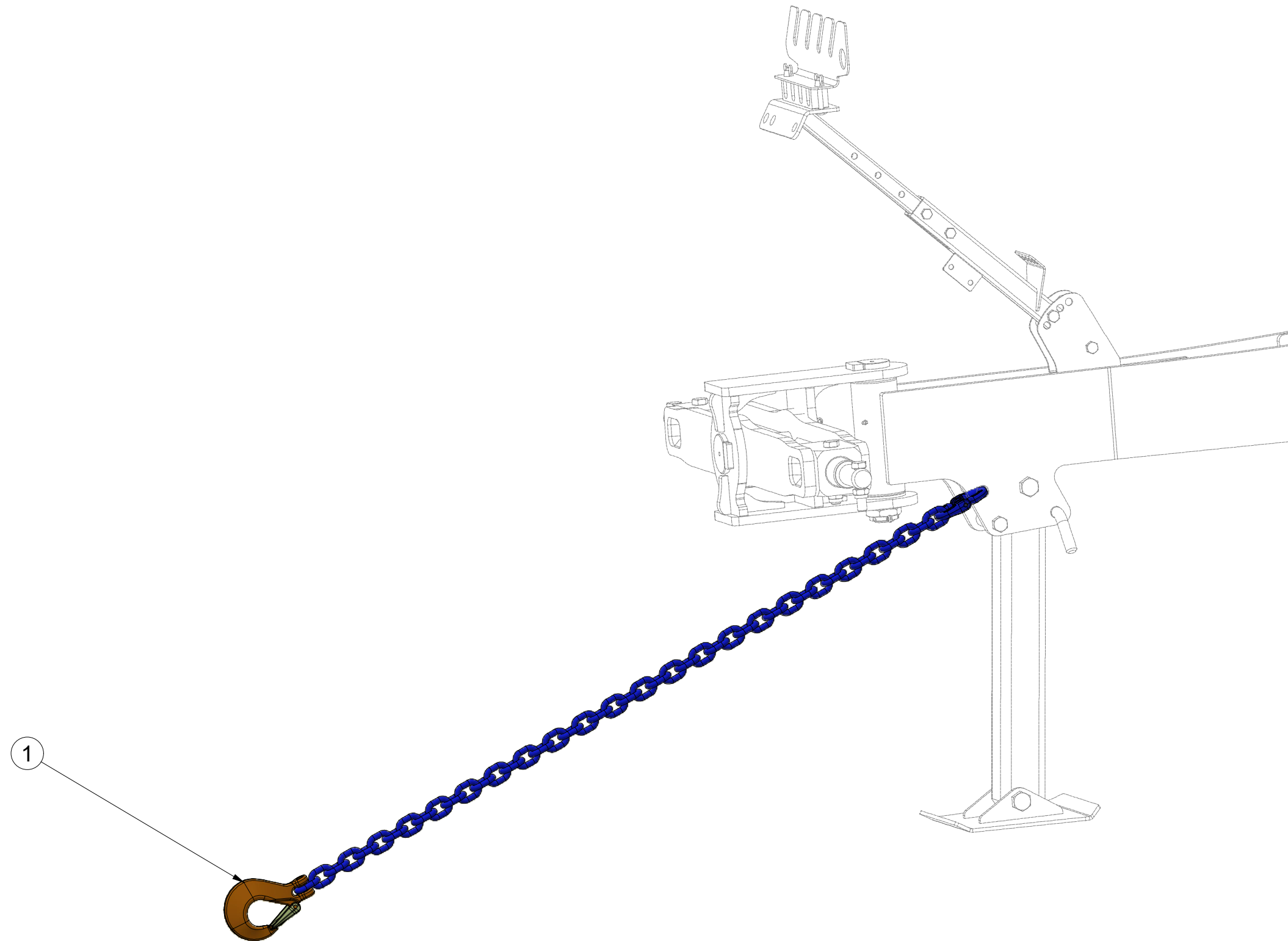

Pos.	Part Number	Pcs.
1	m22949	1

Ⓒ ZÁKLAD STROJE

Ⓓ UNTERBAU DER MASCHINE

Ⓕ BÂTI DE LA MACHINE

**VZ00016796**

Ⓖ FOOTING OF THE MACHINE

Ⓡ ОСНОВАНИЕ МАШИНЫ

Ⓟ PODSTAWA MASZYNY

**Farmet**

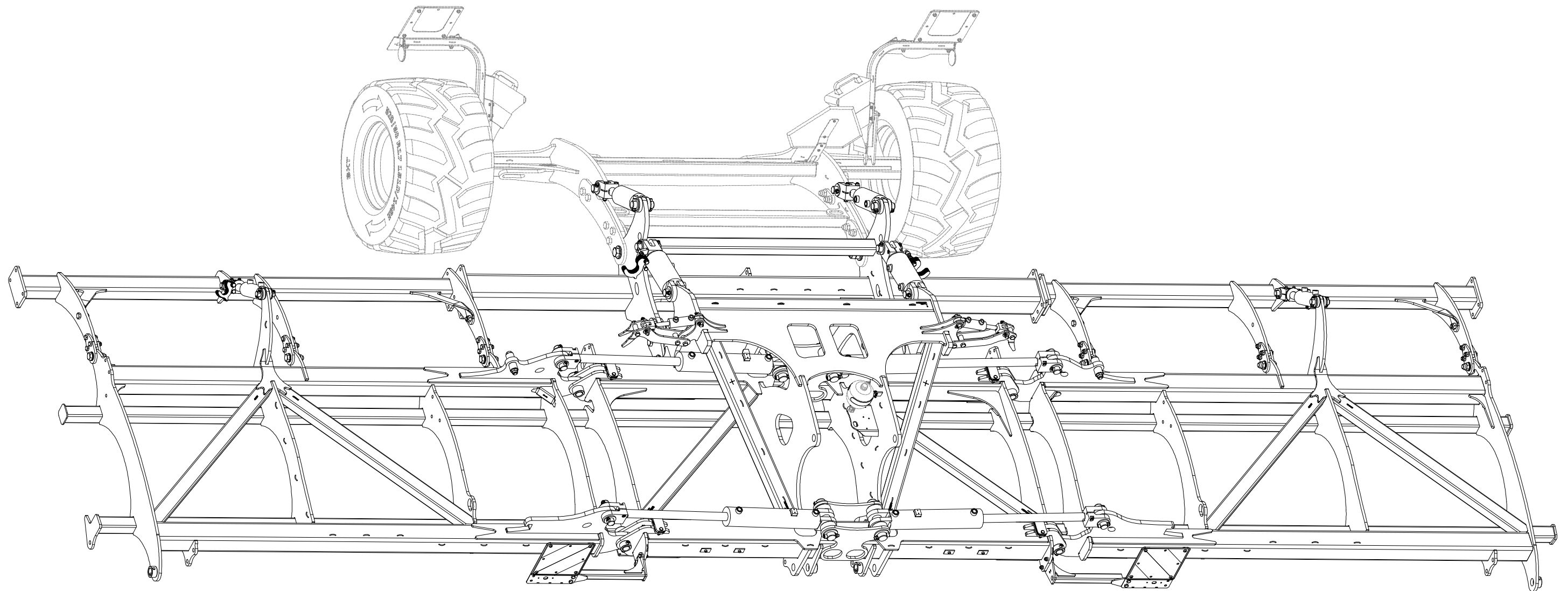

Ⓒ ZÁKLAD STROJE

Ⓓ UNTERBAU DER MASCHINE

Ⓕ BÂTI DE LA MACHINE

**VZ00016796**

Ⓖ FOOTING OF THE MACHINE

Ⓡ ОСНОВАНИЕ МАШИНЫ

Ⓢ PODSTAWA MASZYNY

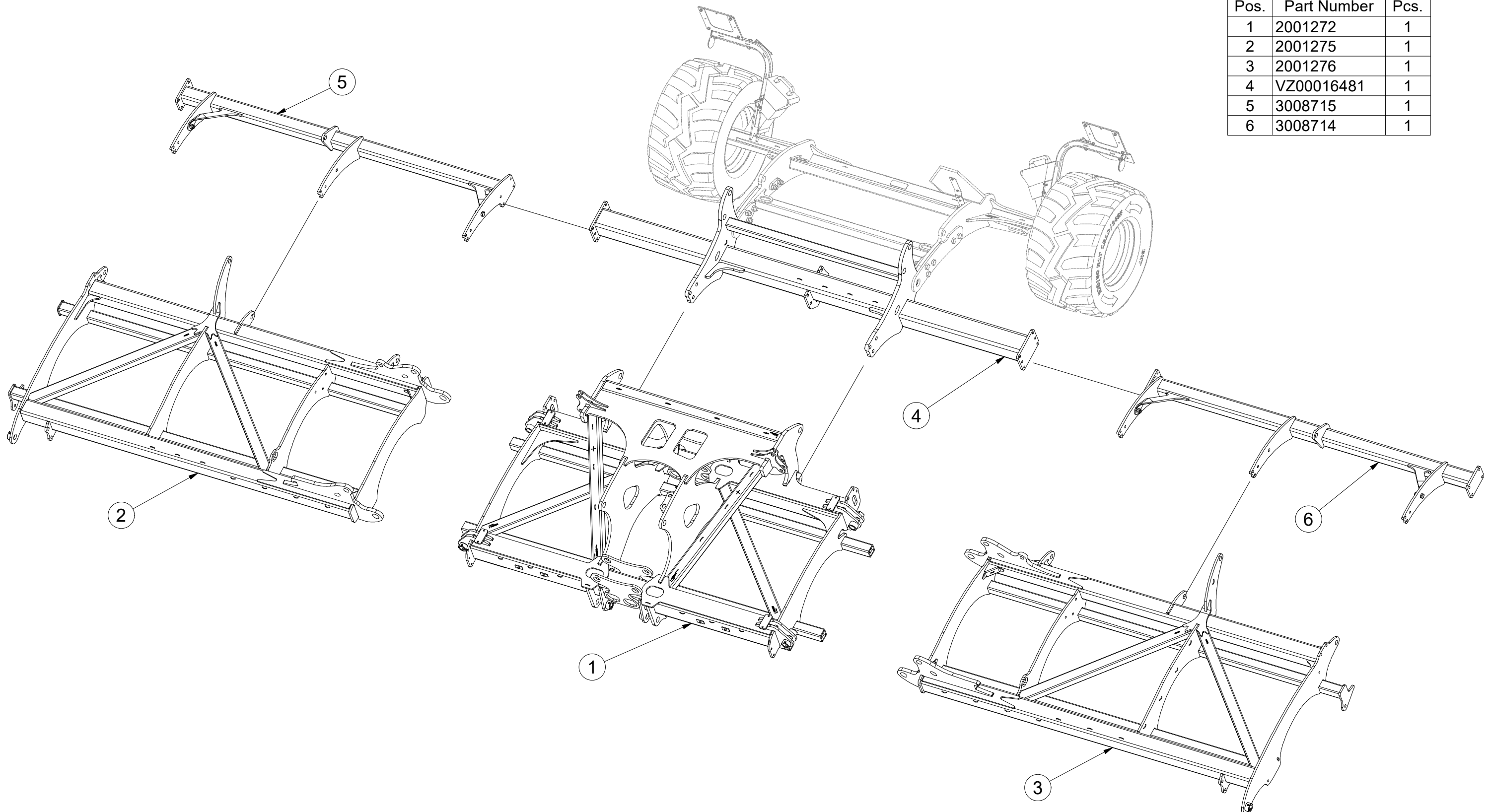

Pos.	Part Number	Pcs.
1	2001272	1
2	2001275	1
3	2001276	1
4	VZ00016481	1
5	3008715	1
6	3008714	1

Ⓒ ZÁKLAD STROJE

Ⓓ UNTERBAU DER MASCHINE

Ⓕ BÂTI DE LA MACHINE

Ⓖ FOOTING OF THE MACHINE

Ⓡ ОСНОВАНИЕ МАШИНЫ

Ⓟ PODSTAWA MASZYNY



**VZ00016796**

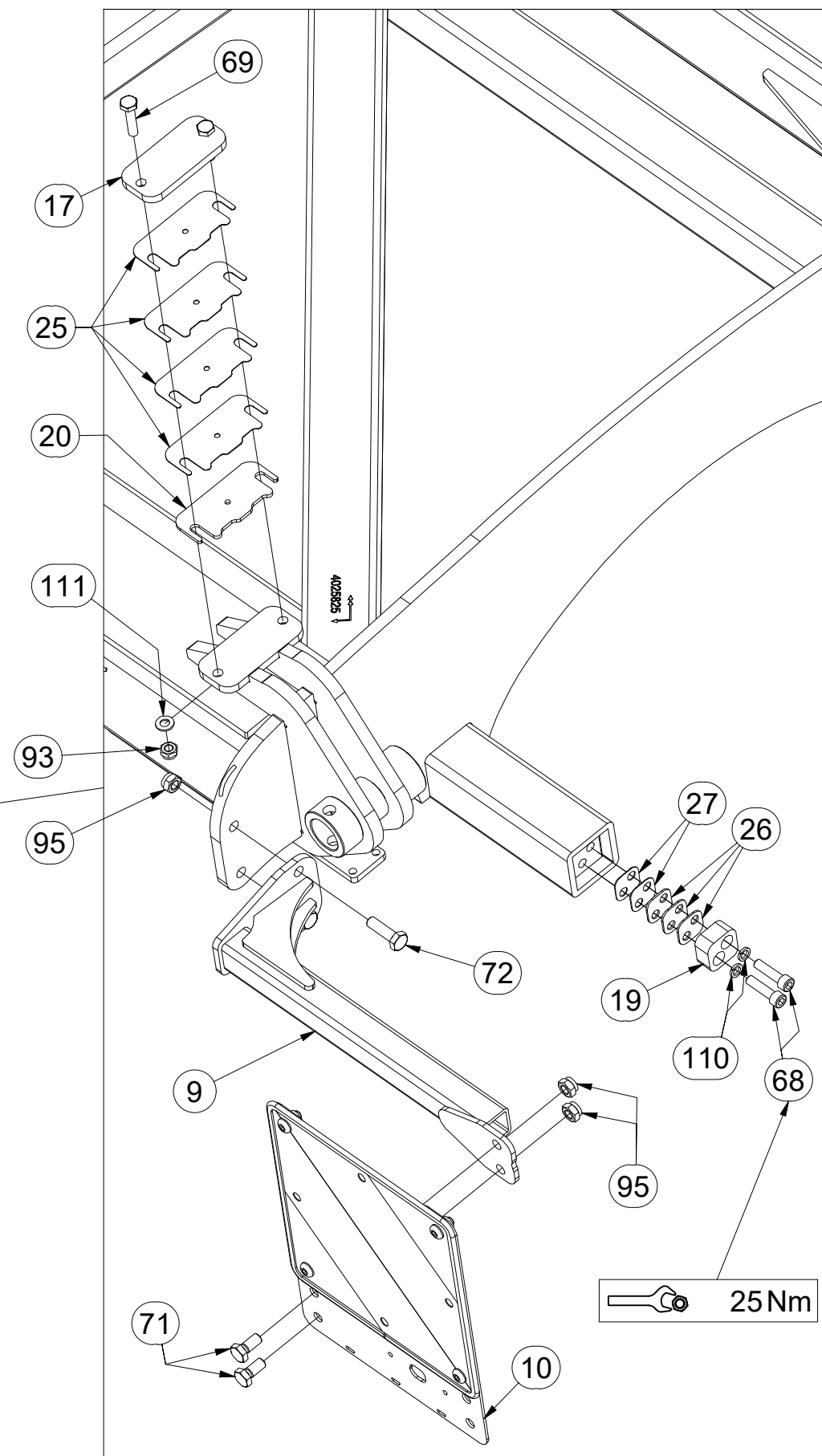
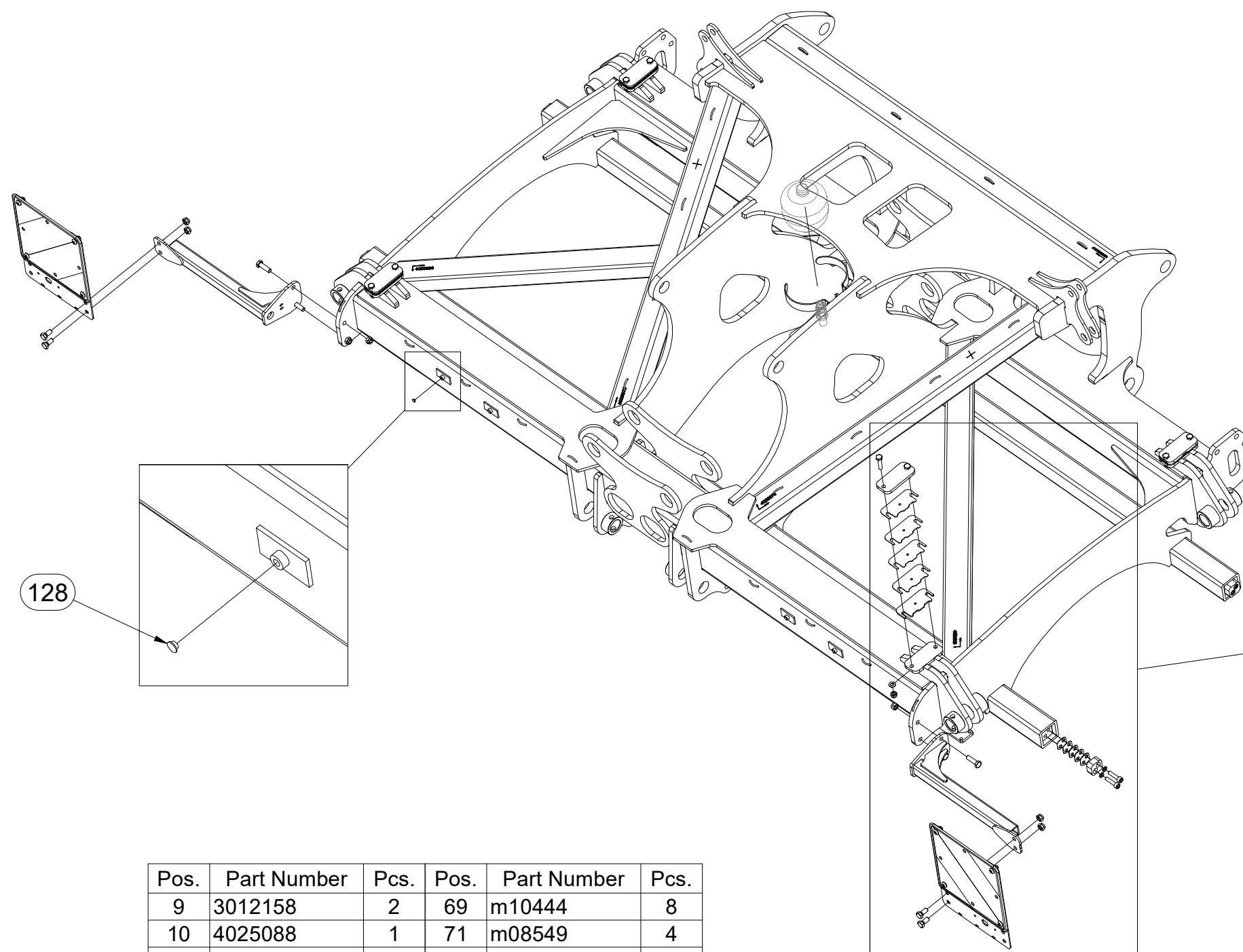

Pos.	Part Number	Pcs.	Pos.	Part Number	Pcs.
9	3012158	2	69	m10444	8
10	4025088	1	71	m08549	4
17	9003113	4	72	m03926	4
19	4017089	4	93	m03775	16
20	4010440	4	95	m04301	36
25	4010030	16	110	m01208	8
26	4017090	12	111	m01209	8
27	4017091	8	128	m12142	4
68	m14009	8			

Ⓒ ZÁKLAD STROJE

Ⓓ UNTERBAU DER MASCHINE

Ⓕ BÂTI DE LA MACHINE

Ⓖ FOOTING OF THE MACHINE

Ⓡ ОСНОВАНИЕ МАШИНЫ

Ⓢ PODSTAWA MASZYNY



**VZ00016796**

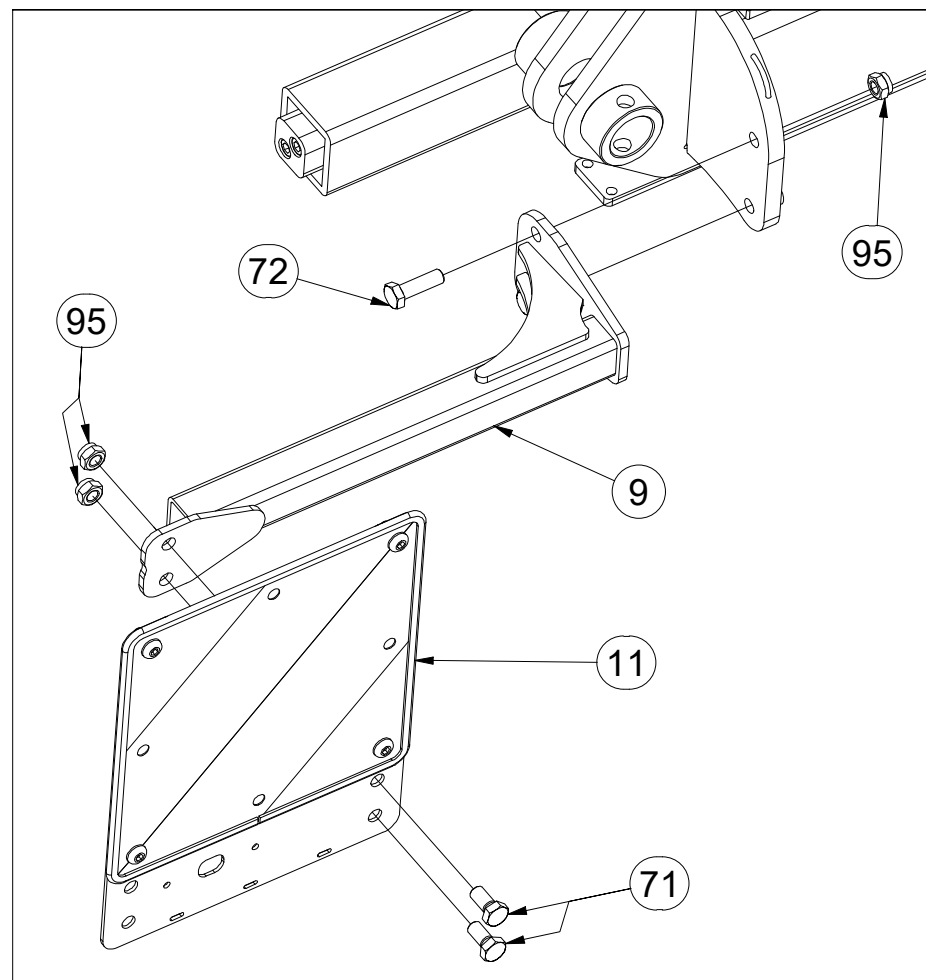
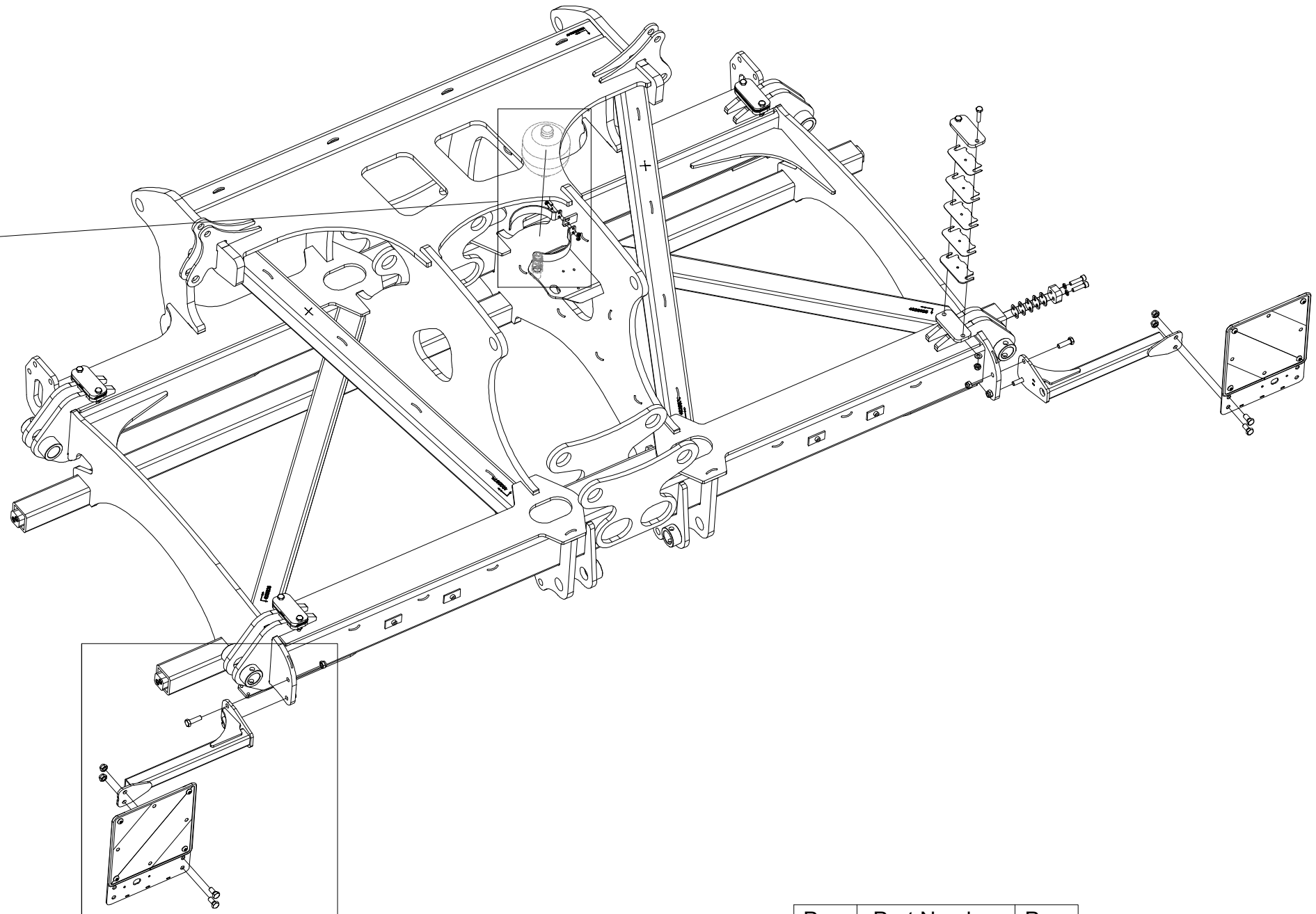
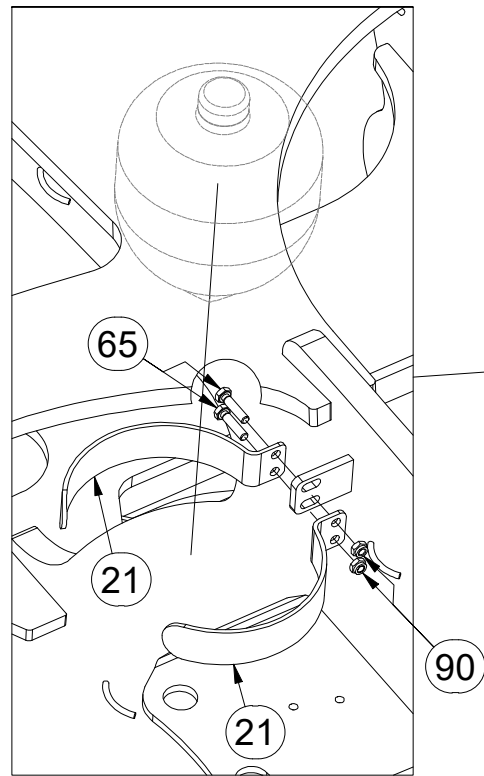

Pos.	Part Number	Pcs.
9	3012158	2
11	4025089	1
21	4015860	2
65	m01075	2
71	m08549	4
72	m03926	4
90	m05560	2
95	m04301	36

Ⓒ ZÁKLAD STROJE

Ⓓ UNTERBAU DER MASCHINE

Ⓕ BÂTI DE LA MACHINE

Ⓖ FOOTING OF THE MACHINE

Ⓡ ОСНОВАНИЕ МАШИНЫ

Ⓟ PODSTAWA MASZYNY



**VZ00016796**

Pos.	Part Number	Pcs.
18	4025934	4
53	4007816	4
75	m13033	4
80	m13859	2
95	m04301	36
99	m21660	2
127	m15002	4

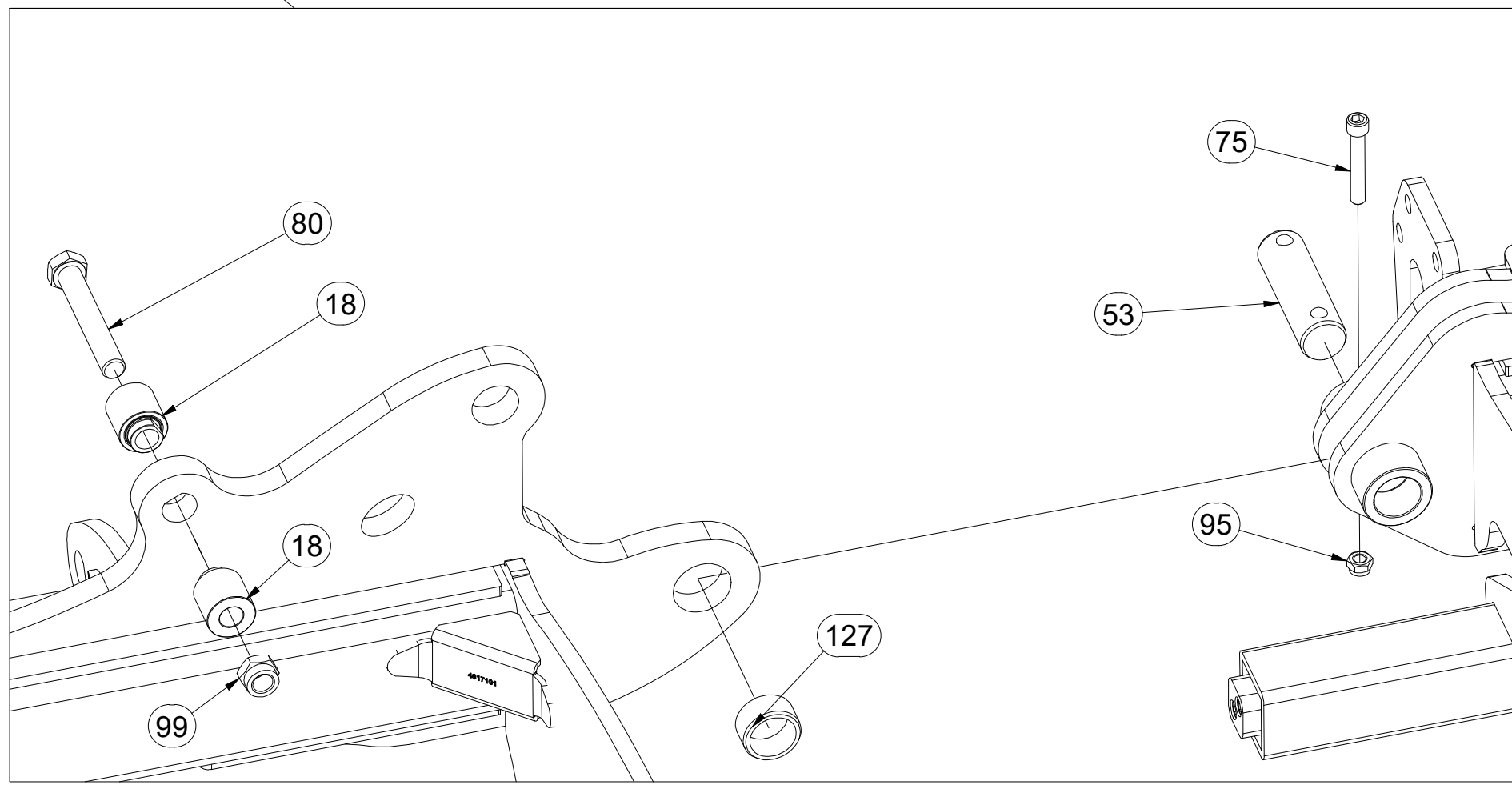
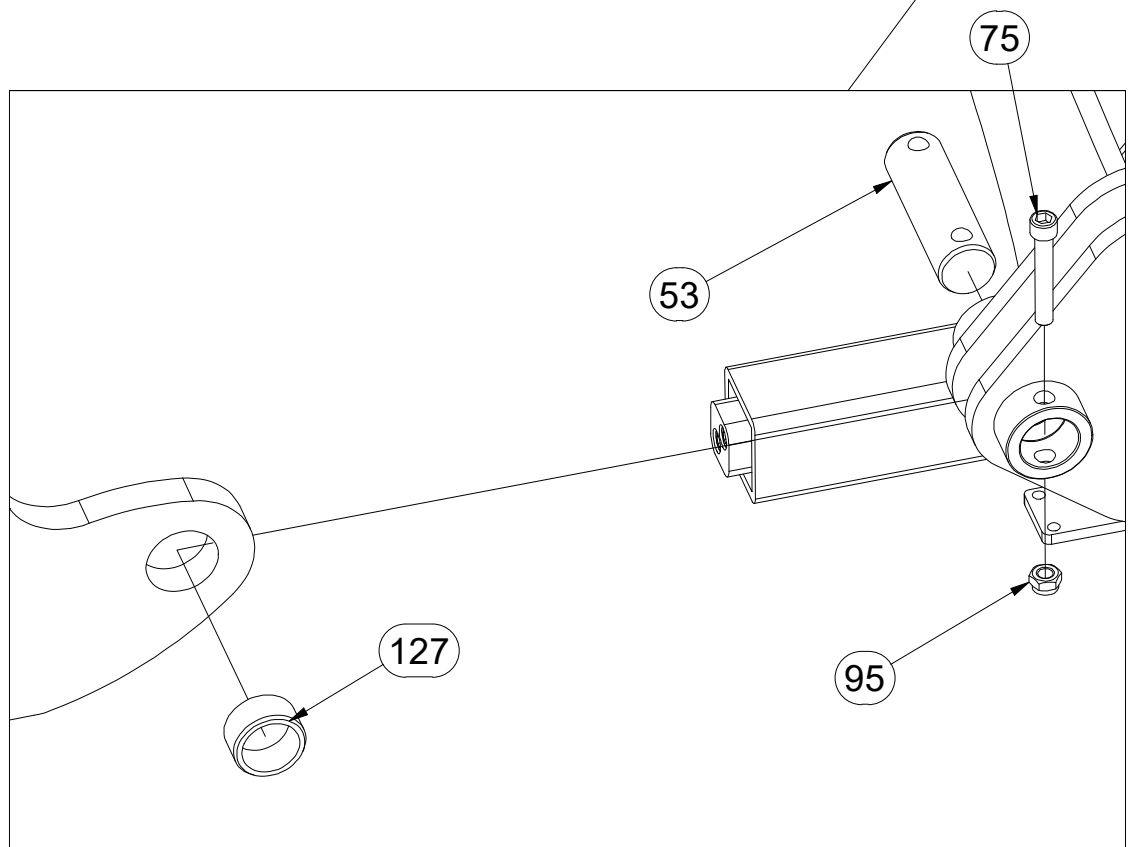
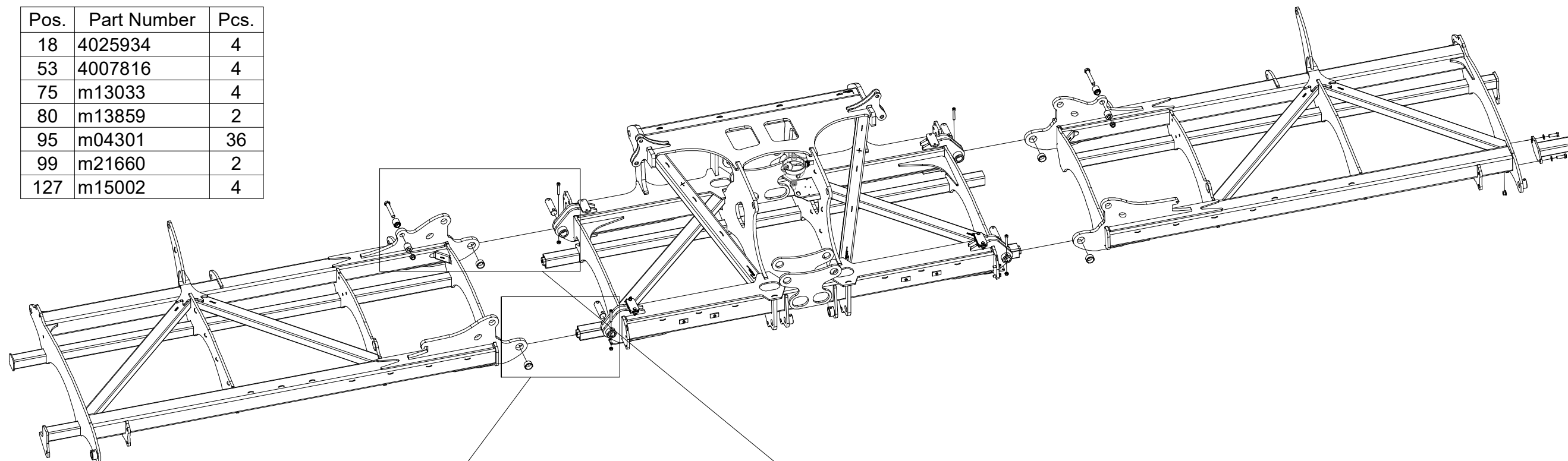

Ⓒ ZÁKLAD STROJE

Ⓓ UNTERBAU DER MASCHINE

Ⓕ BÂTI DE LA MACHINE

Ⓖ FOOTING OF THE MACHINE

Ⓡ ОСНОВАНИЕ МАШИНЫ

Ⓢ PODSTAWA MASZYNY



**VZ00016796**

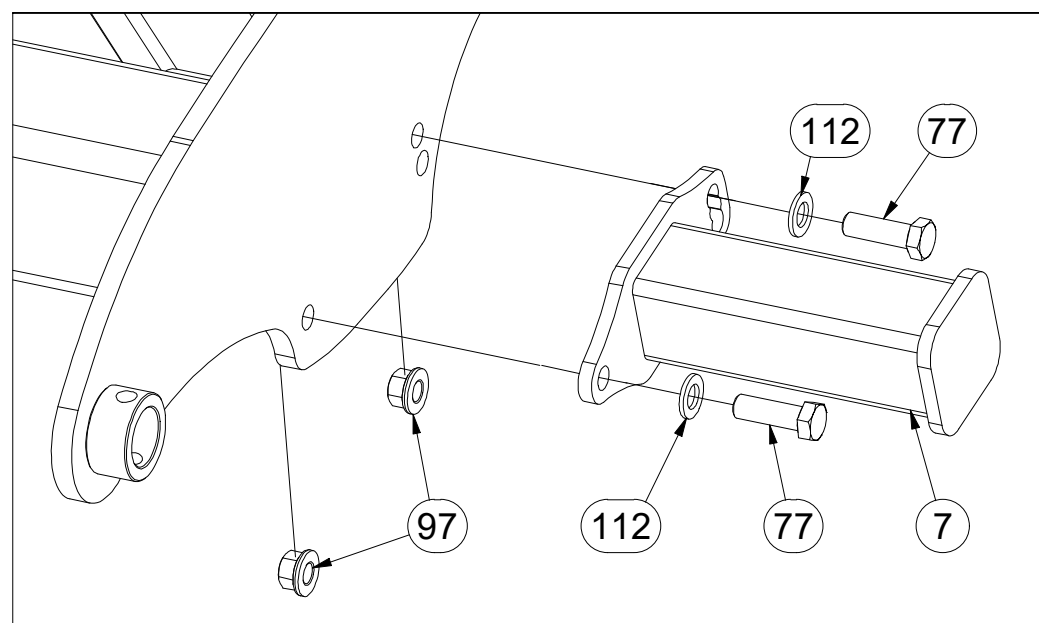
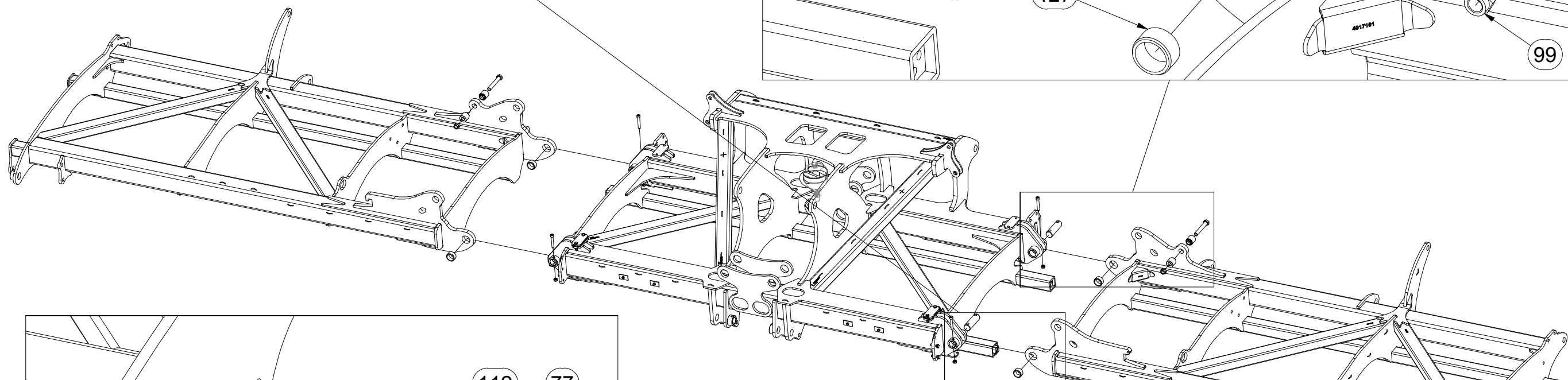
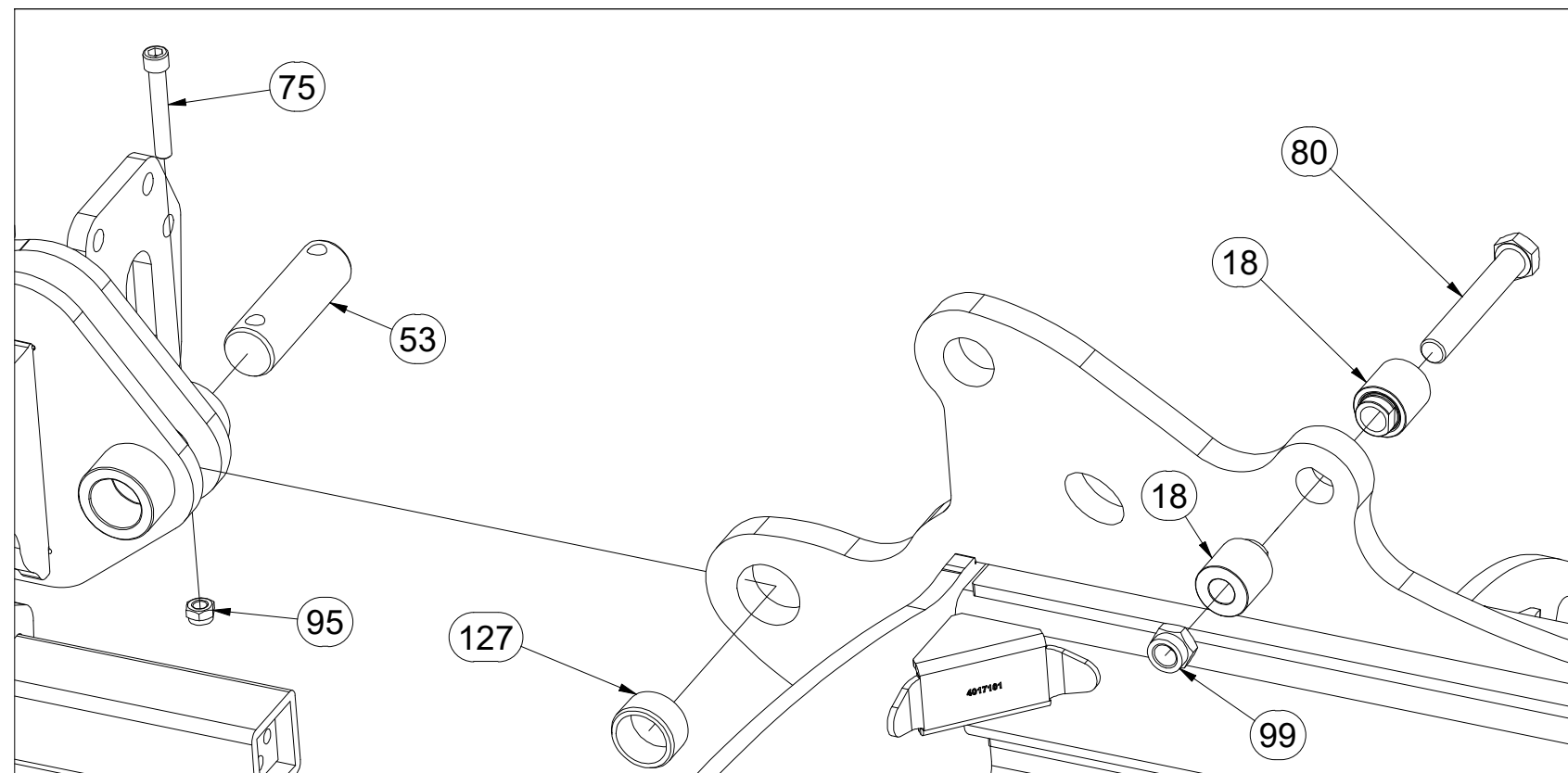
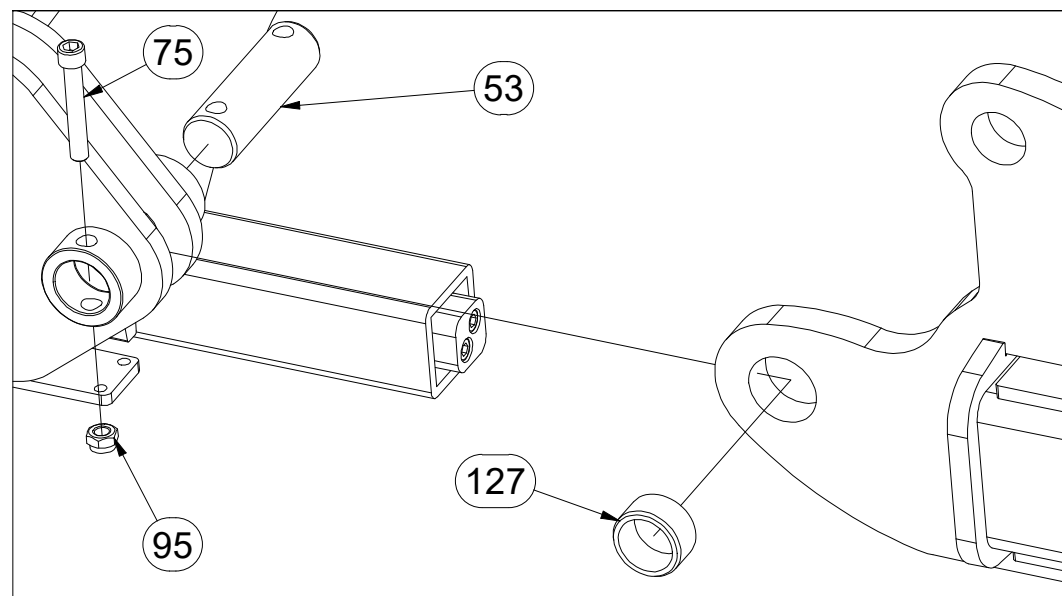

Pos.	Part Number	Pcs.	Pos.	Part Number	Pcs.
7	3007071	1	95	m04301	36
18	4025934	4	97	m15730	2
53	4007816	4	99	m21660	2
75	m13033	4	112	m01219	2
77	m04355	2	127	m15002	4
80	m13859	2			

☉ ZÁKLAD STROJE

☐ UNTERBAU DER MASCHINE

☉ BÂTI DE LA MACHINE

**VZ00016796**

☉ FOOTING OF THE MACHINE

☉ ОСНОВАНИЕ МАШИНЫ

☉ PODSTAWA MASZyny

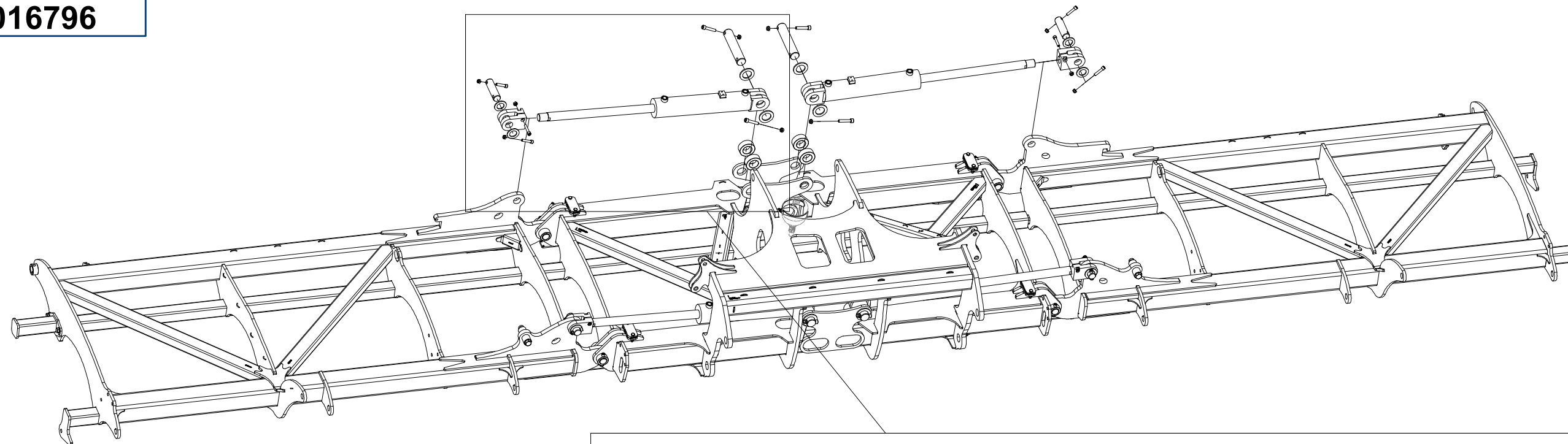

Pos.	Part Number	Pcs.
16	4025723	4
44	m21533	4
45	m15149	4
51	4012990	8
73	m14008	24
74	m14867	4
76	m13957	8
94	m10439	4
95	m04301	36
96	m04990	8
118	4013139	24
120	4015687	8

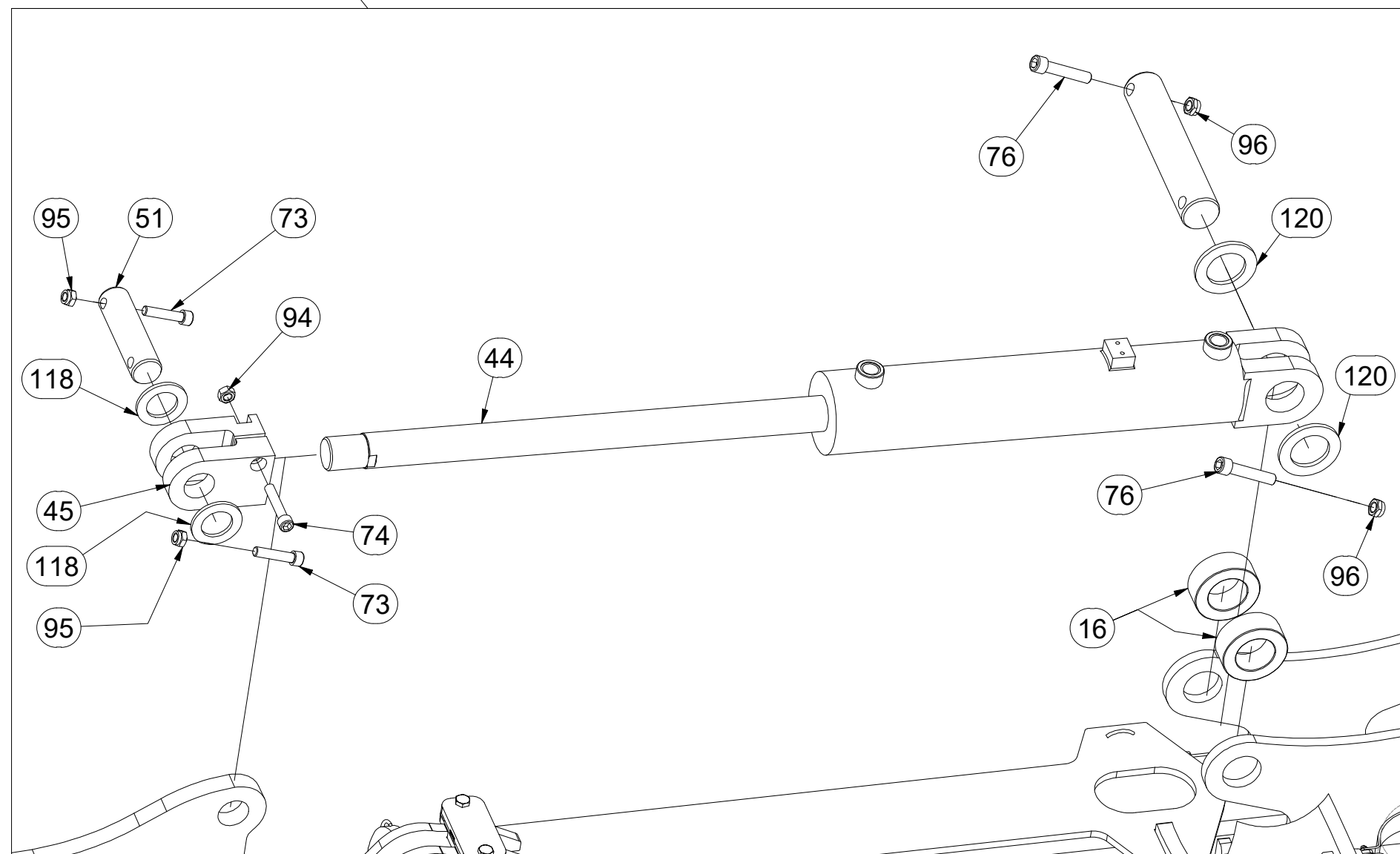



Ⓒ ZÁKLAD STROJE

Ⓓ UNTERBAU DER MASCHINE

Ⓕ BÂTI DE LA MACHINE

Ⓖ FOOTING OF THE MACHINE

Ⓡ ОСНОВАНИЕ МАШИНЫ

Ⓢ PODSTAWA MASZINY



**VZ00016796**

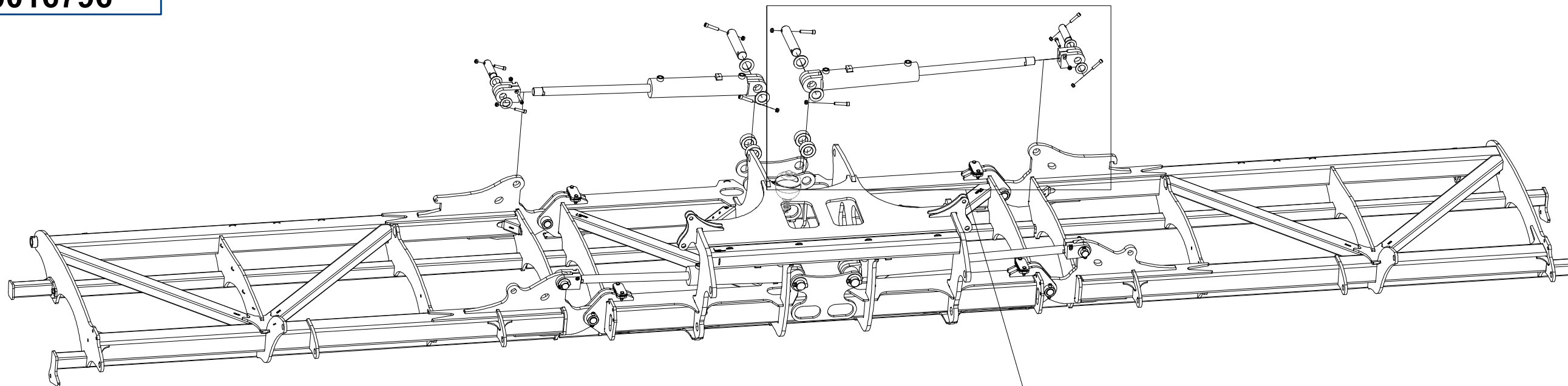

Pos.	Part Number	Pcs.
16	4025723	4
44	m21533	4
45	m15149	4
50	4025722	4
51	4012990	8
73	m14008	24
74	m14867	4
76	m13957	8
94	m10439	4
95	m04301	36
96	m04990	8
118	4013139	24
120	4015687	8

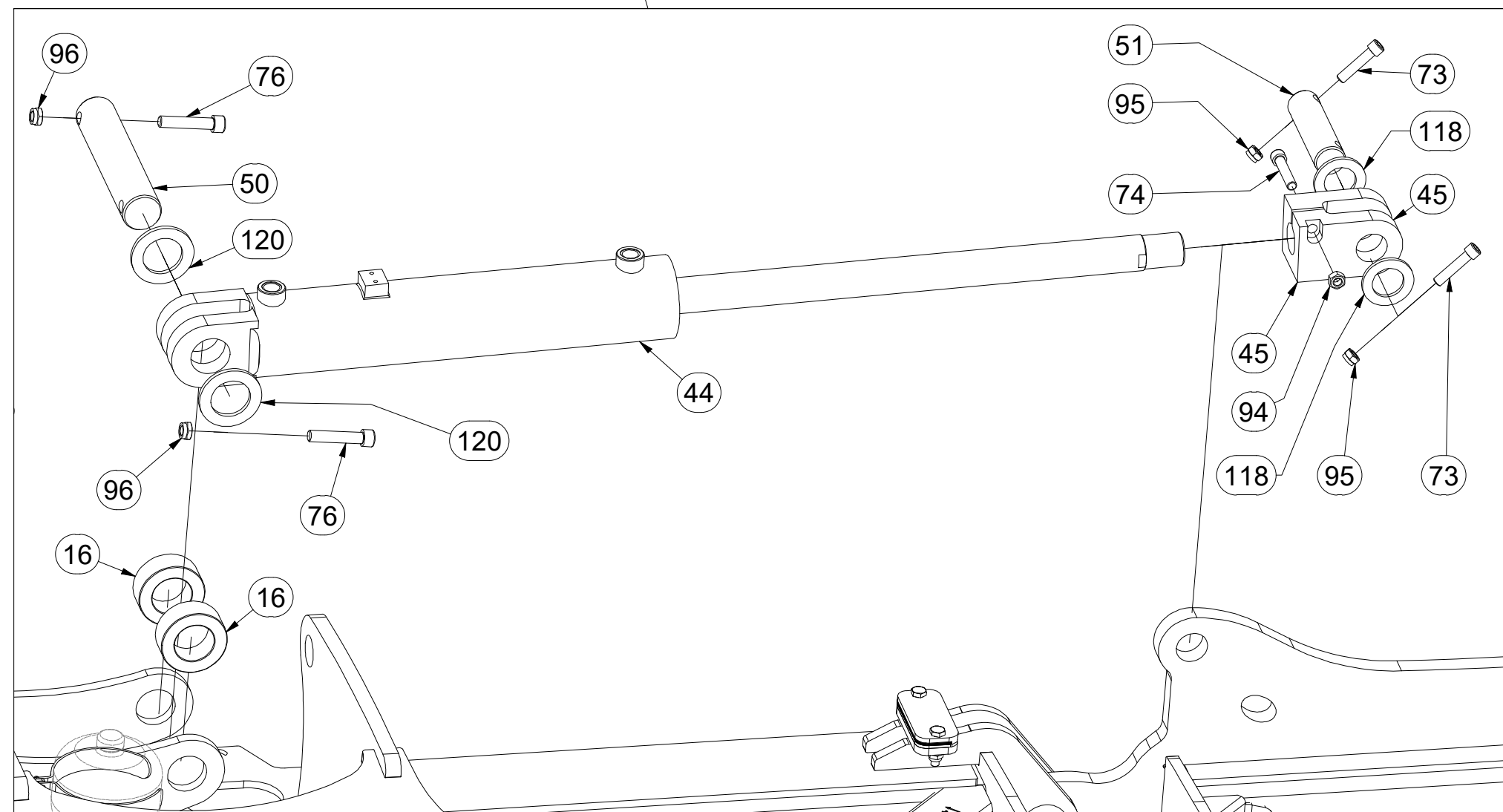

Ⓒ ZÁKLAD STROJE

Ⓓ UNTERBAU DER MASCHINE

Ⓕ BÂTI DE LA MACHINE

**VZ00016796**

Ⓖ FOOTING OF THE MACHINE

Ⓡ ОСНОВАНИЕ МАШИНЫ

Ⓟ PODSTAWA MASZYNY

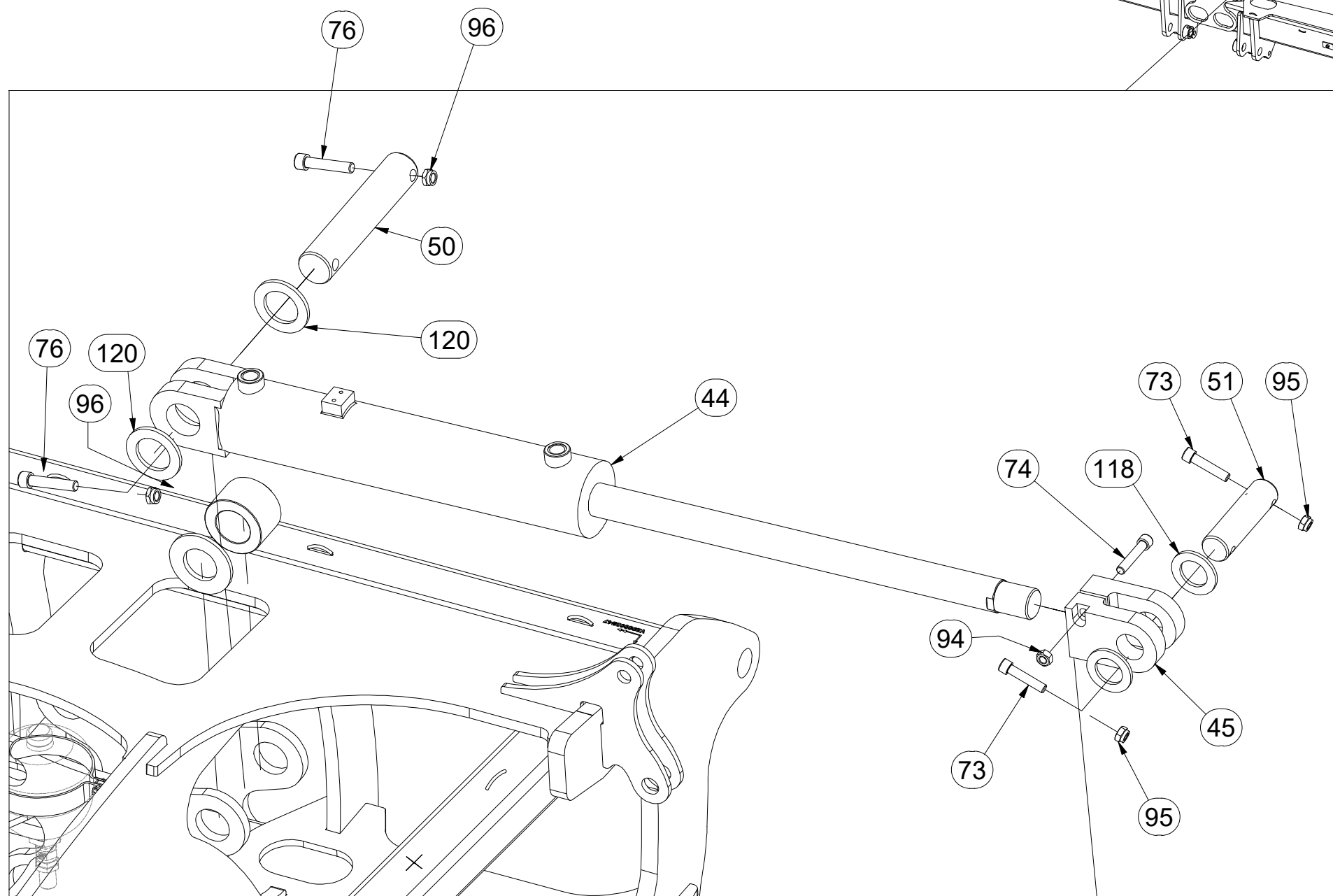
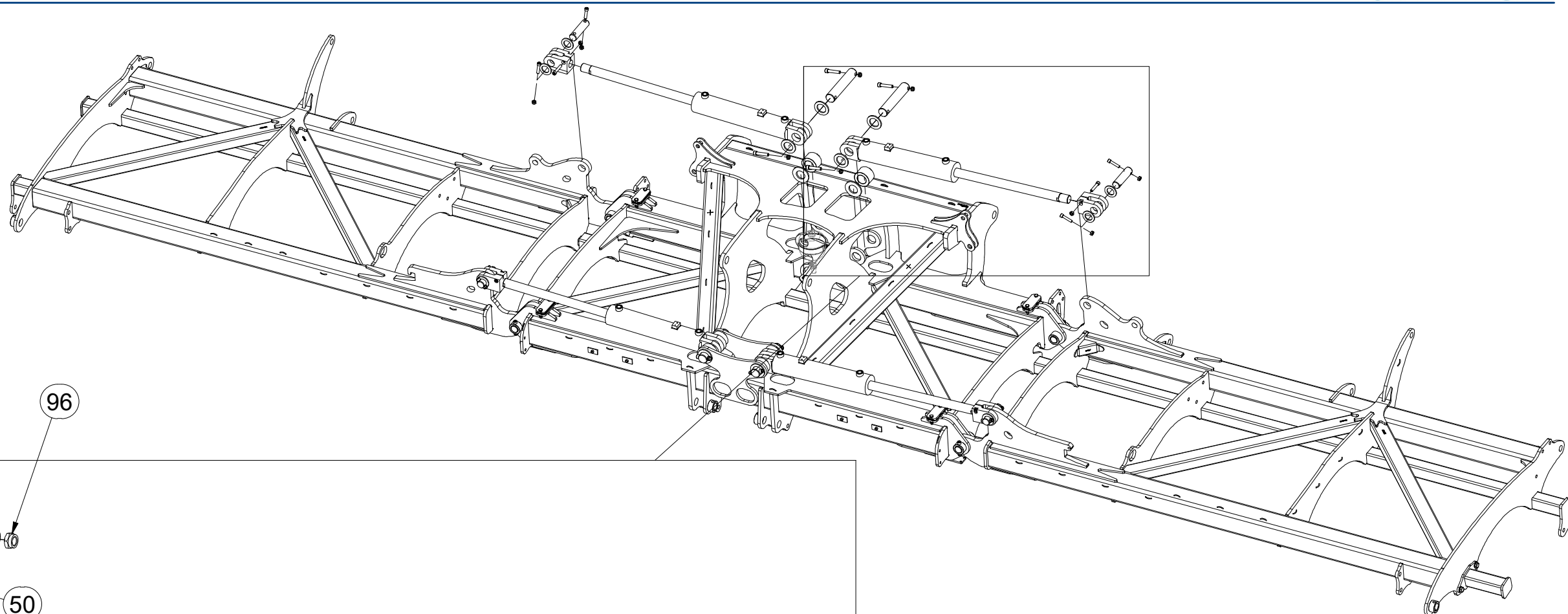

Pos.	Part Number	Pcs.
44	m21533	4
45	m15149	4
50	4025722	4
51	4012990	8
73	m14008	24
74	m14867	4
76	m13957	8
94	m10439	4
95	m04301	36
96	m04990	8
118	4013139	24
120	4015687	8

Ⓒ ZÁKLAD STROJE

Ⓓ UNTERBAU DER MASCHINE

Ⓕ BÂTI DE LA MACHINE

**VZ00016796**

Ⓖ FOOTING OF THE MACHINE

Ⓡ ОСНОВАНИЕ МАШИНЫ

Ⓟ PODSTAWA MASZYNY

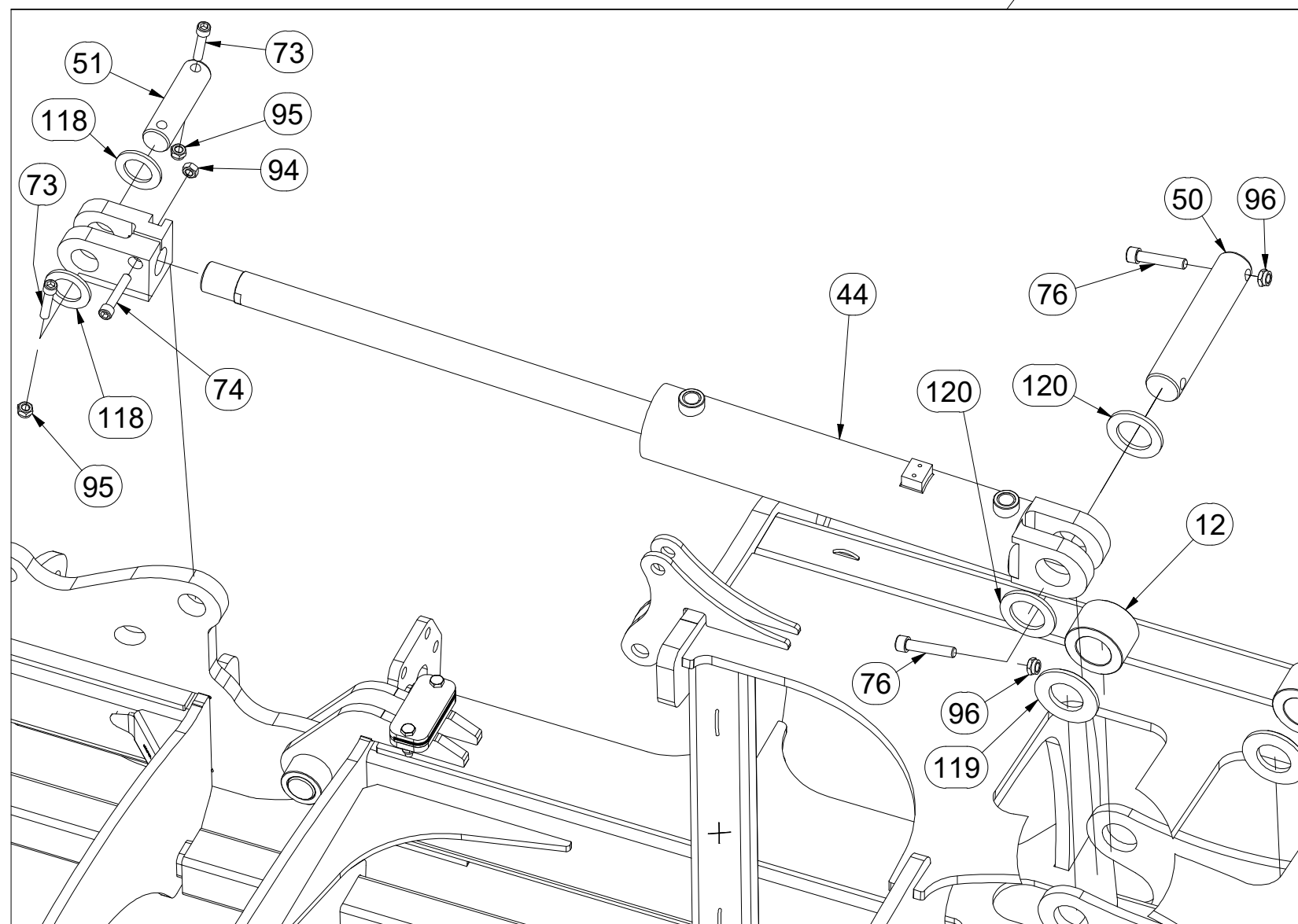
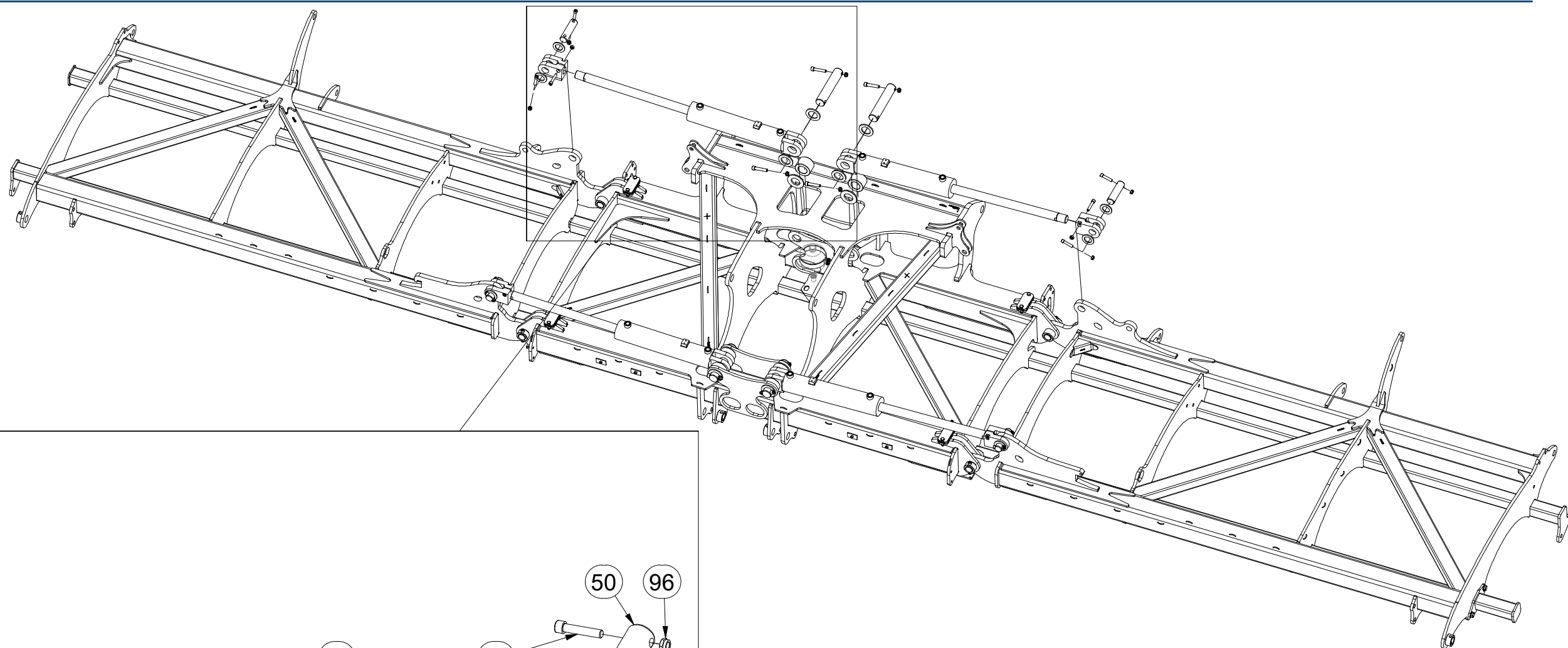

Pos.	Part Number	Pcs.
12	4025774	2
44	m21533	4
50	4025722	4
51	4012990	8
73	m14008	24
74	m14867	4
76	m13957	8
94	m10439	4
95	m04301	36
96	m04990	8
118	4013139	24
119	m04938	2
120	4015687	8

☉ ZÁKLAD STROJE

Ⓧ UNTERBAU DER MASCHINE

Ⓧ BÂTI DE LA MACHINE

Ⓧ FOOTING OF THE MACHINE

Ⓧ ОСНОВАНИЕ МАШИНЫ

Ⓧ PODSTAWA MASZYNY



**VZ00016796**

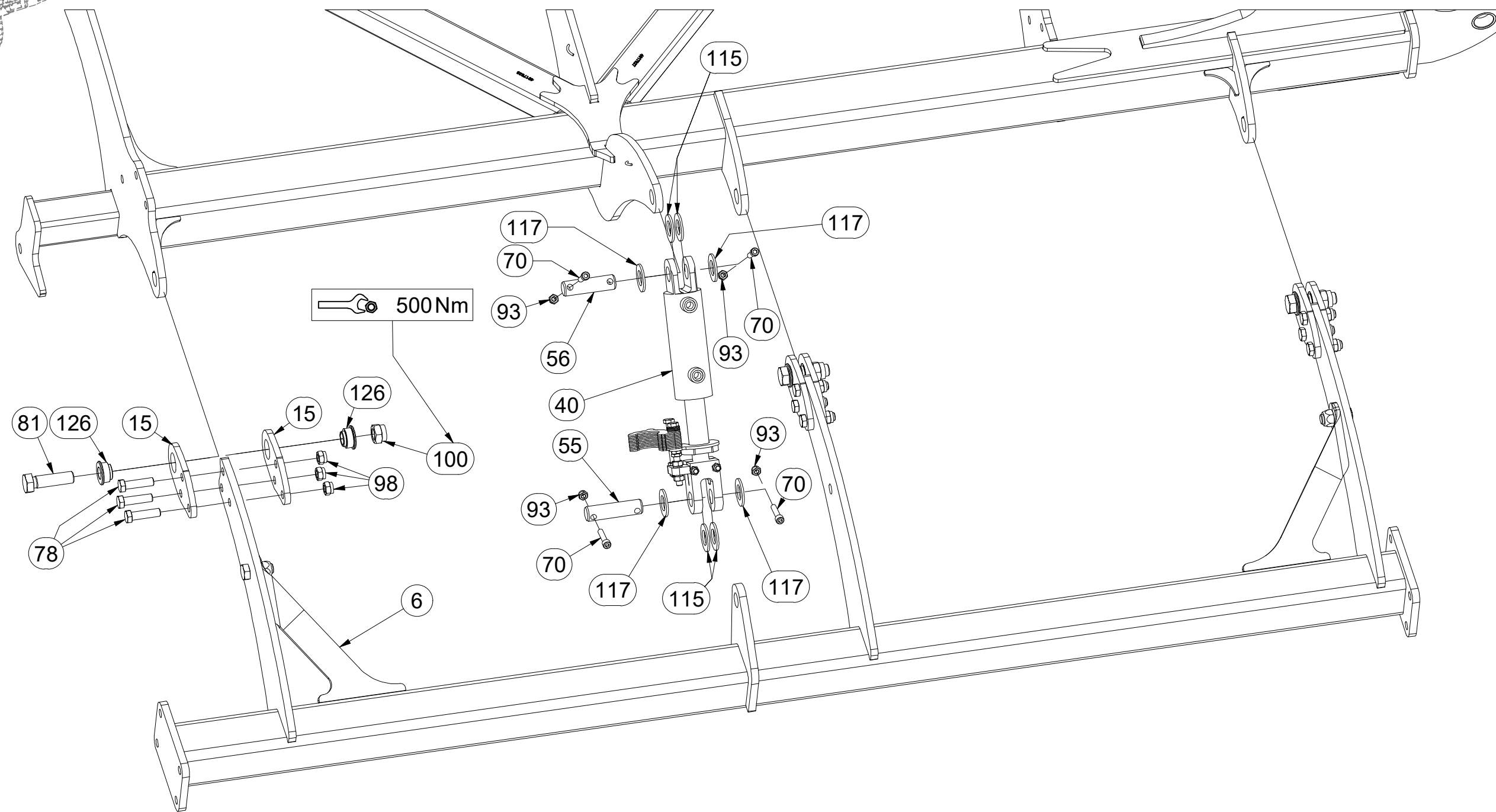
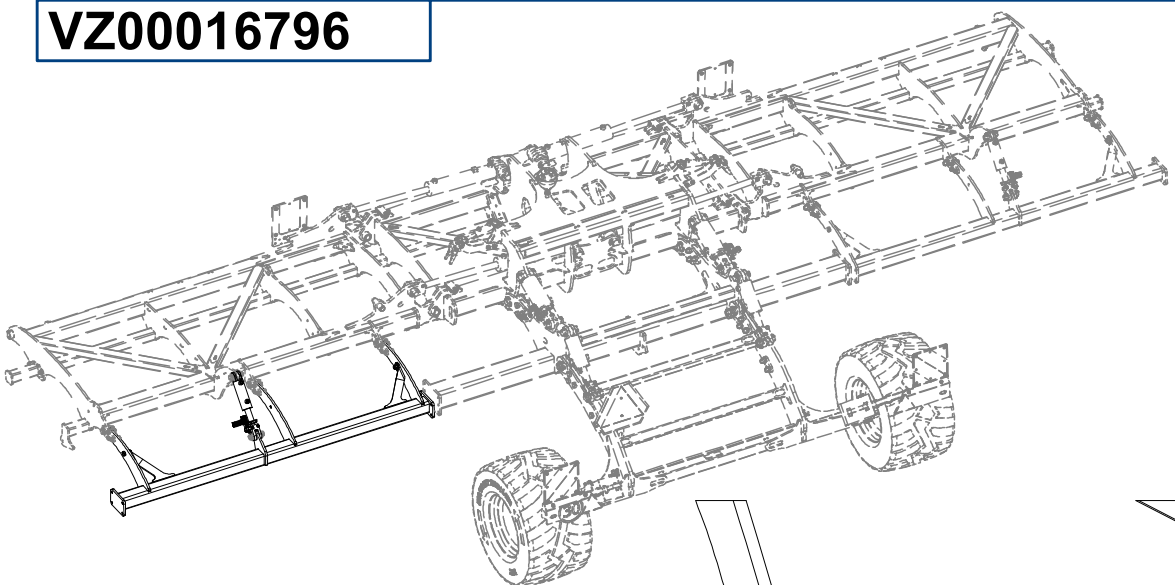

Pos.	Part Number	Pcs.
6	3008714	1
15	4014704	12
40	4015781	2
55	4007639	2
56	4007584	2
70	m14143	8
78	m14482	18
81	m08532	6
93	m03775	16
98	m03683	24
100	m07147	12
115	m02866	8
117	m14029	8
126	m14506	12

☉ ZÁKLAD STROJE

Ⓧ UNTERBAU DER MASCHINE

Ⓧ BÂTI DE LA MACHINE

Ⓧ FOOTING OF THE MACHINE

Ⓧ ОСНОВАНИЕ МАШИНЫ

Ⓧ PODSTAWA MASZYNY



**VZ00016796**

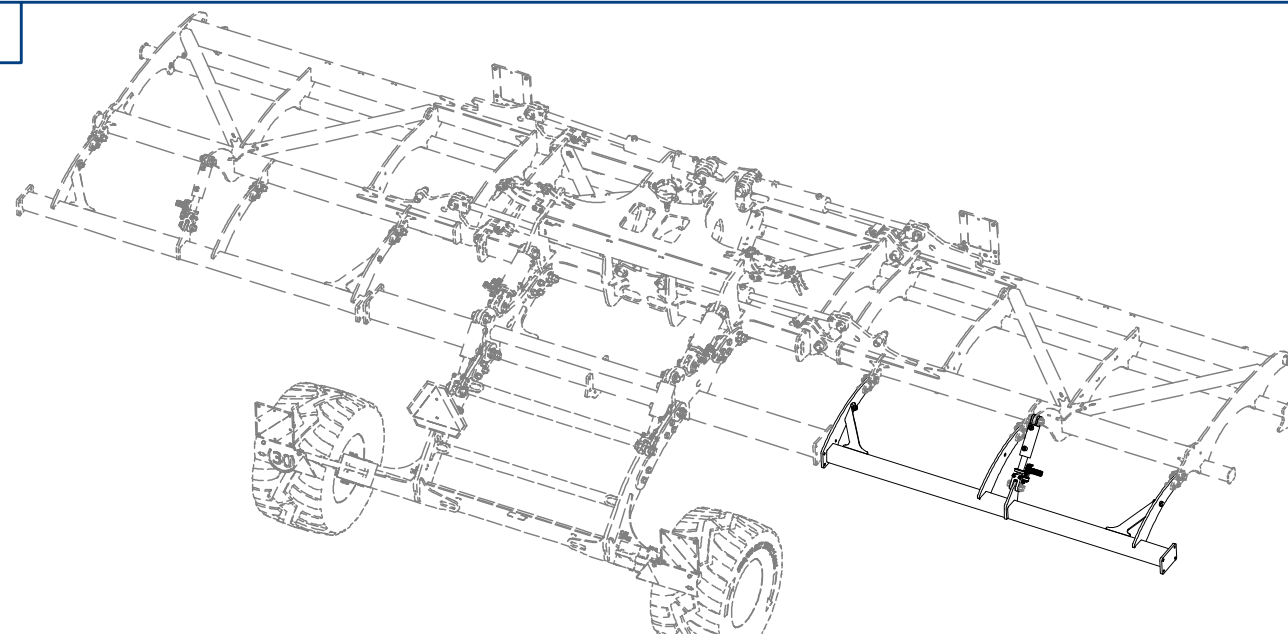

Pos.	Part Number	Pcs.	Pos.	Part Number	Pcs.
5	3008715	1	81	m08532	6
15	4014704	12	93	m03775	16
40	4015781	2	98	m03683	24
55	4007639	2	100	m07147	12
56	4007584	2	115	m02866	8
70	m14143	8	117	m14029	8
78	m14482	18	126	m14506	12

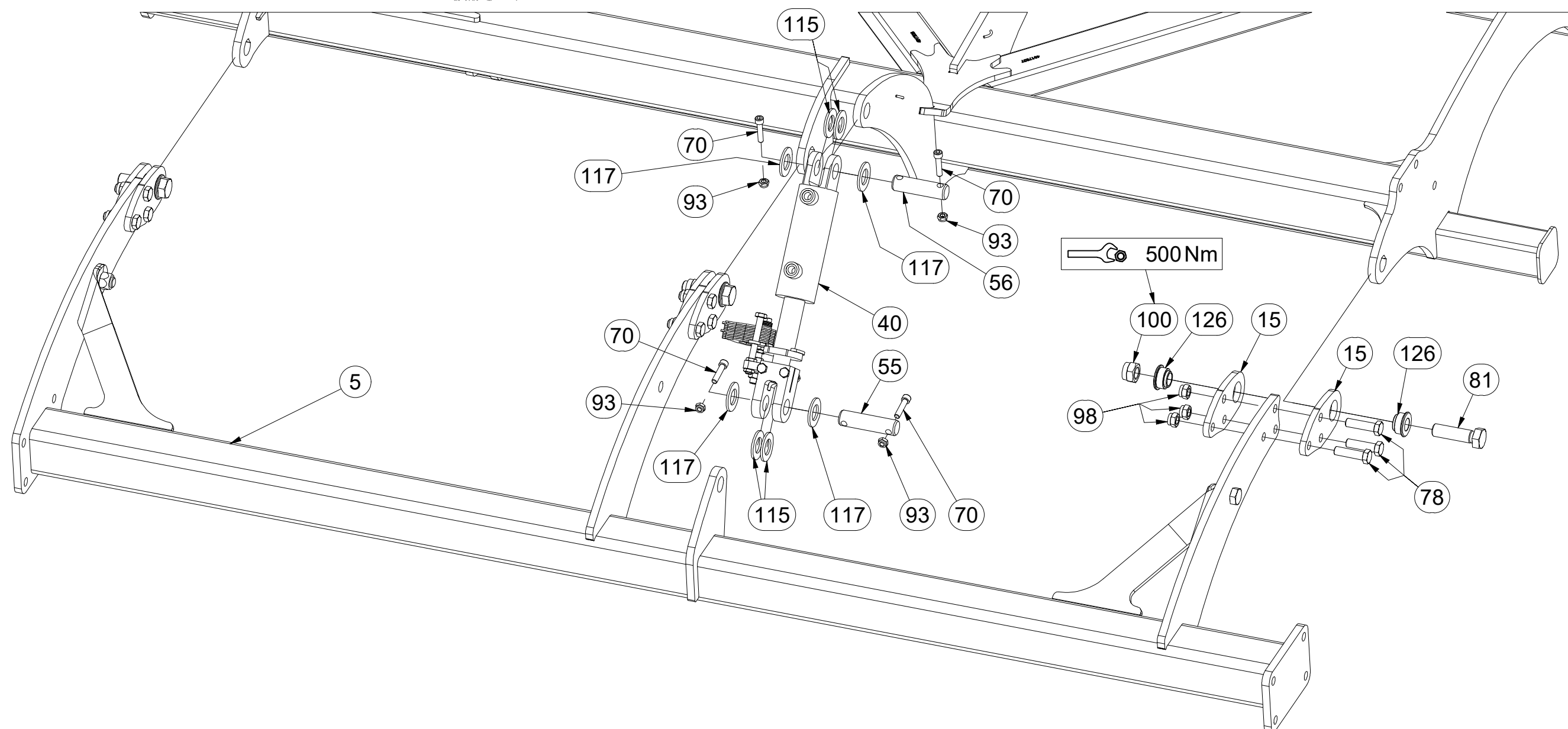

☉ ZÁKLAD STROJE

☉ UNTERBAU DER MASCHINE

☉ BÂTI DE LA MACHINE

**VZ00016796**

☉ FOOTING OF THE MACHINE

☉ ОСНОВАНИЕ МАШИНЫ

☉ PODSTAWA MASZYNY

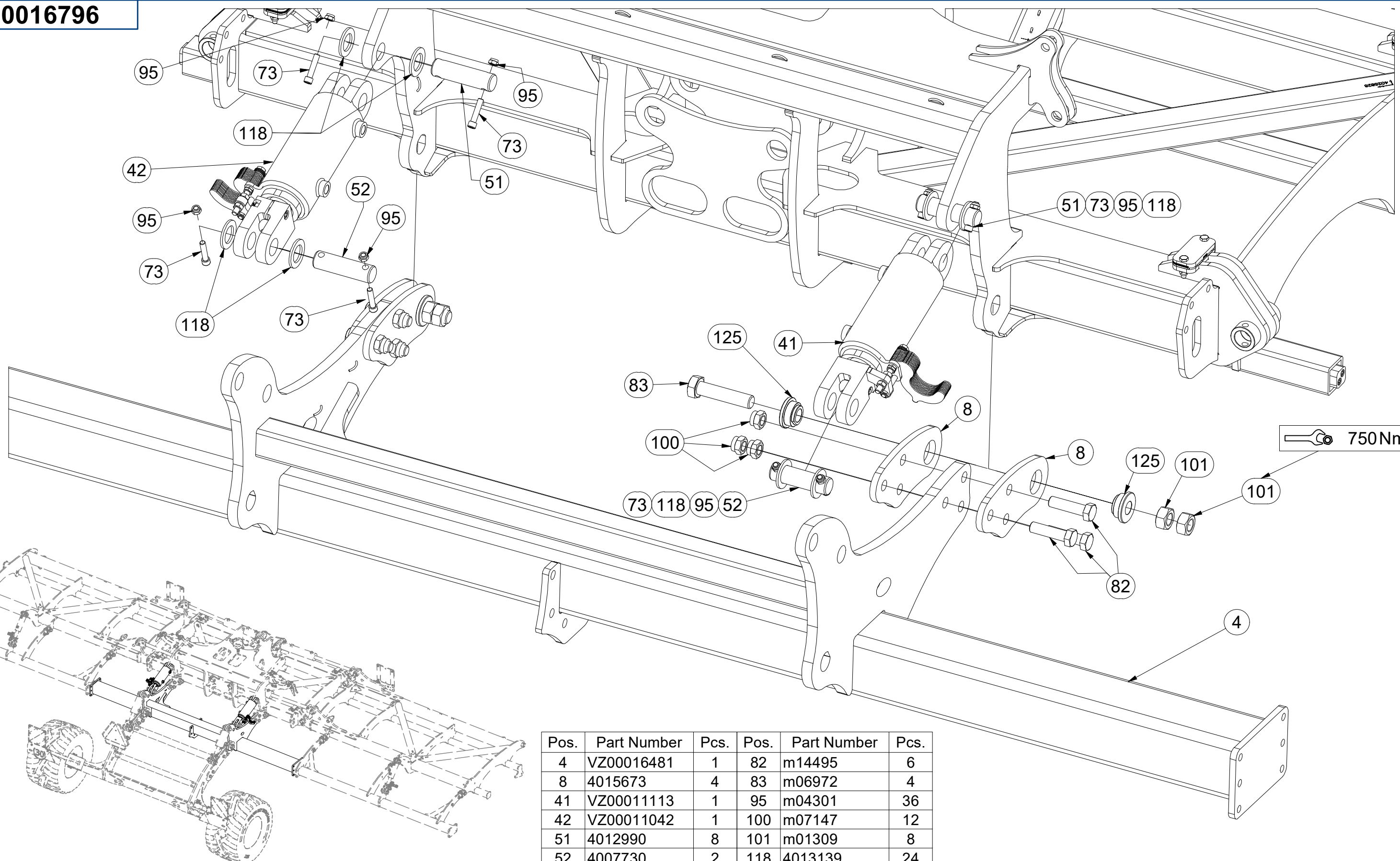

Pos.	Part Number	Pcs.	Pos.	Part Number	Pcs.
4	VZ00016481	1	82	m14495	6
8	4015673	4	83	m06972	4
41	VZ00011113	1	95	m04301	36
42	VZ00011042	1	100	m07147	12
51	4012990	8	101	m01309	8
52	4007730	2	118	4013139	24
73	m14008	24	125	m14505	8

Ⓒ ZÁKLAD STROJE

Ⓓ UNTERBAU DER MASCHINE

Ⓕ BÂTI DE LA MACHINE

Ⓖ FOOTING OF THE MACHINE

Ⓡ ОСНОВАНИЕ МАШИНЫ

Ⓢ PODSTAWA MASZINY



**VZ00016796**

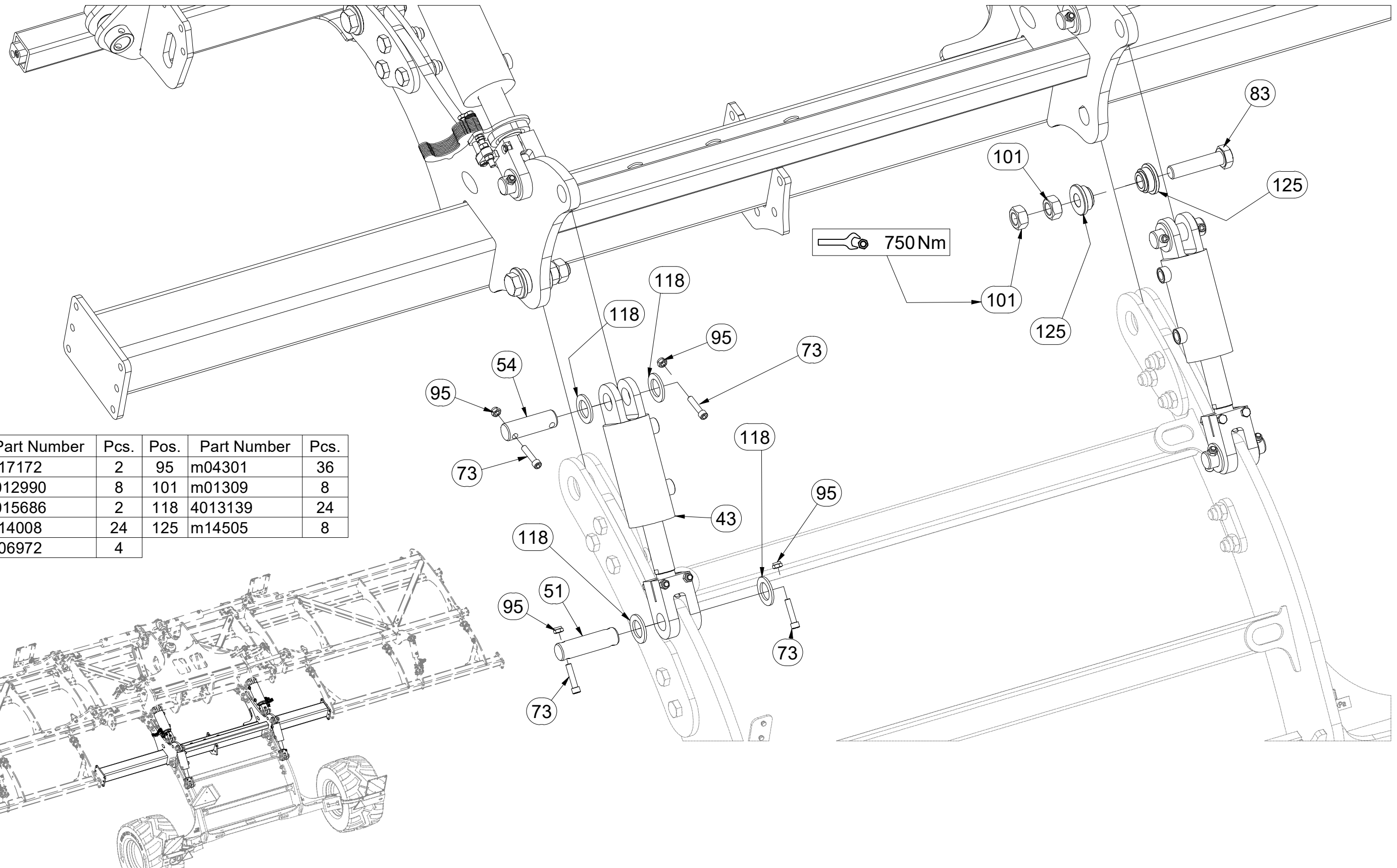

Pos.	Part Number	Pcs.	Pos.	Part Number	Pcs.
43	m17172	2	95	m04301	36
51	4012990	8	101	m01309	8
54	4015686	2	118	4013139	24
73	m14008	24	125	m14505	8
83	m06972	4			

Ⓒ ZÁKLAD STROJE

Ⓓ UNTERBAU DER MASCHINE

Ⓕ BÂTI DE LA MACHINE

**VZ00016796**

Ⓖ FOOTING OF THE MACHINE

Ⓡ ОСНОВАНИЕ МАШИНЫ

Ⓟ PODSTAWA MASZYNY

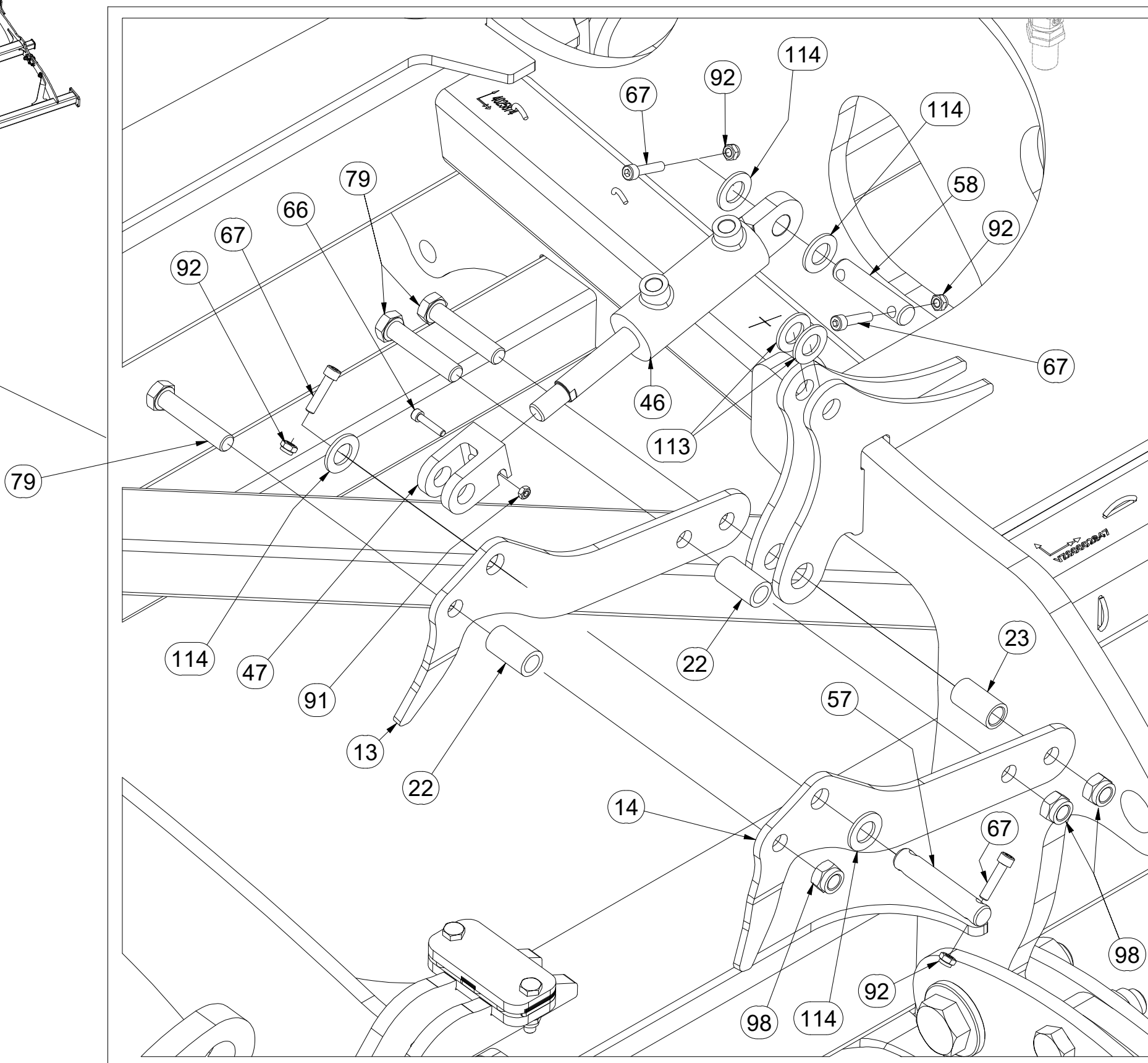
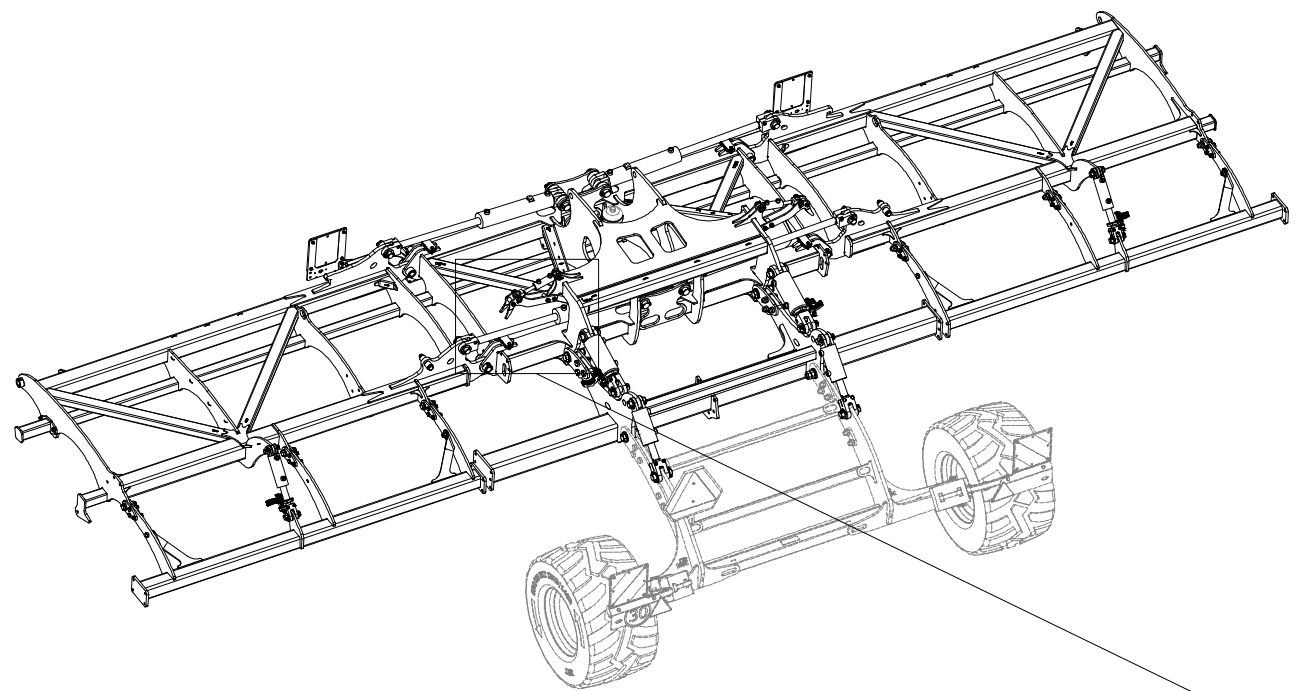

Pos.	Part Number	Pcs.	Pos.	Part Number	Pcs.
13	VZ00008785	2	67	m09464	8
14	VZ00016802	2	79	m03767	6
18	4025934	4	80	m13859	2
22	4025932	4	91	m01295	2
23	4025773	2	92	m04503	8
46	m20711	2	98	m03683	24
47	m20748	2	99	m21660	2
57	4021656	2	113	m03768	4
58	4013486	2	114	m14030	8
66	m06101	2			



CZ TERČ PŘEDNÍ LEVÝ  
 D SCHILD, VORDERES, LINKES  
 F CIBLE AVANT GAUCHE

GB LEFT FRONT DISC  
 RU ЩИТОК ПЕРЕДНИЙ ЛЕВЫЙ  
 PL TARCZA PRZEDNIA LEWA



4025088

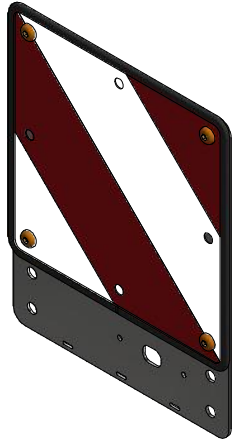
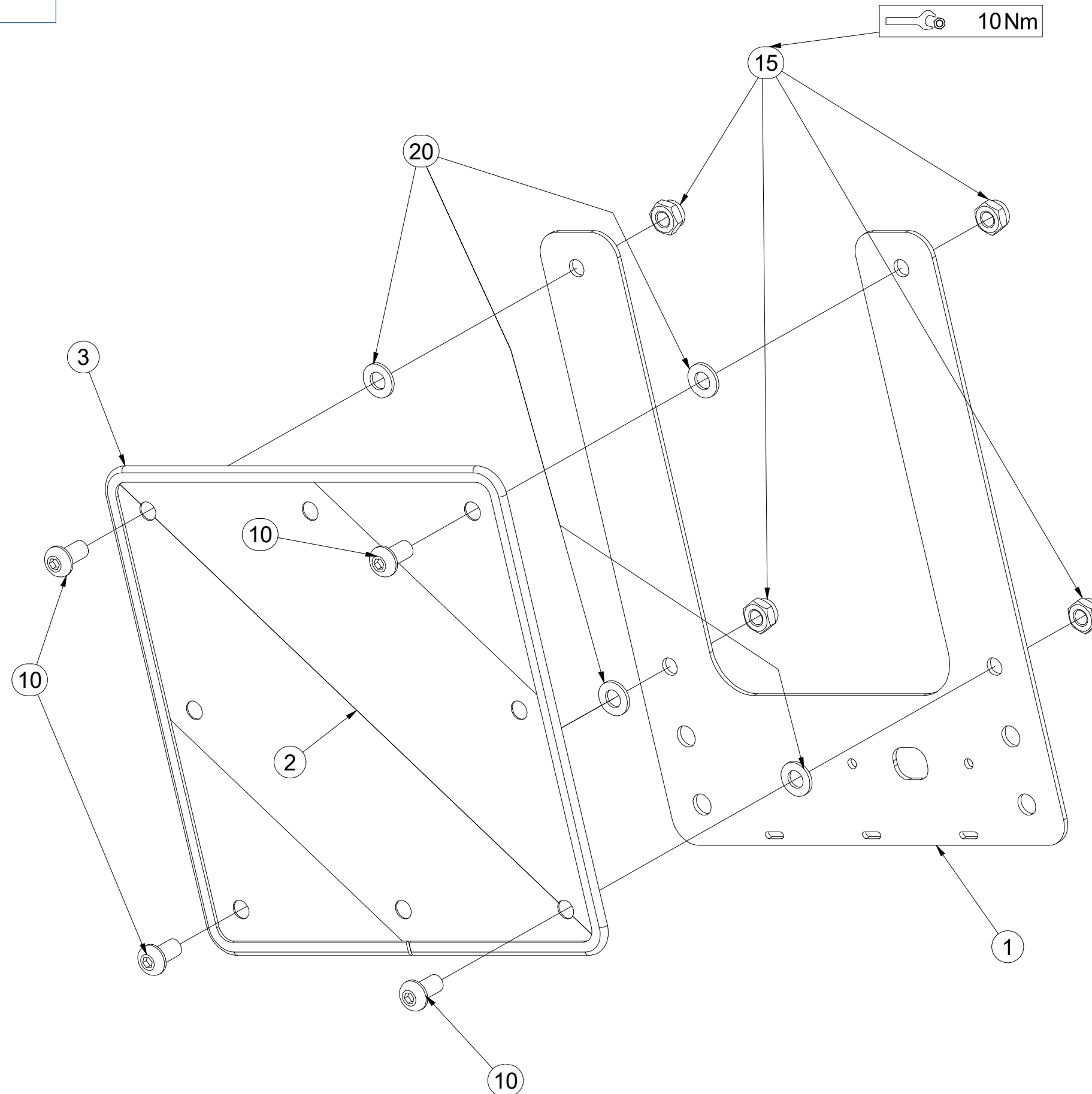

Pos.	Part Number	Pcs.
1	4025090	1
2	m18855	1
3	9005707	1
10	m16637	4
15	m03775	4
20	m01209	4

ⒸZ TERČ PŘEDNÍ PRAVÝ

Ⓓ SCHILD, VORDERES, RECHTES

Ⓕ CIBLE AVANT DROITE

ⒼB RIGHT FRONT DISC

ⒶU ЩИТОК ПЕРЕДНИЙ ПРАВЫЙ

ⒶL TARCZA PRZEDNIA PRAWA



**4025089**

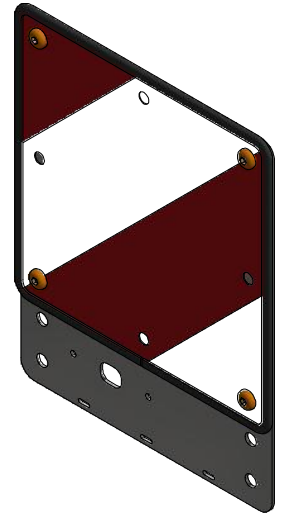
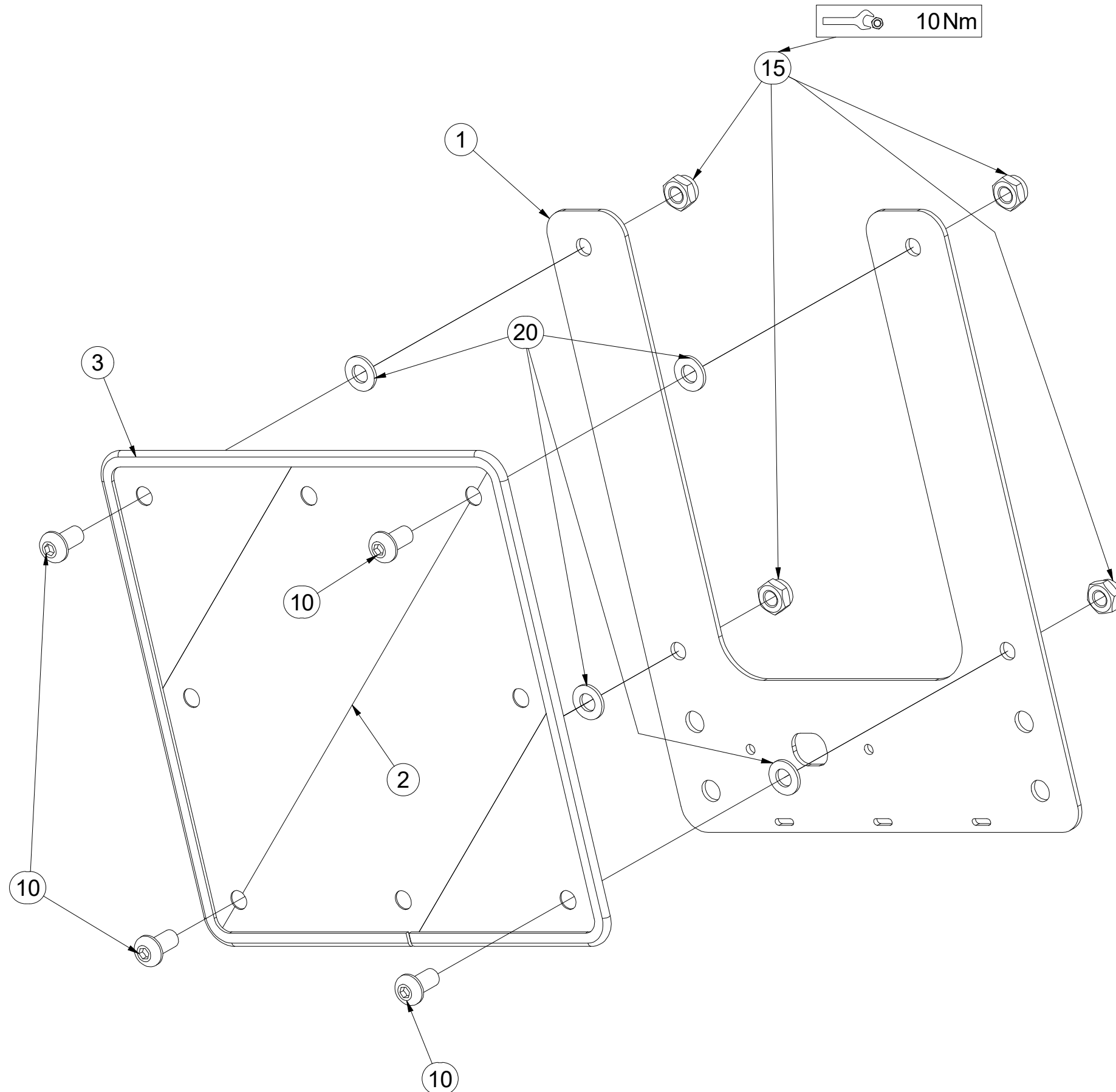

Pos.	Part Number	Pcs.
1	4025090	1
2	m18855	1
3	9005707	1
10	m16637	4
15	m03775	4
20	m01209	4

- Ⓒ KOPÍROVACÍ KOLA
- Ⓓ KOPIERRÄDER
- Ⓕ COPIAGE DU TERRAIN

- Ⓖ TRACING WHEELS
- Ⓔ КОПИРУЮЩЕЕ КОЛЕСА
- Ⓗ КОЛА КОПИУЈАЌЕ



**3011554**

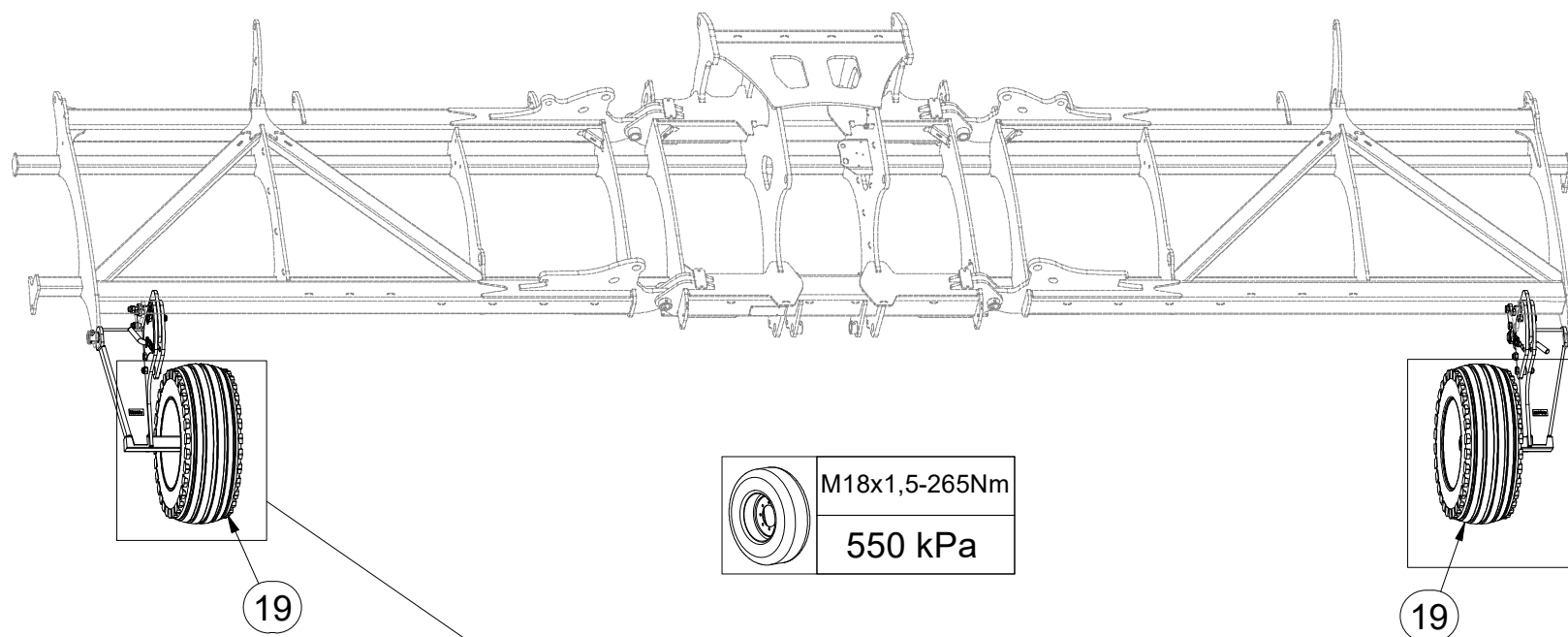

M18x1,5-265Nm  
550 kPa

Pos.	Part Number	Pcs.	Pos.	Part Number	Pcs.
1	VZ00020334	1	15	4011764	2
2	VZ00020335	1	19	m21946	2
3	VZ00019975	1	20	m13033	2
4	VZ00019977	1	21	m05747	6
5	4008355	2	22	m05723	6
6	VZ00019974	6	30	m04301	2
7	4008312	1	31	m05648	12
8	4008315	1	40	m10454	2
9	4017145	2	41	m15782	2
10	4015722	4	42	m12467	2
11	4017146	2	45	m04958	2

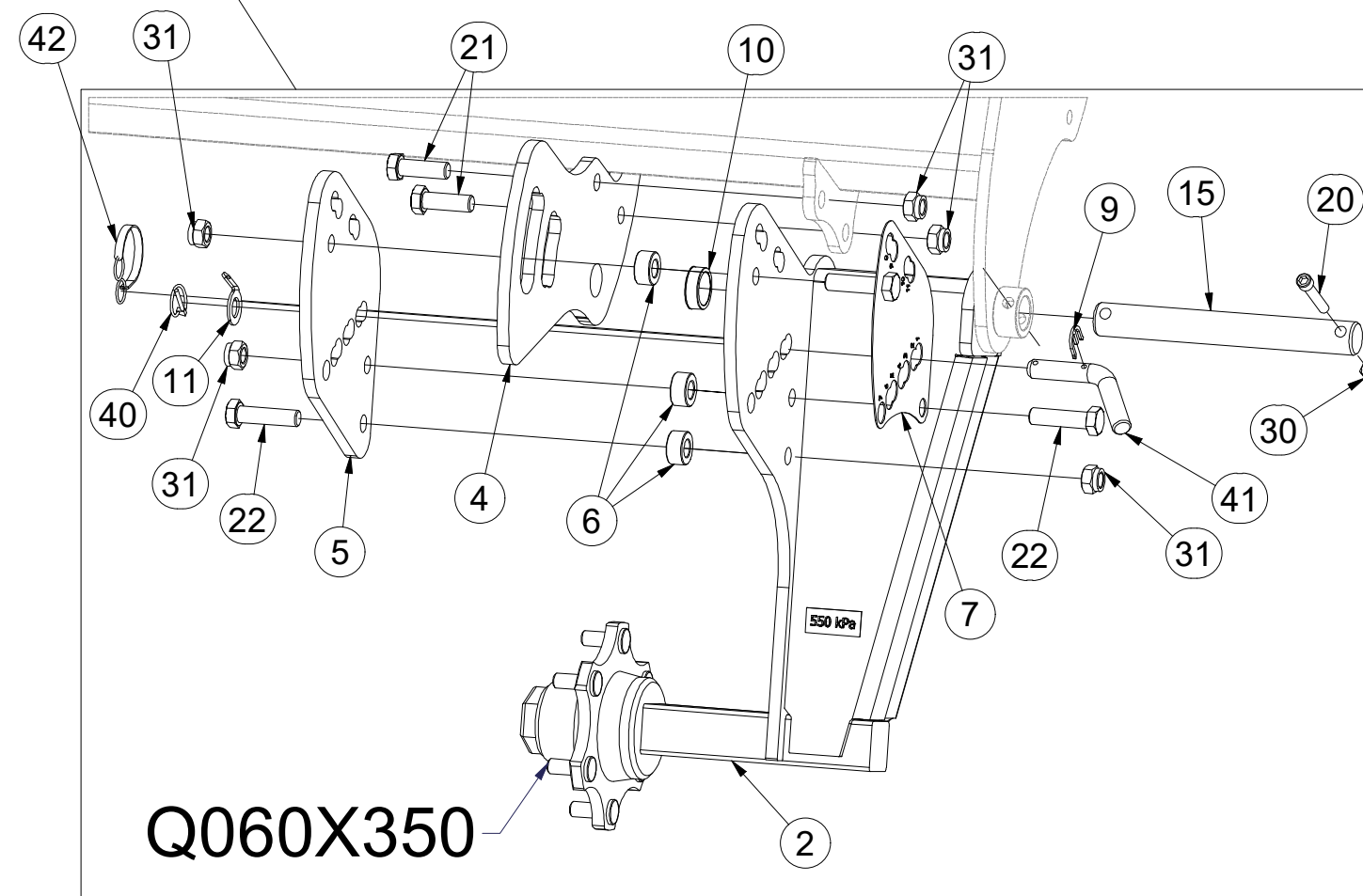
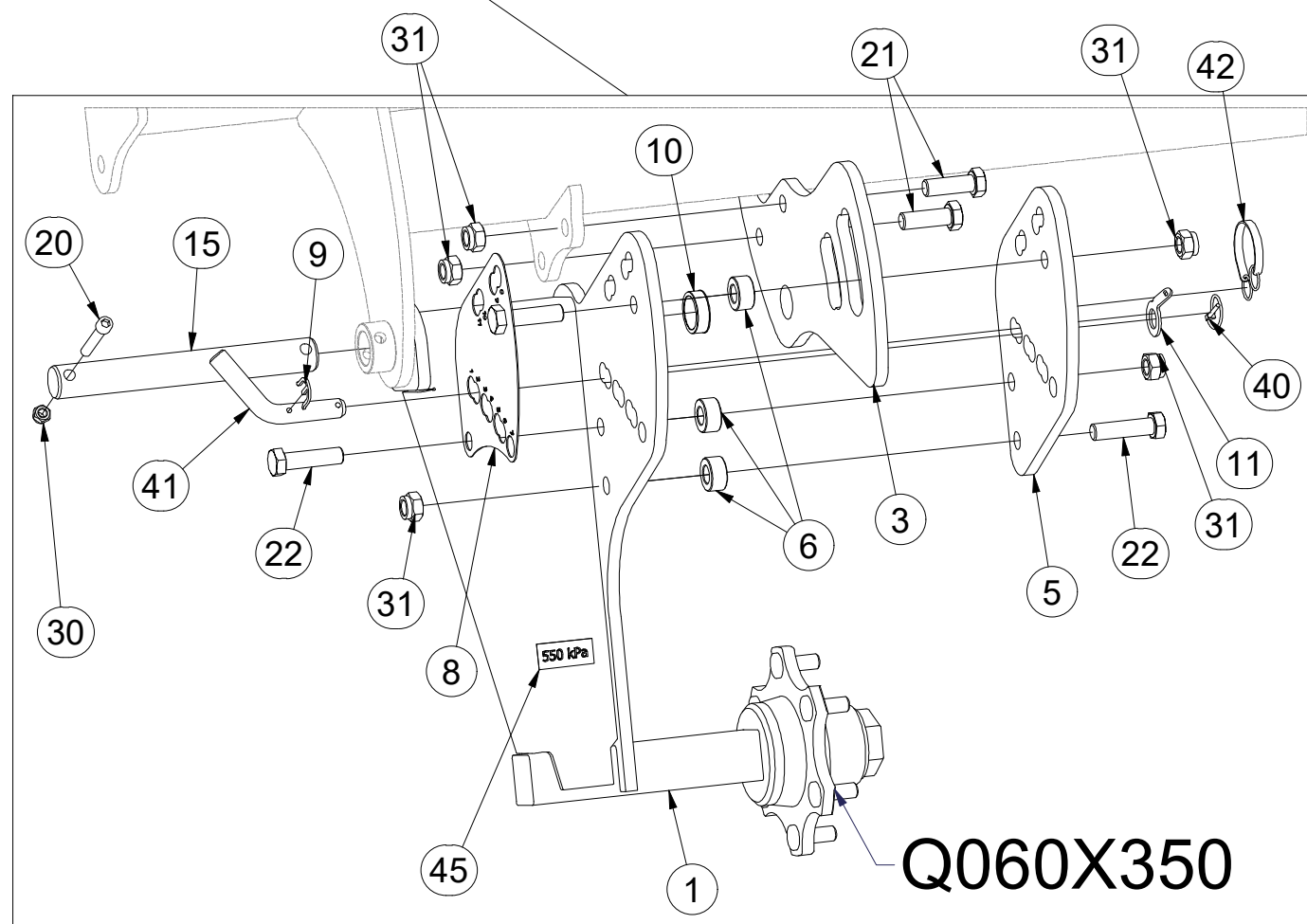

Ⓒ NÁPRAVA

Ⓓ ACHSE

Ⓕ ESSIEU

Ⓖ AXLE

Ⓡ OCB

Ⓟ OS



**Q060X350**

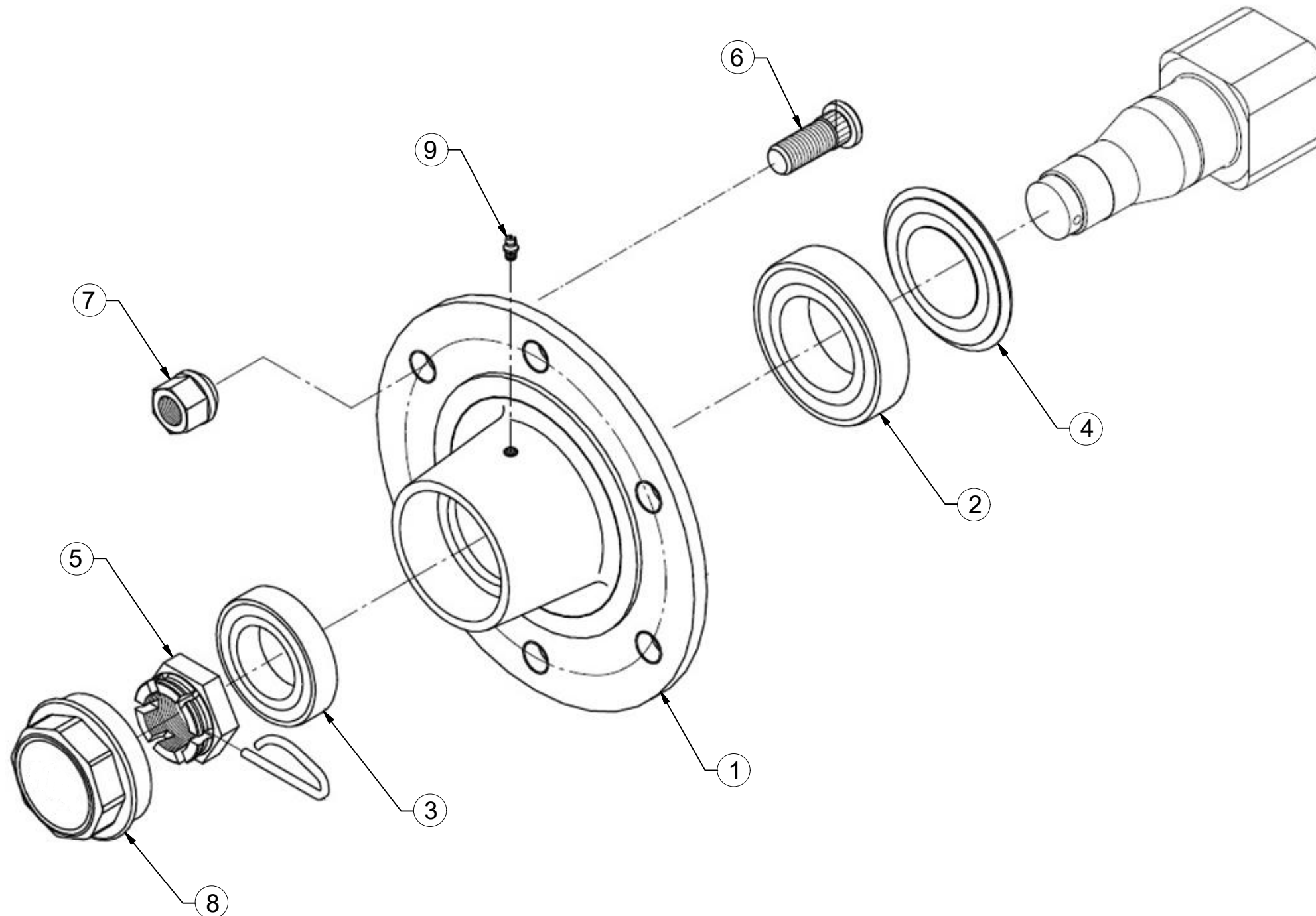

Pos.	Part Number	Pcs.
1	m21713	1
2	m07151	1
3	m07152	1
4	m21717	1
5	m08169	1
6	m08148	6
7	m08163	6
8	m21725	1
9	m05698	1

CZ SADA DISKŮ  
 D SCHEIBENSATZ  
 F KIT DE DISQUES

GB DISC SET  
 RU КОМПЛЕКТ ДИСКОВ  
 PL ZESTAW TALERZY



**VZ00024854**

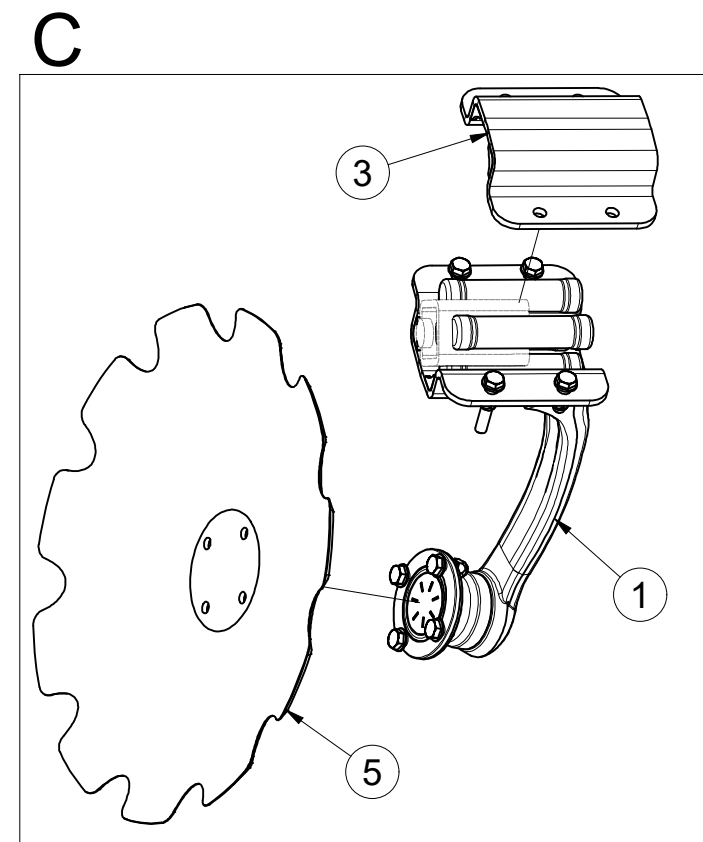
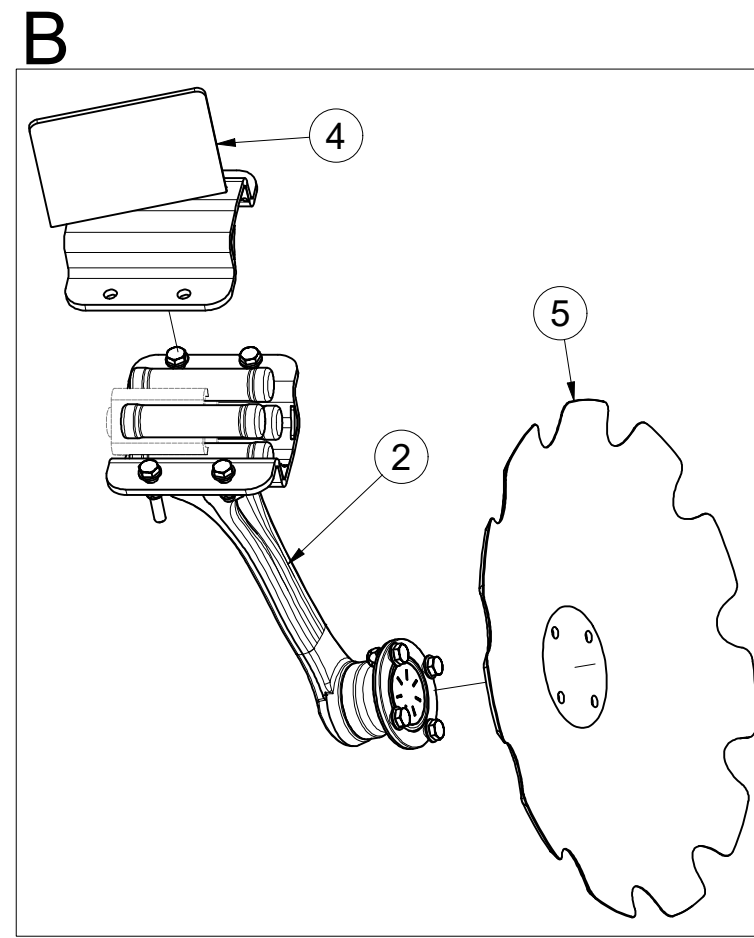
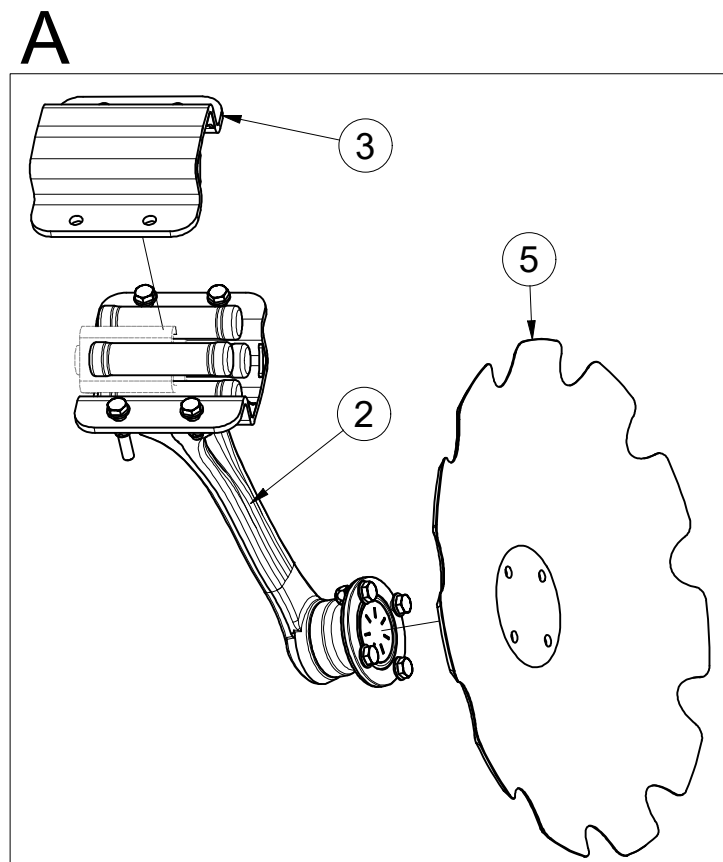
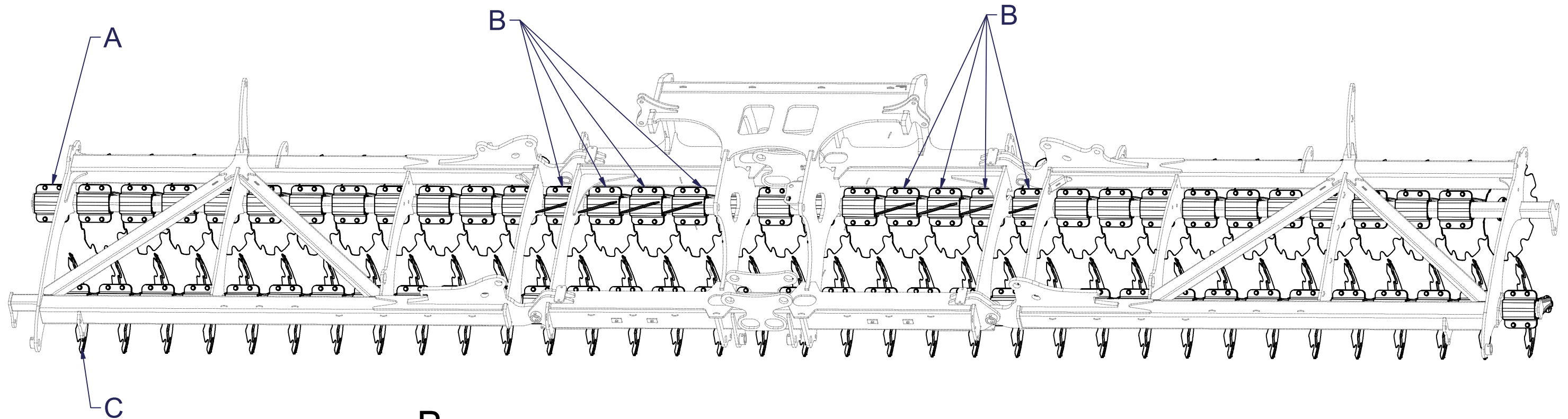

Pos.	Part Number	Pcs.
1	3008374	35
2	3008375	34
3	9004269	61
4	4016392	8
5	3006559	69

CZ PŘEDNÍ DISK  
 D SCHEIBE, VORDERE  
 F DISQUE AVANT

GB FRONT DISC  
 RU ДИСК ПЕРЕДНИЙ  
 PL TALERZ PRZEDNI



**3008374**

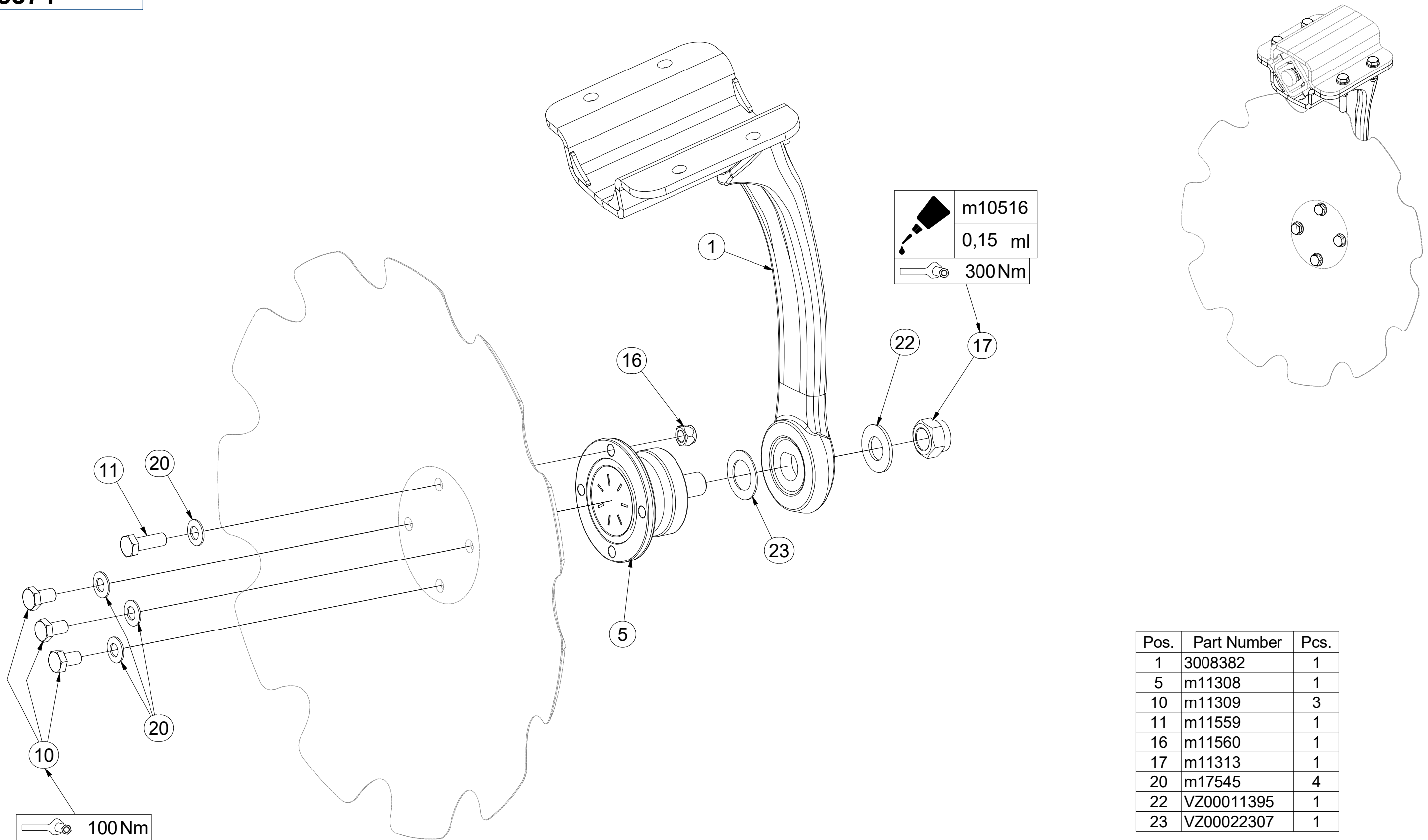

Pos.	Part Number	Pcs.
1	3008382	1
5	m11308	1
10	m11309	3
11	m11559	1
16	m11560	1
17	m11313	1
20	m17545	4
22	VZ00011395	1
23	VZ00022307	1

CZ PŘEDNÍ DISK  
 D SCHEIBE, VORDERE  
 F DISQUE AVANT

GB FRONT DISC  
 RU ДИСК ПЕРЕДНИЙ  
 PL TALERZ PRZEDNI



**3008374**

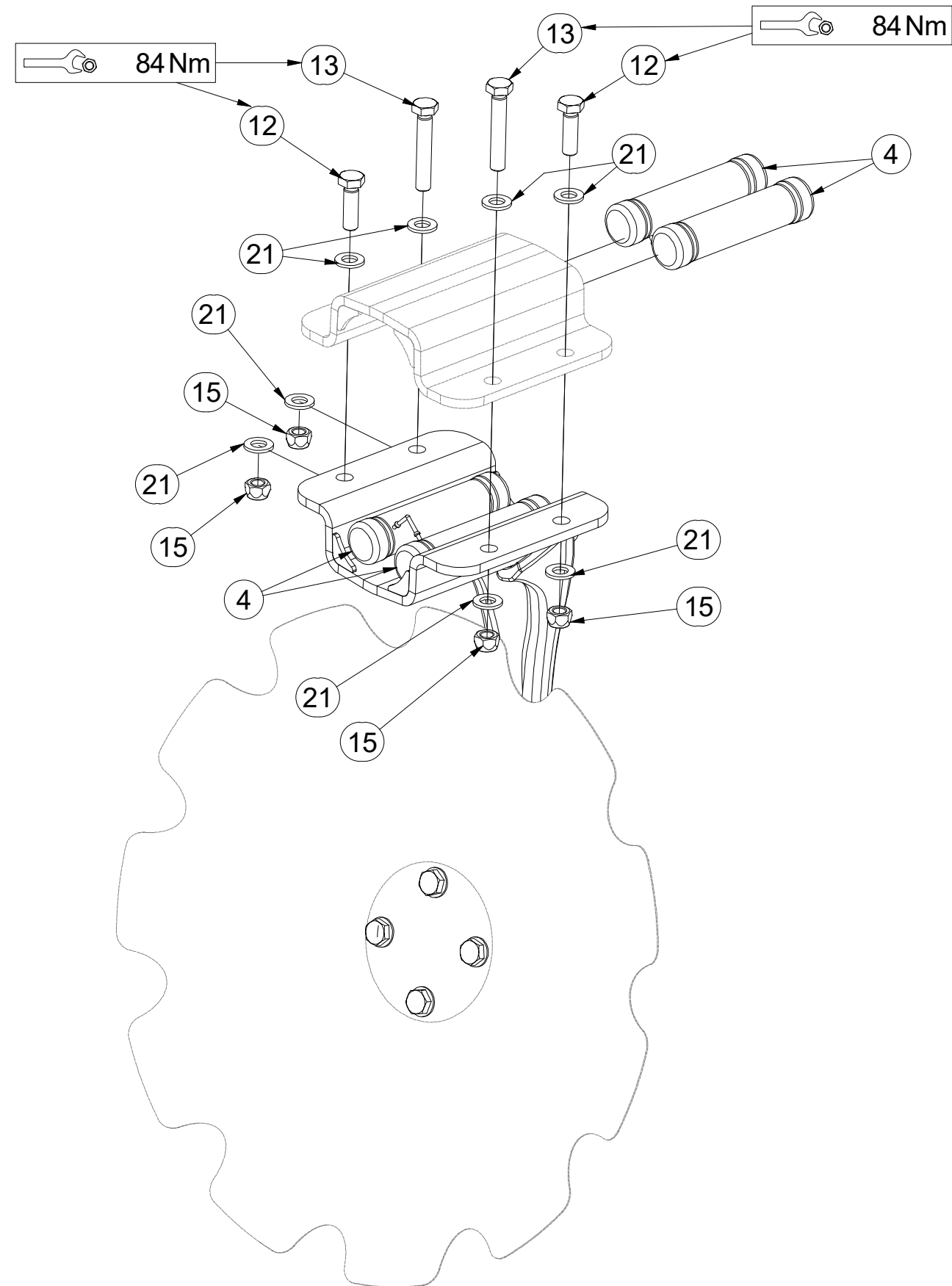

Pos.	Part Number	Pcs.
4	VZ00003901	4
12	m17657	2
13	m17653	2
15	m12134	4
21	m17741	8

CZ ZADNÍ DISK  
 D SCHEIBE, HINTERE  
 F DISQUE ARRIÈRE

GB REAR DISC  
 RU ДИСК ЗАДНИЙ  
 PL TALERZ TYLNY



**3008375**

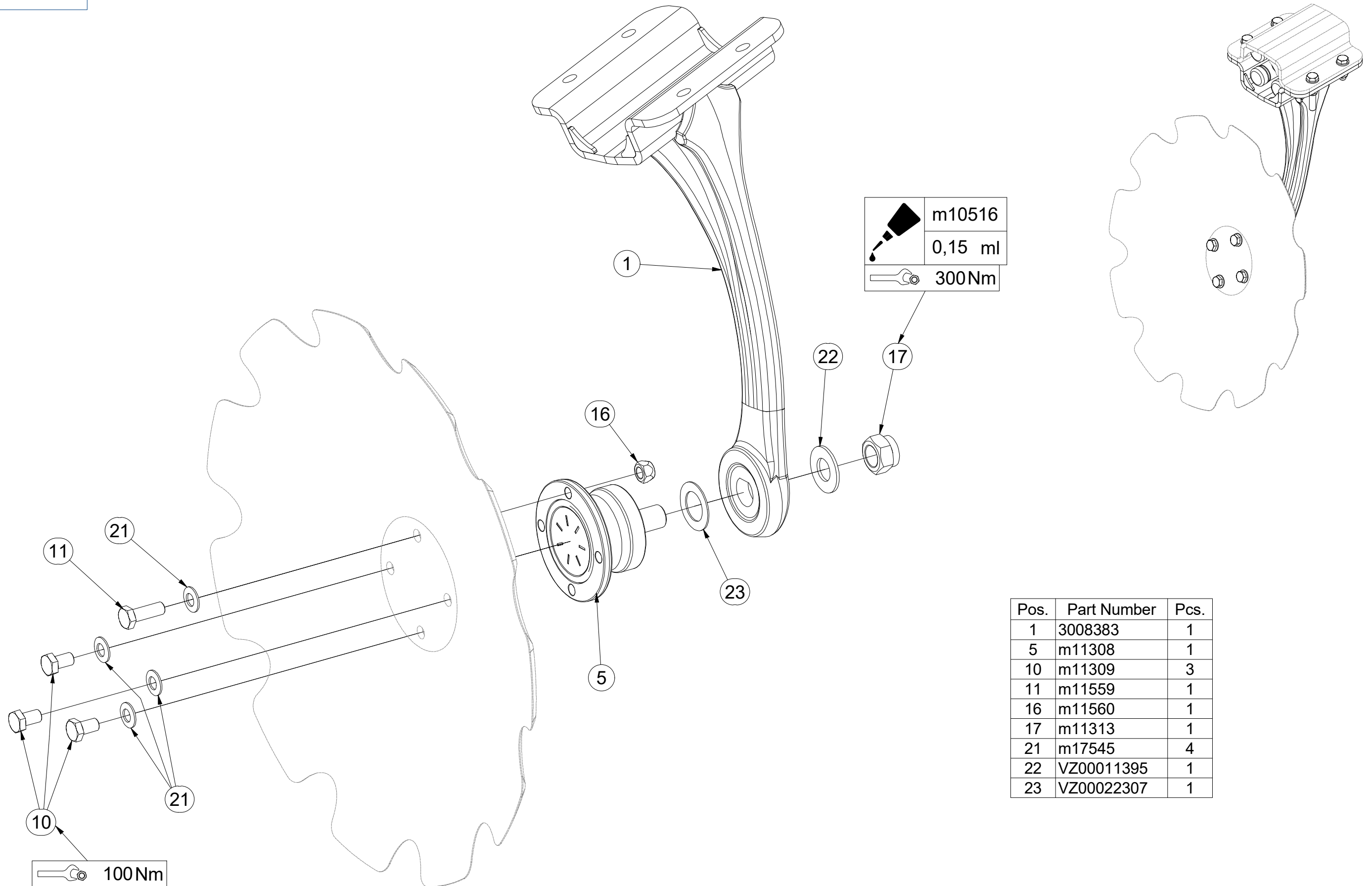

Pos.	Part Number	Pcs.
1	3008383	1
5	m11308	1
10	m11309	3
11	m11559	1
16	m11560	1
17	m11313	1
21	m17545	4
22	VZ00011395	1
23	VZ00022307	1



- Ⓒ ZADNÍ DISK
- Ⓓ SCHEIBE, HINTERE
- Ⓕ DISQUE ARRIÈRE

- Ⓒ REAR DISC
- Ⓓ ДИСК ЗАДНИЙ
- Ⓕ TALERZ TYLNY



**3008375**

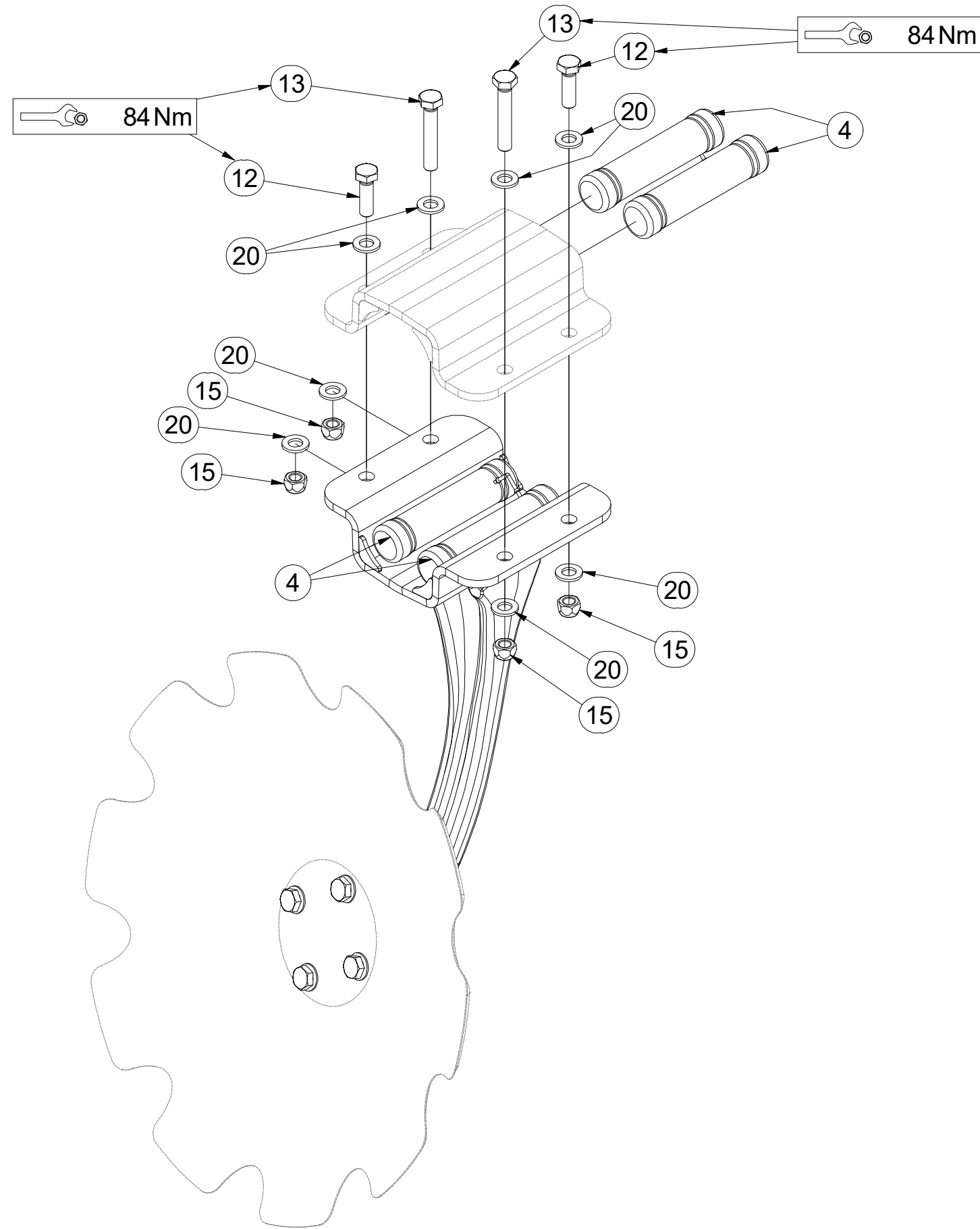

Pos.	Part Number	Pcs.
4	VZ00003901	4
12	m17657	2
13	m17653	2
15	m12134	4
20	m17741	8

CZ DEFLEKTOR LEVÝ  
 D DEFLEKTOR, LINKER  
 F DÉFLECTEUR GAUCHE

GB DEFLECTOR LEFT  
 RU ДЕФЛЕКТОР ЛЕВЫЙ  
 PL DEFLEKTOR LEWY



**3009574**

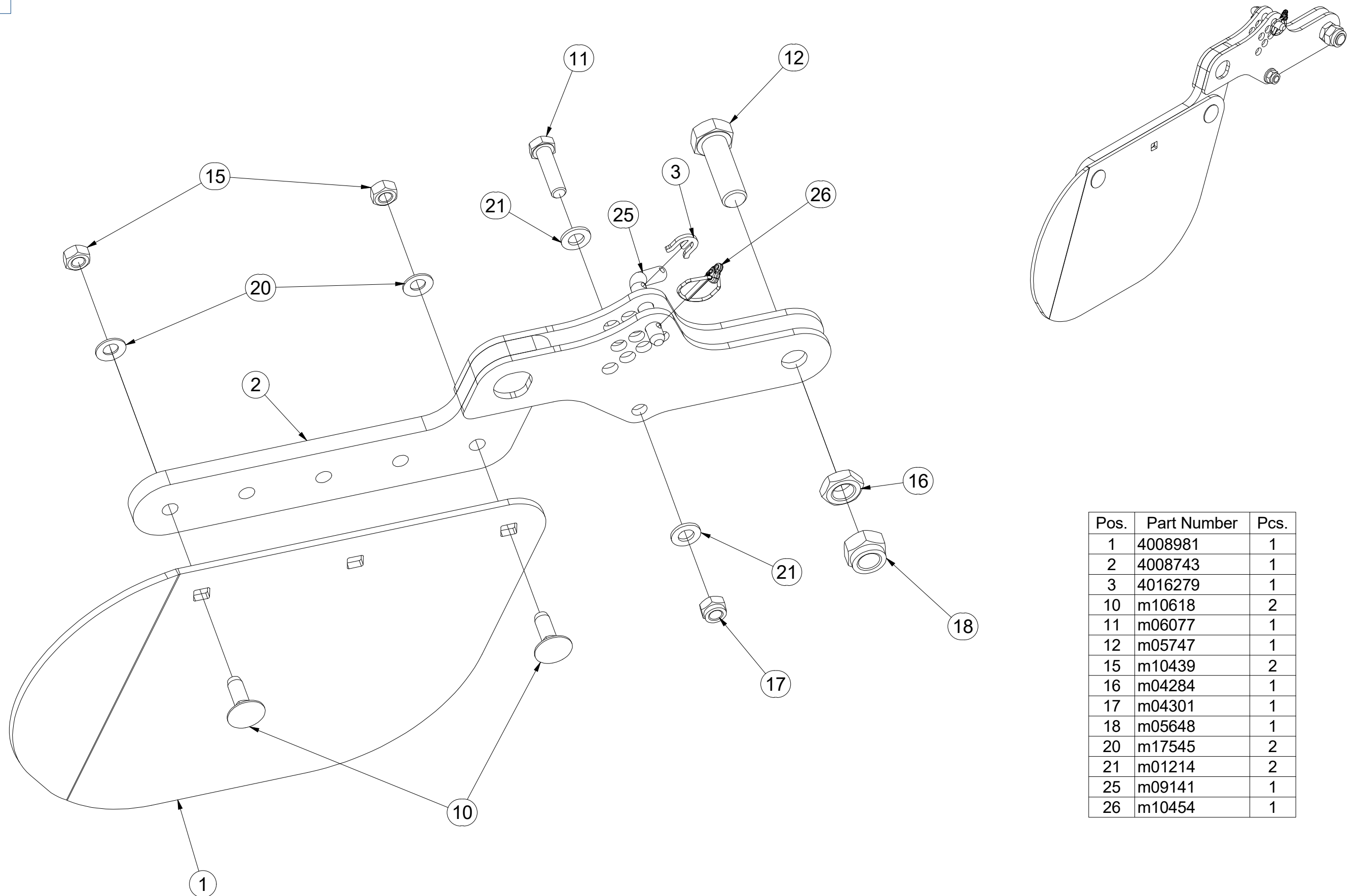

Pos.	Part Number	Pcs.
1	4008981	1
2	4008743	1
3	4016279	1
10	m10618	2
11	m06077	1
12	m05747	1
15	m10439	2
16	m04284	1
17	m04301	1
18	m05648	1
20	m17545	2
21	m01214	2
25	m09141	1
26	m10454	1

ⒸZ DEFLEKTOR PRAVÝ  
Ⓓ DEFLEKTOR, RECHTER  
Ⓕ DÉFLECTEUR DROIT

**VZ00022885**

ⒸGB DEFLECTOR RIGHT  
ⒸRU ДЕФЛЕКТОР ПРАВЫЙ  
ⒸPL DEFLEKTOR PRAWY

**Farmet**

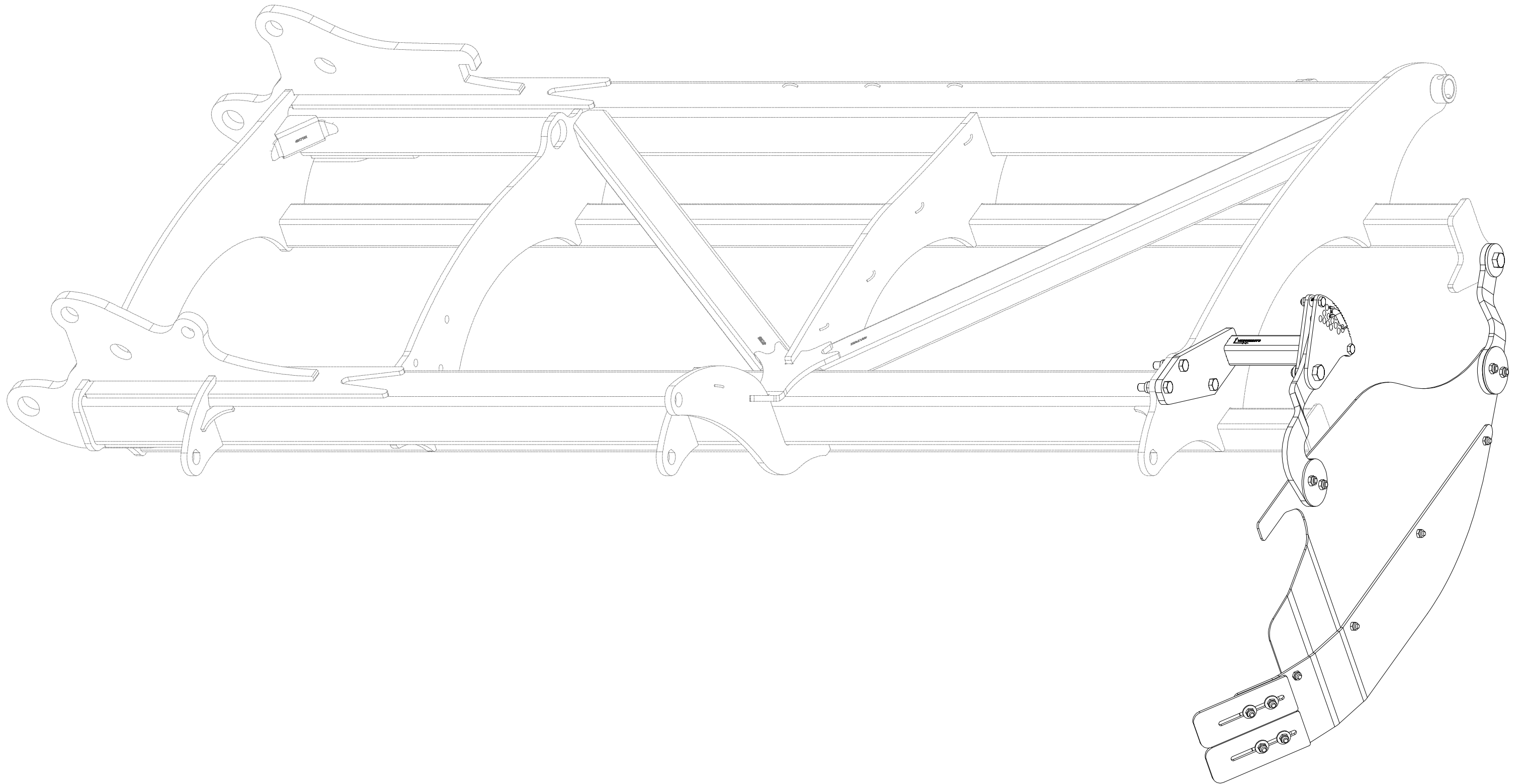

(CZ) DEFLEKTOR PRAVÝ  
 (D) DEFLEKTOR, RECHTER  
 (F) DÉFLECTEUR DROIT

(GB) DEFLECTOR RIGHT  
 (RU) ДЕФЛЕКТОР ПРАВЫЙ  
 (PL) DEFLEKTOR PRAWY



**VZ00022885**

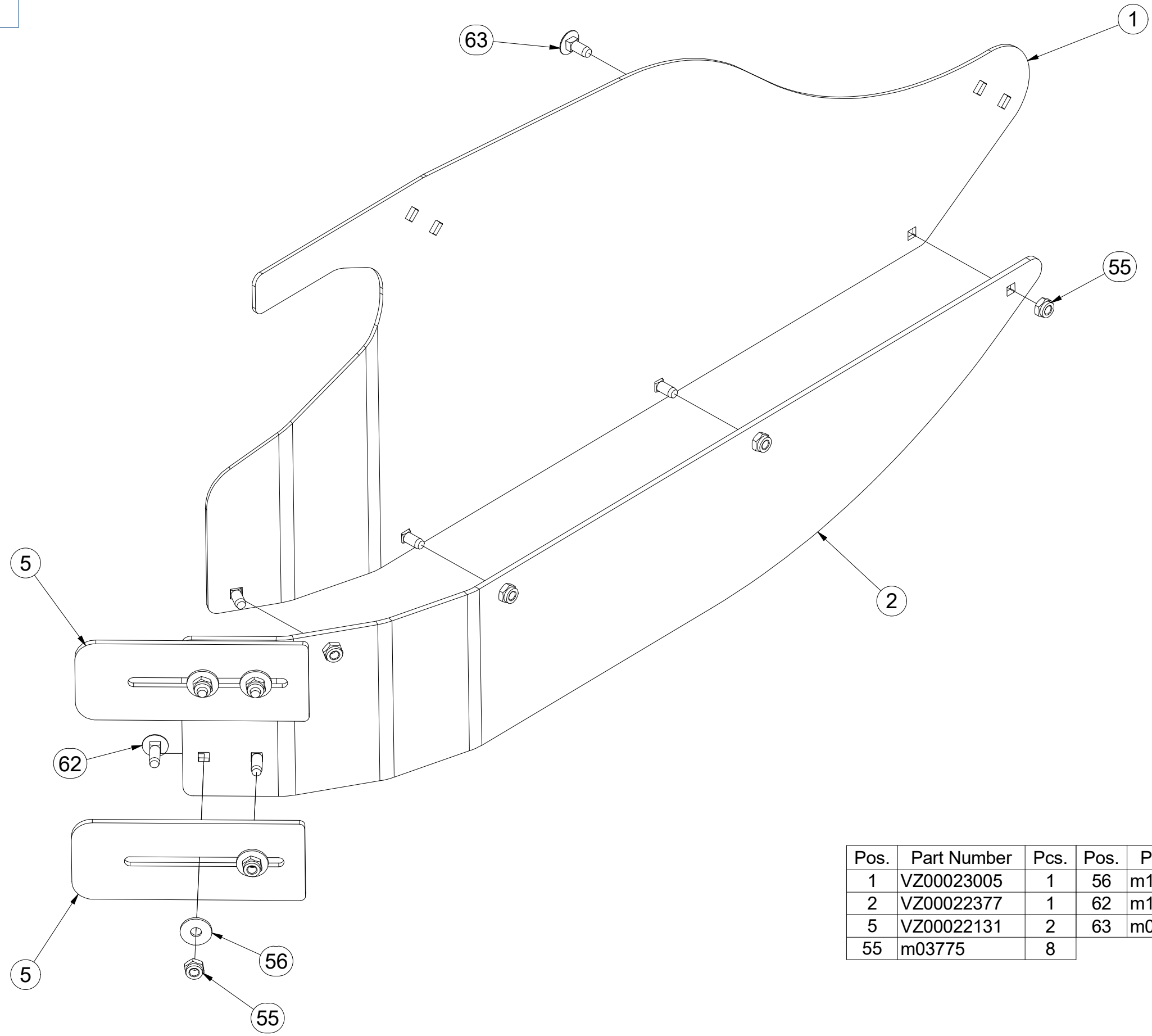

Pos.	Part Number	Pcs.	Pos.	Part Number	Pcs.
1	VZ00023005	1	56	m16981	4
2	VZ00022377	1	62	m19153	4
5	VZ00022131	2	63	m03129	4
55	m03775	8			

CZ DEFLEKTOR PRAVÝ  
 D DEFLEKTOR, RECHTER  
 F DÉFLECTEUR DROIT

GB DEFLECTOR RIGHT  
 RU ДЕФЛЕКТОР ПРАВЫЙ  
 PL DEFLEKTOR PRAWY



**VZ00022885**

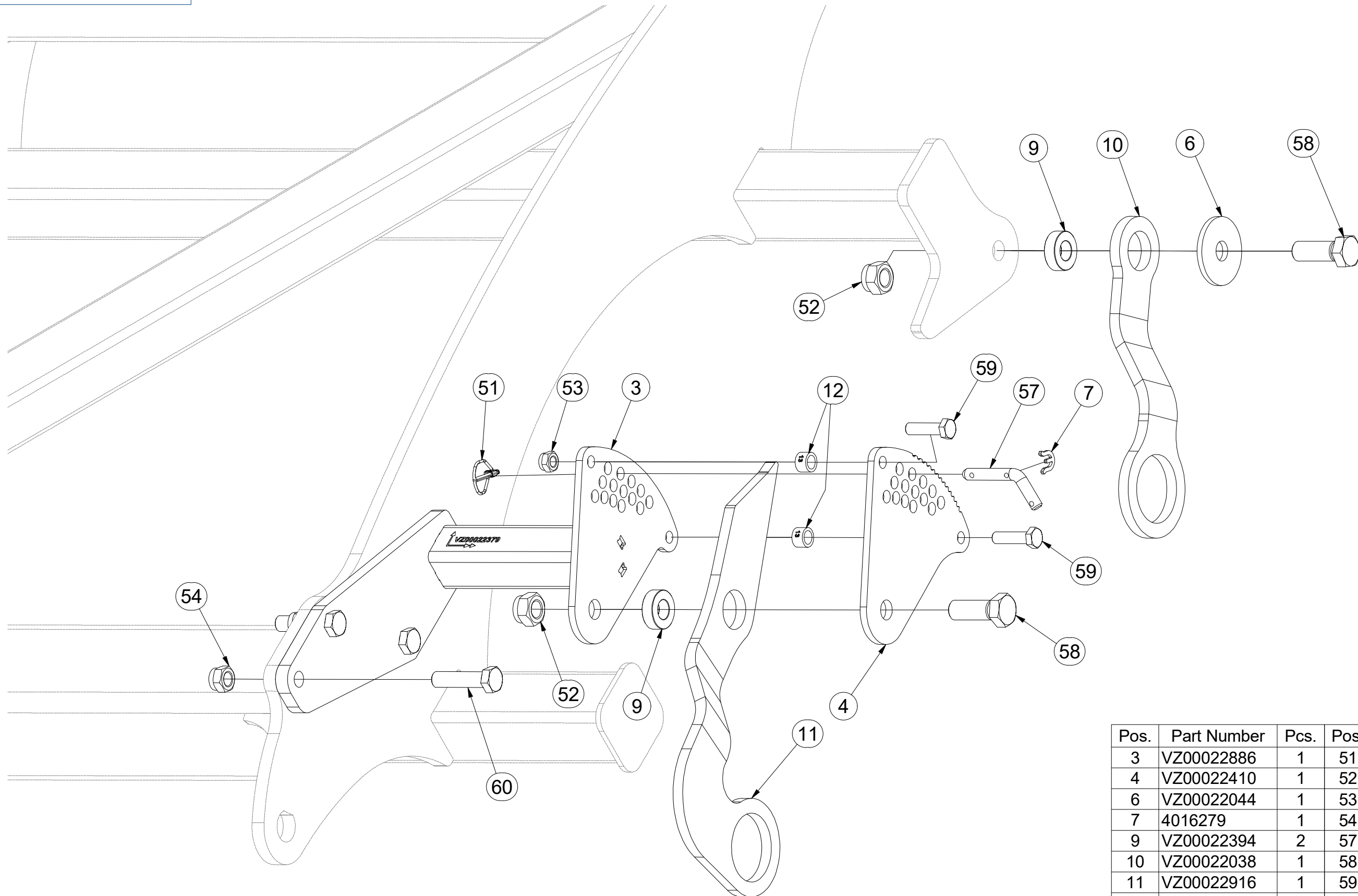

Pos.	Part Number	Pcs.	Pos.	Part Number	Pcs.
3	VZ00022886	1	51	m10454	1
4	VZ00022410	1	52	m05648	2
6	VZ00022044	1	53	m04301	6
7	4016279	1	54	m20385	3
9	VZ00022394	2	57	m09141	1
10	VZ00022038	1	58	m12771	2
11	VZ00022916	1	59	m06077	2
12	VZ00022102	2	60	m21355	3

- Ⓒ DEFLEKTOR PRAVÝ
- Ⓓ DEFLEKTOR, RECHTER
- Ⓕ DÉFLECTEUR DROIT

- Ⓖ DEFLECTOR RIGHT
- Ⓡ ДЕФЛЕКТОР ПРАВЫЙ
- Ⓟ DEFLEKTOR PRAWY



**VZ00022885**

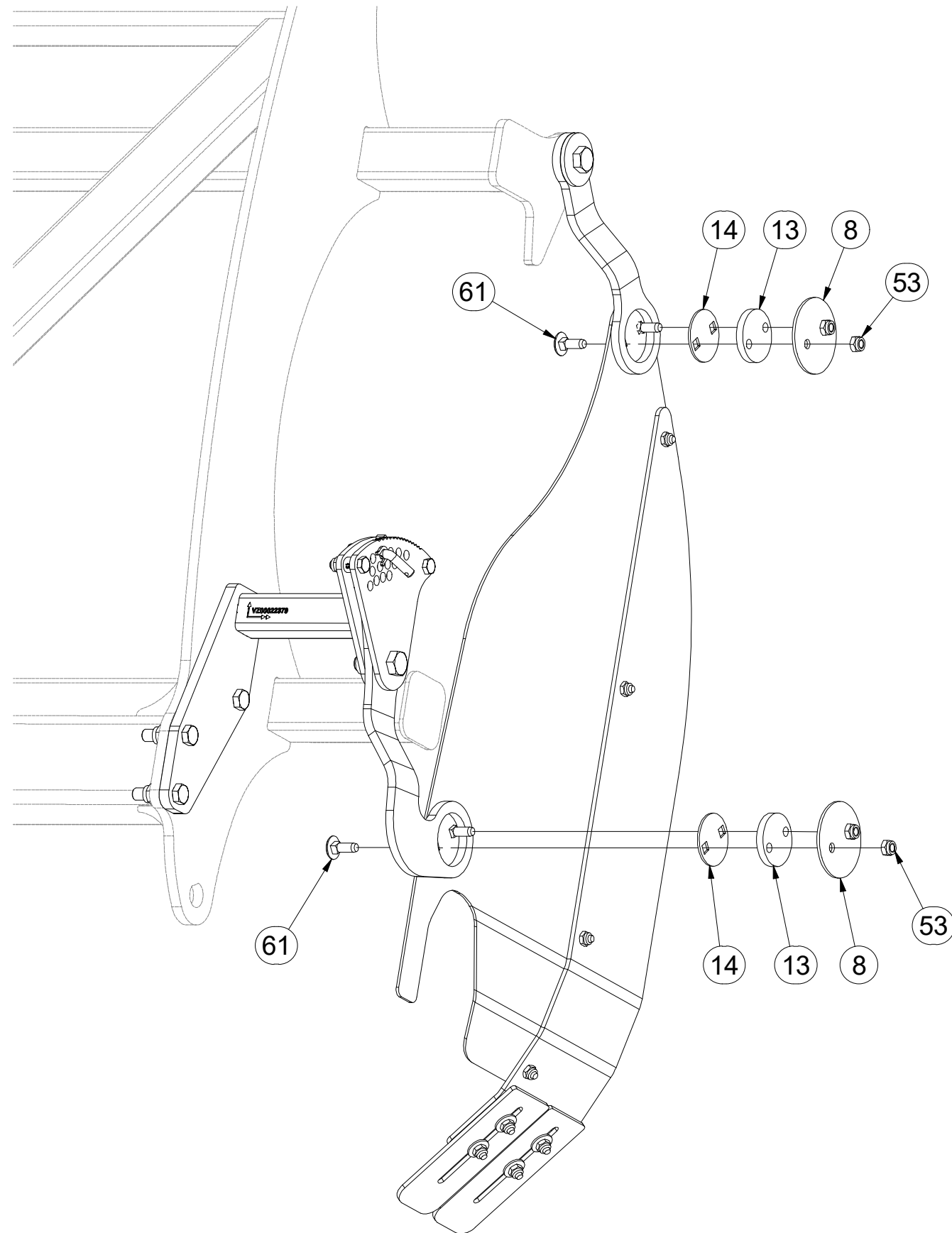

Pos.	Part Number	Pcs.
8	VZ00022433	2
13	VZ00022395	2
14	VZ00022432	2
53	m04301	6
61	m10618	4

- Ⓒ SADA ZADNÍCH VÁLCŮ
- Ⓓ SATZ HINTERE WALZEN
- Ⓕ KIT DE ROULEAUX ARRIÈRE

**VZ00019413**

- Ⓖ SET OF REAR ROLLERS
- Ⓡ КОМПЛЕКТ ЗАДНИХ КАТКОВ
- Ⓟ ZESTAW TYLNYCH WAŁÓW

**Farmet**

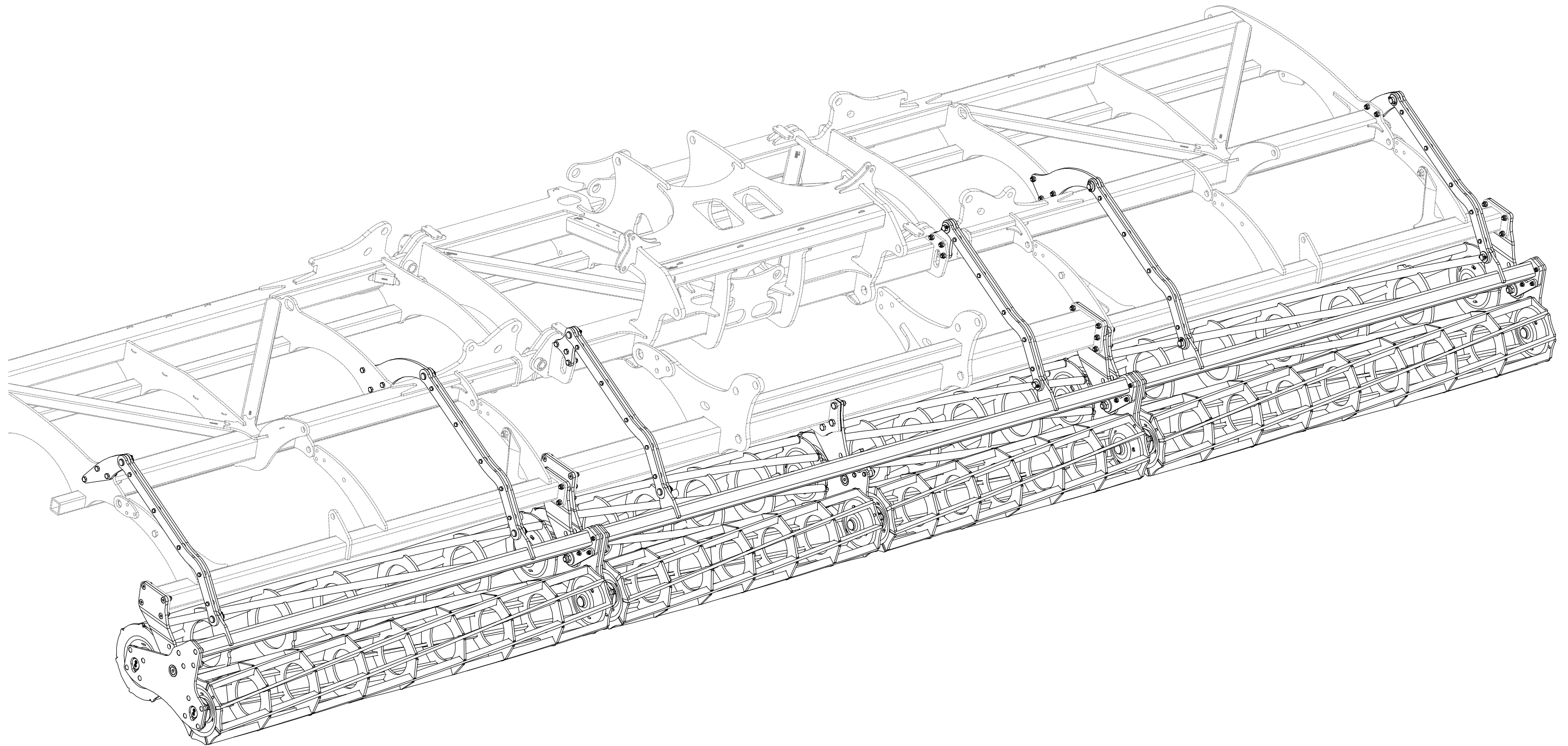

- ⒸZ SADA ZADNÍCH VÁLČŮ
- Ⓓ SATZ HINTERE WALZEN
- Ⓕ KIT DE ROULEAUX ARRIÈRE

- ⒼB SET OF REAR ROLLERS
- ⒶR КОМПЛЕКТ ЗАДНИХ КАТКОВ
- ⒶL ZESTAW TYLNYCH WAŁÓW



**VZ00019413**

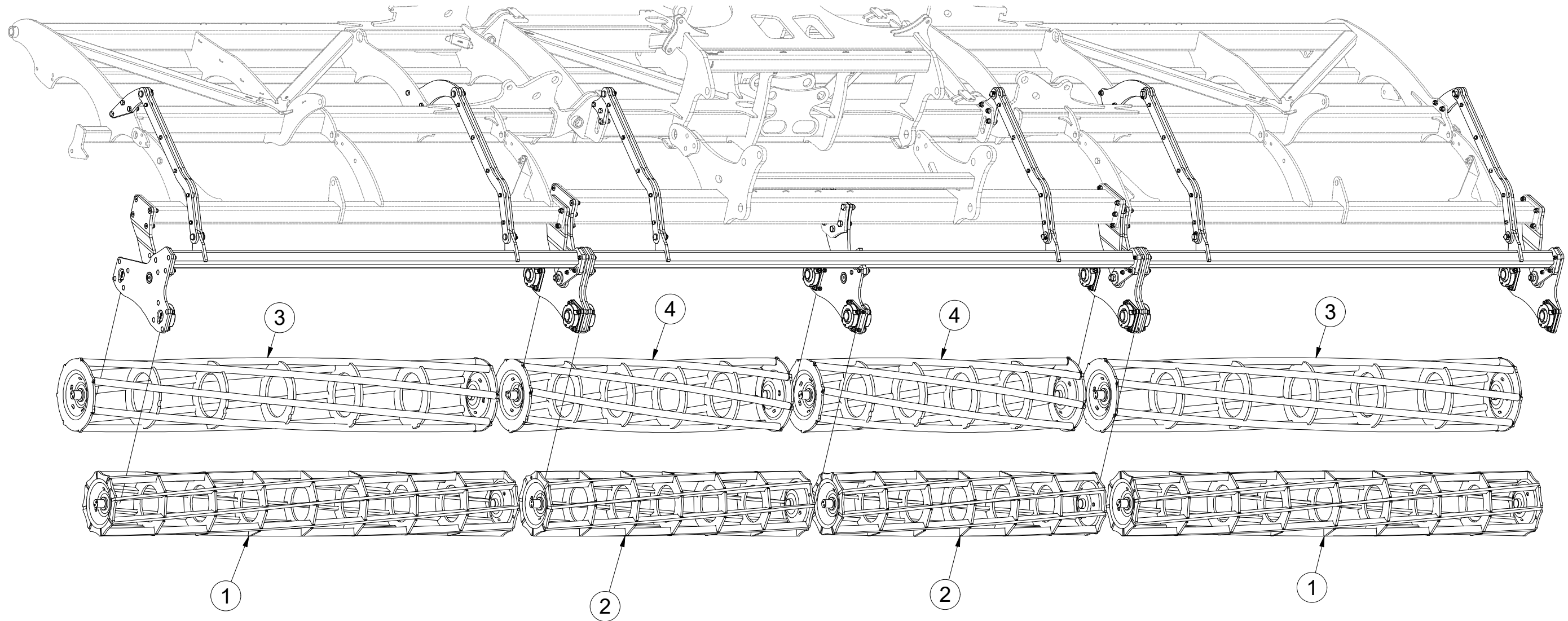

Pos.	Part Number	Pcs.
1	2000759	2
2	3007702	2
3	3010651	2
4	3010652	2



- Ⓒ SADA ZADNÍCH VÁLČŮ
- Ⓓ SATZ HINTERE WALZEN
- Ⓕ KIT DE ROULEAUX ARRIÈRE

- Ⓖ SET OF REAR ROLLERS
- Ⓡ КОМПЛЕКТ ЗАДНИХ КАТКОВ
- Ⓢ ZESTAW TYLNYCH WAŁÓW



**VZ00019413**

Pos.	Part Number	Pcs.	Pos.	Part Number	Pcs.
1	2000759	2	24	VZ00003521	14
3	3010651	2	36	m14991	7
7	VZ00018145	1	43	m19364	6
8	3008700	2	44	m19365	18
9	3008702	2	48	m14672	28
10	3008728	3	50	m14992	7
11	3008729	3	62	m04301	35
20	4015769	7	64	m03683	28
23	4015792	7	66	m07147	7

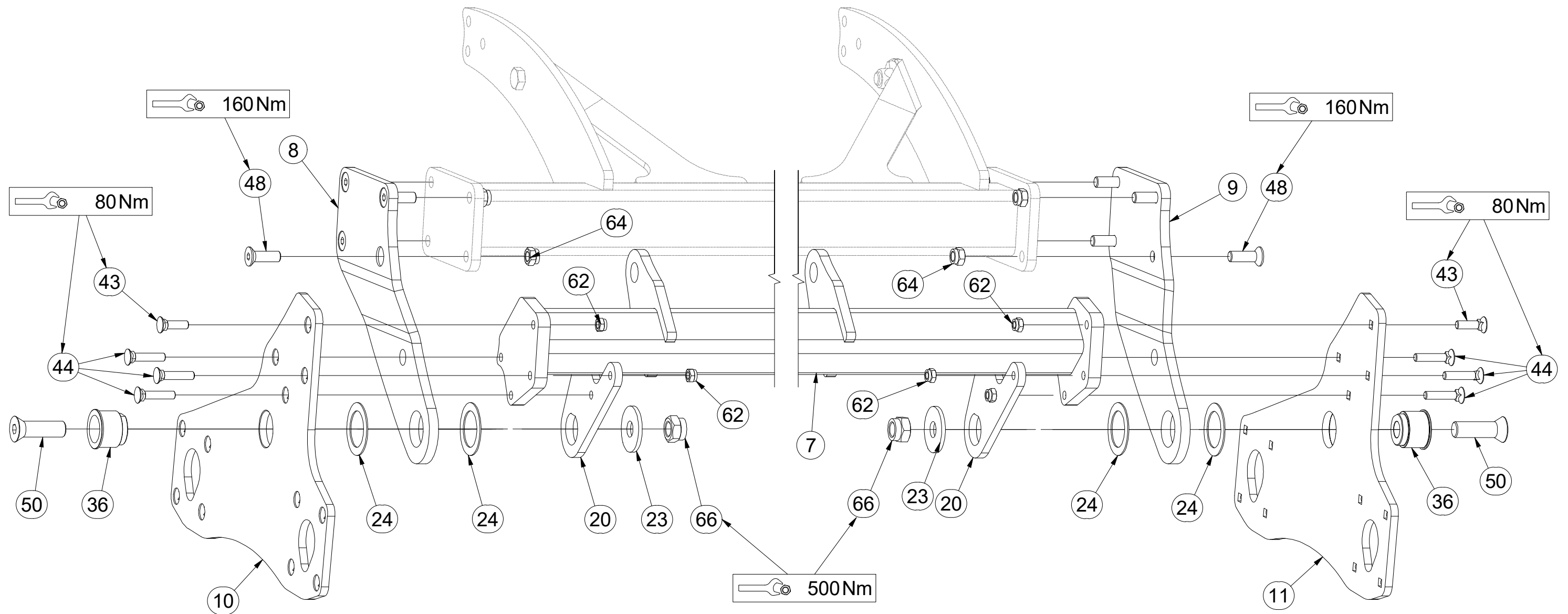
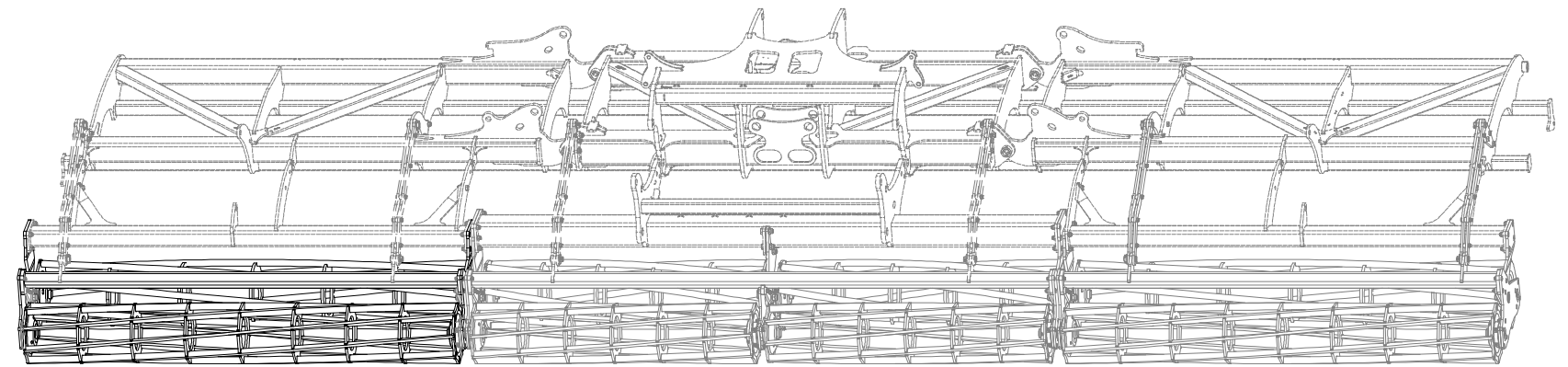

- Ⓒ SADA ZADNÍCH VÁLČŮ
- Ⓓ SATZ HINTERE WALZEN
- Ⓕ KIT DE ROULEAUX ARRIÈRE

- Ⓖ SET OF REAR ROLLERS
- Ⓡ КОМПЛЕКТ ЗАДНИХ КАТКОВ
- Ⓟ ZESTAW TYLNYCH WAŁÓW



**VZ00019413**

Pos.	Part Number	Pcs.	Pos.	Part Number	Pcs.
6	VZ00018146	1	36	m14991	7
8	3008700	2	43	m19364	6
9	3008702	2	44	m19365	18
10	3008728	3	48	m14672	28
11	3008729	3	50	m14992	7
20	4015769	7	62	m04301	35
23	4015792	7	64	m03683	28
24	VZ00003521	14	66	m07147	7

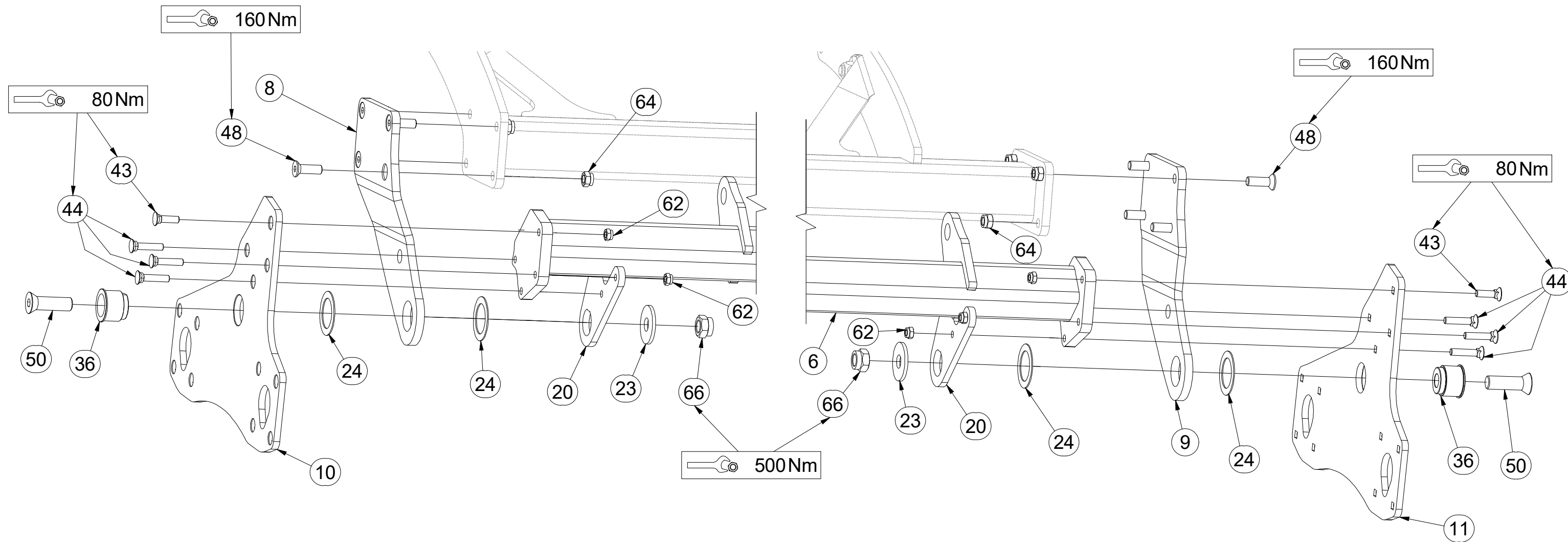
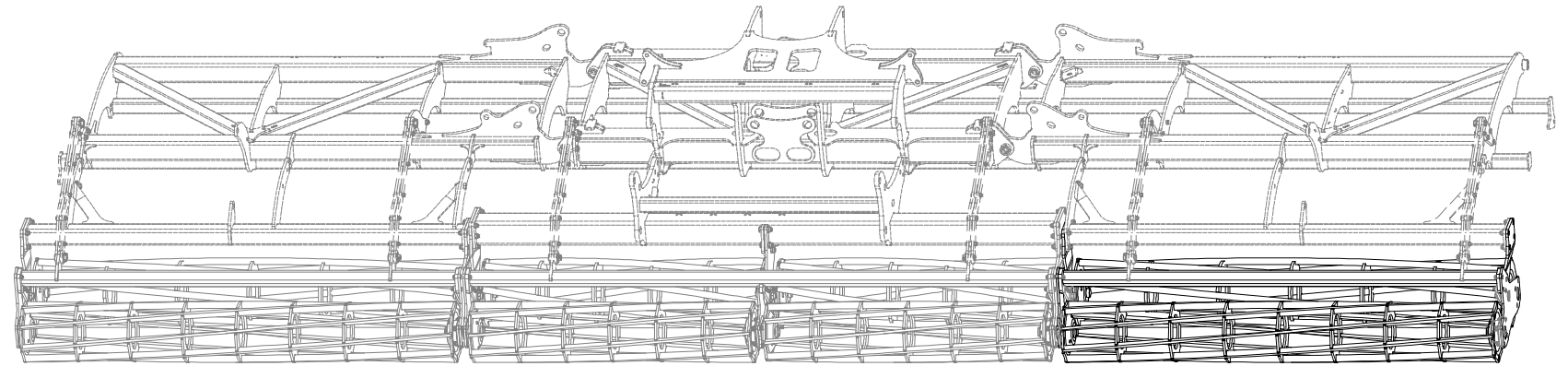

- Ⓒ SADA ZADNÍCH VÁLCŮ
- Ⓓ SATZ HINTERE WALZEN
- Ⓕ KIT DE ROULEAUX ARRIÈRE

- Ⓖ SET OF REAR ROLLERS
- Ⓡ КОМПЛЕКТ ЗАДНИХ КАТКОВ
- Ⓟ ZESTAW TYLNYCH WAŁÓW



**VZ00019413**

Pos.	Part Number	Pcs.	Pos.	Part Number	Pcs.
5	VZ00019421	1	36	m14991	7
10	3008728	3	43	m19364	6
11	3008729	3	44	m19365	18
13	VZ00003400	1	48	m14672	28
14	VZ00003401	1	50	m14992	7
20	4015769	7	62	m04301	35
23	4015792	7	66	m07147	7
24	VZ00003521	14	64	m03683	28

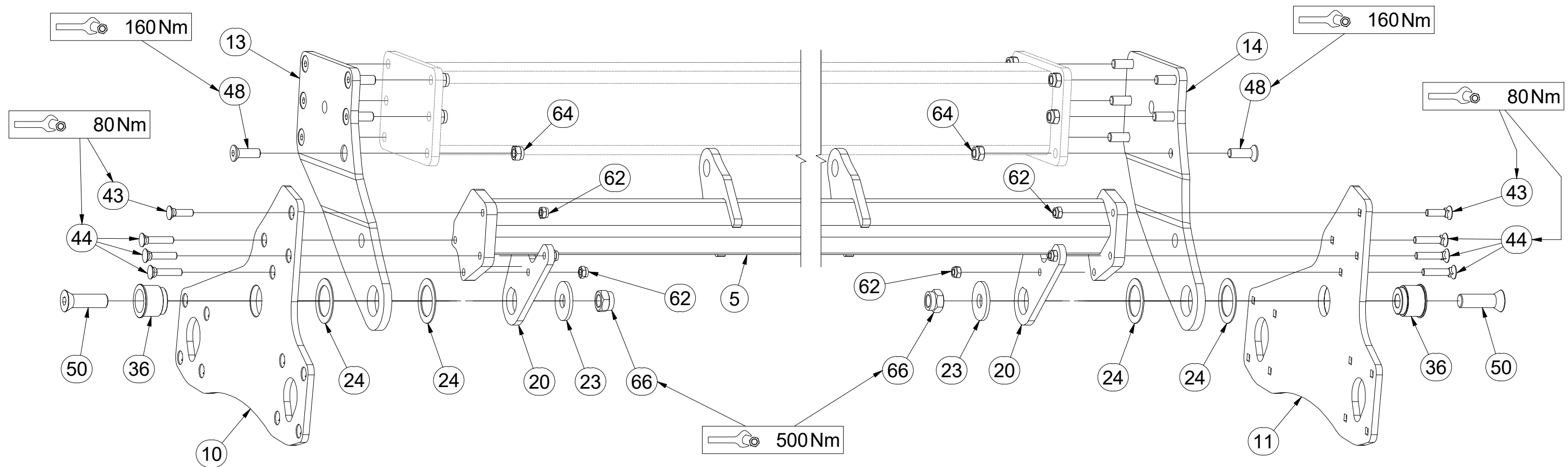
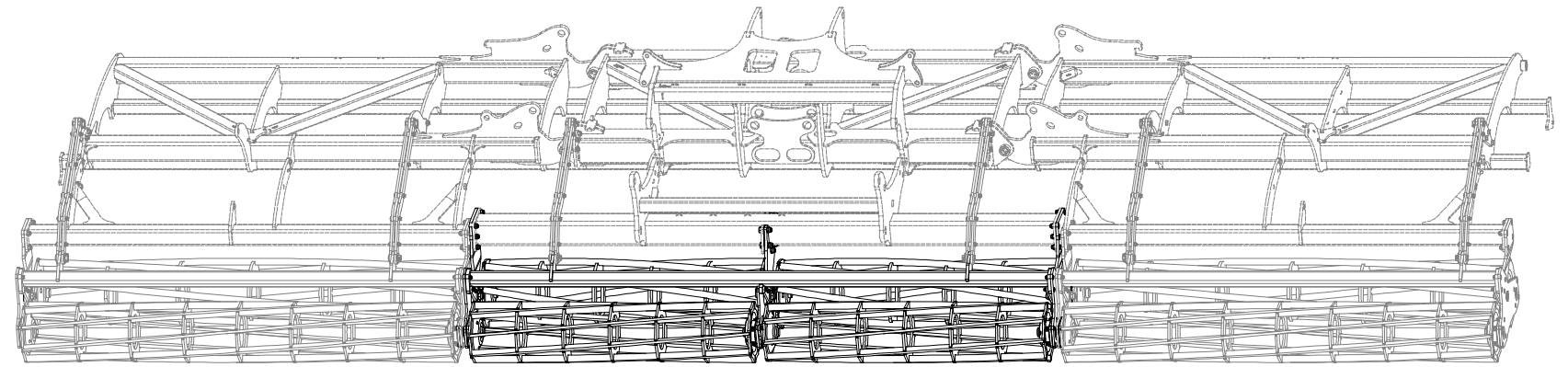

- Ⓒ SADA ZADNÍCH VÁLCŮ
- Ⓓ SATZ HINTERE WALZEN
- Ⓕ KIT DE ROULEAUX ARRIÈRE

- Ⓖ SET OF REAR ROLLERS
- Ⓡ КОМПЛЕКТ ЗАДНИХ КАТКОВ
- Ⓟ ZESTAW TYLNYCH WAŁÓW



**VZ00019413**

Pos.	Part Number	Pcs.	Pos.	Part Number	Pcs.
5	VZ00019421	1	36	m14991	7
12	VZ00003378	1	45	m12137	3
15	VZ00016910	1	49	m14496	6
20	4015769	7	50	m14992	7
22	VZ00016939	1	62	m04301	35
23	4015792	7	66	m07147	7
24	VZ00003521	14	65	m21660	6

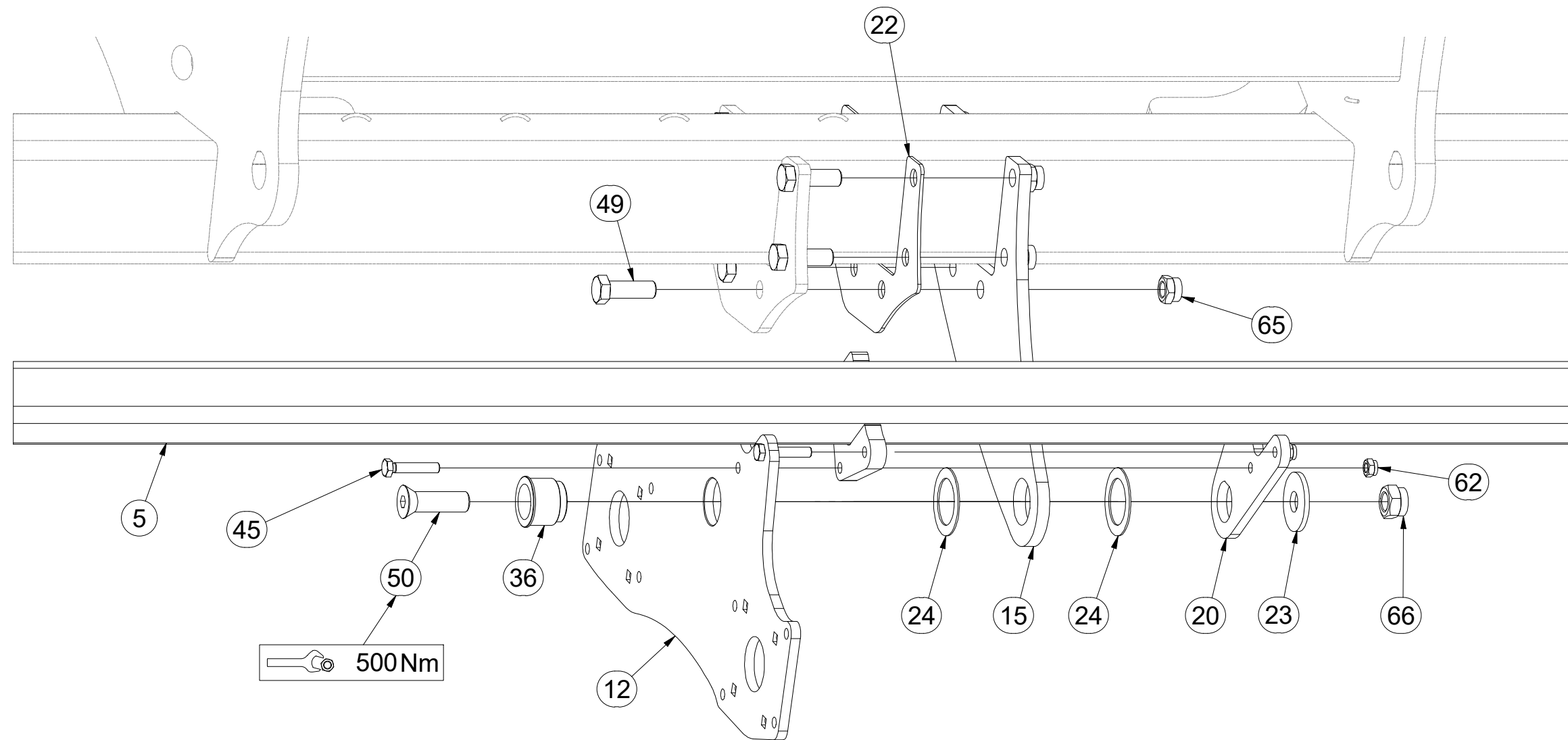
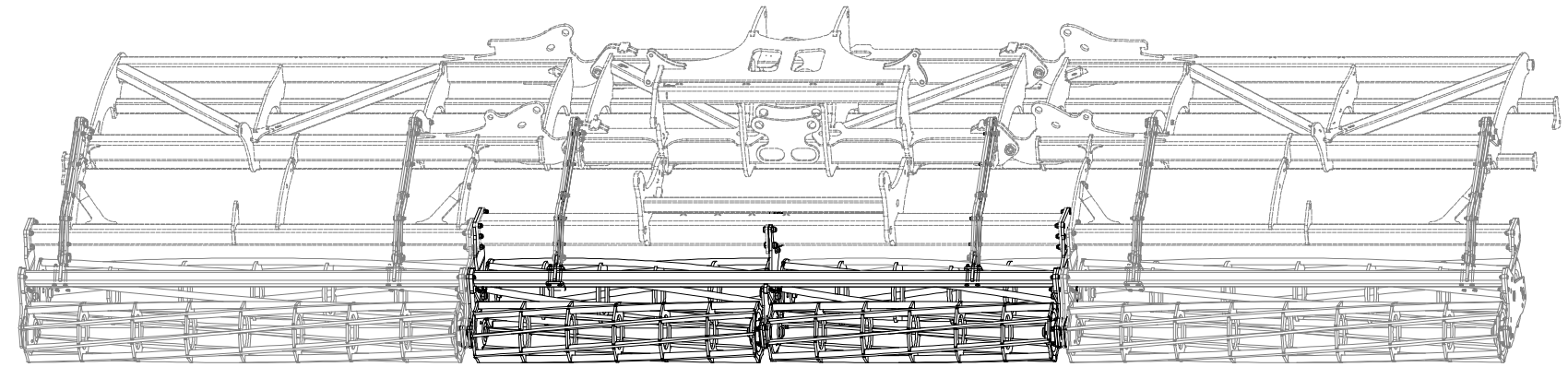

- Ⓒ SADA ZADNÍCH VÁLČŮ
- Ⓓ SATZ HINTERE WALZEN
- Ⓕ KIT DE ROULEAUX ARRIÈRE

- Ⓖ SET OF REAR ROLLERS
- Ⓡ КОМПЛЕКТ ЗАДНИХ КАТКОВ
- Ⓟ ZESTAW TYLNYCH WAŁÓW



**VZ00019413**

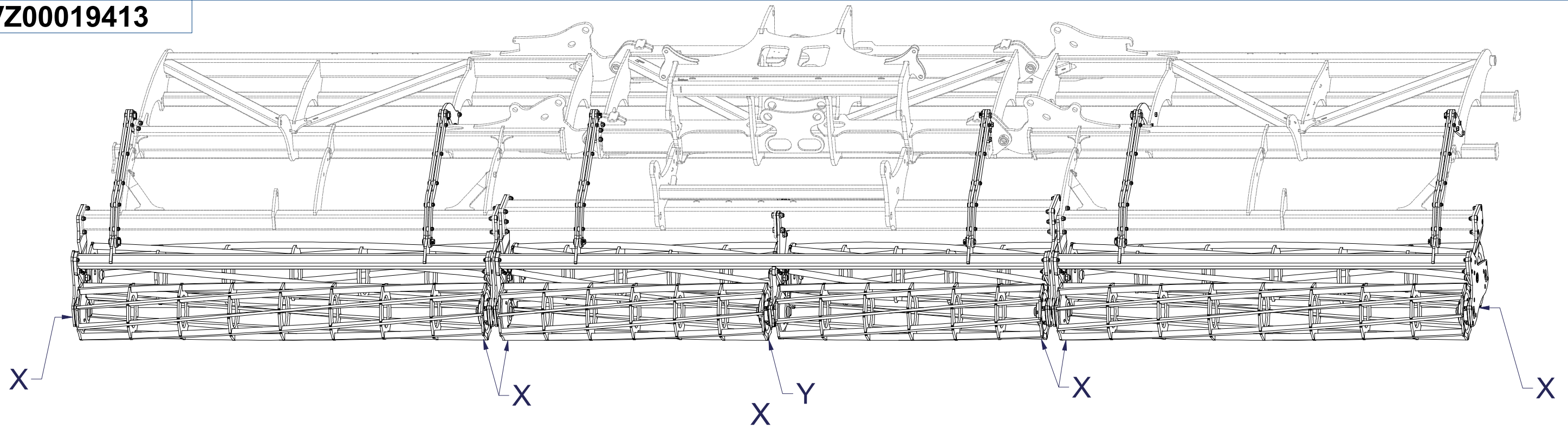

Pos.	Part Number	Pcs.
25	4017124	16
34	4016002	24
35	m17627	16
41	m17638	32
42	m11154	64
61	m10439	64
70	m01208	32
71	m17545	64

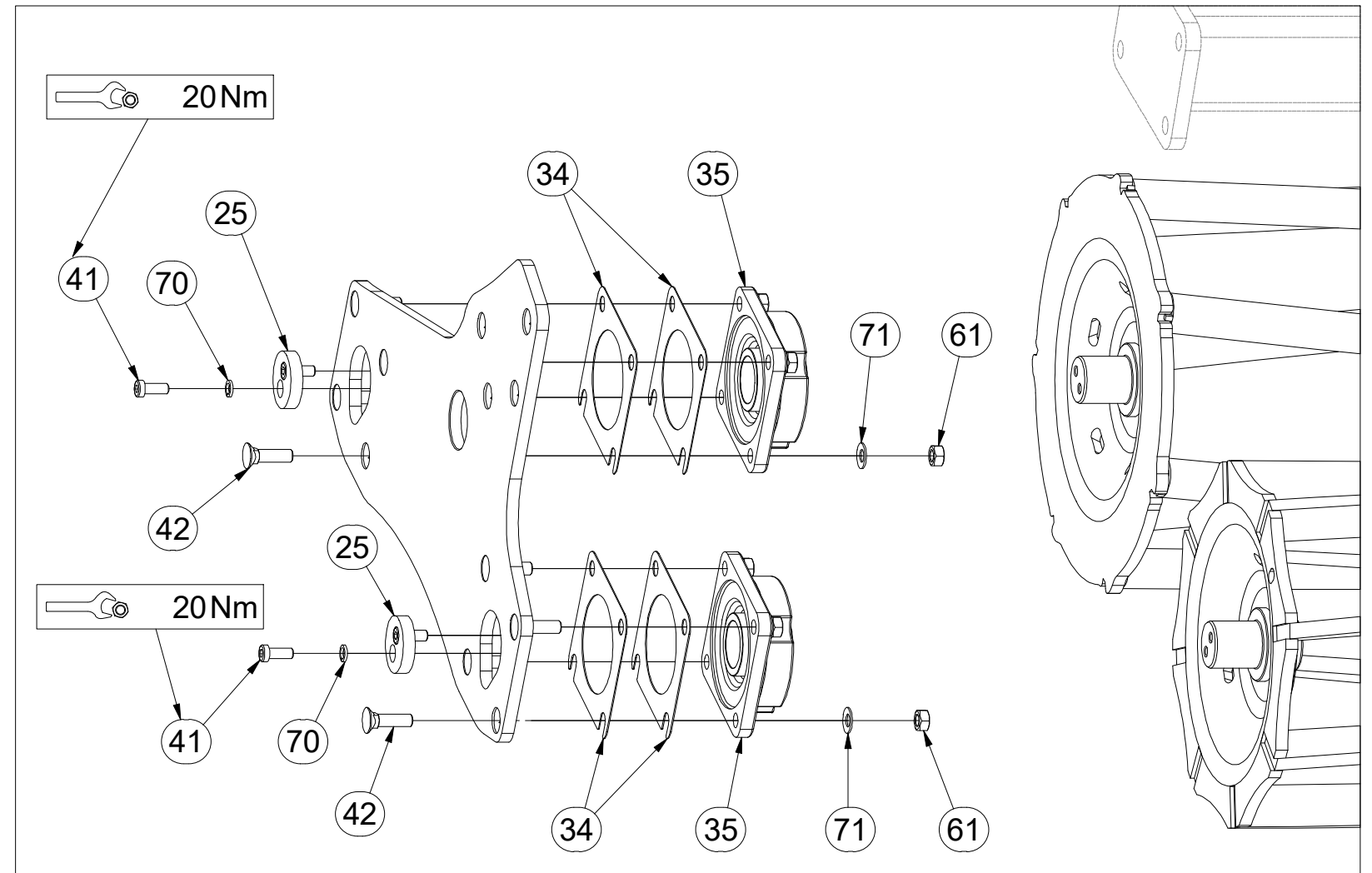

- Ⓒ SADA ZADNÍCH VÁLCŮ
- Ⓓ SATZ HINTERE WALZEN
- Ⓕ KIT DE ROULEAUX ARRIÈRE

- Ⓖ SET OF REAR ROLLERS
- Ⓡ КОМПЛЕКТ ЗАДНИХ КАТКОВ
- Ⓟ ZESTAW TYLNYCH WAŁÓW



**VZ00019413**

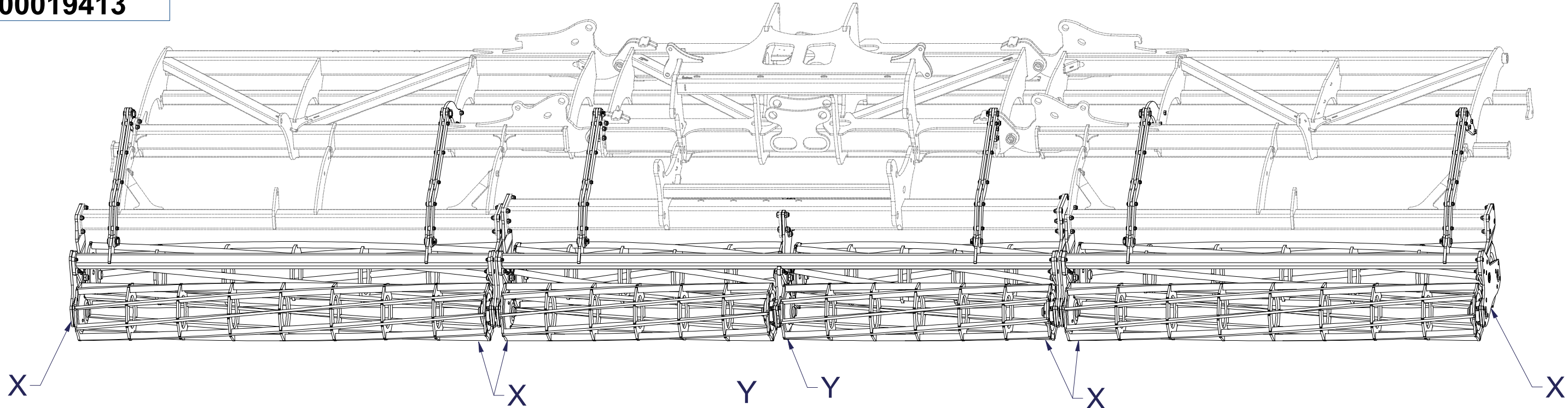

Pos.	Part Number	Pcs.
21	4025839	2
25	4017124	16
35	m17627	16
41	m17638	32
42	m11154	64
46	m17657	8
61	m10439	64
62	m04301	35
70	m01208	32
71	m17545	64

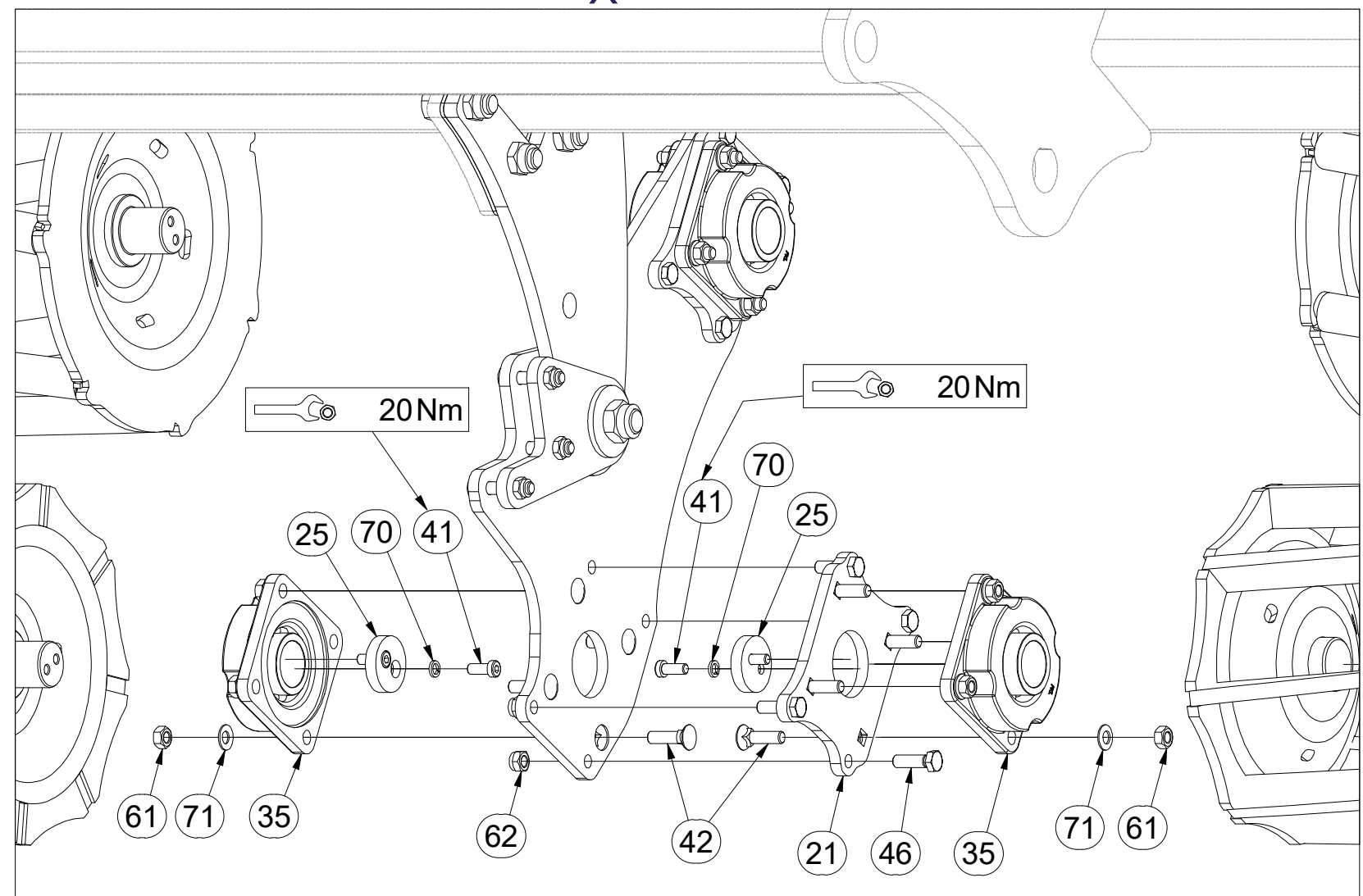

- ⒸZ SADA ZADNÍCH VÁLCŮ
- Ⓓ SATZ HINTERE WALZEN
- Ⓕ KIT DE ROULEAUX ARRIÈRE

- ⒼB SET OF REAR ROLLERS
- ⒼR КОМПЛЕКТ ЗАДНИХ КАТКОВ
- ⒼL ZESTAW TYLNYCH WAŁÓW



**VZ00019413**

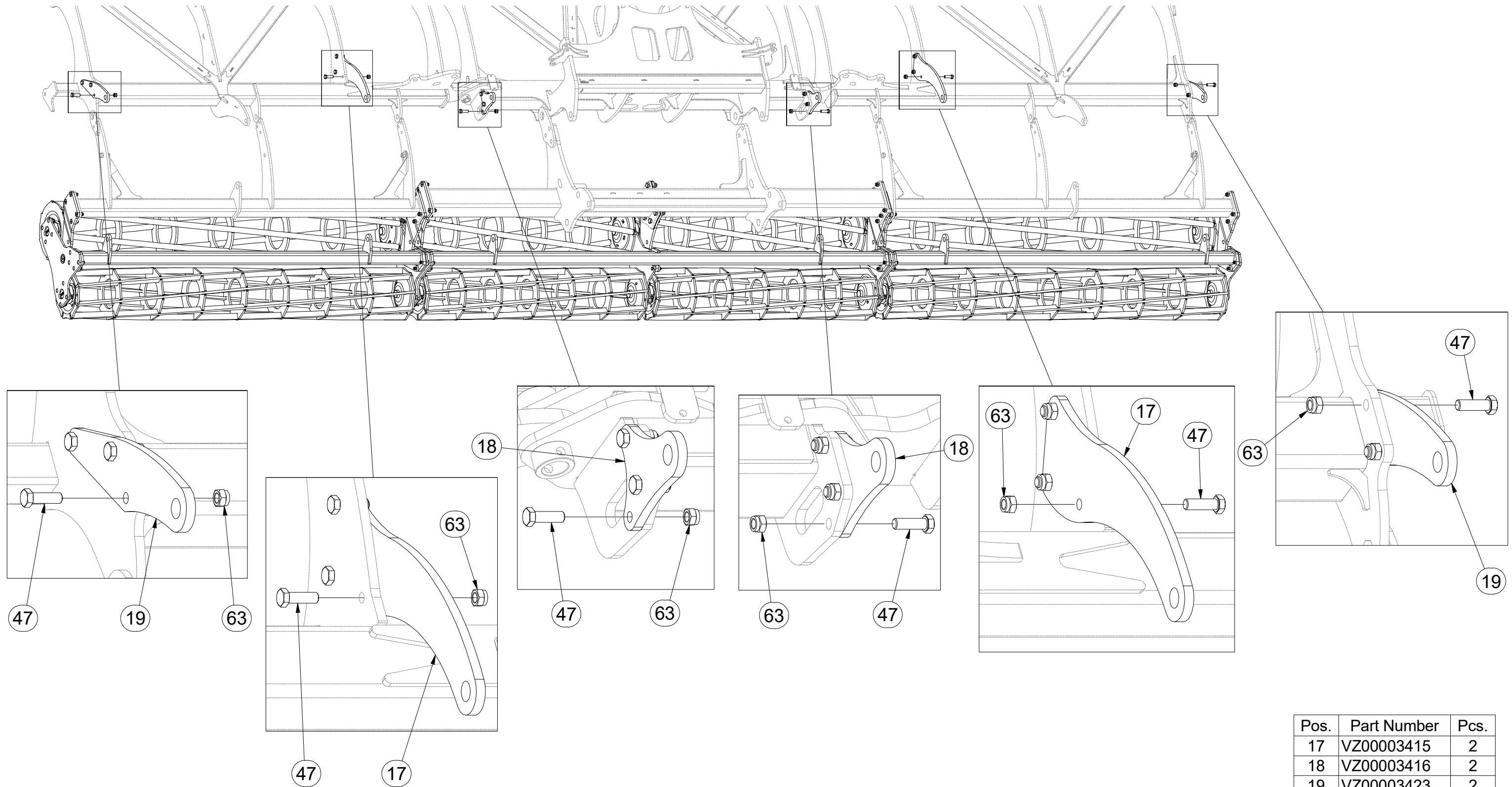

Pos.	Part Number	Pcs.
17	VZ00003415	2
18	VZ00003416	2
19	VZ00003423	2
47	m10849	18
63	m20385	18

- Ⓒ SADA ZADNÍCH VÁLCŮ
- Ⓓ SATZ HINTERE WALZEN
- Ⓕ KIT DE ROULEAUX ARRIÈRE

**VZ00019413**

- Ⓖ SET OF REAR ROLLERS
- Ⓡ КОМПЛЕКТ ЗАДНИХ КАТКОВ
- Ⓟ ZESTAW TYLNYCH WAŁÓW

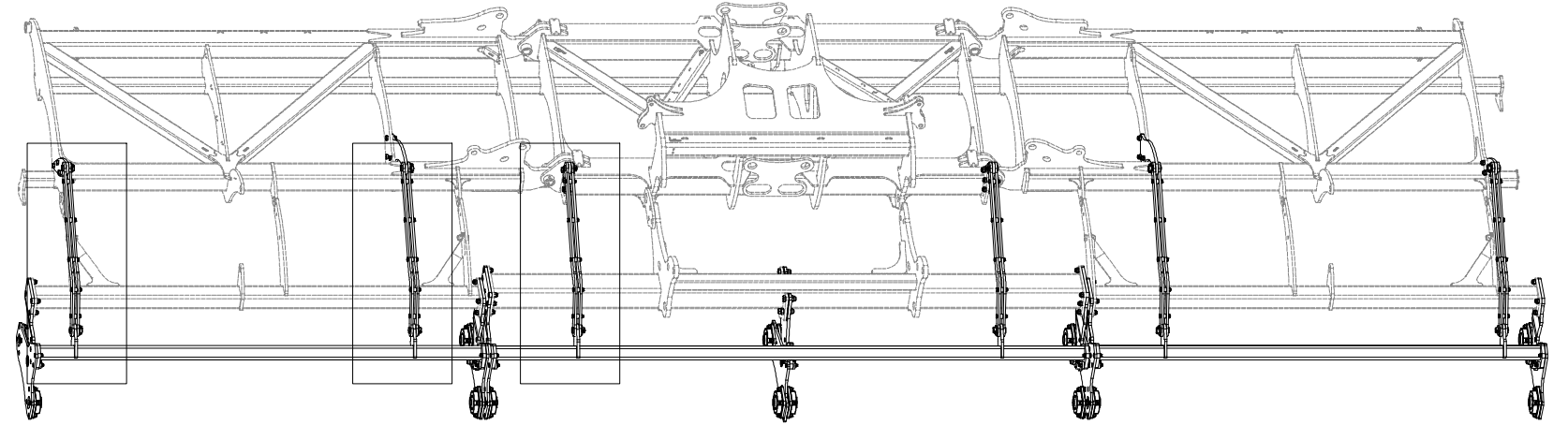
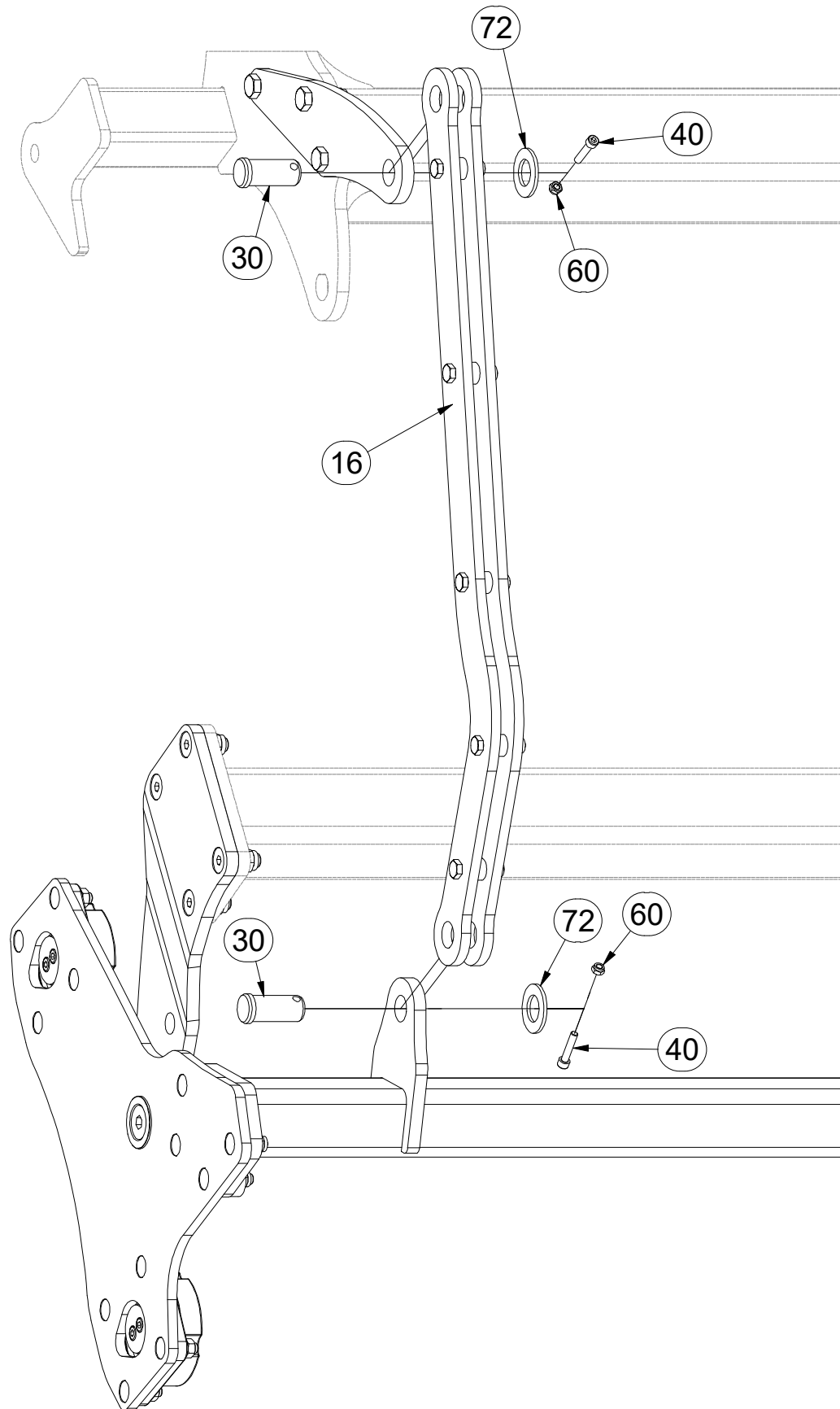

Pos.	Part Number	Pcs.
16	VZ00016554	6
30	4025823	12
40	m13894	12
60	m04503	12
72	m14029	12



- Ⓒ SADA ZADNÍCH VÁLCŮ
- Ⓓ SATZ HINTERE WALZEN
- Ⓕ KIT DE ROULEAUX ARRIÈRE

**VZ00019413**

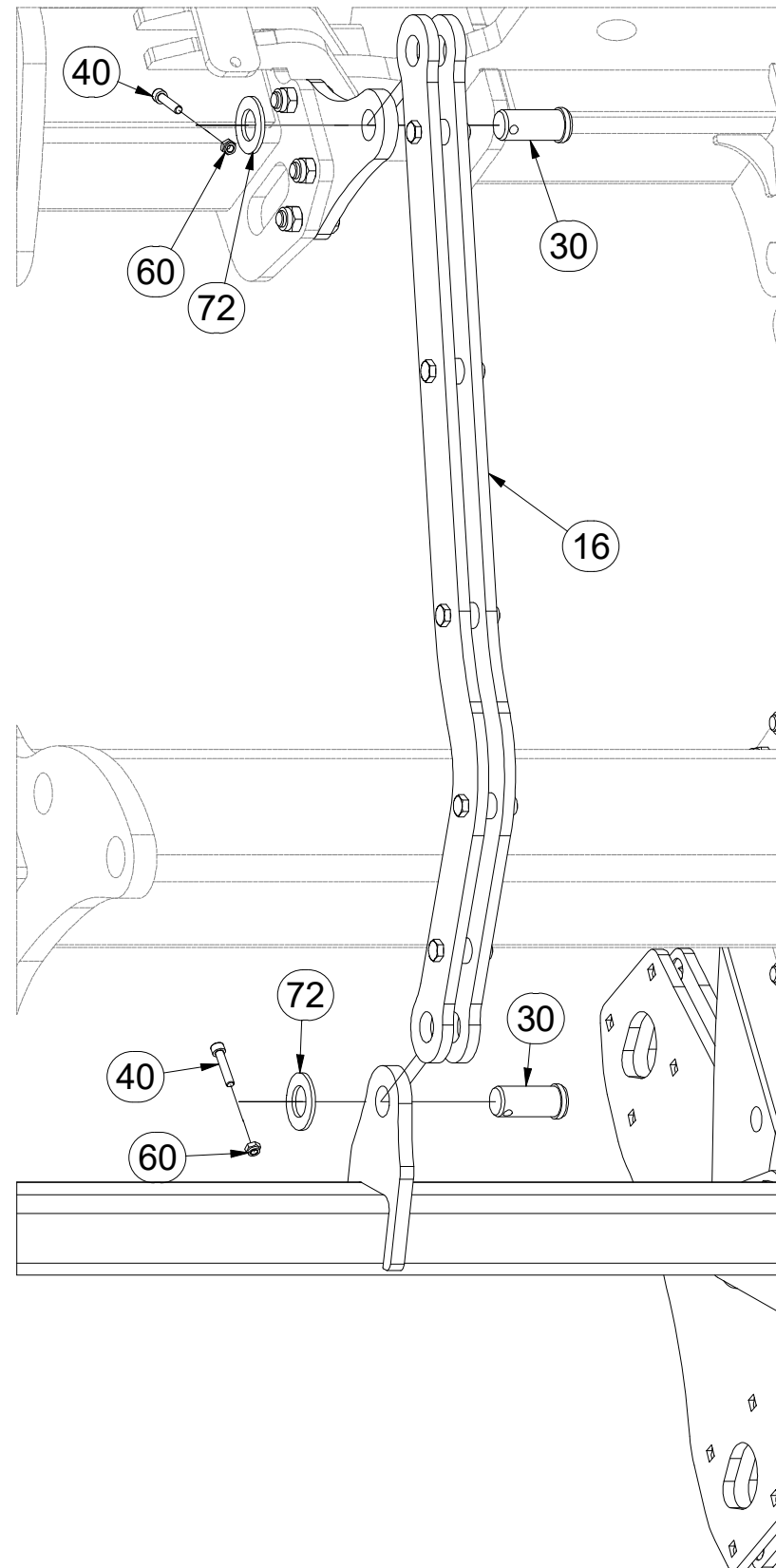

- Ⓖ SET OF REAR ROLLERS
- Ⓡ КОМПЛЕКТ ЗАДНИХ КАТКОВ
- Ⓟ ZESTAW TYLNYCH WAŁÓW

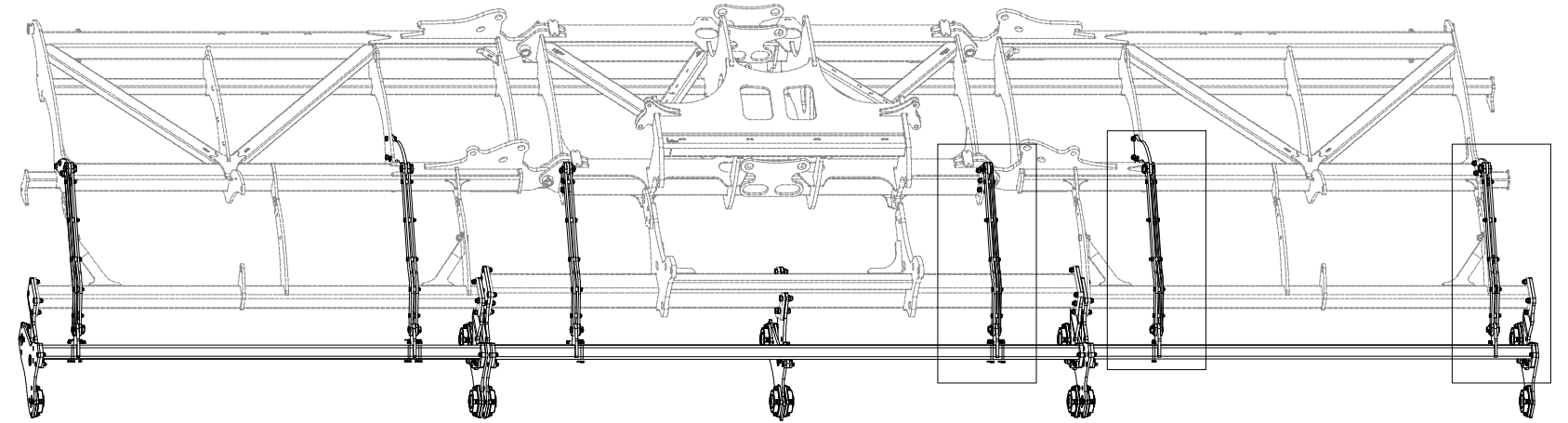

Pos.	Part Number	Pcs.
16	VZ00016554	6
30	4025823	12
40	m13894	12
60	m04503	12
72	m14029	12

ⒸZ TÁHLO

Ⓓ STANGE

Ⓕ TIGE DE TRACTION

**VZ00016554**

ⒼB DRAWBAR

Ⓔ RU ТЯГА

Ⓗ PL PRĘT

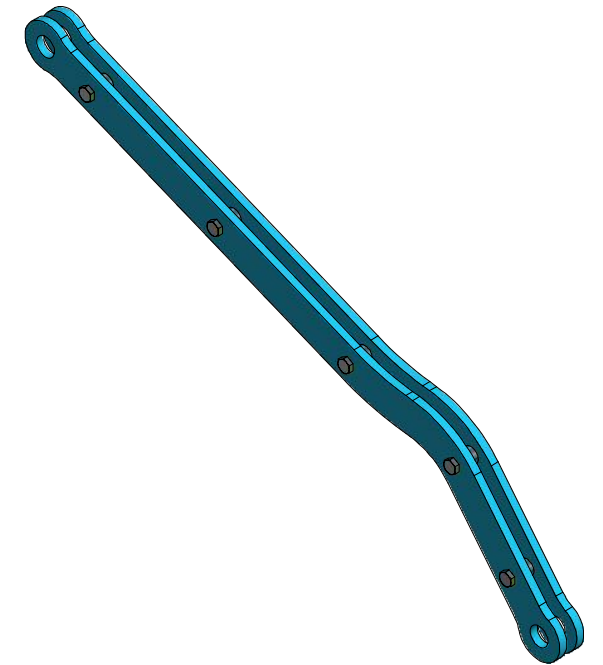
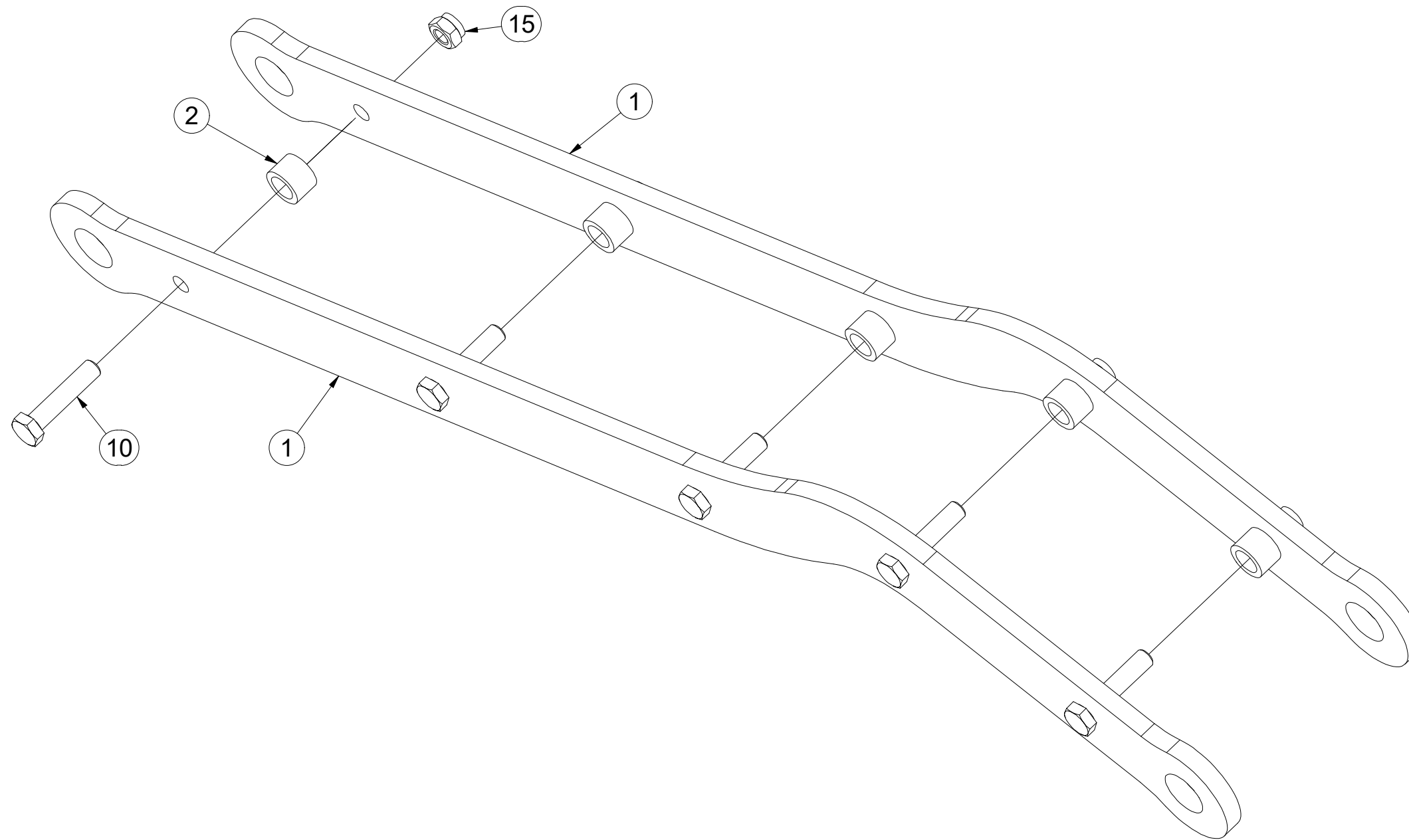

Pos.	Part Number	Pcs.
1	VZ00016555	2
2	4006690	5
10	m04412	5
15	m04301	5

Ⓒ SADA NÁPRAVY

Ⓓ SATZ AUFHÄNGUNG

Ⓕ KIT DE L'ESSIEU

Ⓖ AXLE SET

Ⓡ КОМПЛЕКТ ОСИ КОЛЁС

Ⓢ ZESTAW OSI

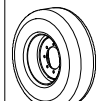

**3012716**

	M18x1,5-265Nm
	350 kPa

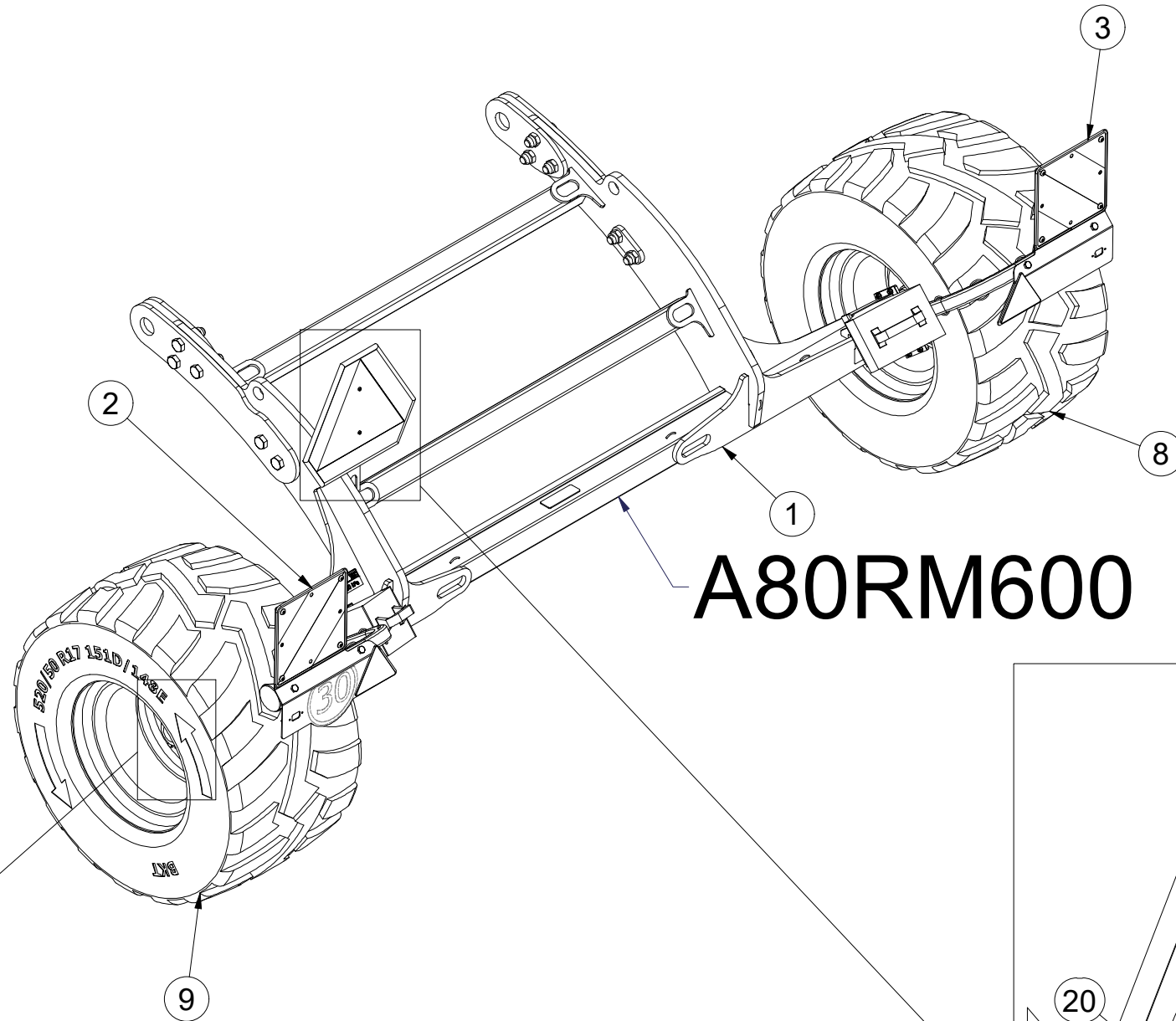

# A80RM600

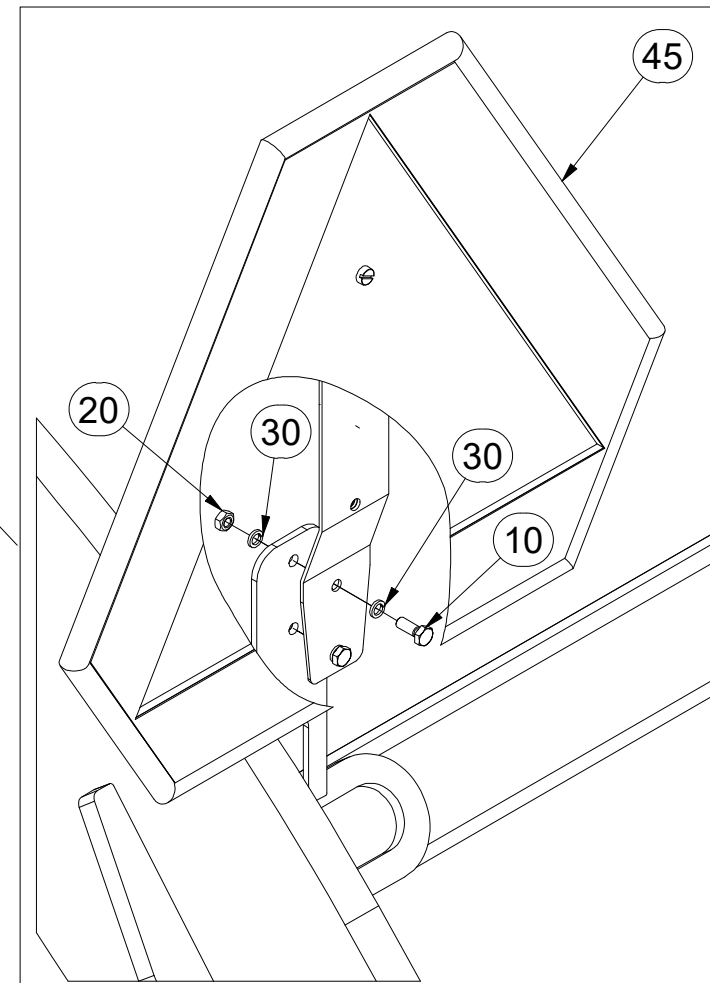
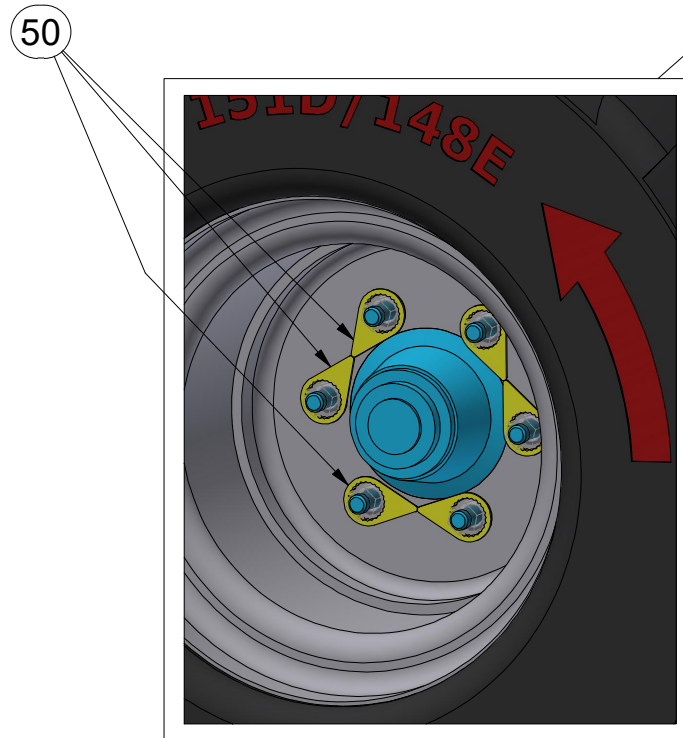

Pos.	Part Number	Pcs.
1	2001271	1
2	3012367	1
3	3012389	1
8	m20283	1
9	m20284	1
10	m01073	2
20	m01295	2
30	m01200	4
45	m05371	1
50	m19659	12

ⒸZ SADA NÁPRAVY

Ⓓ SATZ AUFHÄNGUNG

Ⓕ KIT DE L'ESSIEU

ⒸGB AXLE SET

ⒸRU КОМПЛЕКТ ОСИ КОЛЁС

ⒸPL ZESTAW OSI



**3012716**

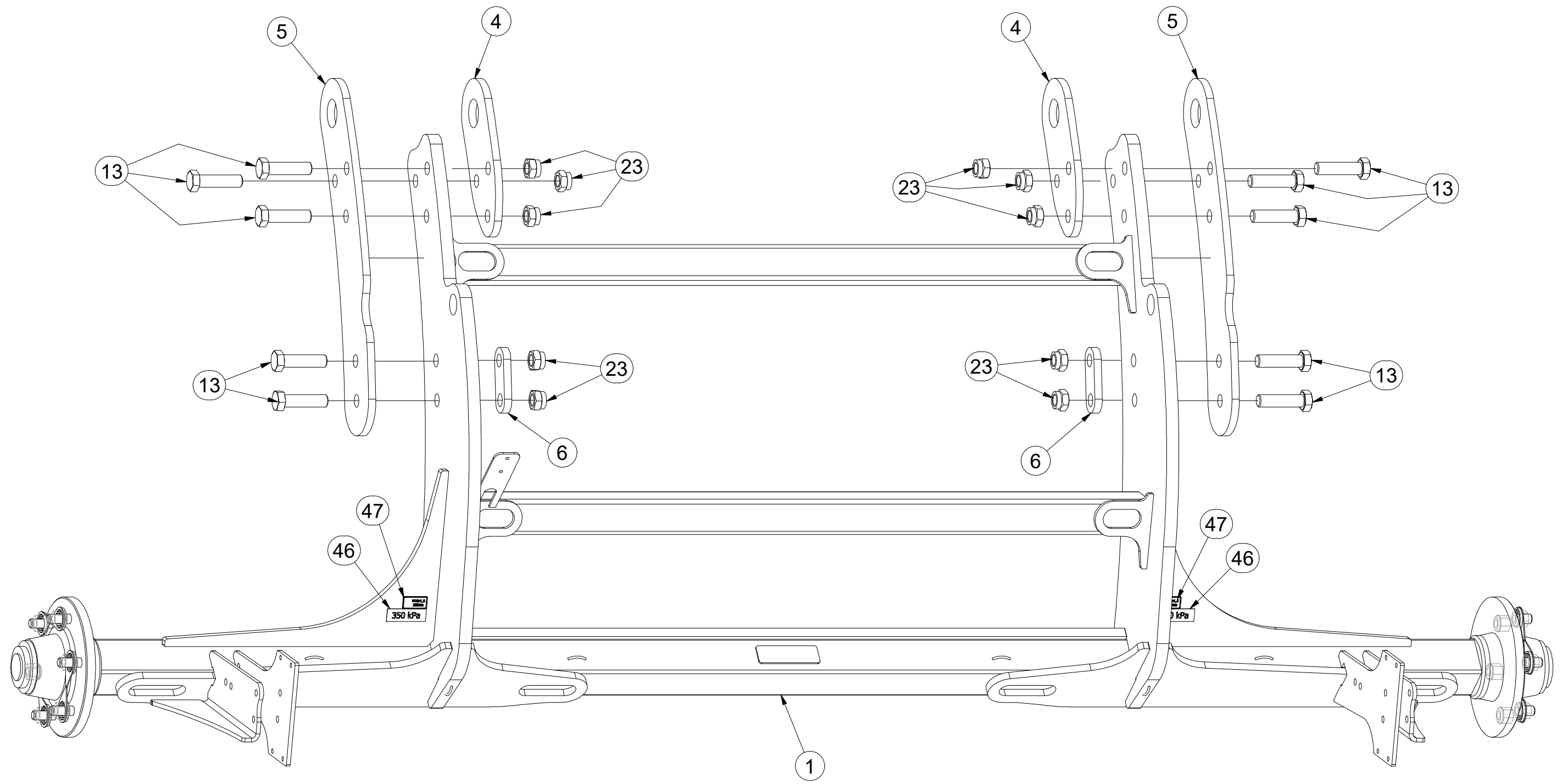

Pos.	Part Number	Pcs.	Pos.	Part Number	Pcs.
1	2001271	1	13	m14495	10
4	4014698	2	23	m07147	10
5	4014700	2	46	m08845	2
6	4019959	2	47	m19732	2

ⒸZ SADA NÁPRAVY

Ⓓ SATZ AUFHÄNGUNG

Ⓕ KIT DE L'ESSIEU

ⒸB AXLE SET

ⒸU КОМПЛЕКТ ОСИ КОЛЁС

ⒸL ZESTAW OSI



**3012716**

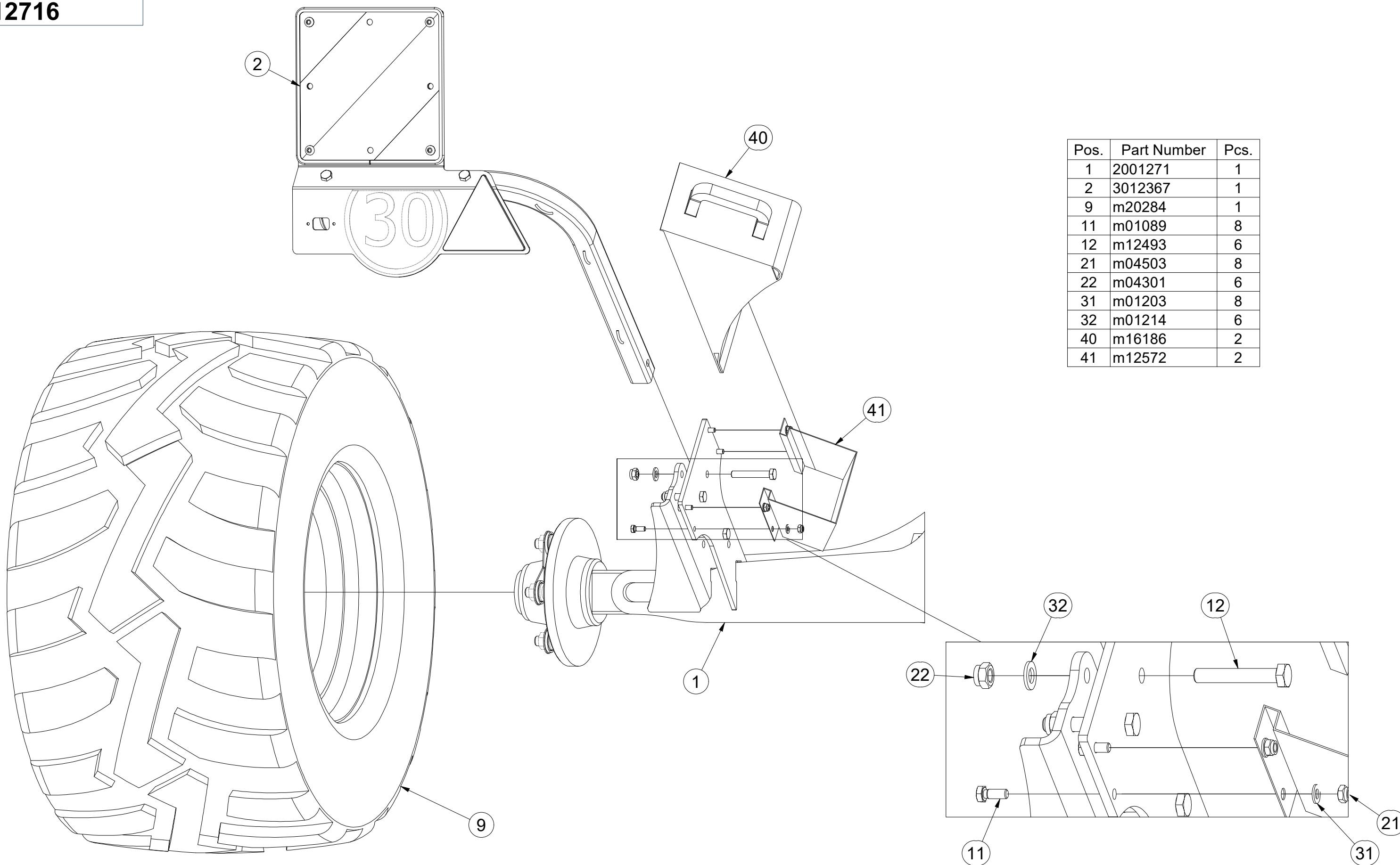

Pos.	Part Number	Pcs.
1	2001271	1
2	3012367	1
9	m20284	1
11	m01089	8
12	m12493	6
21	m04503	8
22	m04301	6
31	m01203	8
32	m01214	6
40	m16186	2
41	m12572	2

Ⓒ SADA NÁPRAVY

Ⓓ SATZ AUFHÄNGUNG

Ⓕ KIT DE L'ESSIEU

Ⓖ AXLE SET

Ⓡ КОМПЛЕКТ ОСИ КОЛЁС

Ⓢ ZESTAW OSI



**3012716**

Pos.	Part Number	Pcs.
1	2001271	1
3	3012389	1
8	m20283	1
11	m01089	8
12	m12493	6
21	m04503	8
22	m04301	6
31	m01203	8
40	m16186	2
41	m12572	2

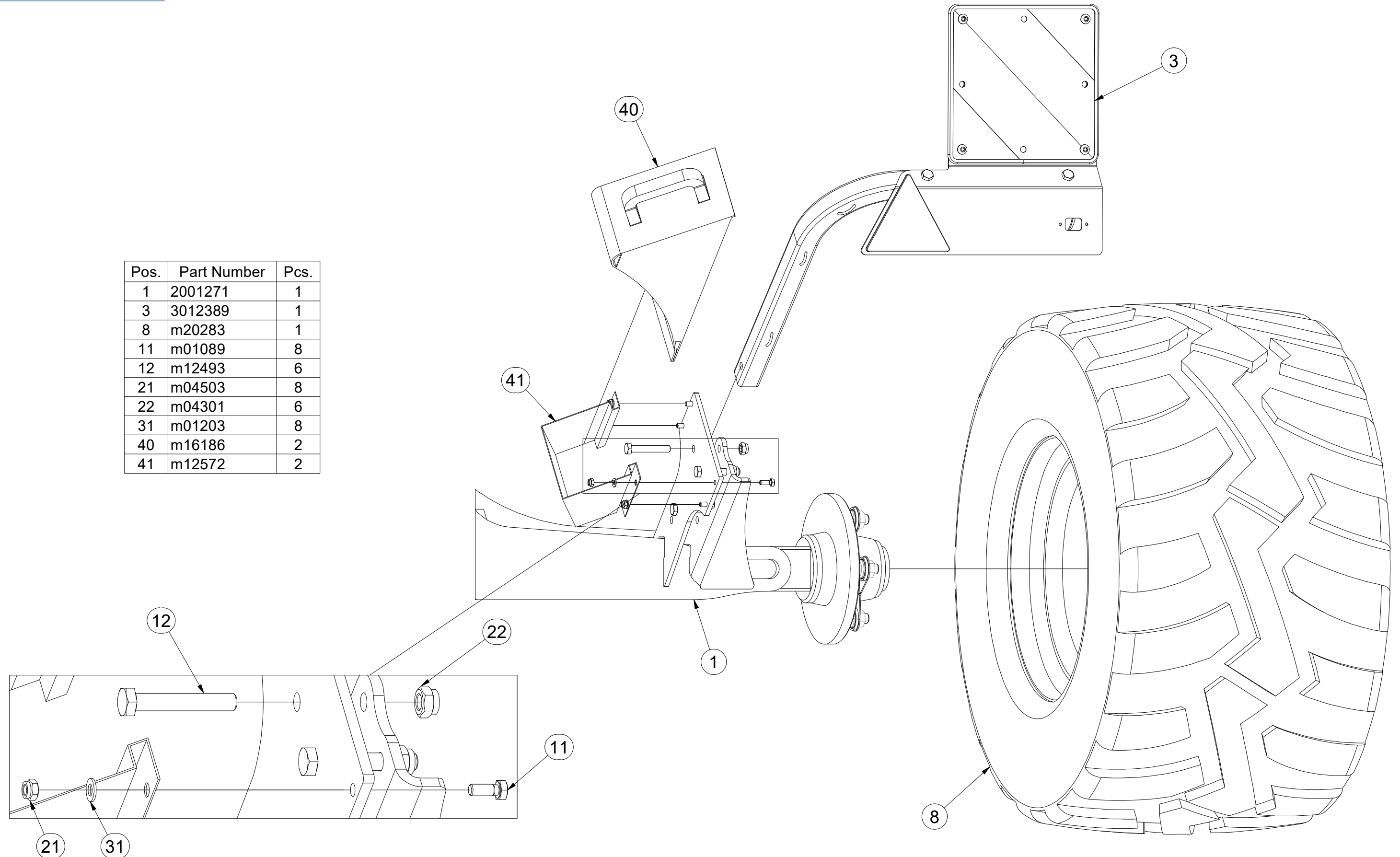

Ⓒ NÁPRAVA

Ⓓ ACHSE

Ⓕ ESSIEU

Ⓒ AXLE

Ⓓ OCB

Ⓕ OS



**A80RM600**

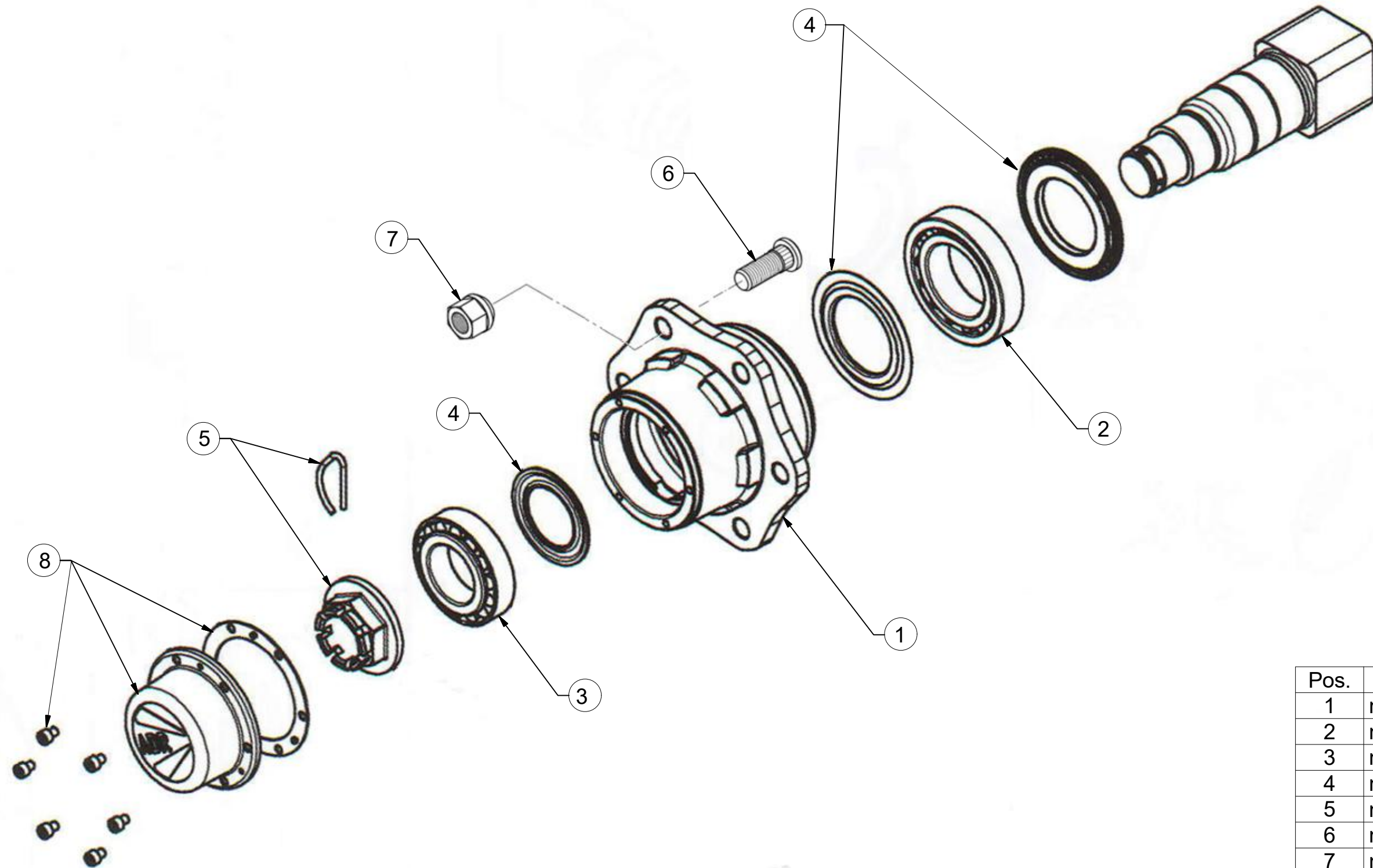

Pos.	Part Number	Pcs.
1	m12567	2
2	m07153	2
3	m07154	2
4	m12565	2
5	m08168	2
6	m08148	12
7	m08163	12
8	m12566	2

ⒸZ TERČ ZADNÍ LEVÝ

Ⓓ SCHILD, HINTERES, LINKES

Ⓕ CIBLE ARRIÈRE GAUCHE

**3012367**

ⒸB LEFT REAR DISC

Ⓔ ЩИТОК ЗАДНИЙ ЛЕВЫЙ

Ⓗ TARCZA TYLNA LEWA

**Farmet**

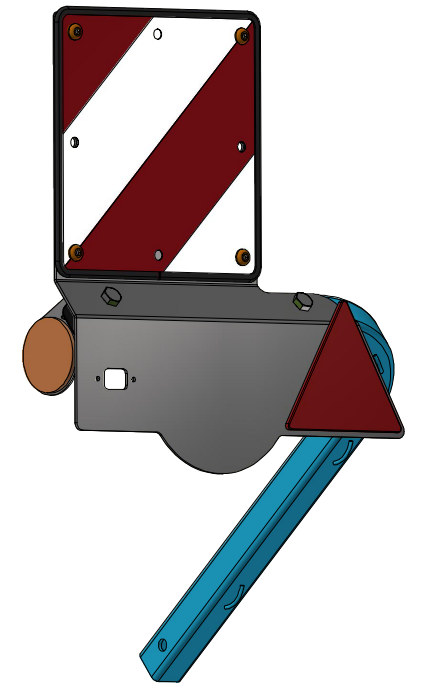
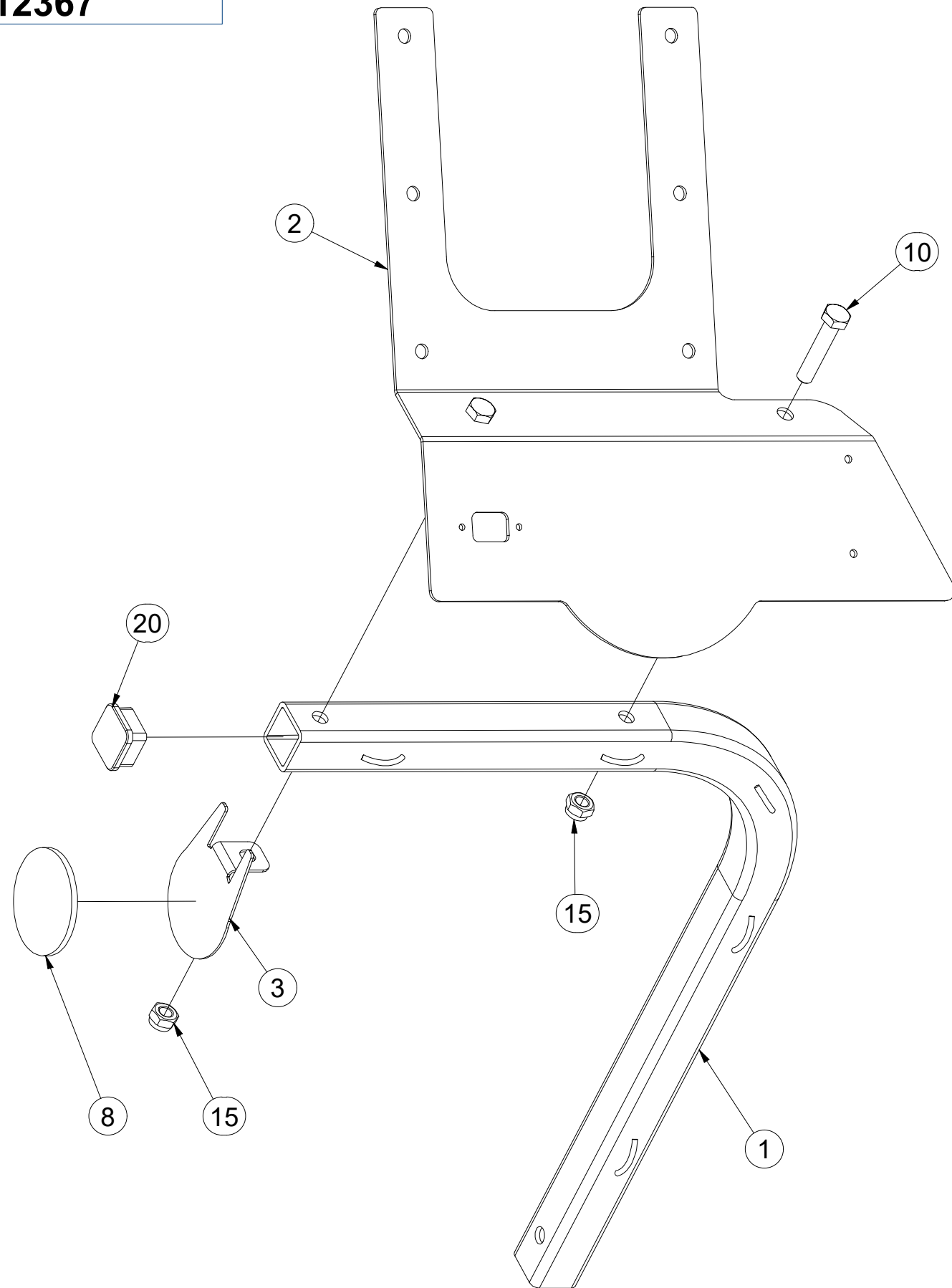

Pos.	Part Number	Pcs.
1	3012364	1
2	3012365	1
3	4024926	1
8	m02579	1
10	m01131	2
15	m04301	2
20	m12689	1



ⒸZ TERČ ZADNÍ LEVÝ

Ⓓ SCHILD, HINTERES, LINKES

Ⓕ CIBLE ARRIÈRE GAUCHE

ⒼB LEFT REAR DISC

ⒶU ЩИТОК ЗАДНИЙ ЛЕВЫЙ

ⒶL TARCZA TYLNA LEWA



**3012367**

Pos.	Part Number	Pcs.
5	m18855	1
6	9005707	1
7	m02497	1
11	m16637	4
16	m03775	4
25	m01209	4

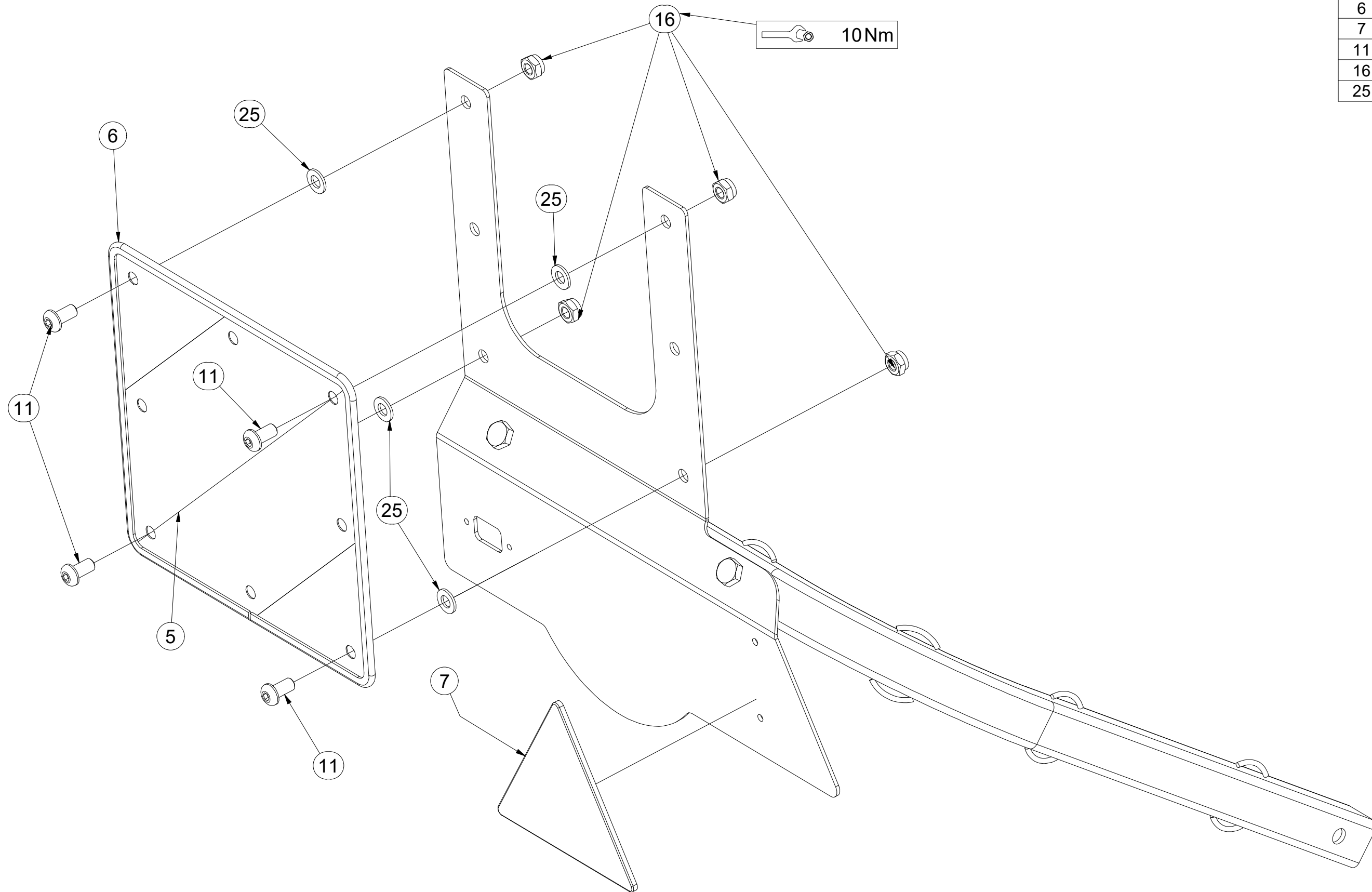

ⒸZ TERČ ZADNÍ PRAVÝ

Ⓓ SCHILD, HINTERES, RECHTES

Ⓕ CIBLE ARRIÈRE DROITE

**3012389**

ⒼB RIGHT REAR DISC

ⒺЩИТОК ЗАДНИЙ ПРАВЫЙ

ⒽL TARCZA TYLNA PRAWA

**Farmet**

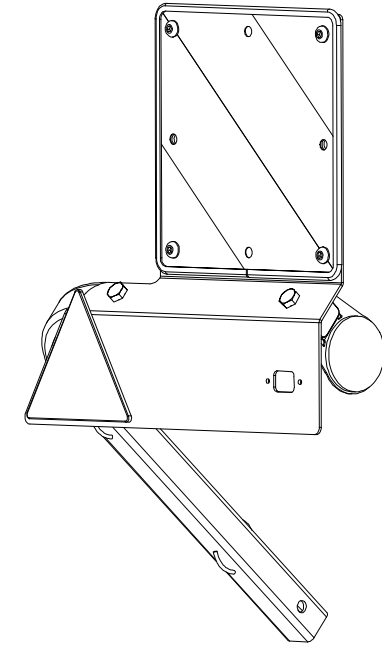
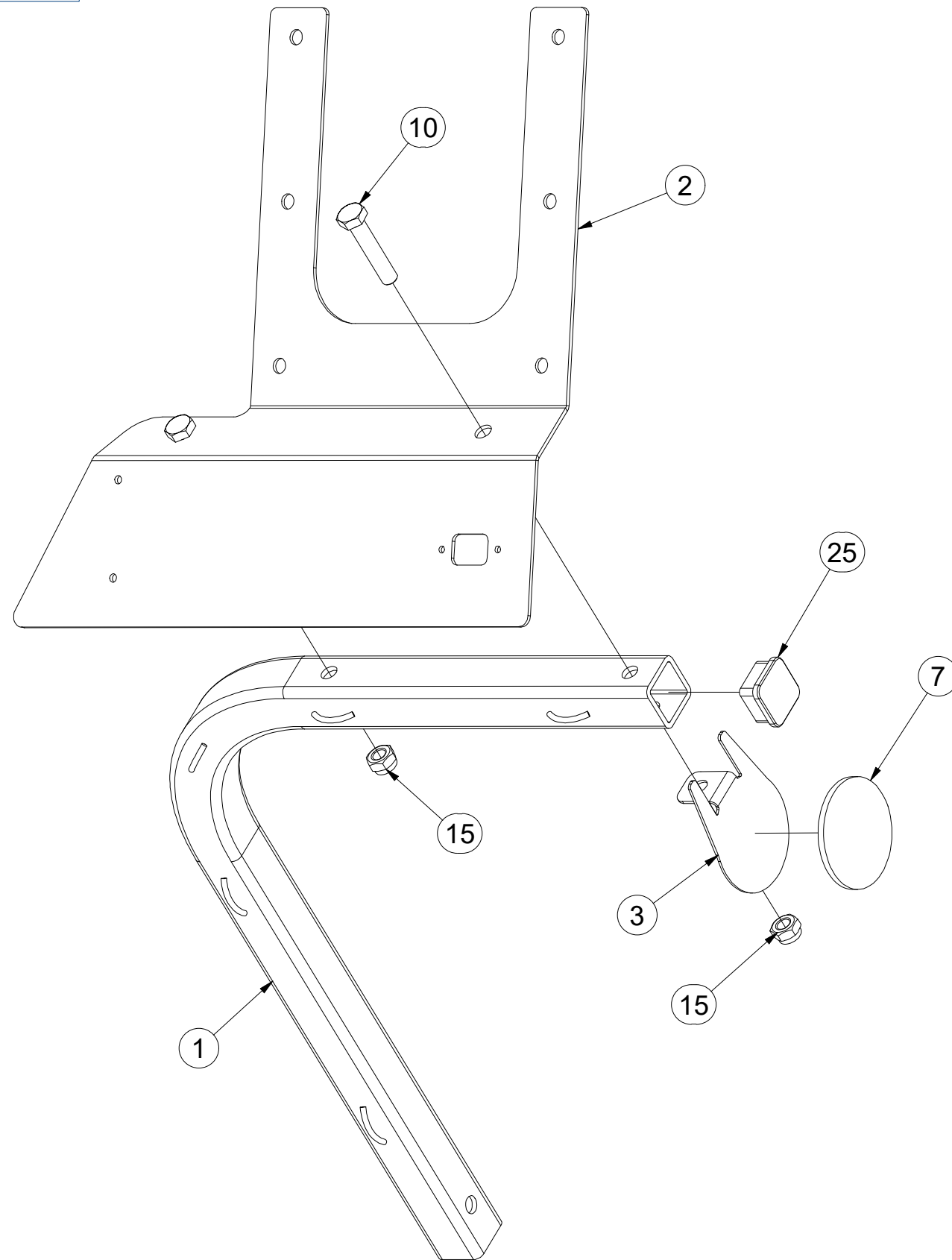

Pos.	Part Number	Pcs.
1	3012364	1
2	3012390	1
3	4024926	1
7	m02579	1
10	m01131	2
15	m04301	2
25	m12689	1

ⒸZ TERČ ZADNÍ PRAVÝ

Ⓓ SCHILD, HINTERES, RECHTES

Ⓕ CIBLE ARRIÈRE DROITE

ⒼB RIGHT REAR DISC

ⒺЩИТОК ЗАДНИЙ ПРАВЫЙ

ⒽL TARCZA TYLNA PRAWA

**Farmet**

**3012389**

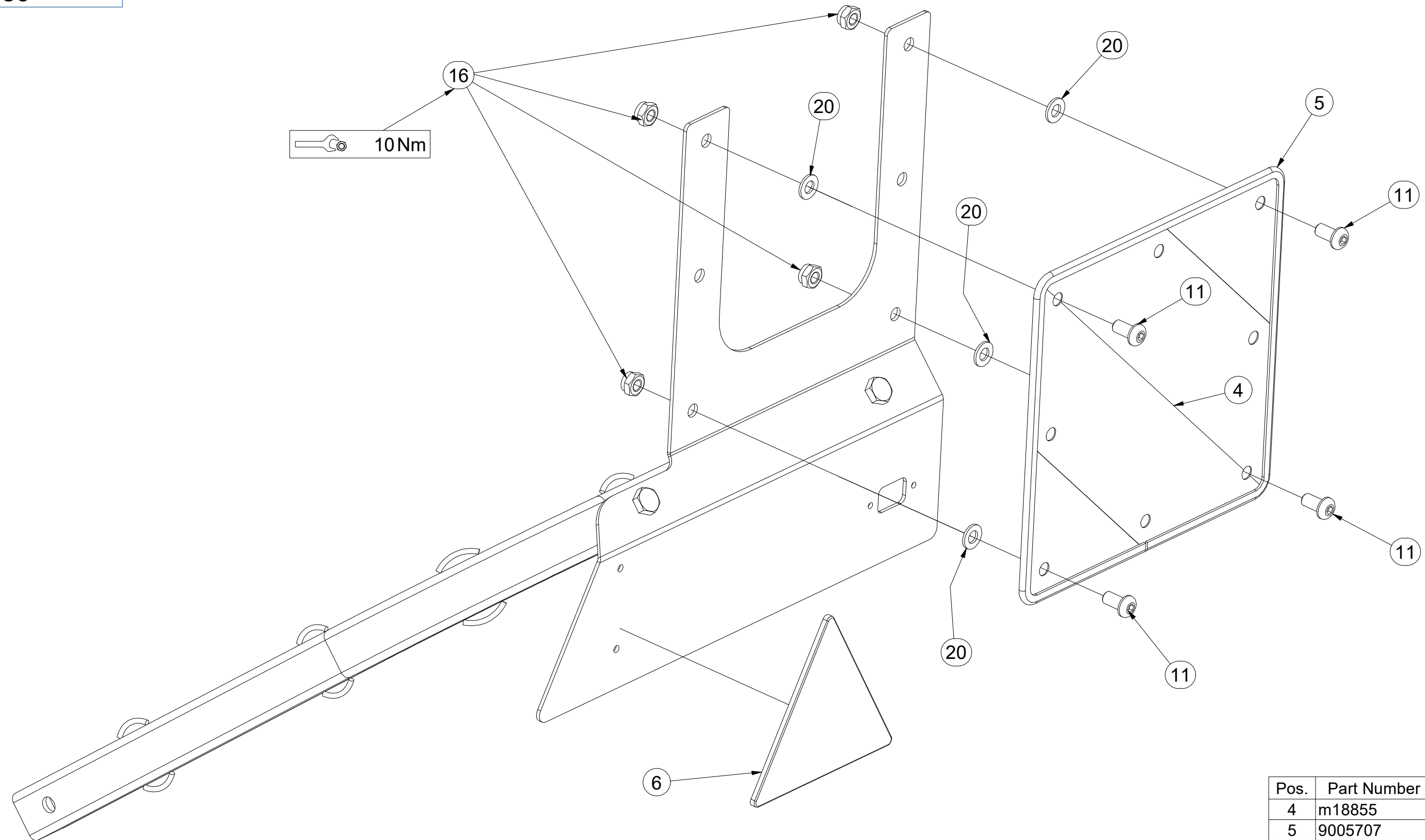

Pos.	Part Number	Pcs.
4	m18855	1
5	9005707	1
6	m02497	1
11	m16637	4
16	m03775	4
20	m01209	4

ⒸZ HYDRAULIKA STROJE

Ⓓ HYDRAULIK DER MASCHINE

Ⓕ HYDRAULIQUE DE LA MACHINE

ⒸB MACHINE HYDRAULICS

ⒸU ГИДРАВЛИКА МАШИНЫ

ⒸL HYDRAULIKA MASZYN



**VZ00020548**

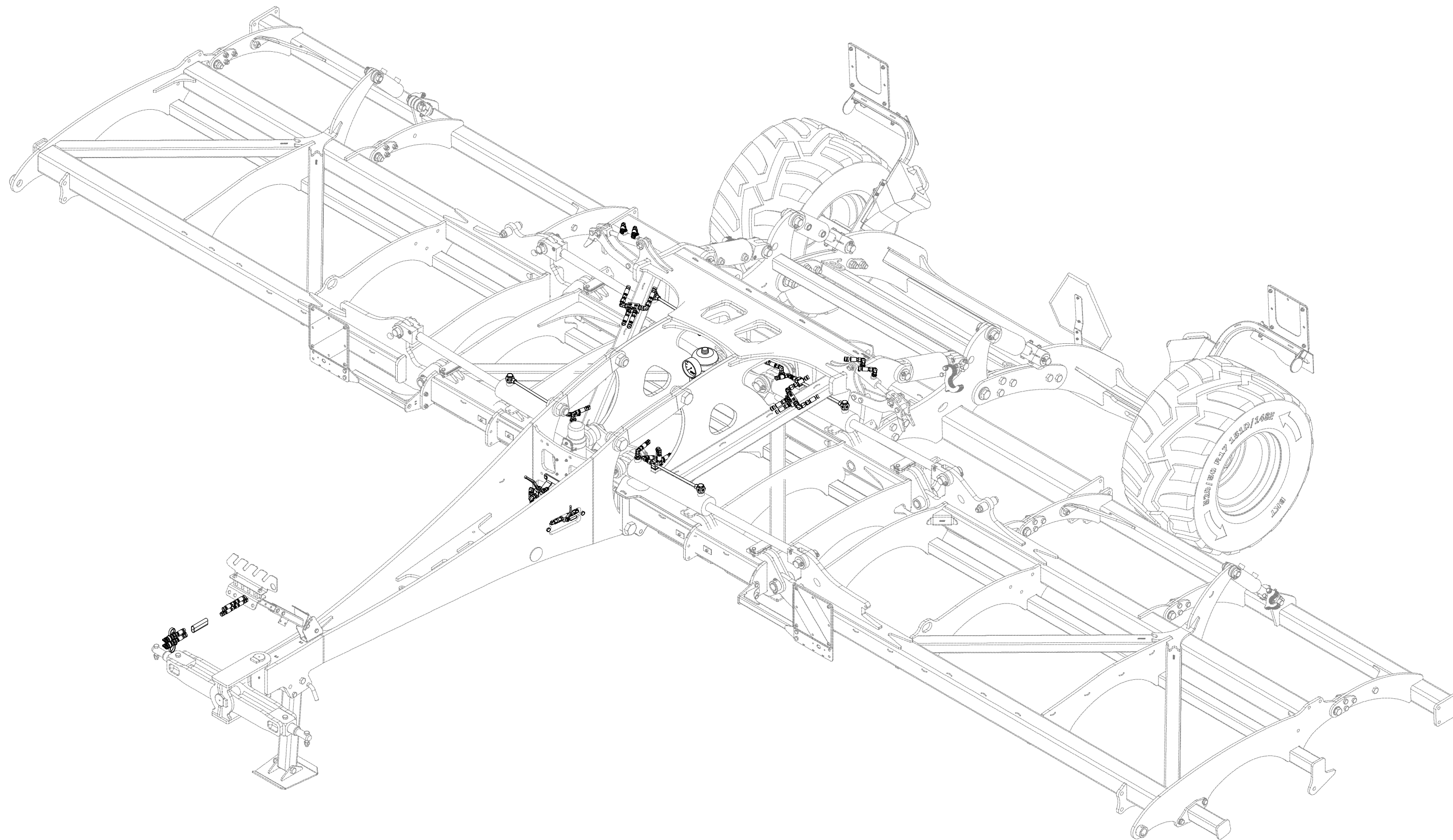

**VZ00020548**

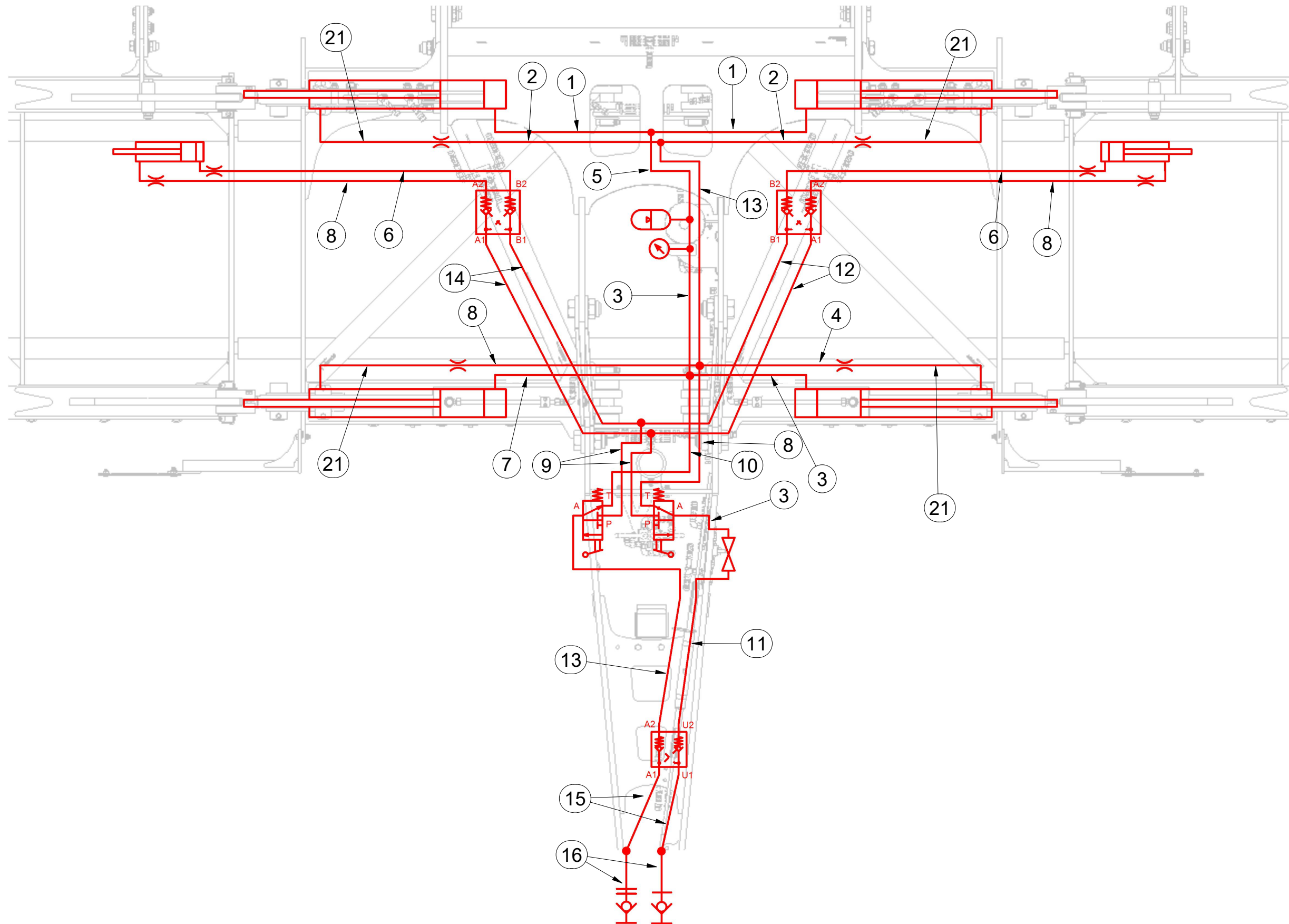

Pos.	Part Number	Pcs.
1	m18193	2
2	m07363	2
3	m09627	3
4	m11000	1
5	m11126	1
6	m04827	2
7	m09628	1
8	m04761	4
9	m09629	2
10	m07645	1
11	m07646	1
12	m07364	2
13	m03951	2
14	m05210	2
15	m07648	2
16	m11696	2
21	m20005	4
50	m10781	4
51	m12060	4

ⒸZ HYDRAULIKA STROJE

Ⓓ HYDRAULIK DER MASCHINE

Ⓕ HYDRAULIQUE DE LA MACHINE

ⒼB MACHINE HYDRAULICS

Ⓔ RU ГИДРАВЛИКА МАШИНЫ

Ⓗ PL HYDRAULIKA MASZYN



**VZ00020548**

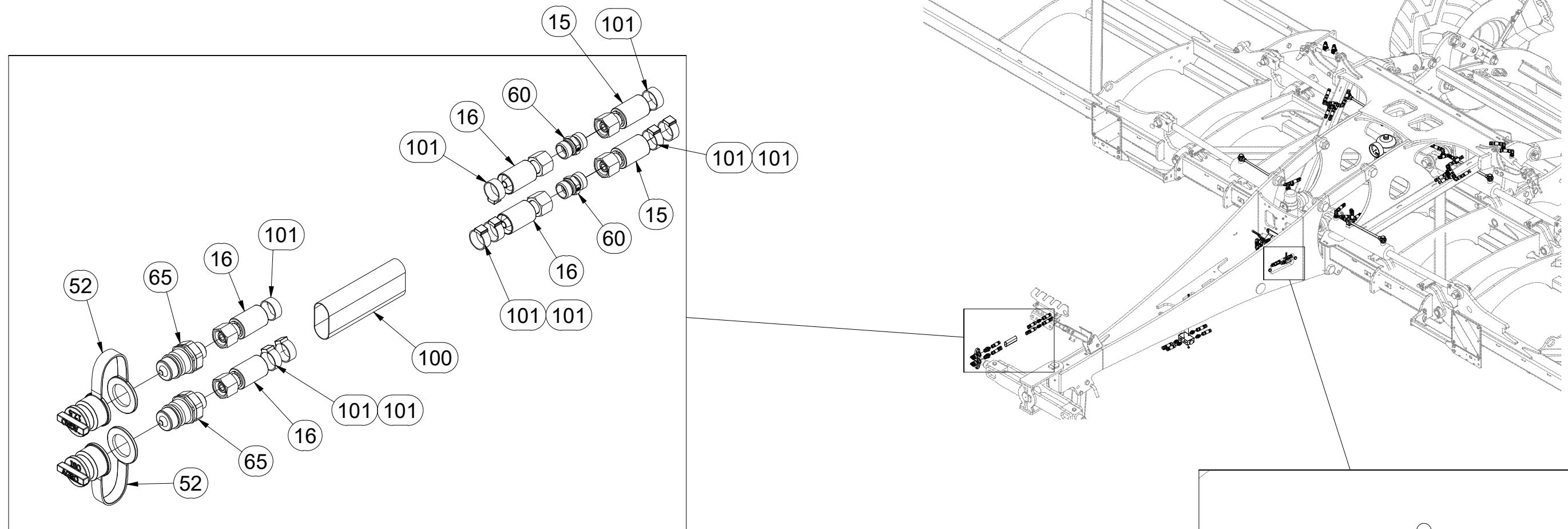

Pos.	Part Number	Pcs.
3	m09627	3
11	m07646	1
15	m07648	2
16	m11696	2
35	m04623	1
48	m22305	2
52	m04022	2
57	m06803	24
59	m08391	2
60	m03213	2
65	m03849	2
75	4025719	1
85	m03926	2
92	m04301	2
100	m11183	1
101	m11294	92

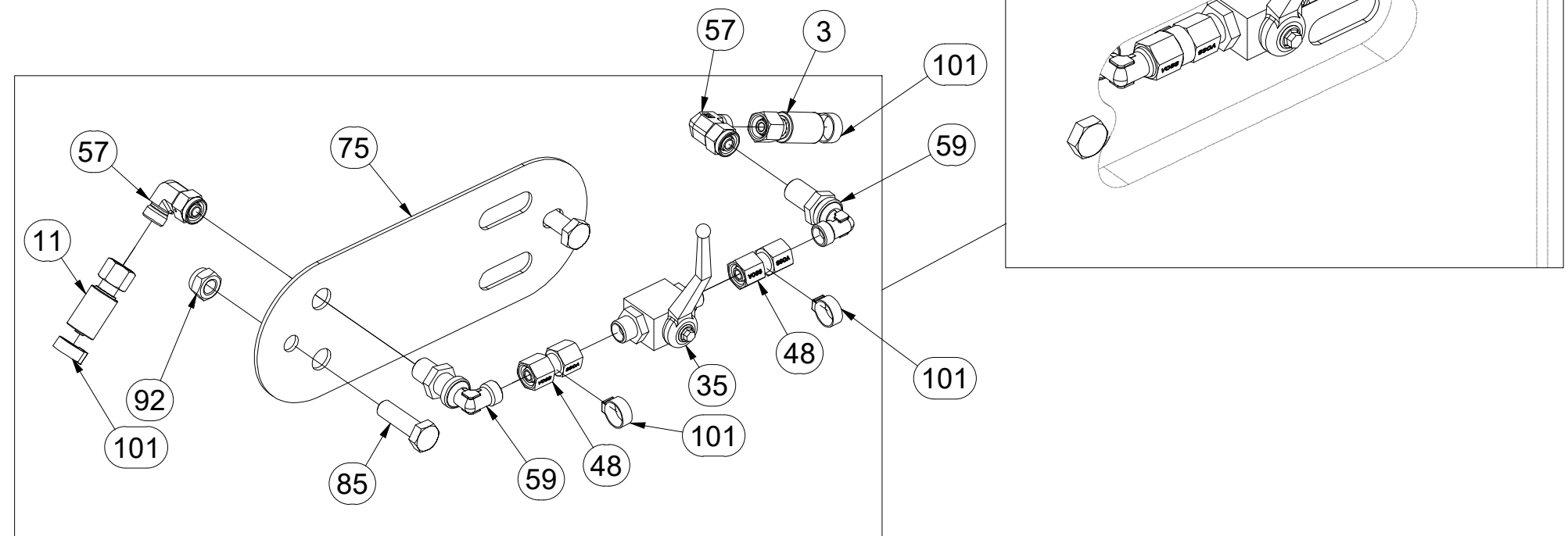

Ⓒ HYDRAULIKA STROJE

Ⓓ HYDRAULIK DER MASCHINE

Ⓕ HYDRAULIQUE DE LA MACHINE

Ⓖ MACHINE HYDRAULICS

Ⓡ ГИДРАВЛИКА МАШИНЫ

Ⓟ HYDRAULIKA MASZYN



**VZ00020548**

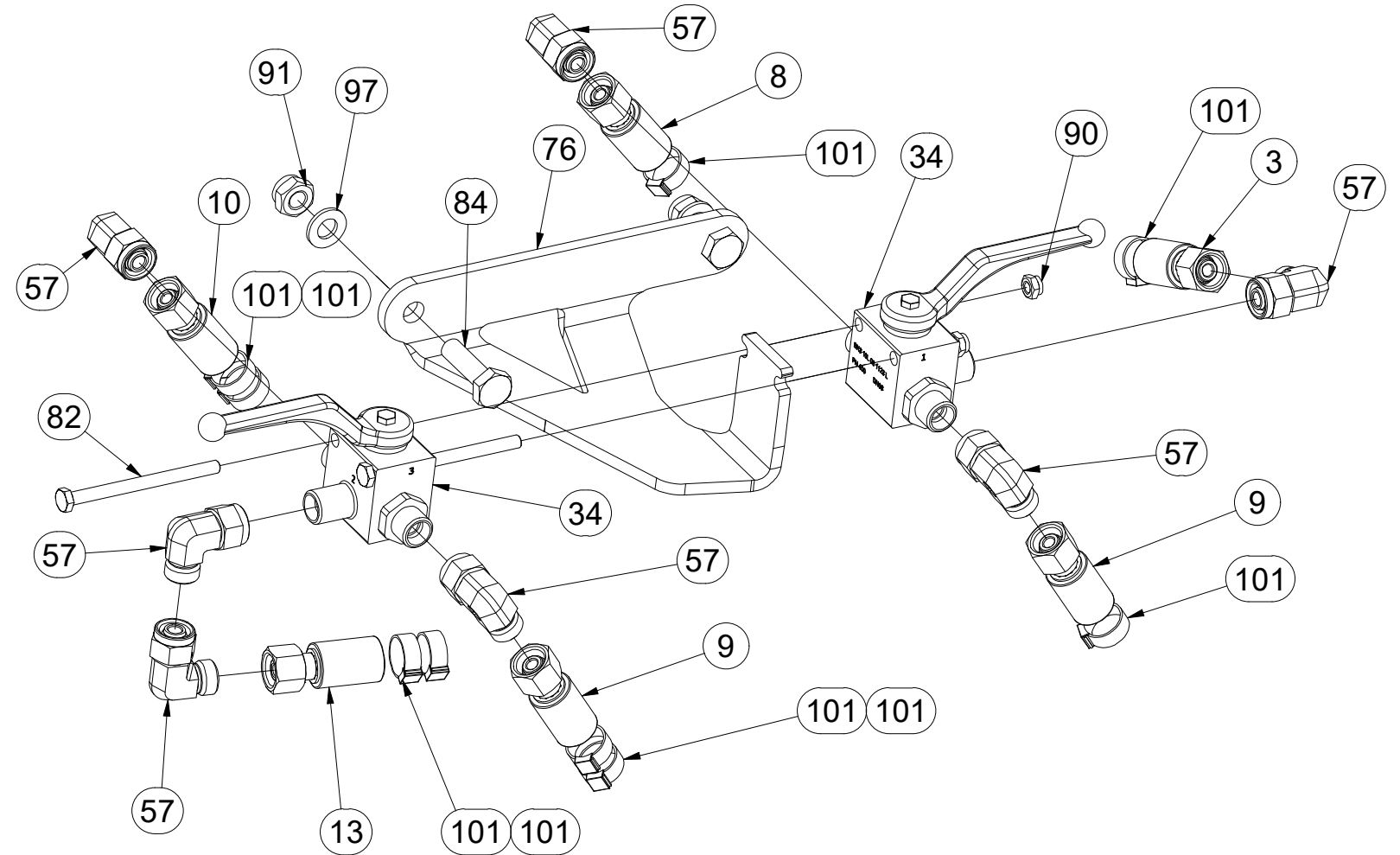
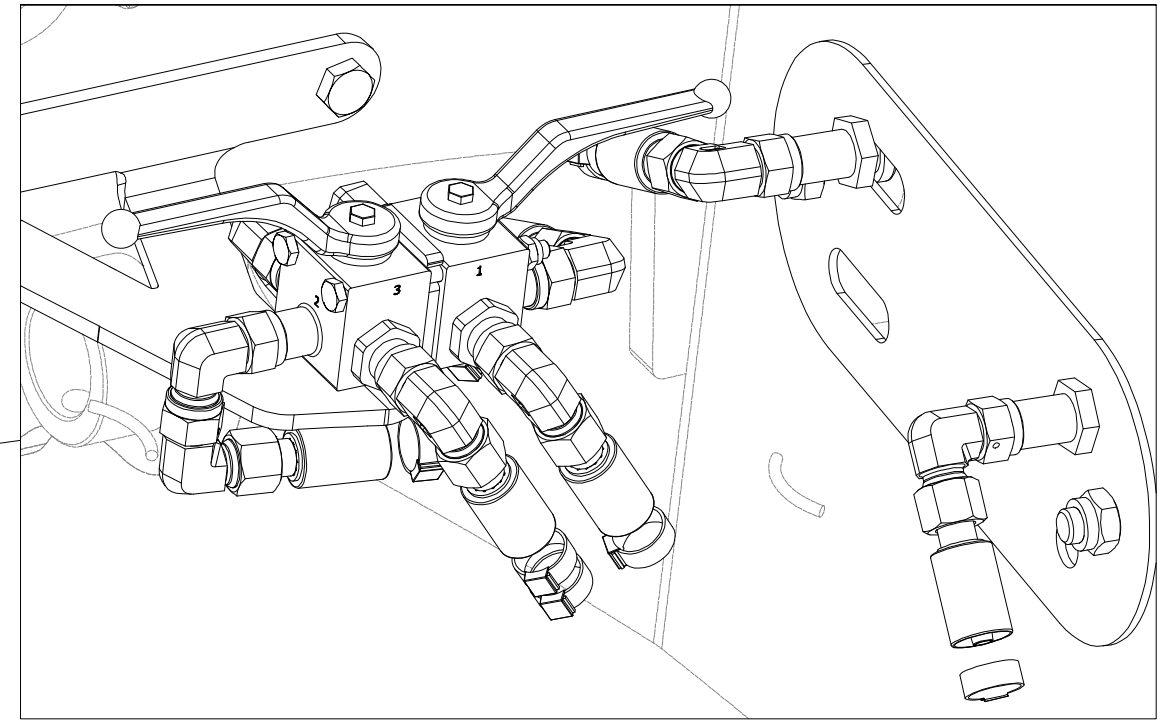
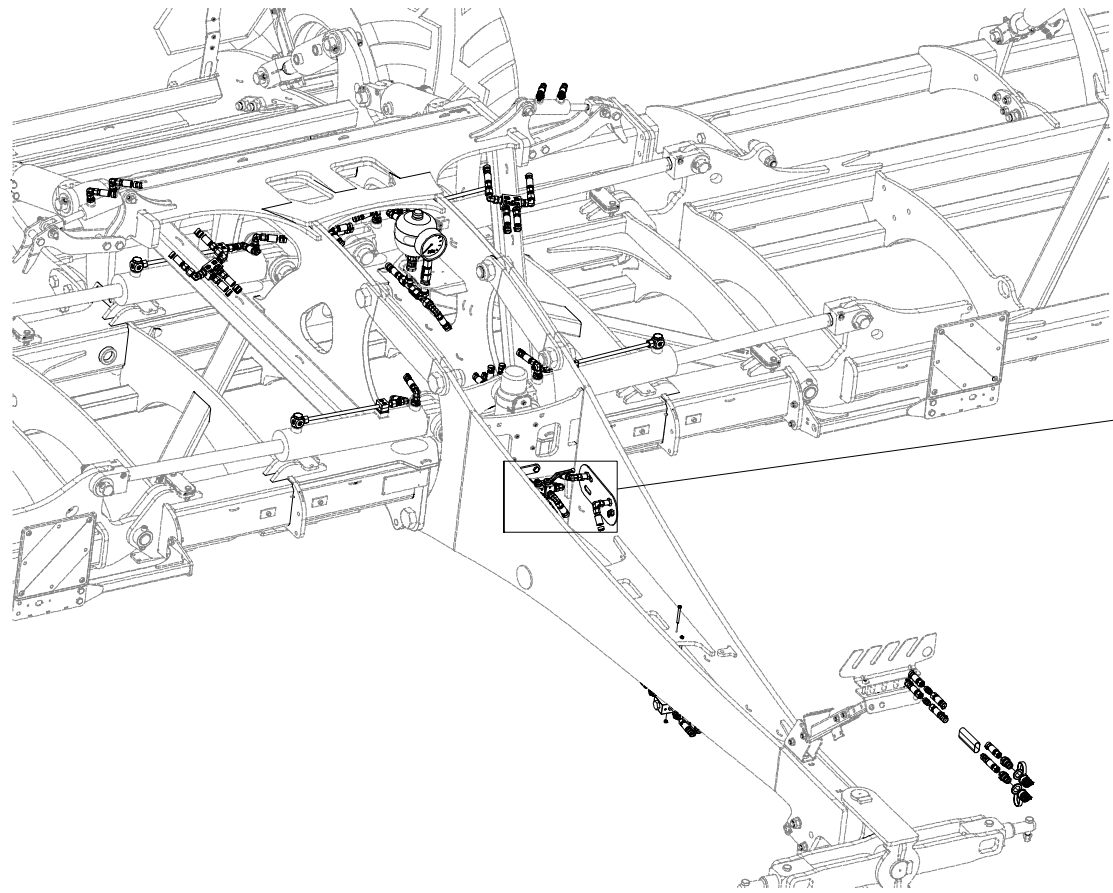

Pos.	Part Number	Pcs.
3	m09627	3
8	m04761	4
9	m09629	2
10	m07645	1
13	m03951	2
34	m08390	2
57	m06803	24
76	VZ00003409	1
82	m17098	2
84	m04613	2
90	m05560	4
91	m03775	2
97	m01209	2
101	m11294	92

ⒸZ HYDRAULIKA STROJE

Ⓓ HYDRAULIK DER MASCHINE

Ⓕ HYDRAULIQUE DE LA MACHINE

ⒼB MACHINE HYDRAULICS

Ⓔ RU ГИДРАВЛИКА МАШИНЫ

Ⓗ PL HYDRAULIKA MASZYN



**VZ00020548**

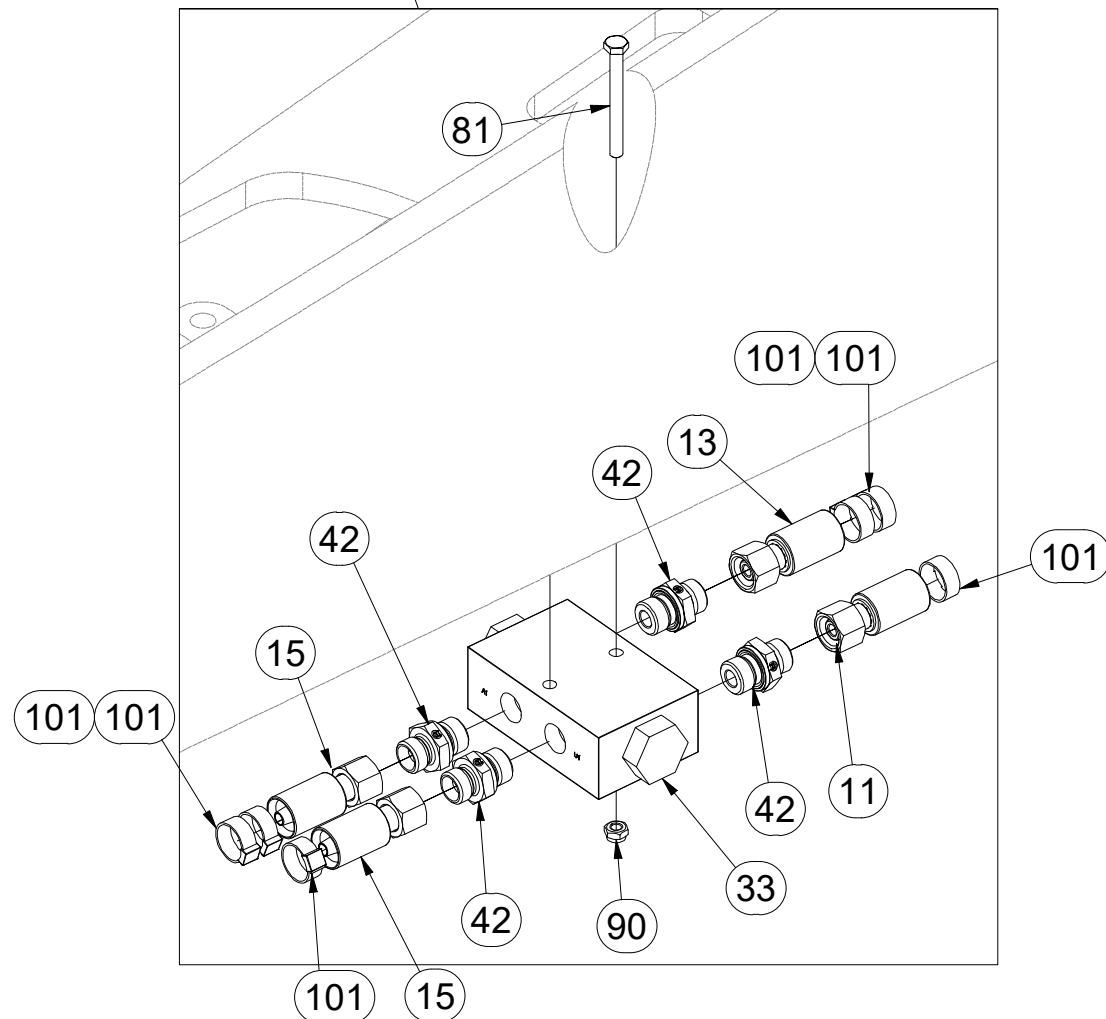
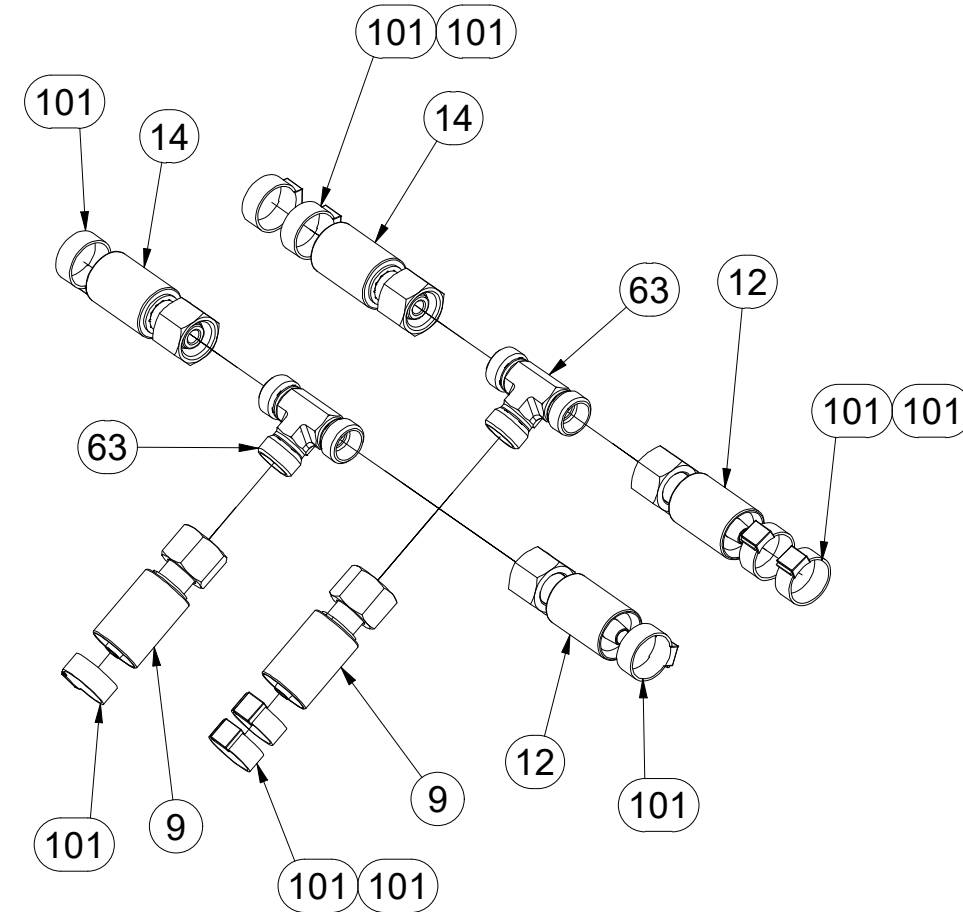
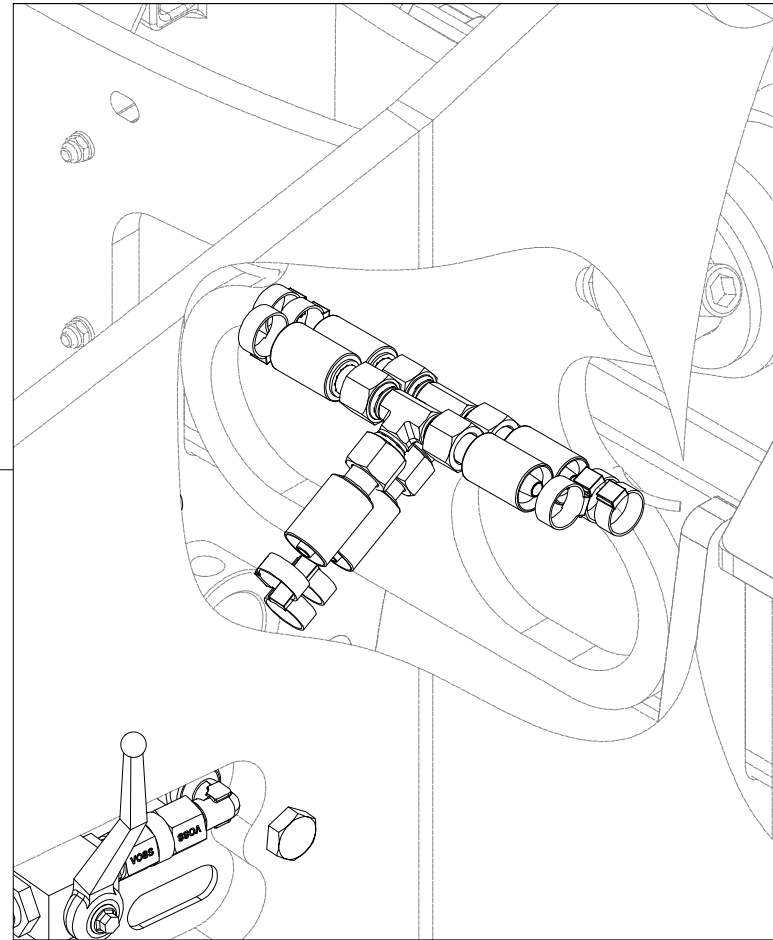
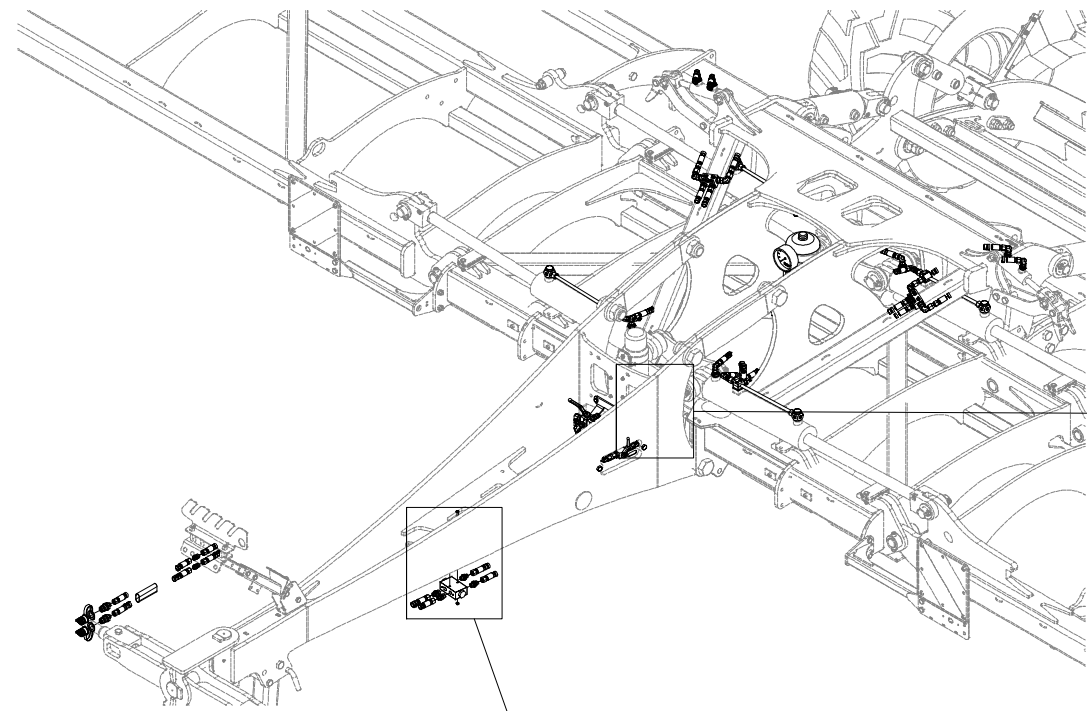

Pos.	Part Number	Pcs.
9	m09629	2
11	m07646	1
12	m07364	2
13	m03951	2
14	m05210	2
15	m07648	2
33	m09911	1
42	m06528	8
63	m03889	4
81	m04843	2
90	m05560	4
101	m11294	92



ⒸZ HYDRAULIKA STROJE

Ⓓ HYDRAULIK DER MASCHINE

Ⓕ HYDRAULIQUE DE LA MACHINE

ⒸB MACHINE HYDRAULICS

ⒸR ГИДРАВЛИКА МАШИНЫ

ⒸL HYDRAULIKA MASZYN



**VZ00020548**

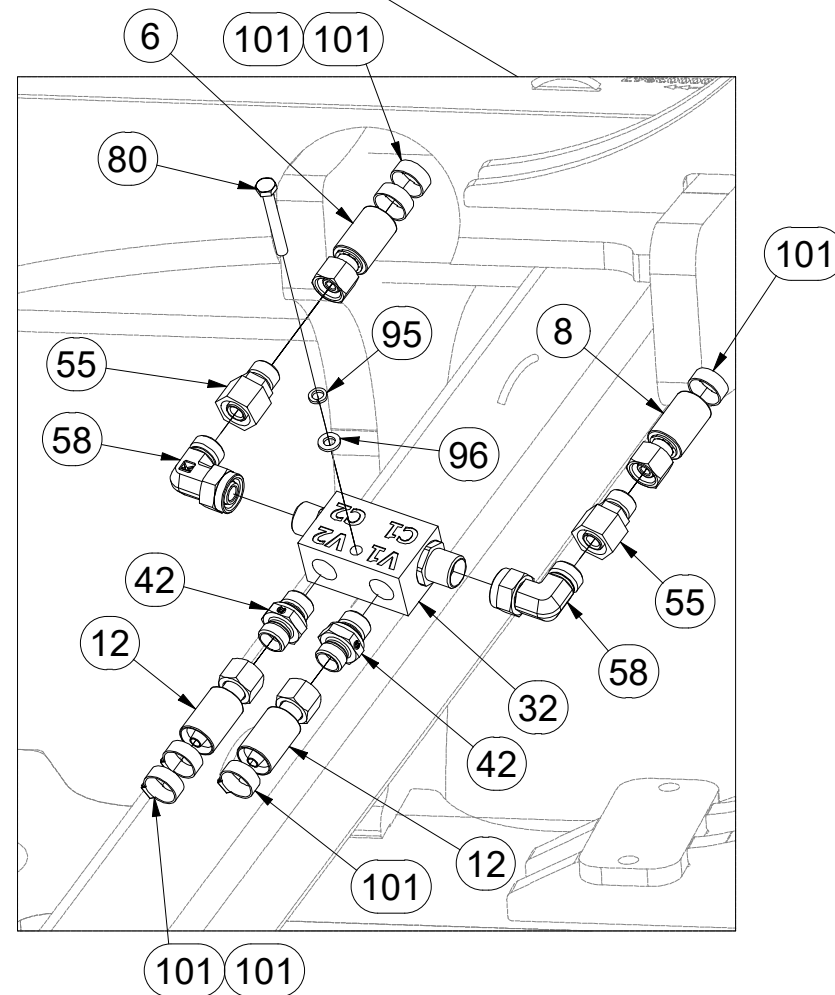
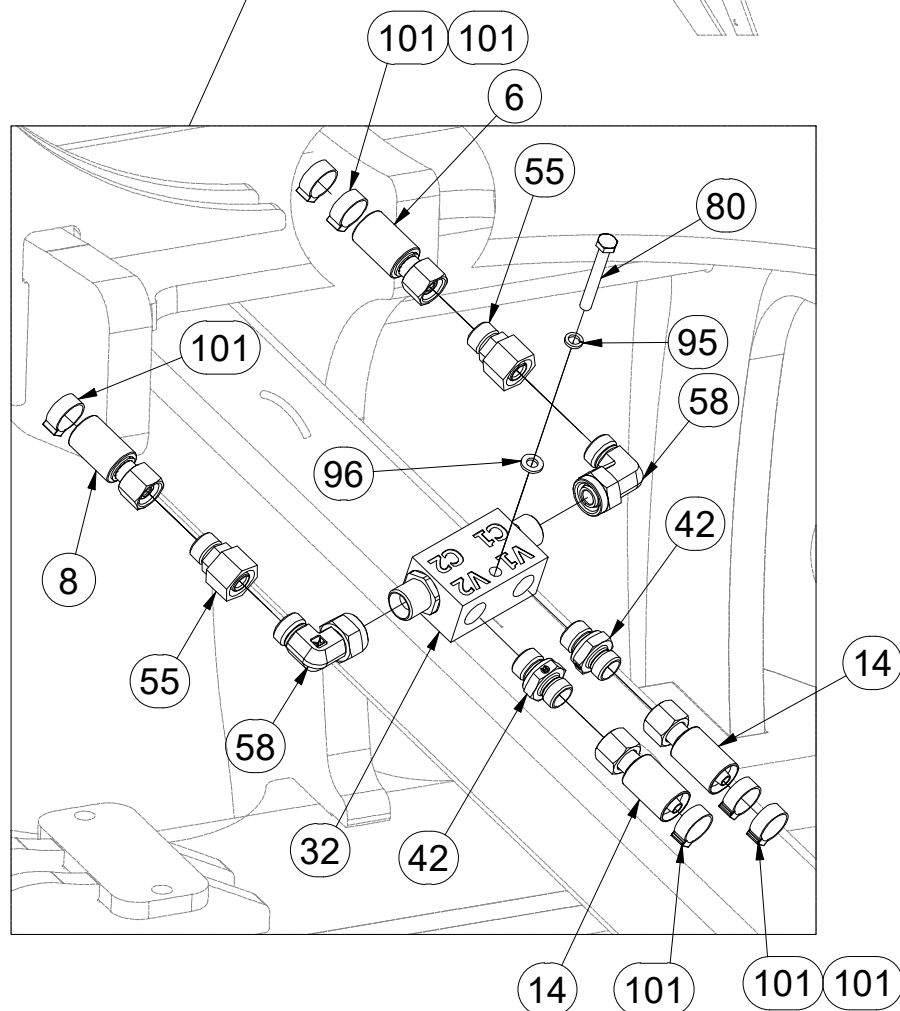
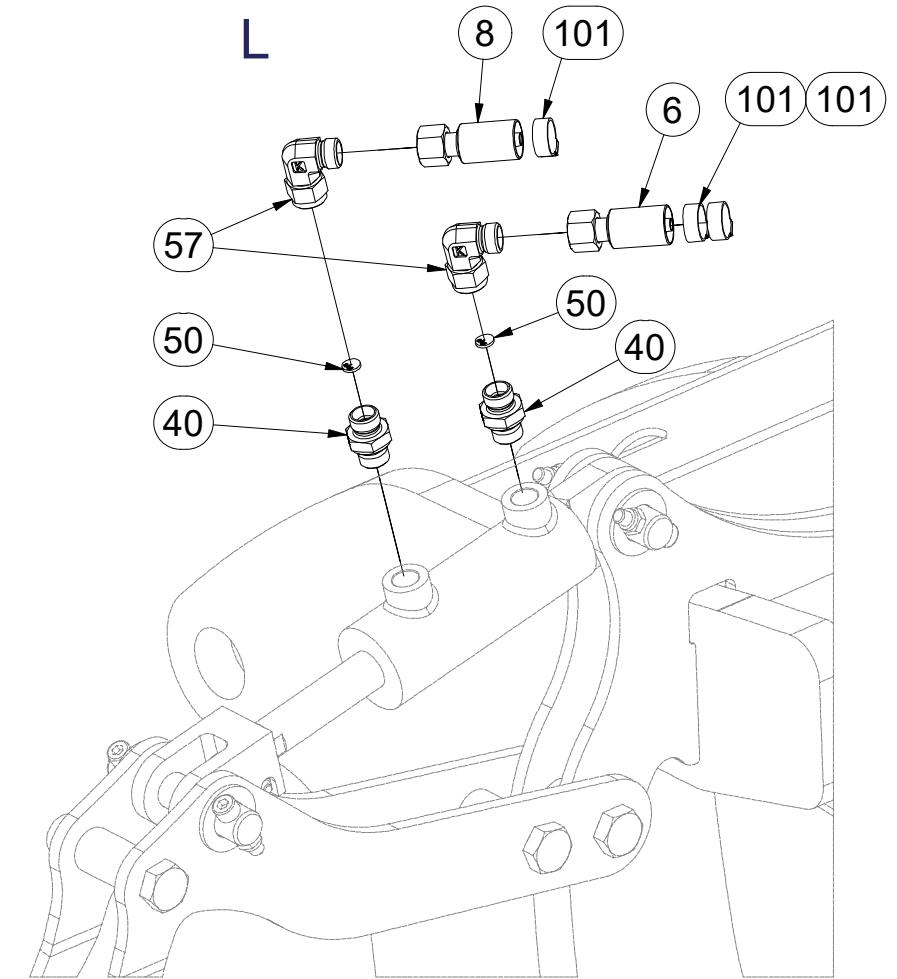
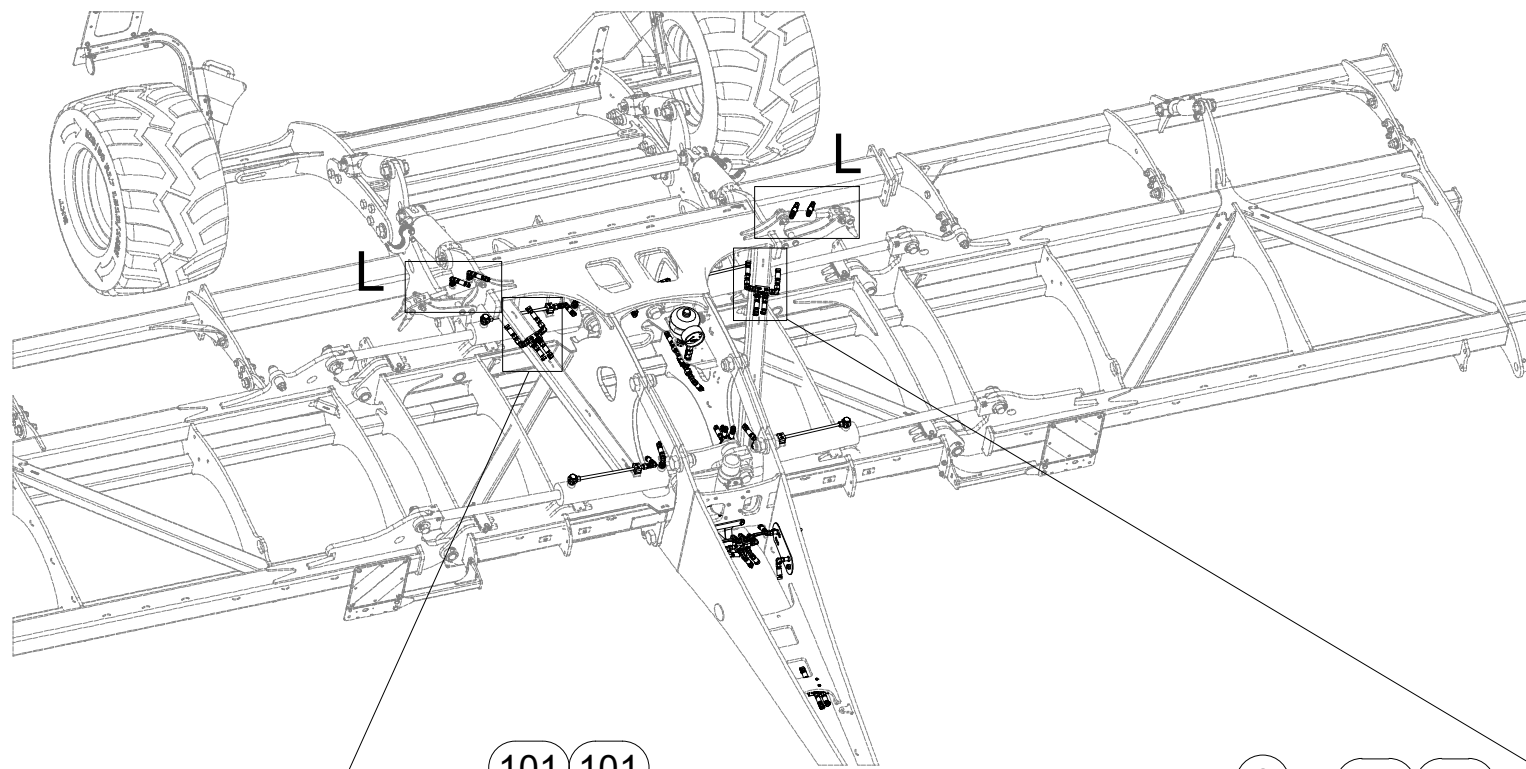

Pos.	Part Number	Pcs.
6	m04827	2
8	m04761	4
12	m07364	2
14	m05210	2
32	m08083	2
40	m07906	4
42	m06528	8
50	m10781	4
55	m09986	4
57	m06803	24
58	m07654	4
80	m04842	2
95	m01200	2
96	m01199	2
101	m11294	92

ⒸZ HYDRAULIKA STROJE

Ⓓ HYDRAULIK DER MASCHINE

Ⓕ HYDRAULIQUE DE LA MACHINE

ⒼB MACHINE HYDRAULICS

ⒺU ГИДРАВЛИКА МАШИНЫ

ⒽL HYDRAULIKA MASZYN



**VZ00020548**

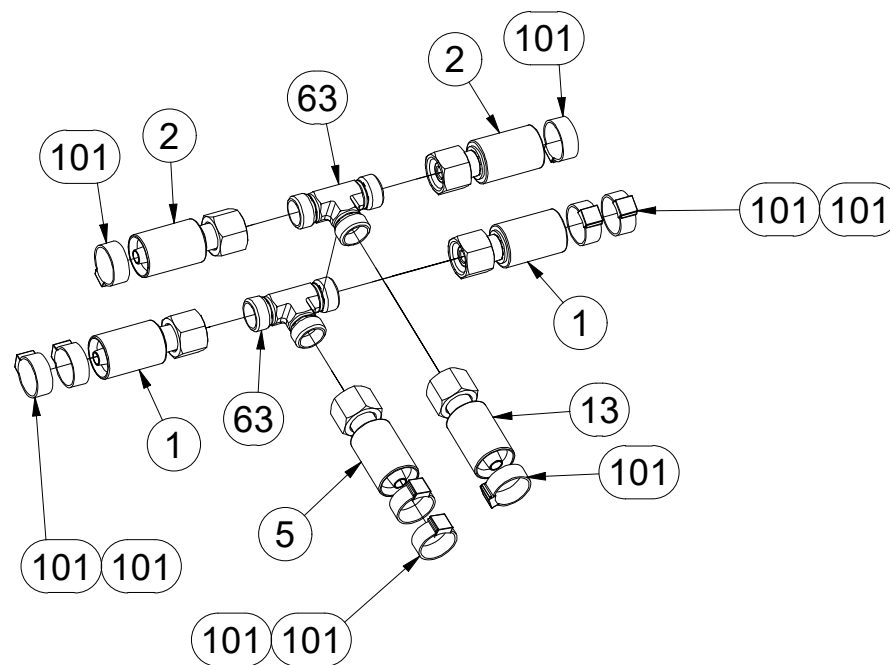
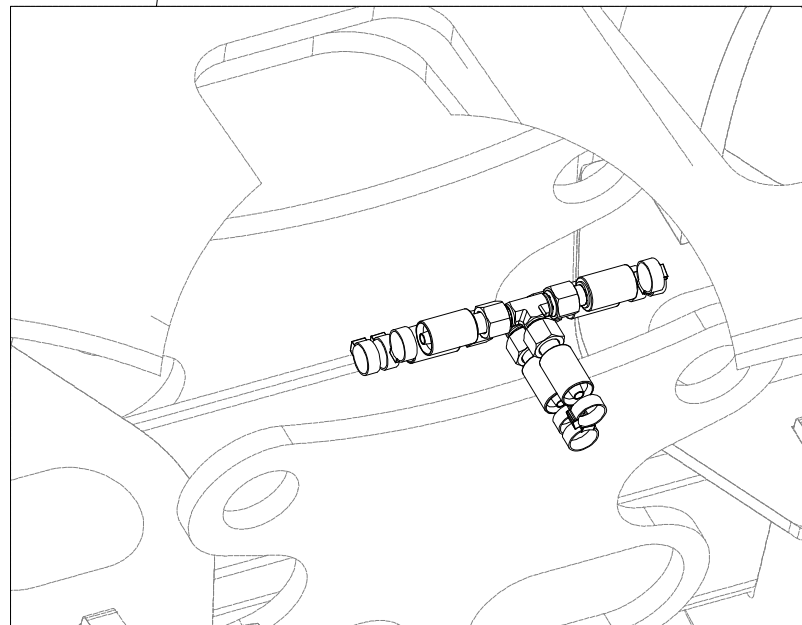
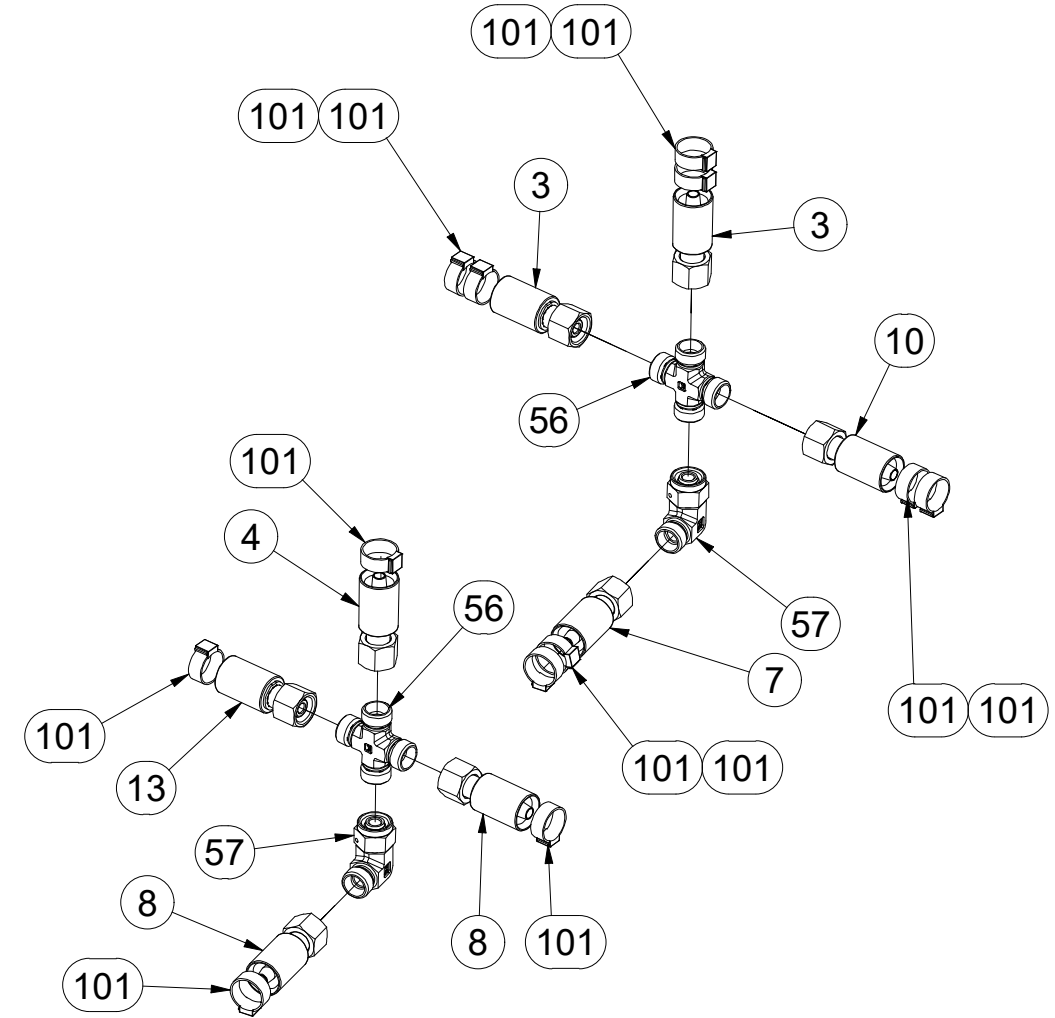
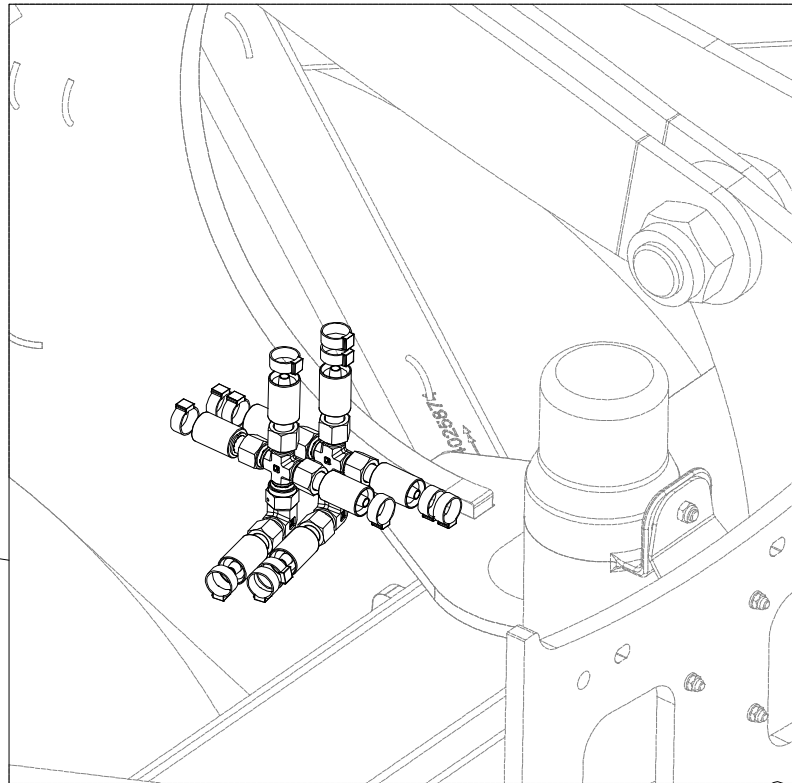
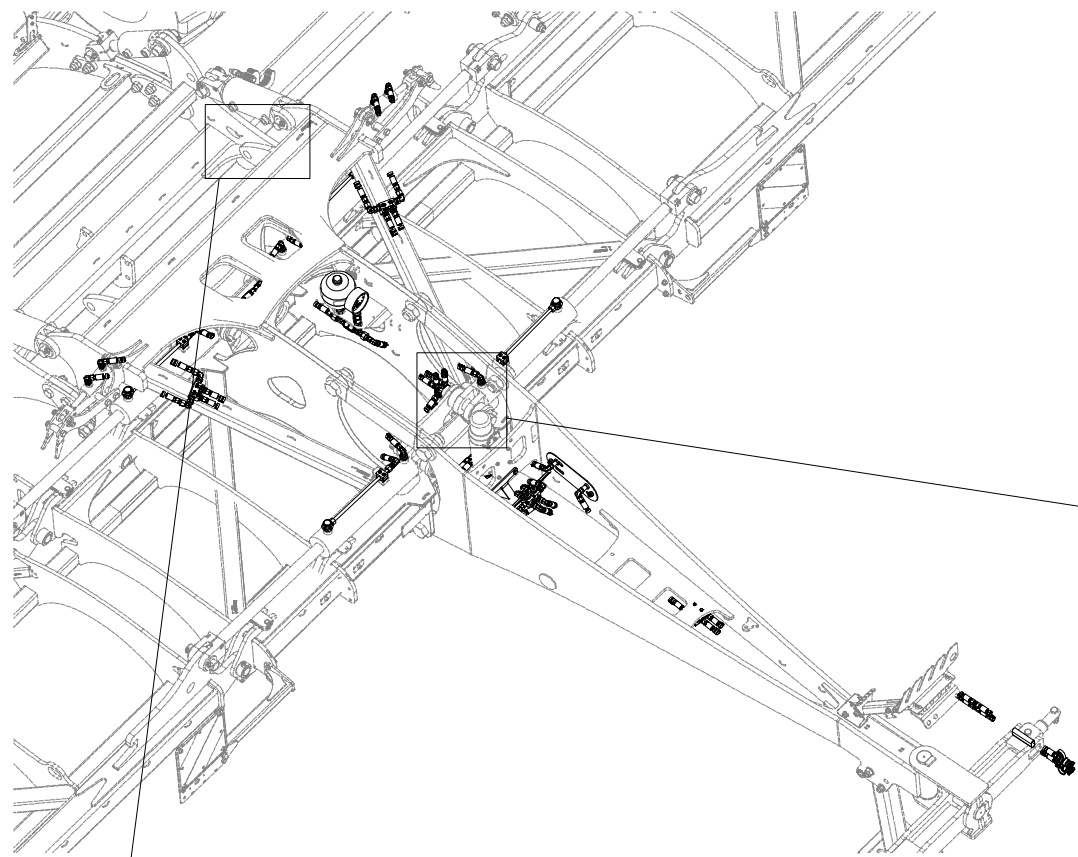

Pos.	Part Number	Pcs.
1	m18193	2
2	m07363	2
3	m09627	3
4	m11000	1
5	m11126	1
7	m09628	1
8	m04761	4
10	m07645	1
13	m03951	2
56	m08328	2
57	m06803	24
63	m03889	4
101	m11294	92

Ⓒ HYDRAULIKA STROJE

Ⓓ HYDRAULIK DER MASCHINE

Ⓕ HYDRAULIQUE DE LA MACHINE

Ⓖ MACHINE HYDRAULICS

Ⓡ ГИДРАВЛИКА МАШИНЫ

Ⓟ HYDRAULIKA MASZYN



**VZ00020548**

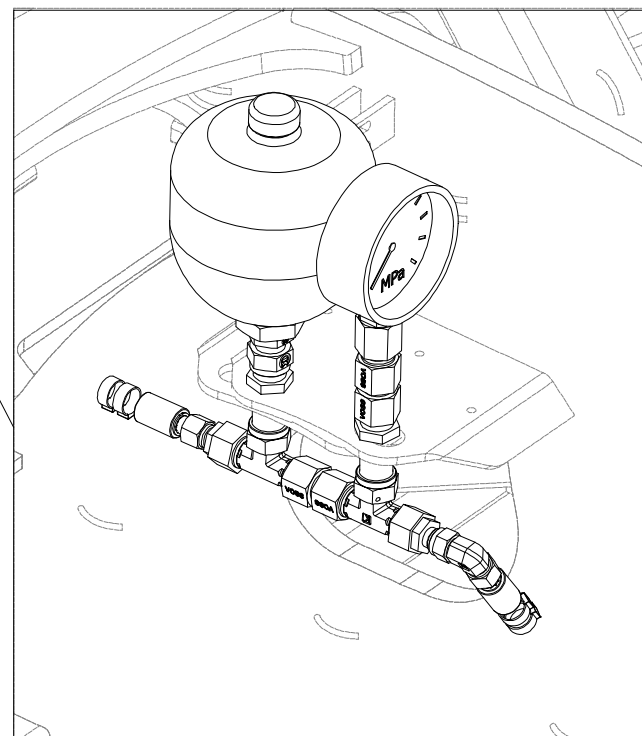
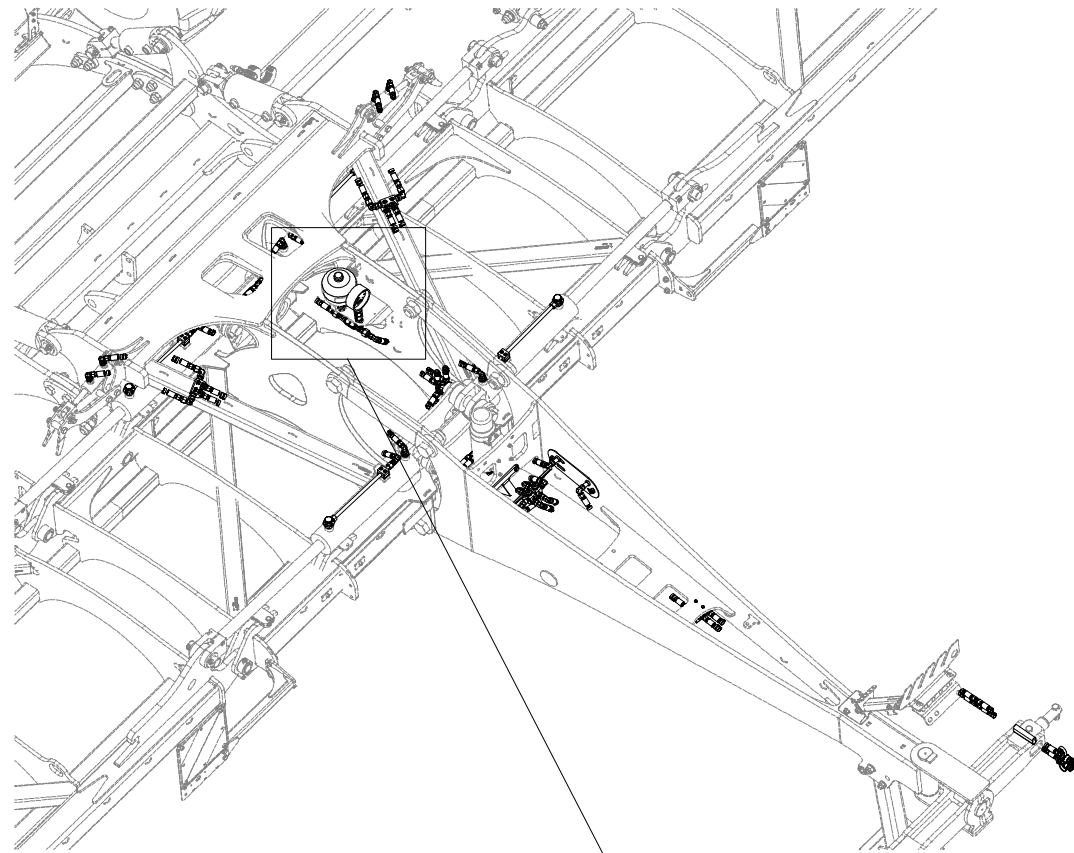

Pos.	Part Number	Pcs.
3	m09627	3
5	m11126	1
30	m09910	1
31	m05518	1
43	m07993	1
45	m04320	1
49	m22307	2
53	m11974	1
54	m08533	2
57	m06803	24
61	m09625	2
64	m06879	2
101	m11294	92

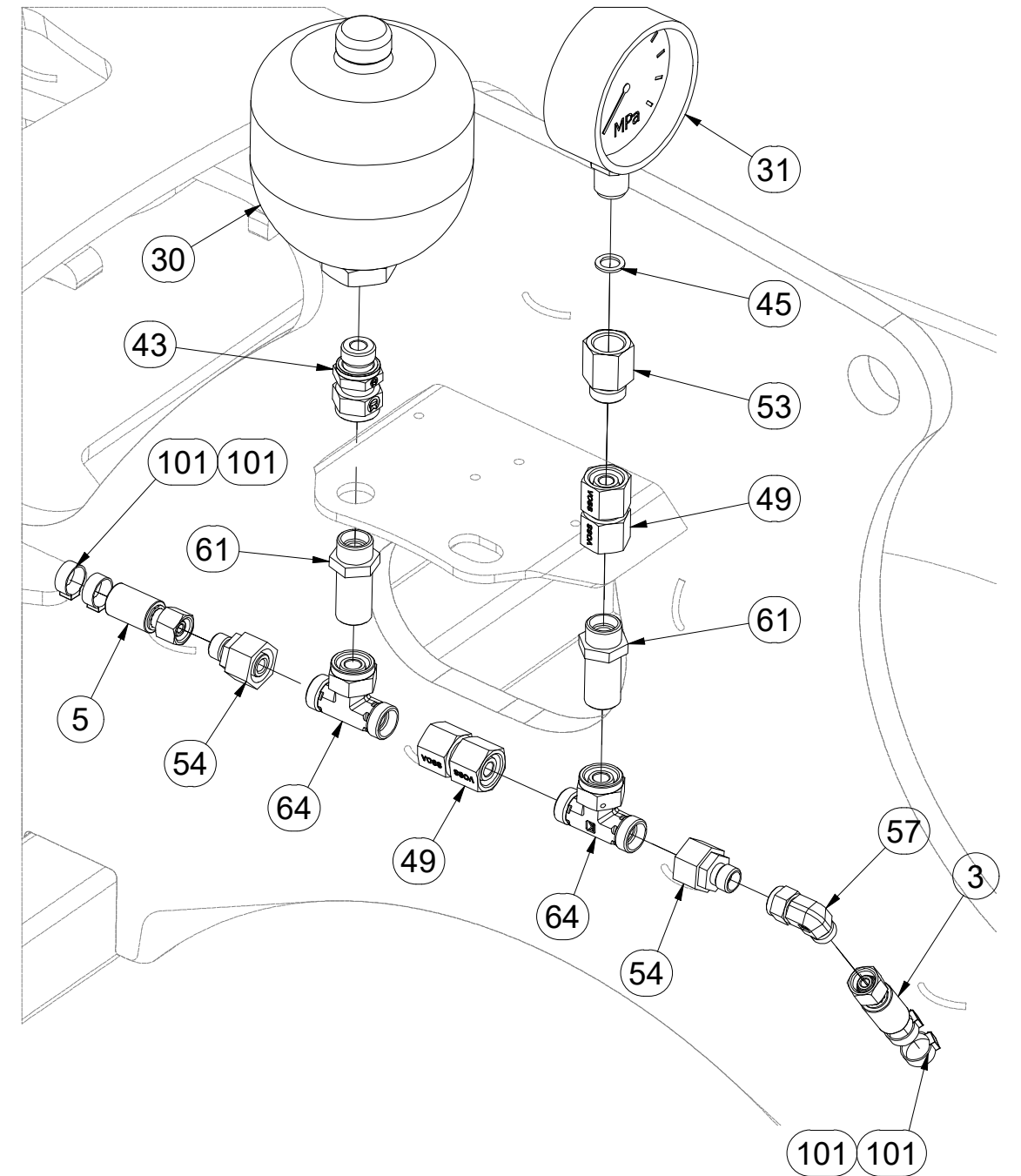

ⒸZ HYDRAULIKA STROJE

Ⓓ HYDRAULIK DER MASCHINE

Ⓕ HYDRAULIQUE DE LA MACHINE

ⒼB MACHINE HYDRAULICS

Ⓔ RU ГИДРАВЛИКА МАШИНЫ

Ⓗ PL HYDRAULIKA MASZYN



**VZ00020548**

Pos.	Part Number	Pcs.	Pos.	Part Number	Pcs.
7	m09628	1	62	m05145	4
8	m04761	4	66	m04317	4
21	m20005	4	67	m20912	4
41	m09934	4	77	VZ00003359	4
47	m17321	8	83	m09464	8
51	m12060	4	101	m11294	92
57	m06803	24			

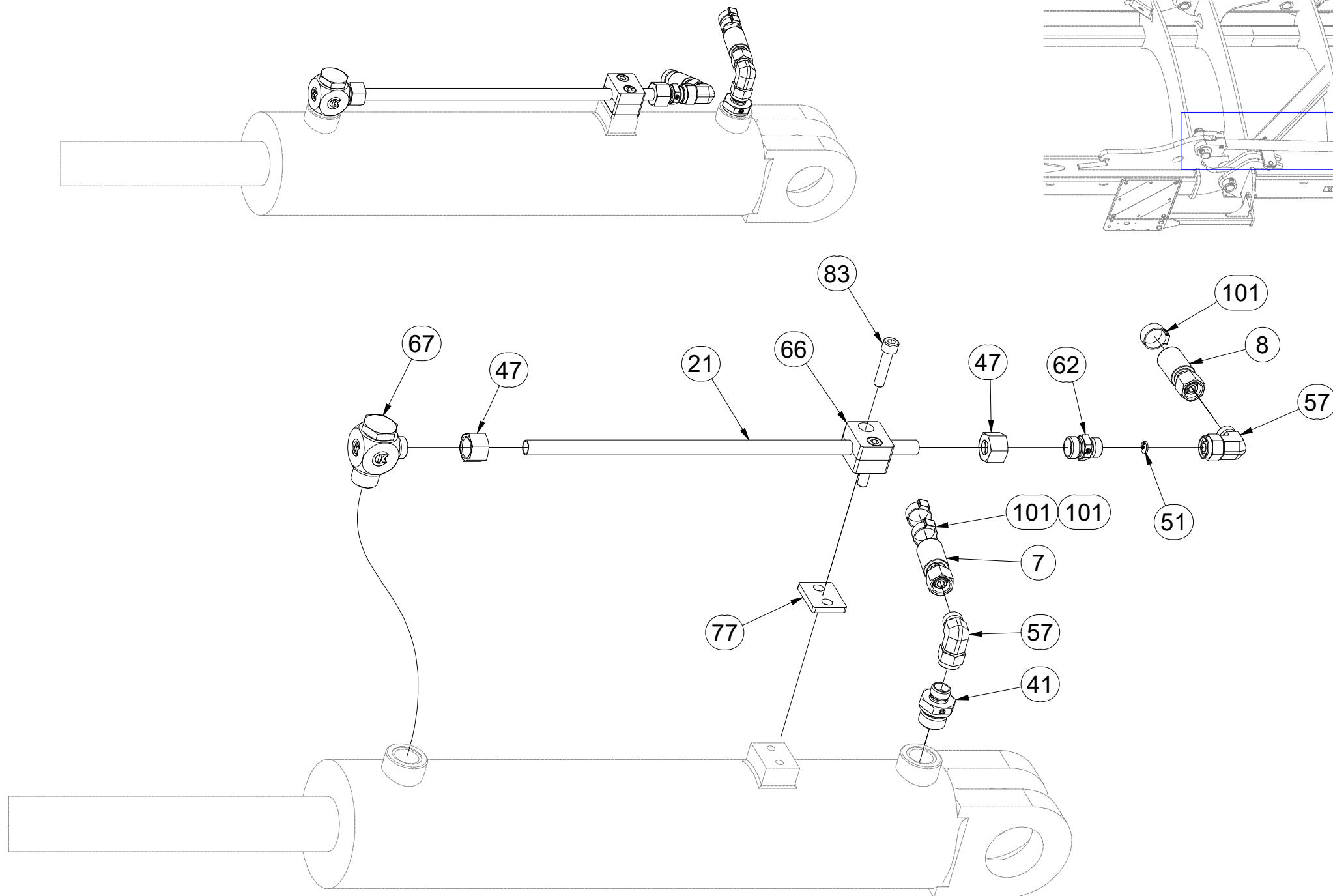
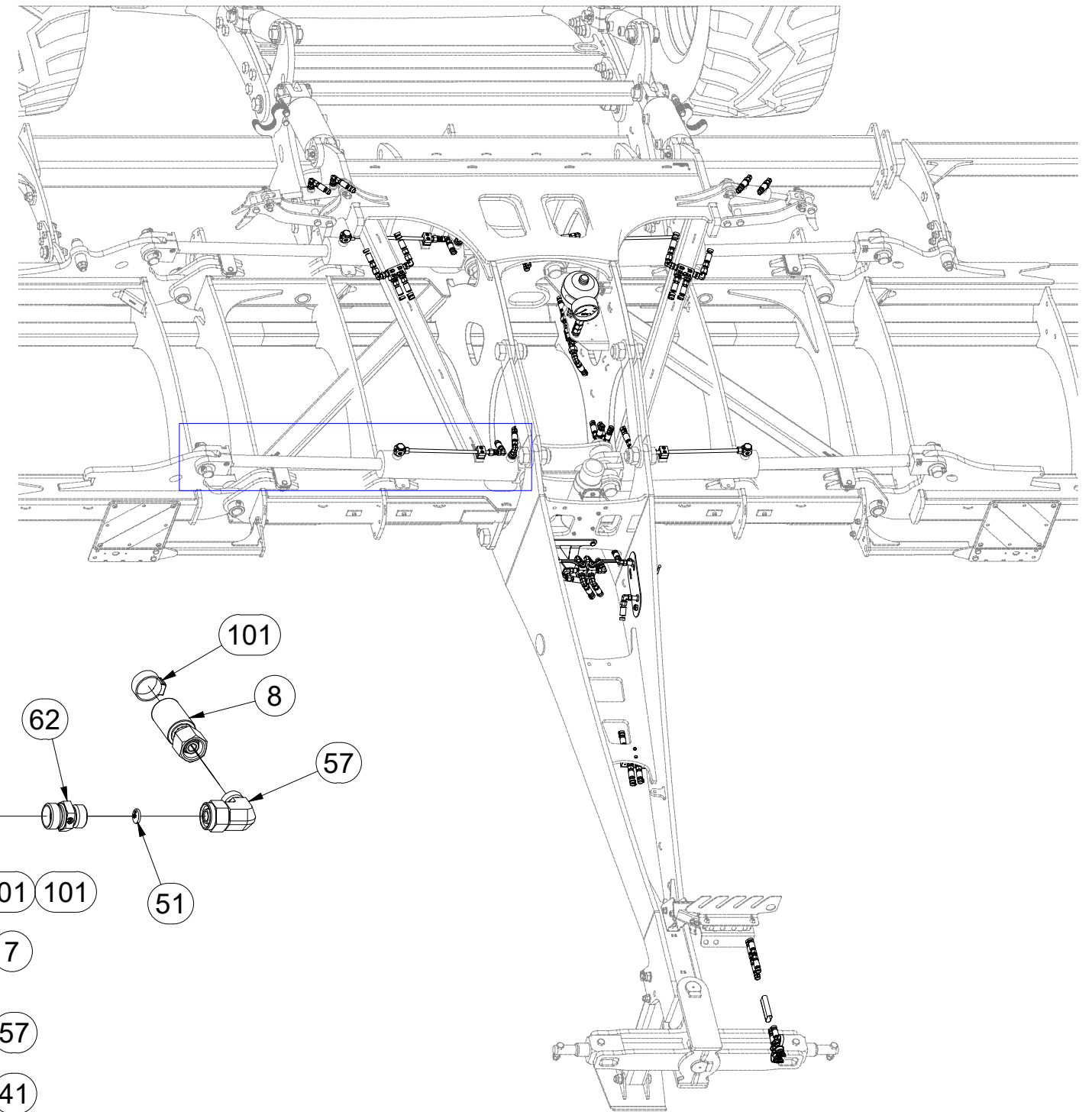

Ⓒ HYDRAULIKA STROJE

Ⓓ HYDRAULIK DER MASCHINE

Ⓕ HYDRAULIQUE DE LA MACHINE

Ⓖ MACHINE HYDRAULICS

Ⓡ ГИДРАВЛИКА МАШИНЫ

Ⓟ HYDRAULIKA MASZYN



**VZ00020548**

Pos.	Part Number	Pcs.	Pos.	Part Number	Pcs.
1	m18193	2	62	m05145	4
2	m07363	2	66	m04317	4
21	m20005	4	67	m20912	4
41	m09934	4	77	VZ00003359	4
47	m17321	8	83	m09464	8
51	m12060	4	101	m11294	92
57	m06803	24			

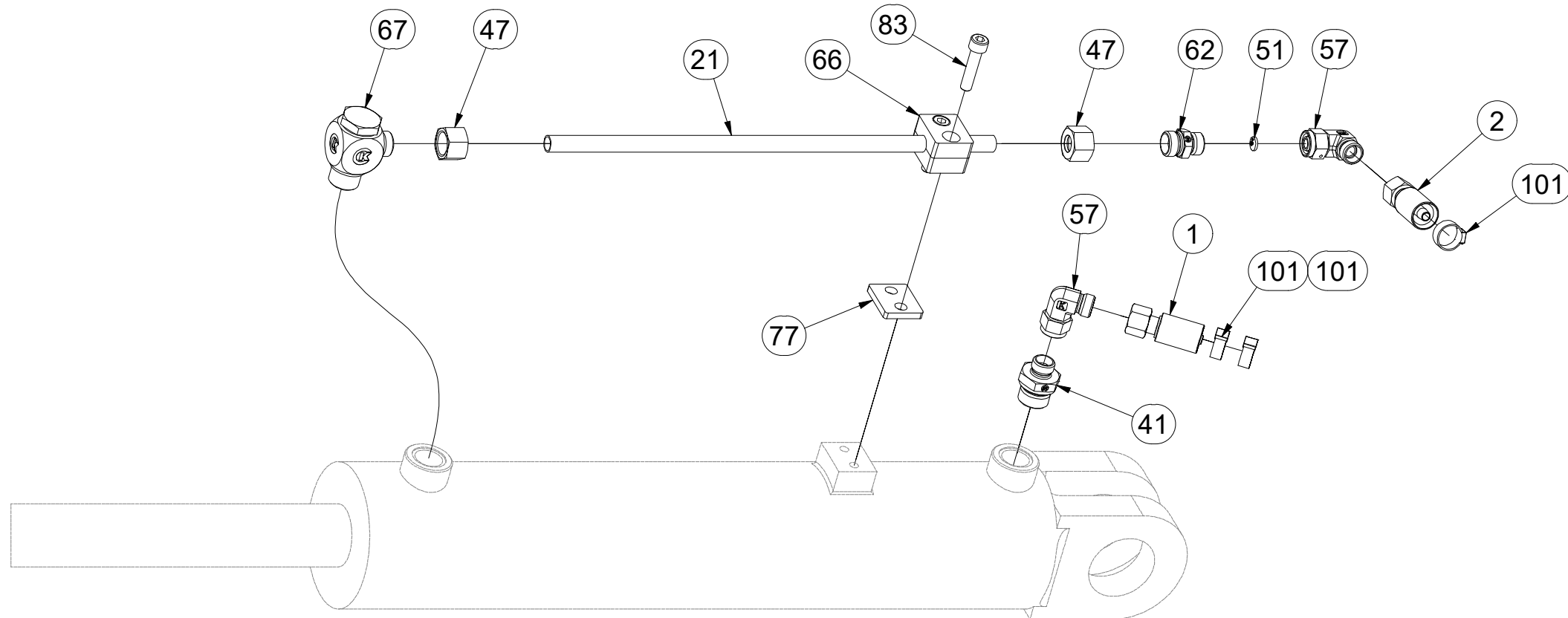
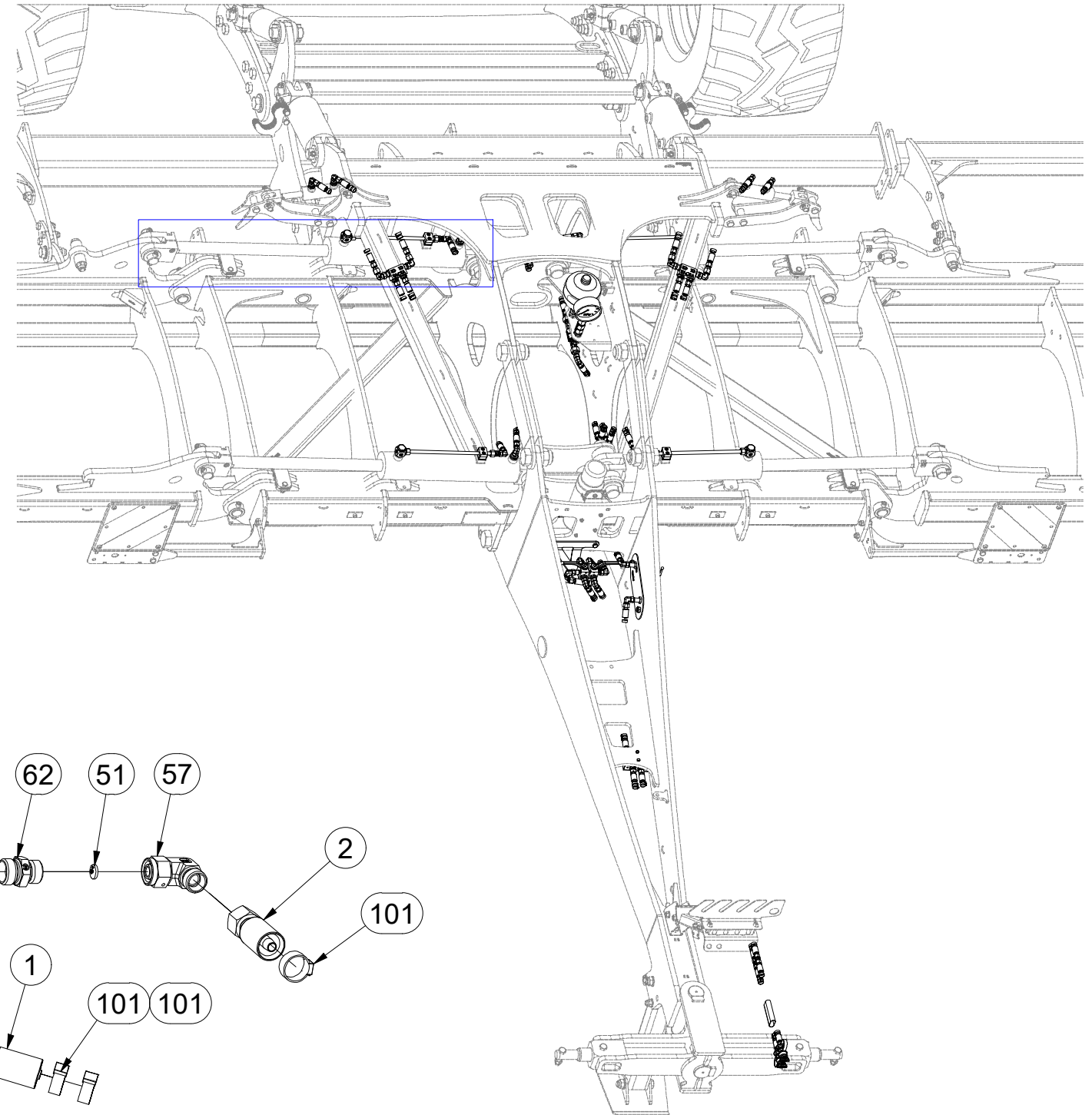
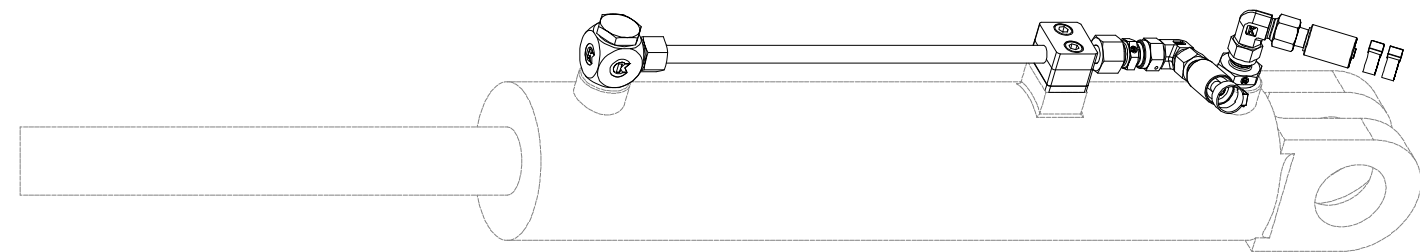

ⒸZ HYDRAULIKA STROJE

Ⓓ HYDRAULIK DER MASCHINE

Ⓕ HYDRAULIQUE DE LA MACHINE

ⒸB MACHINE HYDRAULICS

ⒸR ГИДРАВЛИКА МАШИНЫ

ⒸL HYDRAULIKA MASZYN



**VZ00020548**

Pos.	Part Number	Pcs.	Pos.	Part Number	Pcs.
3	m09627	3	62	m05145	4
4	m11000	1	66	m04317	4
21	m20005	4	67	m20912	4
41	m09934	4	77	VZ00003359	4
47	m17321	8	83	m09464	8
51	m12060	4	101	m11294	92
57	m06803	24			

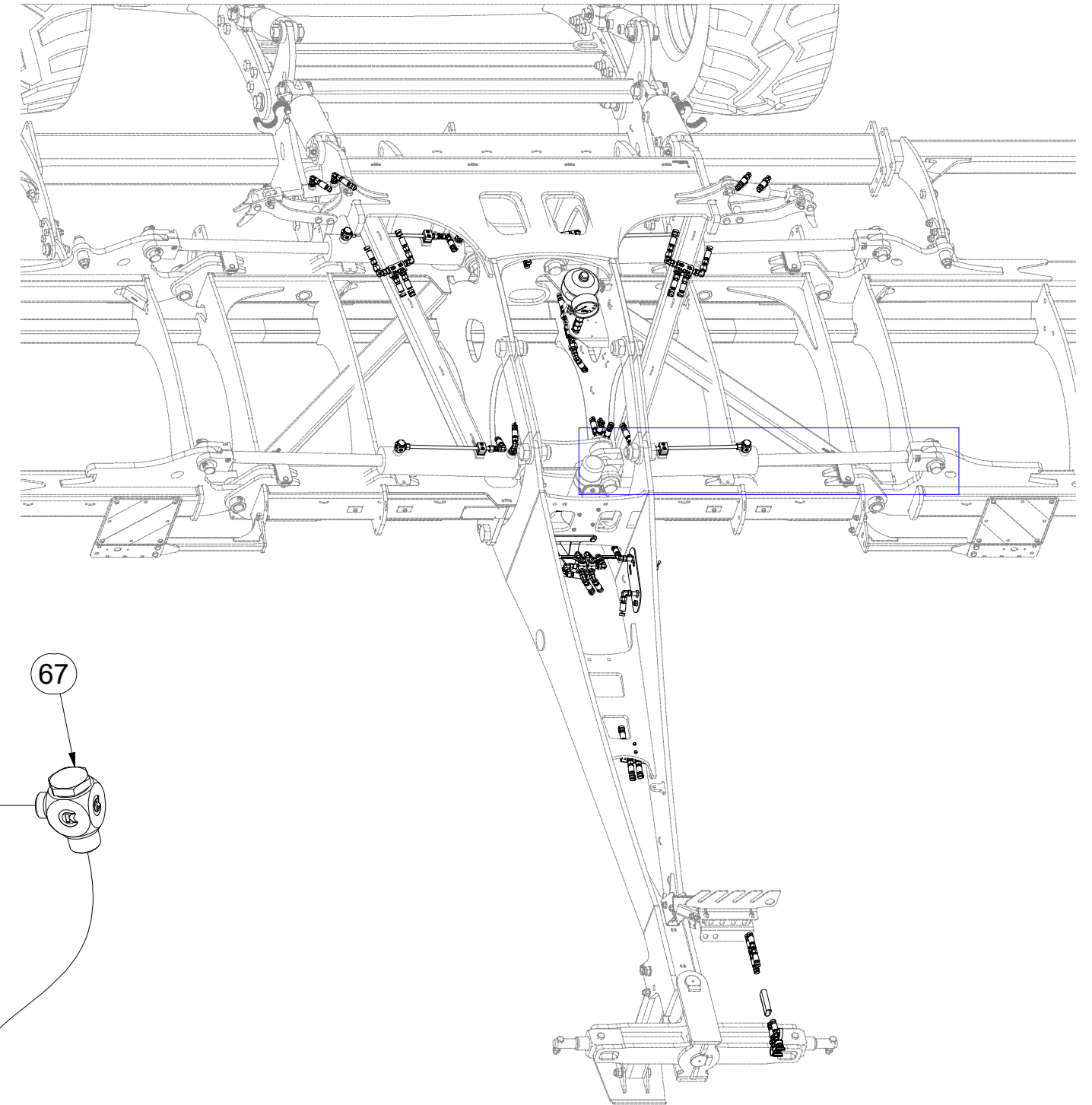
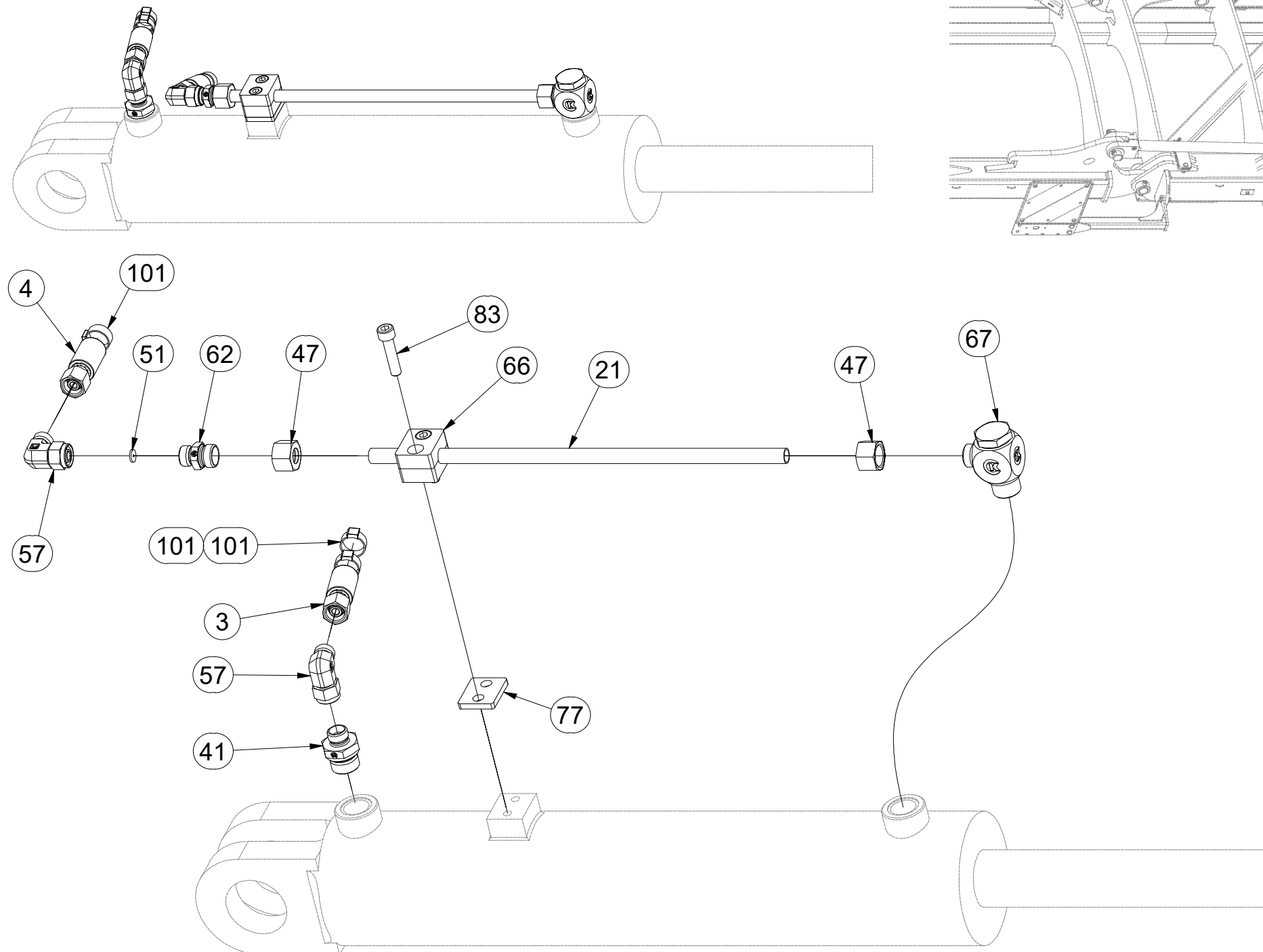

ⒸZ HYDRAULIKA STROJE

Ⓓ HYDRAULIK DER MASCHINE

Ⓕ HYDRAULIQUE DE LA MACHINE

ⒼB MACHINE HYDRAULICS

Ⓔ RU ГИДРАВЛИКА МАШИНЫ

Ⓗ PL HYDRAULIKA MASZYN



**VZ00020548**

Pos.	Part Number	Pcs.	Pos.	Part Number	Pcs.
1	m18193	2	62	m05145	4
2	m07363	2	66	m04317	4
21	m20005	4	67	m20912	4
41	m09934	4	77	VZ00003359	4
47	m17321	8	83	m09464	8
51	m12060	4	101	m11294	92
57	m06803	24			

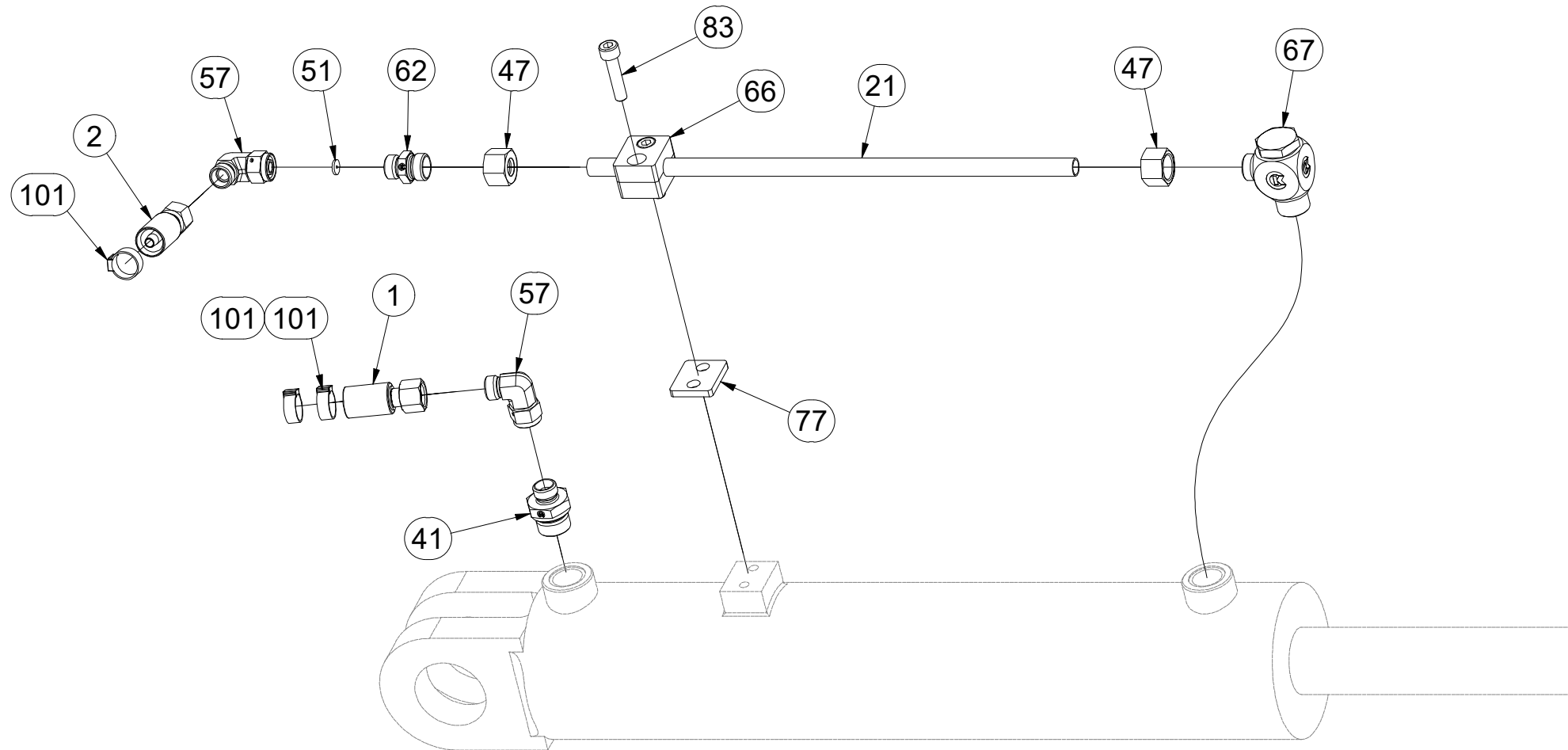
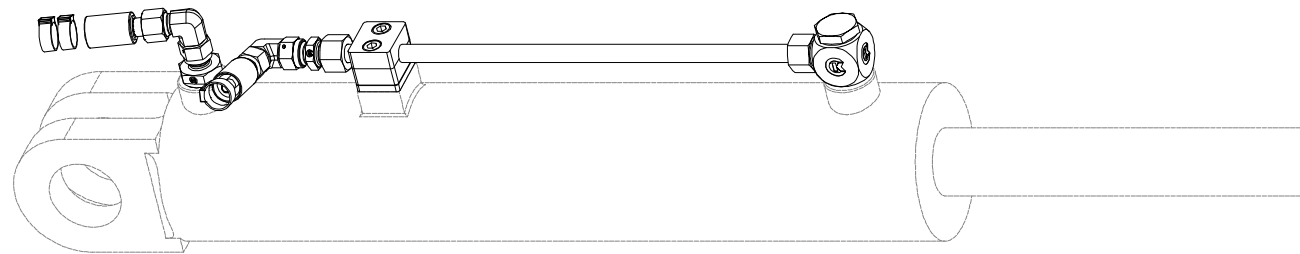
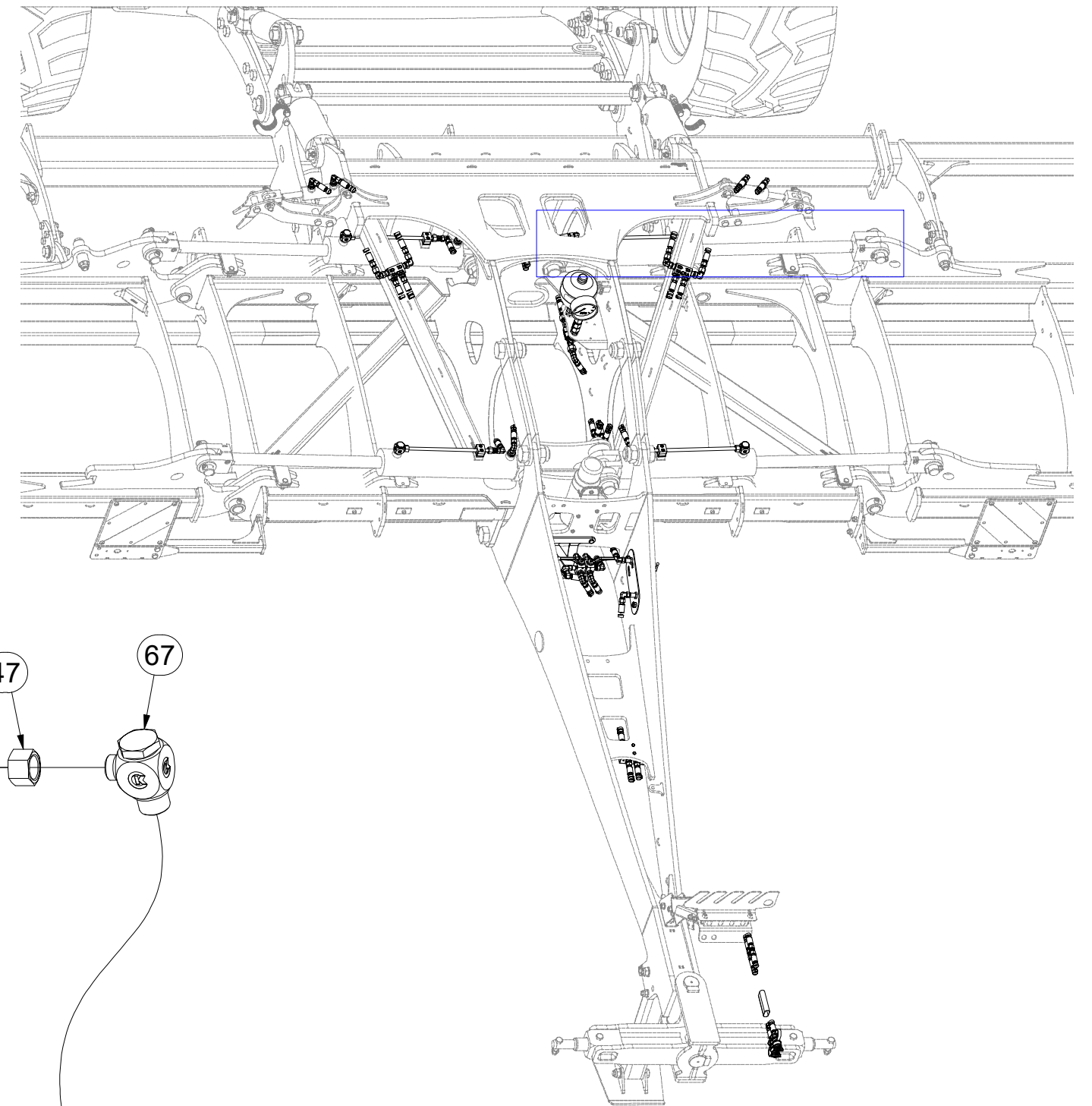

ⒸZ HYDRAULIKA STROJE

ⒸD HYDRAULIK DER MASCHINE

ⒸF HYDRAULIQUE DE LA MACHINE

ⒸGB MACHINE HYDRAULICS

ⒸRU ГИДРАВЛИКА МАШИНЫ

ⒸPL HYDRAULIKA MASZYN



**VZ00020552**

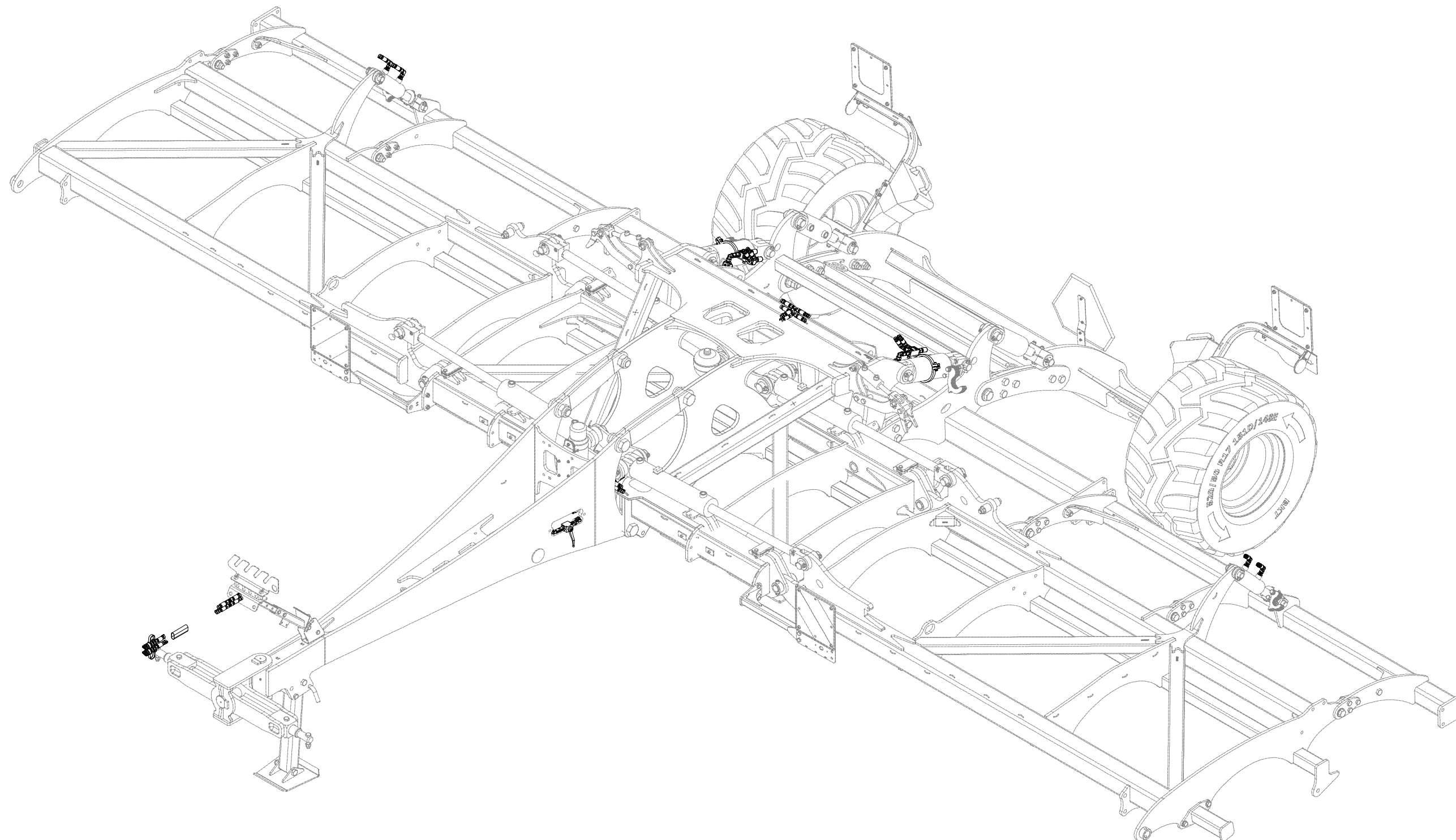



ⒸZ HYDRAULIKA STROJE

ⒸD HYDRAULIK DER MASCHINE

ⒸF HYDRAULIQUE DE LA MACHINE

ⒸB MACHINE HYDRAULICS

ⒸRU ГИДРАВЛИКА МАШИНЫ

ⒸPL HYDRAULIKA MASZYNY



**VZ00020552**

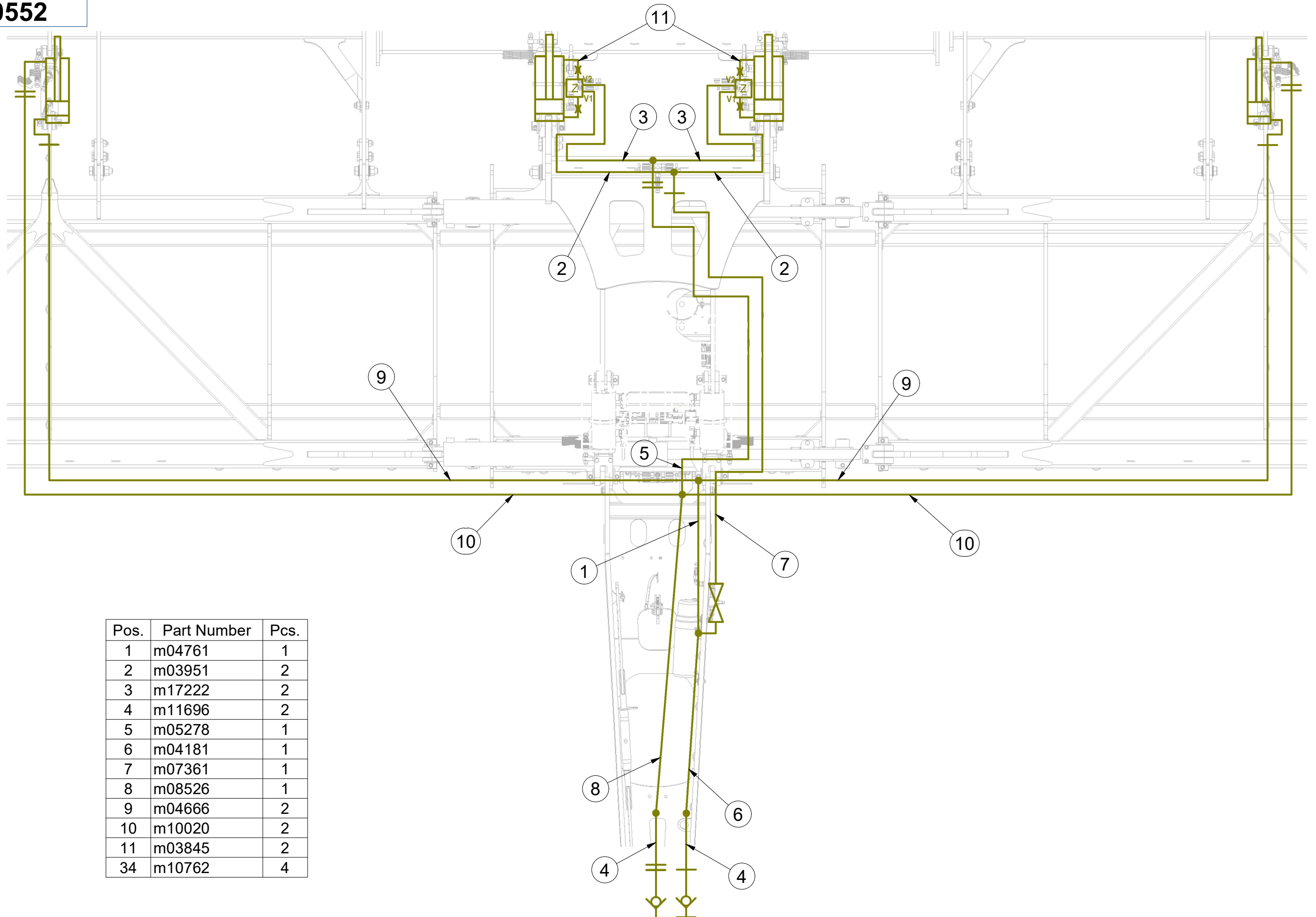

Pos.	Part Number	Pcs.
1	m04761	1
2	m03951	2
3	m17222	2
4	m11696	2
5	m05278	1
6	m04181	1
7	m07361	1
8	m08526	1
9	m04666	2
10	m10020	2
11	m03845	2
34	m10762	4

ⒸZ HYDRAULIKA STROJE

Ⓓ HYDRAULIK DER MASCHINE

Ⓕ HYDRAULIQUE DE LA MACHINE

ⒸB MACHINE HYDRAULICS

ⒸR ГИДРАВЛИКА МАШИНЫ

ⒸL HYDRAULIKA MASZYN



**VZ00020552**

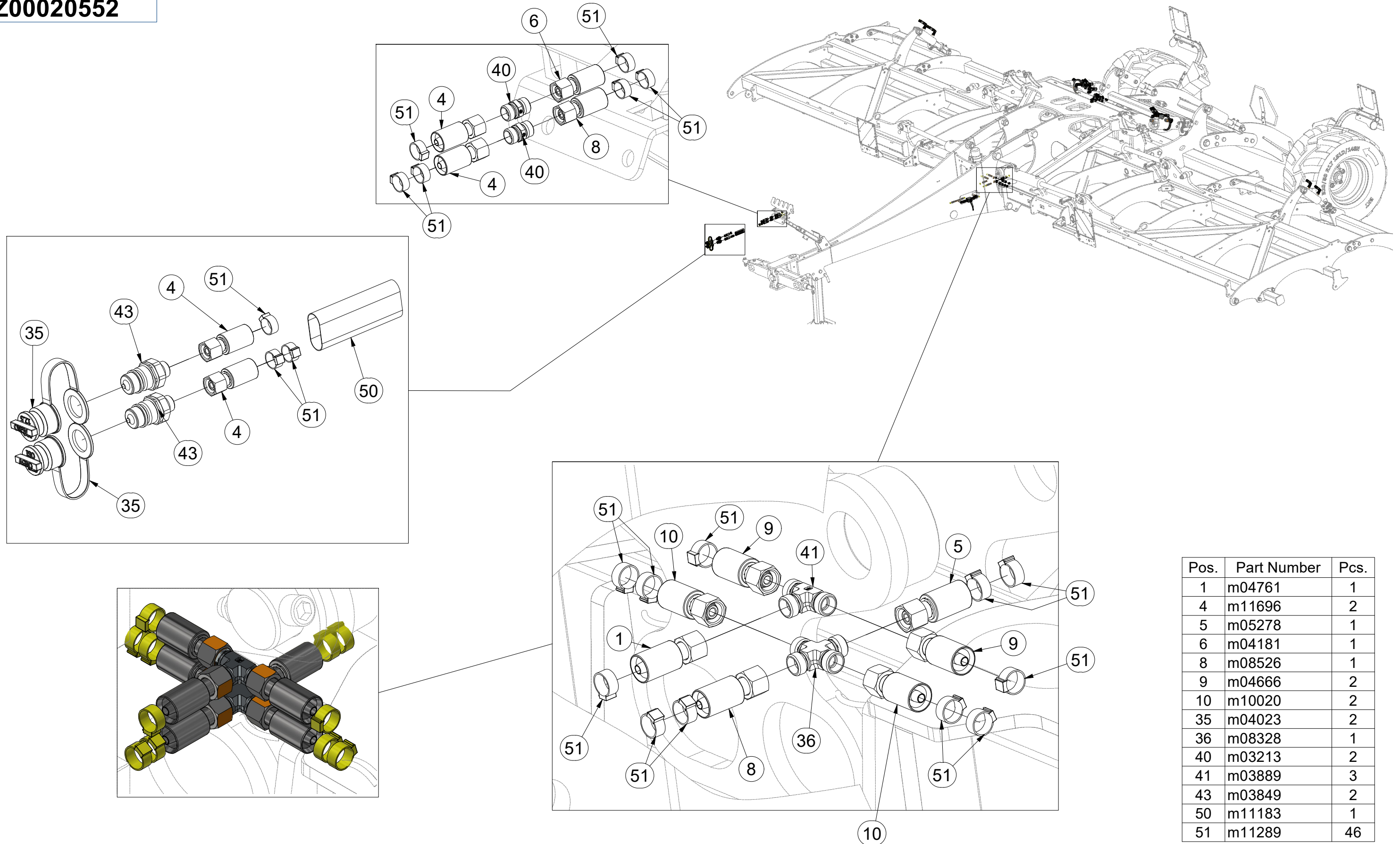

Pos.	Part Number	Pcs.
1	m04761	1
4	m11696	2
5	m05278	1
6	m04181	1
8	m08526	1
9	m04666	2
10	m10020	2
35	m04023	2
36	m08328	1
40	m03213	2
41	m03889	3
43	m03849	2
50	m11183	1
51	m11289	46

ⒸZ HYDRAULIKA STROJE

Ⓓ HYDRAULIK DER MASCHINE

Ⓕ HYDRAULIQUE DE LA MACHINE

ⒼB MACHINE HYDRAULICS

Ⓔ RU ГИДРАВЛИКА МАШИНЫ

Ⓗ PL HYDRAULIKA MASZYN



**VZ00020552**

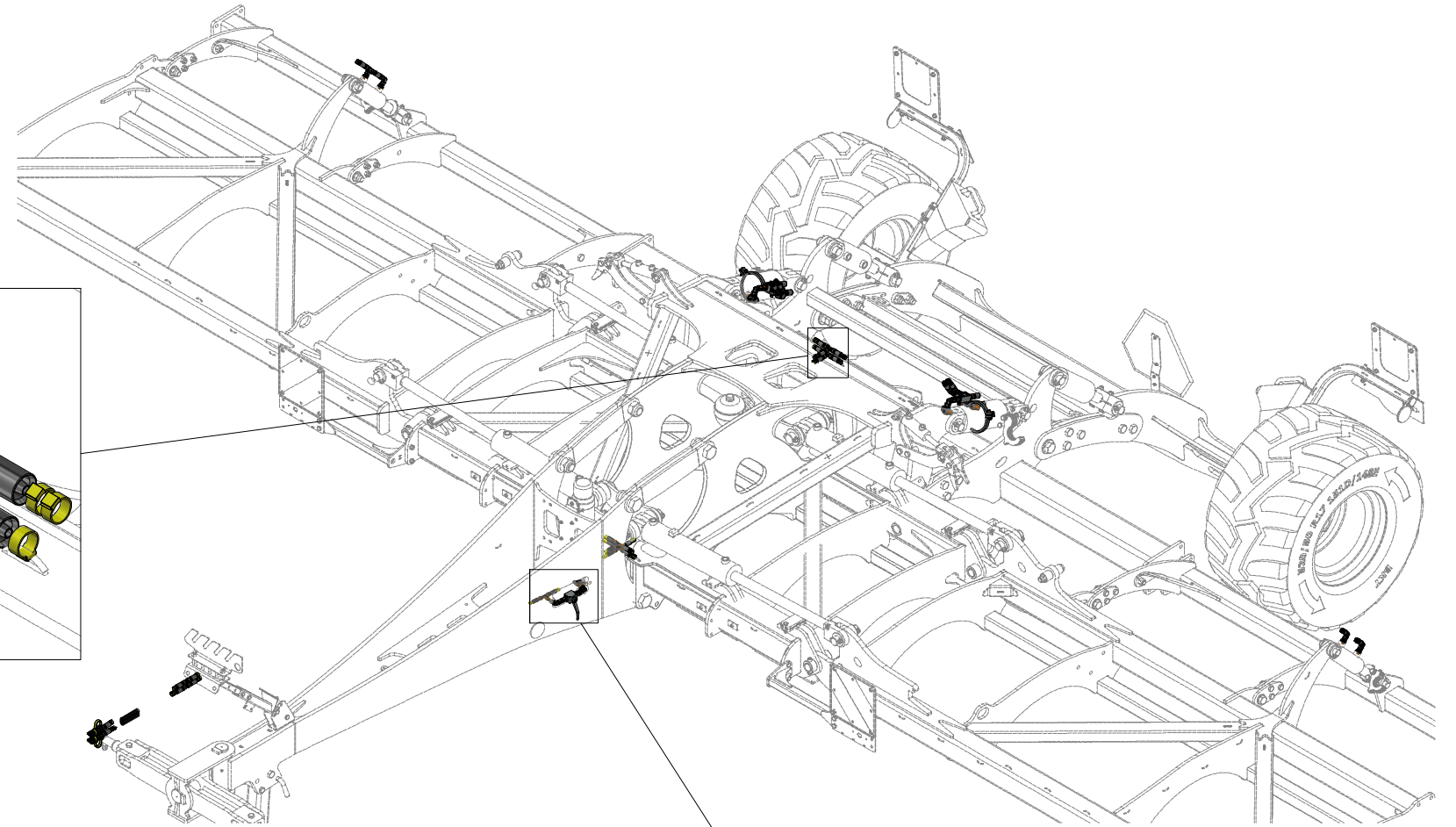
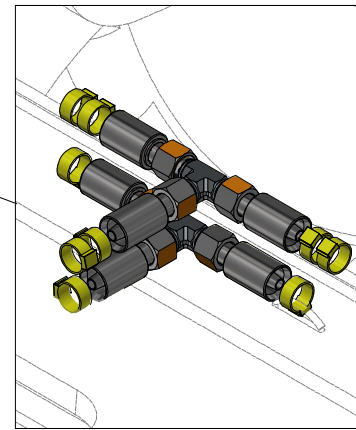
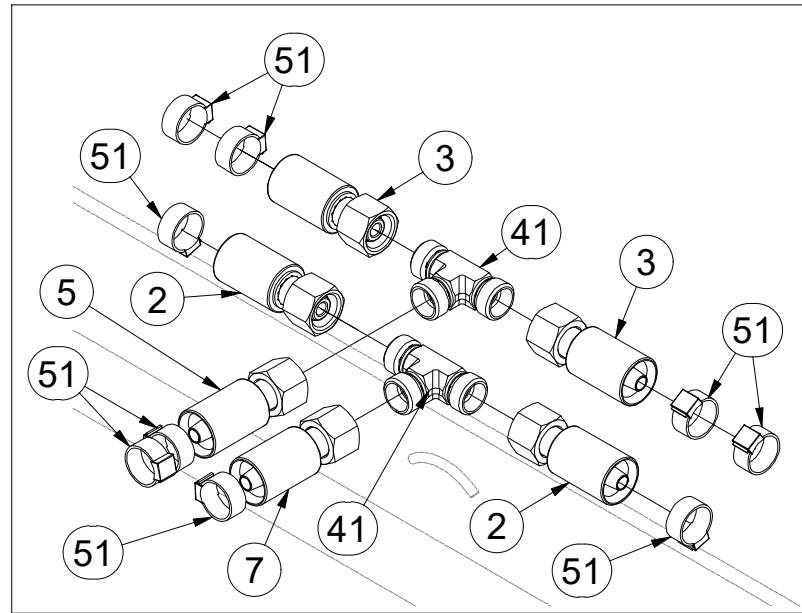

Pos.	Part Number	Pcs.
1	m04761	1
2	m03951	2
3	m17222	2
5	m05278	1
6	m04181	1
7	m07361	1
21	m04623	1
32	m22305	2
37	m06803	9
39	m08391	2
41	m03889	3
42	m07567	1
51	m11289	46

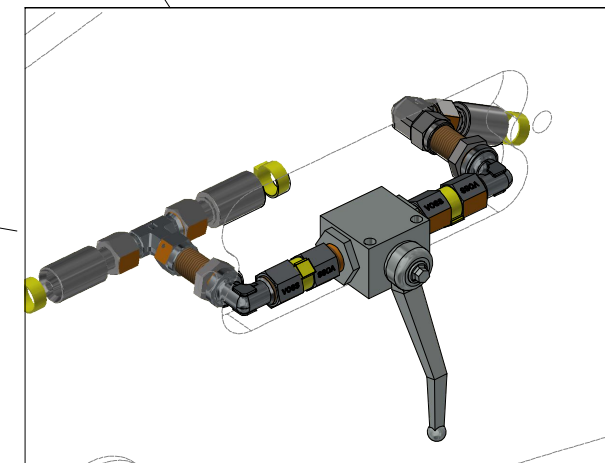
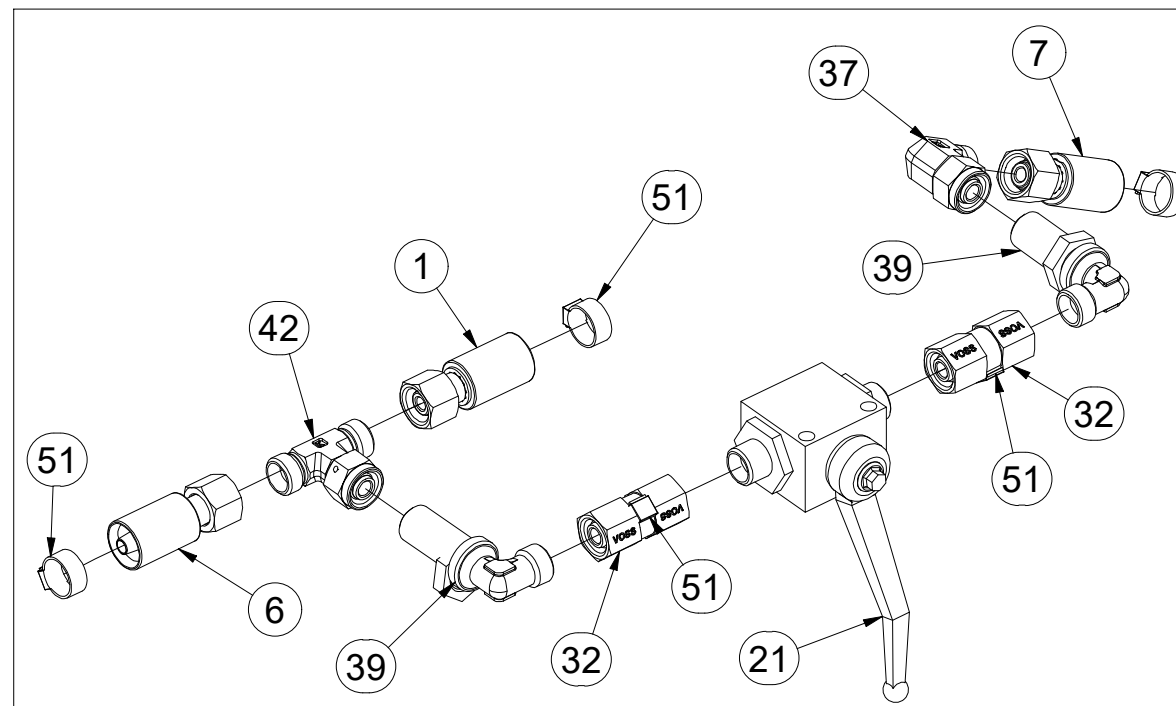

ⒸZ HYDRAULIKA STROJE

Ⓓ HYDRAULIK DER MASCHINE

Ⓕ HYDRAULIQUE DE LA MACHINE

ⒸB MACHINE HYDRAULICS

ⒸR ГИДРАВЛИКА МАШИНЫ

ⒸL HYDRAULIKA MASZYNY



**VZ00020552**

Pos.	Part Number	Pcs.
2	m03951	2
3	m17222	2
11	m03845	2
20	m08083	2
31	m06528	4
33	m22306	2
34	m10762	4
37	m06803	9
38	m07654	2
44	m20912	4
51	m11289	46
60	VZ00010112	2

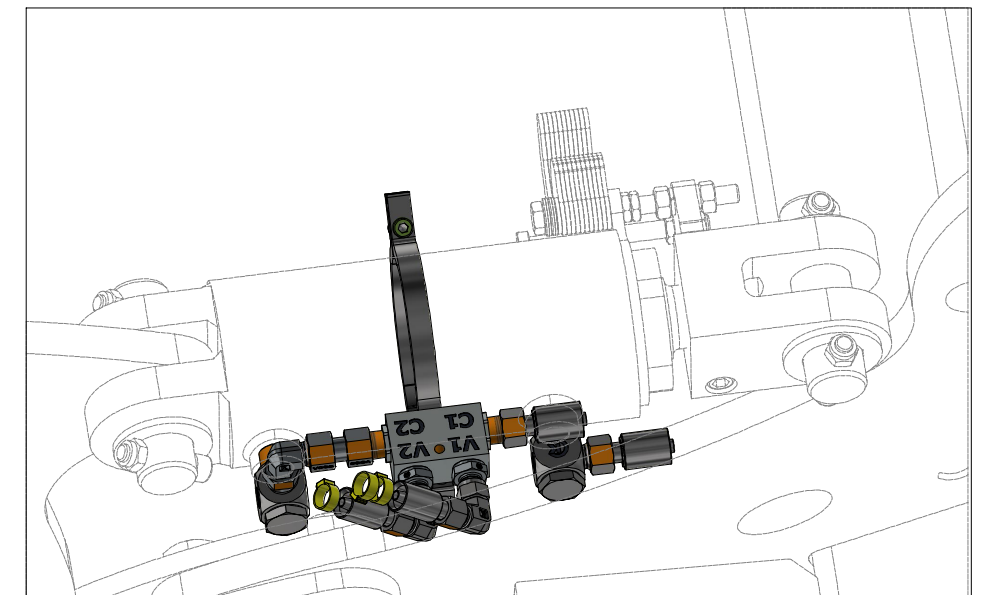
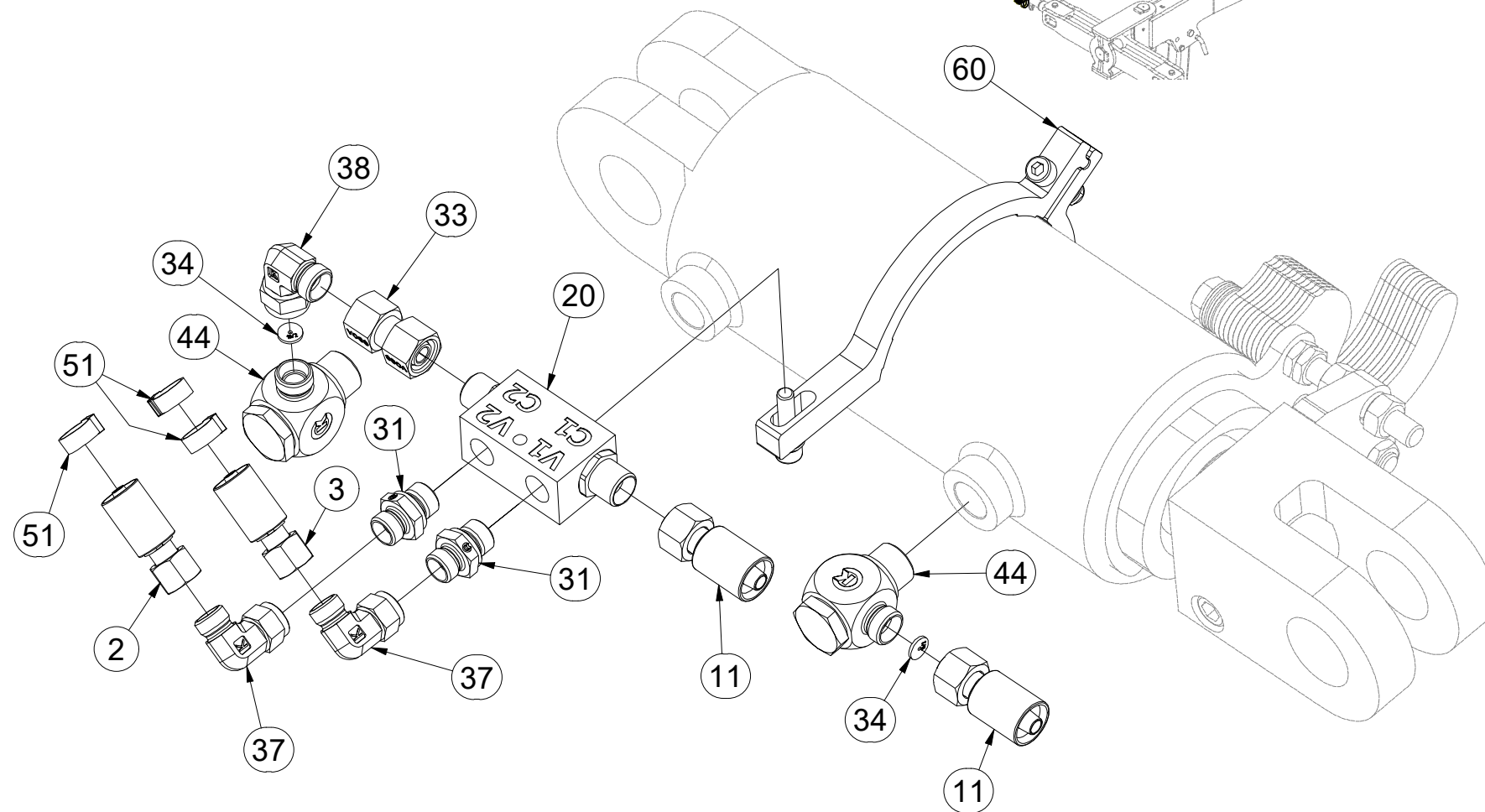
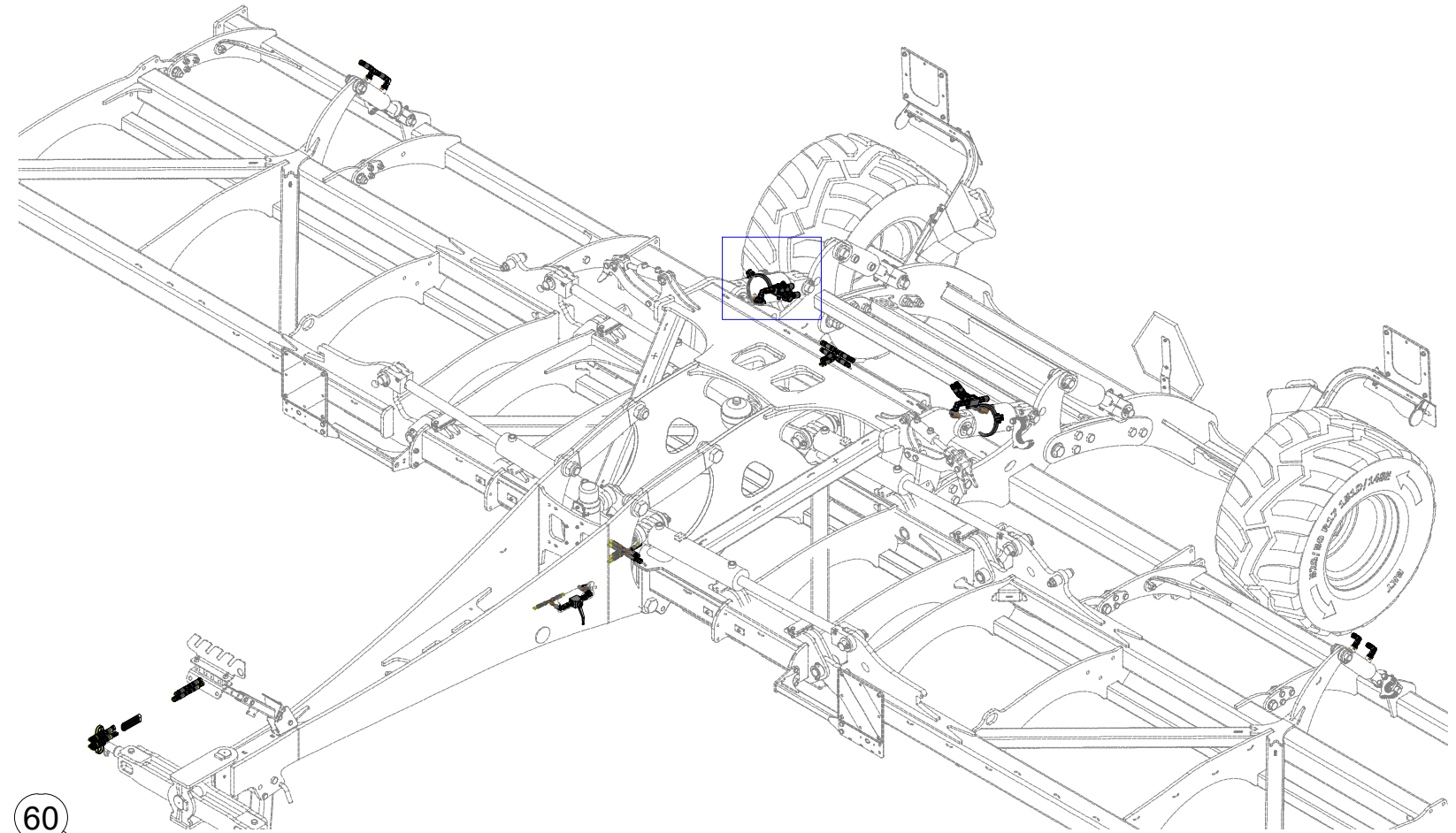

ⒸZ HYDRAULIKA STROJE

Ⓓ HYDRAULIK DER MASCHINE

Ⓕ HYDRAULIQUE DE LA MACHINE

ⒼB MACHINE HYDRAULICS

Ⓔ RU ГИДРАВЛИКА МАШИНЫ

Ⓗ PL HYDRAULIKA MASZYN



**VZ00020552**

Pos.	Part Number	Pcs.
2	m03951	2
3	m17222	2
11	m03845	2
20	m08083	2
31	m06528	4
33	m22306	2
34	m10762	4
37	m06803	9
38	m07654	2
44	m20912	4
51	m11289	46
60	VZ00010112	2

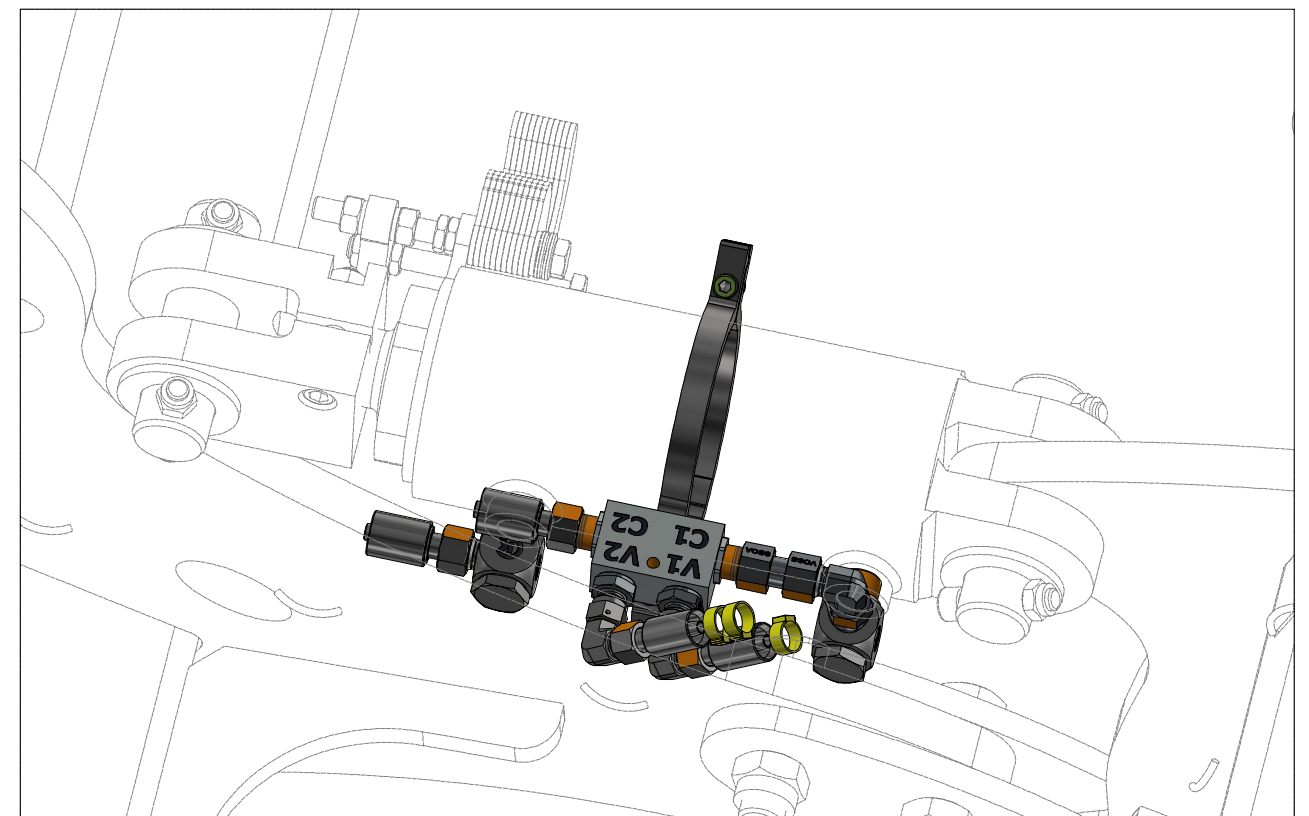
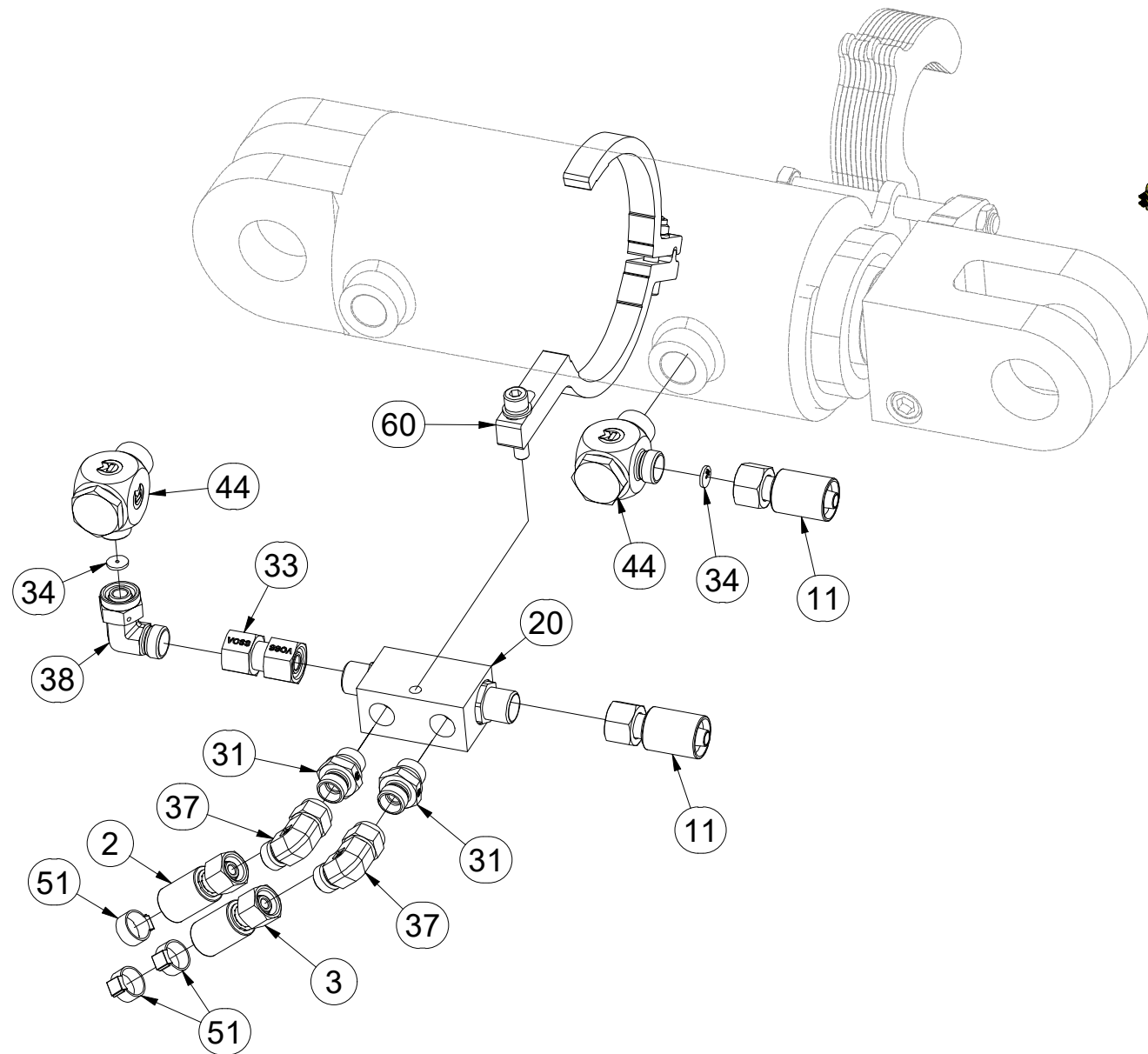
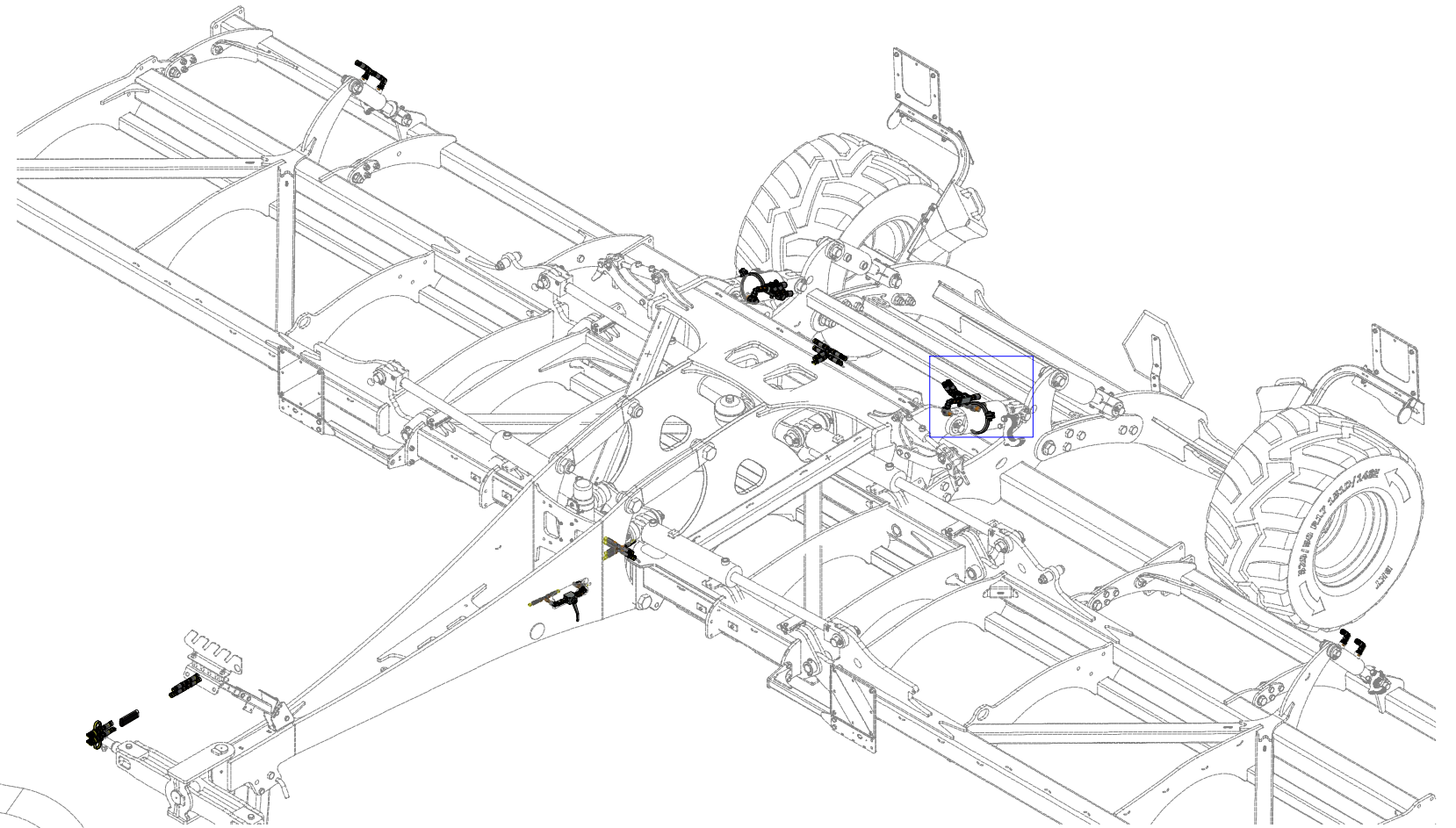

Ⓒ HYDRAULIKA STROJE

Ⓓ HYDRAULIK DER MASCHINE

Ⓕ HYDRAULIQUE DE LA MACHINE

Ⓖ MACHINE HYDRAULICS

Ⓡ ГИДРАВЛИКА МАШИНЫ

Ⓟ HYDRAULIKA MASZYN



**VZ00020552**

Pos.	Part Number	Pcs.
9	m04666	2
10	m10020	2
30	m07906	4
37	m06803	9
51	m11289	46

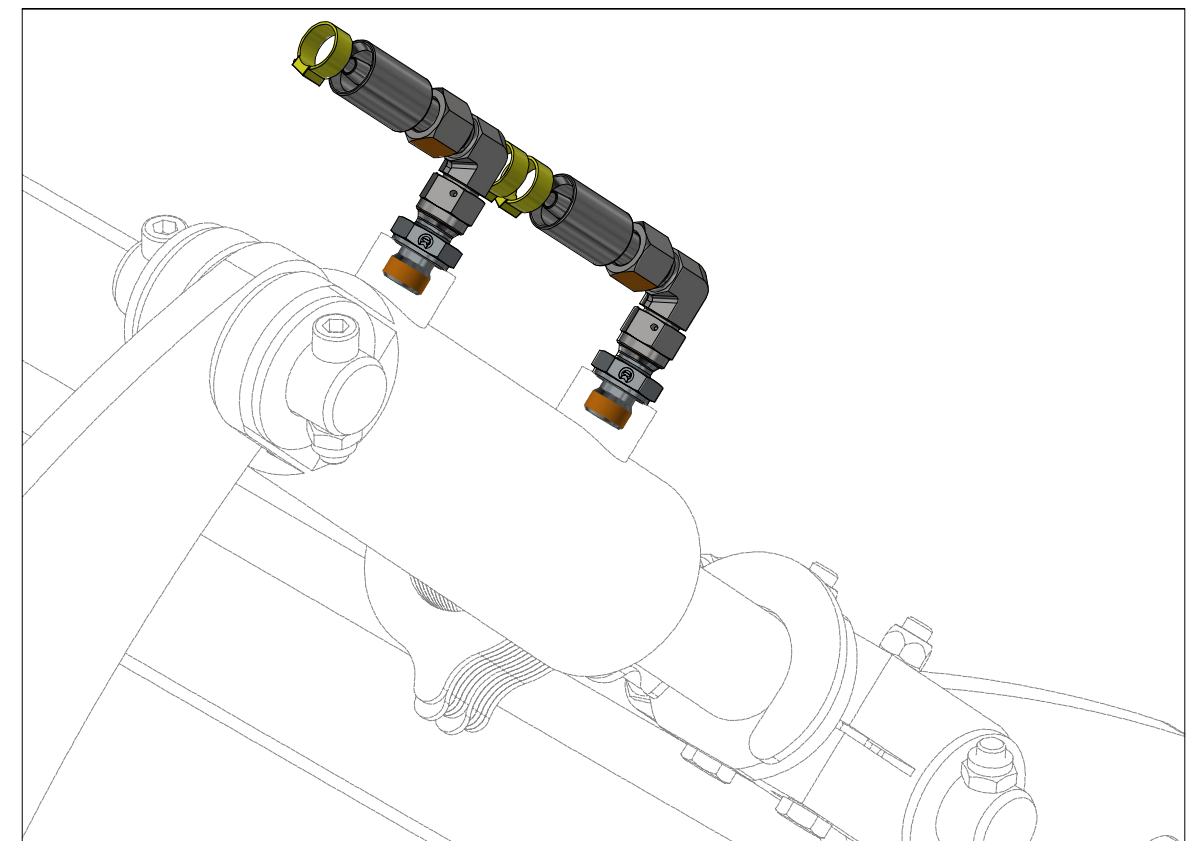
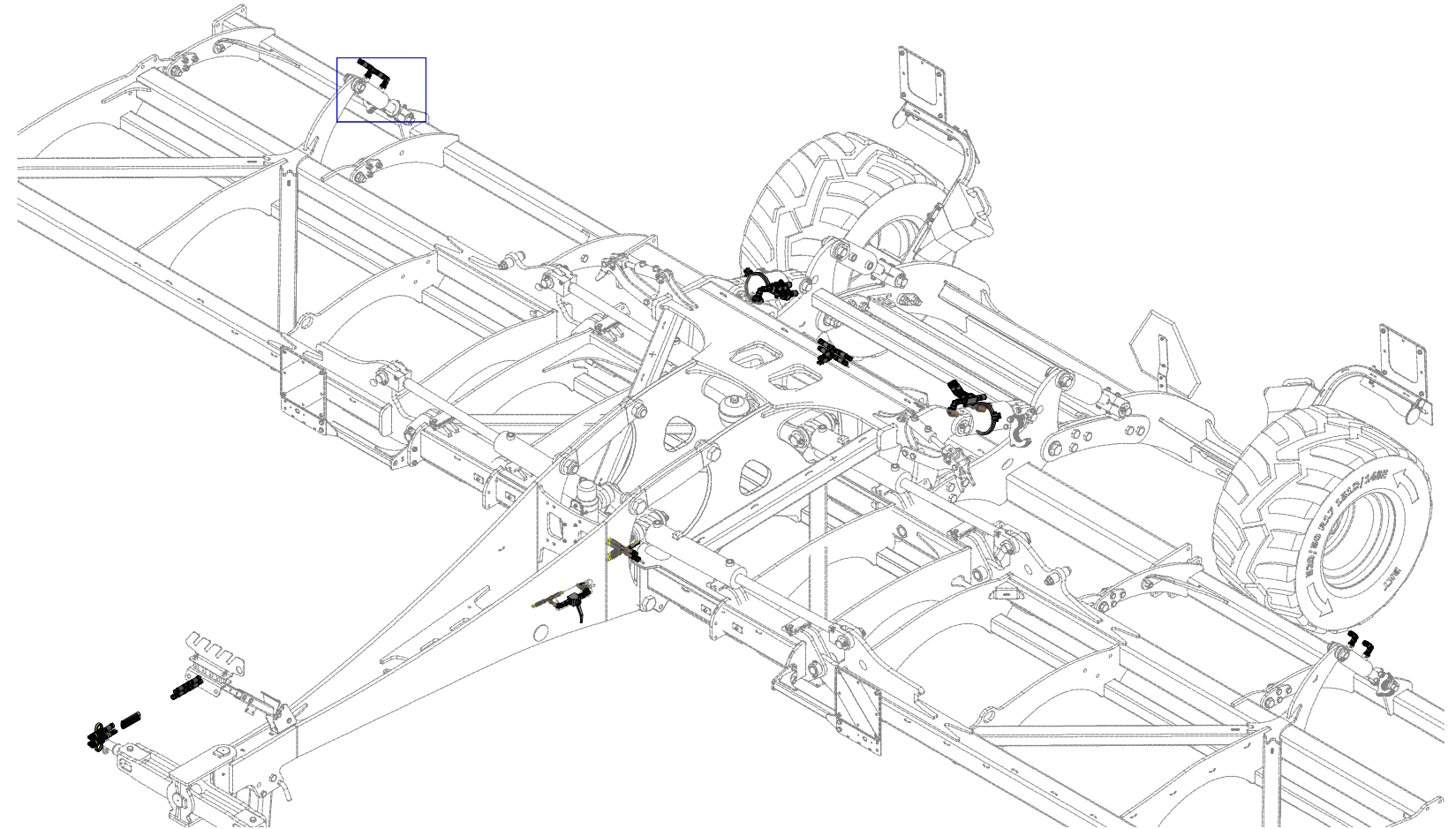
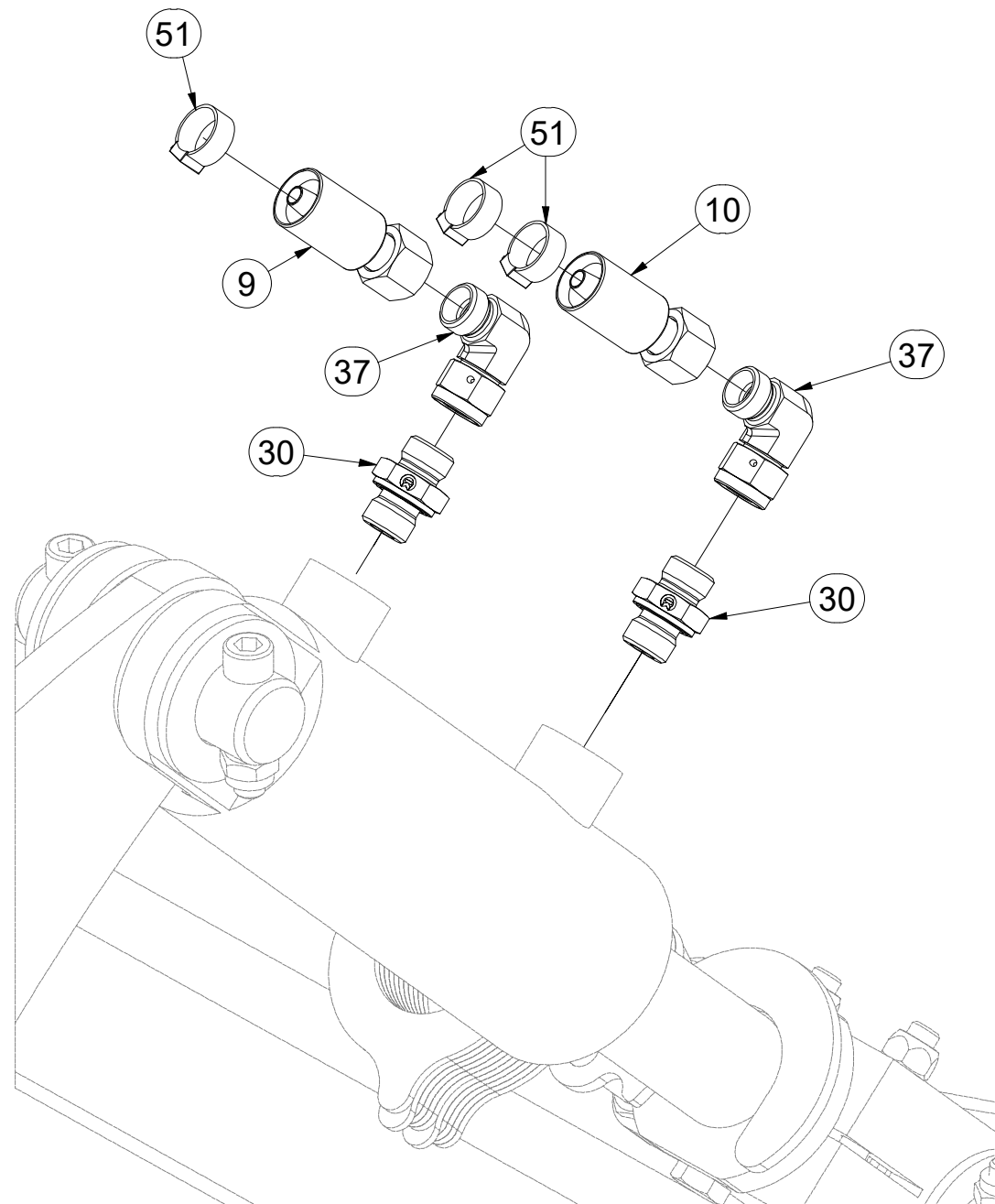

ⒸZ HYDRAULIKA STROJE

Ⓓ HYDRAULIK DER MASCHINE

Ⓕ HYDRAULIQUE DE LA MACHINE

ⒼB MACHINE HYDRAULICS

Ⓔ RU ГИДРАВЛИКА МАШИНЫ

Ⓗ PL HYDRAULIKA MASZYN



**VZ00020552**

Pos.	Part Number	Pcs.
9	m04666	2
10	m10020	2
30	m07906	4
37	m06803	9
51	m11289	46

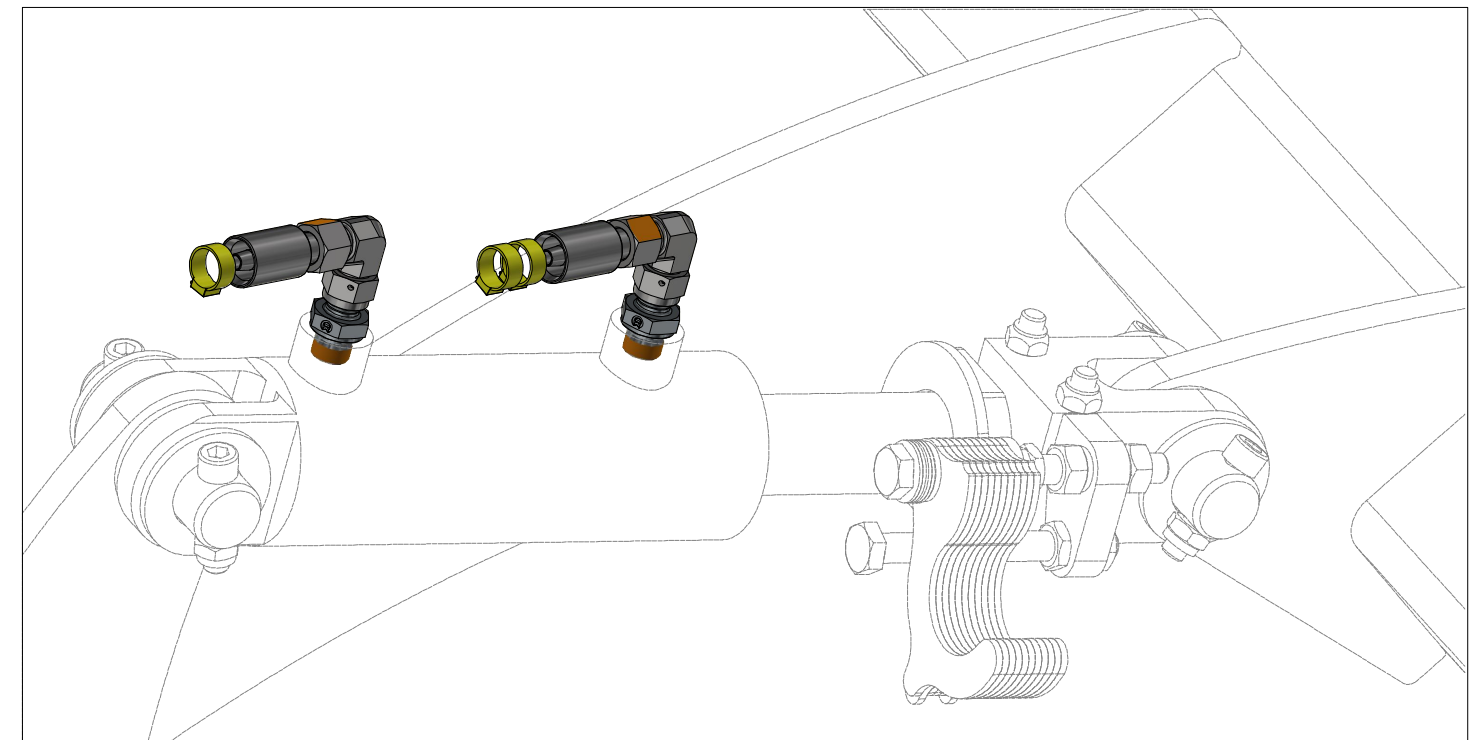
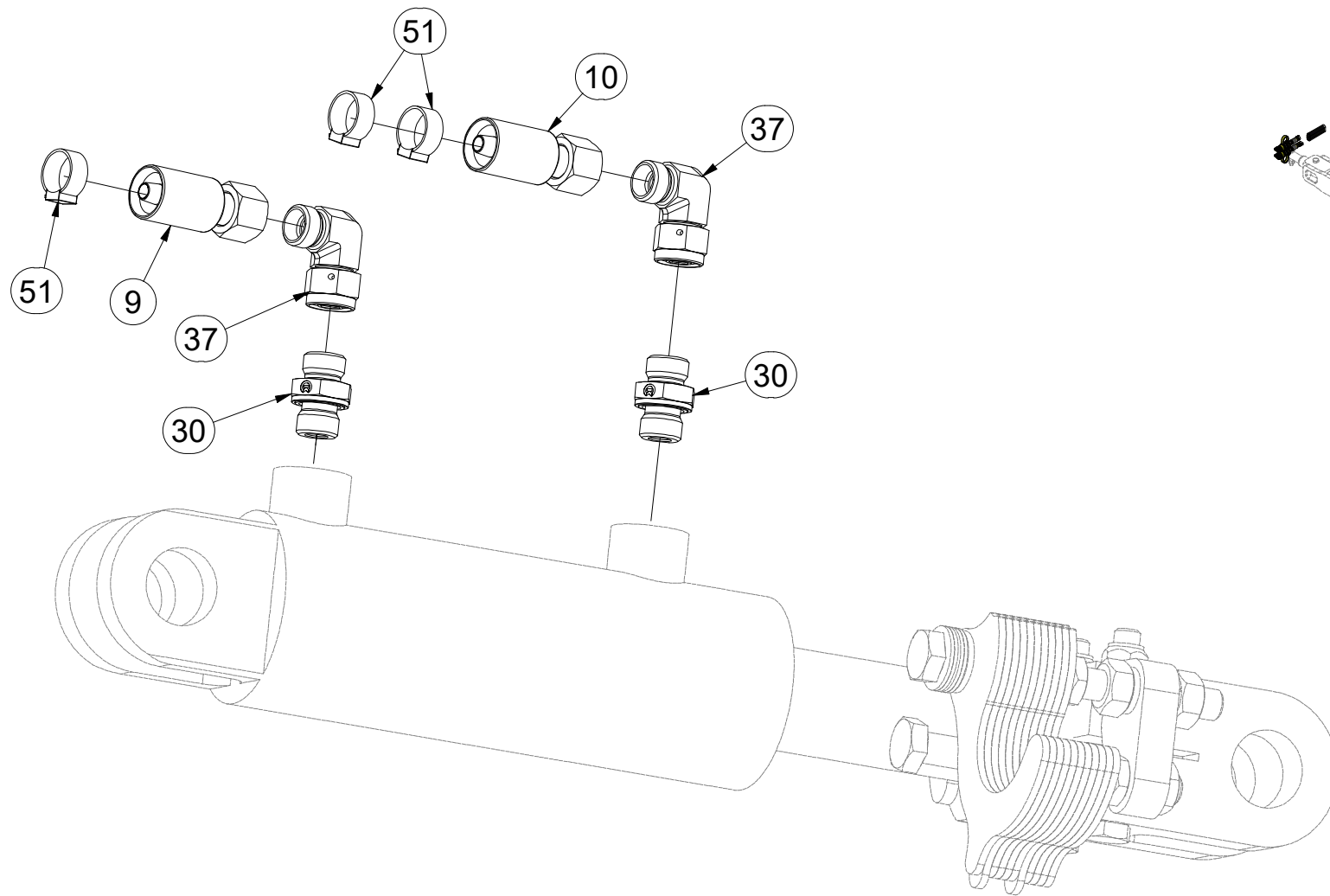
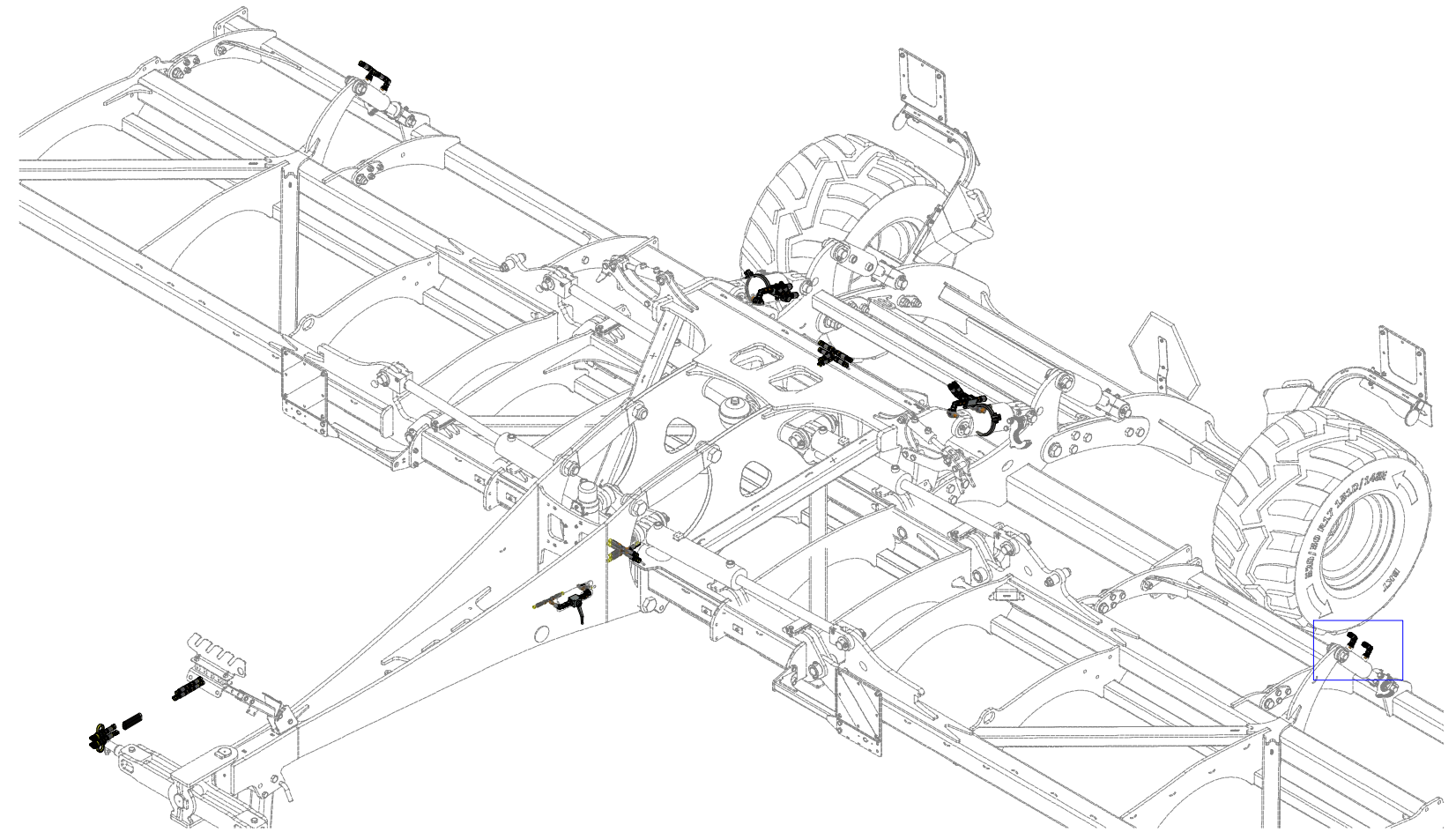

ⒸZ HYDRAULICKÝ ROZVOD NÁPRAVY

Ⓓ HYDRAULISCHE VERTEILUNG ACHSE

Ⓕ CONDUIT HYDRAULIQUE DE L'ESSIEU

ⒸGB HYDRAULIC AXLE DISTRIBUTION

ⒸRU ГИДРАВЛИЧЕСКОЕ РАСПРЕДЕЛЕНИЕ ОСИ

ⒸPL HYDRAULICZNY PRZEWÓD OSI

**Farmet**

**VZ00019487**

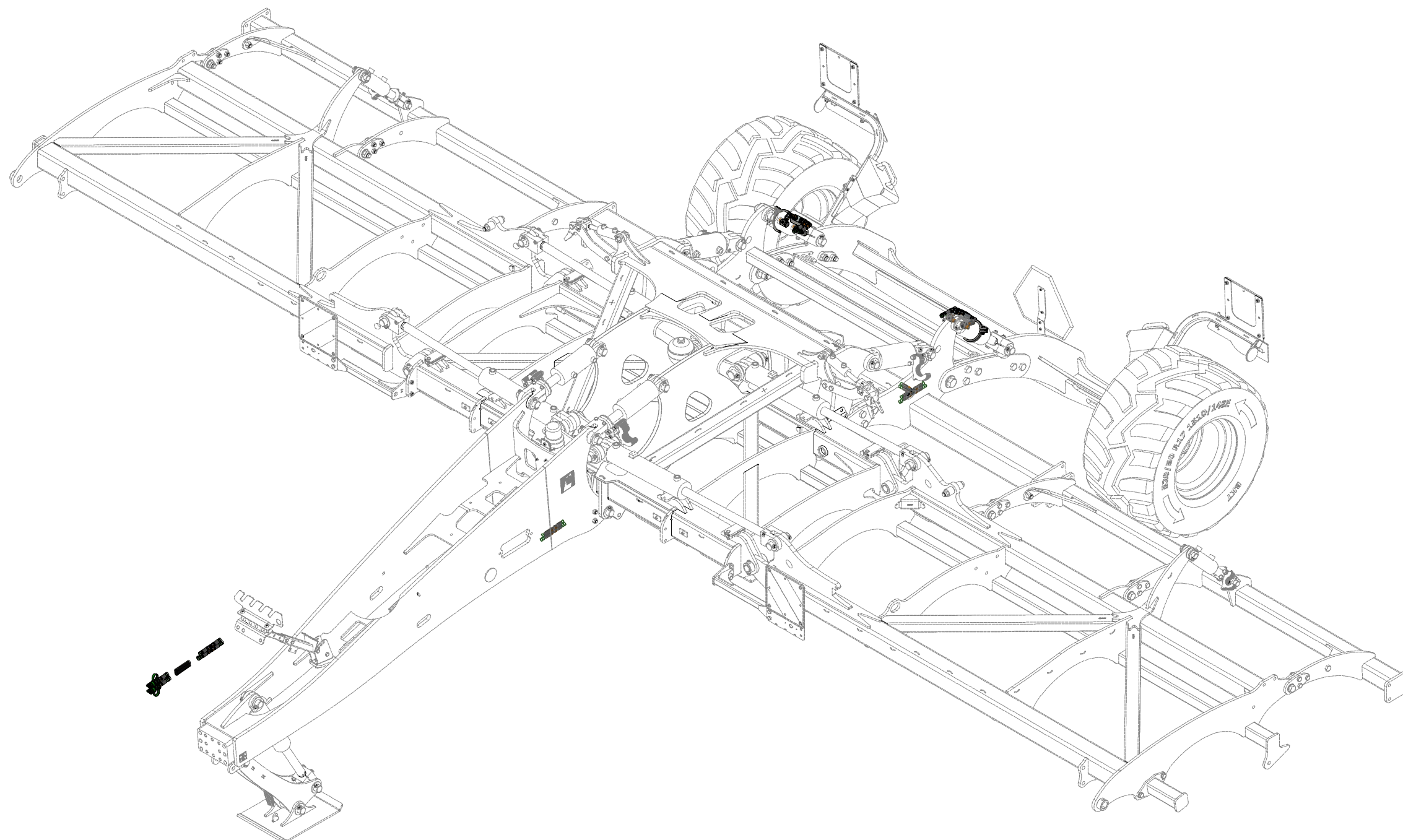



ⒸZ HYDRAULICKÝ ROZVOD NÁPRAVY

Ⓓ HYDRAULISCHE VERTEILUNG ACHSE

Ⓕ CONDUIT HYDRAULIQUE DE L'ESSIEU

ⒸB HYDRAULIC AXLE DISTRIBUTION

ⒸR ГИДРАВЛИЧЕСКОЕ РАСПРЕДЕЛЕНИЕ ОСИ

ⒸL HYDRAULICZNY PRZEWÓD OSI



VZ00019487

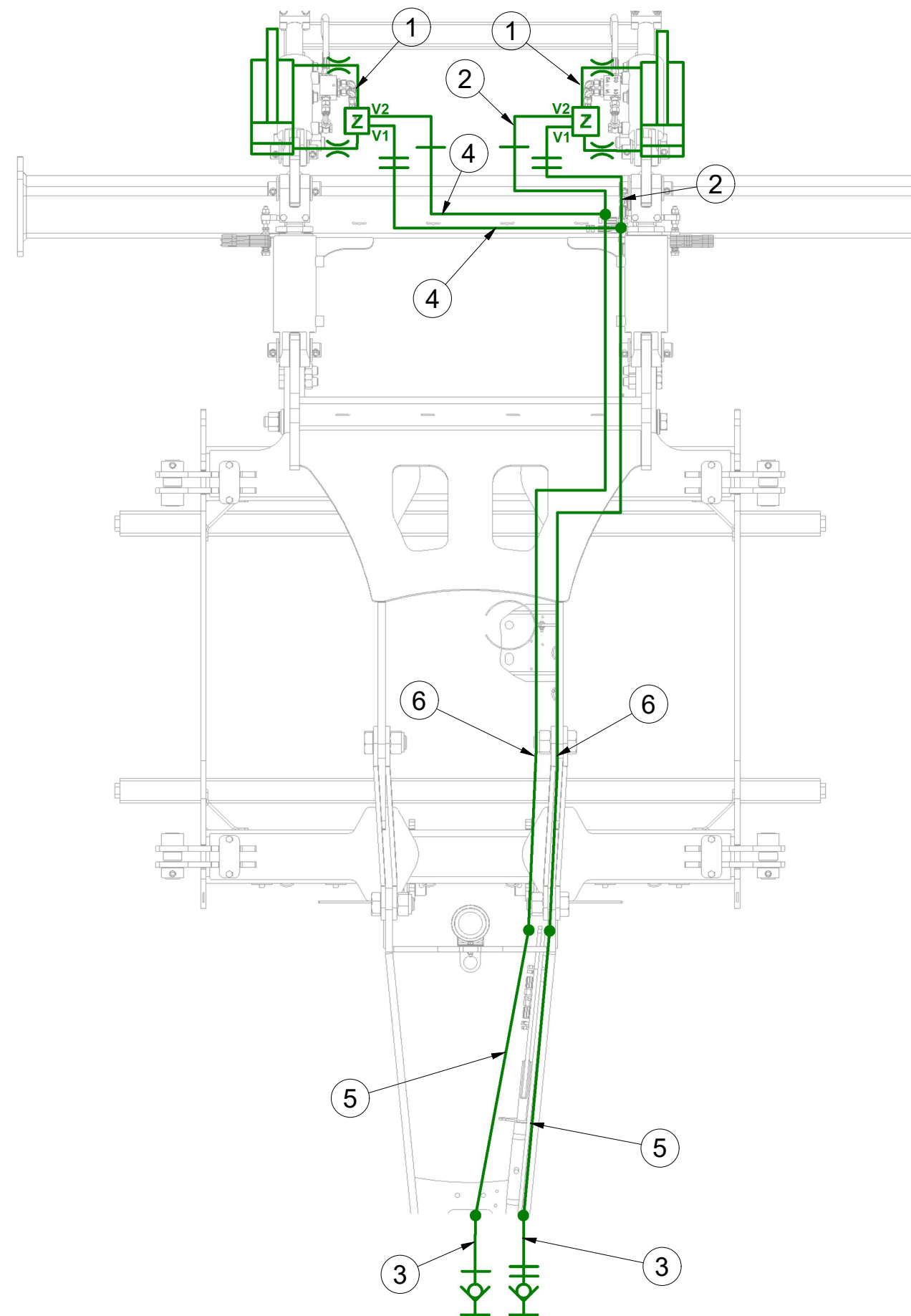

Pos.	Part Number	Pcs.
1	m03845	2
2	m04761	2
3	m11696	2
4	m03714	2
5	m16995	2
6	m04310	2

ⒸZ HYDRAULICKÝ ROZVOD NÁPRAVY

Ⓓ HYDRAULISCHE VERTEILUNG ACHSE

Ⓕ CONDUIT HYDRAULIQUE DE L'ESSIEU

ⒸB HYDRAULIC AXLE DISTRIBUTION

ⒸU ГИДРАВЛИЧЕСКОЕ РАСПРЕДЕЛЕНИЕ ОСИ

ⒸL HYDRAULICZNY PRZEWÓD OSI



VZ00019487

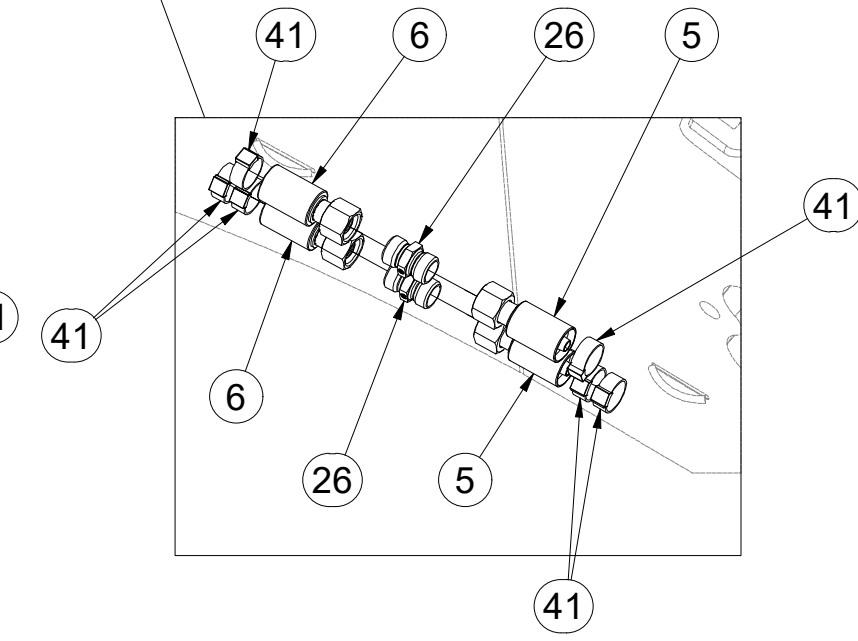
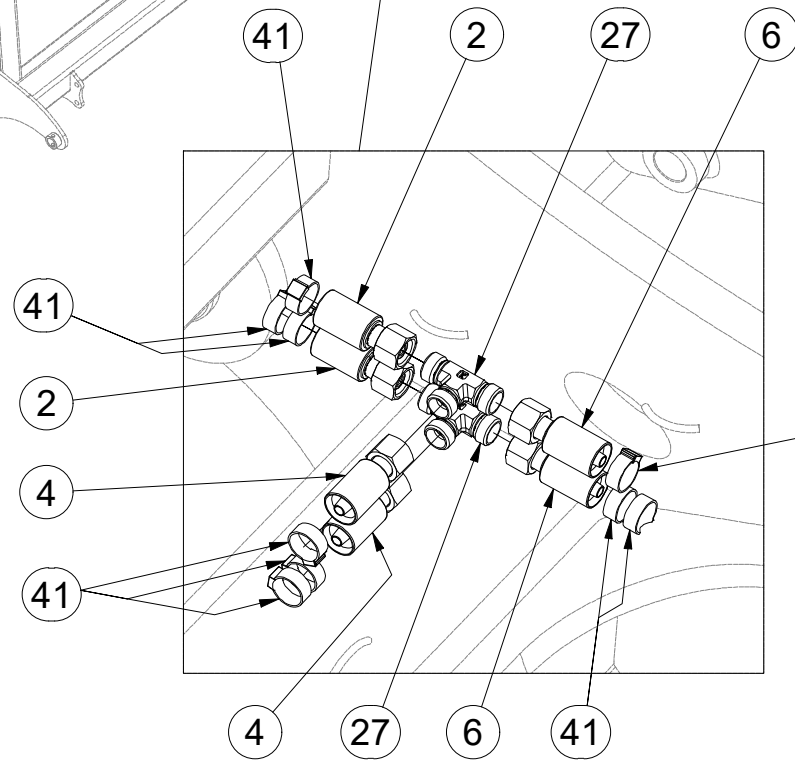
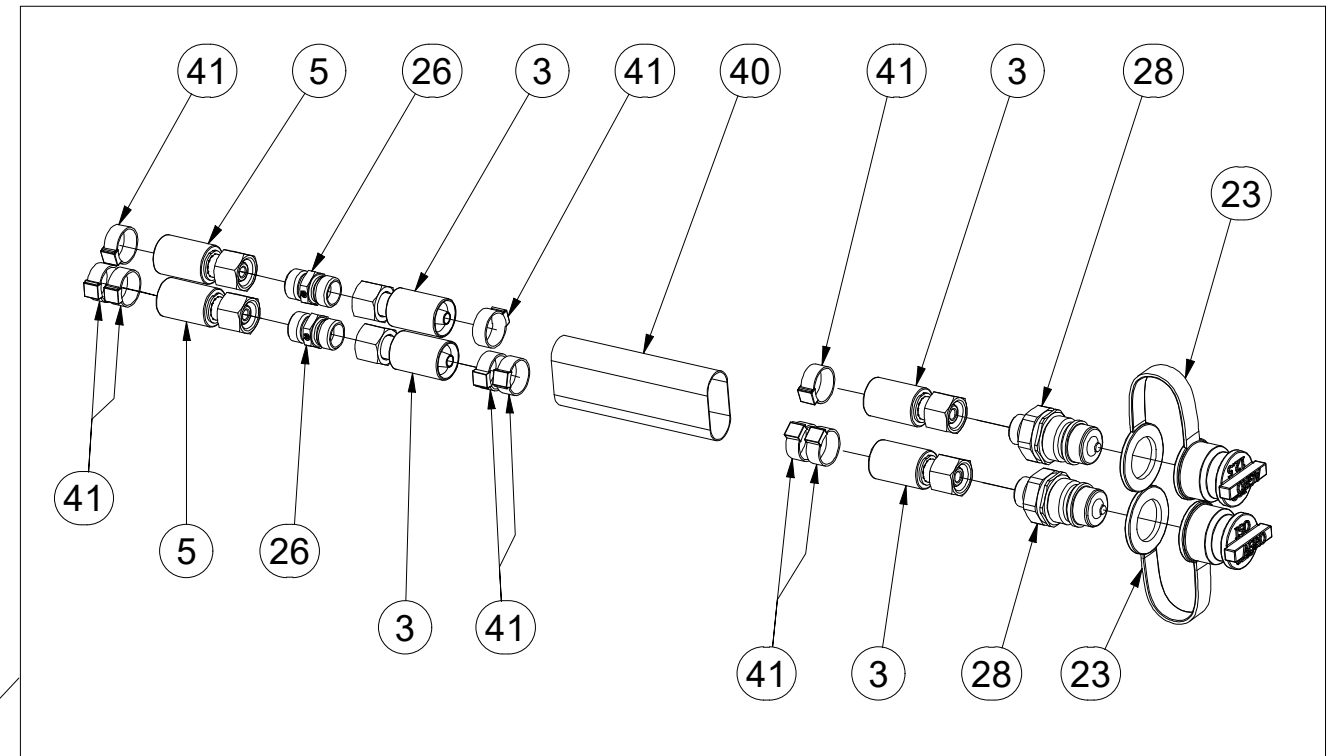
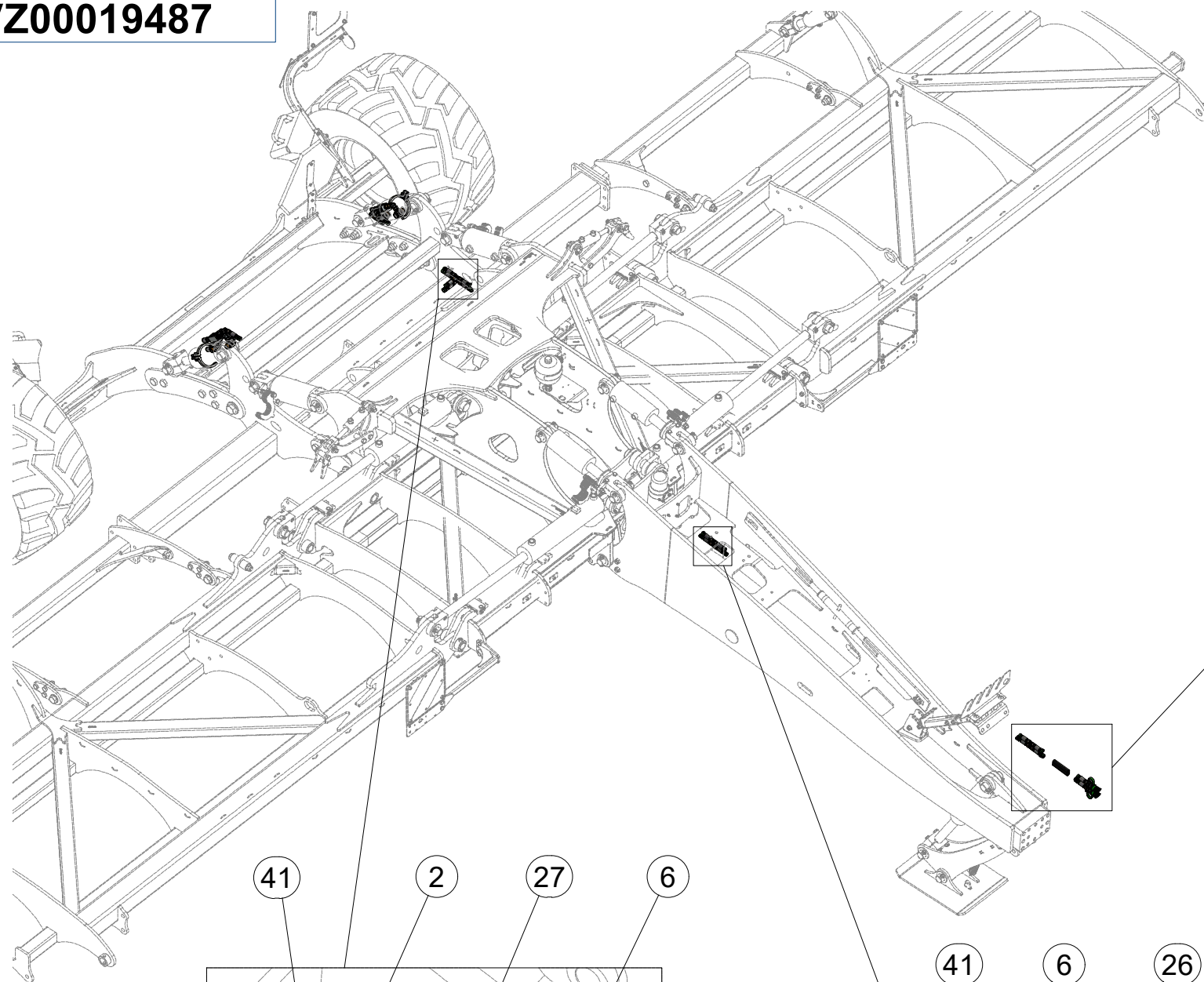

Pos.	Part Number	Pcs.
2	m04761	2
3	m11696	2
4	m03714	2
5	m16995	2
6	m04310	2
23	m04098	2
26	m03213	4
27	m03889	2
28	m03849	2
40	m11183	1
41	m11282	30

ⒸZ HYDRAULICKÝ ROZVOD NÁPRAVY

Ⓓ HYDRAULISCHE VERTEILUNG ACHSE

Ⓕ CONDUIT HYDRAULIQUE DE L'ESSIEU

**VZ00019487**

ⒸB HYDRAULIC AXLE DISTRIBUTION

Ⓔ ГИДРАВЛИЧЕСКОЕ РАСПРЕДЕЛЕНИЕ ОСИ

Ⓖ HYDRAULICZNY PRZEWÓD OSI

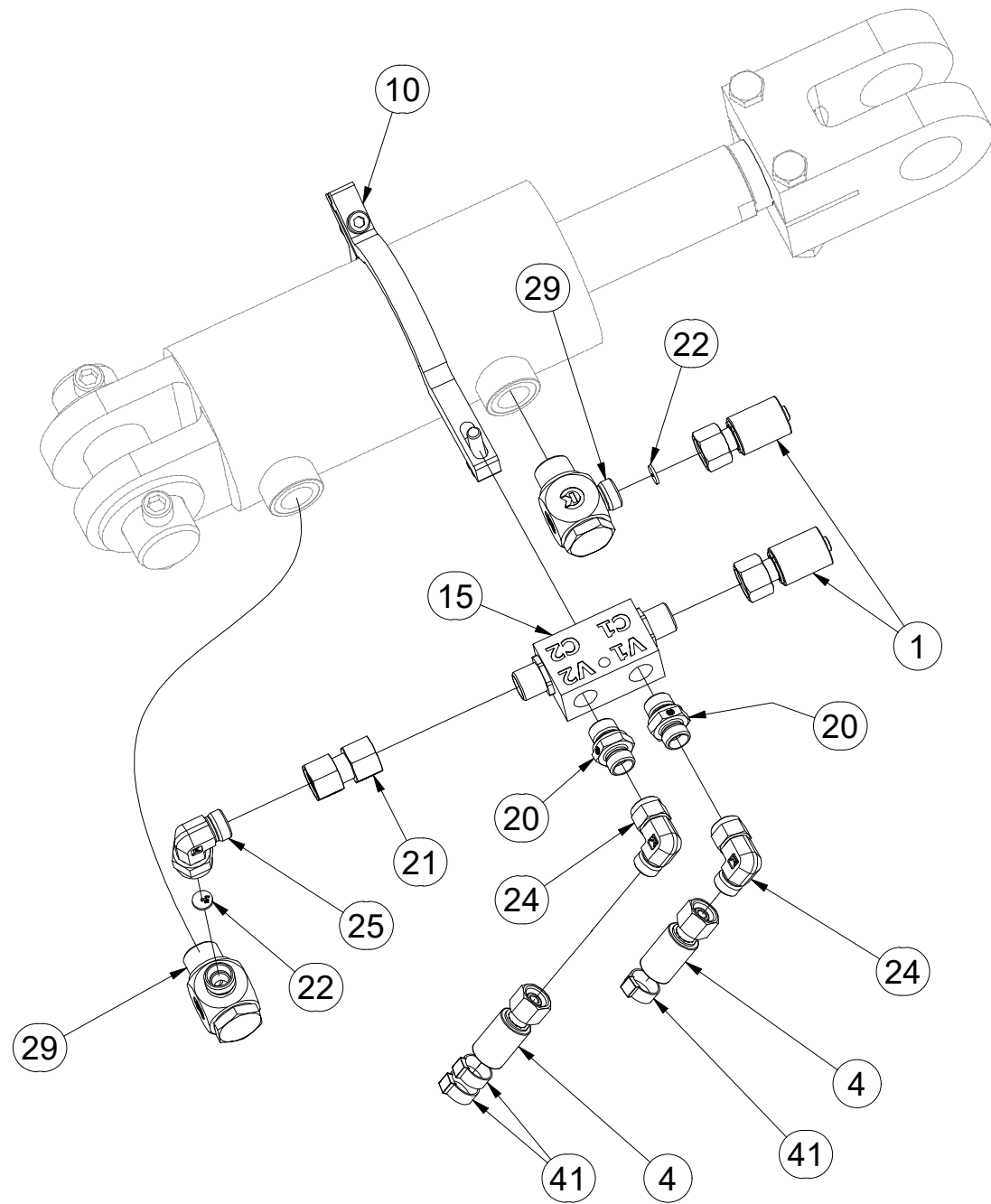

Pos.	Part Number	Pcs.
1	m03845	2
4	m03714	2
10	VZ00010409	2
15	m08083	2
20	m06528	4
21	m22306	2
22	m10762	4
24	m06803	4
25	m07654	2
29	m20912	4
41	m11282	30

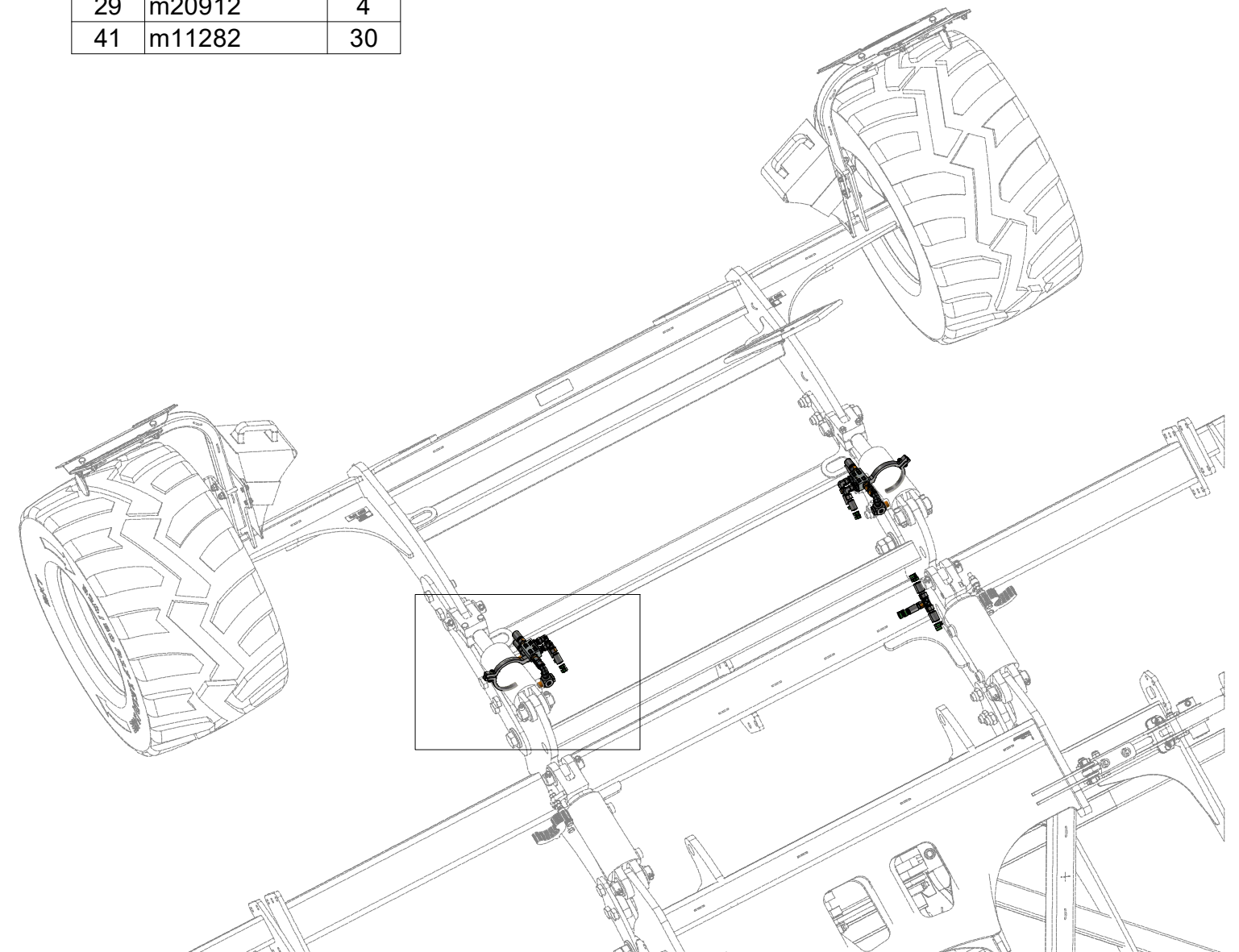

ⒸZ HYDRAULICKÝ ROZVOD NÁPRAVY

Ⓓ HYDRAULISCHE VERTEILUNG ACHSE

Ⓕ CONDUIT HYDRAULIQUE DE L'ESSIEU

ⒸB HYDRAULIC AXLE DISTRIBUTION

ⒸR ГИДРАВЛИЧЕСКОЕ РАСПРЕДЕЛЕНИЕ ОСИ

ⒸL HYDRAULICZNY PRZEWÓD OSI



**VZ00019487**

Pos.	Part Number	Pcs.
1	m03845	2
2	m04761	2
10	VZ00010409	2
15	m08083	2
20	m06528	4
21	m22306	2
22	m10762	4
24	m06803	4
25	m07654	2
29	m20912	4
41	m11282	30

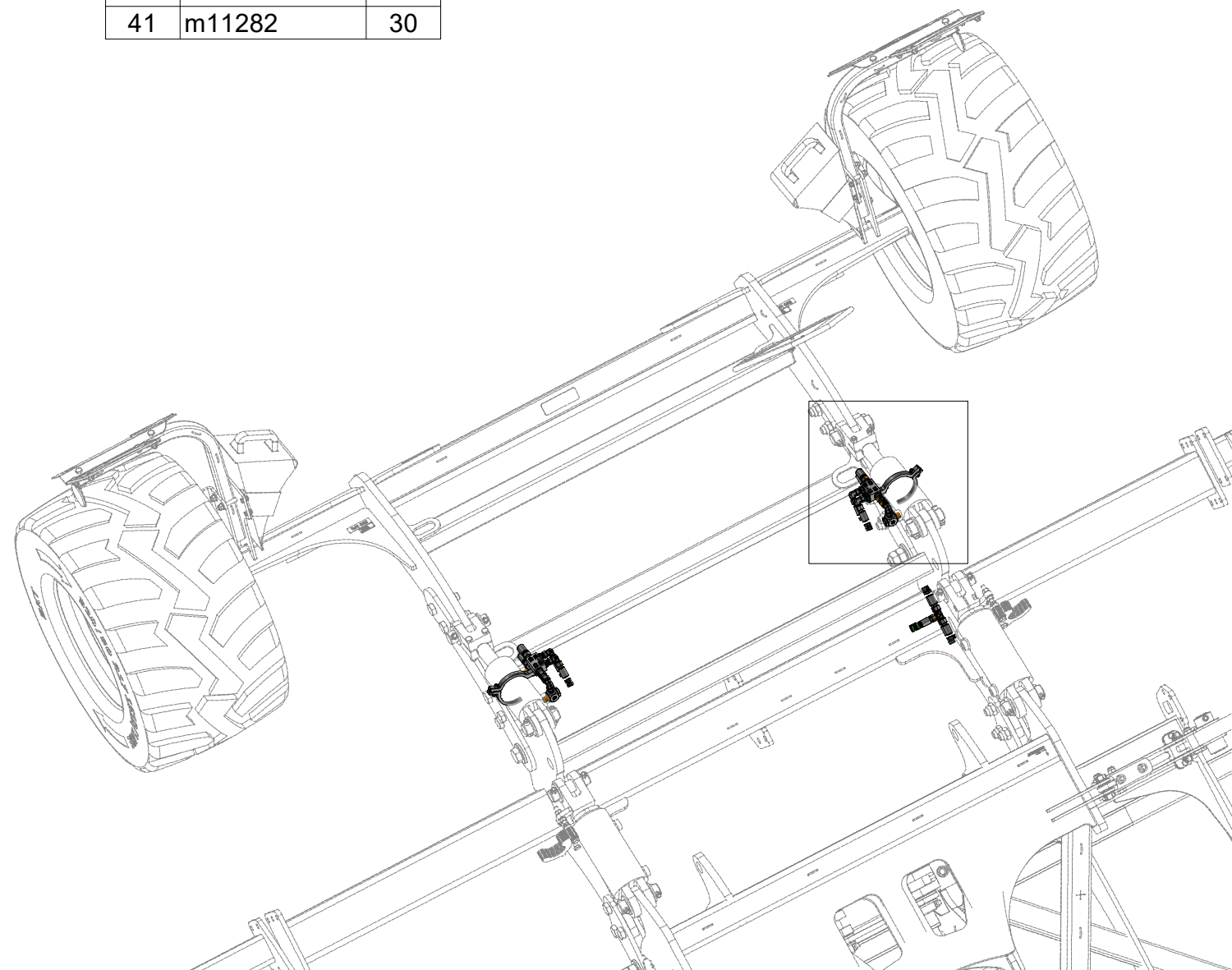
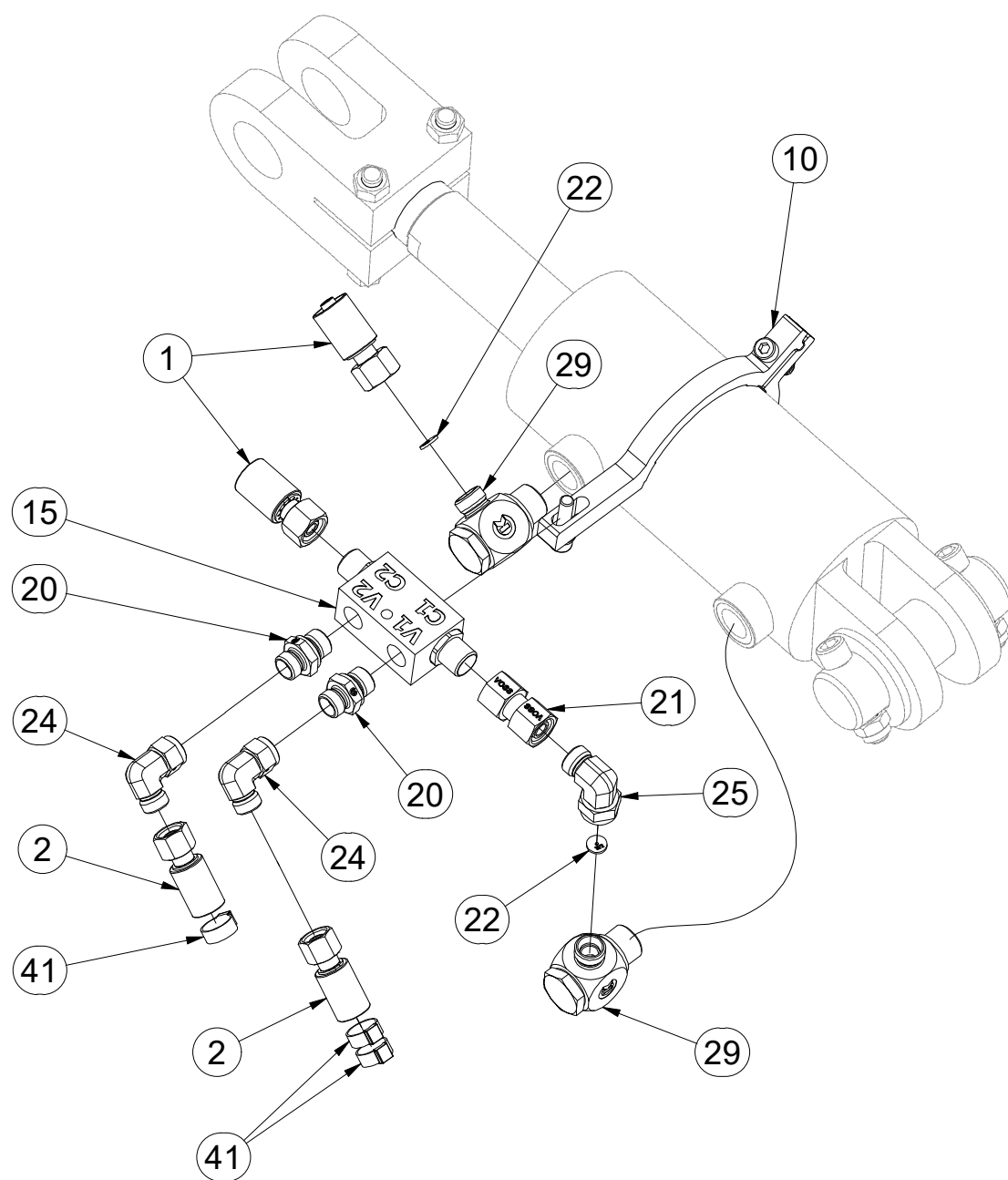

CZ DRŽÁK  
 D HALTER  
 F SUPPORT

GB HOLDER  
 RU ДЕРЖАТЕЛЬ  
 PL UCHWYT



**VZ00010112**

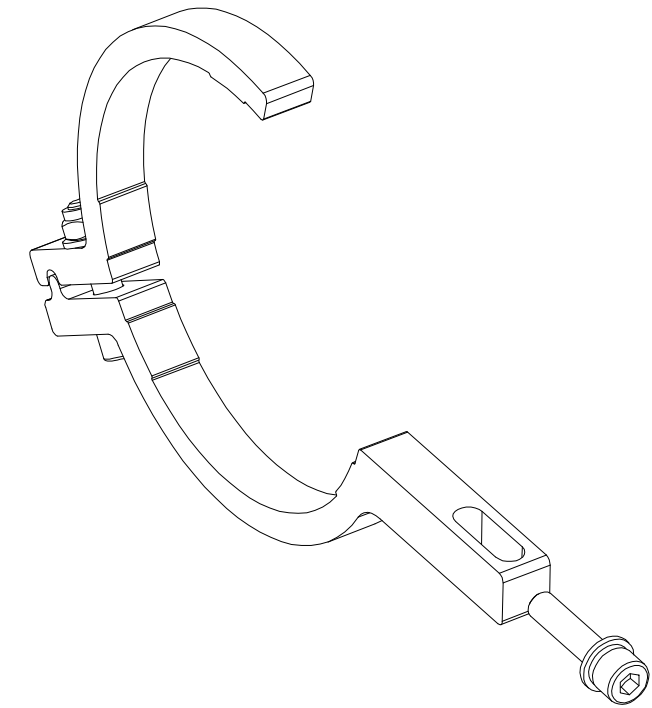
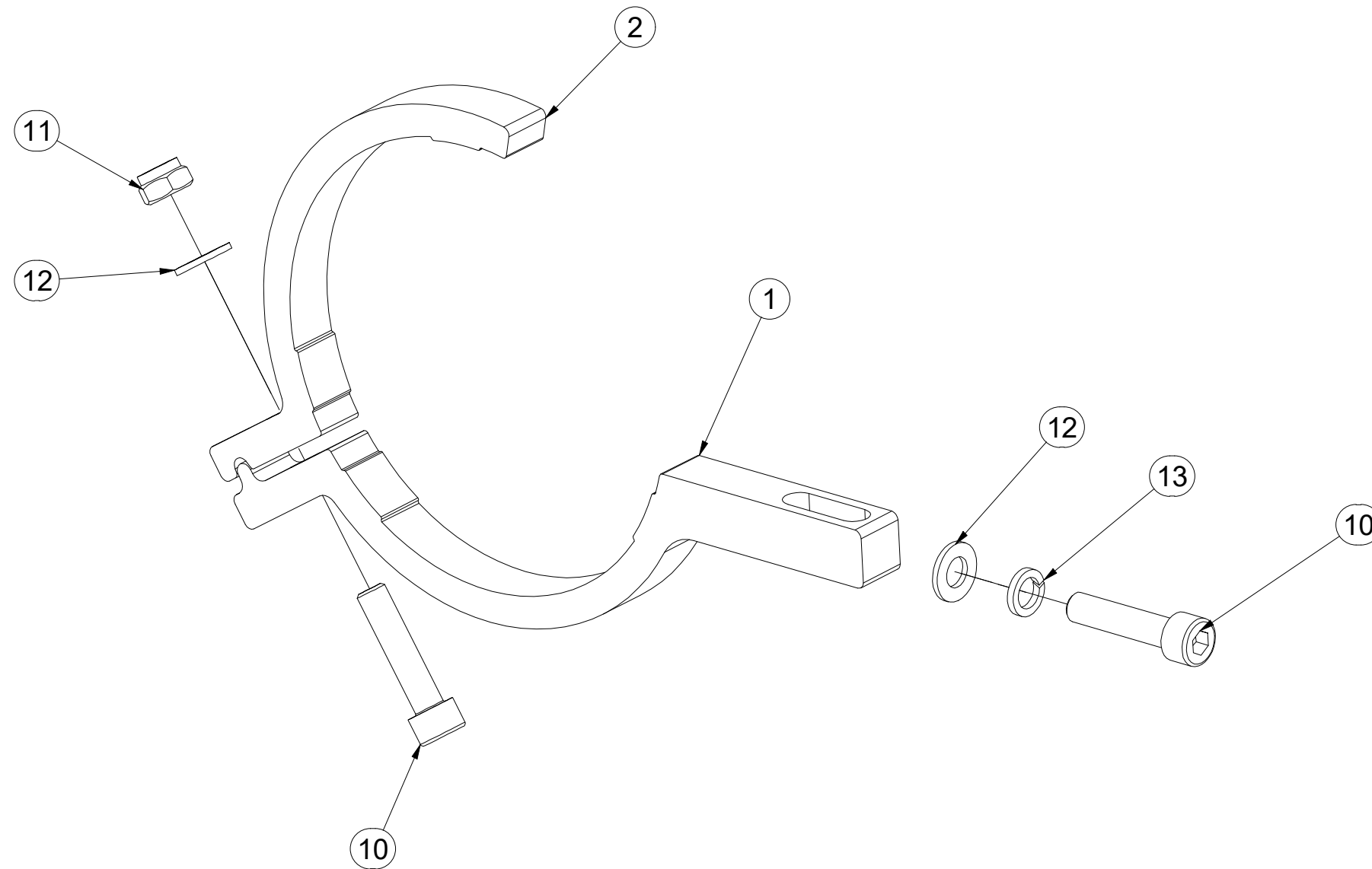

Pos.	Part Number	Pcs.
1	VZ00010113	1
2	VZ00010114	1
10	m09464	2
11	m04503	1
12	m01203	2
13	m01202	1

- ⒸZ DRŽÁK
- Ⓓ HALTER
- Ⓕ SUPPORT

- ⒼB HOLDER
- ⒶRU ДЕРЖАТЕЛЬ
- ⒶPL UCHWYT



**VZ00010409**

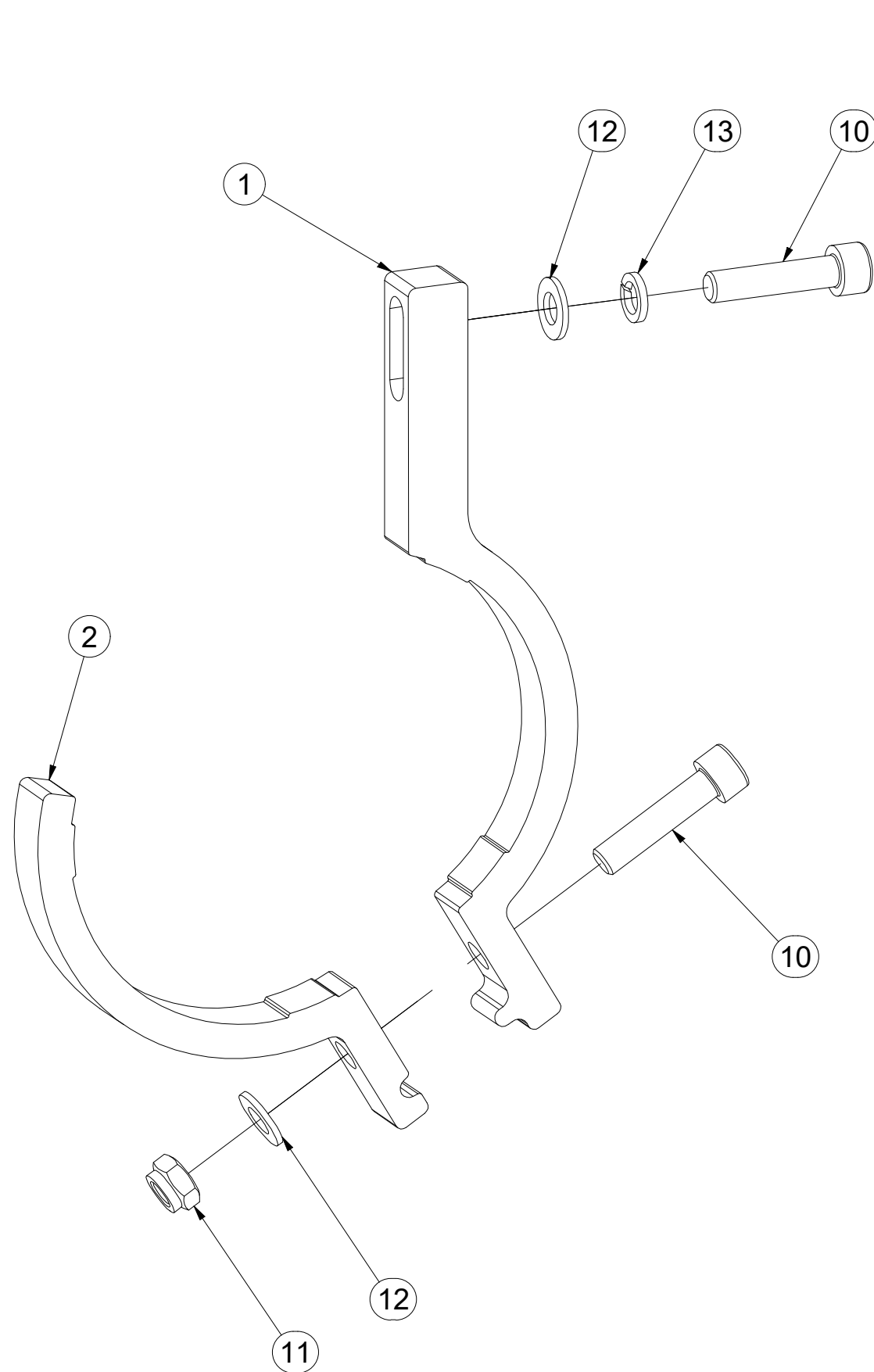

Pos.	Part Number	Pcs.
1	VZ00010410	1
2	VZ00010408	1
10	m09464	2
11	m04503	1
12	m01203	2
13	m01202	1

Ⓒ PÍSTNICE 110/56-100

Ⓓ KOLBENSTANGE 110/56-100

Ⓕ TIGE DE PISTON 110/56-100

Ⓖ PISTON ROD 110/56-100

Ⓡ ЦИЛИНДР 110/56-100

Ⓟ TRZPIEŃ TŁOKA 110/56-100



**VZ00011042**

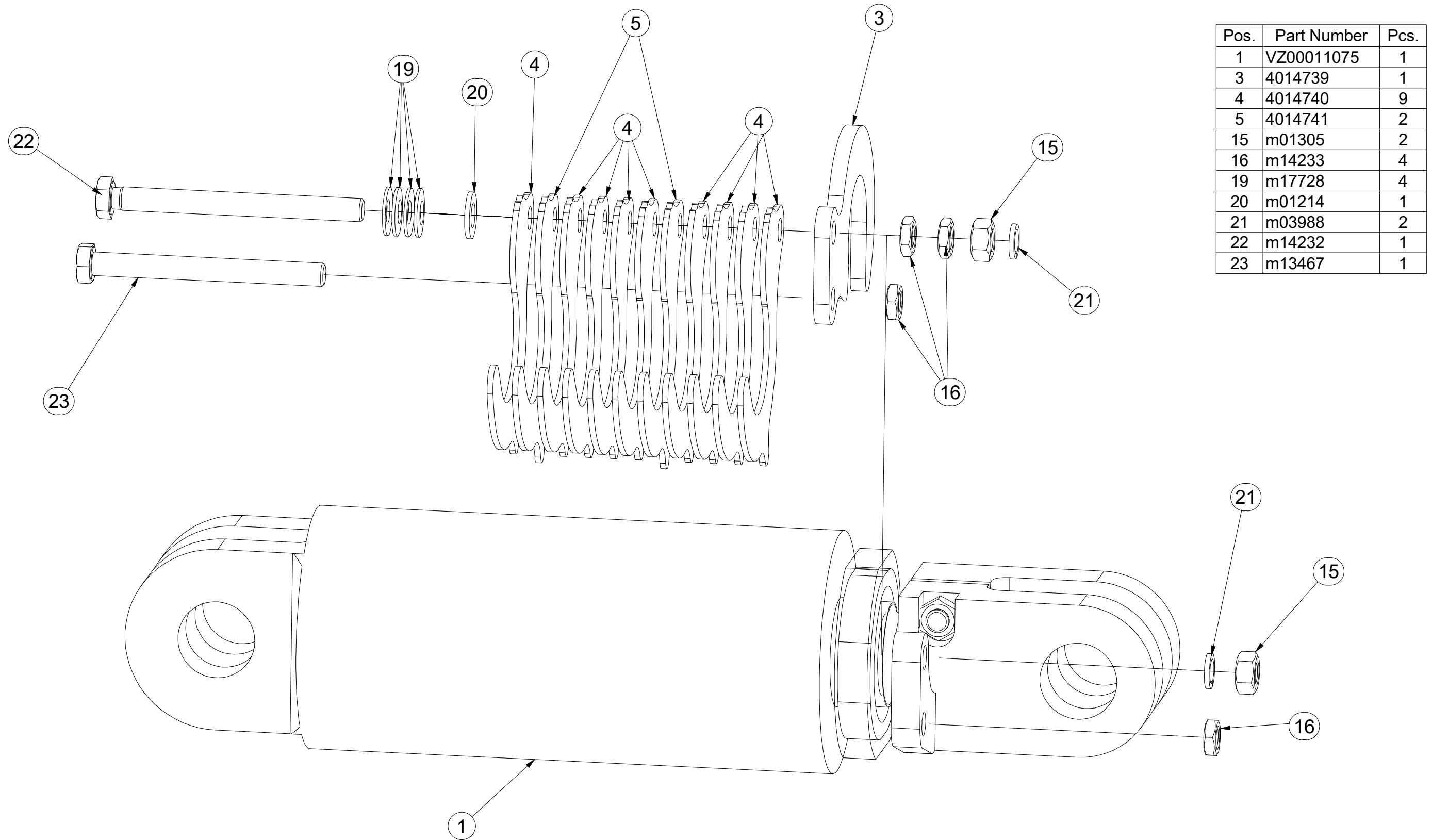

Pos.	Part Number	Pcs.
1	VZ00011075	1
3	4014739	1
4	4014740	9
5	4014741	2
15	m01305	2
16	m14233	4
19	m17728	4
20	m01214	1
21	m03988	2
22	m14232	1
23	m13467	1

Ⓒ PÍSTNICE 63/40-95

Ⓓ KOLBENSTANGE 63/40-95

Ⓕ TIGE DE PISTON 63/40-95

Ⓖ PISTON ROD 63/40-95

Ⓙ ЦИЛИНДР 63/40-95

Ⓟ TRZPIEŃ TŁOKA 63/40-95



**4015781**

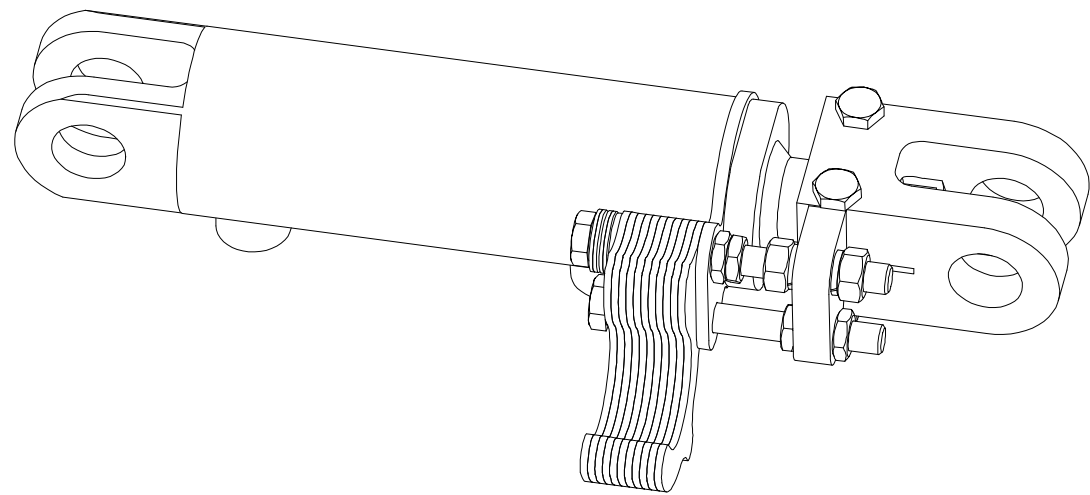
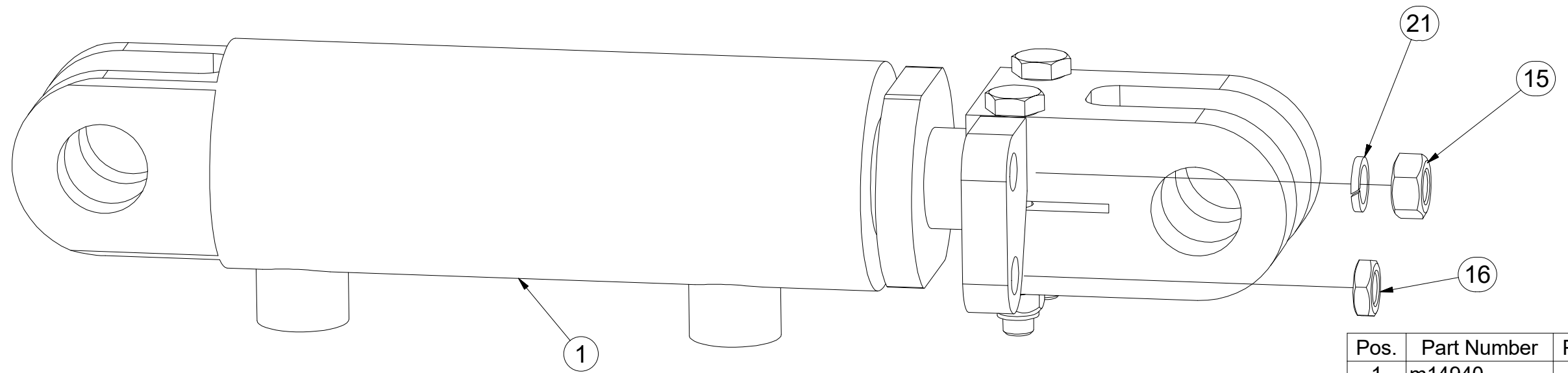
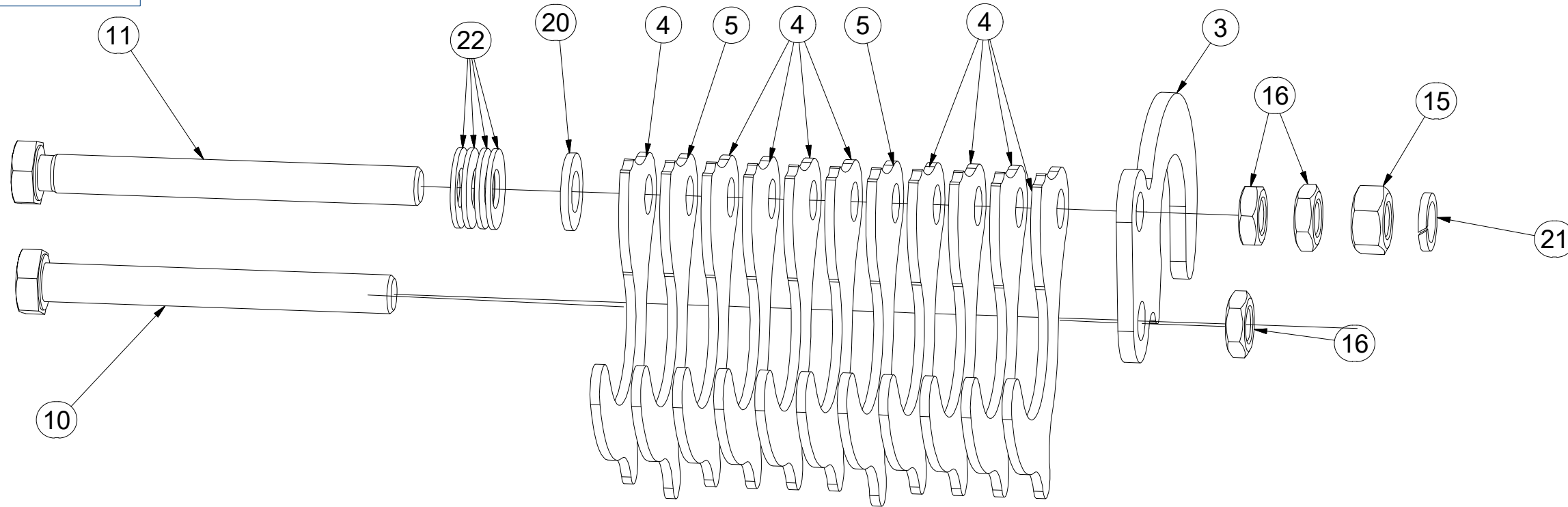

Pos.	Part Number	Pcs.
1	m14940	1
3	4013741	1
4	4013739	9
5	4013740	2
10	m03927	1
11	m11148	1
15	m01305	2
16	m14233	4
20	m01214	1
21	m03988	2
22	m17728	4



Ⓒ PÍSTNICE 110/56-100

Ⓓ KOLBENSTANGE 110/56-100

Ⓕ TIGE DE PISTON 110/56-100

Ⓖ PISTON ROD 110/56-100

Ⓡ ЦИЛИНДР 110/56-100

Ⓟ TRZPIEŃ TŁOKA 110/56-100

**Farmet**

**VZ00011075**

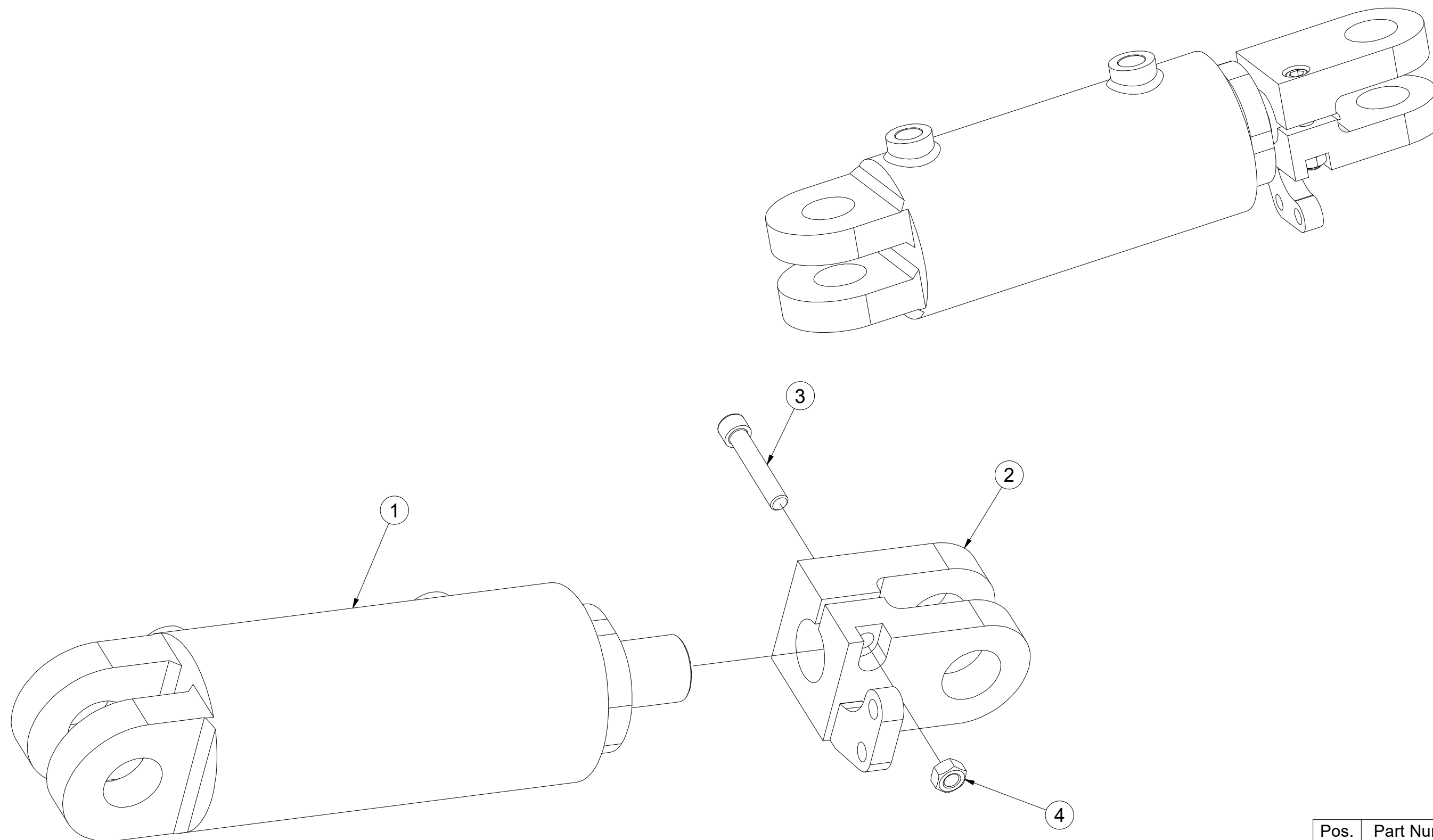

Pos.	Part Number	Pcs.
1	m21020	1
2	m20347	1
3	m14867	1
4	m10439	1

Ⓒ PÍSTNICE 110/56-100

Ⓓ KOLBENSTANGE 110/56-100

Ⓕ TIGE DE PISTON 110/56-100

Ⓖ PISTON ROD 110/56-100

Ⓡ ЦИЛИНДР 110/56-100

Ⓟ TRZPIEŃ TŁOKA 110/56-100



VZ00011113

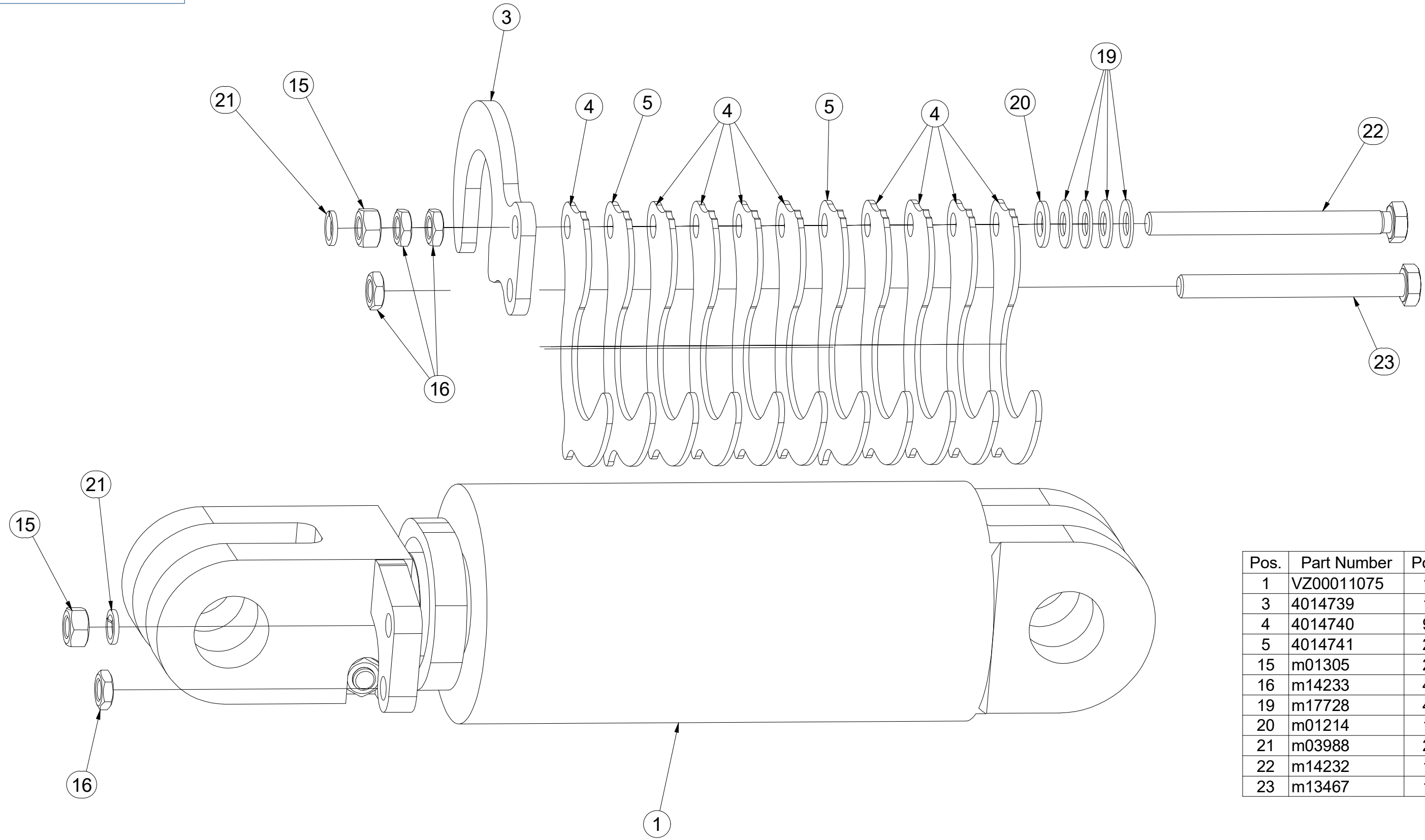

Pos.	Part Number	Pcs.
1	VZ00011075	1
3	4014739	1
4	4014740	9
5	4014741	2
15	m01305	2
16	m14233	4
19	m17728	4
20	m01214	1
21	m03988	2
22	m14232	1
23	m13467	1

Ⓒ SOUPRAVA TĚSNIVA PÍSTNIC

Ⓓ KOLBENSTANGENDICHTUNGSMITTELSATZ

Ⓕ SET DE GARNITURE DES TIGES DE PISTON

Ⓖ SEALING SET FOR PISTON RODS

Ⓔ КОМПЛЕКТ ПРОКЛАДОК ЦИЛИНДРОВ

Ⓗ ZESTAW USZCZELEK TRZPIENIA TŁOKA

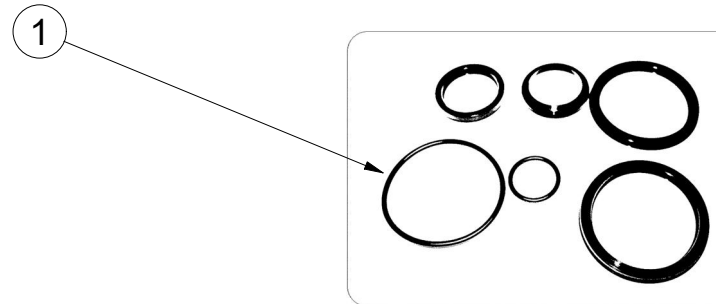
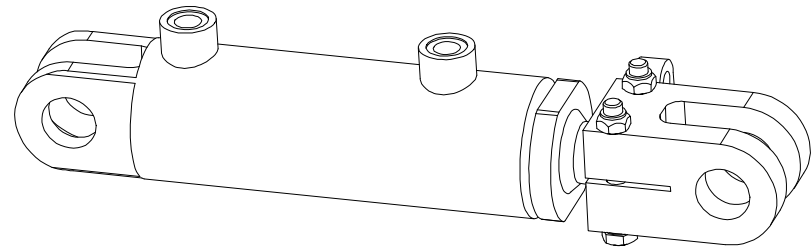

m14940 - $\varnothing 63/\varnothing 40-95$		
Pos	Part number	Pcs
1	m15372	2

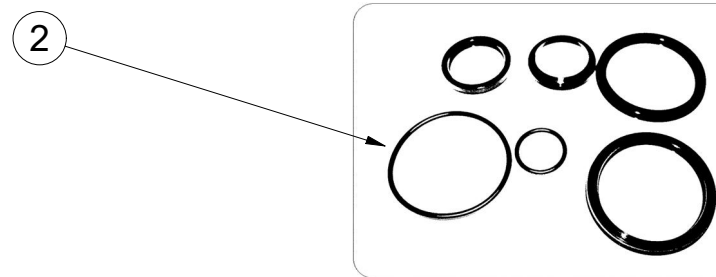
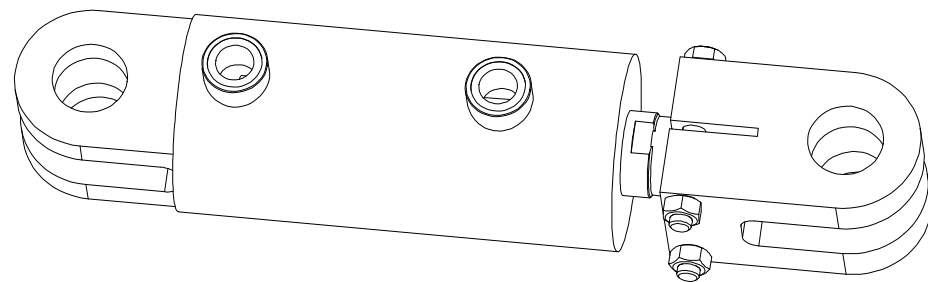

m17172 - $\varnothing 90/\varnothing 45-100$		
Pos	Part number	Pcs
2	m15374	2

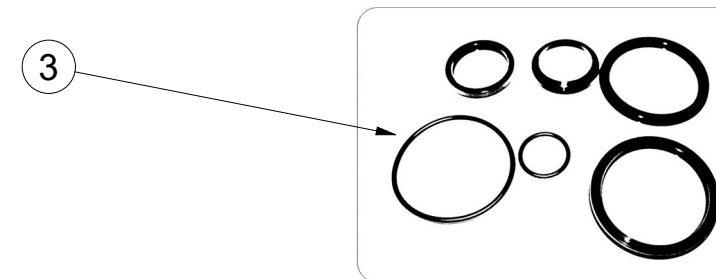
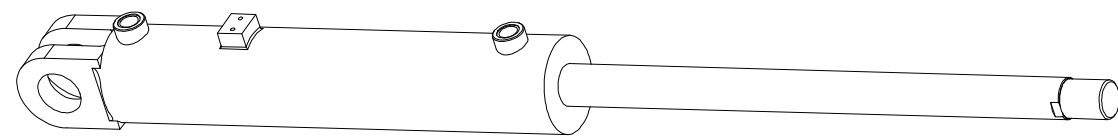

m21533 - $\varnothing 90/\varnothing 45-415$		
Pos	Part number	Pcs
3		4

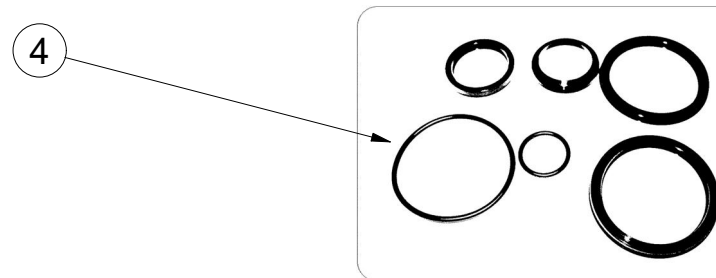
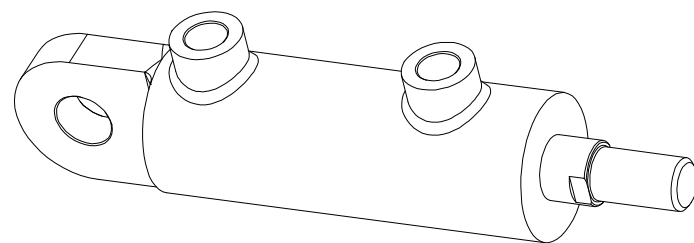

m20711 - $\varnothing 40/\varnothing 22-63$		
Pos	Part number	Pcs
4		2

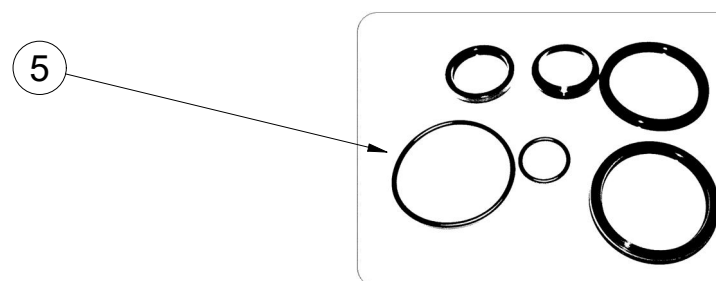
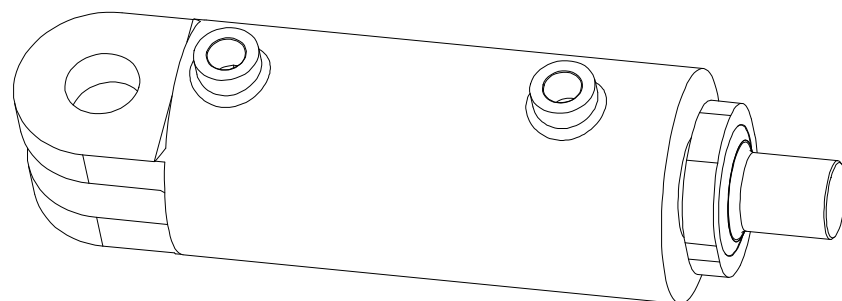

m21020 - $\varnothing 110/\varnothing 56-100$		
Pos	Part number	Pcs
5	m15376	2

☉ SAMOLEPKY STROJE

☉ AUFKLEBER MASCHINEN

☉ VOITURE MACHINES

☉ STICKERS MACHINES

☉ СТИКЕРЫ МАШИНЫ

☉ NAKLEJKI MASZYNY



**m19523**

Pos.	Part Number	Pcs.	Pos.	Part Number	Pcs.
1	m19521	6	15	m03320	1
3	m13102	1	17	m04368	4
5	m10353	2	20	m11297	8
7	m14958	3	21	m11296	2
8	m11147	4	22	m11295	1
10	m13117	2	23	m17300	1
11	m13116	5			

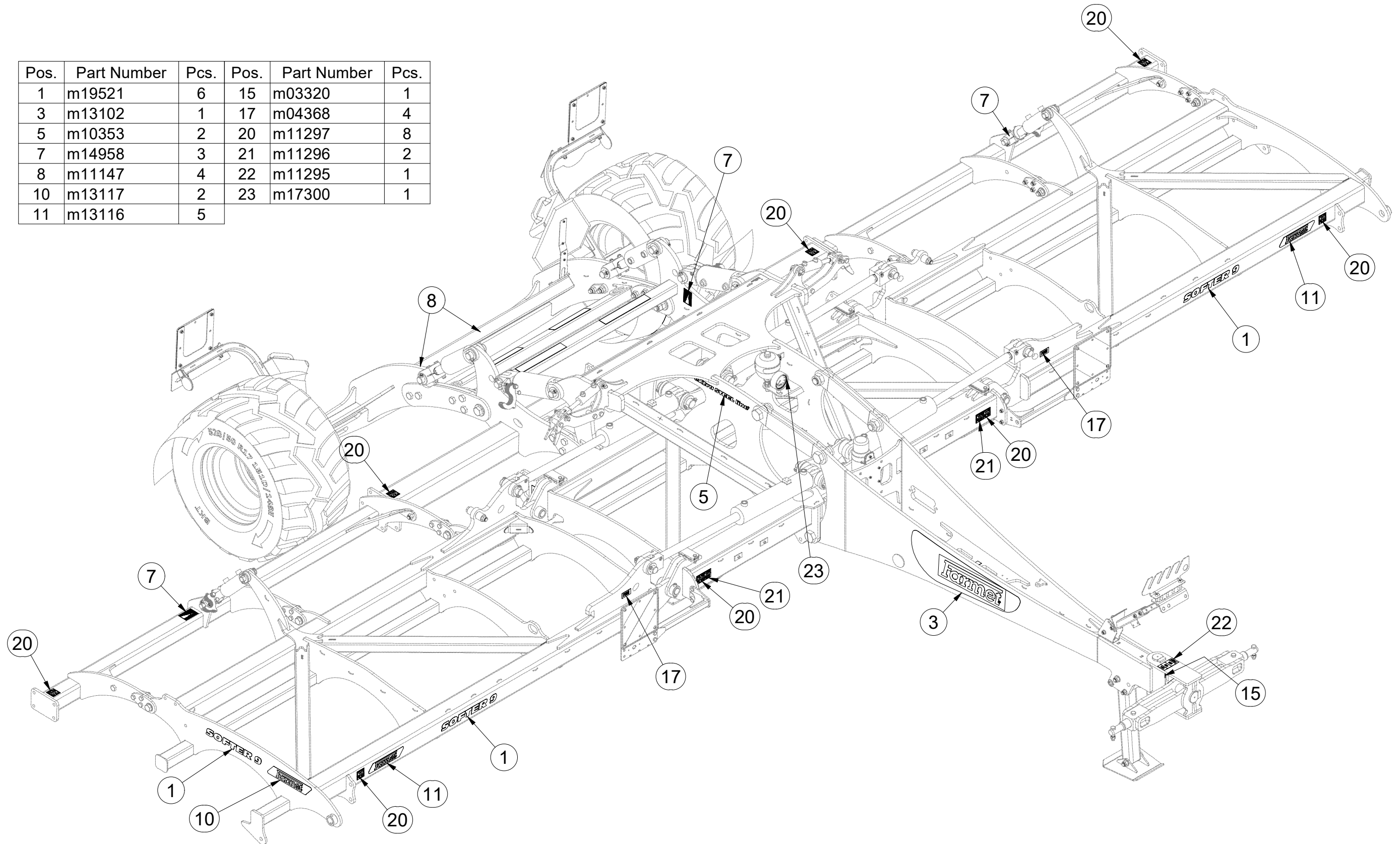

☉ SAMOLEPKY STROJE

☉ AUFKLEBER MASCHINEN

☉ VOITURE MACHINES

☉ STICKERS MACHINES

☉ СТИКЕРЫ МАШИНЫ

☉ NAKLEJKI MASZYNY



**m19523**

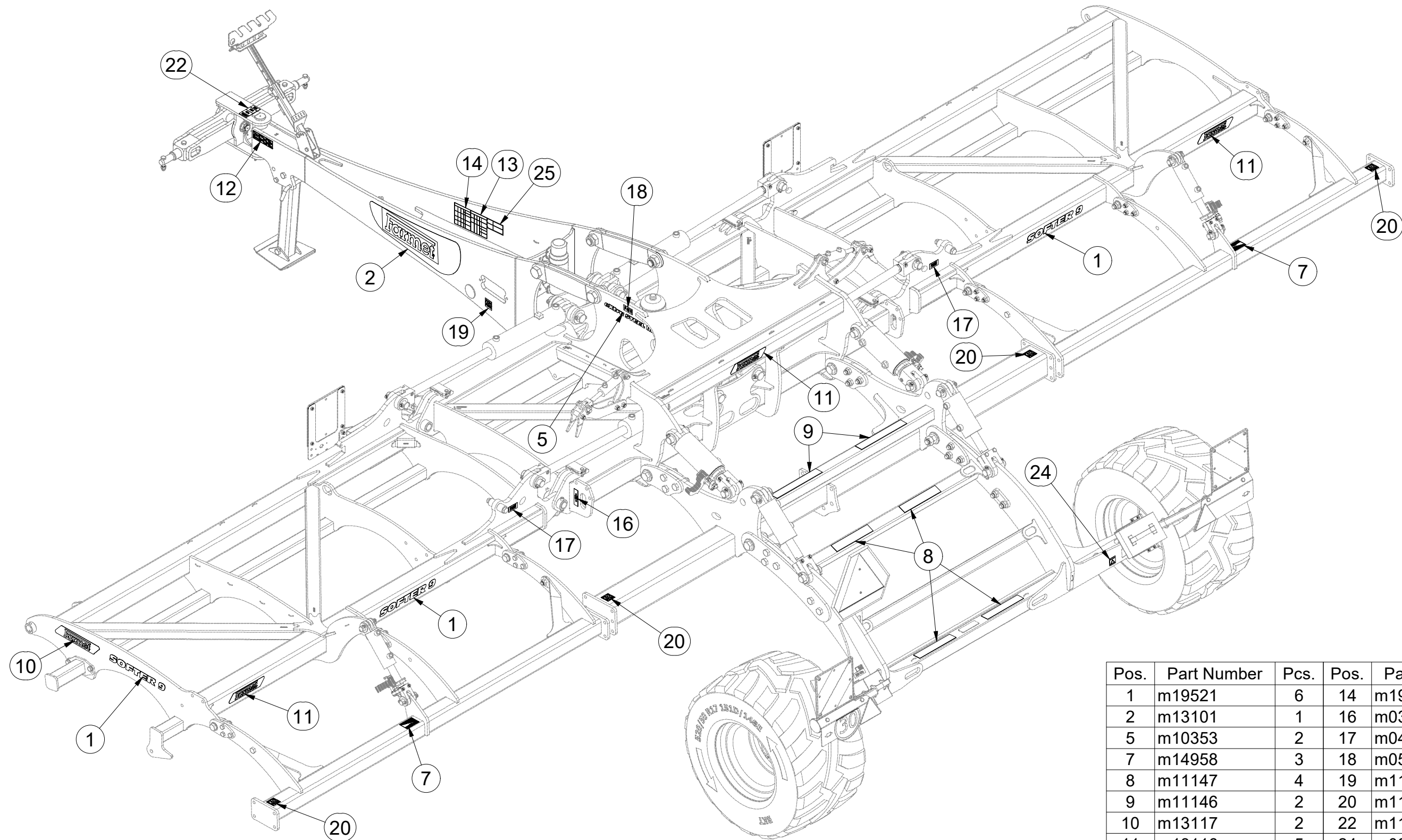

Pos.	Part Number	Pcs.	Pos.	Part Number	Pcs.
1	m19521	6	14	m19532	1
2	m13101	1	16	m03316	3
5	m10353	2	17	m04368	4
7	m14958	3	18	m05312	1
8	m11147	4	19	m11299	1
9	m11146	2	20	m11297	8
10	m13117	2	22	m11295	1
11	m13116	5	24	m03512	2
12	m21969	1	25	m19533	1
13	m19531	1			

Ⓒ SAMOLEPKY STROJE

Ⓓ AUFKLEBER MASCHINEN

Ⓕ VOITURE MACHINES

Ⓖ STICKERS MACHINES

Ⓡ СТИКЕРЫ МАШИНЫ

Ⓟ NAKLEJKI MASZYNY



**4025230**

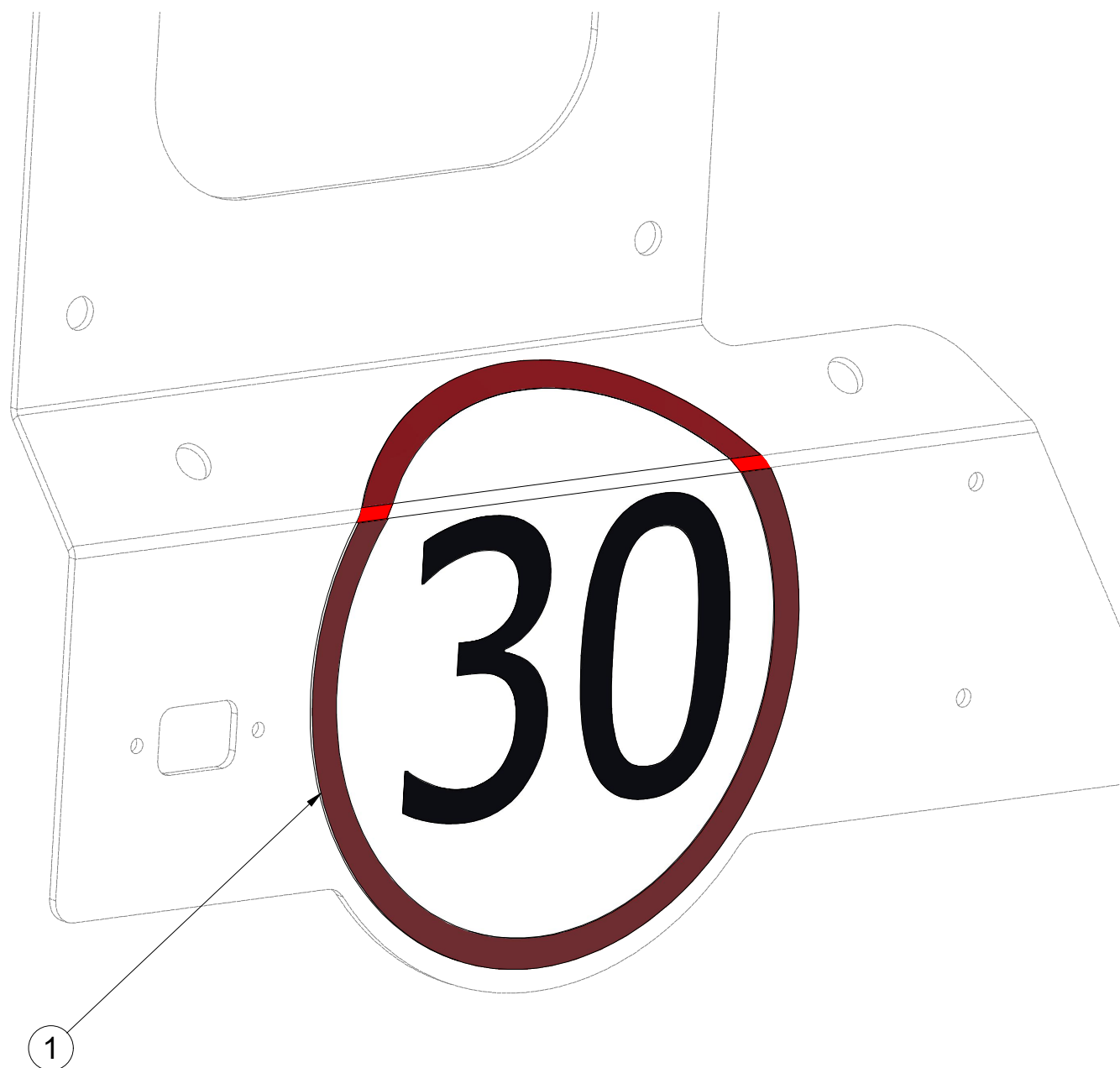

Pos.	Part Number	Pcs.
1	m19161	1

Ⓒ SVĚTELNÁ SADA

Ⓓ LEUCHTENSATZ

Ⓕ KIT LUMINEUX

**VZ00003203**

Ⓖ LIGHTING SET

Ⓡ ОСВЕТИТЕЛЬНЫЙ КОМПЛЕКТ

Ⓢ ZESTAW OŚWIETLENIA

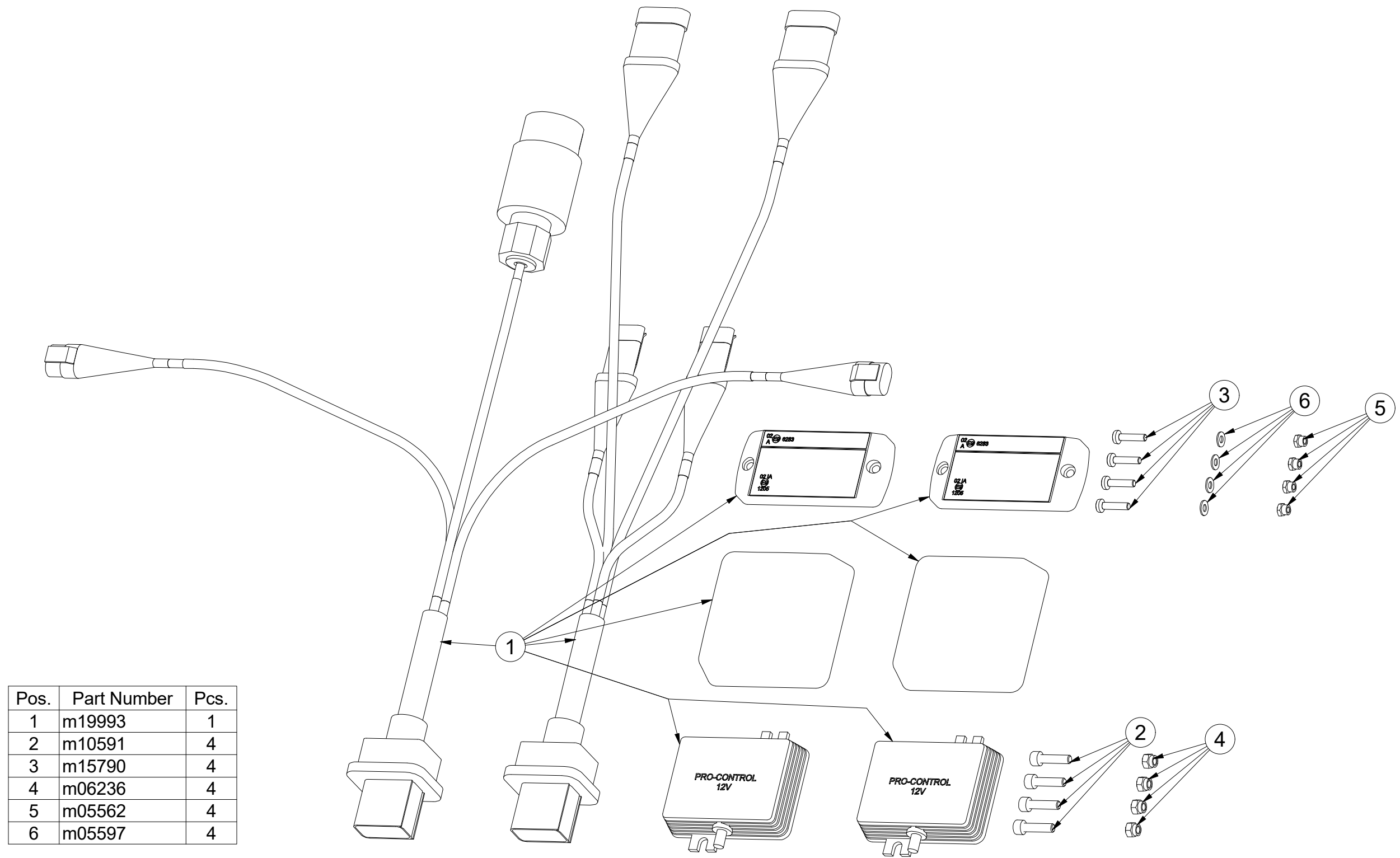

Pos.	Part Number	Pcs.
1	m19993	1
2	m10591	4
3	m15790	4
4	m06236	4
5	m05562	4
6	m05597	4

Ⓒ SVĚTELNÁ SADA

Ⓓ LEUCHTENSATZ

Ⓕ KIT LUMINEUX

**m19993**

Ⓒ LIGHTING SET

Ⓓ ОСВЕТИТЕЛЬНЫЙ КОМПЛЕКТ

Ⓕ ZESTAW OŚWIETLENIA

**Farmet**

Pos.	Part Number	Pcs.
1	m14779	1
2	m14778	1
3	m14776	2
5	m14777	2
9	m19044	2

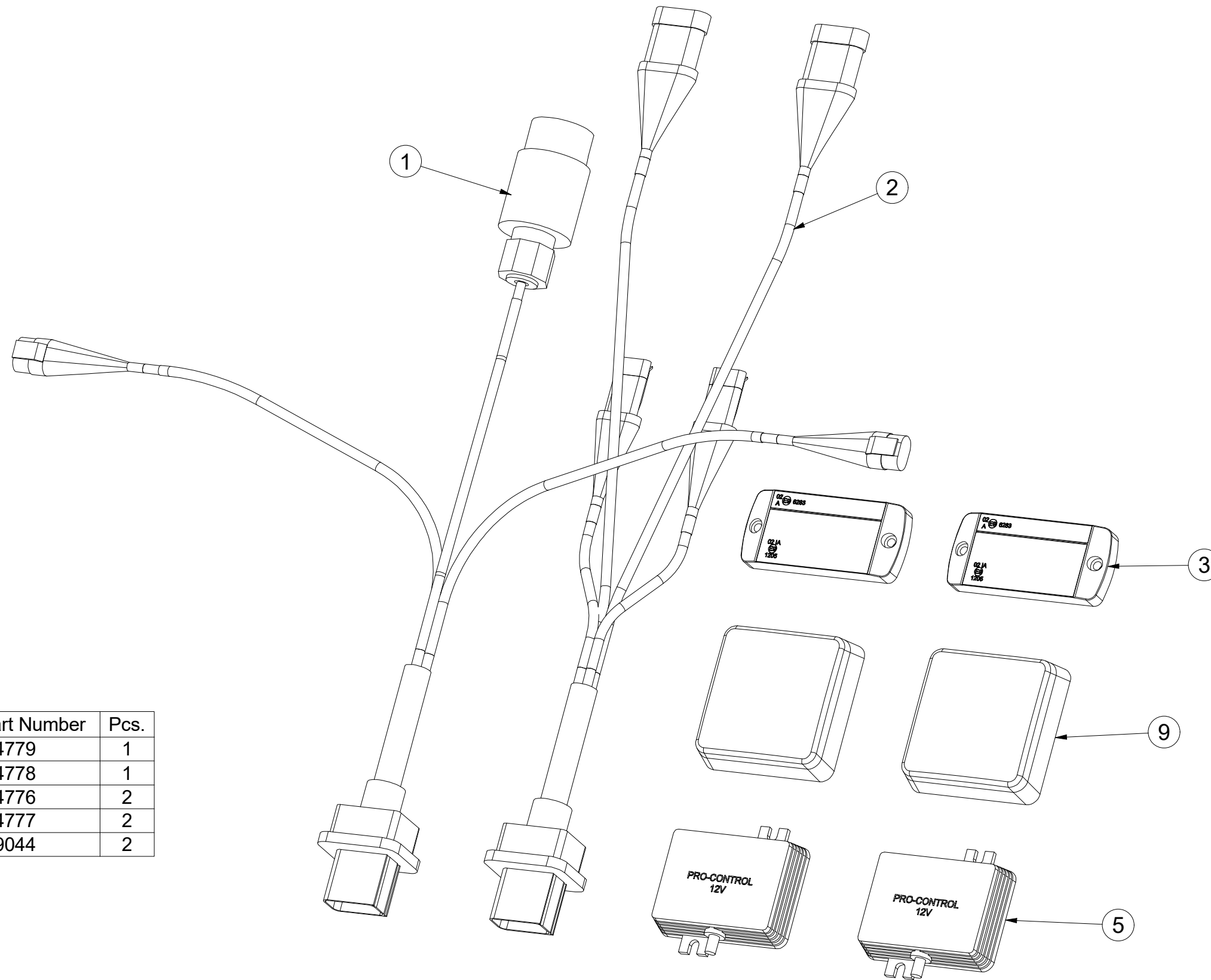



- Ⓒ UTAHOVACÍ MOMENTY ŠROUBŮ  
 Ⓓ ANZUGMOMENTE VON SCHRAUBEN  
 Ⓕ COUPLES DE SERRAGE DES VIS

- Ⓒ SCREW TIGHTENING TORQUE  
 Ⓓ МОМЕНТЫ ЗАЖАТИЯ БОЛТОВ  
 Ⓕ MOMENTY DOKRĘCANIA ŚRUB



P		5.8	8.8	10.9	12.9	Z	
D	R	Mu	Mu	Mu	Mu	DIN 7991	ISO 10642
mm	mm	Nm	Nm	Nm	Nm	Nm	Nm
M6	1	6	9	13	15	7,2	7,9
M8	1,25	14	22	32	38	17	19
M10	1,5	29	44	64	75	35	38
M12	1,75	49	76	111	130	58	65
M14	2	79	120	176	206	93	100
M16	2	123	188	276	323	144	158
M18	2,5	169	257	378	443	-	220
M20	2,5	239	365	536	628	-	310
M22	2,5	329	529	738	864	-	420
M24	3	413	629	924	1082	-	530
M27	3	613	934	1372	1606	-	-
M30	3,5	832	1267	1862	2179	-	-
M33	3,5	1130	1723	2530	2961	-	-
M36	4	1451	2210	3246	3799	-	-
M39	4	1885	2872	4217	4936	-	-
M42	4,5	2322	3538	5196	6080	-	-
M45	4,5	2909	4433	6511	7619	-	-
M48	5	3513	535	7862	9200	-	-
M52	5	4524	6895	10123	11849	-	-
M56	5,5	5636	8589	12614	14761	-	-

- Mu - Ⓒ UTAHOVACÍ MOMENT  
 Ⓓ ANZUGMOMENTE  
 Ⓕ COUPLE DE SERRAGE  
 Ⓒ TIGHTENING TORQUE  
 Ⓓ МОМЕНТ ЗАЖАТИЯ  
 Ⓕ MOMENT DOKRĘCANIA
- D - Ⓒ JMENOVITÝ PRŮMĚR  
 Ⓓ NENNDURCHMESSER  
 Ⓕ DIAMETRE NOMINAL  
 Ⓒ NOMINAL DIAMETER  
 Ⓓ НОМИНАЛЬНЫЙ ДИАМЕТР  
 Ⓕ ŚREDNICA NOMINALNA
- R - Ⓒ ROZTEČ ZÁVITU - STOUPÁNÍ  
 Ⓓ GEWINDESTEIFUNG  
 Ⓕ PAS DE FILET - PAS  
 Ⓒ SCREW PITCH – LEAD  
 Ⓓ ШАГ РЕЗЬБЫ  
 Ⓕ ROZSTAW GWINTU - SKOKI
- P - Ⓒ PEVNOST  
 Ⓓ FESTIGKEIT  
 Ⓕ RÉSISTANCE  
 Ⓒ STRENGTH  
 Ⓓ ПРОЧНОСТЬ  
 Ⓕ WYTRZYMA OŚĆ
- Z - Ⓒ ZÁPUSTNÉ ŠROUBY  
 Ⓓ SENKKOPFSCHRAUBEN  
 Ⓕ VIS A TETE FRAISEE  
 Ⓒ COUNTERSUNK SCREWS  
 Ⓓ БОЛТЫ С УТОПЛЕННОЙ ГОЛОВКОЙ  
 Ⓕ ŚRUBY Z ŁBEM STOŻKOWYM PŁASKIM

- Ⓒ Hodnoty momentů jsou poníženy o -10% oproti tabulkovým hodnotám. Šroubové spoje utahujte dle vyznačeného utahovacího momentu v dokumentaci. Pokud není utahovací moment v dokumentaci vyznačen, utahujte dle obecné tabulky. Pokud je v dokumentaci definován spoj šroubu a matice o různých pevnostech, vždy utahujte na moment komponenty nižší.
- Ⓓ Die Werte der Anzugsmomente sind um 10 % gegenüber den Tabellenwerten verringert. Ziehen Sie die Schraubverbindungen gemäß dem in der Dokumentation festgeschriebenen Anzugsmoment an. Sofern das Anzugsmoment nicht in der Dokumentation aufgeführt ist, ziehen Sie sie gemäß der allgemeinen Tabelle an. Wenn in der Dokumentation eine Verbindung von Schraube und Mutter mit verschiedene Festigkeiten definiert ist, wird immer mit dem Moment des Bauteils mit der geringeren Festigkeit angezogen.
- Ⓕ Les valeurs des couples de serrage sont baissées de 10% par rapport aux valeurs de tableau. Serrez les raccords à vis selon le couple de serrage indiqué dans les documents. Si le couple de serrage n'est pas indiqué dans les documents, serrez selon le tableau général. Si les documents définissent un assemblage par boulon de diverses résistances, serrez toujours au moment de la composante avec résistance inférieure.
- Ⓒ The torque values are reduced by 10% compared to the table values. Tighten the screw joints according to the tightening torque stated in the documentation. If the tightening torque is not stated in the documentation, tighten according to the general table. If there is a joint with a screw and a nut at different strengths in the documentation, always tighten to the torque of the component with lower strength.
- Ⓓ Значения моментов затяжки уменьшены на 10% по сравнению с данными в таблице. Резьбовые соединения зажимайте с установленным в документации моментом зажатия. Если в документации не указан момент зажатия, то зажимайте по действующей в общем таблице. Если в документации установлено соединение из болта и гайки различной прочности, всегда зажимайте с моментом для компонента с меньшей прочностью.
- Ⓕ Wartości momentów dokręcania są obniżone o 10% w stosunku do wartości z tabeli. Połączenia śrubowe należy dokręcać zgodnie z momentem obrotowym w dokumentacji. Jeśli w dokumentacji nie ma podanego momentu obrotowego, należy dokręcać zgodnie z ogólną tabelą. Jeśli w dokumentacji zdefiniowane jest połączenie ze śrubą nakrętką różnych wytrzymałościach, zawsze należy dokręcać zachowując moment dokręcania komponentu z niższą wytrzymałością.

- Ⓒ UTAHOVACÍ MOMENTY ŠROUBŮ  
 Ⓓ ANZUGMOMENTE VON SCHRAUBEN  
 Ⓕ COUPLES DE SERRAGE DES VIS

- Ⓖ SCREW TIGHTENING TORQUE  
 Ⓡ МОМЕНТЫ ЗАЖАТИЯ БОЛТОВ  
 Ⓟ MOMENTY DOKRĘCANIA ŚRUB



- Ⓒ **OBECNÝ PŘEDPIS UTAHOVÁNÍ ZAJIŠTĚNÍ ČEPOVÝCH SPOJŮ:**  
 Ⓓ **ALLGEMEINE VORSCHRIFT FÜR DAS ANZIEHEN VON BOLZENVERBINDUNGEN:**  
 Ⓕ **CONSIGNE GENERALE POUR LE SERRAGE DES ARTICULATIONS CYLINDRIQUES:**  
 Ⓖ **GENERAL INSTRUCTION FOR TIGHTENING THE SECURING OF PIN JOINTS:**  
 Ⓡ **ОБЩЕЕ ОПИСАНИЕ ЗАЖАТИЯ ПРЕДОХРАНЕНИЯ СОЕДИНЕНИЙ ПАЛЬЦАМИ:**  
 Ⓟ **OGÓLNE ZASADY DOKRĘCANIA ZABEZPIECZENIA POŁĄCZEŃ CZOPEM:**



**X**

M8, M10, M12

M14

**M**

09-15Nm

15-25Nm

- X - Ⓒ ROZMĚR ŠROUBU  
 Ⓓ SCHRAUBENGRÖSSE  
 Ⓕ DIMENSIONS DE LA VIS

- Ⓖ BOLT DIMENSION  
 Ⓡ РАЗМЕР БОЛТА  
 Ⓟ ROZMIAR ŚRUBY

- M - Ⓒ ORIENTAČNÍ MOMENT  
 Ⓓ ANZUGSMOMENT  
 Ⓕ COUPLE D'ORIENTATION

- Ⓖ ORIENTATION TORQUE  
 Ⓡ ОРИЕНТАЦИОННЫЙ МОМЕНТ  
 Ⓟ ORIENTACYJNY MOMENT

- Ⓒ Tyto spoje není nutné ověřovat kontrolou momentovým klíčem = stačí vizuálně kontrolovat sešroubování.  
 Ⓓ Diese Verbindungen müssen nicht mit einem Drehmomentschlüssel überprüft werden = es genügt, die Verschraubung visuell zu kontrollieren.  
 Ⓕ Il n'est pas nécessaire de contrôler le serrage à l'aide d'une clé dynamométrique = un contrôle visuel de l'assemblage suffit.  
 Ⓖ These joints do not have to be verified by checking with a torque wrench = visual inspection of bolting is sufficient.  
 Ⓡ Эти соединения не нужно контролировать динамометрическим ключом = достаточно визуально проверять прикручивание.  
 Ⓟ Nie trzeba sprawdzać tych połączeń kluczem dynamometrycznym = wystarczy wizualnie skontrolować dokręcenie.