

The effective technology

Farmet®

ⒸZ KATALOG NÁHRADNÍCH DÍLŮ ⒸB CATALOGUE OF SPARE PARTS ⒸD ERSATZTEILLISTE
ⒸRU КАТАЛОГ ЗАПАСНЫХ ЧАСТЕЙ ⒸF CATALOGUE DES PIÈCES DE RECHANGE ⒸPL KATALOG CZĘŚCI ZAMIENNYCH

КОМПАКТОМАТ K400PS

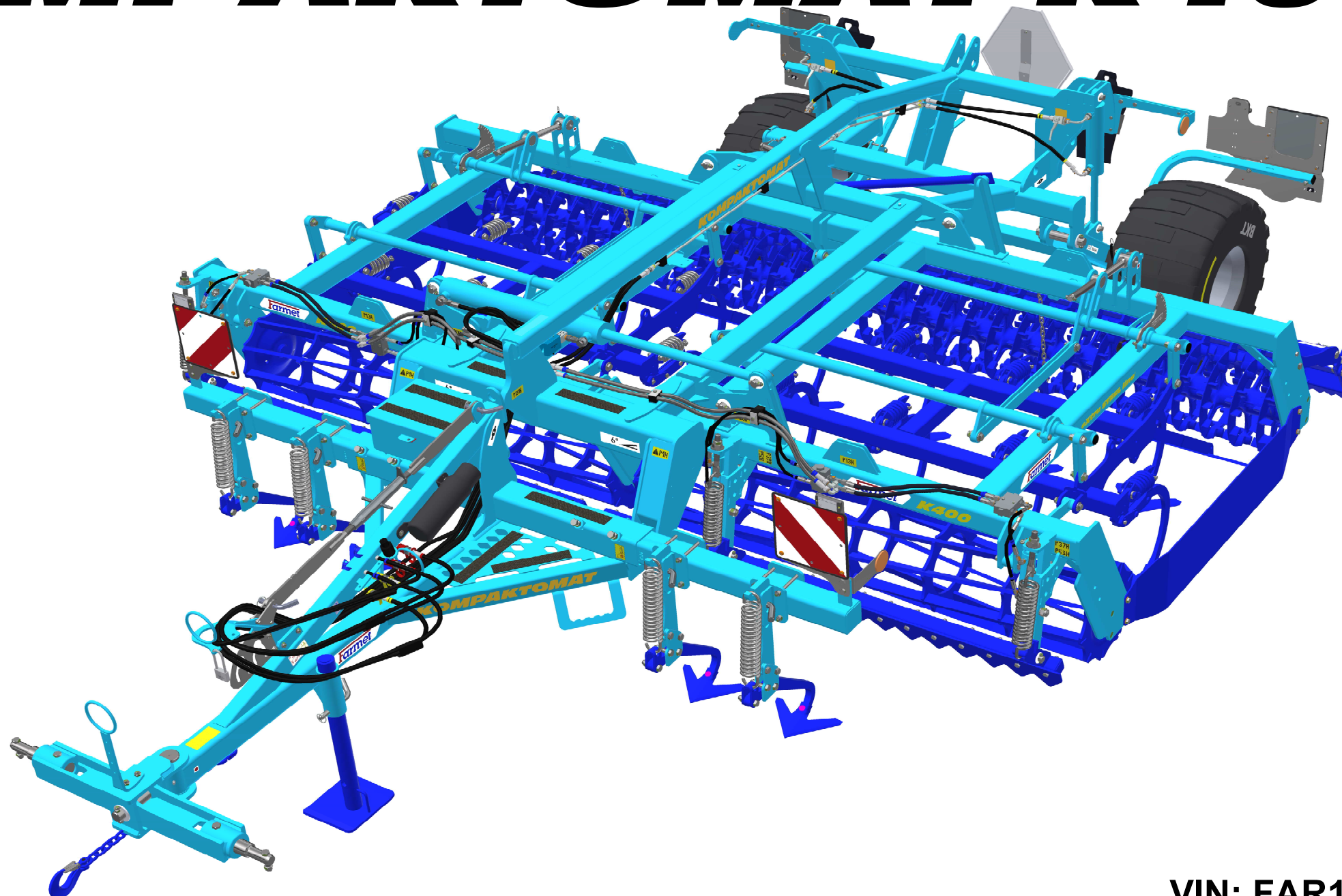

ⒸZ Platnost pro vrcholové | výrobní číslo stroje ⒸB Validity for the top | serial number of the machine
ⒸD Gültigkeit für die Haupt- | Herstellungsnummer der Maschine ⒸRU Действительно для главного | заводского номера машины
ⒸF Validité du numéro de référence | de série de la machine ⒸPL Obowiązuje dla numeru głównego | seryjnego maszyny

VIN: FAR12025LN0000865
9333603 | 2022/0865

Farmet a. s.
Jiřinková 276
552 03 Česká Skalice, CZ

telefon: +420 491 450 111
fax: +420 491 450 136
GSM: +420 774 715 738

IČ: 46504931
DIČ: CZ46504931

web: www.farmet.cz
e-mail: farmet@farmet.cz

ⒸZ NAVIGACE STROJE

Ⓓ NAVIGATION DER MASCHINE

Ⓕ NAVIGATION DE LA MACHINE

ⒸB NAVIGATION OF THE MACHINE

ⒸU НАВИГАЦИЯ МАШИНЫ

ⒸL NAWIGACJA MASZYNY

Farmet

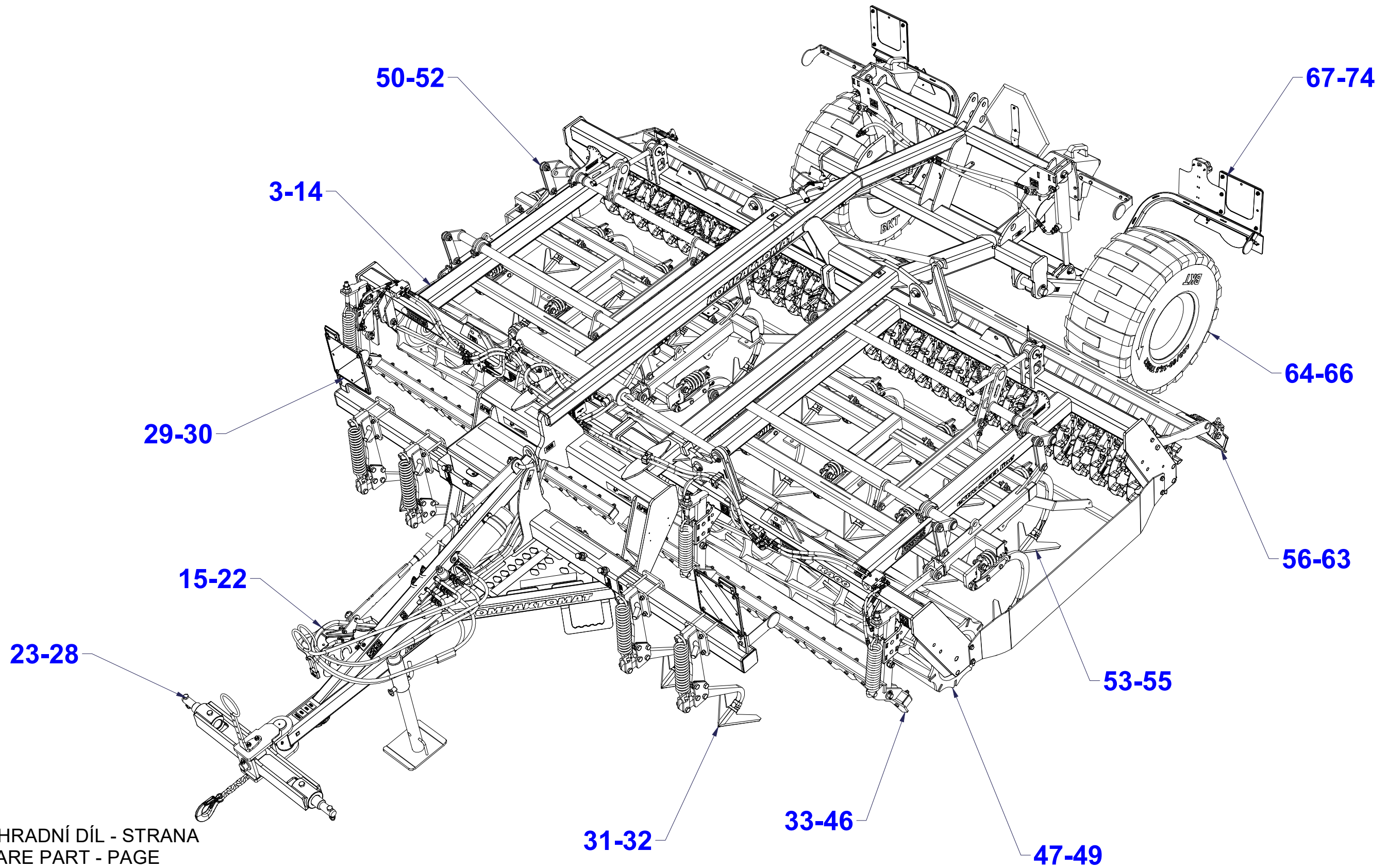

ⒸZ NÁHRADNÍ DÍL - STRANA

ⒸB SPARE PART - PAGE

Ⓓ ERSATZTEILE - SEITE

ⒸU ЗАПЧАСТЬ - СТРАНИЦА

Ⓕ PIÈCE DE RECHANGE - PAGE

ⒸL CZĘŚCI ZAMIENNE - STRONA

☉ POLOTOVAR STROJE

Ⓧ MASCHINEN-HALBFABRIKAT

Ⓣ MACHINE - SEMI-PRODUIT

Ⓢ SEMIFINISHED MACHINE

Ⓡ ПОЛУФАБРИКАТ МАШИНЫ

Ⓛ PÓŁFABRYKAT MASZYN



VZ00019445

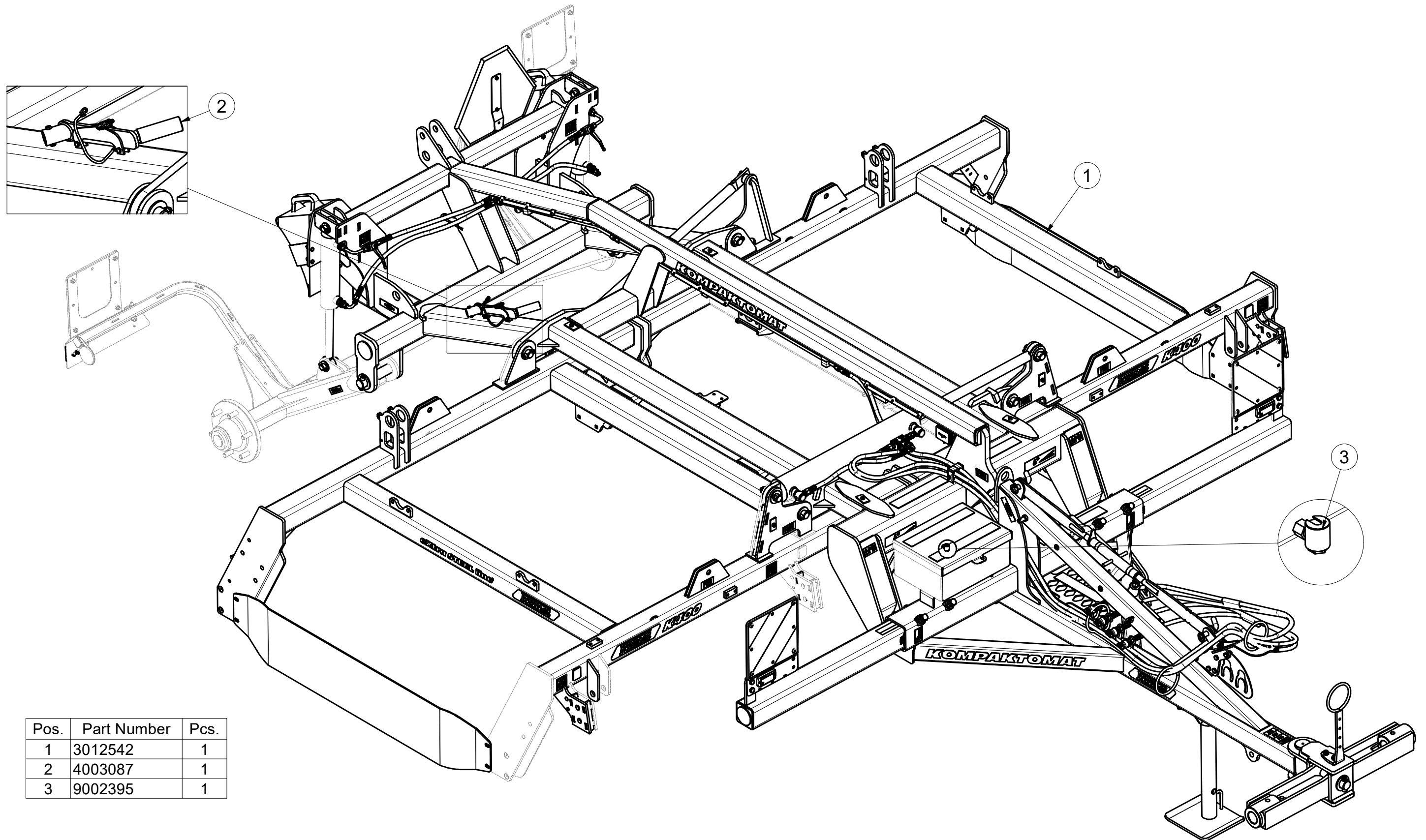

Pos.	Part Number	Pcs.
1	3012542	1
2	4003087	1
3	9002395	1

Ⓒ NASAZOVACÍ KLIKA

Ⓓ MONTAGEGRIF

Ⓕ POIGNÉE DE MONTAGE

4003087

Ⓖ MOUNTING HANDLE

Ⓡ МОНТАЖНАЯ РУЧКА

Ⓢ UCHWYT MONTAŻOWY

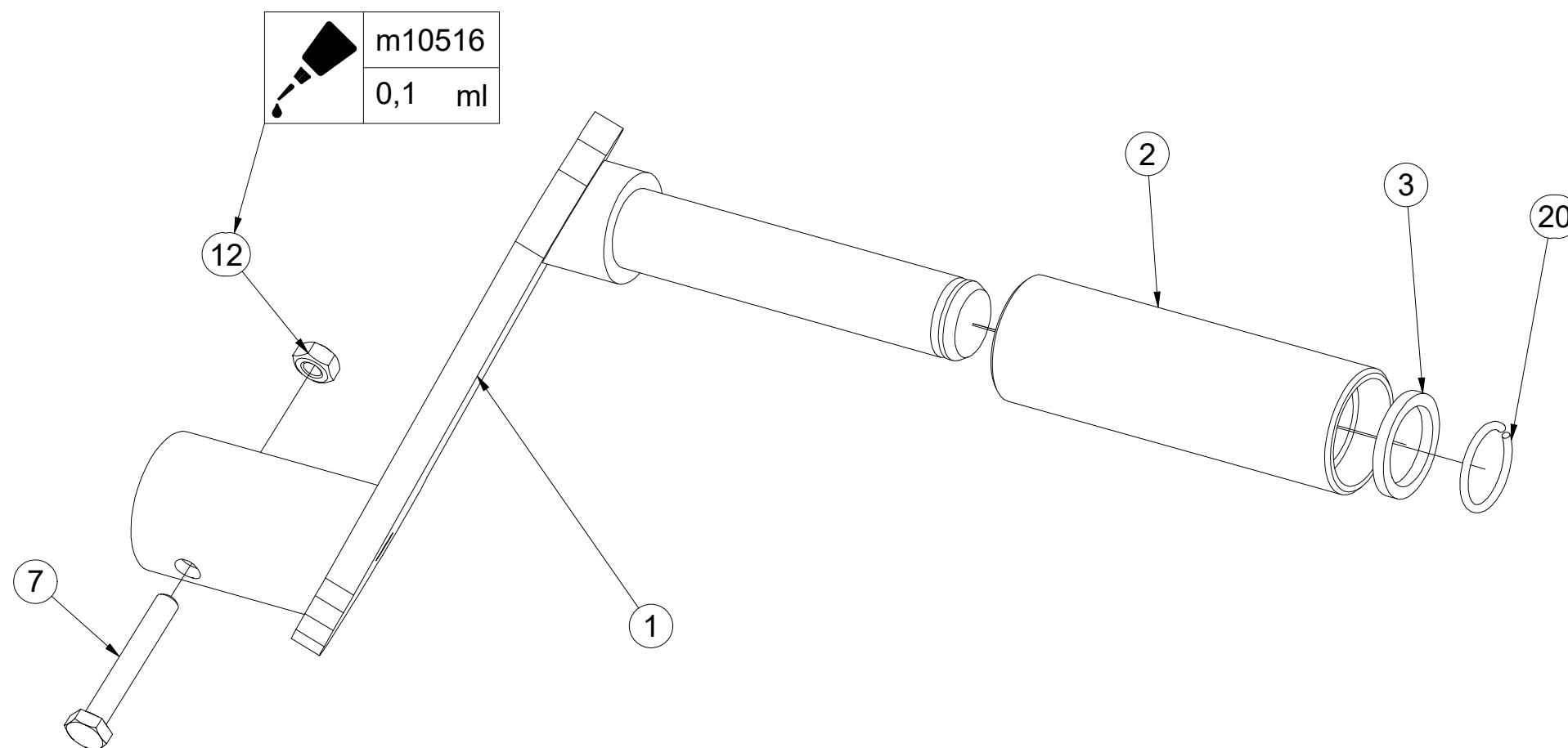
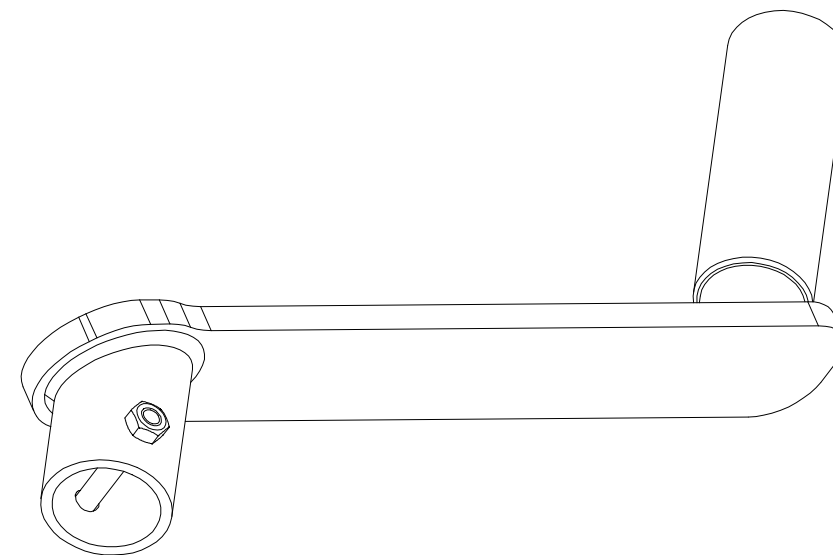

Pos.	Part Number	Pcs.
1	4003092	1
2	4001533	1
3	4004828	1
7	m04641	1
12	m01295	1
20	m06561	1
25	m10516	0,1

Ⓒ POLOTOVAR STROJE

Ⓓ MASCHINEN-HALBFABRIKAT

Ⓕ MACHINE - SEMI-PRODUIT

Ⓖ SEMIFINISHED MACHINE

Ⓡ ПОЛУФАБРИКАТ МАШИНЫ

Ⓢ РÓЉФАБРЫКАТ МАСЗЫНЫ



VZ00023674

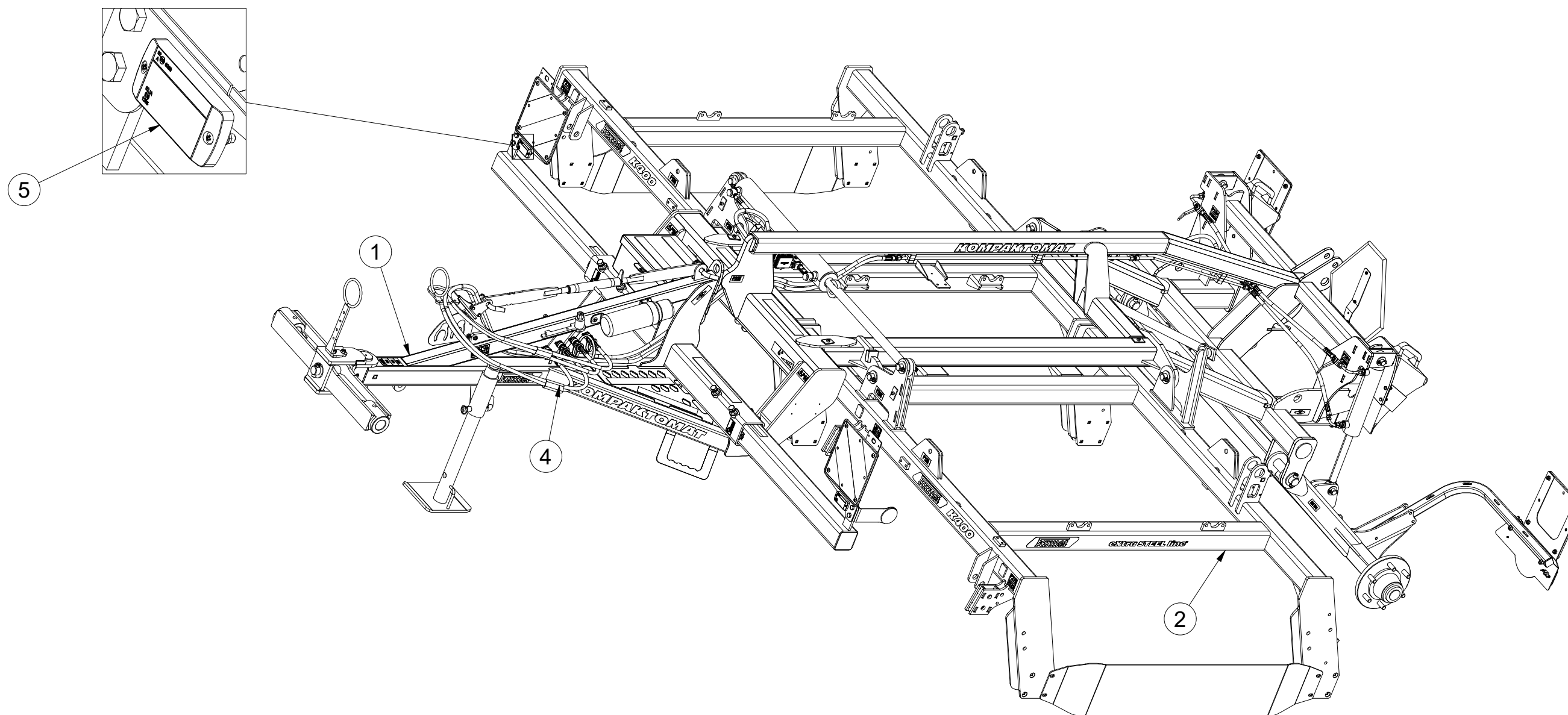

Pos.	Part Number	Pcs.
1	VZ00023550	1
2	VZ00023756	1
4	3012561	1
5	3012562	1

Ⓒ POLOTOVAR STROJE

Ⓓ MASCHINEN-HALBFABRIKAT

Ⓕ MACHINE - SEMI-PRODUIT

Ⓖ SEMIFINISHED MACHINE

Ⓡ ПОЛУФАБРИКАТ МАШИНЫ

Ⓢ РОЉФАБРИКАТ МАСЗЫНЫ



VZ00023674

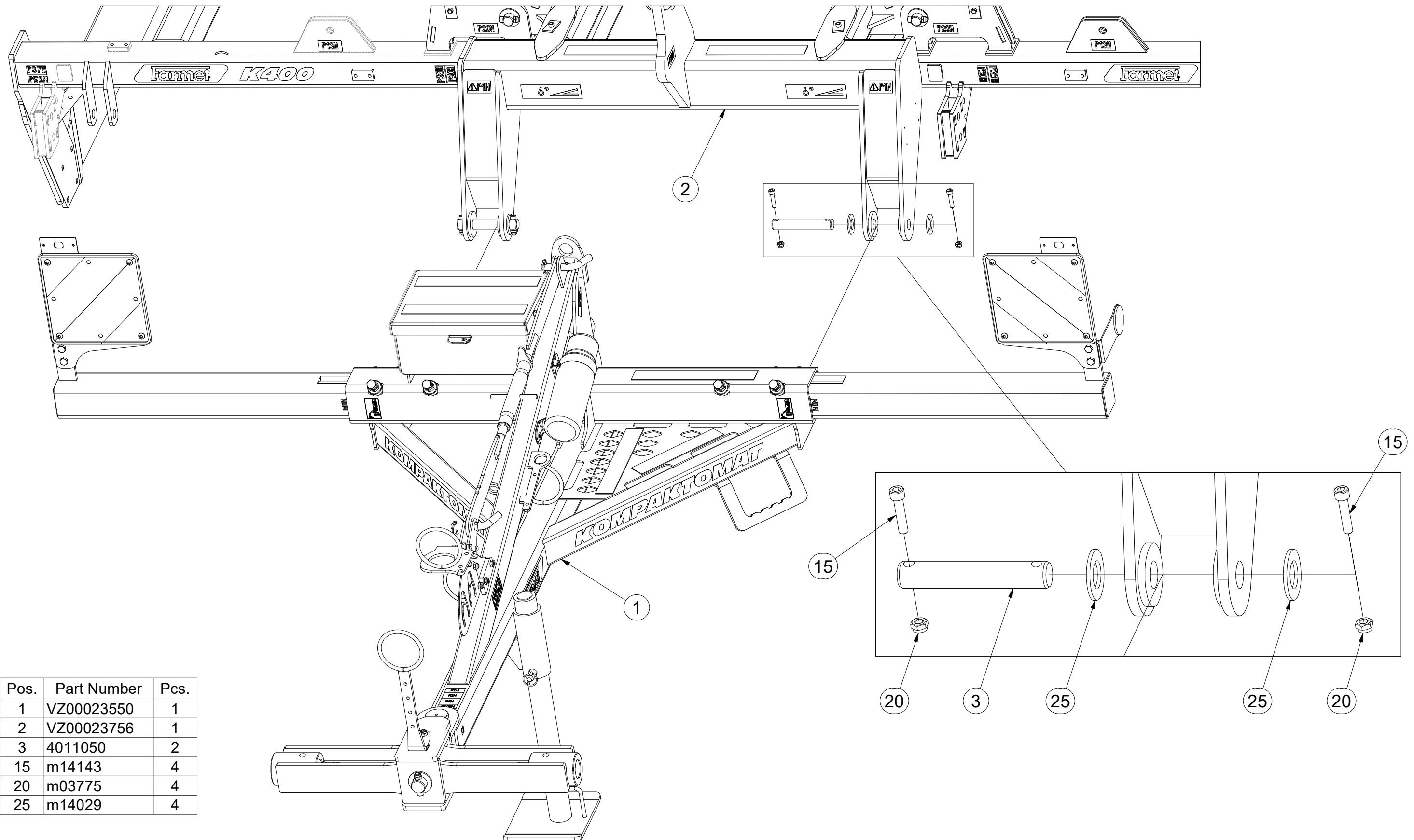

Pos.	Part Number	Pcs.
1	VZ00023550	1
2	VZ00023756	1
3	4011050	2
15	m14143	4
20	m03775	4
25	m14029	4

Ⓒ POLOTOVAR STROJE

Ⓓ MASCHINEN-HALBFABRIKAT

Ⓕ MACHINE - SEMI-PRODUIT

Ⓖ SEMIFINISHED MACHINE

Ⓡ ПОЛУФАБРИКАТ МАШИНЫ

Ⓟ PÓŁFABRYKAT MASZYN



VZ00023756

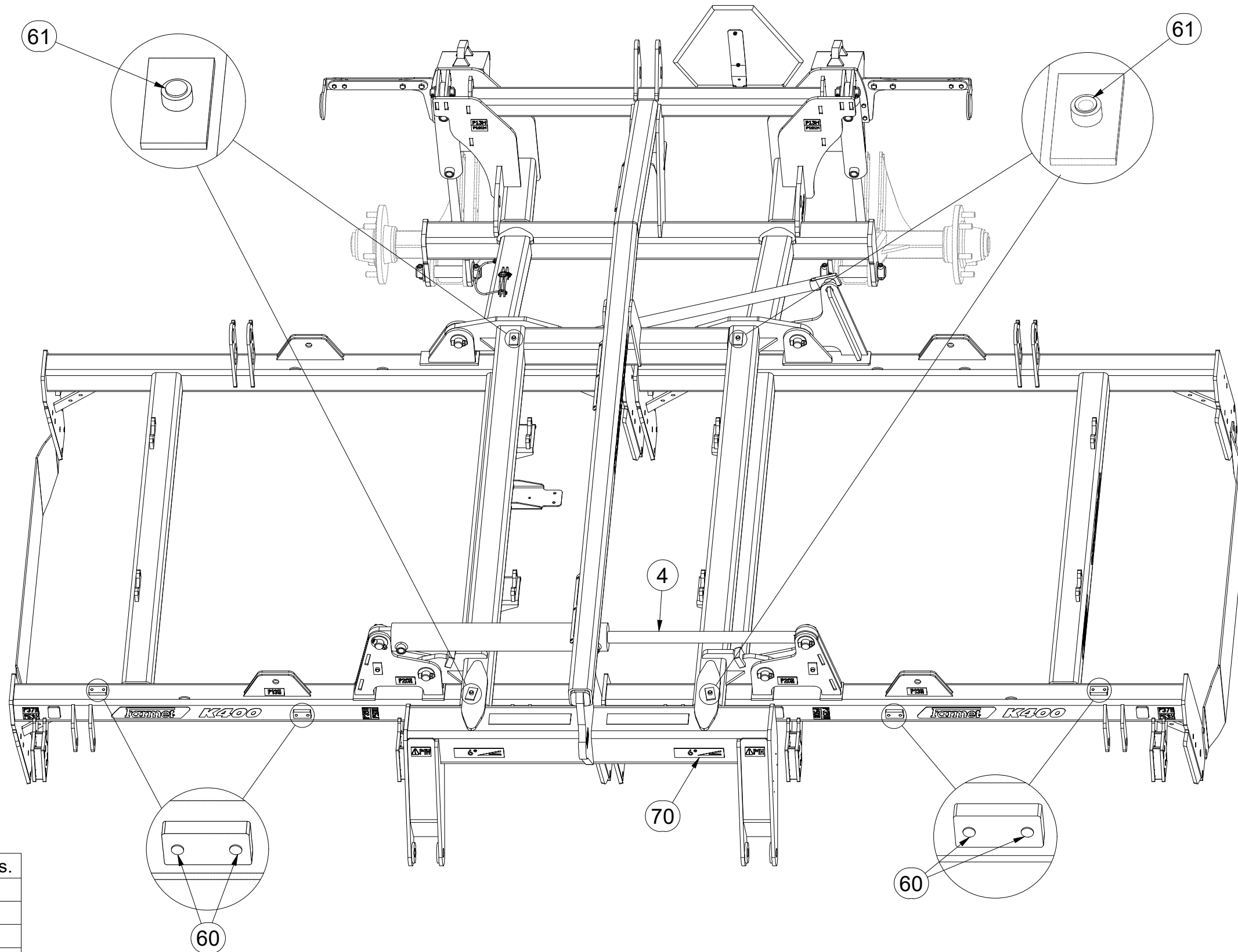

Pos.	Part Number	Pcs.
4	VZ00004545	1
60	m11099	8
61	m12142	6
70	m22749	1

Ⓒ POLOTOVAR STROJE

Ⓓ MASCHINEN-HALBFABRIKAT

Ⓕ MACHINE - SEMI-PRODUIT

Ⓖ SEMIFINISHED MACHINE

Ⓡ ПОЛУФАБРИКАТ МАШИНЫ

Ⓢ PÓŁFABRYKAT MASZYN



VZ00023756

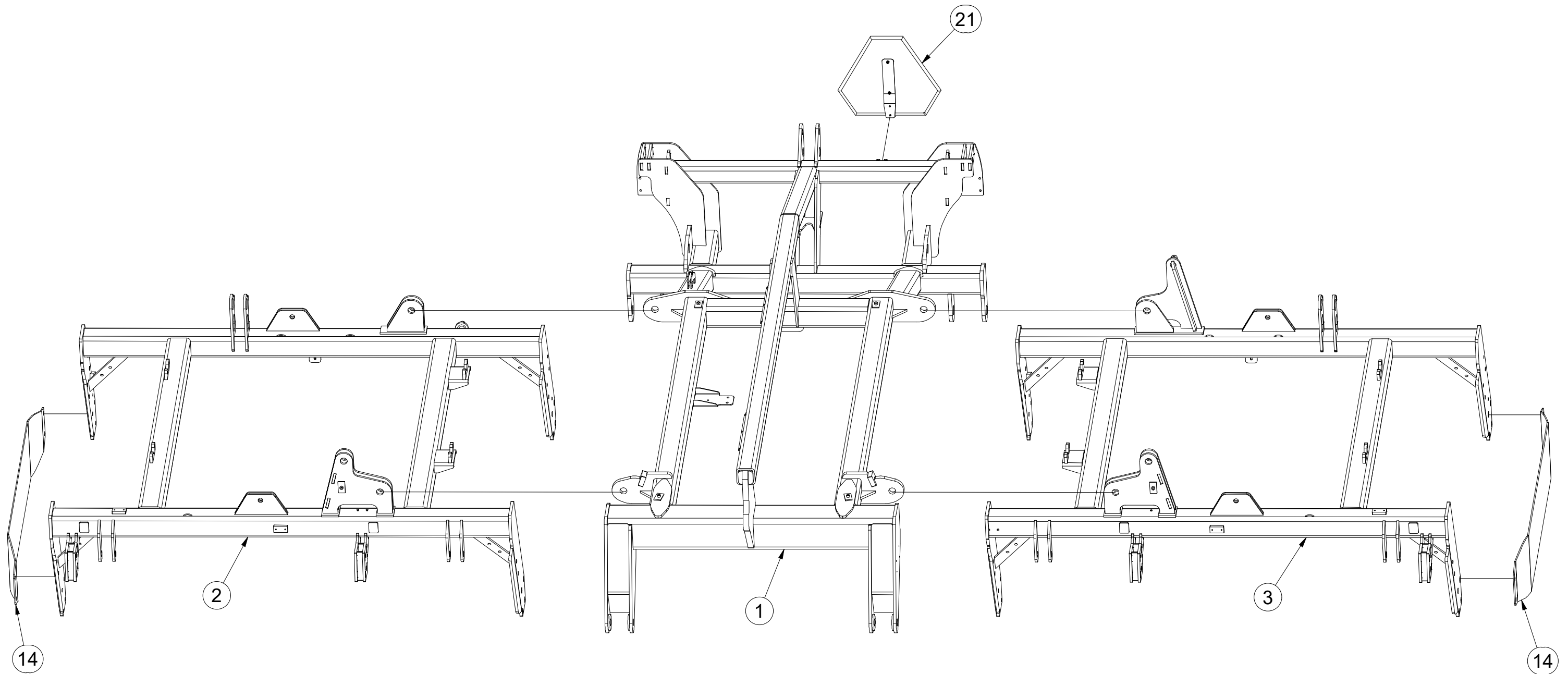

Pos.	Part Number	Pcs.
1	2001262	1
2	6000446	1
3	6000445	1
14	4016427	2
21	m05371	1

☉ POLOTOVAR STROJE

☉ MASCHINEN-HALBFABRIKAT

☉ MACHINE - SEMI-PRODUIT

☉ SEMIFINISHED MACHINE

☉ ПОЛУФАБРИКАТ МАШИНЫ

☉ PÓLFABRYKAT MASZYNY



VZ00023756

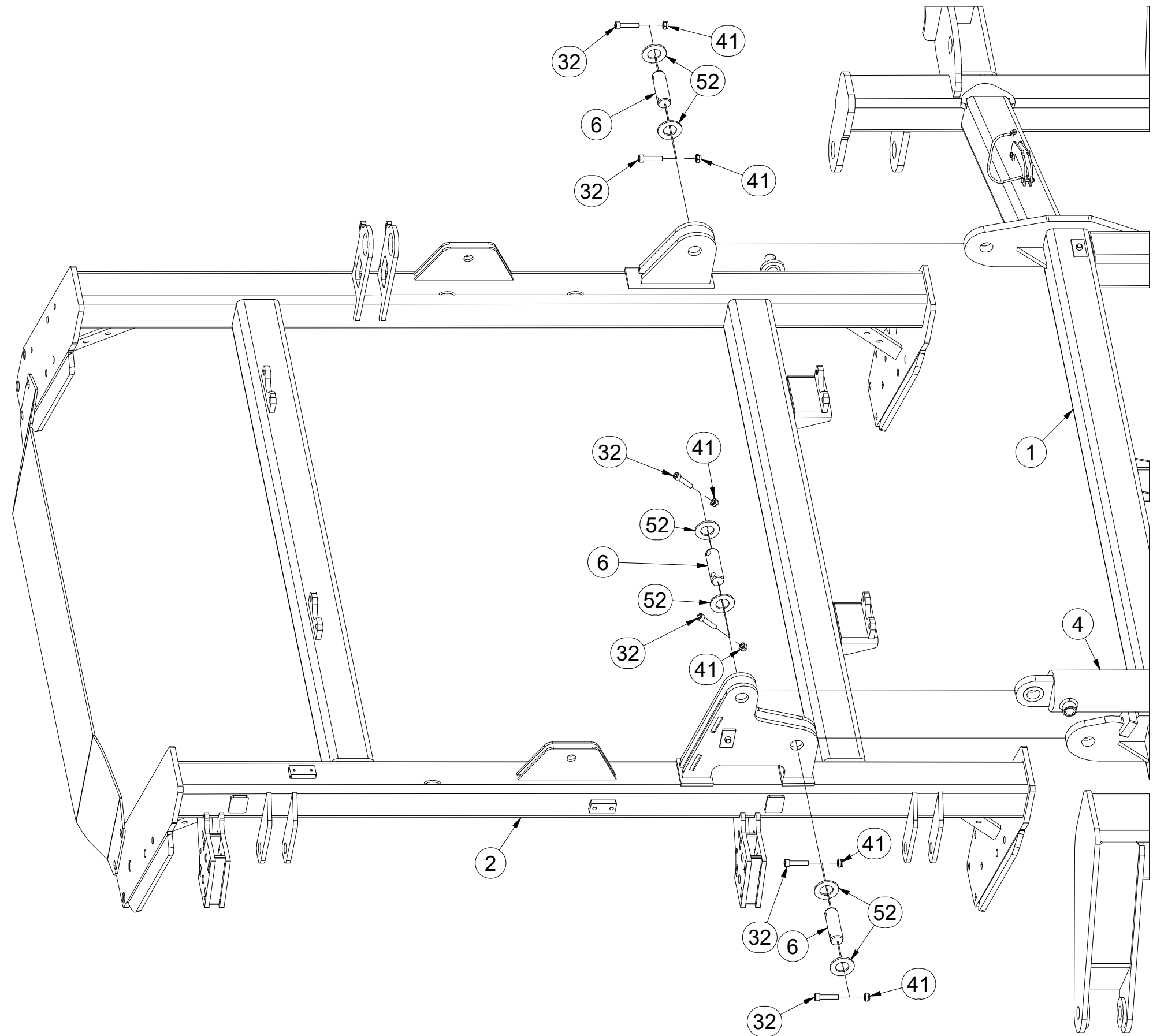

Pos.	Part Number	Pcs.
1	2001262	1
2	6000446	1
4	VZ00004545	1
6	4007640	6
32	m14143	12
41	m03775	16
52	m14029	12

Ⓒ POLOTOVAR STROJE

Ⓓ MASCHINEN-HALBFABRIKAT

Ⓕ MACHINE - SEMI-PRODUIT

Ⓒ SEMIFINISHED MACHINE

Ⓓ ПОЛУФАБРИКАТ МАШИНЫ

Ⓕ PÓŁFABRYKAT MASZYN



VZ00023756

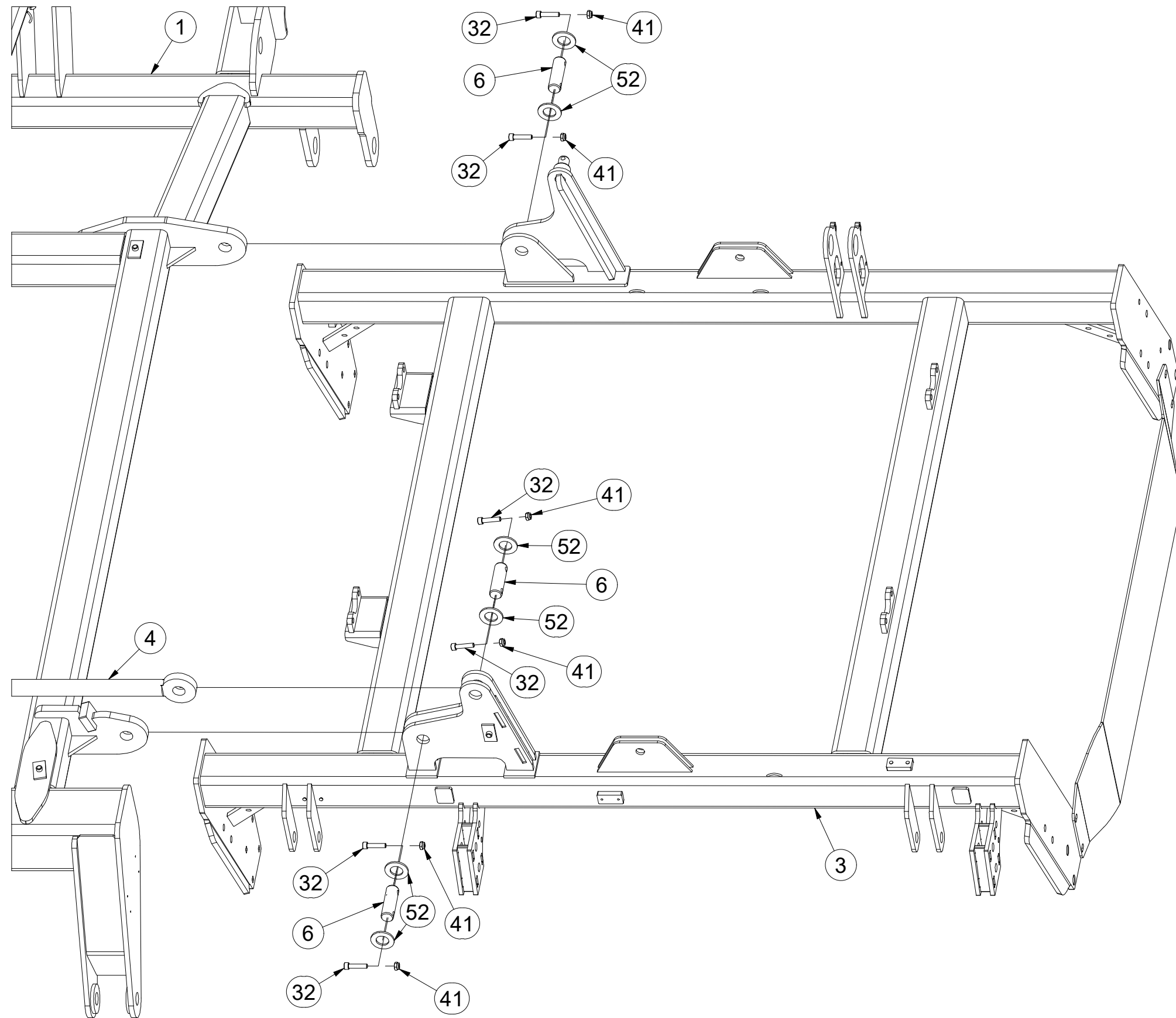

Pos.	Part Number	Pcs.
1	2001262	1
3	6000445	1
4	VZ00004545	1
6	4007640	6
32	m14143	12
41	m03775	16
52	m14029	12

☉ POLOTOVAR STROJE

☉ MASCHINEN-HALBFABRIKAT

☉ MACHINE - SEMI-PRODUIT

☉ SEMIFINISHED MACHINE

☉ ПОЛУФАБРИКАТ МАШИНЫ

☉ PÓLFABRYKAT MASZYNY



VZ00023756

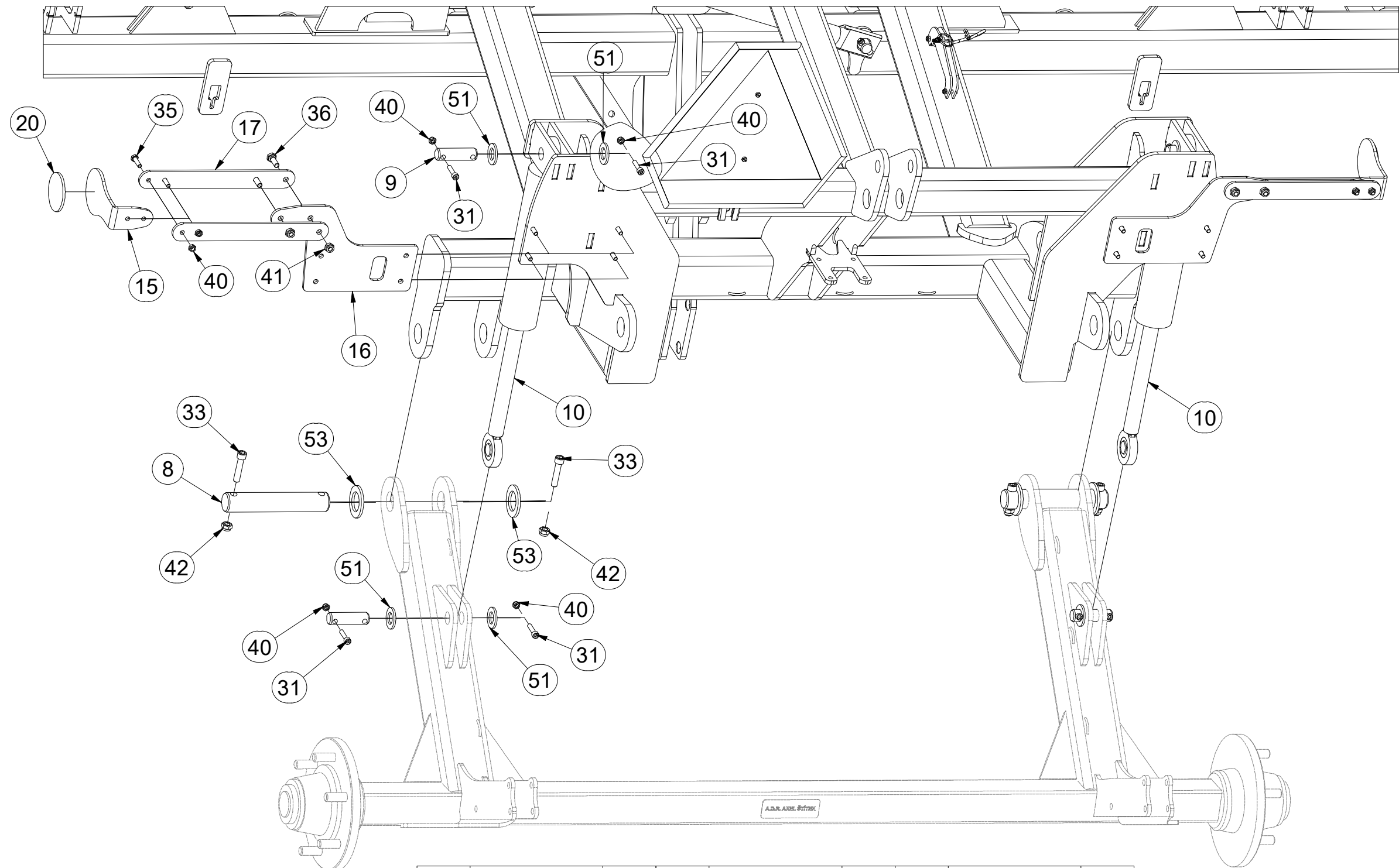

Pos.	Part Number	Pcs.	Pos.	Part Number	Pcs.	Pos.	Part Number	Pcs.
8	4010875	2	17	VZ00023544	4	36	m04612	4
9	4010390	4	20	m02579	2	40	m04503	22
10	VZ00015266	2	31	m09464	10	41	m03775	16
15	VZ00023545	2	33	m14008	4	42	m04301	4
16	VZ00023543	2	35	m07788	4	51	m14028	8
						53	4013139	4

Ⓒ POLOTOVAR STROJE

Ⓓ MASCHINEN-HALBFABRIKAT

Ⓕ MACHINE - SEMI-PRODUIT

Ⓖ SEMIFINISHED MACHINE

Ⓡ ПОЛУФАБРИКАТ МАШИНЫ

Ⓢ PÓLFABRYKAT MASZYNY



VZ00023756

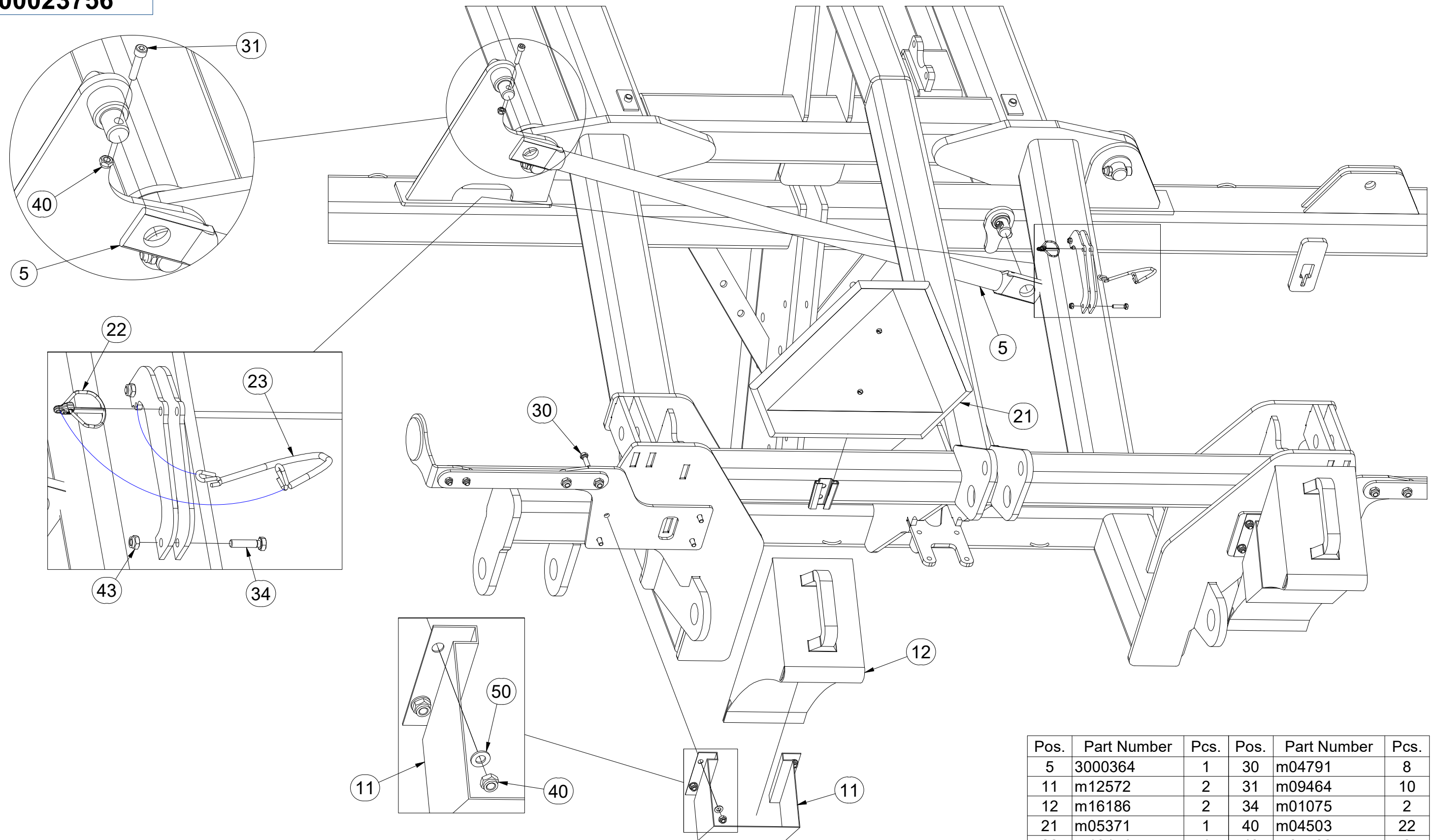

Pos.	Part Number	Pcs.	Pos.	Part Number	Pcs.
5	300364	1	30	m04791	8
11	m12572	2	31	m09464	10
12	m16186	2	34	m01075	2
21	m05371	1	40	m04503	22
22	m10454	1	43	m05560	2
23	m12467	1	50	m01203	8

☉ SAMOLEPKY STROJE

☉ AUFKLEBER MASCHINEN

☉ VOITURE MACHINES

☉ STICKERS MACHINES

☉ СТИКЕРЫ МАШИНЫ

☉ NAKLEJKI MASZYNY



m22749

Pos.	Part Number	Pcs.	Pos.	Part Number	Pcs.
1	m11147	2	8	m04359	3
2	m07688	2	9	m03316	2
3	m10353	2	10	m03314	2
4	m13116	6	12	m11299	2
5	m11297	4	13	m04363	2
6	m07690	4	14	m04368	5
7	m11296	4	15	m03320	2

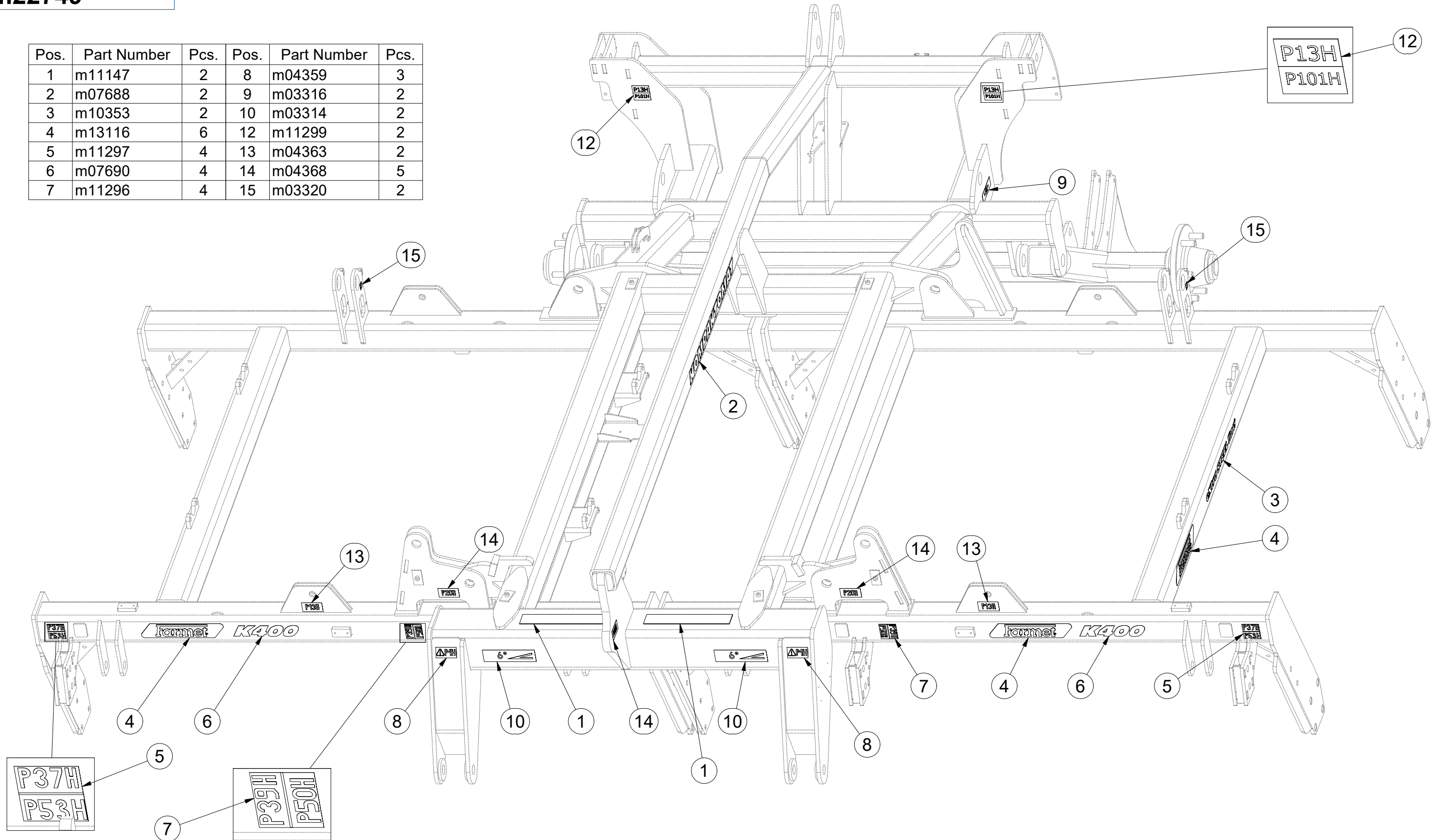

m22749

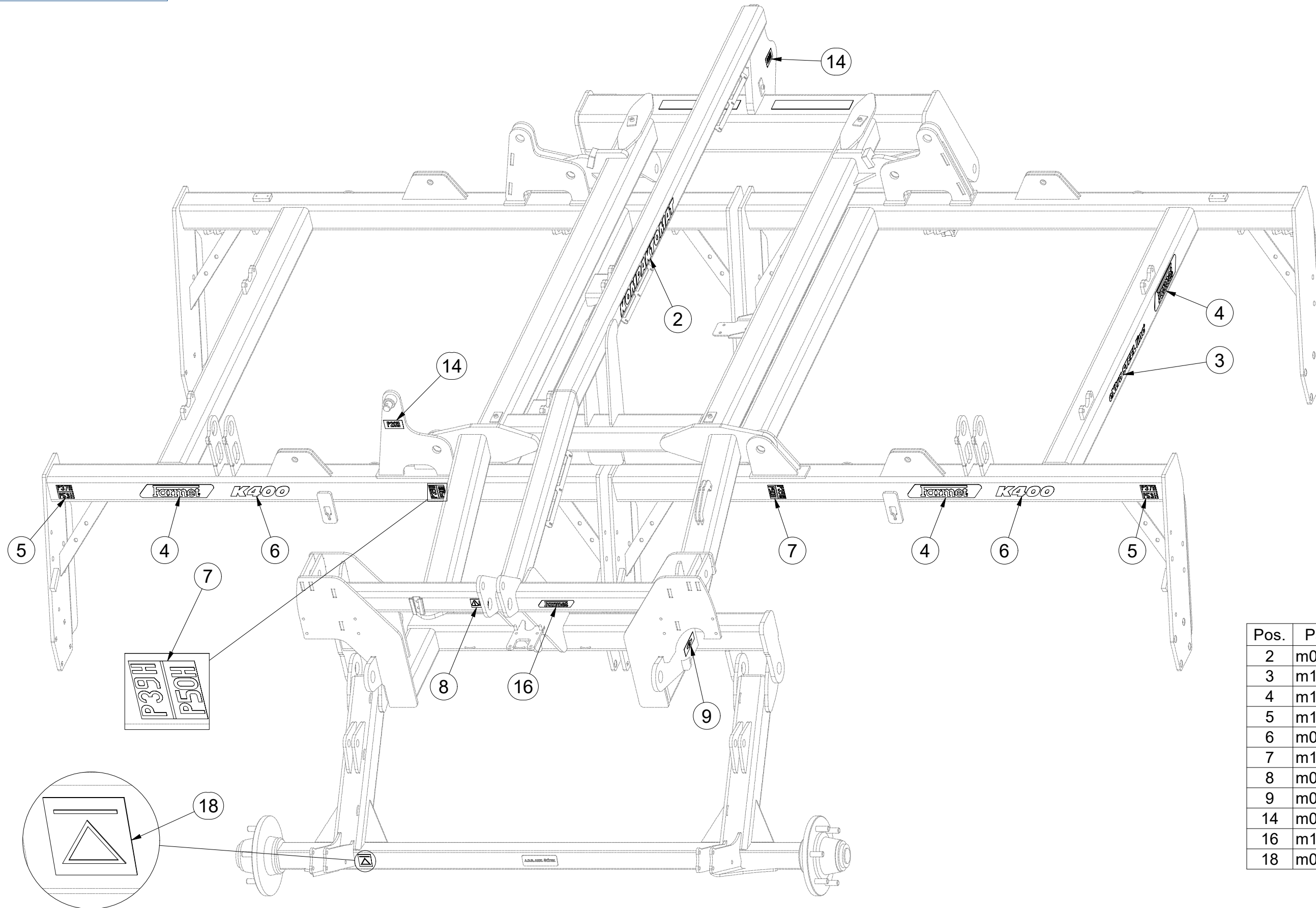

Pos.	Part Number	Pcs.
2	m07688	2
3	m10353	2
4	m13116	6
5	m11297	4
6	m07690	4
7	m11296	4
8	m04359	3
9	m03316	2
14	m04368	5
16	m13401	1
18	m03512	2

ⒸZ HYDRAULIKA STROJE

Ⓓ HYDRAULIK DER MASCHINE

Ⓕ HYDRAULIQUE DE LA MACHINE

3012561

ⒸGB MACHINE HYDRAULICS

ⒸRU ГИДРАВЛИКА МАШИНЫ

ⒸPL HYDRAULIKA MASZYNY

Farmet

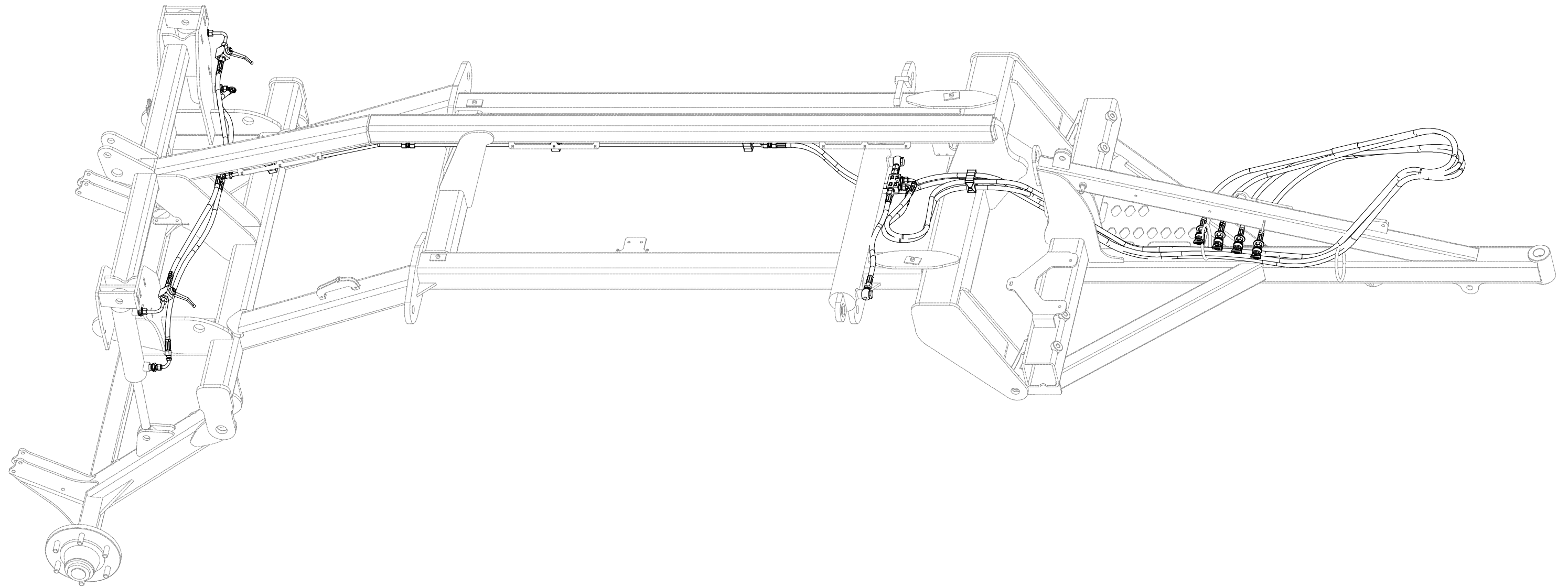

Ⓒ HYDRAULIKA STROJE

Ⓓ HYDRAULIK DER MASCHINE

Ⓕ HYDRAULIQUE DE LA MACHINE

Ⓖ MACHINE HYDRAULICS

Ⓡ ГИДРАВЛИКА МАШИНЫ

Ⓟ HYDRAULIKA MASZYN



3012561

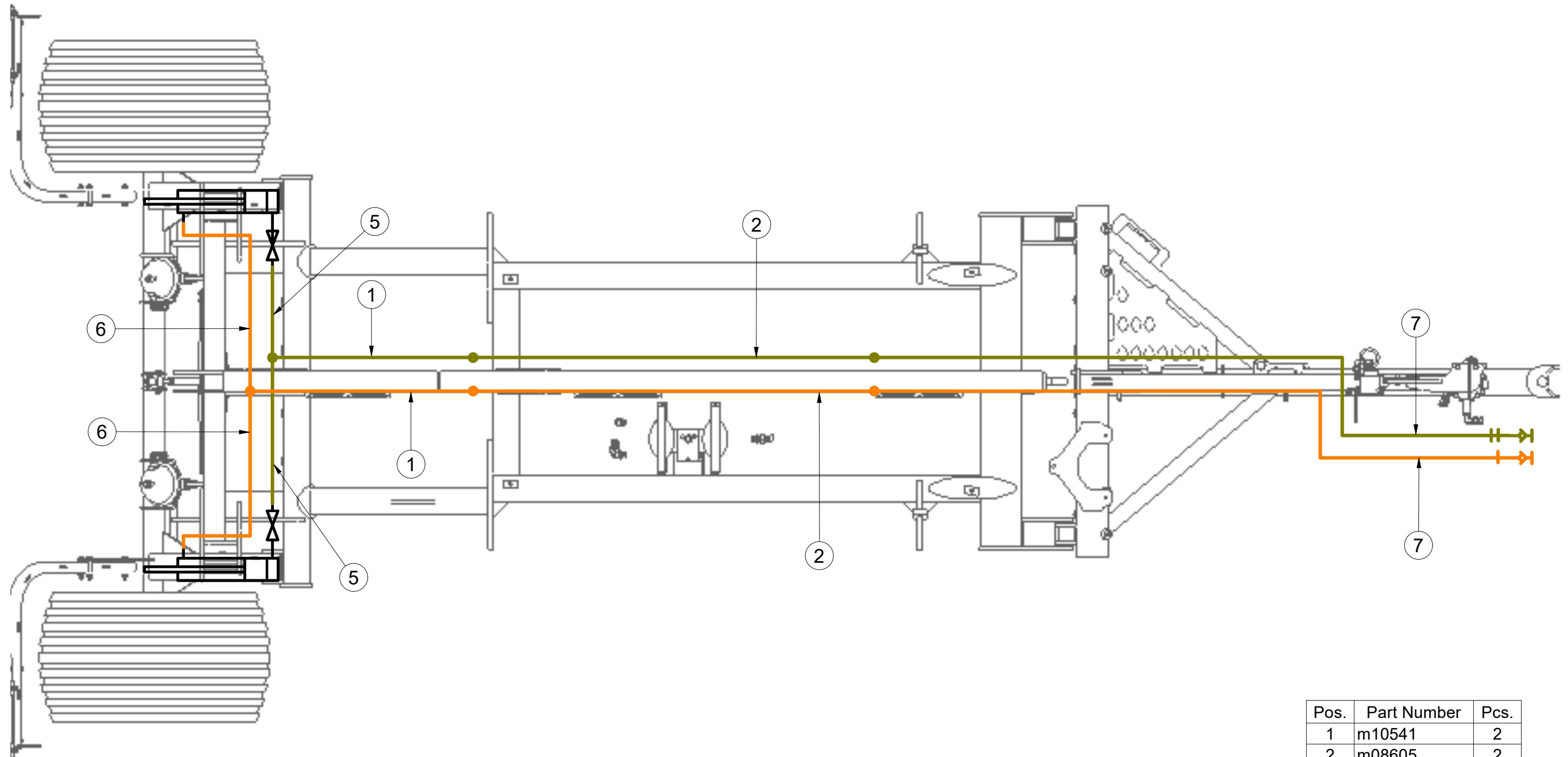

Pos.	Part Number	Pcs.
1	m10541	2
2	m08605	2
5	m04761	2
6	m07909	2
7	m04087	4

ⒸZ HYDRAULIKA STROJE

Ⓓ HYDRAULIK DER MASCHINE

Ⓕ HYDRAULIQUE DE LA MACHINE

ⒸB MACHINE HYDRAULICS

ⒸR ГИДРАВЛИКА МАШИНЫ

ⒸL HYDRAULIKA MASZYN



3012561

Pos.	Part Number	Pcs.	Pos.	Part Number	Pcs.
1	m10541	2	27	m04009	6
2	m08605	2	40	m04021	6
7	m04087	4	42	m04346	6
12	m03213	4	50	m11289	15

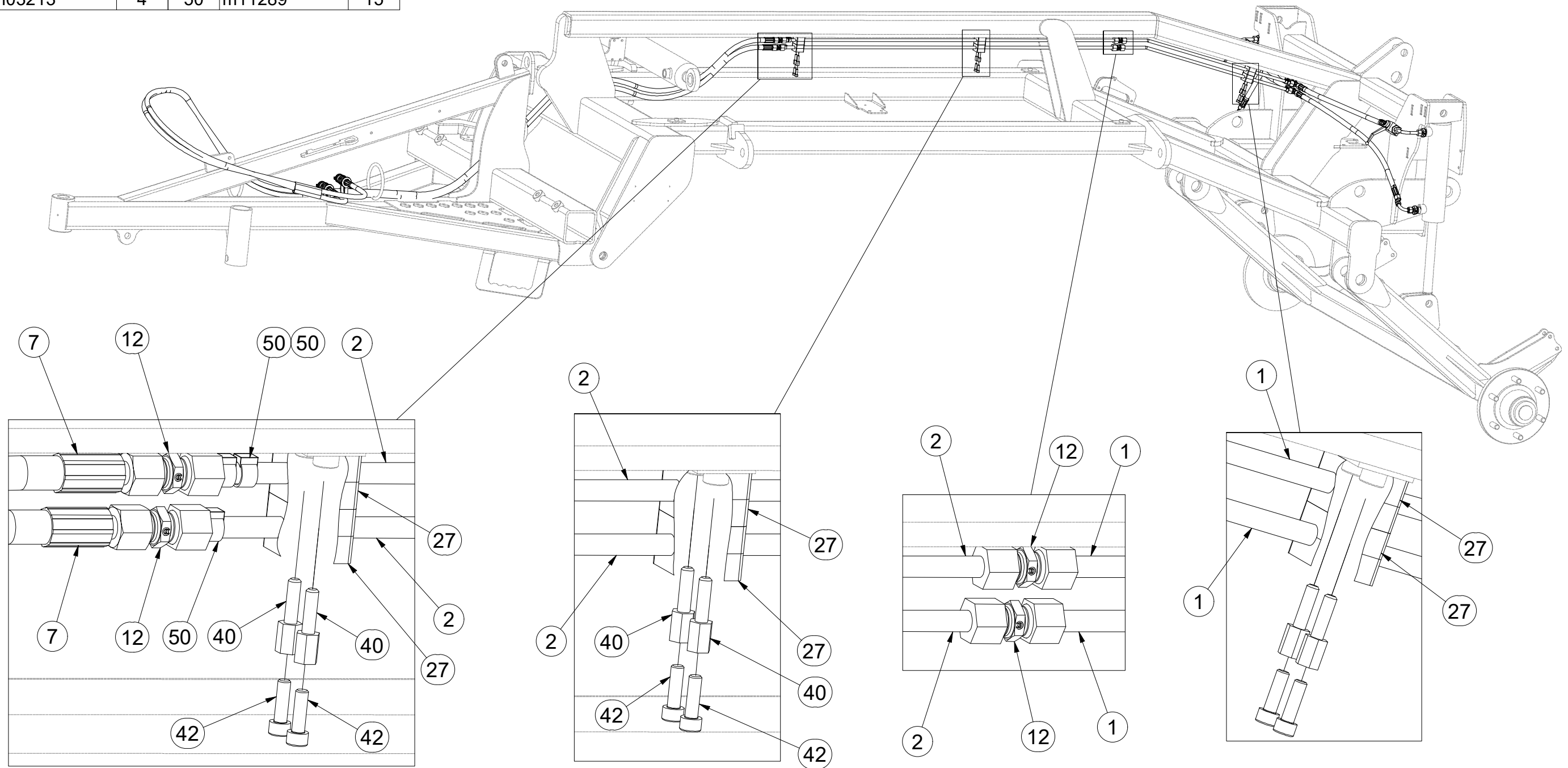

ⒸZ HYDRAULIKA STROJE

Ⓓ HYDRAULIK DER MASCHINE

Ⓕ HYDRAULIQUE DE LA MACHINE

ⒼB MACHINE HYDRAULICS

ⒺU ГИДРАВЛИКА МАШИНЫ

ⒻL HYDRAULIKA MASZYNY



3012561

Pos.	Part Number	Pcs.	Pos.	Part Number	Pcs.
1	m10541	2	14	m09934	4
3	m04623	2	15	m04024	3
5	m04761	2	22	m03849	4
6	m07909	2	24	m04023	2
7	m04087	4	28	m11183	2
11	m10493	2	50	m11289	15
13	m03889	2			

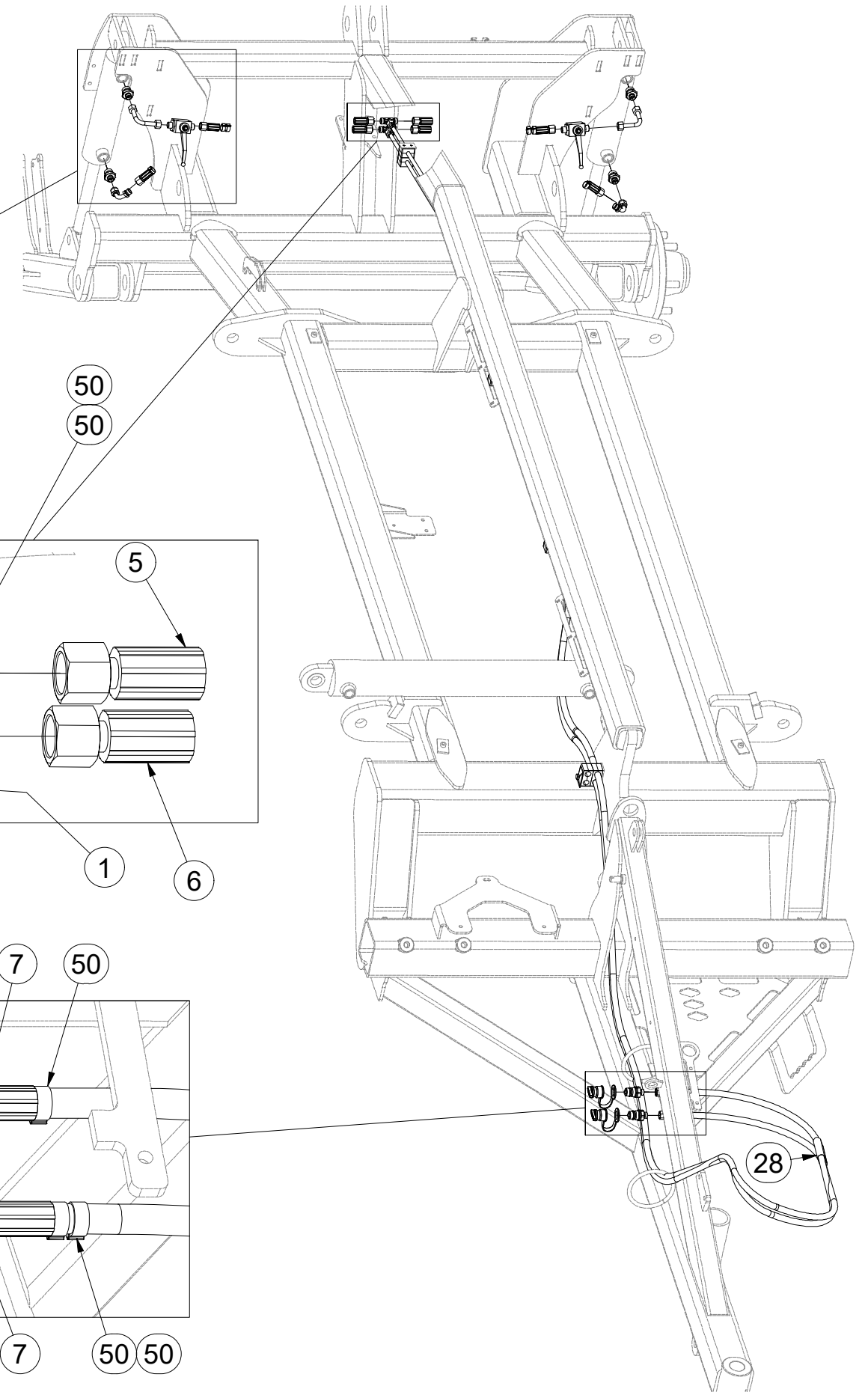
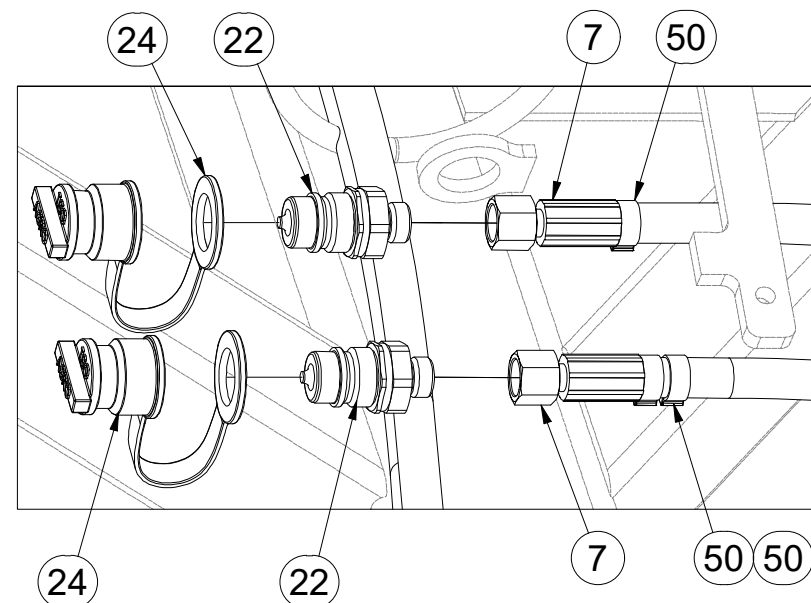
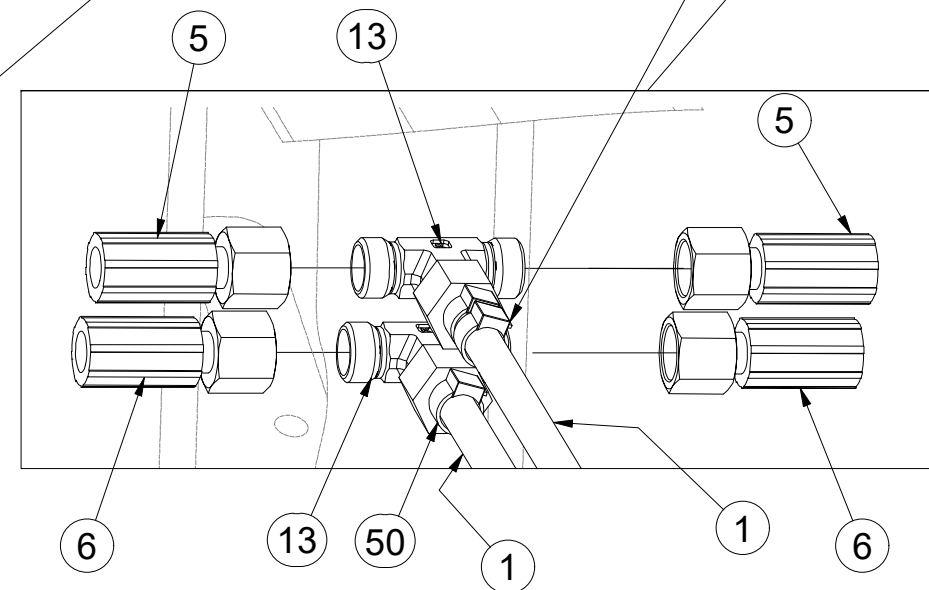
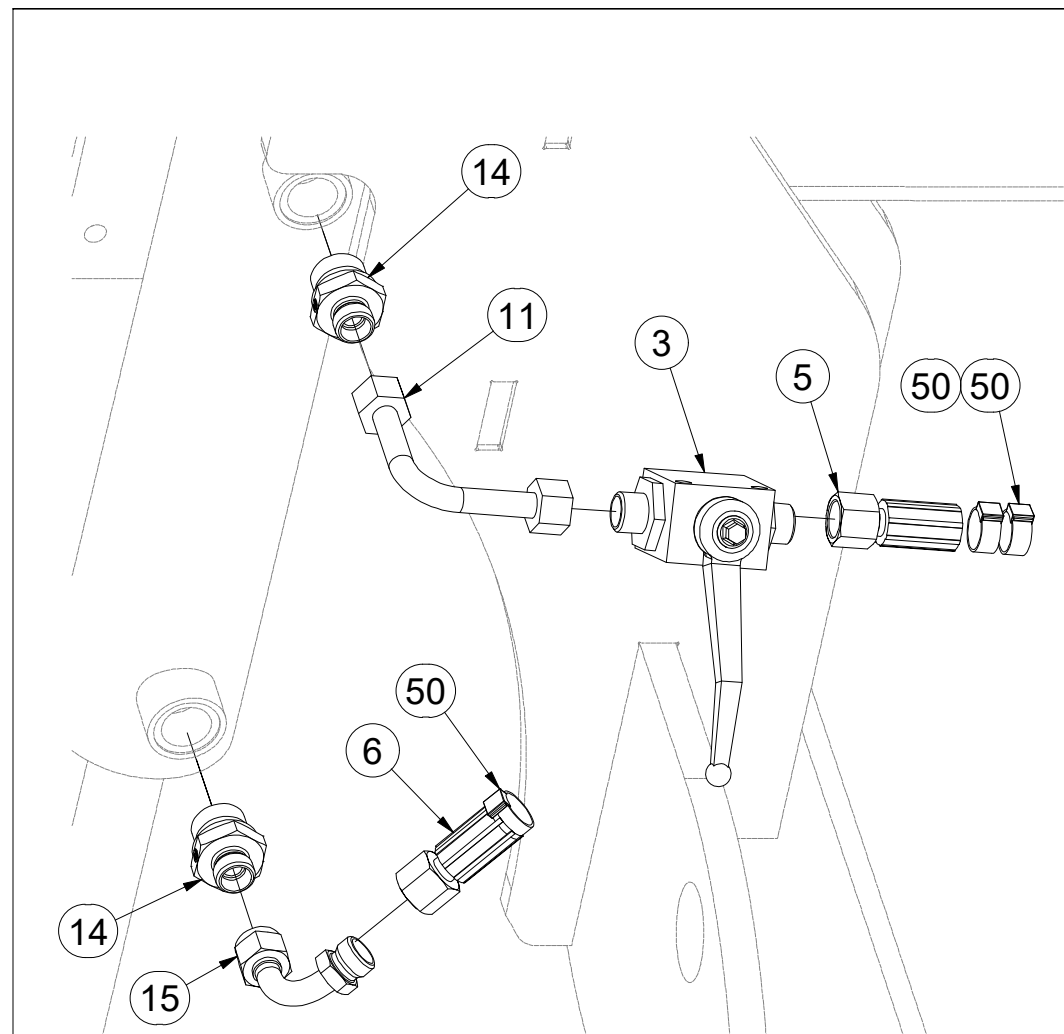

ⒸZ HYDRAULIKA STROJE

Ⓓ HYDRAULIK DER MASCHINE

Ⓕ HYDRAULIQUE DE LA MACHINE

ⒼB MACHINE HYDRAULICS

Ⓔ RU ГИДРАВЛИКА МАШИНЫ

Ⓗ PL HYDRAULIKA MASZYNY



3012561

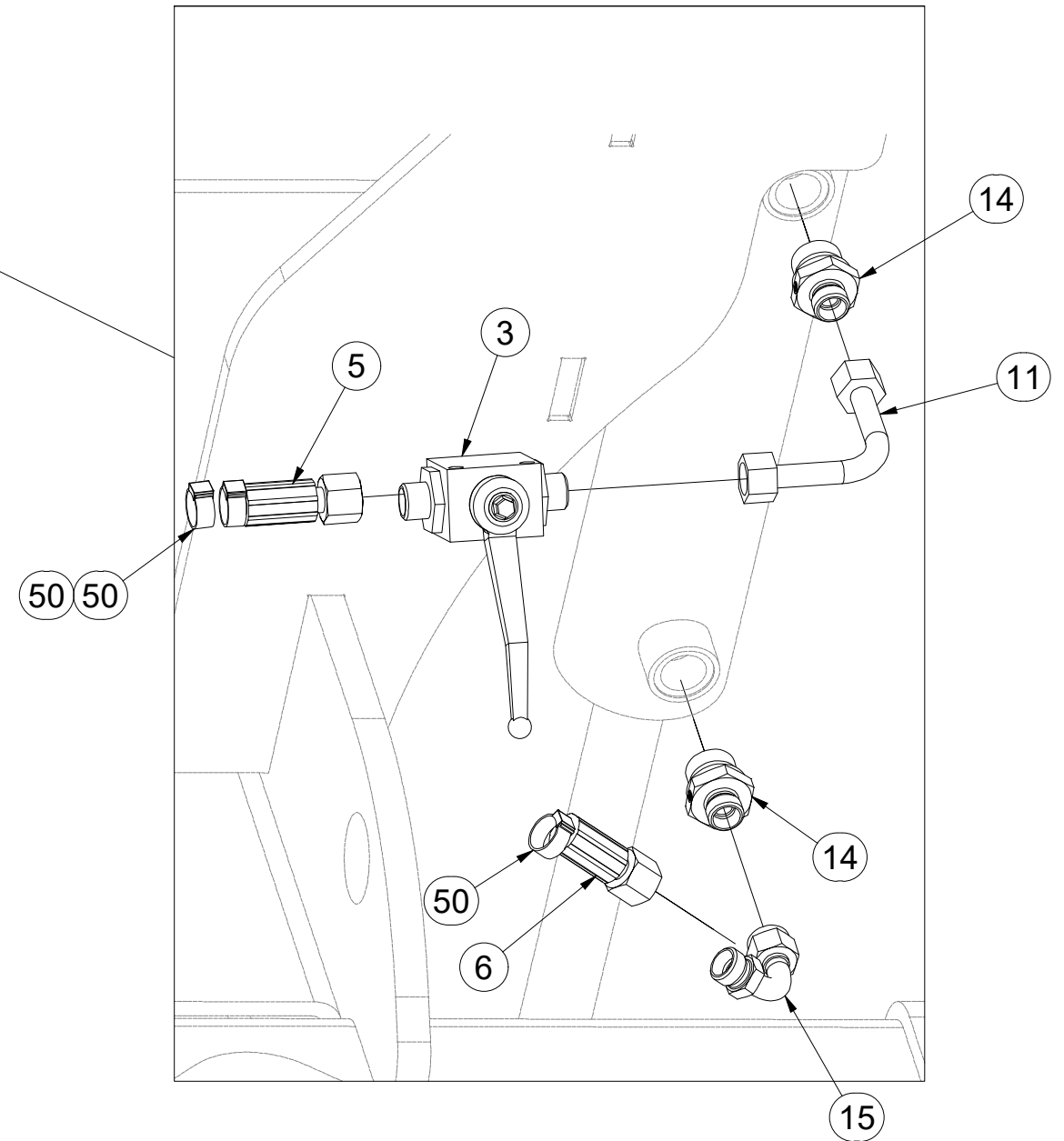
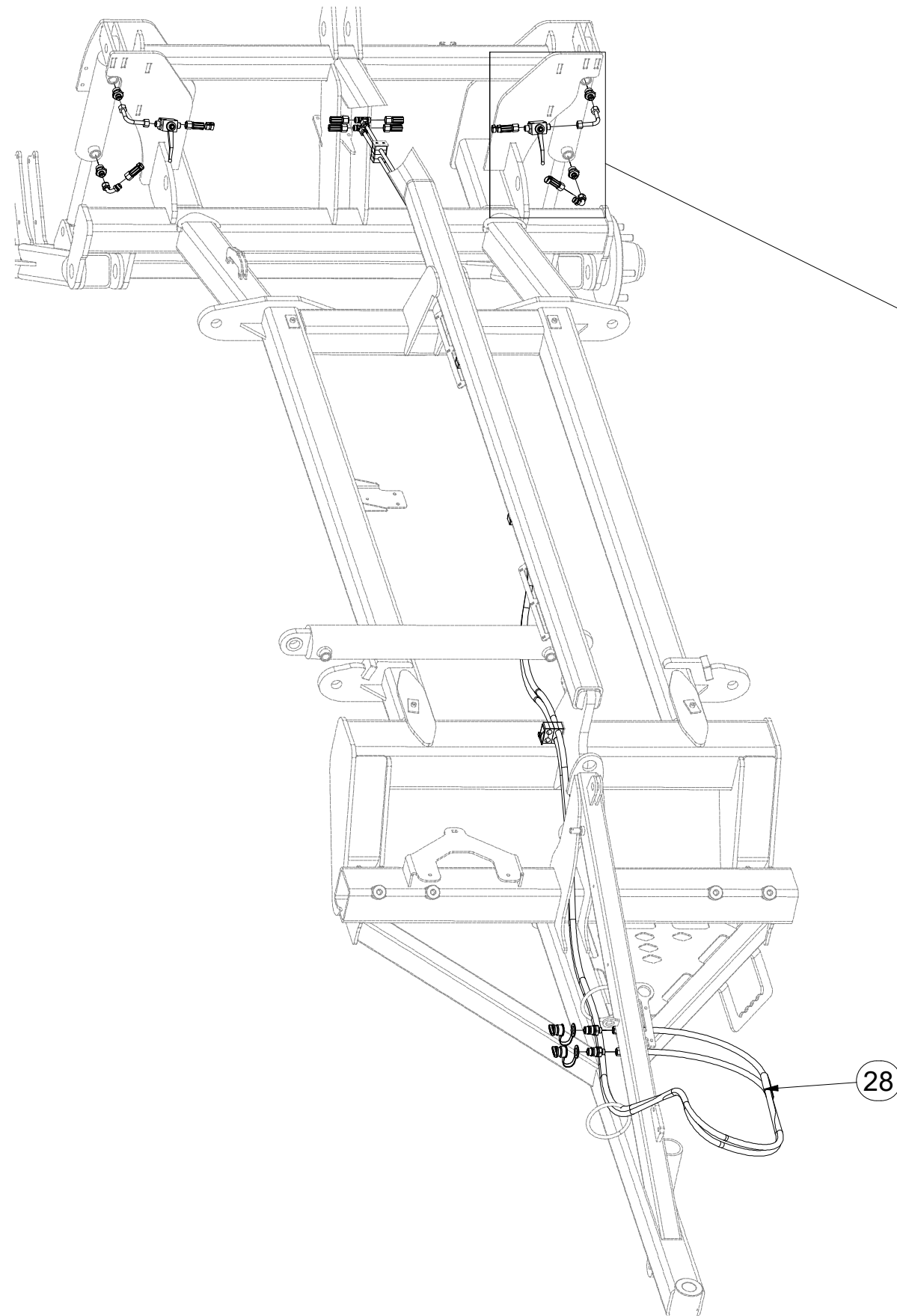

Pos.	Part Number	Pcs.	Pos.	Part Number	Pcs.
3	m04623	2	14	m09934	4
5	m04761	2	15	m04024	3
6	m07909	2	28	m11183	2
11	m10493	2	50	m11289	15

3012561

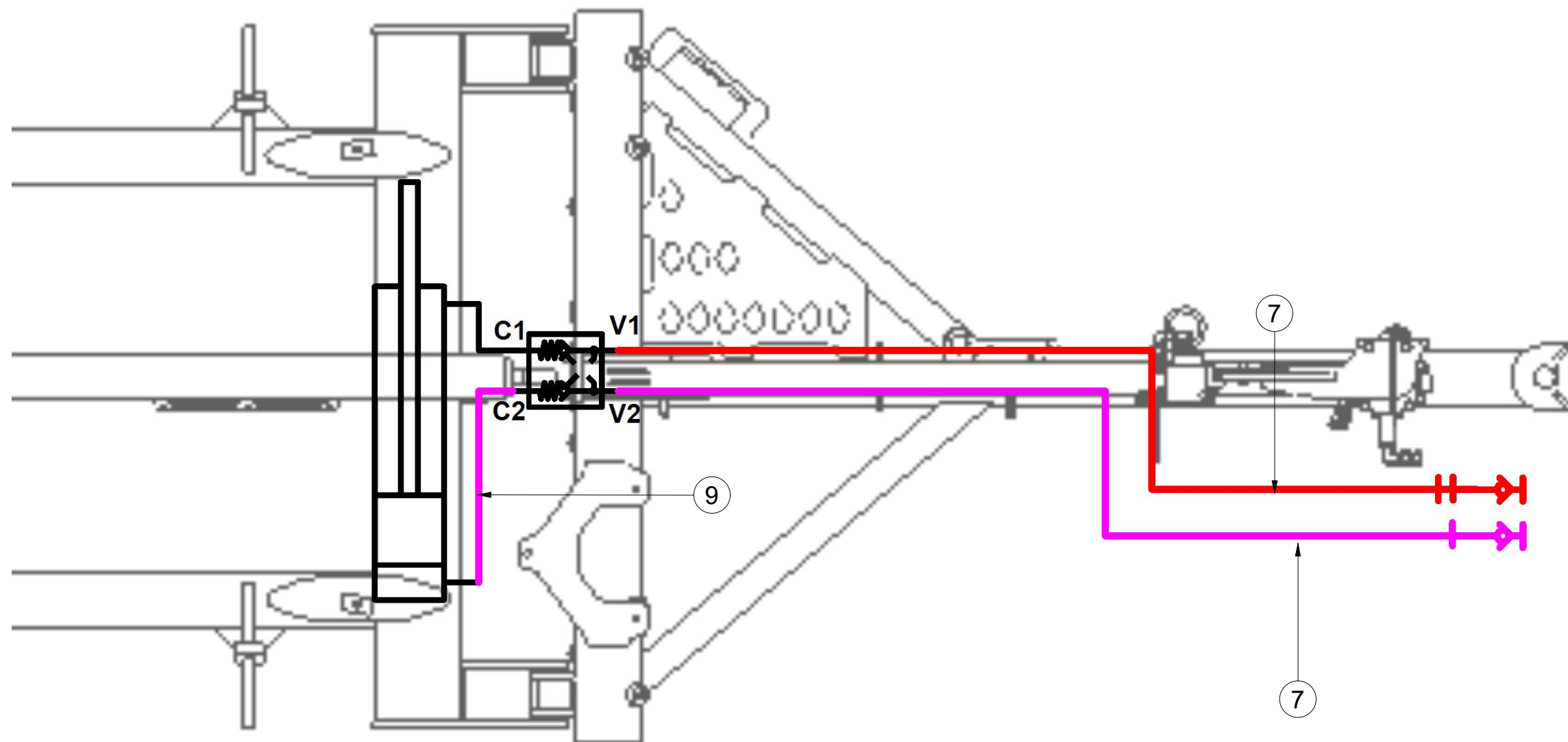

Pos.	Part Number	Pcs.
9	m03844	1
7	m04087	4

ⒸZ HYDRAULIKA STROJE

Ⓓ HYDRAULIK DER MASCHINE

Ⓕ HYDRAULIQUE DE LA MACHINE

ⒸB MACHINE HYDRAULICS

ⒸR ГИДРАВЛИКА МАШИНЫ

ⒸL HYDRAULIKA MASZYNY



3012561

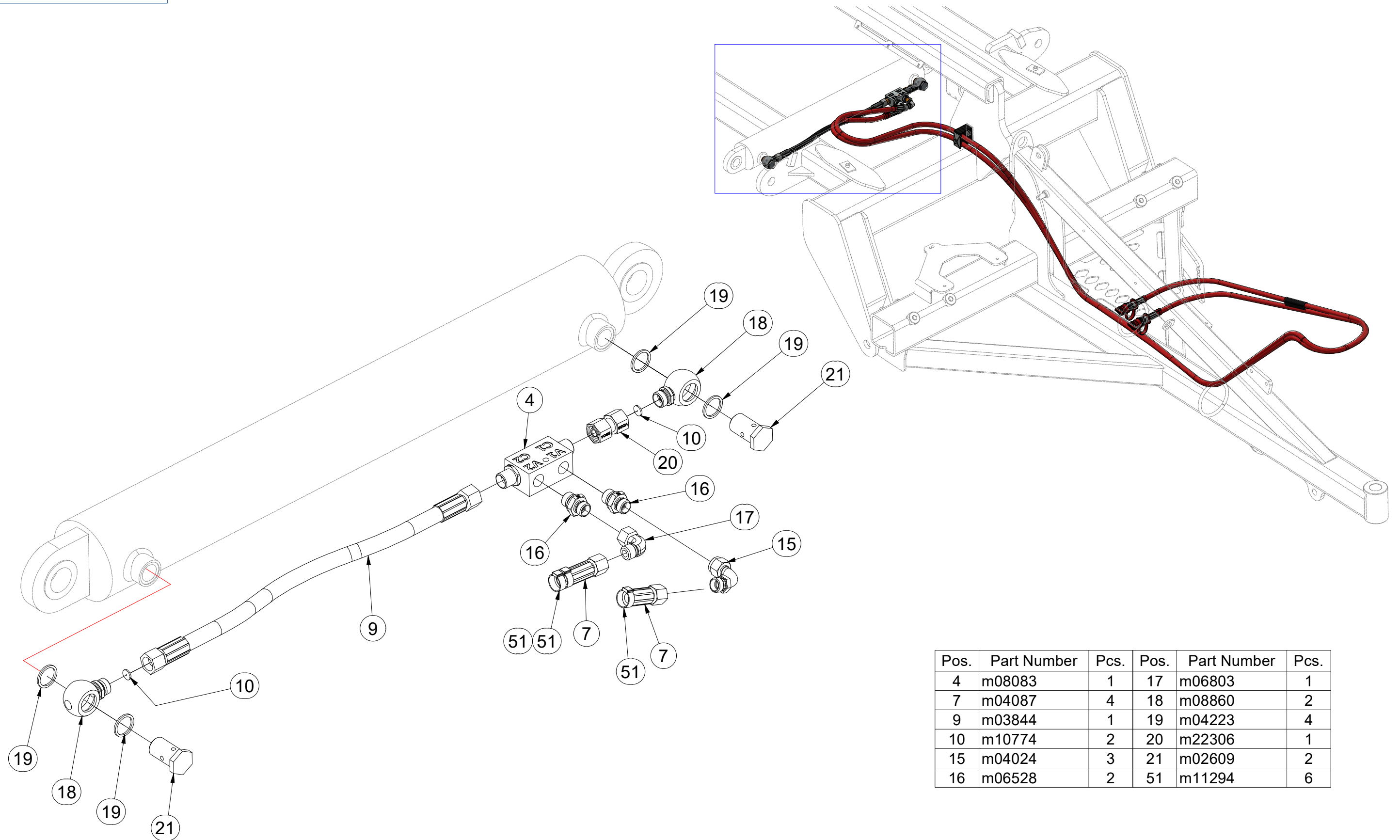

Pos.	Part Number	Pcs.	Pos.	Part Number	Pcs.
4	m08083	1	17	m06803	1
7	m04087	4	18	m08860	2
9	m03844	1	19	m04223	4
10	m10774	2	20	m22306	1
15	m04024	3	21	m02609	2
16	m06528	2	51	m11294	6

ⒸZ HYDRAULIKA STROJE

Ⓓ HYDRAULIK DER MASCHINE

Ⓕ HYDRAULIQUE DE LA MACHINE

ⒼB MACHINE HYDRAULICS

Ⓔ RU ГИДРАВЛИКА МАШИНЫ

Ⓗ PL HYDRAULIKA MASZYN



3012561

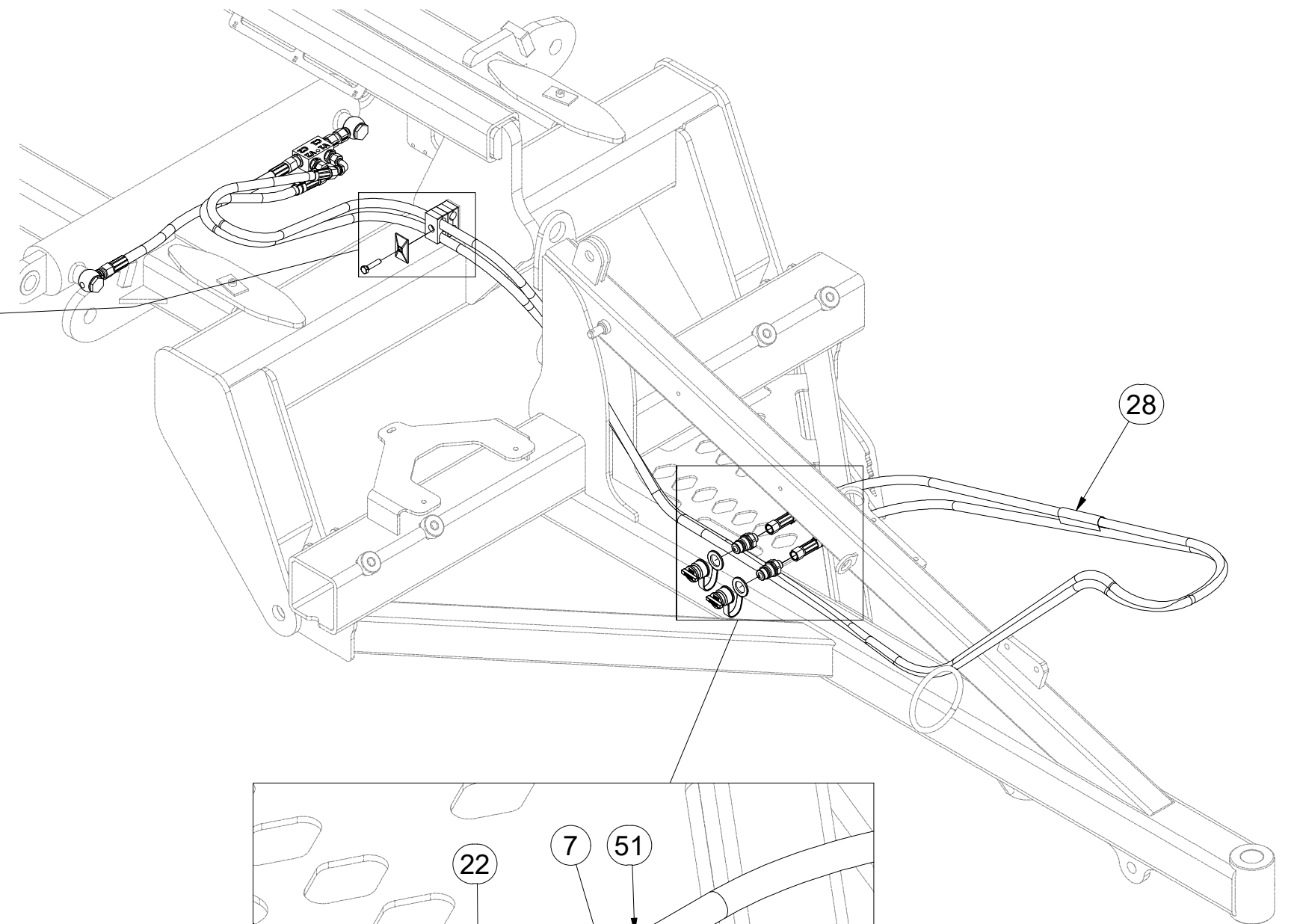
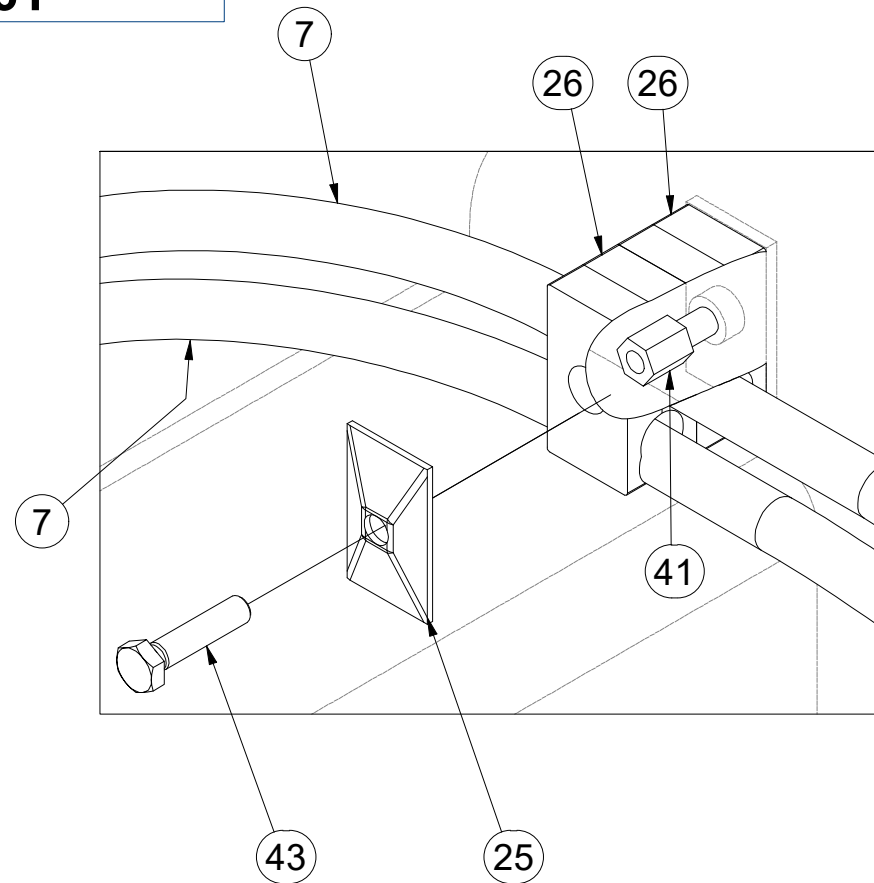

Pos.	Part Number	Pcs.
7	m04087	4
22	m03849	4
23	m04022	2
25	m04173	1
26	m04171	2
28	m11183	2
41	m04627	1
43	m01096	1
51	m11294	6

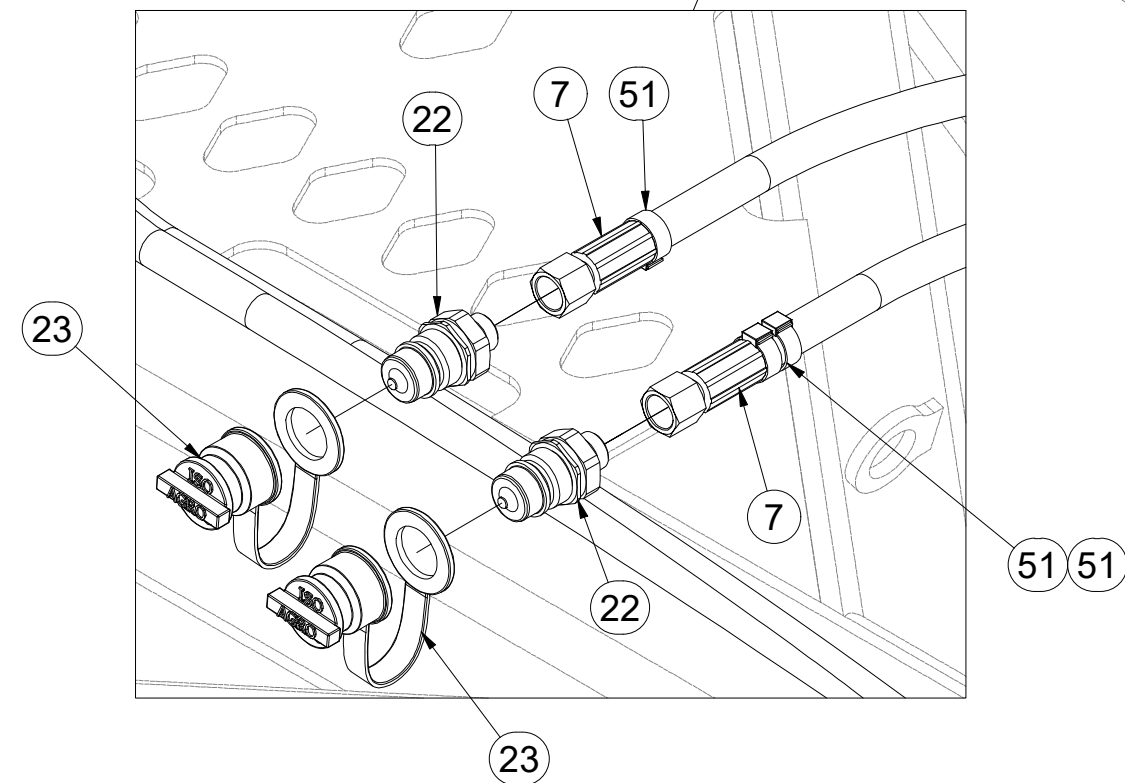

Ⓒ CZ OJ T3

Ⓓ DEICHSEL T3

Ⓕ TIMON T3

Ⓖ GB TOW BAR T3

Ⓡ RU ДЫШЛО T3

Ⓟ PL DYSZEL T3



VZ00023550

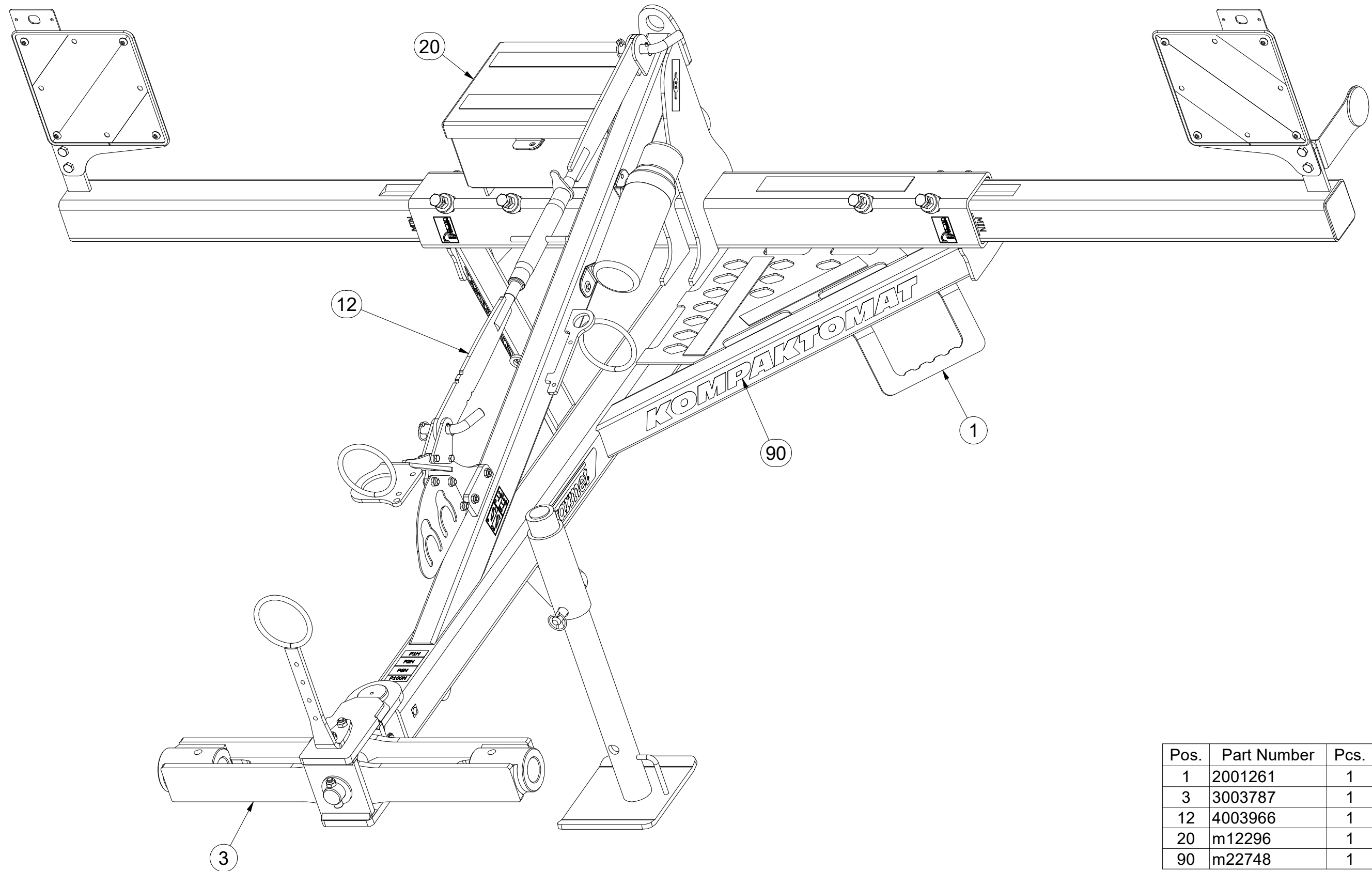

Pos.	Part Number	Pcs.
1	2001261	1
3	3003787	1
12	4003966	1
20	m12296	1
90	m22748	1

Ⓒ OJ T3

Ⓓ DEICHSEL T3

Ⓕ TIMON T3

Ⓖ TOW BAR T3

Ⓡ ДЫШЛО T3

Ⓢ DYSZEL T3



VZ00023550

Pos.	Part Number	Pcs.	Pos.	Part Number	Pcs.
2	3009637	1	31	m10454	3
3	3003787	1	41	m01097	2
7	8000647-40207	1	42	m04612	2
8	4014570	1	44	m03926	2
9	4008049	1	45	m14008	2
10	4012011	2	46	m03681	3
11	4012205	1	56	m04503	5
12	4003966	1	57	m04301	8
13	4003744	2	59	m03775	5
14	4019191	1	60	m02533	1
15	VZ00023251	1	72	m03866	1
16	4008679	1	73	4013139	2
18	4025416	2	80	m03959	1
19	4025417	2	85	m10451	1

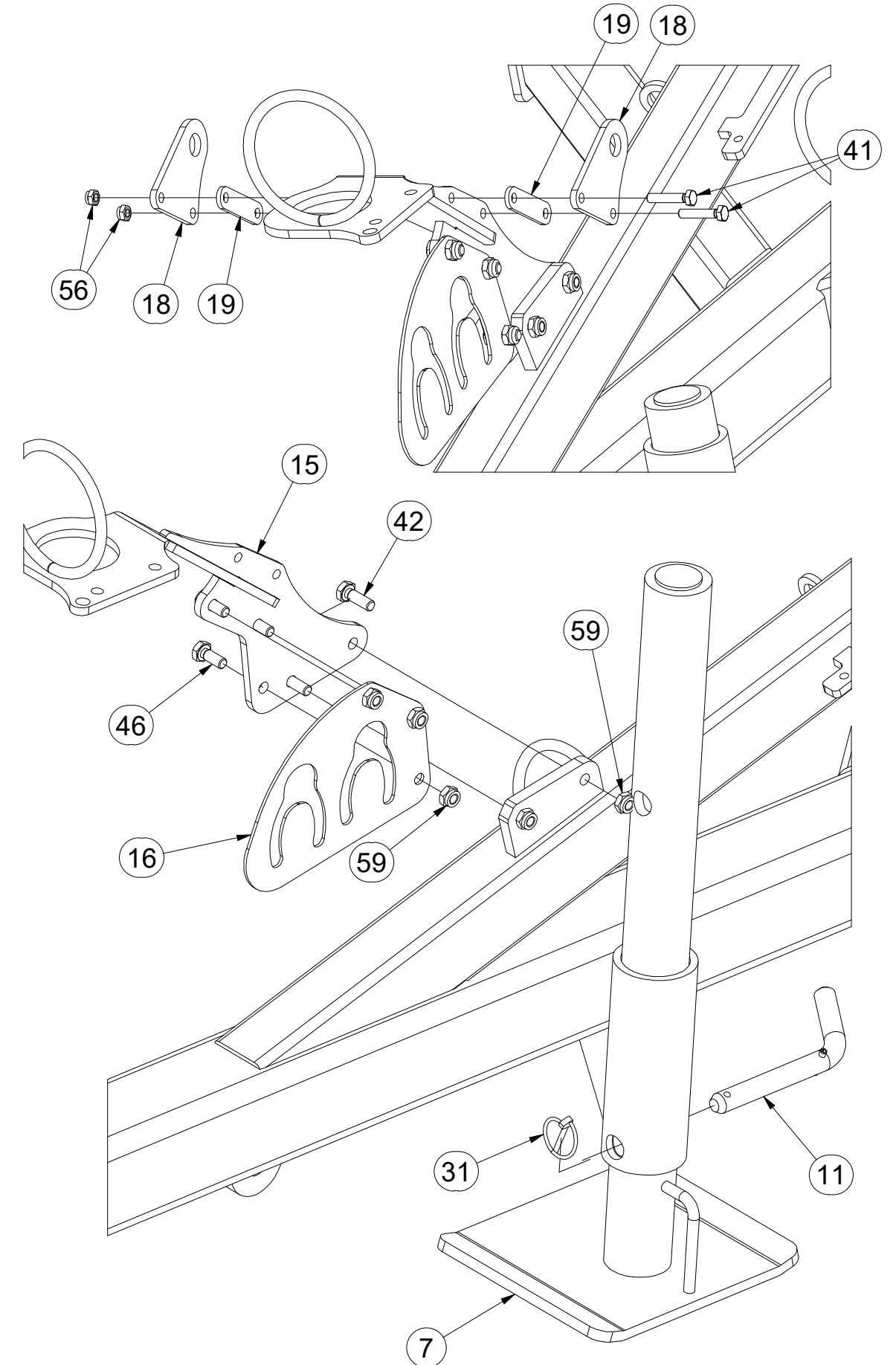
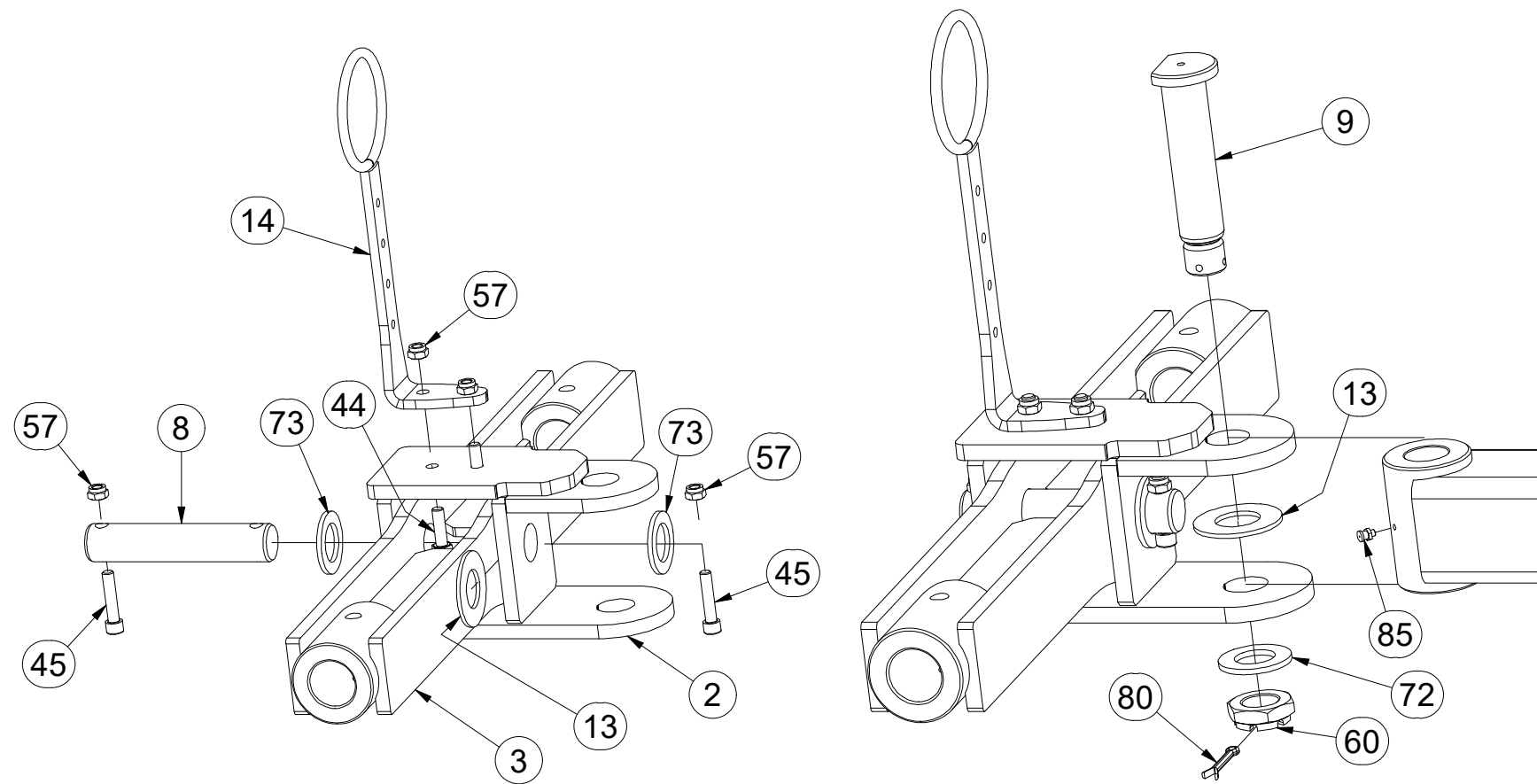

Ⓒ CZ OJ T3

Ⓓ DEICHSEL T3

Ⓕ TIMON T3

Ⓖ GB TOW BAR T3

Ⓡ RU ДЫШЛО T3

Ⓟ PL DYSZEL T3



VZ00023550

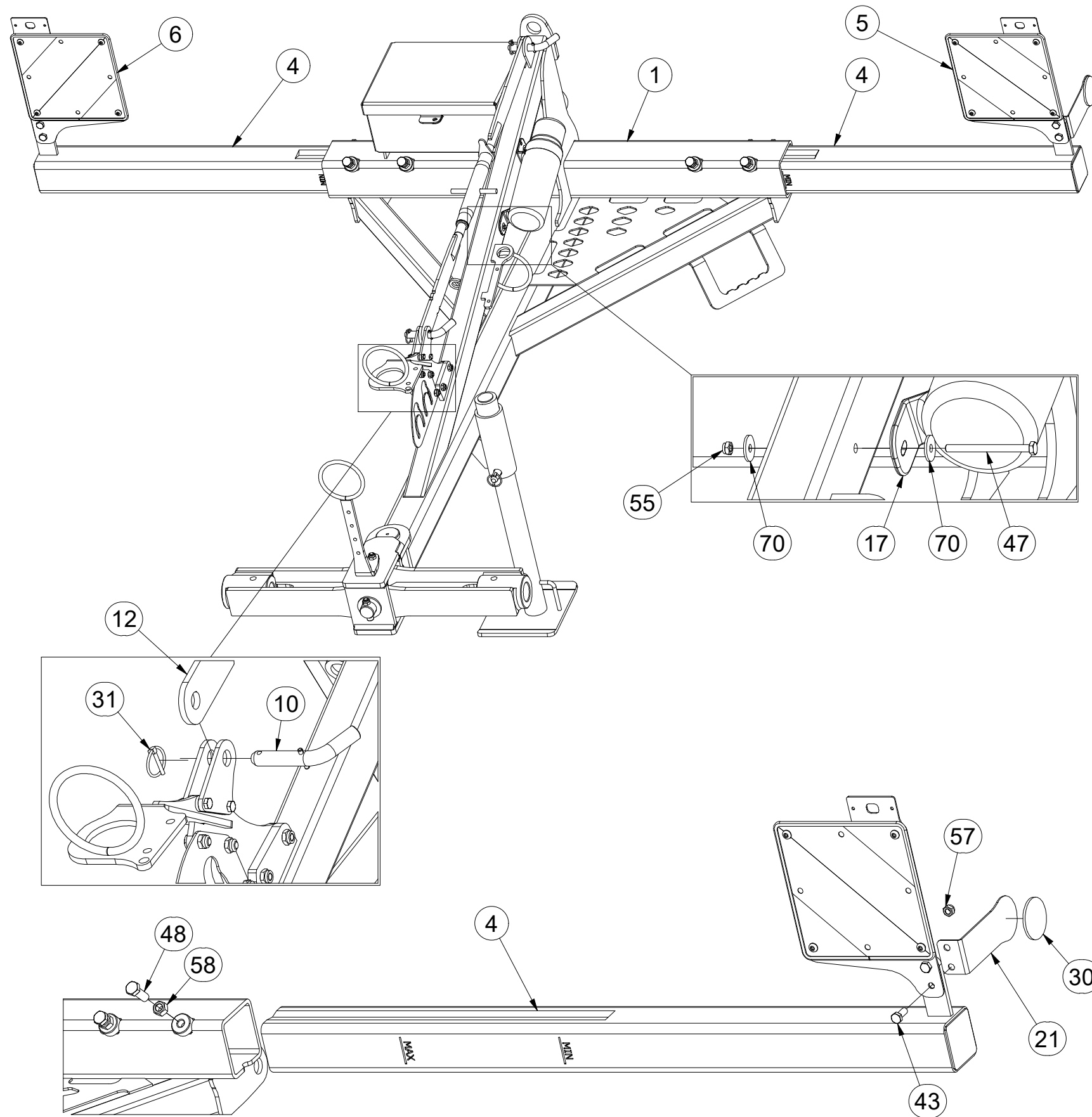

Pos.	Part Number	Pcs.	Pos.	Part Number	Pcs.
1	2001261	1	31	m10454	3
4	4019255	2	40	m01092	3
5	VZ00024252	1	43	m04039	4
6	VZ00024253	1	47	m16453	2
10	4012011	2	48	m02254	4
12	4003966	1	55	m05560	2
17	m15900	1	56	m04503	5
20	m12296	1	57	m04301	8
21	VZ00023540	2	58	m01306	4
30	m02579	2	70	m16612	4
			71	m07936	3

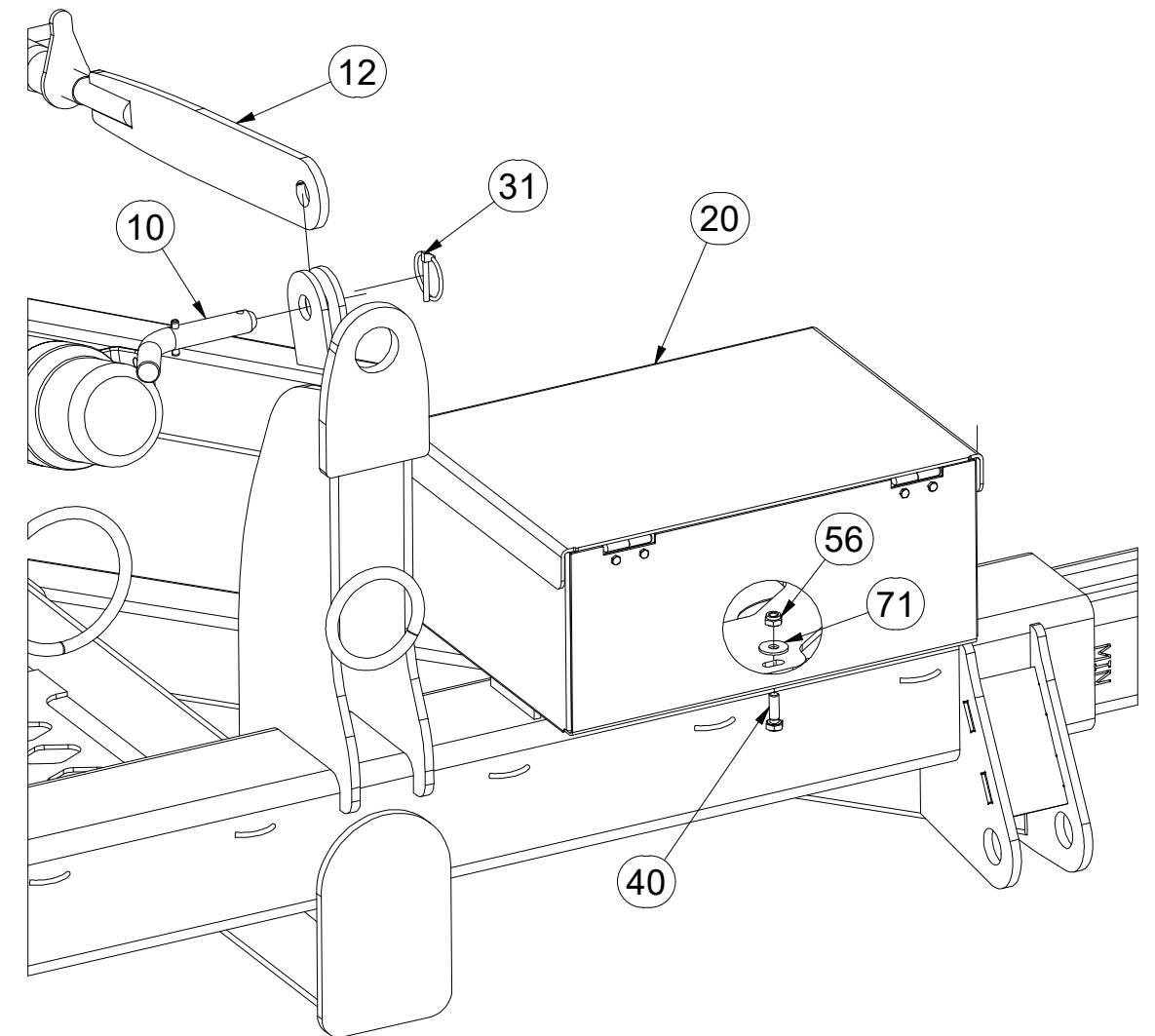

Ⓒ CZ OJ T3

Ⓓ DEICHSEL T3

Ⓕ TIMON T3

Ⓖ GB TOW BAR T3

Ⓡ RU ДЫШЛО T3

Ⓟ PL DYSZEL T3



m22748

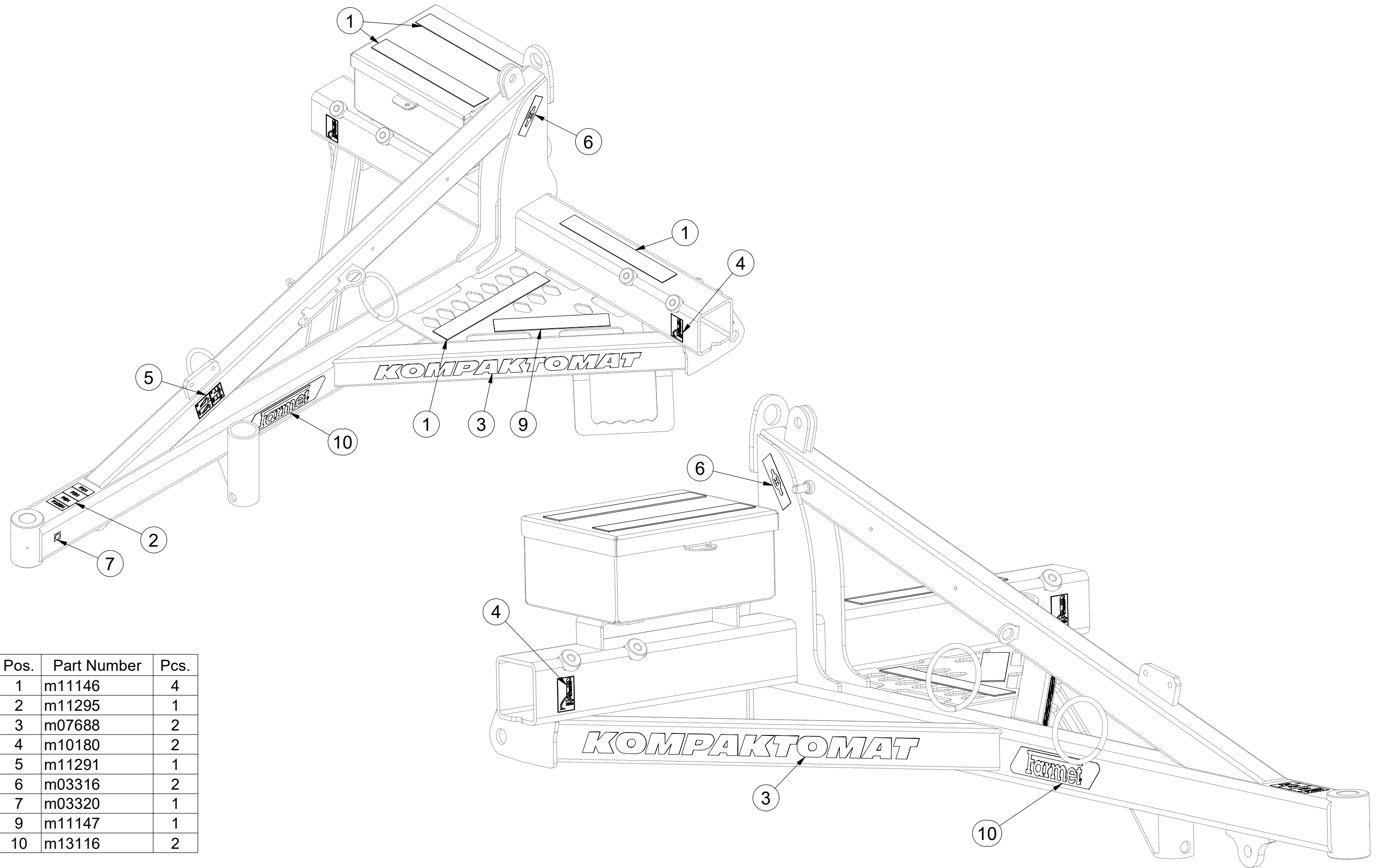

Pos.	Part Number	Pcs.
1	m11146	4
2	m11295	1
3	m07688	2
4	m10180	2
5	m11291	1
6	m03316	2
7	m03320	1
9	m11147	1
10	m13116	2

Ⓒ SPOJOVACÍ TÁHLO
Ⓓ VERBINDUNGSSTANGE
Ⓕ TIGE DE RACCORDEMENT

Ⓖ CONNECTING ROD
Ⓡ СОЕДИНИТЕЛЬНАЯ ТЯГА
Ⓟ KORBOWÓD



4003966

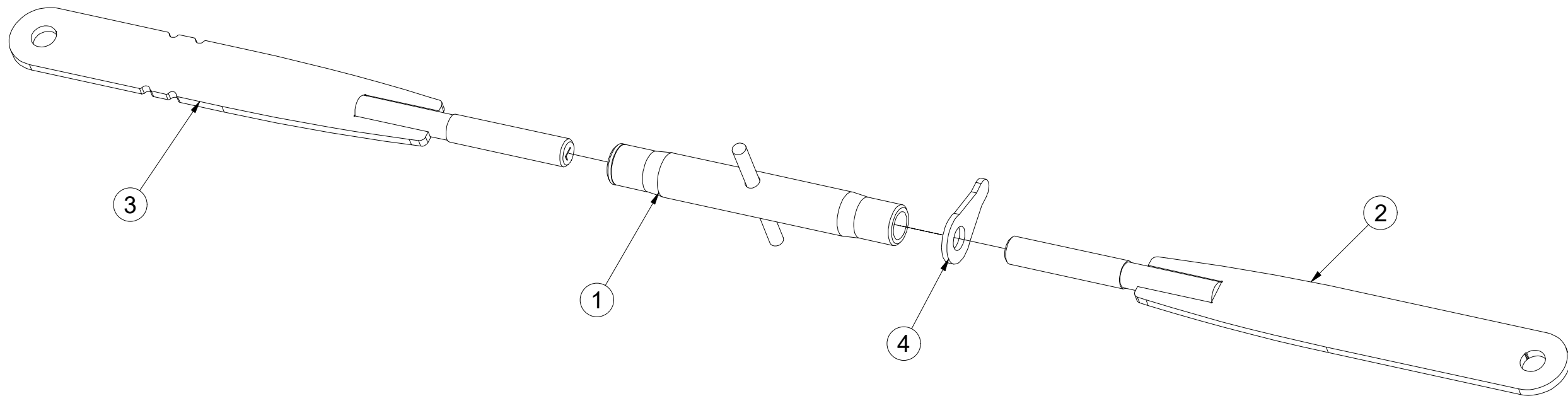
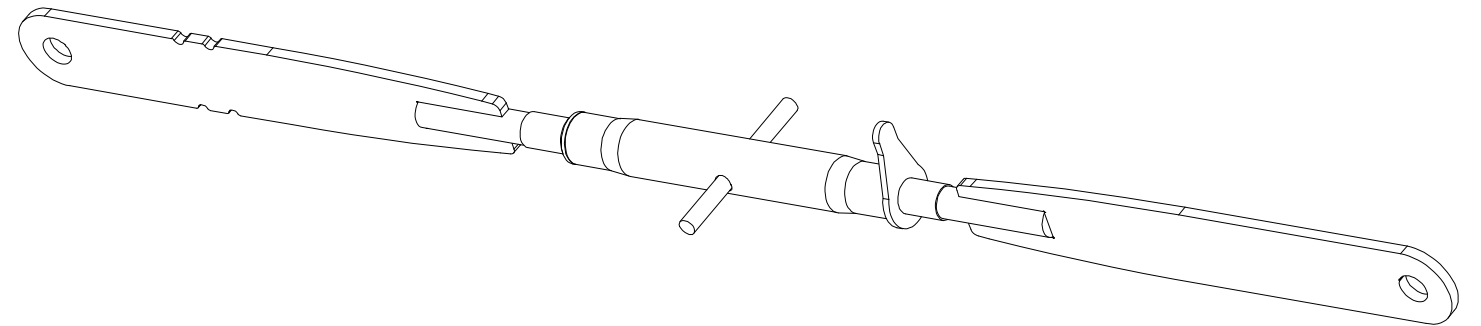

Pos.	Part Number	Pcs.
1	m08880	1
2	4023421	1
3	4023423	1
4	m08881	1

☞ SADA ČEPŮ TBZ 3

☞ BOLZENSATZ TBZ 3

☞ KIT D'EMBOUITS TBZ 3

3011605

☞ SET OF TBZ 3 PINS

☞ КОМПЛЕКТ ПАЛЬЦЕВ TBZ 3

☞ ZESTAW CZOPÓW TBZ 3

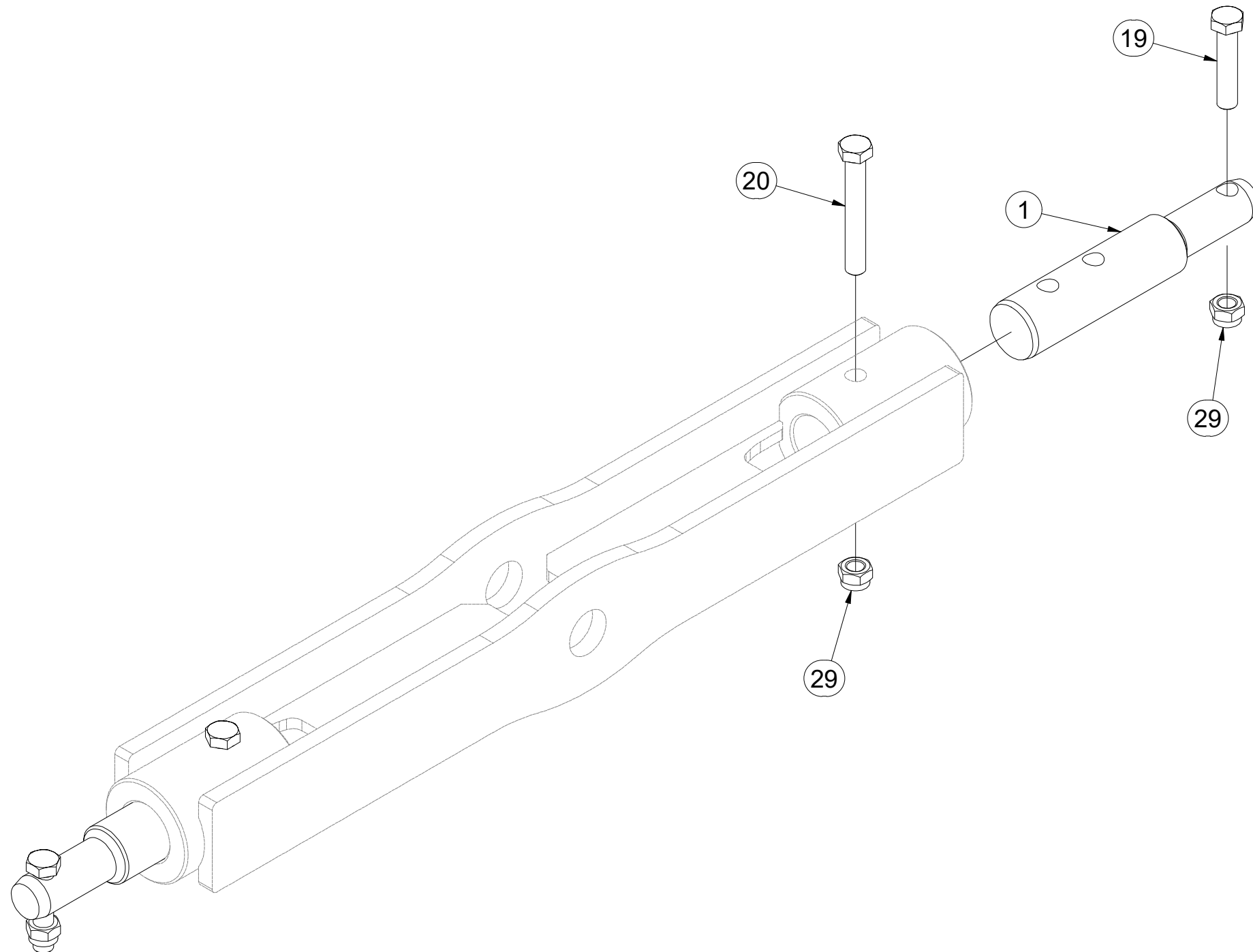
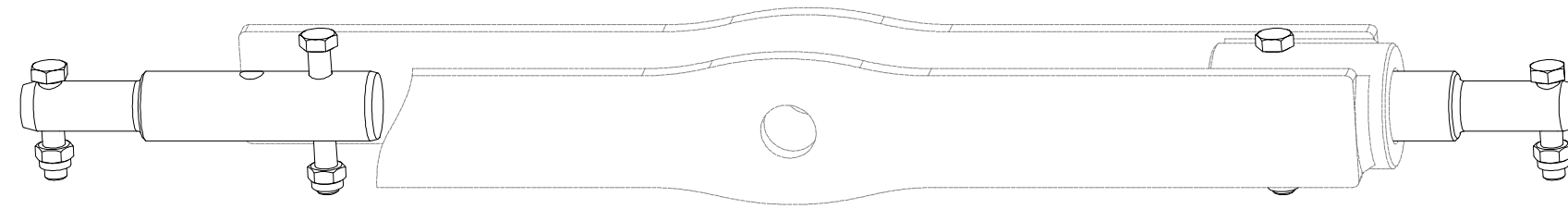

Pos.	Part Number	Pcs.
1	VZ00022884	2
19	m01133	2
20	m02970	2
29	m03683	4

- ⒸZ TERČ PŘEDNÍ LEVÝ
- Ⓓ SCHILD, VORDERES, LINKES
- Ⓕ CIBLE AVANT GAUCHE

- ⒸB LEFT FRONT DISC
- ⒶЩИТОК ПЕРЕДНИЙ ЛЕВЫЙ
- Ⓐ PL TARCZA PRZEDNIA LEWA



VZ00024252

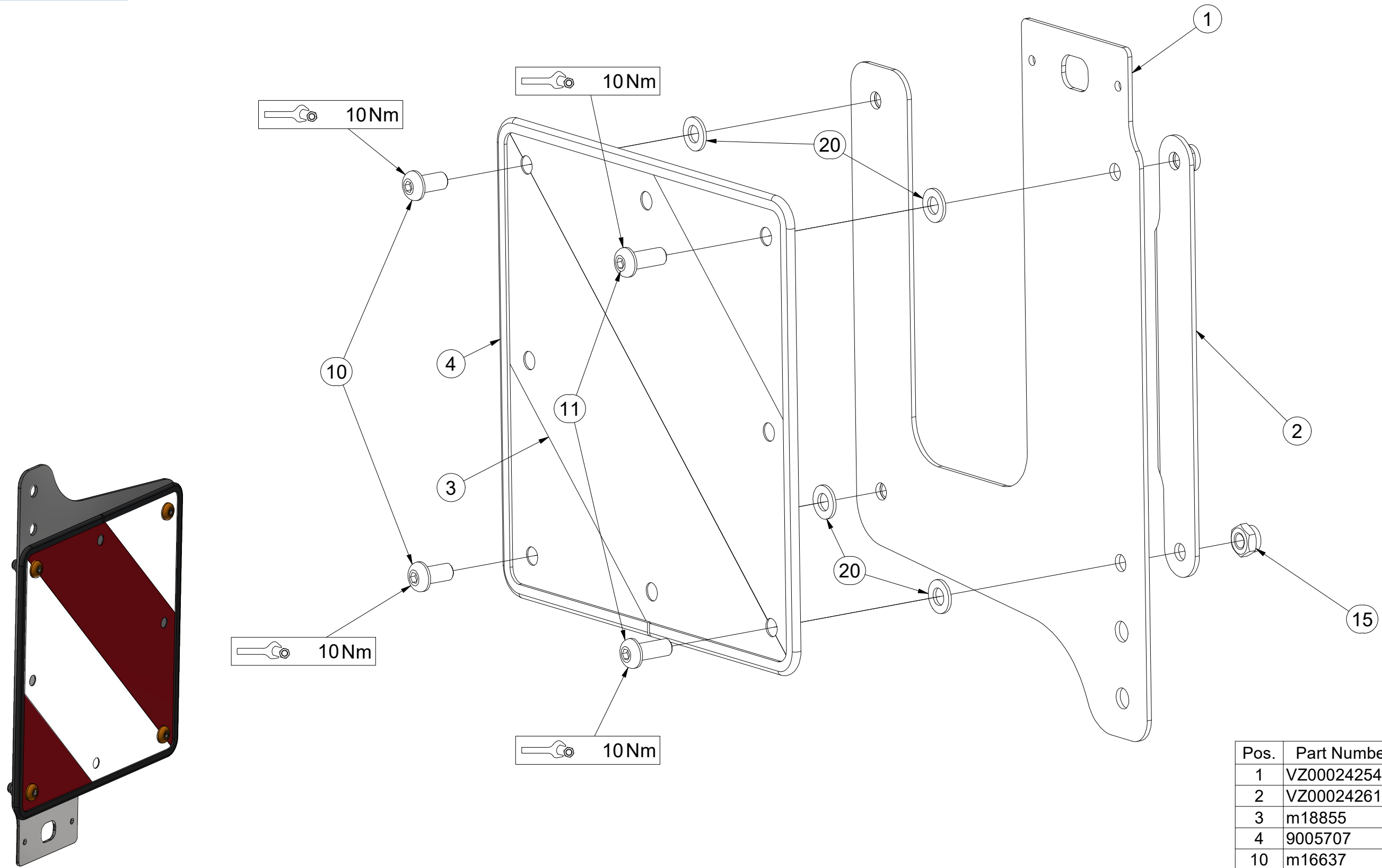

Pos.	Part Number	Pcs.
1	VZ00024254	1
2	VZ00024261	1
3	m18855	1
4	9005707	1
10	m16637	2
11	m16688	2
15	m03775	4
20	m01209	4

ⒸZ TERČ PŘEDNÍ PRAVÝ

Ⓓ SCHILD, VORDERES, RECHTES

Ⓕ CIBLE AVANT DROITE

ⒸB RIGHT FRONT DISC

ⒺЩИТОК ПЕРЕДНИЙ ПРАВЫЙ

Ⓖ TARCZA PRZEDNIA PRAWA



VZ00024253

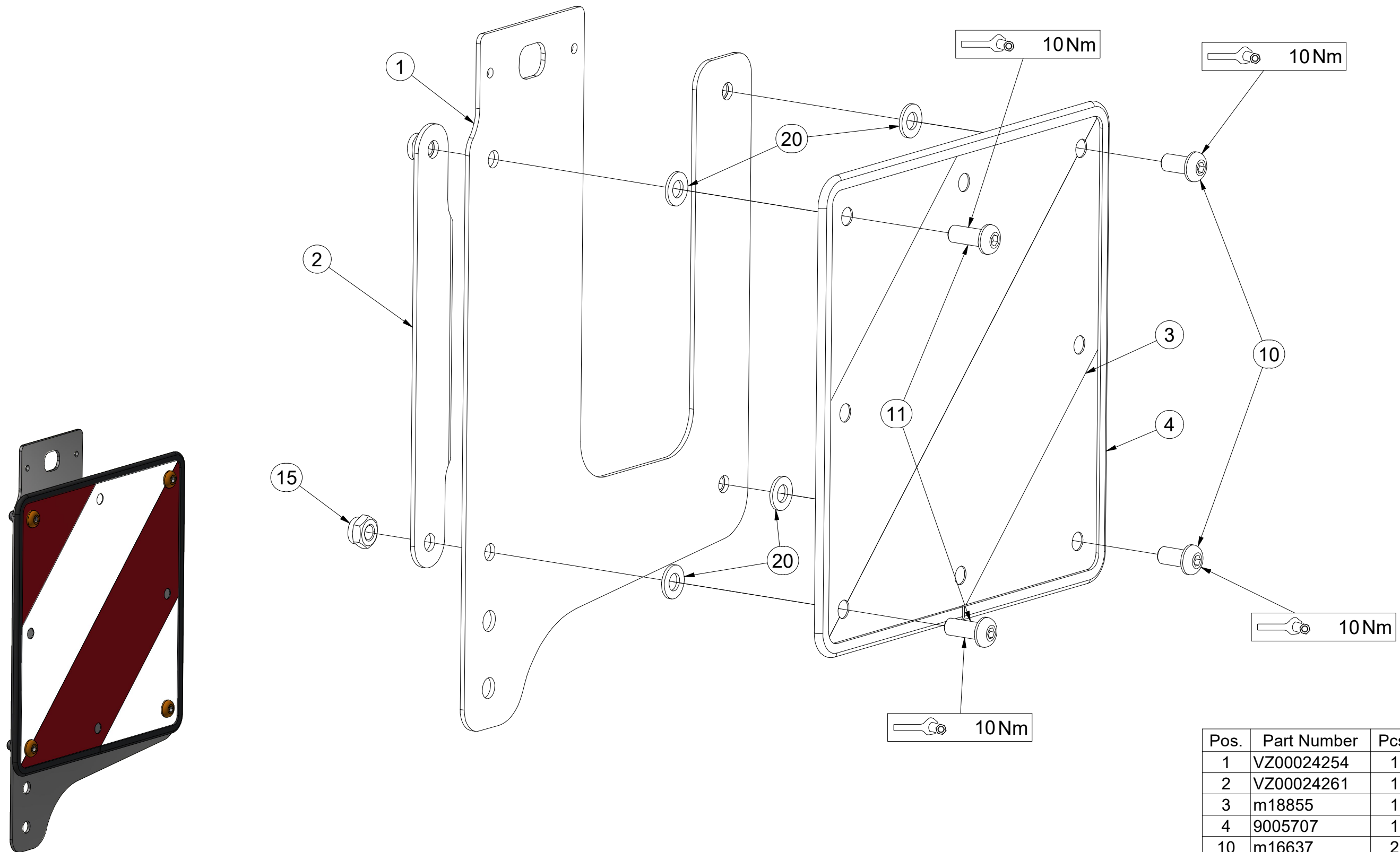

Pos.	Part Number	Pcs.
1	VZ00024254	1
2	VZ00024261	1
3	m18855	1
4	9005707	1
10	m16637	2
11	m16688	2
15	m03775	4
20	m01209	4

Ⓒ SADA KYPŘIČŮ STOP

Ⓓ SPURENLOCKERERSATZ

Ⓕ KIT DE CULTIVATEURS DE TRACES

3005535

Ⓖ SET OF TRACK CULTIVATORS

Ⓡ КОМПЛЕКТ РЫХЛИТЕЛЕЙ КОЛЕИ

Ⓟ ZESTAW SPULCHNIACZY ŚLADÓW

Farmet

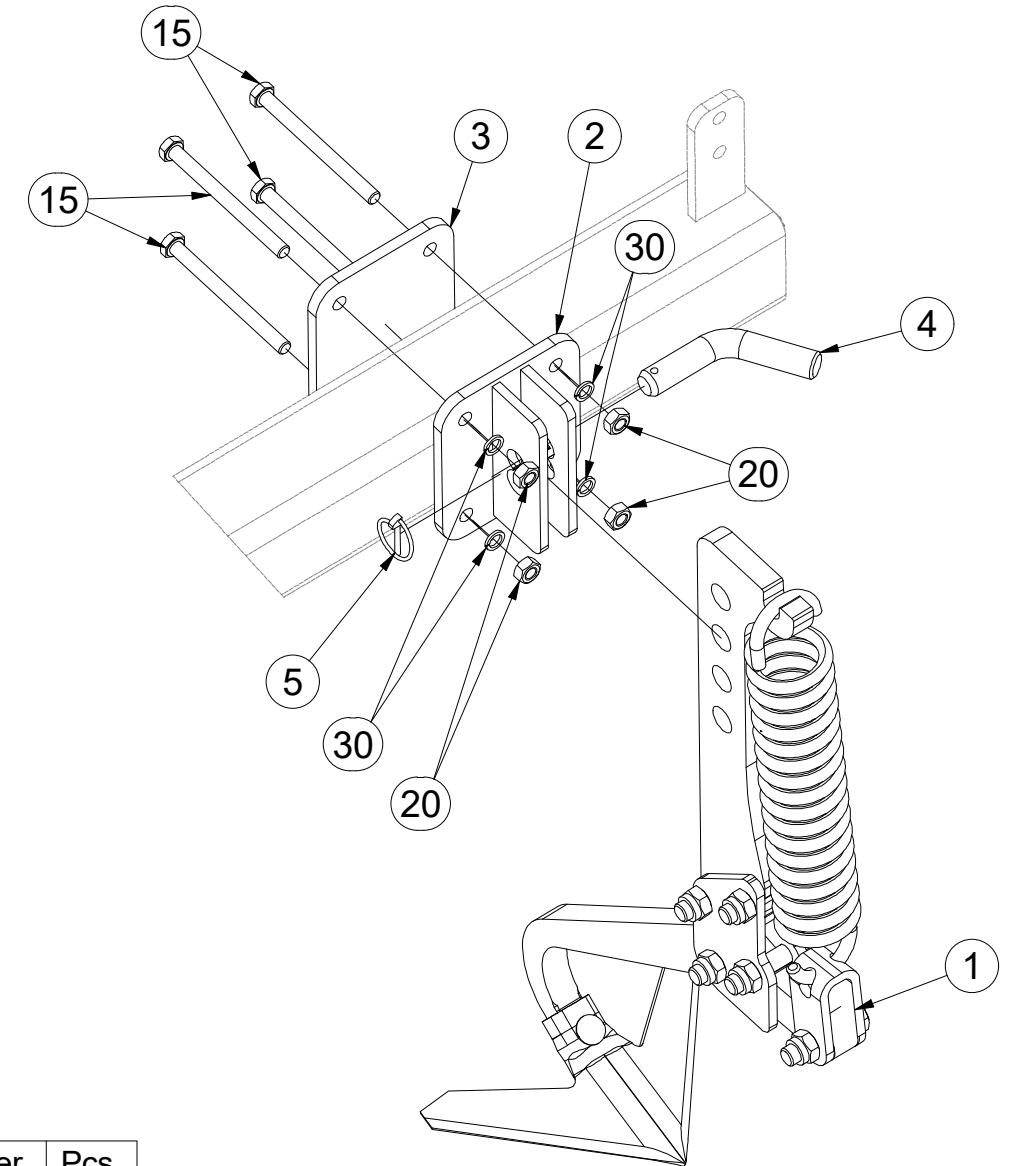
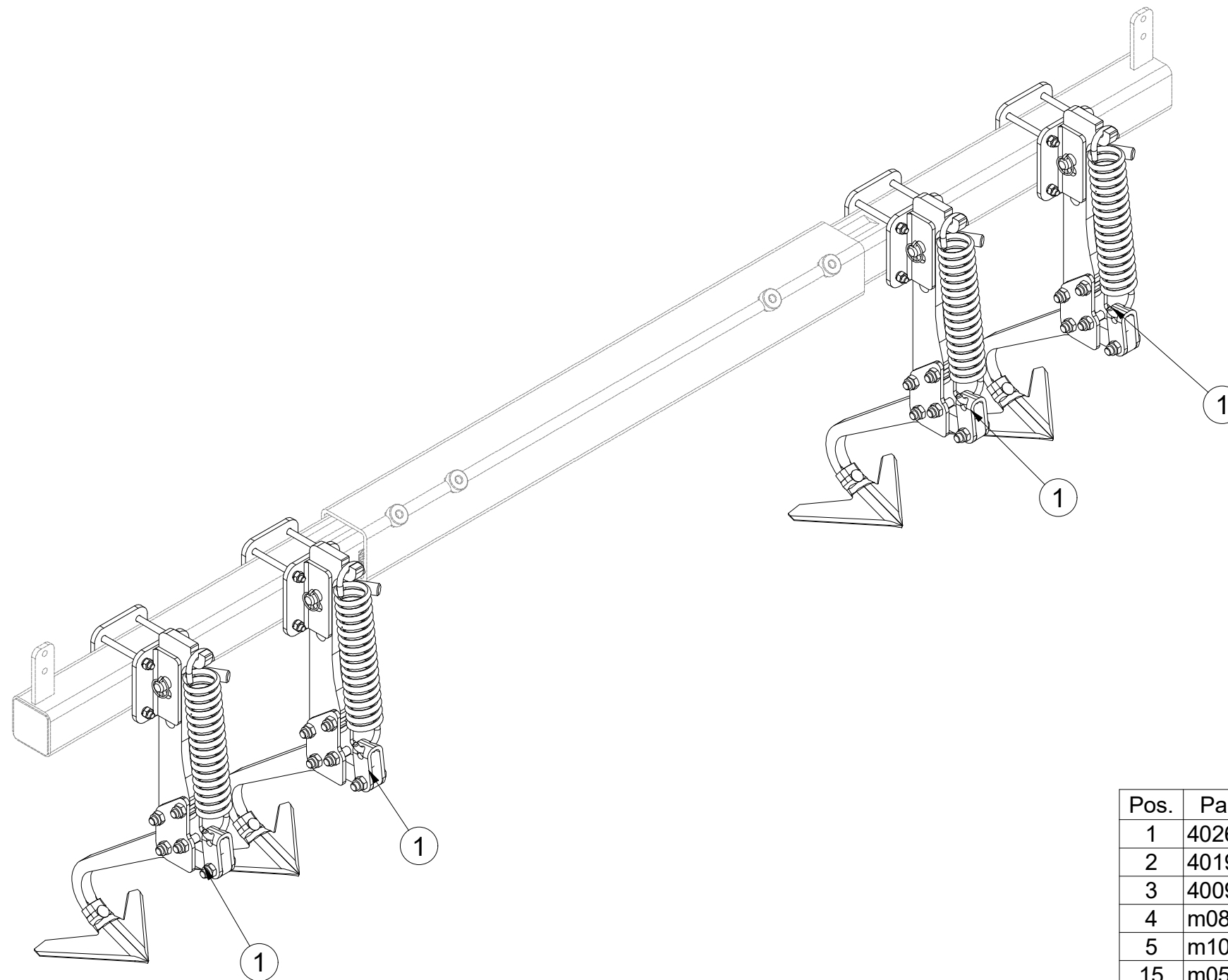

Pos.	Part Number	Pcs.
1	4026045	4
2	4019042	4
3	4009468	4
4	m08885	4
5	m10454	4
15	m05946	16
20	m01305	16
30	m03988	16

Ⓒ KYPŘIČ STOP

Ⓓ SPURENLOCKERER

Ⓕ CULTIVATEUR DES TRACES

Ⓖ TRACK CULTIVATOR

Ⓡ РЫХЛИТЕЛЬ КОЛЕИ

Ⓟ SPULCHNIARKA STÓP



4026045

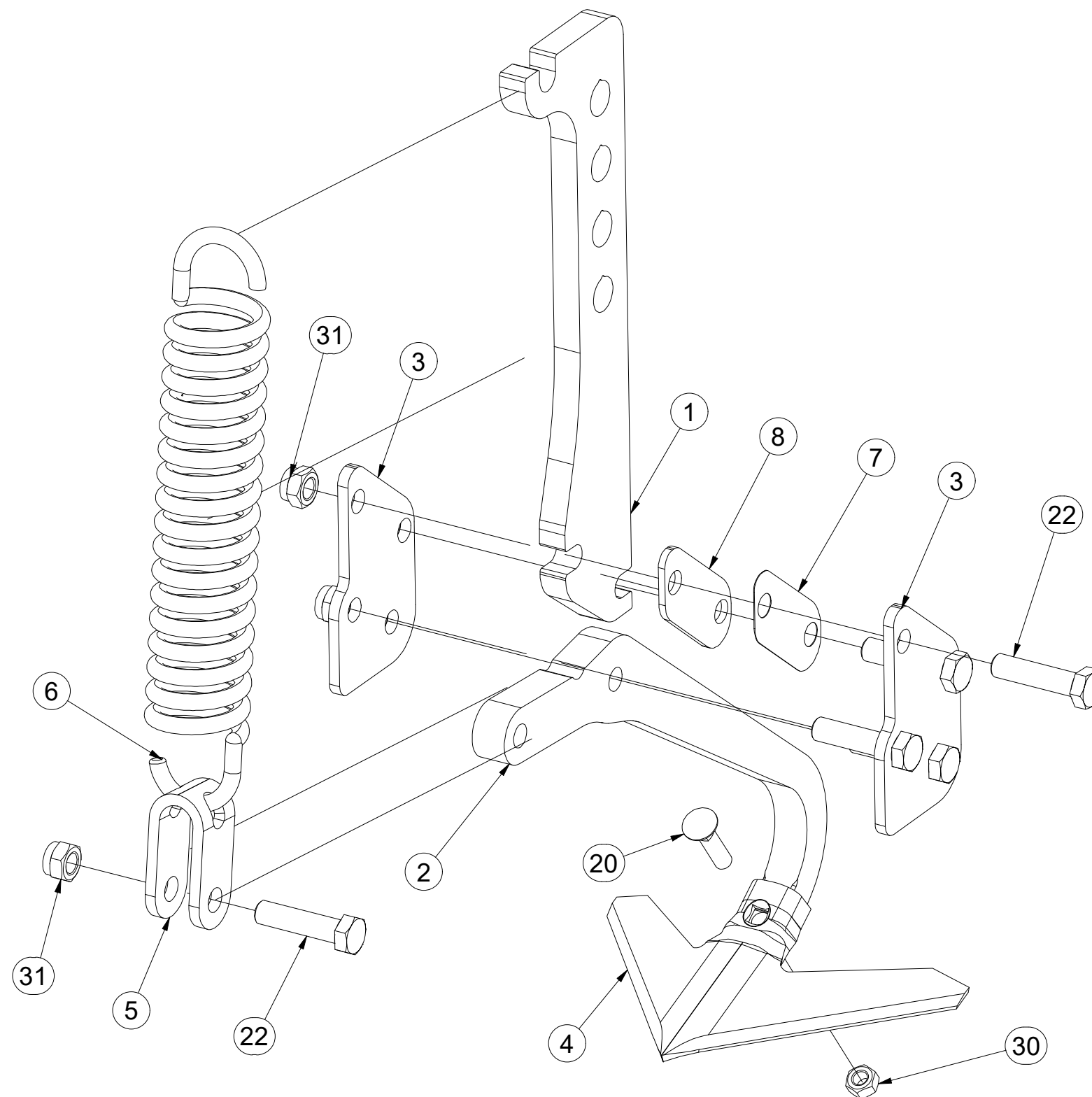
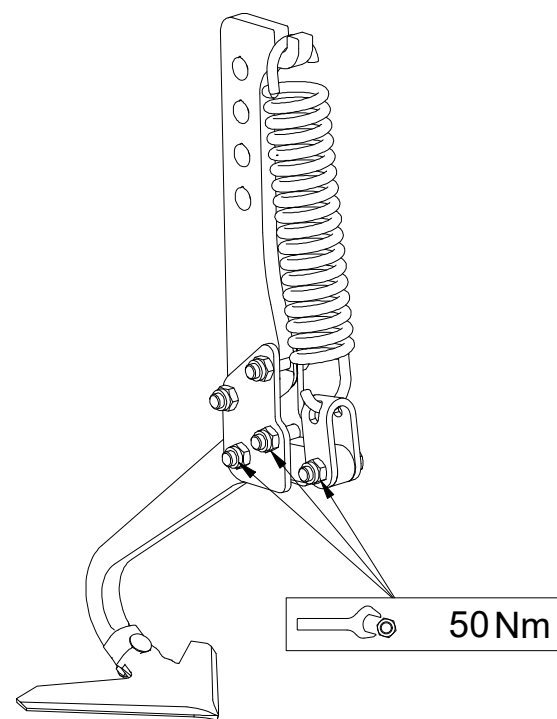

Pos.	Part Number	Pcs.
1	4017307	1
2	4025591	1
3	4005582	2
4	3000236-KOO	1
5	4005445	1
6	m02597	1
7	4005591	1
8	4026202	1
20	m10440	1
22	m06587	5
30	m10439	1
31	m03683	5

ⒸZ SADA PŘEDNÍCH SMYKŮ

Ⓓ SATZ VORDERE ACKERSCHLEPPEN

Ⓕ KIT DE NIVELEURS AVANT

ⒸB SET OF FRONT LEVELLING BARS

ⒸU КОМПЛЕКТ ПЕРЕДНИХ БОРОН

ⒸL ZESTAW PRZEDNICH WŁÓK

Farmet

3006409

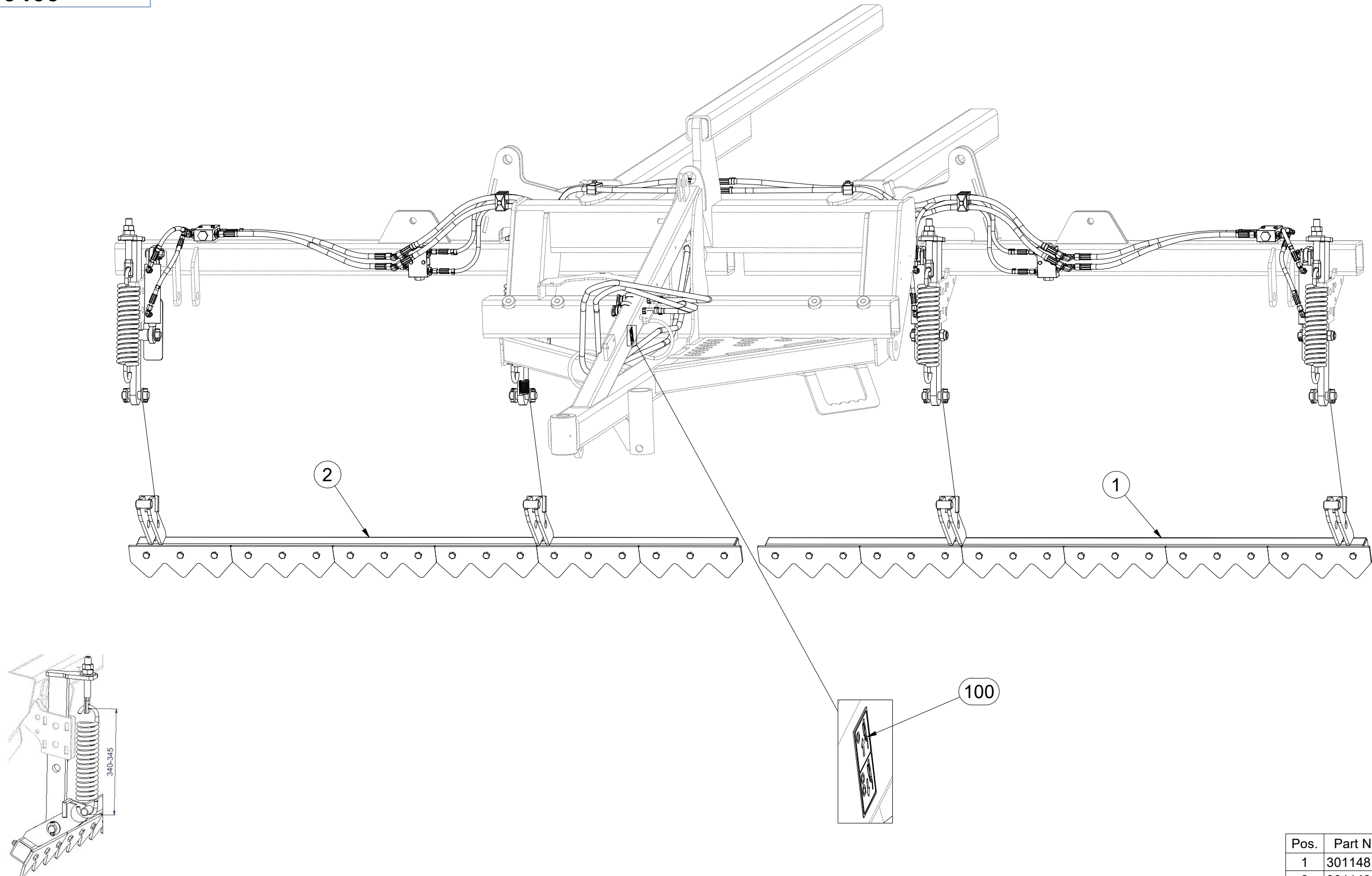

Pos.	Part Number	Pcs.
1	3011481	1
2	3011483	1
100	m11653	1

ⒸZ SADA PŘEDNÍCH SMYKŮ

Ⓓ SATZ VORDERE ACKERSCHLEPPEN

Ⓕ KIT DE NIVELEURS AVANT

ⒼB SET OF FRONT LEVELLING BARS

ⒺU КОМПЛЕКТ ПЕРЕДНИХ БОРОН

ⒼL ZESTAW PRZEDNICH WŁÓK



3006409

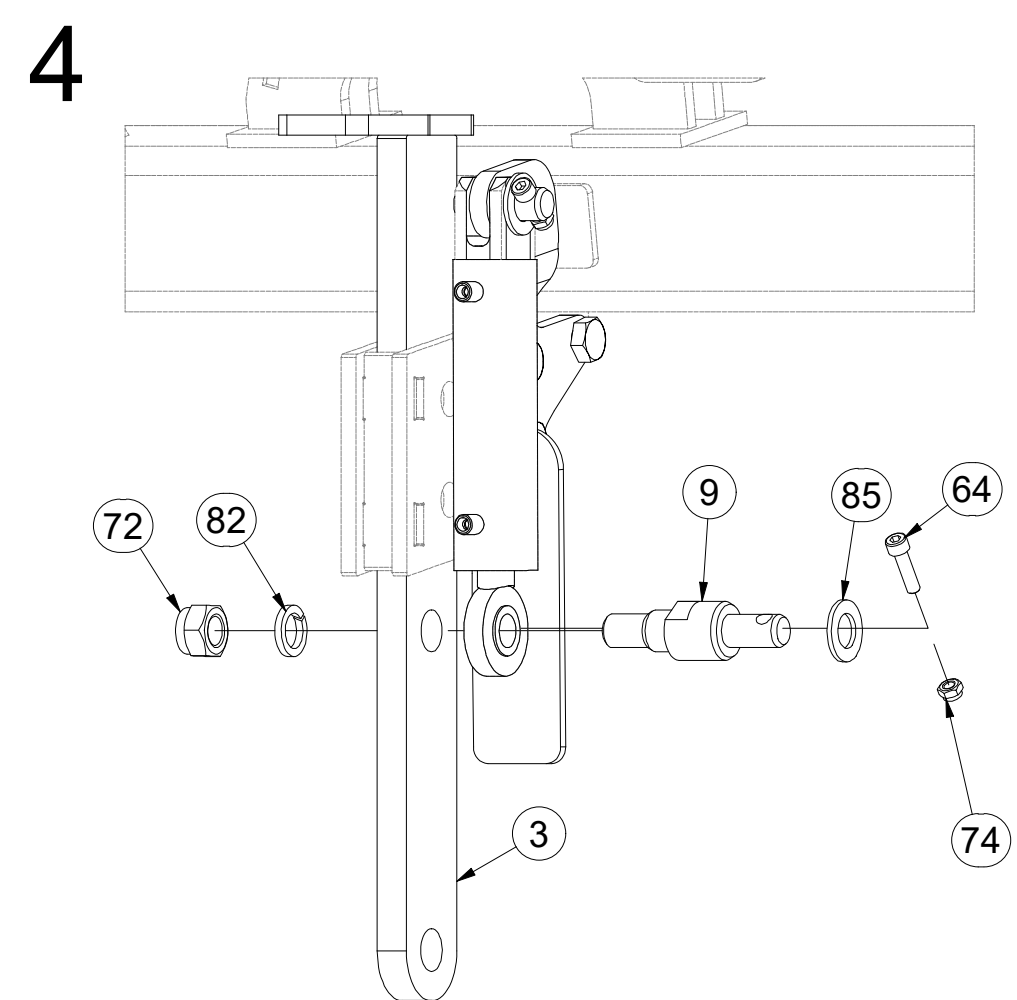
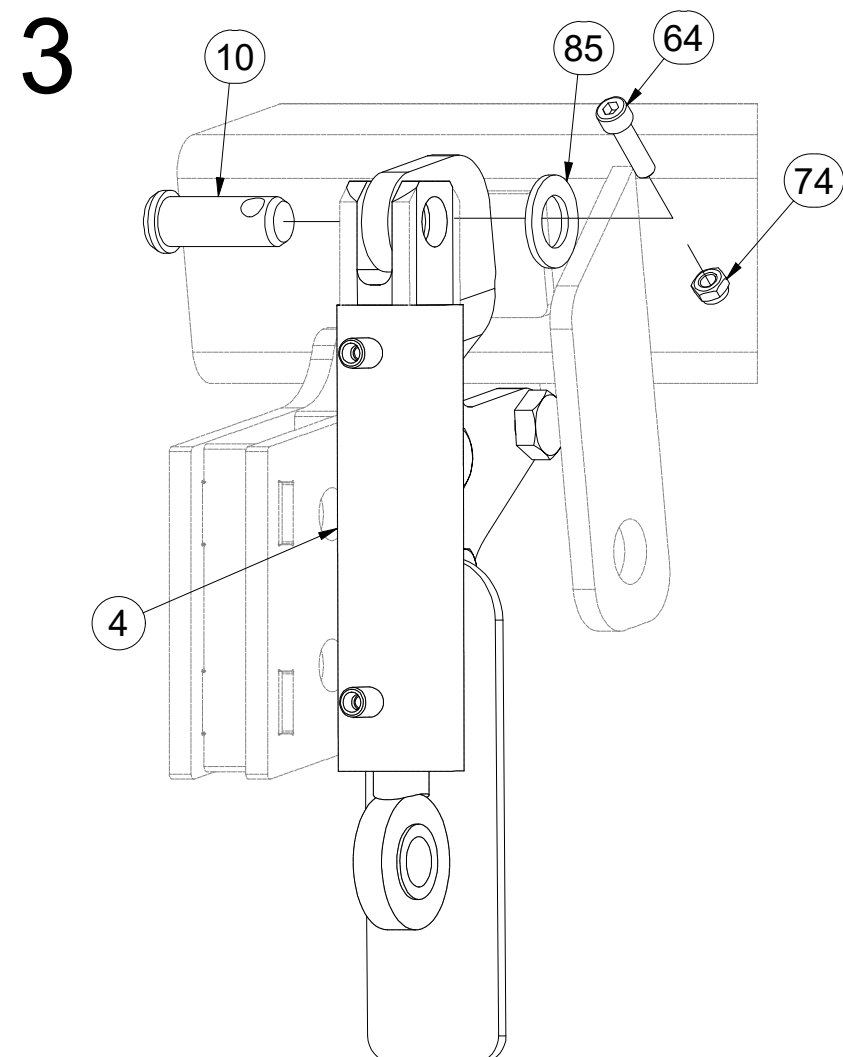
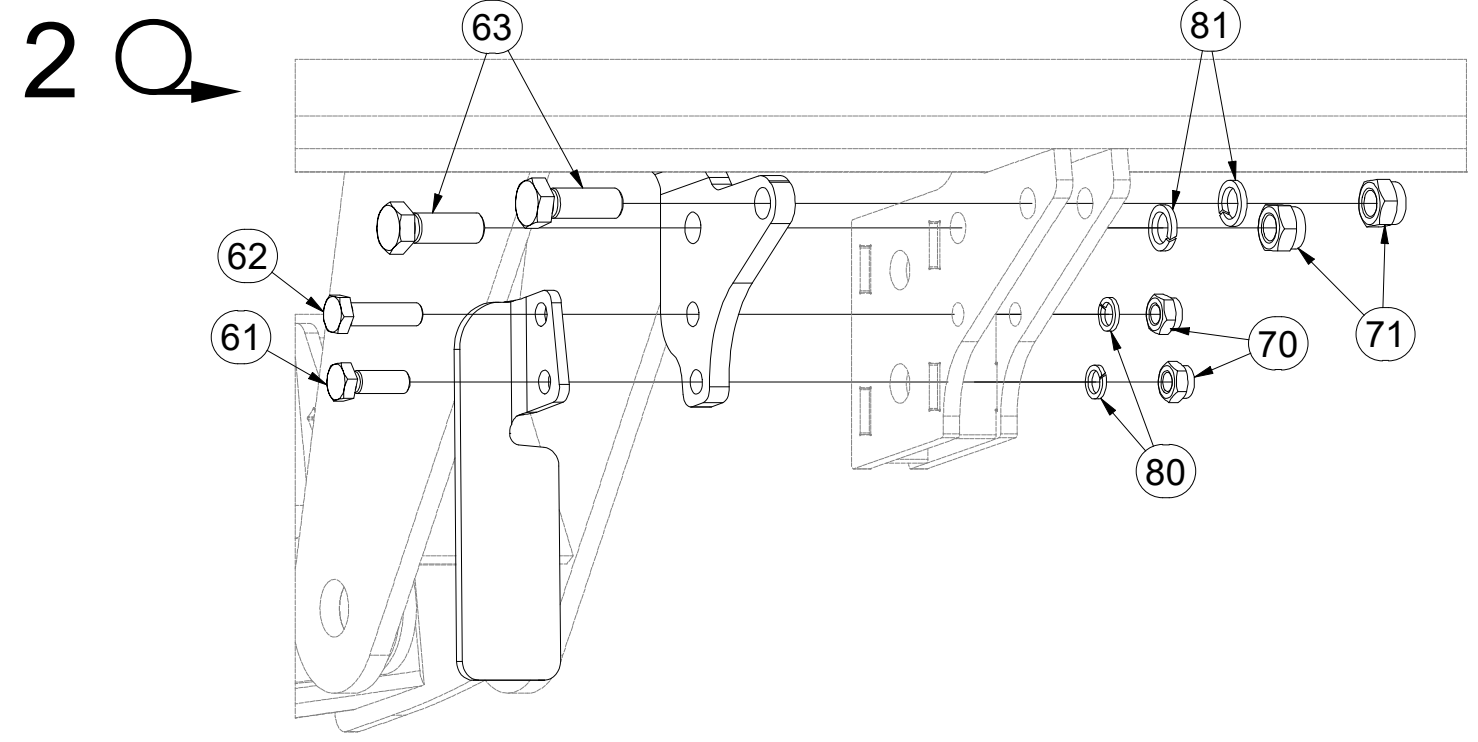
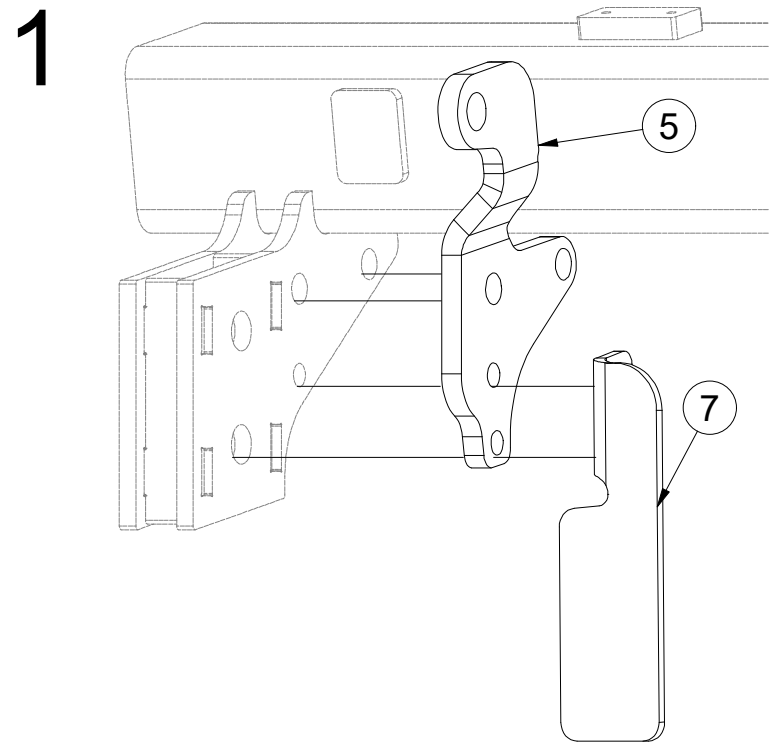
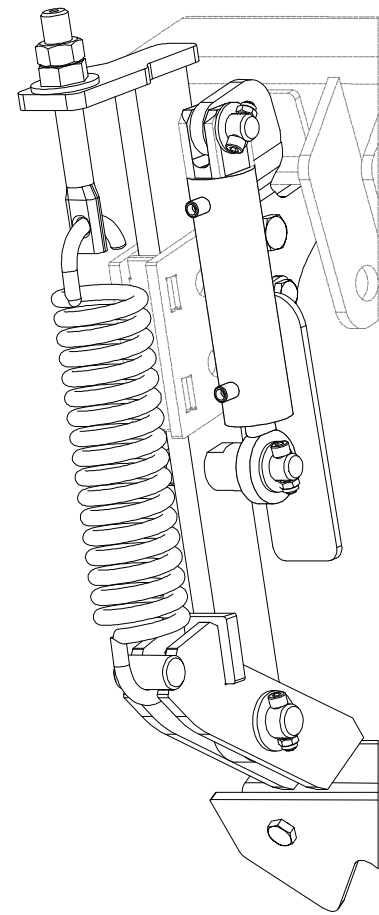

Pos.	Part Number	Pcs.
3	3008688	4
4	VZ00012974	4
5	4010386	2
7	4010388	2
9	VZ00023103	4
10	4015710	4
61	m04343	4
62	m06077	4
63	m02254	8
64	m09870	8
70	m04301	8
71	m03683	8
72	m05648	4
74	m04503	16
80	m03988	8
81	m02157	8
82	m01229	4
85	m03768	8

Ⓒ SADA PŘEDNÍCH SMYKŮ

Ⓓ SATZ VORDERE ACKERSCHLEPPEN

Ⓕ KIT DE NIVELEURS AVANT

Ⓖ SET OF FRONT LEVELLING BARS

Ⓔ КОМПЛЕКТ ПЕРЕДНИХ БОРОН

Ⓟ ZESTAW PRZEDNICH WŁÓK

Farmet

3006409

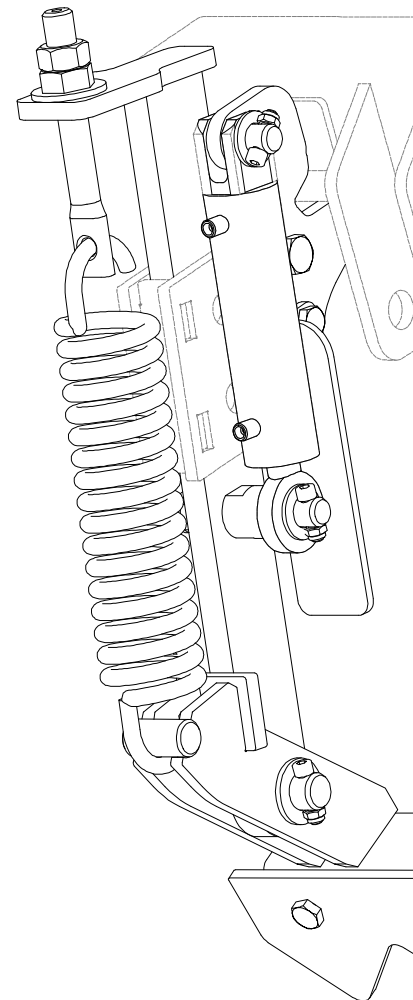

5

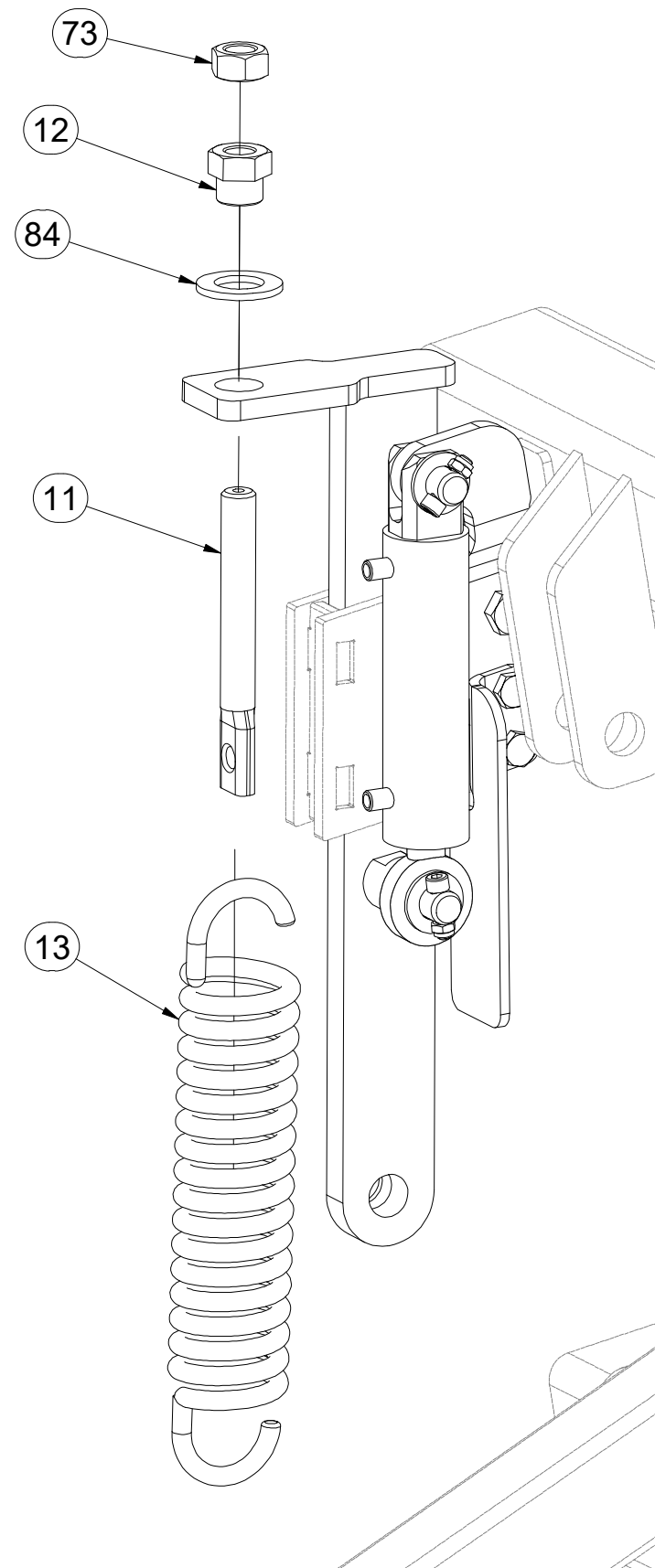

6

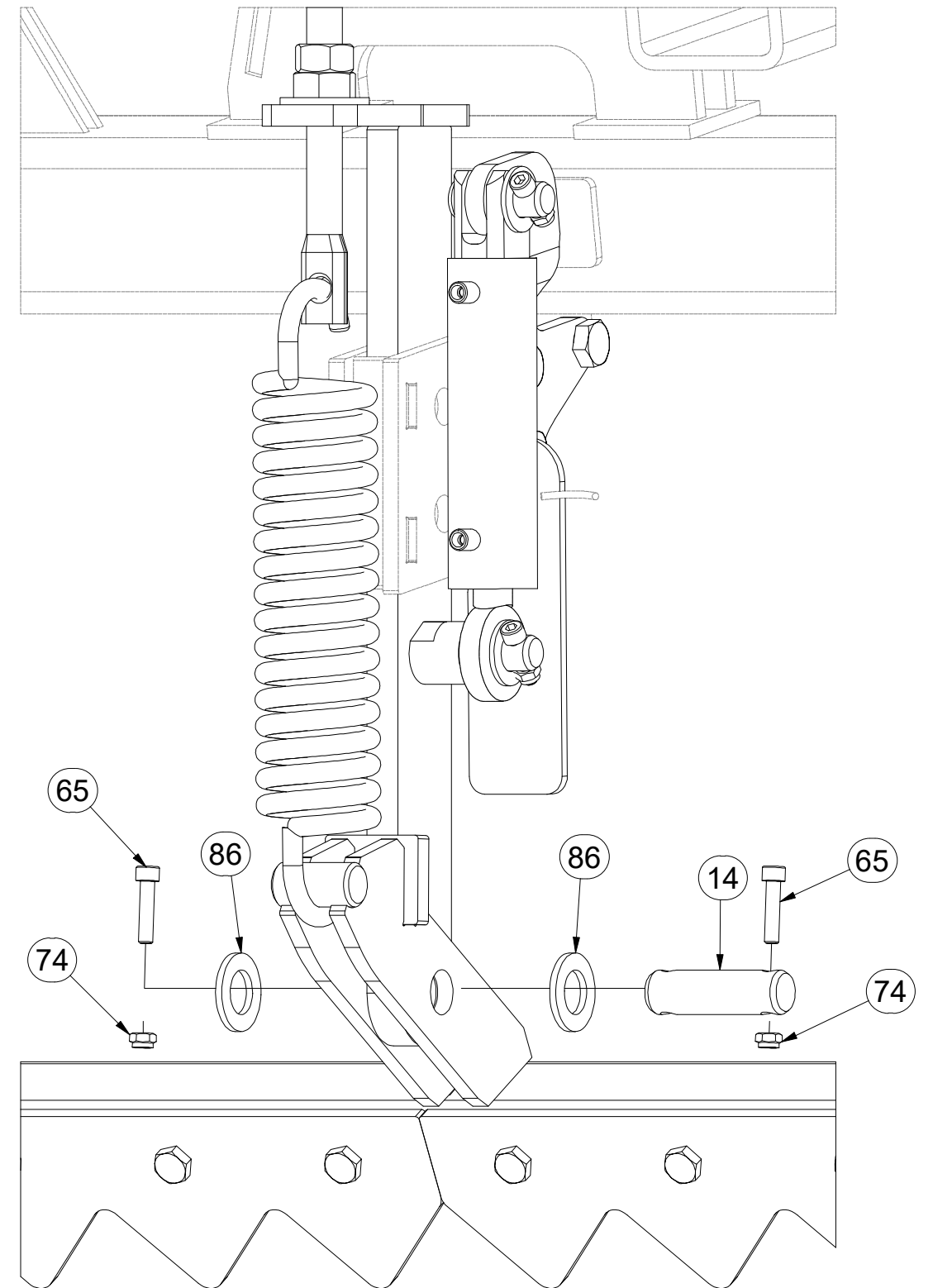

Pos.	Part Number	Pcs.
11	4003401	4
12	4000189	4
13	m02597	4
14	4010390	4
65	m09464	8
73	m01307	4
74	m04503	16
84	m01225	4
86	m14028	8

ⒸZ SADA PŘEDNÍCH SMYKŮ

Ⓓ SATZ VORDERE ACKERSCHLEPPEN

Ⓕ KIT DE NIVELEURS AVANT

ⒼB SET OF FRONT LEVELLING BARS

ⒺU КОМПЛЕКТ ПЕРЕДНИХ БОРОН

ⒽL ZESTAW PRZEDNICH WŁÓK



3006409

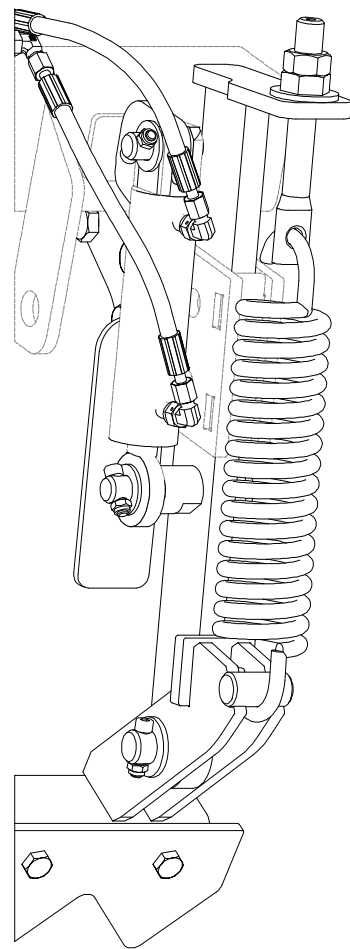

1

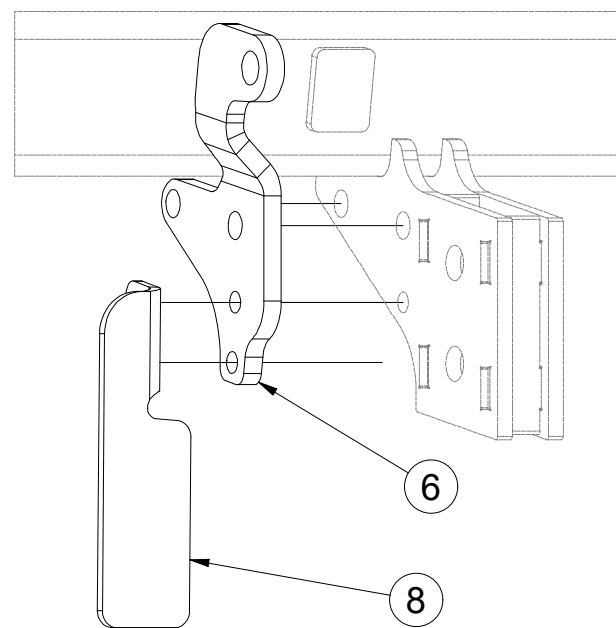

2 Q

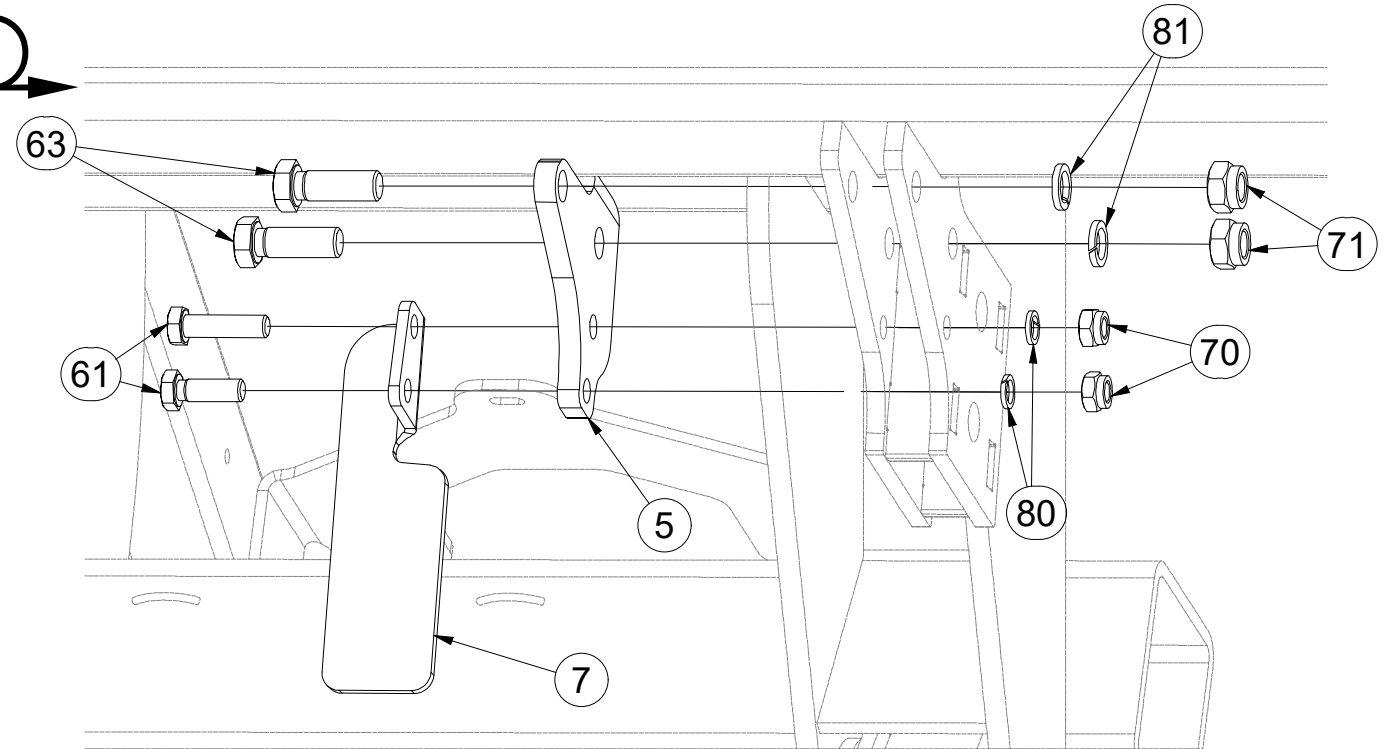

3

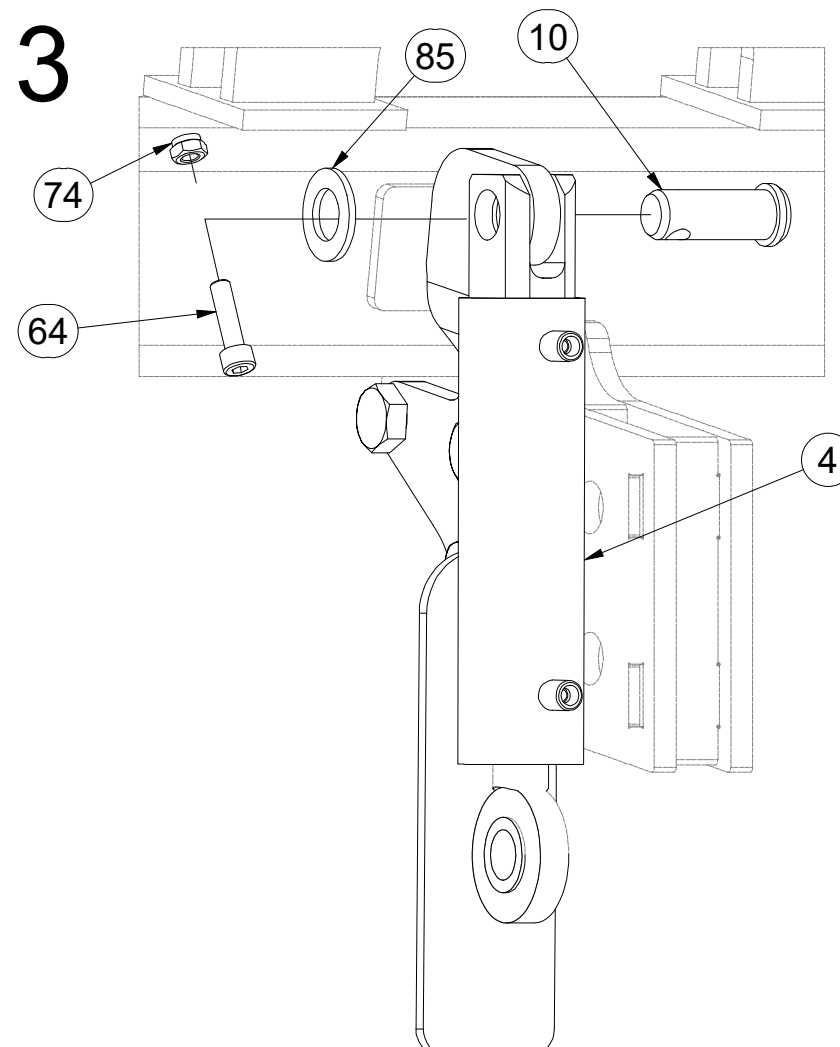

4

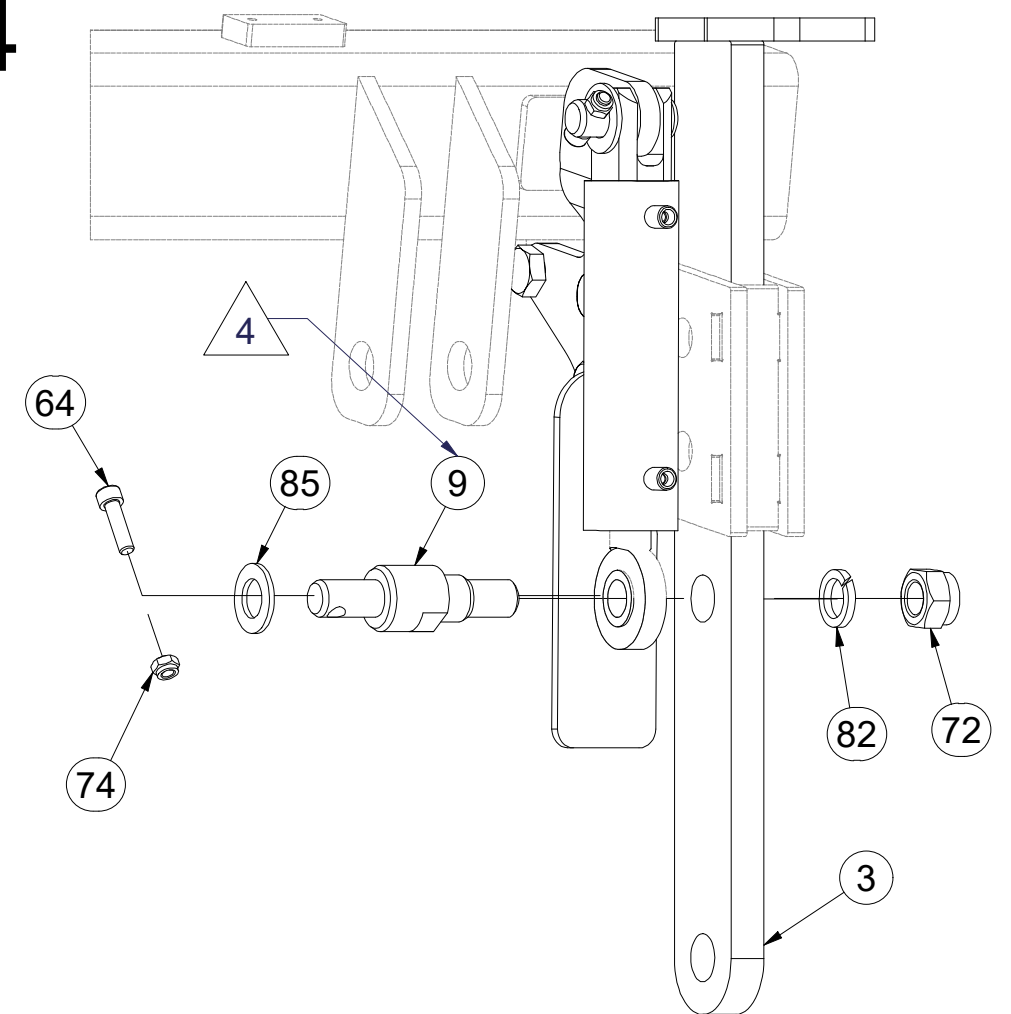

Pos.	Part Number	Pcs.
3	3008688	4
4	VZ00012974	4
5	4010386	2
6	4010387	2
7	4010388	2
8	4010389	2
9	VZ00023103	4
10	4015710	4
61	m04343	4
63	m02254	8
64	m09870	8
70	m04301	8
71	m03683	8
72	m05648	4
74	m04503	16
80	m03988	8
81	m02157	8
82	m01229	4
85	m03768	8

Ⓒ SADA PŘEDNÍCH SMYKŮ

Ⓓ SATZ VORDERE ACKERSCHLEPPEN

Ⓕ KIT DE NIVELEURS AVANT

Ⓖ SET OF FRONT LEVELLING BARS

Ⓡ КОМПЛЕКТ ПЕРЕДНИХ БОРОН

Ⓟ ZESTAW PRZEDNICH WŁÓK

Farmet

3006409

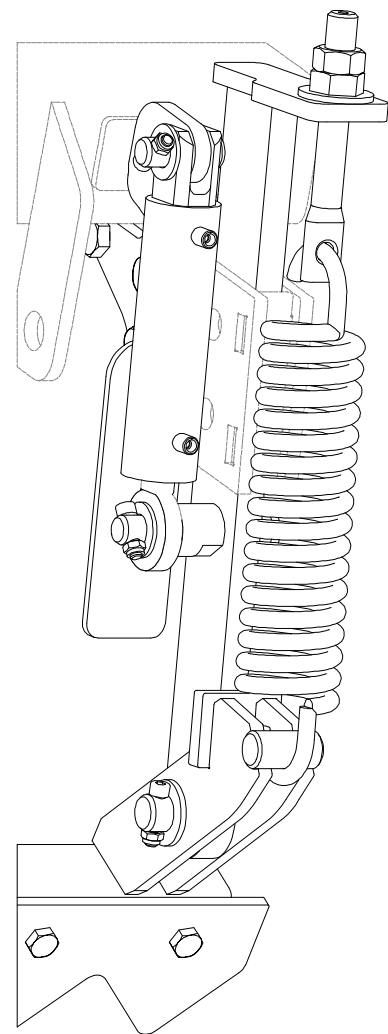

5

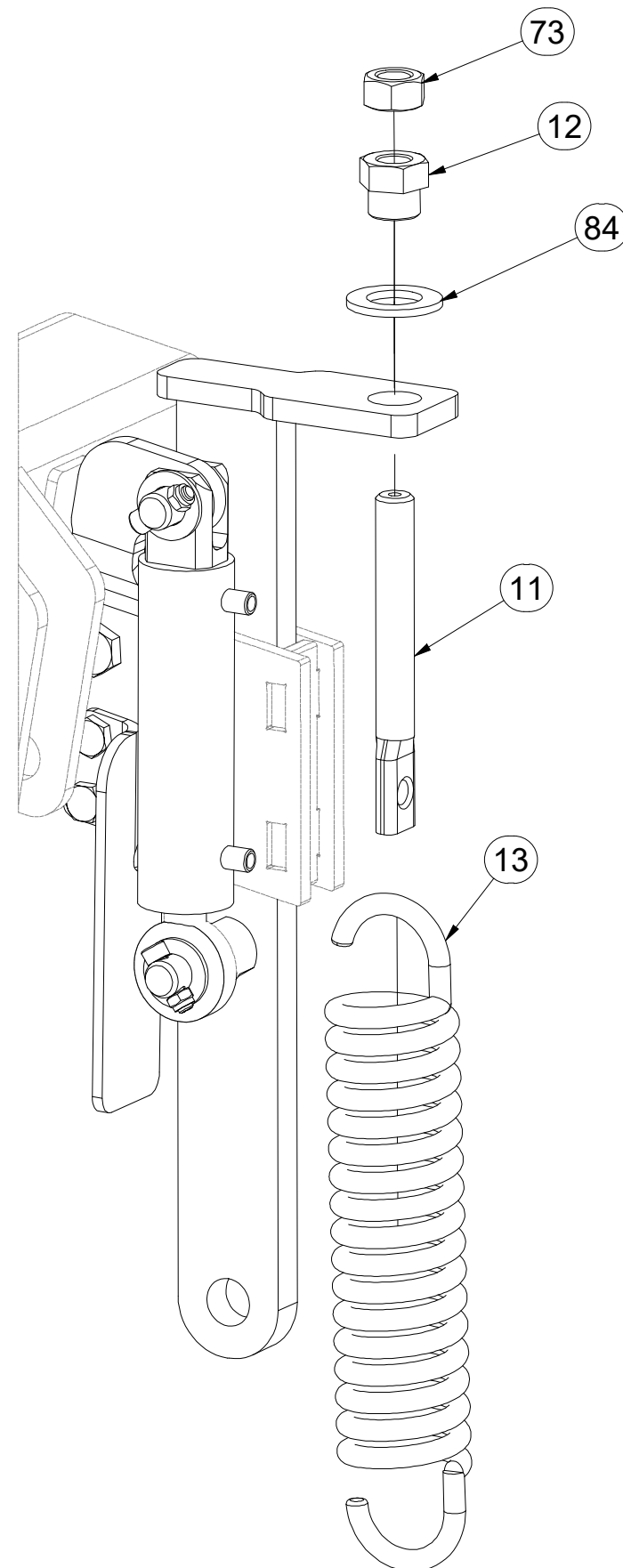

6

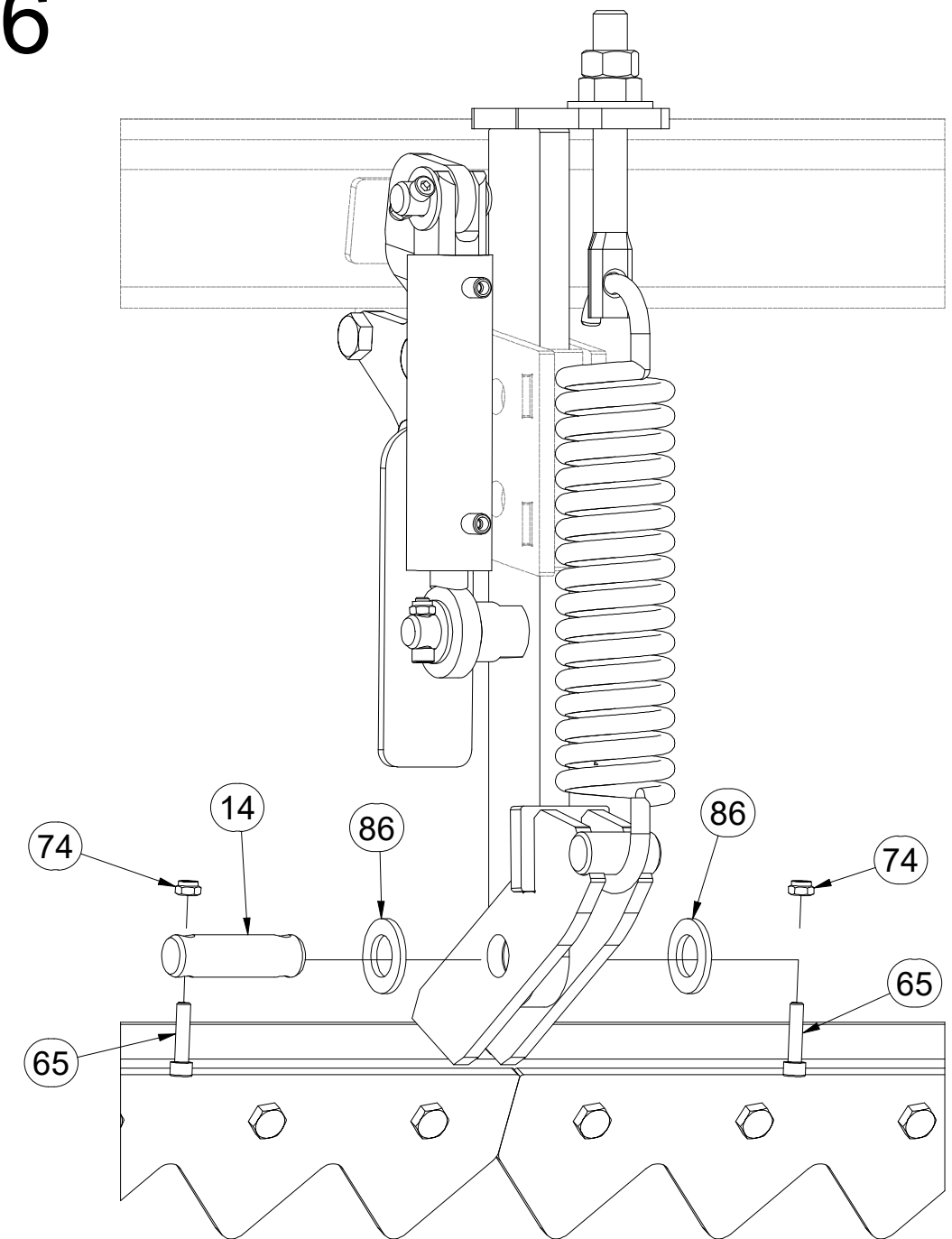

Pos.	Part Number	Pcs.
11	4003401	4
12	4000189	4
13	m02597	4
14	4010390	4
65	m09464	8
73	m01307	4
74	m04503	16
84	m01225	4
86	m14028	8

Ⓒ SADA PŘEDNÍCH SMYKŮ

Ⓓ SATZ VORDERE ACKERSCHLEPPEN

Ⓕ KIT DE NIVELEURS AVANT

Ⓖ SET OF FRONT LEVELLING BARS

Ⓡ КОМПЛЕКТ ПЕРЕДНИХ БОРОН

Ⓟ ZESTAW PRZEDNICH WŁÓK



3006409

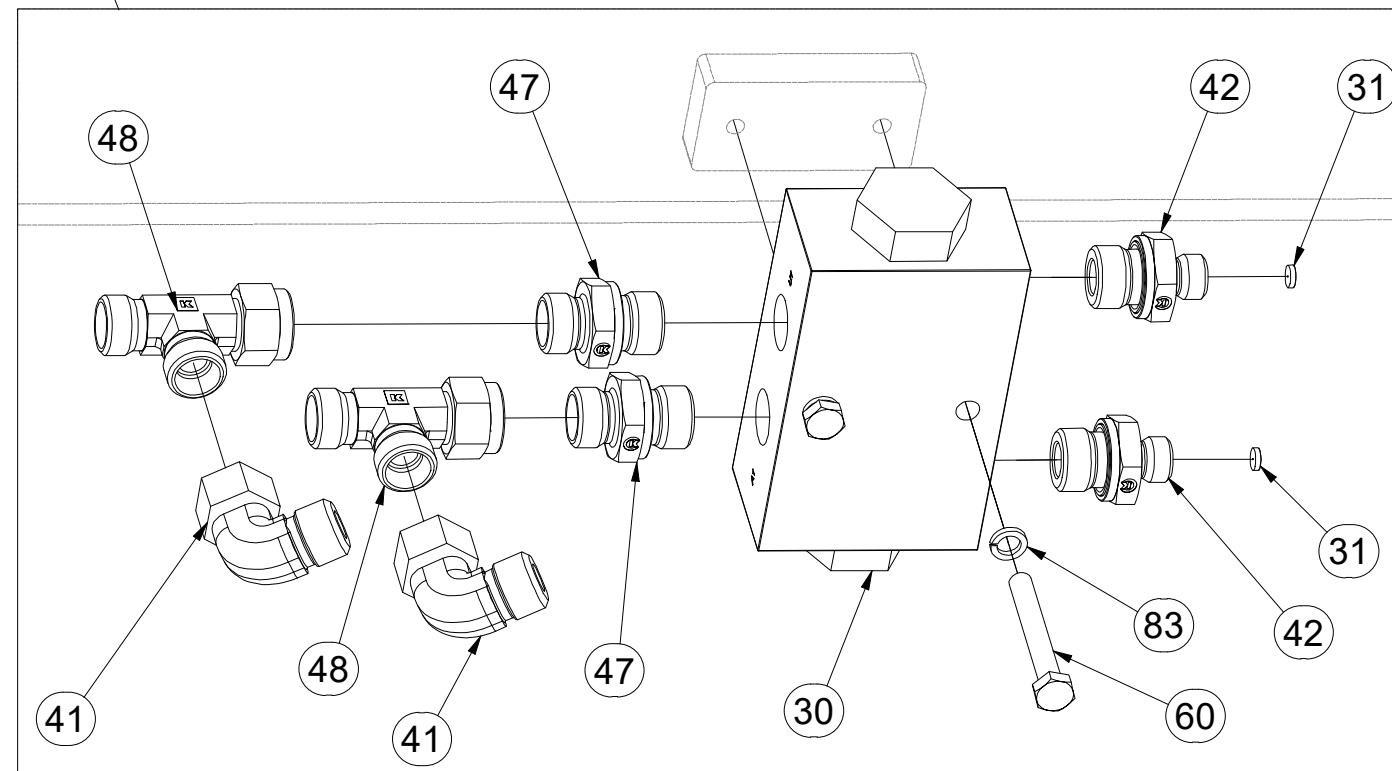
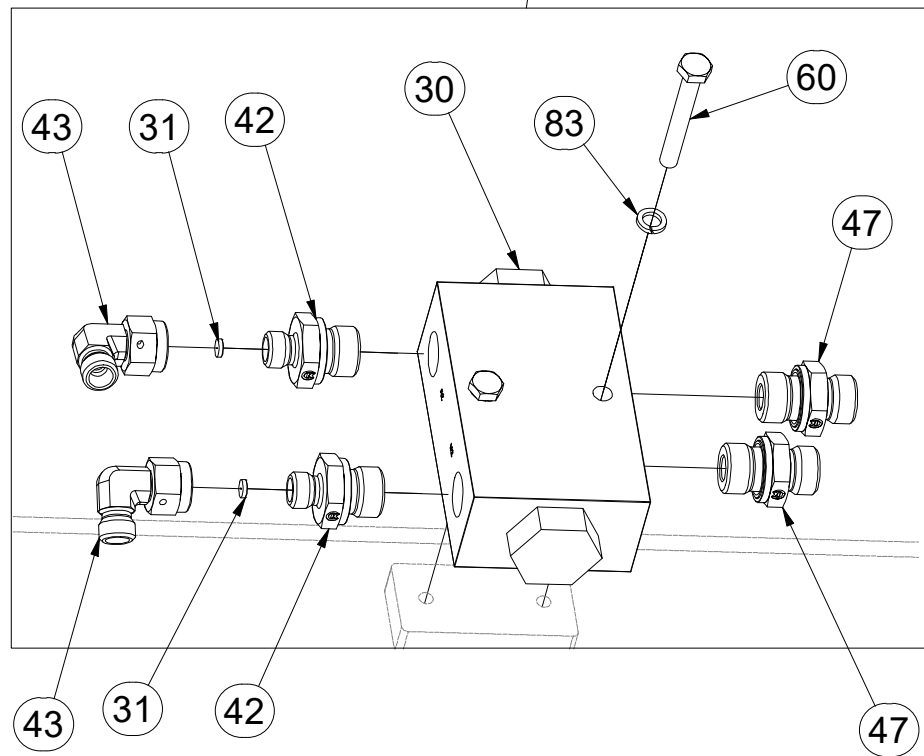
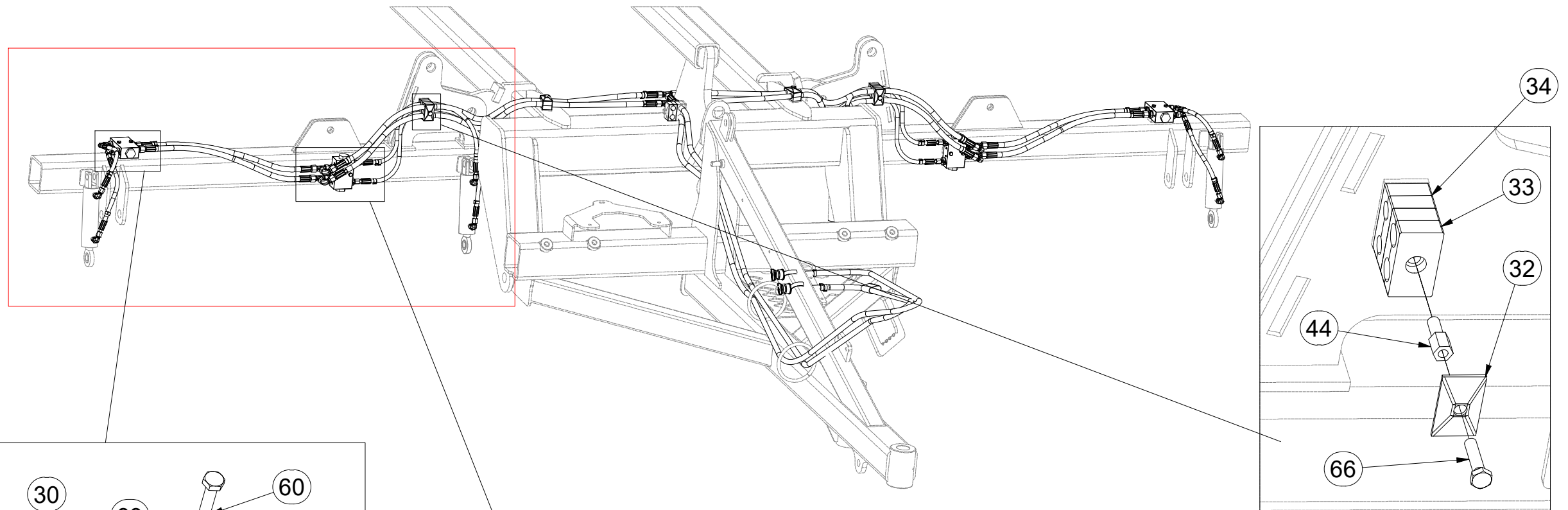

Pos.	Part Number	Pcs.	Pos.	Part Number	Pcs.
30	m09911	4	43	m12953	4
31	m12986	8	44	m04627	3
32	m04173	4	47	m06528	8
33	m04171	5	48	m07568	4
34	m13868	2	60	m05561	8
41	m06803	4	66	m01096	4
42	m12951	8	83	m01200	8

ⒸZ SADA PŘEDNÍCH SMYKŮ

Ⓓ SATZ VORDERE ACKERSCHLEPPEN

Ⓕ KIT DE NIVELEURS AVANT

ⒼB SET OF FRONT LEVELLING BARS

ⒺU КОМПЛЕКТ ПЕРЕДНИХ БОРОН

ⒽL ZESTAW PRZEDNICH WŁÓK



3006409

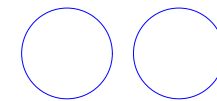
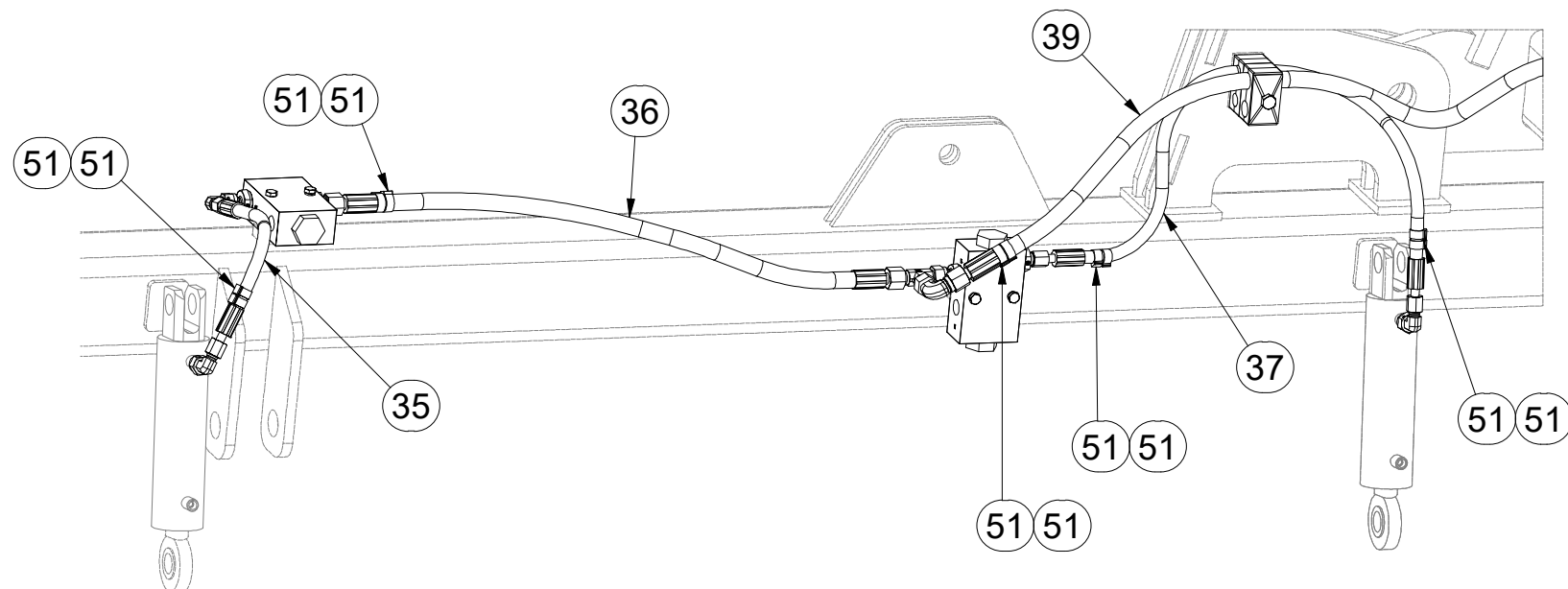
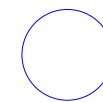
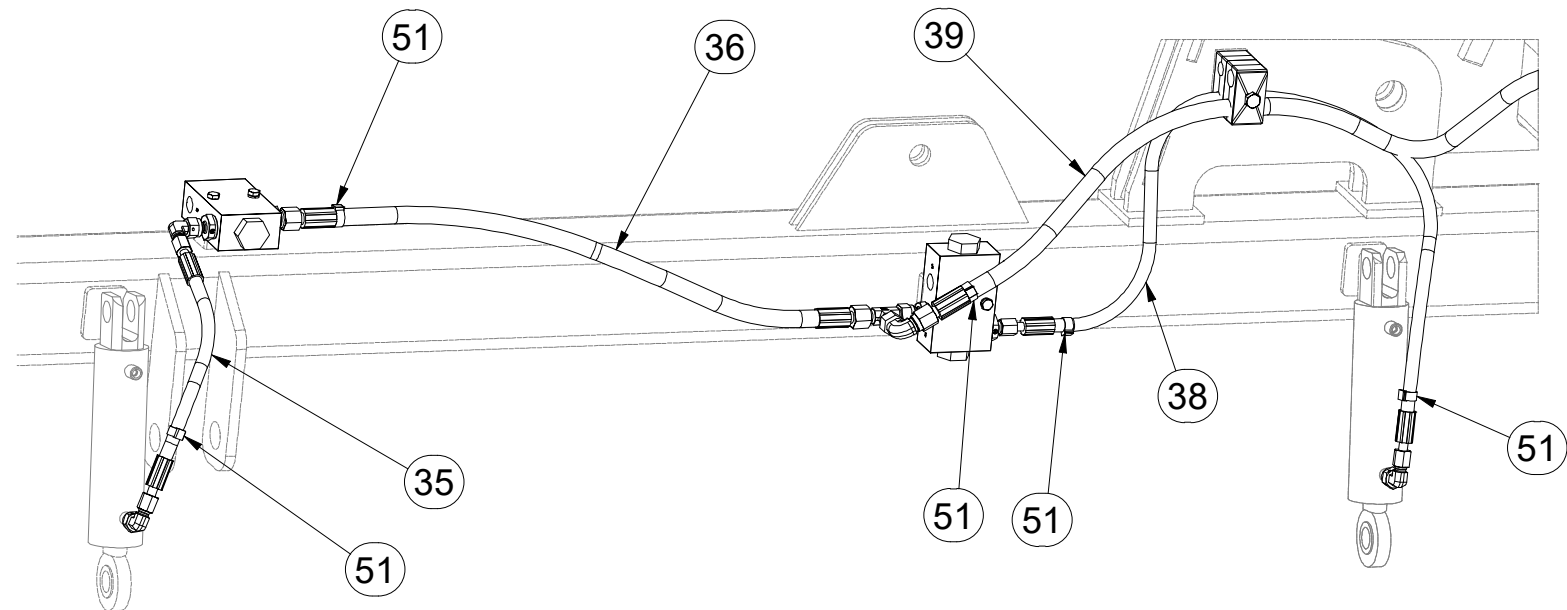
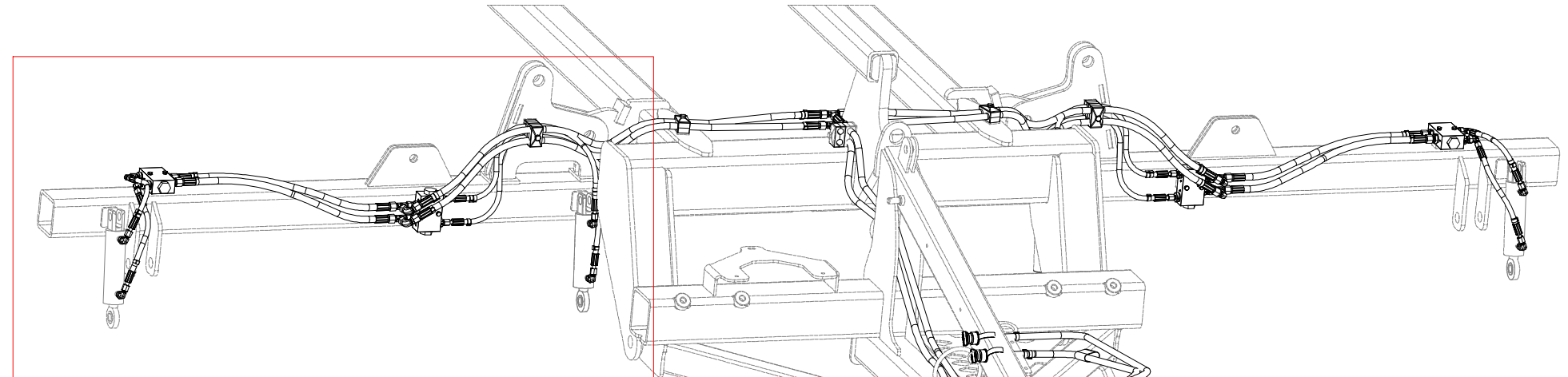

Pos.	Part Number	Pcs.
35	m13869	4
36	m16666	4
37	m13872	2
38	m13871	2
39	m07504	4
51	m11253	42

ⒸZ SADA PŘEDNÍCH SMYKŮ

Ⓓ SATZ VORDERE ACKERSCHLEPPEN

Ⓕ KIT DE NIVELEURS AVANT

ⒼB SET OF FRONT LEVELLING BARS

ⒺU КОМПЛЕКТ ПЕРЕДНИХ БОРОН

ⒼL ZESTAW PRZEDNICH WŁÓK



3006409

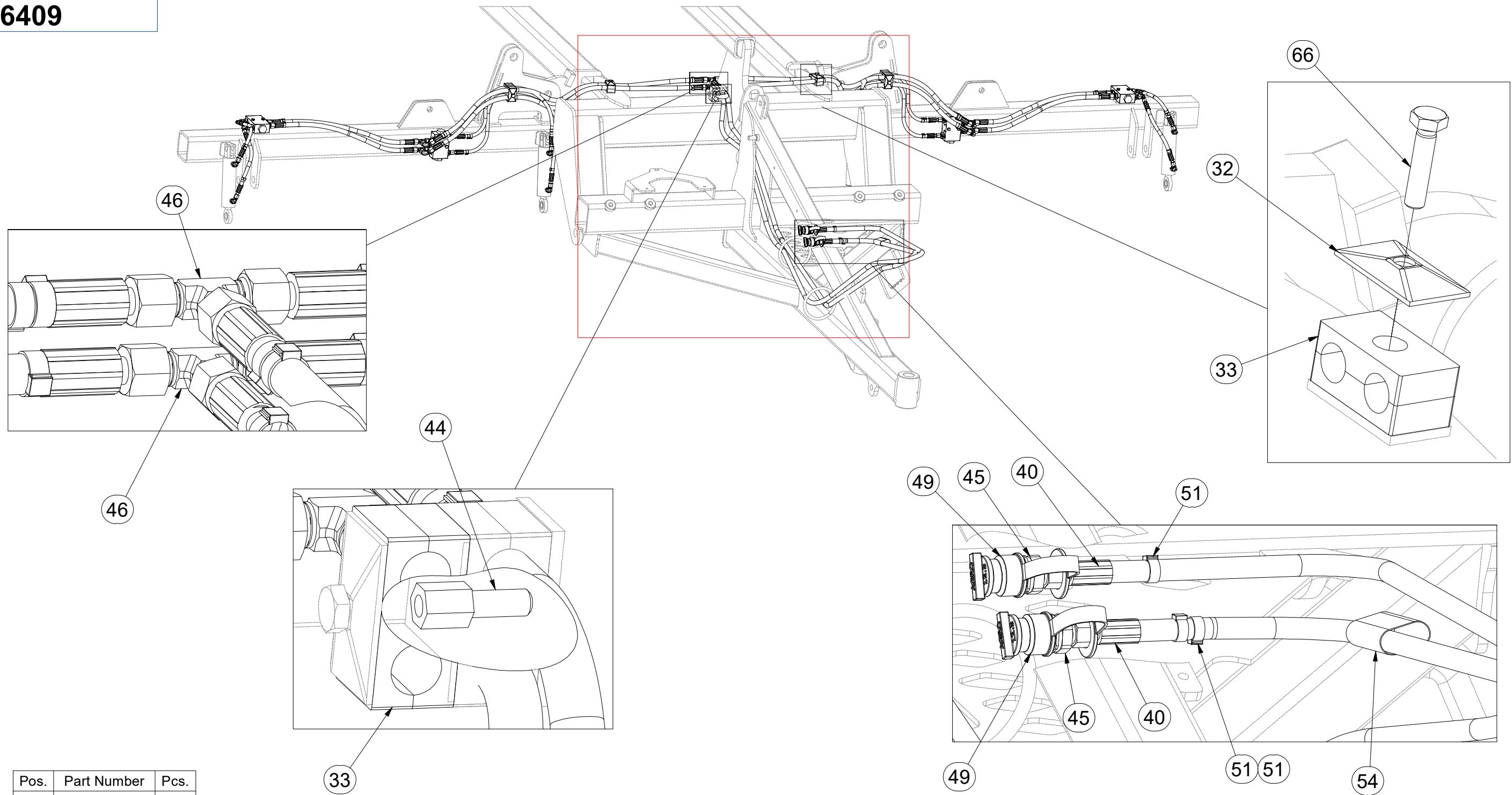

Pos.	Part Number	Pcs.
32	m04173	4
33	m04171	5
40	m09036	2
44	m04627	3
45	m03849	2
46	m03889	2
49	m03743	2
51	m11253	42
54	m11183	1
66	m01096	4

ⒸZ SADA PŘEDNÍCH SMYKŮ

Ⓓ SATZ VORDERE ACKERSCHLEPPEN

Ⓕ KIT DE NIVELEURS AVANT

ⒸB SET OF FRONT LEVELLING BARS

Ⓔ КОМПЛЕКТ ПЕРЕДНИХ БОРОН

ⒶL ZESTAW PRZEDNICH WŁÓK

Farmet

3006409

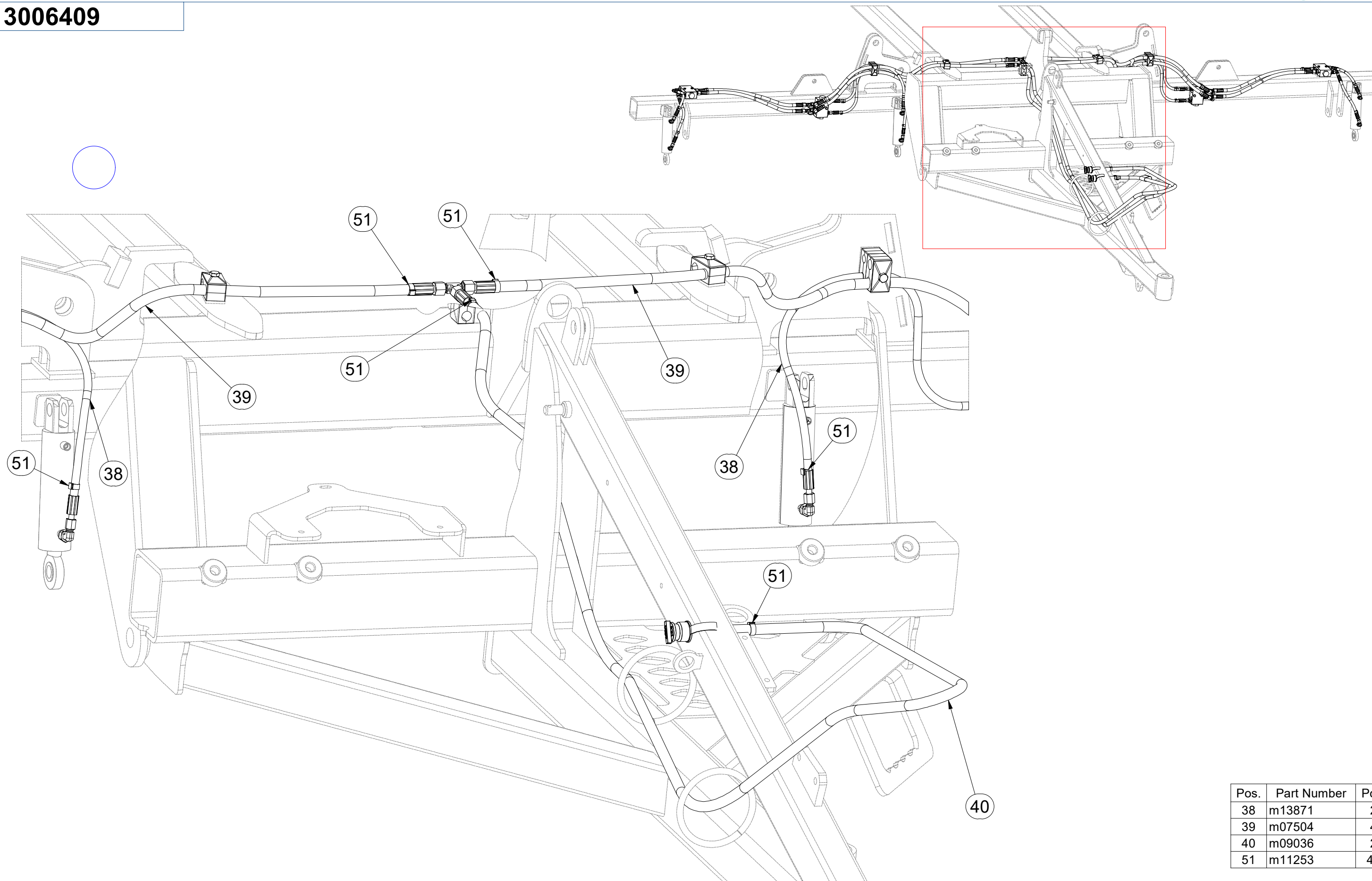

Pos.	Part Number	Pcs.
38	m13871	2
39	m07504	4
40	m09036	2
51	m11253	42

ⒸZ SADA PŘEDNÍCH SMYKŮ

Ⓓ SATZ VORDERE ACKERSCHLEPPEN

Ⓕ KIT DE NIVELEURS AVANT

ⒼB SET OF FRONT LEVELLING BARS

ⒺR КОМПЛЕКТ ПЕРЕДНИХ БОРОН

ⒶL ZESTAW PRZEDNICH WŁÓK



3006409

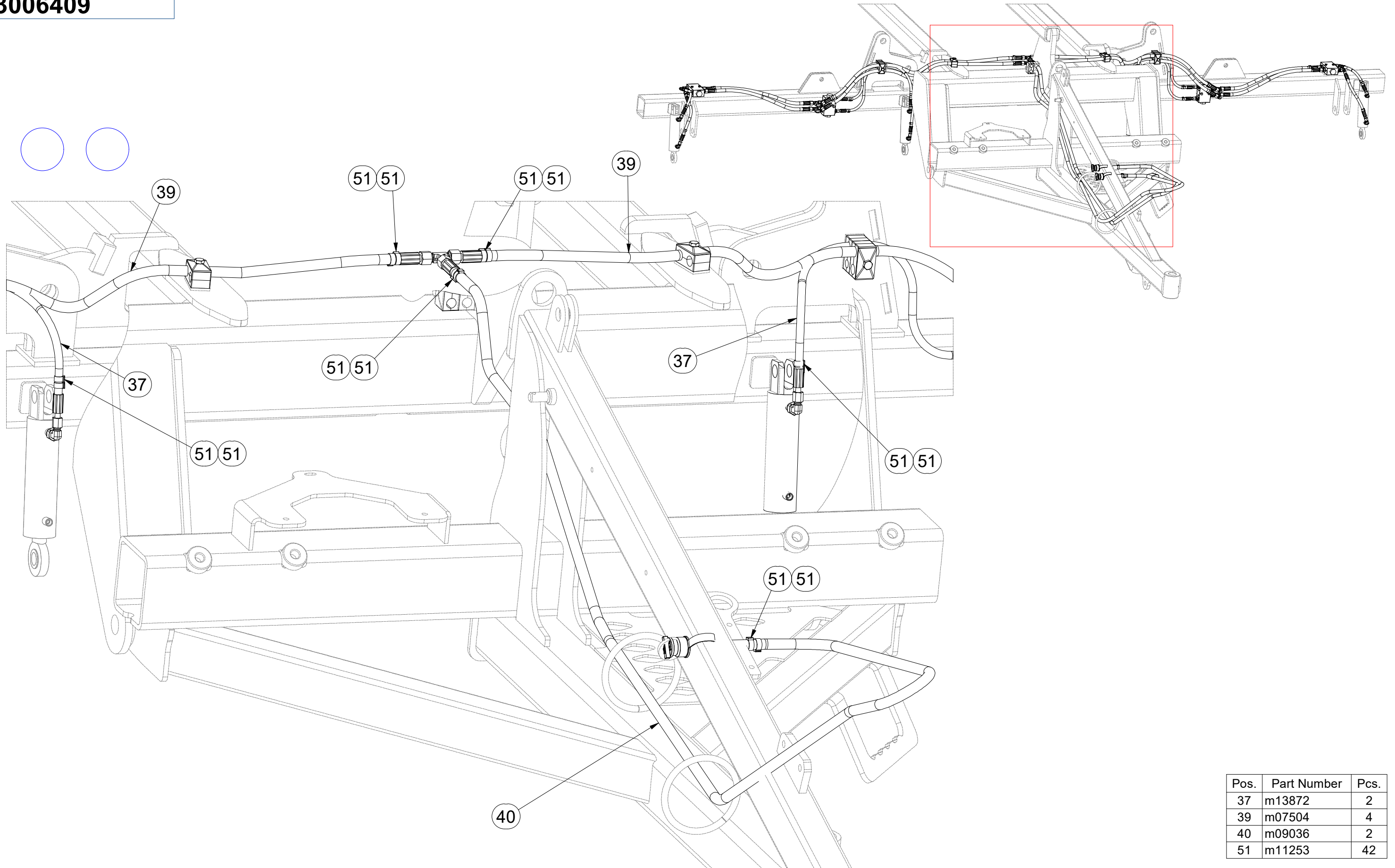

Pos.	Part Number	Pcs.
37	m13872	2
39	m07504	4
40	m09036	2
51	m11253	42

ⒸZ SADA PŘEDNÍCH SMYKŮ

Ⓓ SATZ VORDERE ACKERSCHLEPPEN

Ⓕ KIT DE NIVELEURS AVANT

ⒼB SET OF FRONT LEVELLING BARS

ⒺU КОМПЛЕКТ ПЕРЕДНИХ БОРОН

ⒺL ZESTAW PRZEDNICH WŁÓK



3006409

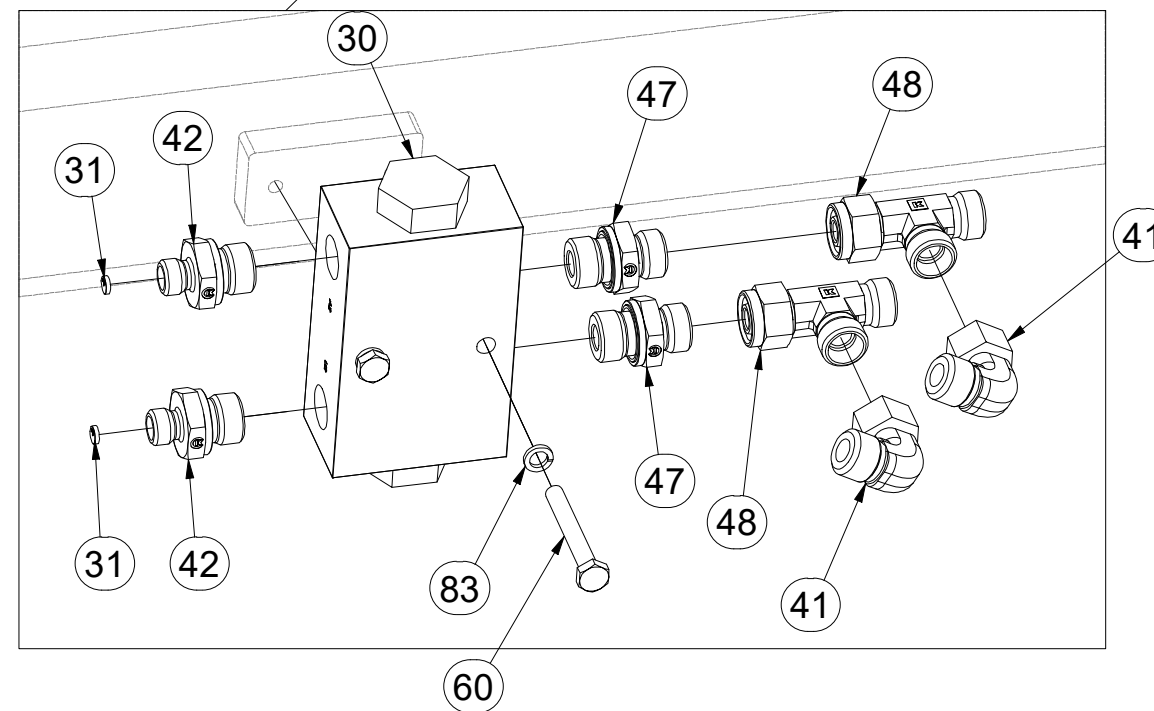
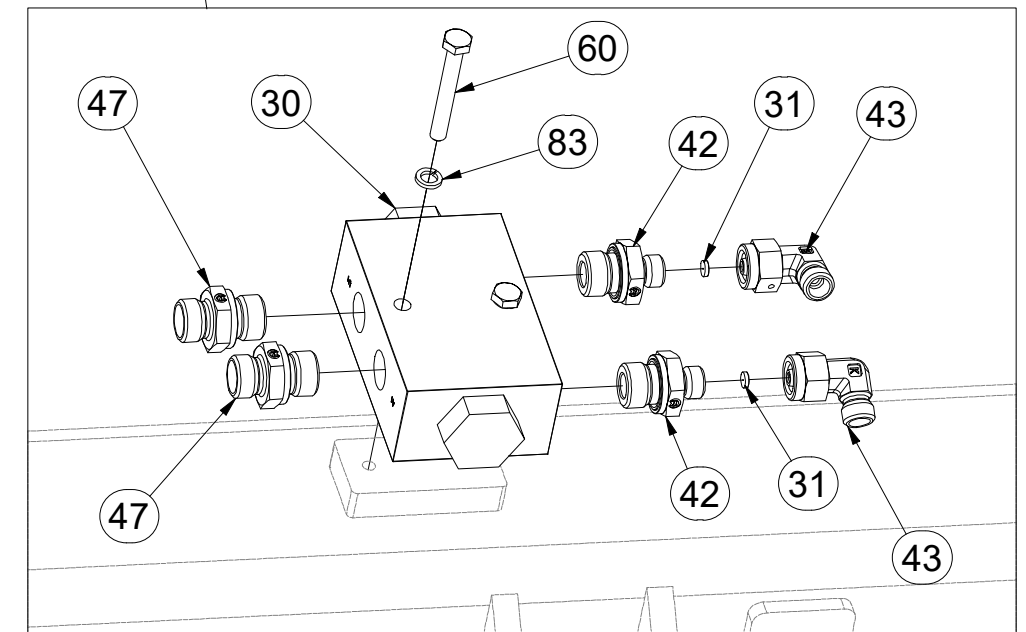
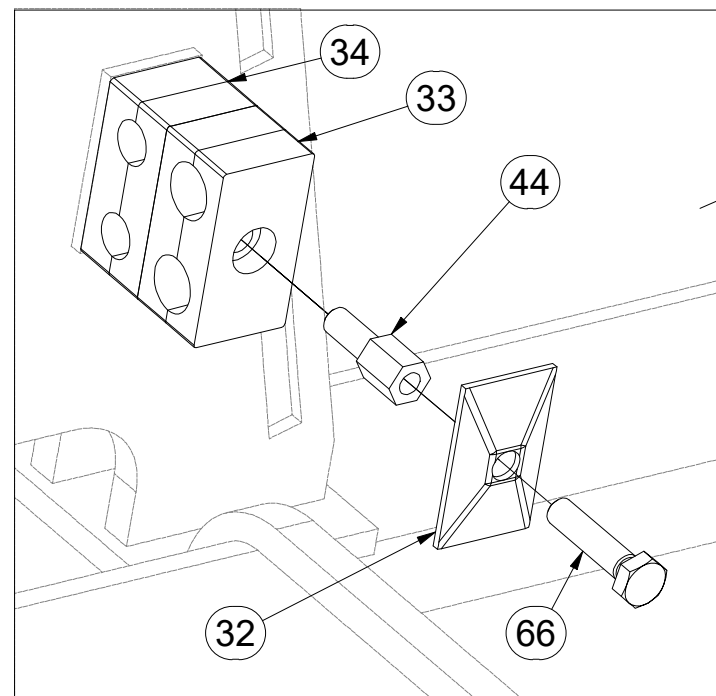
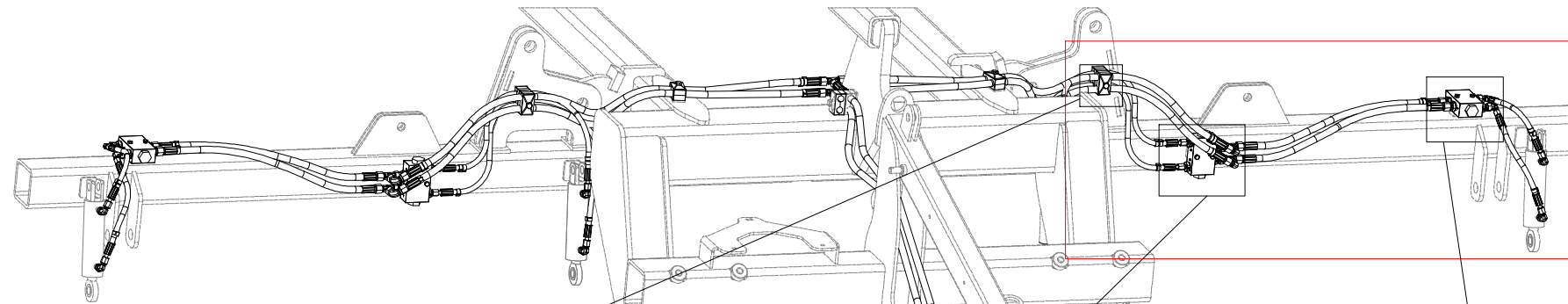

Pos.	Part Number	Pcs.
30	m09911	4
31	m12986	8
32	m04173	4
33	m04171	5
34	m13868	2
41	m06803	4
42	m12951	8
43	m12953	4
44	m04627	3
47	m06528	8
48	m07568	4
60	m05561	8
66	m01096	4
83	m01200	8

ⒸZ SADA PŘEDNÍCH SMYKŮ

Ⓓ SATZ VORDERE ACKERSCHLEPPEN

Ⓕ KIT DE NIVELEURS AVANT

ⒼB SET OF FRONT LEVELLING BARS

ⒺU КОМПЛЕКТ ПЕРЕДНИХ БОРОН

ⒼL ZESTAW PRZEDNICH WŁÓK



3006409

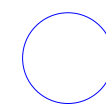
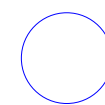
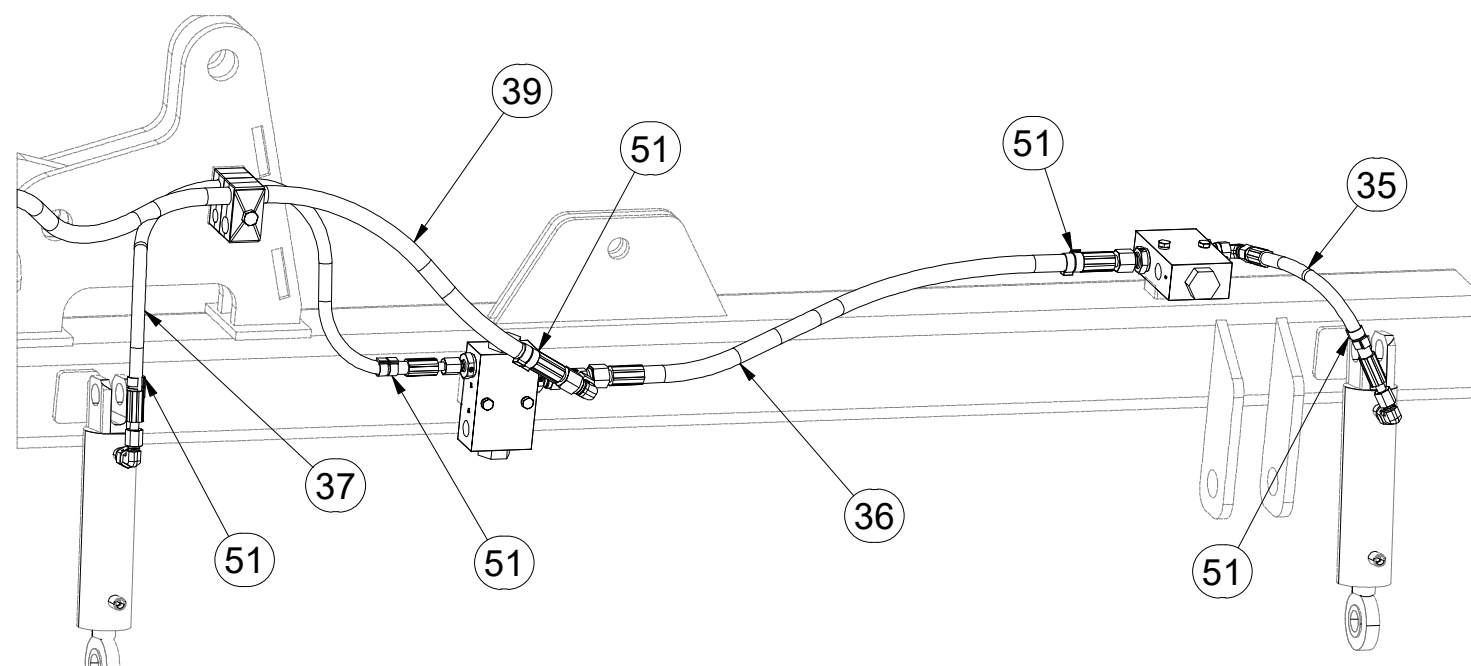
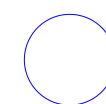
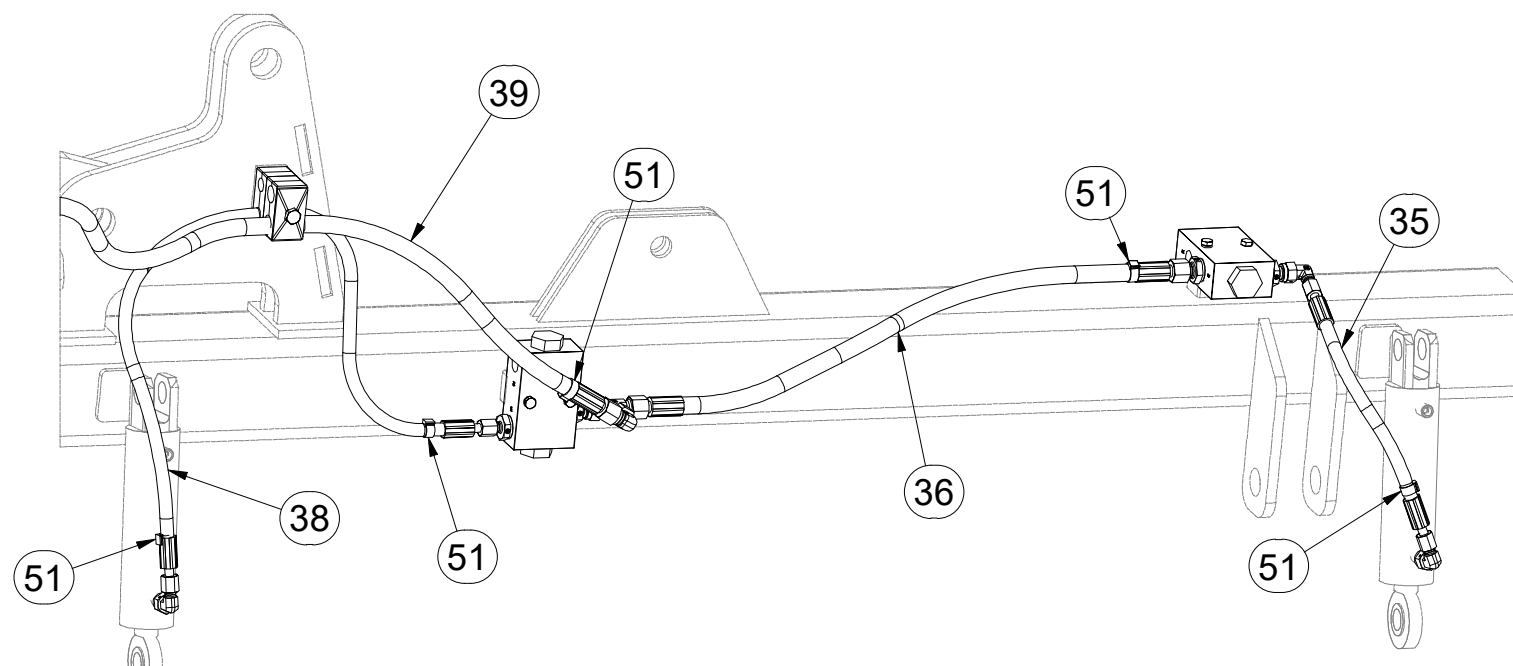
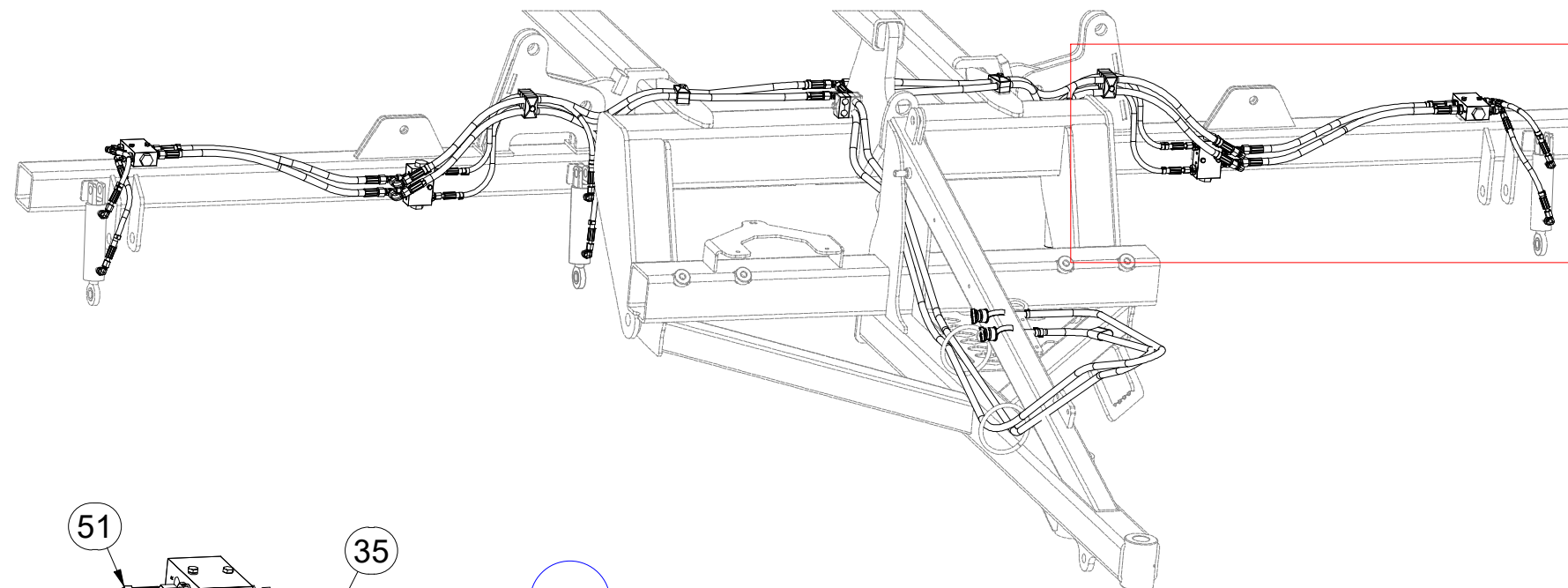

Pos.	Part Number	Pcs.
35	m13869	4
36	m16666	4
37	m13872	2
38	m13871	2
39	m07504	4
51	m11253	42

Ⓒ PŘEDNÍ SMYK

Ⓓ VORDERE ACKERSCHLEIFE

Ⓕ NIVELEUR AVANT

Ⓖ FRONT DRAG

Ⓡ ПЕРЕДНЯЯ БОРОНА

Ⓟ PRZEDNIA WŁÓKA

Farmet

3011481

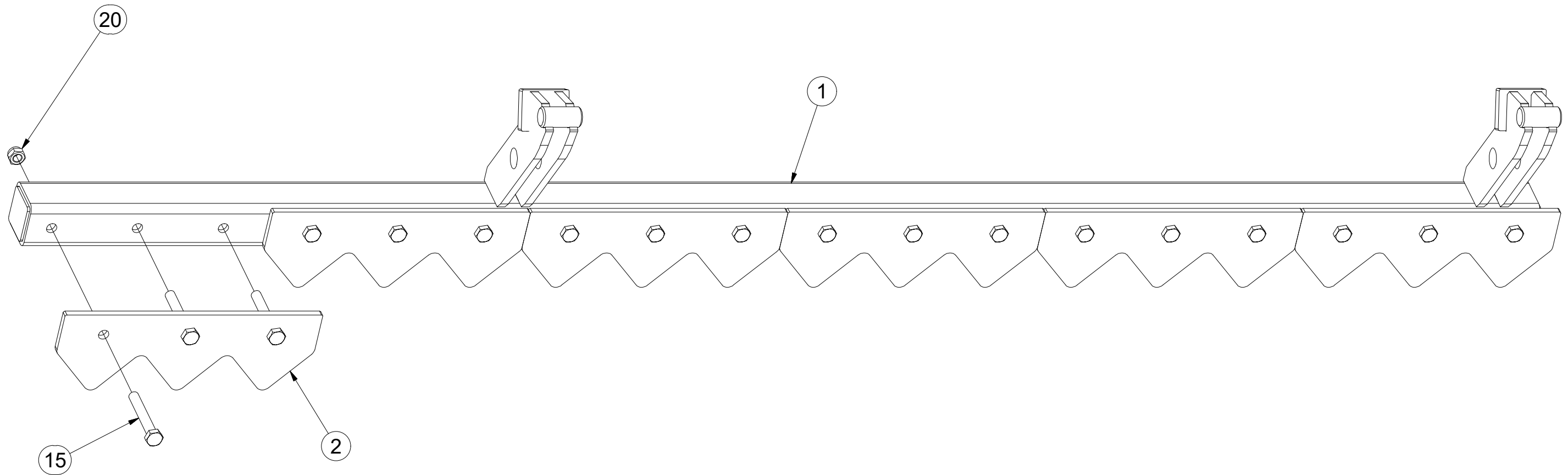

Pos.	Part Number	Pcs.
1	3011480	1
2	4021741	6
15	m09437	18
20	m04301	18

Ⓒ PŘEDNÍ SMYK

Ⓓ VORDERE ACKERSCHLEIFE

Ⓕ NIVELEUR AVANT

Ⓖ FRONT DRAG

Ⓡ ПЕРЕДНЯЯ БОРОНА

Ⓟ PRZEDNIA WŁÓKA

Farmet

3011483

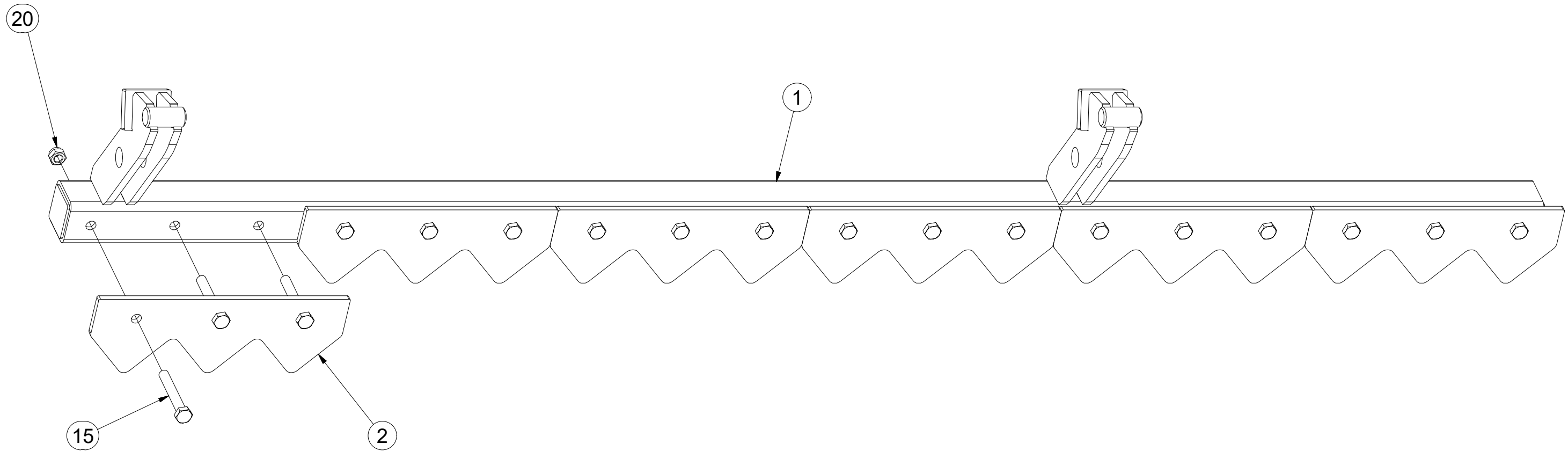

Pos.	Part Number	Pcs.
1	3011482	1
2	4021741	6
15	m09437	18
20	m04301	18

ⒸZ SADA PŘEDNÍCH VÁLCŮ

Ⓓ SATZ VORDERE WALZEN

Ⓕ KIT DE ROULEAUX AVANT

ⒼB SET OF FRONT ROLLERS

ⒶR КОМПЛЕКТ ПЕРЕДНИХ КАТКОВ

ⒶL ZESTAW PRZEDNICH WAŁÓW

Farmet

3011900

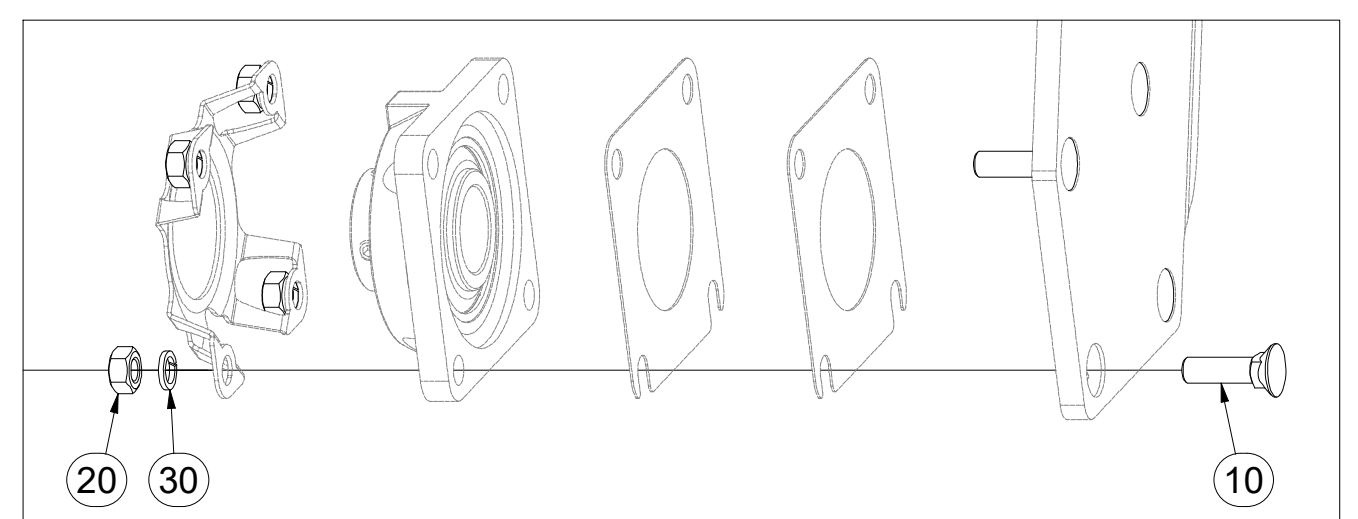
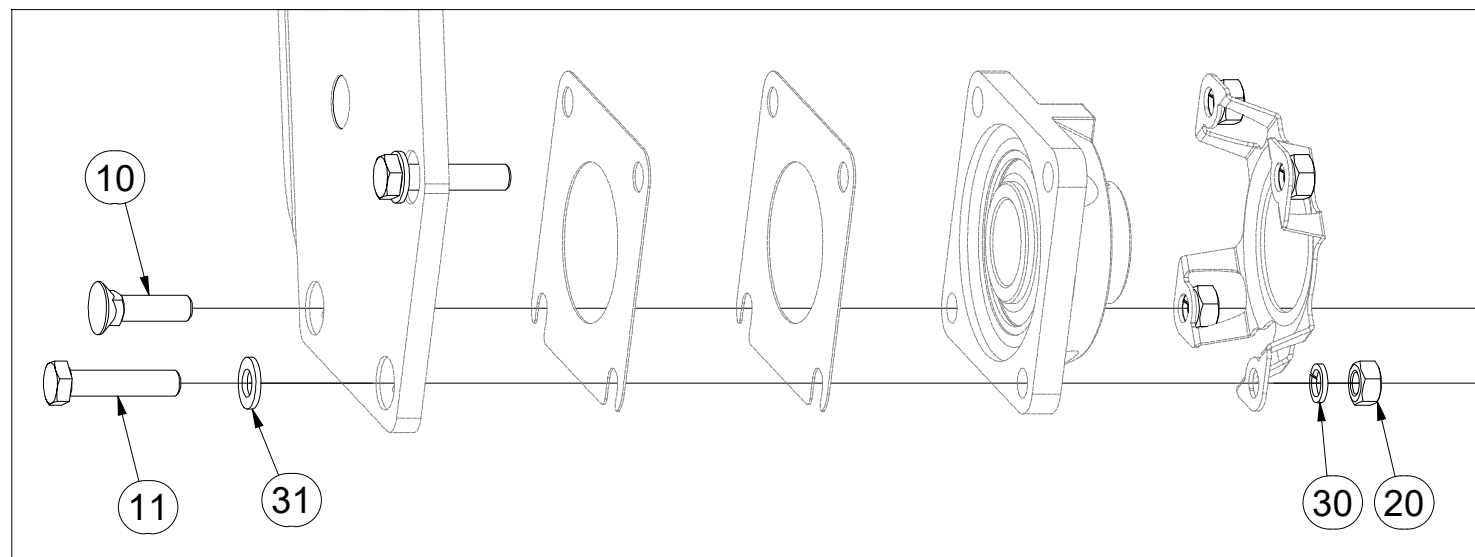
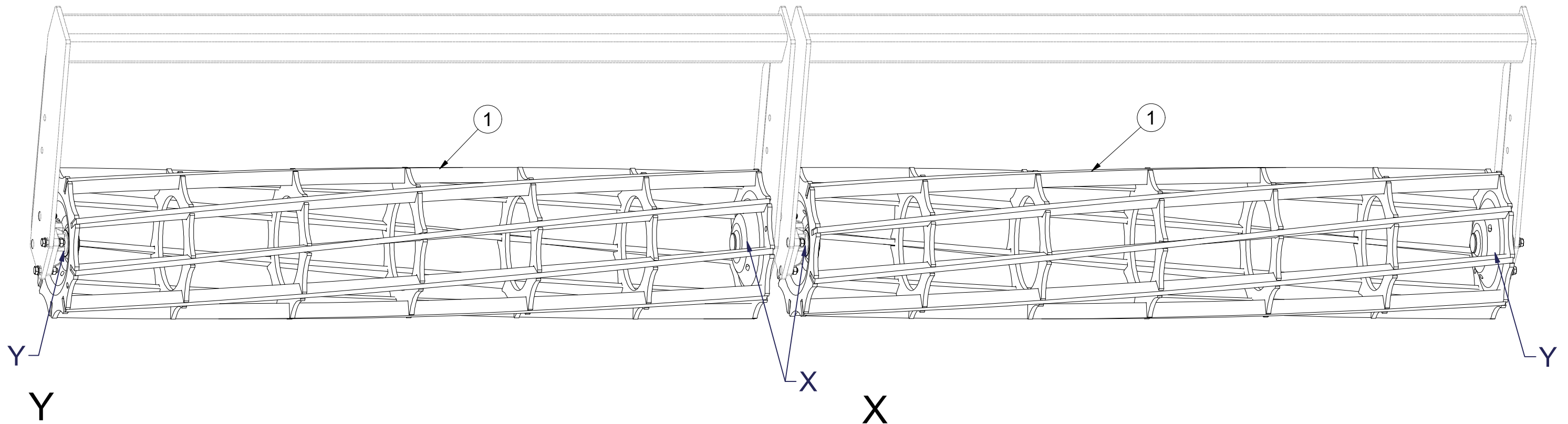

Pos.	Part Number	Pcs.
1	2000679	2
10	m03519	12
11	m04412	4
20	m01305	16
30	m03988	16
31	m17741	4

(CZ) SADA LOŽISEK
 (D) SATZ LAGER
 (F) KIT DE ROULEMENTS

(GB) SET OF BEARINGS
 (RU) КОМПЛЕКТ ПОДШИПНИКОВ
 (PL) ZESTAW ŁOŻYSK



VZ00012656

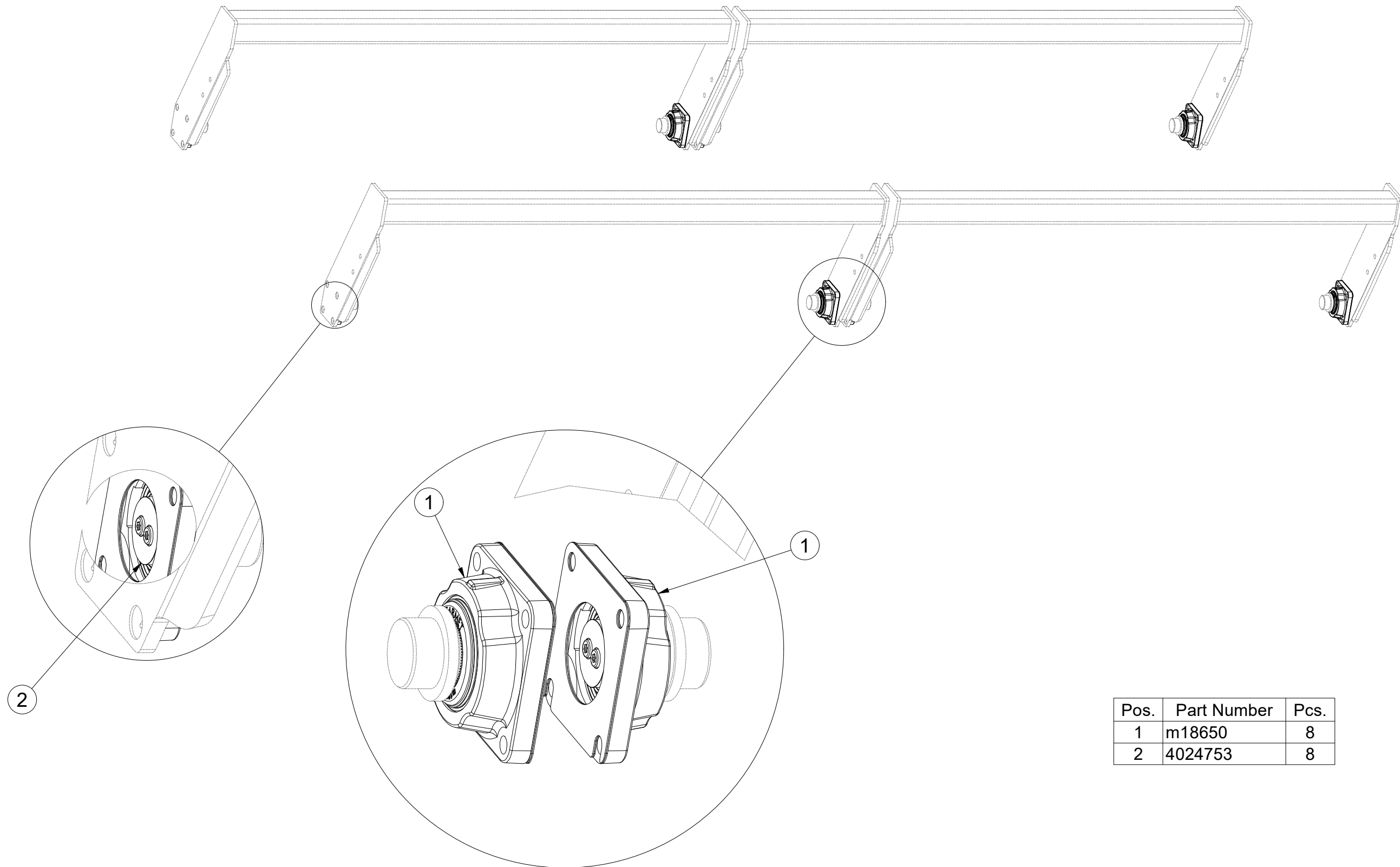

Pos.	Part Number	Pcs.
1	m18650	8
2	4024753	8

- Ⓒ SADA LOŽISEK
- Ⓓ SATZ LAGER
- Ⓕ KIT DE ROULEMENTS

- Ⓖ SET OF BEARINGS
- Ⓡ КОМПЛЕКТ ПОДШИПНИКОВ
- Ⓟ ZESTAW ŁOŻYSK



VZ00012656

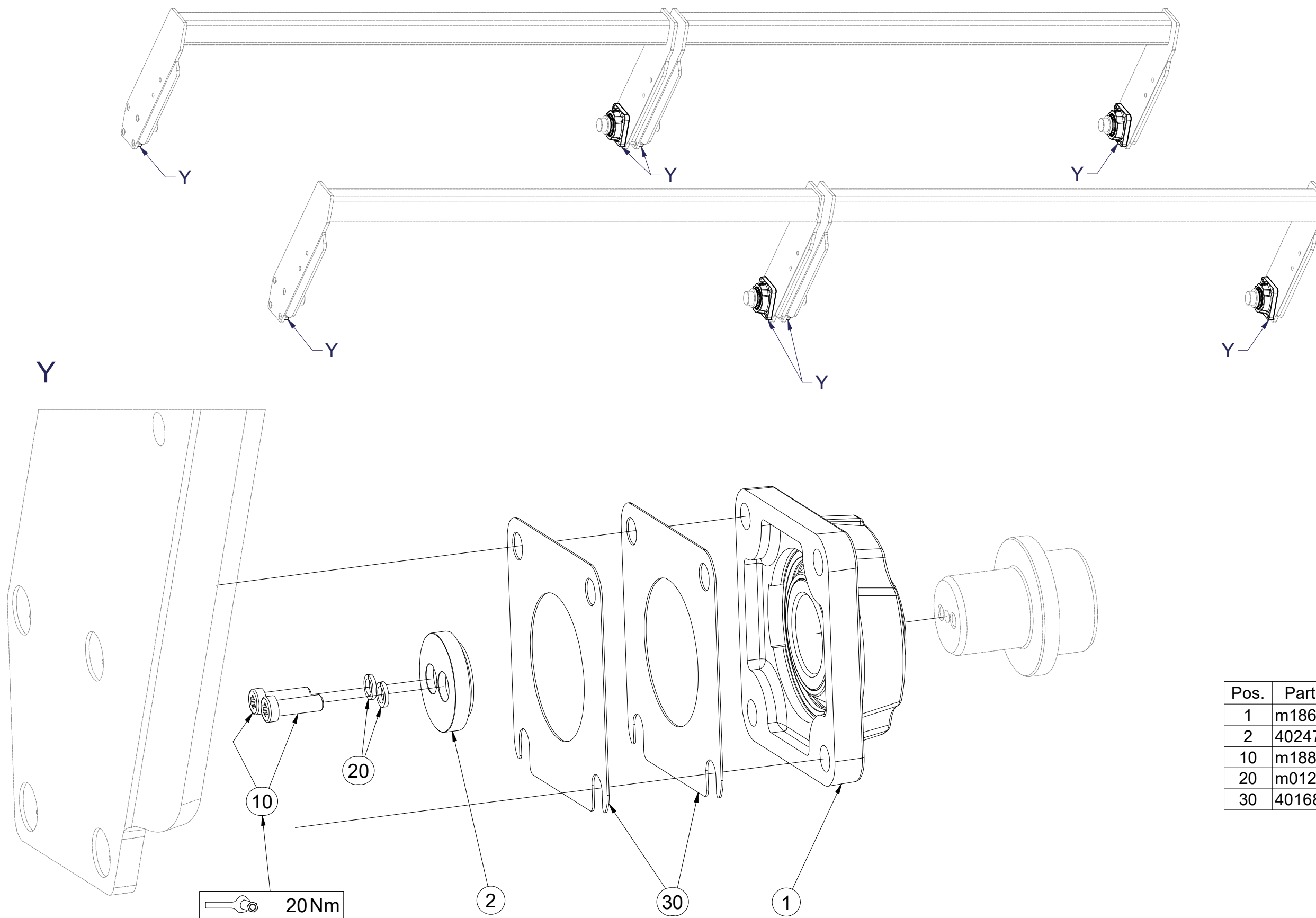

Pos.	Part Number	Pcs.
1	m18650	8
2	4024753	8
10	m18858	16
20	m01202	16
30	4016809	16

CZ SADA OVLÁDÁNÍ RADLICE
 D STEUERSATZ PFLUGSCHAREN
 F KIT DE COMMANDE DES SOCS

GB SET OF PLOUGHSHARE CONTROL
 RU КОМПЛЕКТ УПРАВЛЕНИЯ ЛАП
 PL ZESTAW STEROWANIA RADLICAMI



3011961

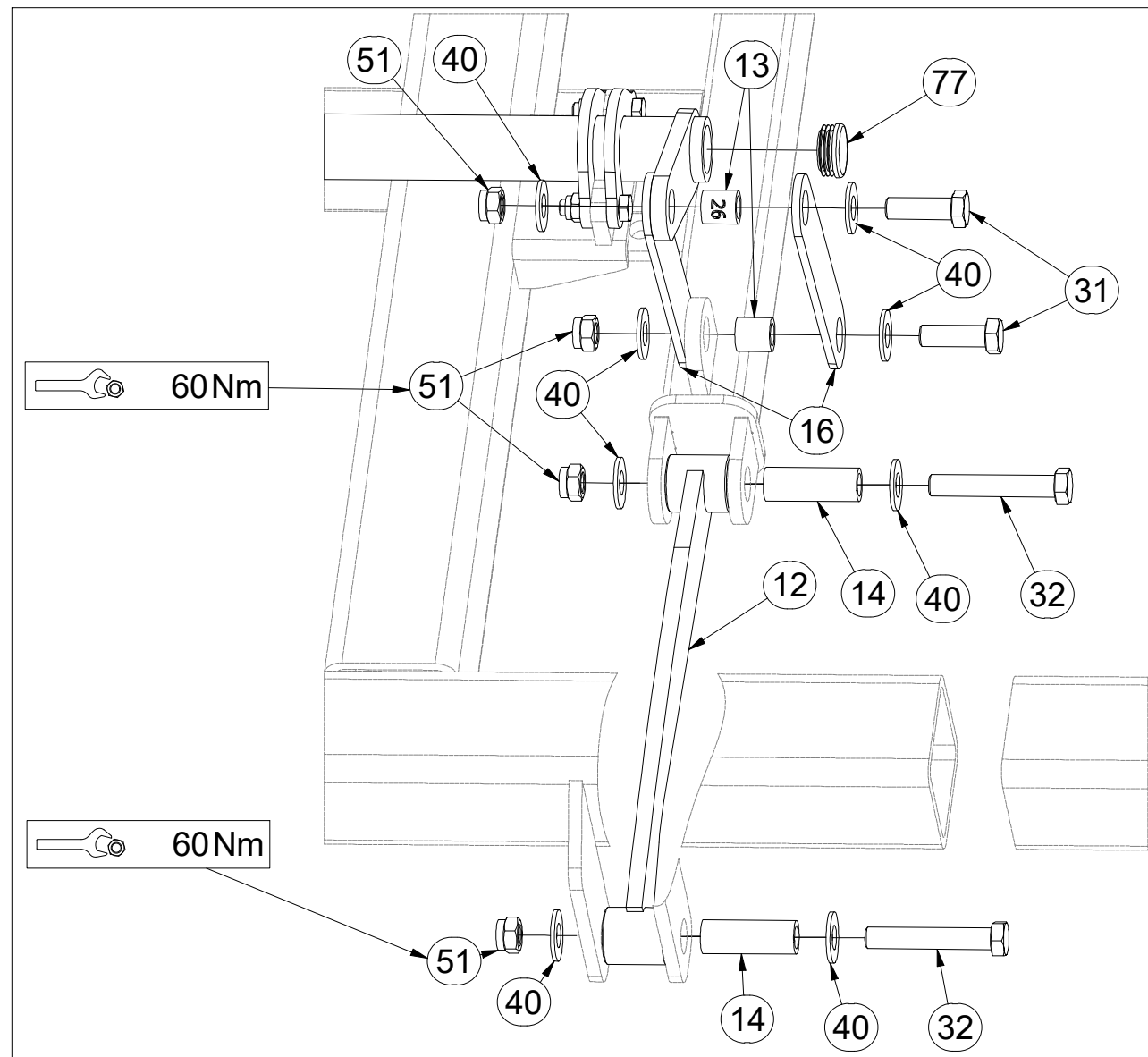
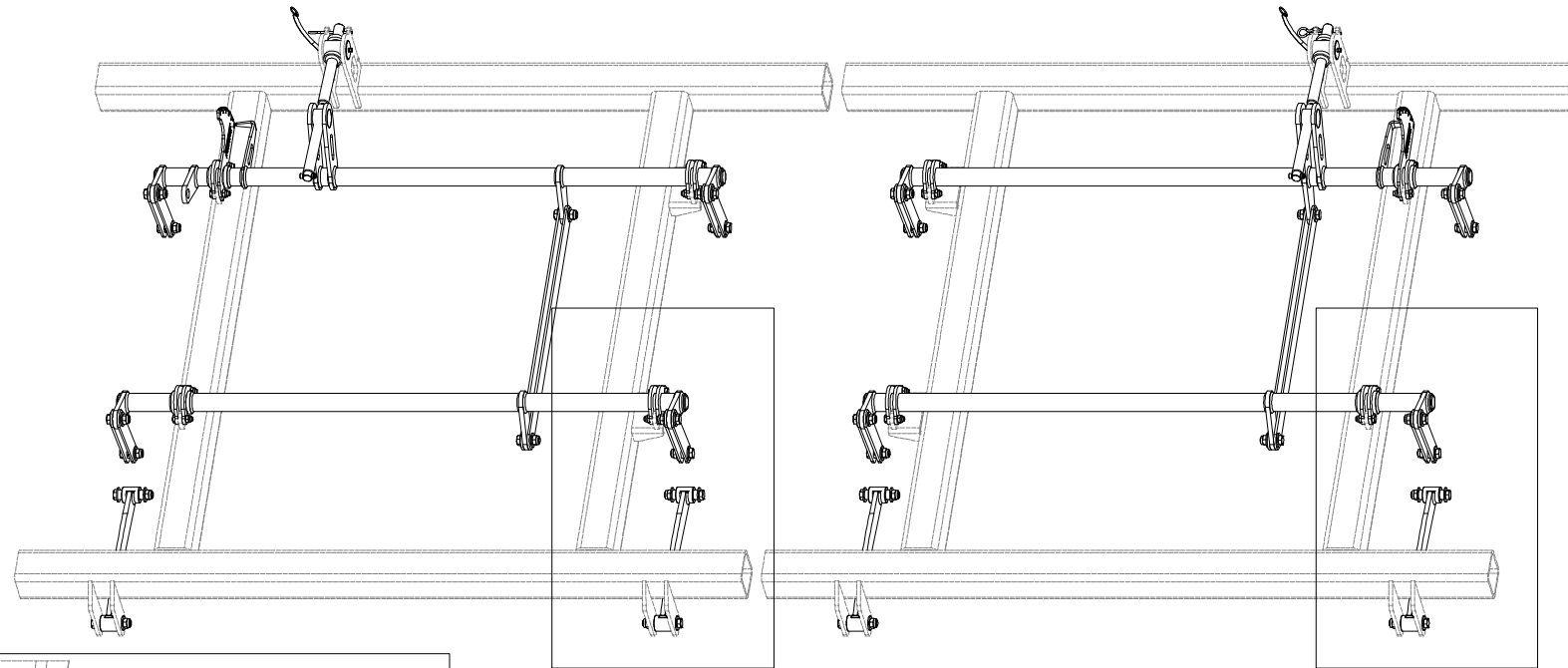

Pos.	Part Number	Pcs.
12	VZ00003342	4
13	4002265	20
14	9001426	8
16	4005333	16
31	m04355	20
32	m07673	8
40	m05651	56
51	m03683	28
77	m10130	8

Ⓒ SADA OVLÁDÁNÍ RADLICE

Ⓓ STEUERSATZ PFLUGSCHAREN

Ⓕ KIT DE COMMANDE DES SOCS

Ⓖ SET OF PLOUGHSHARE CONTROL

Ⓡ КОМПЛЕКТ УПРАВЛЕНИЯ ЛАП

Ⓢ ZESTAW STEROWANIA RADLICAMI



3011961

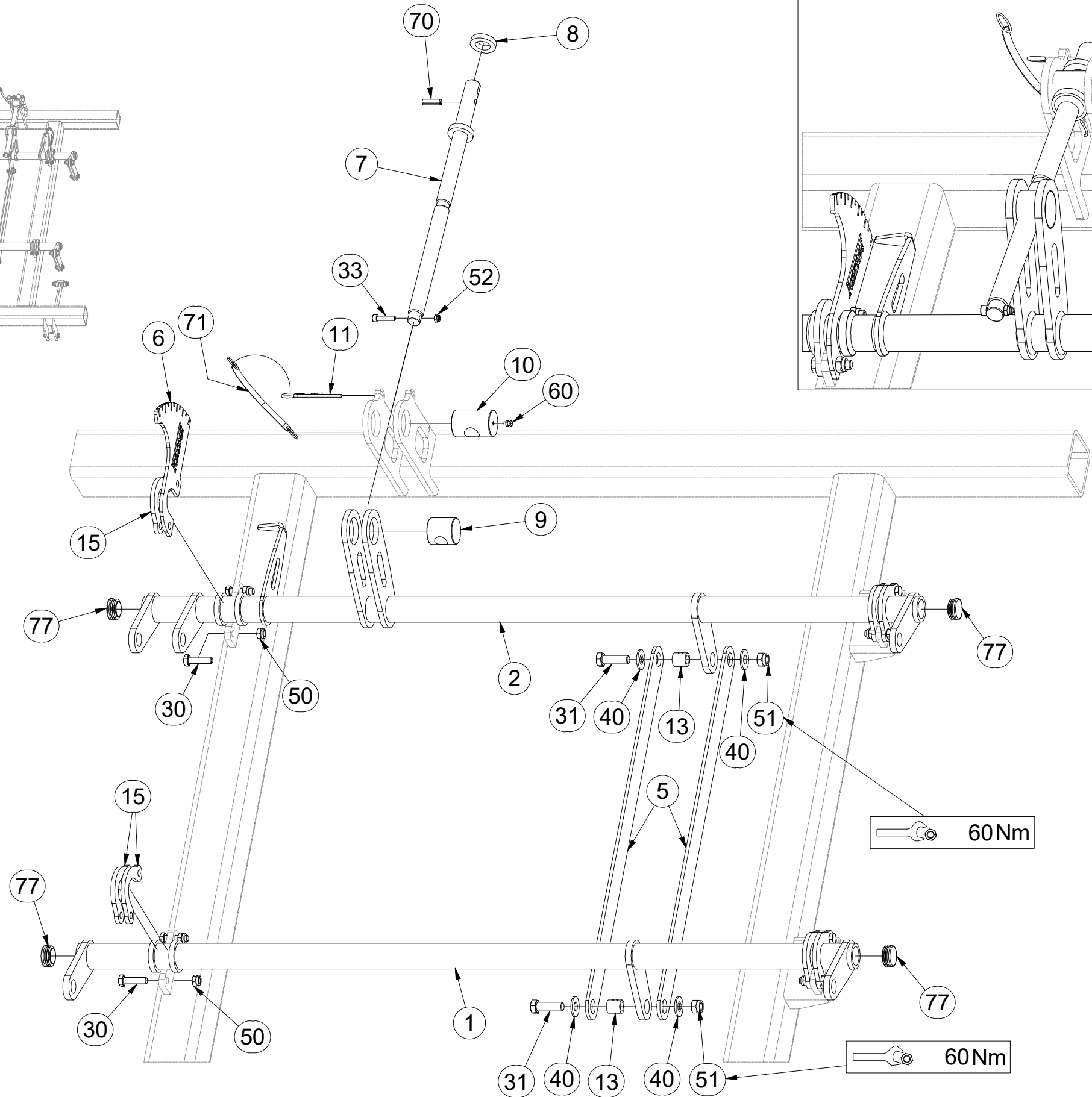
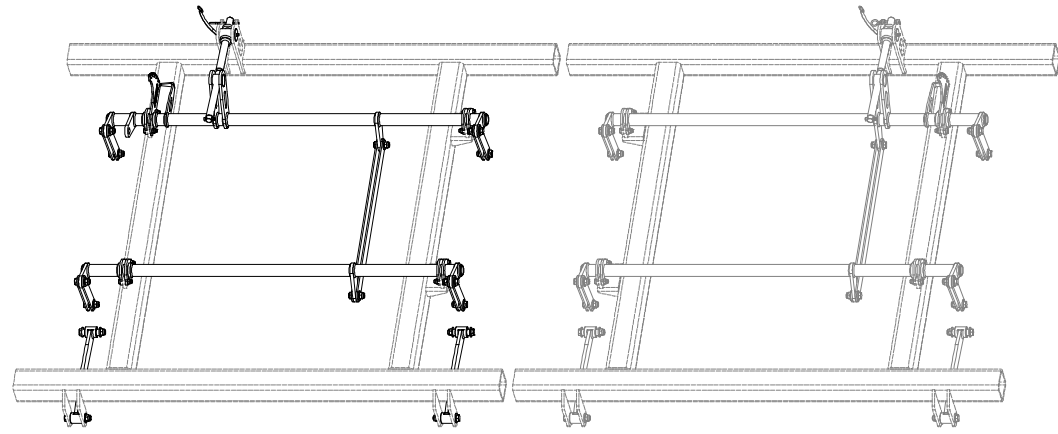

Pos.	Part Number	Pcs.
1	3004116	1
2	3009175	1
5	4005334	4
6	4023896	2
7	4024250	2
8	9002560	2
9	4005340	2
10	9002114	2
11	m09988	2
13	4002265	20
15	4005332	14
30	m06077	16
31	m04355	20
33	m09464	2
40	m05651	56
50	m04301	16
51	m03683	28
52	m04503	2
60	m10451	2
70	m10736	2
71	m12467	2
77	m10130	8

Ⓒ SADA OVLÁDÁNÍ RADLICE

Ⓓ STEUERSATZ PFLUGSCHAREN

Ⓕ KIT DE COMMANDE DES SOCS

Ⓖ SET OF PLOUGHSHARE CONTROL

Ⓡ КОМПЛЕКТ УПРАВЛЕНИЯ ЛАП

Ⓢ ZESTAW STEROWANIA RADLICAMI



3011961

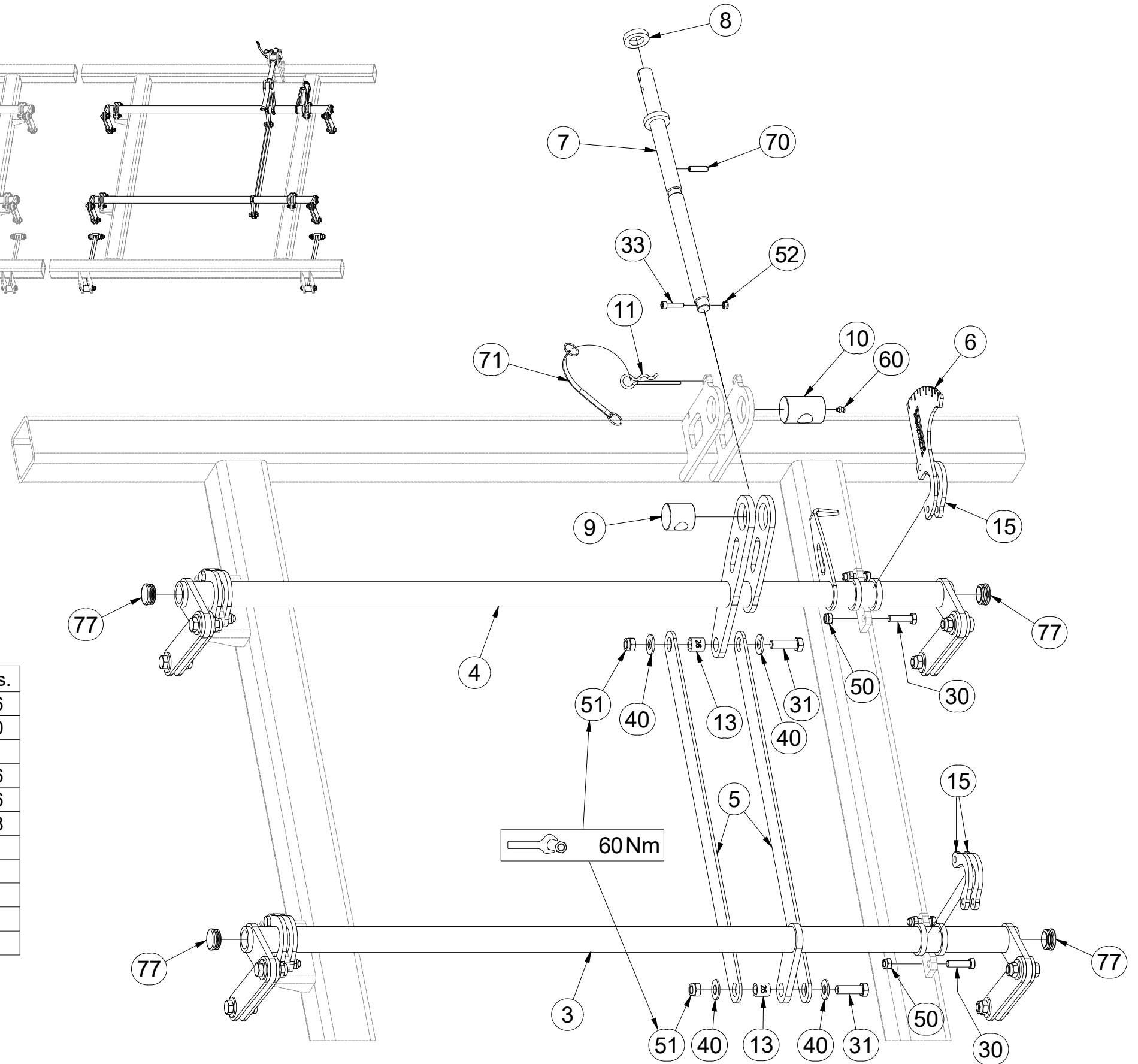
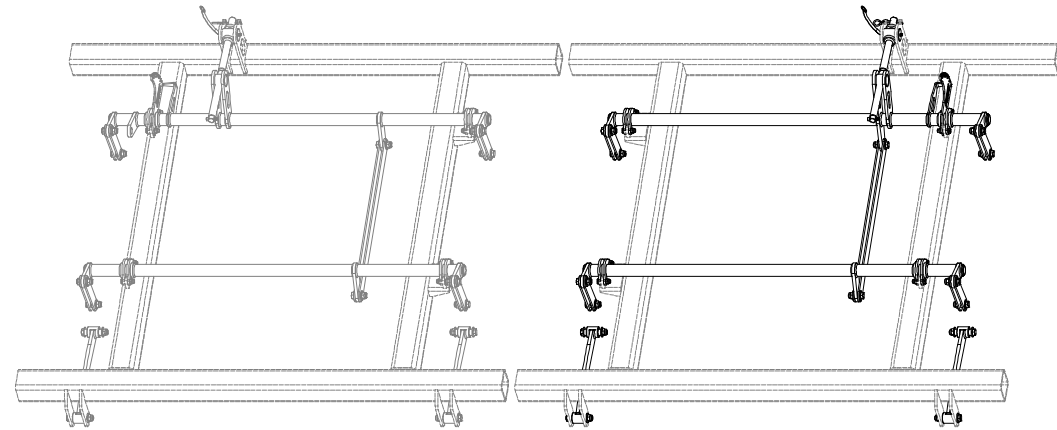
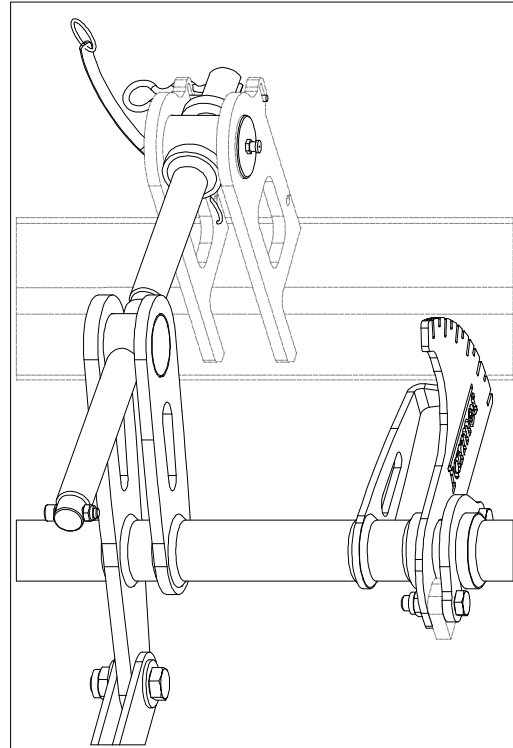

Pos.	Part Number	Pcs.	Pos.	Part Number	Pcs.
3	3004115	1	30	m06077	16
4	3003348	1	31	m04355	20
5	4005334	4	33	m09464	2
6	4023896	2	40	m05651	56
7	4024250	2	50	m04301	16
8	9002560	2	51	m03683	28
9	4005340	2	52	m04503	2
10	9002114	2	60	m10451	2
11	m09988	2	70	m10736	2
13	4002265	20	71	m12467	2
15	4005332	14	77	m10130	8

ⒸZ SADA RADLIC

Ⓓ SCHARSATZ

Ⓕ KIT DE SOCS

ⒸB SET OF PLOUGHSHARES

ⒸU КОМПЛЕКТ ЛАП

ⒸL ZESTAW REDLIC



3012371

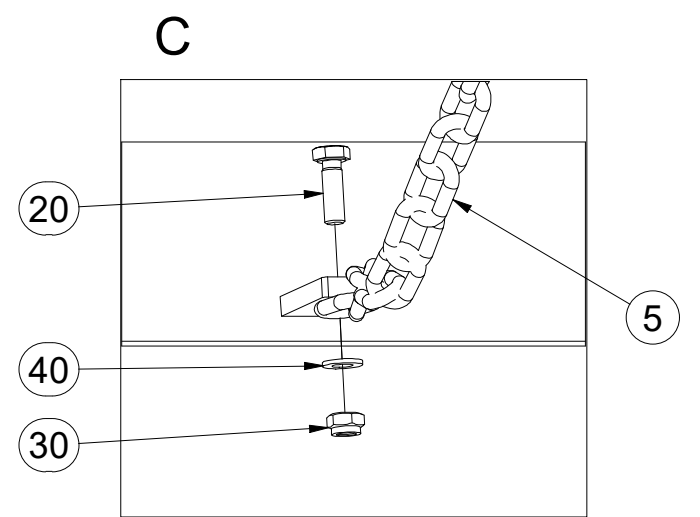
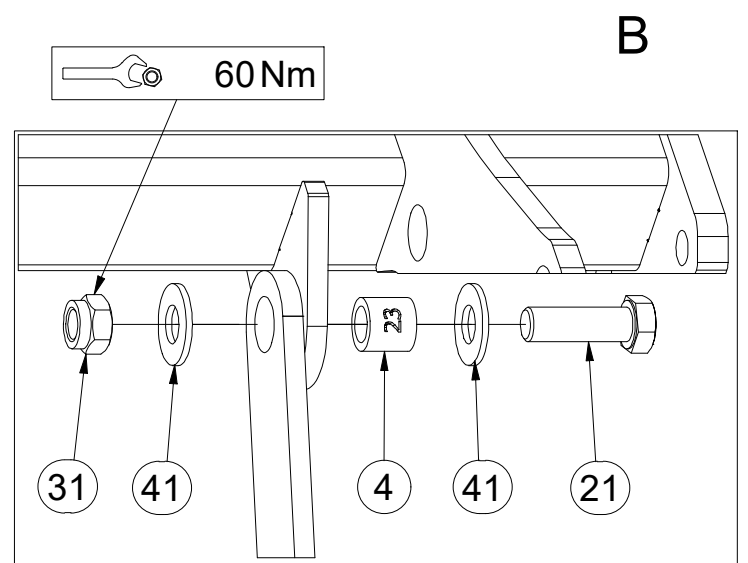
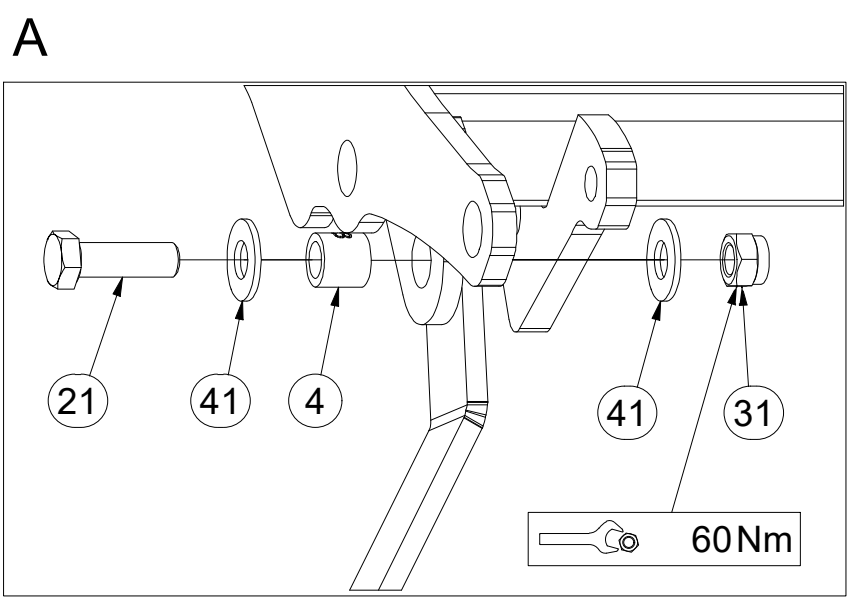
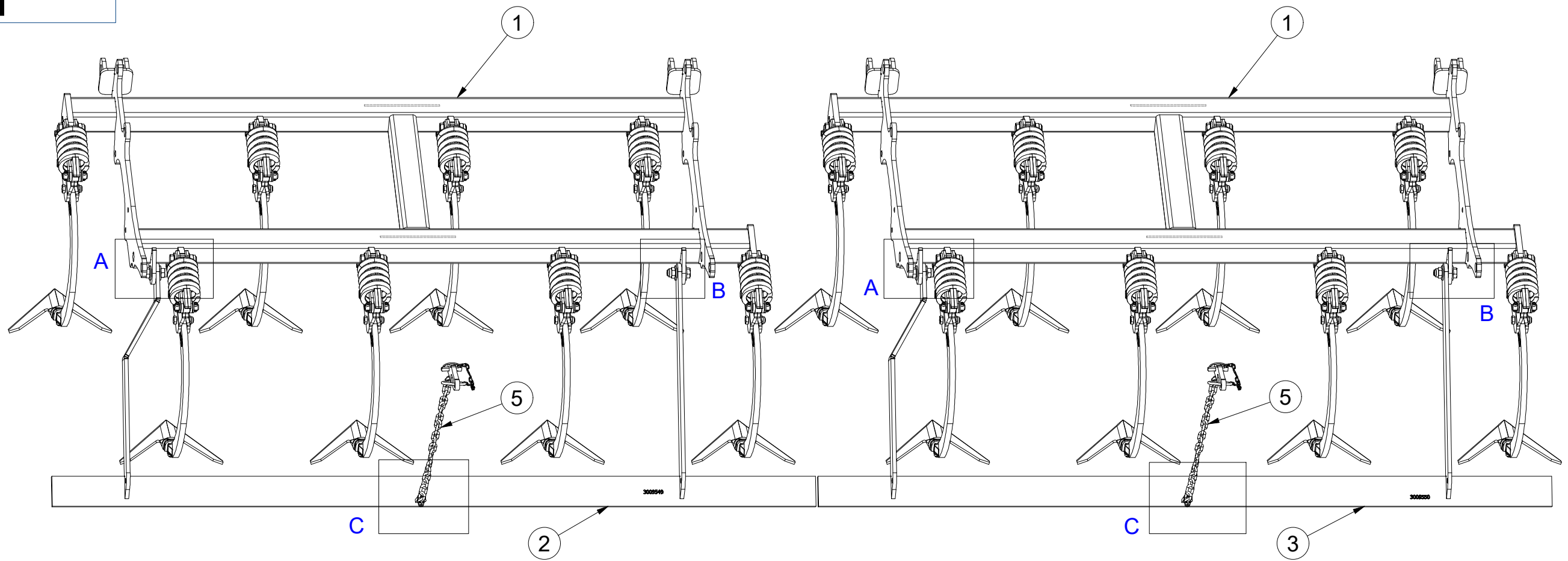

Pos.	Part Number	Pcs.
1	VZ00015183	2
2	3009549	1
3	3009550	1
4	4022223	4
5	4001641	2
20	m01092	2
21	m04355	4
30	m04503	2
31	m03683	4
40	m01203	2
41	m05651	8

Ⓒ SADA RADLIC

Ⓓ SCHARSATZ

Ⓕ KIT DE SOCS

Ⓖ SET OF PLOUGHSHARES

Ⓡ КОМПЛЕКТ ЛАП

Ⓟ ZESTAW REDLIC



VZ00015183

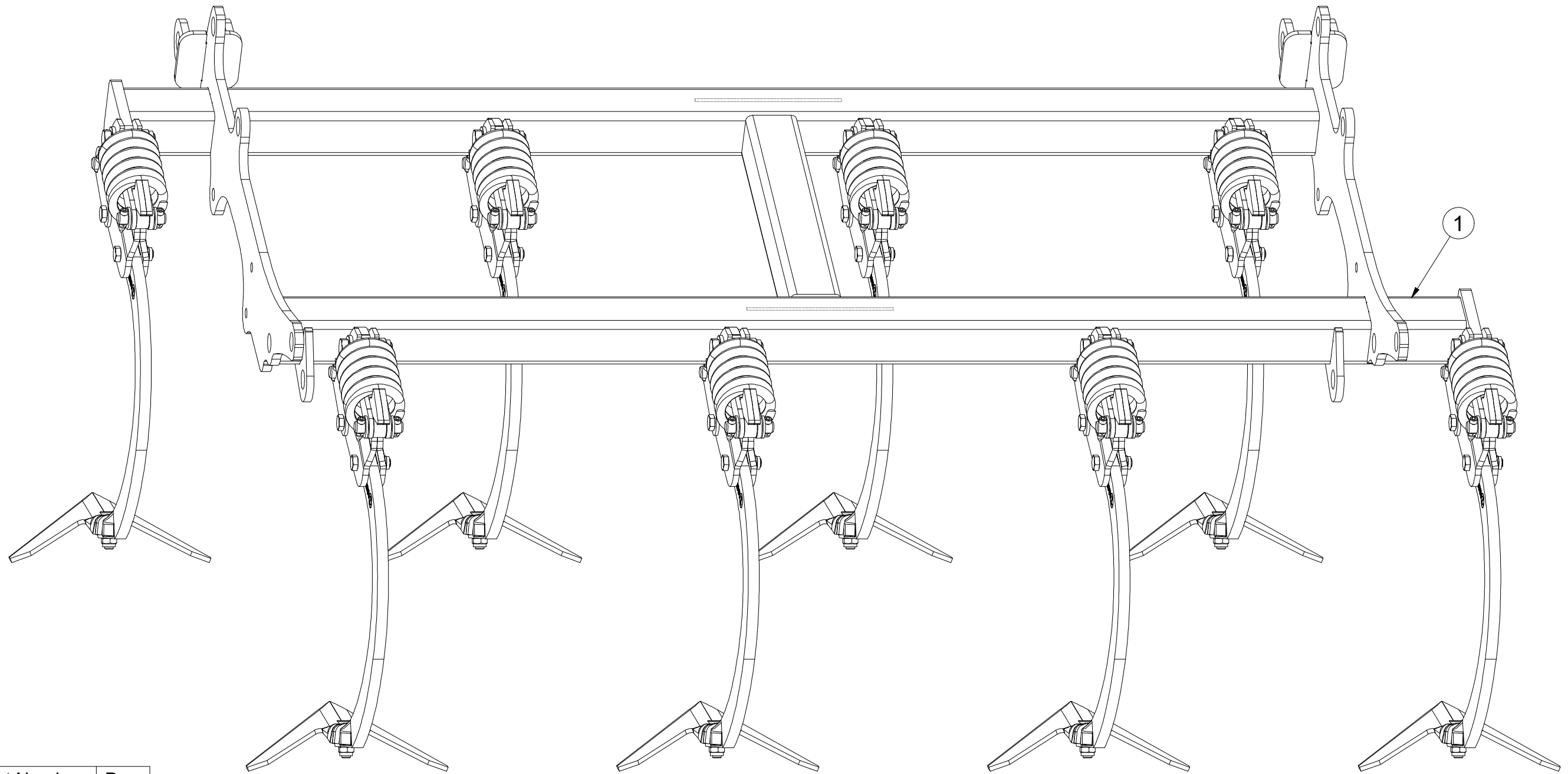

Pos.	Part Number	Pcs.
1	VZ00015184	1

Ⓒ SADA RADLIC

Ⓓ SCHARSATZ

Ⓕ KIT DE SOCS

VZ00015183

Ⓖ SET OF PLOUGHSHARES

Ⓡ КОМПЛЕКТ ЛАП

Ⓢ ZESTAW REDLIC

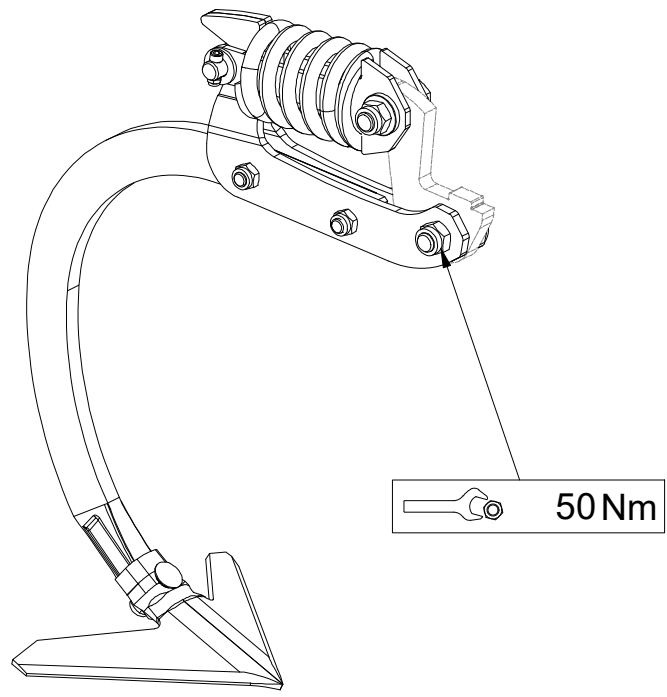
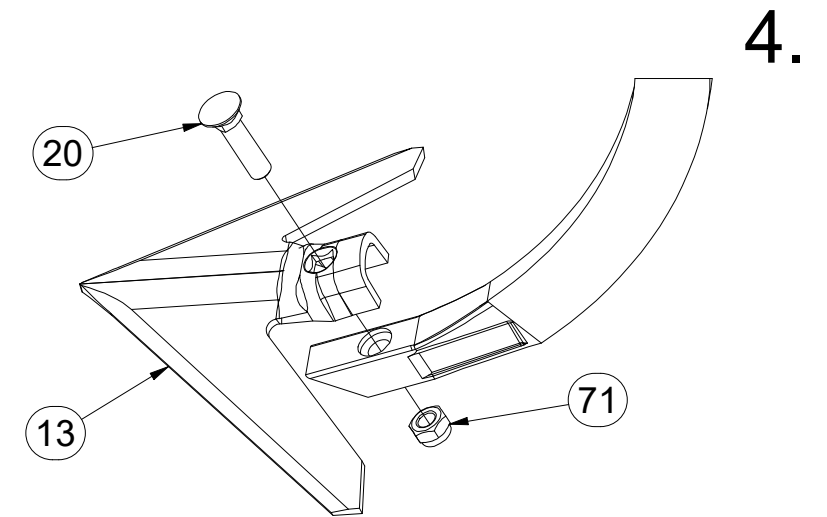
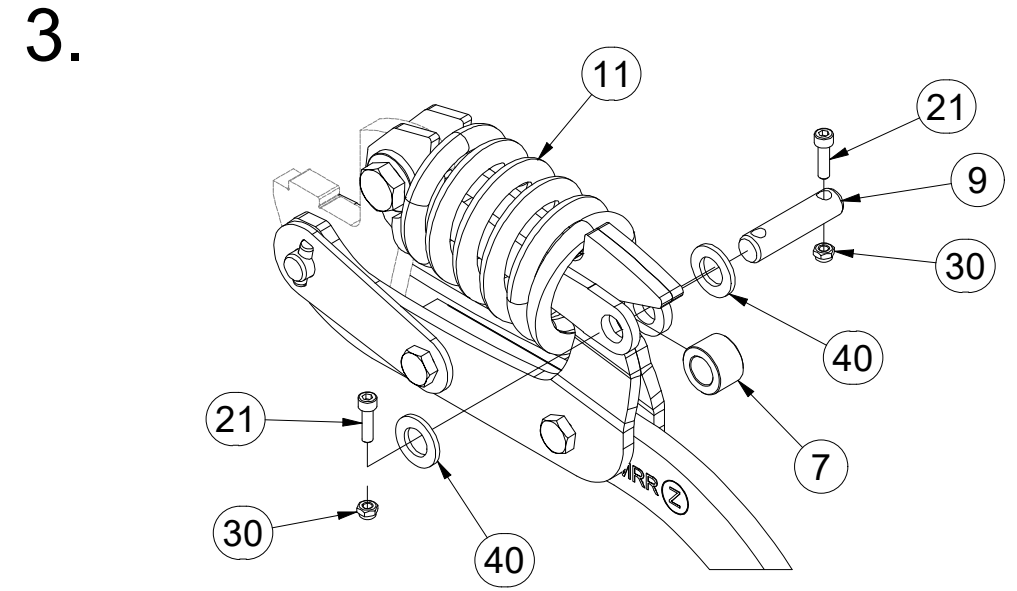
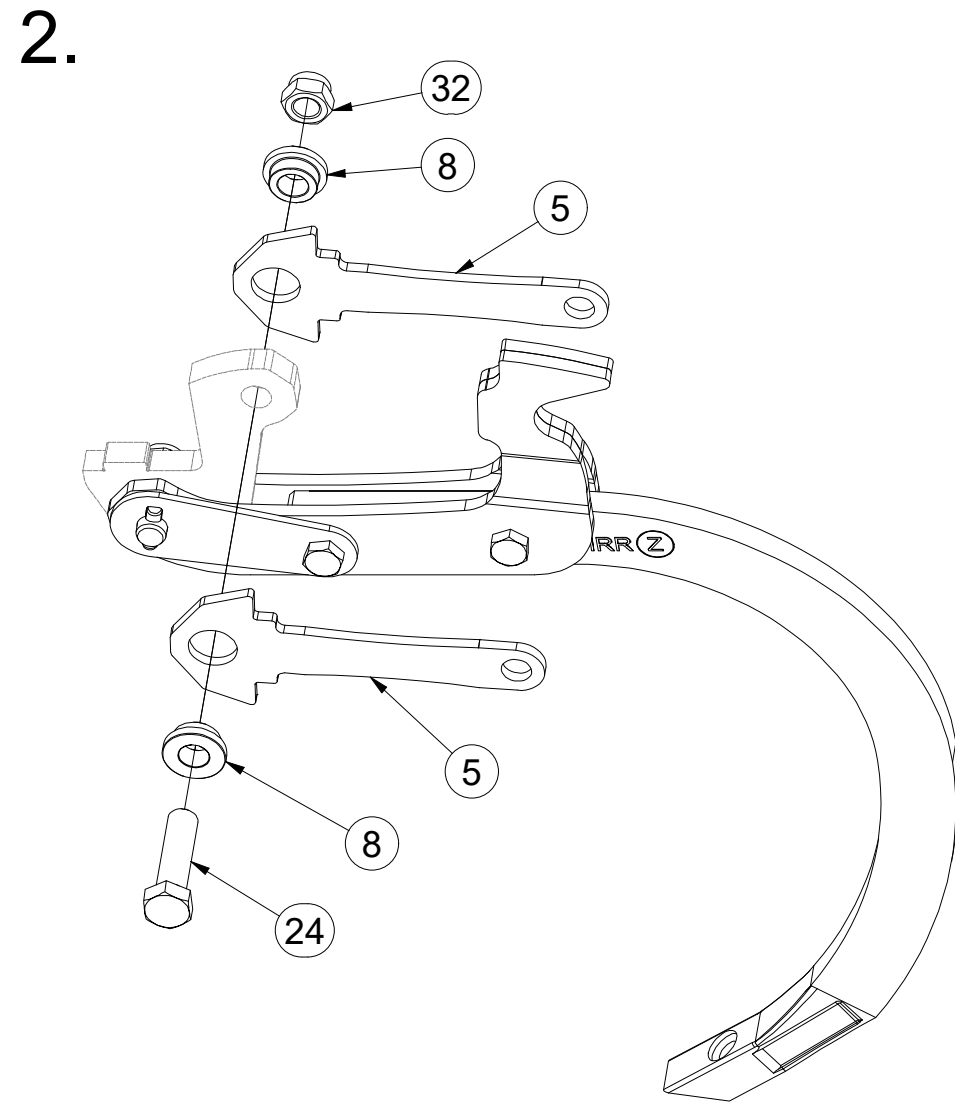
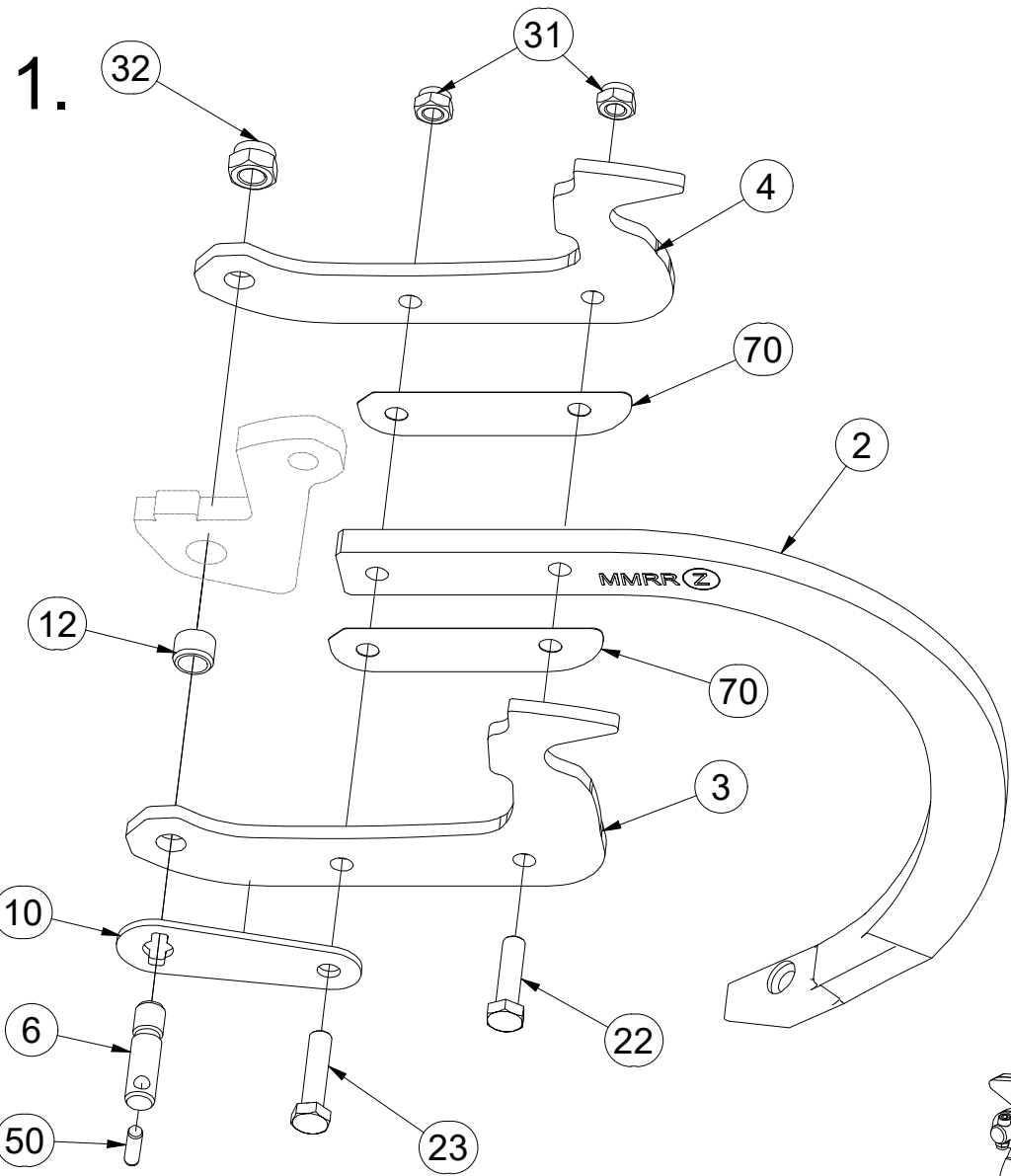

Pos.	Part Number	Pcs.	Pos.	Part Number	Pcs.
2	9005683	8	20	m10440	8
3	3012358	8	21	m15215	16
4	3012359	8	22	m06077	8
5	4024906	16	23	m03339	8
6	4024918	8	24	m14482	8
7	4009624	8	30	m05560	16
8	4014252	16	31	m04301	16
9	4015783	8	32	m03683	16
10	VZ00003688	8	40	m14971	16
11	m18880	8	50	m18826	8
12	m18882	8	70	4014863	16
13	3000236-KOO	8	71	m21001	8

- Ⓒ SADA ZADNÍCH VÁLCŮ
- Ⓓ SATZ HINTERE WALZEN
- Ⓕ KIT DE ROULEAUX ARRIÈRE

- Ⓖ SET OF REAR ROLLERS
- Ⓡ КОМПЛЕКТ ЗАДНИХ КАТКОВ
- Ⓟ ZESTAW TYLNYCH WAŁÓW



VZ00019446

Pos.	Part Number	Pcs.
1	3011938	1
2	VZ00012656	1

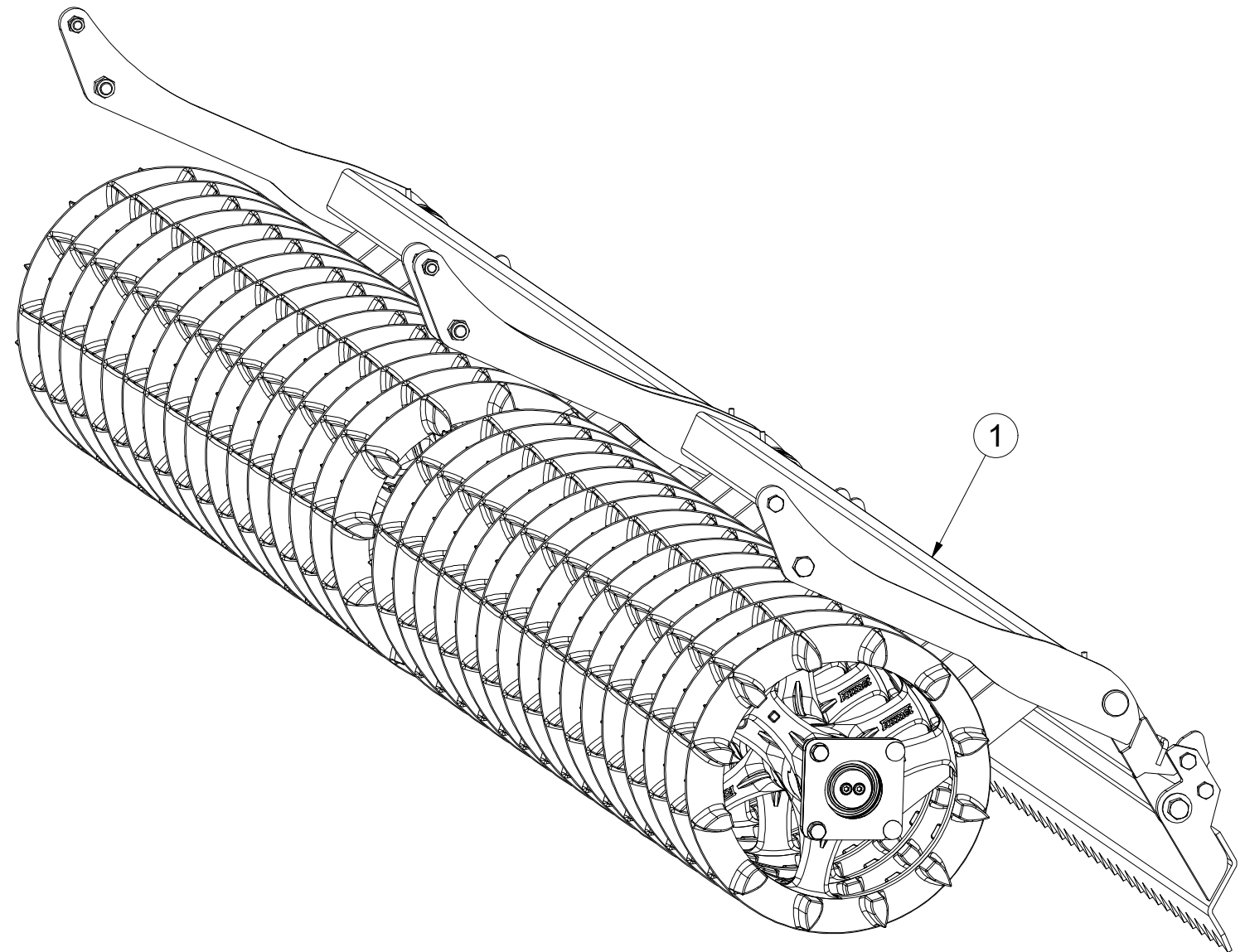
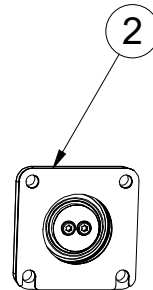
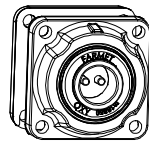
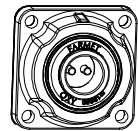

Ⓒ SADA ZADNÍCH VÁLCŮ

Ⓓ SATZ HINTERE WALZEN

Ⓕ KIT DE ROULEAUX ARRIÈRE

3011938

Ⓖ SET OF REAR ROLLERS

Ⓡ КОМПЛЕКТ ЗАДНИХ КАТКОВ

Ⓟ ZESTAW TYLNYCH WAŁÓW

Farmet

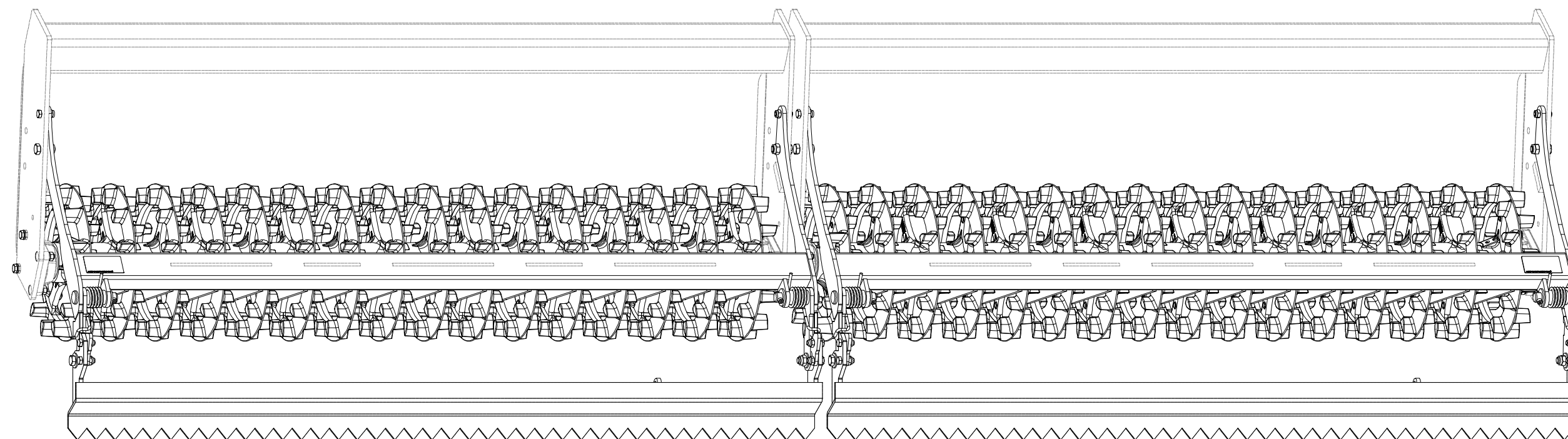

Ⓒ SADA ZADNÍCH VÁLCŮ

Ⓓ SATZ HINTERE WALZEN

Ⓕ KIT DE ROULEAUX ARRIÈRE

3011938

Ⓖ SET OF REAR ROLLERS

Ⓡ КОМПЛЕКТ ЗАДНИХ КАТКОВ

Ⓟ ZESTAW TYLNYCH WAŁÓW



Pos.	Part Number	Pcs.
2	3011293	2
9	VZ00011862	4
11	VZ00011865	28
27	4016995	4
57	m13958	8
100	4010015	8
101	4024556	8
110	m10516	0.80 ml

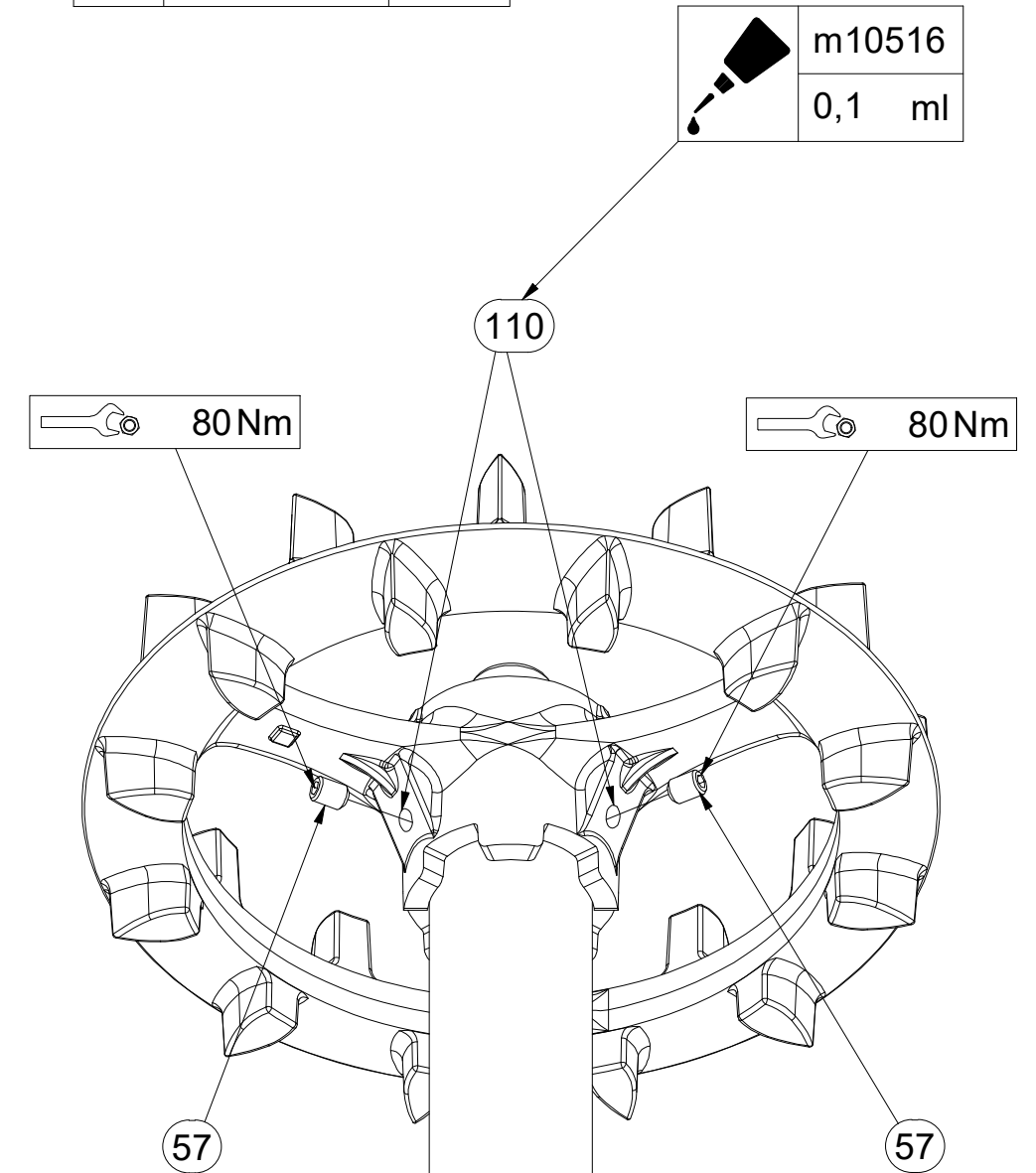
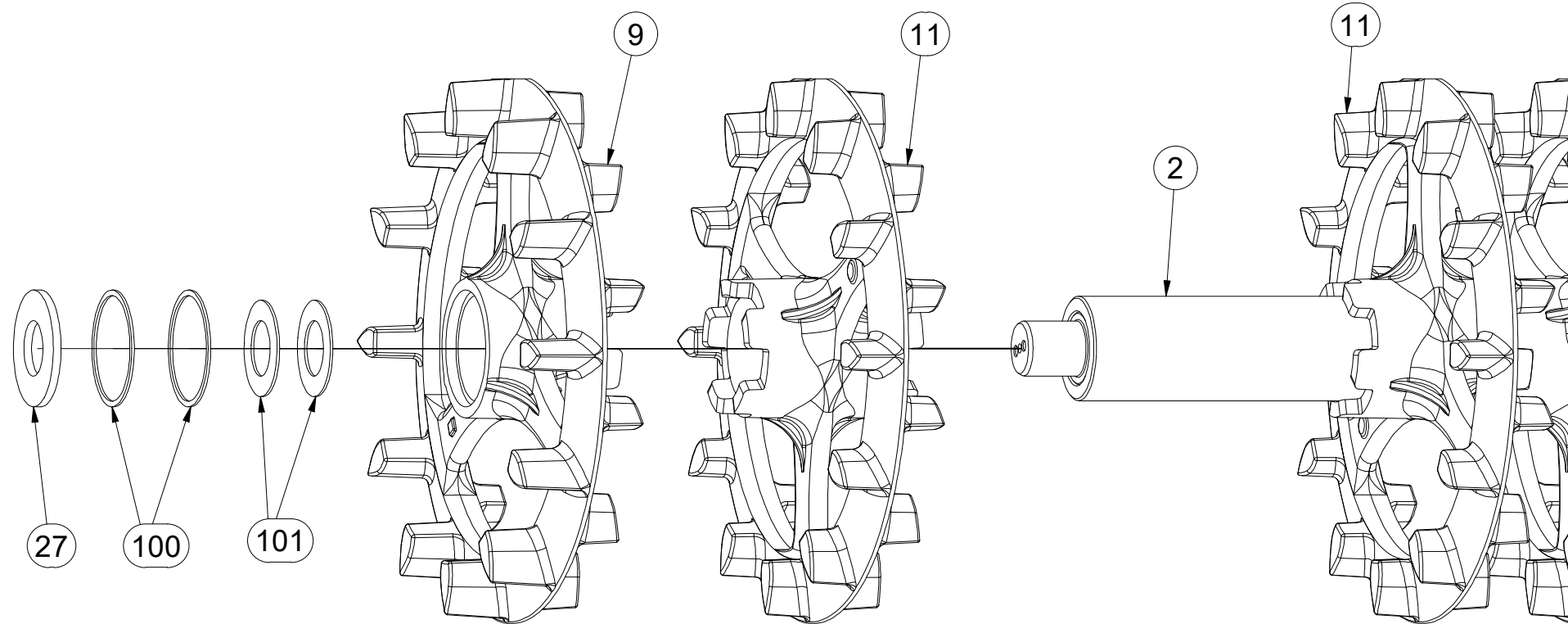

(CZ) SADA ZADNÍCH VÁLČŮ
 (D) SATZ HINTERE WALZEN
 (F) KIT DE ROULEAUX ARRIÈRE

(GB) SET OF REAR ROLLERS
 (RU) КОМПЛЕКТ ЗАДНИХ КАТКОВ
 (PL) ZESTAW TYLNYCH WAŁÓW



3011938

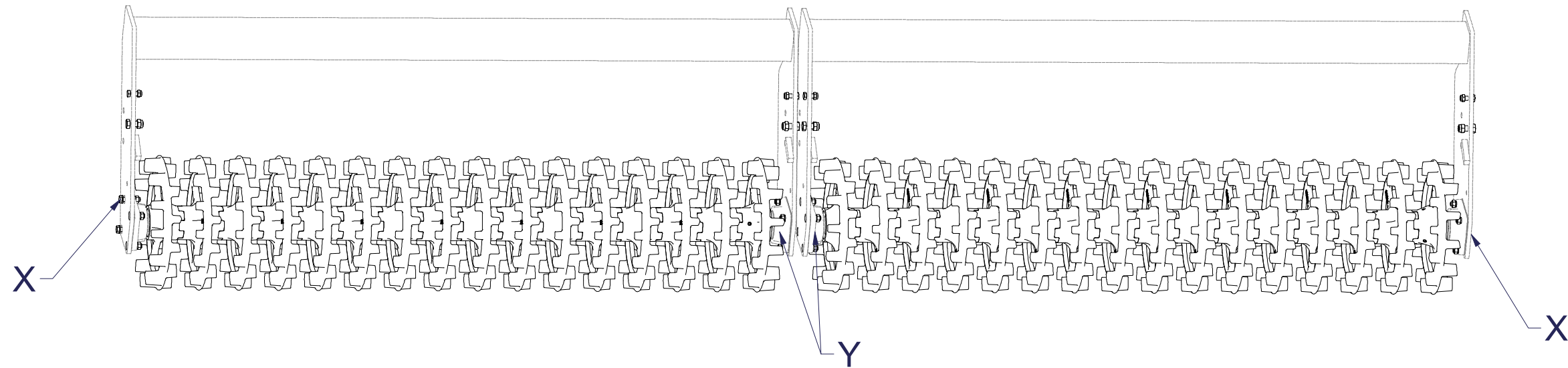

Pos.	Part Number	Pcs.
52	m03519	12
53	m04412	4
60	m01305	16
71	m03988	16
72	m17741	4

X

Y

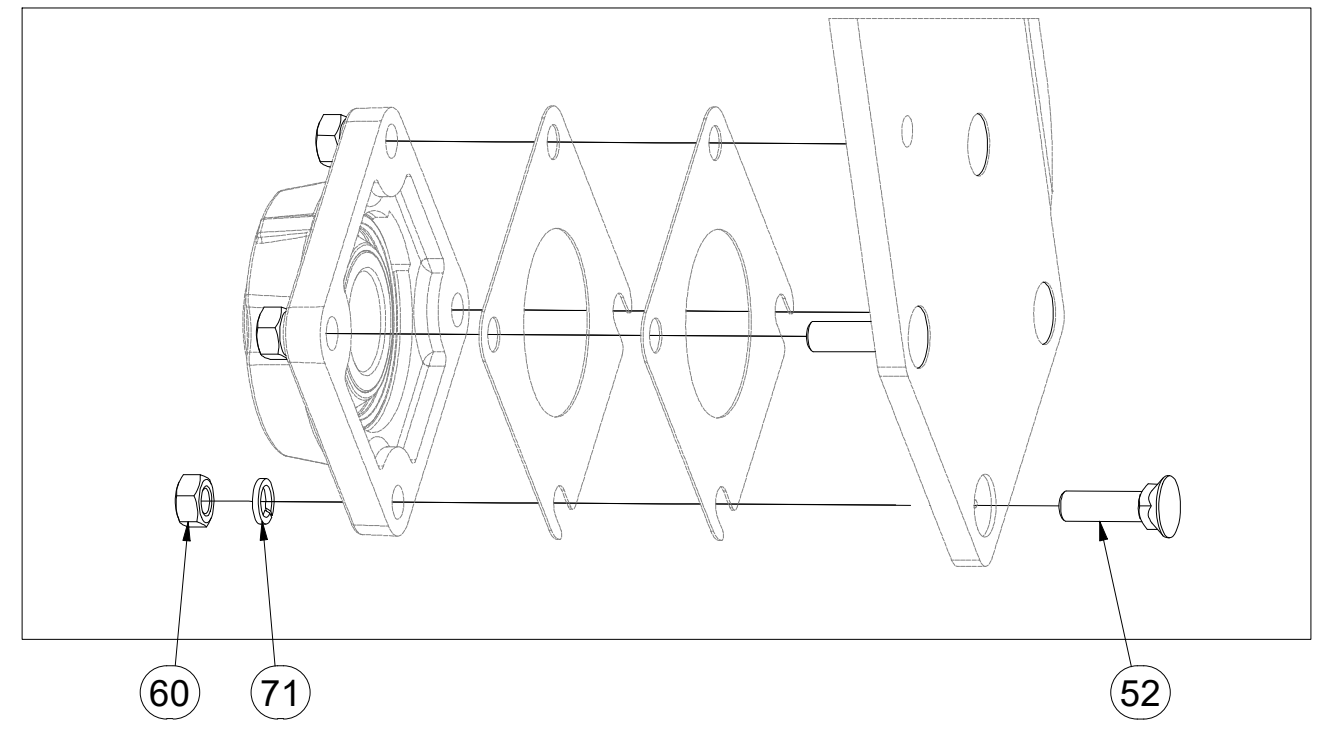
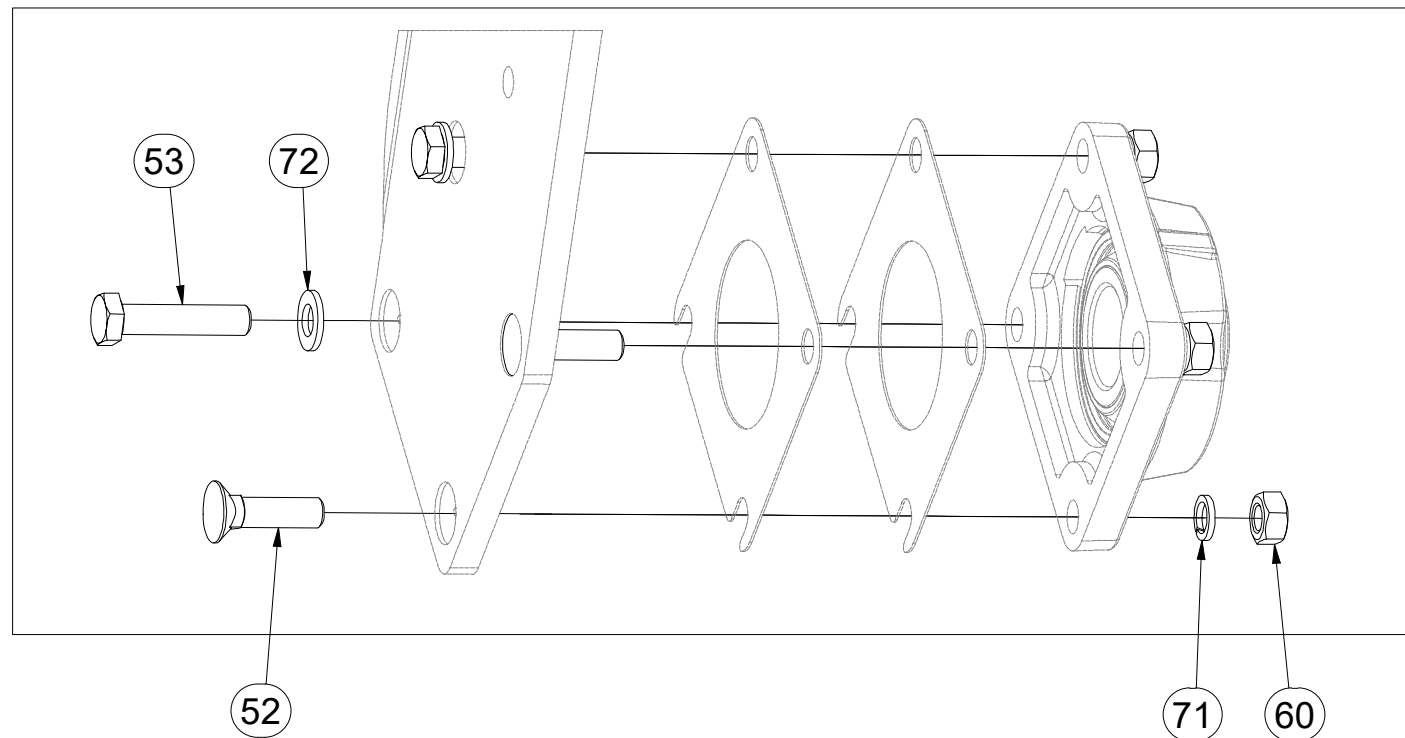

CZ SADA ZADNÍCH VÁLČŮ
 D SATZ HINTERE WALZEN
 F KIT DE ROULEAUX ARRIÈRE

GB SET OF REAR ROLLERS
 RU КОМПЛЕКТ ЗАДНИХ КАТКОВ
 PL ZESTAW TYLNYCH WAŁÓW



3011938

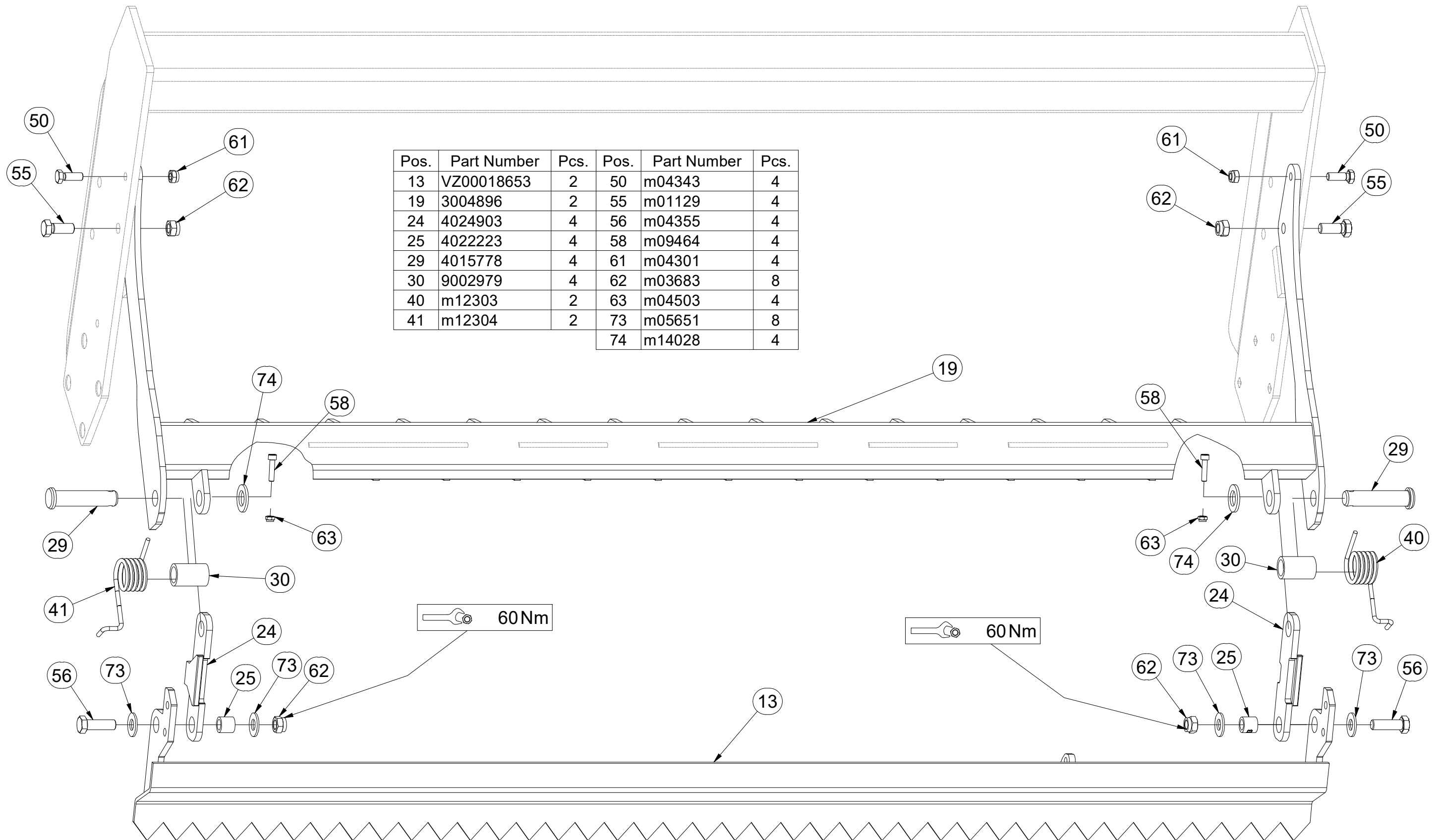

Pos.	Part Number	Pcs.	Pos.	Part Number	Pcs.
13	VZ00018653	2	50	m04343	4
19	3004896	2	55	m01129	4
24	4024903	4	56	m04355	4
25	4022223	4	58	m09464	4
29	4015778	4	61	m04301	4
30	9002979	4	62	m03683	8
40	m12303	2	63	m04503	4
41	m12304	2	73	m05651	8
			74	m14028	4

ⒸZ SADA DORAZŮ ZADNÍCH SMYKŮ

Ⓓ ANSCHLAGSATZ FÜR HINTERE ACKERSCHLEPPEN

Ⓕ KIT DE BUTÉES DES NIVELEURS ARRIÈRE

3006134

ⒼB SET OF REAR LEVELLING BAR STOPS

ⒺU КОМПЛЕКТ УПОРОВ ЗАДНИХ БОРОН

ⒽL ZESTAW DOCISKÓW TYLNYCH WŁÓK

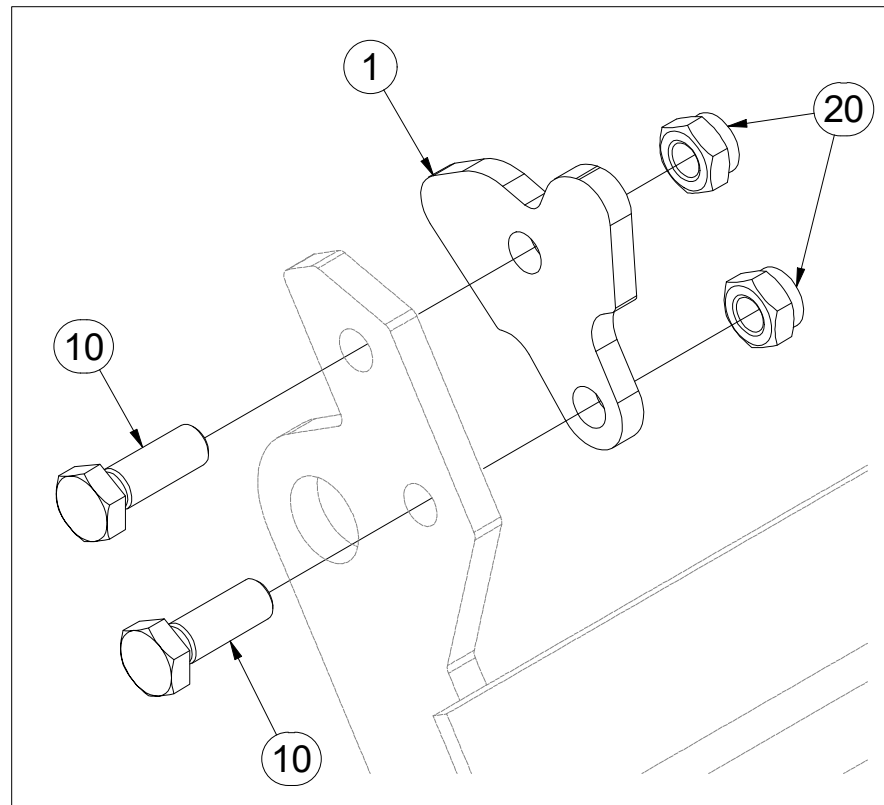

Pos.	Part Number	Pcs.
1	4013331	4
10	m04343	8
20	m04301	8

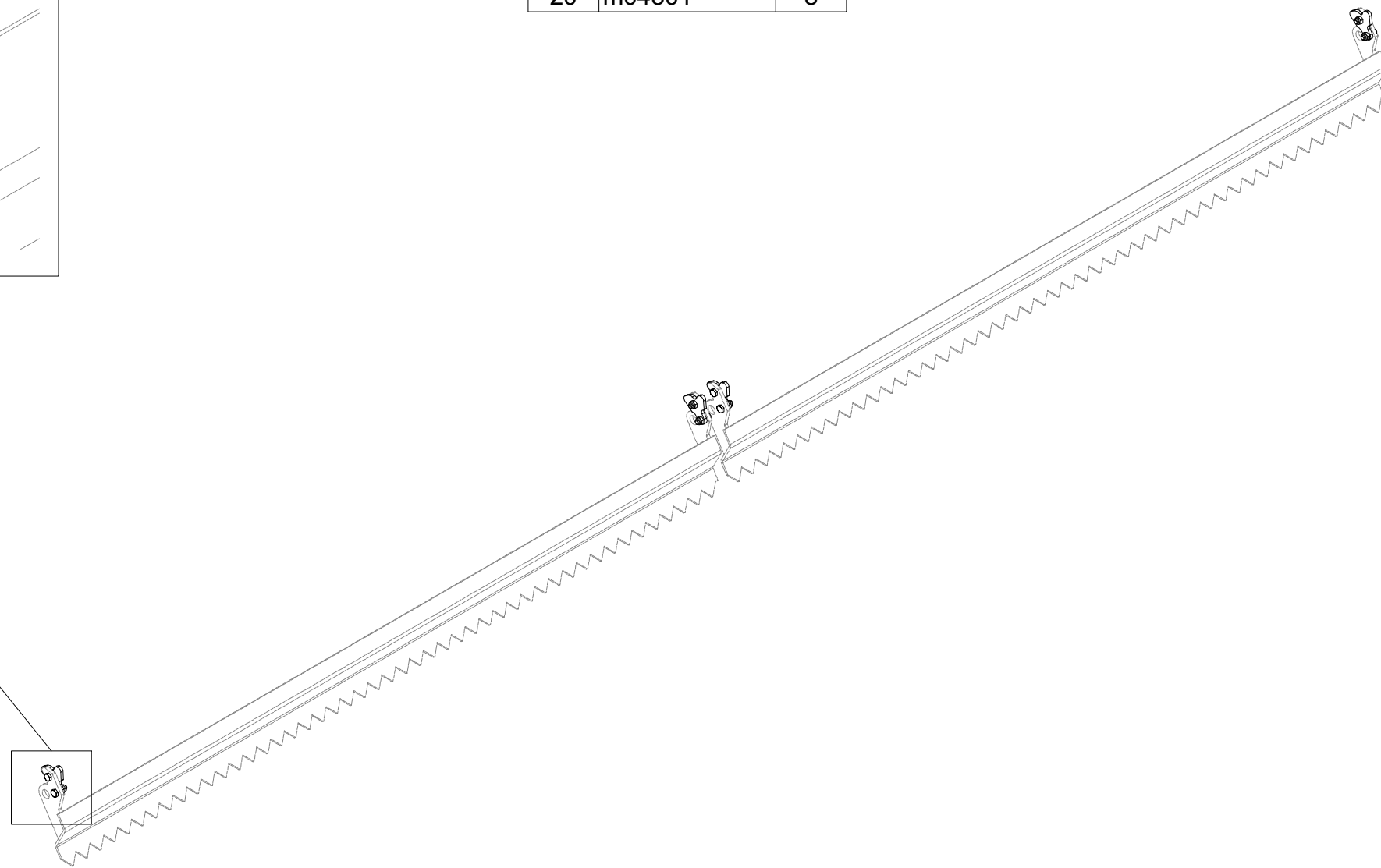

CZ SADA LOŽISEK
 D SATZ LAGER
 F KIT DE ROULEMENTS

GB SET OF BEARINGS
 RU КОМПЛЕКТ ПОДШИПНИКОВ
 PL ZESTAW ŁOŻYSK



VZ00012656

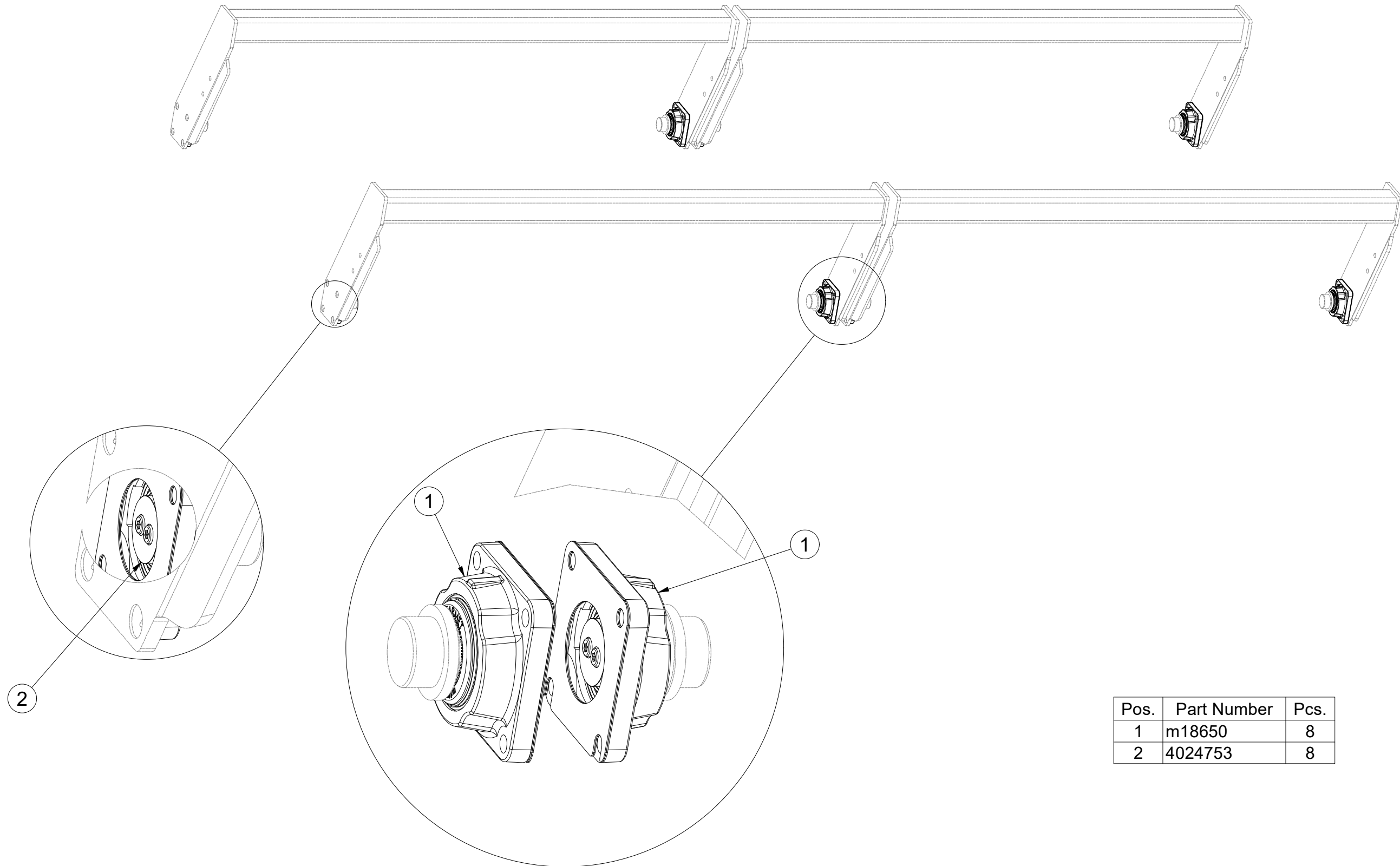

Pos.	Part Number	Pcs.
1	m18650	8
2	4024753	8

- Ⓒ SADA LOŽISEK
- Ⓓ SATZ LAGER
- Ⓕ KIT DE ROULEMENTS

- Ⓖ SET OF BEARINGS
- Ⓡ КОМПЛЕКТ ПОДШИПНИКОВ
- Ⓟ ZESTAW ŁOŻYSK



VZ00012656

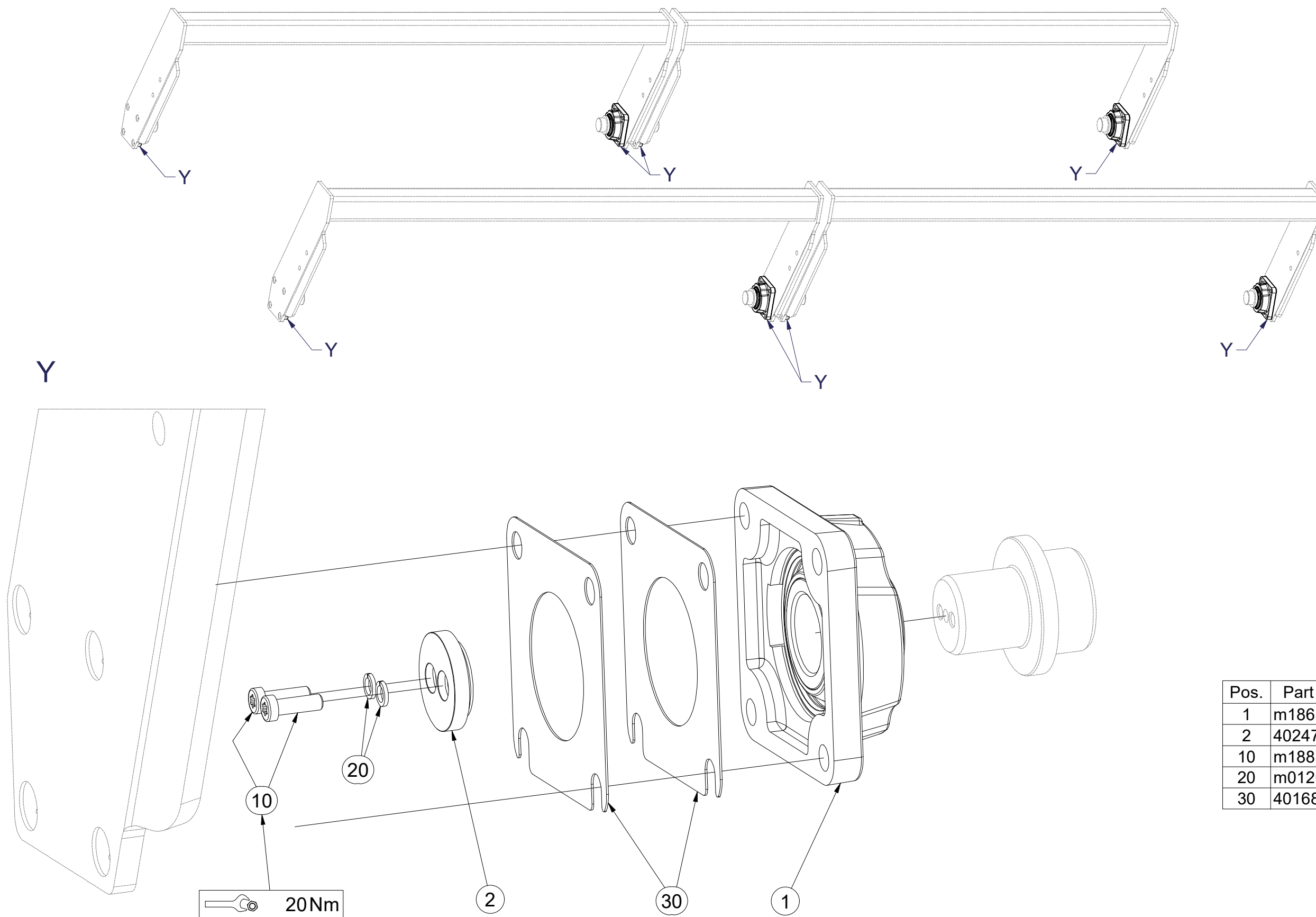

Pos.	Part Number	Pcs.
1	m18650	8
2	4024753	8
10	m18858	16
20	m01202	16
30	4016809	16

- Ⓒ CZ SADA NÁPRAVY
- Ⓓ D SATZ AUFHÄNGUNG
- Ⓕ F KIT DE L'ESSIEU

- Ⓖ GB AXLE SET
- Ⓡ RU КОМПЛЕКТ ОСИ КОЛЁС
- Ⓟ PL ZESTAW OSI



VZ00023761

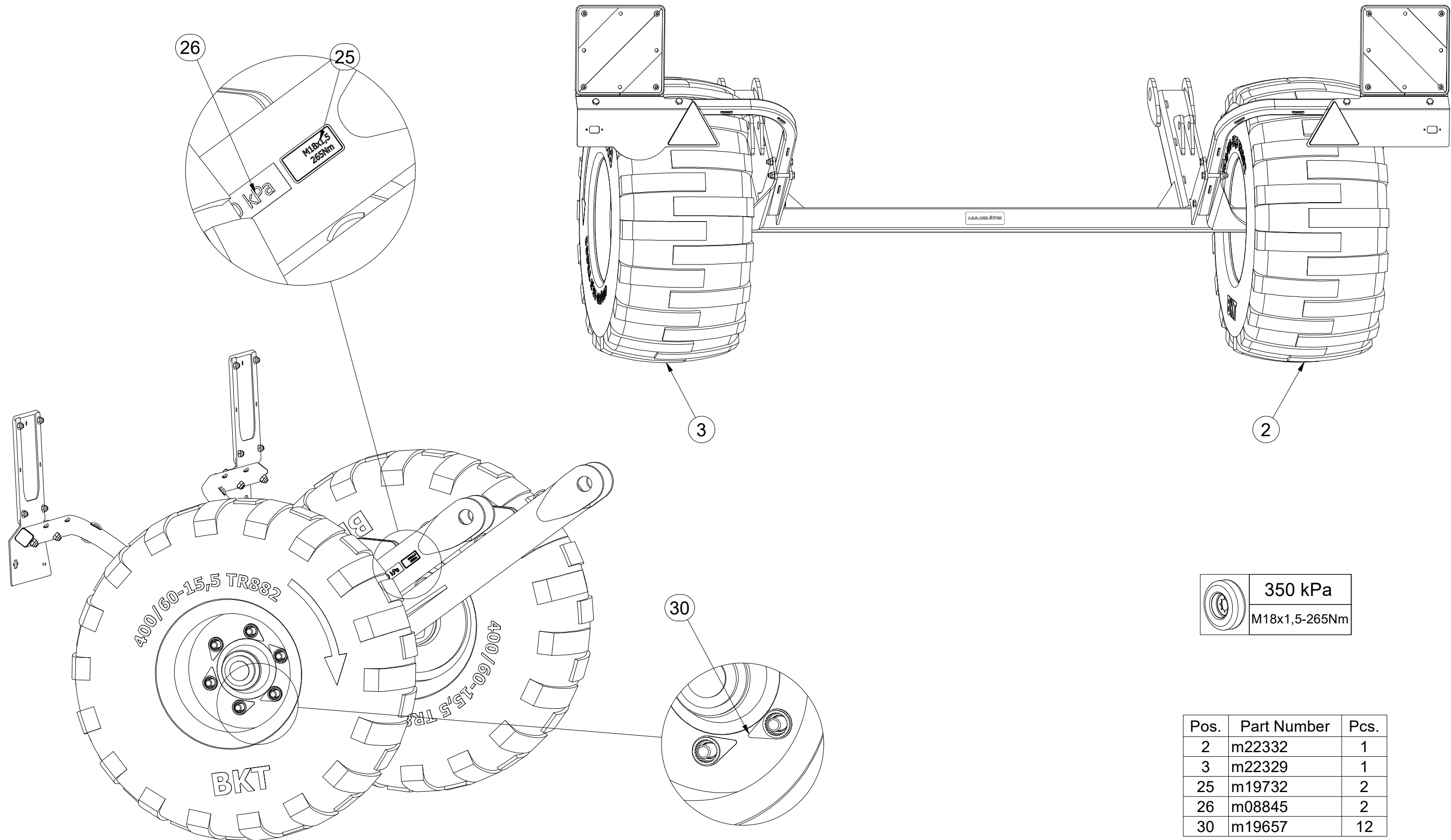

	350 kPa
	M18x1,5-265Nm

Pos.	Part Number	Pcs.
2	m22332	1
3	m22329	1
25	m19732	2
26	m08845	2
30	m19657	12

Ⓒ SADA NÁPRAVY

Ⓓ SATZ AUFHÄNGUNG

Ⓕ KIT DE L'ESSIEU

VZ00023761

Ⓖ AXLE SET

Ⓡ КОМПЛЕКТ ОСИ КОЛЁС

Ⓢ ZESTAW OSI

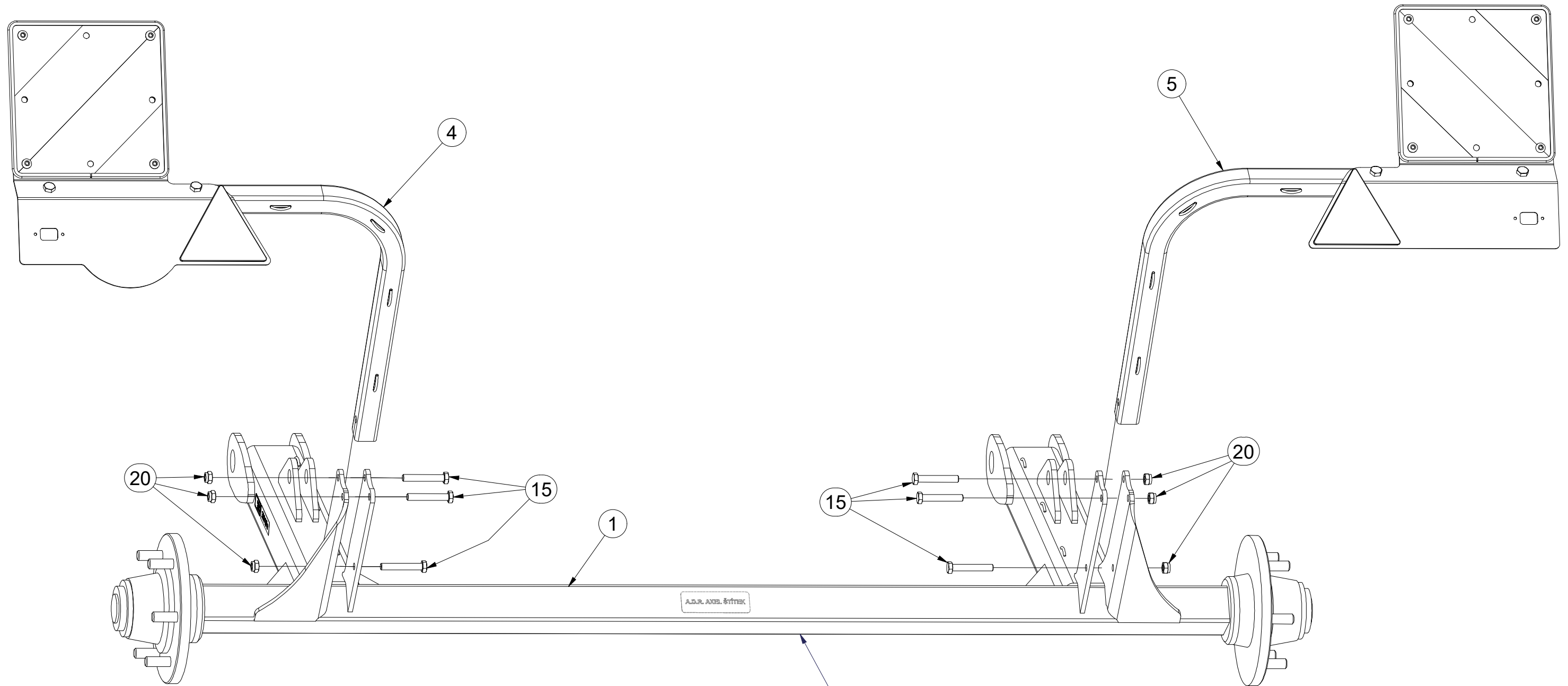

Pos.	Part Number	Pcs.
1	3012556	1
4	VZ00023833	1
5	VZ00023834	1
15	m12493	6
20	m04301	6

A70MR600N002

ⒸZ NÁPRAVA

ⒹACHSE

ⒻESSIEU

ⒸGB AXLE

ⒸRU OCB

ⒸPL OS



A70MR06

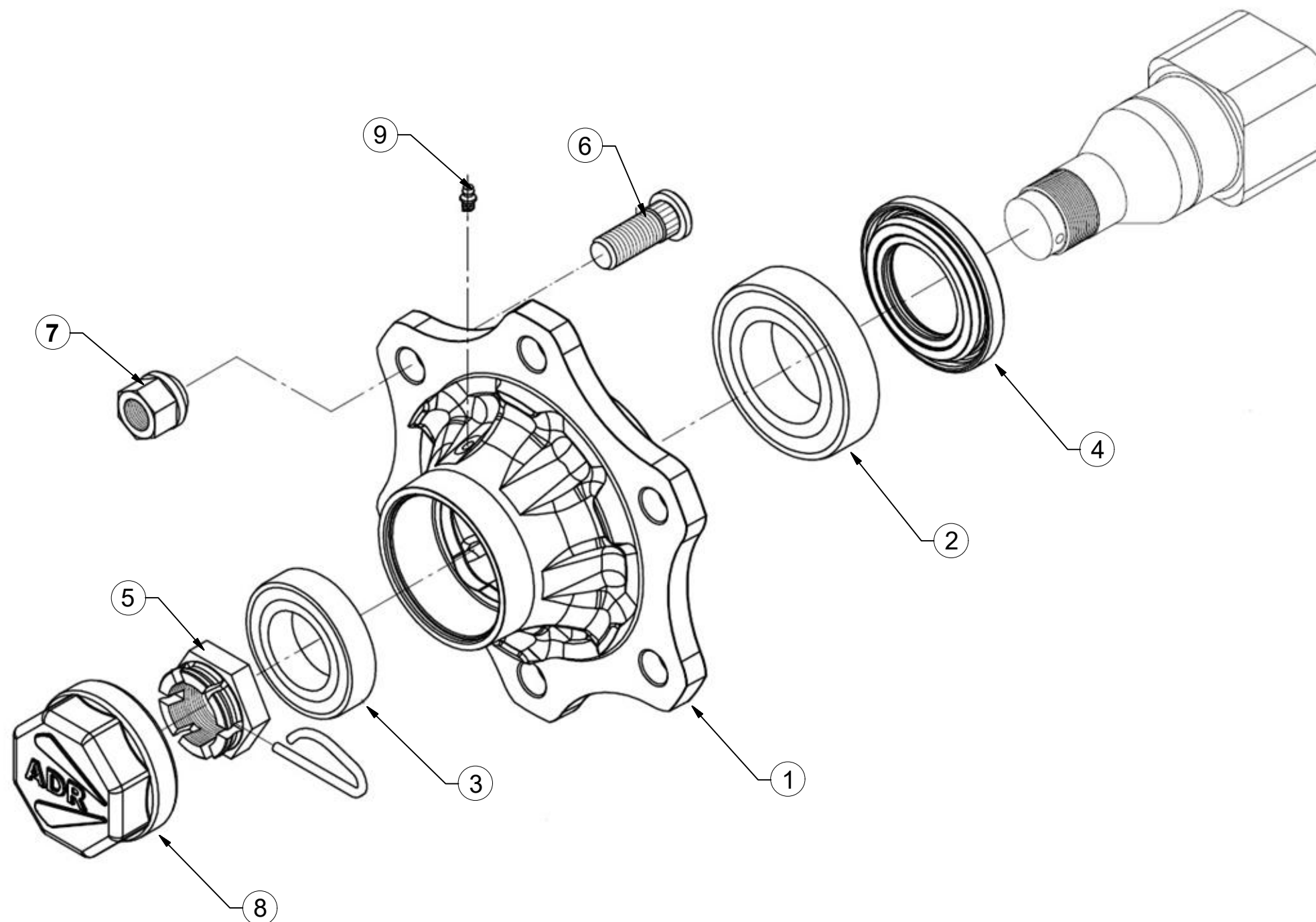

Pos	Part Number	Pcs.
1	m19667	2
2	m08194	2
3	m07152	2
4	m14924	2
5	m08169	2
6	m08148	12
7	m08163	12
8	m19668	2
9	m05698	2

(CZ) SADA HOMOLOGACE
 (D) HOMOLOGATIONSATZ
 (F) KIT DE HOMOLOGATION

(GB) SET OF HOMOLOGATION
 (RU) КОМПЛЕКТ УТВЕРЖДЕНИЯ
 (PL) ZESTAW HOMOLOGACJA



VZ00018587

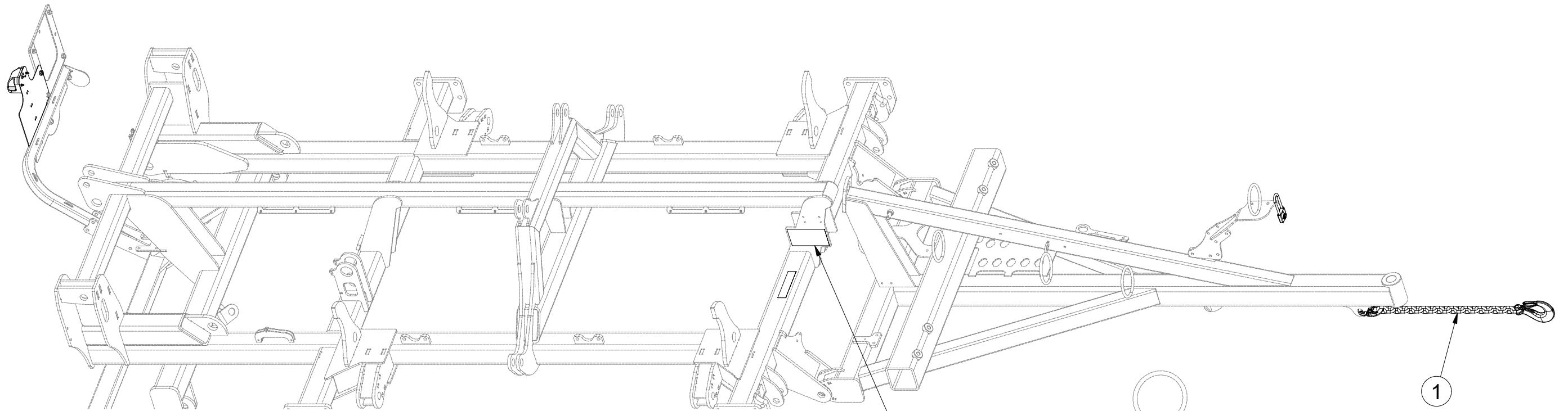

Pos.	Part Number	Pcs.
1	3012498	1
2	4025230	1
3	4025948	1

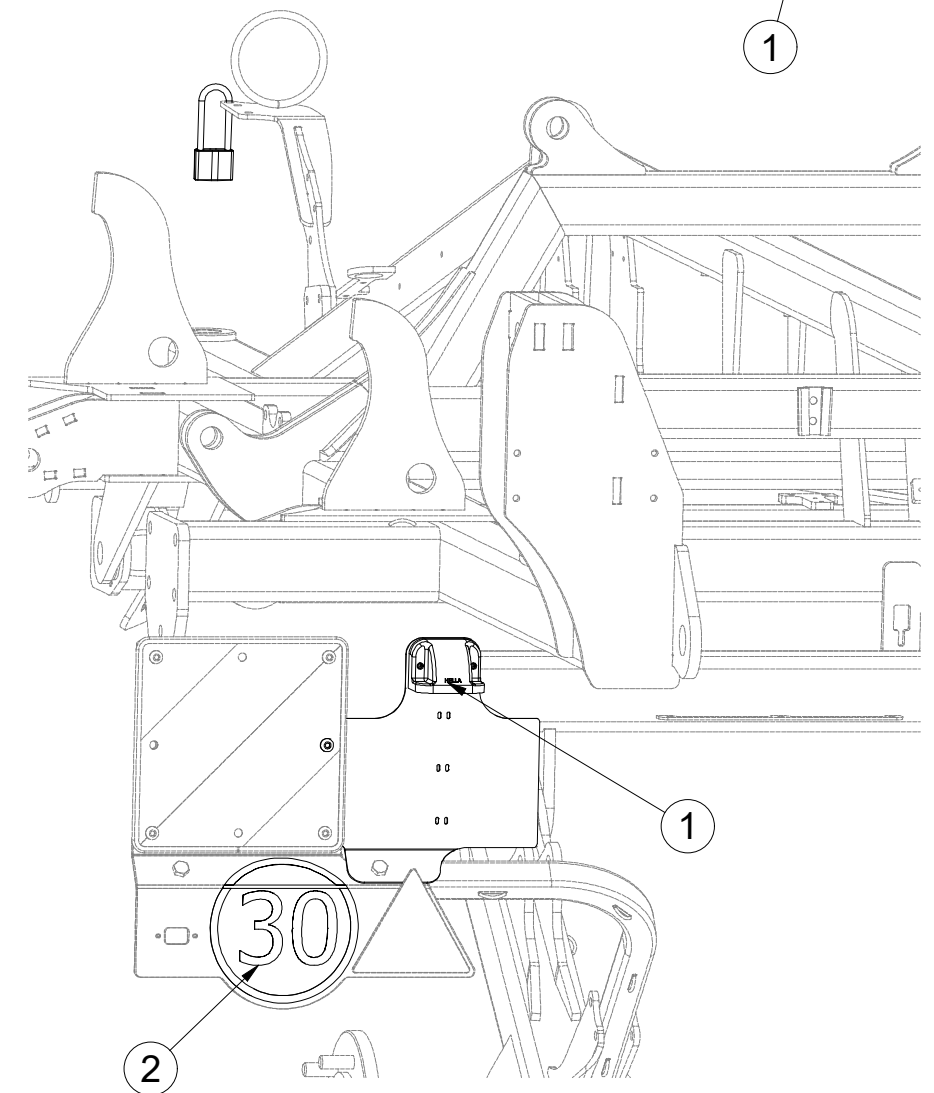

ⒸZ TERČ ZADNÍ LEVÝ - HOMOLOGACE

Ⓓ SCHILD, HINTERES, LINKES - HOMOLOGATION

Ⓕ CIBLE ARRIÈRE GAUCHE - HOMOLOGATION

3012498

ⒸB LEFT REAR DISC - HOMOLOGATION

ⒸU ЩИТОК ЗАДНИЙ ЛЕВЫЙ - УТВЕРЖДЕНИЯ

ⒸL TARCZA TYLNA LEWA - HOMOLOGACJA

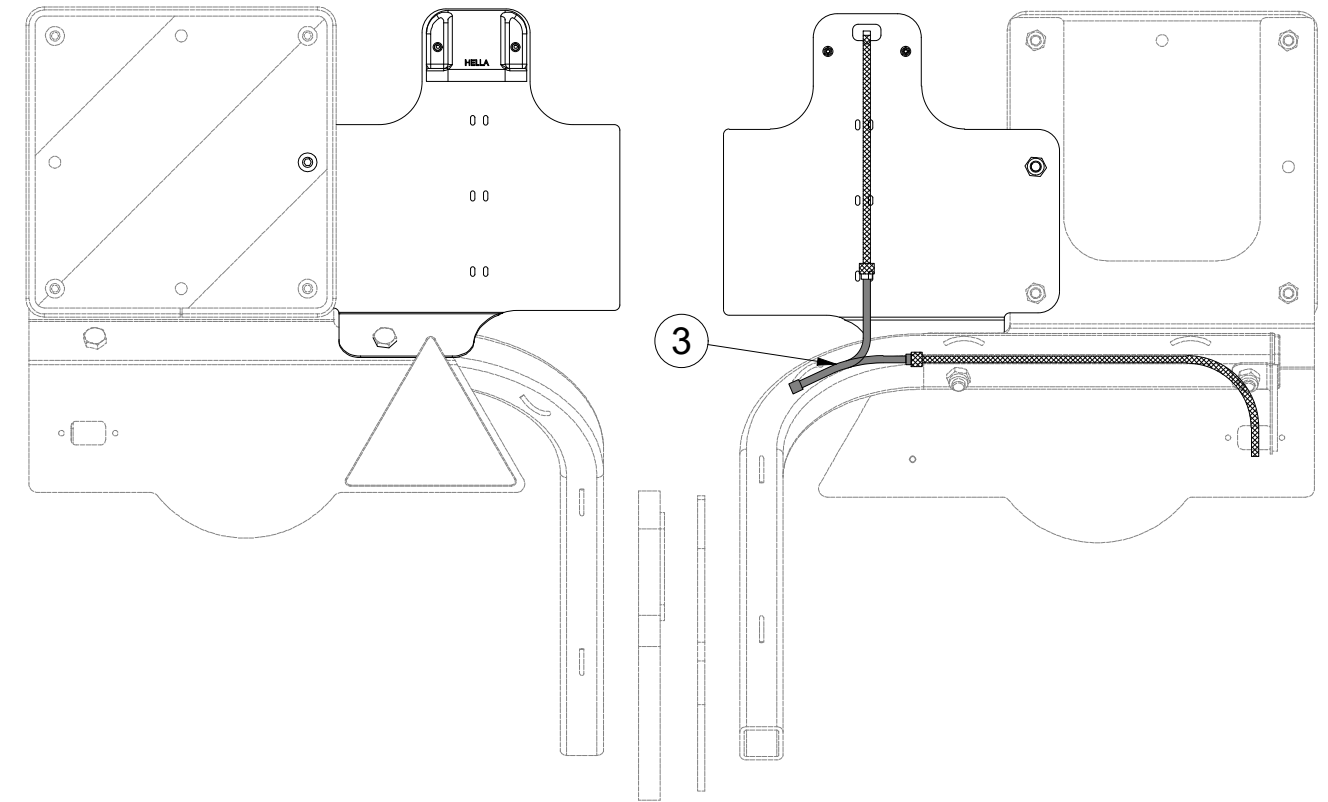
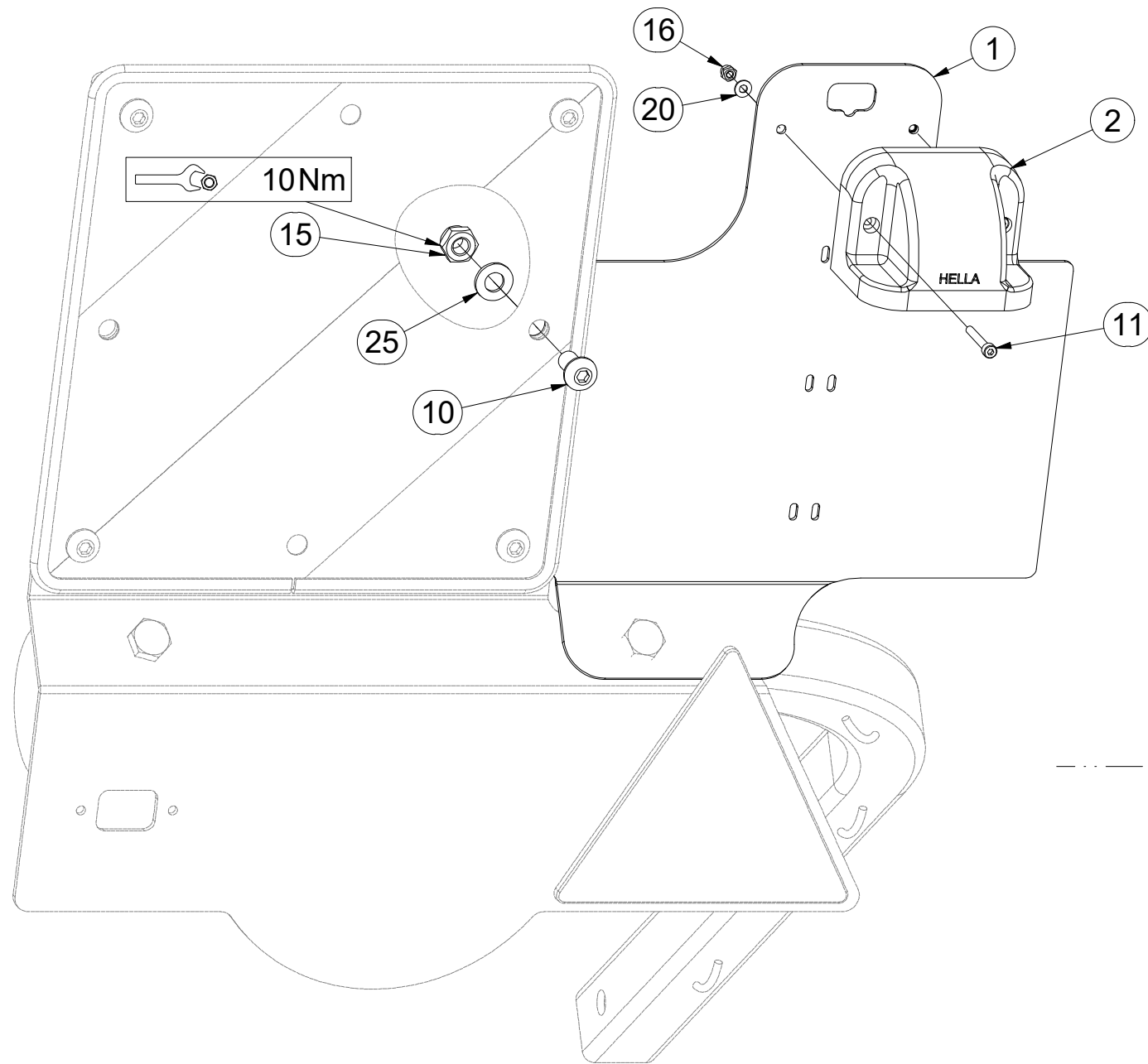

Pos.	Part Number	Pcs.	Pos.	Part Number	Pcs.
1	3012366	1	11	m16861	2
2	m18862	1	15	m03775	1
3	m18861	1	16	m05562	2
4	m18814	1	20	m05597	2
5	4025903	1	25	m01209	1
10	m16637	1			

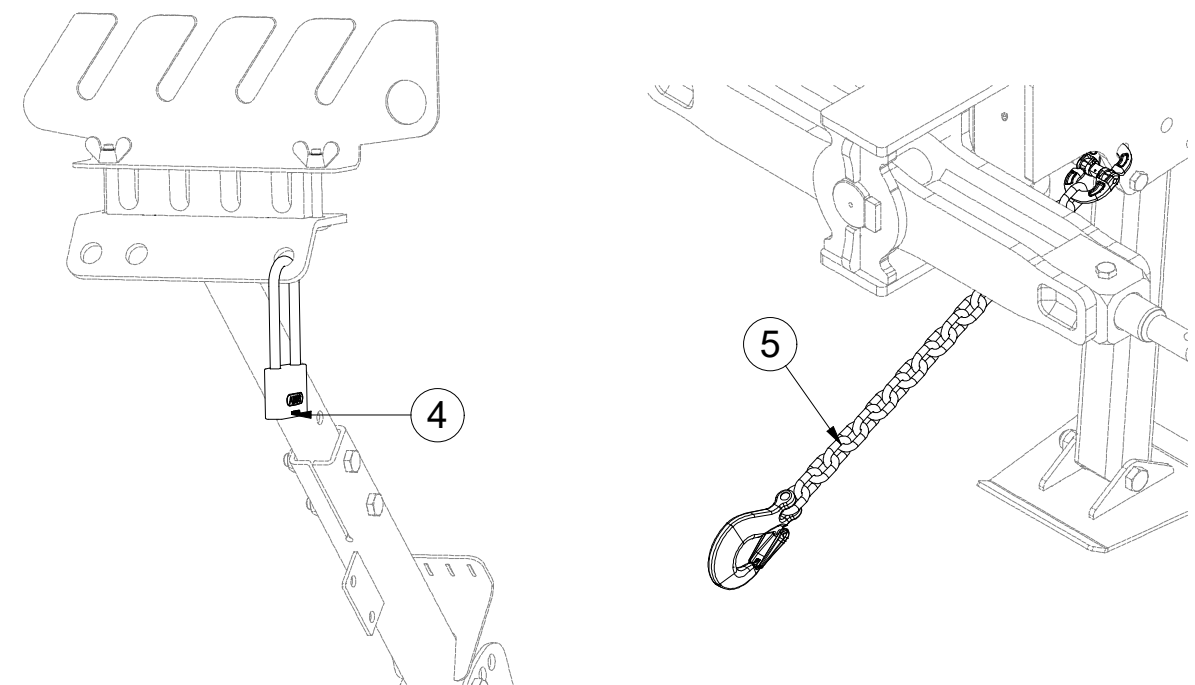

ⒸZ TERČ ZADNÍ LEVÝ

Ⓓ SCHILD, HINTERES, LINKES

Ⓕ CIBLE ARRIÈRE GAUCHE

VZ00023833

ⒼB LEFT REAR DISC

ⒺЩИТОК ЗАДНИЙ ЛЕВЫЙ

ⒽL TARCZA TYLNA LEWA

Farmet

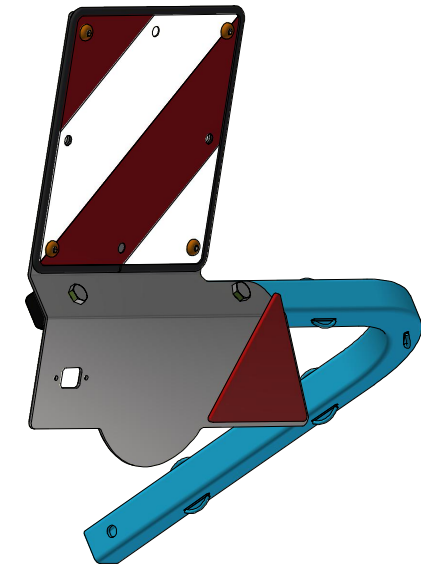
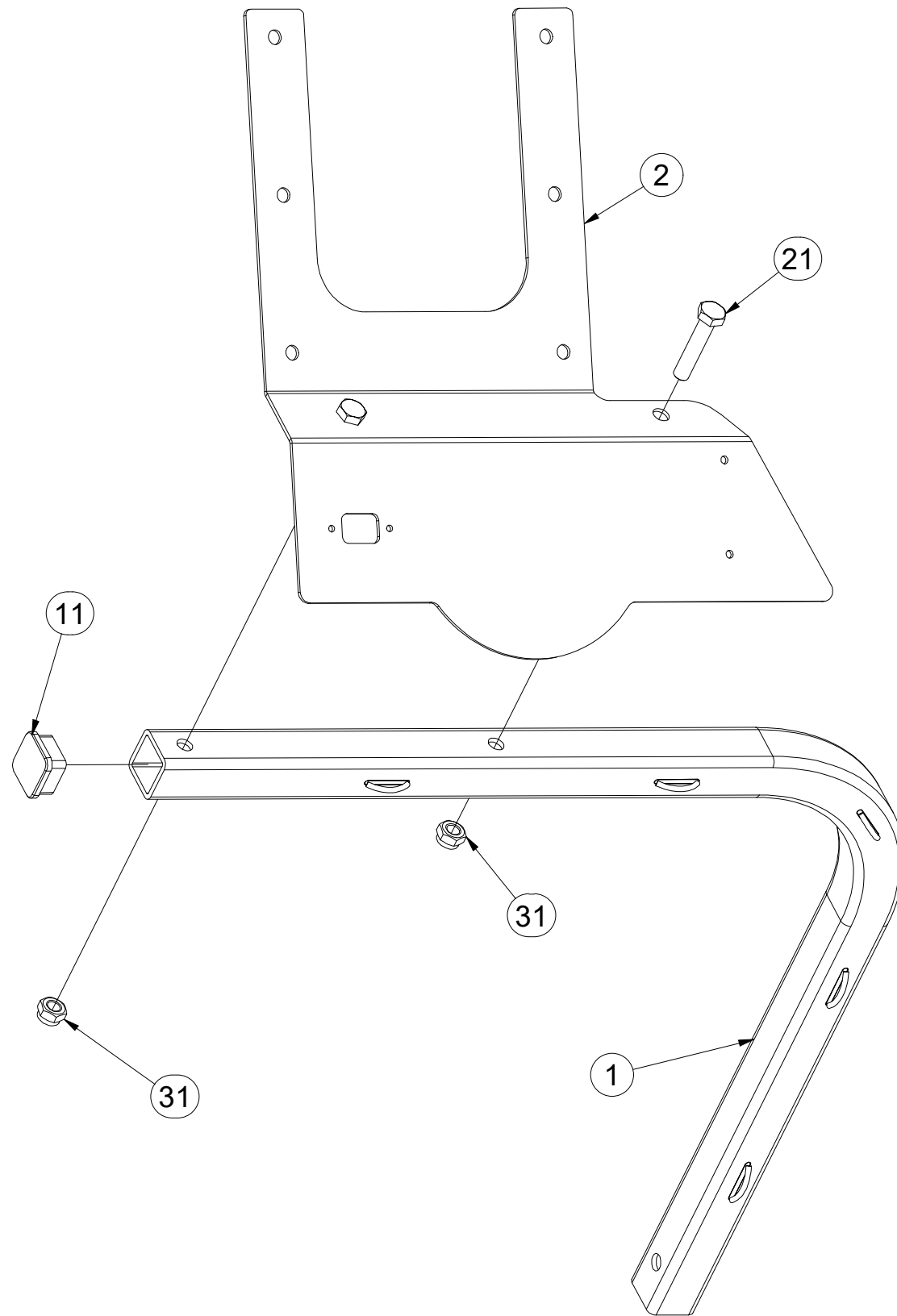

Pos.	Part Number	Pcs.
1	3012433	1
2	3012365	1
11	m12689	1
21	m01131	2
31	m04301	2

ⒸZ TERČ ZADNÍ LEVÝ

Ⓓ SCHILD, HINTERES, LINKES

Ⓕ CIBLE ARRIÈRE GAUCHE

ⒼB LEFT REAR DISC

ⒶU ЩИТОК ЗАДНИЙ ЛЕВЫЙ

ⒶL TARCZA TYLNA LEWA



VZ00023833

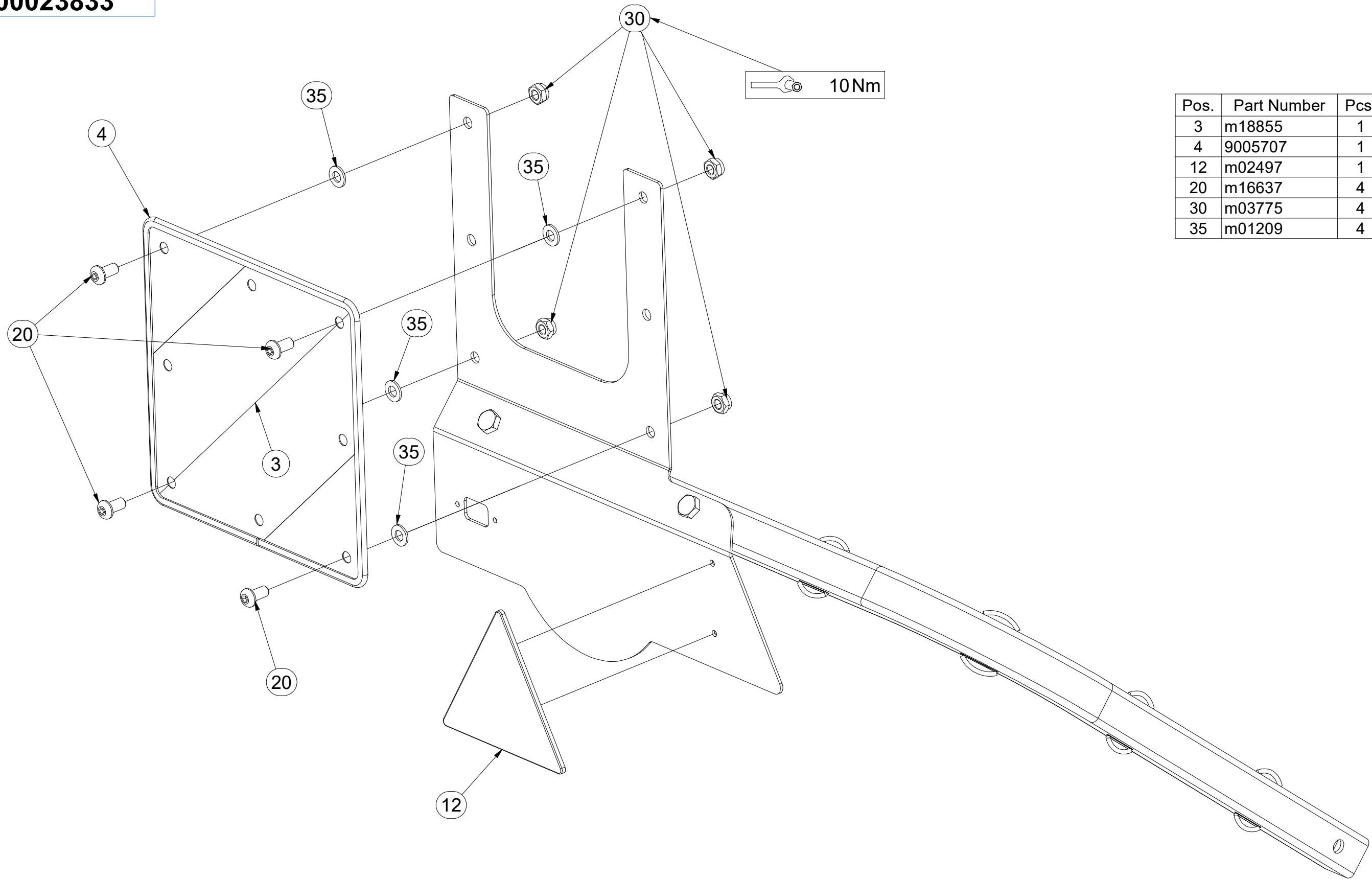

Pos.	Part Number	Pcs.
3	m18855	1
4	9005707	1
12	m02497	1
20	m16637	4
30	m03775	4
35	m01209	4

ⒸZ TERČ ZADNÍ PRAVÝ

Ⓓ SCHILD, HINTERES, RECHTES

Ⓕ CIBLE ARRIÈRE DROITE

VZ00023834

ⒼB RIGHT REAR DISC

ⒺЩИТОК ЗАДНИЙ ПРАВЫЙ

ⒽL TARCZA TYLNA PRAWA

Farmet

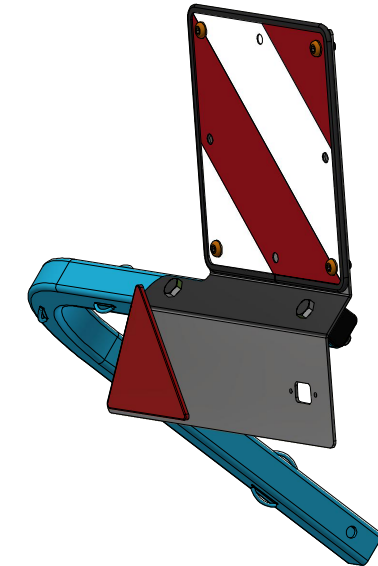
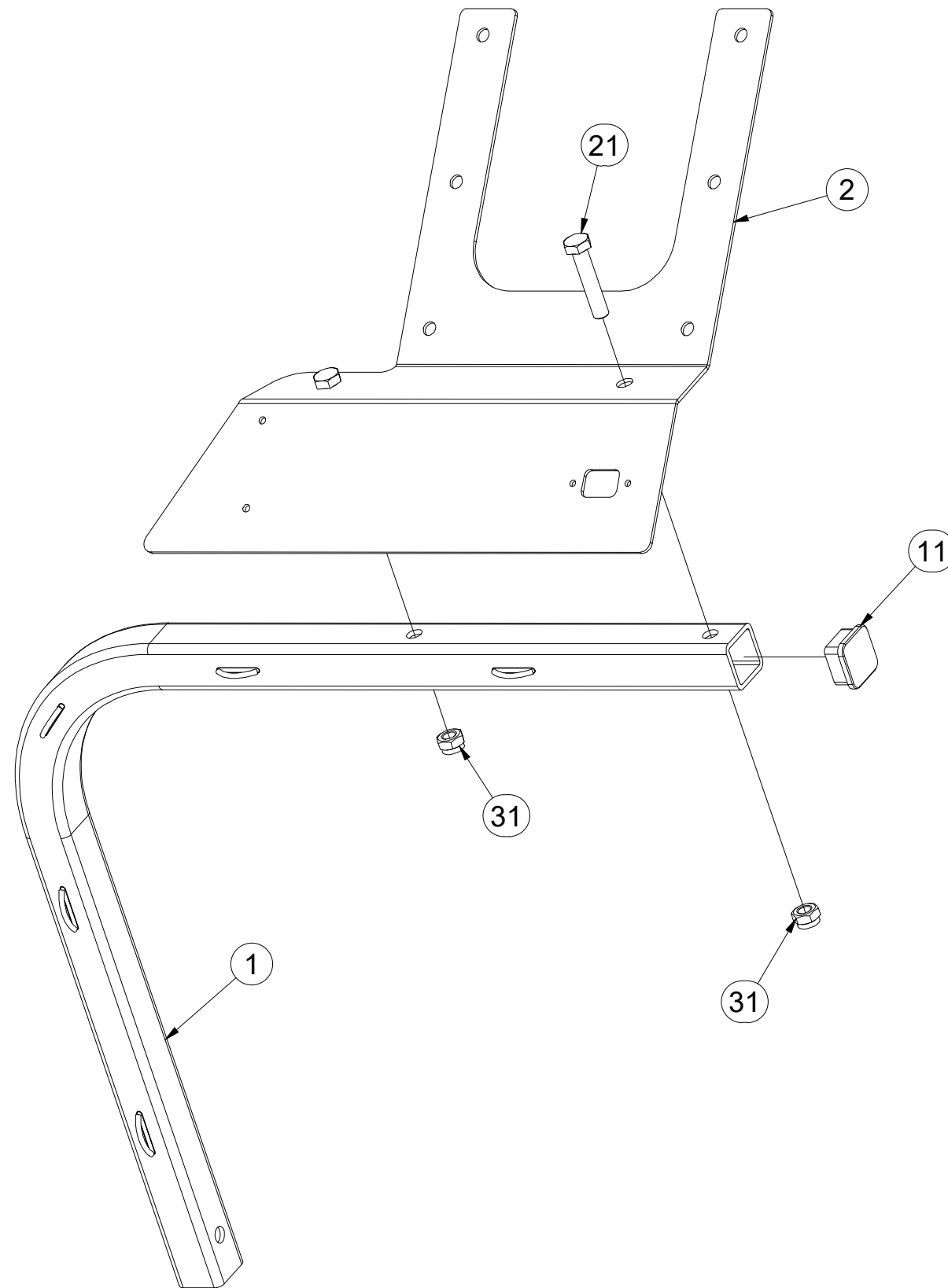

Pos.	Part Number	Pcs.
1	3012433	1
2	3012390	1
11	m12689	1
21	m01131	2
31	m04301	2

ⒸZ TERČ ZADNÍ PRAVÝ

Ⓓ SCHILD, HINTERES, RECHTES

Ⓕ CIBLE ARRIÈRE DROITE

ⒼB RIGHT REAR DISC

ⒶU ЩИТОК ЗАДНИЙ ПРАВЫЙ

ⒶL TARCZA TYLNA PRAWA



VZ00023834

Pos.	Part Number	Pcs.
3	m18855	1
4	9005707	1
12	m02497	1
20	m16637	4
30	m03775	4
35	m01209	4

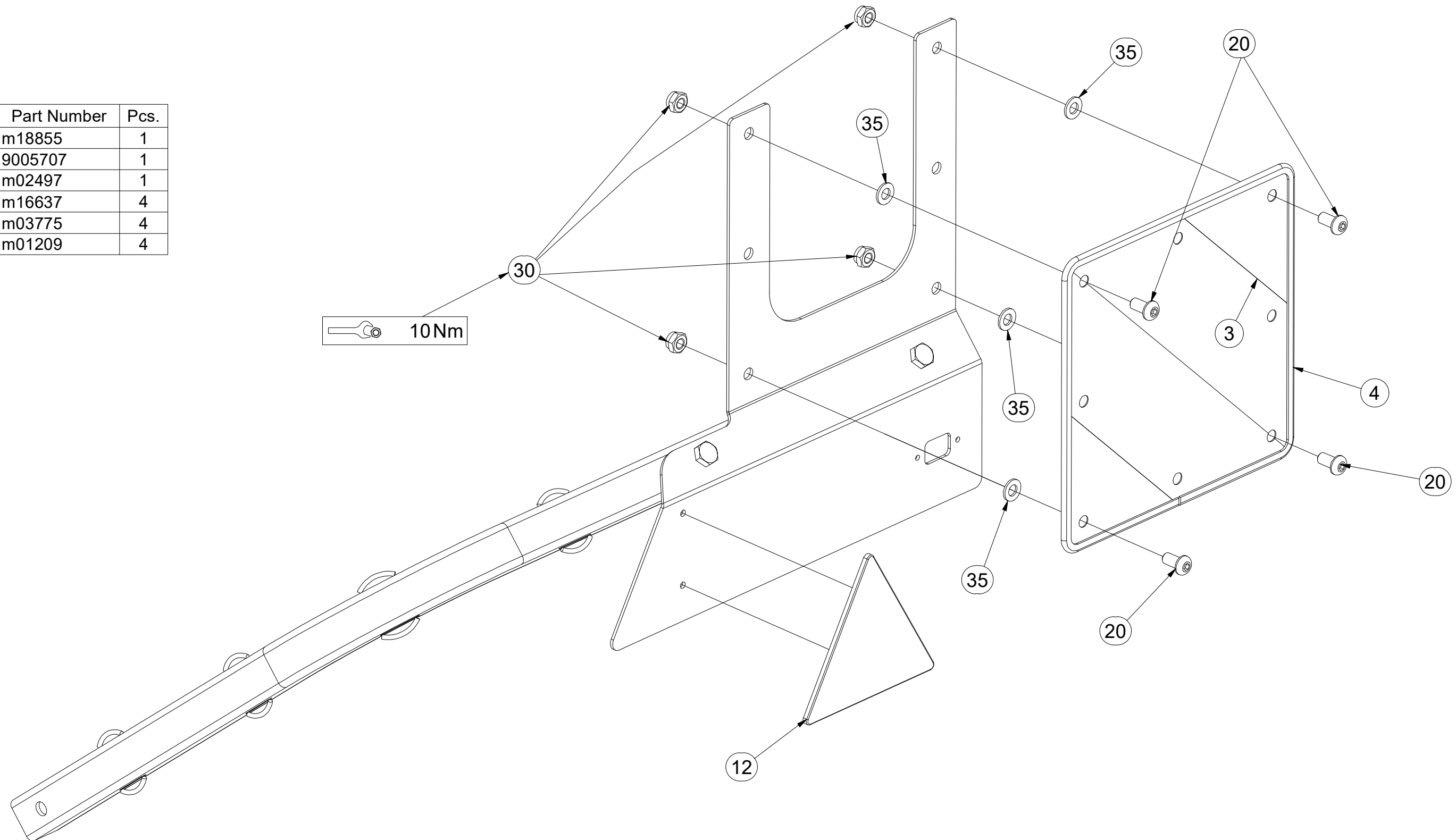

ⒸZ ŘETĚZ

Ⓓ KETTE

Ⓕ CHAÎNE

4025903

ⒼB CHAIN

ⒺU ЦЕПЬ

ⒺL ŁAŃCUCH

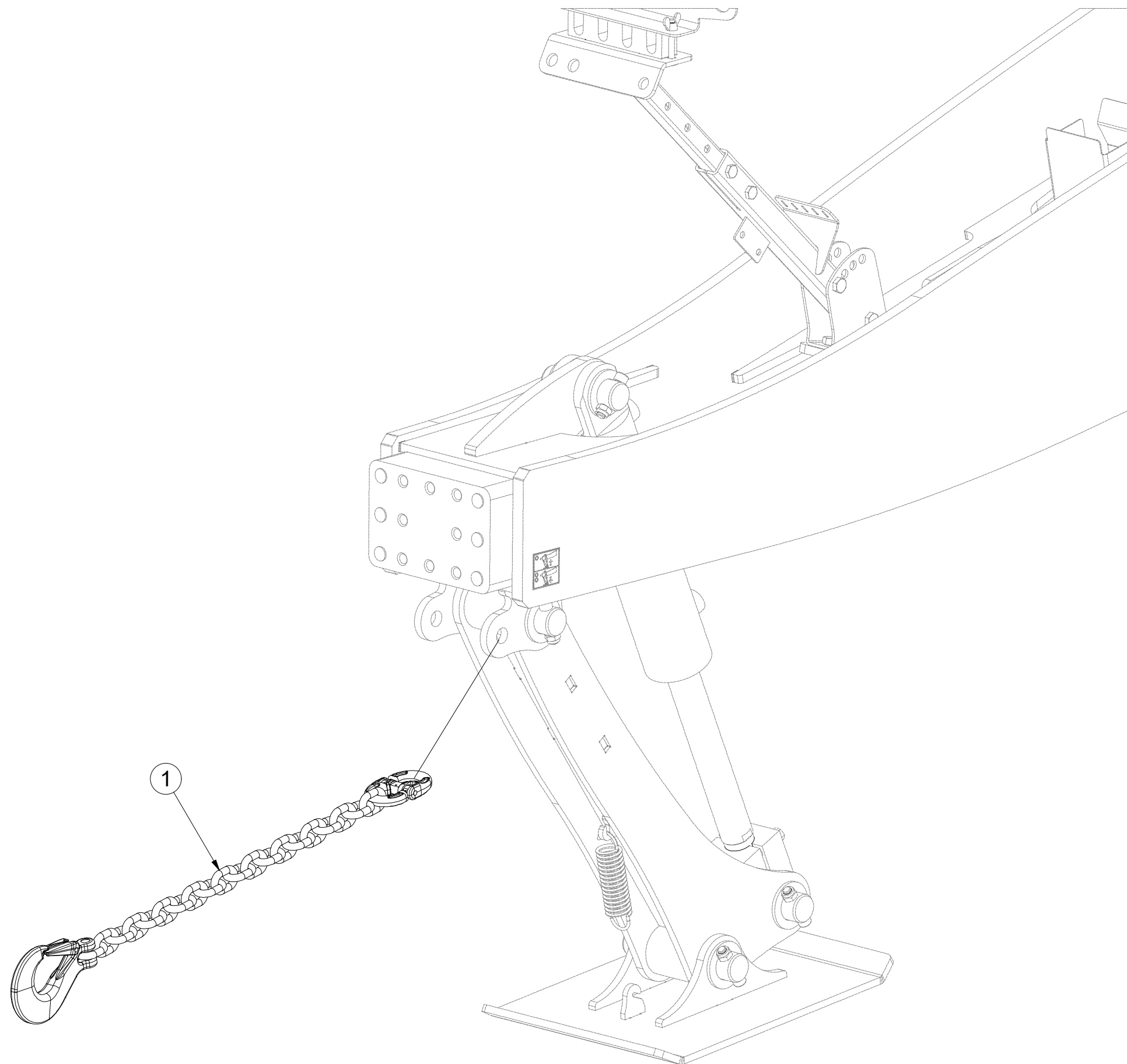

Pos.	Part Number	Pcs.
1	9005854	1

Ⓒ SAMOLEPKY STROJE

Ⓓ AUFKLEBER MASCHINEN

Ⓕ VOITURE MACHINES

Ⓖ STICKERS MACHINES

Ⓡ СТИКЕРЫ МАШИНЫ

Ⓟ NAKLEJKI MASZYNY



4025230

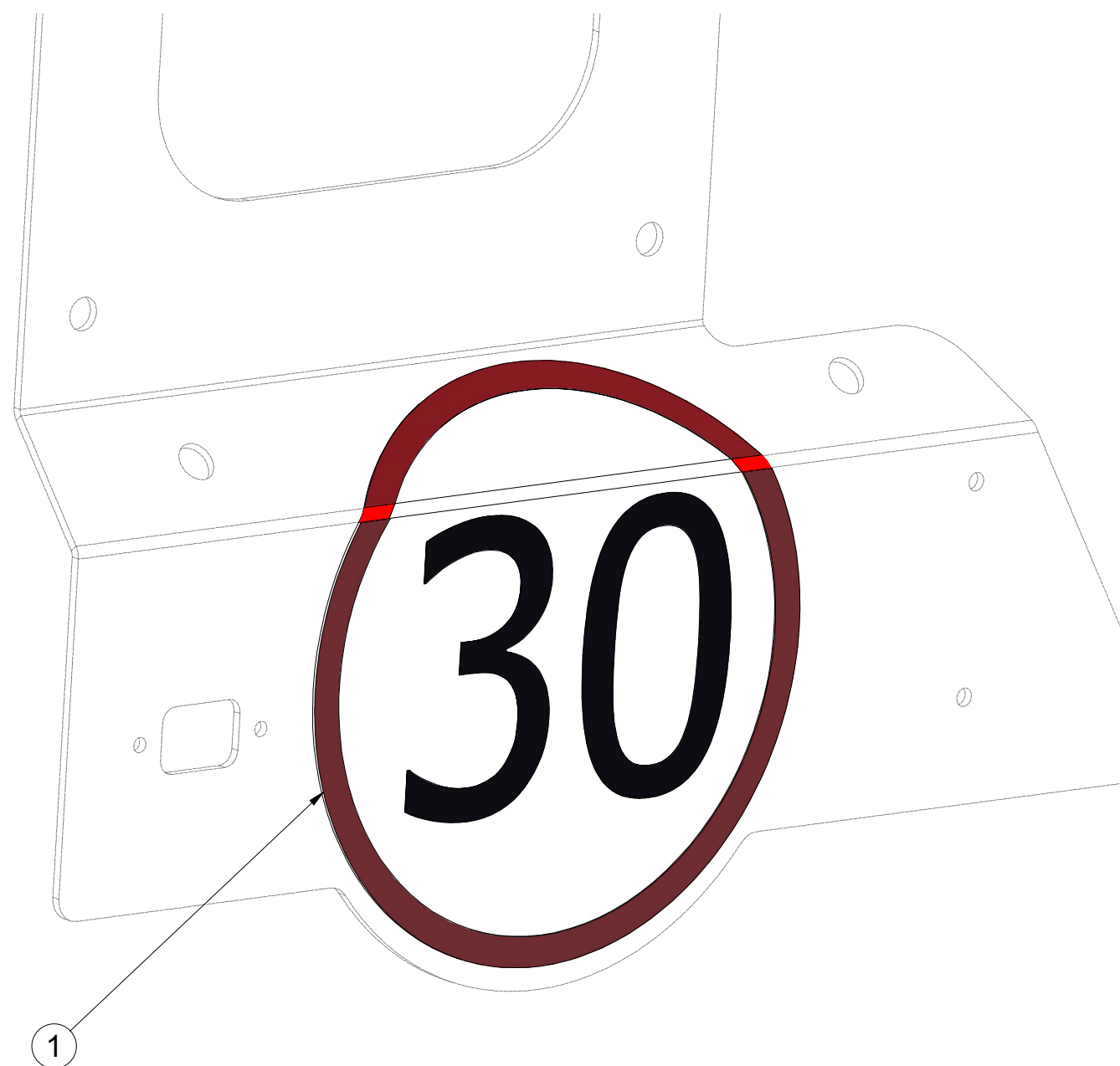

Pos.	Part Number	Pcs.
1	m19161	1

ⒸZ SOUPRAVA TĚSNIVA PÍSTNIC

Ⓓ KOLBENSTANGENDICHTUNGSMITTELSATZ

Ⓕ SET DE GARNITURE DES TIGES DE PISTON

ⒼB SEALING SET FOR PISTON RODS

ⒺU КОМПЛЕКТ ПРОКЛАДОК ЦИЛИНДРОВ

ⒼL ZESTAW USZCZELEK TRZPIENIA TŁOKA

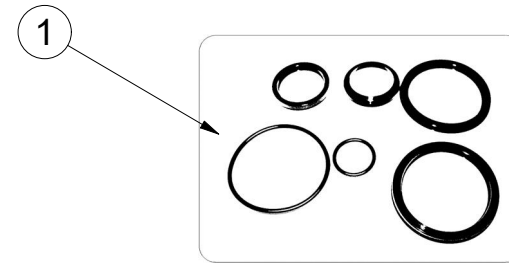
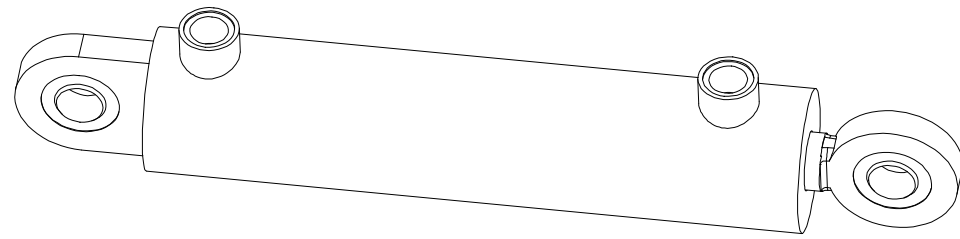

VZ00015266 - $\varnothing 63/\varnothing 32-250$		
Pos	Part number	Pcs
1	m05442	2

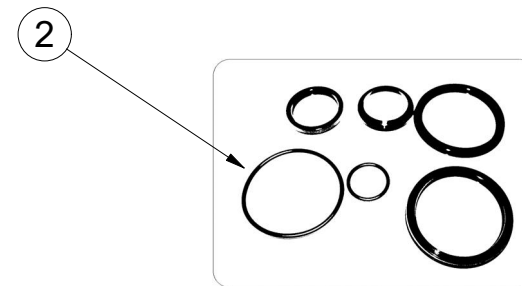
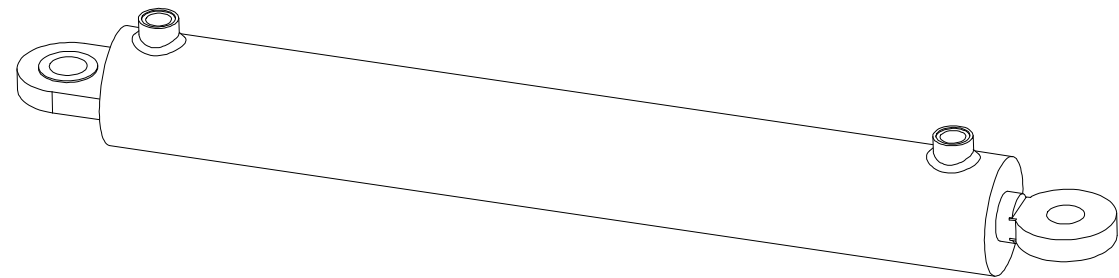

VZ00004545 - $\varnothing 80/\varnothing 40-630$		
Pos	Part number	Pcs
2	m20702	1

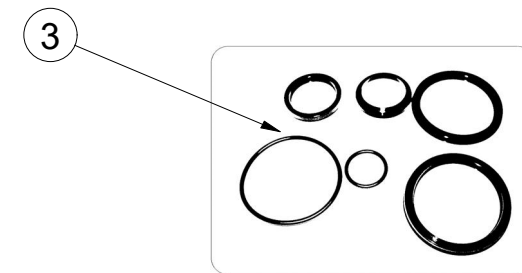
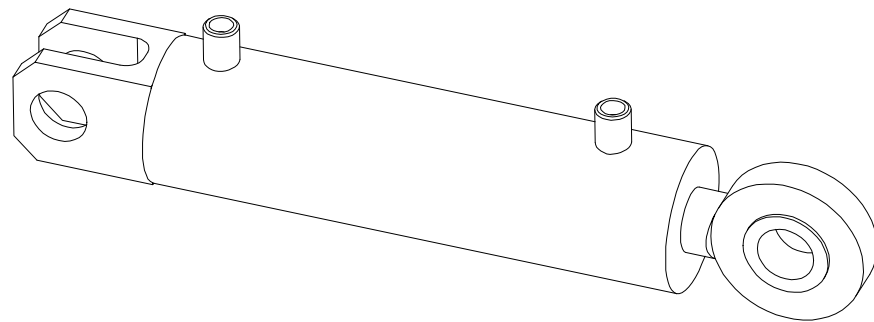

VZ00012974 - $\varnothing 40/\varnothing 22-100$		
Pos	Part number	Pcs
3	m20706	4

Ⓒ SVĚTELNÁ SADA

Ⓓ LEUCHTENSATZ

Ⓕ KIT LUMINEUX

Ⓖ LIGHTING SET

Ⓡ ОСВЕТИТЕЛЬНЫЙ КОМПЛЕКТ

Ⓟ ZESTAW OŚWIETLENIA



3012562

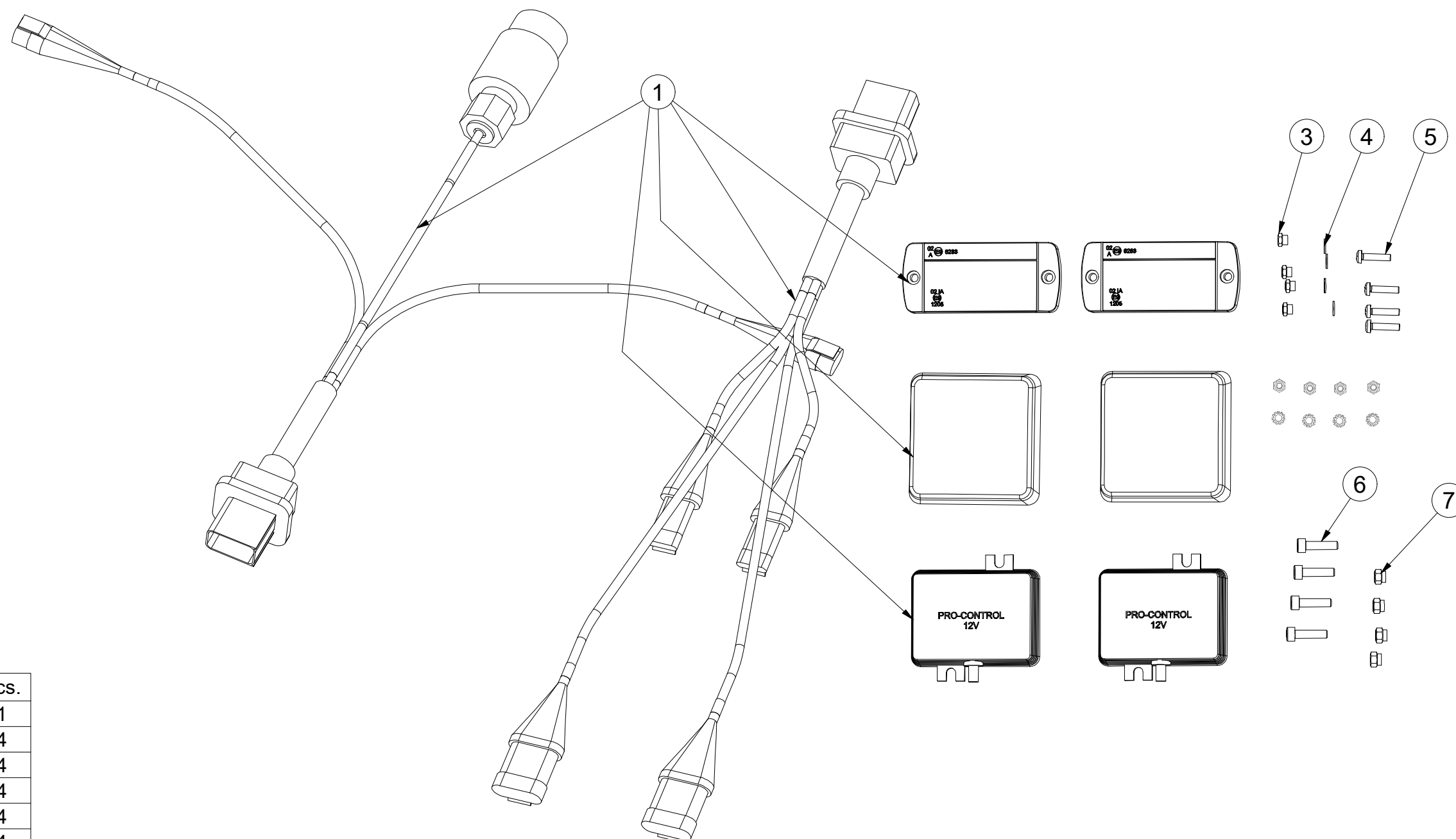

Pos.	Part Number	Pcs.
1	m19089	1
3	m05562	4
4	m05597	4
5	m15790	4
6	m10591	4
7	m06236	4
10	m05566	50

Ⓒ SVĚTELNÁ SADA

Ⓓ LEUCHTENSATZ

Ⓕ KIT LUMINEUX

3012562

Ⓒ LIGHTING SET

Ⓔ ОСВЕТИТЕЛЬНЫЙ КОМПЛЕКТ

Ⓖ ZESTAW OŚWIETLENIA

Farmet

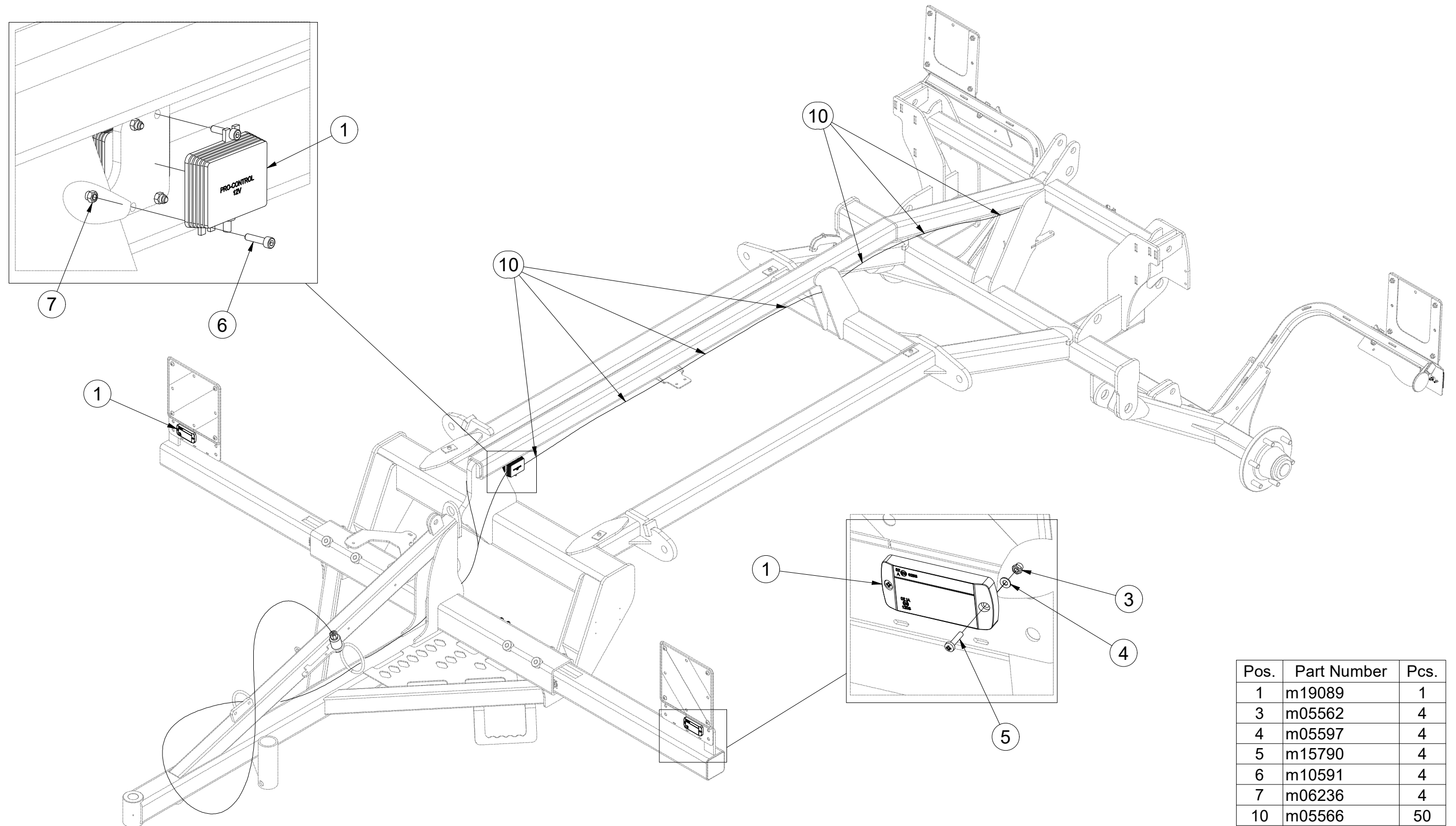

Pos.	Part Number	Pcs.
1	m19089	1
3	m05562	4
4	m05597	4
5	m15790	4
6	m10591	4
7	m06236	4
10	m05566	50

Ⓒ SVĚTELNÁ SADA

Ⓓ LEUCHTENSATZ

Ⓕ KIT LUMINEUX

Ⓖ LIGHTING SET

Ⓡ ОСВЕТИТЕЛЬНЫЙ КОМПЛЕКТ

Ⓟ ZESTAW OŚWIETLENIA

Farmet

3012562

Pos.	Part Number	Pcs.
1	m19089	1
3	m05562	4
10	m05566	50

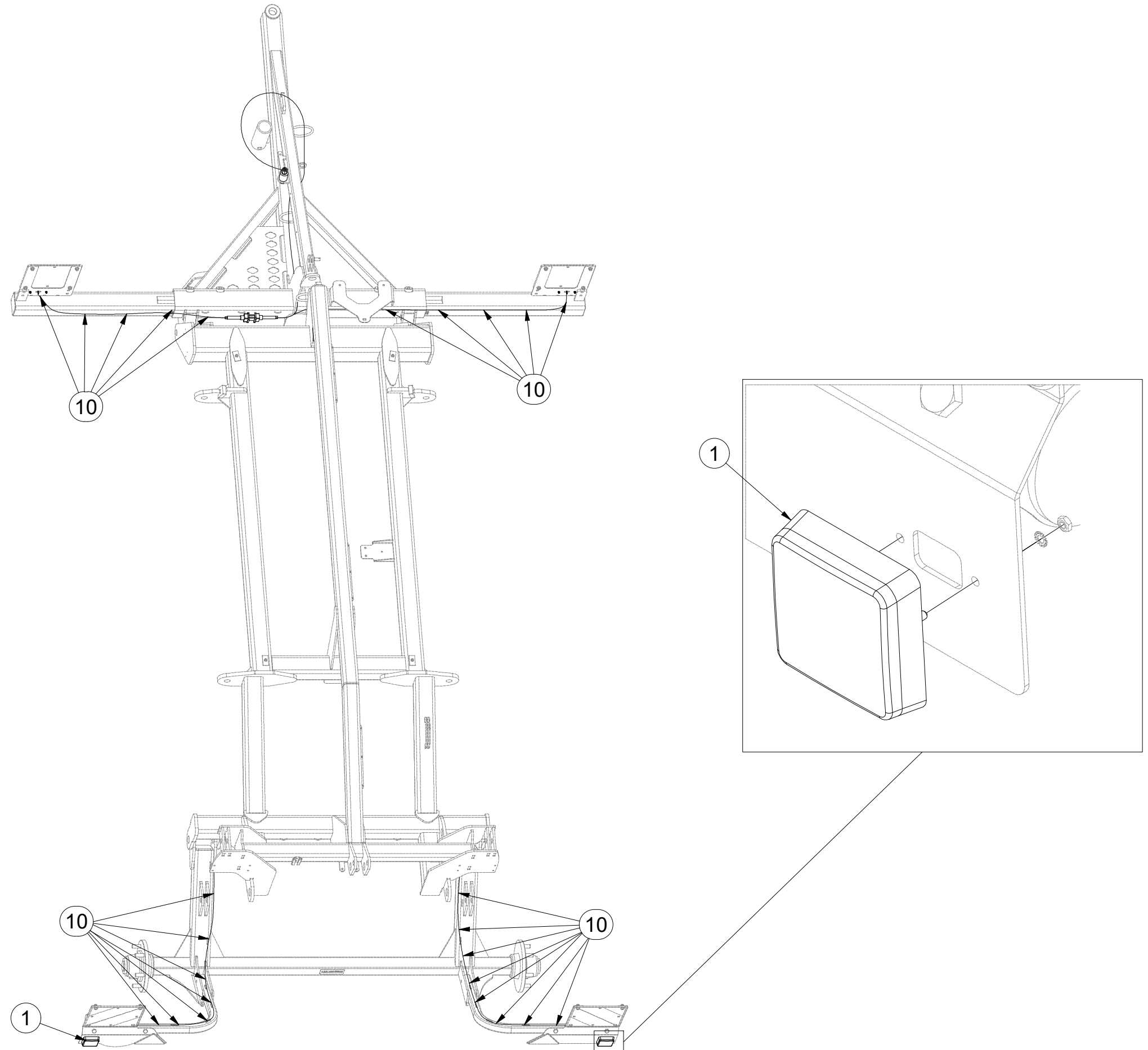

Ⓒ SVĚTELNÁ SADA

Ⓓ LEUCHTENSATZ

Ⓕ KIT LUMINEUX

Ⓖ LIGHTING SET

Ⓡ ОСВЕТИТЕЛЬНЫЙ КОМПЛЕКТ

Ⓟ ZESTAW OŚWIETLENIA



m19089

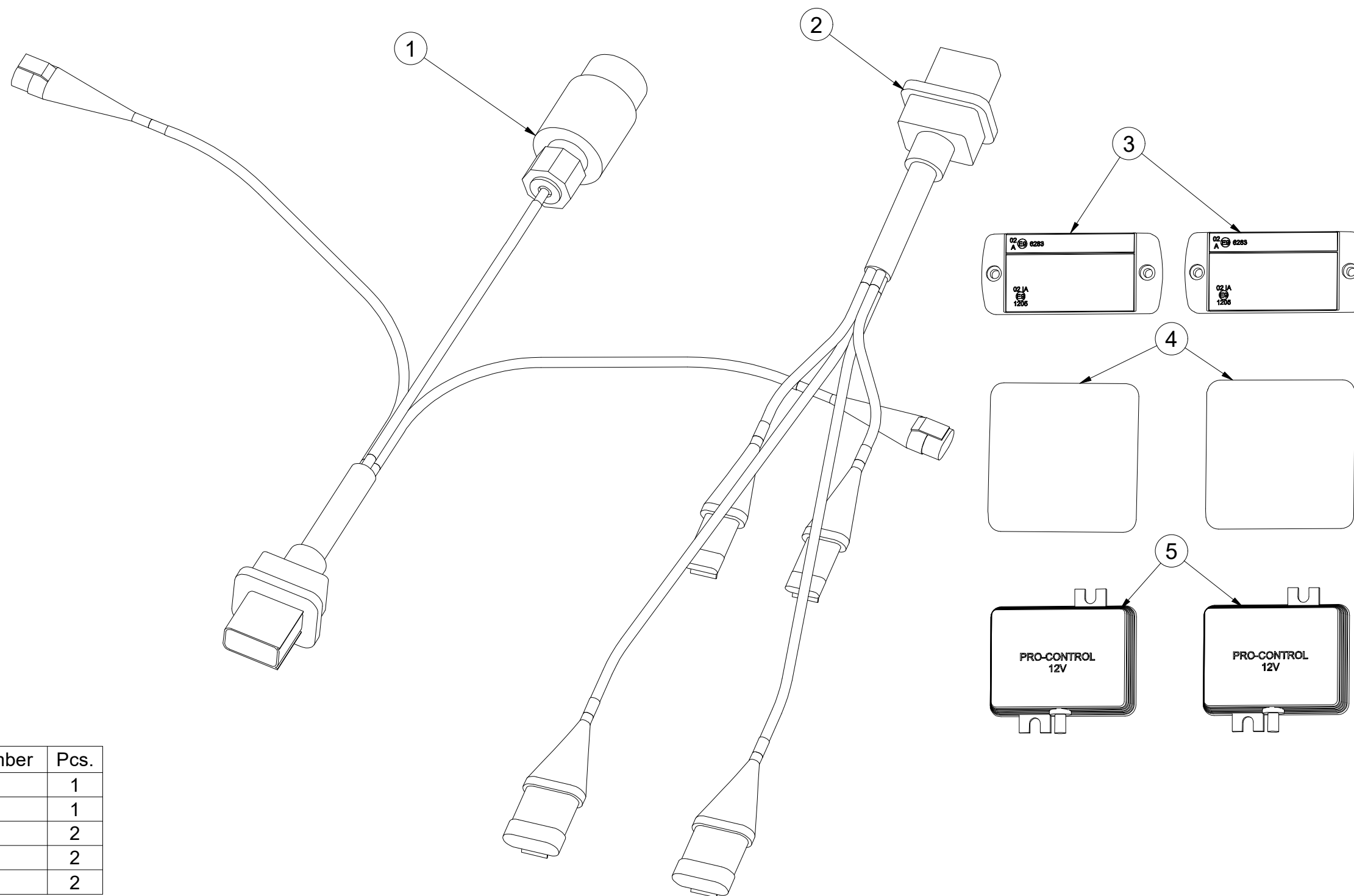

Pos.	Part Number	Pcs.
1	m14779	1
2	m14778	1
3	m14776	2
4	m19044	2
5	m14777	2

- Ⓒ UTAHOVACÍ MOMENTY ŠROUBŮ
 Ⓓ ANZUGMOMENTE VON SCHRAUBEN
 Ⓕ COUPLES DE SERRAGE DES VIS

- Ⓒ SCREW TIGHTENING TORQUE
 Ⓓ МОМЕНТЫ ЗАЖАТИЯ БОЛТОВ
 Ⓕ MOMENTY DOKRĘCANIA ŚRUB



P		5.8	8.8	10.9	12.9	Z	
D	R	Mu	Mu	Mu	Mu	DIN 7991	ISO 10642
mm	mm	Nm	Nm	Nm	Nm	Nm	Nm
M6	1	6	9	13	15	7,2	7,9
M8	1,25	14	22	32	38	17	19
M10	1,5	29	44	64	75	35	38
M12	1,75	49	76	111	130	58	65
M14	2	79	120	176	206	93	100
M16	2	123	188	276	323	144	158
M18	2,5	169	257	378	443	-	220
M20	2,5	239	365	536	628	-	310
M22	2,5	329	529	738	864	-	420
M24	3	413	629	924	1082	-	530
M27	3	613	934	1372	1606	-	-
M30	3,5	832	1267	1862	2179	-	-
M33	3,5	1130	1723	2530	2961	-	-
M36	4	1451	2210	3246	3799	-	-
M39	4	1885	2872	4217	4936	-	-
M42	4,5	2322	3538	5196	6080	-	-
M45	4,5	2909	4433	6511	7619	-	-
M48	5	3513	535	7862	9200	-	-
M52	5	4524	6895	10123	11849	-	-
M56	5,5	5636	8589	12614	14761	-	-

- Mu - Ⓒ UTAHOVACÍ MOMENT
 Ⓓ ANZUGMOMENTE
 Ⓕ COUPLE DE SERRAGE
 Ⓒ TIGHTENING TORQUE
 Ⓓ МОМЕНТ ЗАЖАТИЯ
 Ⓕ MOMENT DOKRĘCANIA
- D - Ⓒ JMENOVITÝ PRŮMĚR
 Ⓓ NENNDURCHMESSER
 Ⓕ DIAMETRE NOMINAL
 Ⓒ NOMINAL DIAMETER
 Ⓓ НОМИНАЛЬНЫЙ ДИАМЕТР
 Ⓕ ŚREDNICA NOMINALNA
- R - Ⓒ ROZTEČ ZÁVITU - STOUPÁNÍ
 Ⓓ GEWINDESTEIFUNG
 Ⓕ PAS DE FILET - PAS
 Ⓒ SCREW PITCH – LEAD
 Ⓓ ШАГ РЕЗЬБЫ
 Ⓕ ROZSTAW GWINTU - SKOKI
- P - Ⓒ PEVNOST
 Ⓓ FESTIGKEIT
 Ⓕ RÉSISTANCE
 Ⓒ STRENGTH
 Ⓓ ПРОЧНОСТЬ
 Ⓕ WYTRZYMA OŚĆ
- Z - Ⓒ ZÁPUSTNÉ ŠROUBY
 Ⓓ SENKKOPFSCHRAUBEN
 Ⓕ VIS A TETE FRAISEE
 Ⓒ COUNTERSUNK SCREWS
 Ⓓ БОЛТЫ С УТОПЛЕННОЙ ГОЛОВКОЙ
 Ⓕ ŚRUBY Z ŁBEM STOŻKOWYM PŁASKIM

- Ⓒ Hodnoty momentů jsou poníženy o -10% oproti tabulkovým hodnotám. Šroubové spoje utahujte dle vyznačeného utahovacího momentu v dokumentaci. Pokud není utahovací moment v dokumentaci vyznačen, utahujte dle obecné tabulky. Pokud je v dokumentaci definován spoj šroubu a matice o různých pevnostech, vždy utahujte na moment komponenty nižší.
- Ⓓ Die Werte der Anzugsmomente sind um 10 % gegenüber den Tabellenwerten verringert. Ziehen Sie die Schraubverbindungen gemäß dem in der Dokumentation festgeschriebenen Anzugsmoment an. Sofern das Anzugsmoment nicht in der Dokumentation aufgeführt ist, ziehen Sie sie gemäß der allgemeinen Tabelle an. Wenn in der Dokumentation eine Verbindung von Schraube und Mutter mit verschiedene Festigkeiten definiert ist, wird immer mit dem Moment des Bauteils mit der geringeren Festigkeit angezogen.
- Ⓕ Les valeurs des couples de serrage sont baissées de 10% par rapport aux valeurs de tableau. Serrez les raccords à vis selon le couple de serrage indiqué dans les documents. Si le couple de serrage n'est pas indiqué dans les documents, serrez selon le tableau général. Si les documents définissent un assemblage par boulon de diverses résistances, serrez toujours au moment de la composante avec résistance inférieure.
- Ⓒ The torque values are reduced by 10% compared to the table values. Tighten the screw joints according to the tightening torque stated in the documentation. If the tightening torque is not stated in the documentation, tighten according to the general table. If there is a joint with a screw and a nut at different strengths in the documentation, always tighten to the torque of the component with lower strength.
- Ⓓ Значения моментов затяжки уменьшены на 10% по сравнению с данными в таблице. Резьбовые соединения зажимайте с установленным в документации моментом зажатия. Если в документации не указан момент зажатия, то зажимайте по действующей в общем таблице. Если в документации установлено соединение из болта и гайки различной прочности, всегда зажимайте с моментом для компонента с меньшей прочностью.
- Ⓕ Wartości momentów dokręcania są obniżone o 10% w stosunku do wartości z tabeli. Połączenia śrubowe należy dokręcać zgodnie z momentem obrotowym w dokumentacji. Jeśli w dokumentacji nie ma podanego momentu obrotowego, należy dokręcać zgodnie z ogólną tabelą. Jeśli w dokumentacji zdefiniowane jest połączenie ze śrubą nakrętką różnych wytrzymałościach, zawsze należy dokręcać zachowując moment dokręcania komponentu z niższą wytrzymałością.

- Ⓒ UTAHOVACÍ MOMENTY ŠROUBŮ
 Ⓓ ANZUGMOMENTE VON SCHRAUBEN
 Ⓕ COUPLES DE SERRAGE DES VIS

- Ⓖ SCREW TIGHTENING TORQUE
 Ⓡ MOMENTЫ ЗАЖАТИЯ БОЛТОВ
 Ⓟ MOMENTY DOKRĘCANIA ŚRUB



- Ⓒ **OBECNÝ PŘEDPIS UTAHOVÁNÍ ZAJIŠTĚNÍ ČEPOVÝCH SPOJŮ:**
 Ⓓ **ALLGEMEINE VORSCHRIFT FÜR DAS ANZIEHEN VON BOLZENVERBINDUNGEN:**
 Ⓕ **CONSIGNE GENERALE POUR LE SERRAGE DES ARTICULATIONS CYLINDRIQUES:**
 Ⓖ **GENERAL INSTRUCTION FOR TIGHTENING THE SECURING OF PIN JOINTS:**
 Ⓡ **ОБЩЕЕ ОПИСАНИЕ ЗАЖАТИЯ ПРЕДОХРАНЕНИЯ СОЕДИНЕНИЙ ПАЛЬЦАМИ:**
 Ⓟ **OGÓLNE ZASADY DOKRĘCANIA ZABEZPIECZENIA POŁĄCZEŃ CZOPEM:**



X

M8, M10, M12

M14

M

09-15Nm

15-25Nm

- X - Ⓒ ROZMĚR ŠROUBU
 Ⓓ SCHRAUBENGRÖSSE
 Ⓕ DIMENSIONS DE LA VIS

- Ⓖ BOLT DIMENSION
 Ⓡ РАЗМЕР БОЛТА
 Ⓟ ROZMIAR ŚRUBY

- M - Ⓒ ORIENTAČNÍ MOMENT
 Ⓓ ANZUGSMOMENT
 Ⓕ COUPLE D'ORIENTATION

- Ⓖ ORIENTATION TORQUE
 Ⓡ ОРИЕНТАЦИОННЫЙ МОМЕНТ
 Ⓟ ORIENTACYJNY MOMENT

- Ⓒ Tyto spoje není nutné ověřovat kontrolou momentovým klíčem = stačí vizuálně kontrolovat sešroubování.
 Ⓓ Diese Verbindungen müssen nicht mit einem Drehmomentschlüssel überprüft werden = es genügt, die Verschraubung visuell zu kontrollieren.
 Ⓕ Il n'est pas nécessaire de contrôler le serrage à l'aide d'une clé dynamométrique = un contrôle visuel de l'assemblage suffit.
 Ⓖ These joints do not have to be verified by checking with a torque wrench = visual inspection of bolting is sufficient.
 Ⓡ Эти соединения не нужно контролировать динамометрическим ключом = достаточно визуально проверять прикручивание.
 Ⓟ Nie trzeba sprawdzać tych połączeń kluczem dynamometrycznym = wystarczy wizualnie skontrolować dokręcenie.