

The effective technology

Farmet®

ⒸZ KATALOG NÁHRADNÍCH DÍLŮ ⒸB CATALOGUE OF SPARE PARTS ⒸD ERSATZTEILLISTE
ⒸRU КАТАЛОГ ЗАПАСНЫХ ЧАСТЕЙ ⒸF CATALOGUE DES PIÈCES DE RECHANGE ⒸPL KATALOG CZĘŚCI ZAMIENNYCH

DIGGER 3 N

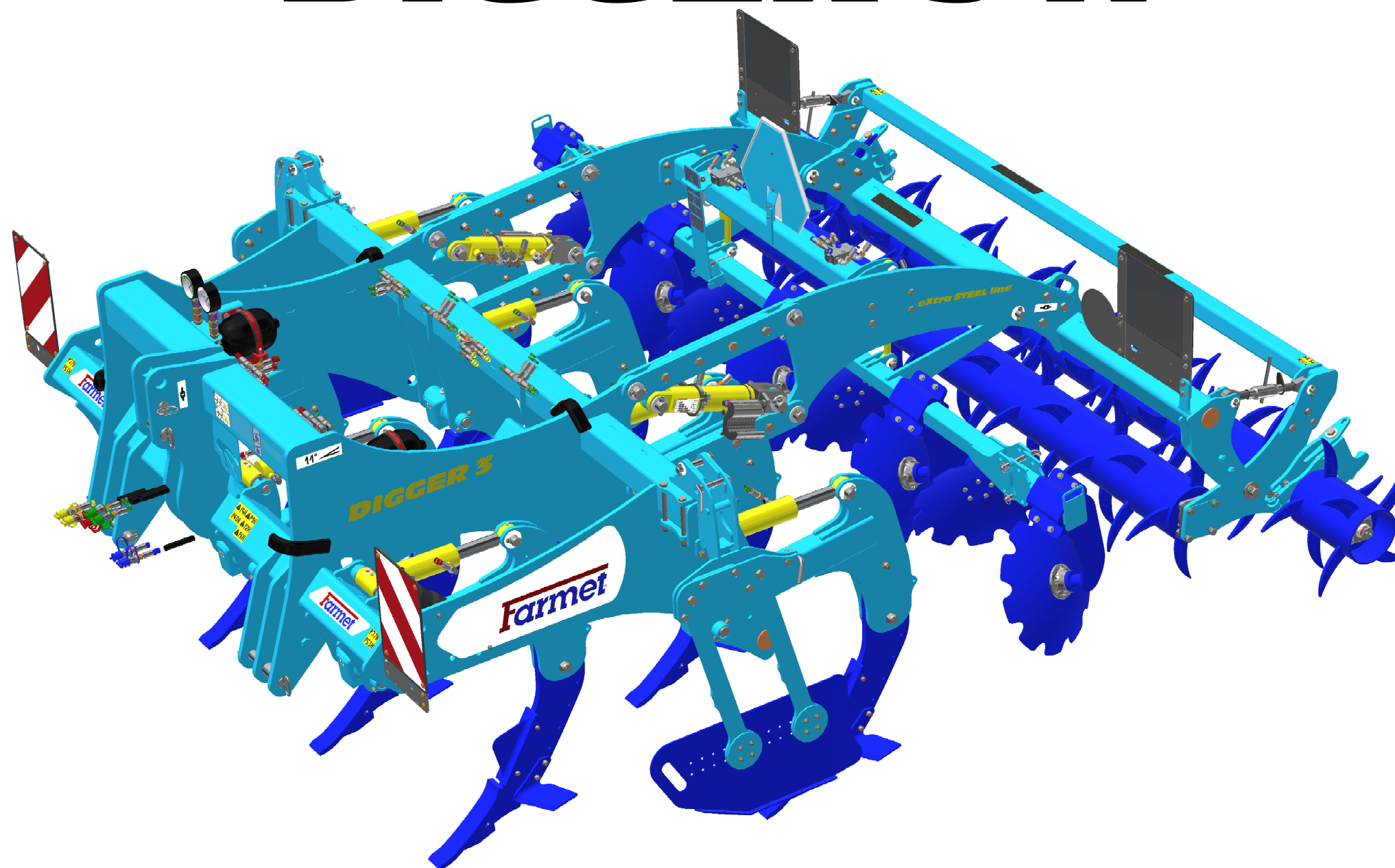

ⒸZ Platnost pro vrcholové | výrobní číslo stroje ⒸB Validity for the top | serial number of the machine
ⒸD Gültigkeit für die Haupt- | Herstellungsnummer der Maschine ⒸRU Действительно для главного | заводского номера машины
ⒸF Validité du numéro de référence | de série de la machine ⒸPL Obowiązuje dla numeru głównego | seryjnego maszyny

9318125 | 2022/0895

Farmet a. s.
Jiřinková 276
552 03 Česká Skalice, CZ

telefon: +420 491 450 111
fax: +420 491 450 136
GSM: +420 774 715 738

IČ: 46504931
DIČ: CZ46504931

web: www.farmet.cz
e-mail: farmet@farmet.cz

ⒸZ NAVIGACE STROJE

Ⓓ NAVIGATION DER MASCHINE

Ⓕ NAVIGATION DE LA MACHINE

ⒸB NAVIGATION OF THE MACHINE

ⒸR НАВИГАЦИЯ МАШИНЫ

ⒸL NAWIGACJA MASZYNY

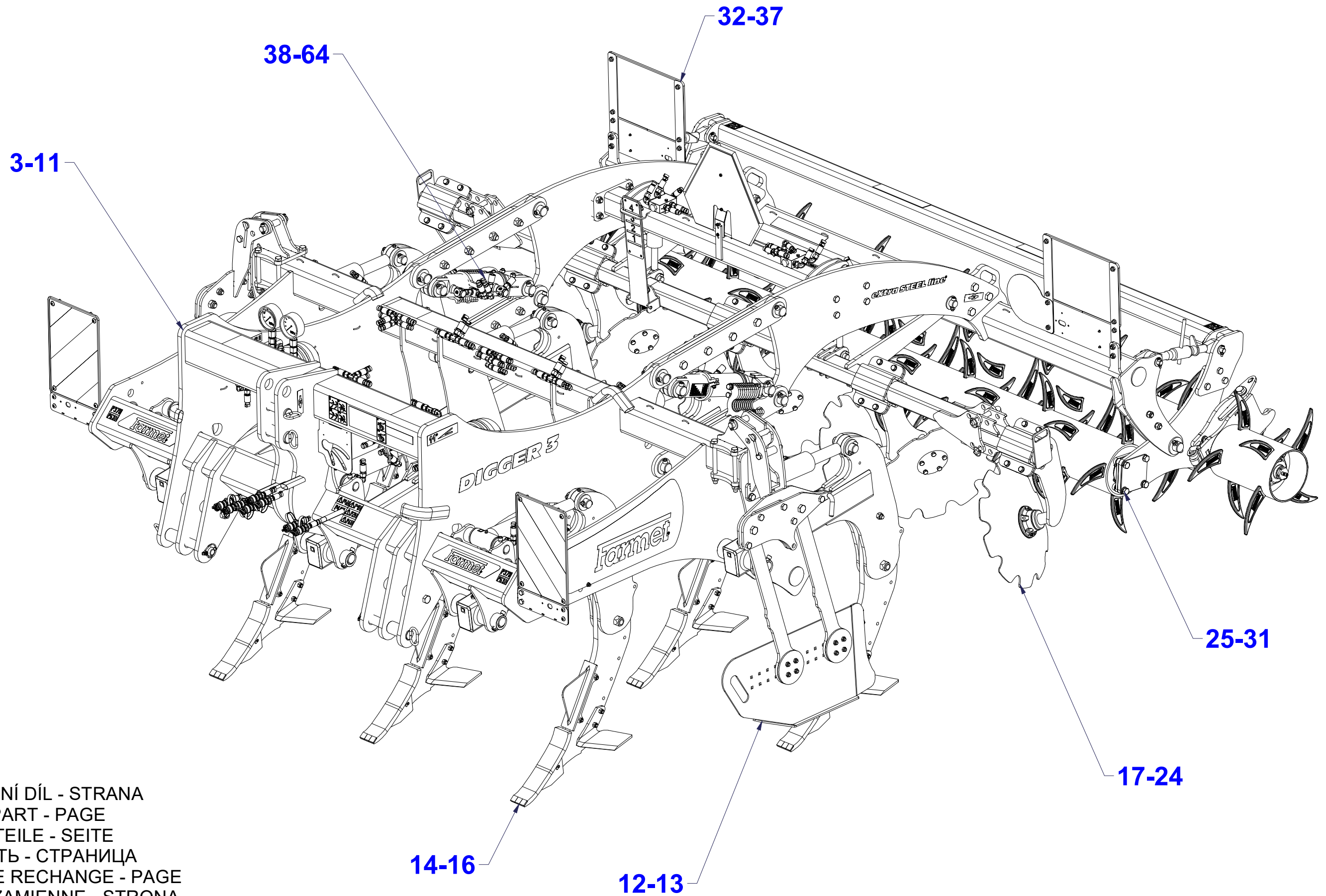

ⒸZ NÁHRADNÍ DÍL - STRANA

ⒸB SPARE PART - PAGE

Ⓓ ERSATZTEILE - SEITE

ⒸR ЗАПЧАСТЬ - СТРАНИЦА

Ⓕ PIÈCE DE RECHANGE - PAGE

ⒸL CZĘŚCI ZAMIENNE - STRONA

Ⓒ ZÁKLAD STROJE

Ⓓ UNTERBAU DER MASCHINE

Ⓕ BÂTI DE LA MACHINE

Ⓖ FOOTING OF THE MACHINE

Ⓡ ОСНОВАНИЕ МАШИНЫ

Ⓟ PODSTAWA MASZYNY



VZ00015077

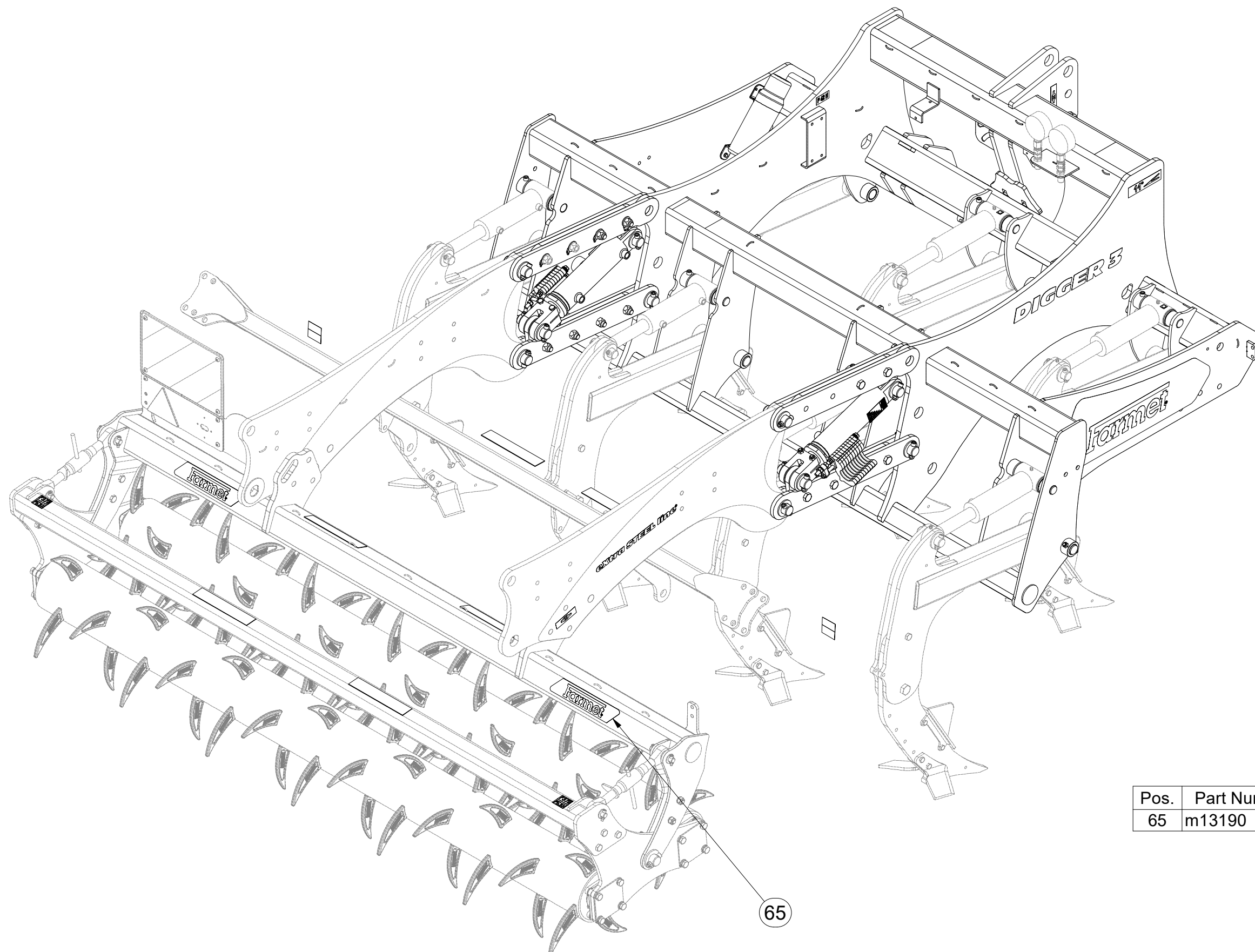

Pos.	Part Number	Pcs.
65	m13190	1

Ⓒ ZÁKLAD STROJE

Ⓓ UNTERBAU DER MASCHINE

Ⓕ BÂTI DE LA MACHINE

Ⓖ FOOTING OF THE MACHINE

Ⓡ ОСНОВАНИЕ МАШИНЫ

Ⓟ PODSTAWA MASZyny



VZ00015077

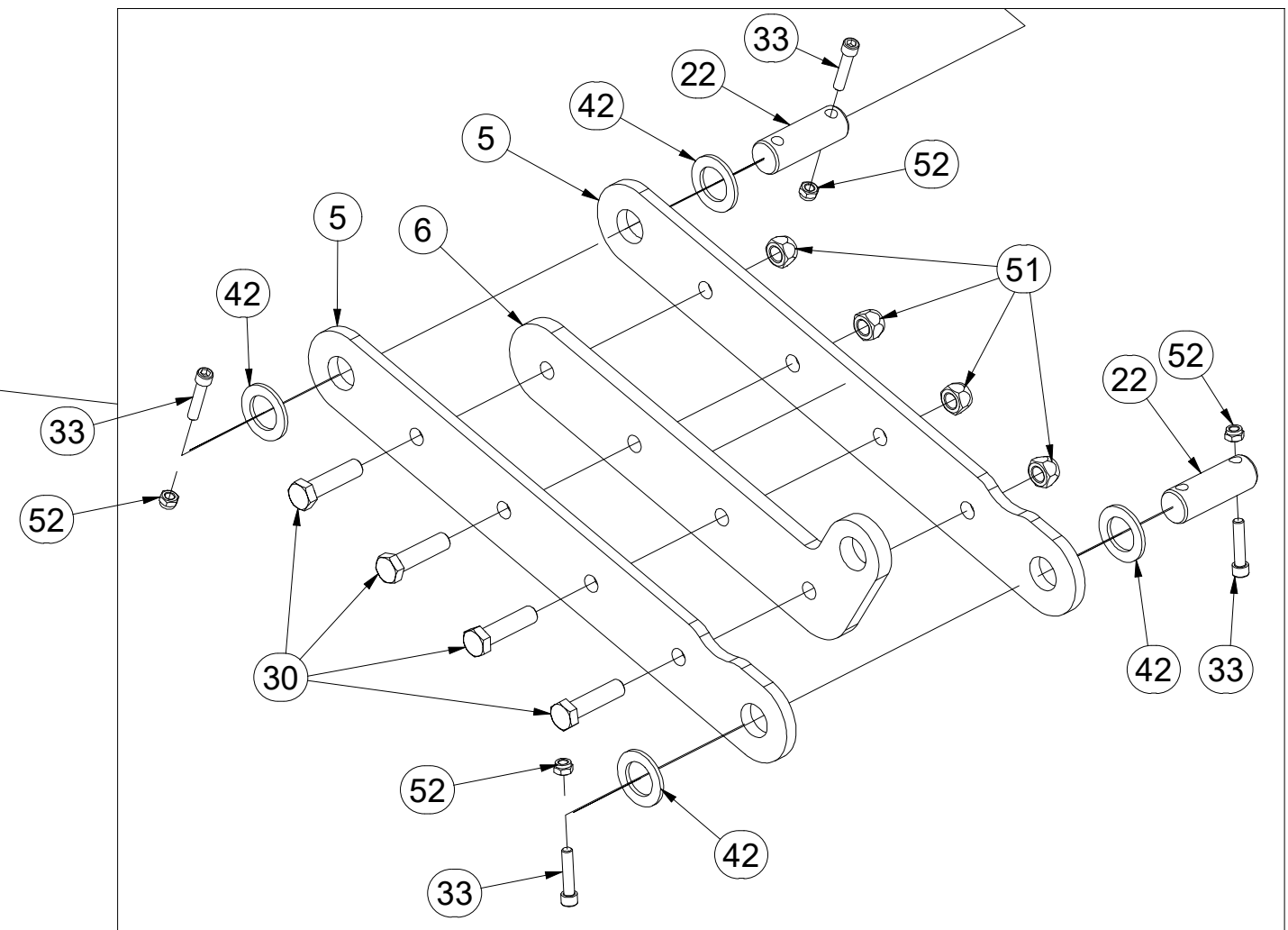
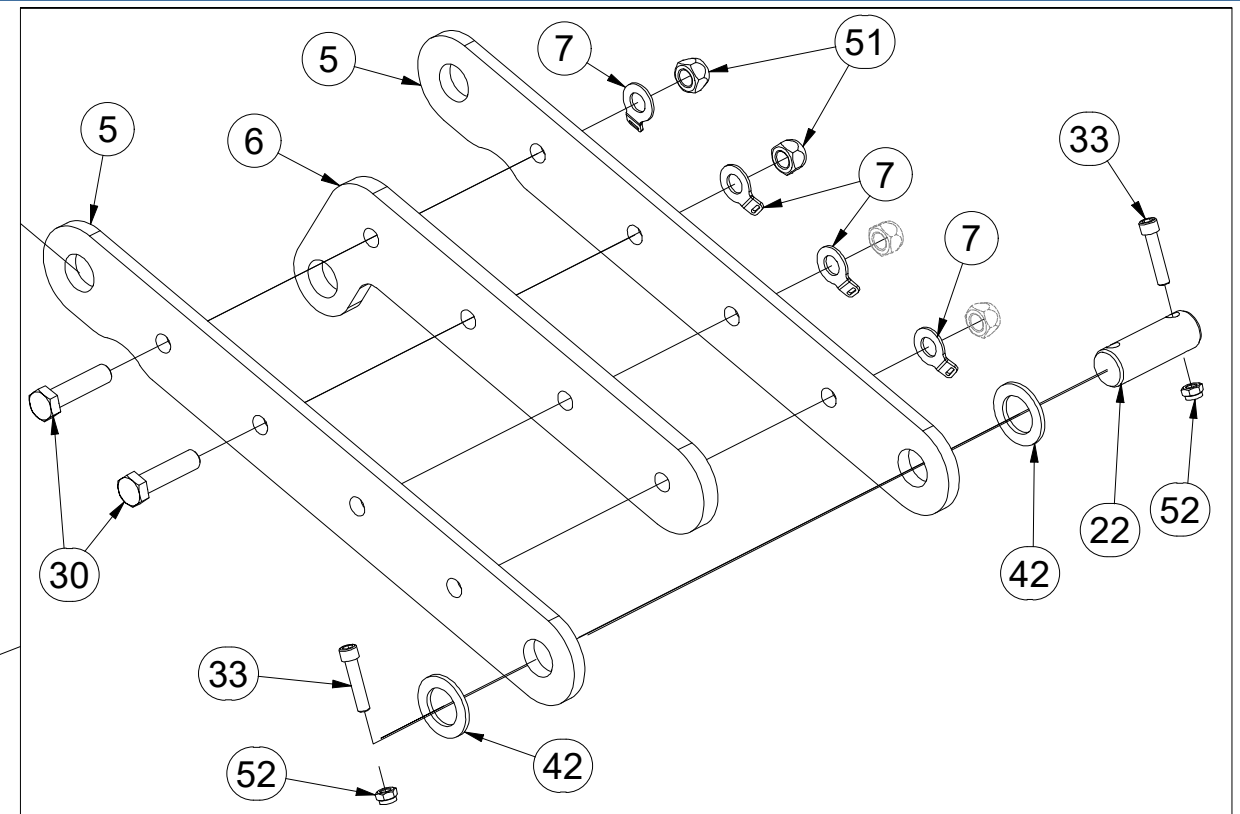
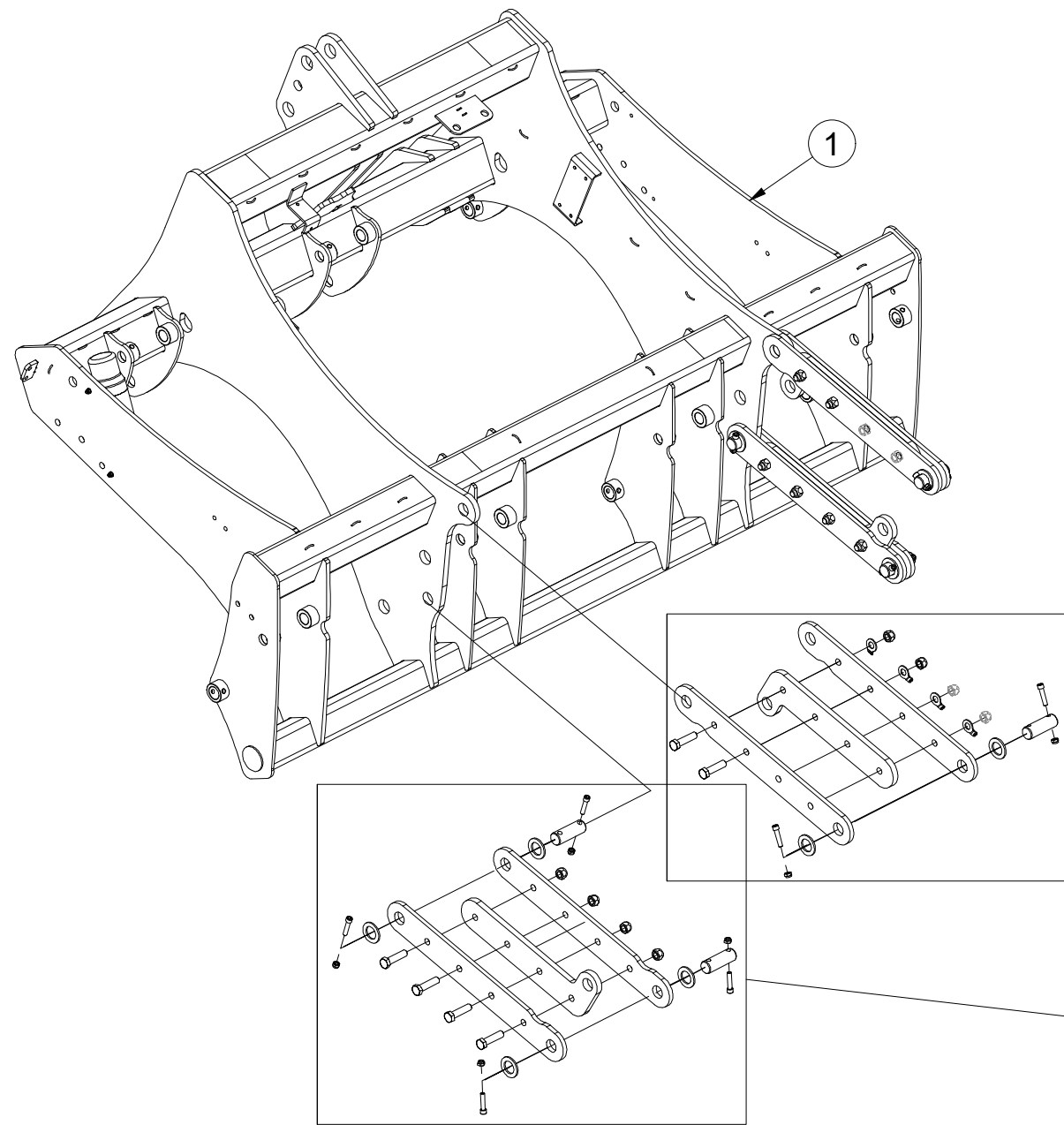

Pos.	Part Number	Pcs.	Pos.	Part Number	Pcs.
1	VZ00011975	1	30	m11528	12
5	4010886	8	33	m14008	20
6	4010885	4	42	4013139	20
7	4010981	4	51	m11169	12
22	4008055	6	52	m04301	20

Ⓒ ZÁKLAD STROJE

Ⓓ UNTERBAU DER MASCHINE

Ⓕ BÂTI DE LA MACHINE

Ⓖ FOOTING OF THE MACHINE

Ⓡ ОСНОВАНИЕ МАШИНЫ

Ⓢ PODSTAWA MASZYNY



VZ00015077

Pos.	Part Number	Pcs.
10	4013839	2
23	4007816	2
24	4012990	2
33	m14008	20
41	m03175	4
42	4013139	20
52	m04301	20

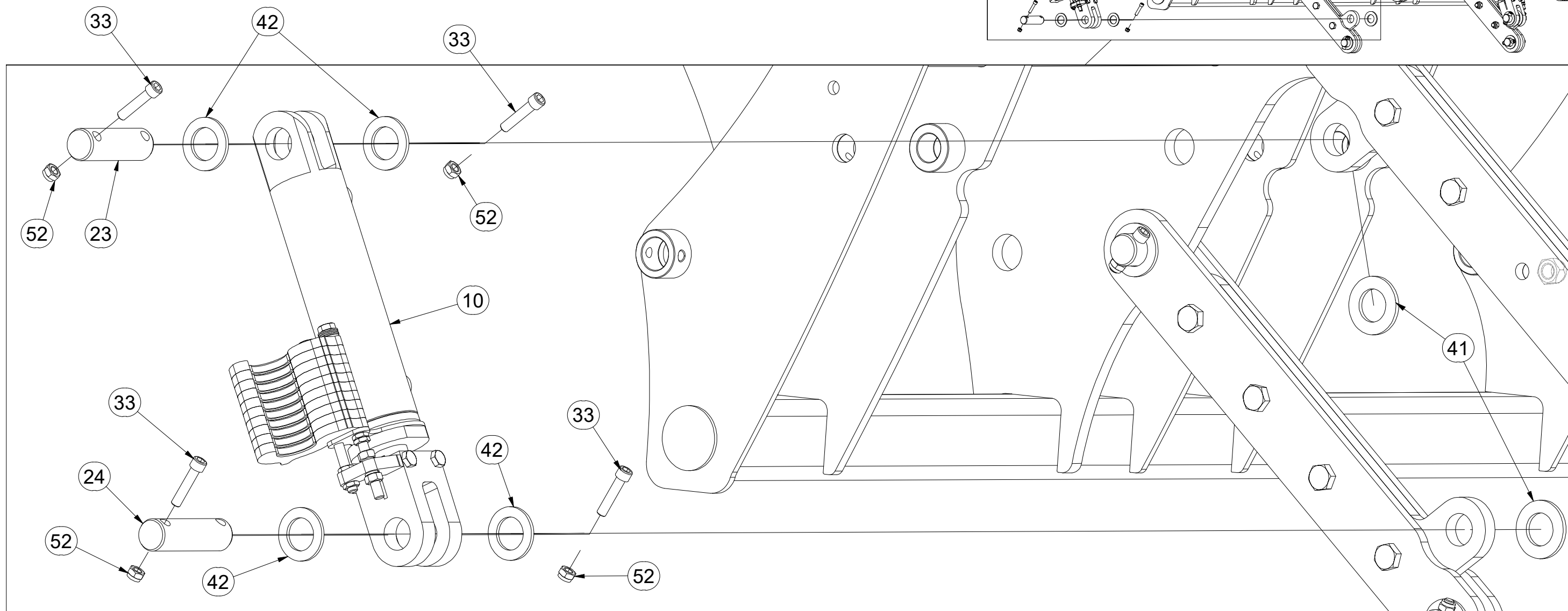

Ⓒ ZÁKLAD STROJE

Ⓓ UNTERBAU DER MASCHINE

Ⓕ BÂTI DE LA MACHINE

VZ00015077

Ⓖ FOOTING OF THE MACHINE

Ⓡ ОСНОВАНИЕ МАШИНЫ

Ⓟ PODSTAWA MASZyny

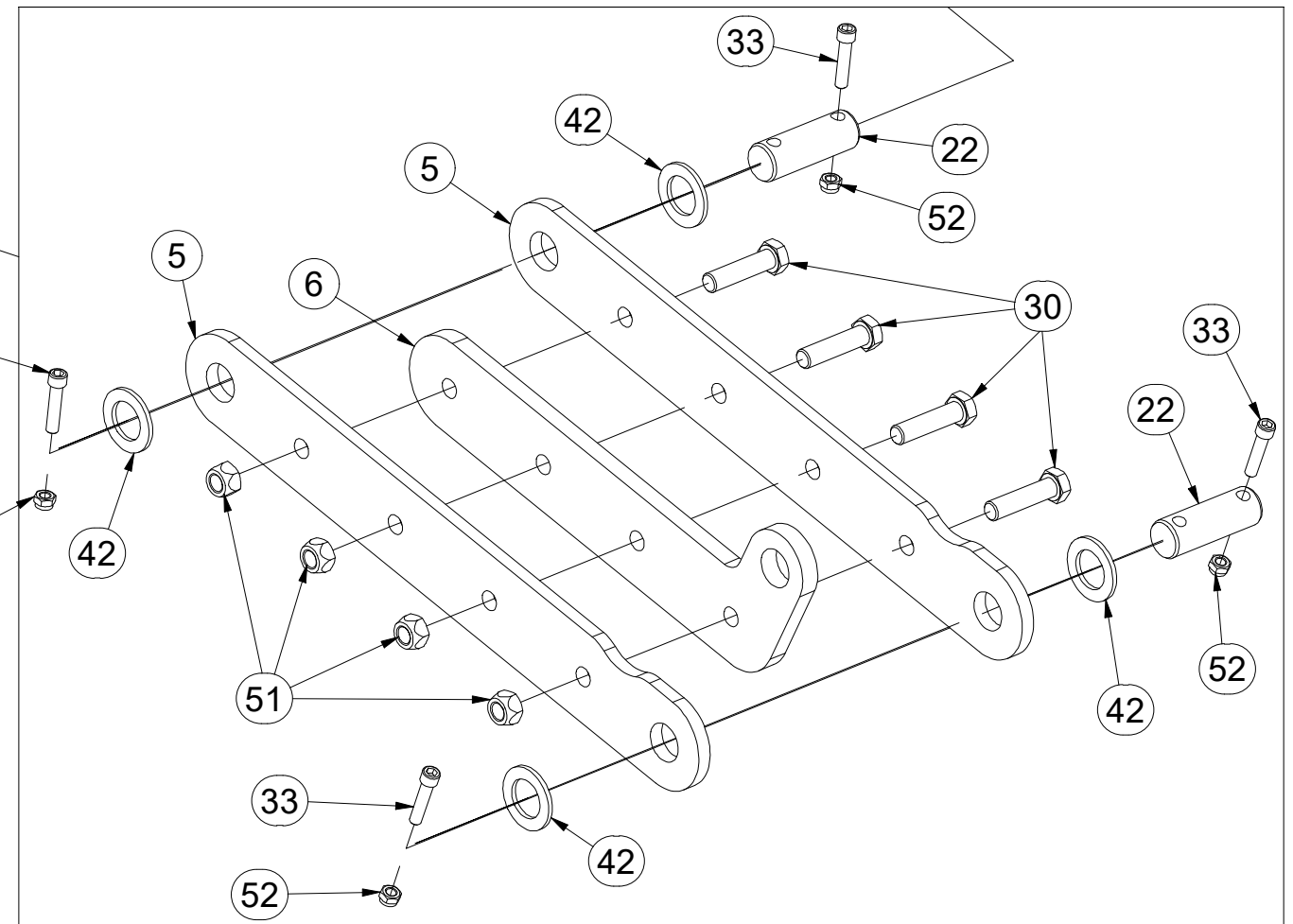
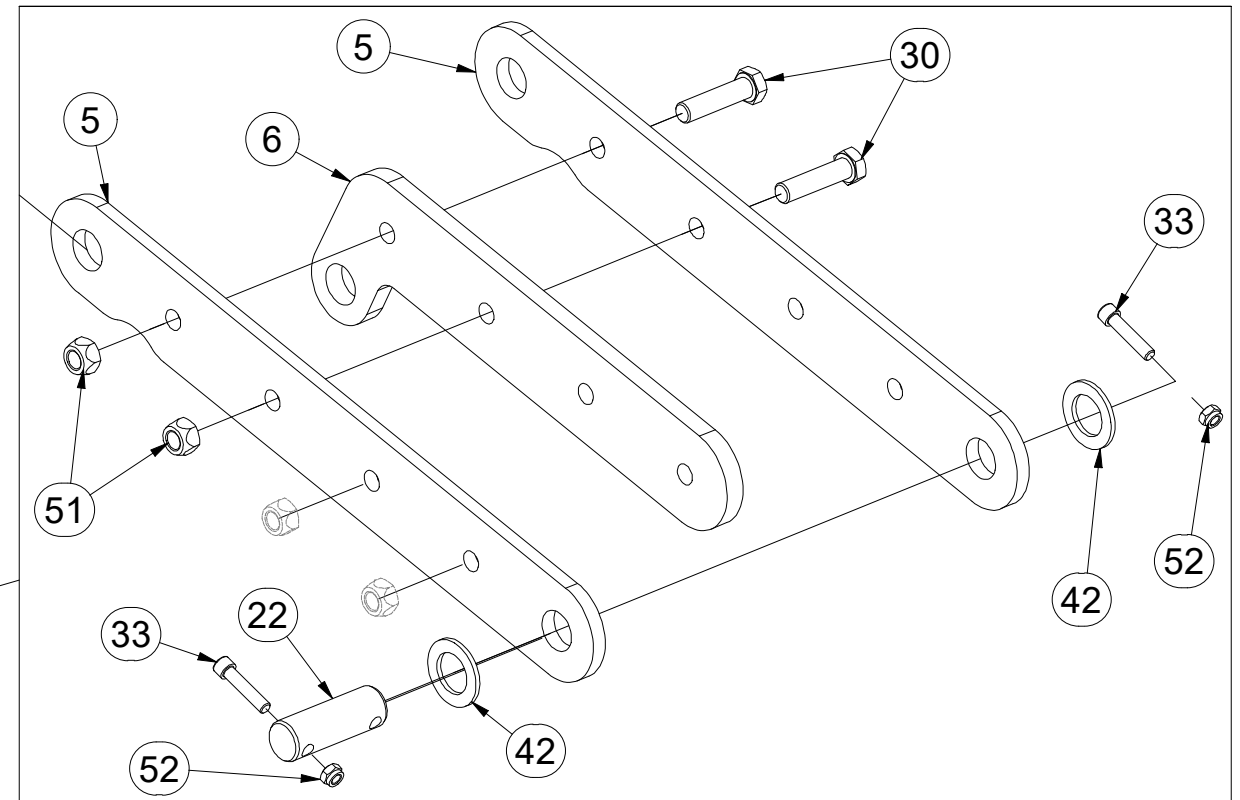
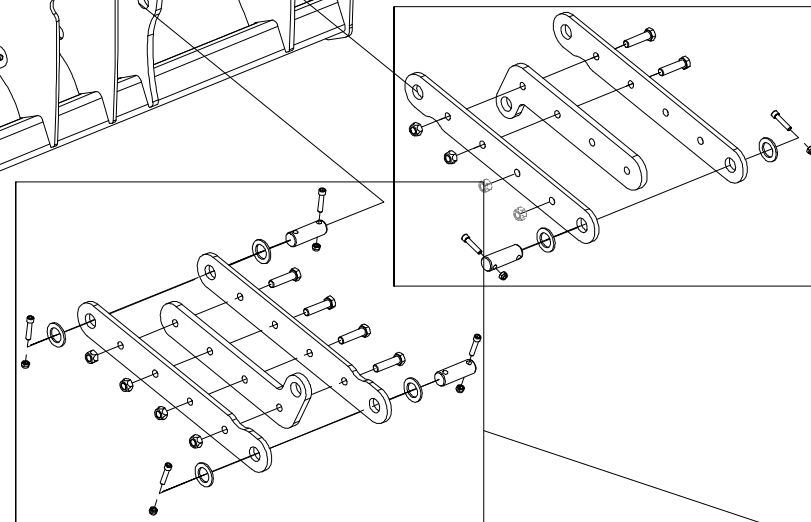
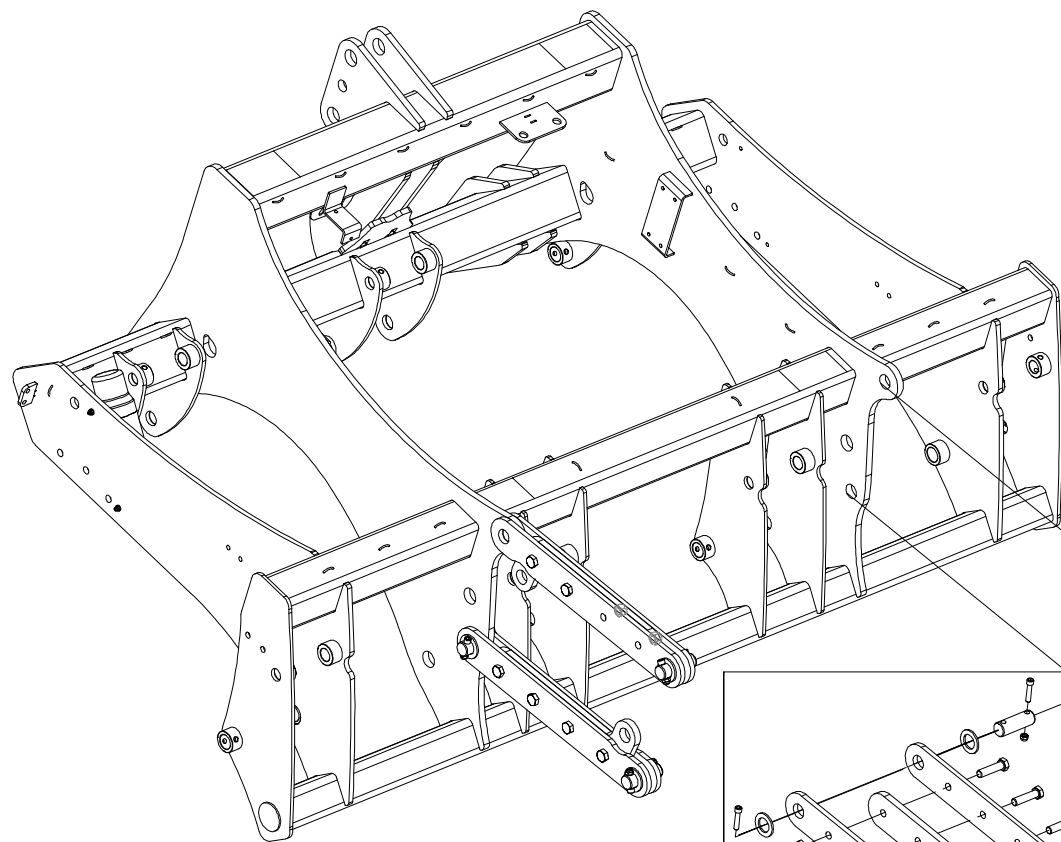

Pos.	Part Number	Pcs.
5	4010886	8
6	4010885	4
22	4008055	6
30	m11528	12
33	m14008	20
42	4013139	20
51	m11169	12
52	m04301	20

Ⓒ ZÁKLAD STROJE

Ⓓ UNTERBAU DER MASCHINE

Ⓕ BÂTI DE LA MACHINE

VZ00015077

Ⓖ FOOTING OF THE MACHINE

Ⓡ ОСНОВАНИЕ МАШИНЫ

Ⓢ PODSTAWA MASZINY

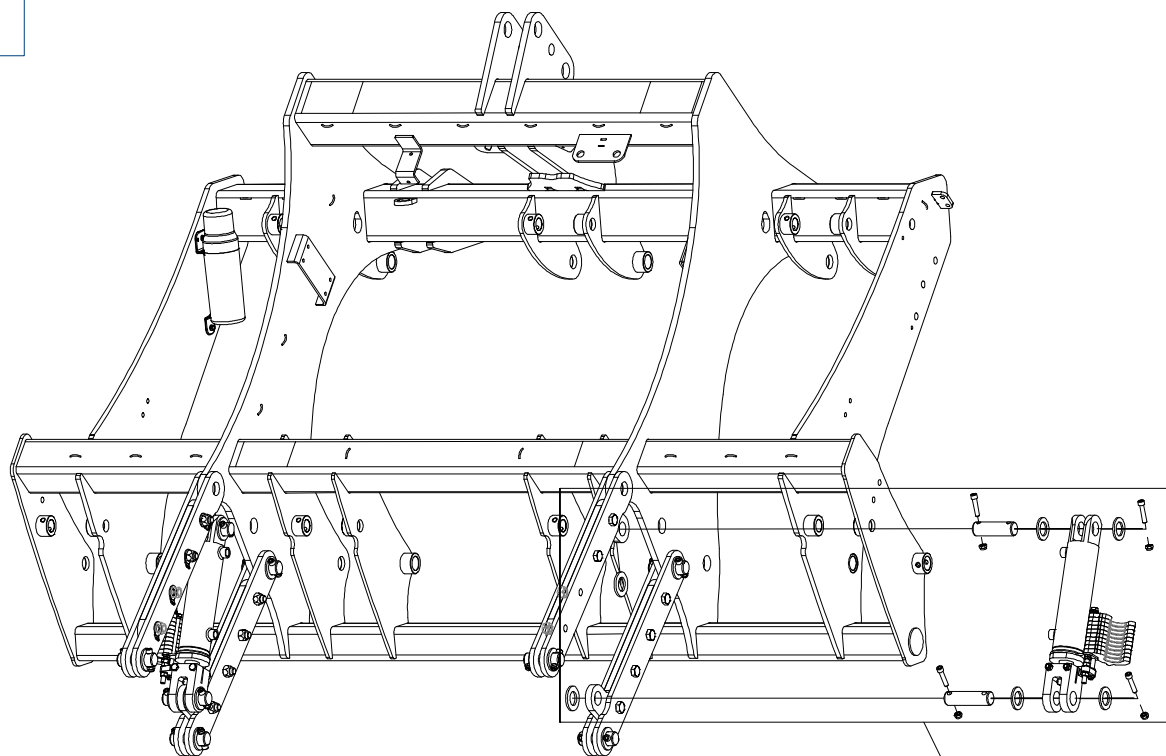

Pos.	Part Number	Pcs.
10	4013839	2
23	4007816	2
24	4012990	2
33	m14008	20
41	m03175	4
42	4013139	20
52	m04301	20

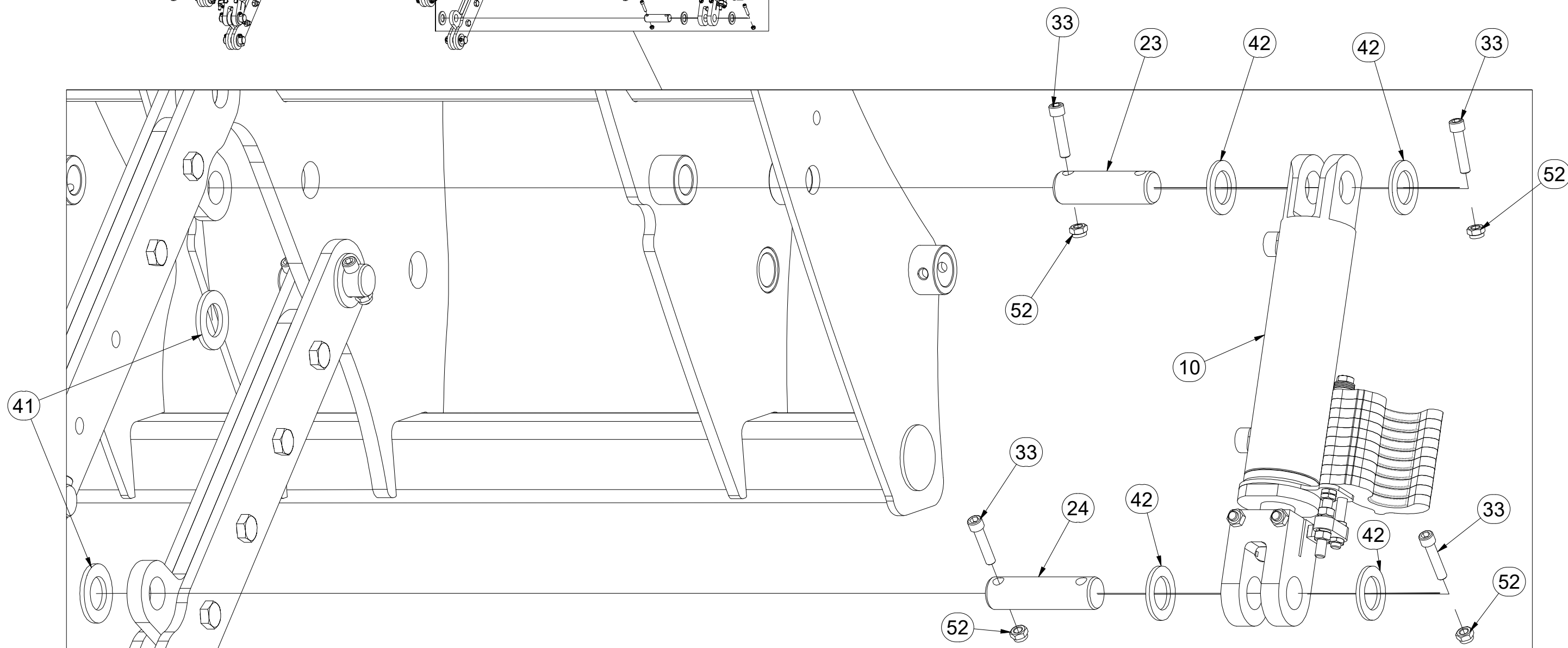

Ⓒ ZÁKLAD STROJE

Ⓓ UNTERBAU DER MASCHINE

Ⓕ BÂTI DE LA MACHINE

Ⓖ FOOTING OF THE MACHINE

Ⓡ ОСНОВАНИЕ МАШИНЫ

Ⓢ PODSTAWA MASZYNY



VZ00015077

Pos.	Part Number	Pcs.
15	4010806	2
16	4010762	1
20	4010786	7
21	4010782	7
32	m13033	14
40	m03866	14
50	m12134	14

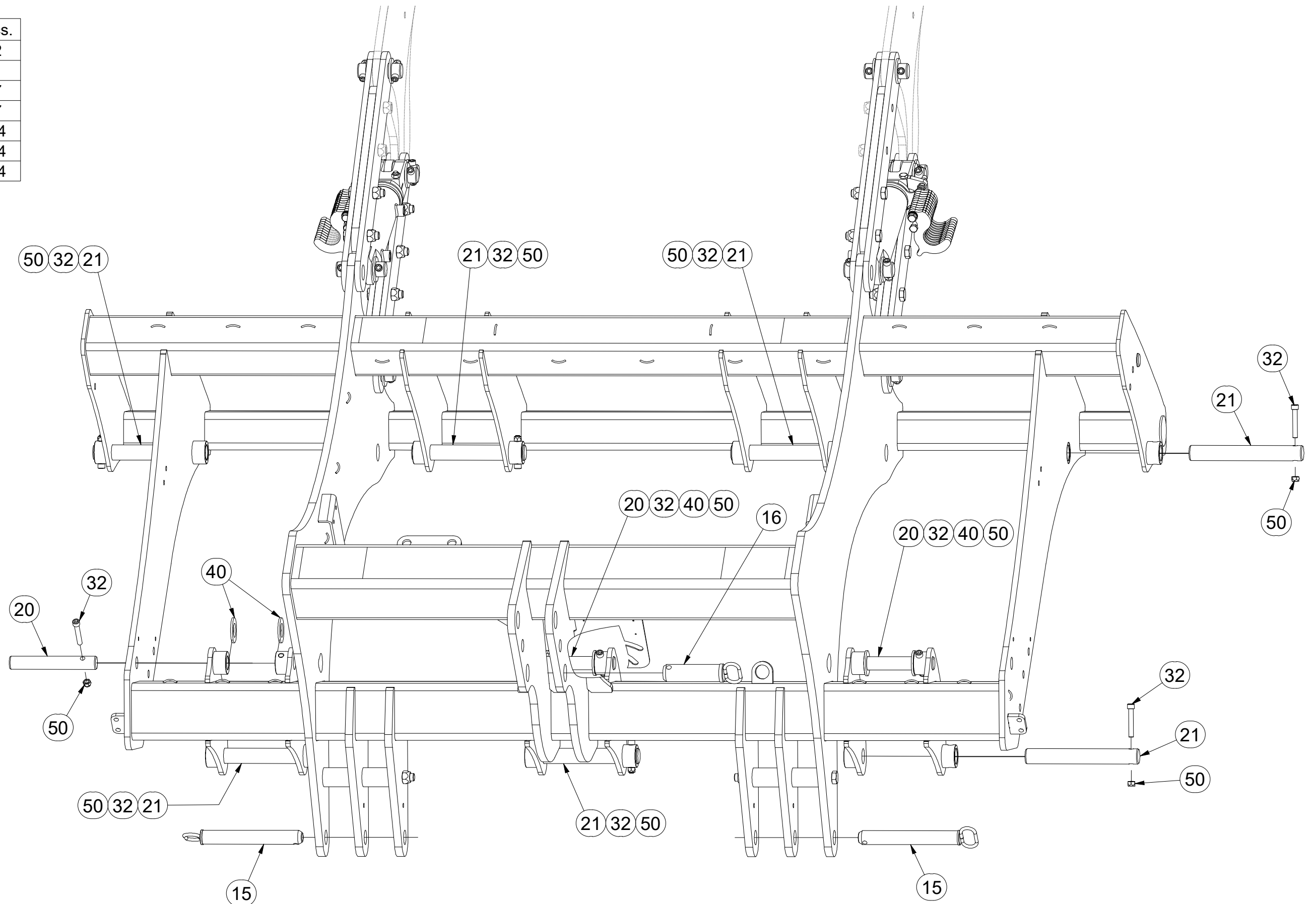

Ⓒ ZÁKLAD STROJE

Ⓓ UNTERBAU DER MASCHINE

Ⓕ BÂTI DE LA MACHINE

VZ00015077

Ⓖ FOOTING OF THE MACHINE

Ⓡ ОСНОВАНИЕ МАШИНЫ

Ⓟ PODSTAWA MASZYNY



Pos.	Part Number	Pcs.
31	m01096	2
43	m01203	4
53	m04503	2
60	m15900	1
66	m02579	2

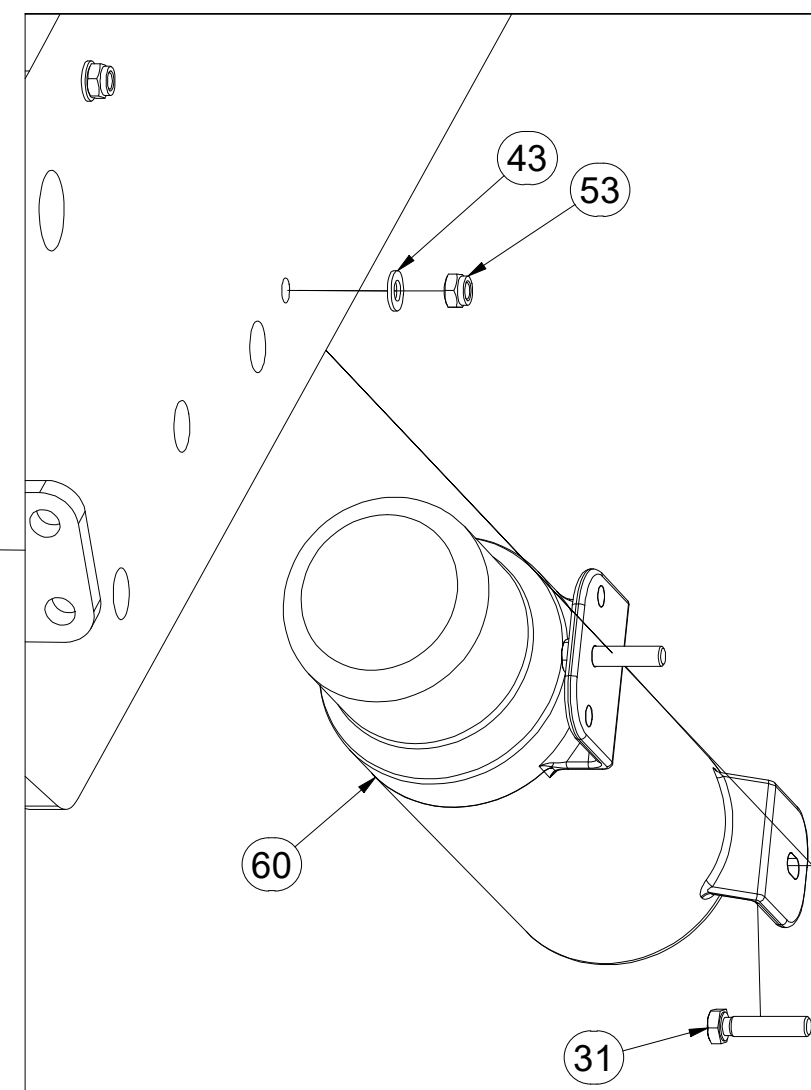
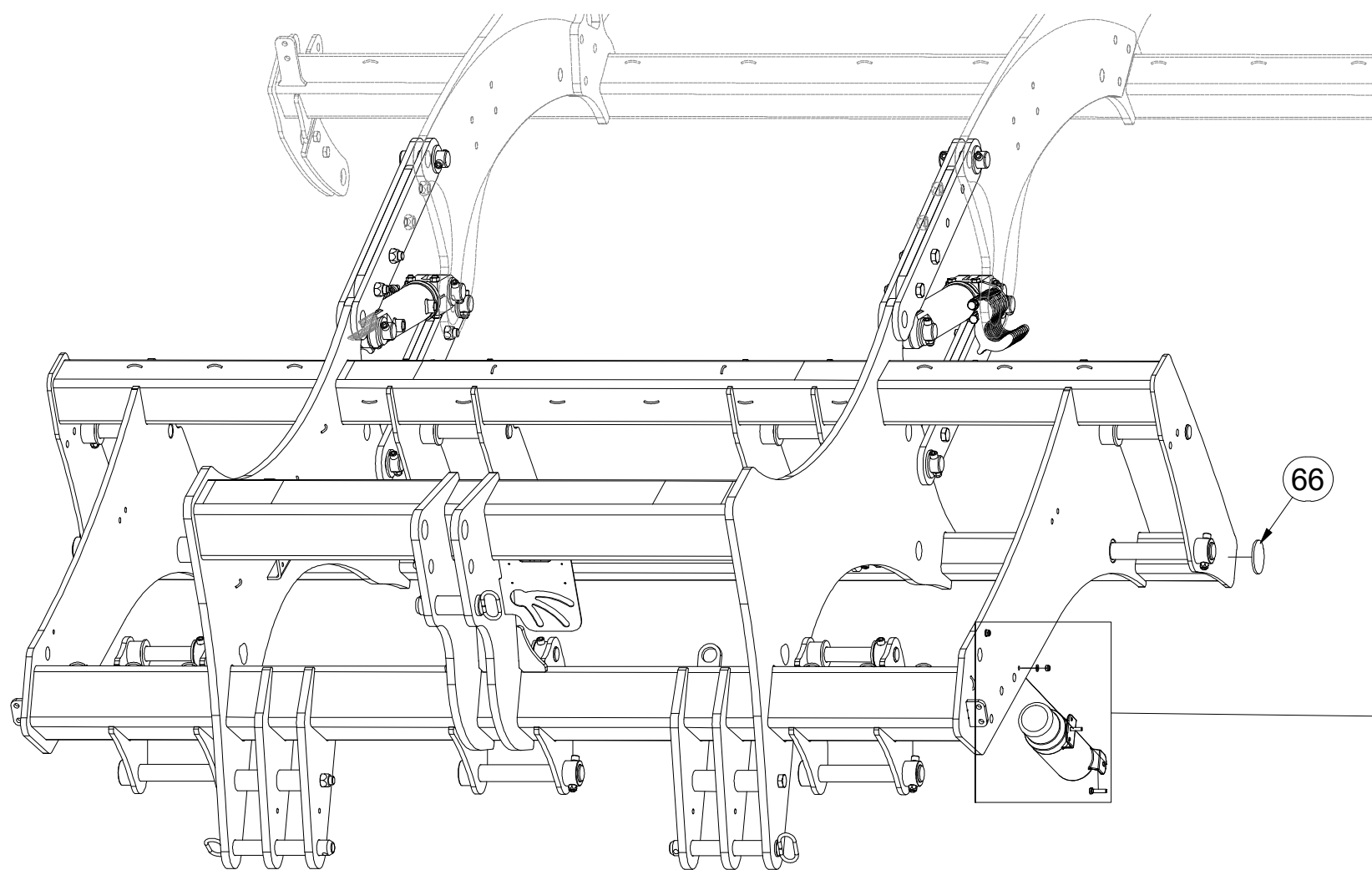

Ⓒ ZÁKLAD STROJE

Ⓓ UNTERBAU DER MASCHINE

Ⓕ BÂTI DE LA MACHINE

VZ00015078

Ⓖ FOOTING OF THE MACHINE

Ⓔ ОСНОВАНИЕ МАШИНЫ

Ⓗ PODSTAWA MASZYNY

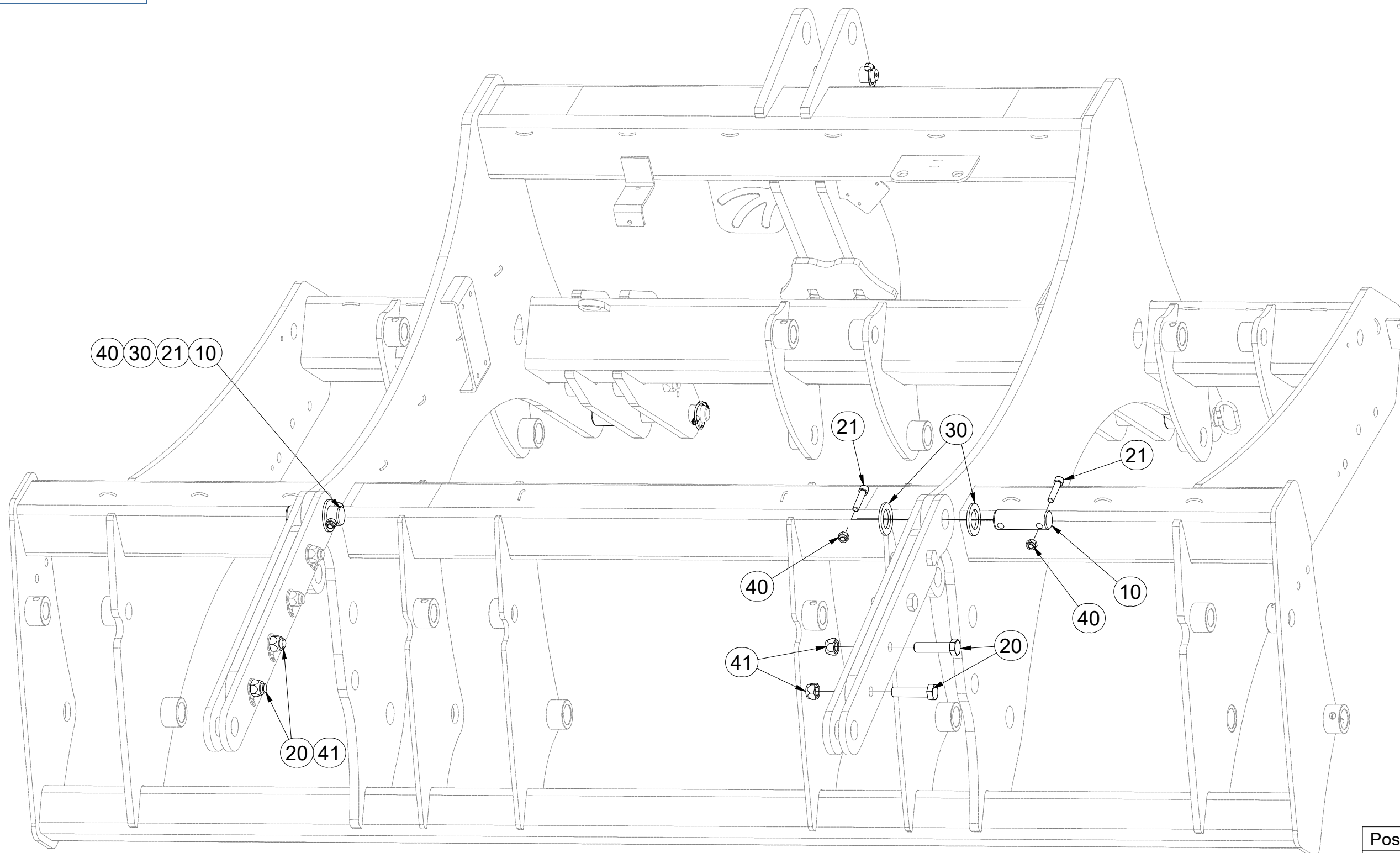

Pos.	Part Number	Pcs.
10	4008055	2
20	m11528	4
21	m14008	4
30	4013139	4
40	m04301	4
41	m11169	4

☉ ZÁKLAD STROJE

☉ UNTERBAU DER MASCHINE

☉ BÂTI DE LA MACHINE

VZ00015078

☉ FOOTING OF THE MACHINE

☉ ОСНОВАНИЕ МАШИНЫ

☉ PODSTAWA MASZYNY

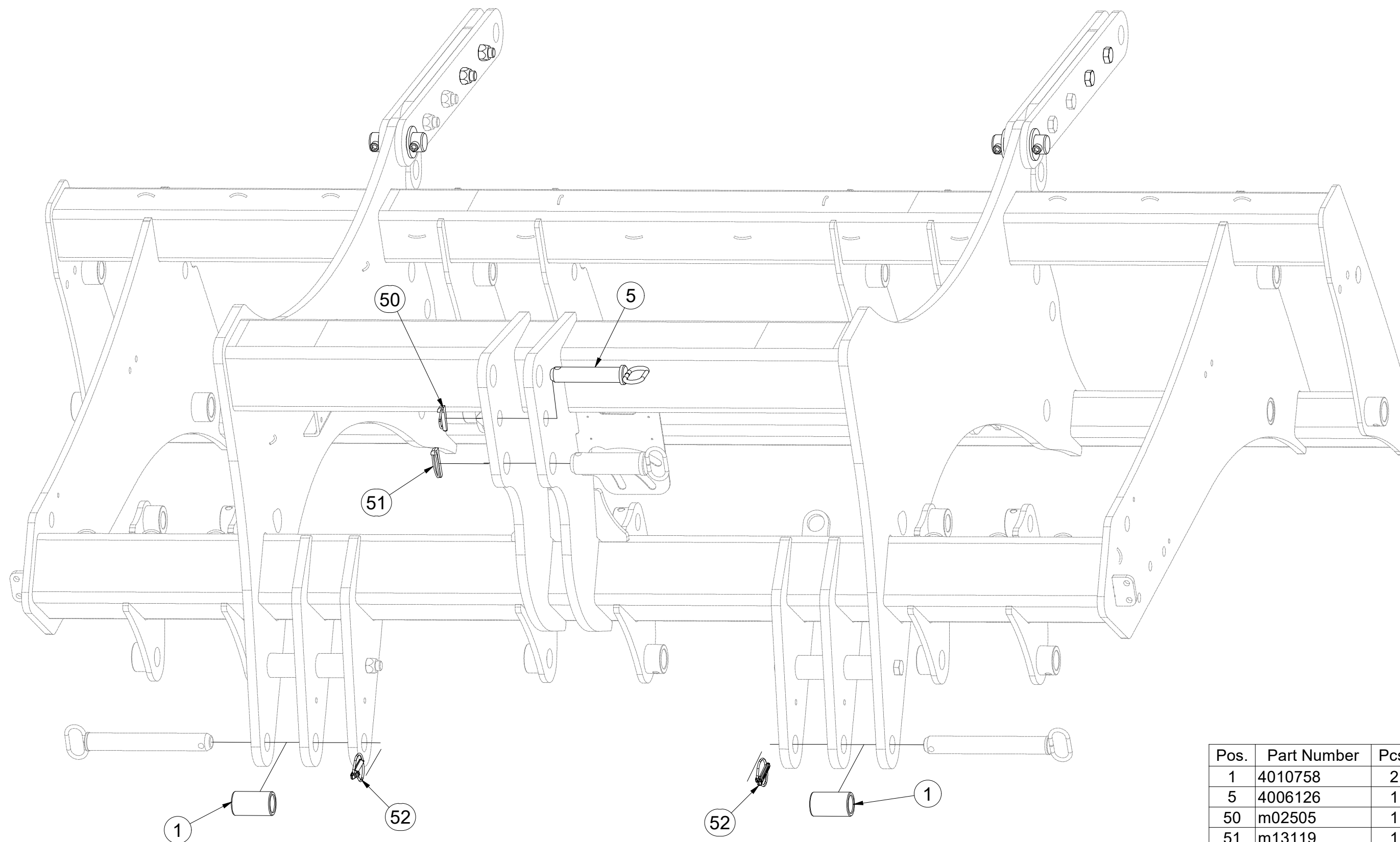

Pos.	Part Number	Pcs.
1	4010758	2
5	4006126	1
50	m02505	1
51	m13119	1
52	m21895	2

- Ⓒ SADA DEFLEKTORŮ
- Ⓓ DEFLEKTORSATZ
- Ⓕ KIT DE DÉFLECTEURS

VZ00006155

- Ⓖ SET OF DEFLECTORS
- Ⓔ КОМПЛЕКТ ДЕФЛЕКТОРОВ
- Ⓗ ZESTAW DEFLEKTORÓW

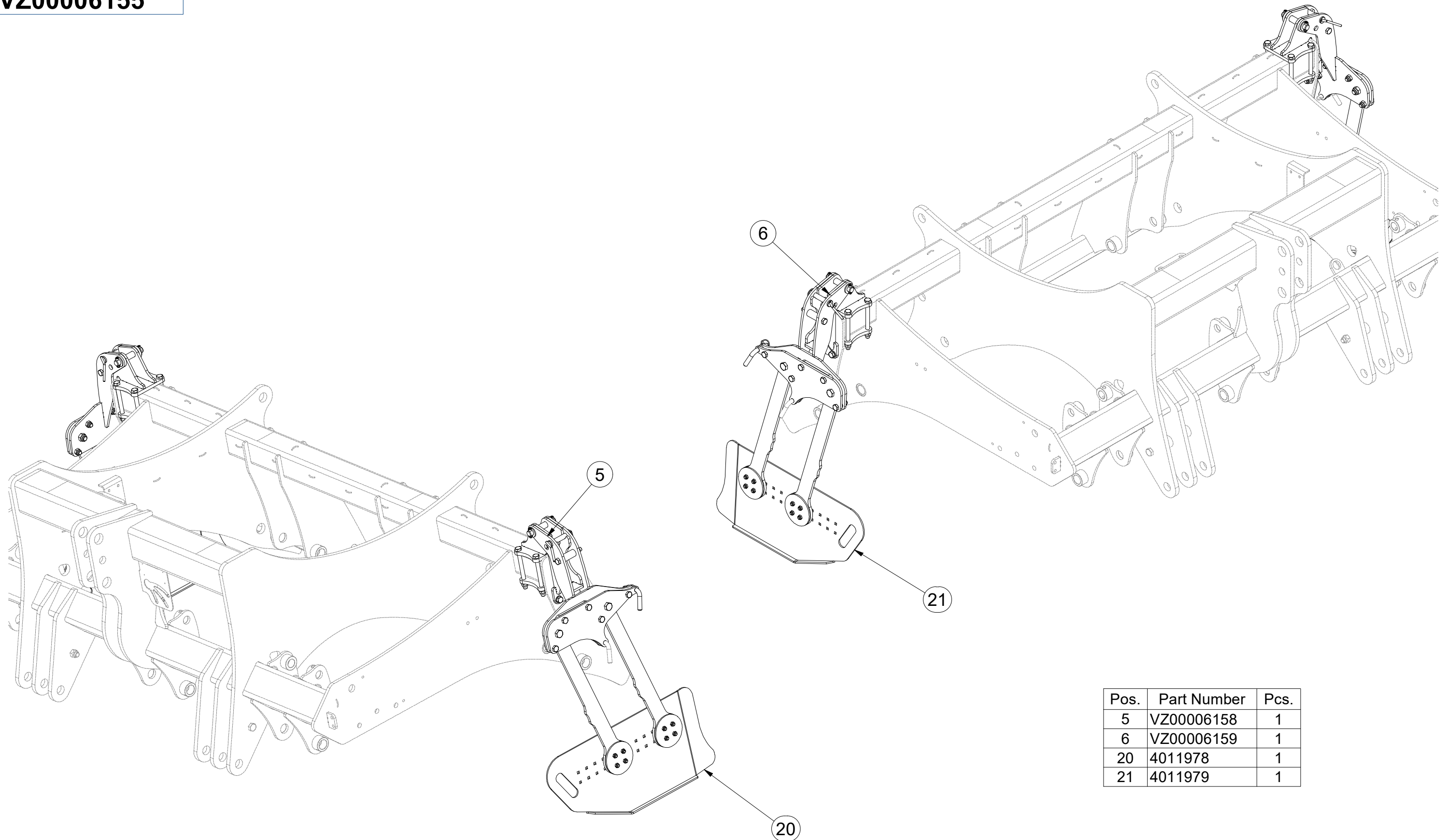

Pos.	Part Number	Pcs.
5	VZ00006158	1
6	VZ00006159	1
20	4011978	1
21	4011979	1

☉ SADA DEFLEKTORŮ

☉ DEFLEKTORSATZ

☉ KIT DE DÉFLECTEURS

☉ SET OF DEFLECTORS

☉ КОМПЛЕКТ ДЕФЛЕКТОРОВ

☉ ZESTAW DEFLEKTORÓW



VZ00006155

Pos.	Part Number	Pcs.	Pos.	Part Number	Pcs.
1	VZ00007695	2	35	m10454	4
2	4011986	2	40	m05747	4
5	VZ00006158	1	41	m13816	8
7	4011991	2	42	m10112	10
8	4012034	2	43	m02254	4
9	4012062	10	44	m12687	16
15	4011989	4	45	m09464	4
16	4011988	4	50	m01219	12
17	4011990	4	51	m14028	4
20	4011978	1	60	m05648	4
30	4008605	2	61	m03683	22
31	4009494	2	62	m03775	16
32	m13466	2	63	m04503	4

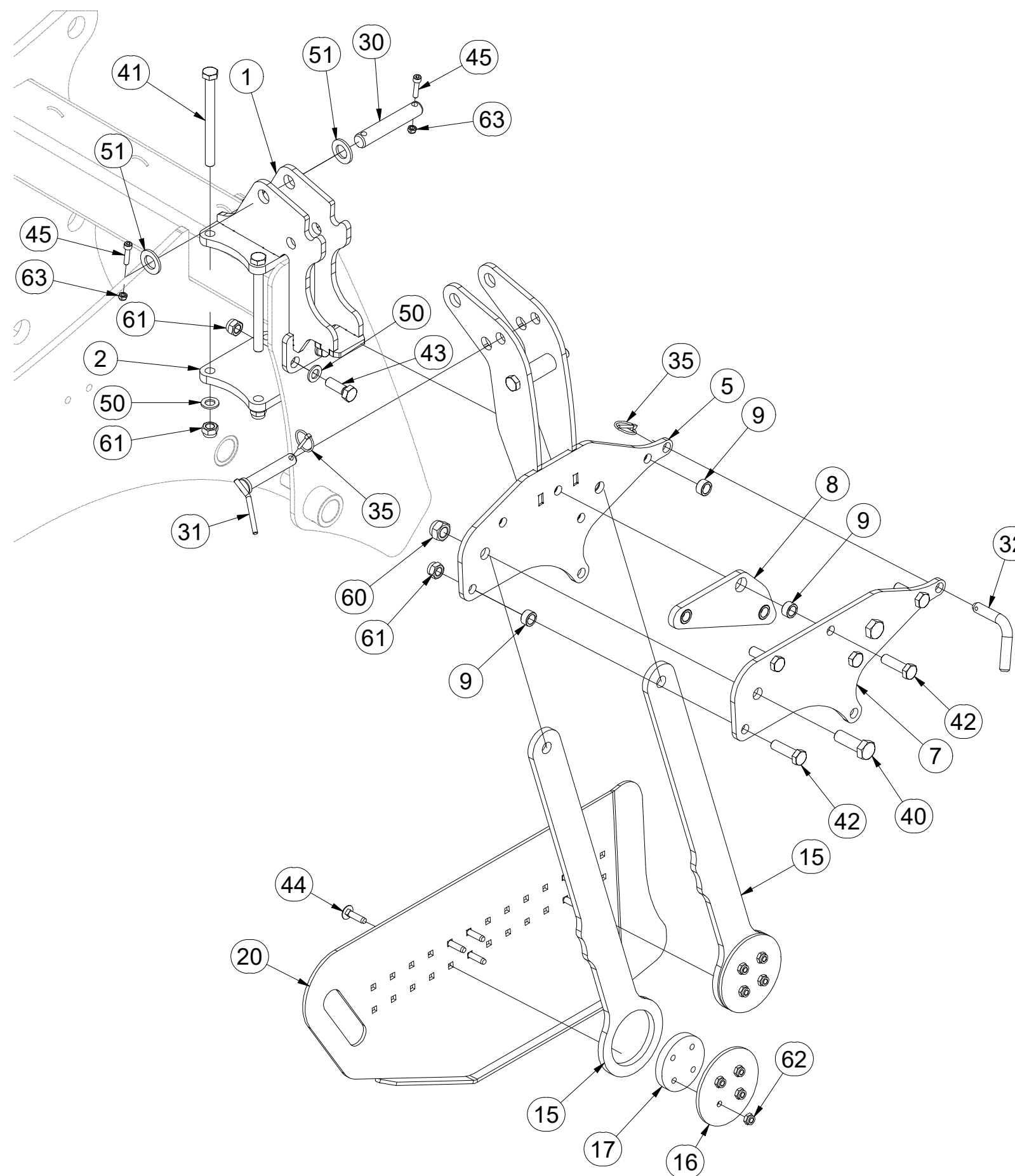
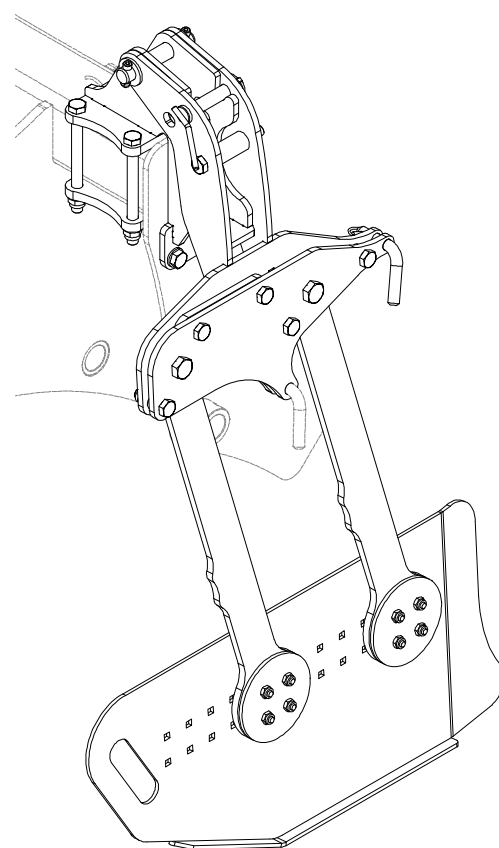

Ⓒ SADA RADLIC

Ⓓ SCHARSATZ

Ⓕ KIT DE SOCS

VZ00014394

Ⓖ SET OF PLOUGHSHARES

Ⓡ КОМПЛЕКТ ЛАП

Ⓢ ZESTAW REDLIC

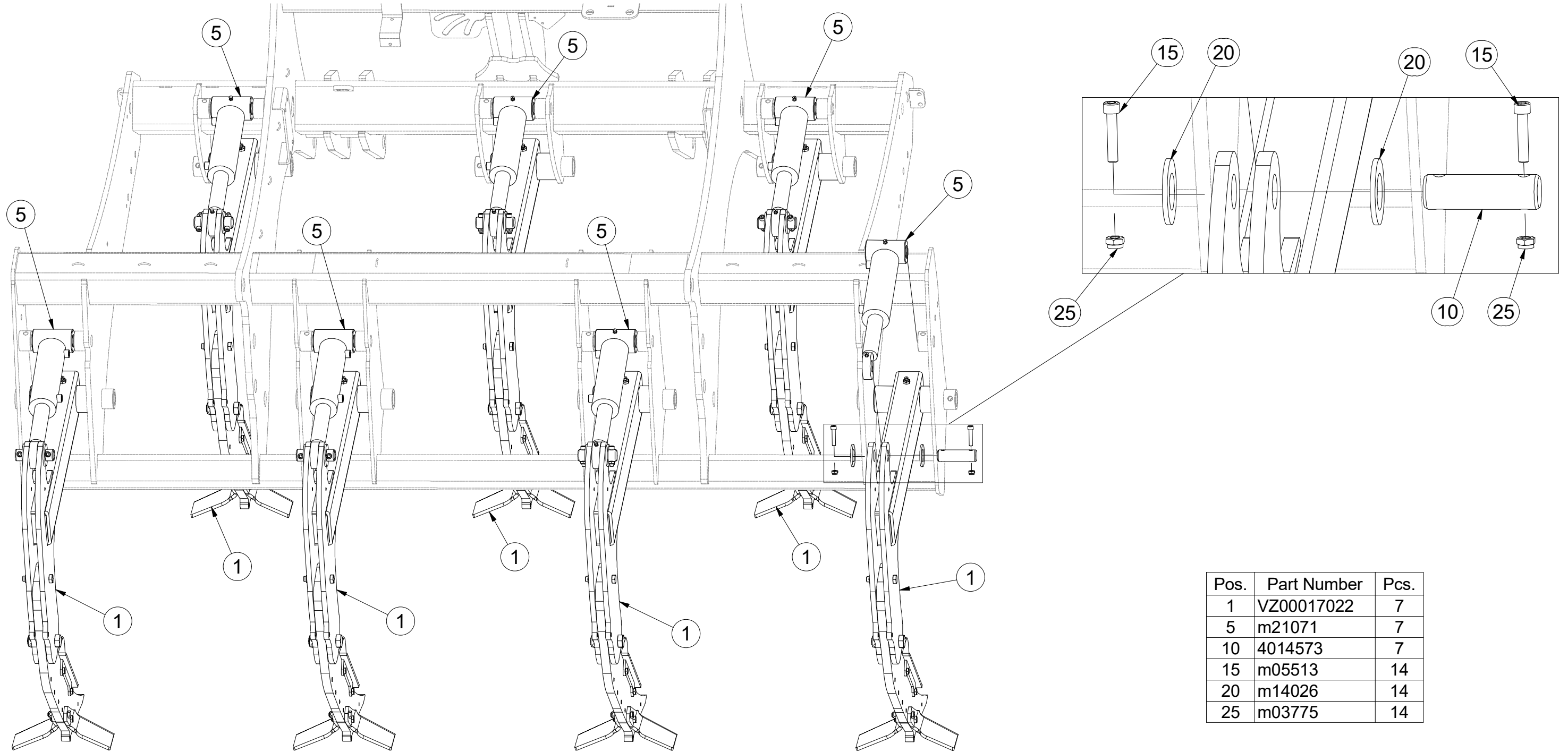

Pos.	Part Number	Pcs.
1	VZ00017022	7
5	m21071	7
10	4014573	7
15	m05513	14
20	m14026	14
25	m03775	14

Ⓒ RADLICE

Ⓓ SCHARE

Ⓕ SOC

Ⓖ SHARE

Ⓡ ЛАПА

Ⓟ REDLICE



VZ00017022

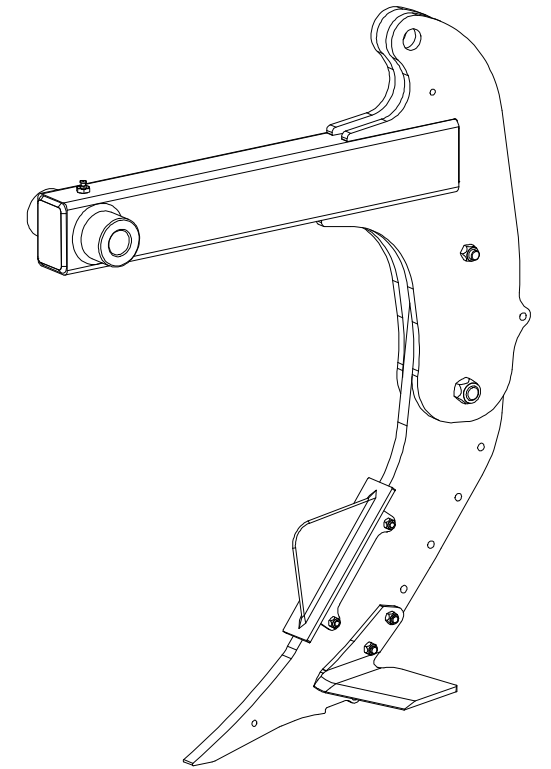
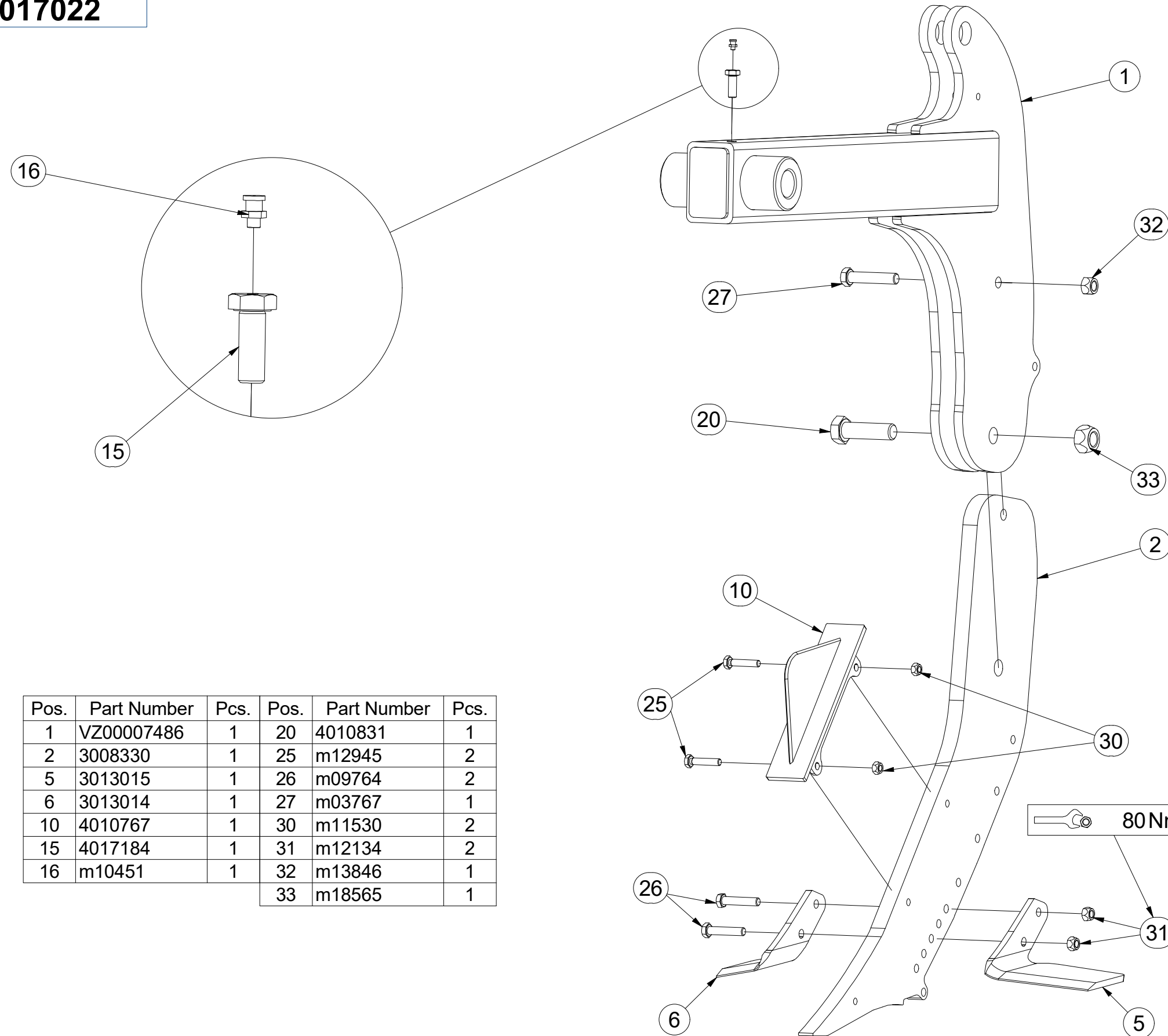

Pos.	Part Number	Pcs.	Pos.	Part Number	Pcs.
1	VZ00007486	1	20	4010831	1
2	3008330	1	25	m12945	2
5	3013015	1	26	m09764	2
6	3013014	1	27	m03767	1
10	4010767	1	30	m11530	2
15	4017184	1	31	m12134	2
16	m10451	1	32	m13846	1
			33	m18565	1

Ⓒ SADA DLÁT
Ⓓ MIESELSATZ
Ⓕ KIT DE CISEAU

Ⓖ SET OF CHISEL
Ⓔ КОМПЛЕКТ ДОЛОТОВ
Ⓗ ZESTAW DŁUTÓW



3011168

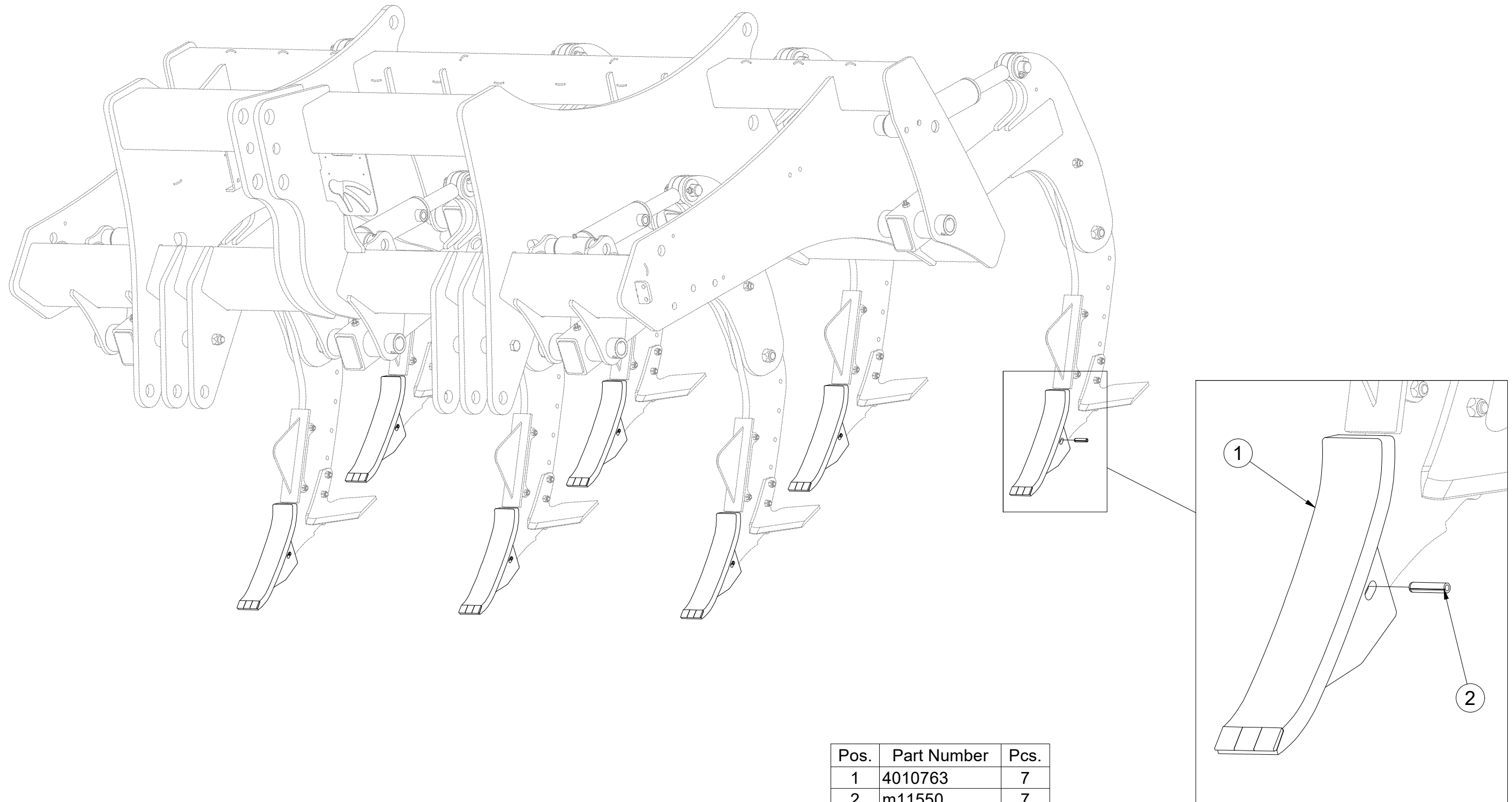

Pos.	Part Number	Pcs.
1	4010763	7
2	m11550	7

- Ⓒ SADA DISKŮ
- Ⓓ SCHEIBENSATZ
- Ⓕ KIT DE DISQUES

- Ⓖ DISC SET
- Ⓡ КОМПЛЕКТ ДИСКОВ
- Ⓟ ZESTAW TALERZY



VZ00010948

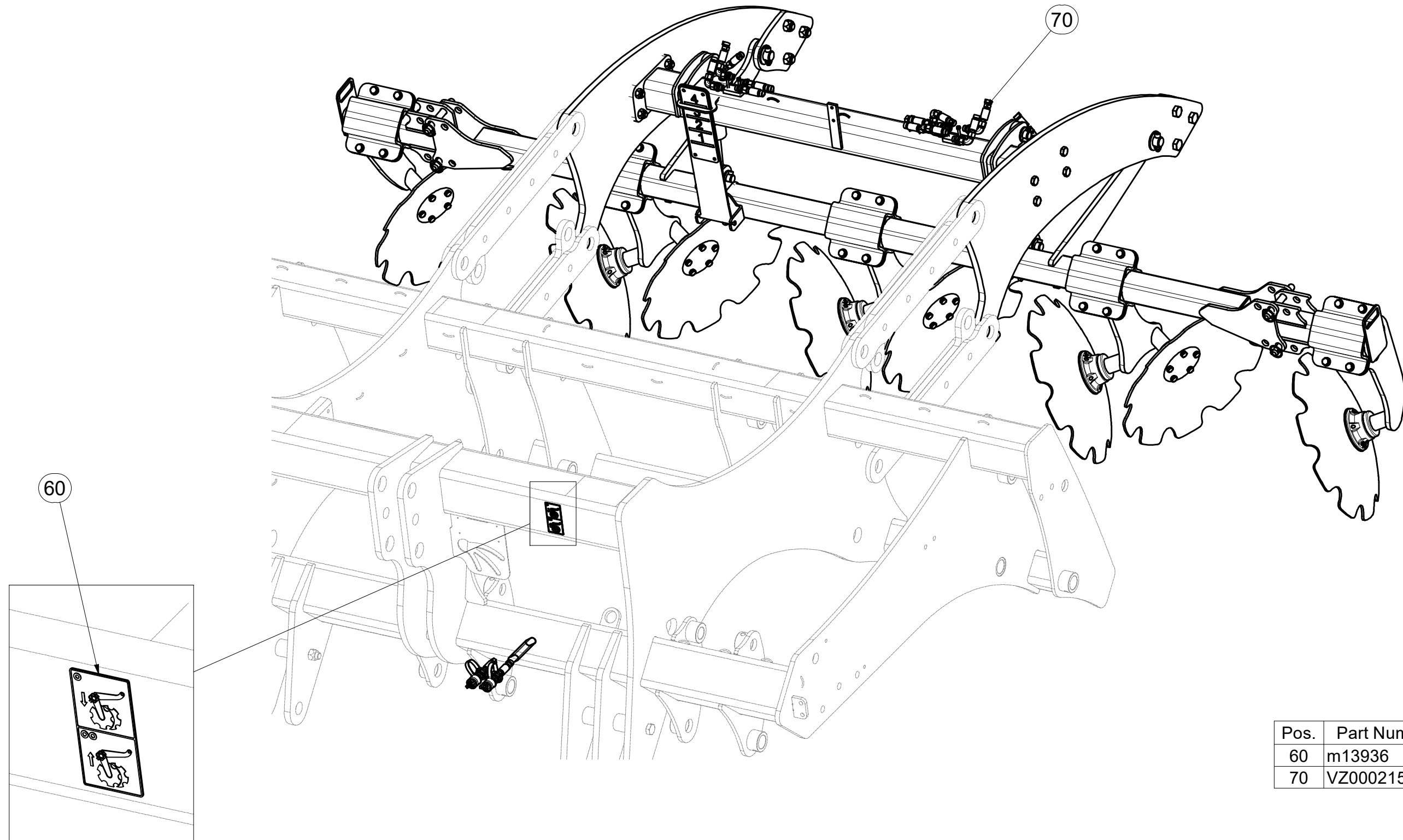

Pos.	Part Number	Pcs.
60	m13936	1
70	VZ00021582	1

CZ SADA DISKŮ
 D SCHEIBENSATZ
 F KIT DE DISQUES

GB DISC SET
 RU КОМПЛЕКТ ДИСКОВ
 PL ZESTAW TALERZY



VZ00010948

Pos.	Part Number	Pcs.	Pos.	Part Number	Pcs.
1	4017181	1	33	m05647	6
2	4017180	1	35	m14143	4
3	4010900	2	40	m14029	4
4	VZ00021614	1	42	4019156	4
5	VZ00021615	1	50	m03775	4
6	3005491	2	51	m13846	8
20	4007584	2	52	m11169	6
22	m08386	4	55	m10454	4
32	m10112	8			

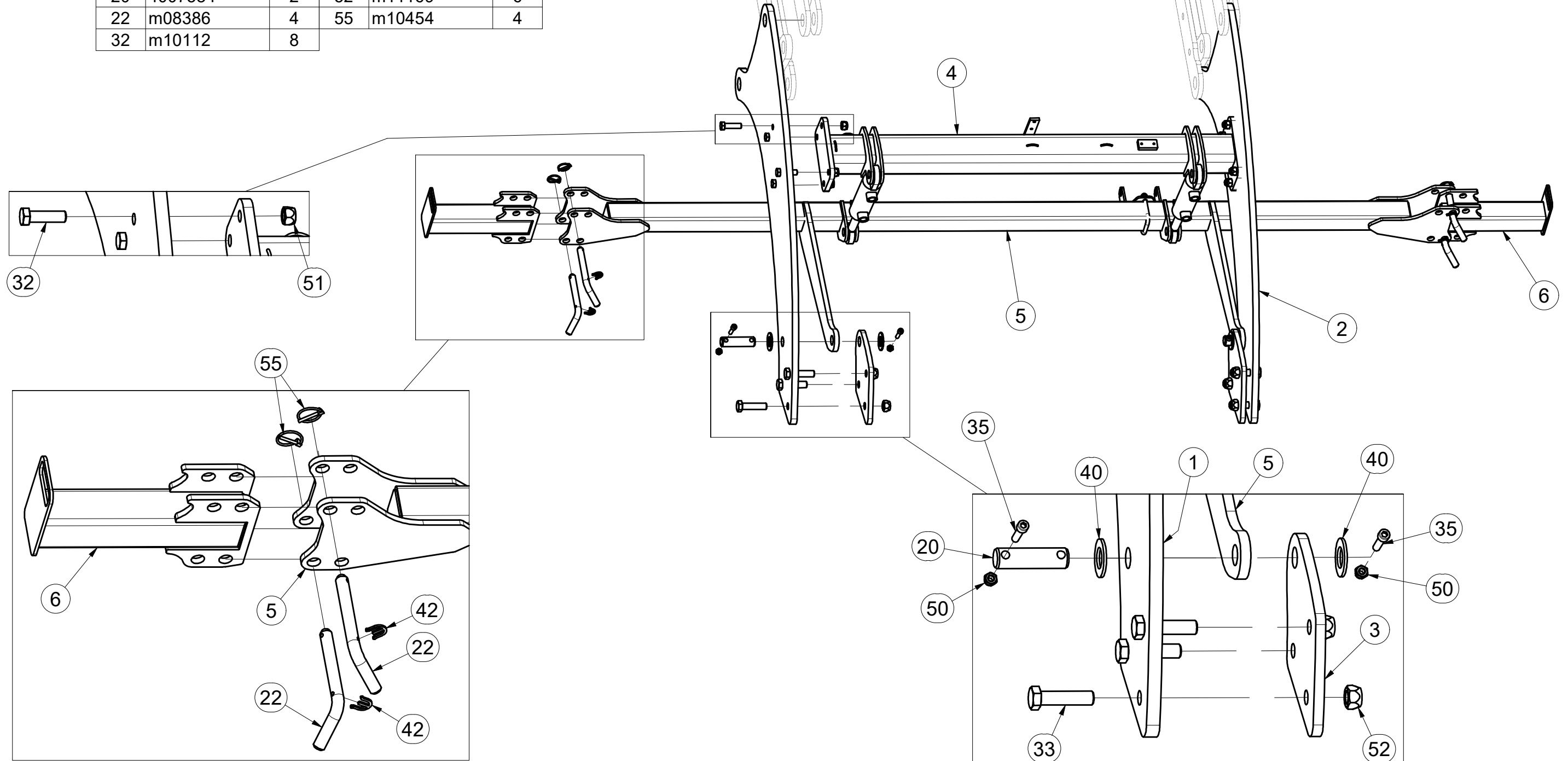
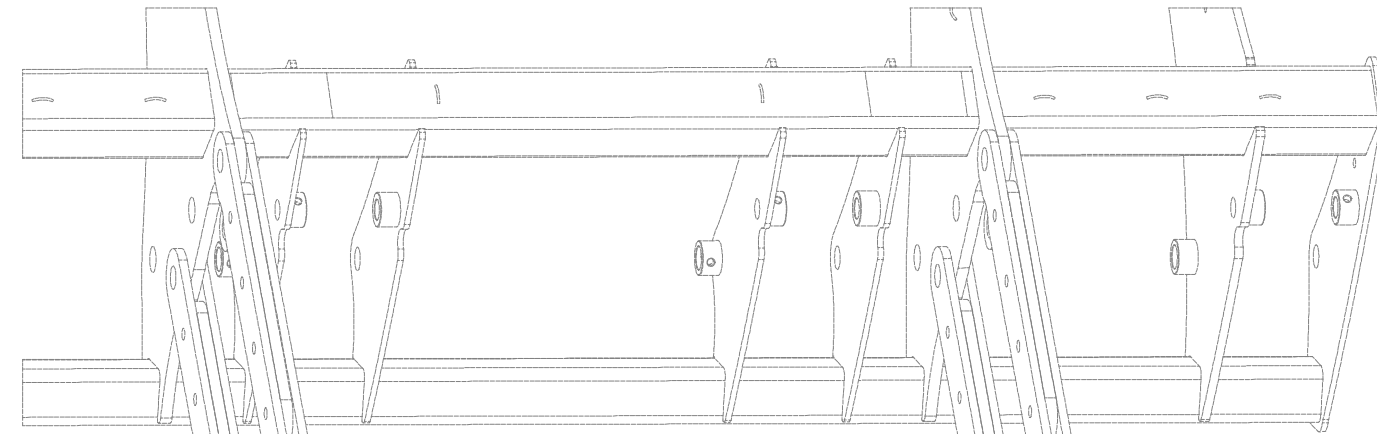

CZ SADA DISKŮ
 D SCHEIBENSATZ
 F KIT DE DISQUES

GB DISC SET
 RU КОМПЛЕКТ ДИСКОВ
 PL ZESTAW TALERZY



VZ00010948

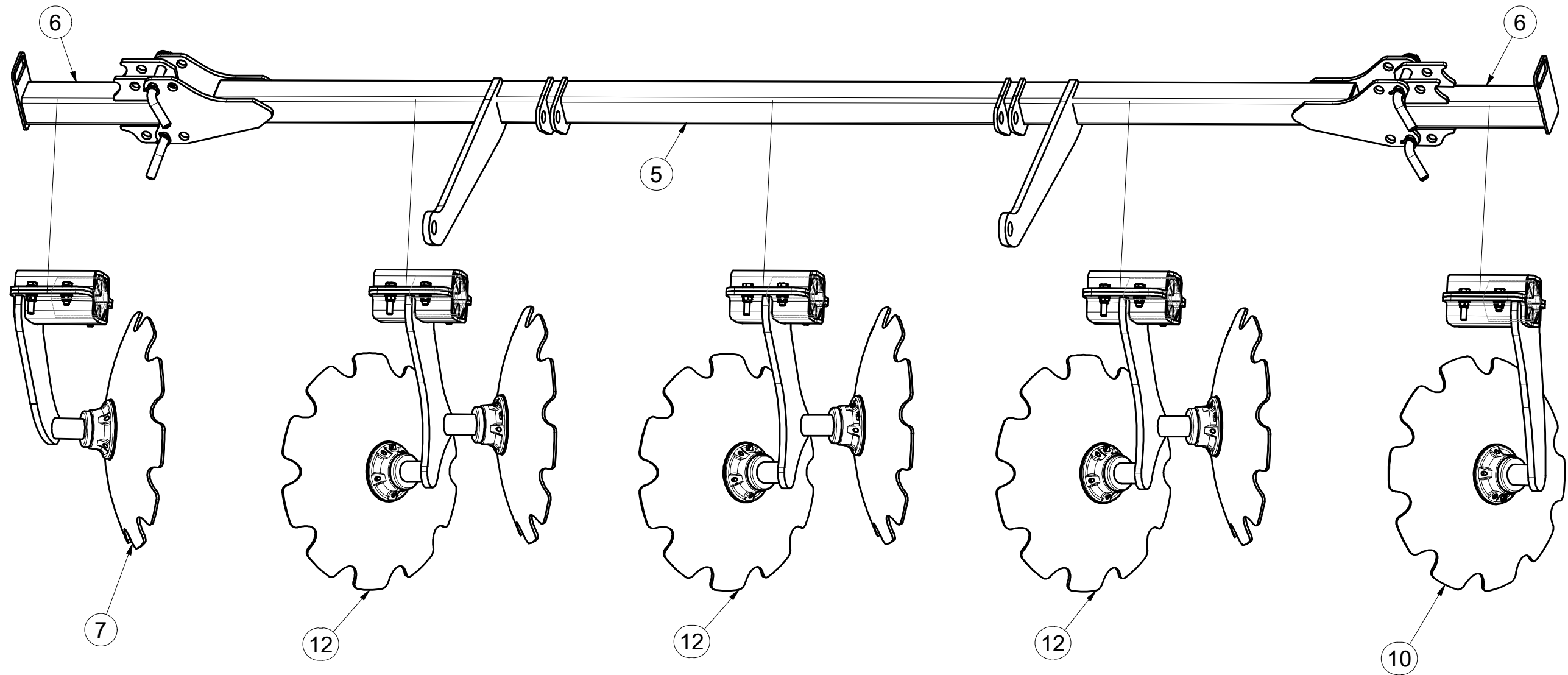

Pos.	Part Number	Pcs.
5	VZ00021615	1
6	3005491	2
7	VZ00010889	1
10	VZ00010887	1
12	VZ00010888	3

CZ SADA DISKŮ
 D SCHEIBENSATZ
 F KIT DE DISQUES

GB DISC SET
 RU КОМПЛЕКТ ДИСКОВ
 PL ZESTAW TALERZY



VZ00010948

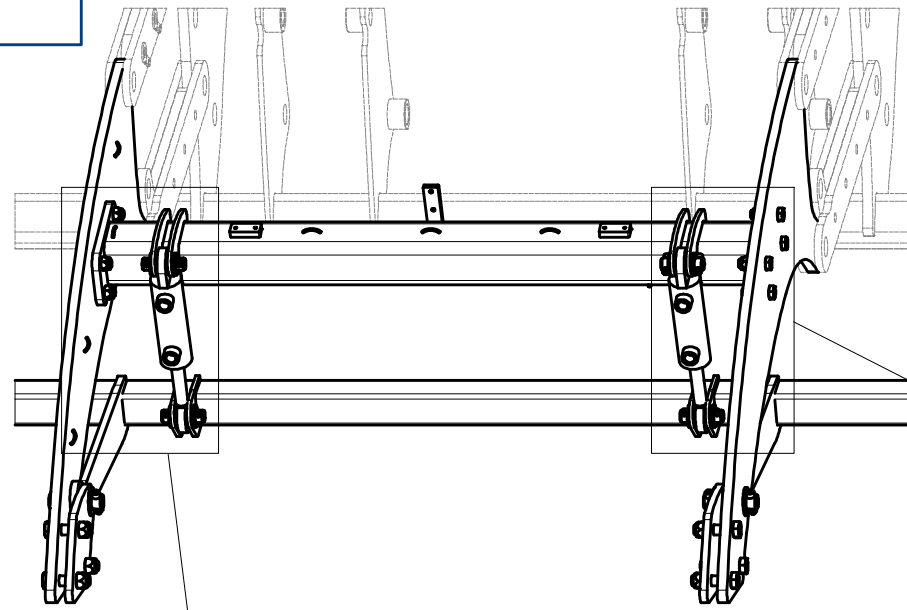

Pos.	Part Number	Pcs.
21	4010390	4
34	m09464	8
41	m14028	8
53	m04503	8
65	VZ00014803	2

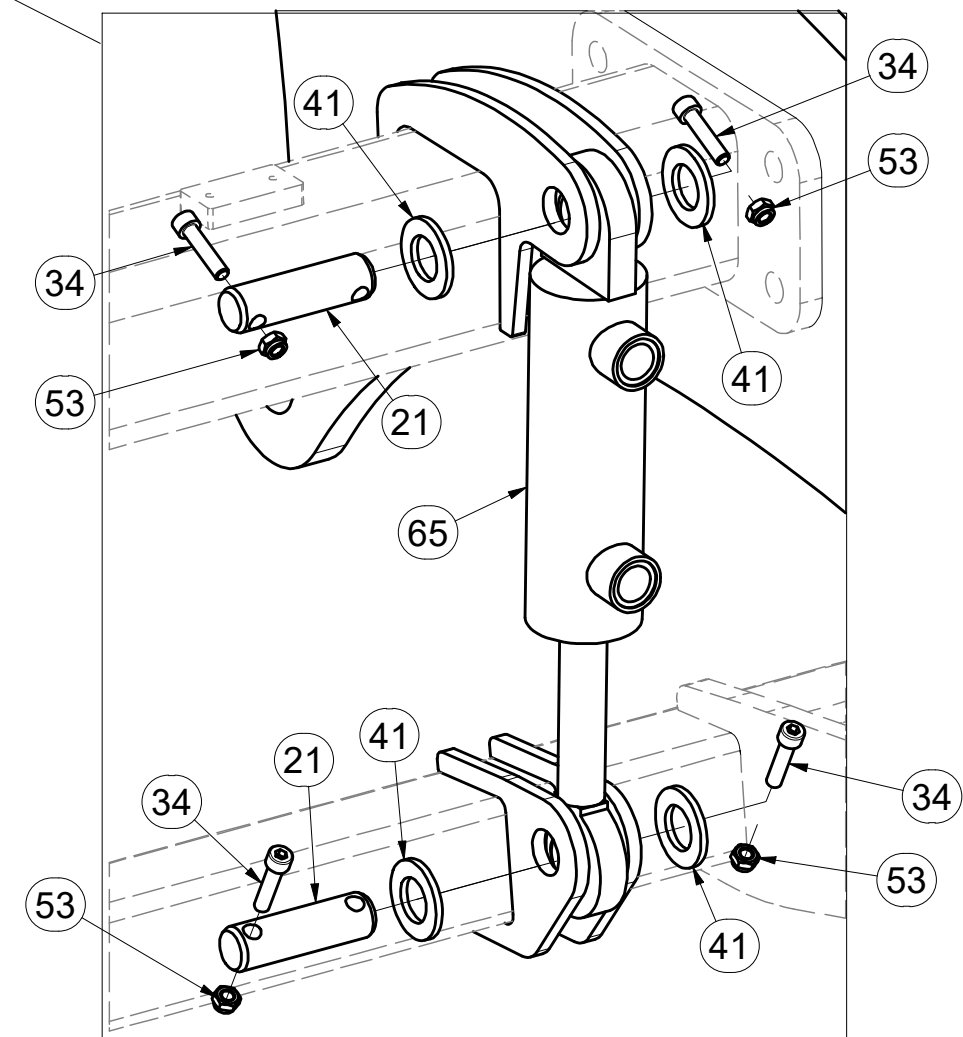
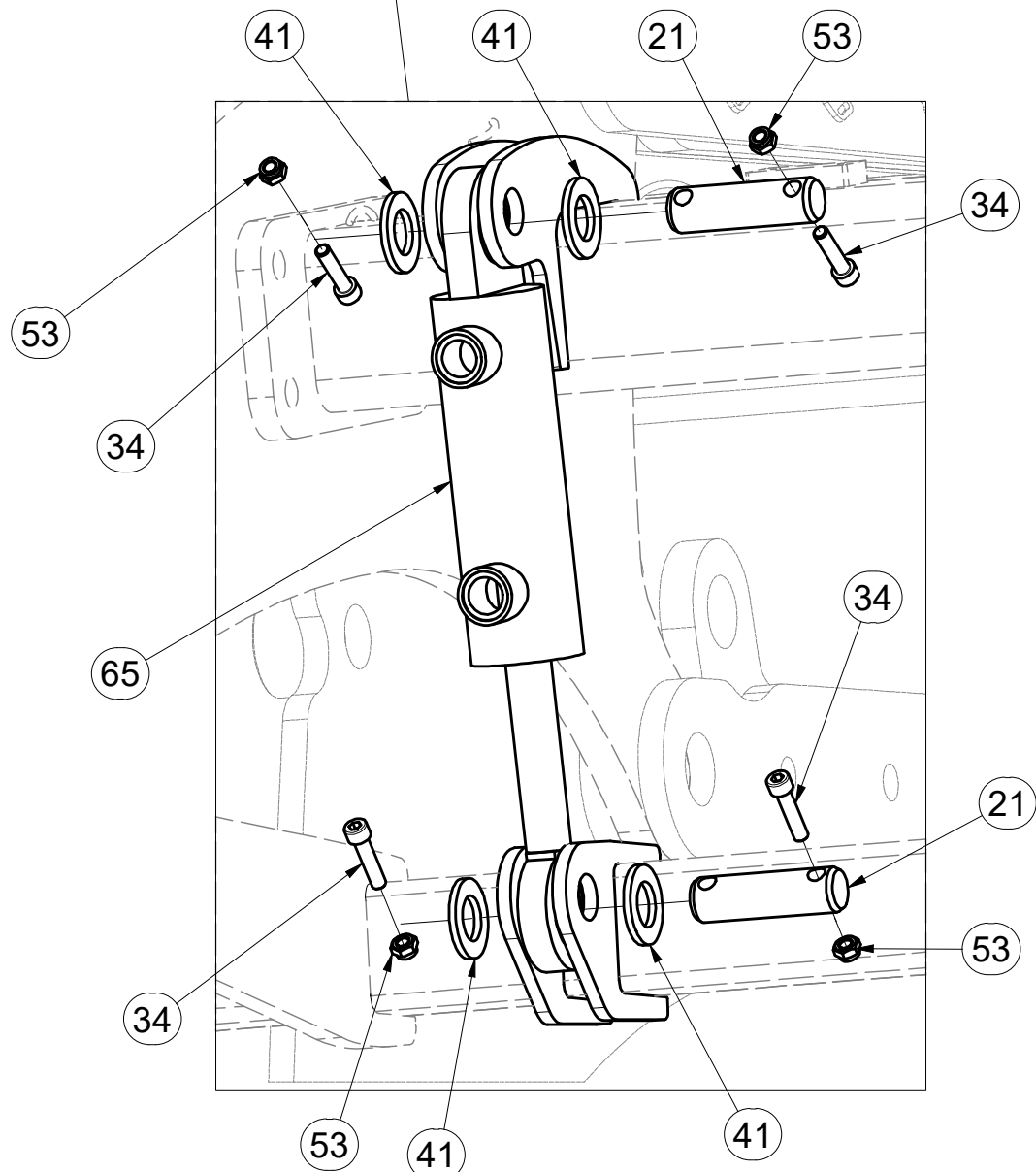

- Ⓒ SADA DISKŮ
- Ⓓ SCHEIBENSATZ
- Ⓕ KIT DE DISQUES

- Ⓒ DISC SET
- Ⓓ КОМПЛЕКТ ДИСКОВ
- Ⓕ ZESTAW TALERZY



VZ00010948

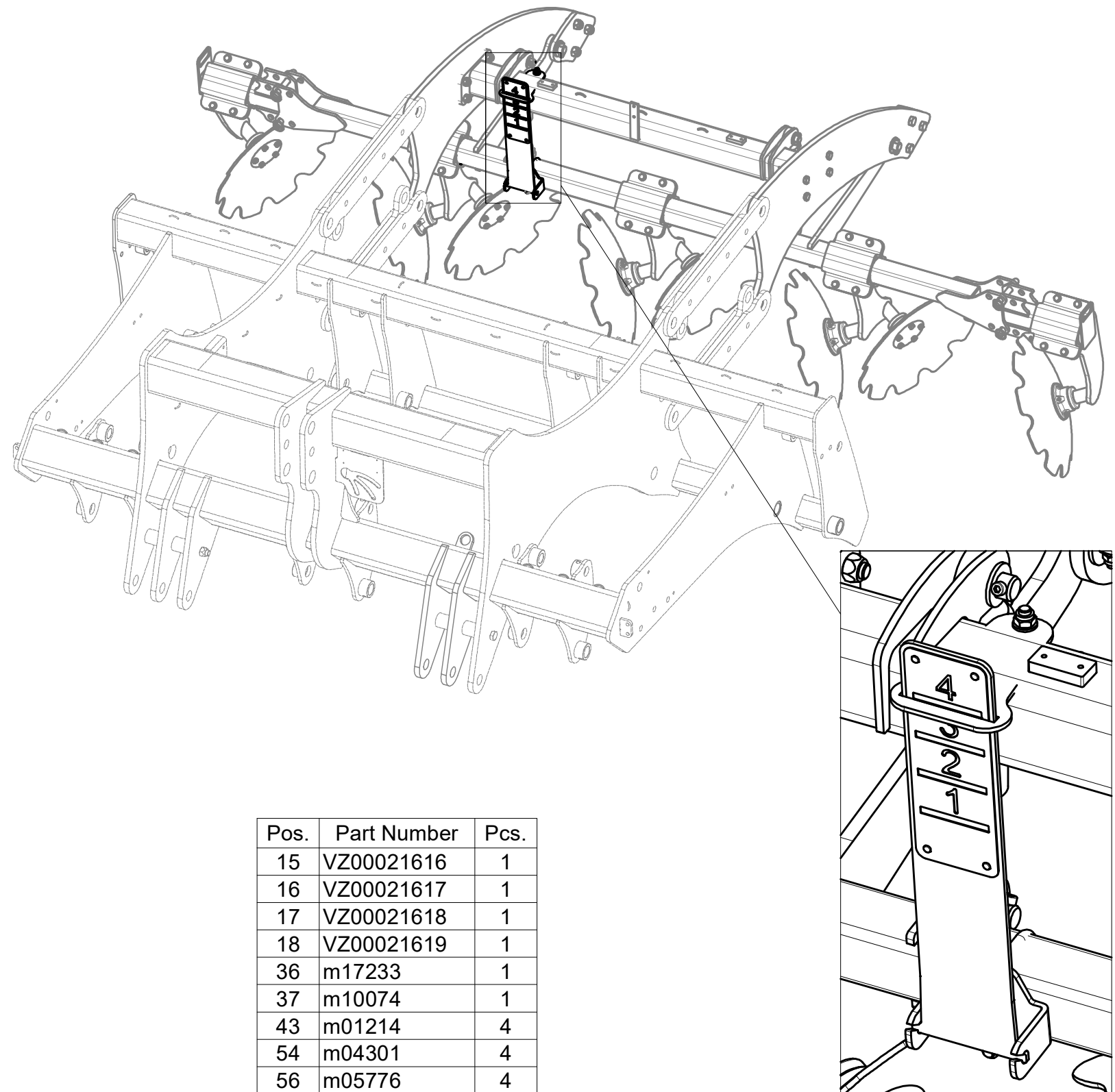
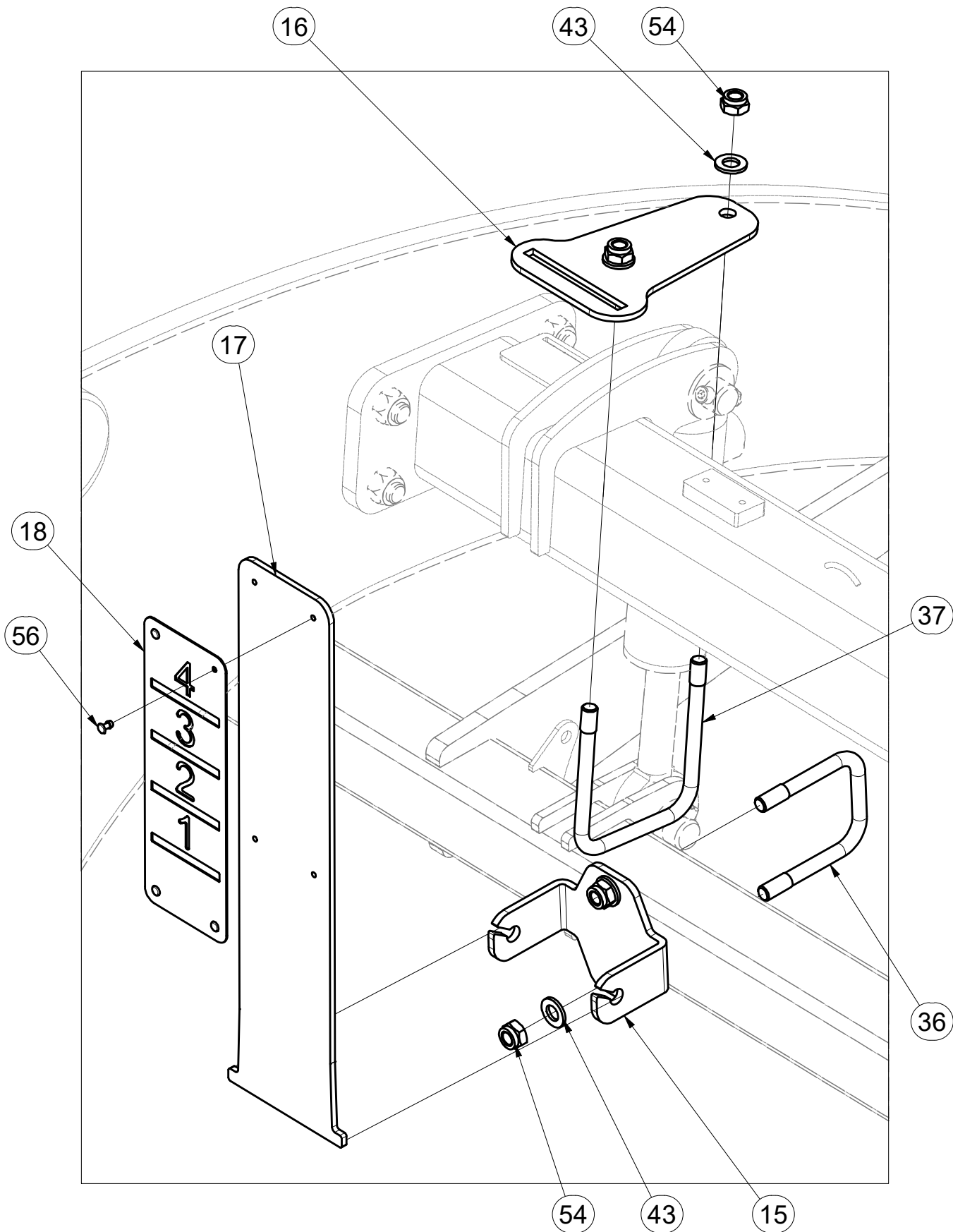

Pos.	Part Number	Pcs.
15	VZ00021616	1
16	VZ00021617	1
17	VZ00021618	1
18	VZ00021619	1
36	m17233	1
37	m10074	1
43	m01214	4
54	m04301	4
56	m05776	4

(CZ) DISK PRAVÝ
 (D) SCHEIBE, RECHTE
 (F) DISQUE DROITE

(GB) RIGHT DISC
 (RU) ДИСК ПРАВЫЙ
 (PL) TALERZ PRAWY



VZ00010887

Pos.	Part Number	Pcs.	Pos.	Part Number	Pcs.
1	3008422	1	13	m03705	1
2	9004269	1	14	m04250	1
3	VZ00010824	4	20	m00120	5
5	3008166	1	21	m07963	2
6	3009533	1	22	m03926	2
10	m14552	1	30	m01208	5
11	m11160	2	31	m01214	8
12	m11159	1	35	m12134	4

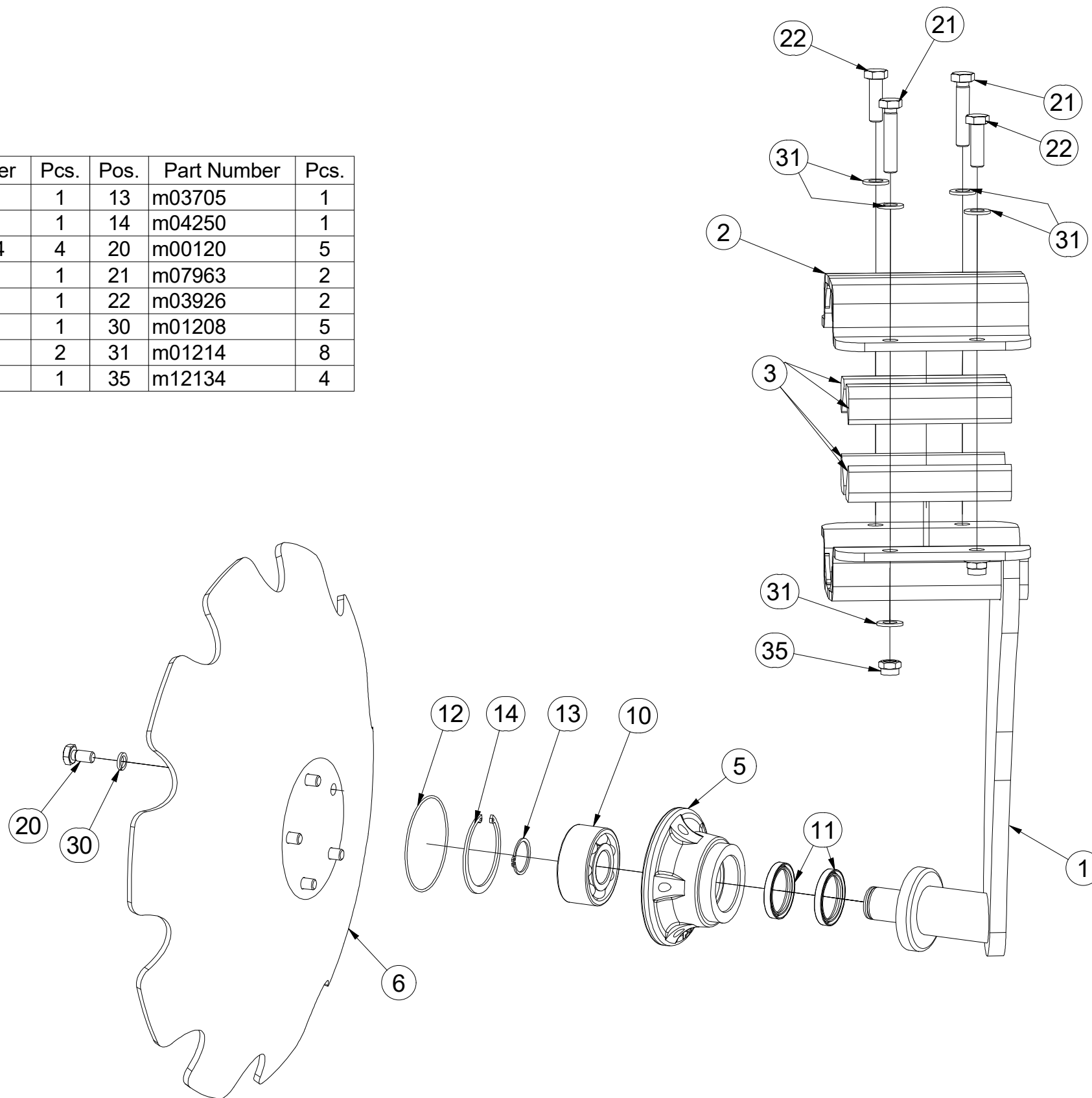

Ⓒ DVOJDISK

Ⓓ DUPLEXSCHEIBE

Ⓕ DISQUE DOUBLE

VZ00010888

Ⓖ TWIN DISC

Ⓡ ДВОЙНОЙ ДИСК

Ⓟ TALERZ PODWÓJNY



Pos.	Part Number	Pcs.	Pos.	Part Number	Pcs.
1	3008423	1	13	m03705	2
2	9004269	1	14	m04250	2
3	VZ00010824	4	20	m00120	10
5	3008166	2	21	m07963	2
6	3009533	2	22	m03926	2
10	m14552	2	30	m01208	10
11	m11160	4	31	m01214	8
12	m11159	2	35	m12134	4

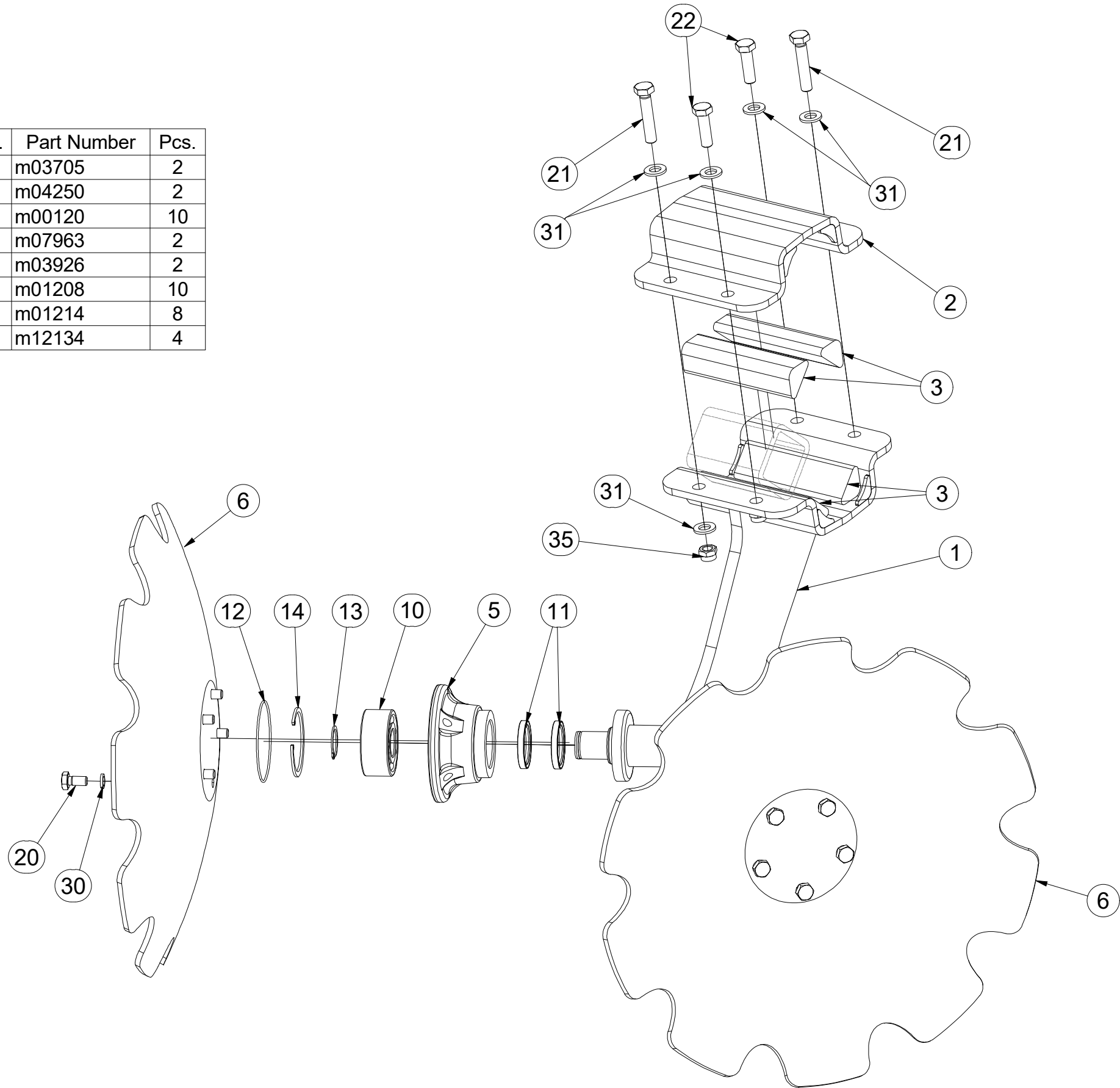

(CZ) DISK LEVÝ
 (D) SCHEIBE, LINKE
 (F) DISQUE GAUCHE

(GB) LEFT DISC
 (RU) ДИСК ЛЕВЫЙ
 (PL) TALERZ LEWY



VZ00010889

Pos.	Part Number	Pcs.	Pos.	Part Number	Pcs.
1	3008421	1	13	m03705	1
2	9004269	1	14	m04250	1
3	VZ00010824	4	20	m00120	5
5	3008166	1	21	m07963	2
6	3009533	1	22	m03926	2
10	m14552	1	30	m01208	5
11	m11160	2	31	m01214	8
12	m11159	1	35	m12134	4

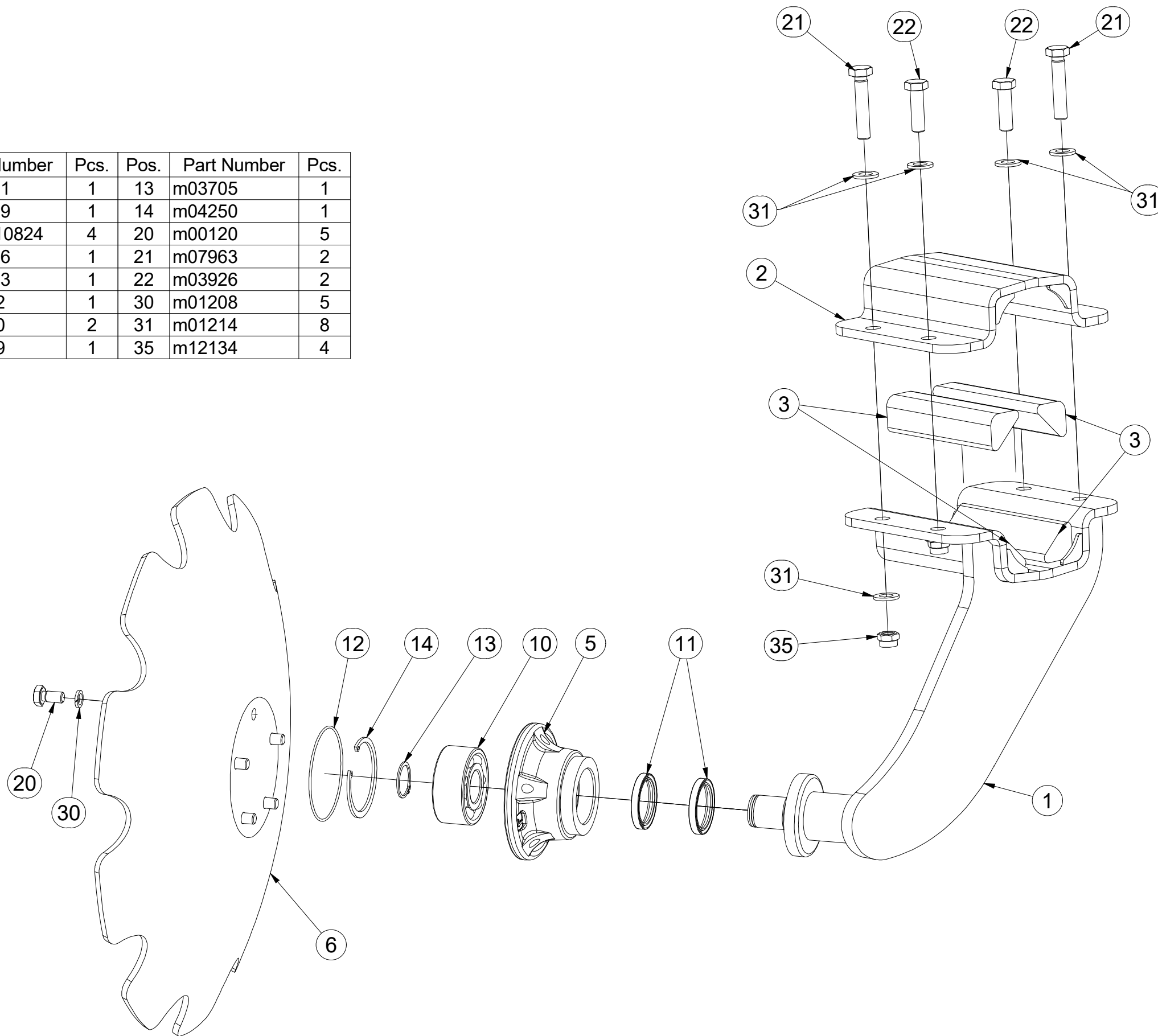

- Ⓒ SADA ZADNÍCH VÁLCŮ
- Ⓓ SATZ HINTERE WALZEN
- Ⓕ KIT DE ROULEAUX ARRIÈRE

VZ00012161

- Ⓖ SET OF REAR ROLLERS
- Ⓡ КОМПЛЕКТ ЗАДНИХ КАТКОВ
- Ⓟ ZESTAW TYLNYCH WAŁÓW

Farmet

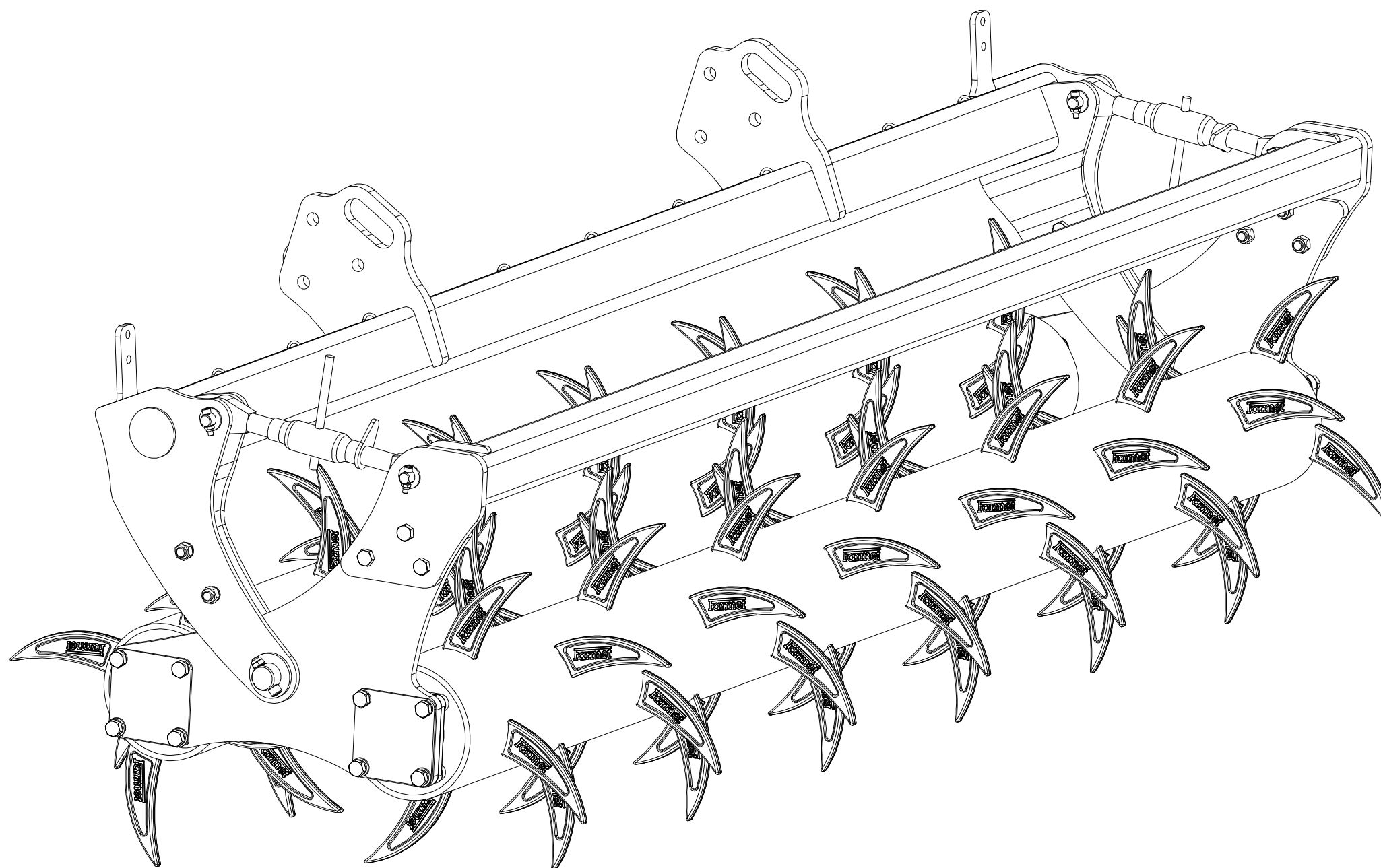

CZ SADA ZADNÍCH VÁLCŮ
 D SATZ HINTERE WALZEN
 F KIT DE ROULEAUX ARRIÈRE

GB SET OF REAR ROLLERS
 RU КОМПЛЕКТ ЗАДНИХ КАТКОВ
 PL ZESTAW TYLNYCH WAŁÓW



VZ00012161

Pos.	Part Number	Pcs.
1	VZ00012162	1
2	3005518	1
3	4017166	2
5	4010987	2
15	4014575	4
16	4014576	2
31	m10849	6
32	m09464	8
33	m14008	2
41	m03175	2
42	m14030	8
50	m04301	2
51	m04503	8
52	m13846	6

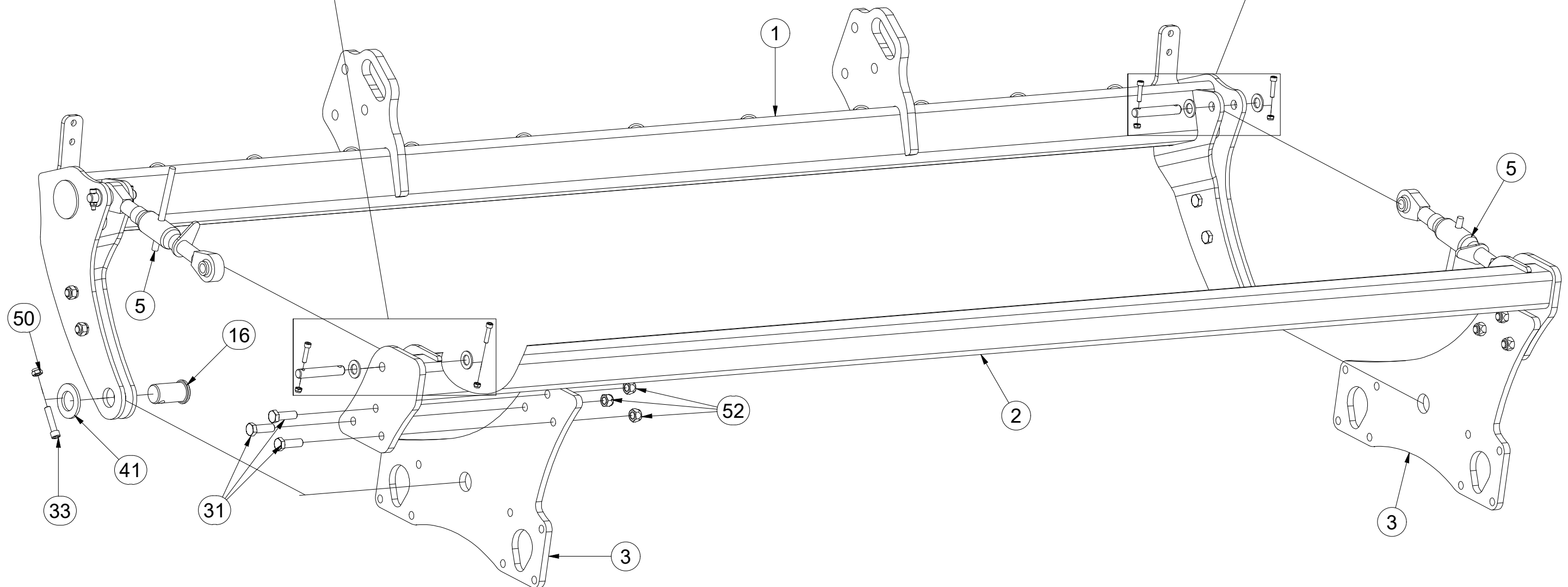
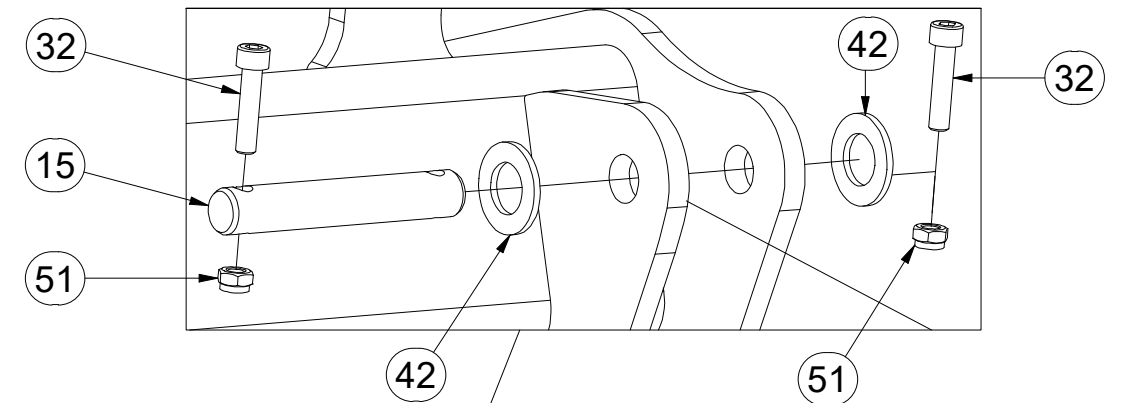
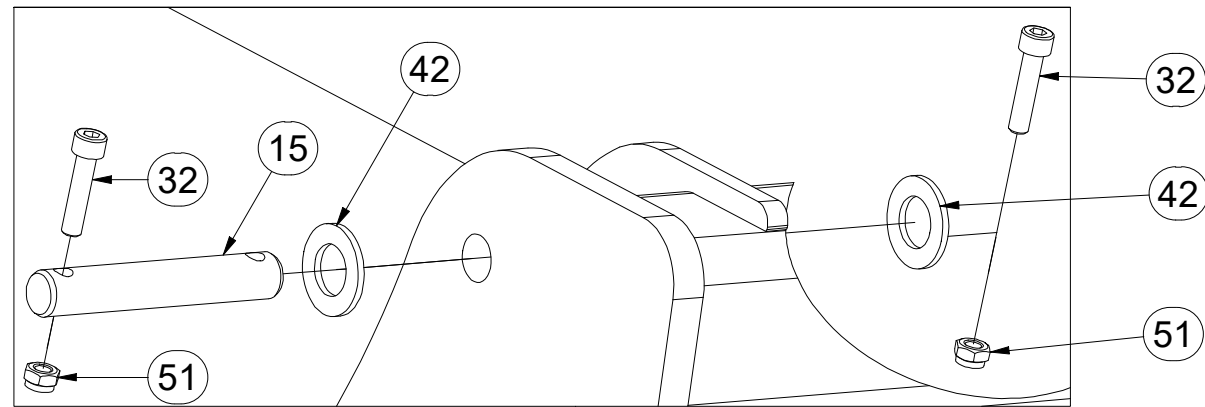

- Ⓒ SADA ZADNÍCH VÁLČŮ
- Ⓓ SATZ HINTERE WALZEN
- Ⓕ KIT DE ROULEAUX ARRIÈRE

- Ⓖ SET OF REAR ROLLERS
- Ⓡ КОМПЛЕКТ ЗАДНИХ КАТКОВ
- Ⓟ ZESTAW TYLNYCH WAŁÓW



VZ00012161

Pos.	Part Number	Pcs.
10	VZ00008333	2
20	m21967	4
21	4017163	8
22	4019073	8
24	4019071	4
25	4019072	4
30	m00619	16
34	m17638	8
40	m01219	8
43	m01208	8
44	m02157	16

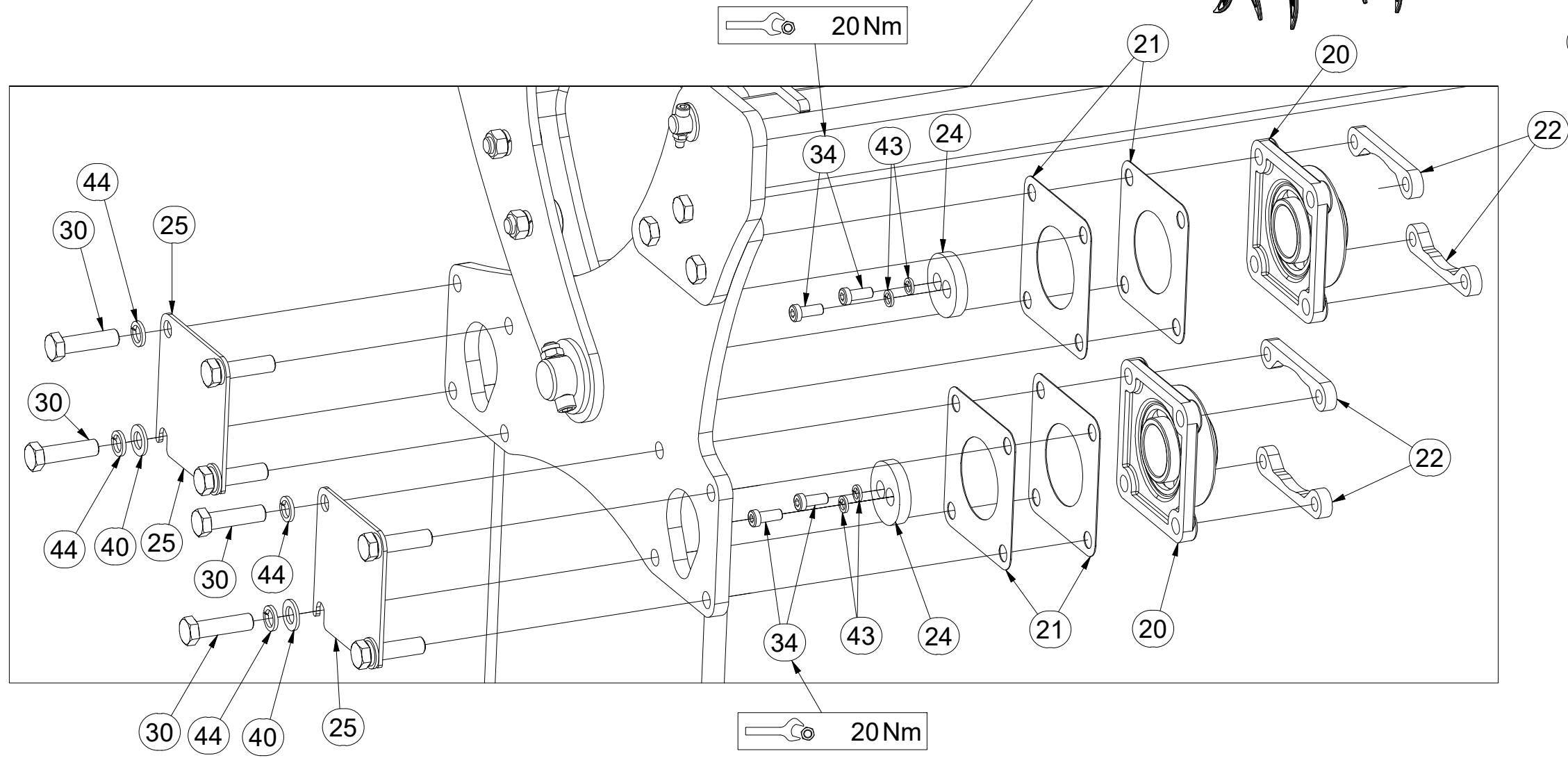
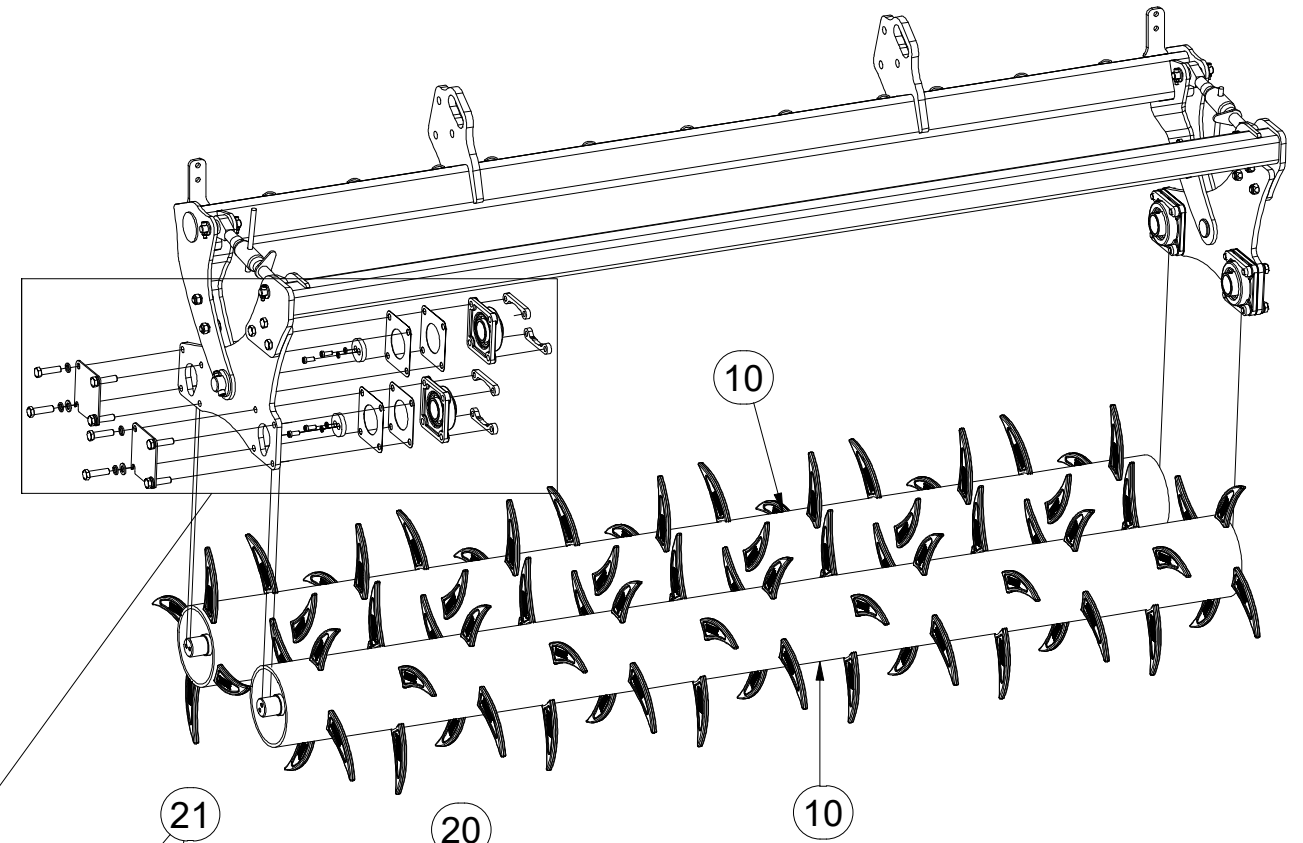

Ⓒ NAPÍNACÍ MATICE

Ⓓ SPANNMUTTER

Ⓕ ÉCROU TENDEUR

Ⓖ TURNBUCKLE

Ⓡ НАТЯЖНАЯ ГАЙКА

Ⓢ NAKRĘTKA NAPINAJĄCA

Farmet

4010987

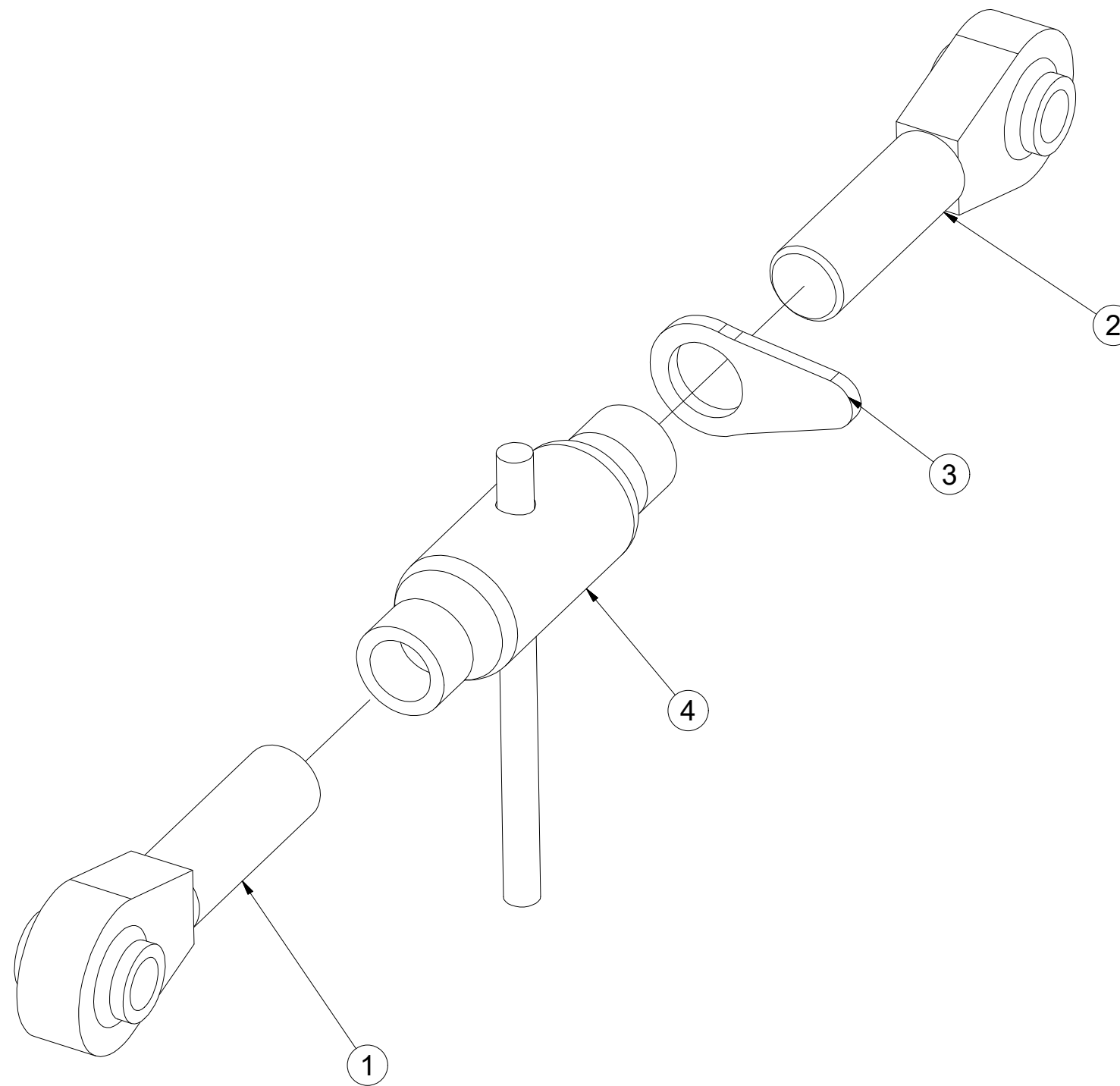
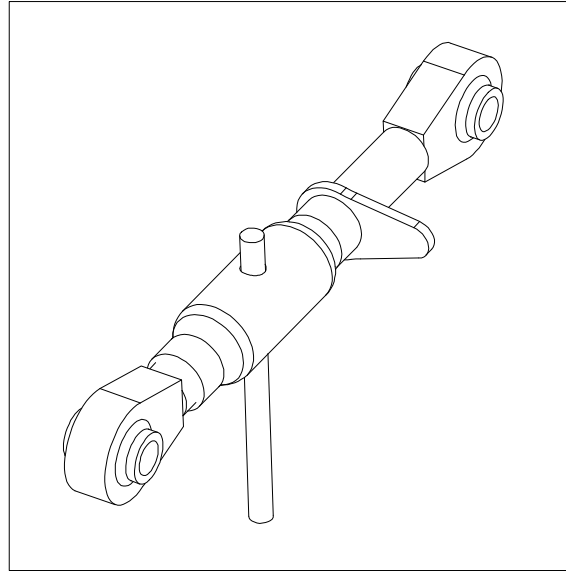

Pos.	Part Number	Pcs.
1	4010986	1
2	4010985	1
3	m13077	1
4	m13074	1

- Ⓒ SADA ZADNÍCH VÁLCŮ
- Ⓓ SATZ HINTERE WALZEN
- Ⓕ KIT DE ROULEAUX ARRIÈRE

- Ⓖ SET OF REAR ROLLERS
- Ⓡ КОМПЛЕКТ ЗАДНИХ КАТКОВ
- Ⓟ ZESTAW TYLNYCH WAŁÓW



3012100

Pos.	Part Number	Pcs.
1	3010907	1
5	3010939	1
42	m01133	8
52	m02157	8
53	m01219	8

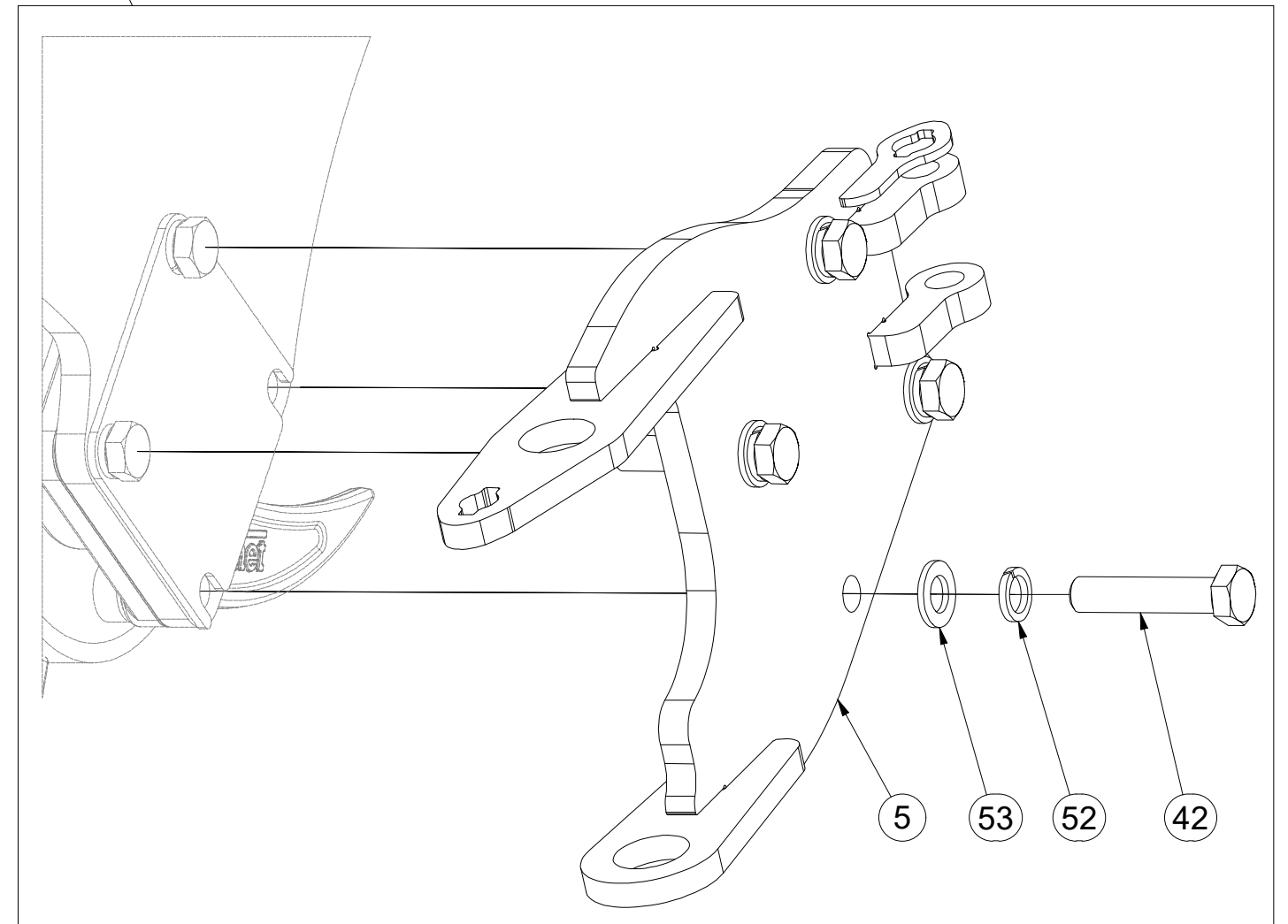
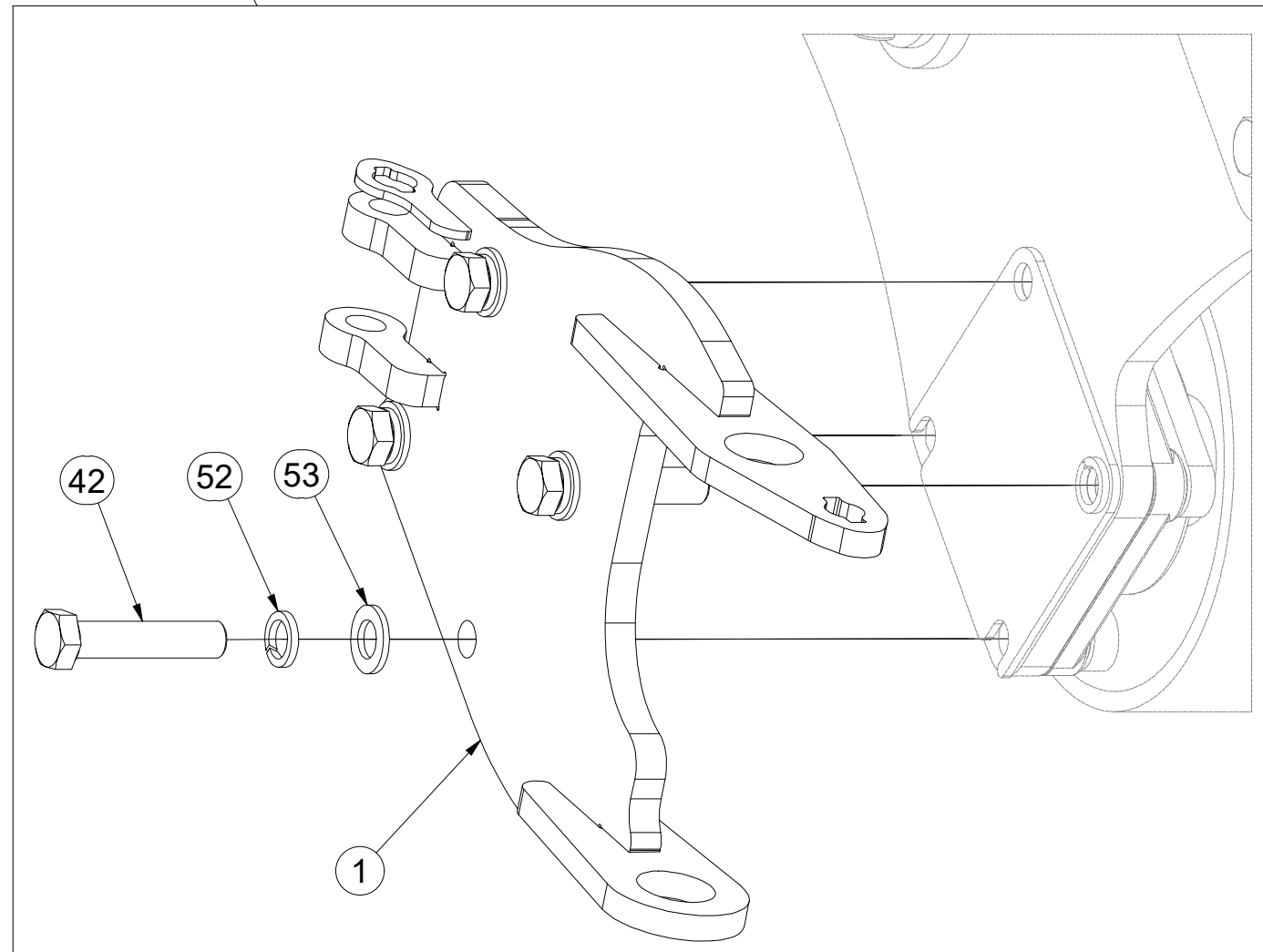
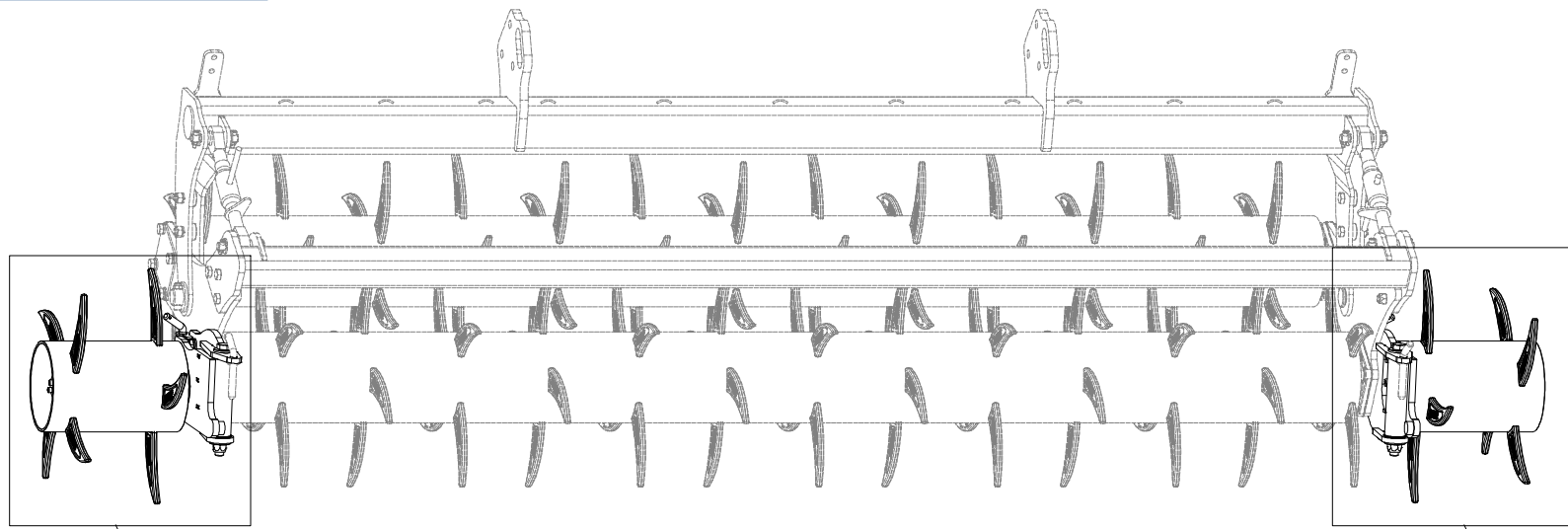

- Ⓒ SADA ZADNÍCH VÁLČŮ
- Ⓓ SATZ HINTERE WALZEN
- Ⓕ KIT DE ROULEAUX ARRIÈRE

- Ⓖ SET OF REAR ROLLERS
- Ⓡ КОМПЛЕКТ ЗАДНИХ КАТКОВ
- Ⓟ ZESTAW TYLNYCH WAŁÓW



3012100

Pos.	Part Number	Pcs.	Pos.	Part Number	Pcs.
2	3012083	1	40	m09870	4
10	3012090	2	41	m18599	8
11	4025003	2	43	m17547	2
15	m14766	4	50	m01202	4
16	4021707	8	51	m17545	8
20	VZ00019773	2	54	m02866	2
25	m21654	4	60	m01305	8
26	m12337	4	61	m11169	2
30	4021419	2	62	m08036	2
31	m11505	2			

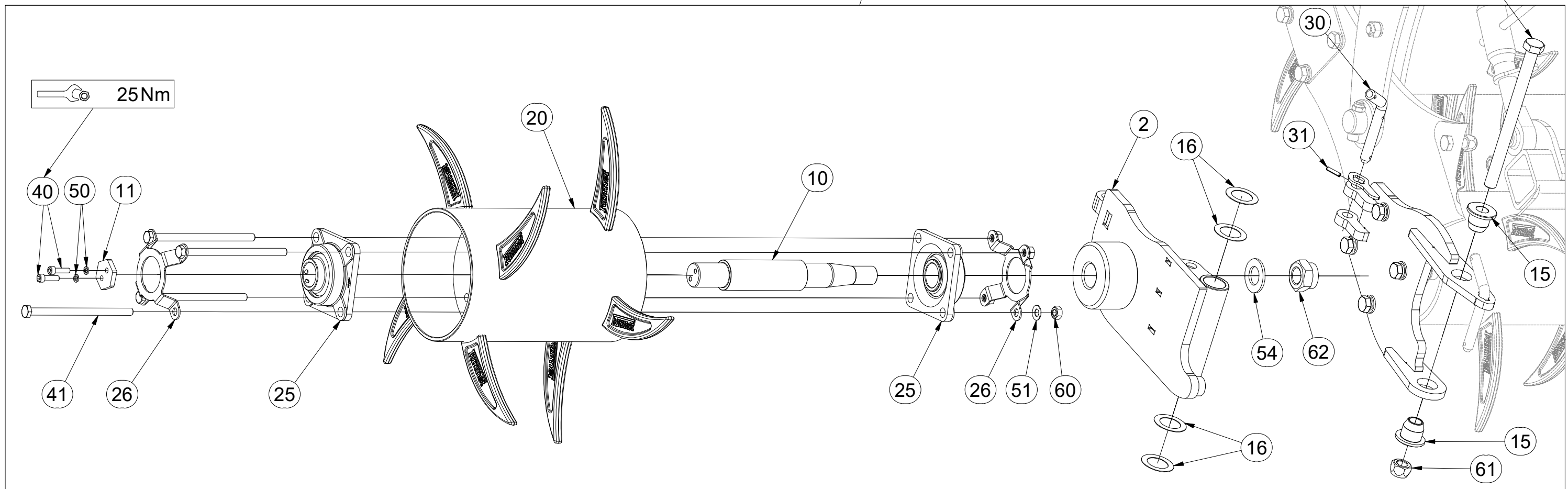
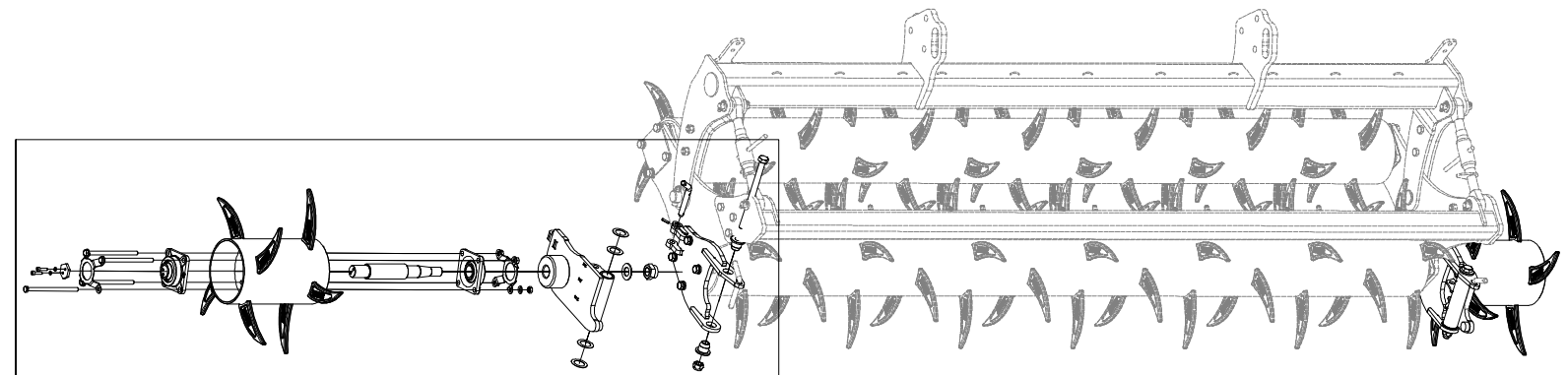

- Ⓒ SADA ZADNÍCH VÁLCŮ
- Ⓓ SATZ HINTERE WALZEN
- Ⓕ KIT DE ROULEAUX ARRIÈRE

- Ⓖ SET OF REAR ROLLERS
- Ⓡ КОМПЛЕКТ ЗАДНИХ КАТКОВ
- Ⓟ ZESTAW TYLNYCH WAŁÓW



3012100

Pos.	Part Number	Pcs.	Pos.	Part Number	Pcs.
6	3012099	1	40	m09870	4
10	3012090	2	41	m18599	8
11	4025003	2	43	m17547	2
15	m14766	4	50	m01202	4
16	4021707	8	51	m17545	8
20	VZ00019773	2	54	m02866	2
25	m21654	4	60	m01305	8
26	m12337	4	61	m11169	2
30	4021419	2	62	m08036	2
31	m11505	2			

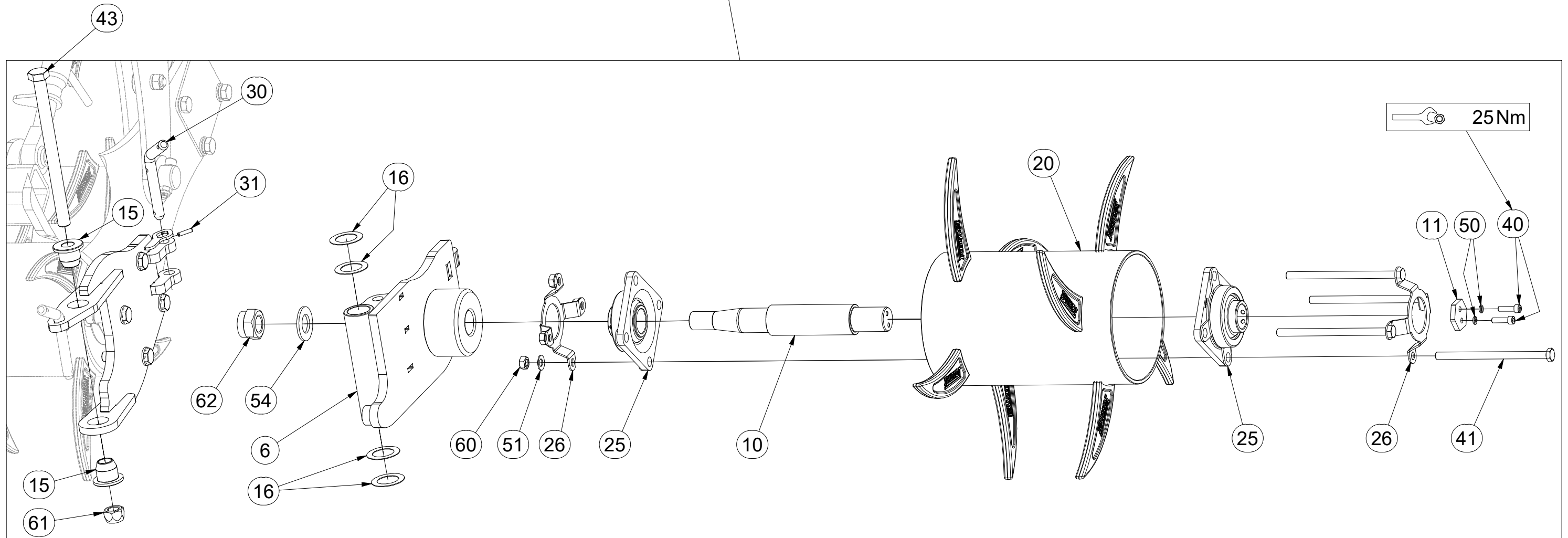
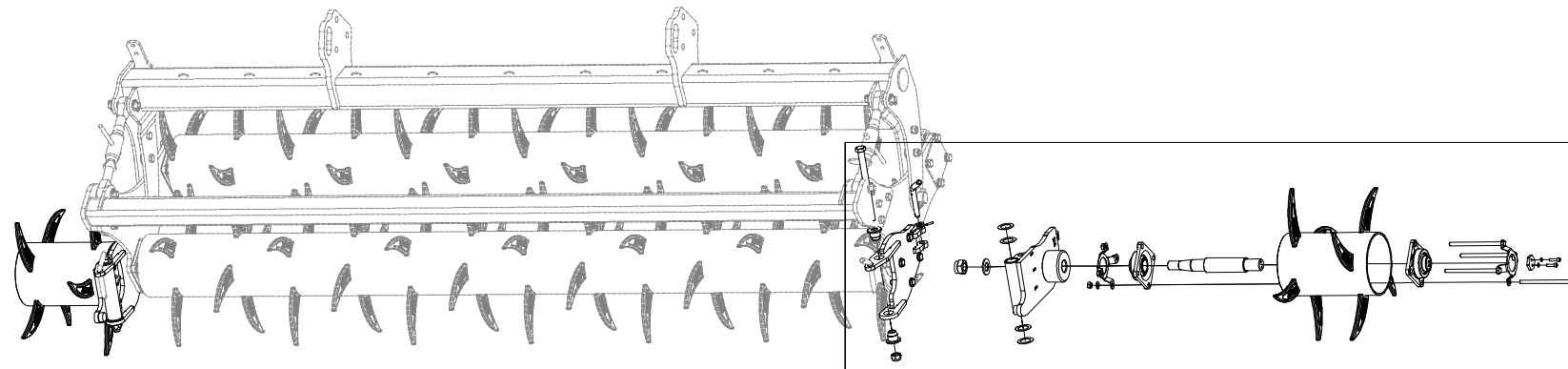

- ⒸZ TERČE
- Ⓓ SCHEIBE
- Ⓕ CIBLES

- ⒼB DISCS
- ⒺЩИТКИ
- ⒽL TARCZE



3009540

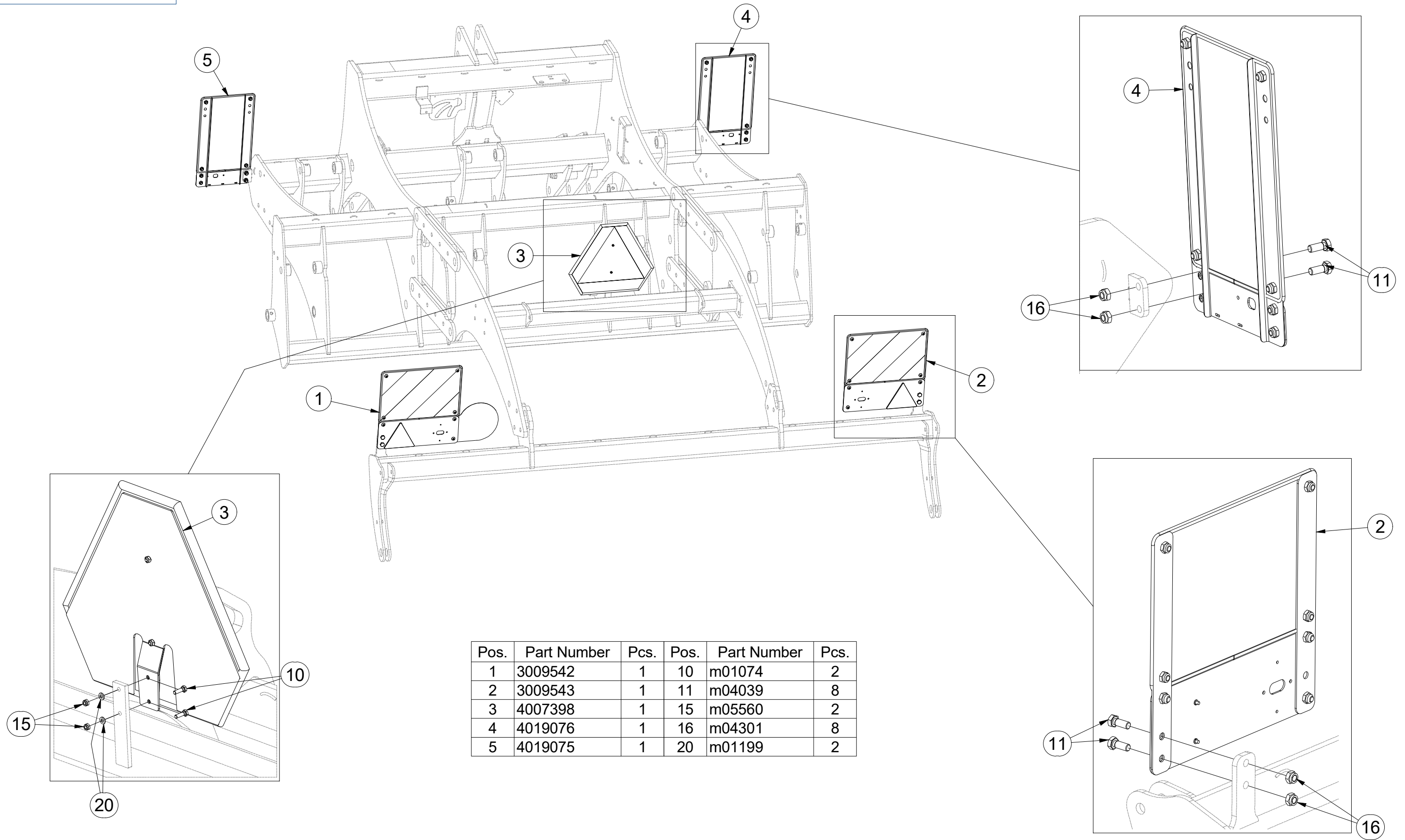

Pos.	Part Number	Pcs.	Pos.	Part Number	Pcs.
1	3009542	1	10	m01074	2
2	3009543	1	11	m04039	8
3	4007398	1	15	m05560	2
4	4019076	1	16	m04301	8
5	4019075	1	20	m01199	2

ⒸZ TERČ PŘEDNÍ LEVÝ

Ⓓ SCHILD, VORDERES, LINKES

Ⓕ CIBLE AVANT GAUCHE

ⒸB LEFT FRONT DISC

ⒸU ЩИТОК ПЕРЕДНИЙ ЛЕВЫЙ

ⒸL TARCZA PRZEDNIA LEWA



4019075

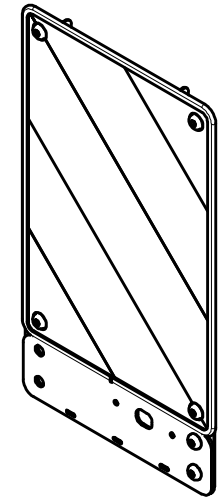
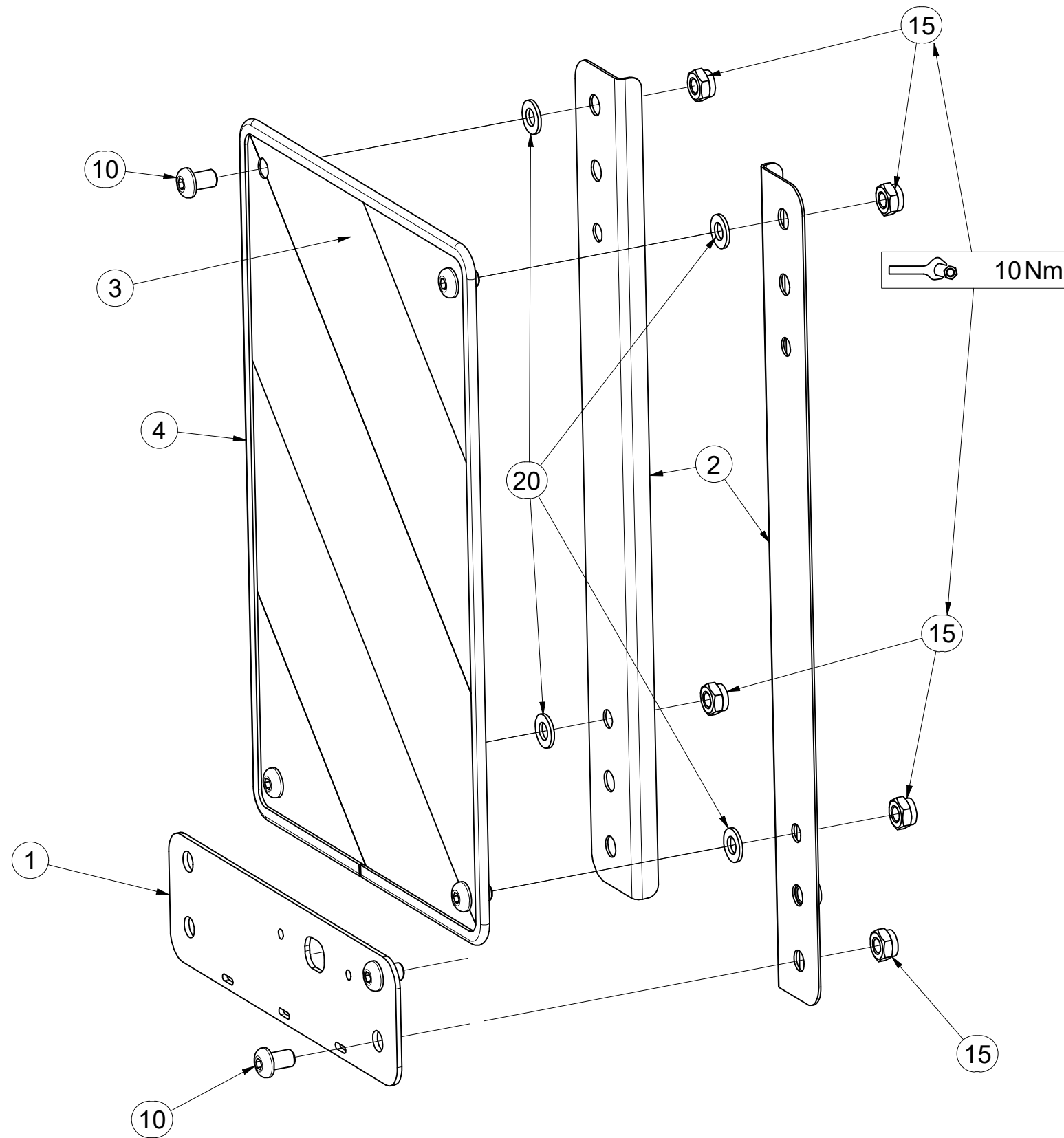

Pos.	Part Number	Pcs.
1	4019247	1
2	4019245	2
3	m17941	1
4	m16628	1,4
10	m16687	6
15	m03775	6
20	m01209	4

ⒸZ TERČ PŘEDNÍ PRAVÝ

Ⓓ SCHILD, VORDERES, RECHTES

Ⓕ CIBLE AVANT DROITE

ⒸB RIGHT FRONT DISC

ⒸU ЩИТОК ПЕРЕДНИЙ ПРАВЫЙ

ⒸL TARCZA PRZEDNIA PRAWA



4019076

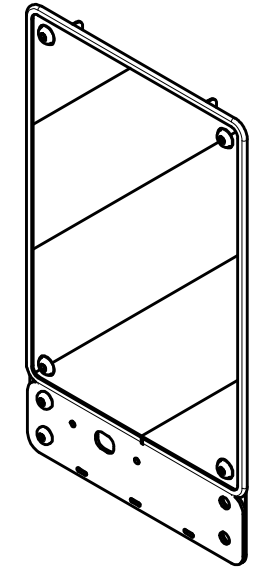
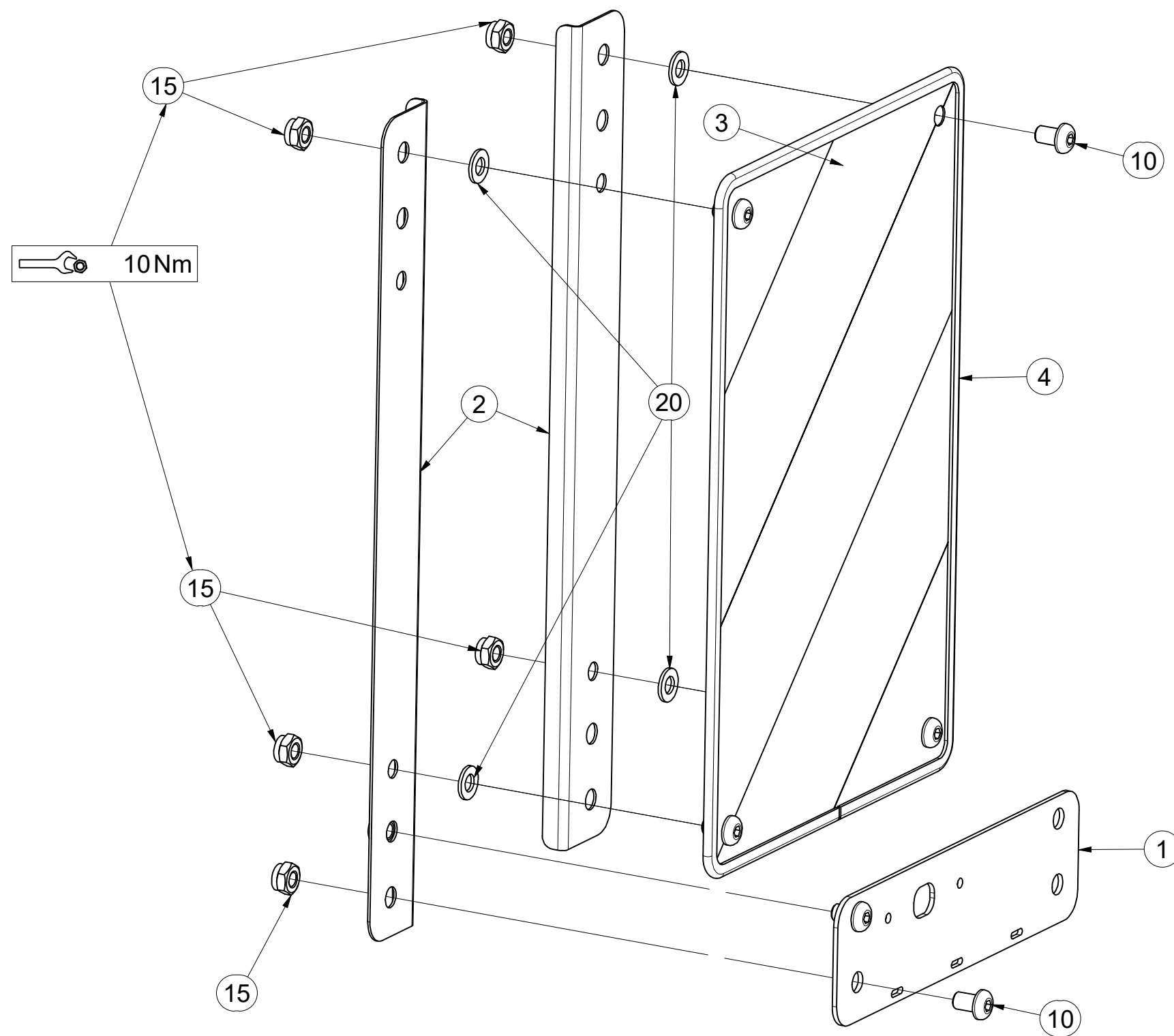

Pos.	Part Number	Pcs.
1	4019247	1
2	4019245	2
3	m17940	1
4	m16628	1,4
10	m16687	6
15	m03775	6
20	m01209	4

ⒸZ TERČ ZADNÍ LEVÝ

Ⓓ SCHILD, HINTERES, LINKES

Ⓕ CIBLE ARRIÈRE GAUCHE

ⒸB LEFT REAR DISC

ⒸU ЩИТОК ЗАДНИЙ ЛЕВЫЙ

ⒸL TARCZA TYLNA LEWA



3009542

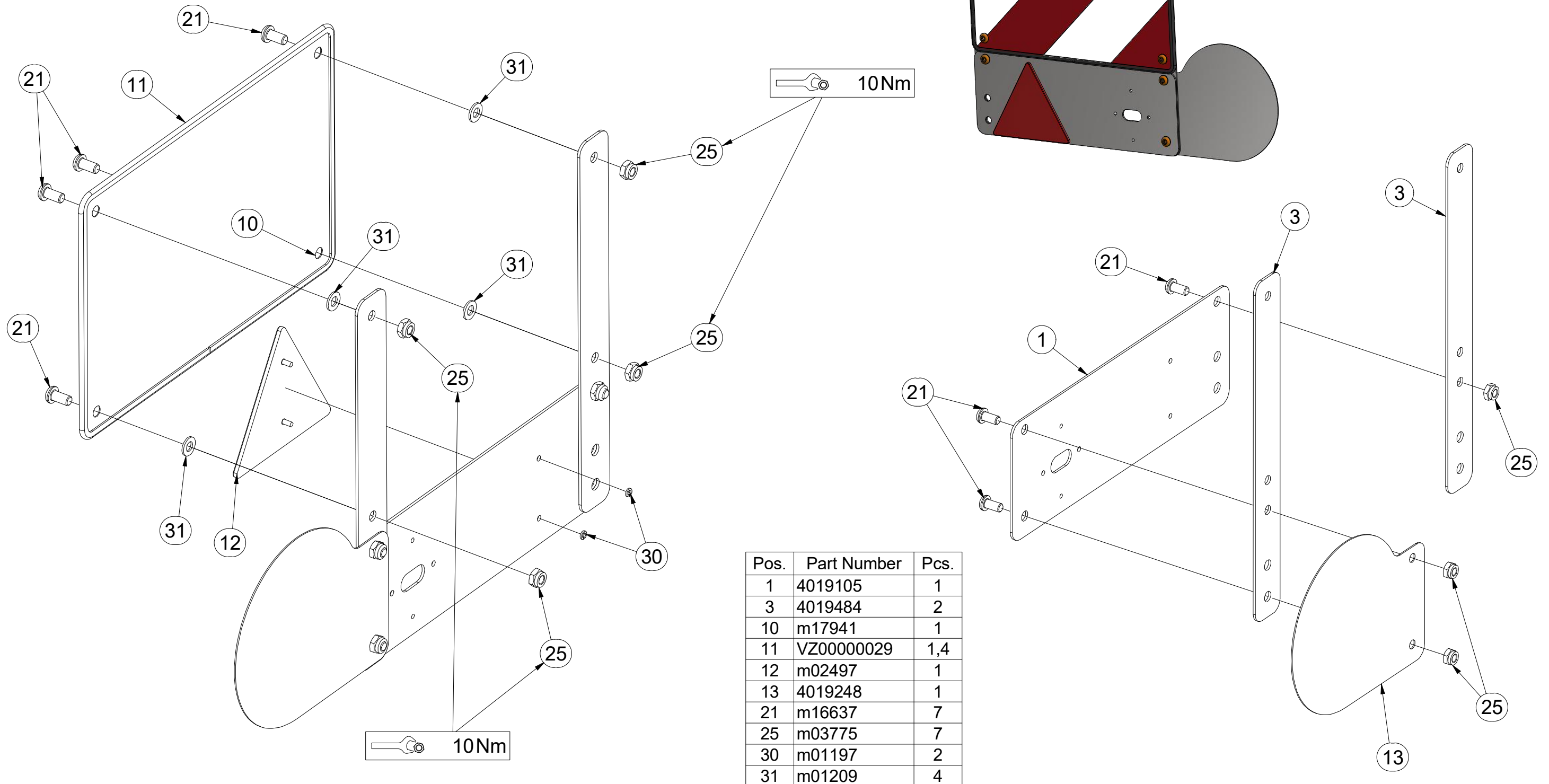

Pos.	Part Number	Pcs.
1	4019105	1
3	4019484	2
10	m17941	1
11	VZ00000029	1,4
12	m02497	1
13	4019248	1
21	m16637	7
25	m03775	7
30	m01197	2
31	m01209	4

ⒸZ TERČ ZADNÍ PRAVÝ

Ⓓ SCHILD, HINTERES, RECHTES

Ⓕ CIBLE ARRIÈRE DROITE

ⒸB RIGHT REAR DISC

ⒸU ЩИТОК ЗАДНИЙ ПРАВЫЙ

ⒸL TARCZA TYLNA PRAWA



3009543

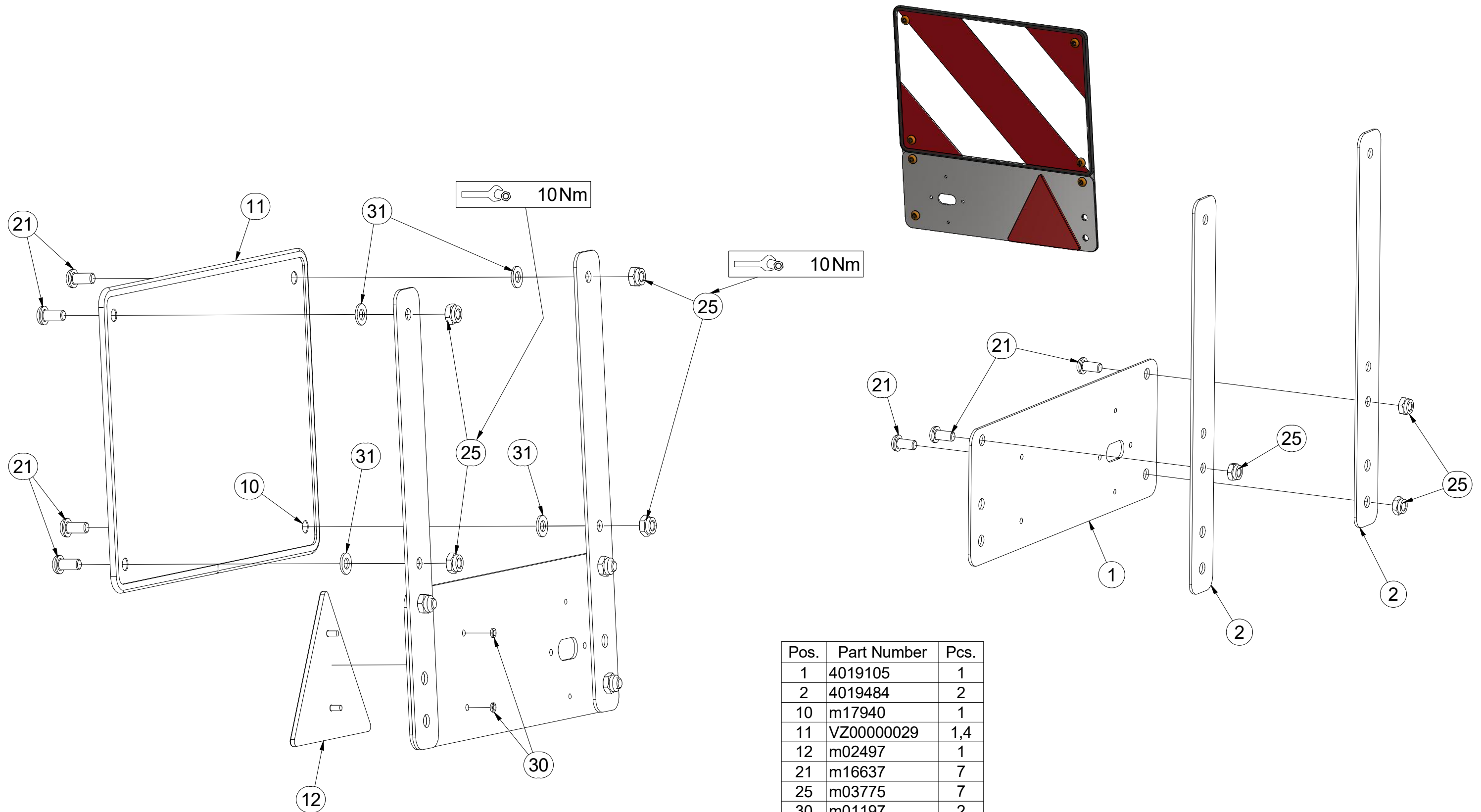

Pos.	Part Number	Pcs.
1	4019105	1
2	4019484	2
10	m17940	1
11	VZ00000029	1,4
12	m02497	1
21	m16637	7
25	m03775	7
30	m01197	2
31	m01209	4

Ⓒ VÝSTRAŽNÝ TROJÚHELNÍK

Ⓓ WARNDREIECK

Ⓕ TRIANGLE D'AVERTISSEMENT

Ⓖ EMERGENCY TRIANGLE

Ⓡ ЗНАК АВАРИЙНОЙ ОСТАНОВКИ

Ⓟ TRÓJKAT OSTRZEGAWCZY



4007398

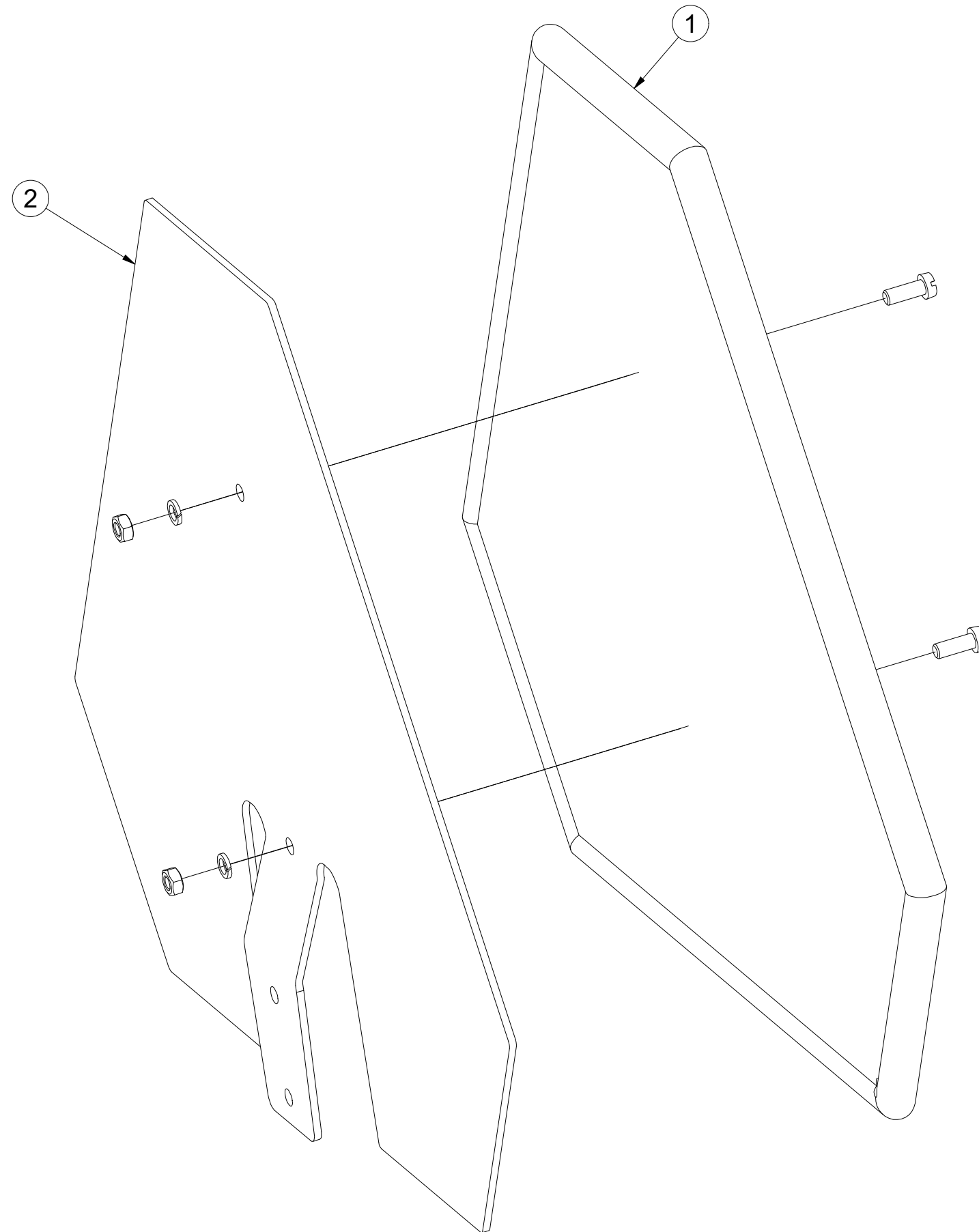
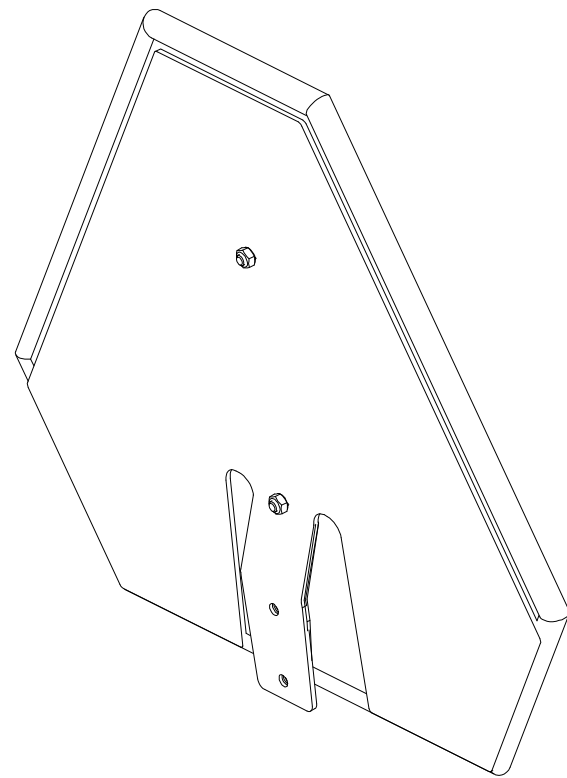

Pos.	Part Number	Pcs.
1	m05371	1
2	3003785	1

ⒸZ HYDRAULICKÝ ROZVOD - ZAHLUBOVÁNÍ

Ⓓ HYDRAULISCHE VERTEILUNG - EINSENKUNG

Ⓕ CONDUIT HYDRAULIQUE - L'ENFONCEMENT

ⒸB HYDRAULIC DISTRIBUTION - RECESSING

ⒸU ГИДРАВЛИЧЕСКОЕ РАСПРЕДЕЛЕНИЕ - ЗАГЛУБЛЕНИЕ

ⒸL HYDRAULICZNY PRZEWÓD - ZAGŁĘBIENIA

Farmet

VZ00010550

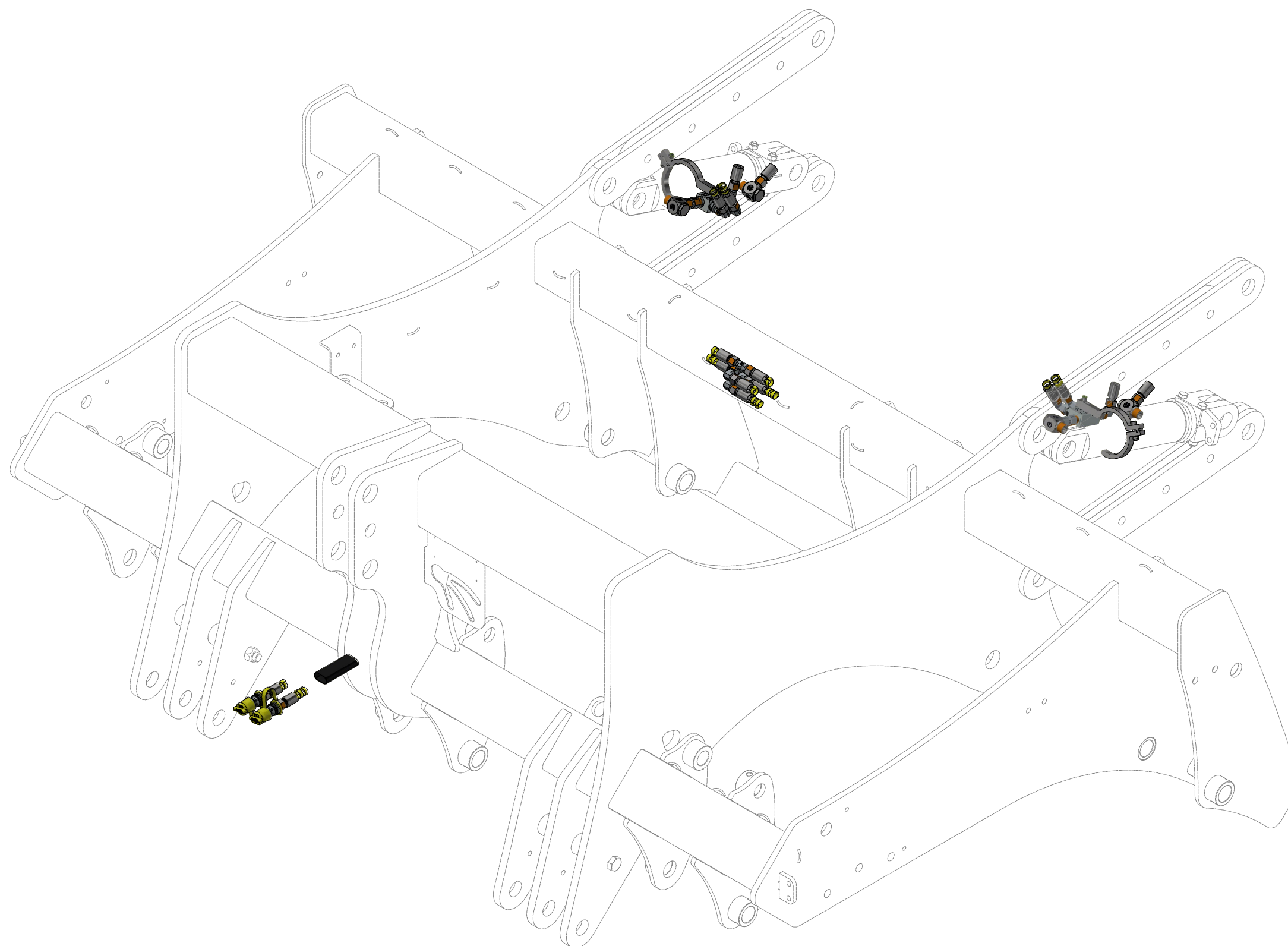

ⒸZ HYDRAULICKÝ ROZVOD - ZAHLUBOVÁNÍ

Ⓓ HYDRAULISCHE VERTEILUNG - EINSENKUNG

Ⓕ CONDUIT HYDRAULIQUE - L'ENFONCEMENT

ⒸB HYDRAULIC DISTRIBUTION - RECESSING

ⒸU ГИДРАВЛИЧЕСКОЕ РАСПРЕДЕЛЕНИЕ - ЗАГЛУБЛЕНИЕ

ⒸL HYDRAULICZNY PRZEWÓD - ZAGŁĘBIENIA



VZ00010550

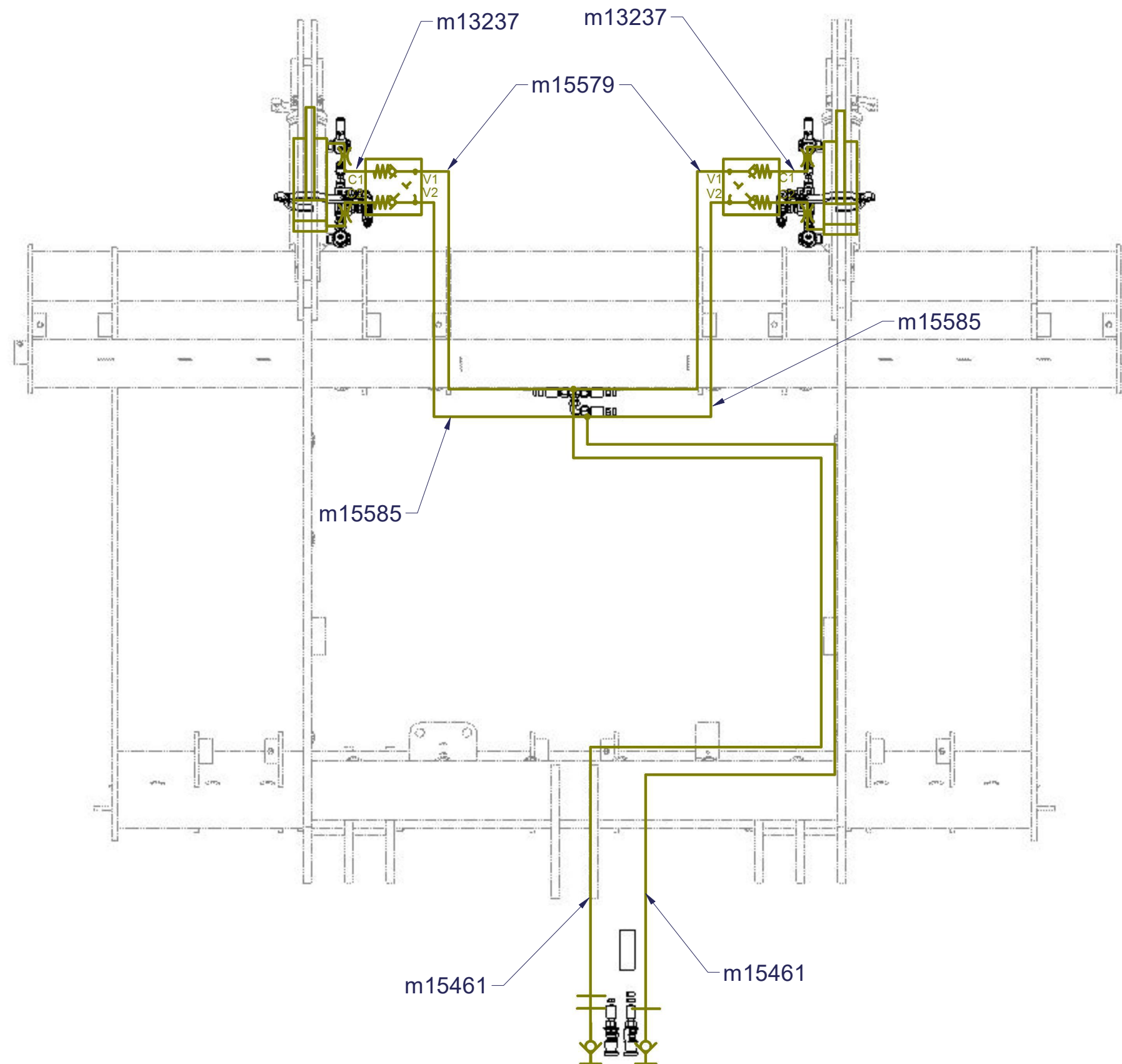

Pos.	Part Number	Pcs.
40	m13237	2
41	m15585	2
42	m15579	2
43	m15461	2

ⒸZ HYDRAULICKÝ ROZVOD - ZAHLUBOVÁNÍ

Ⓓ HYDRAULISCHE VERTEILUNG - EINSENKUNG

Ⓕ CONDUIT HYDRAULIQUE - L'ENFONCEMENT

ⒸGB HYDRAULIC DISTRIBUTION - RECESSING

ⒸRU ГИДРАВЛИЧЕСКОЕ РАСПРЕДЕЛЕНИЕ - ЗАГЛУБЛЕНИЕ

ⒸPL HYDRAULICZNY PRZEWÓD - ZAGŁĘBIENIA



VZ00010550

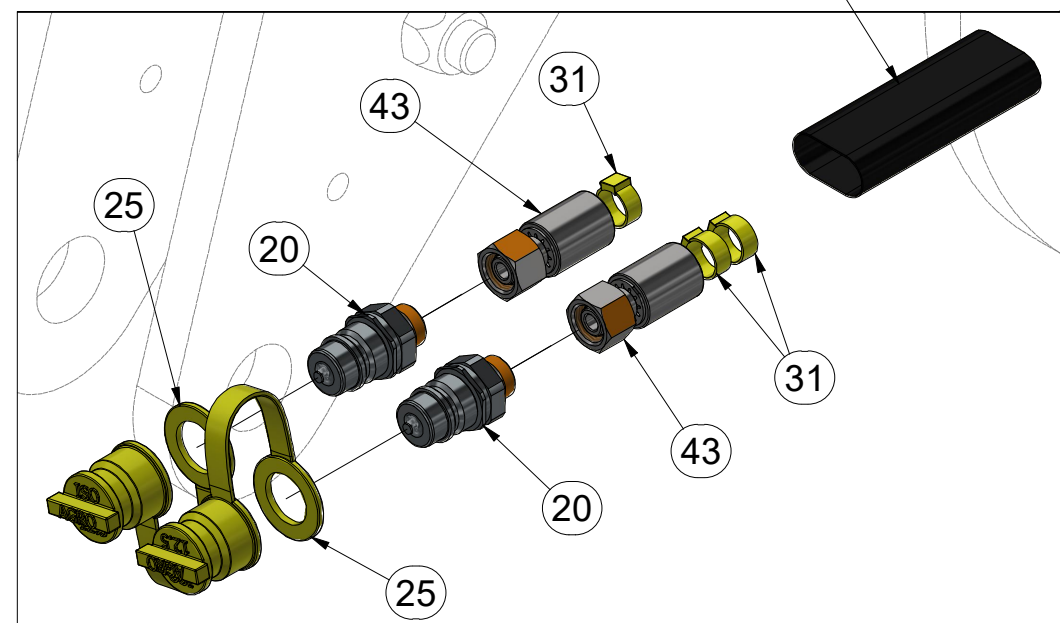
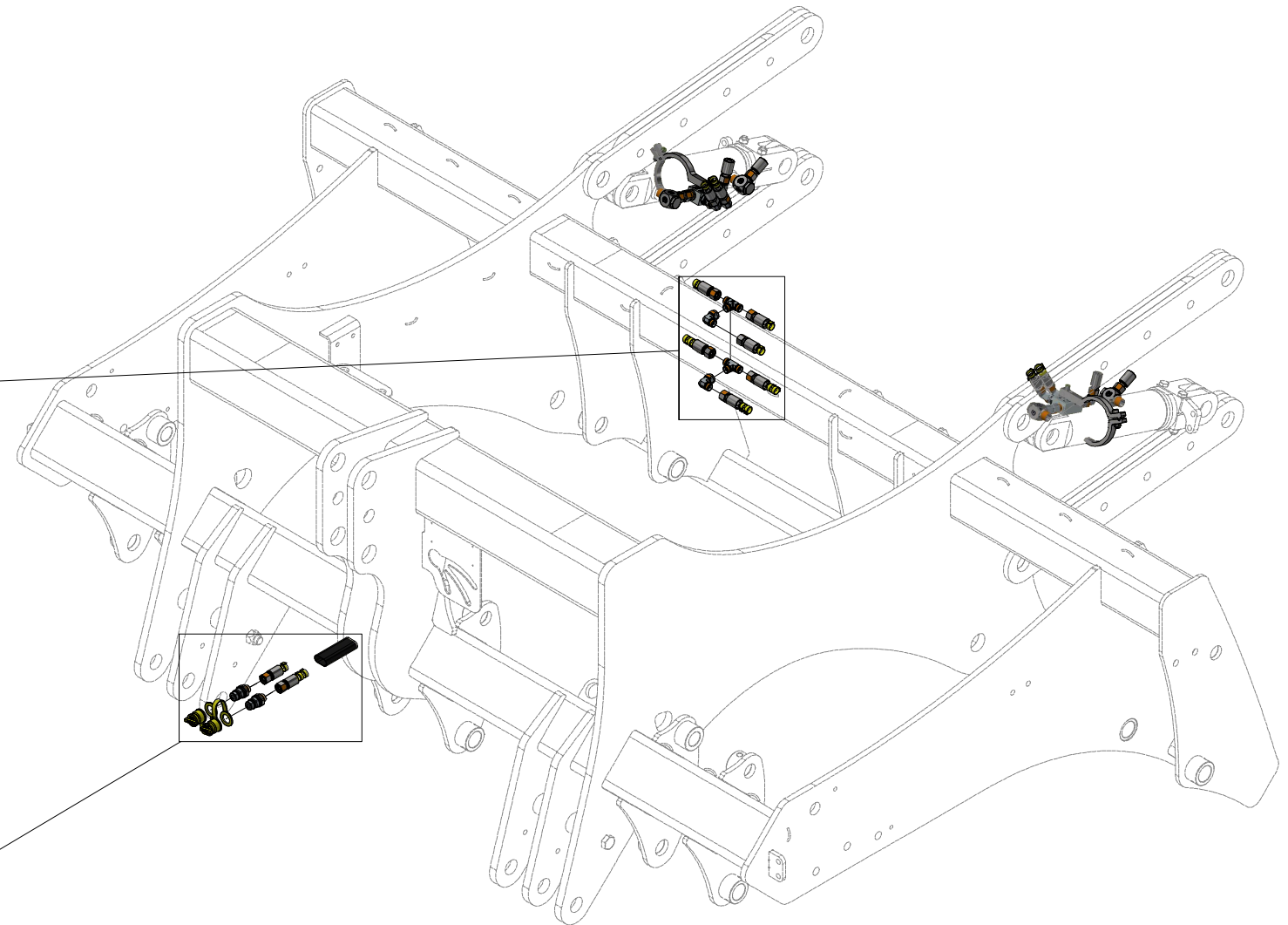
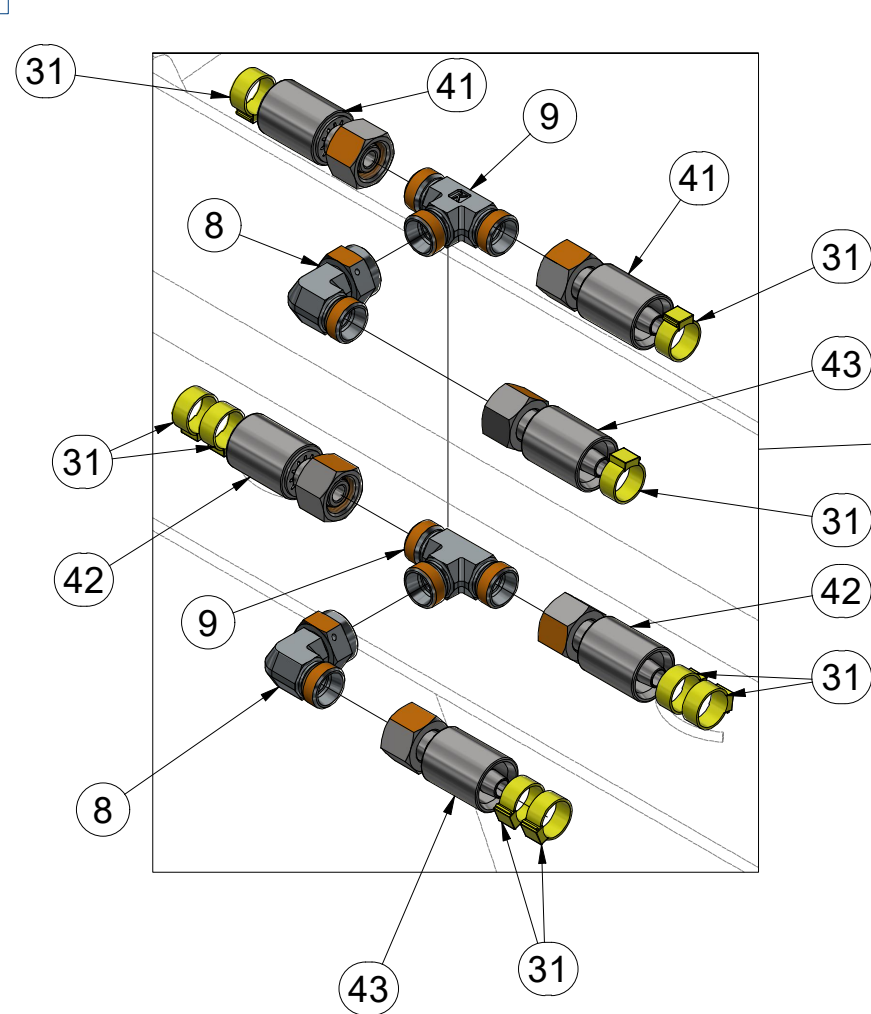

Pos.	Part Number	Pcs.	Pos.	Part Number	Pcs.
8	m07654	8	31	m11289	18
9	m02632	2	41	m15585	2
20	m04481	2	42	m15579	2
25	m04023	2	43	m15461	2
30	m11183	1			

ⒸZ HYDRAULICKÝ ROZVOD - ZAHLUBOVÁNÍ

Ⓓ HYDRAULISCHE VERTEILUNG - EINSENKUNG

Ⓕ CONDUIT HYDRAULIQUE - L'ENFONCEMENT

ⒸB HYDRAULIC DISTRIBUTION - RECESSING

ⒸU ГИДРАВЛИЧЕСКОЕ РАСПРЕДЕЛЕНИЕ - ЗАГЛУБЛЕНИЕ

ⒸL HYDRAULICZNY PRZEWÓD - ZAGŁĘBIENIA



VZ00010550

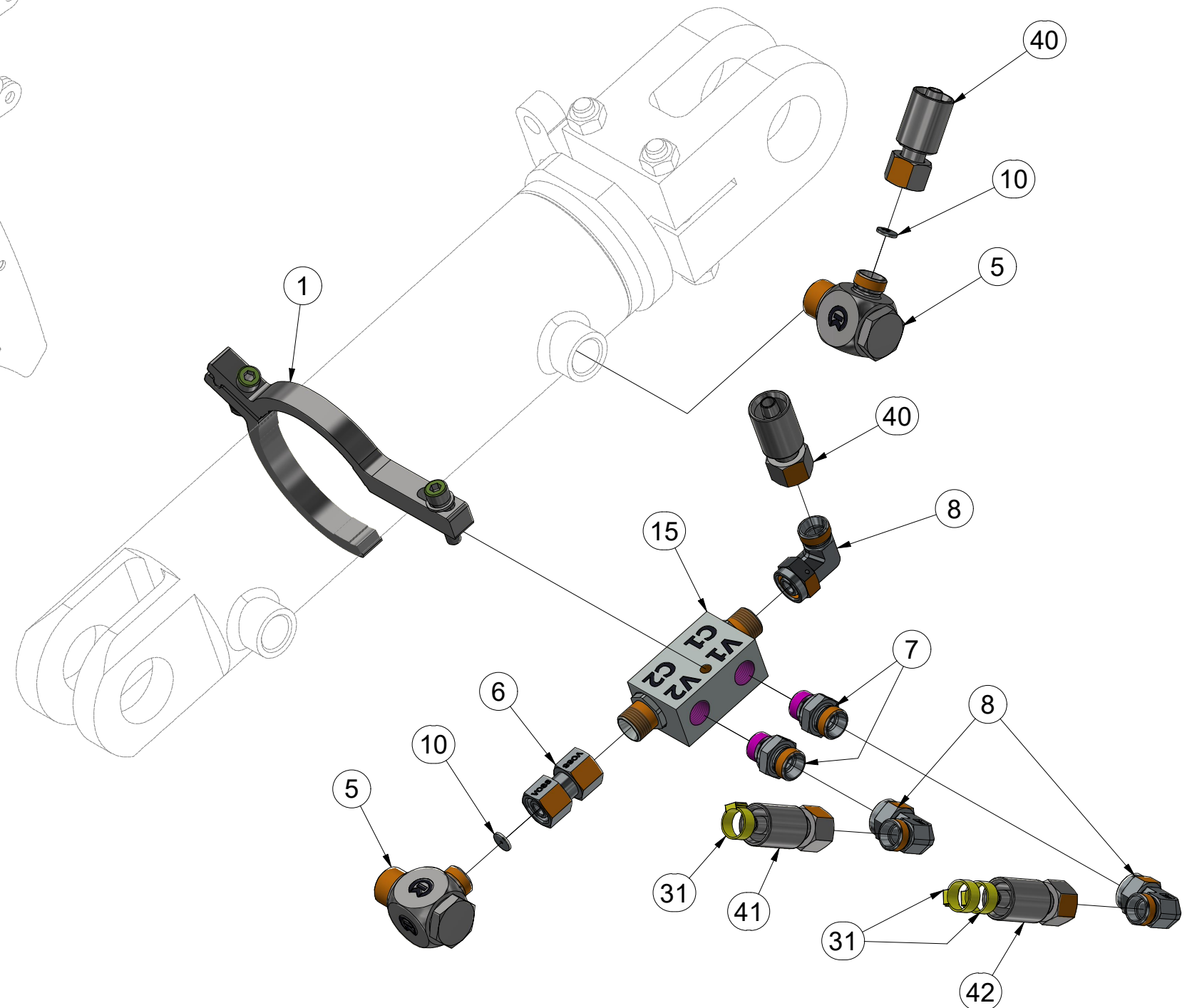
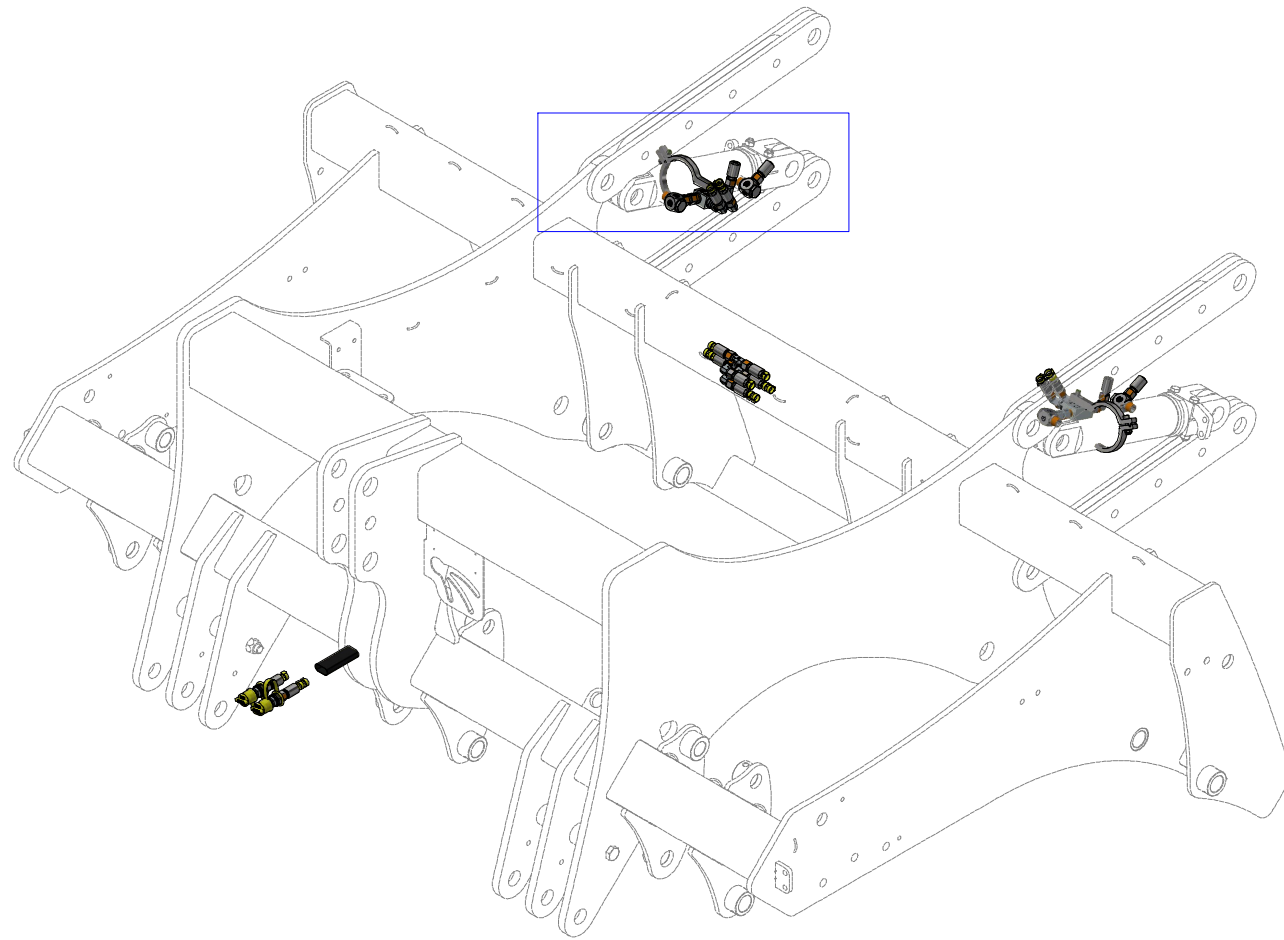

Pos.	Part Number	Pcs.	Pos.	Part Number	Pcs.
1	VZ00010412	2	15	m08083	2
5	m20912	4	31	m11289	18
6	m22306	2	40	m13237	2
7	m06320	4	41	m15585	2
8	m07654	8	42	m15579	2
10	m10762	4			

ⒸZ HYDRAULICKÝ ROZVOD - ZAHLUBOVÁNÍ

Ⓓ HYDRAULISCHE VERTEILUNG - EINSENKUNG

Ⓕ CONDUIT HYDRAULIQUE - L'ENFONCEMENT

ⒸB HYDRAULIC DISTRIBUTION - RECESSING

ⒸU ГИДРАВЛИЧЕСКОЕ РАСПРЕДЕЛЕНИЕ - ЗАГЛУБЛЕНИЕ

ⒸL HYDRAULICZNY PRZEWÓD - ZAGŁĘBIENIA



VZ00010550

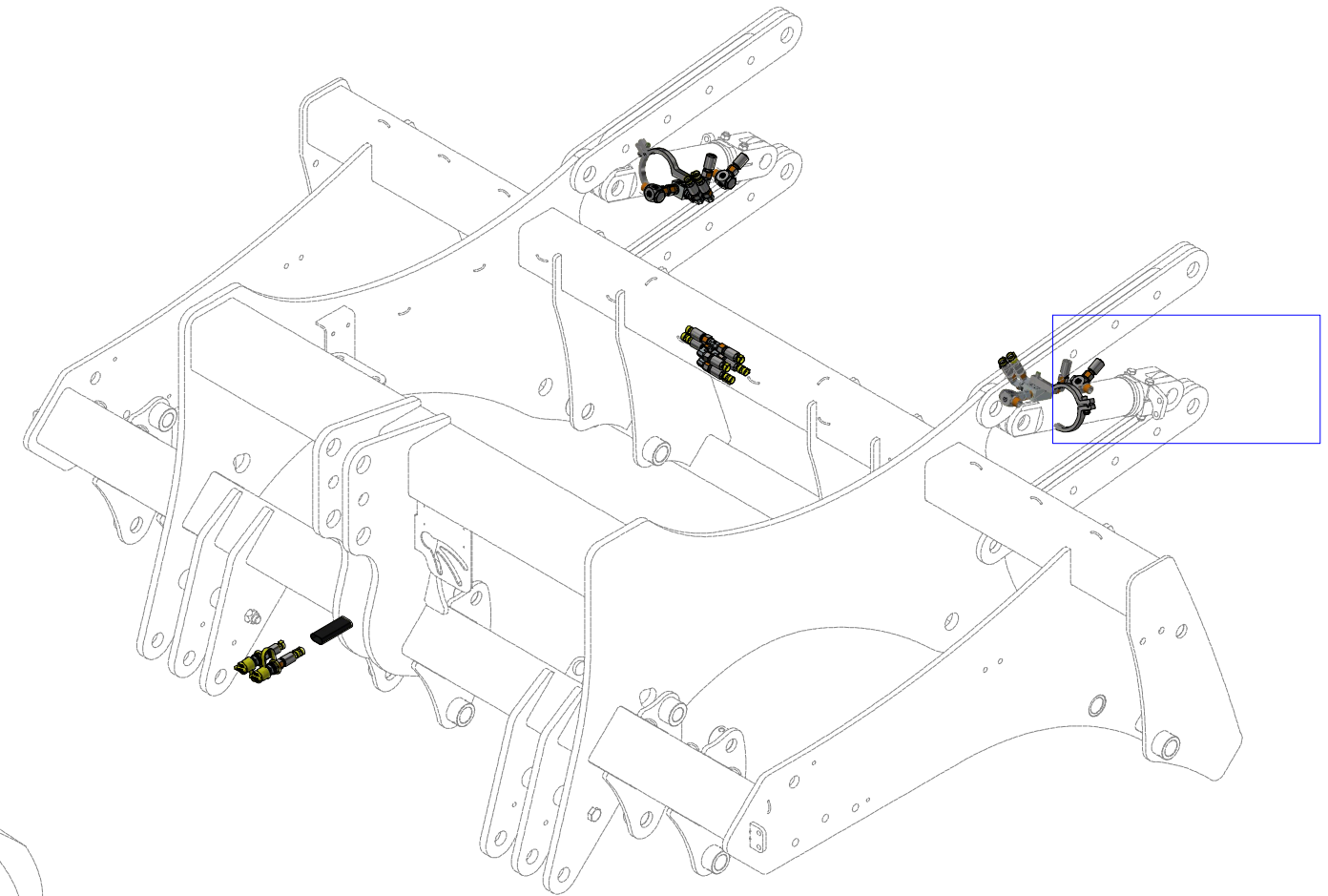
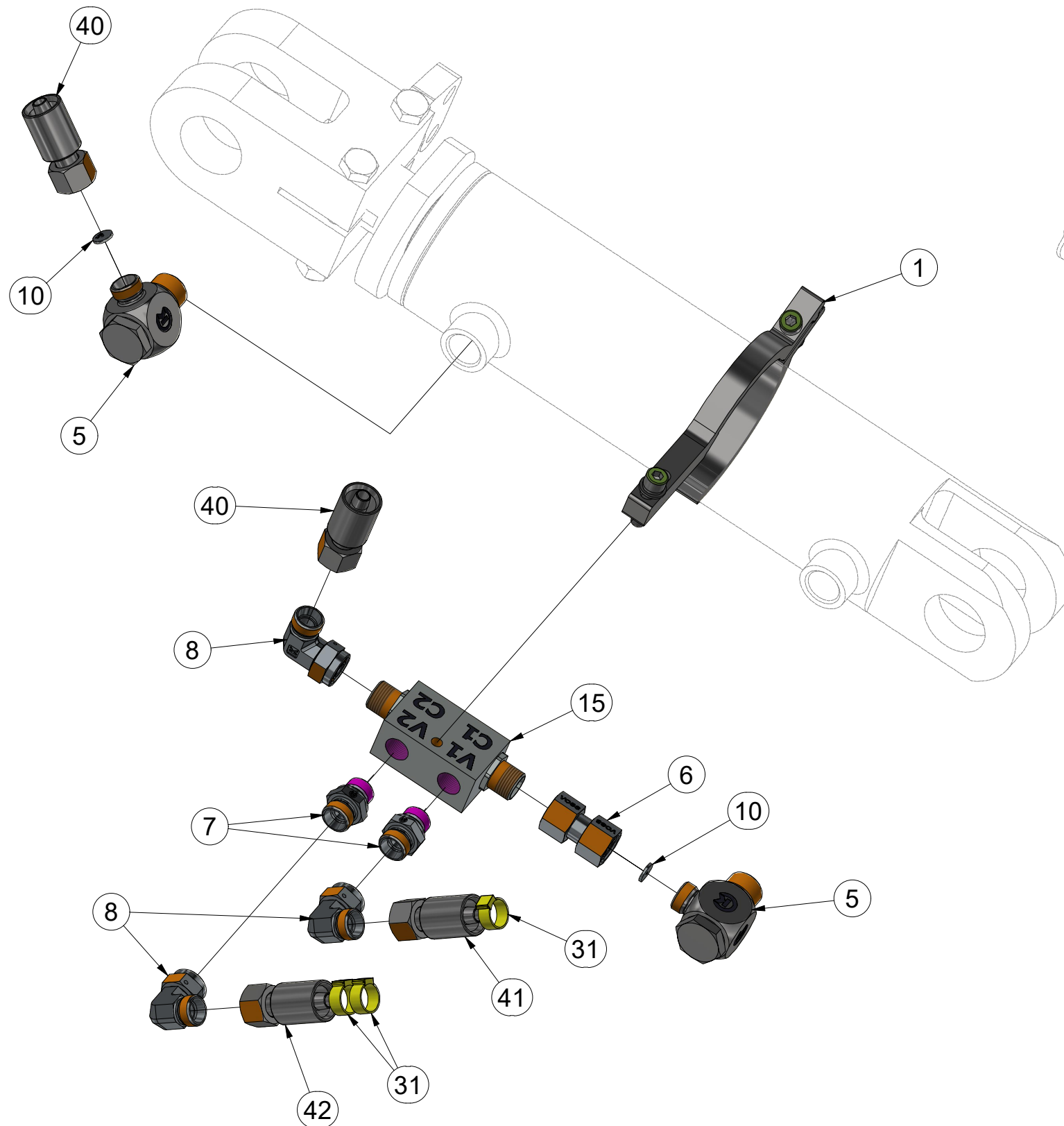

Pos.	Part Number	Pcs.	Pos.	Part Number	Pcs.
1	VZ00010412	2	15	m08083	2
5	m20912	4	31	m11289	18
6	m22306	2	40	m13237	2
7	m06320	4	41	m15585	2
8	m07654	8	42	m15579	2
10	m10762	4			

ⒸZ HYDRAULIKA STROJE
Ⓓ HYDRAULIK DER MASCHINE
Ⓕ F HYDRAULIQUE DE LA MACHINE

ⒸB MACHINE HYDRAULICS
ⒸR ГИДРАВЛИКА МАШИНЫ
ⒸL HYDRAULIKA MASZYN



VZ00010551

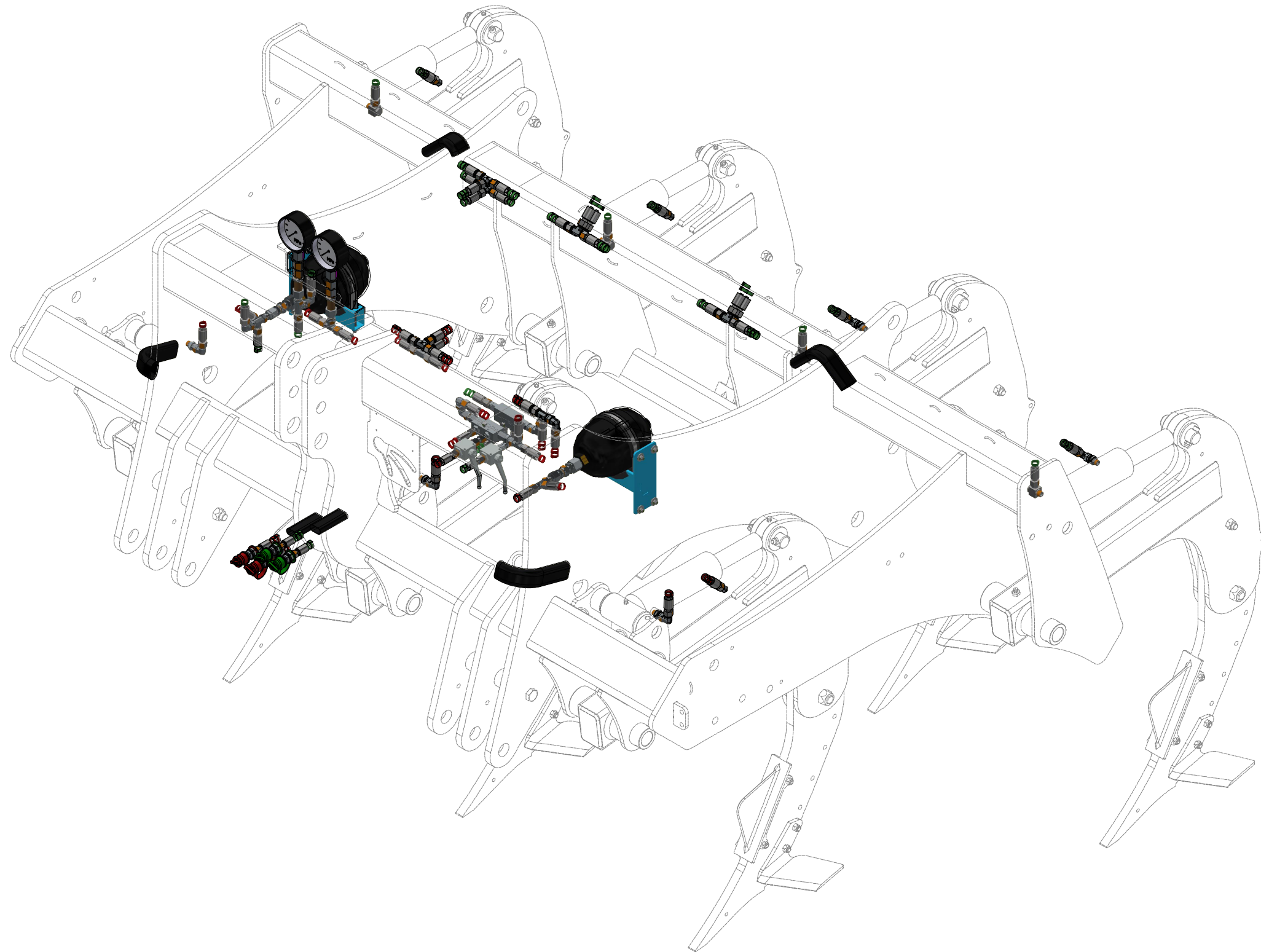

VZ00010551

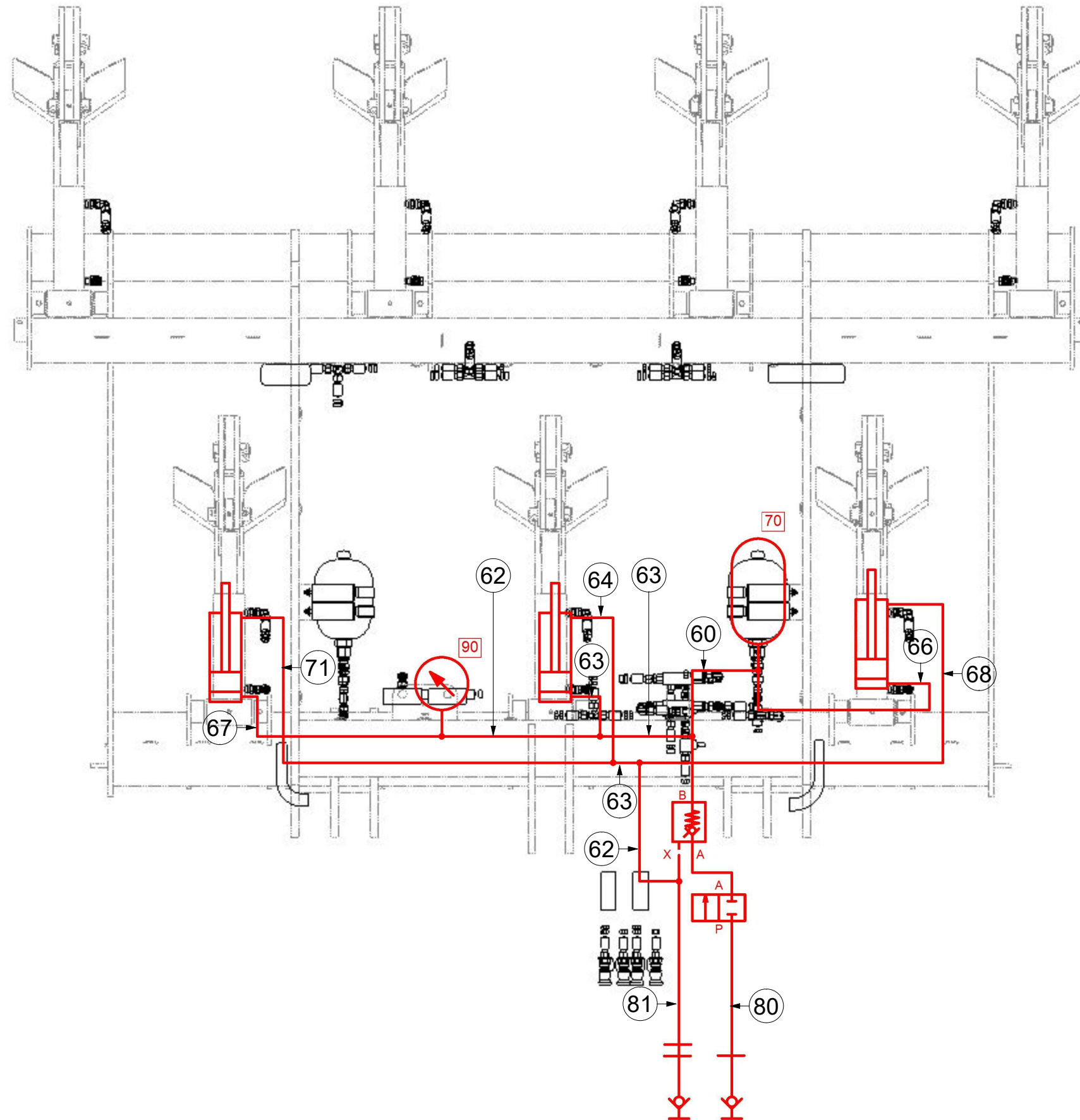

Pos.	Part Number	Pcs.
60	m10830	2
62	m03845	2
63	m03844	3
64	m15583	3
66	m15580	3
67	m15439	1
68	m15584	3
71	m15579	2
80	m07360	2
81	m05762	2

VZ00010551

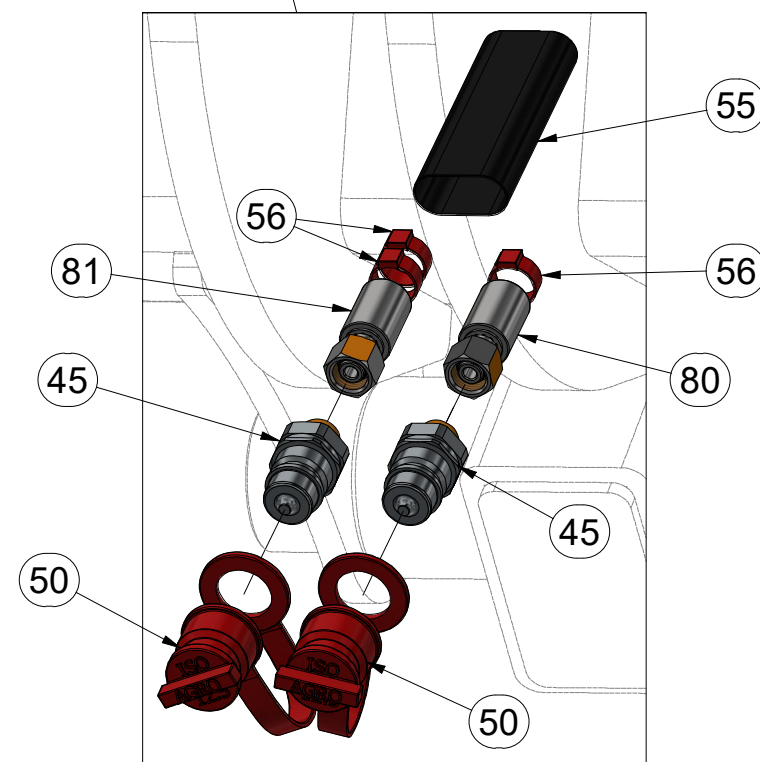
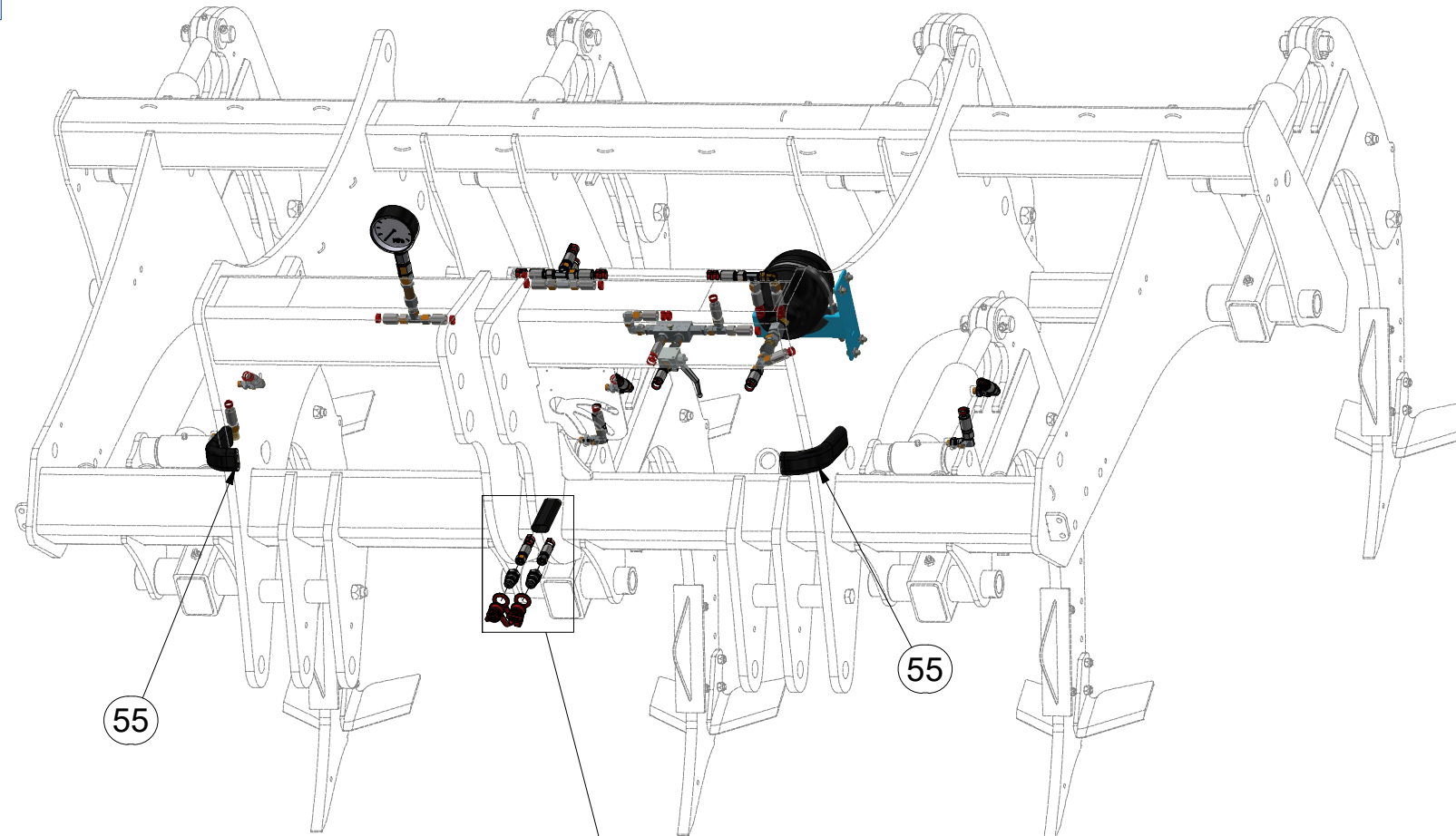

Pos.	Part Number	Pcs.
45	m03849	4
50	m04022	2
55	m11183	6
56	m11294	38
80	m07360	2
81	m05762	2

ⒸZ HYDRAULIKA STROJE

Ⓓ HYDRAULIK DER MASCHINE

Ⓕ HYDRAULIQUE DE LA MACHINE

ⒼB MACHINE HYDRAULICS

Ⓔ RU ГИДРАВЛИКА МАШИНЫ

Ⓕ PL HYDRAULIKA MASZYNY



VZ00010551

Pos.	Part Number	Pcs.
7	m07654	17
19	m10097	10
56	m11294	38
63	m03844	3
64	m15583	3
66	m15580	3
67	m15439	1
68	m15584	3
71	m15579	2

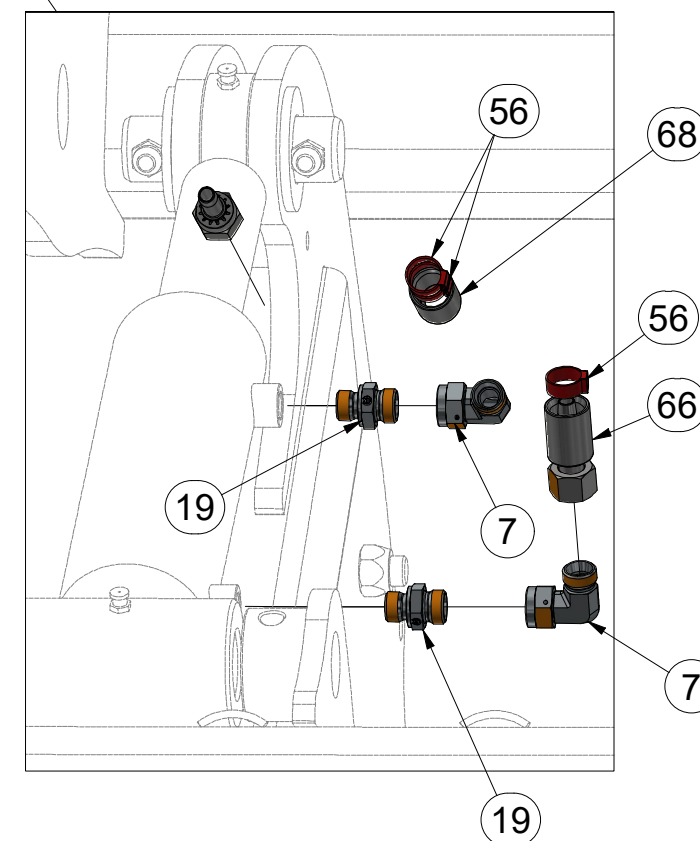
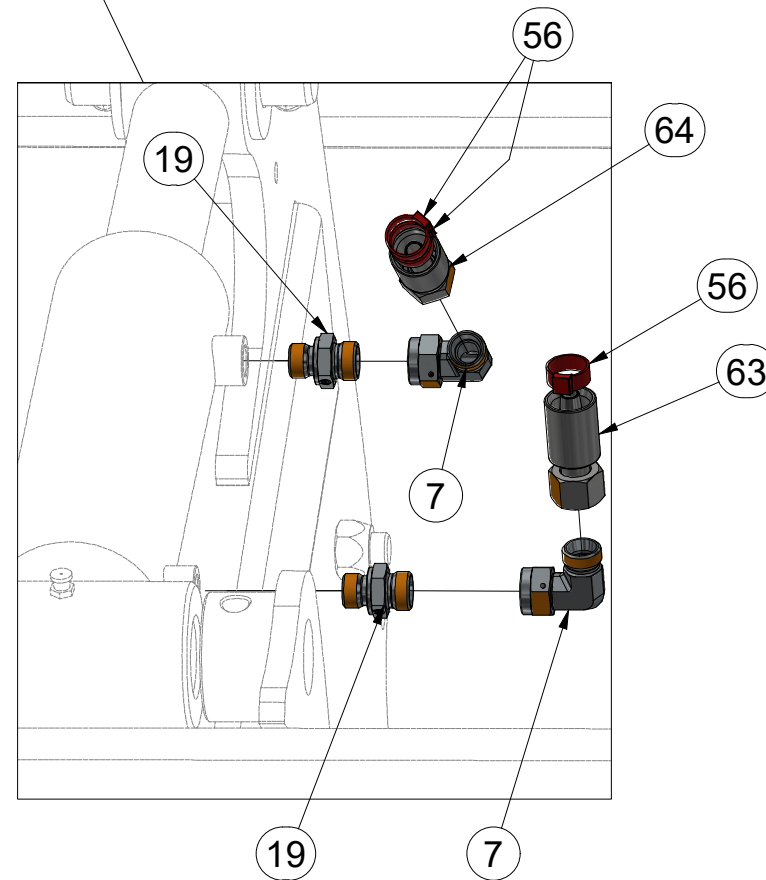
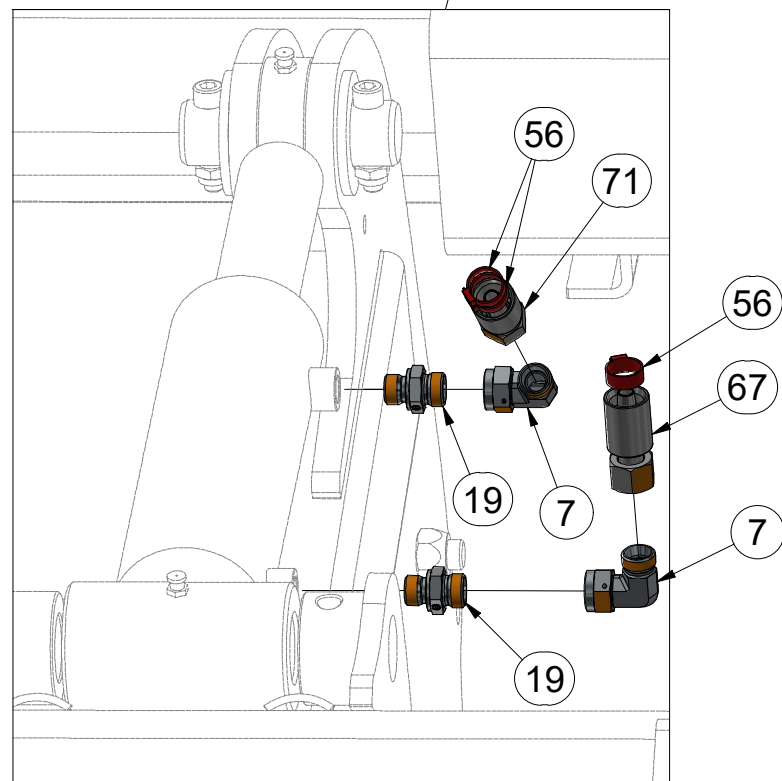
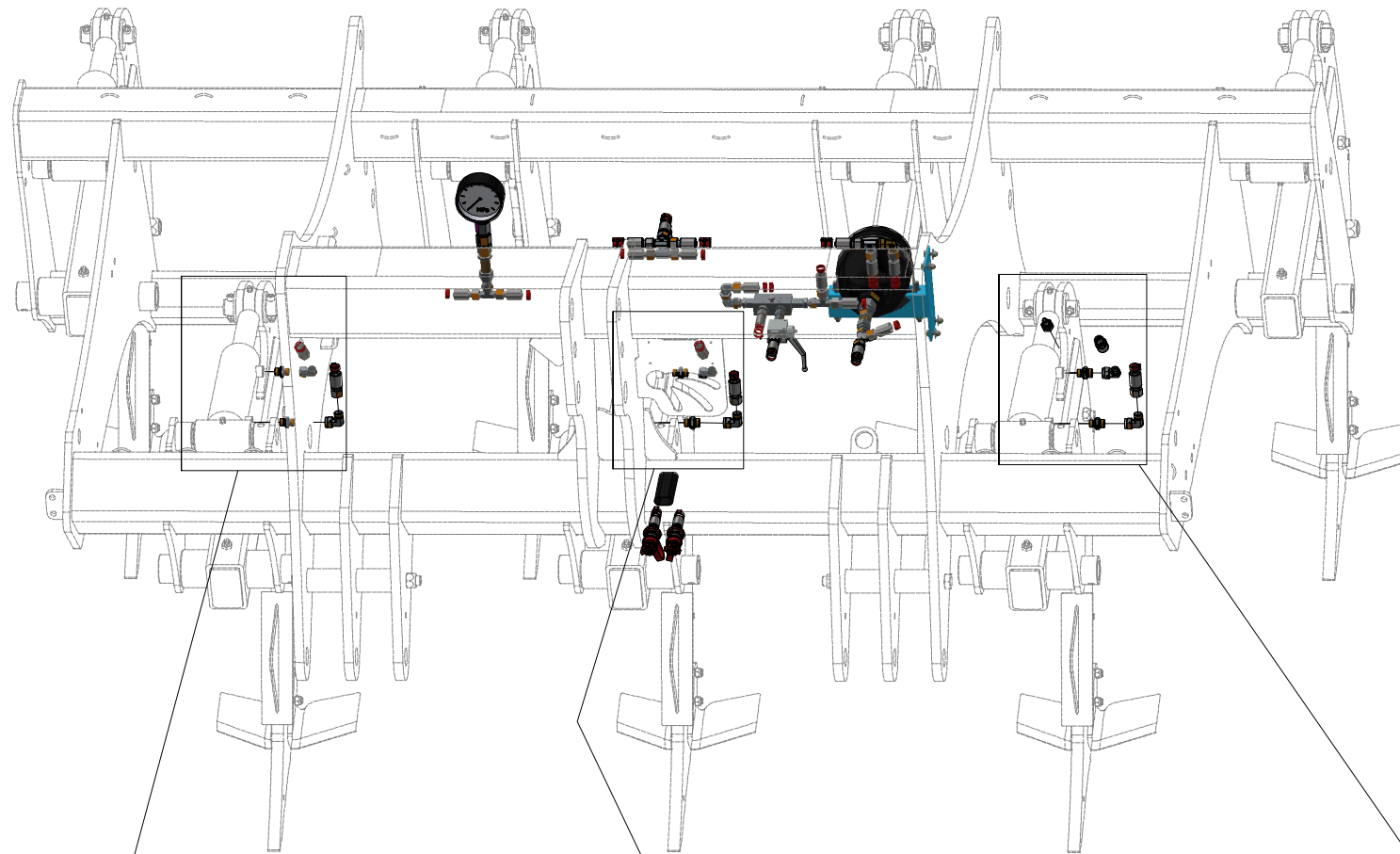

ⒸZ HYDRAULIKA STROJE

Ⓓ HYDRAULIK DER MASCHINE

Ⓕ HYDRAULIQUE DE LA MACHINE

ⒸB MACHINE HYDRAULICS

ⒸU ГИДРАВЛИКА МАШИНЫ

ⒸL HYDRAULIKA MASZYNY



VZ00010551

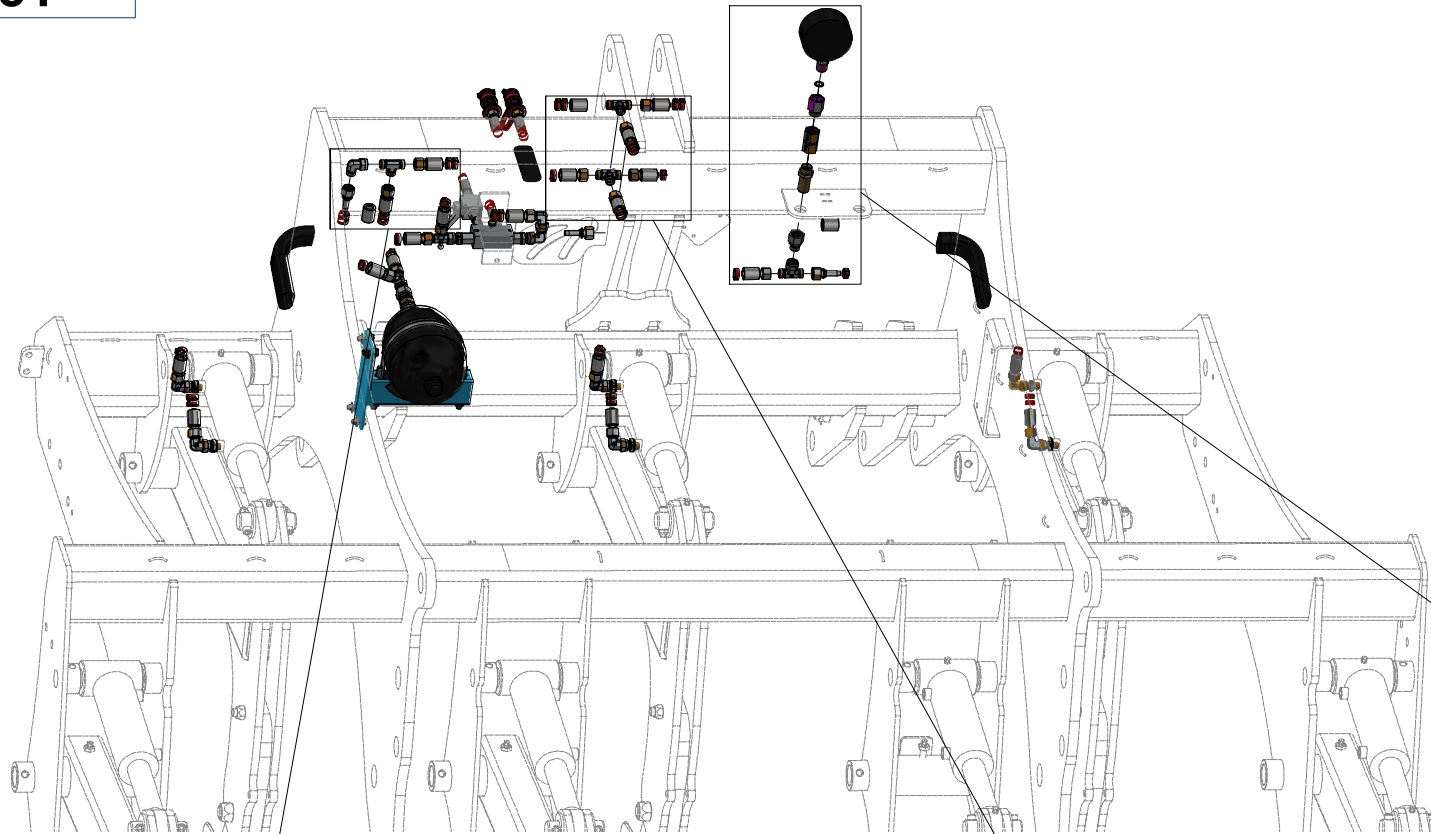

Pos.	Part Number	Pcs.	Pos.	Part Number	Pcs.
3	m07502	1	35	m05518	2
4	m02632	9	56	m11294	38
5	m09625	2	62	m03845	2
7	m07654	17	63	m03844	3
9	m09987	4	64	m15583	3
11	m11974	2	67	m15439	1
12	m22307	2	68	m15584	3
14	m04320	2	71	m15579	2

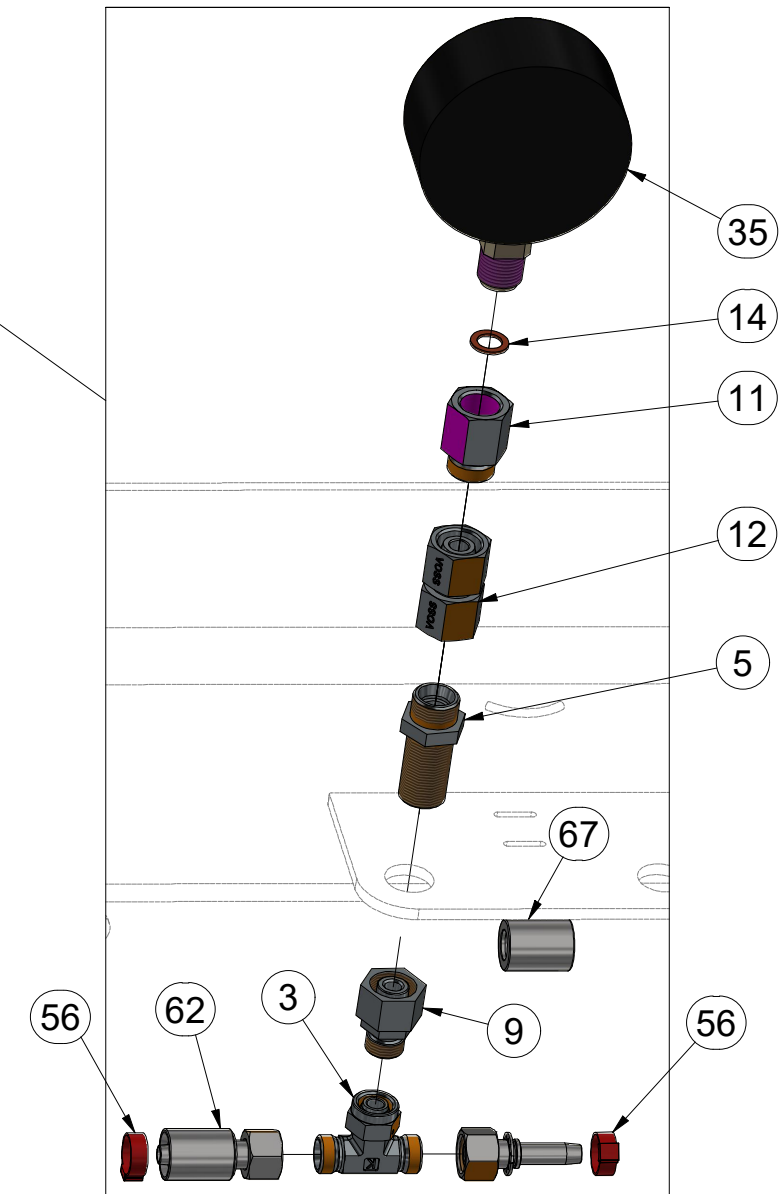
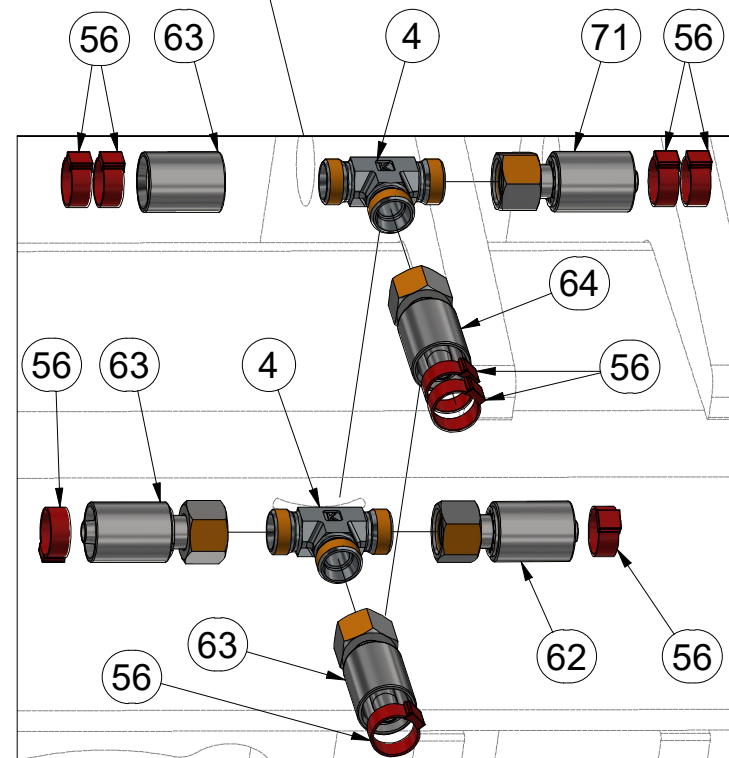
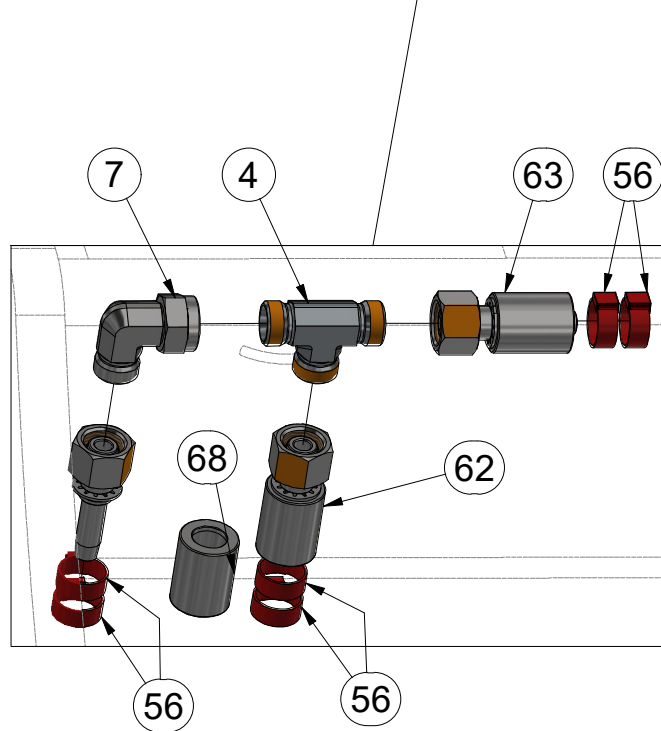

ⒸZ HYDRAULIKA STROJE

Ⓓ HYDRAULIK DER MASCHINE

Ⓕ HYDRAULIQUE DE LA MACHINE

ⒼB MACHINE HYDRAULICS

Ⓔ RU ГИДРАВЛИКА МАШИНЫ

Ⓔ PL HYDRAULIKA MASZYN



VZ00010551

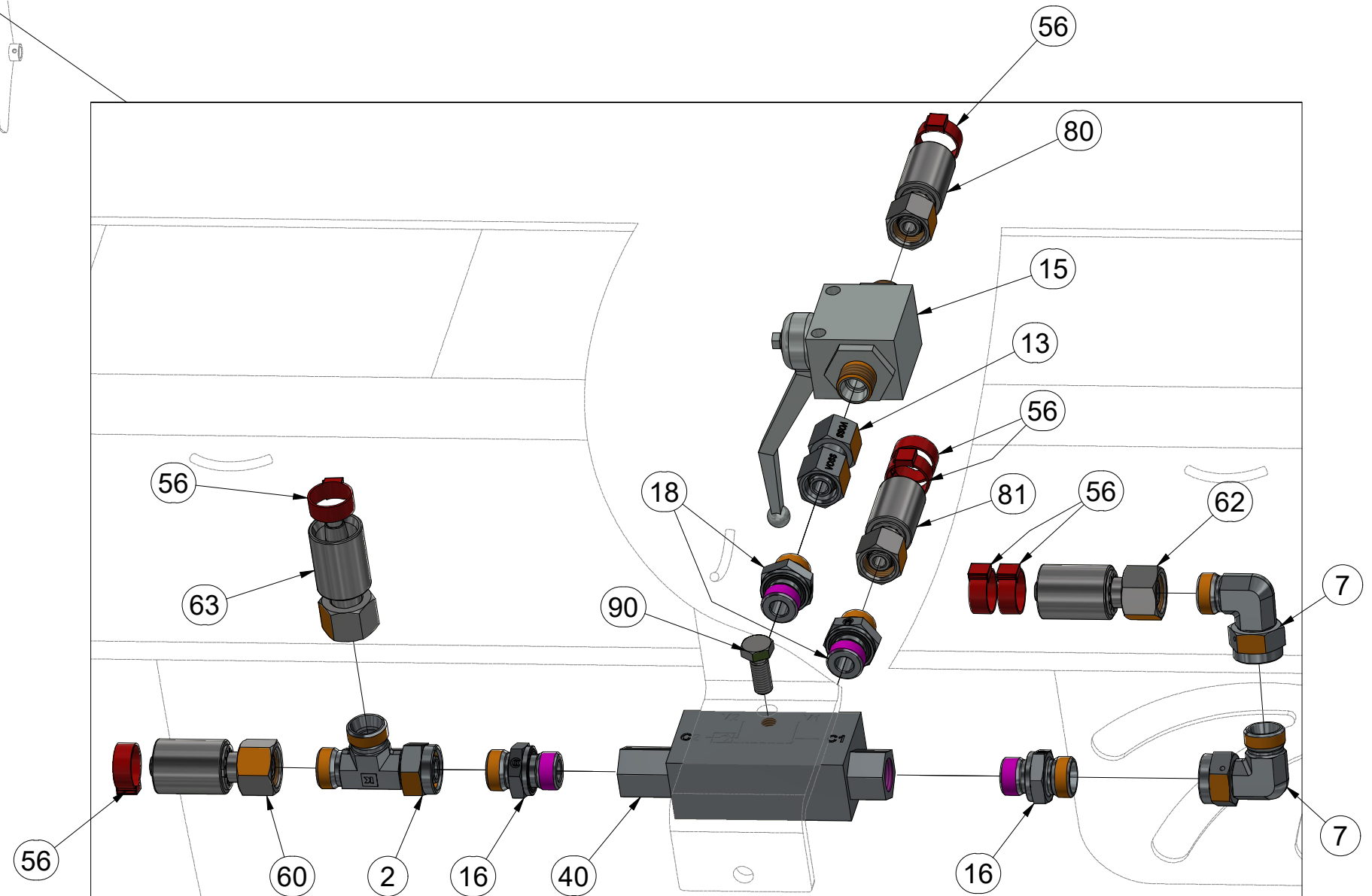
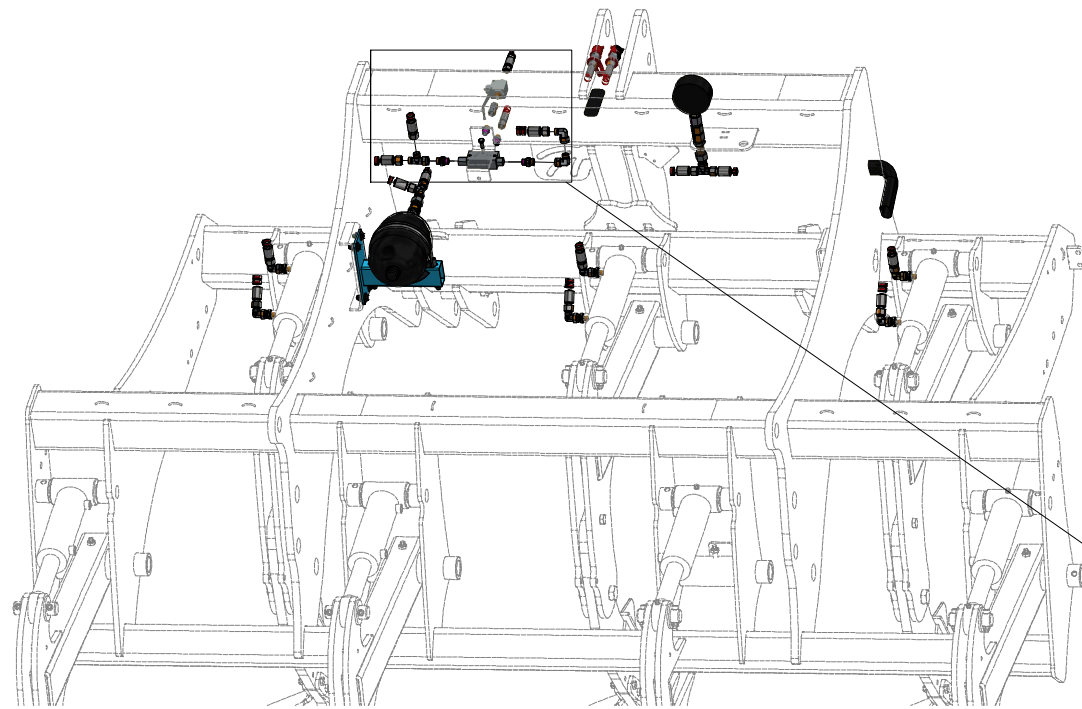

Pos.	Part Number	Pcs.	Pos.	Part Number	Pcs.
2	m08299	4	56	m11294	38
7	m07654	17	60	m10830	2
15	m04623	2	62	m03845	2
16	m06320	4	63	m03844	3
18	m06528	4	80	m07360	2
40	m11103	2	81	m05762	2
			90	m01089	2

ⒸZ HYDRAULIKA STROJE

Ⓓ HYDRAULIK DER MASCHINE

Ⓕ HYDRAULIQUE DE LA MACHINE

VZ00010551

ⒼB MACHINE HYDRAULICS

Ⓔ RU ГИДРАВЛИКА МАШИНЫ

Ⓗ PL HYDRAULIKA MASZYN

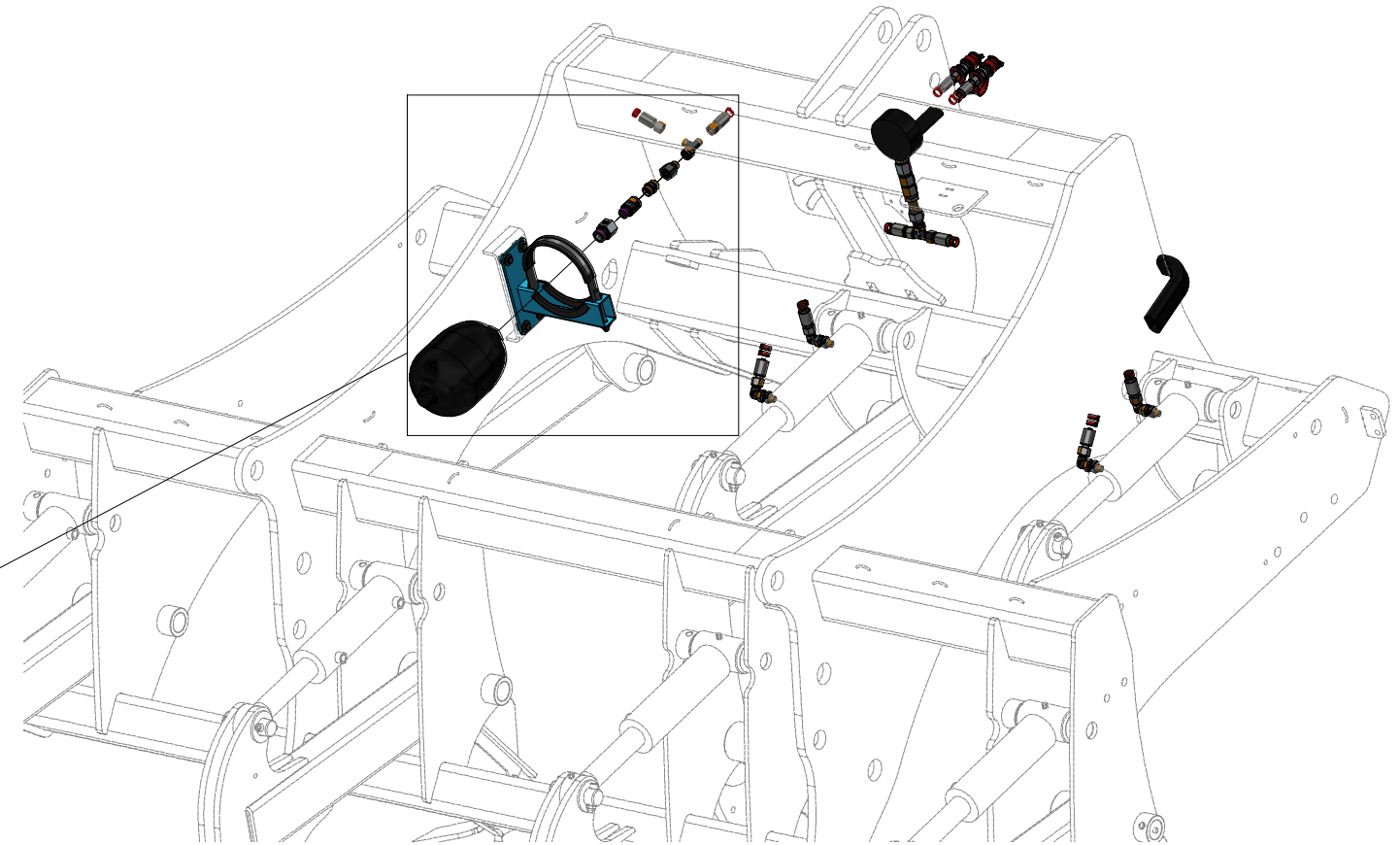
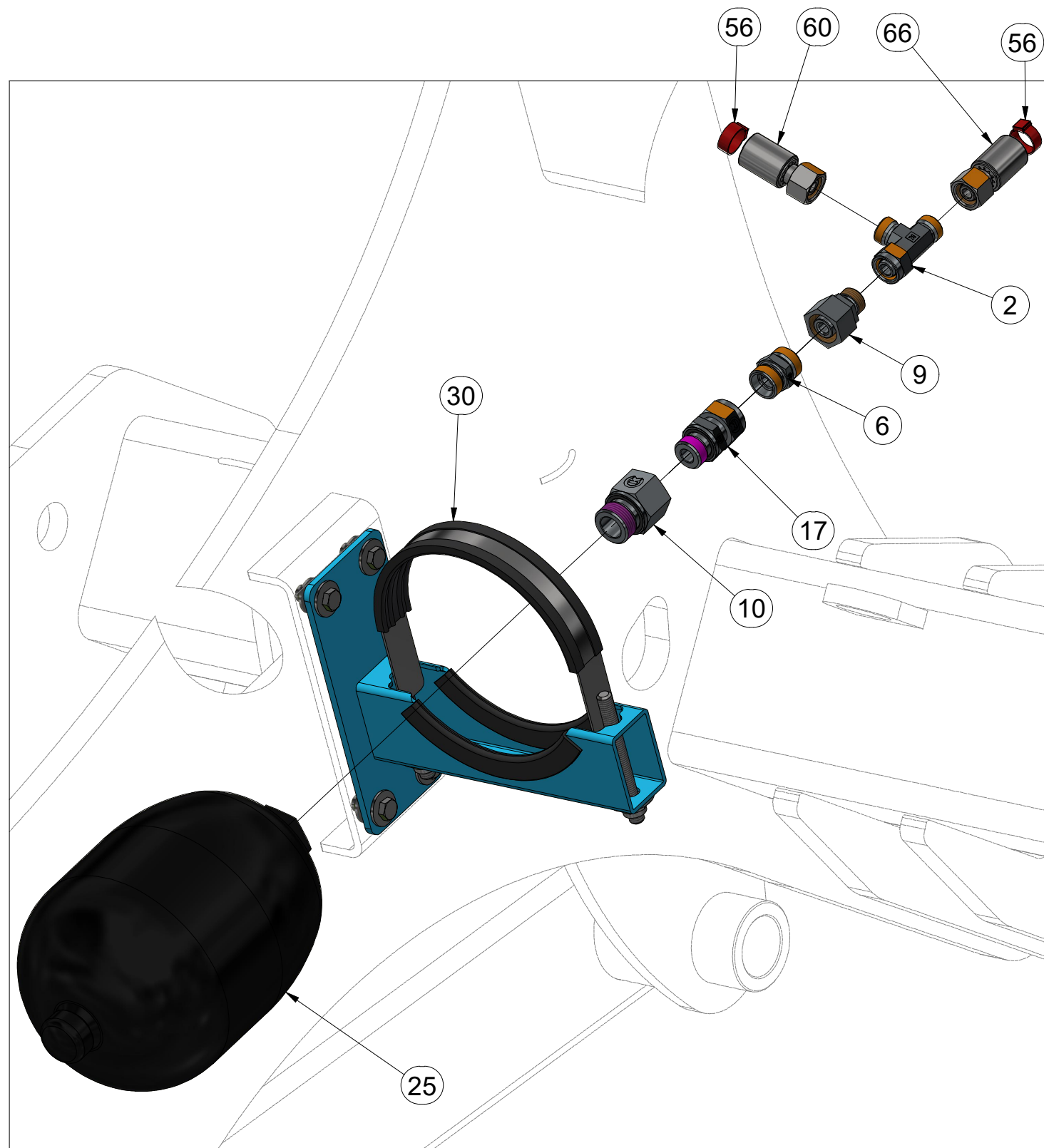

Pos.	Part Number	Pcs.
2	m08299	4
6	m04428	2
9	m09987	4
10	m13037	2
17	m07993	2
25	m21541	2
30	VZ00025939	2
56	m11294	38
60	m10830	2
66	m15580	3

ⒸZ HYDRAULIKA STROJE

Ⓓ HYDRAULIK DER MASCHINE

Ⓕ HYDRAULIQUE DE LA MACHINE

ⒼB MACHINE HYDRAULICS

Ⓔ RU ГИДРАВЛИКА МАШИНЫ

Ⓗ PL HYDRAULIKA MASZYNY



VZ00010551

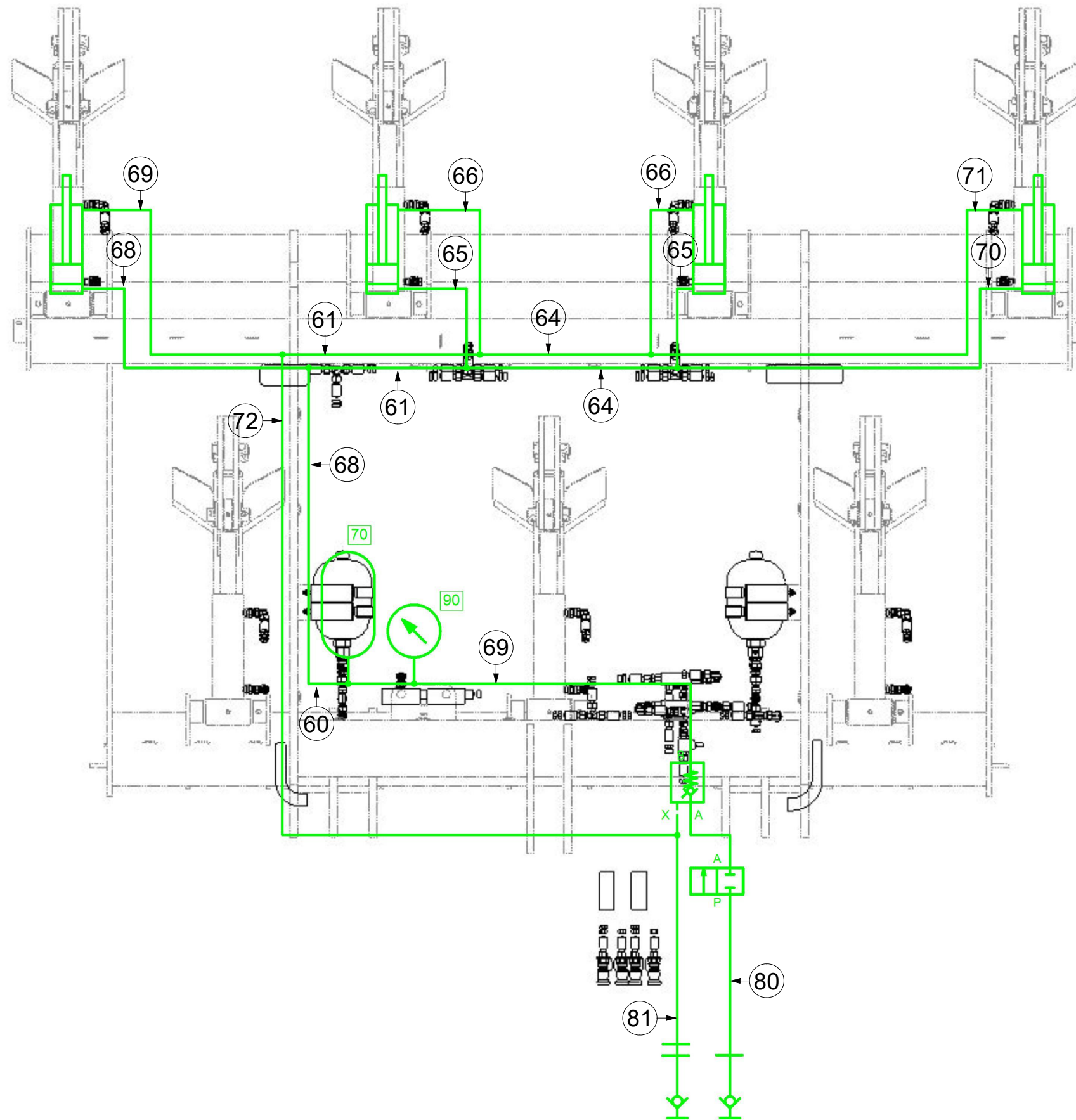

Pos.	Part Number	Pcs.
60	m10830	2
61	m13237	2
64	m15583	3
65	m07505	2
66	m15580	3
68	m15584	3
69	m04999	2
70	m15585	1
71	m15579	2
72	m02994	1
80	m07360	2
81	m05762	2

ⒸZ HYDRAULIKA STROJE

Ⓓ HYDRAULIK DER MASCHINE

Ⓕ HYDRAULIQUE DE LA MACHINE

ⒼB MACHINE HYDRAULICS

Ⓔ RU ГИДРАВЛИКА МАШИНЫ

Ⓗ PL HYDRAULIKA MASZYN



VZ00010551

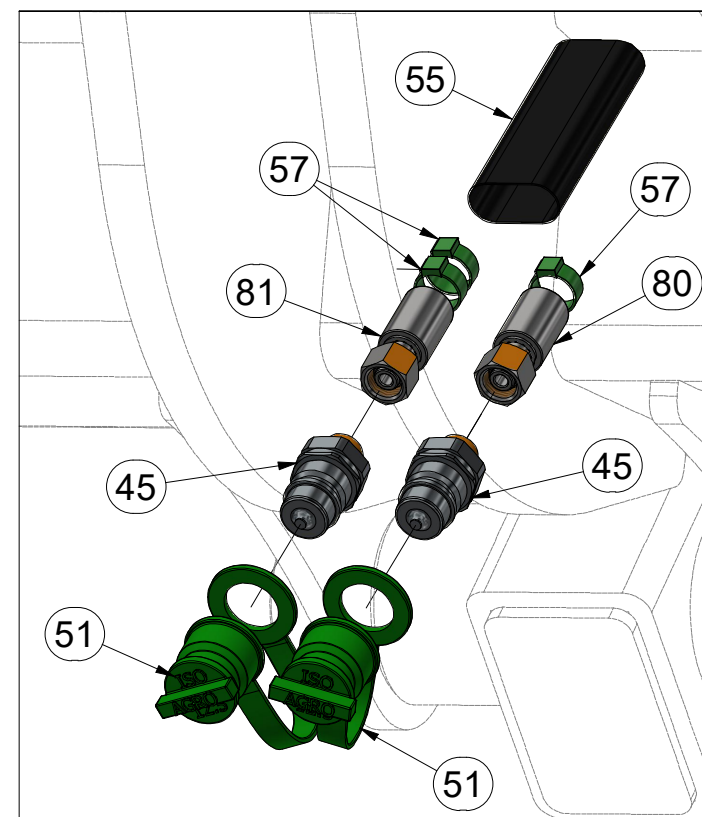
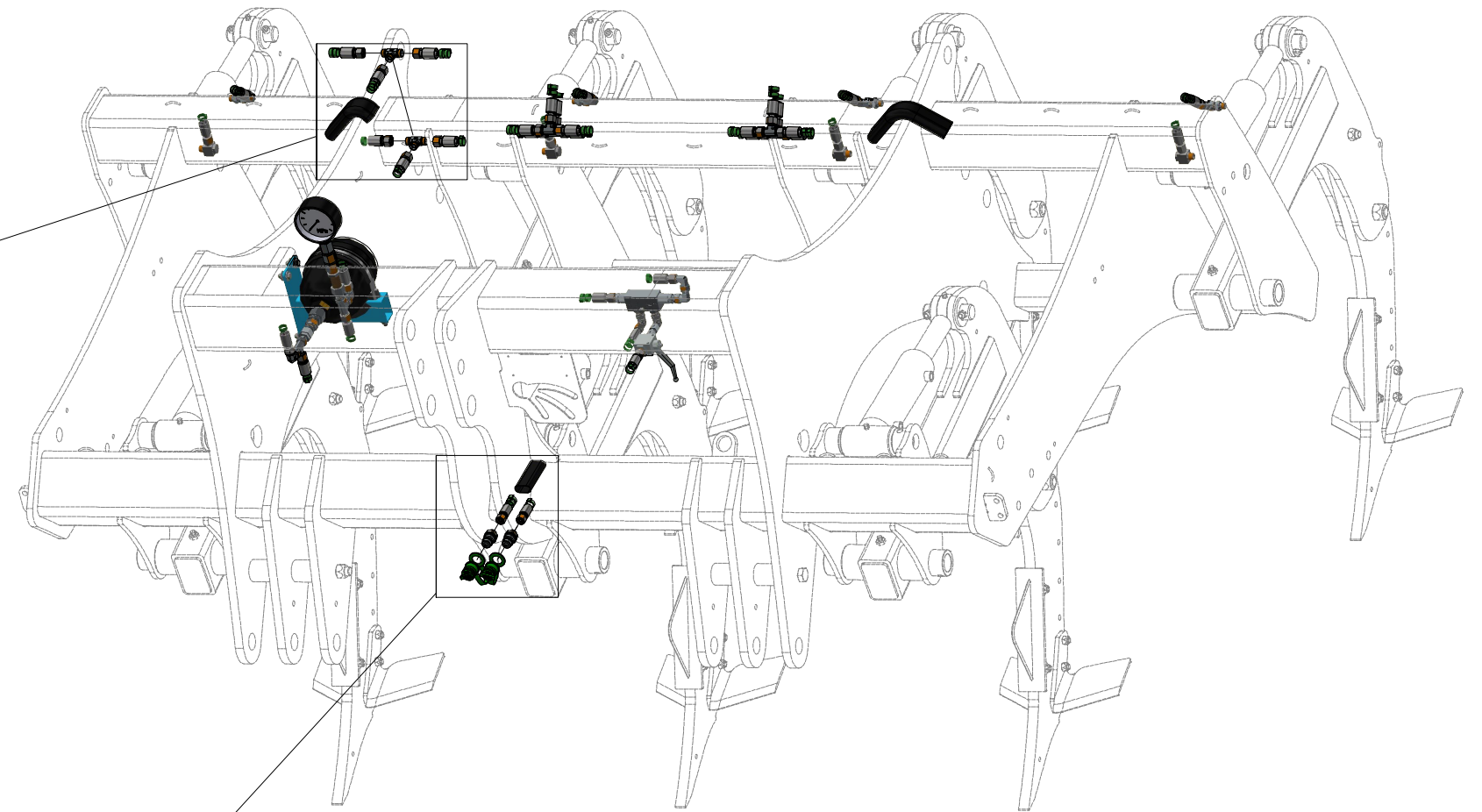
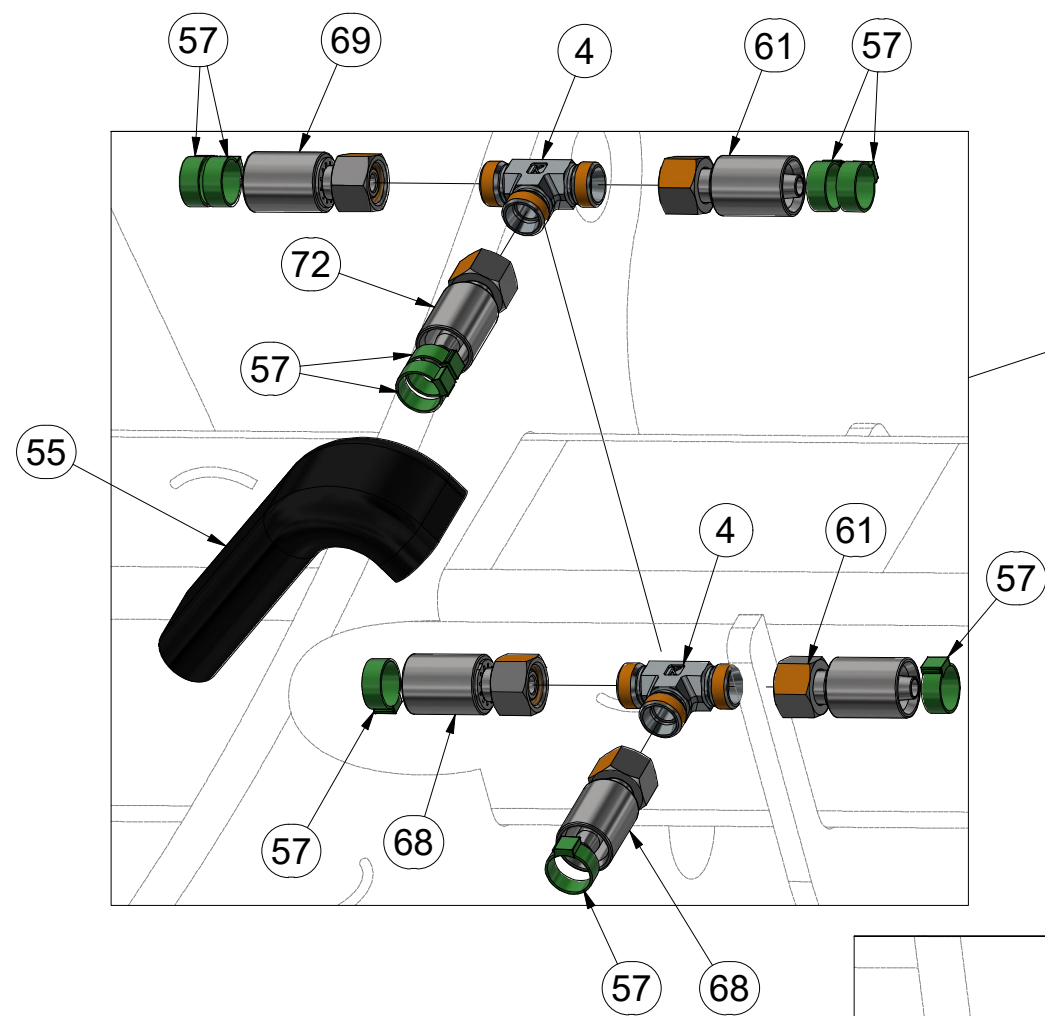

Pos.	Part Number	Pcs.	Pos.	Part Number	Pcs.
4	m02632	9	68	m15584	3
45	m03849	4	69	m04999	2
51	m04098	2	72	m02994	1
55	m11183	6	80	m07360	2
57	m11282	52	81	m05762	2
61	m13237	2			

ⒸZ HYDRAULIKA STROJE

Ⓓ HYDRAULIK DER MASCHINE

Ⓕ HYDRAULIQUE DE LA MACHINE

ⒸB MACHINE HYDRAULICS

ⒸU ГИДРАВЛИКА МАШИНЫ

ⒸL HYDRAULIKA MASZYNY



VZ00010551

Pos.	Part Number	Pcs.
4	m02632	9
55	m11183	6
57	m11282	52
61	m13237	2
64	m15583	3
65	m07505	2
66	m15580	3
70	m15585	1
71	m15579	2

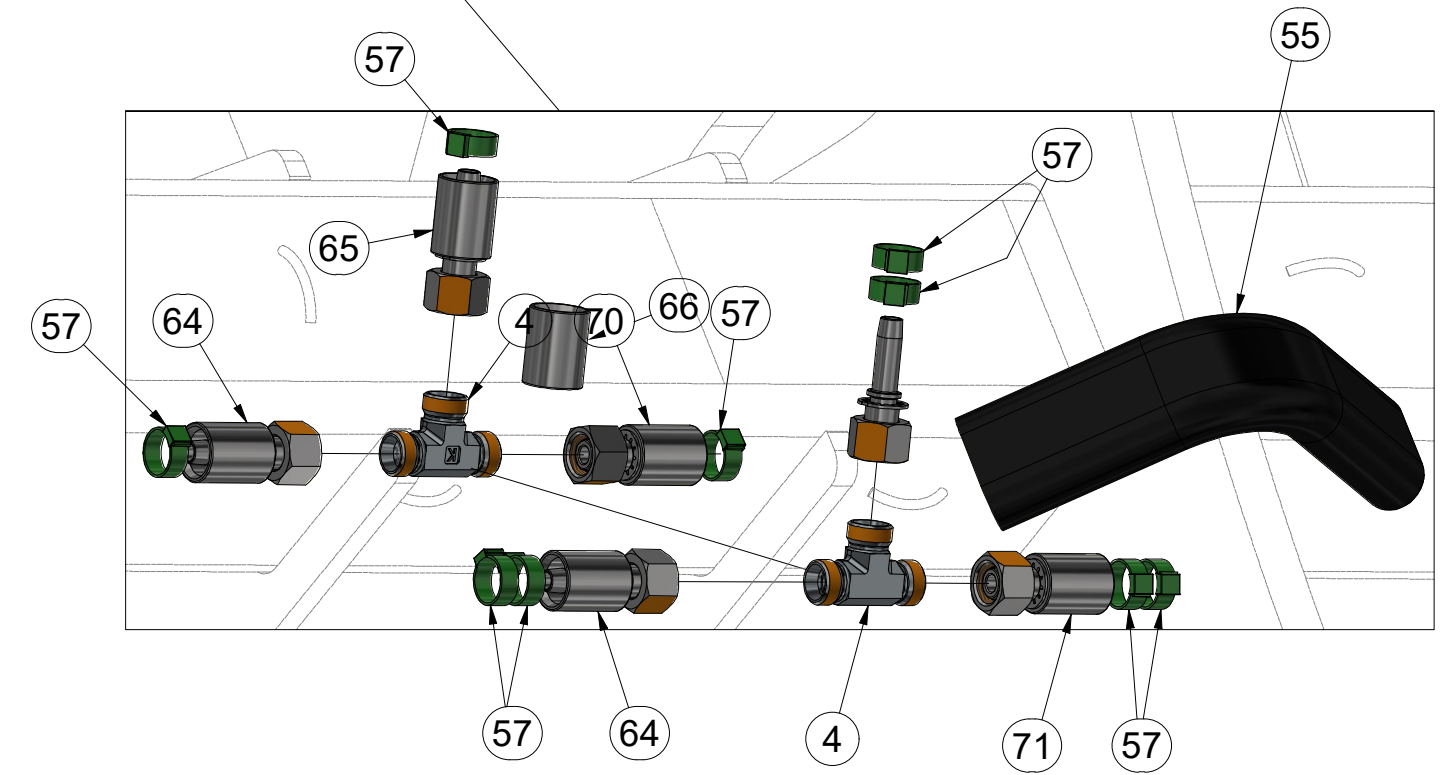
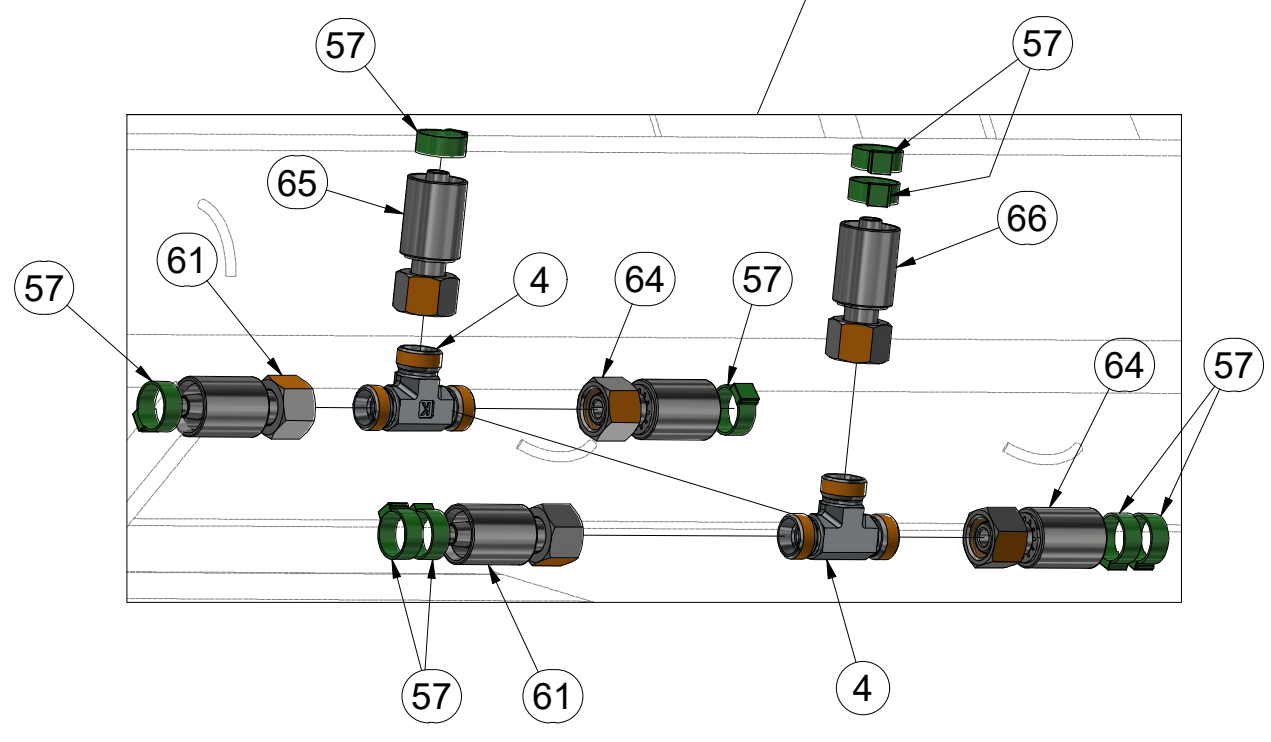
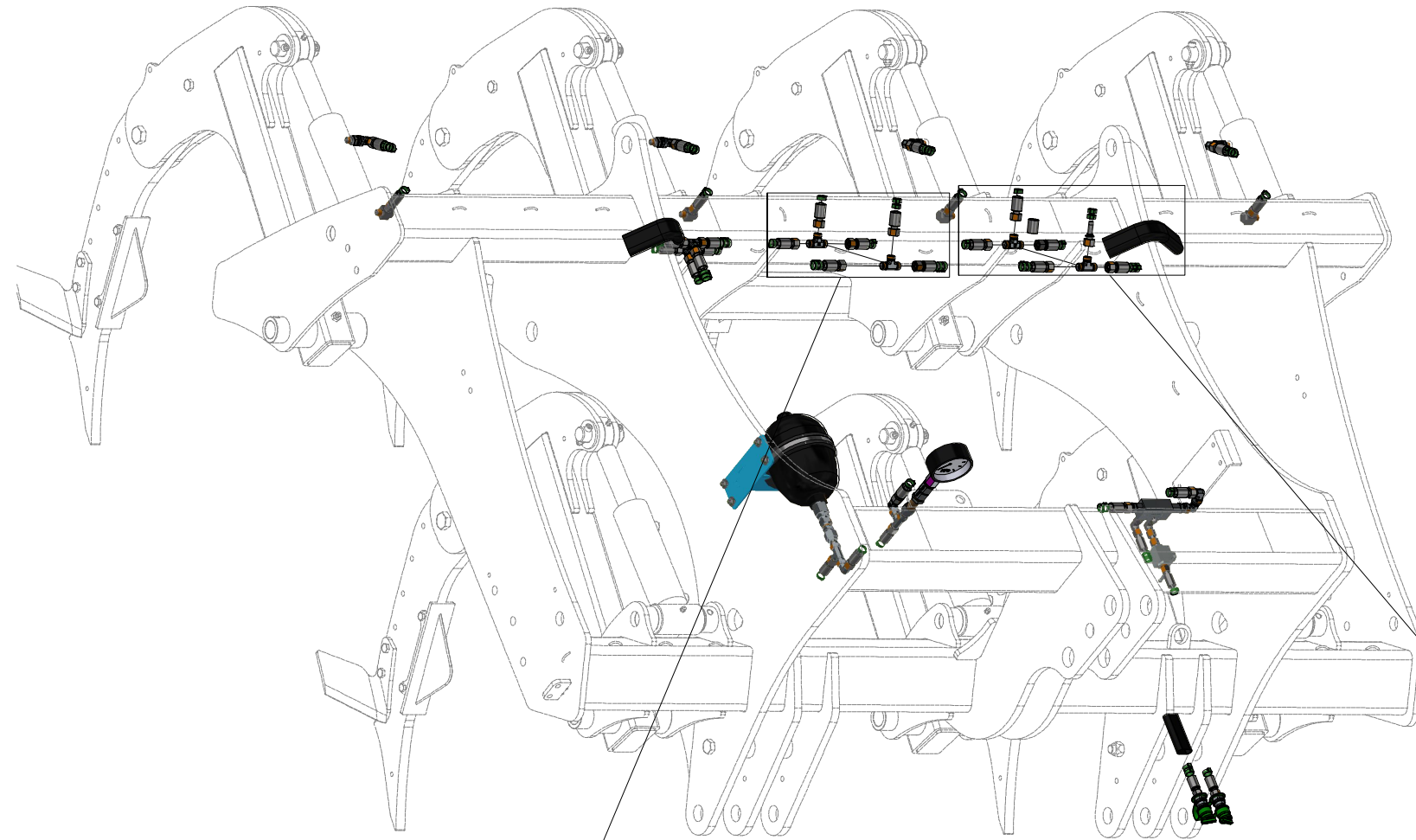

ⒸZ HYDRAULIKA STROJE

Ⓓ HYDRAULIK DER MASCHINE

Ⓕ HYDRAULIQUE DE LA MACHINE

ⒼB MACHINE HYDRAULICS

Ⓔ RU ГИДРАВЛИКА МАШИНЫ

Ⓗ PL HYDRAULIKA MASZYNY



VZ00010551

Pos.	Part Number	Pcs.
1	m20882	4
7	m07654	17
19	m10097	10
57	m11282	52
65	m07505	2
66	m15580	3
68	m15584	3
69	m04999	2
70	m15585	1
71	m15579	2

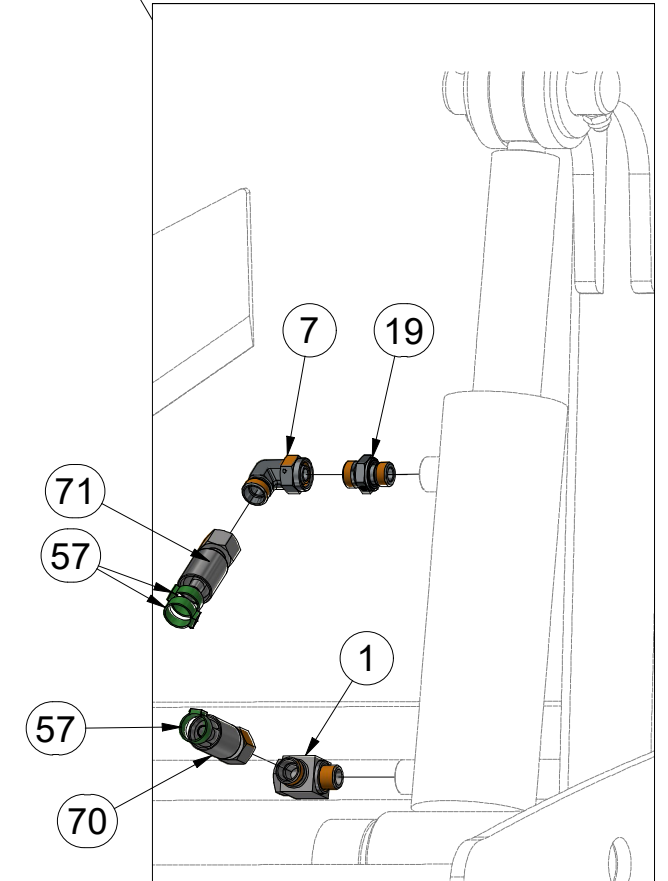
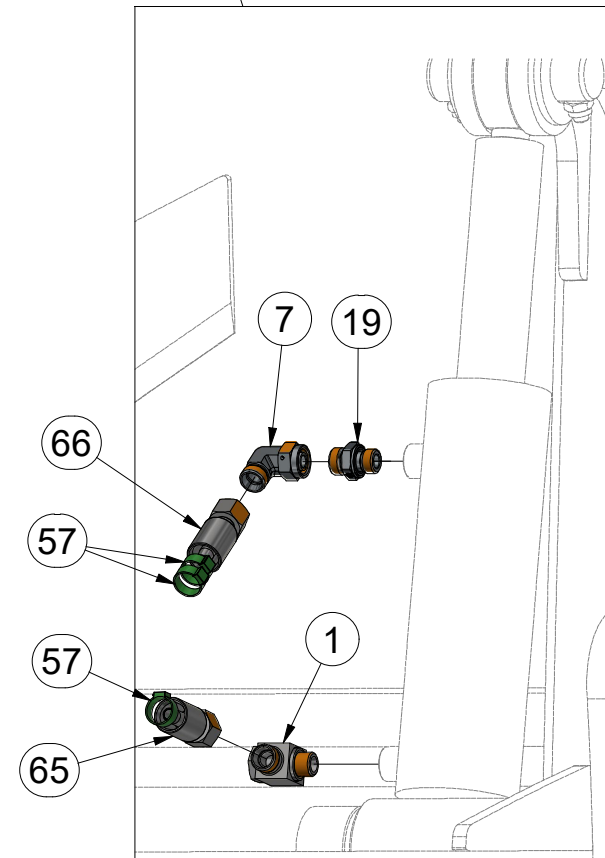
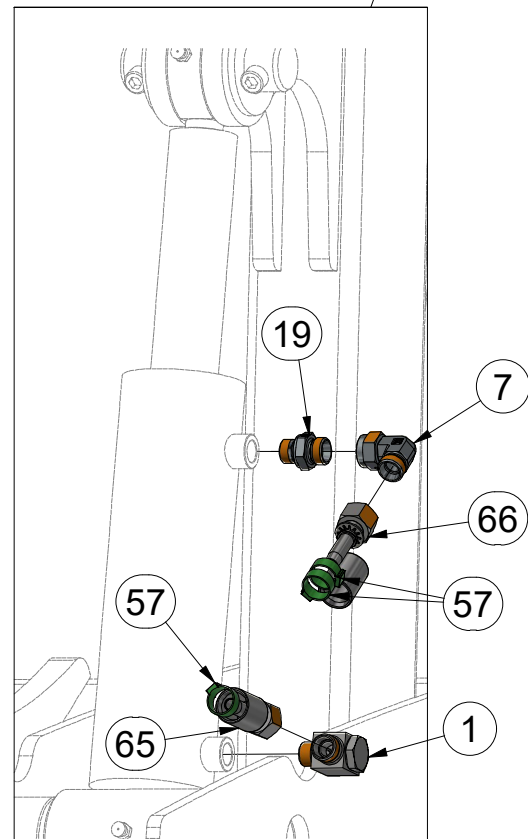
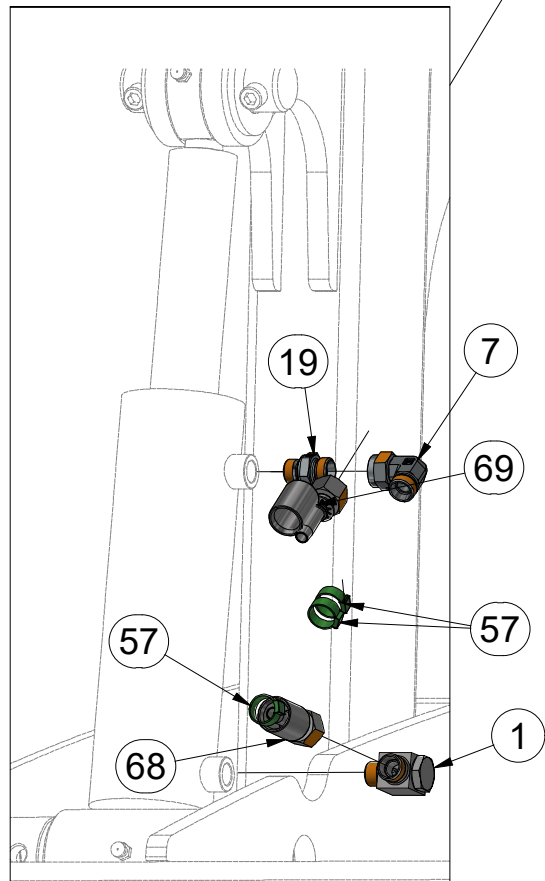
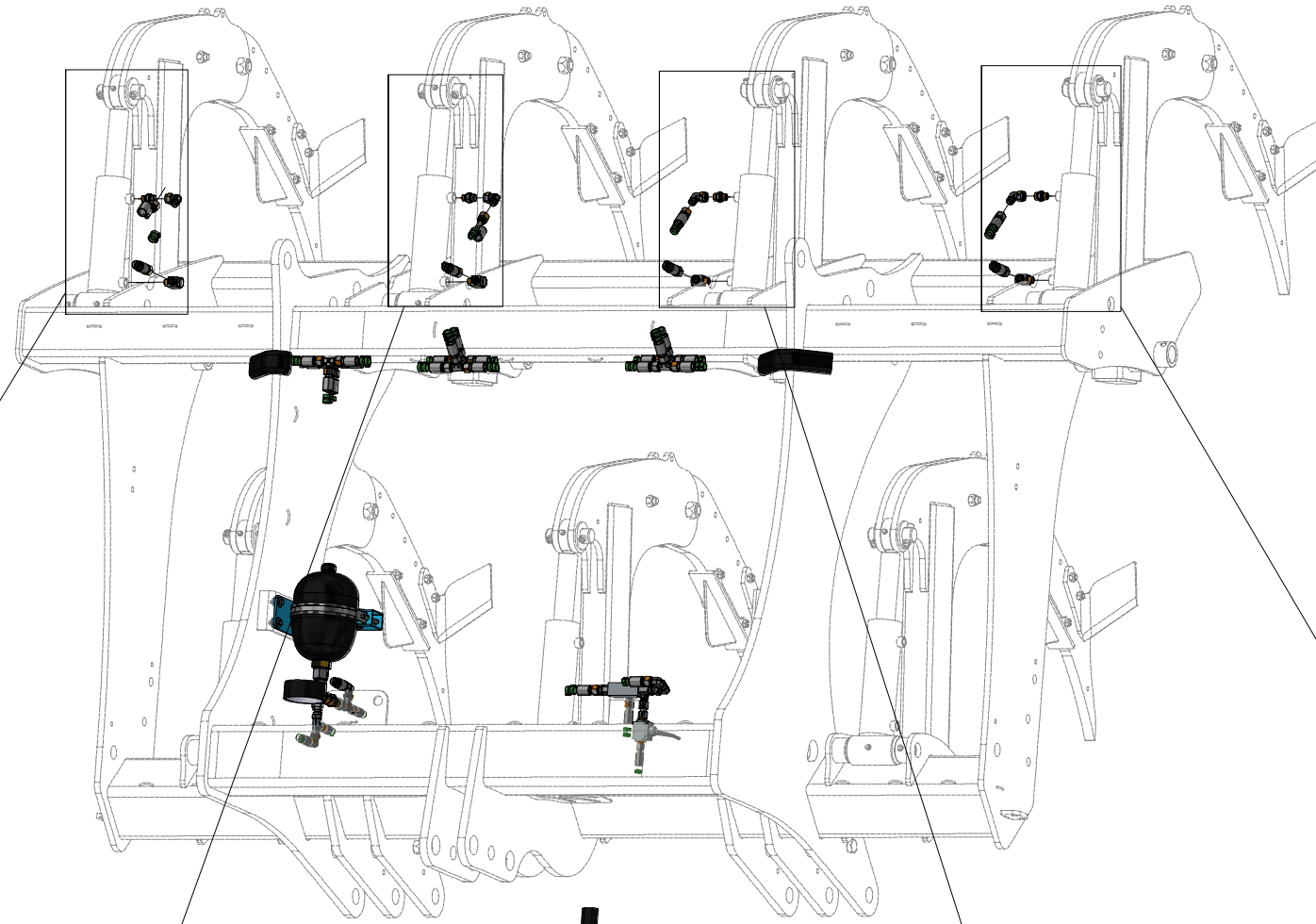

VZ00010551

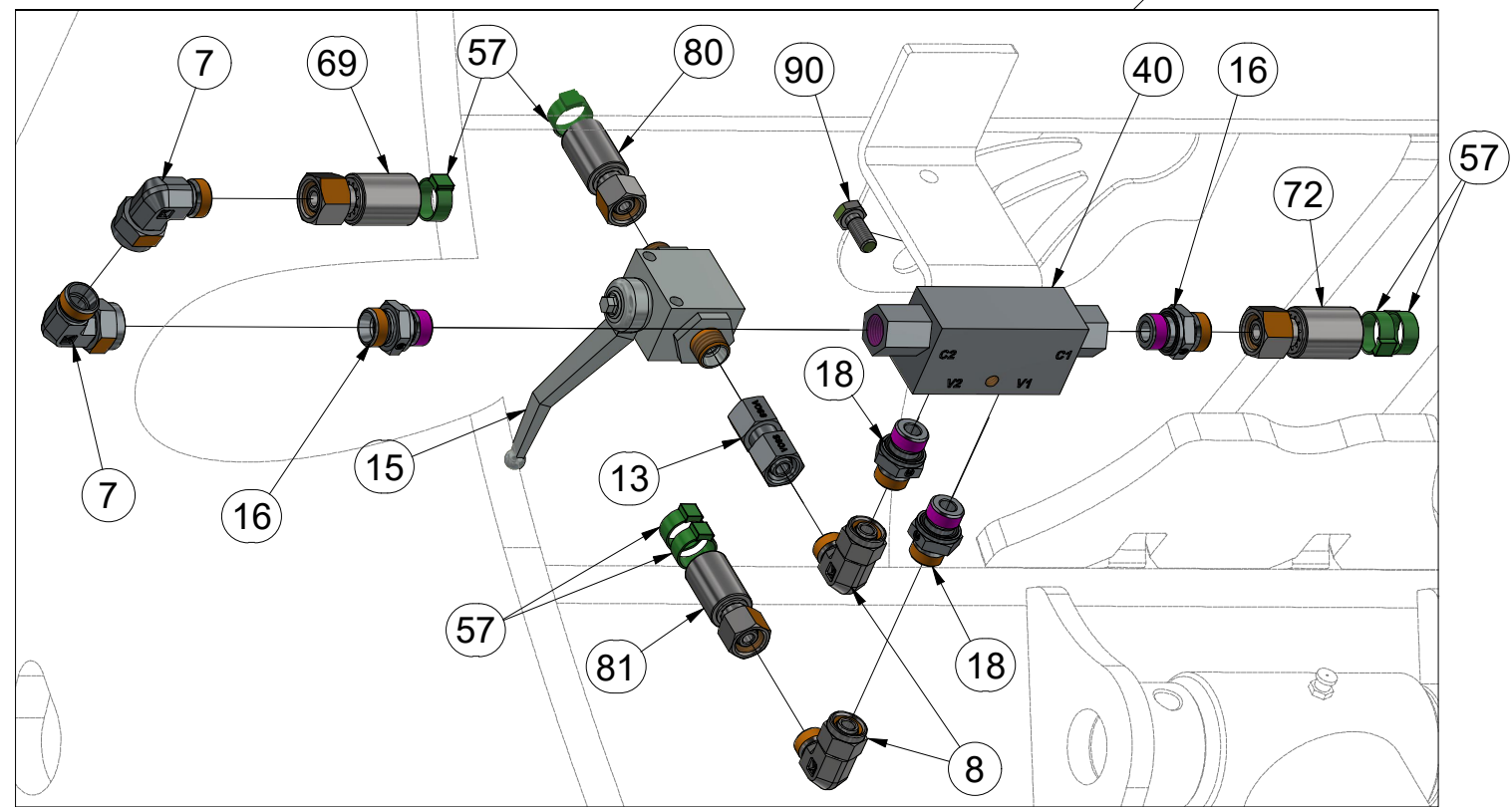
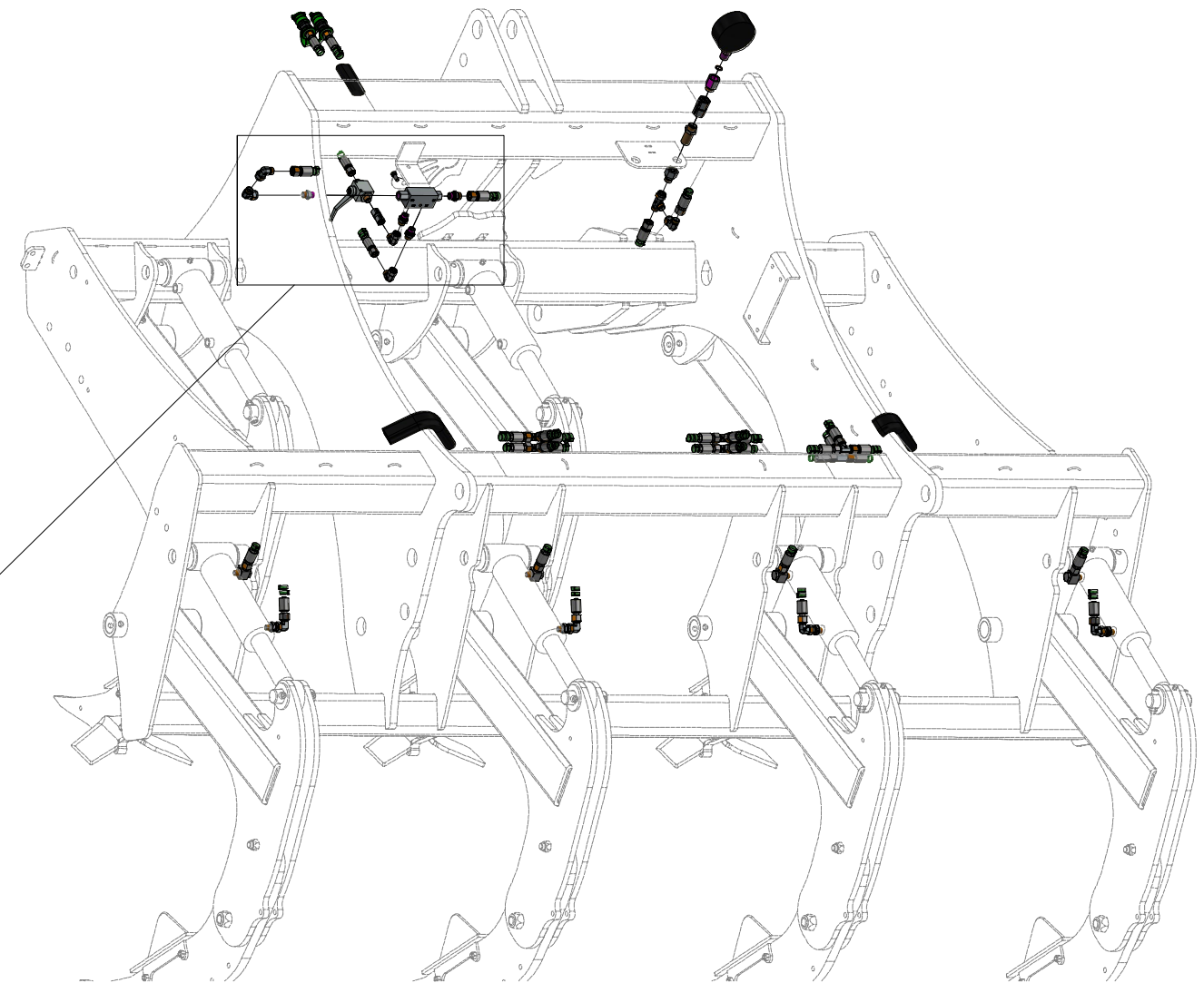

Pos.	Part Number	Pcs.	Pos.	Part Number	Pcs.
7	m07654	17	57	m11282	52
8	m06803	2	69	m04999	2
13	m22305	2	72	m02994	1
15	m04623	2	80	m07360	2
16	m06320	4	81	m05762	2
18	m06528	4	90	m01089	2
40	m11103	2			

Ⓒ HYDRAULIKA STROJE

Ⓓ HYDRAULIK DER MASCHINE

Ⓕ HYDRAULIQUE DE LA MACHINE

Ⓖ MACHINE HYDRAULICS

Ⓡ ГИДРАВЛИКА МАШИНЫ

Ⓟ HYDRAULIKA MASZYN



VZ00010551

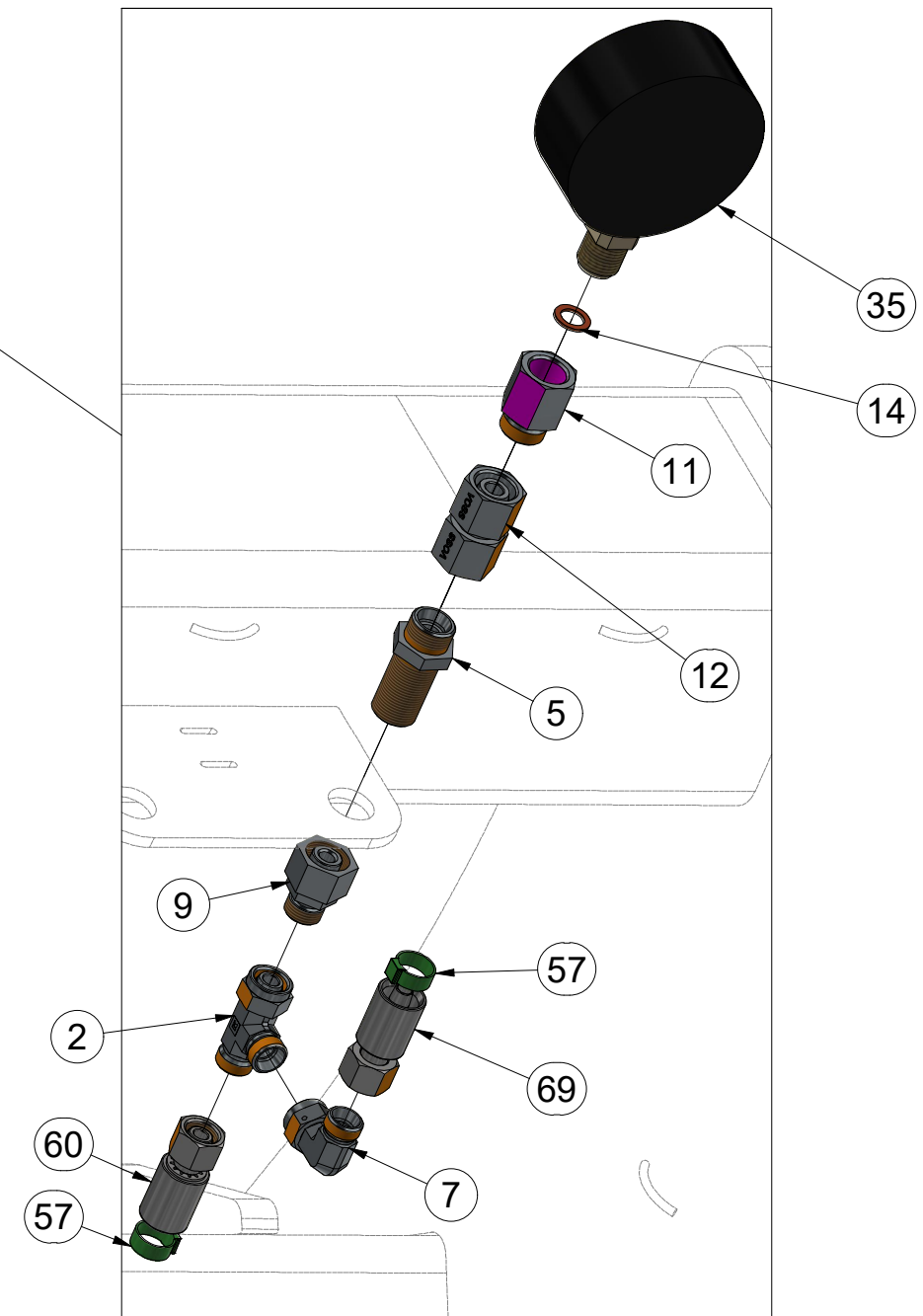
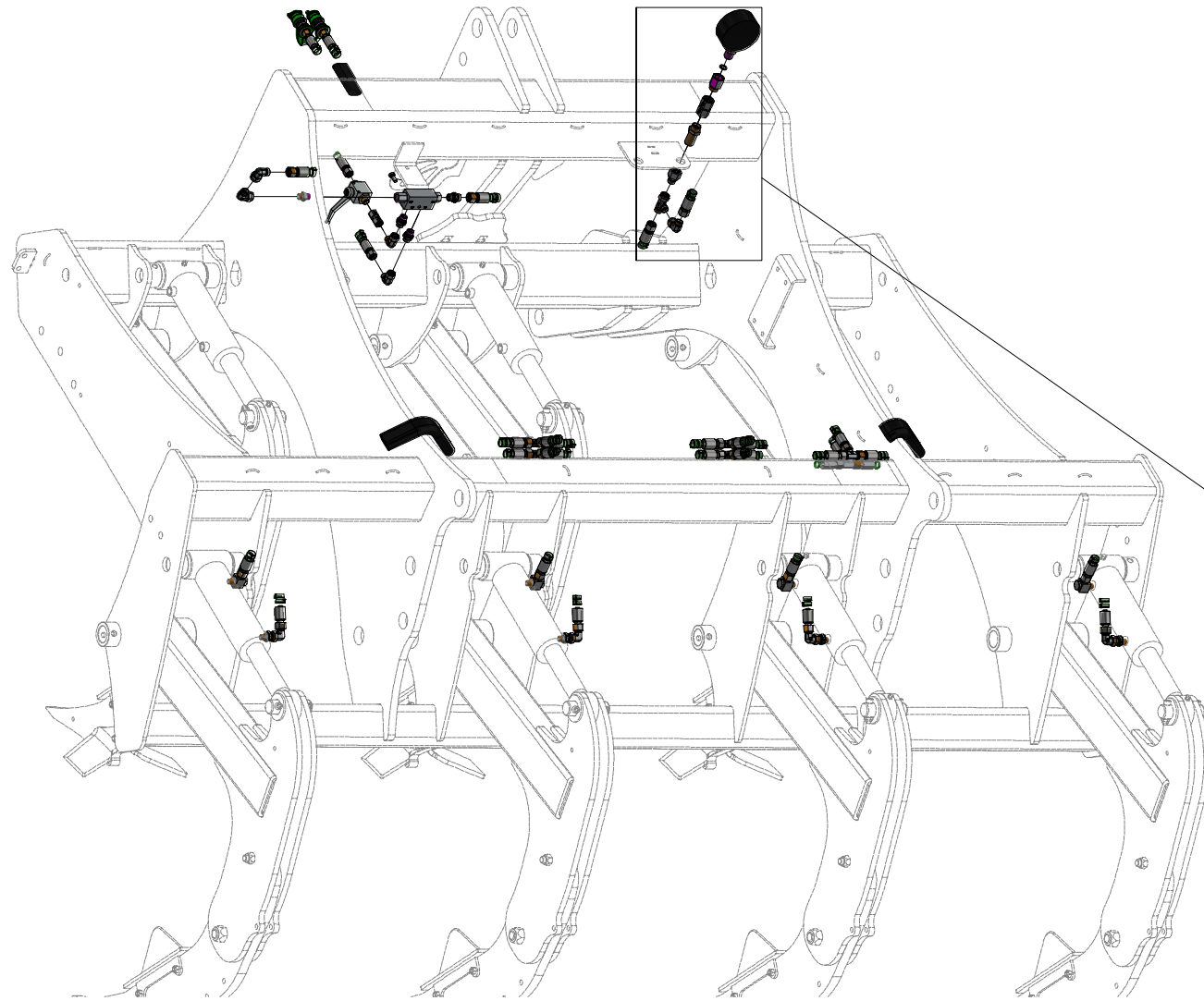

Pos.	Part Number	Pcs.	Pos.	Part Number	Pcs.
2	m08299	4	14	m04320	2
5	m09625	2	35	m05518	2
7	m07654	17	57	m11282	52
9	m09987	4	60	m10830	2
11	m11974	2	69	m04999	2
12	m22307	2			

Ⓒ HYDRAULIKA STROJE

Ⓓ HYDRAULIK DER MASCHINE

Ⓕ HYDRAULIQUE DE LA MACHINE

Ⓖ MACHINE HYDRAULICS

Ⓡ ГИДРАВЛИКА МАШИНЫ

Ⓟ HYDRAULIKA MASZYNY



VZ00010551

Pos.	Part Number	Pcs.	Pos.	Part Number	Pcs.
2	m08299	4	17	m07993	2
6	m04428	2	25	m21541	2
7	m07654	17	30	VZ00025939	2
9	m09987	4	57	m11282	52
10	m13037	2	60	m10830	2
			68	m15584	3

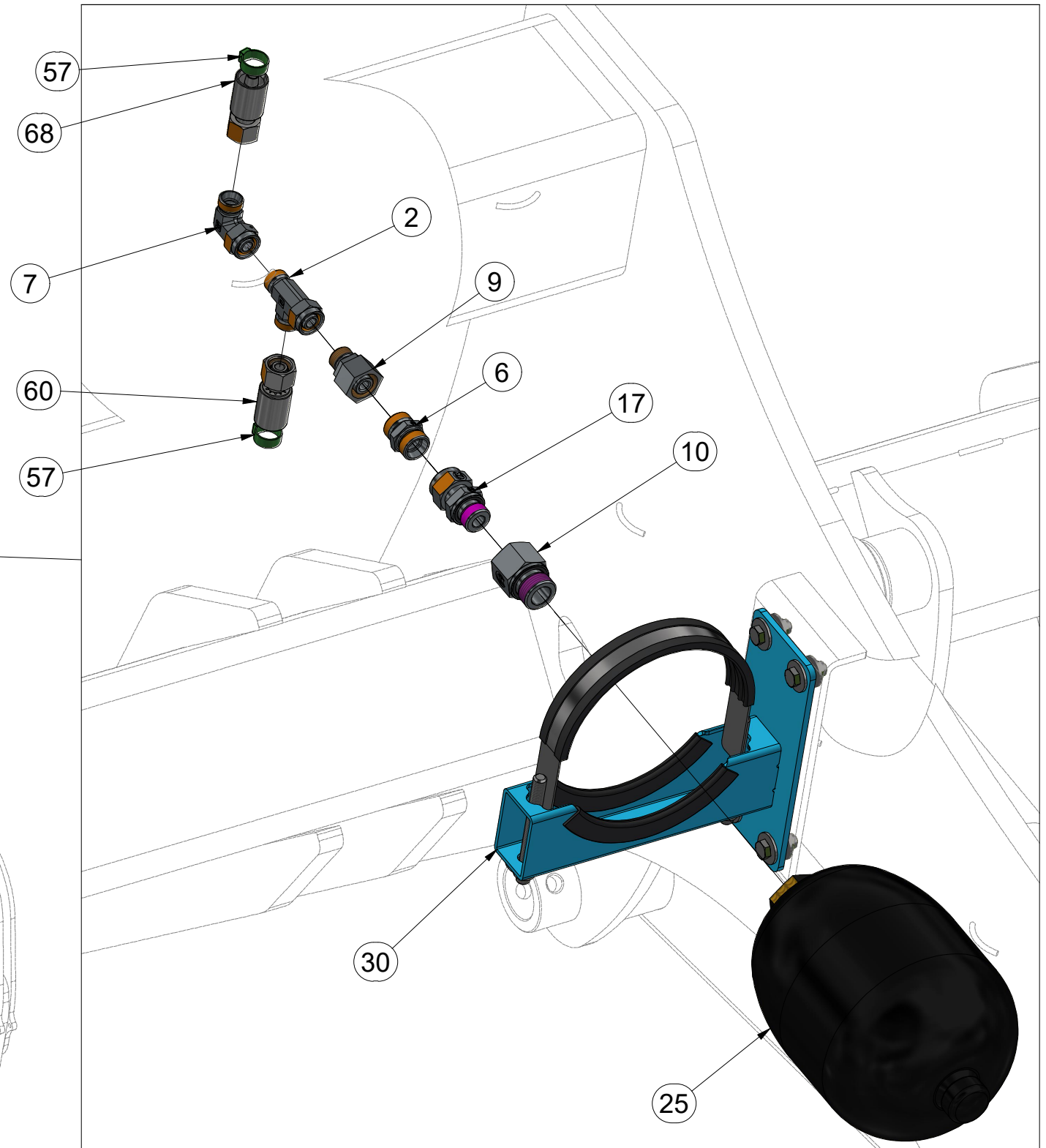
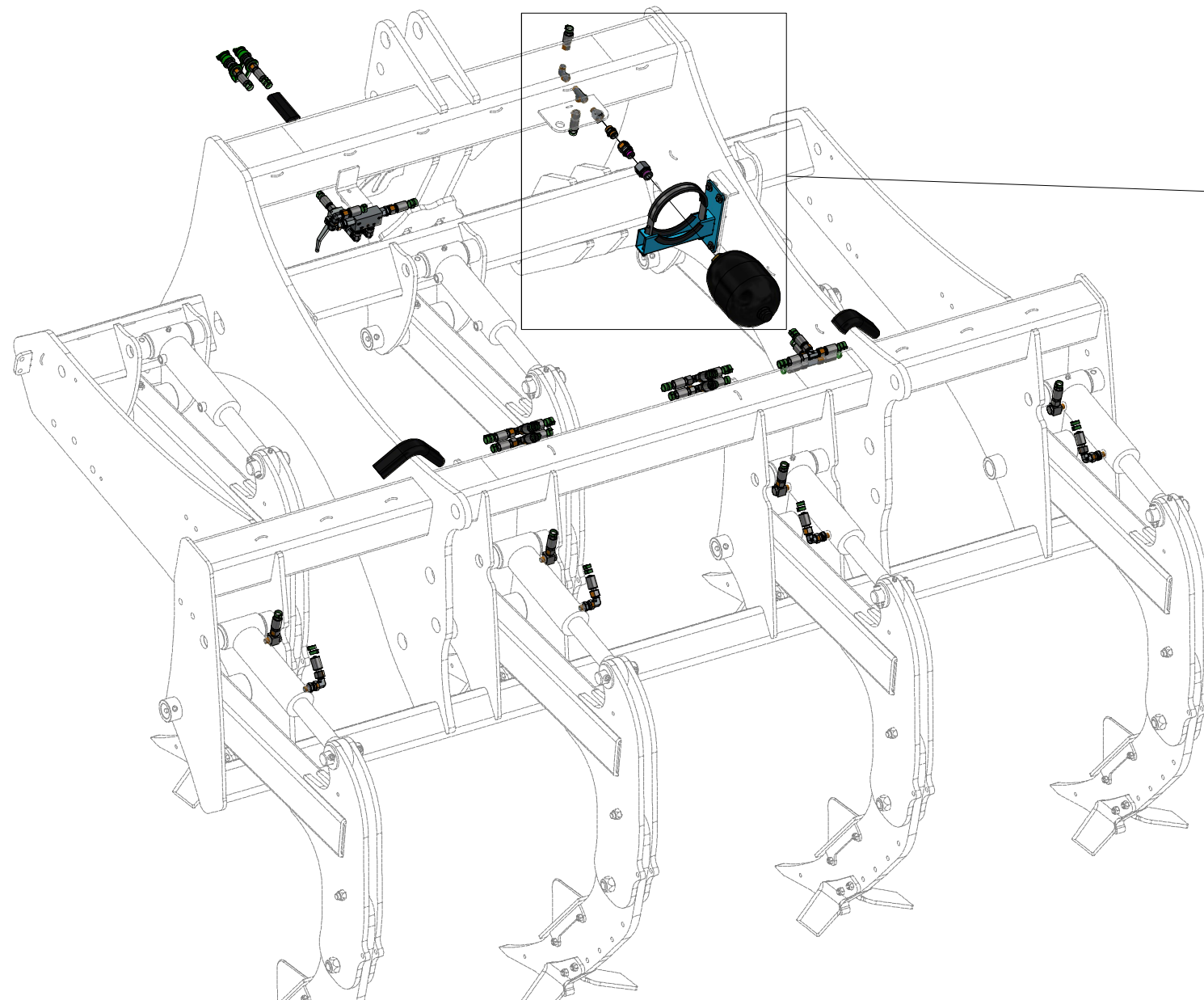

Ⓒ DRŽÁK AKUMULÁTORU

Ⓓ BATERIEHALTER

Ⓕ SUPPORT DE BATTERIE

VZ00025939

Ⓖ BATTERY HOLDER

Ⓡ ДЕРЖАТЕЛЬ БАТАРЕИ

Ⓢ UCHWYT BATERII

Farmet

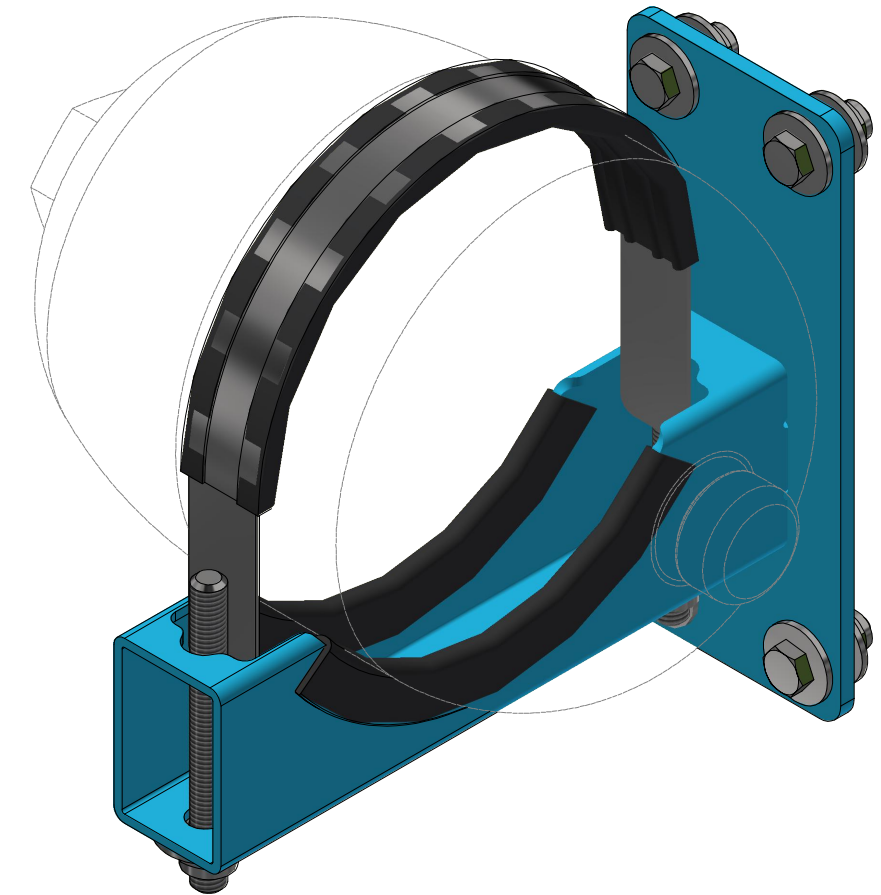
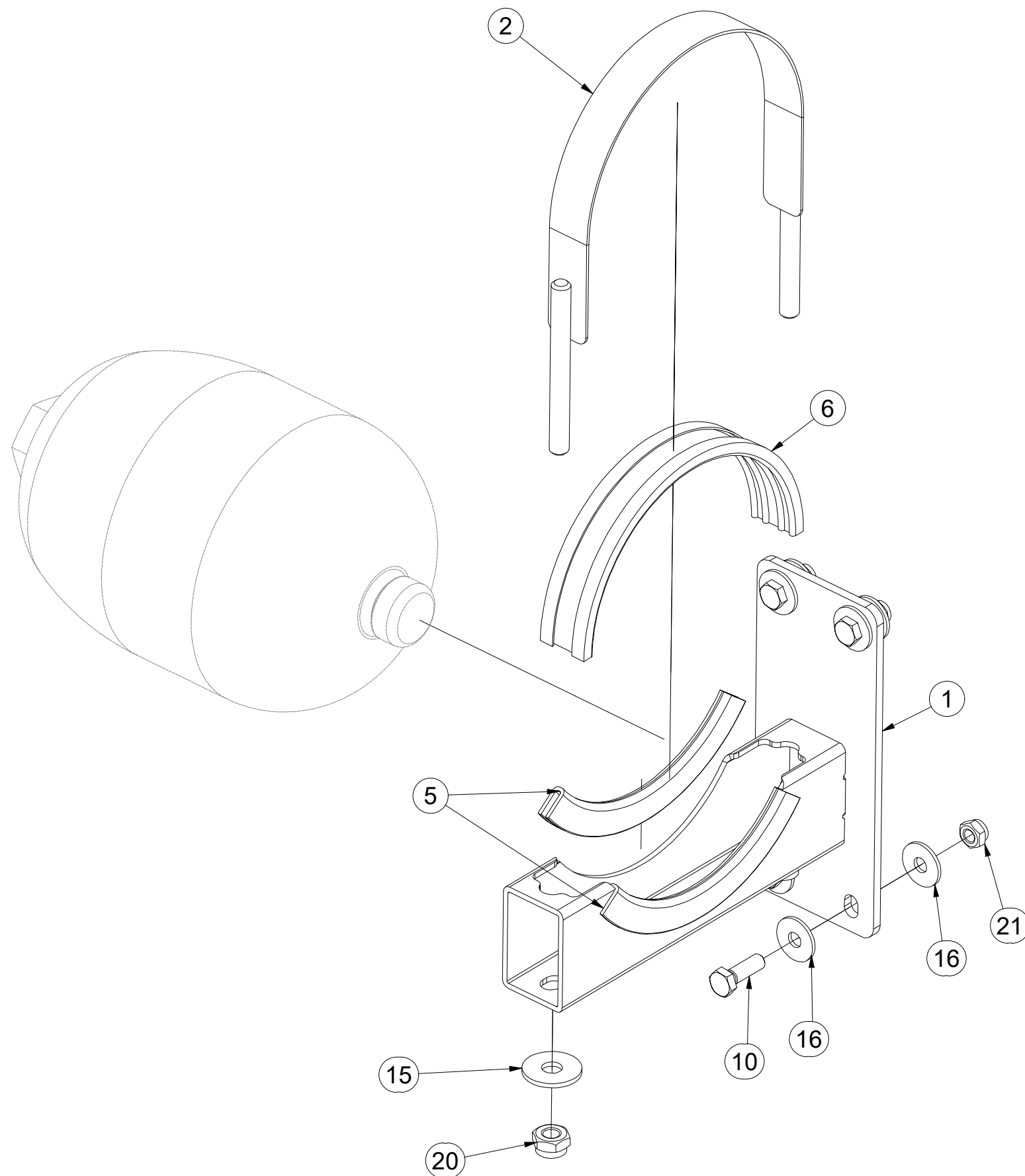

Pos.	Part Number	Pcs.
1	VZ00017130	1
2	VZ00017146	1
5	VZ00017174	2
6	VZ00017190	1
10	m01092	4
15	m16981	2
16	m07936	8
20	m03775	2
21	m04503	4

Ⓒ HYDRAULIKA STROJE

Ⓓ HYDRAULIK DER MASCHINE

Ⓕ HYDRAULIQUE DE LA MACHINE

VZ00021582

Ⓖ MACHINE HYDRAULICS

Ⓡ ГИДРАВЛИКА МАШИНЫ

Ⓟ HYDRAULIKA MASZYN

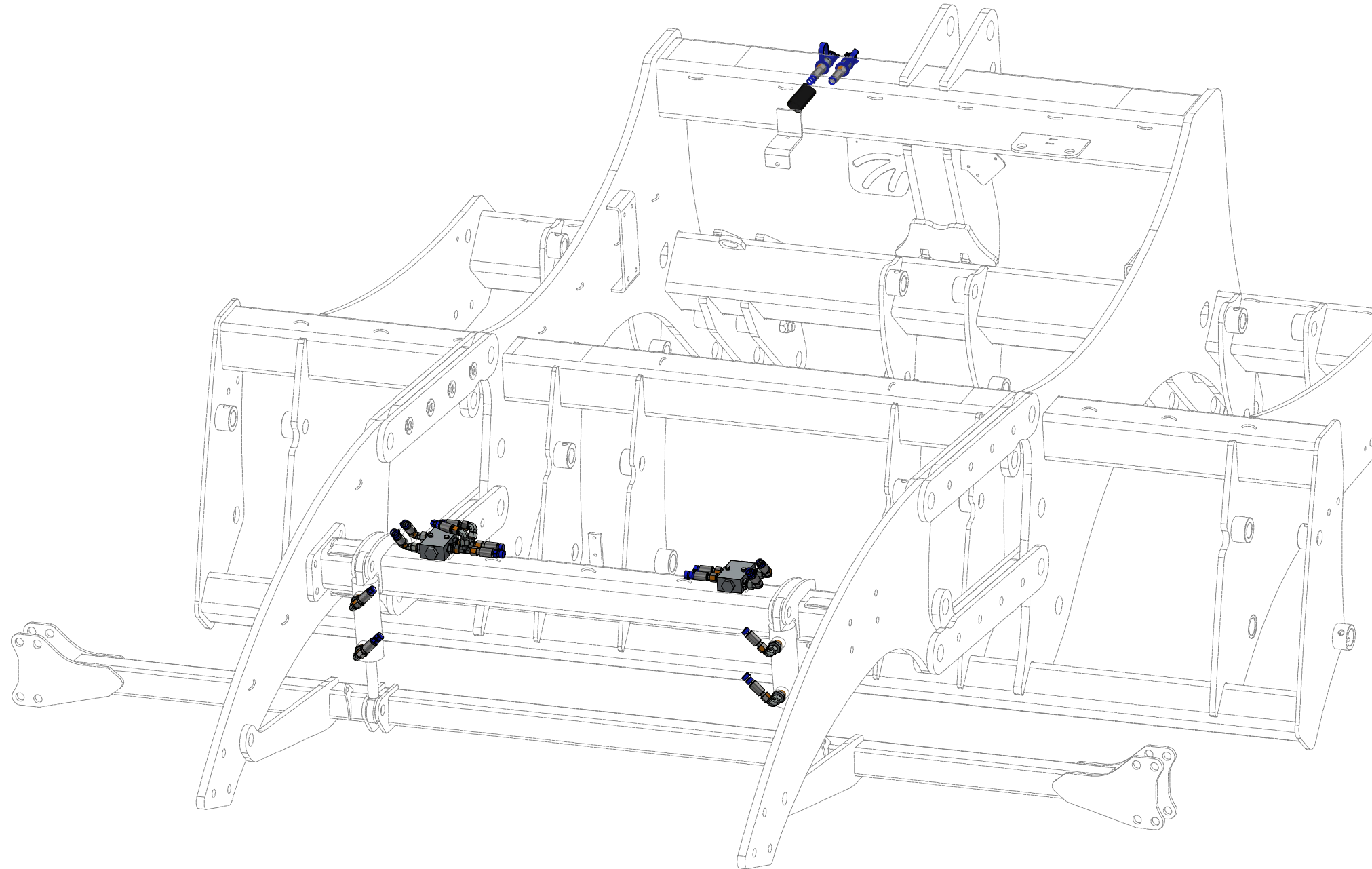

VZ00021582

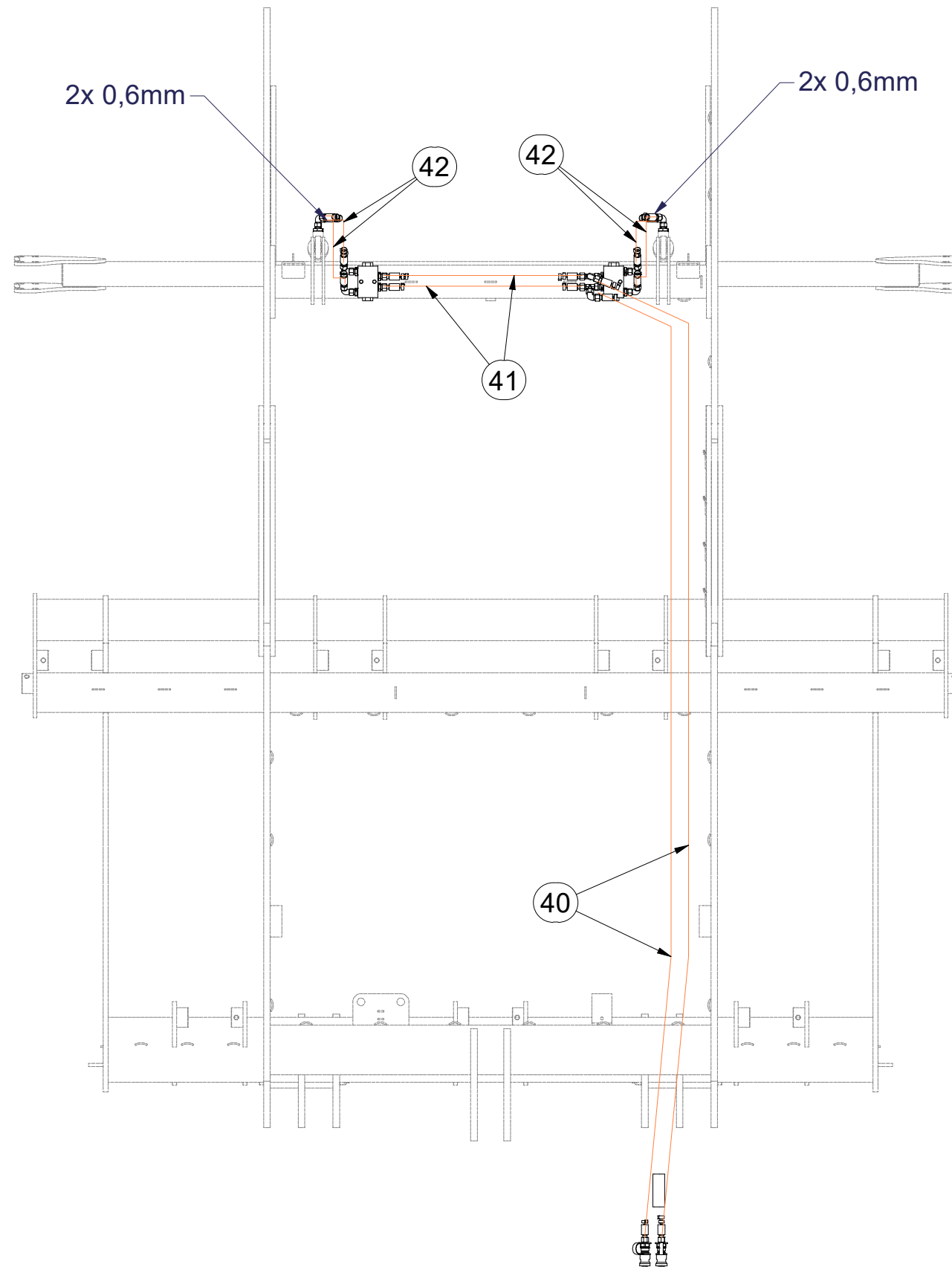

Pos.	Part Number	Pcs.
40	m04087	2
41	m03713	2
42	m09627	4

ⒸZ HYDRAULIKA STROJE

Ⓓ HYDRAULIK DER MASCHINE

Ⓕ HYDRAULIQUE DE LA MACHINE

ⒸB MACHINE HYDRAULICS

ⒸR ГИДРАВЛИКА МАШИНЫ

ⒸL HYDRAULIKA MASZYNY



VZ00021582

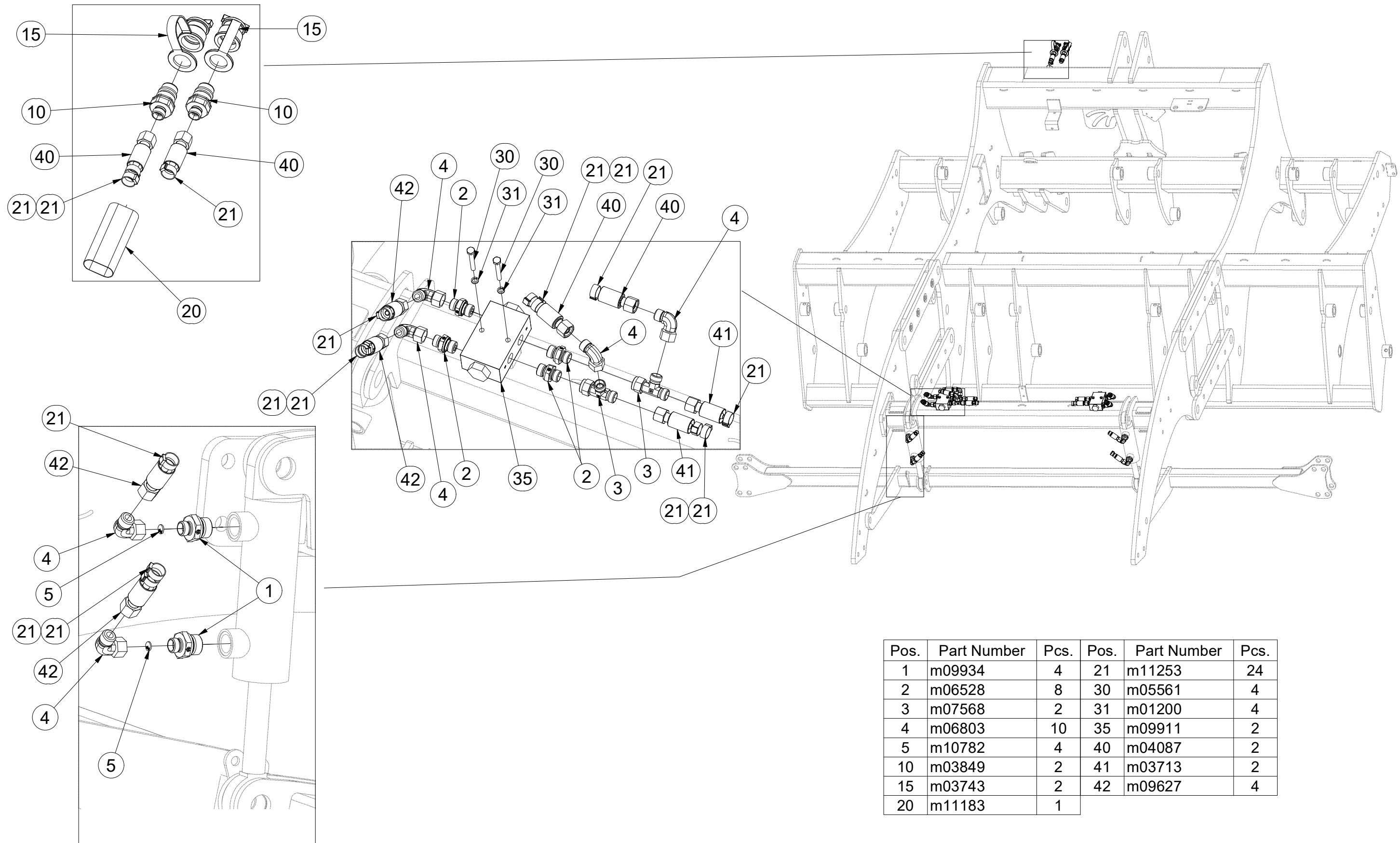

ⒸZ HYDRAULIKA STROJE

ⒸD HYDRAULIK DER MASCHINE

ⒸF HYDRAULIQUE DE LA MACHINE

ⒸB MACHINE HYDRAULICS

ⒸRU ГИДРАВЛИКА МАШИНЫ

ⒸPL HYDRAULIKA MASZYNY



VZ00021582

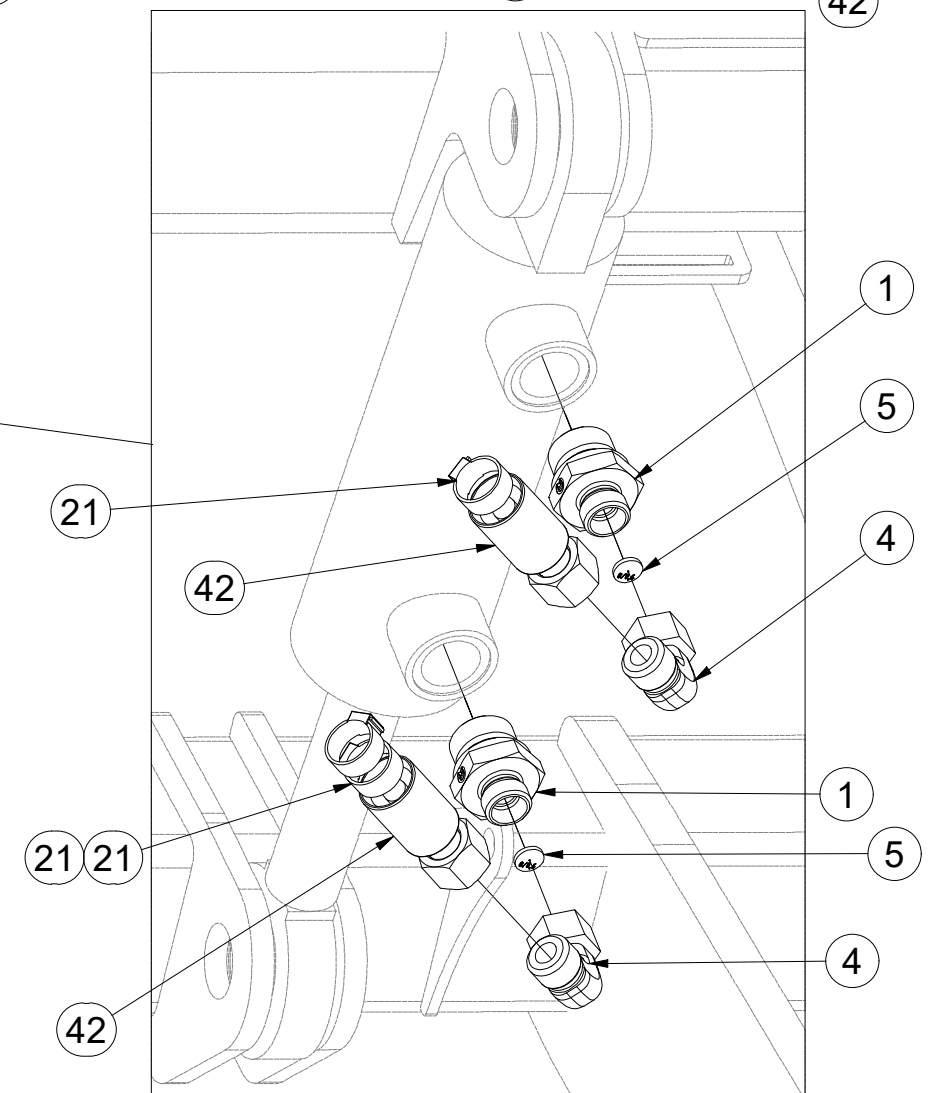
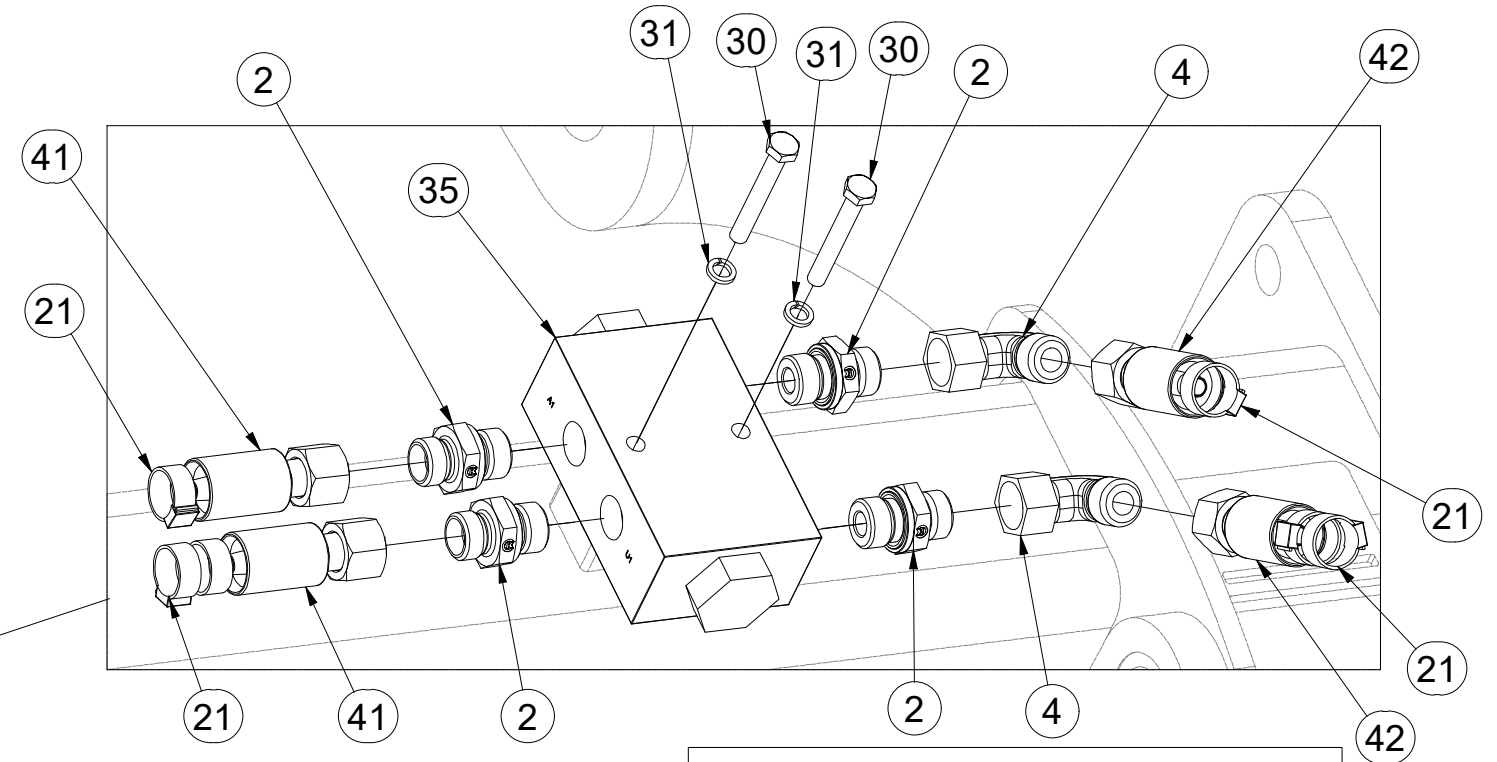
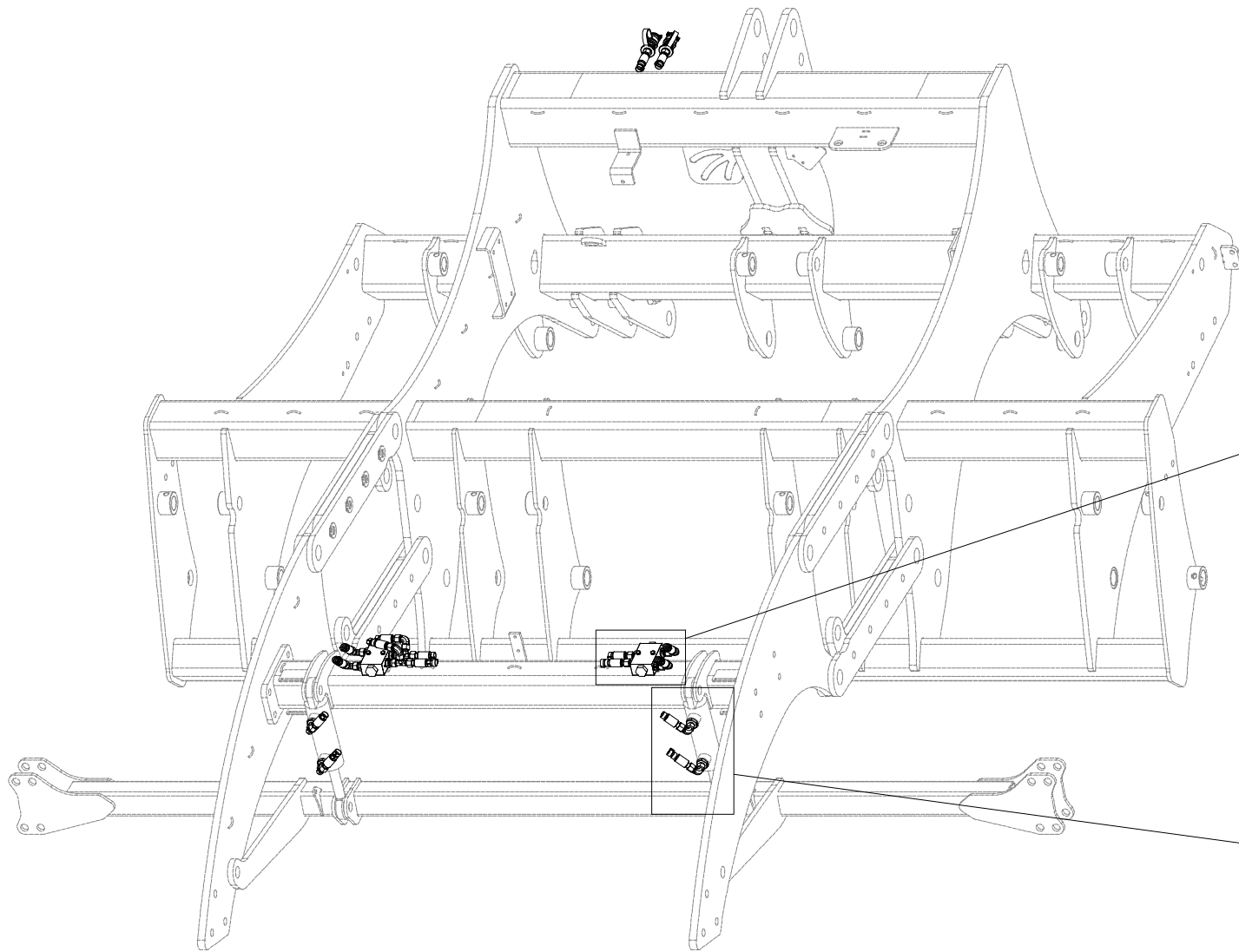

Pos.	Part Number	Pcs.
1	m09934	4
2	m06528	8
4	m06803	10
5	m10782	4
21	m11253	24
30	m05561	4
31	m01200	4
35	m09911	2
41	m03713	2
42	m09627	4

- Ⓒ DRŽÁK
- Ⓓ HALTER
- Ⓕ SUPPORT

- Ⓖ HOLDER
- Ⓡ ДЕРЖАТЕЛЬ
- Ⓢ UCHWYT



VZ00010412

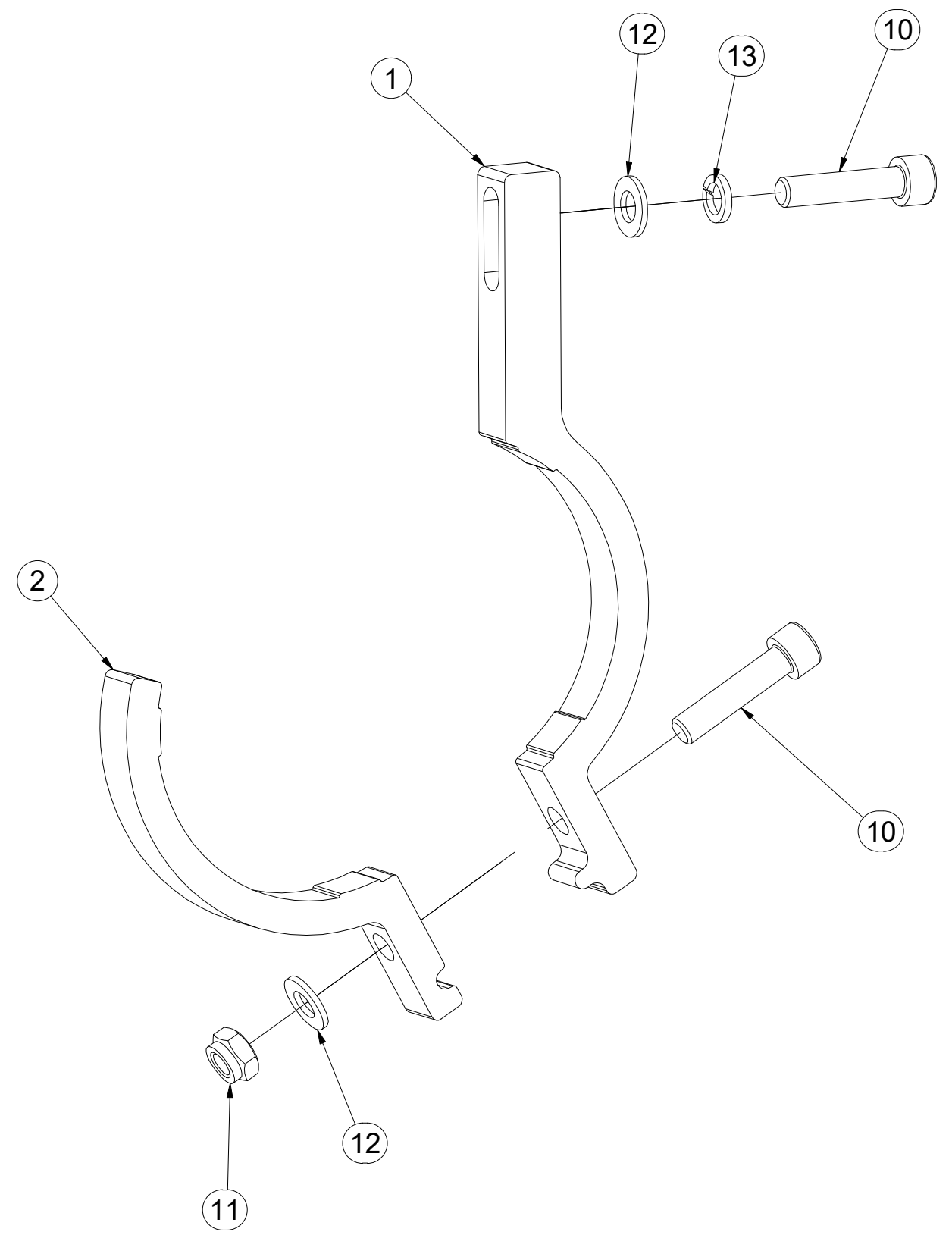

Pos.	Part Number	Pcs.
1	VZ00010413	1
2	VZ00010411	1
10	m09464	2
11	m04503	1
12	m01203	2
13	m01202	1

Ⓒ PÍSTNICE 80/45-200

Ⓓ KOLBENSTANGE 80/45-200

Ⓕ TIGE DE PISTON 80/45-200

Ⓖ PISTON ROD 80/45-200

Ⓡ ЦИЛИНДР 80/45-200

Ⓟ TRZPIEŃ TŁOKA 80/45-200



4013839

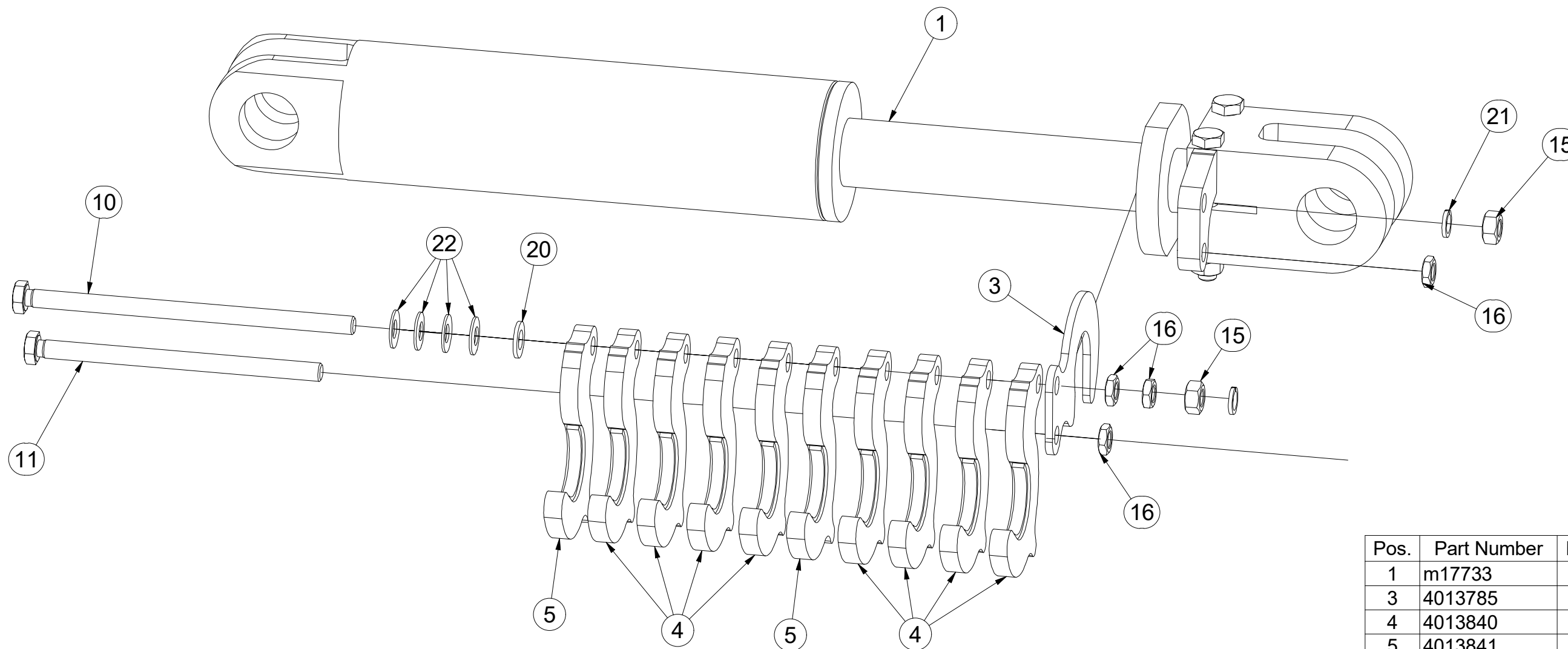

Pos.	Part Number	Pcs.
1	m17733	1
3	4013785	1
4	4013840	8
5	4013841	2
10	m14267	1
11	m15921	1
15	m01305	2
16	m14233	4
20	m01214	1
21	m03988	2
22	m17728	4

ⒸZ SOUPRAVA TĚSNIVA PÍSTNIC

Ⓓ KOLBENSTANGENDICHTUNGSMITTELSATZ

Ⓕ SET DE GARNITURE DES TIGES DE PISTON

ⒼB SEALING SET FOR PISTON RODS

ⒺU КОМПЛЕКТ ПРОКЛАДОК ЦИЛИНДРОВ

ⒻL ZESTAW USZCZELEK TRZPIENIA TŁOKA

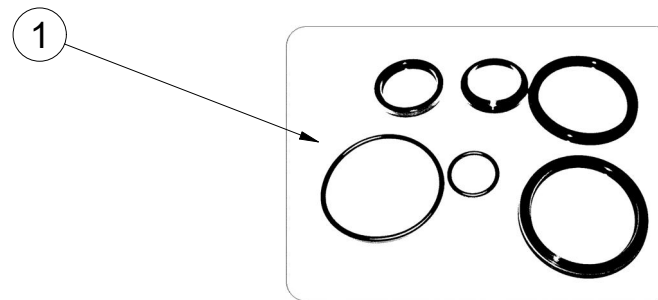
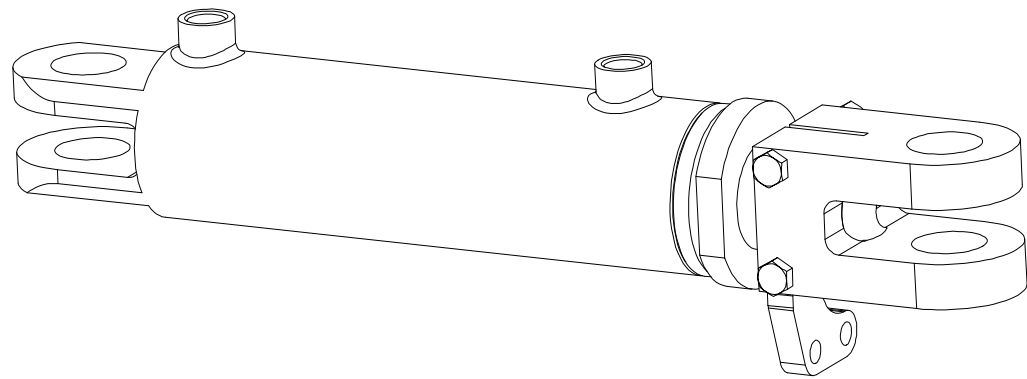

m17733 - $\varnothing 80/\varnothing 45-200$		
Pos	Part number	Pcs
1	m15373	2

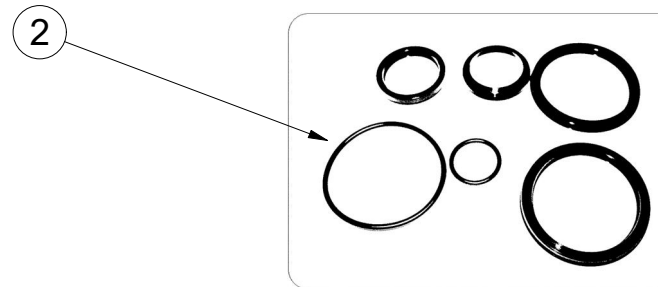
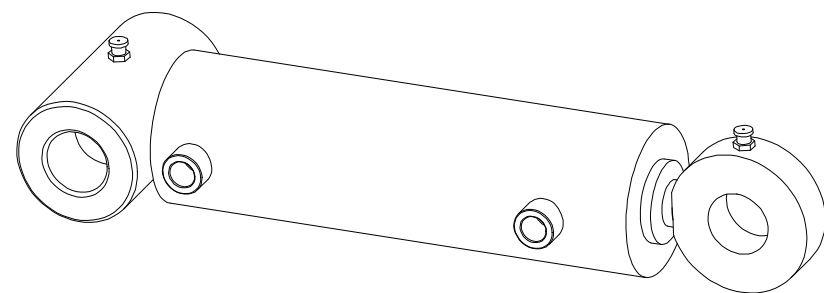

m21071 - $\varnothing 70/\varnothing 45-160$		
Pos	Part number	Pcs
2		7

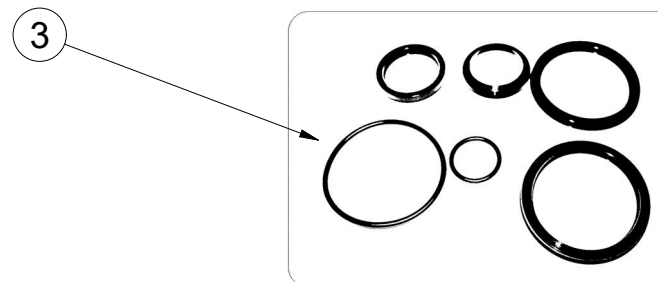
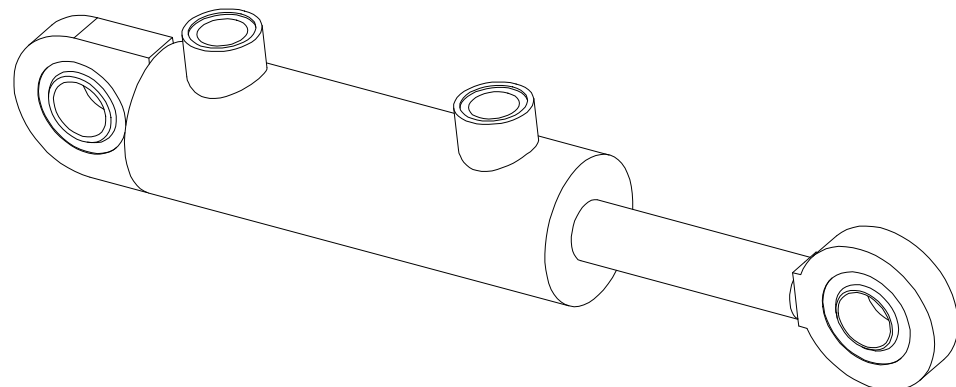

VZ00014803 - $\varnothing 50/\varnothing 25-100$		
Pos	Part number	Pcs
3	m08750	2

Ⓒ SAMOLEPKY STROJE

Ⓓ AUFKLEBER MASCHINEN

Ⓕ VOITURE MACHINES

Ⓖ STICKERS MACHINES

Ⓡ СТИКЕРЫ МАШИНЫ

Ⓟ NAKLEJKI MASZYN



m13190

Pos.	Part Number	Pcs.	Pos.	Part Number	Pcs.
1	m03315	2	12	m05312	2
2	m03316	4	13	m10353	2
3	m03320	14	14	m11147	6
5	m04359	1	15	m11297	4
6	m04360	1	16	m13084	1
7	m04361	1	17	m13085	1
8	m04363	2	18	m13091	1
9	m04366	1	20	m13117	4
10	m04368	2	21	m14308	2
11	m04609	1	22	m14830	2

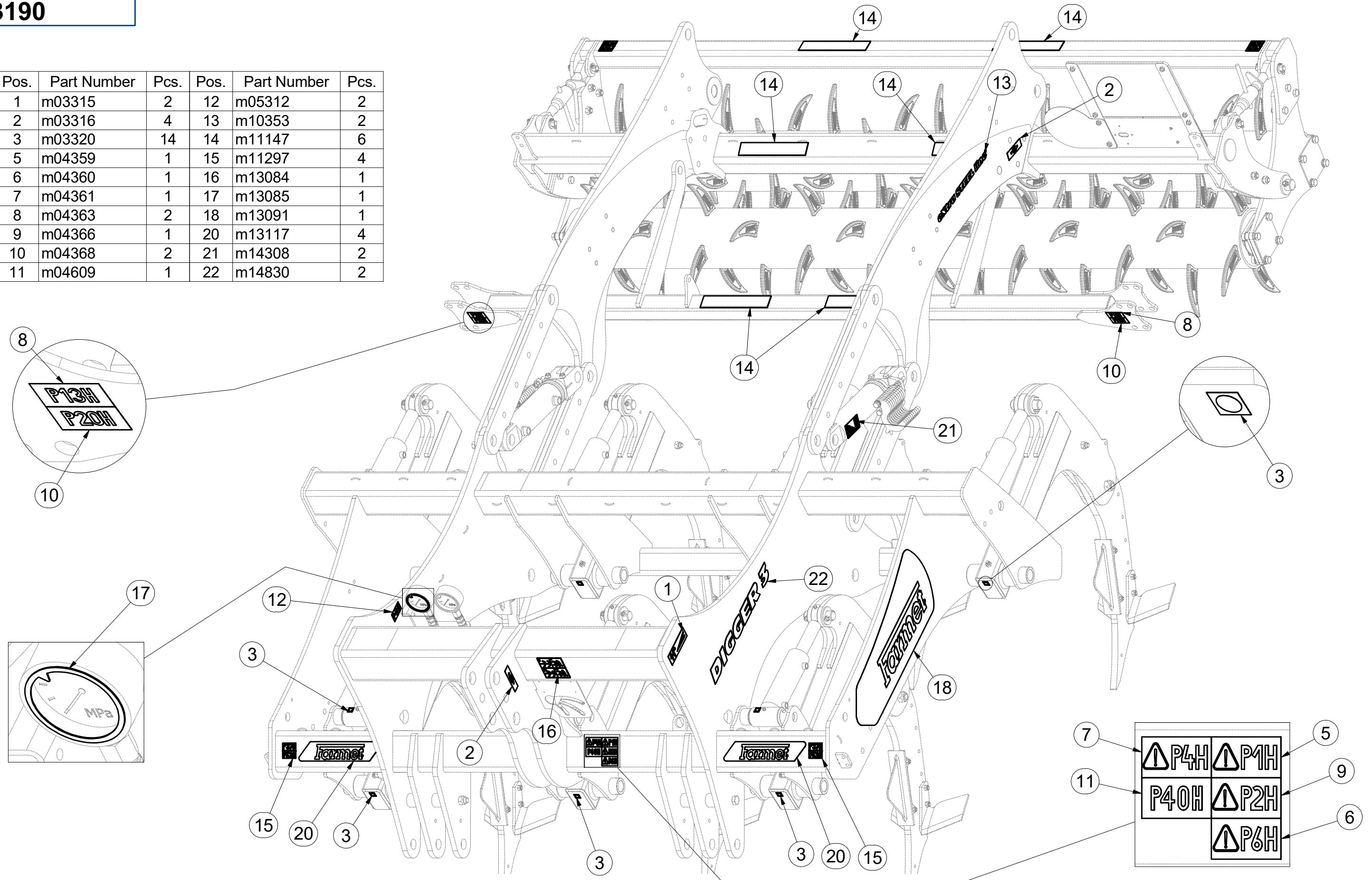

☉ SAMOLEPKY STROJE

☉ AUFKLEBER MASCHINEN

☉ VOITURE MACHINES

☉ STICKERS MACHINES

☉ СТИКЕРЫ МАШИНЫ

☉ NAKLEJKI MASZYNY



m13190

Pos.	Part Number	Pcs.
1	m03315	2
2	m03316	4
3	m03320	14
4	m03820	1
12	m05312	2
13	m10353	2
15	m11297	4
19	m13092	1
20	m13117	4
21	m14308	2
22	m14830	2

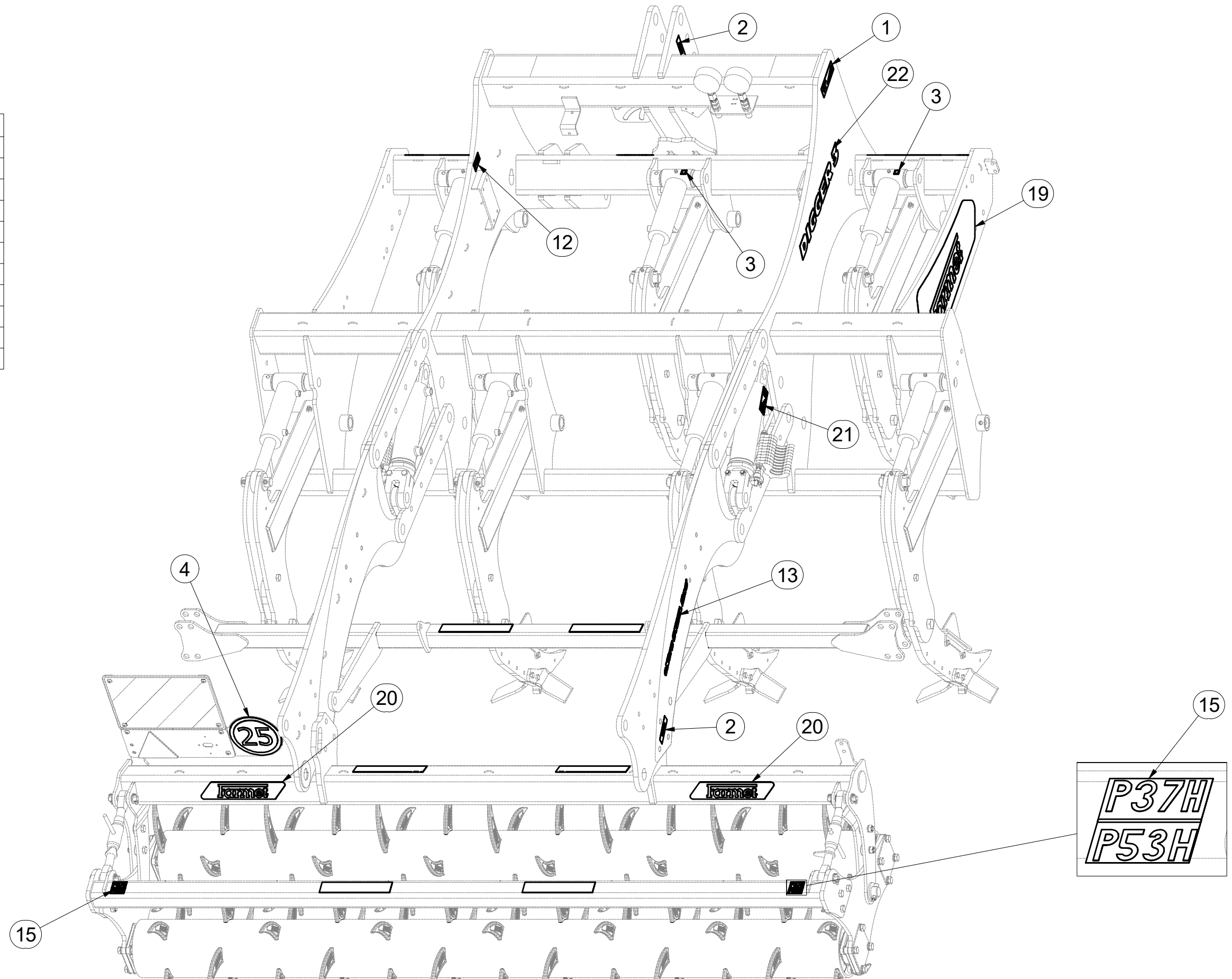

Ⓒ SVĚTELNÁ SADA

Ⓓ LEUCHTENSATZ

Ⓕ KIT LUMINEUX

Ⓖ LIGHTING SET

Ⓡ ОСВЕТИТЕЛЬНЫЙ КОМПЛЕКТ

Ⓟ ZESTAW OŚWIETLENIA



3008454

Pos.	Part Number	Pcs.
1	m16768	1
3	m05562	8
4	m05597	8
5	m15790	4
6	m10591	4
7	m06236	4
8	m16861	4
9	m05566	50

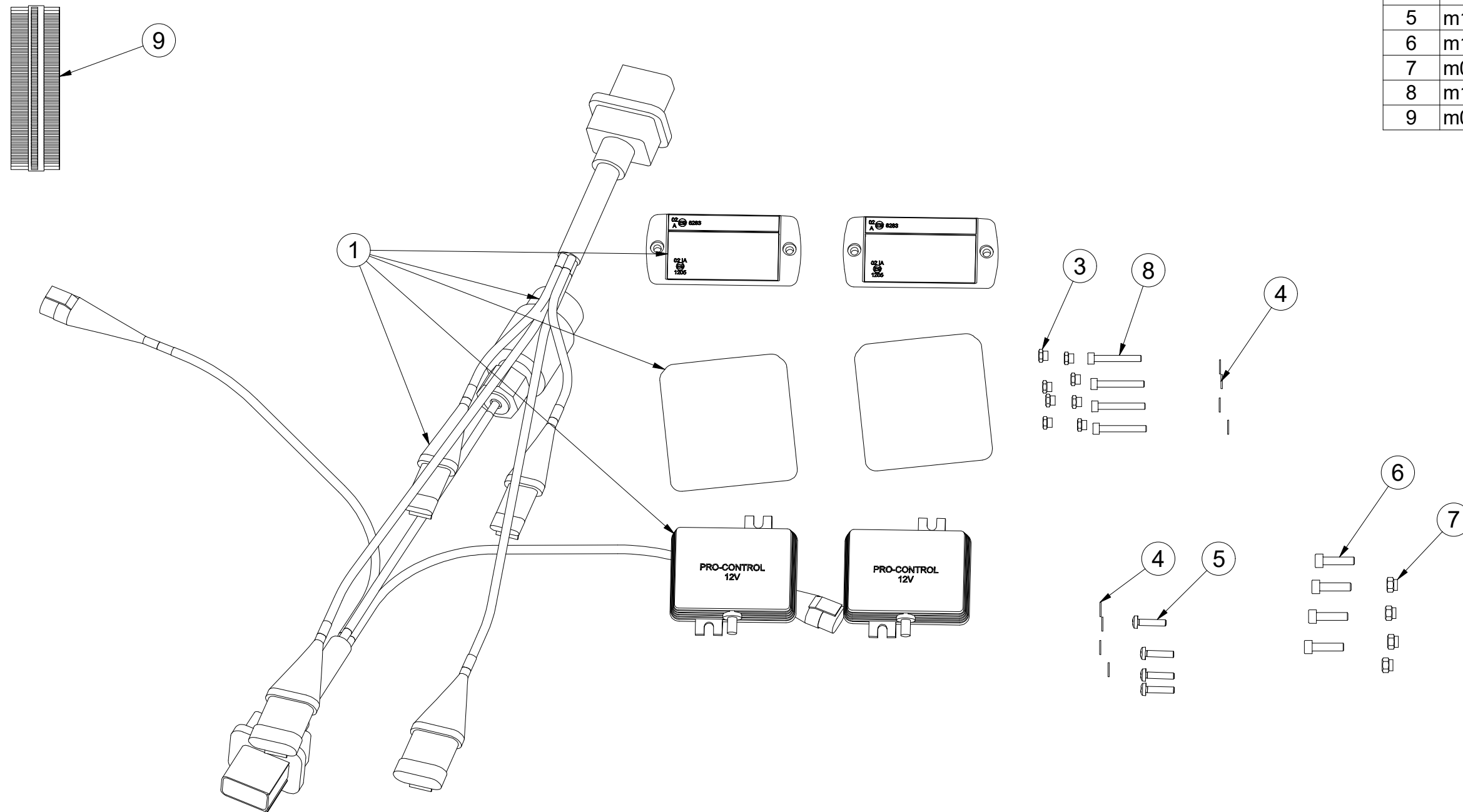

Ⓒ SVĚTELNÁ SADA

Ⓓ LEUCHTENSATZ

Ⓕ KIT LUMINEUX

m16768

Ⓒ LIGHTING SET

Ⓔ ОСВЕТИТЕЛЬНЫЙ КОМПЛЕКТ

Ⓗ ZESTAW OŚWIETLENIA

Farmet

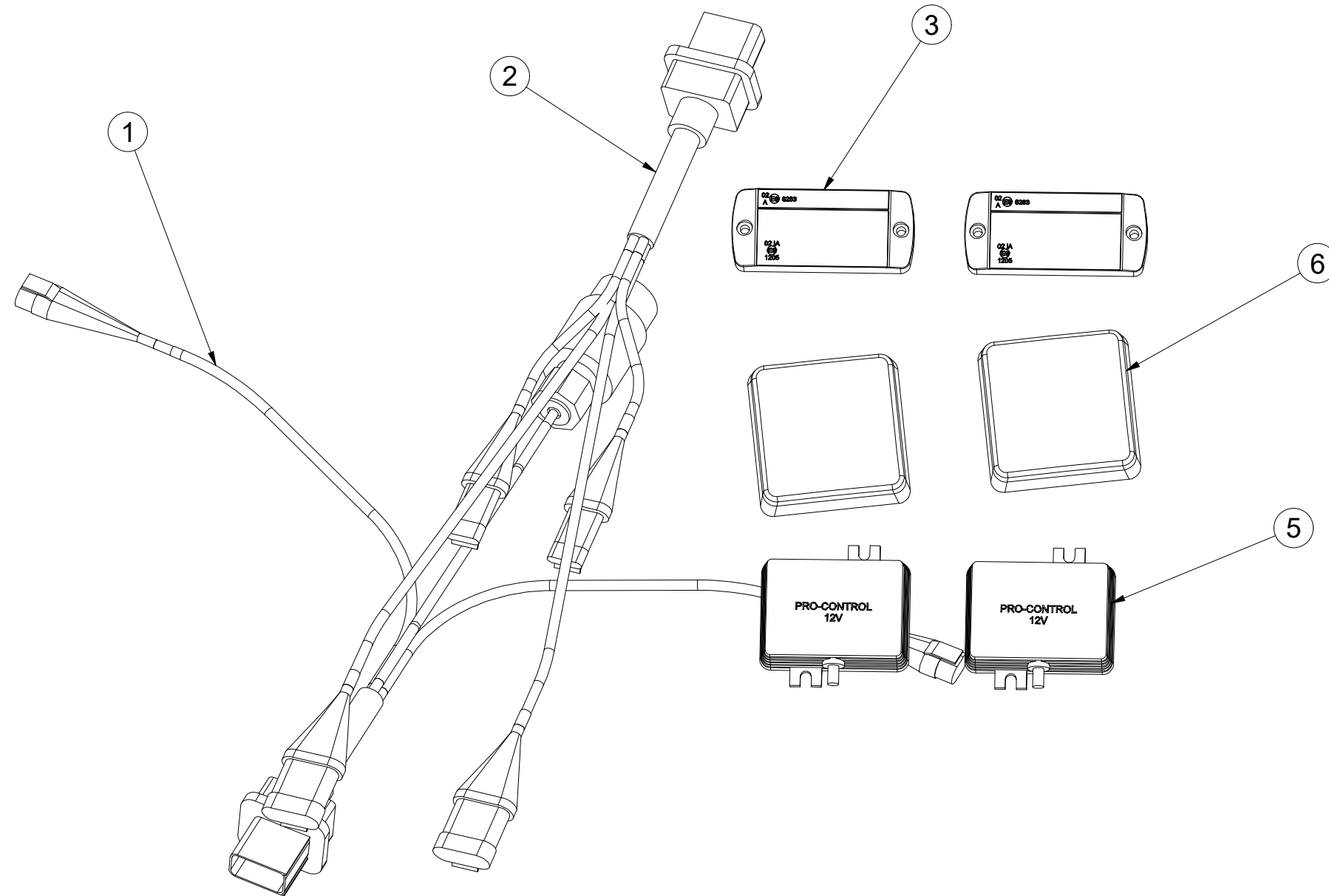

Pos.	Part Number	Pcs.
1	m14779	1
2	m14778	1
3	m14776	2
5	m14777	2
6	m19044	2

- Ⓒ UTAHOVACÍ MOMENTY ŠROUBŮ
 Ⓓ ANZUGMOMENTE VON SCHRAUBEN
 Ⓕ COUPLES DE SERRAGE DES VIS

- Ⓖ SCREW TIGHTENING TORQUE
 Ⓔ МОМЕНТЫ ЗАЖАТИЯ БОЛТОВ
 Ⓗ MOMENTY DOKRĘCANIA ŚRUB



P		5.8	8.8	10.9	12.9	Z	
D	R	Mu	Mu	Mu	Mu	DIN 7991	ISO 10642
mm	mm	Nm	Nm	Nm	Nm	Nm	Nm
M6	1	6	9	13	15	7,2	7,9
M8	1,25	14	22	32	38	17	19
M10	1,5	29	44	64	75	35	38
M12	1,75	49	76	111	130	58	65
M14	2	79	120	176	206	93	100
M16	2	123	188	276	323	144	158
M18	2,5	169	257	378	443	-	220
M20	2,5	239	365	536	628	-	310
M22	2,5	329	529	738	864	-	420
M24	3	413	629	924	1082	-	530
M27	3	613	934	1372	1606	-	-
M30	3,5	832	1267	1862	2179	-	-
M33	3,5	1130	1723	2530	2961	-	-
M36	4	1451	2210	3246	3799	-	-
M39	4	1885	2872	4217	4936	-	-
M42	4,5	2322	3538	5196	6080	-	-
M45	4,5	2909	4433	6511	7619	-	-
M48	5	3513	535	7862	9200	-	-
M52	5	4524	6895	10123	11849	-	-
M56	5,5	5636	8589	12614	14761	-	-

- Mu - Ⓒ UTAHOVACÍ MOMENT
 Ⓓ ANZUGMOMENTE
 Ⓕ COUPLE DE SERRAGE
 Ⓖ TIGHTENING TORQUE
 Ⓔ МОМЕНТ ЗАЖАТИЯ
 Ⓗ MOMENT DOKRĘCANIA
- D - Ⓒ JMENOVITÝ PRŮMĚR
 Ⓓ NENNDURCHMESSER
 Ⓕ DIAMETRE NOMINAL
 Ⓖ NOMINAL DIAMETER
 Ⓔ НОМИНАЛЬНЫЙ ДИАМЕТР
 Ⓗ ŚREDNICA NOMINALNA
- R - Ⓒ ROZTEČ ZÁVITU - STOUPÁNÍ
 Ⓓ GEWINDESTEIFUNG
 Ⓕ PAS DE FILET - PAS
 Ⓖ SCREW PITCH – LEAD
 Ⓔ ШАГ РЕЗЬБЫ
 Ⓗ ROZSTAW GWINTU - SKOKI
- P - Ⓒ PEVNOST
 Ⓓ FESTIGKEIT
 Ⓕ RÉSISTANCE
 Ⓖ STRENGTH
 Ⓔ ПРОЧНОСТЬ
 Ⓗ WYTRZYMA OŚĆ
- Z - Ⓒ ZÁPUSTNÉ ŠROUBY
 Ⓓ SENKKOPFSCHRAUBEN
 Ⓕ VIS A TETE FRAISEE
 Ⓖ COUNTERSUNK SCREWS
 Ⓔ БОЛТЫ С УТОПЛЕННОЙ ГОЛОВКОЙ
 Ⓗ ŚRUBY Z ŁBEM STOŻKOWYM PŁASKIM

- Ⓒ Hodnoty momentů jsou poníženy o -10% oproti tabulkovým hodnotám. Šroubové spoje utahujte dle vyznačeného utahovacího momentu v dokumentaci. Pokud není utahovací moment v dokumentaci vyznačen, utahujte dle obecné tabulky. Pokud je v dokumentaci definován spoj šroubu a matice o různých pevnostech, vždy utahujte na moment komponenty nižší.
- Ⓓ Die Werte der Anzugsmomente sind um 10 % gegenüber den Tabellenwerten verringert. Ziehen Sie die Schraubverbindungen gemäß dem in der Dokumentation festgeschriebenen Anzugsmoment an. Sofern das Anzugsmoment nicht in der Dokumentation aufgeführt ist, ziehen Sie sie gemäß der allgemeinen Tabelle an. Wenn in der Dokumentation eine Verbindung von Schraube und Mutter mit verschiedene Festigkeiten definiert ist, wird immer mit dem Moment des Bauteils mit der geringeren Festigkeit angezogen.
- Ⓕ Les valeurs des couples de serrage sont baissées de 10% par rapport aux valeurs de tableau. Serrez les raccords à vis selon le couple de serrage indiqué dans les documents. Si le couple de serrage n'est pas indiqué dans les documents, serrez selon le tableau général. Si les documents définissent un assemblage par boulon de diverses résistances, serrez toujours au moment de la composante avec résistance inférieure.
- Ⓖ The torque values are reduced by 10% compared to the table values. Tighten the screw joints according to the tightening torque stated in the documentation. If the tightening torque is not stated in the documentation, tighten according to the general table. If there is a joint with a screw and a nut at different strengths in the documentation, always tighten to the torque of the component with lower strength.
- Ⓔ Значения моментов затяжки уменьшены на 10% по сравнению с данными в таблице. Резьбовые соединения зажимайте с установленным в документации моментом зажатия. Если в документации не указан момент зажатия, то зажимайте по действующей в общем таблице. Если в документации установлено соединение из болта и гайки различной прочности, всегда зажимайте с моментом для компонента с меньшей прочностью.
- Ⓗ Wartości momentów dokręcania są obniżone o 10% w stosunku do wartości z tabeli. Połączenia śrubowe należy dokręcać zgodnie z momentem obrotowym w dokumentacji. Jeśli w dokumentacji nie ma podanego momentu obrotowego, należy dokręcać zgodnie z ogólną tabelą. Jeśli w dokumentacji zdefiniowane jest połączenie ze śrubą nakrętką różnych wytrzymałościach, zawsze należy dokręcać zachowując moment dokręcania komponentu z niższą wytrzymałością.

- Ⓒ UTAHOVACÍ MOMENTY ŠROUBŮ
 Ⓓ ANZUGMOMENTE VON SCHRAUBEN
 Ⓕ COUPLES DE SERRAGE DES VIS

- Ⓖ SCREW TIGHTENING TORQUE
 Ⓡ MOMENTY ZAJATIA BOLTOB
 Ⓟ MOMENTY DOKRĘCANIA ŚRUB



- Ⓒ **OBECNÝ PŘEDPIS UTAHOVÁNÍ ZAJIŠTĚNÍ ČEPOVÝCH SPOJŮ:**
 Ⓓ **ALLGEMEINE VORSCHRIFT FÜR DAS ANZIEHEN VON BOLZENVERBINDUNGEN:**
 Ⓕ **CONSIGNE GENERALE POUR LE SERRAGE DES ARTICULATIONS CYLINDRIQUES:**
 Ⓖ **GENERAL INSTRUCTION FOR TIGHTENING THE SECURING OF PIN JOINTS:**
 Ⓡ **ОБЩЕЕ ОПИСАНИЕ ЗАЖАТИЯ ПРЕДОХРАНЕНИЯ СОЕДИНЕНИЙ ПАЛЬЦАМИ:**
 Ⓟ **OGÓLNE ZASADY DOKRĘCANIA ZABEZPIECZENIA POŁĄCZEŃ CZOPEM:**



X

M8, M10, M12

M14

M

09-15Nm

15-25Nm

- X - Ⓒ ROZMĚR ŠROUBU
 Ⓓ SCHRAUBENGRÖSSE
 Ⓕ DIMENSIONS DE LA VIS

- Ⓖ BOLT DIMENSION
 Ⓡ РАЗМЕР БОЛТА
 Ⓟ ROZMIAR ŚRUBY

- M - Ⓒ ORIENTAČNÍ MOMENT
 Ⓓ ANZUGSMOMENT
 Ⓕ COUPLE D'ORIENTATION

- Ⓖ ORIENTATION TORQUE
 Ⓡ ОРИЕНТАЦИОННЫЙ МОМЕНТ
 Ⓟ ORIENTACYJNY MOMENT

- Ⓒ Tyto spoje není nutné ověřovat kontrolou momentovým klíčem = stačí vizuálně kontrolovat sešroubování.
 Ⓓ Diese Verbindungen müssen nicht mit einem Drehmomentschlüssel überprüft werden = es genügt, die Verschraubung visuell zu kontrollieren.
 Ⓕ Il n'est pas nécessaire de contrôler le serrage à l'aide d'une clé dynamométrique = un contrôle visuel de l'assemblage suffit.
 Ⓖ These joints do not have to be verified by checking with a torque wrench = visual inspection of bolting is sufficient.
 Ⓡ Эти соединения не нужно контролировать динамометрическим ключом = достаточно визуально проверять прикручивание.
 Ⓟ Nie trzeba sprawdzać tych połączeń kluczem dynamometrycznym = wystarczy wizualnie skontrolować dokręcenie.