

The effective technology

Farmet[®]

ⒸZ KATALOG NÁHRADNÍCH DÍLŮ ⒸB CATALOGUE OF SPARE PARTS ⒸD ERSATZTEILLISTE
ⒸRU КАТАЛОГ ЗАПАСНЫХ ЧАСТЕЙ ⒸF CATALOGUE DES PIÈCES DE RECHANGE ⒸPL KATALOG CZĘŚCI ZAMIENNYCH

КОМПАКТОМАТ K800PS

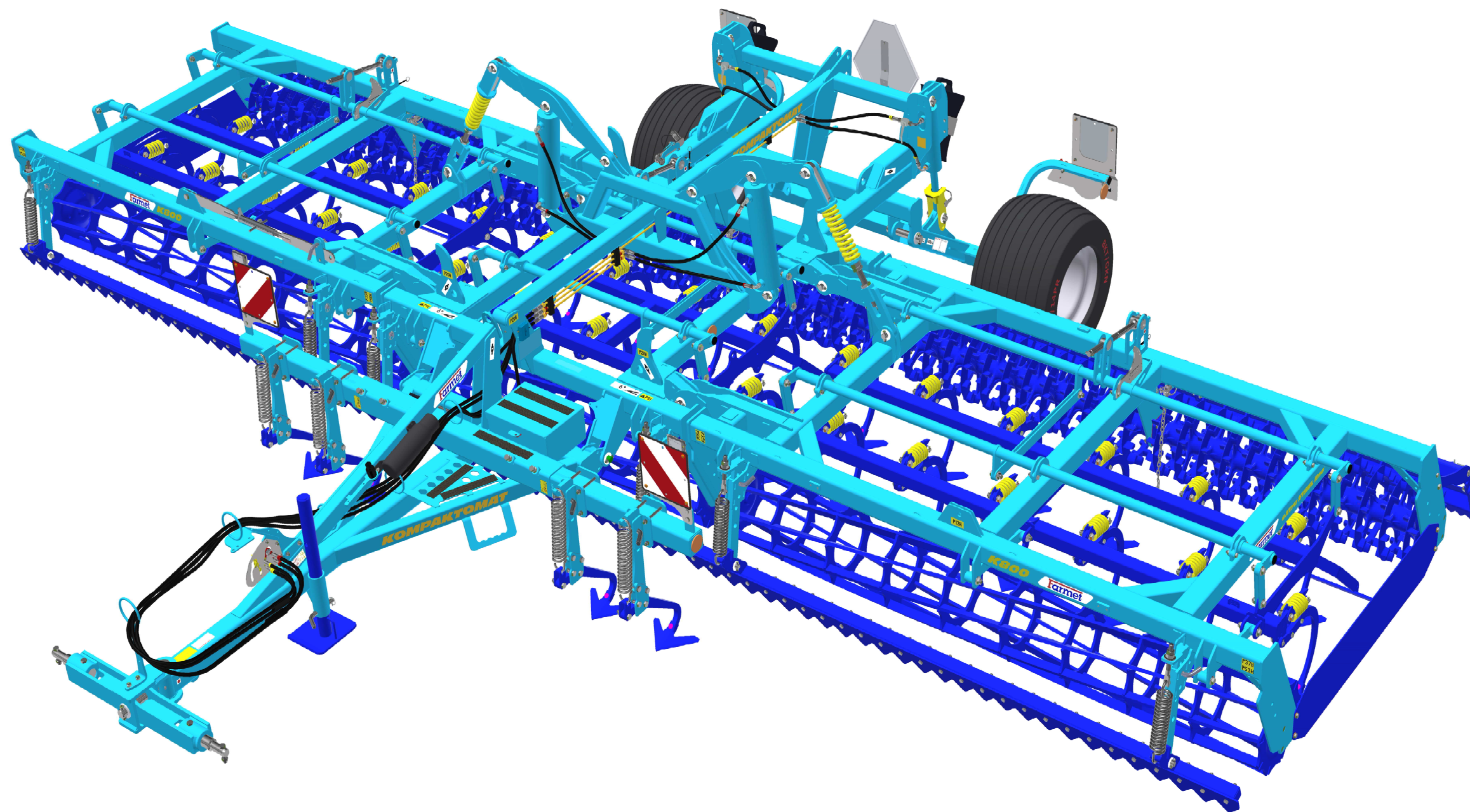

ⒸZ Platnost pro vrcholové | výrobní číslo stroje ⒸB Validity for the top | serial number of the machine
ⒸD Gültigkeit für die Haupt- | Herstellungsnummer der Maschine ⒸRU Действительно для главного | заводского номера машины
ⒸF Validité du numéro de référence | de série de la machine ⒸPL Obowiązuje dla numeru głównego | seryjnego maszyny

9303981 | 2022/1135

Farmet a. s.
Jiřinková 276
552 03 Česká Skalice, CZ

telefon: +420 491 450 111
fax: +420 491 450 136
GSM: +420 774 715 738

IČ: 46504931
DIČ: CZ46504931

web: www.farmet.cz
e-mail: farmet@farmet.cz

ⒸZ NAVIGACE STROJE

Ⓓ NAVIGATION DER MASCHINE

Ⓕ NAVIGATION DE LA MACHINE

ⒸB NAVIGATION OF THE MACHINE

ⒸU НАВИГАЦИЯ МАШИНЫ

ⒸL NAWIGACJA MASZYNY

Farmet

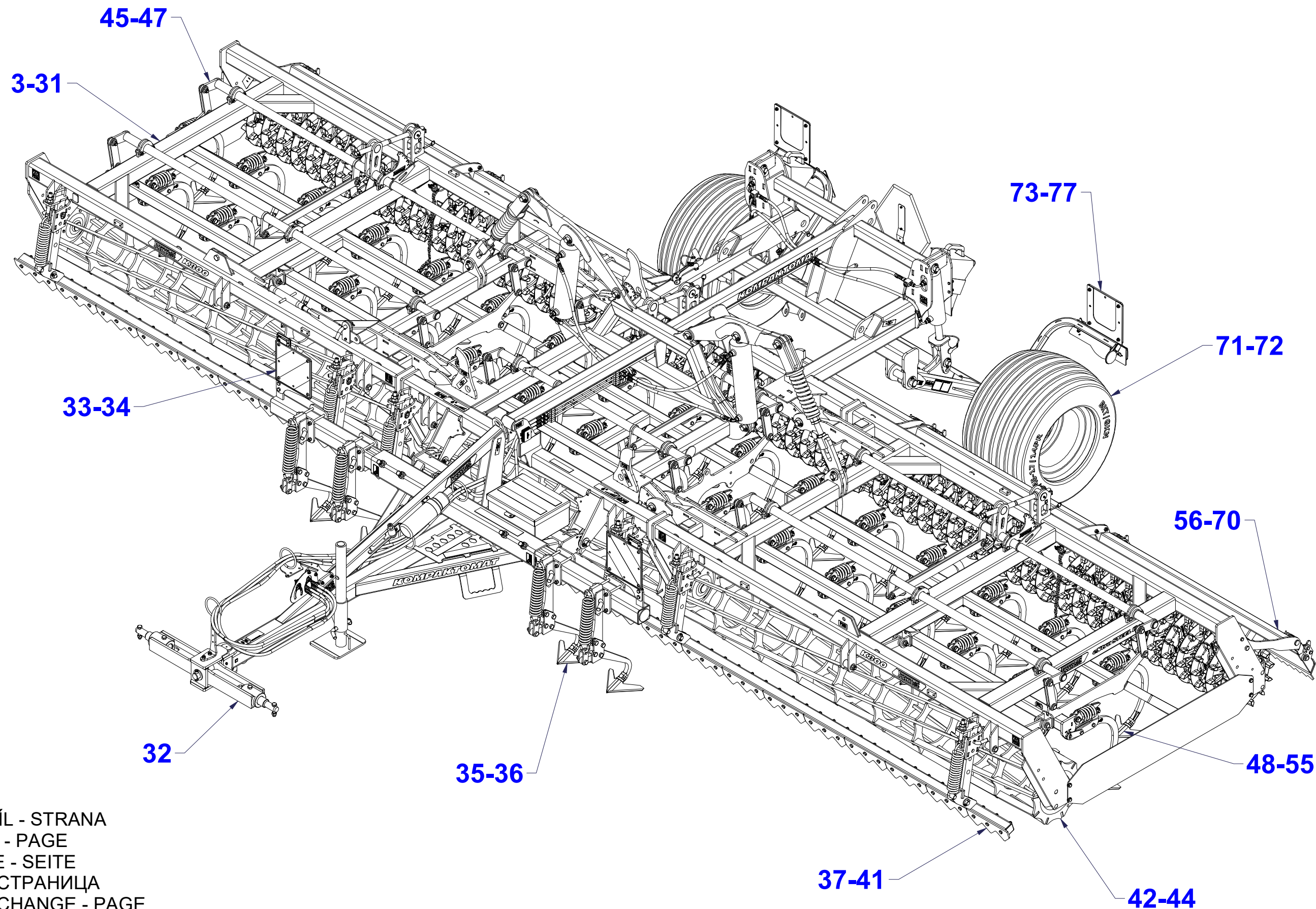

ⒸZ NÁHRADNÍ DÍL - STRANA

ⒸB SPARE PART - PAGE

Ⓓ ERSATZTEILE - SEITE

ⒸU ЗАПЧАСТЬ - СТРАНИЦА

Ⓕ PIÈCE DE RECHANGE - PAGE

ⒸL CZĘŚCI ZAMIENNE - STRONA

Ⓒ POLOTOVAR STROJE

Ⓓ MASCHINEN-HALBFABRIKAT

Ⓕ MACHINE - SEMI-PRODUIT

Ⓖ SEMIFINISHED MACHINE

Ⓡ ПОЛУФАБРИКАТ МАШИНЫ

Ⓟ PÓLFABRYKAT MASZYN



VZ00019240

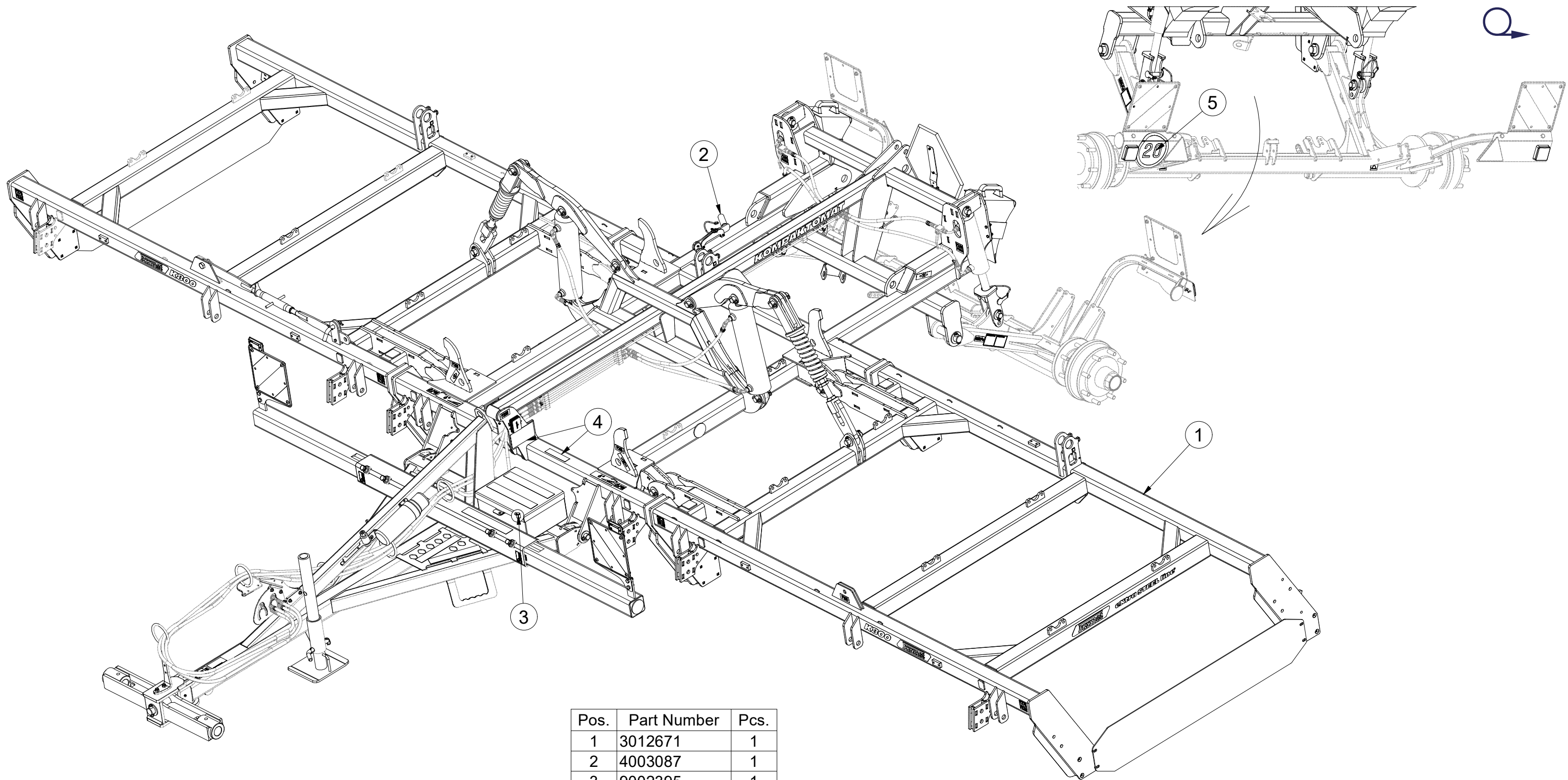

Pos.	Part Number	Pcs.
1	3012671	1
2	4003087	1
3	9002395	1
4	4025948	1
5	4026236	1

CZ NASAZOVACÍ KLIKA
 D EINSTELLKURBEL
 F MANIVELLE AMOVIBILE

GB PRESS-ON HANDLE
 RU НАСАЖИВАЕМАЯ РУКОЯТКА
 PL KLAMKA MOCOWANA



4003087

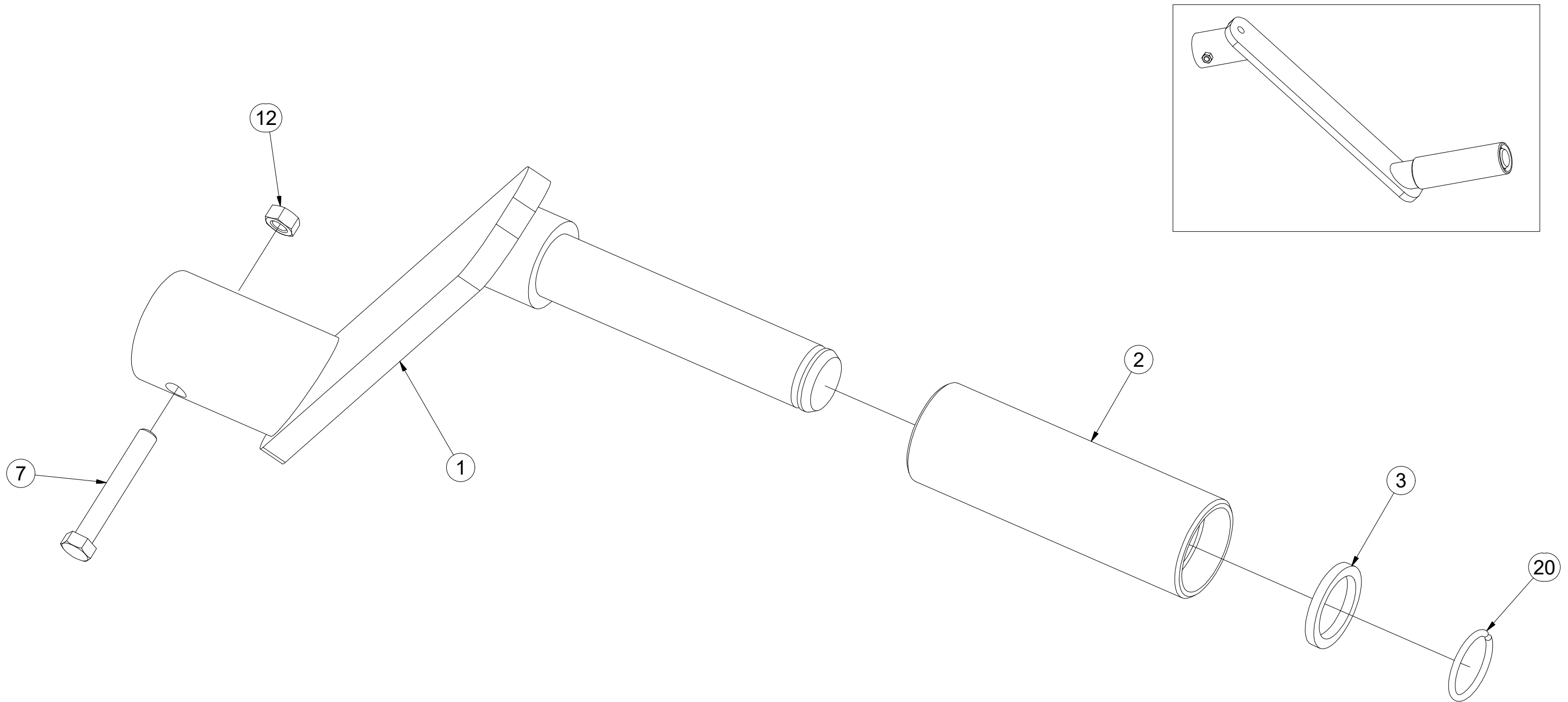

Pos.	Part Number	Pcs.
1	4003092	1
2	4001533	1
3	4004828	1
7	m04641	1
12	m01295	1
20	m06561	1

Ⓒ POLOTOVAR STROJE

Ⓓ MASCHINEN-HALBFABRIKAT

Ⓕ MACHINE - SEMI-PRODUIT

Ⓖ SEMIFINISHED MACHINE

Ⓡ ПОЛУФАБРИКАТ МАШИНЫ

Ⓟ PÓŁFABRYKAT MASZYN



3012671

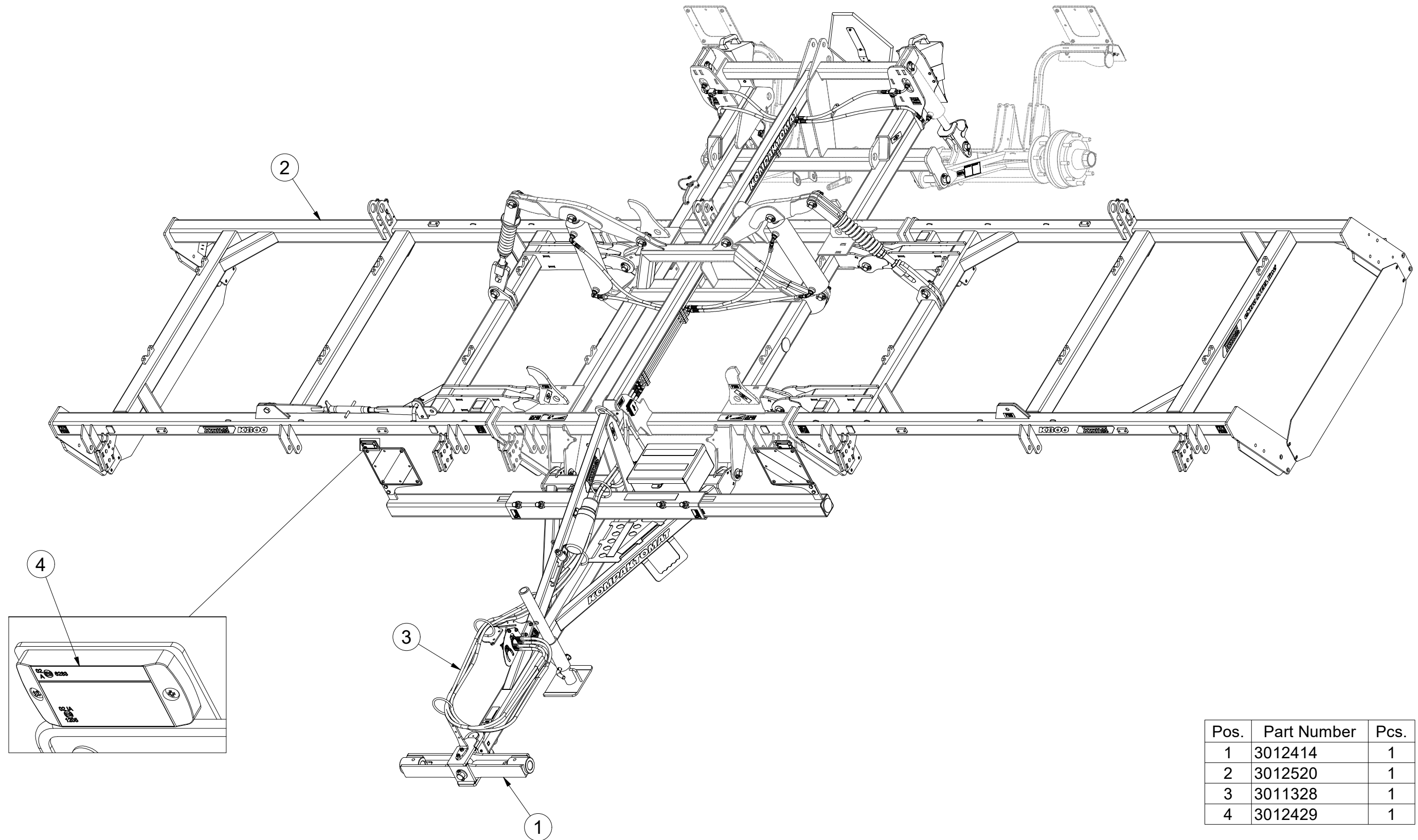

Pos.	Part Number	Pcs.
1	3012414	1
2	3012520	1
3	3011328	1
4	3012429	1

☉ POLOTOVAR STROJE

☉ MASCHINEN-HALBFABRIKAT

☉ MACHINE - SEMI-PRODUIT

☉ SEMIFINISHED MACHINE

☉ ПОЛУФАБРИКАТ МАШИНЫ

☉ PÓLFABRYKAT MASZYNY



3012671

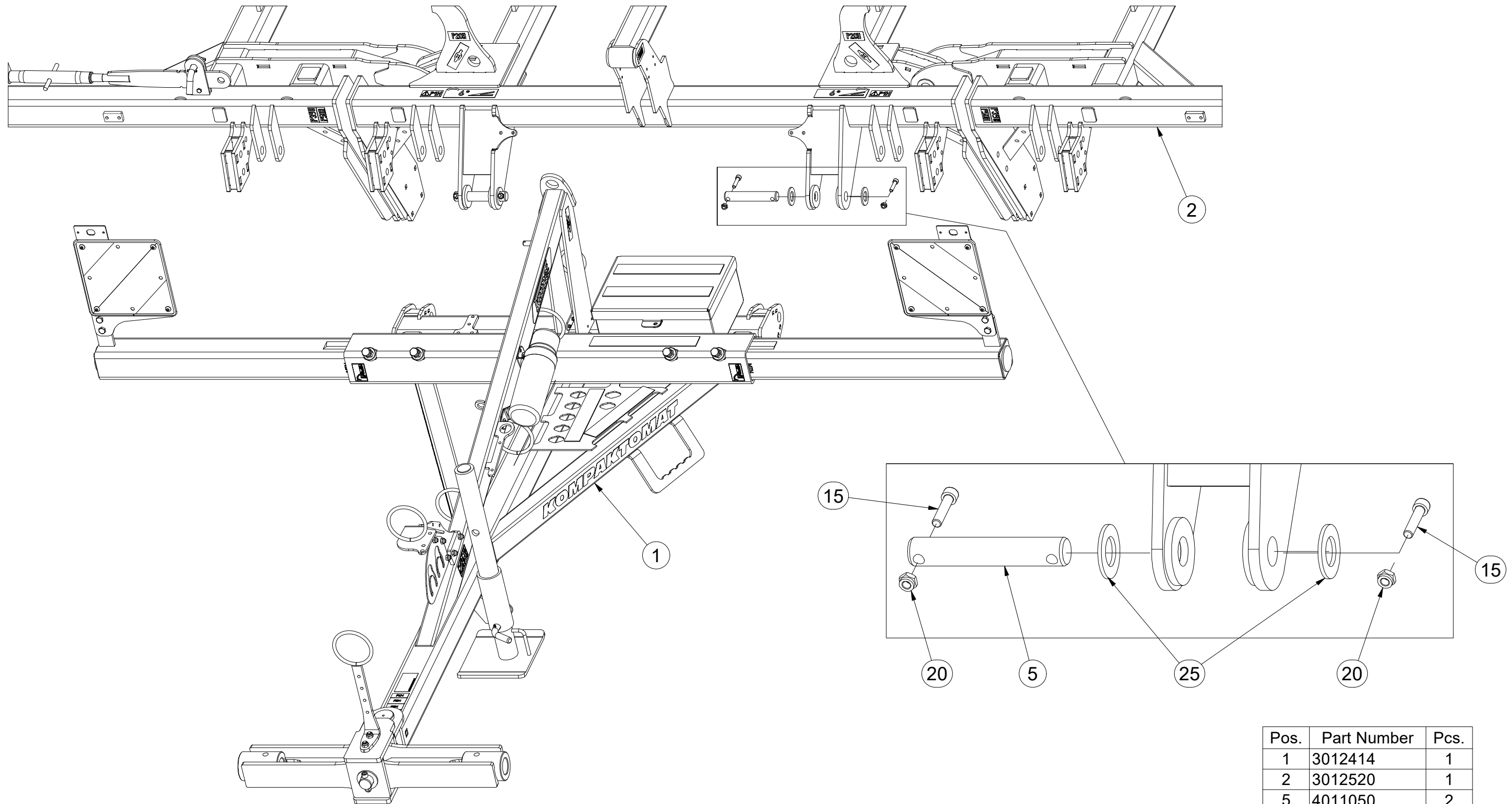

Pos.	Part Number	Pcs.
1	3012414	1
2	3012520	1
5	4011050	2
15	m14143	4
20	m03775	4
25	m14029	4

Ⓒ POLOTOVAR STROJE

Ⓓ MASCHINEN-HALBFABRIKAT

Ⓕ MACHINE - SEMI-PRODUIT

Ⓖ SEMIFINISHED MACHINE

Ⓡ ПОЛУФАБРИКАТ МАШИНЫ

Ⓟ PÓŁFABRYKAT MASZYNY



VZ00027444

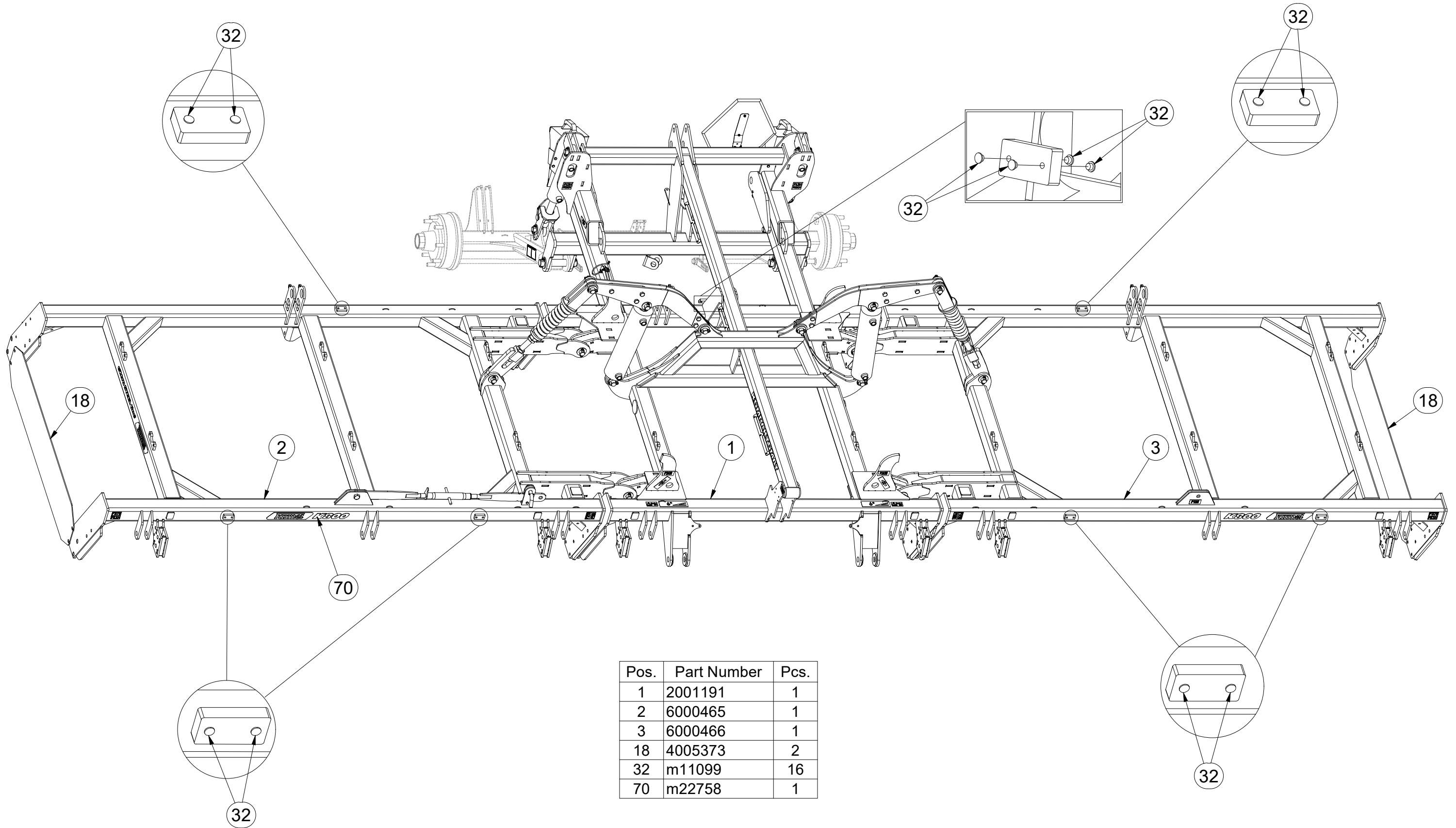

Pos.	Part Number	Pcs.
1	2001191	1
2	6000465	1
3	6000466	1
18	4005373	2
32	m11099	16
70	m22758	1

Ⓒ POLOTOVAR STROJE

Ⓓ MASCHINEN-HALBFABRIKAT

Ⓕ MACHINE - SEMI-PRODUIT

Ⓖ SEMIFINISHED MACHINE

Ⓡ ПОЛУФАБРИКАТ МАШИНЫ

Ⓟ PÓŁFABRYKAT MASZYN



VZ00027444

Pos.	Part Number	Pcs.	Pos.	Part Number	Pcs.
1	2001191	1	30	m02579	2
2	6000465	1	41	m01096	1
6	4005363	2	43	m14143	36
7	4021664	2	45	m04241	1
10	4003966	1	51	m04503	9
11	4007641	4	52	m03775	36
12	4007584	2	54	m05648	1
13	4014569	2	55	m04043	2
24	4012011	1	61	m14029	36
25	m10454	2			

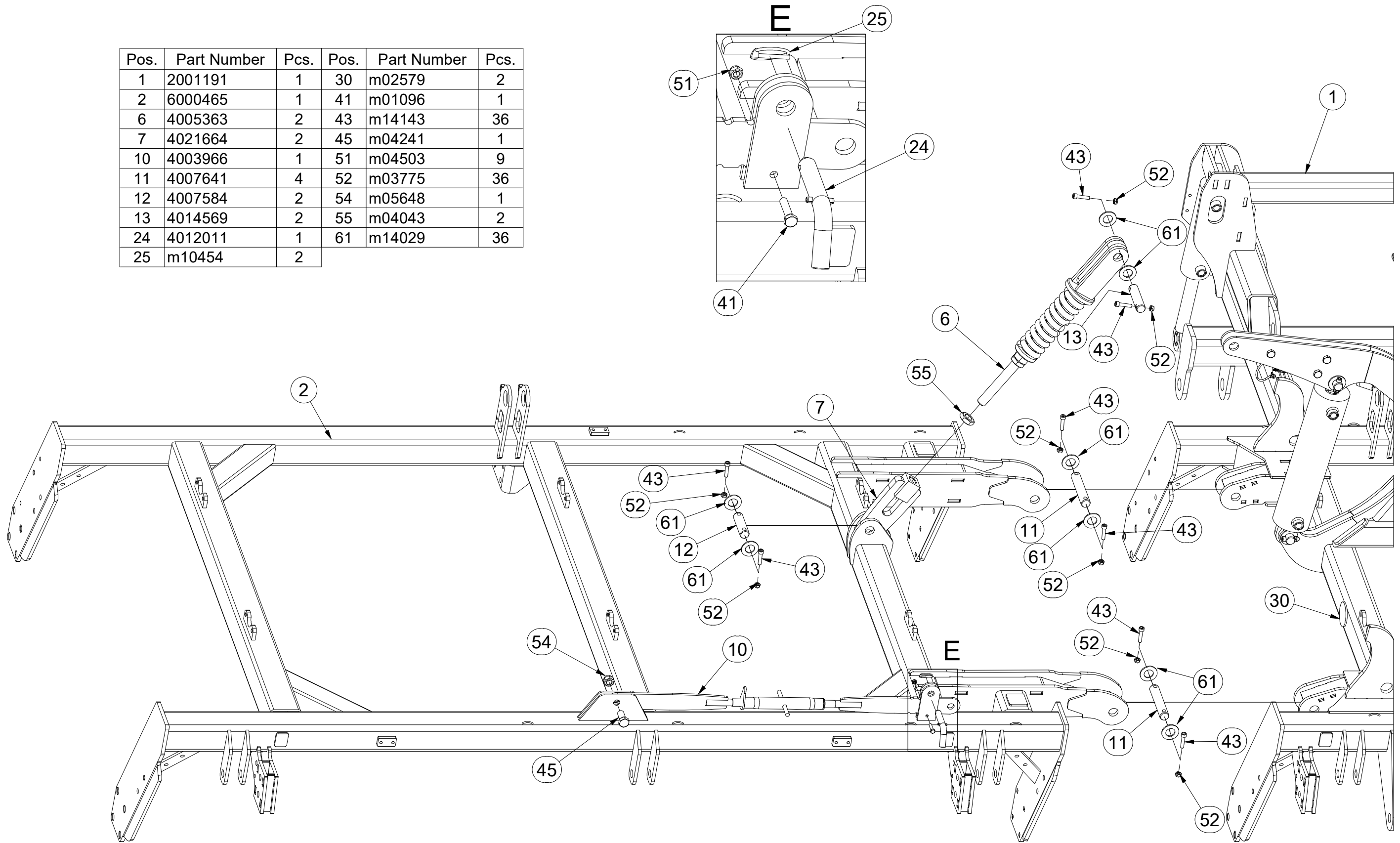

☉ POLOTOVAR STROJE

☉ MASCHINEN-HALBFABRIKAT

☉ MACHINE - SEMI-PRODUIT

☉ SEMIFINISHED MACHINE

☉ ПОЛУФАБРИКАТ МАШИНЫ

☉ PÓLFABRYKAT MASZYNY



VZ00027444

Pos.	Part Number	Pcs.
1	2001191	1
3	6000466	1
6	4005363	2
7	4021664	2
11	4007641	4
12	4007584	2
13	4014569	2
30	m02579	2
43	m14143	36
52	m03775	36
55	m04043	2
61	m14029	36

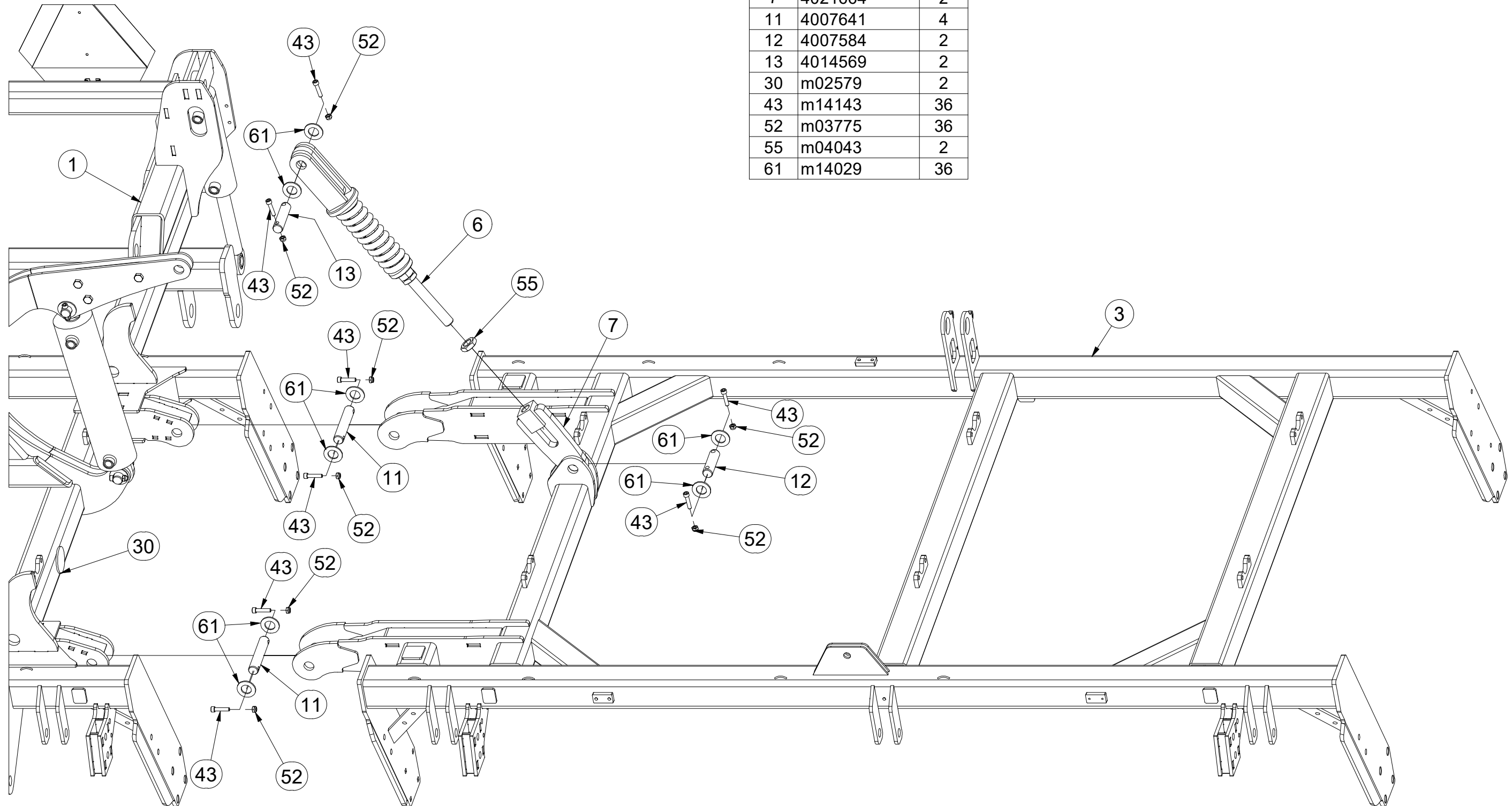

Ⓒ POLOTOVAR STROJE

Ⓓ MASCHINEN-HALBFABRIKAT

Ⓕ MACHINE - SEMI-PRODUIT

Ⓖ SEMIFINISHED MACHINE

Ⓡ ПОЛУФАБРИКАТ МАШИНЫ

Ⓟ PÓŁFABRYKAT MASZYN



VZ00027444

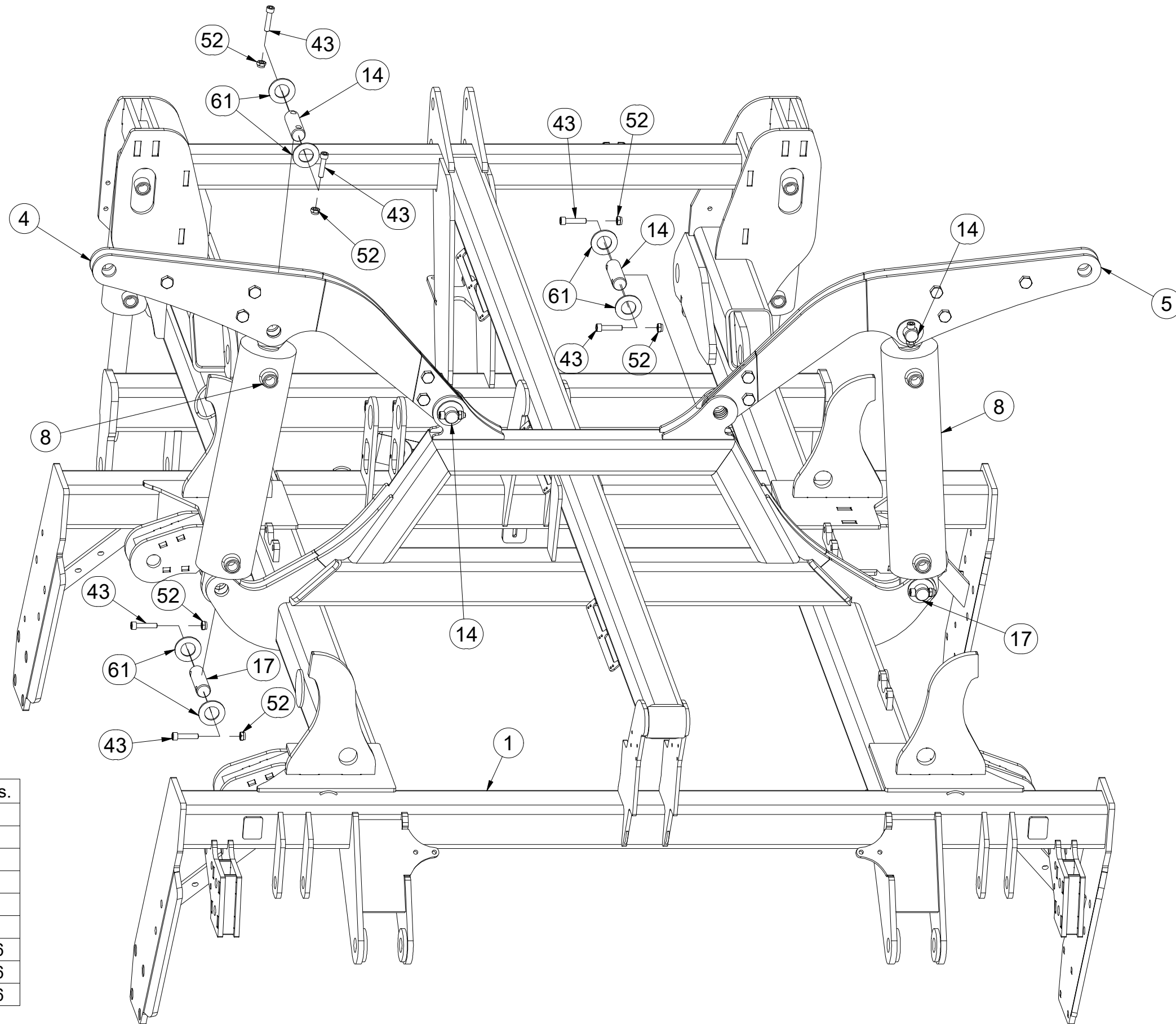

Pos.	Part Number	Pcs.
1	2001191	1
4	VZ00004775	1
5	VZ00004774	1
8	VZ00013004	2
14	4007640	4
17	4008234	4
43	m14143	36
52	m03775	36
61	m14029	36

Ⓒ POLOTOVAR STROJE

Ⓓ MASCHINEN-HALBFABRIKAT

Ⓕ MACHINE - SEMI-PRODUIT

Ⓖ SEMIFINISHED MACHINE

Ⓡ ПОЛУФАБРИКАТ МАШИНЫ

Ⓟ PÓLFABRYKAT MASZYNY



VZ00027444

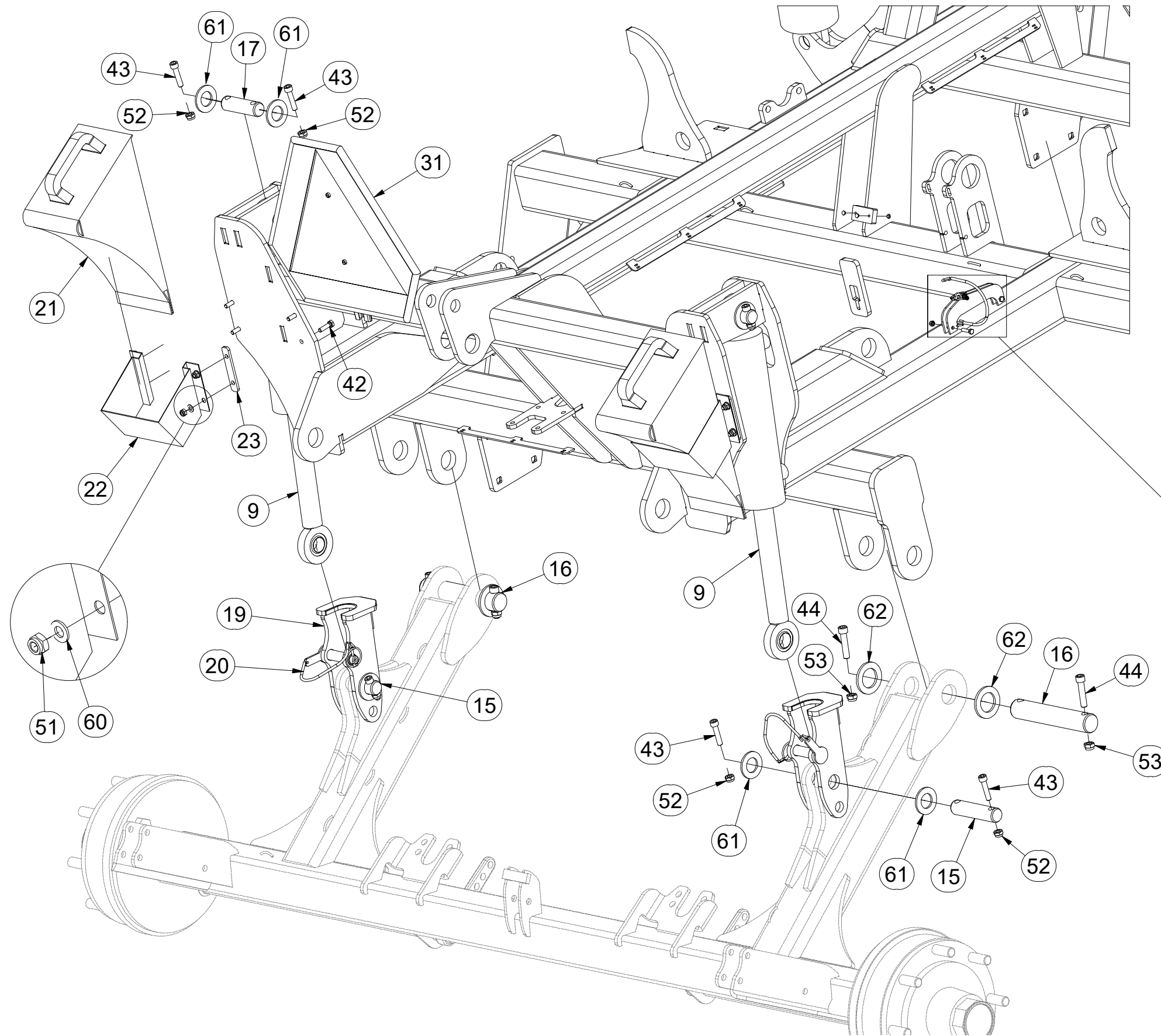

Pos.	Part Number	Pcs.
9	VZ00004549	2
15	4011761	2
16	4010875	2
17	4008234	4
19	4022352	2
20	4023535	2
25	m10454	2
21	m16186	2
22	m12572	2
23	4012712	4
31	m05371	1
33	m12467	1
40	m01075	2
42	m04791	8
43	m14143	36
44	m14008	4
50	m05560	2
51	m04503	9
52	m03775	36
53	m04301	4
60	m01203	8
61	m14029	36
62	4013139	4

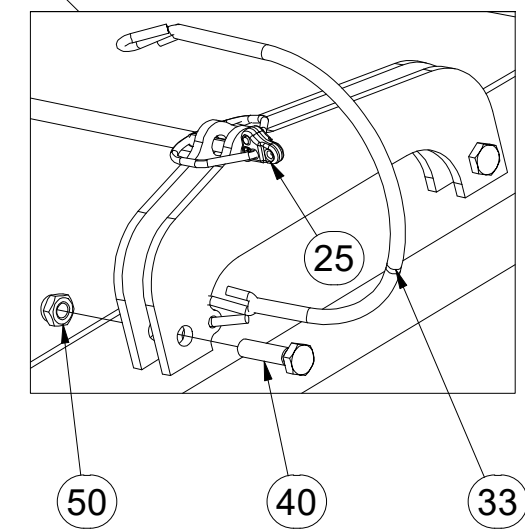

- Ⓒ RÁM
- Ⓓ RAHMEN
- Ⓕ CHASSIS

- Ⓖ FRAME
- Ⓡ PAMA
- Ⓟ RAMA



VZ00004774

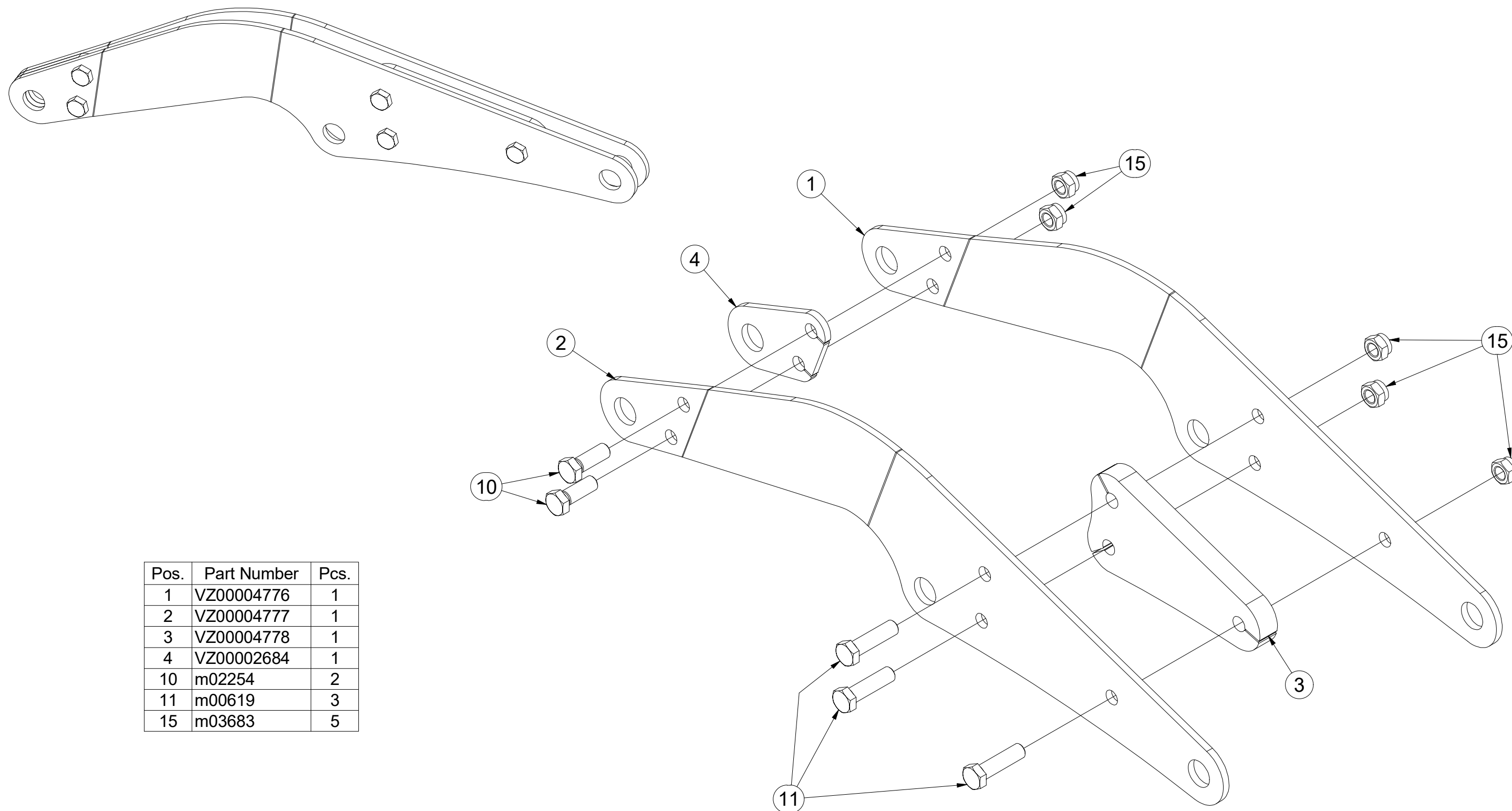

Pos.	Part Number	Pcs.
1	VZ00004776	1
2	VZ00004777	1
3	VZ00004778	1
4	VZ00002684	1
10	m02254	2
11	m00619	3
15	m03683	5

Ⓒ RÁM

Ⓓ RAHMEN

Ⓕ CHASSIS

Ⓖ FRAME

Ⓡ PAMA

Ⓢ RAMA



VZ00004775

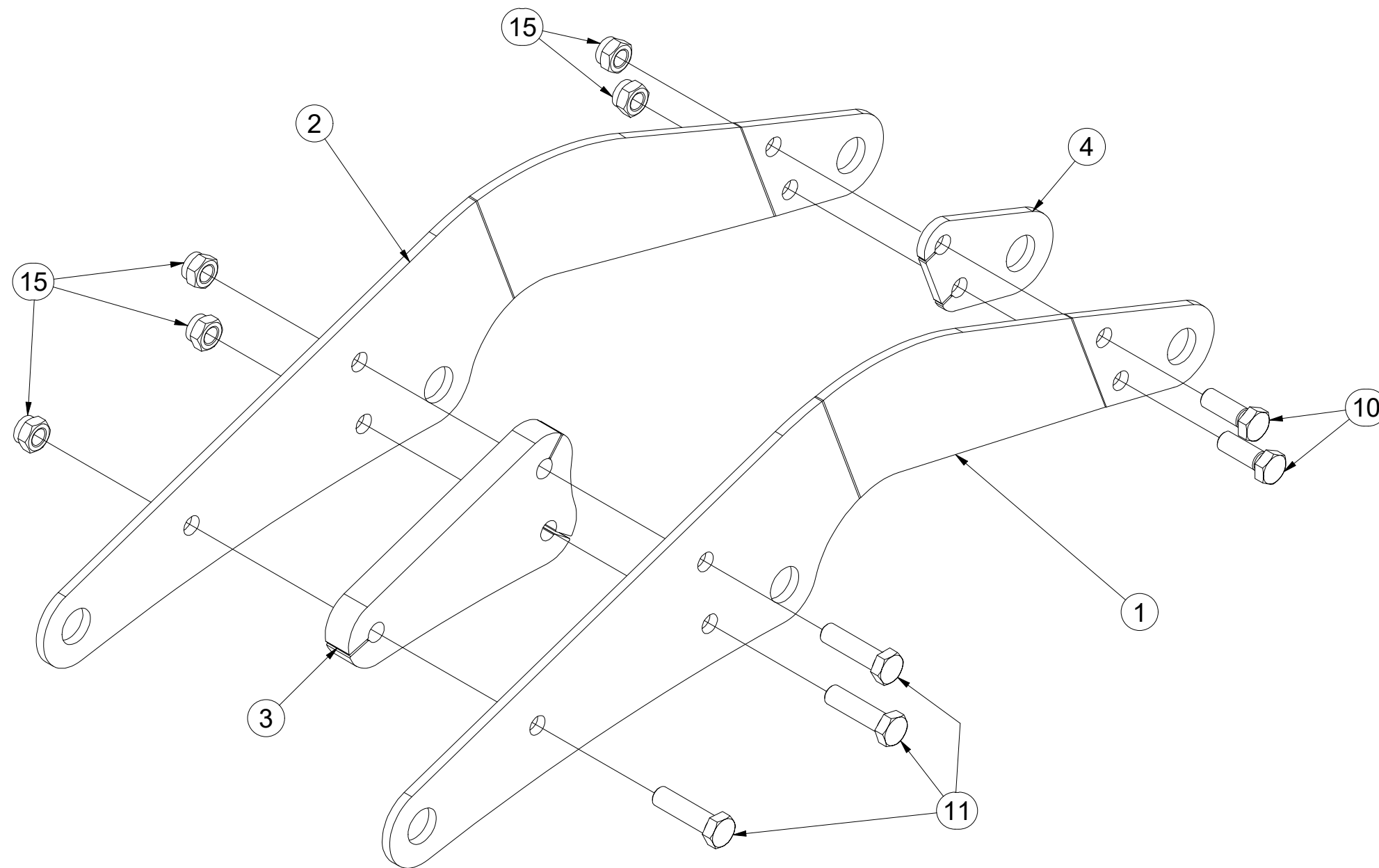
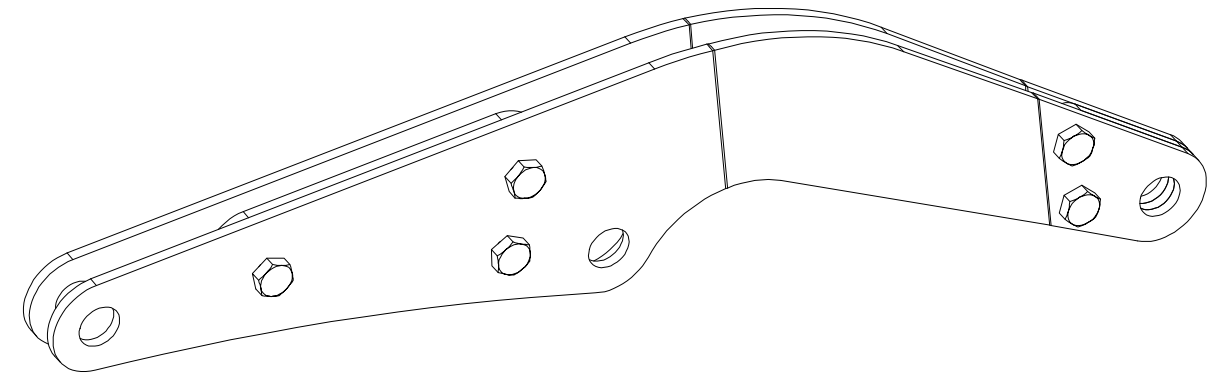

Pos.	Part Number	Pcs.
1	VZ00004776	1
2	VZ00004777	1
3	VZ00004778	1
4	VZ00002684	1
10	m02254	2
11	m00619	3
15	m03683	5

Ⓒ SAMOLEPKY STROJE

Ⓓ AUFKLEBER MASCHINEN

Ⓕ VOITURE MACHINES

Ⓖ STICKERS MACHINES

Ⓡ СТИКЕРЫ МАШИНЫ

Ⓟ NAKLEJKI MASZYNY



m22758

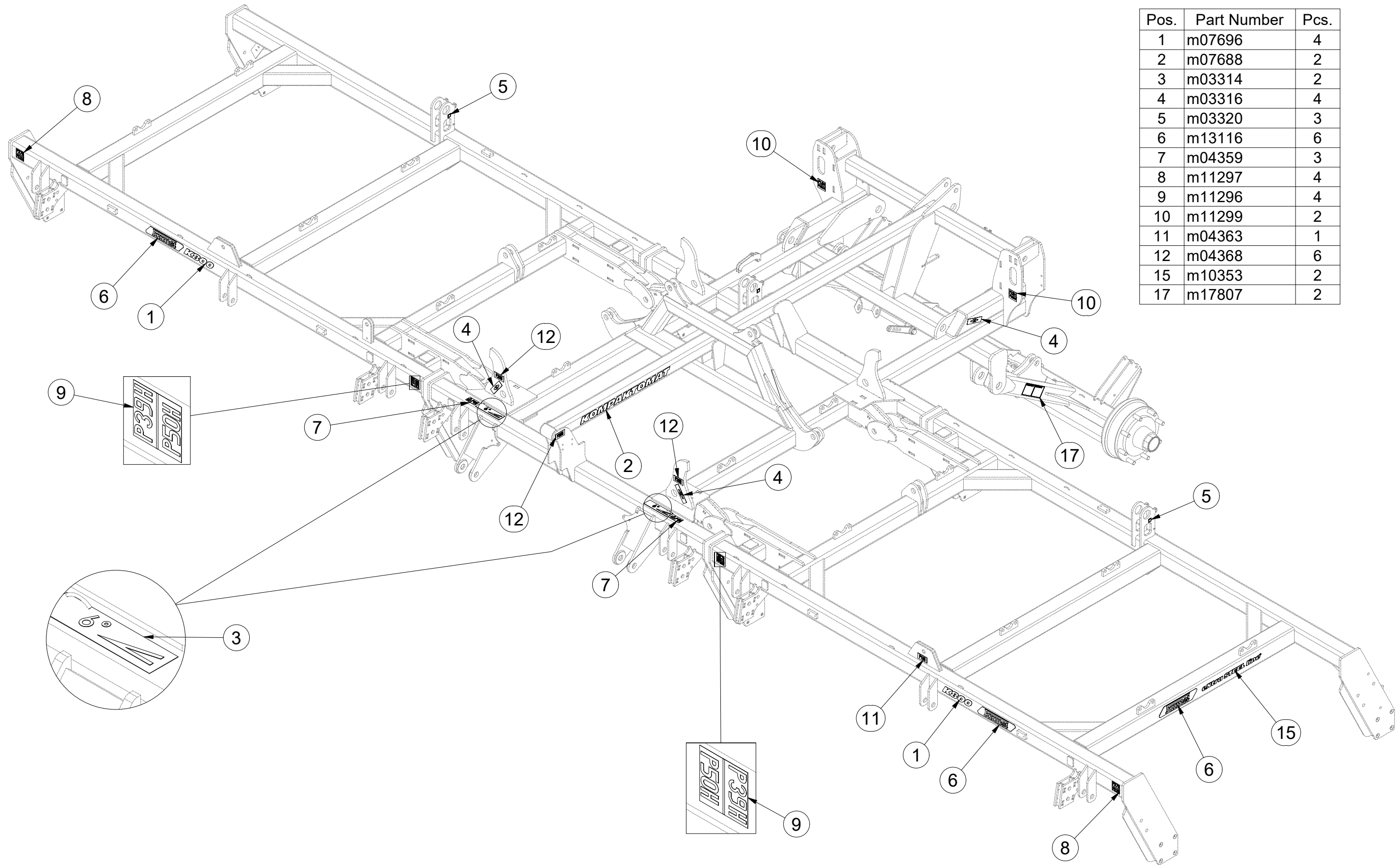

Pos.	Part Number	Pcs.
1	m07696	4
2	m07688	2
3	m03314	2
4	m03316	4
5	m03320	3
6	m13116	6
7	m04359	3
8	m11297	4
9	m11296	4
10	m11299	2
11	m04363	1
12	m04368	6
15	m10353	2
17	m17807	2

Ⓒ SAMOLEPKY STROJE

Ⓓ AUFKLEBER MASCHINEN

Ⓕ VOITURE MACHINES

Ⓖ STICKERS MACHINES

Ⓡ СТИКЕРЫ МАШИНЫ

Ⓟ NAKLEJKI MASZYNY



m22758

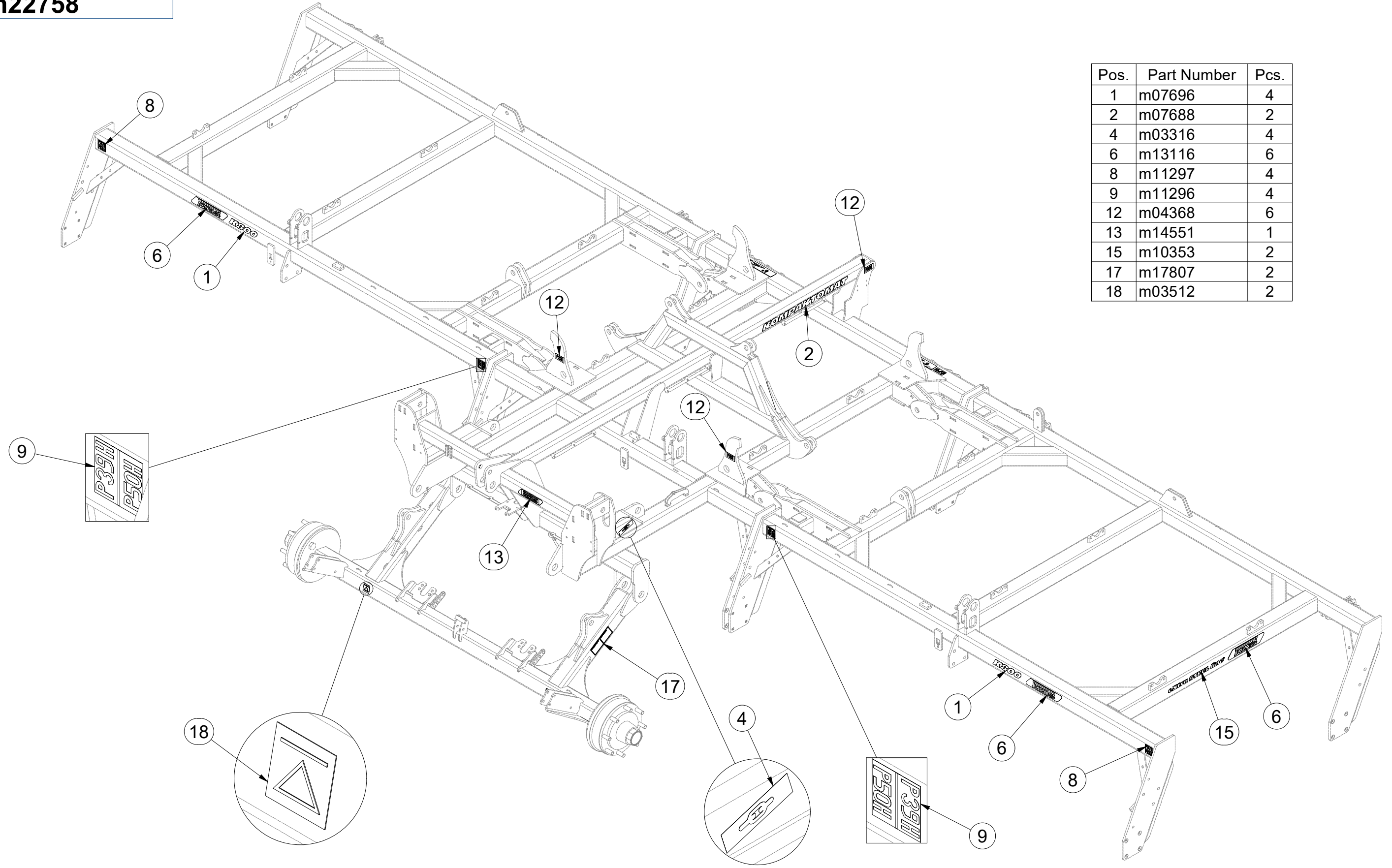

Pos.	Part Number	Pcs.
1	m07696	4
2	m07688	2
4	m03316	4
6	m13116	6
8	m11297	4
9	m11296	4
12	m04368	6
13	m14551	1
15	m10353	2
17	m17807	2
18	m03512	2

Ⓒ SADA DORAZŮ
Ⓓ ANSCHLAGSATZ
Ⓕ KIT DE BUTÉES

Ⓖ SET OF BAR STOPS
Ⓔ КОМПЛЕКТ УПОРОВ
Ⓗ ZESTAW DOCISKÓW



4022352

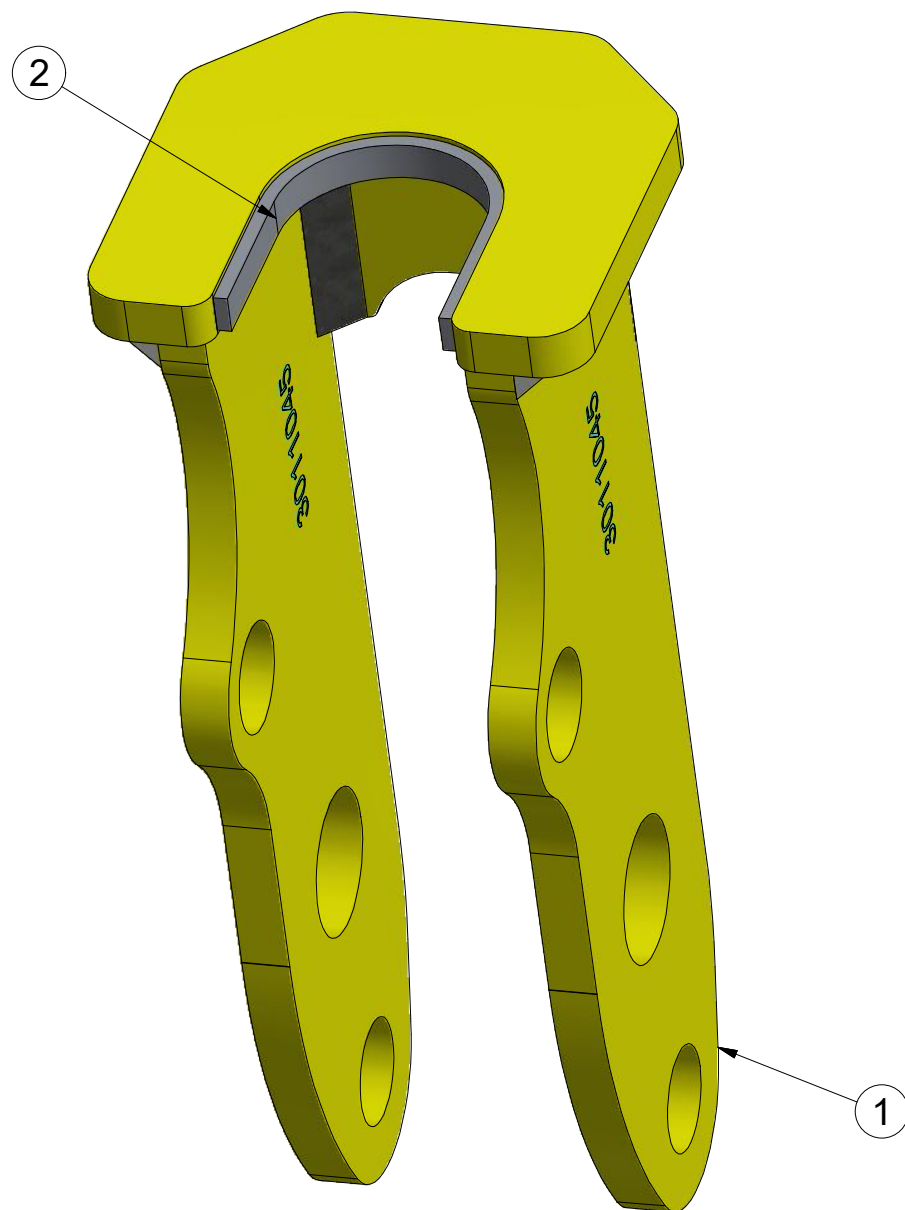

Pos.	Part Number	Pcs.
1	3011045	1
2	m09566	0,18

Ⓒ TÁHLO SKLÁPĚNÍ

Ⓓ ZUGSTANGE ZUR KIPPUNG

Ⓕ TIGES DE L'ESSIEU

4005363

Ⓖ TILTING PULL ROD

Ⓡ ТЯГИ ТРАНСПОРТНОЙ ОСИ

Ⓟ SPRZĘGI OSI

Farmet

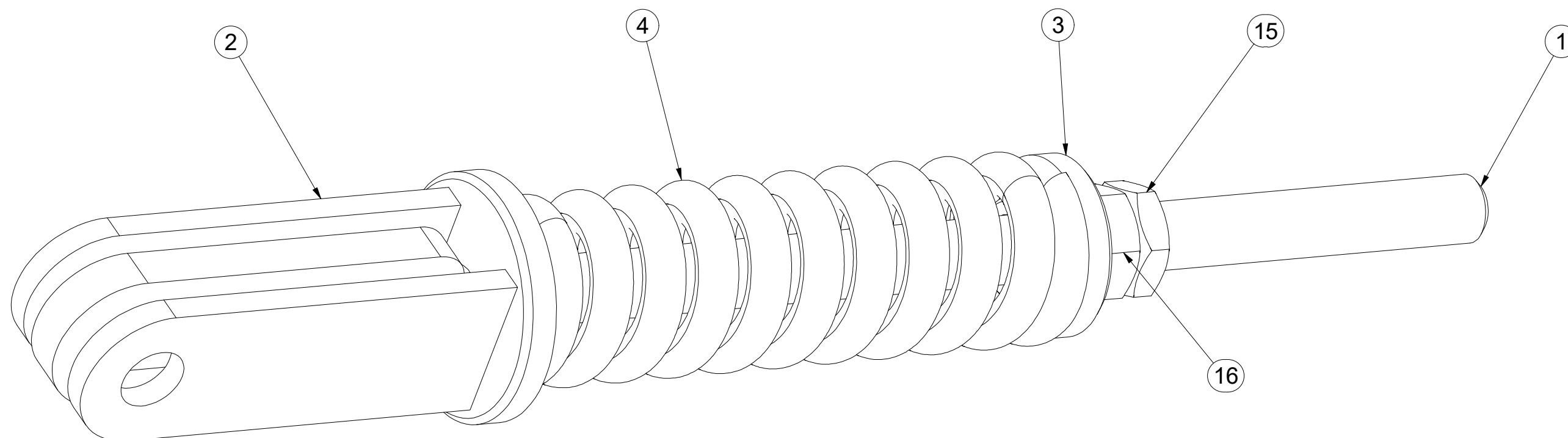

Pos.	Part Number	Pcs.
1	4005358	1
2	4005361	1
3	4000023	1
4	m06482	1
15	m04043	1
16	m01309	1

☉ SPOJOVACÍ TÁHLO

☉ VERBINDUNGSSTANGE

☉ TIGE DE RACCORDEMENT

4003966

☉ CONNECTING ROD

☉ СОЕДИНИТЕЛЬНАЯ ТЯГА

☉ KORBOWÓD

Farmet

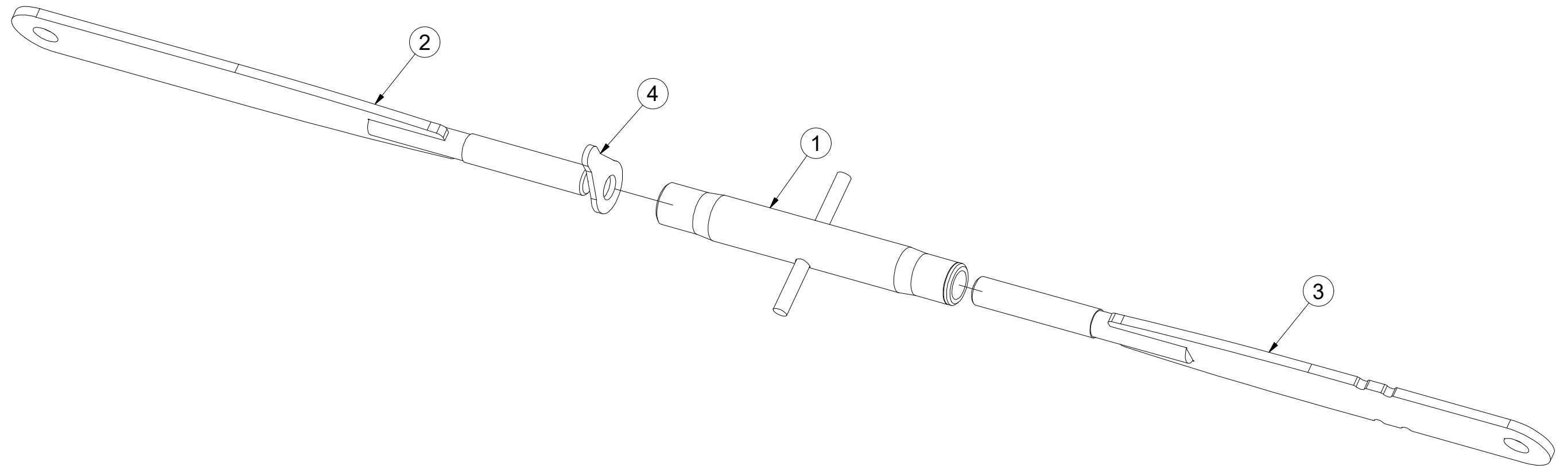
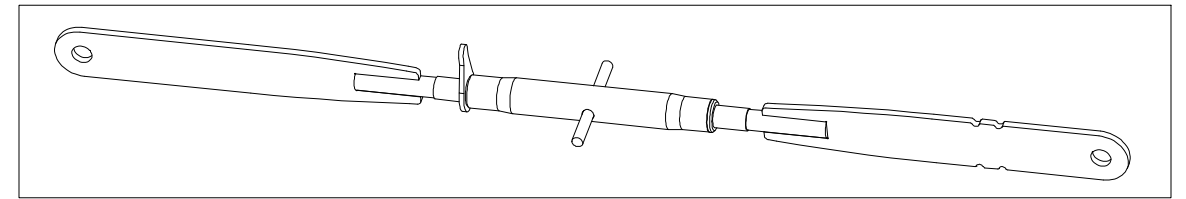

Poz	Číslo součásti	Ks
1	m08880	1
2	4023421	1
3	4023423	1
4	m08881	1

Ⓒ HYDRAULIKA STROJE

Ⓓ HYDRAULIK DER MASCHINE

Ⓕ HYDRAULIQUE DE LA MACHINE

Ⓖ MACHINE HYDRAULICS

Ⓡ ГИДРАВЛИКА МАШИНЫ

Ⓟ HYDRAULIKA MASZYNY



3011328

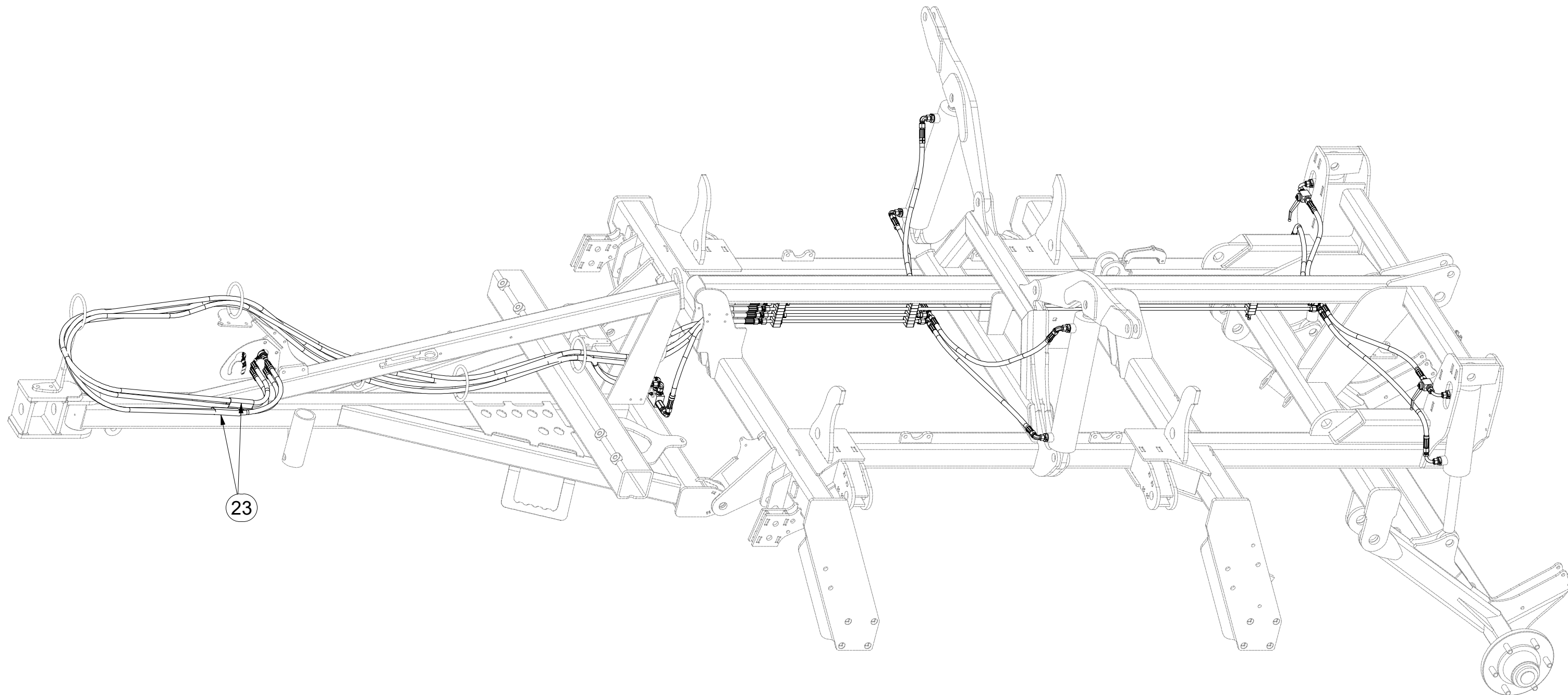

Pos.	Part Number	Pcs.
23	m11183	2

ⒸZ HYDRAULIKA STROJE

Ⓓ HYDRAULIK DER MASCHINE

Ⓕ HYDRAULIQUE DE LA MACHINE

ⒼB MACHINE HYDRAULICS

Ⓔ RU ГИДРАВЛИКА МАШИНЫ

Ⓗ PL HYDRAULIKA MASZYN



3011328

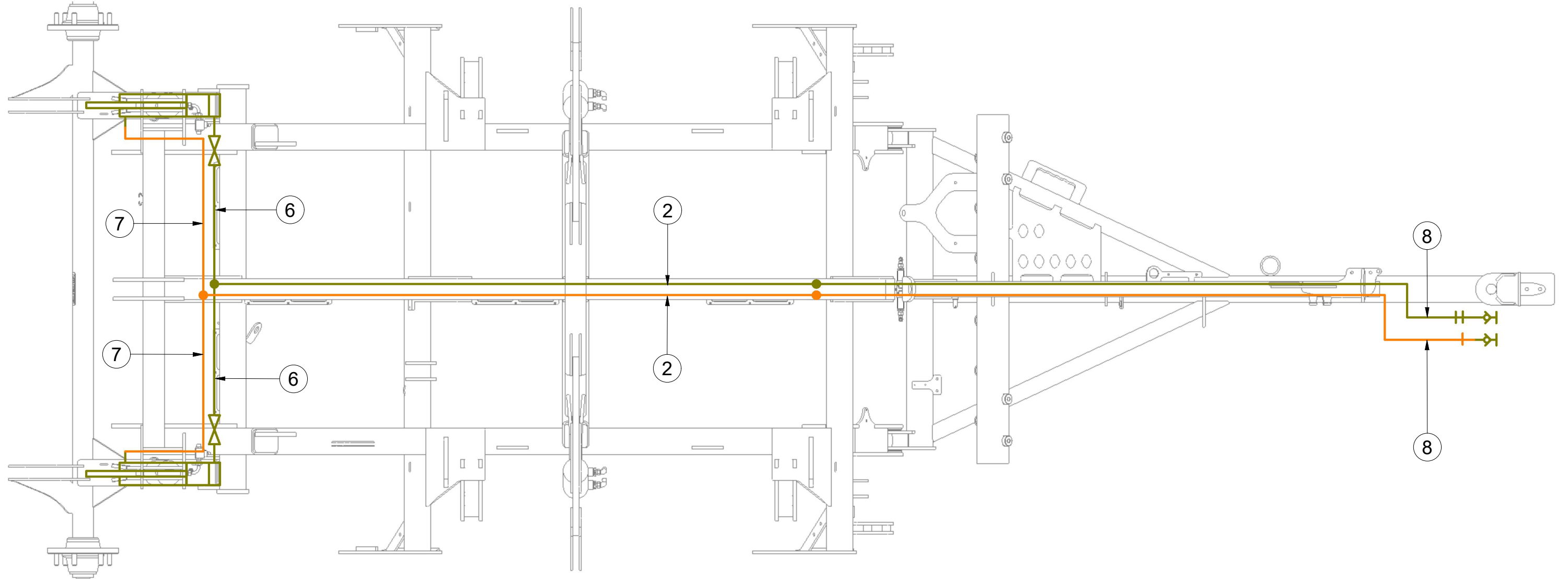

Pos.	Part Number	Pcs.
2	m04803	2
6	m03713	4
7	m04033	2
8	m09431	2

ⒸZ HYDRAULIKA STROJE

ⒸD HYDRAULIK DER MASCHINE

ⒸF HYDRAULIQUE DE LA MACHINE

ⒸGB MACHINE HYDRAULICS

ⒸRU ГИДРАВЛИКА МАШИНЫ

ⒸPL HYDRAULIKA MASZYNY



3011328

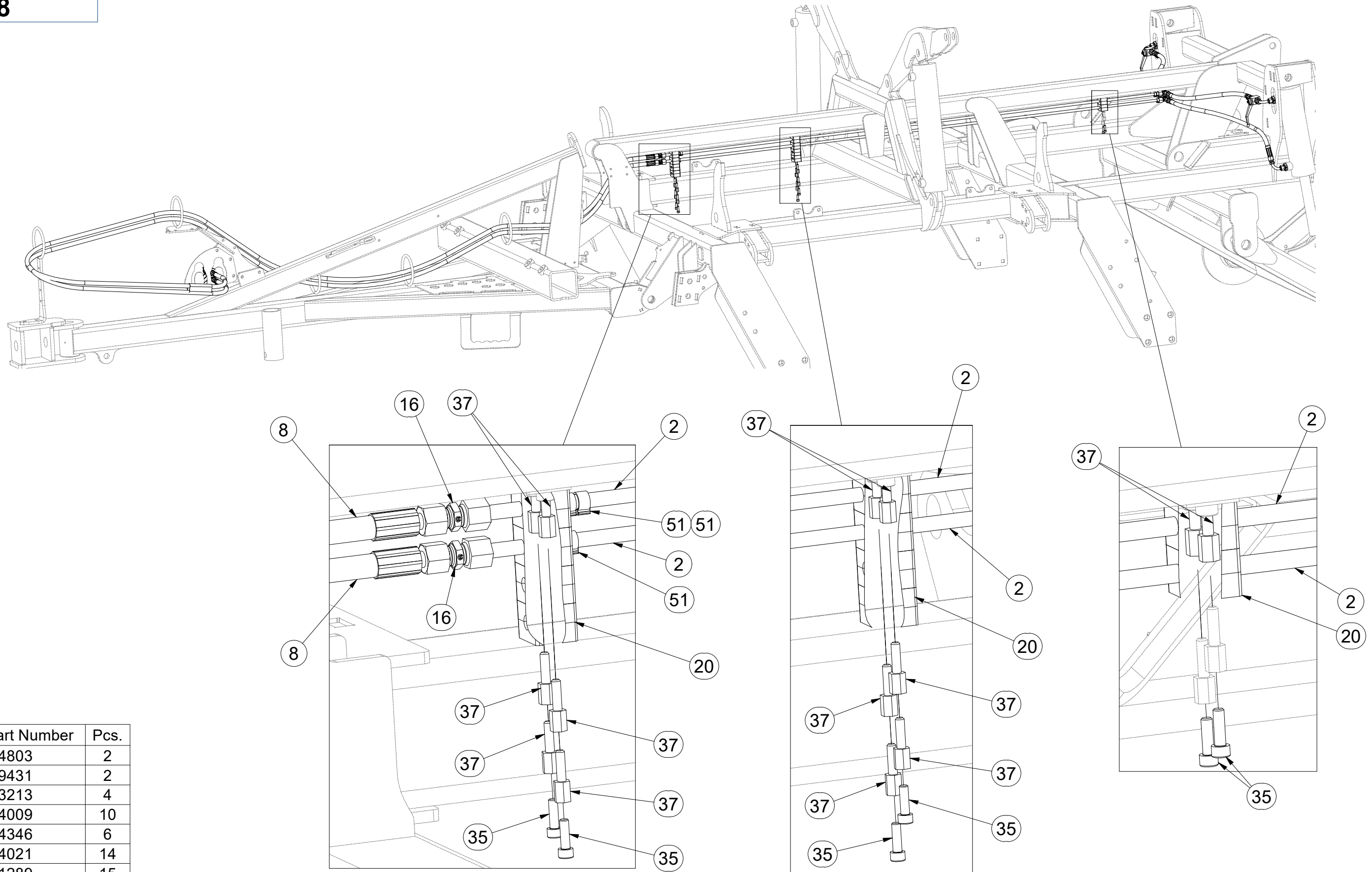

Pos.	Part Number	Pcs.
2	m04803	2
8	m09431	2
16	m03213	4
20	m04009	10
35	m04346	6
37	m04021	14
51	m11289	15

CZ HYDRAULIKA STROJE
 D HYDRAULIK DER MASCHINE
 F HYDRAULIQUE DE LA MACHINE

GB MACHINE HYDRAULICS
 RU ГИДРАВЛИКА МАШИНЫ
 PL HYDRAULIKA MASZYNY



3011328

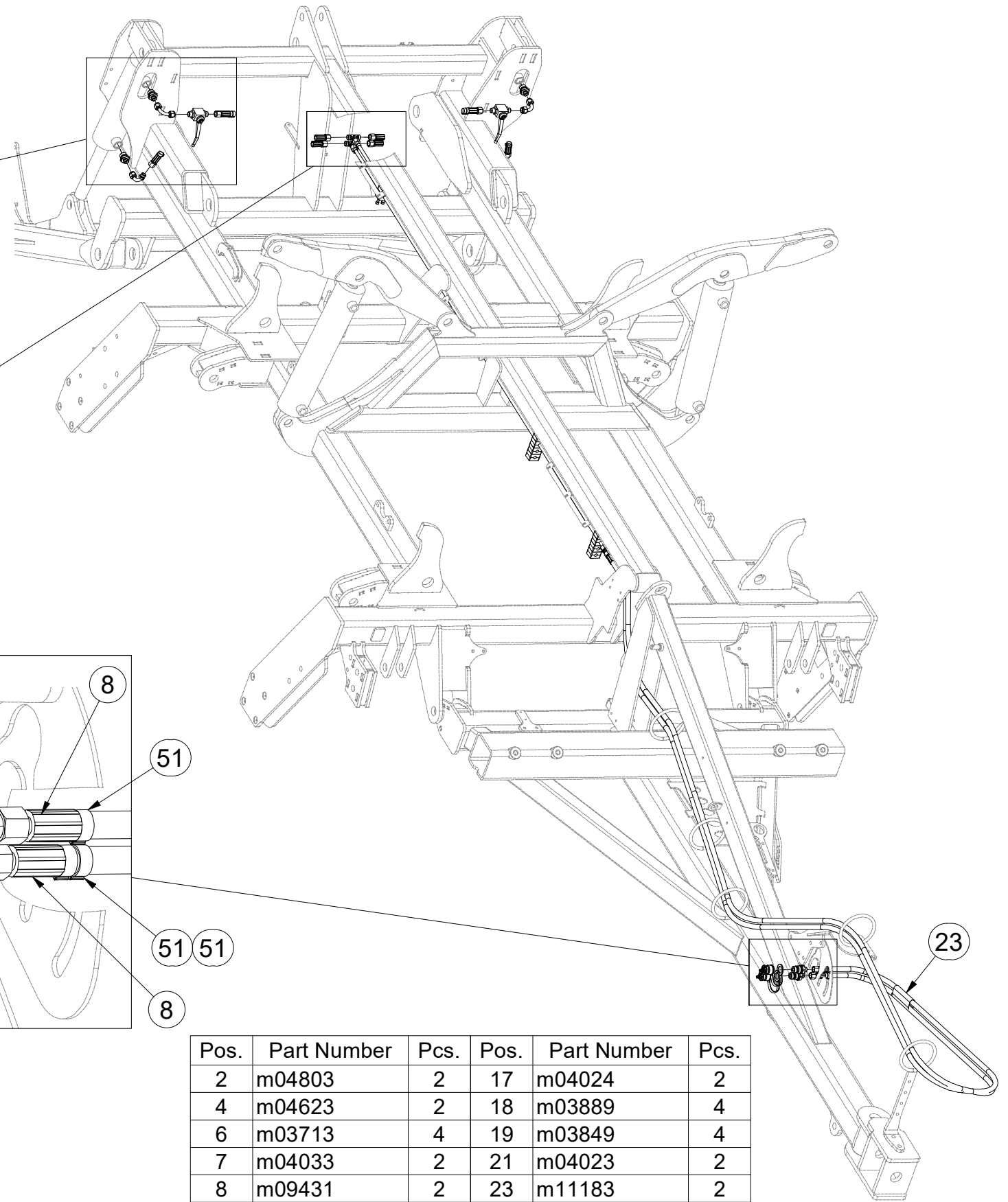
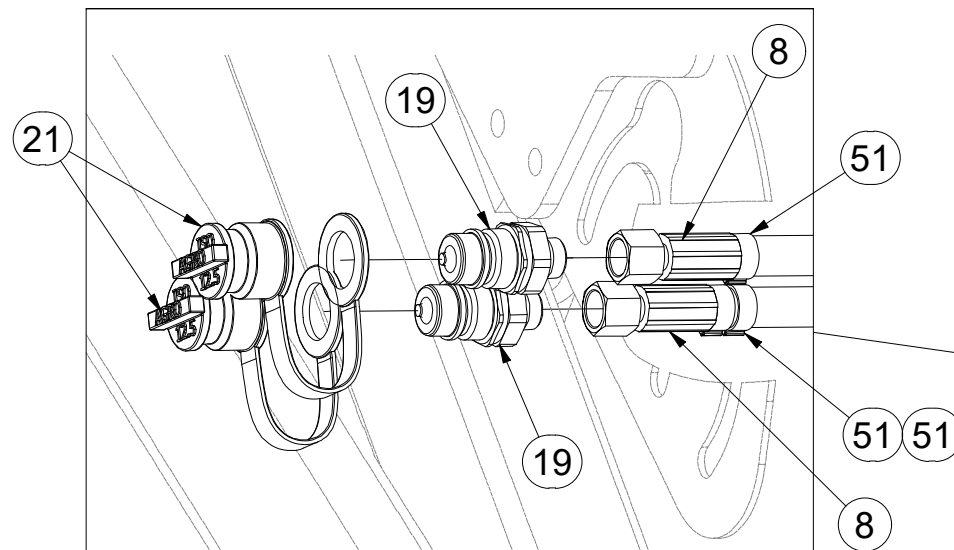
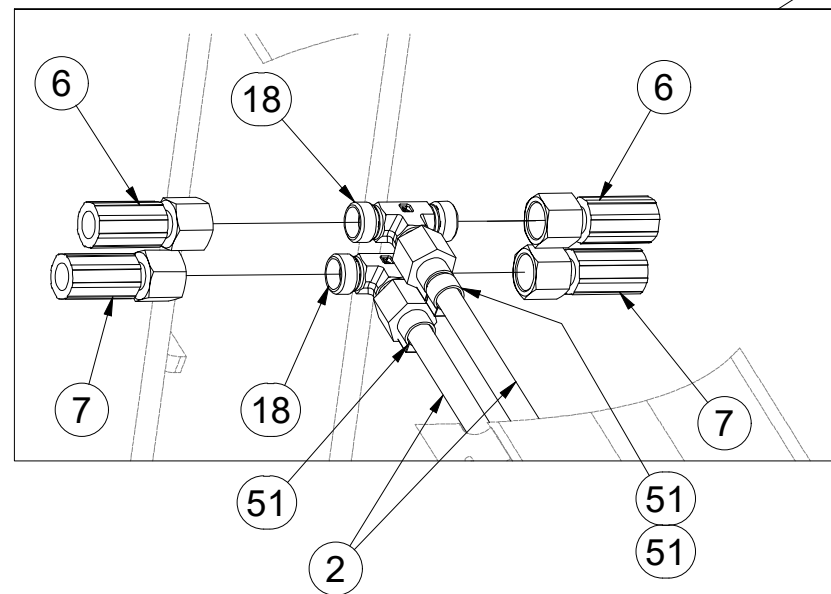
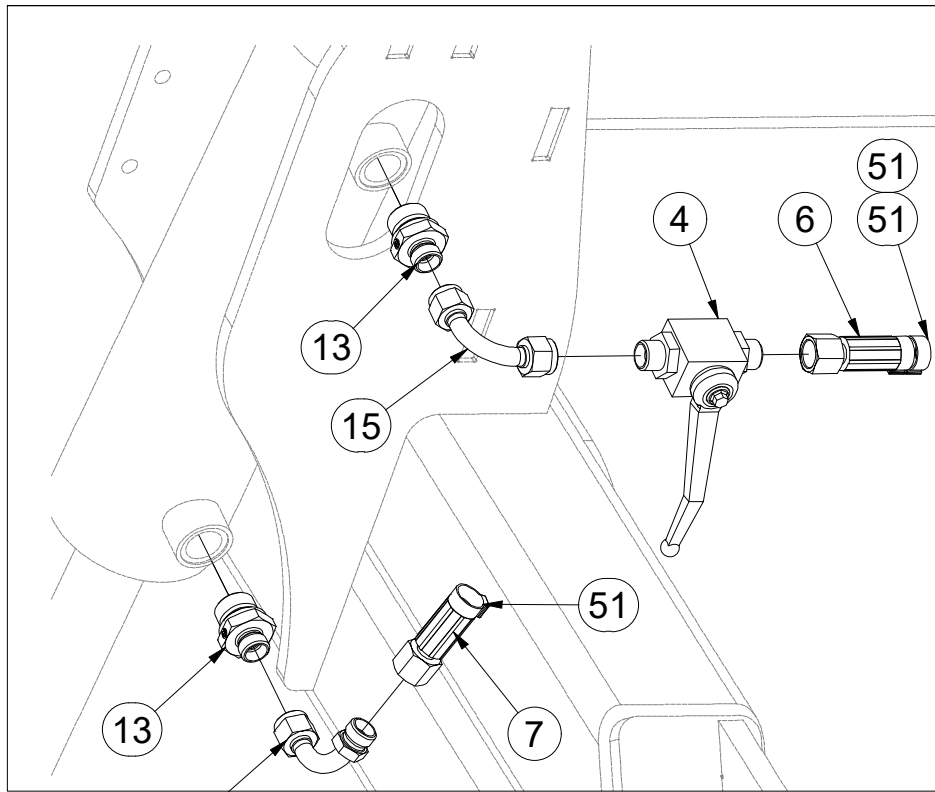

Pos.	Part Number	Pcs.	Pos.	Part Number	Pcs.
2	m04803	2	17	m04024	2
4	m04623	2	18	m03889	4
6	m03713	4	19	m03849	4
7	m04033	2	21	m04023	2
8	m09431	2	23	m11183	2
13	m09934	8	51	m11289	15
15	m04621	2			

CZ HYDRAULIKA STROJE
 D HYDRAULIK DER MASCHINE
 F HYDRAULIQUE DE LA MACHINE

GB MACHINE HYDRAULICS
 RU ГИДРАВЛИКА МАШИНЫ
 PL HYDRAULIKA MASZYNY



3011328

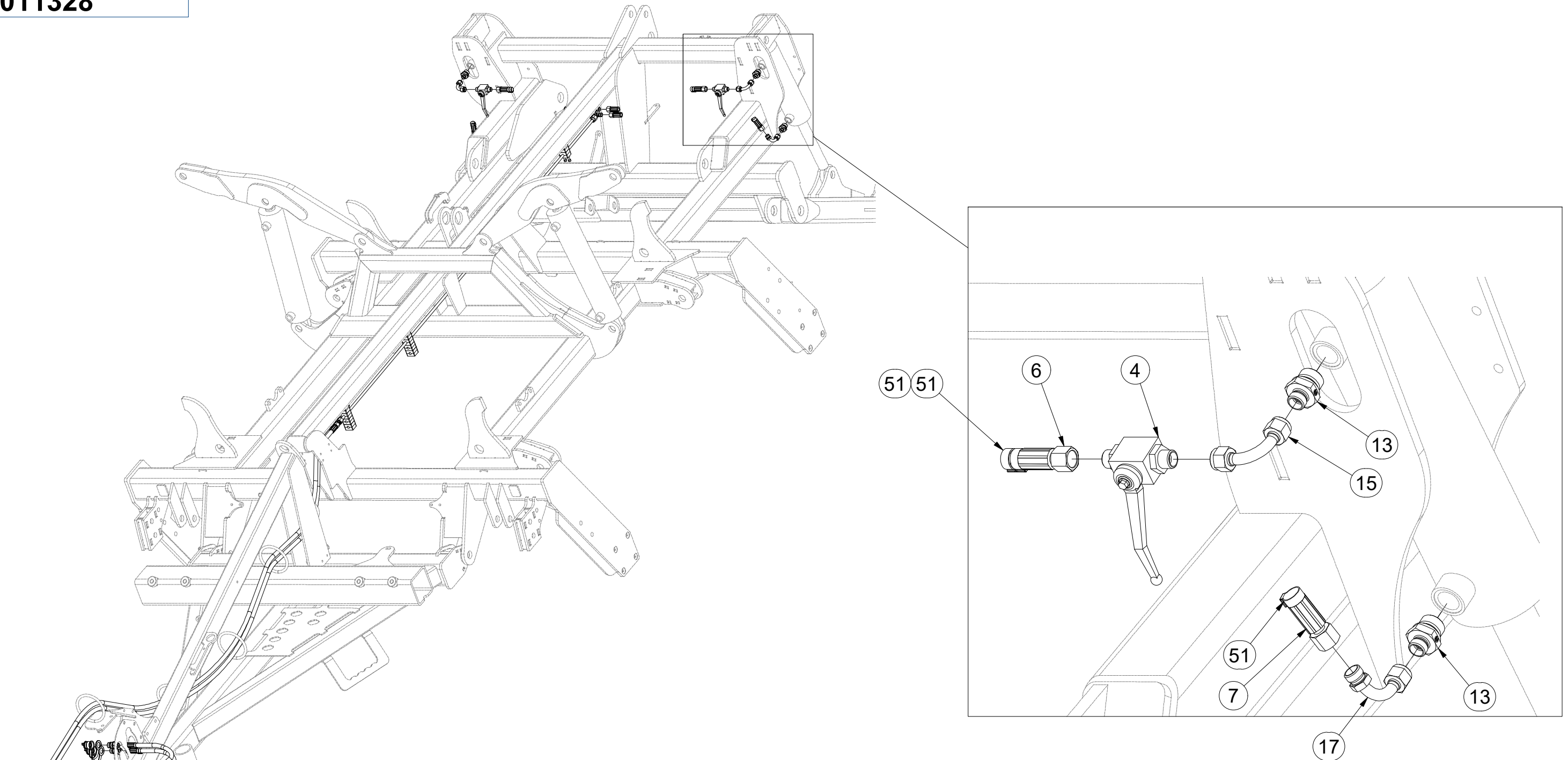

Pos.	Part Number	Pcs.
4	m04623	2
6	m03713	4
7	m04033	2
13	m09934	8
15	m04621	2
17	m04024	2
51	m11289	15

3011328

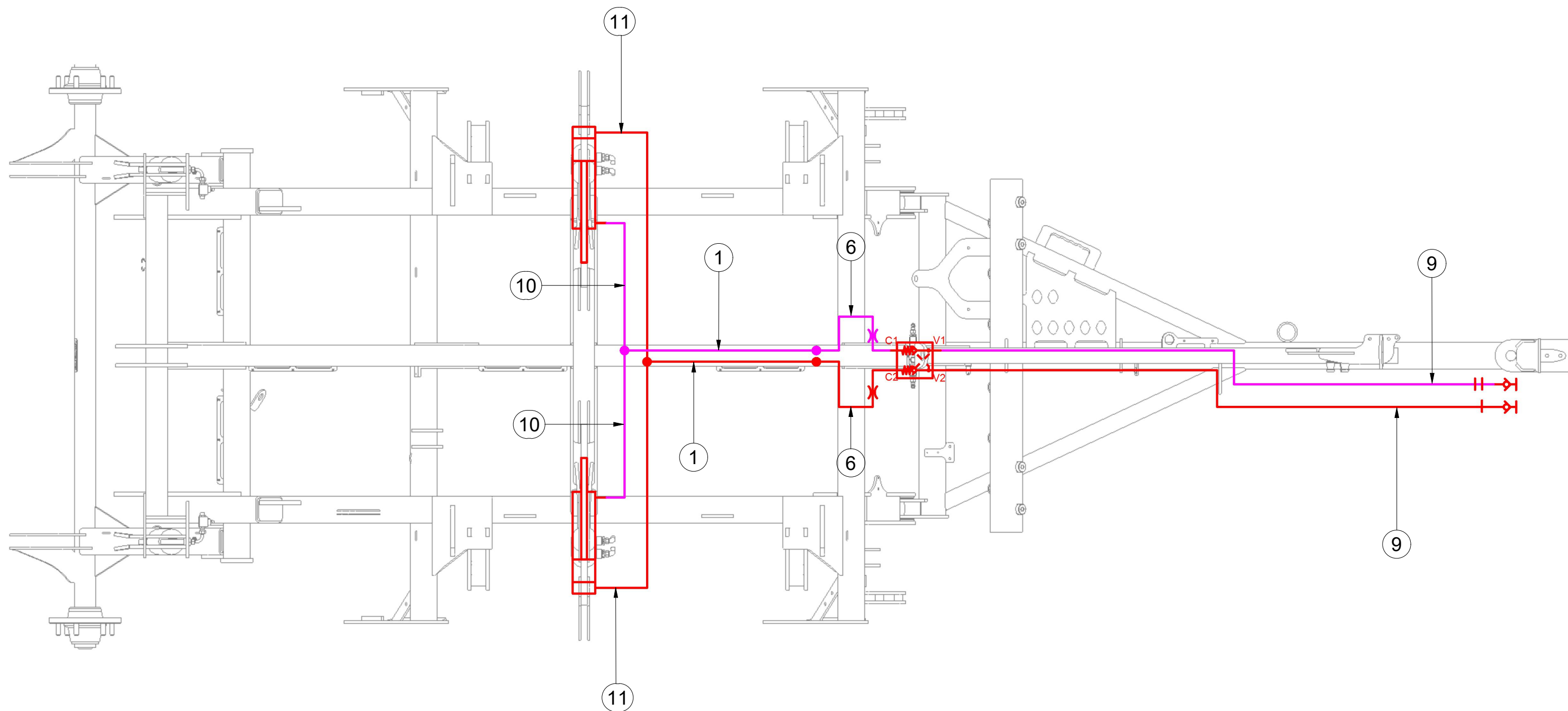

Pos.	Part Number	Pcs.
1	m03975	2
6	m03713	4
9	m04087	2
10	m07646	2
11	m07909	2

3011328

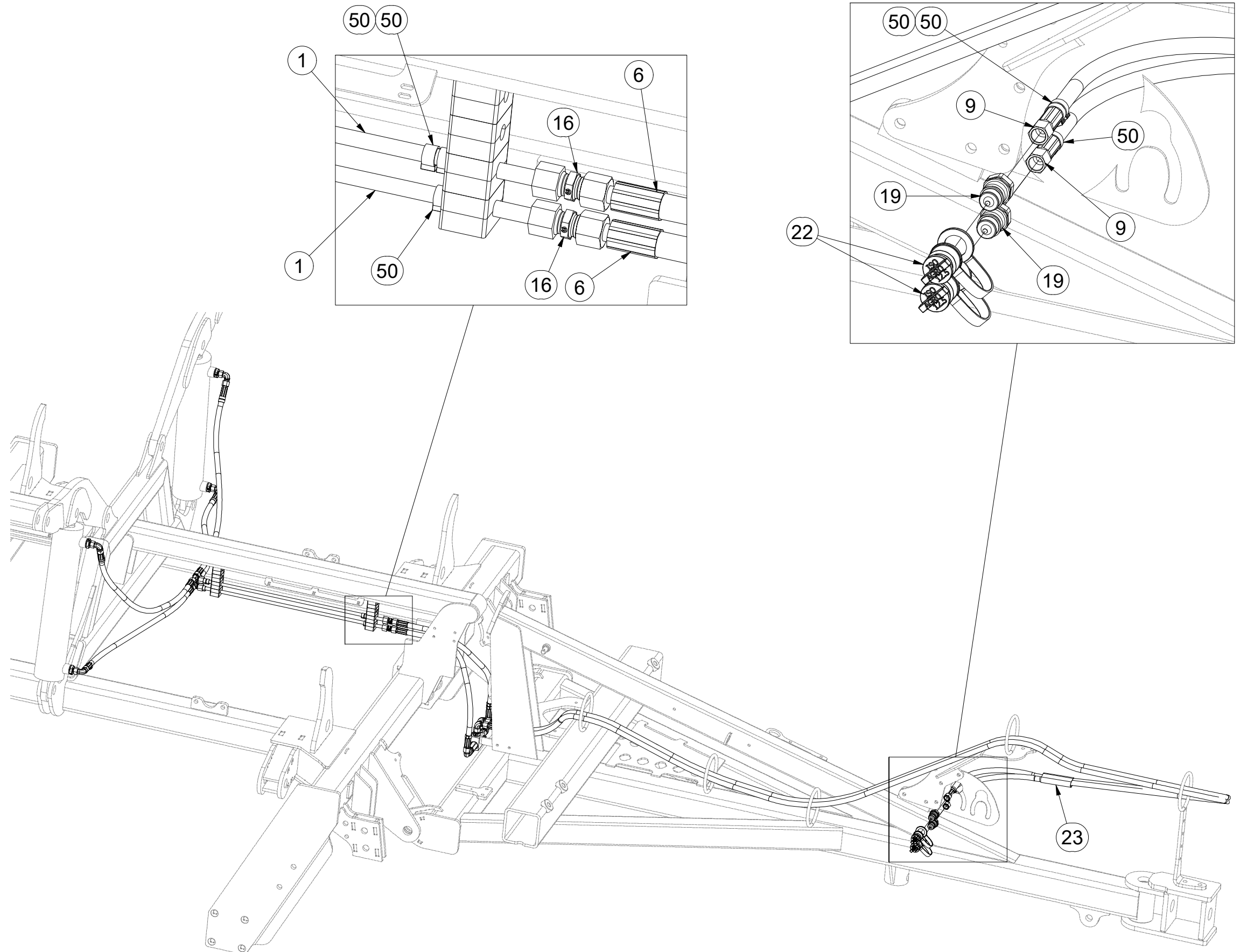

Pos.	Part Number	Pcs.
1	m03975	2
6	m03713	4
9	m04087	2
16	m03213	4
19	m03849	4
22	m04022	2
23	m11183	2
50	m11294	21

ⒸZ HYDRAULIKA STROJE

Ⓓ HYDRAULIK DER MASCHINE

Ⓕ HYDRAULIQUE DE LA MACHINE

ⒸB MACHINE HYDRAULICS

ⒸR ГИДРАВЛИКА МАШИНЫ

ⒸL HYDRAULIKA MASZYNY



3011328

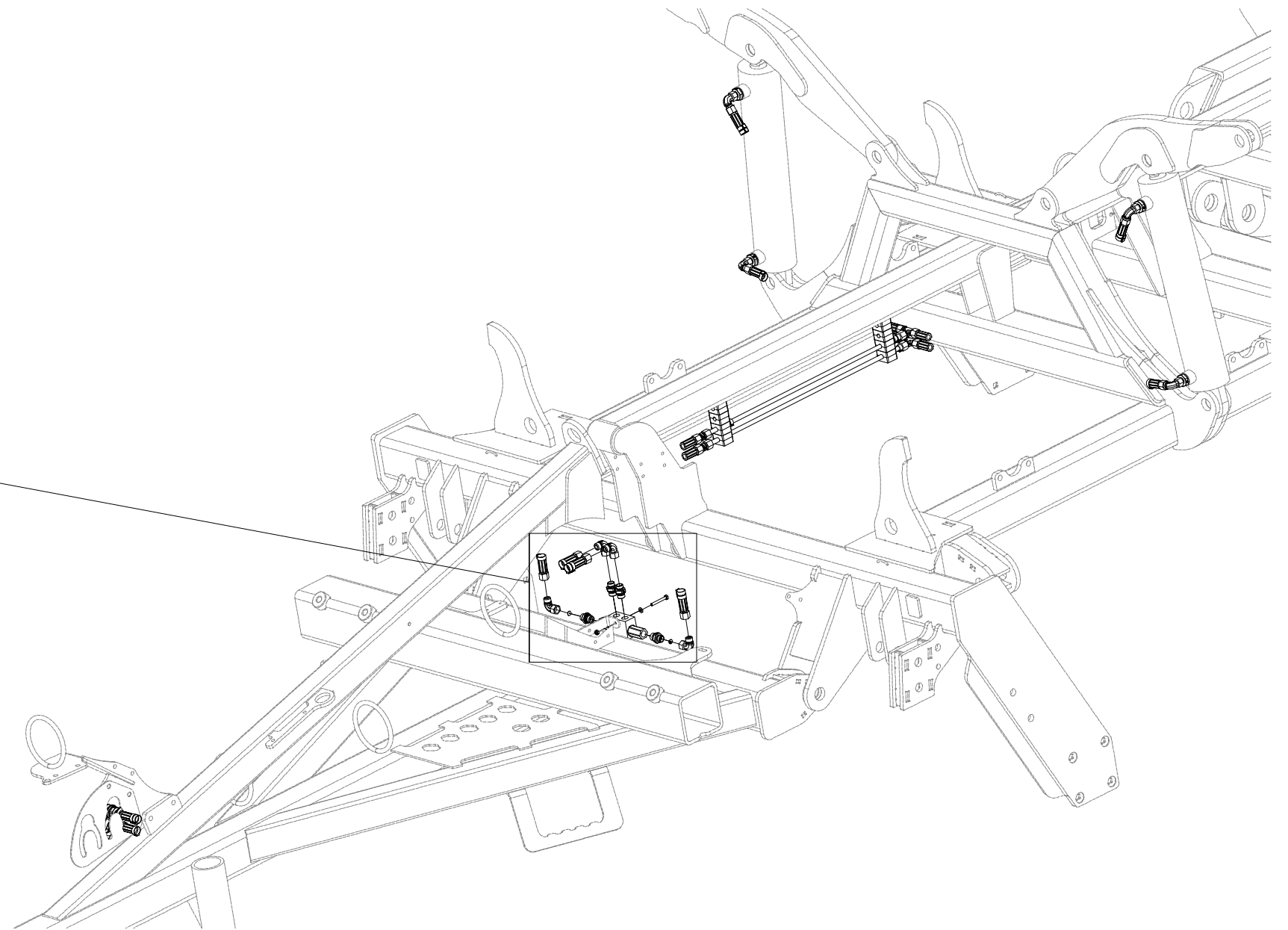
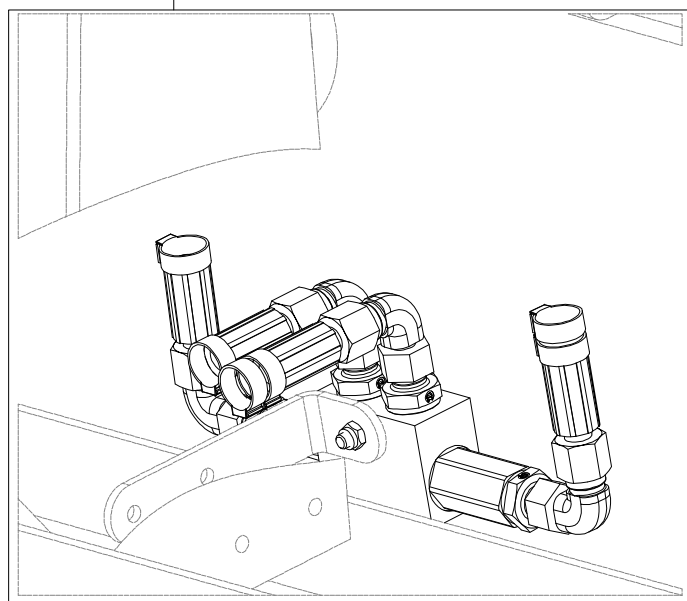
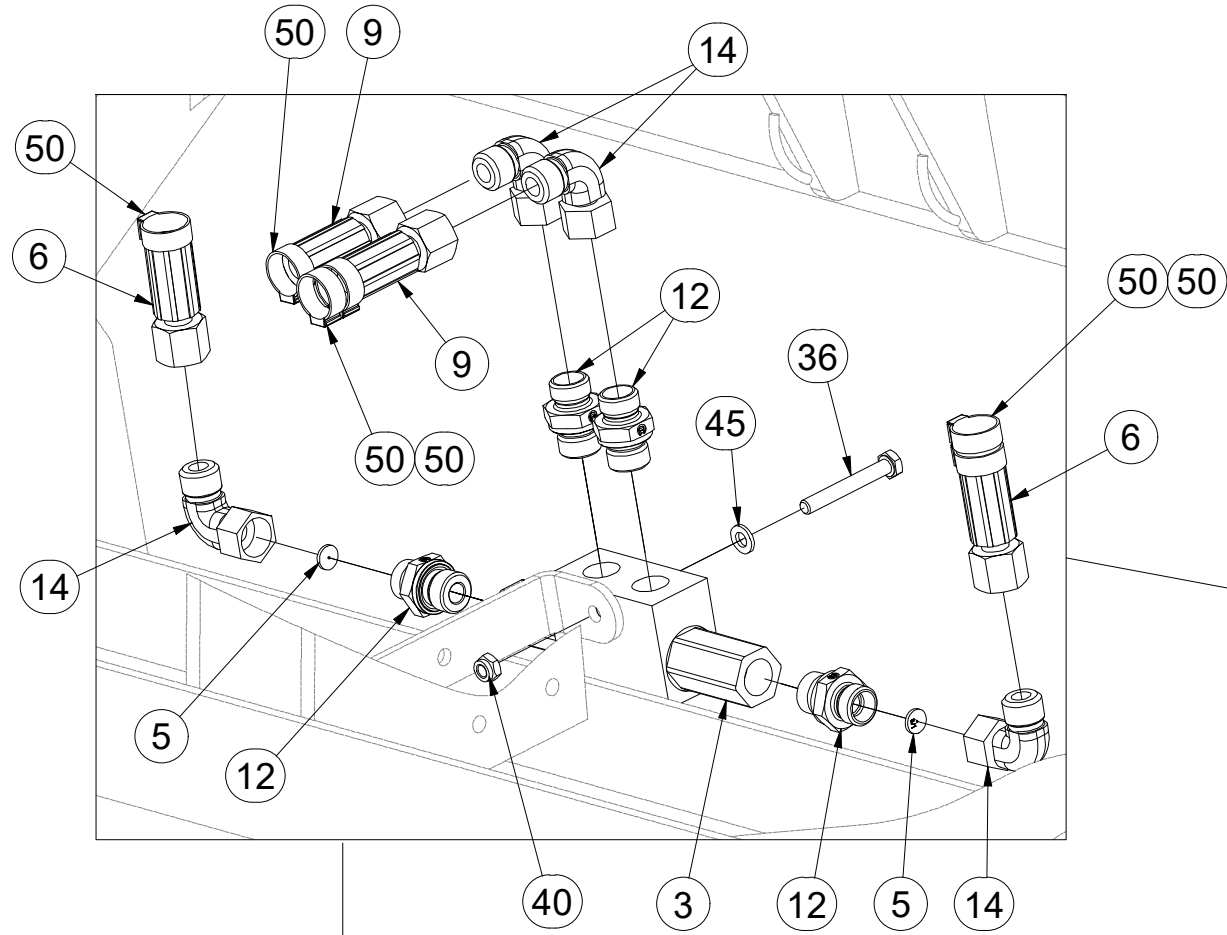

Pos.	Part Number	Pcs.
3	m06673	1
5	m10780	2
6	m03713	4
9	m04087	2
12	m06528	4
14	m06803	8
36	m05561	1
40	m05560	1
45	m01199	1
50	m11294	21

CZ HYDRAULIKA STROJE
 D HYDRAULIK DER MASCHINE
 F HYDRAULIQUE DE LA MACHINE

GB MACHINE HYDRAULICS
 RU ГИДРАВЛИКА МАШИНЫ
 PL HYDRAULIKA MASZYNY



3011328

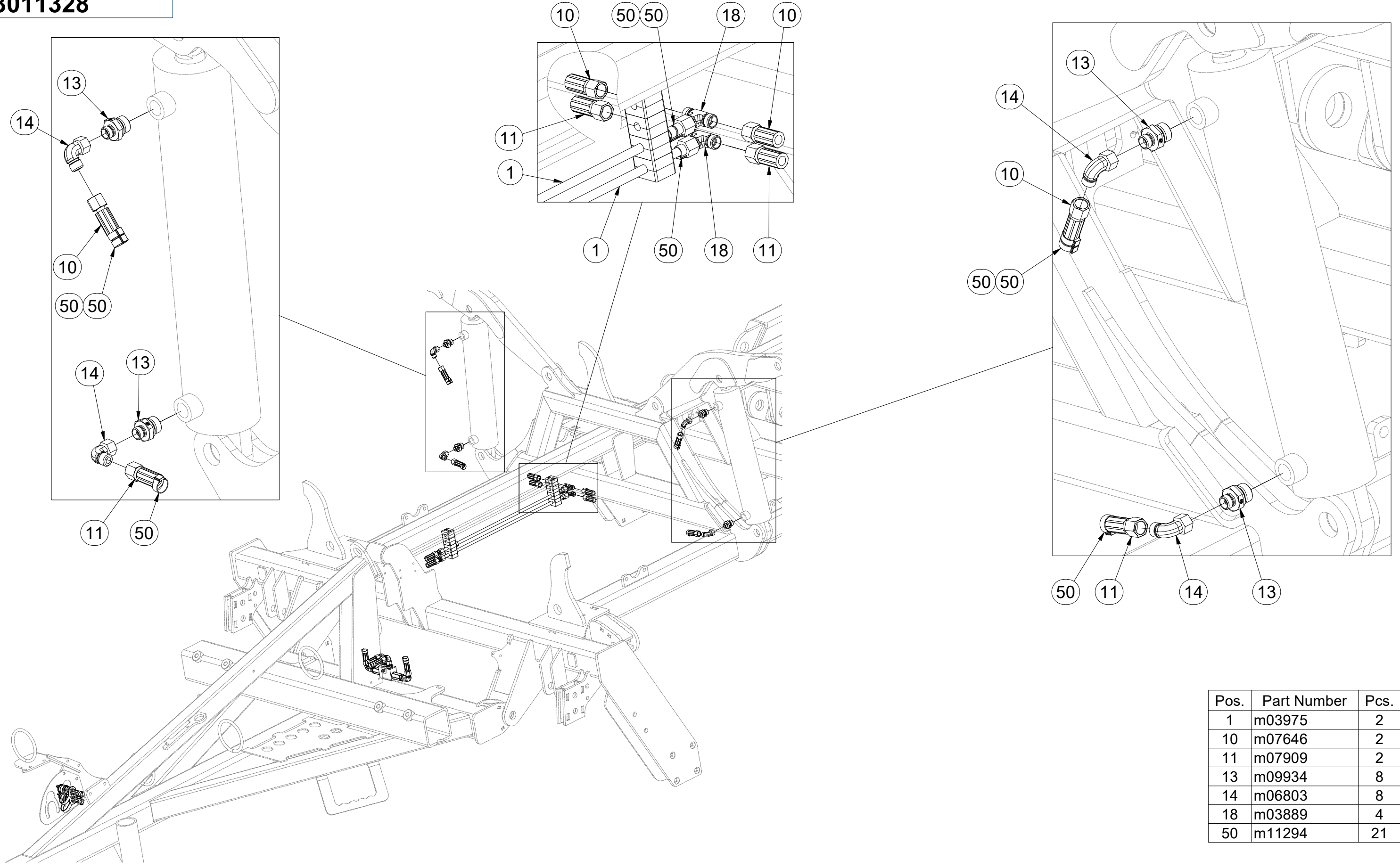

Pos.	Part Number	Pcs.
1	m03975	2
10	m07646	2
11	m07909	2
13	m09934	8
14	m06803	8
18	m03889	4
50	m11294	21

Ⓒ CZ OJ T3

Ⓓ DEICHSEL T3

Ⓕ TIMON T3

Ⓖ GB TOW BAR T3

Ⓡ RU ДЫШЛО T3

Ⓟ PL DYSZEL T3



3012414

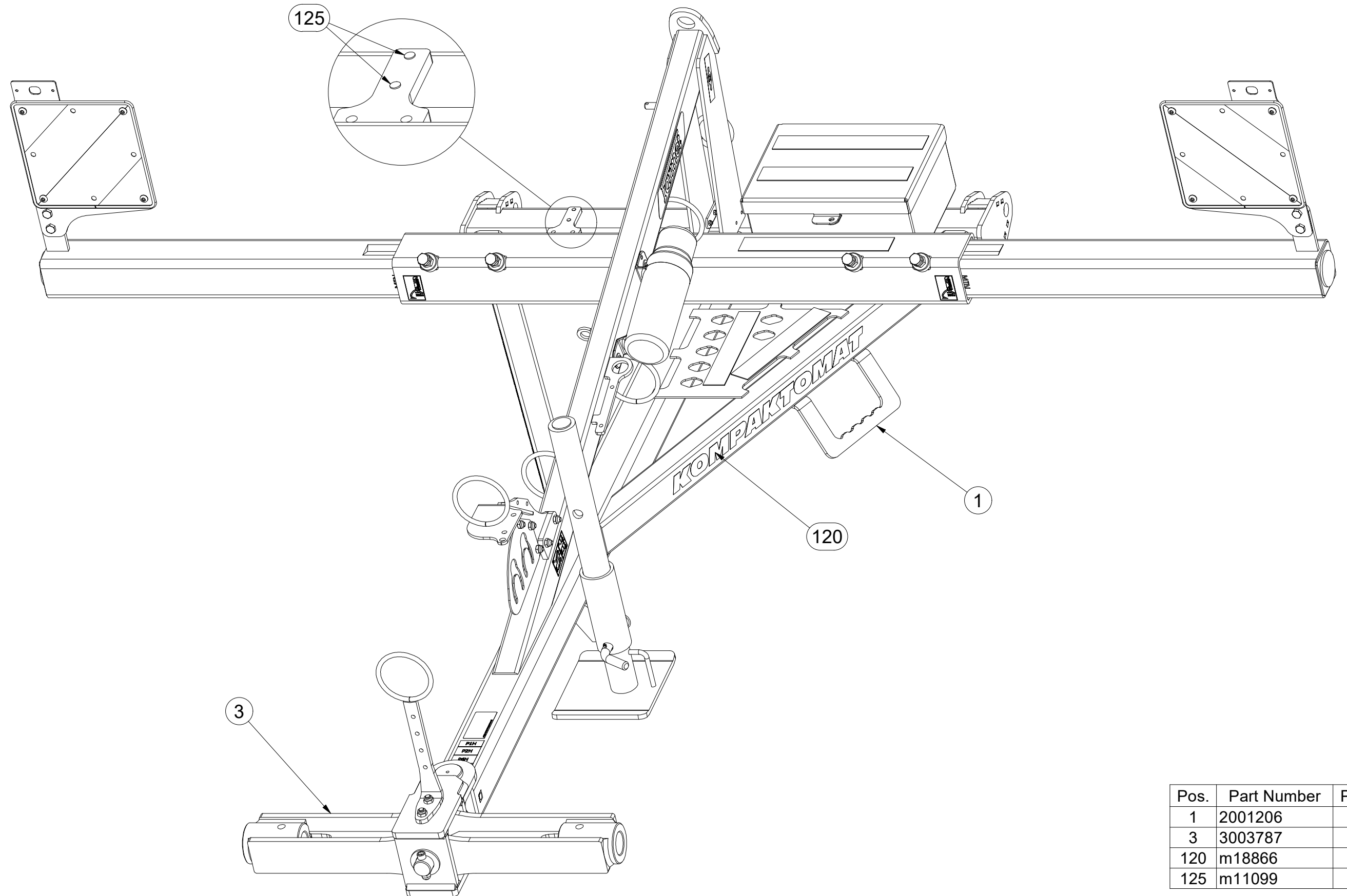

Pos.	Part Number	Pcs.
1	2001206	1
3	3003787	1
120	m18866	1
125	m11099	2

ⒸZ OJ T3

Ⓓ DEICHSEL T3

Ⓕ TIMON T3

ⒸB TOW BAR T3

ⒸR ДЫШЛО T3

ⒸL DYSZEL T3



3012414

Pos.	Part Number	Pcs.	Pos.	Part Number	Pcs.
1	2001206	1	72	m04613	2
2	3009637	1	74	m03926	2
3	3003787	1	75	m03681	3
4	4003744	2	76	m14008	2
5	4008049	1	86	m03775	5
6	4014570	1	88	m04301	8
10	8000647-40207	1	90	m02533	1
11	4012205	1	101	m03866	1
13	3012460	1	102	4013139	2
15	4019191	1	110	m10451	1
17	4008679	1	115	m03959	1
30	m10454	1			

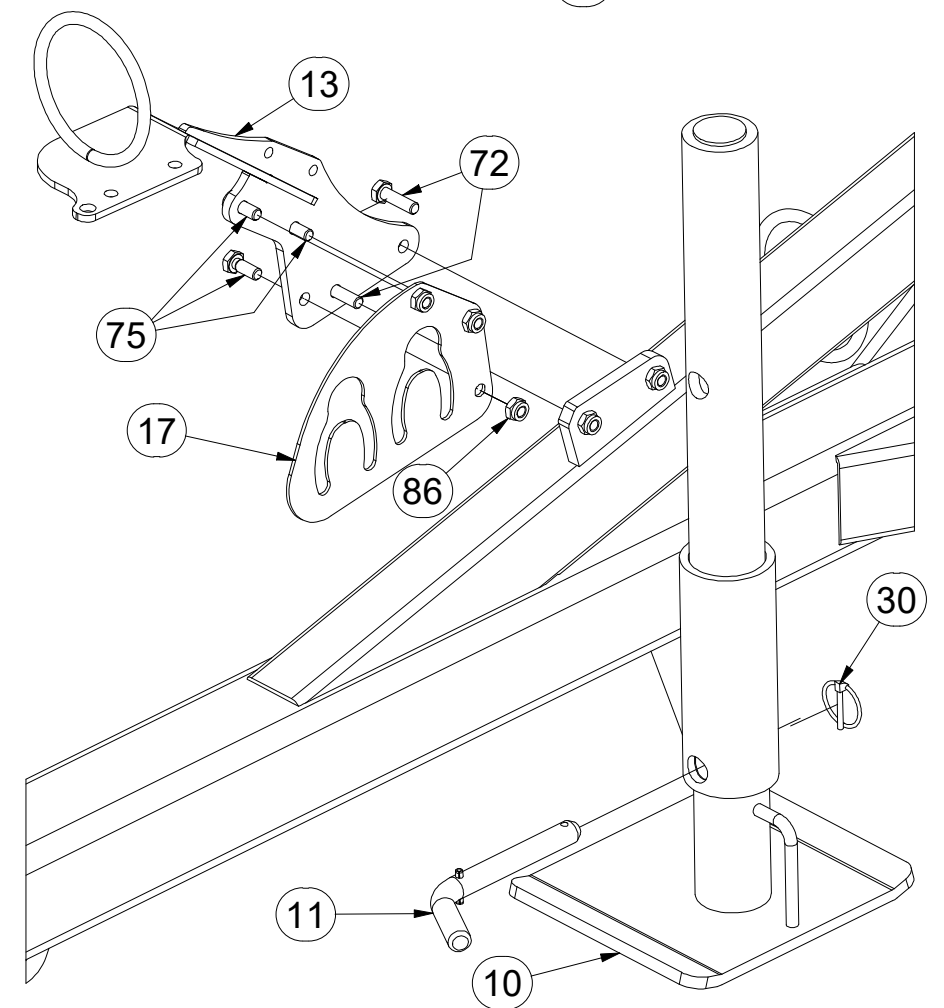
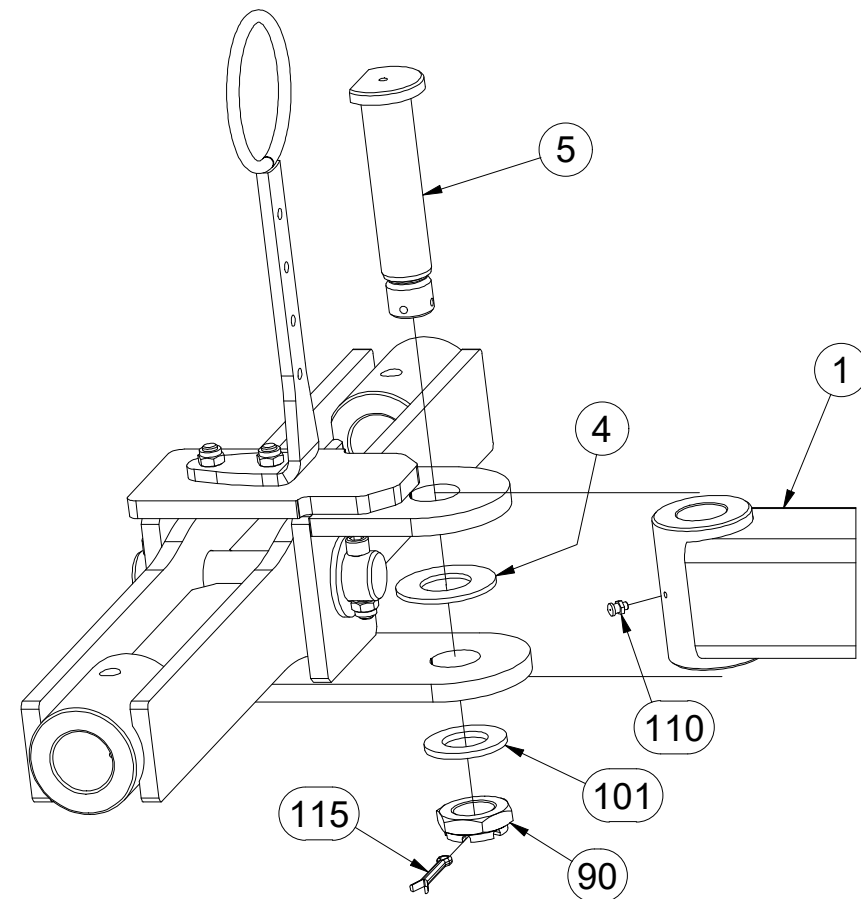
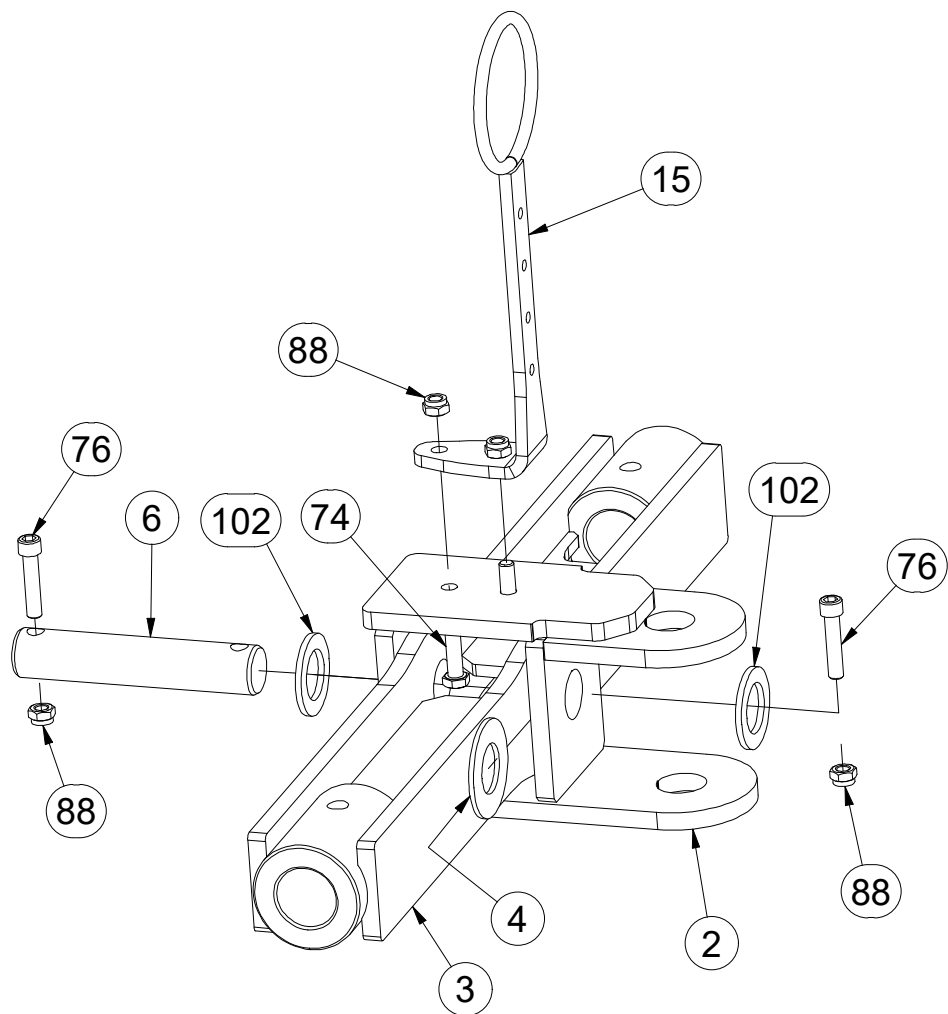
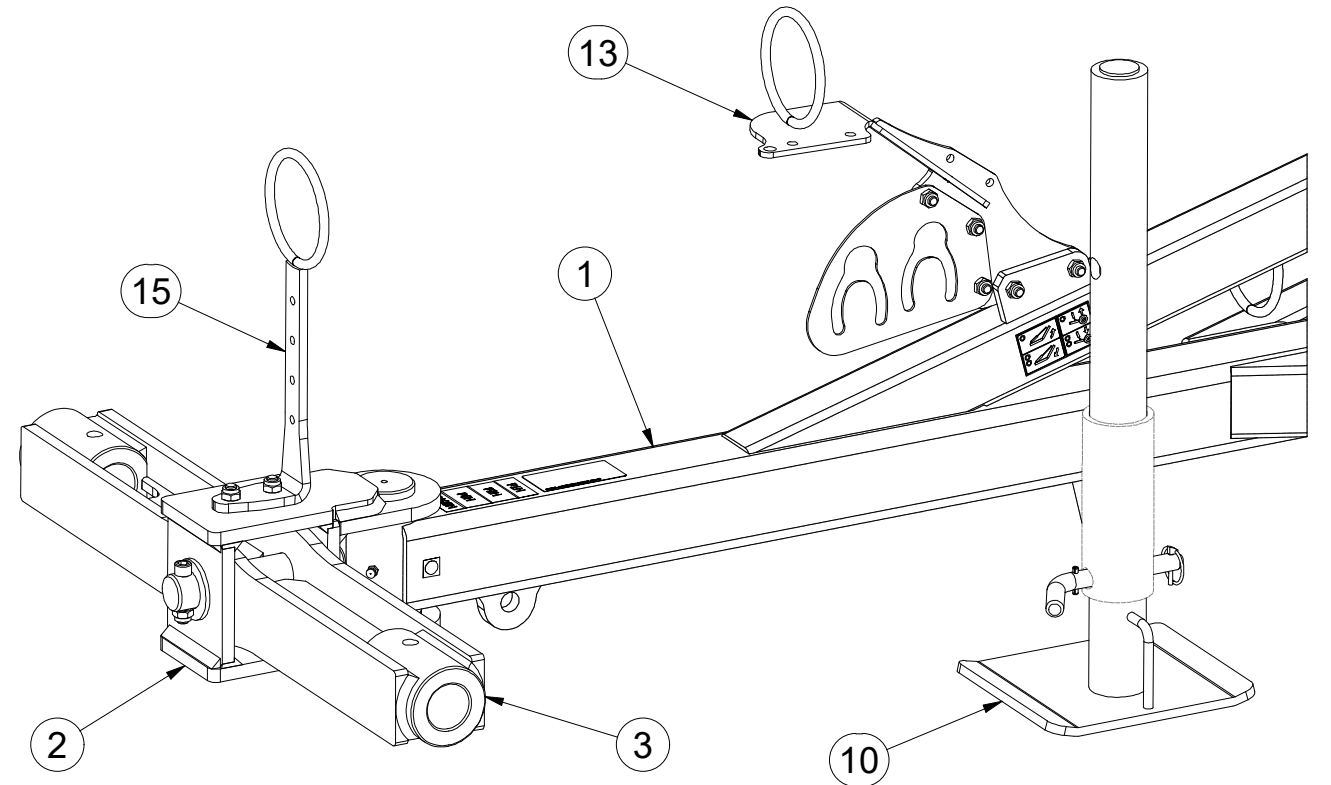

Ⓒ CZ OJ T3

Ⓓ DEICHSEL T3

Ⓕ TIMON T3

Ⓖ GB TOW BAR T3

Ⓡ RU ДЫШЛО T3

Ⓟ PL DYSZEL T3



3012414

Pos.	Part Number	Pcs.	Pos.	Part Number	Pcs.
1	2001206	1	73	m04039	4
7	4019255	2	77	m02254	4
8	VZ00024252	1	78	m17098	2
9	VZ00024253	1	85	m05560	4
12	m12296	1	87	m04503	3
14	4013461	1	88	m04301	8
31	m15900	1	89	m01306	4
50	m02579	2	100	m07936	3
70	m01074	2	103	m16612	4
71	m01092	3			

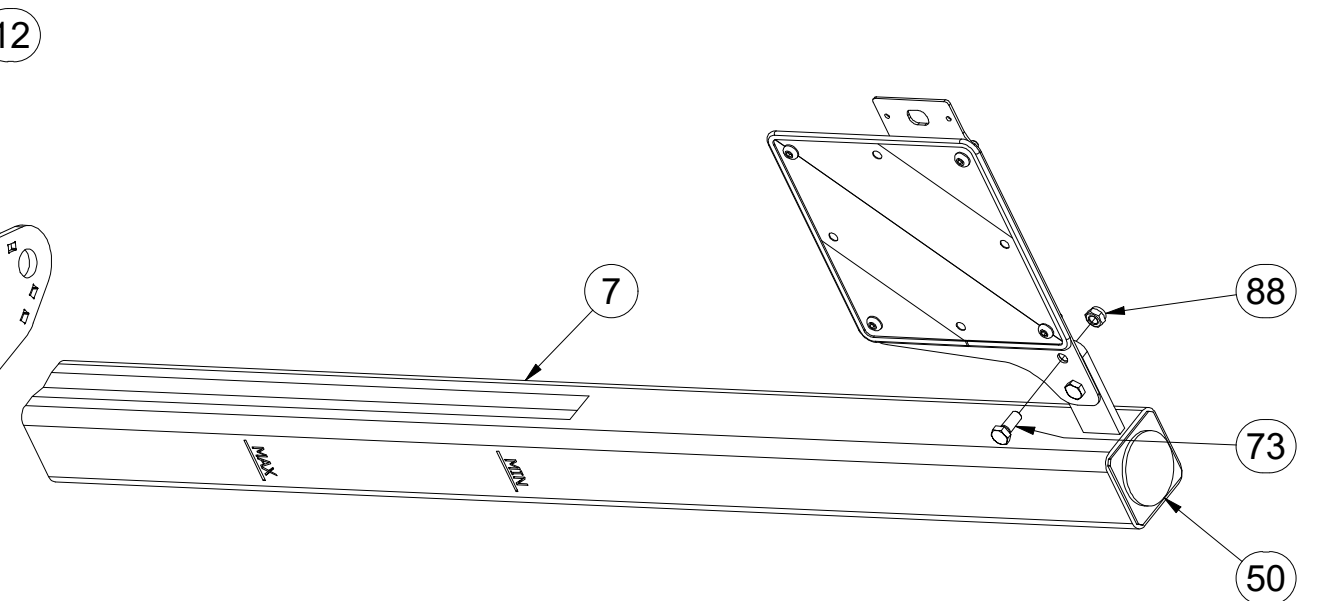
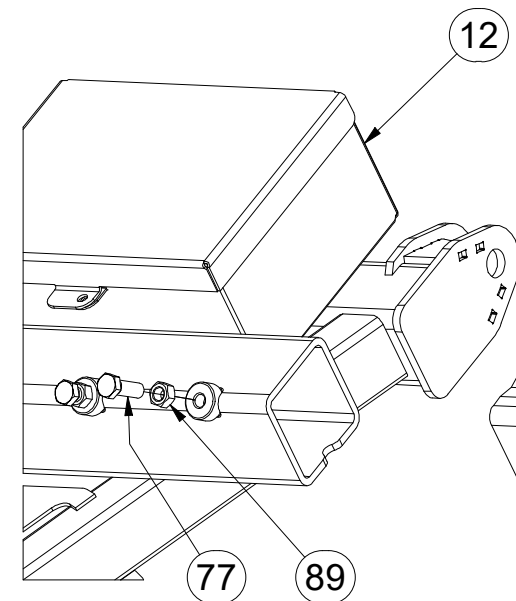
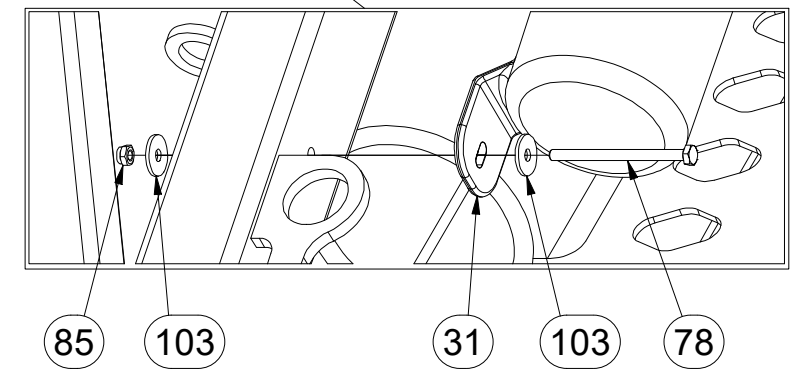
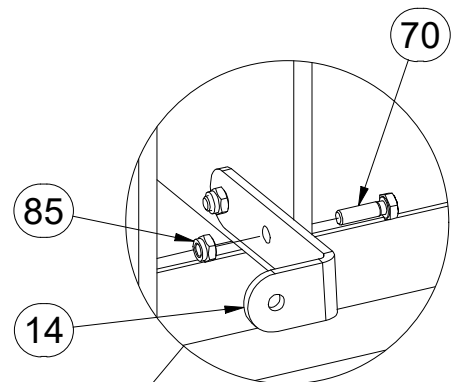
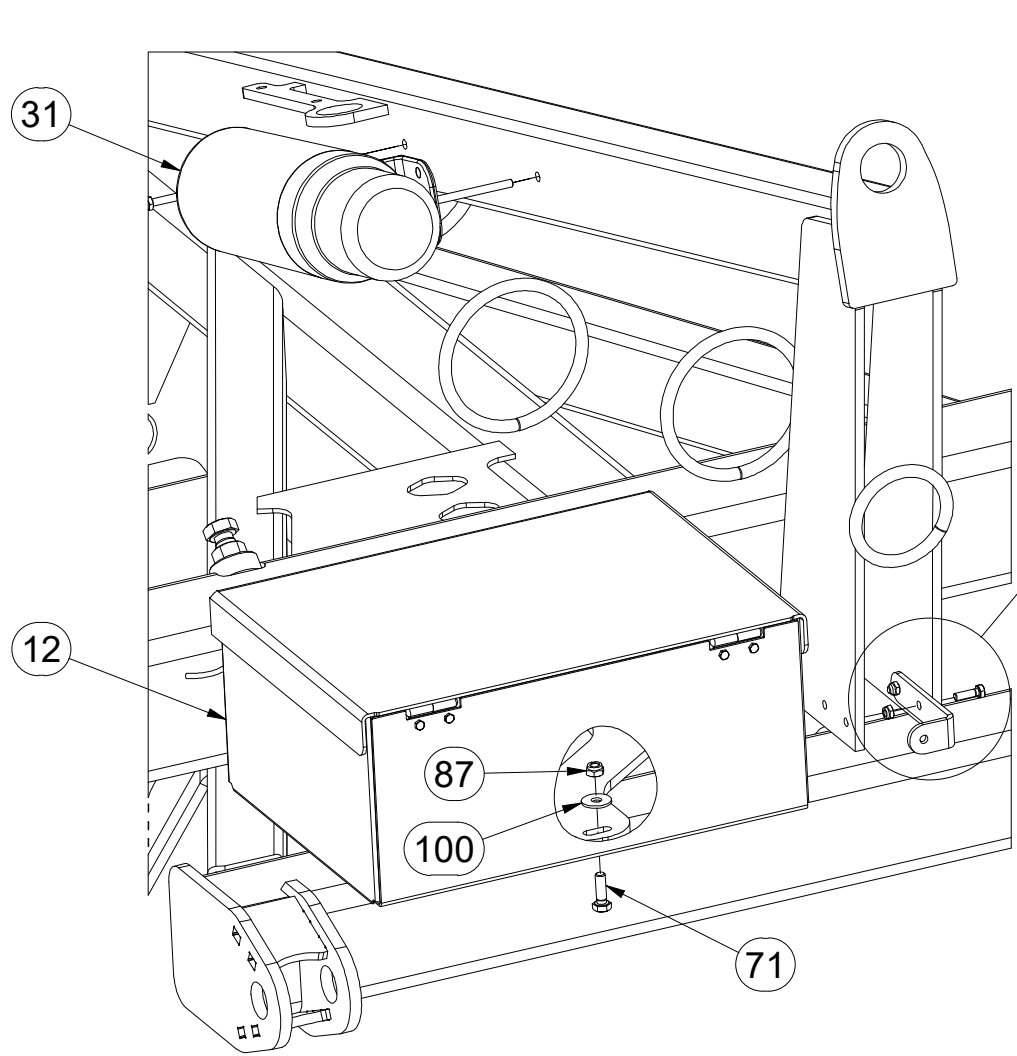
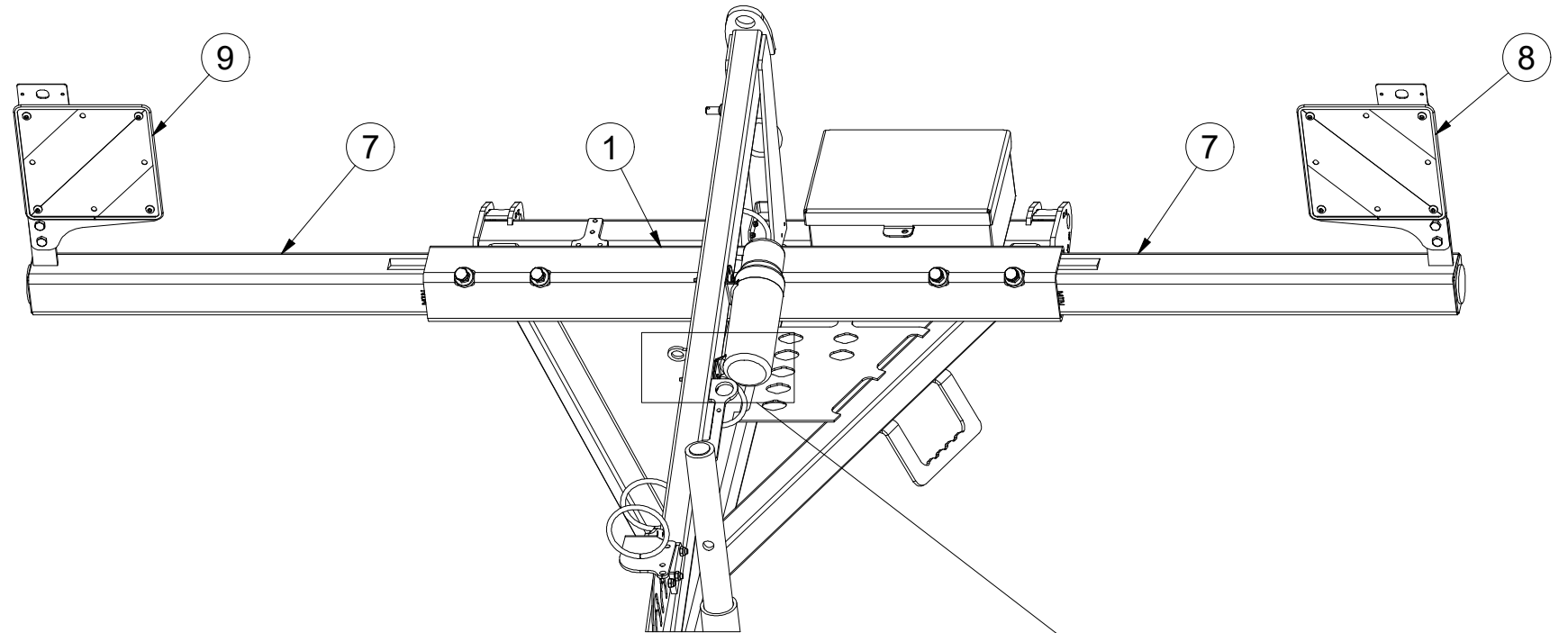

Ⓒ CZ OJ T3

Ⓓ DEICHSEL T3

Ⓕ TIMON T3

m18866

Ⓖ GB TOW BAR T3

Ⓒ RU ДЫШЛО T3

Ⓖ PL DYSZEL T3

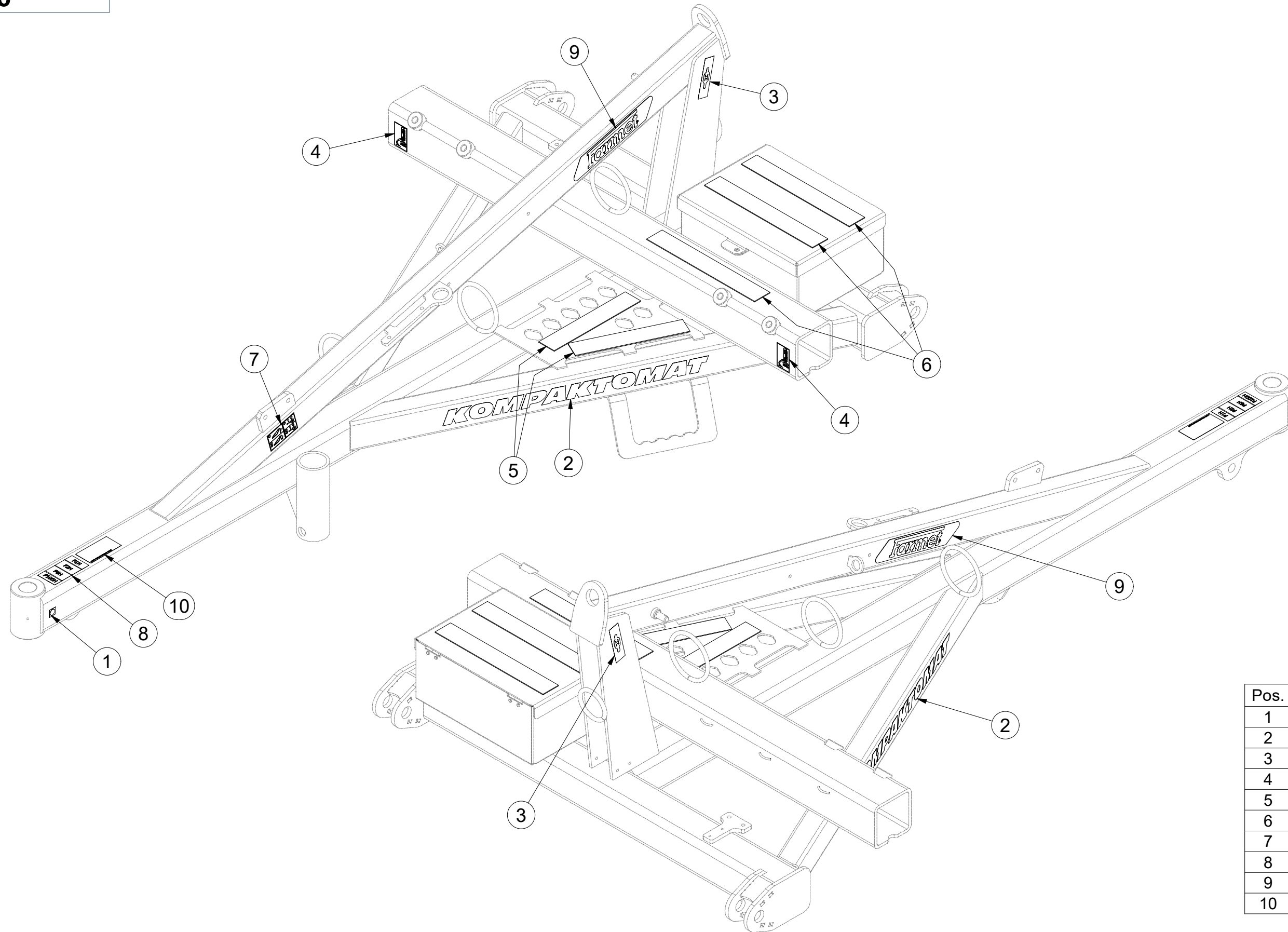

Pos.	Part Number	Pcs.
1	m03320	1
2	m07688	2
3	m03316	2
4	m10180	2
5	m11147	2
6	m11146	3
7	m11291	1
8	m11295	1
9	m13116	2
10	m13708	1

Ⓒ SADA ČEPŮ TBZ 3

Ⓓ BOLZENSATZ TBZ 3

Ⓕ KIT D'EMBOUITS TBZ 3

3011605

Ⓖ SET OF TBZ 3 PINS

Ⓡ КОМПЛЕКТ ПАЛЬЦЕВ TBZ 3

Ⓟ ZESTAW CZOPÓW TBZ 3

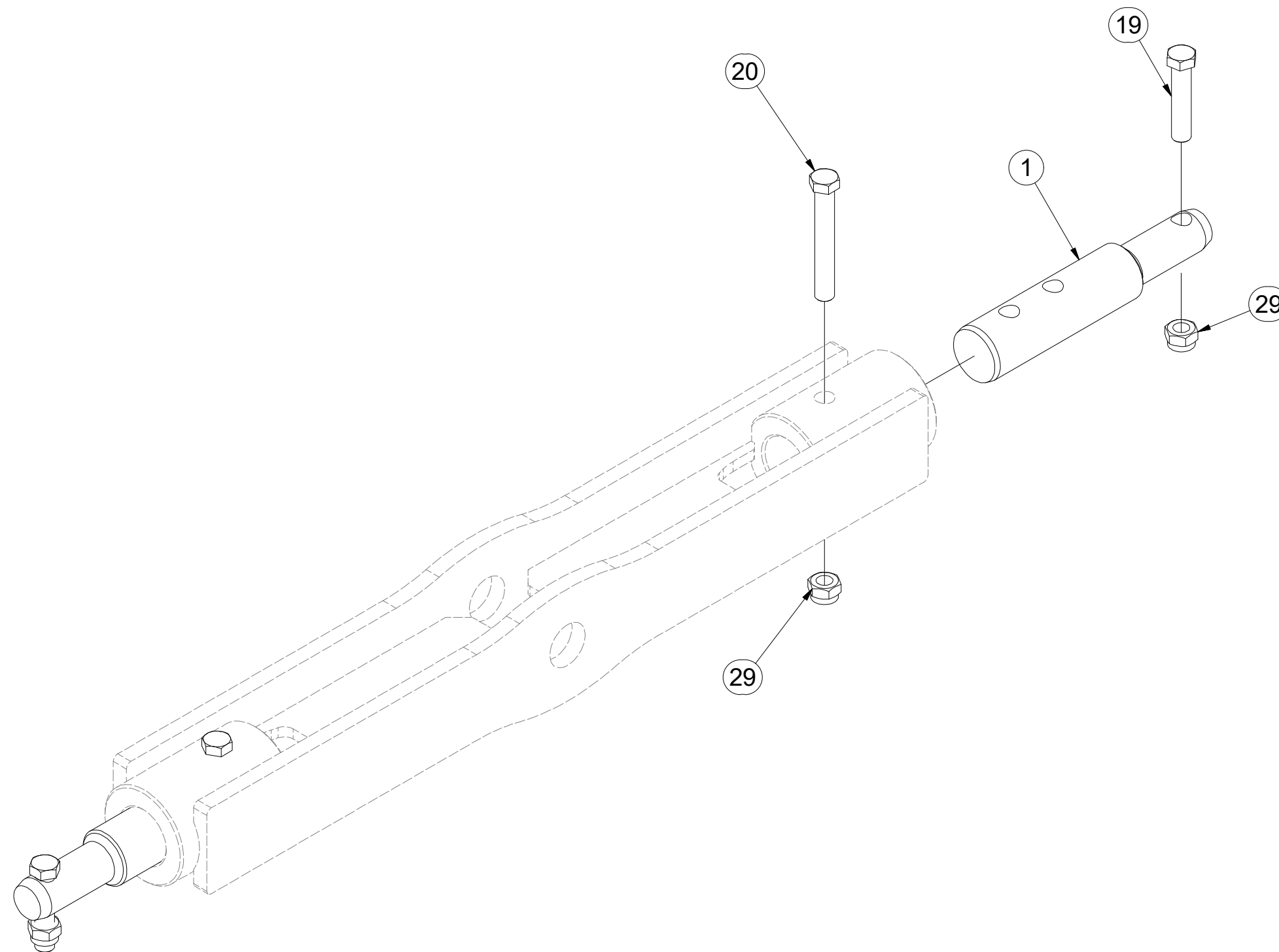

Pos.	Part Number	Pcs.
1	VZ00022884	2
19	m01133	2
20	m02970	2
29	m03683	4

ⒸZ TERČ PŘEDNÍ LEVÝ

Ⓓ SCHILD, VORDERES, LINKES

Ⓕ CIBLE AVANT GAUCHE

ⒸB LEFT FRONT DISC

ⒶЩИТОК ПЕРЕДНИЙ ЛЕВЫЙ

Ⓐ TARCZA PRZEDNIA LEWA



VZ00024252

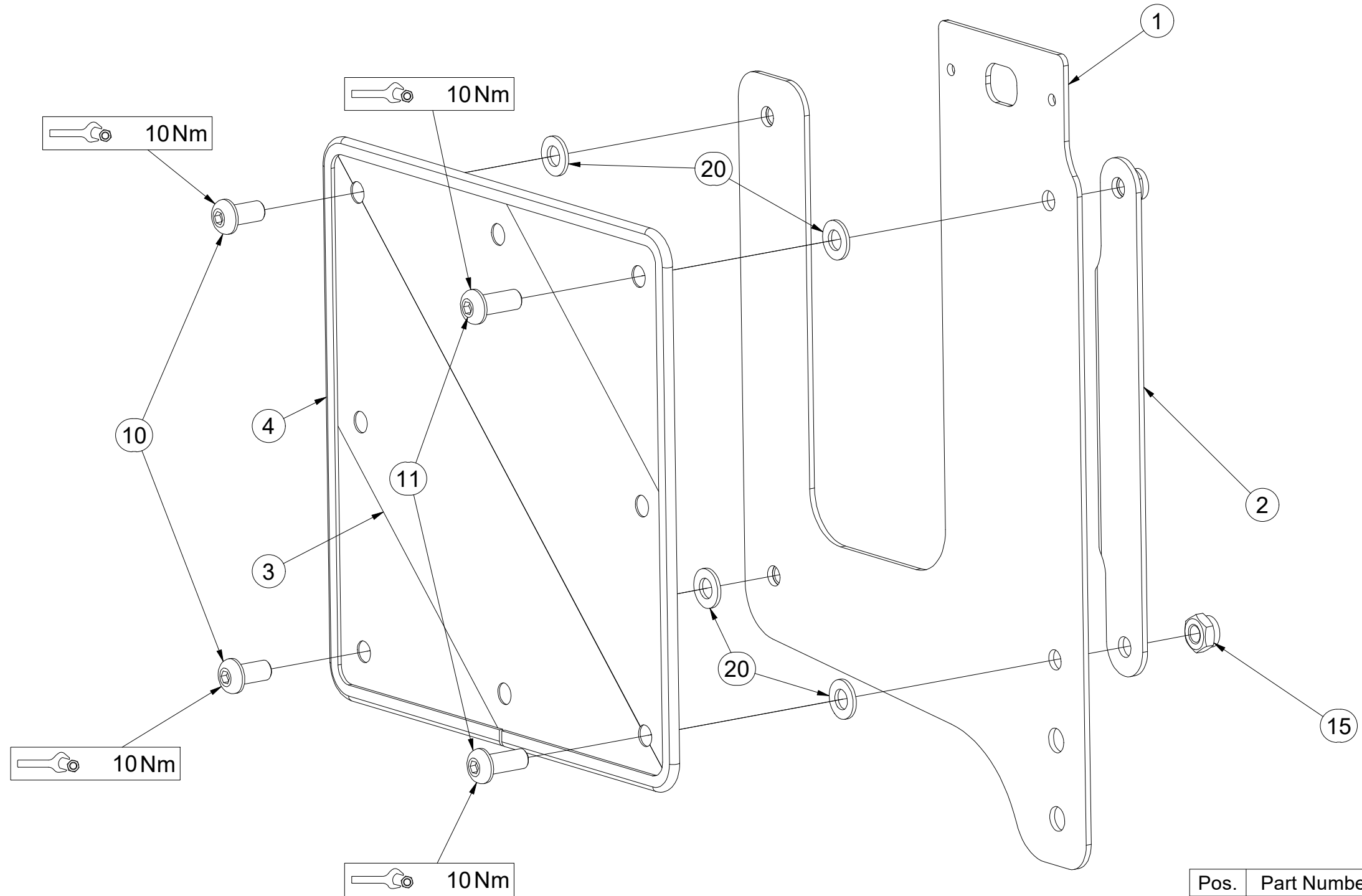
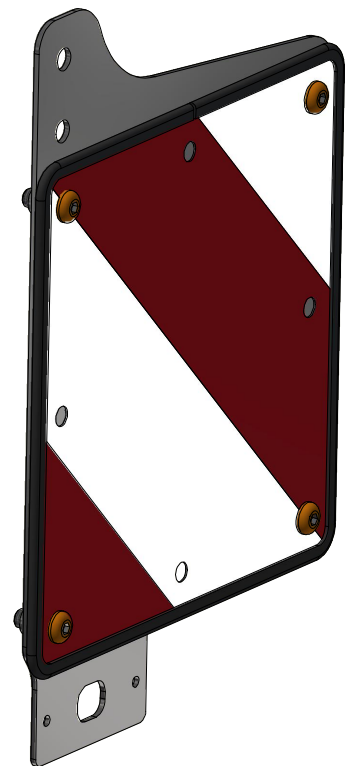

Pos.	Part Number	Pcs.
1	VZ00024254	1
2	VZ00024261	1
3	m18855	1
4	9005707	1
10	m16637	2
11	m16688	2
15	m03775	4
20	m01209	4

ⒸZ TERČ PŘEDNÍ PRAVÝ

Ⓓ SCHILD, VORDERES, RECHTES

Ⓕ CIBLE AVANT DROITE

ⒸB RIGHT FRONT DISC

ⒸU ЩИТОК ПЕРЕДНИЙ ПРАВЫЙ

ⒸL TARCZA PRZEDNIA PRAWA



VZ00024253

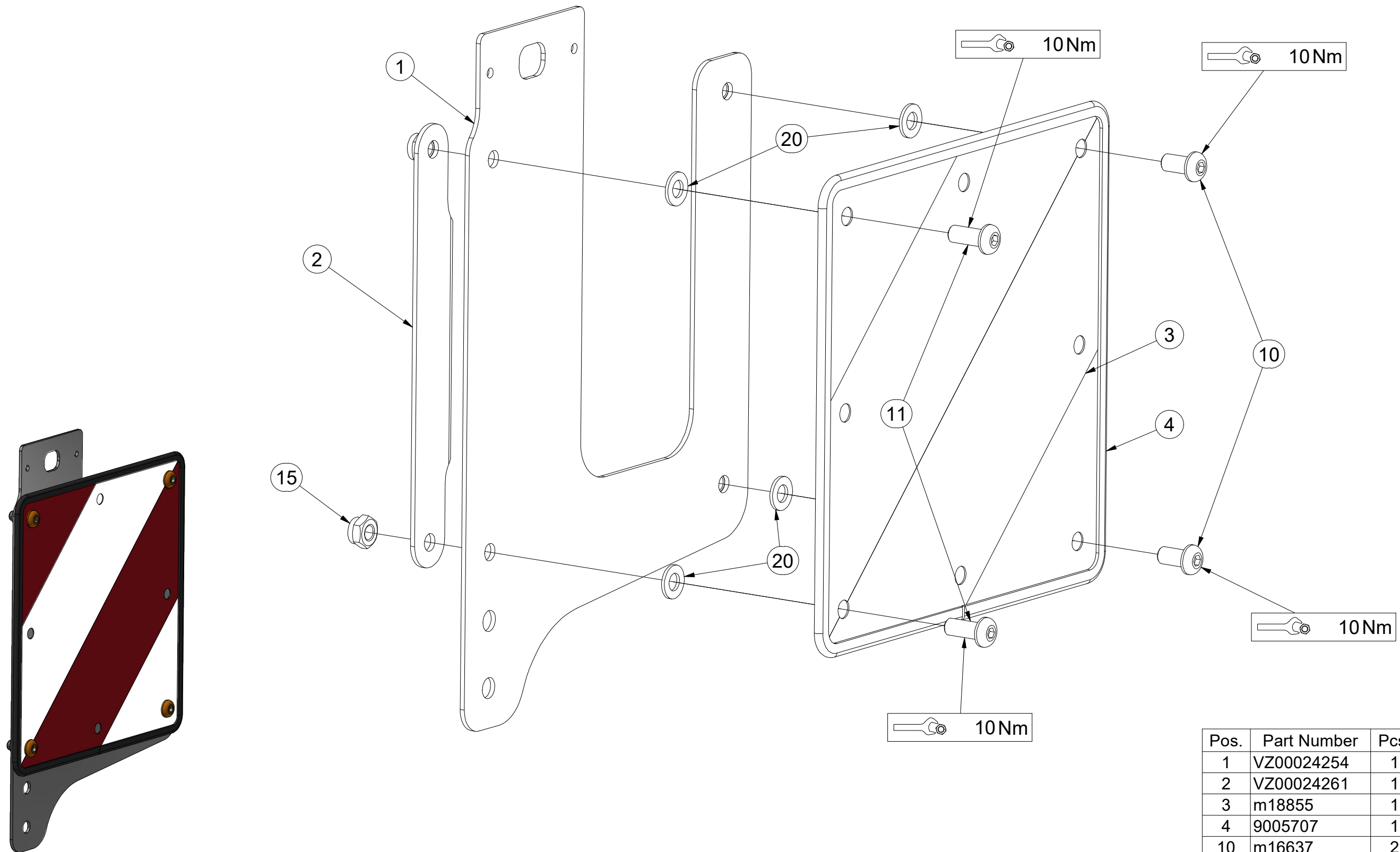

Pos.	Part Number	Pcs.
1	VZ00024254	1
2	VZ00024261	1
3	m18855	1
4	9005707	1
10	m16637	2
11	m16688	2
15	m03775	4
20	m01209	4

Ⓒ SADA KYPŘIČŮ STOP

Ⓓ SPURENLOCKERERSATZ

Ⓕ KIT DE CULTIVATEURS DE TRACES

3005535

Ⓖ SET OF TRACK CULTIVATORS

Ⓡ КОМПЛЕКТ РЫХЛИТЕЛЕЙ КОЛЕИ

Ⓟ ZESTAW SPULCHNIACZY ŚLADÓW

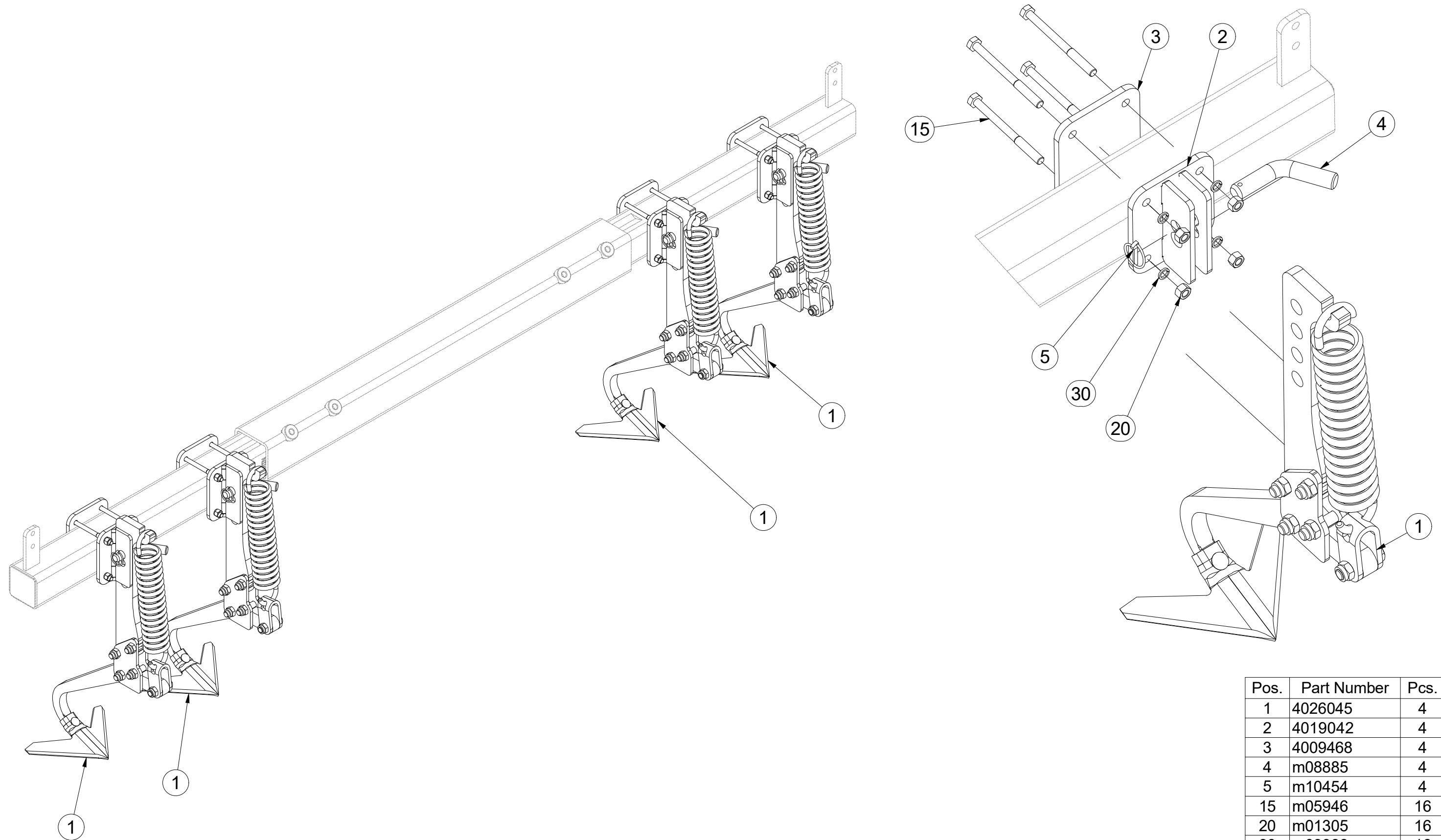

Pos.	Part Number	Pcs.
1	4026045	4
2	4019042	4
3	4009468	4
4	m08885	4
5	m10454	4
15	m05946	16
20	m01305	16
30	m03988	16

Ⓒ KYPŘIČ STOP

Ⓓ SPURENLOCKERER

Ⓕ CULTIVATEUR DES TRACES

Ⓖ TRACK CULTIVATOR

Ⓡ РЫХЛИТЕЛЬ КОЛЕИ

Ⓟ SPULCHNIARKA STÓP

Farmet

4026045

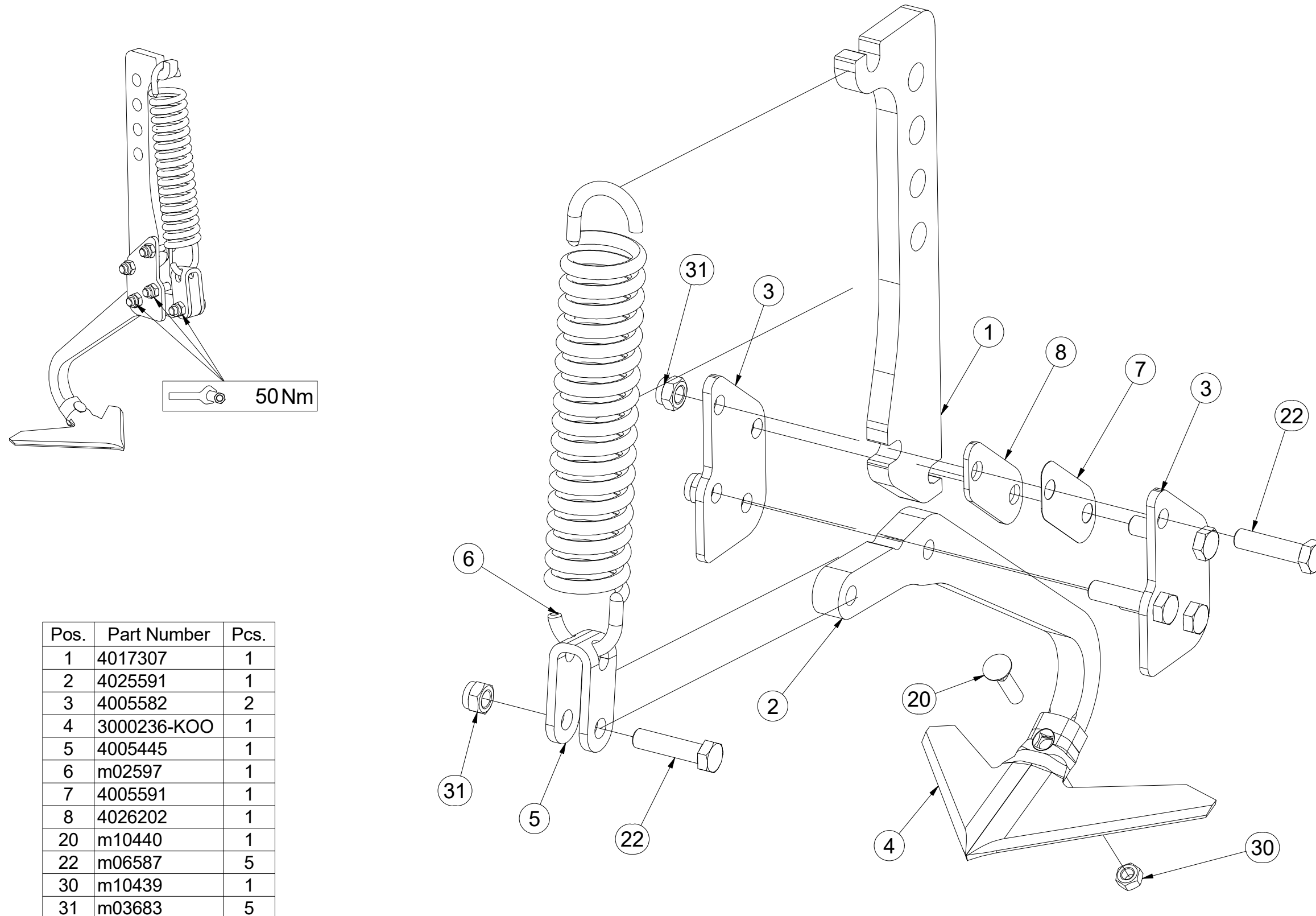

ⒸZ SADA PŘEDNÍCH SMYKŮ

Ⓓ SATZ VORDERE ACKERSCHLEPPEN

Ⓕ KIT DE NIVELEURS AVANT

3006127

ⒸGB SET OF FRONT LEVELLING BARS

ⒸRU КОМПЛЕКТ ПЕРЕДНИХ БОРОН

ⒸPL ZESTAW PRZEDNICH WŁÓK

Farmet

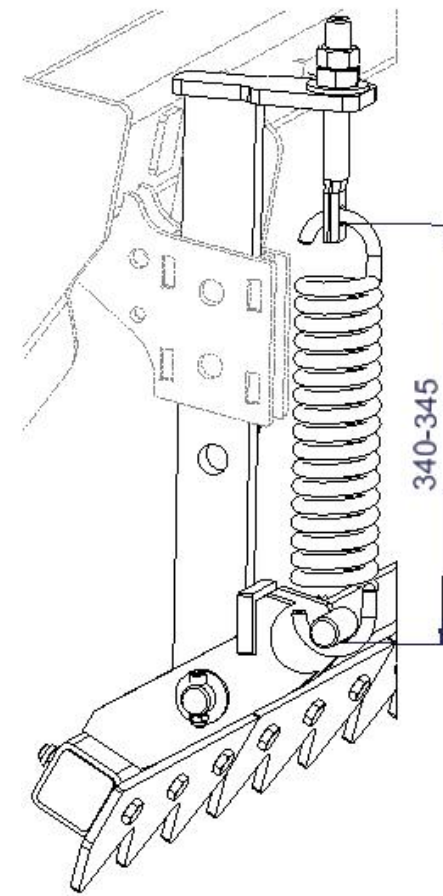
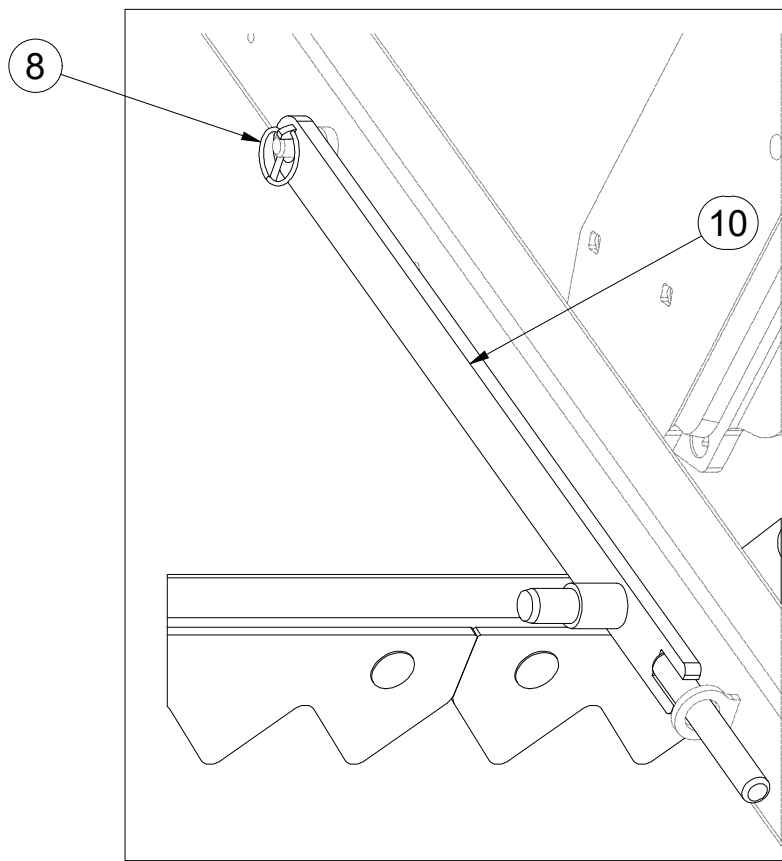
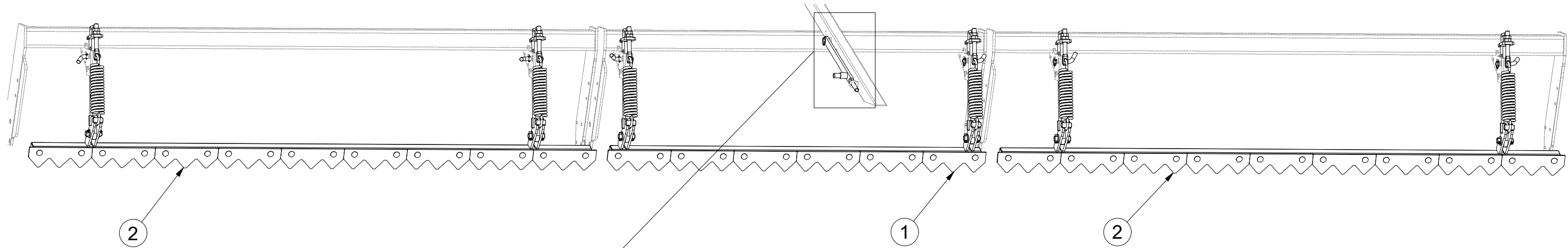

Pos.	Part Number	Pcs.
1	VZ00003364	1
2	VZ00003369	2
8	m10454	7
10	4006829	1

Ⓒ SADA PŘEDNÍCH SMYKŮ

Ⓓ SATZ VORDERE ACKERSCHLEPPEN

Ⓕ KIT DE NIVELEURS AVANT

Ⓖ SET OF FRONT LEVELLING BARS

Ⓡ КОМПЛЕКТ ПЕРЕДНИХ БОРОН

Ⓟ ZESTAW PRZEDNICH WŁÓK



3006127

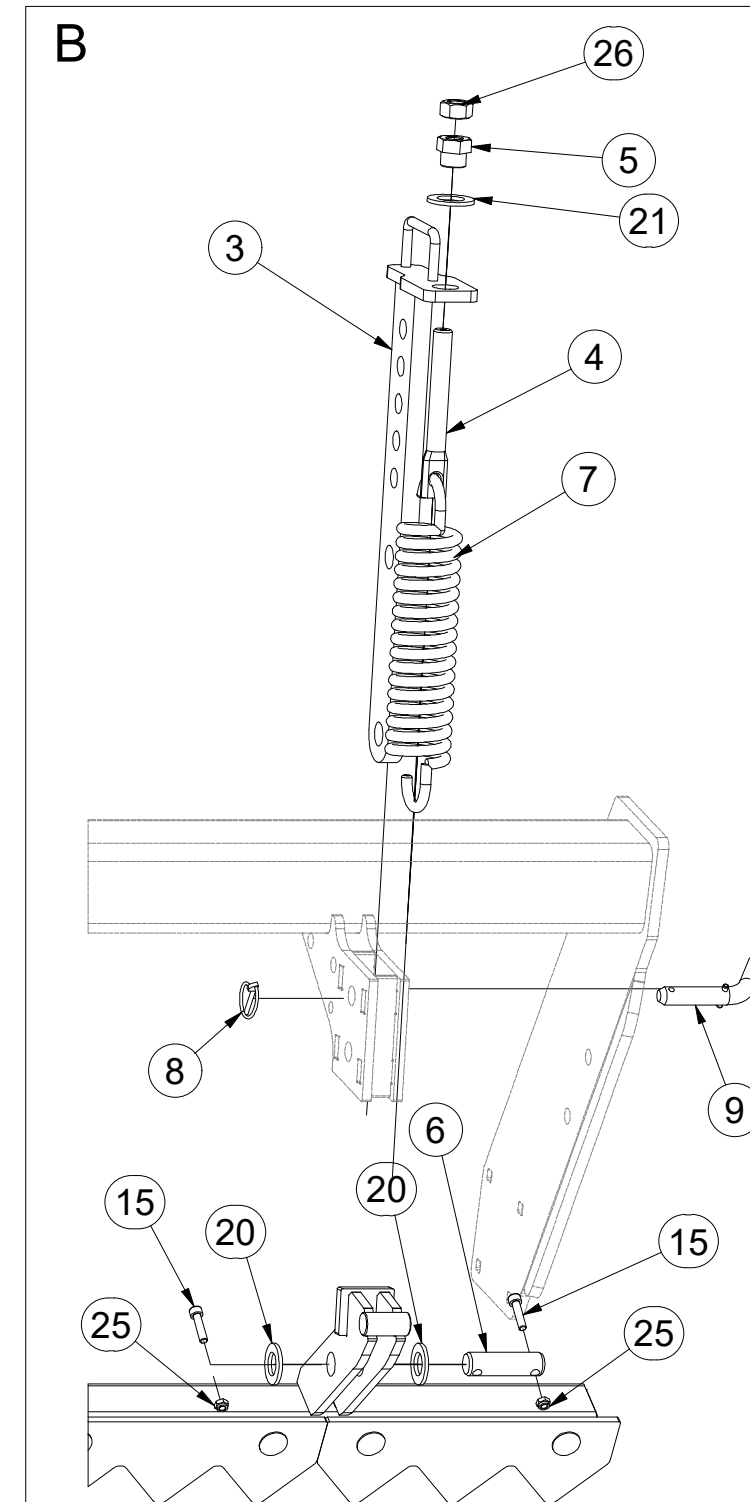
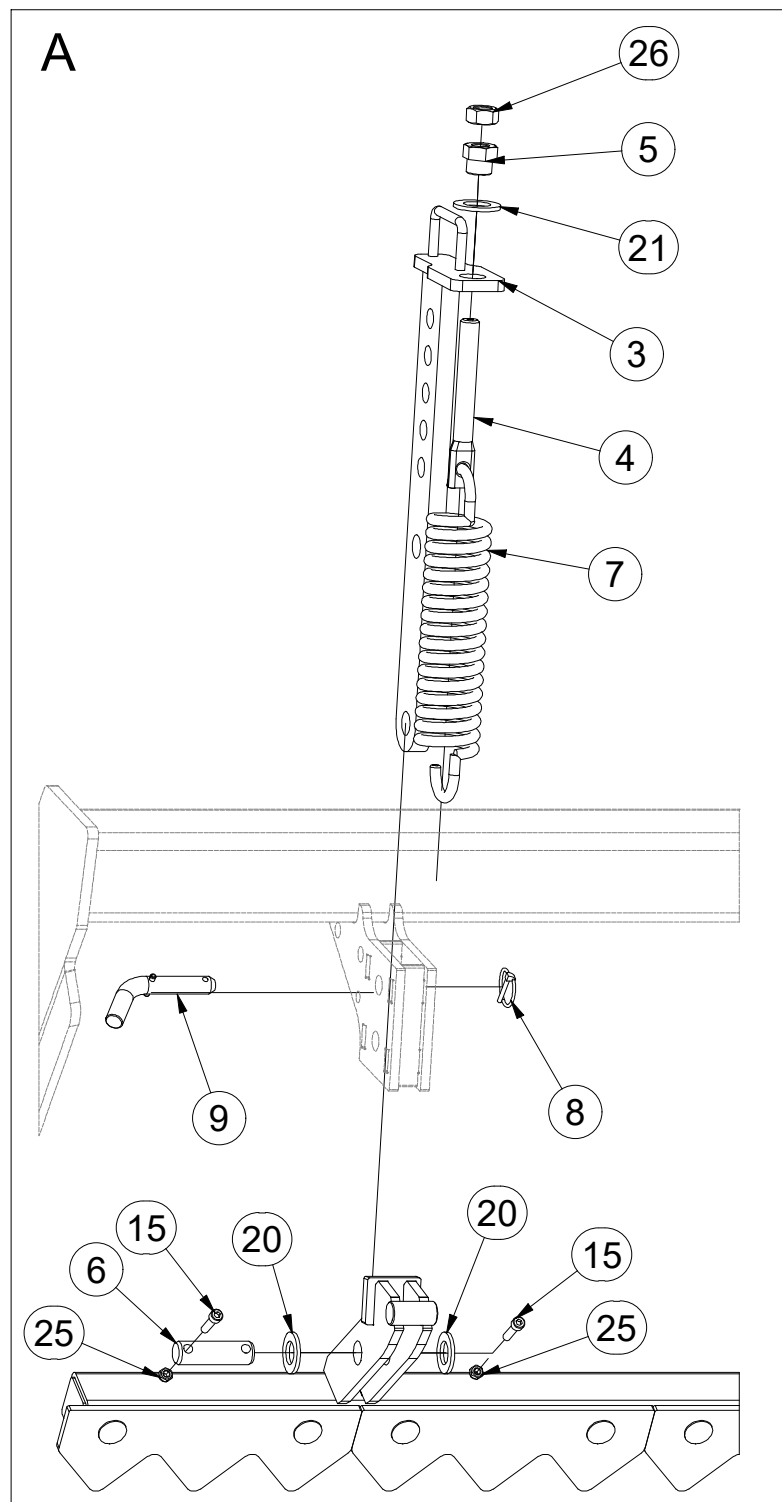
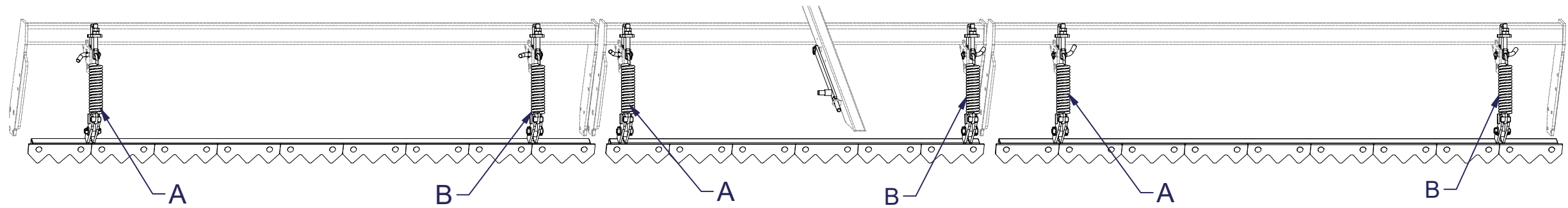

Pos.	Part Number	Pcs.
3	3008686	6
4	4003401	6
5	4000189	6
6	4010390	6
7	m02597	6
8	m10454	7
9	4012011	6
15	m09464	12
20	m14028	12
21	m01225	6
25	m04503	12
26	m01307	6

Ⓒ PŘEDNÍ SMYK

Ⓓ VORDERE ACKERSCHLEIFE

Ⓕ NIVELEUR AVANT

Ⓖ FRONT DRAG

Ⓡ ПЕРЕДНЯЯ БОРОНА

Ⓟ PRZEDNIA WŁÓKA

Farmet

VZ00003364

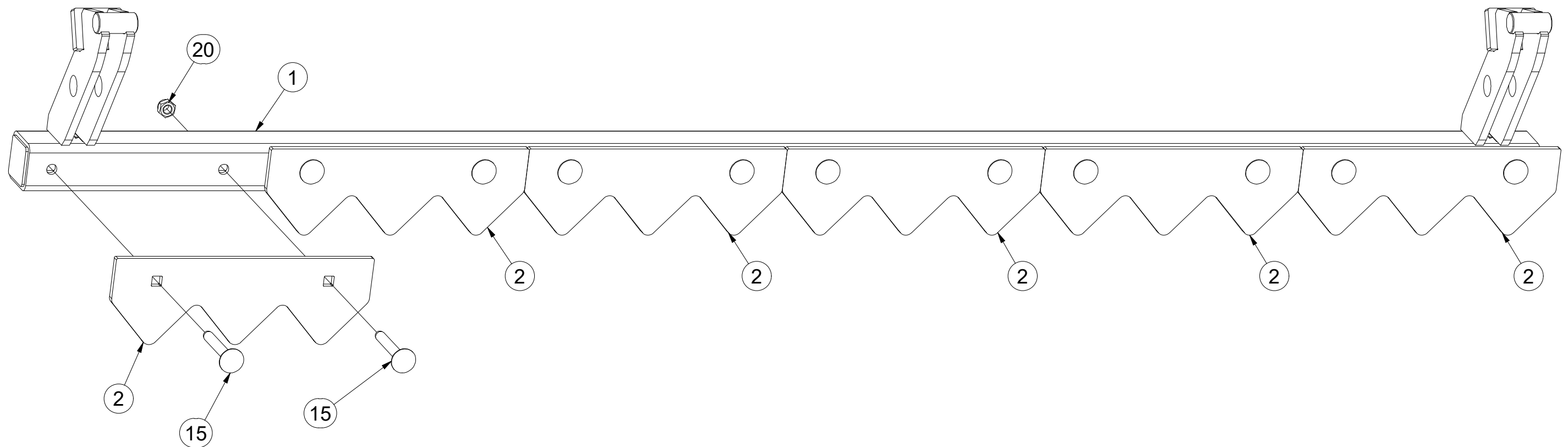
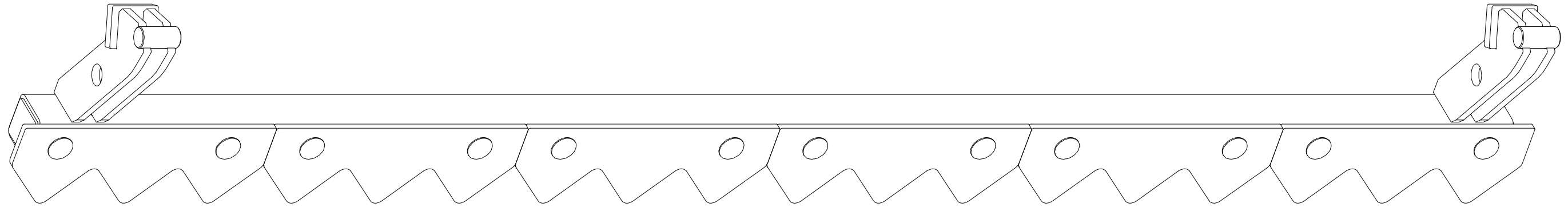

Pos.	Part Number	Pcs.
1	VZ00003365	1
2	VZ00003366	6
15	m08339	12
20	m04301	12

Ⓒ PŘEDNÍ SMYK

Ⓓ VORDERE ACKERSCHLEIFE

Ⓕ NIVELEUR AVANT

Ⓒ FRONT DRAG

Ⓓ ПЕРЕДНЯЯ БОРОНА

Ⓕ PRZEDNIA WŁÓKA

Farmet

VZ00003369

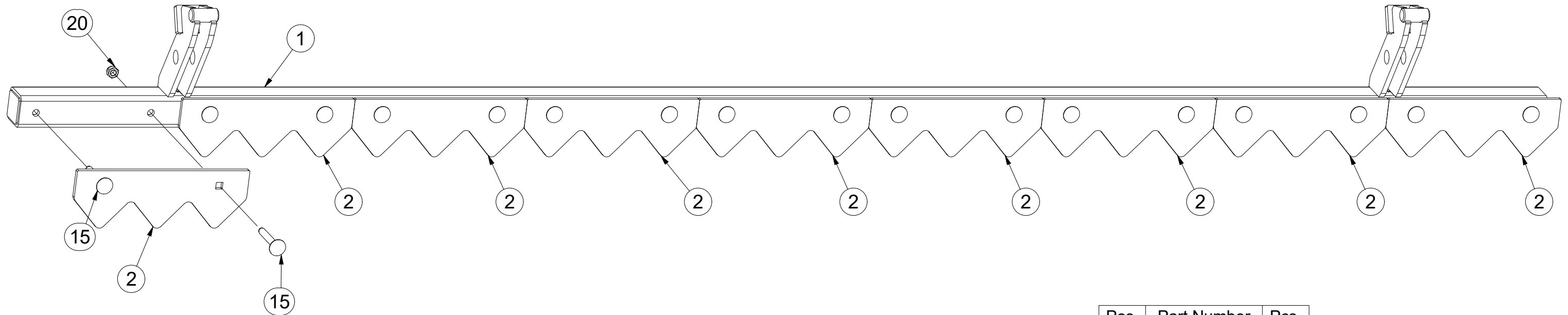
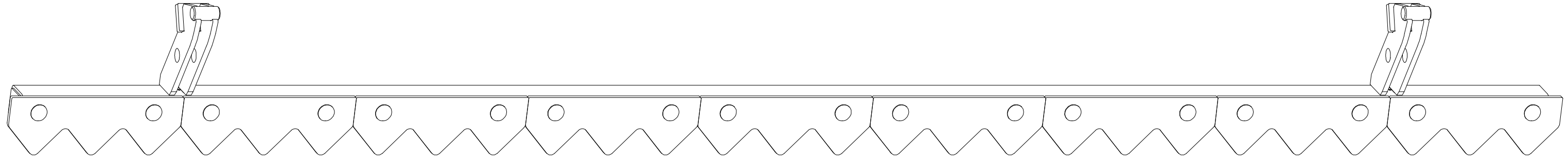

Pos.	Part Number	Pcs.
1	VZ00003370	1
2	VZ00003366	9
15	m08339	18
20	m04301	18

Ⓒ SMYKY ZADNÍCH VÁLCŮ

Ⓓ SCHLEIFE HINTERE WALZE

Ⓕ NIVELEUR ARRIÈRE ROULEAUX

VZ00019831

Ⓖ DRAG REAR ROLLERS

Ⓡ ПЛАНКИ ЗАДНИХ КАТКОВ

Ⓟ WŁÓKY TYLNYCH WAŁOW

Farmet

Pos.	Part Number	Pcs.
1	VZ00019830	1
2	VZ00014941	1
10	m04343	2
15	m04301	2

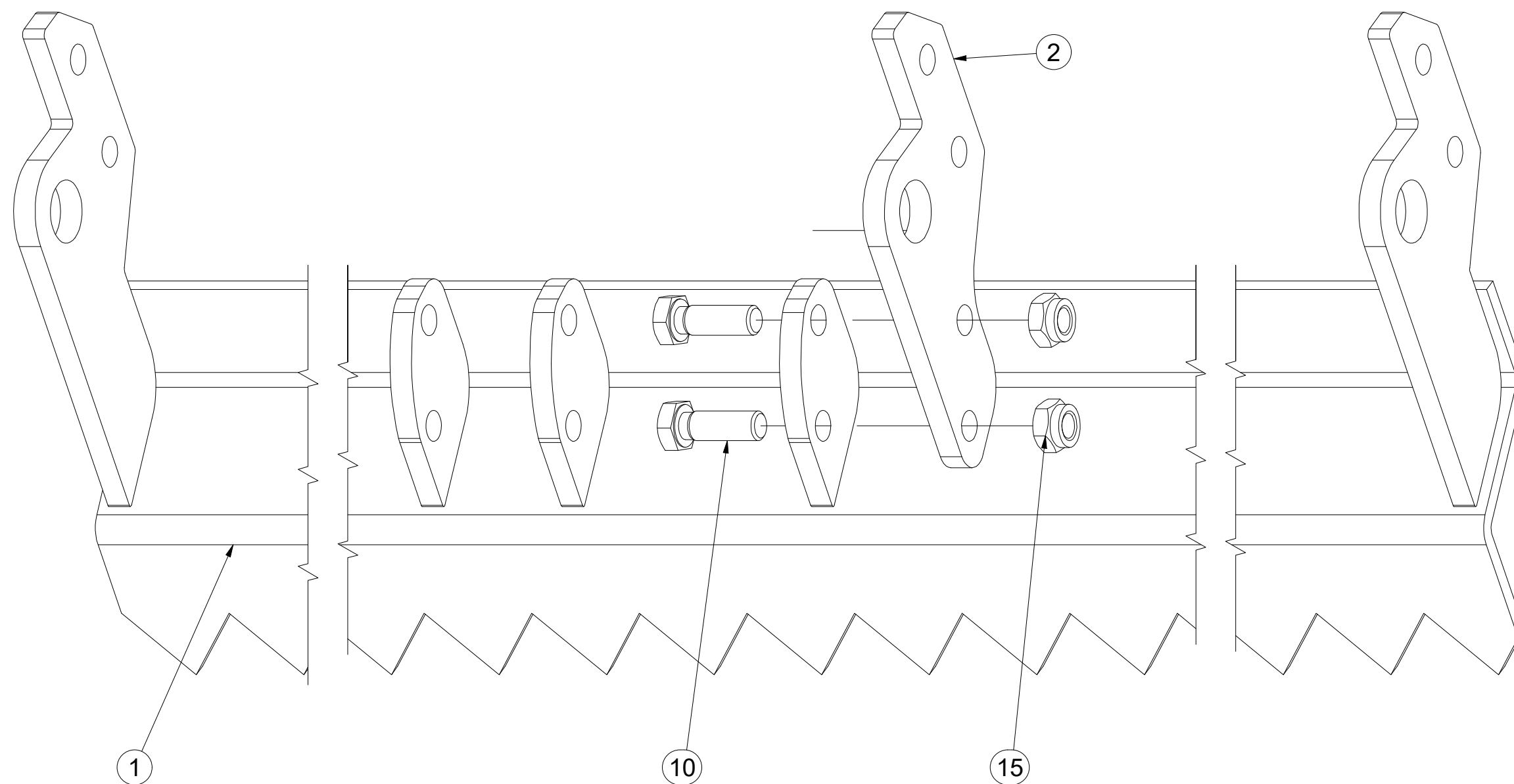

CZ SADA PŘEDNÍCH VÁLCŮ
 D SATZ VORDERE WALZEN
 F KIT DE ROULEAUX AVANT

GB SET OF FRONT ROLLERS
 RU КОМПЛЕКТ ПЕРЕДНИХ КАТКОВ
 PL ZESTAW PRZEDNICH WAŁÓW

Farmet

3011904

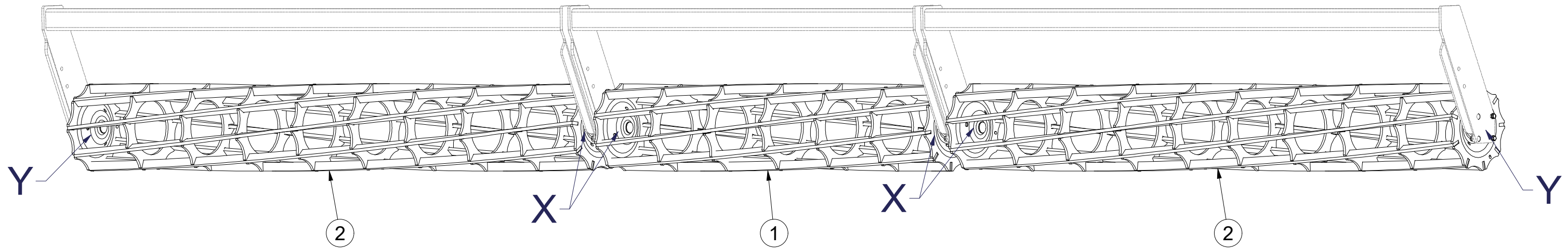

Y

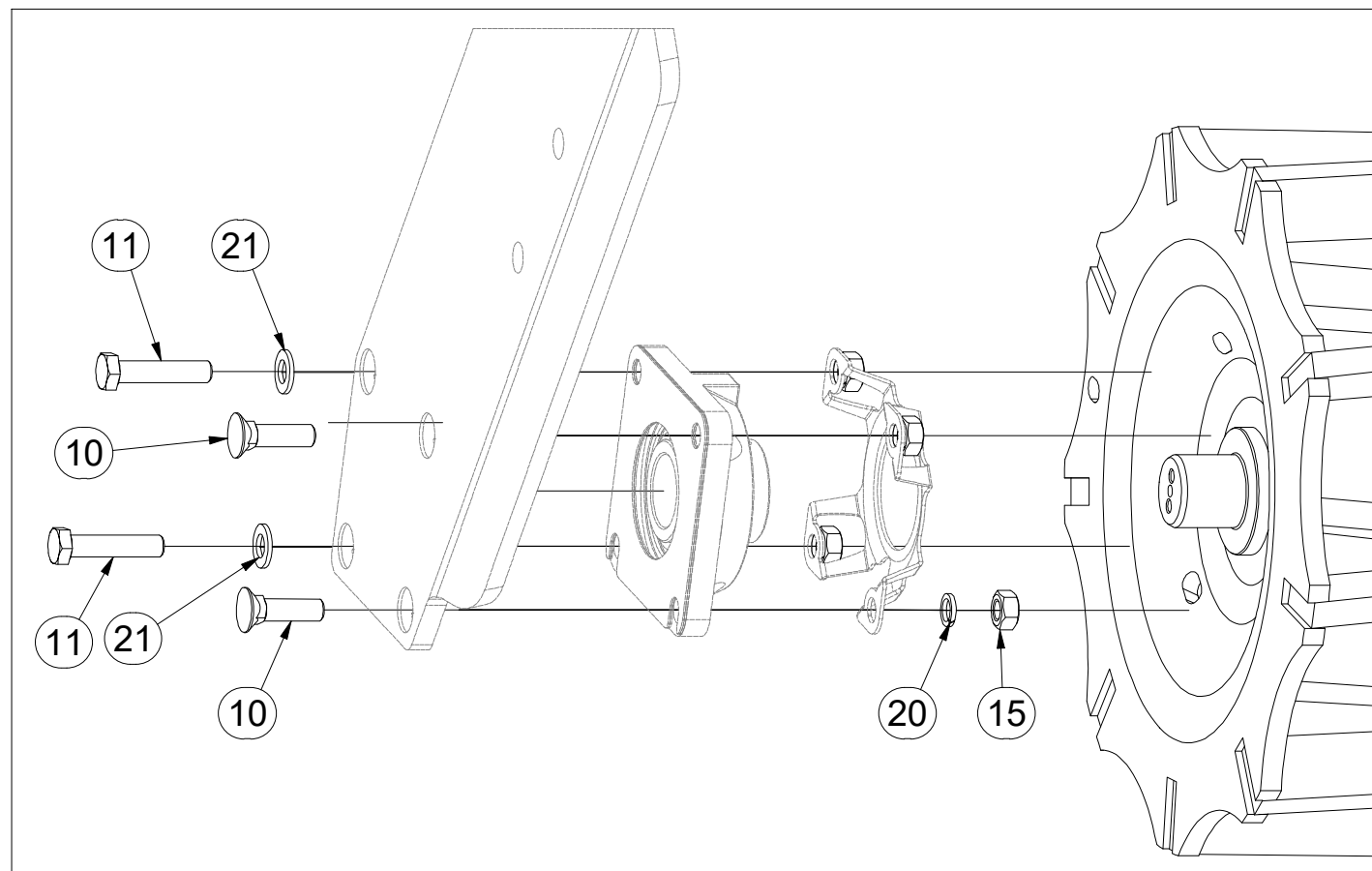

X

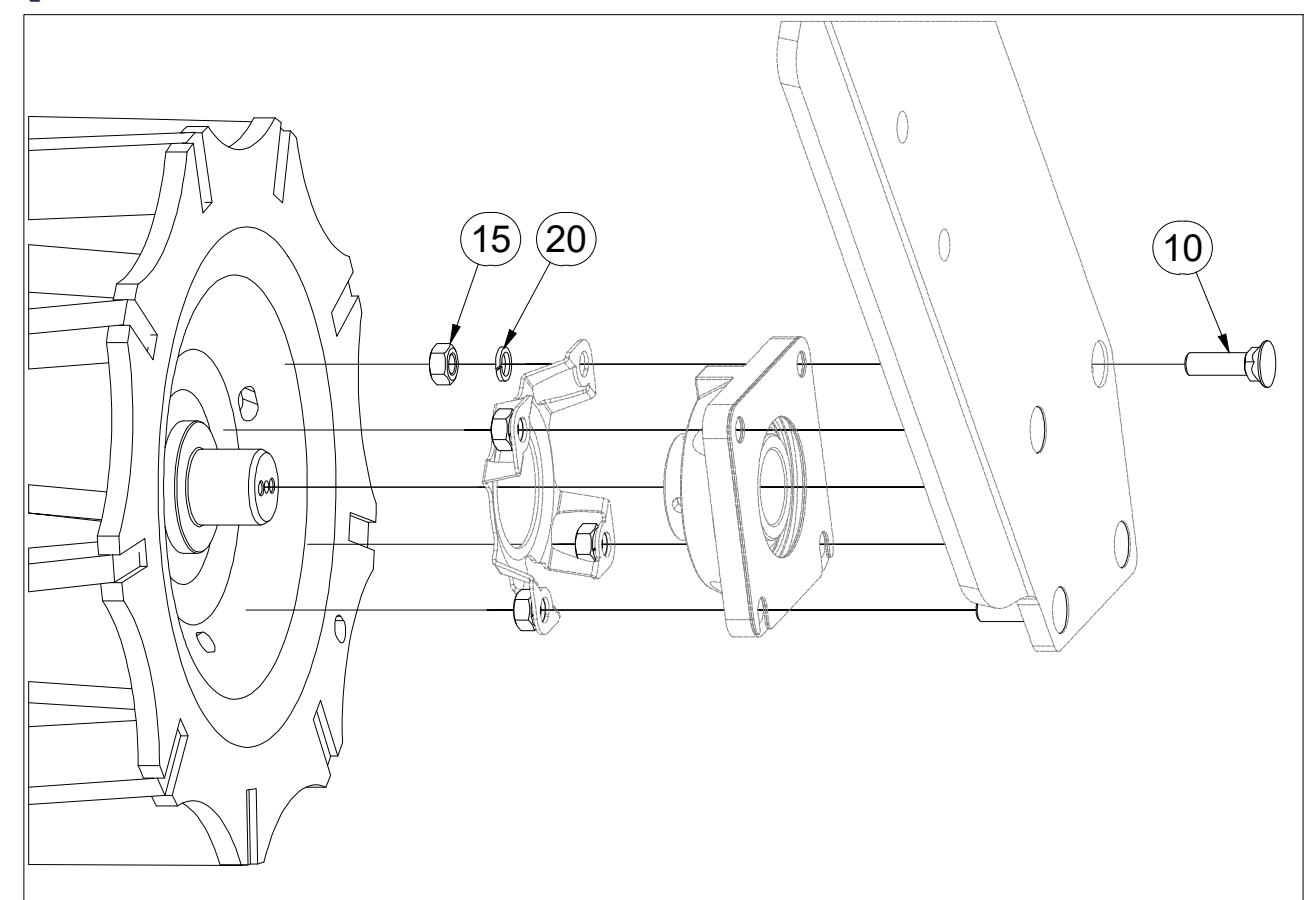

Pos.	Part Number	Pcs.	Pos.	Part Number	Pcs.
1	2000679	1	15	m01305	24
2	2001151	2	20	m03988	24
10	m03519	20	21	m17741	4
11	m04412	4			

- ⒸZ SADA LOŽISEK
- Ⓓ SATZ LAGER
- Ⓕ KIT DE ROULEMENTS

- ⒼB SET OF BEARINGS
- ⒺU КОМПЛЕКТ ПОДШИПНИКОВ
- ⒼL ZESTAW ŁOŻYSK



VZ00012468

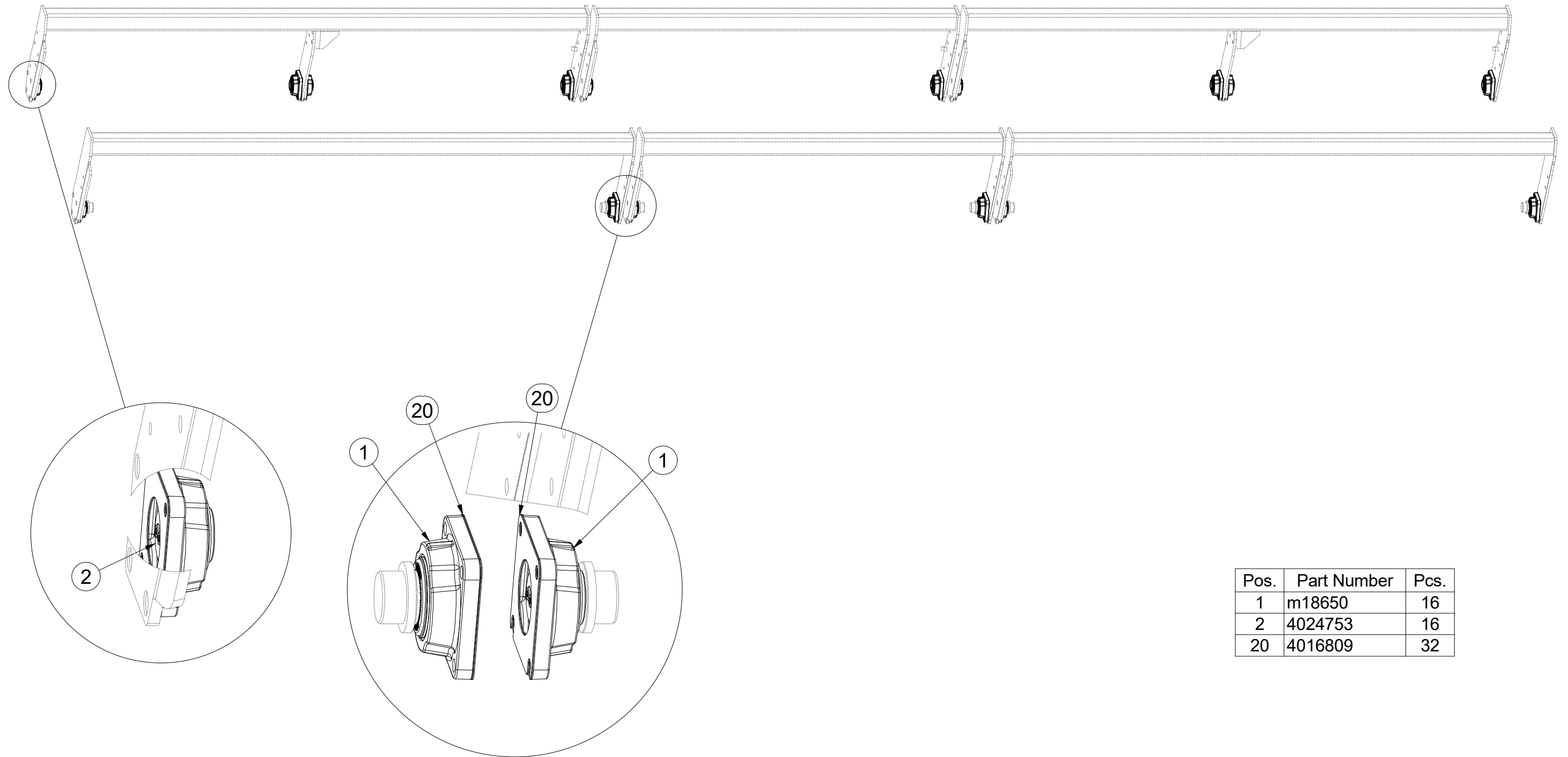

Pos.	Part Number	Pcs.
1	m18650	16
2	4024753	16
20	4016809	32

- Ⓒ SADA LOŽISEK
- Ⓓ SATZ LAGER
- Ⓕ KIT DE ROULEMENTS

- Ⓖ SET OF BEARINGS
- Ⓡ КОМПЛЕКТ ПОДШИПНИКОВ
- Ⓟ ZESTAW ŁOŻYSK



VZ00012468

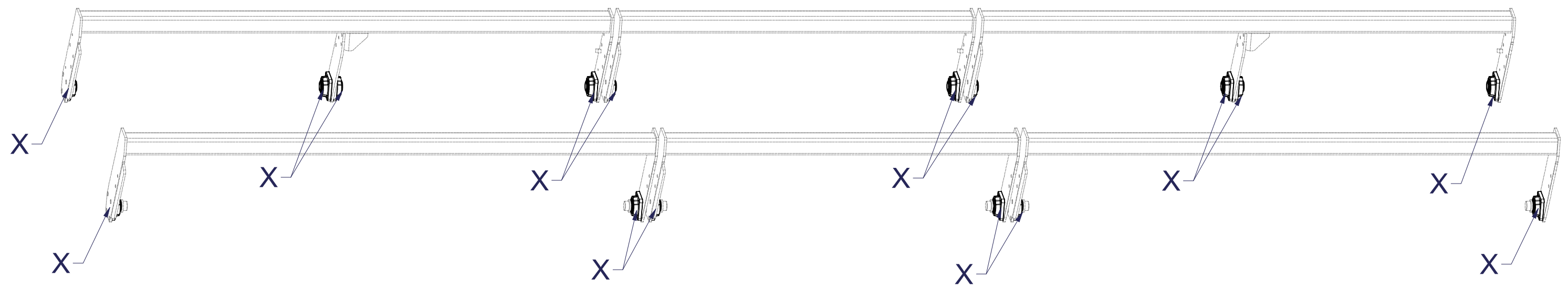

X

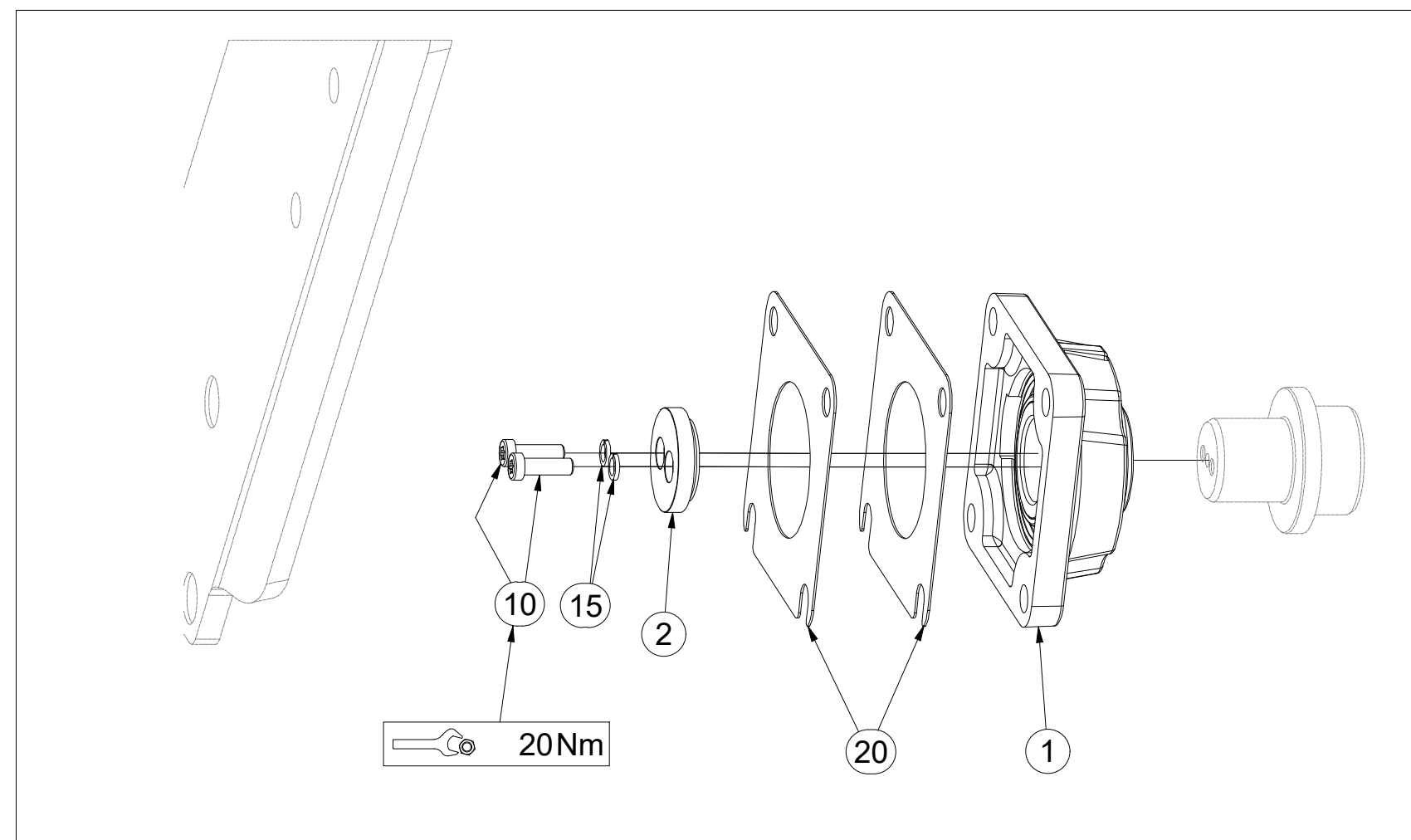

Pos.	Part Number	Pcs.
1	m18650	16
2	4024753	16
15	m01202	32
10	m18858	32
20	4016809	32

CZ SADA OVLÁDÁNÍ RADLICE
 D STEUERSATZ PFLUGSCHAREN
 F KIT DE COMMANDE DES SOCS

GB SET OF PLOUGHSHARE CONTROL
 RU КОМПЛЕКТ УПРАВЛЕНИЯ ЛАП
 PL ZESTAW STEROWANIA RADLICAMI



VZ00003341

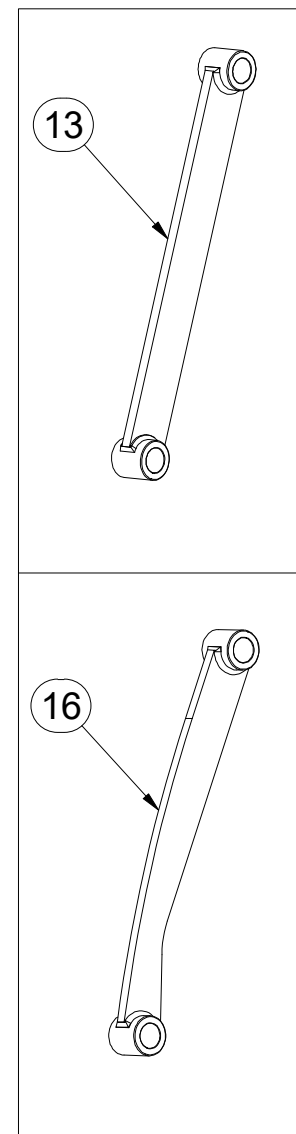
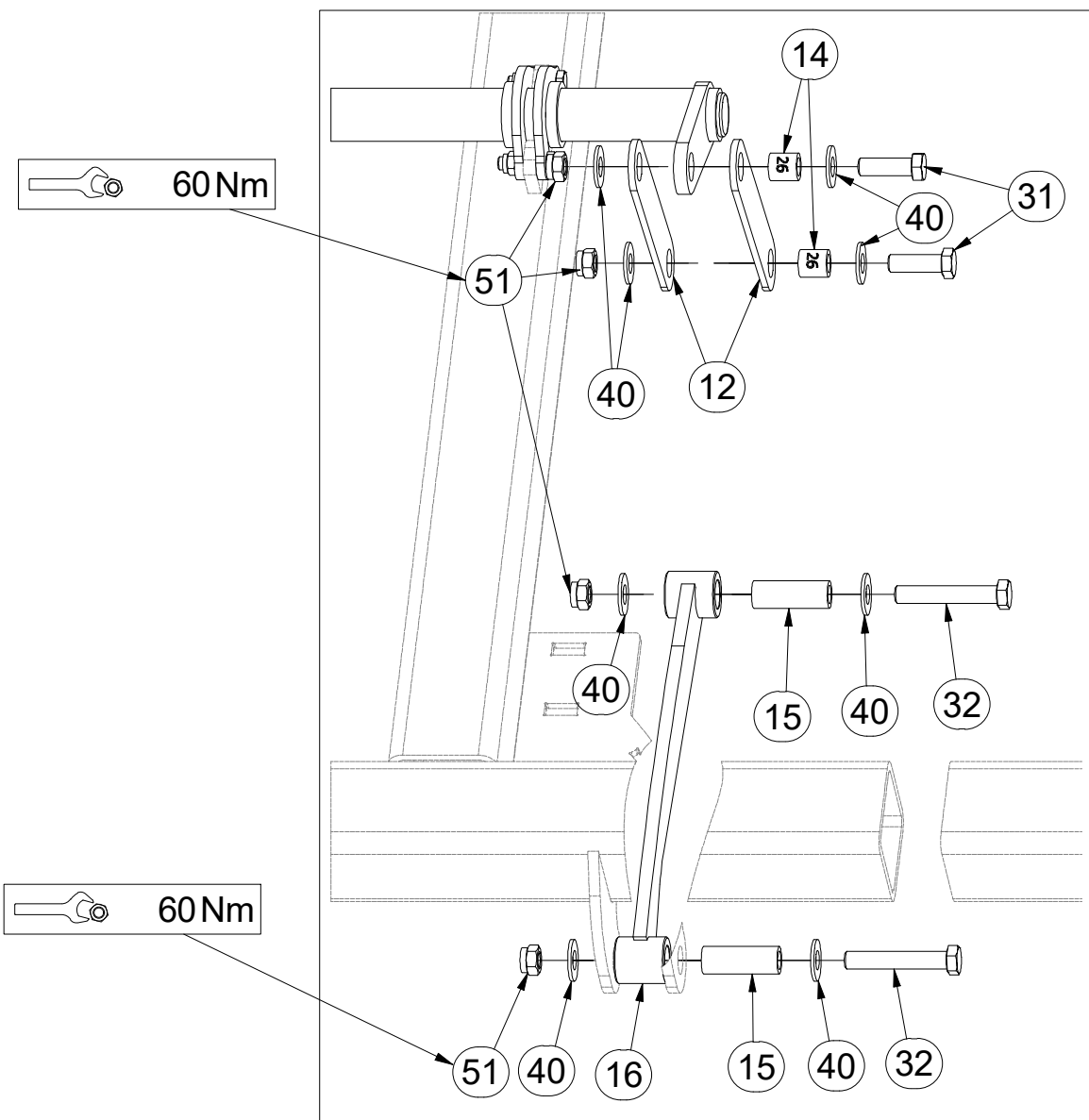
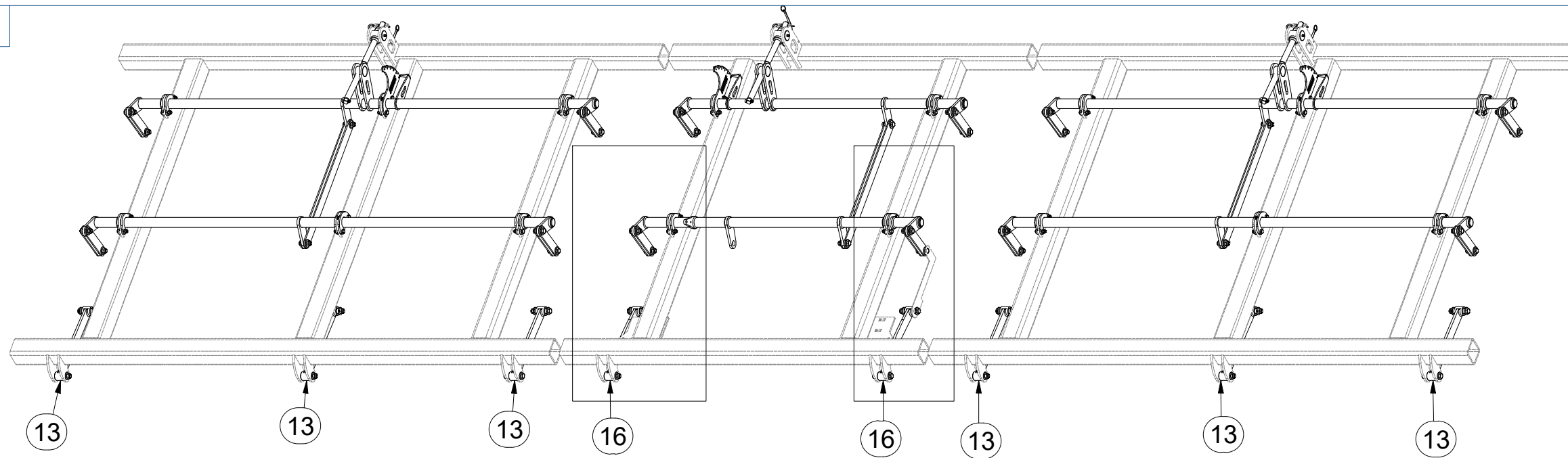

Pos.	Part Number	Pcs.
1	3002831	1
12	4005333	24
13	4003971	6
14	4002265	30
15	9001426	16
16	VZ00003342	2
31	m04355	30
32	m07673	16
40	m05651	92
51	m03683	46

- Ⓒ SADA OVLÁDÁNÍ RADLICE
- Ⓓ STEUERSATZ PFLUGSCHAREN
- Ⓕ KIT DE COMMANDE DES SOCS

- Ⓖ SET OF PLOUGHSHARE CONTROL
- Ⓔ КОМПЛЕКТ УПРАВЛЕНИЯ ЛАП
- Ⓗ ZESTAW STEROWANIA RADLICAMI



VZ00003341

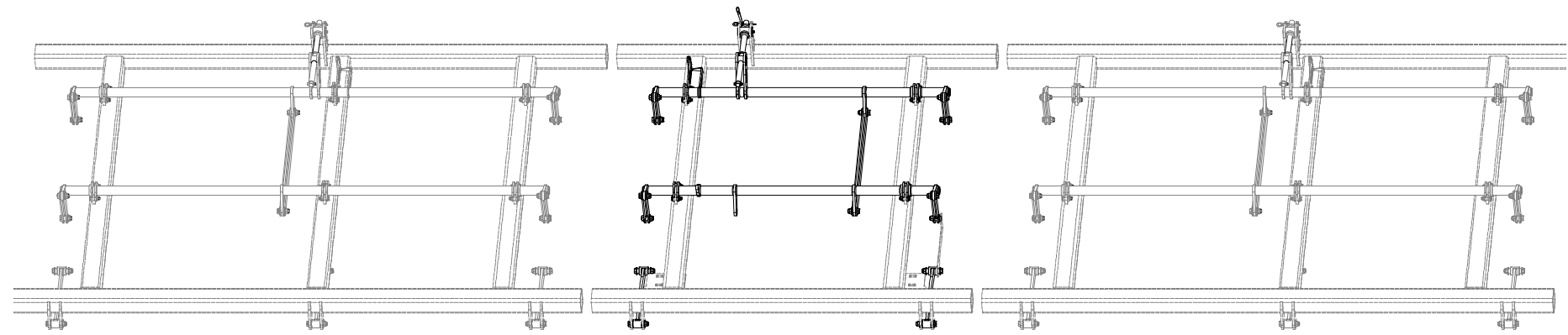
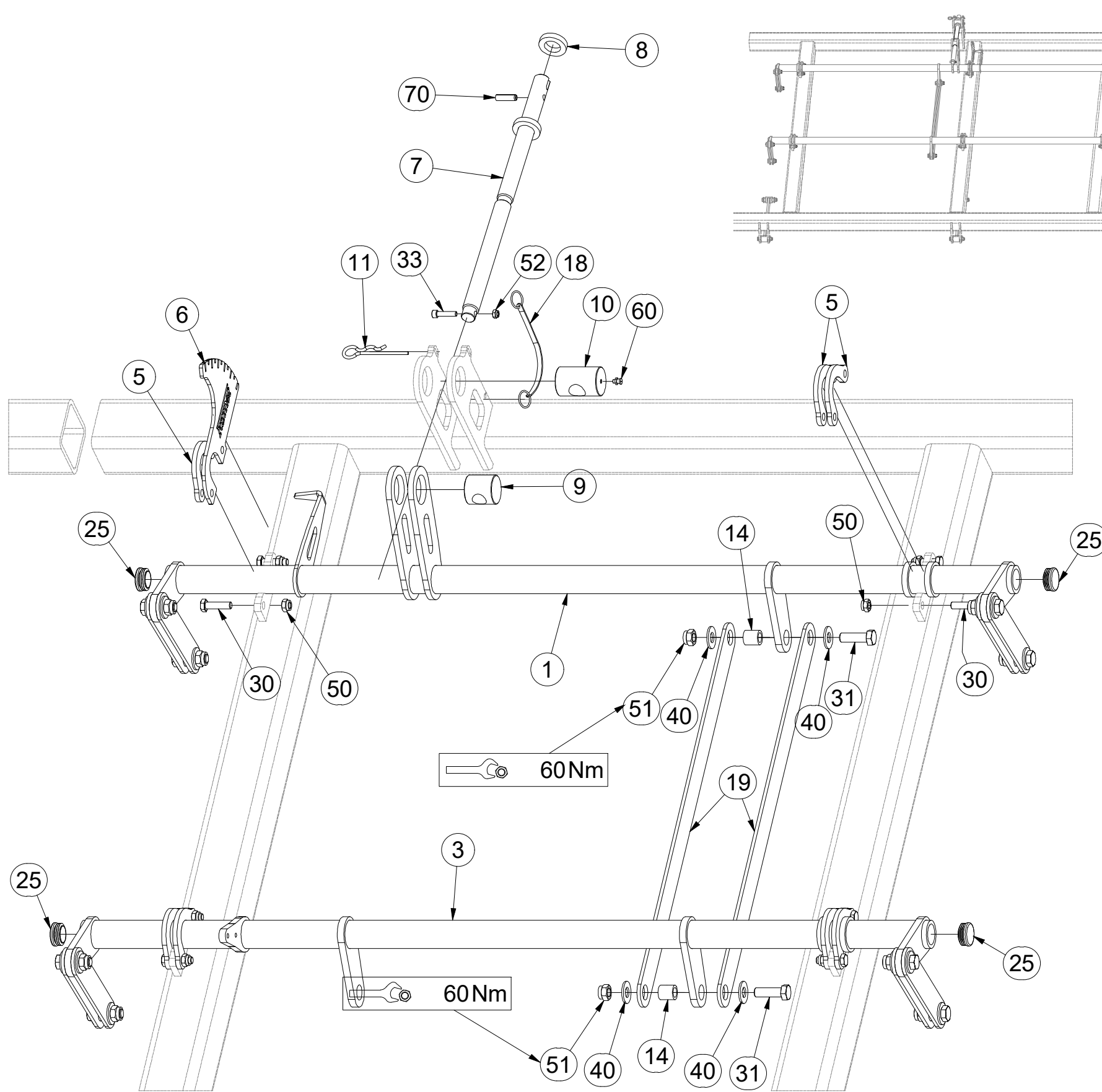

Pos.	Part Number	Pcs.
1	3002831	1
3	VZ00007199	1
5	4005332	23
6	4023896	3
7	4024250	3
8	9002560	3
9	4005340	3
10	9002114	3
11	m09988	3
14	4002265	30
18	m12467	3
19	4005334	6
25	m10130	12
30	m06077	32
31	m04355	30
33	m09464	3
40	m05651	92
50	m04301	32
51	m03683	46
52	m04503	3
60	m10451	3
70	m10736	3

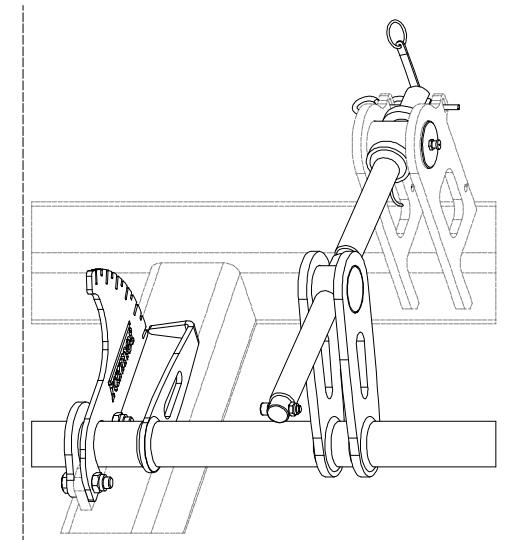

Ⓒ SADA OVLÁDÁNÍ RADLICE

Ⓓ STEUERSATZ PFLUGSCHAREN

Ⓕ KIT DE COMMANDE DES SOCS

Ⓖ SET OF PLOUGHSHARE CONTROL

Ⓡ КОМПЛЕКТ УПРАВЛЕНИЯ ЛАП

Ⓢ ZESTAW STEROWANIA RADLICAMI



VZ00003341

Pos.	Part Number	Pcs.	Pos.	Part Number	Pcs.
2	3002863	2	19	4005334	6
4	3002864	2	25	m10130	12
5	4005332	23	30	m06077	32
6	4023896	3	31	m04355	30
7	4024250	3	33	m09464	3
8	9002560	3	40	m05651	92
9	4005340	3	50	m04301	32
10	9002114	3	51	m03683	46
11	m09988	3	52	m04503	3
14	4002265	30	60	m10451	3
17	4022084	6	70	m10736	3
18	m12467	3			

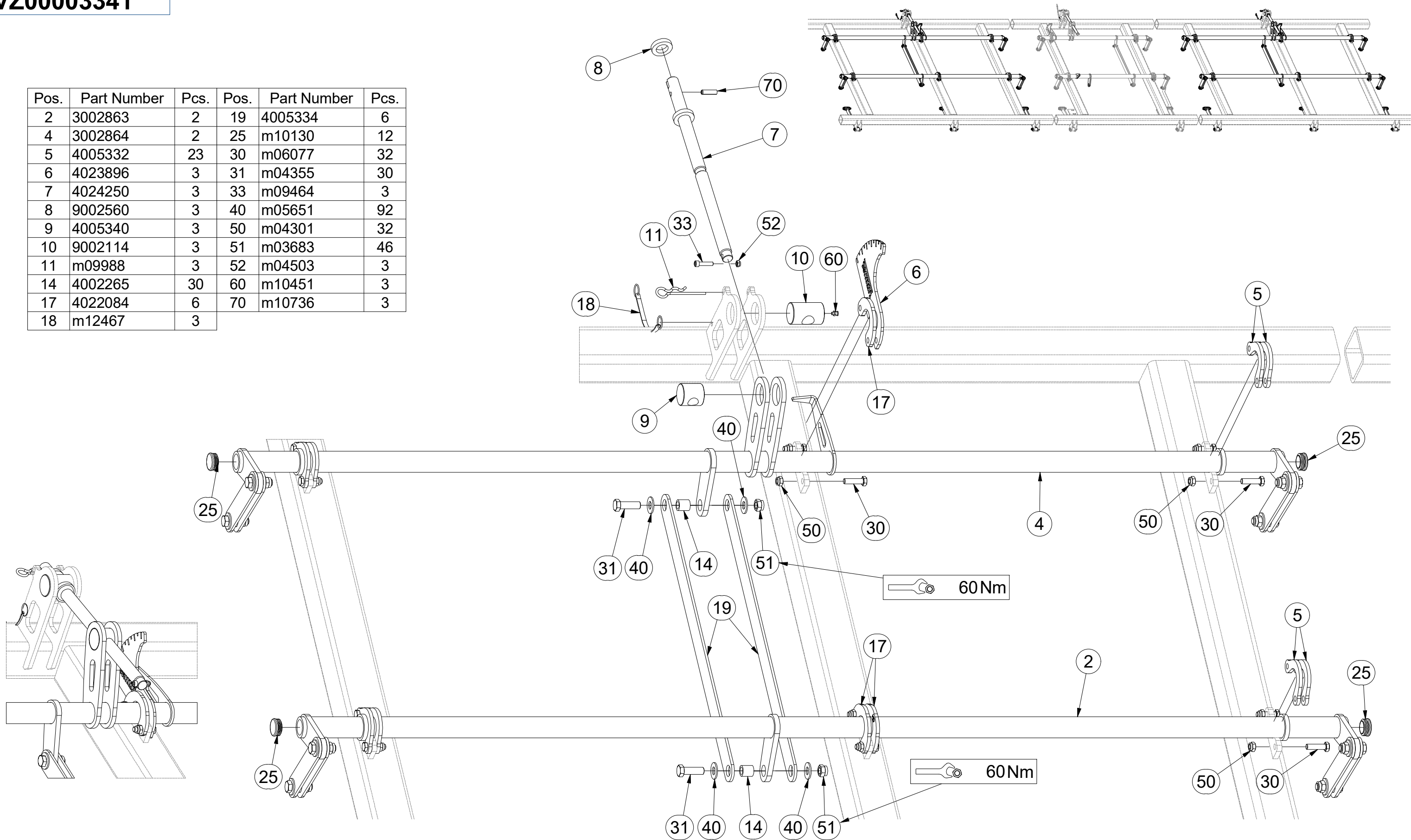

ⒸZ SADA RADLIC

Ⓓ SCHARSATZ

Ⓕ KIT DE SOCS

ⒸGB SET OF PLOUGHSHARES

ⒸRU КОМПЛЕКТ ЛАП

ⒸPL ZESTAW REDLIC



3012376

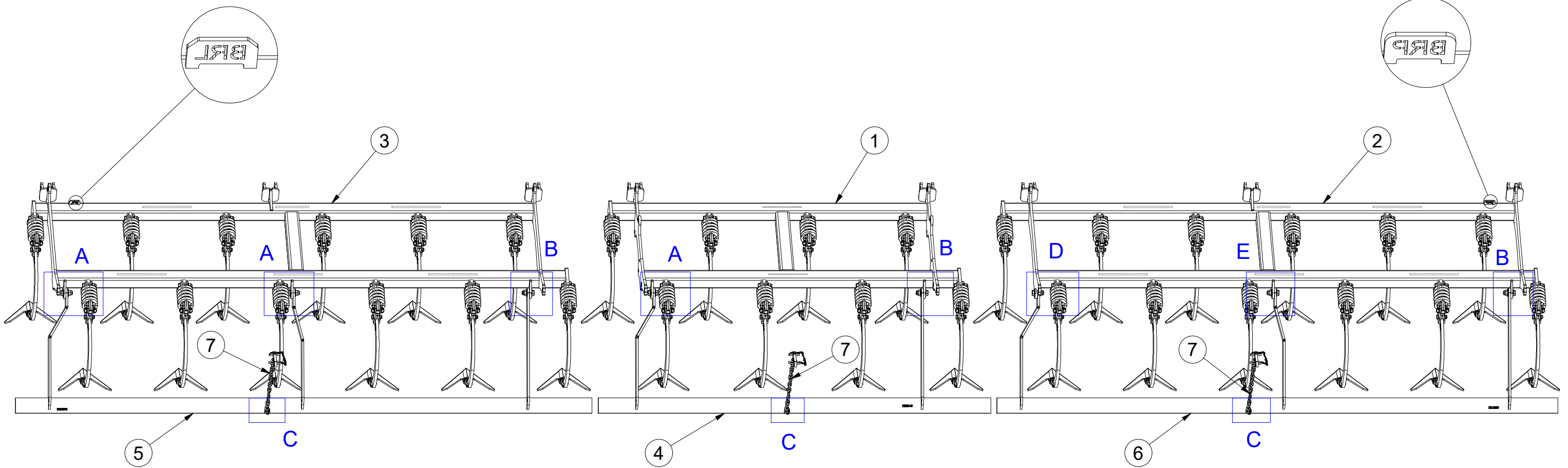

A

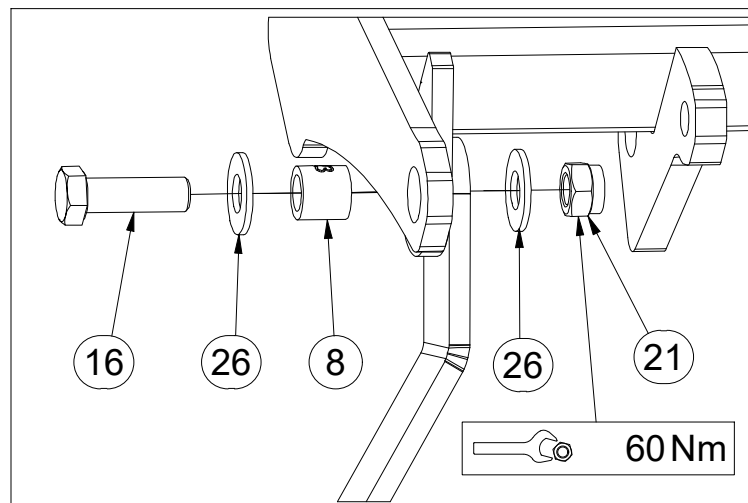

B

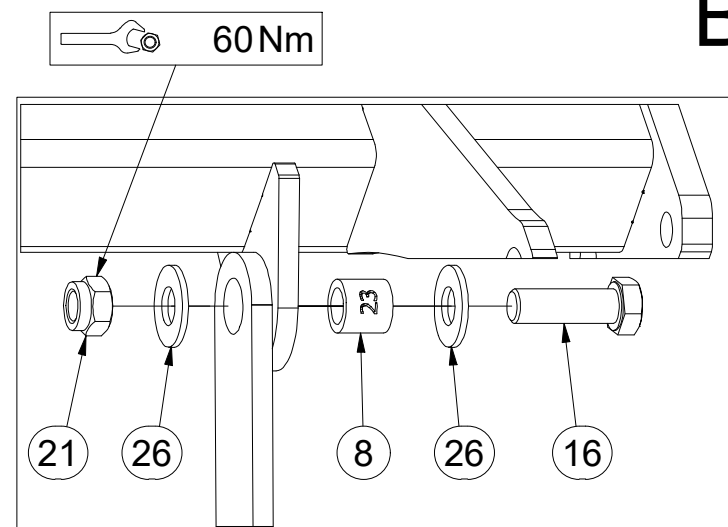

C

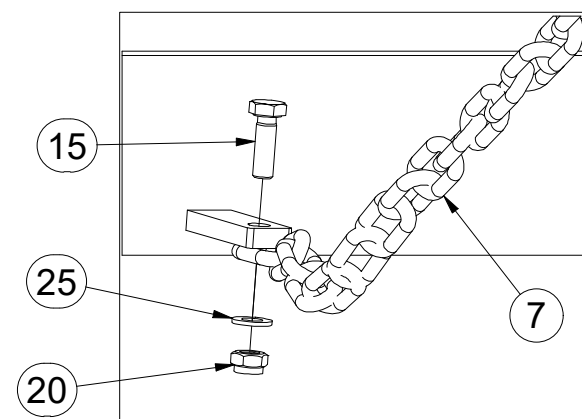

Pos.	Part Number	Pcs.
1	VZ00015183	1
2	3012394	1
3	3012392	1
4	3009549	1
5	3009578	1
6	3012399	1
7	4001641	3
8	4022223	7
15	m01092	3
16	m04355	8
20	m04503	3
21	m03683	8
25	m01203	3
26	m05651	16

ⒸZ SADA RADLIC

Ⓓ SCHARSATZ

Ⓕ KIT DE SOCS

ⒼB SET OF PLOUGHSHARES

ⒺU КОМПЛЕКТ ЛАП

ⒶL ZESTAW REDLIC



3012376

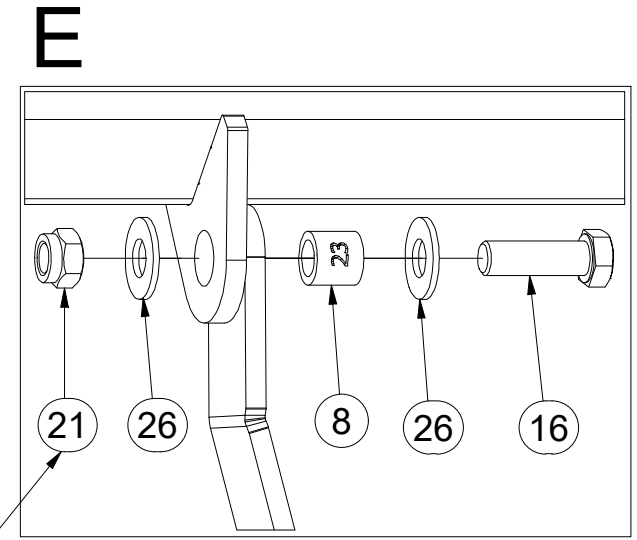
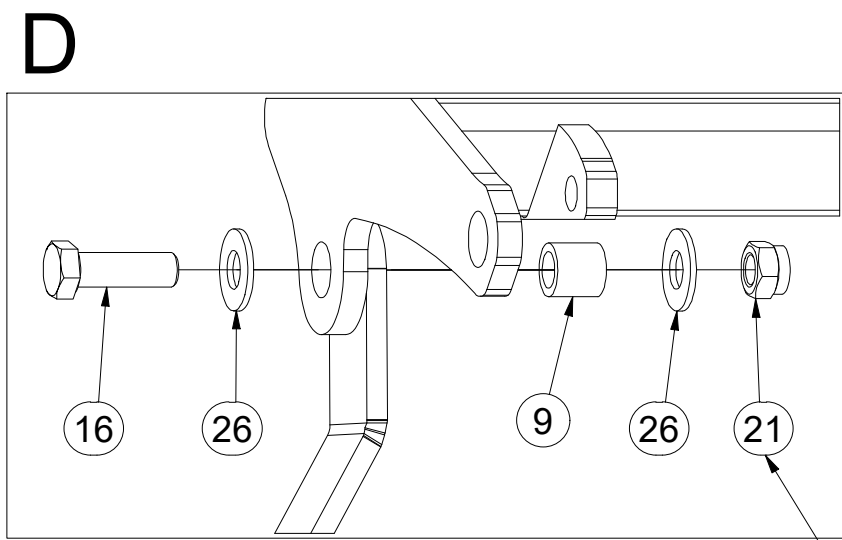
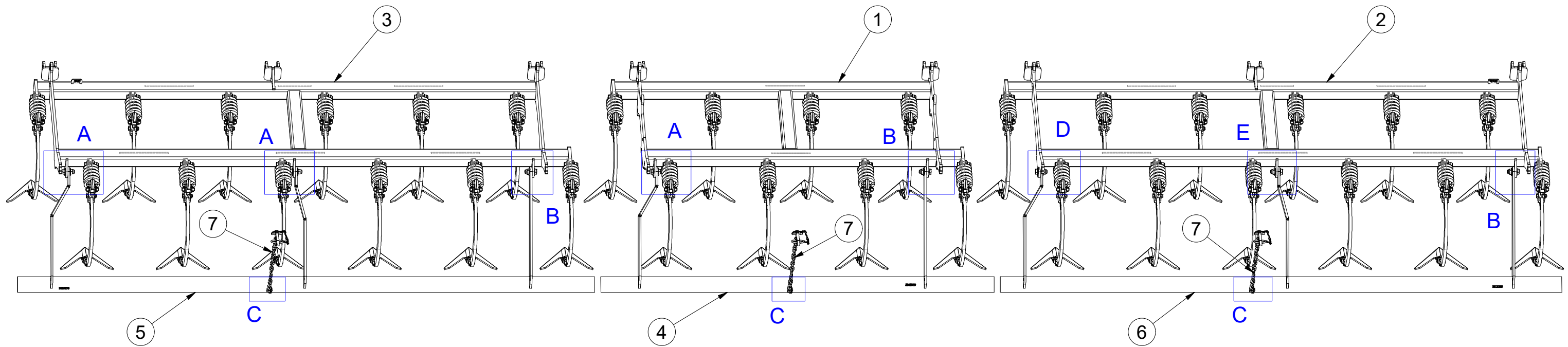

60Nm

Pos.	Part Number	Pcs.
1	VZ00015183	1
2	3012394	1
3	3012392	1
4	3009549	1
5	3009578	1
6	3012399	1
7	4001641	3
8	4022223	7
9	9004702	1
16	m04355	8
21	m03683	8
26	m05651	16

ⒸZ SADA RADLIC

Ⓓ SCHARSATZ

Ⓕ KIT DE SOCS

ⒼB SET OF PLOUGHSHARES

ⒺU КОМПЛЕКТ ЛАП

ⒽL ZESTAW REDLIC



3012392

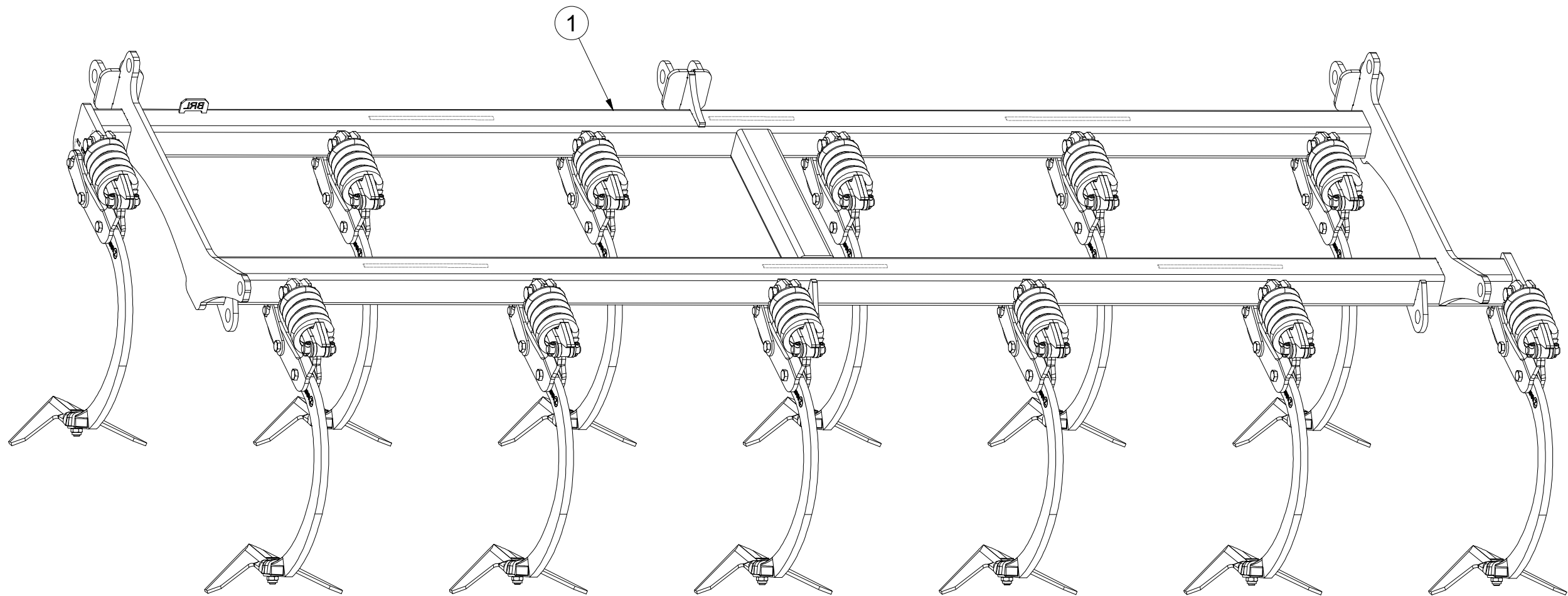
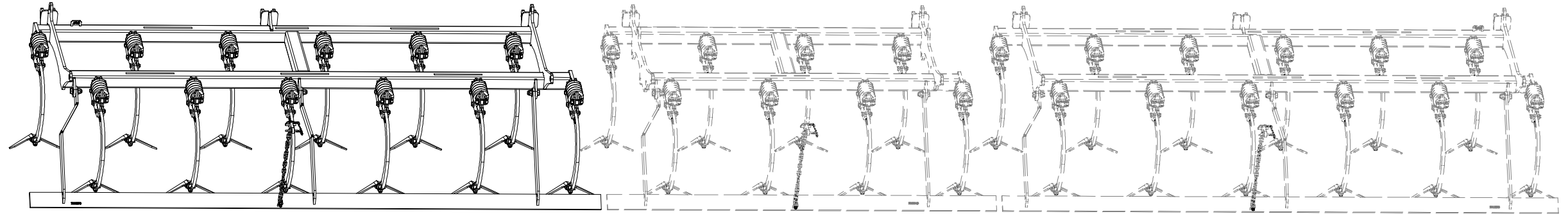

Pos.	Part Number	Pcs.
1	3012393	1

ⒸZ SADA RADLIC

Ⓓ SCHARSATZ

Ⓕ KIT DE SOCS

ⒸB SET OF PLOUGHSHARES

ⒸU КОМПЛЕКТ ЛАП

ⒸL ZESTAW REDLIC



3012392

1.

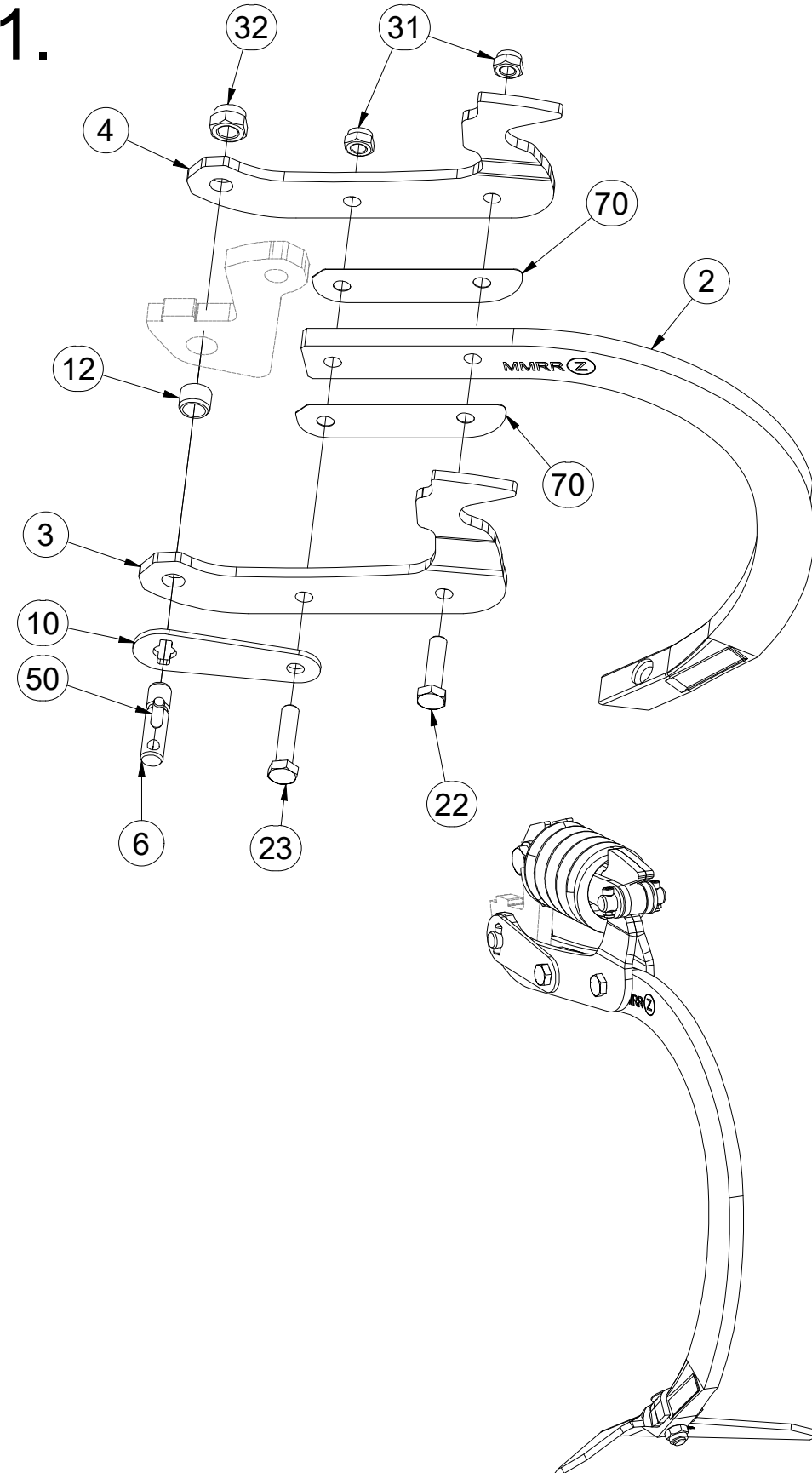

2.

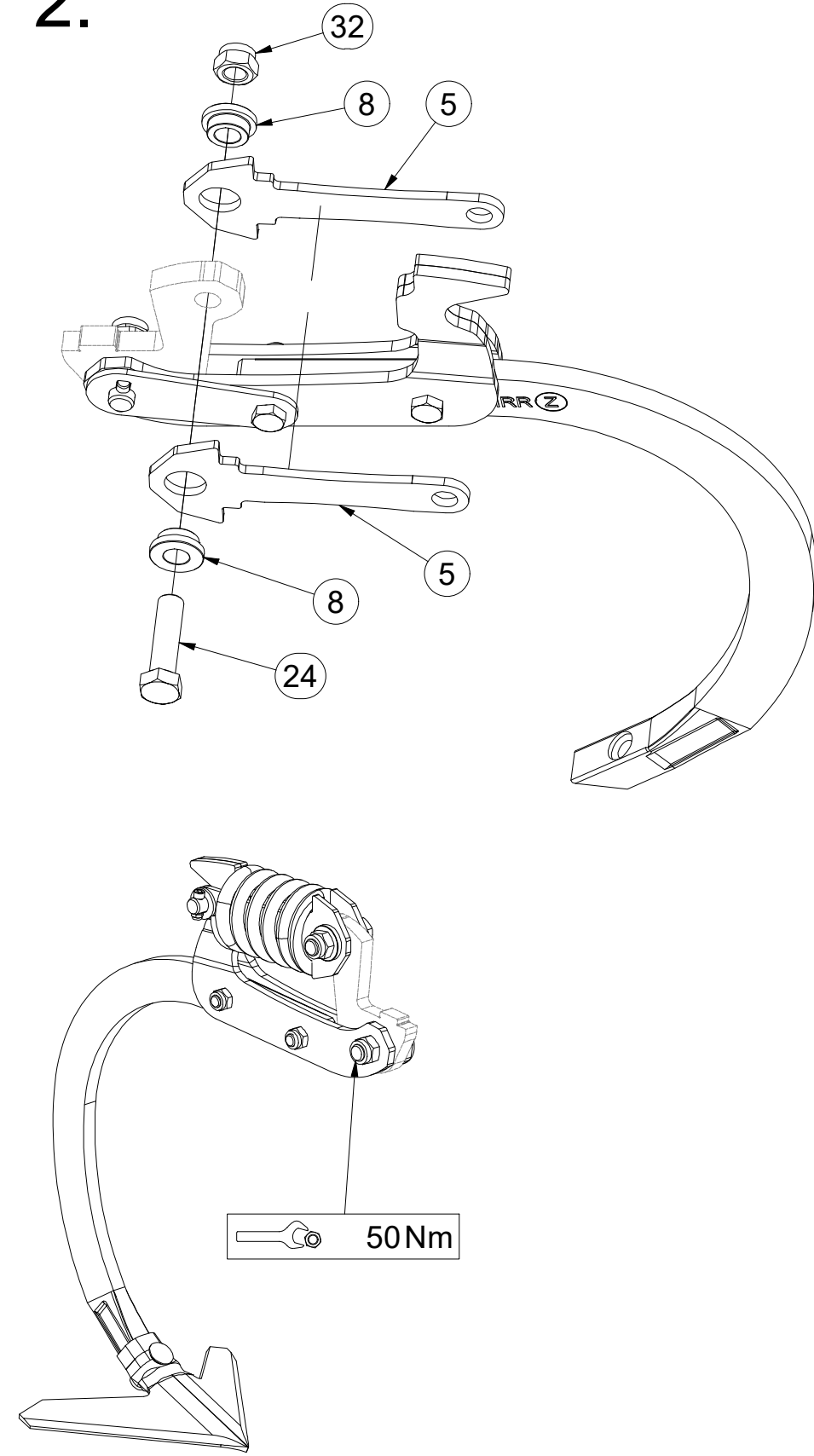

3.

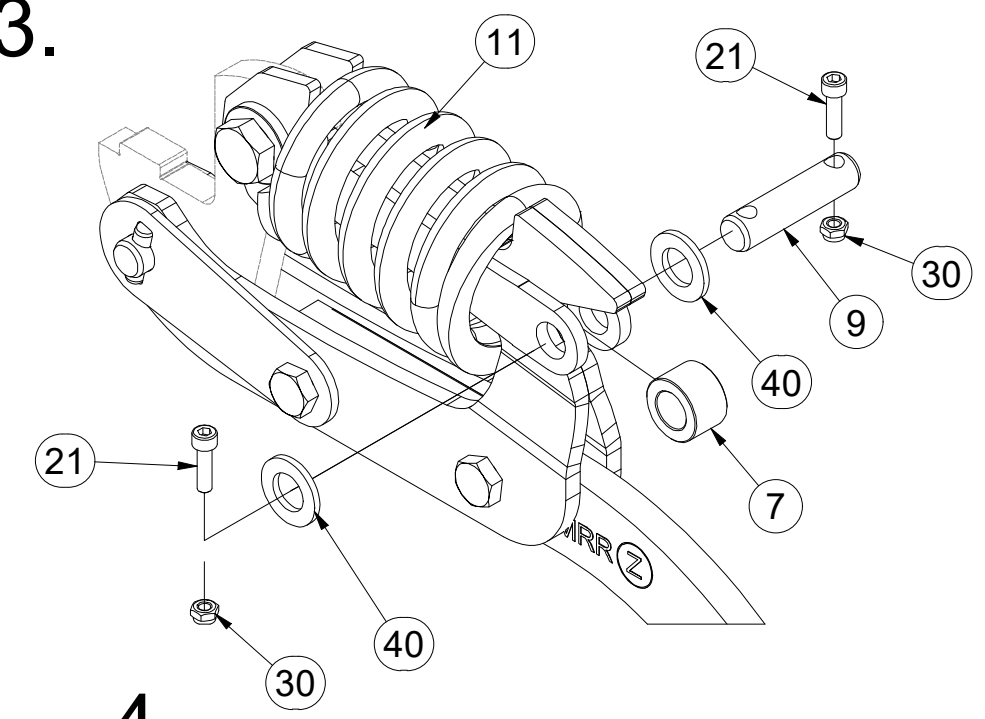

4.

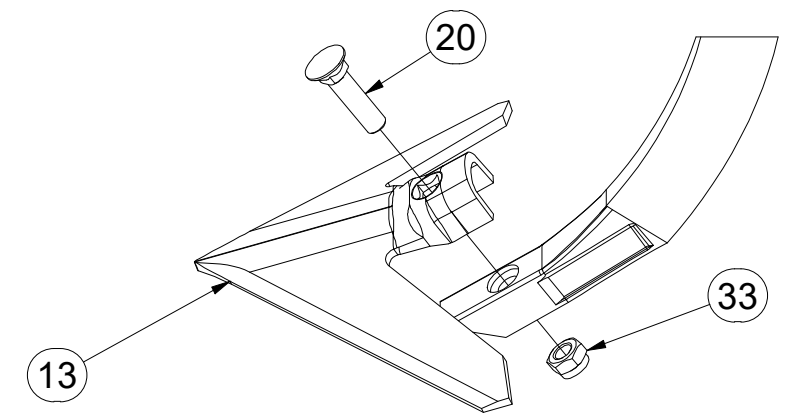

Pos.	Part Number	Pcs.	Pos.	Part Number	Pcs.
2	9005683	12	20	m10440	12
3	3012358	12	21	m15215	24
4	3012359	12	22	m06077	12
5	4024906	24	23	m03339	12
6	4024918	12	24	m14482	12
7	4009624	12	30	m05560	24
8	4014252	24	31	m04301	24
9	4015783	12	32	m03683	24
10	VZ00003688	12	33	m21001	12
11	m18880	12	40	m14971	24
12	m18882	12	50	m18826	12
13	3000236-KOO	12	70	4014863	24

Ⓒ CZ SADA RADLIC

Ⓓ D SCHARSATZ

Ⓕ F KIT DE SOCS

VZ00015183

Ⓖ GB SET OF PLOUGHSHARES

Ⓡ RU КОМПЛЕКТ ЛАП

Ⓟ PL ZESTAW REDLIC

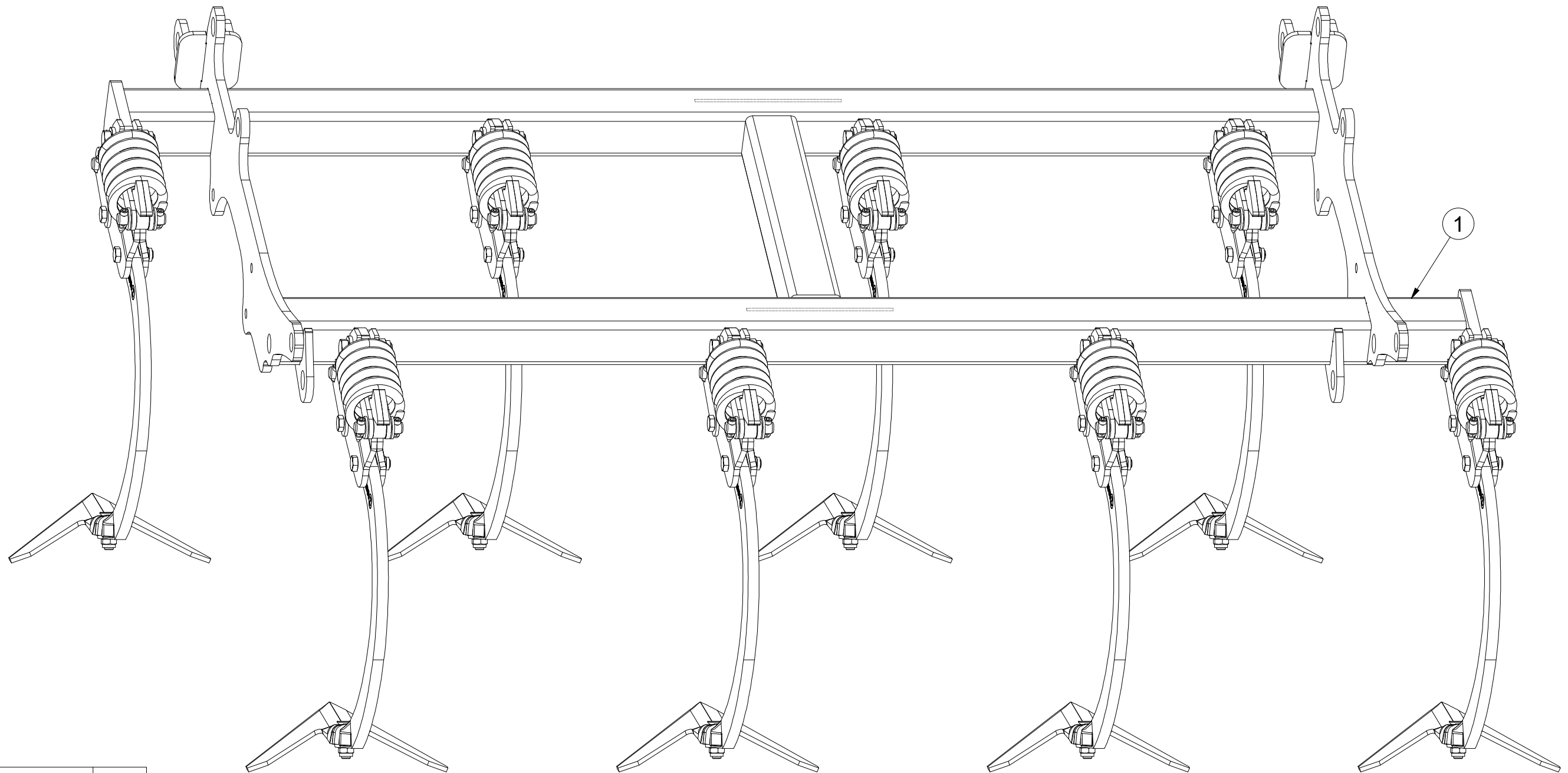
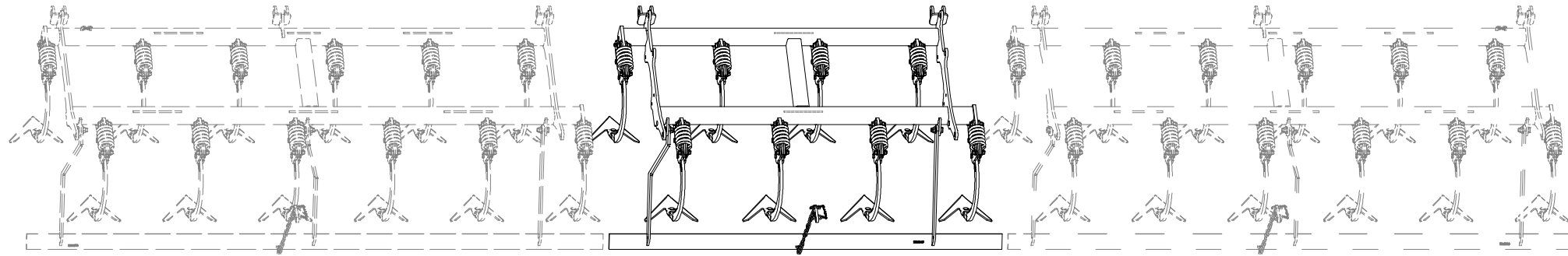

Pos.	Part Number	Pcs.
1	VZ00015184	1

Ⓒ SADA RADLIC

Ⓓ SCHARSATZ

Ⓕ KIT DE SOCS

VZ00015183

Ⓖ SET OF PLOUGHSHARES

Ⓡ КОМПЛЕКТ ЛАП

Ⓢ ZESTAW REDLIC

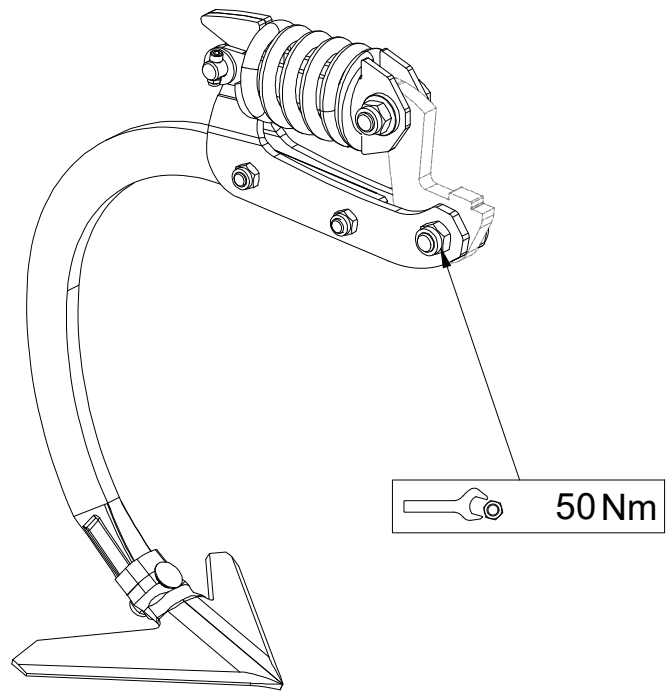
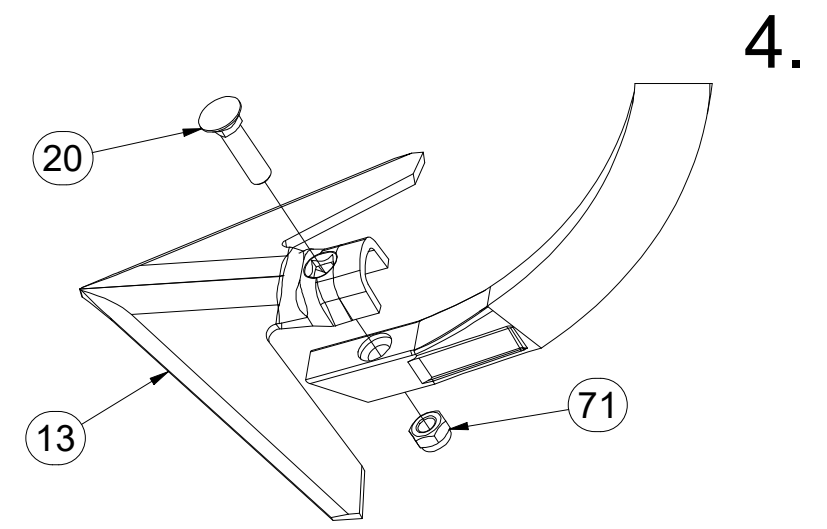
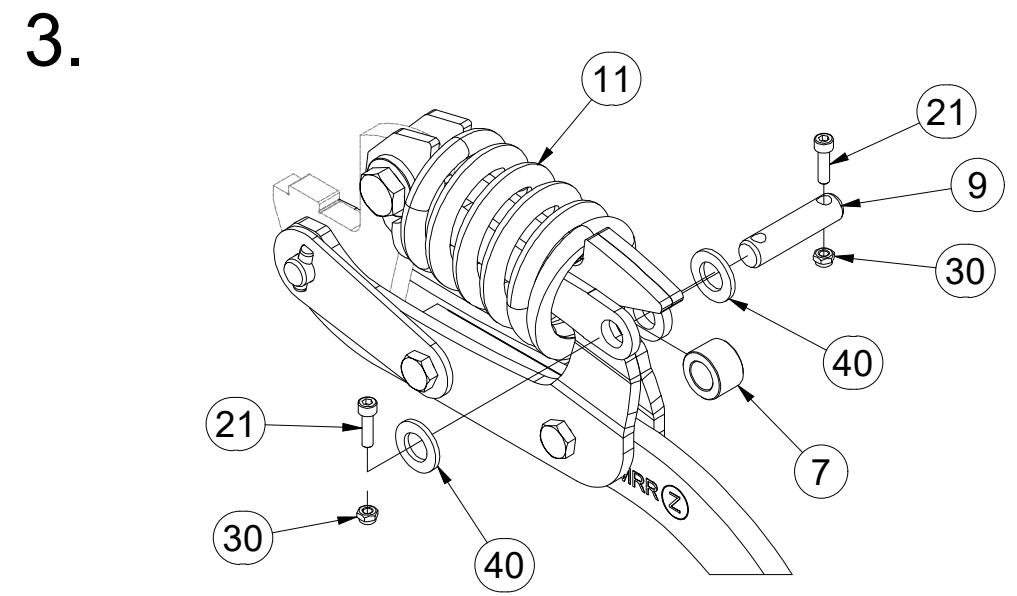
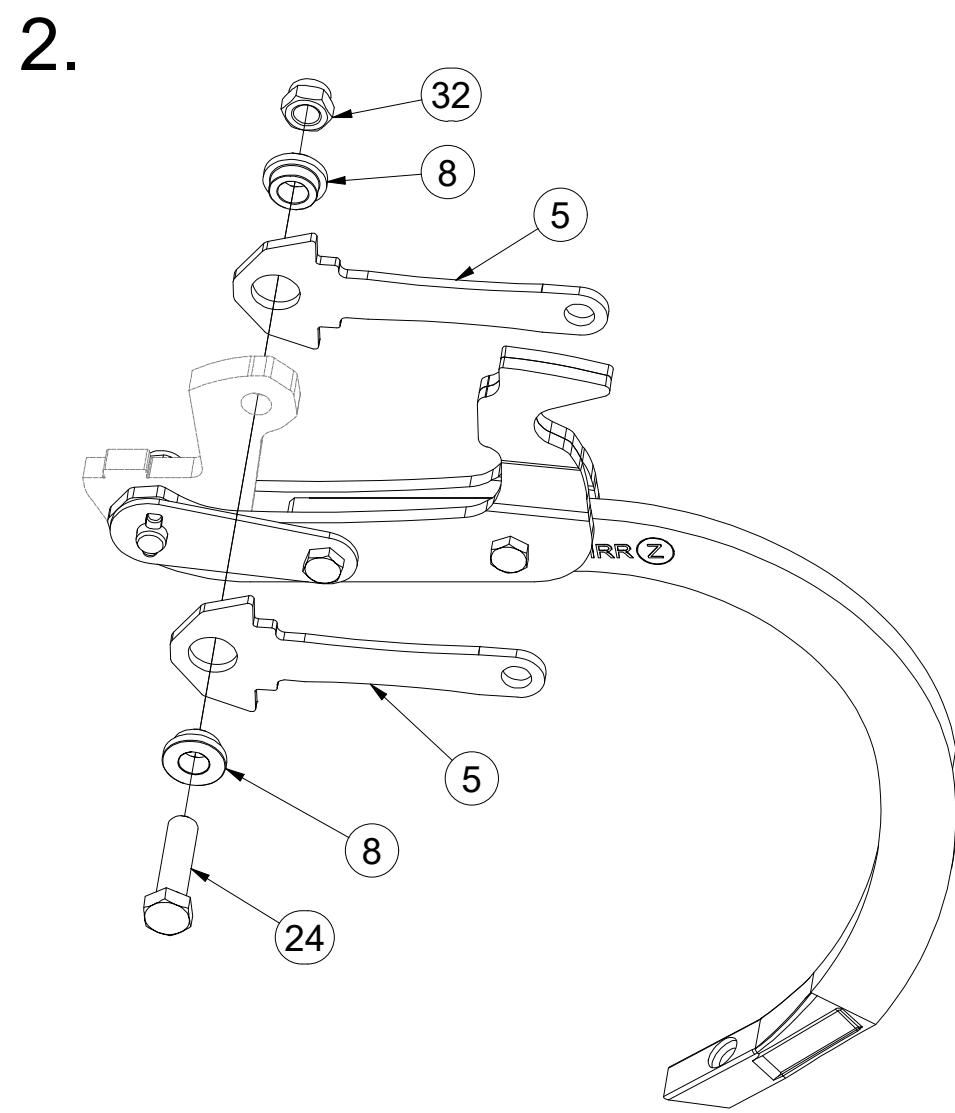
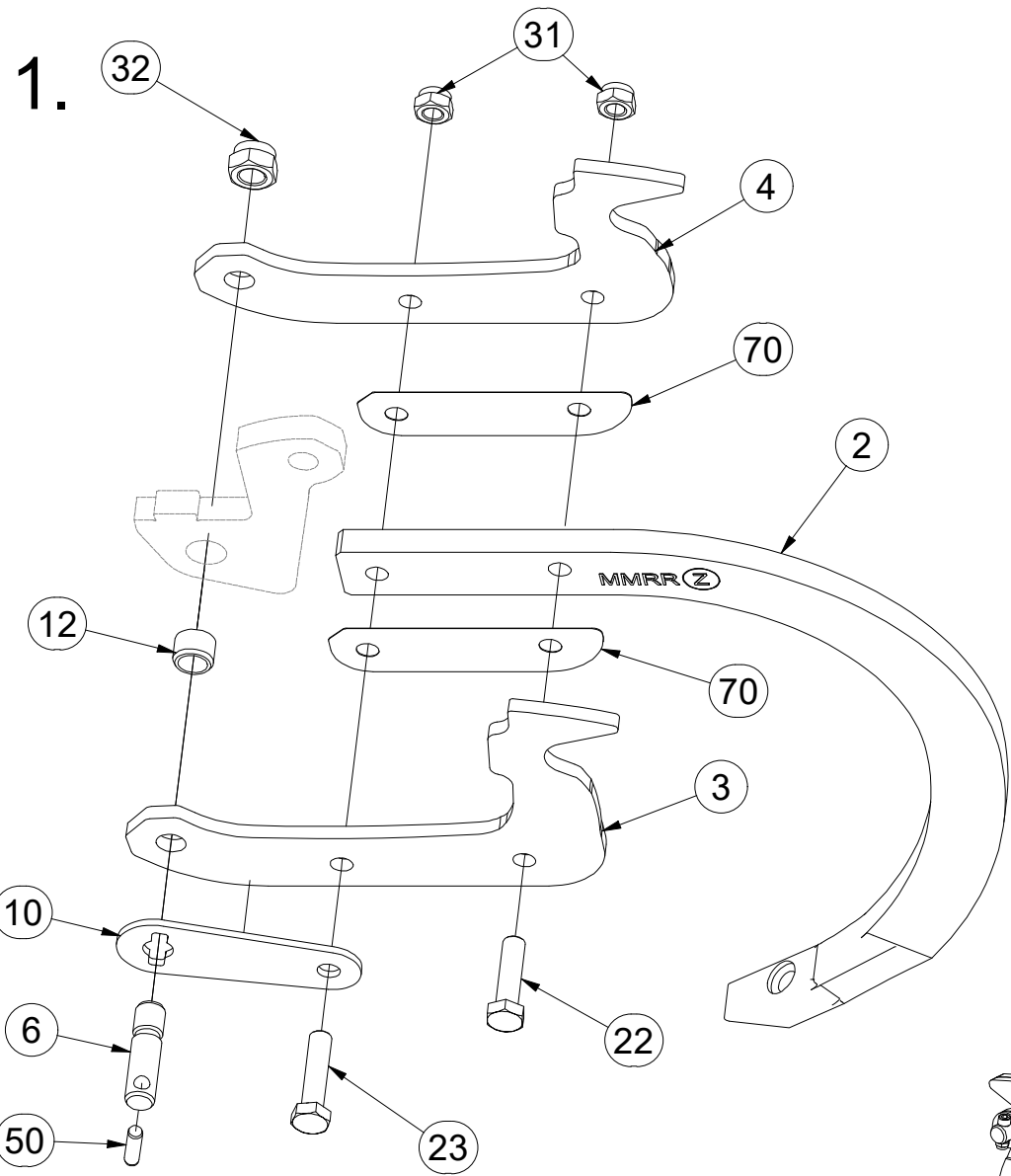

Pos.	Part Number	Pcs.	Pos.	Part Number	Pcs.
2	9005683	8	20	m10440	8
3	3012358	8	21	m15215	16
4	3012359	8	22	m06077	8
5	4024906	16	23	m03339	8
6	4024918	8	24	m14482	8
7	4009624	8	30	m05560	16
8	4014252	16	31	m04301	16
9	4015783	8	32	m03683	16
10	VZ00003688	8	40	m14971	16
11	m18880	8	50	m18826	8
12	m18882	8	70	4014863	16
13	3000236-KOO	8	71	m21001	8

ⒸZ SADA RADLIC

Ⓓ SCHARSATZ

Ⓕ KIT DE SOCS

ⒸB SET OF PLOUGHSHARES

ⒸU КОМПЛЕКТ ЛАП

ⒸL ZESTAW REDLIC



3012394

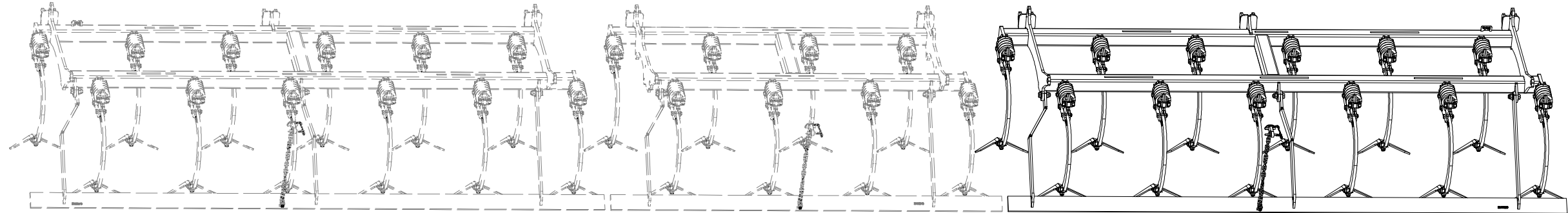

Pos.	Part Number	Pcs.
1	3012397	1
13	3000236-KOO	12

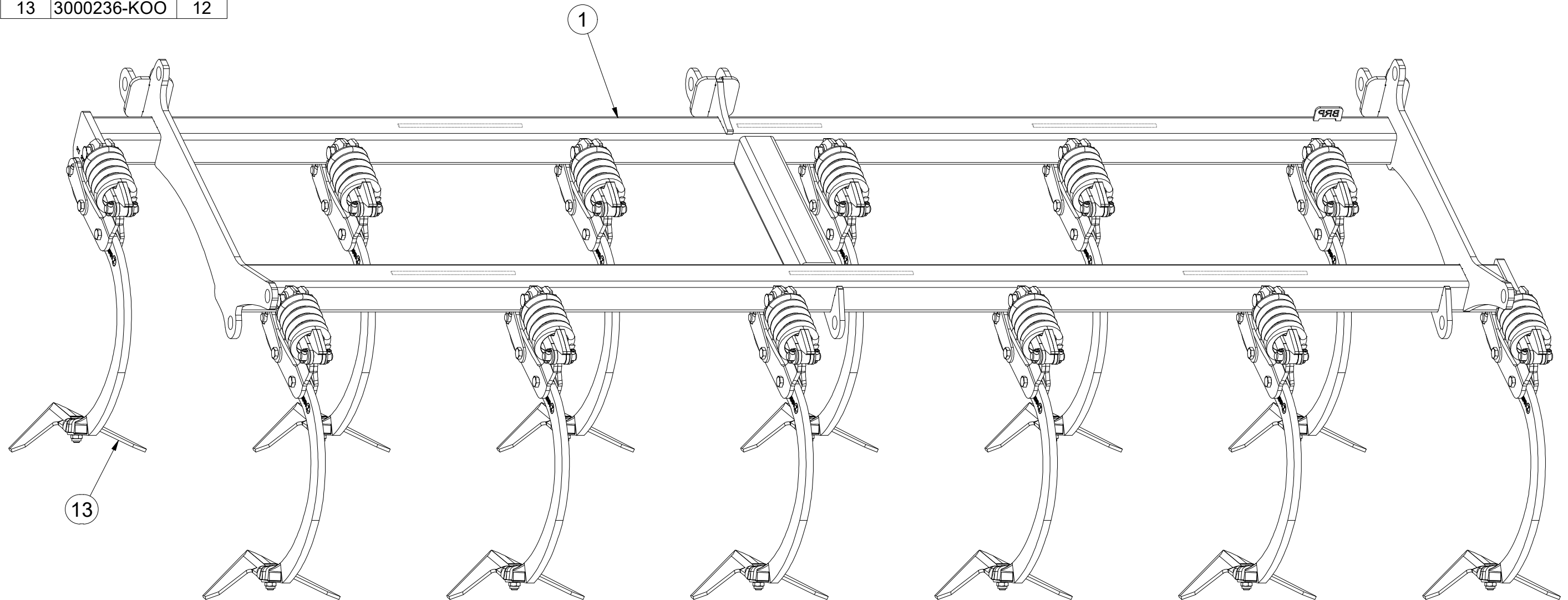

Ⓒ SADA RADLIC

Ⓓ SCHARSATZ

Ⓕ KIT DE SOCS

Ⓖ SET OF PLOUGHSHARES

Ⓡ КОМПЛЕКТ ЛАП

Ⓢ ZESTAW REDLIC



3012394

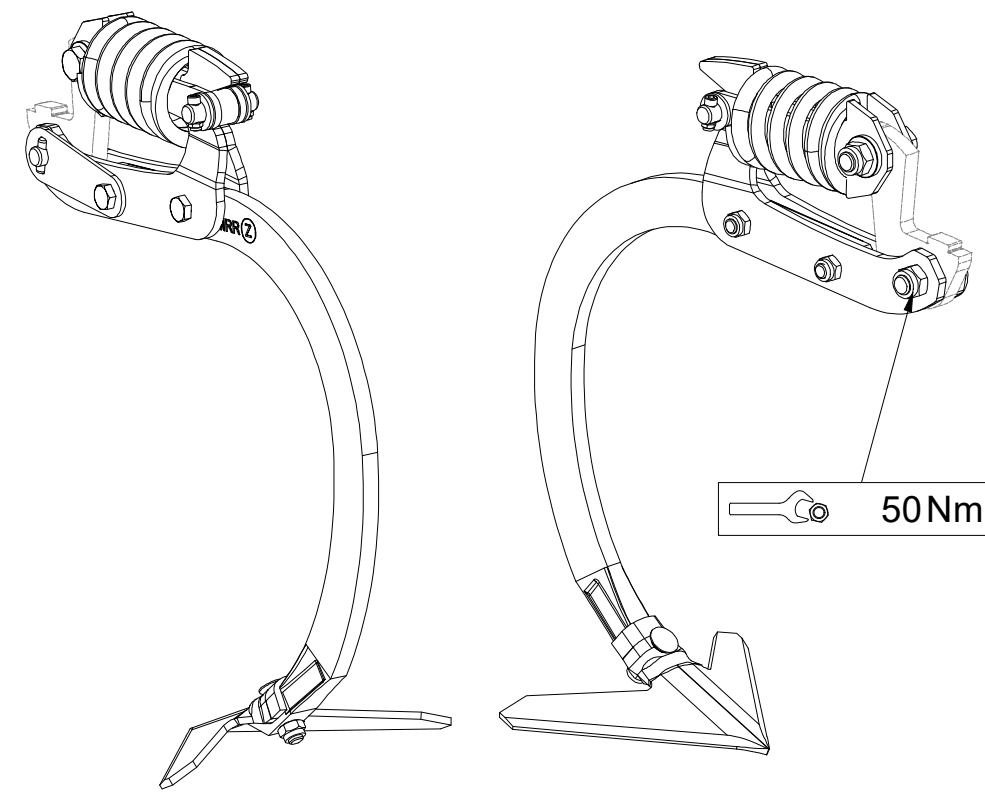
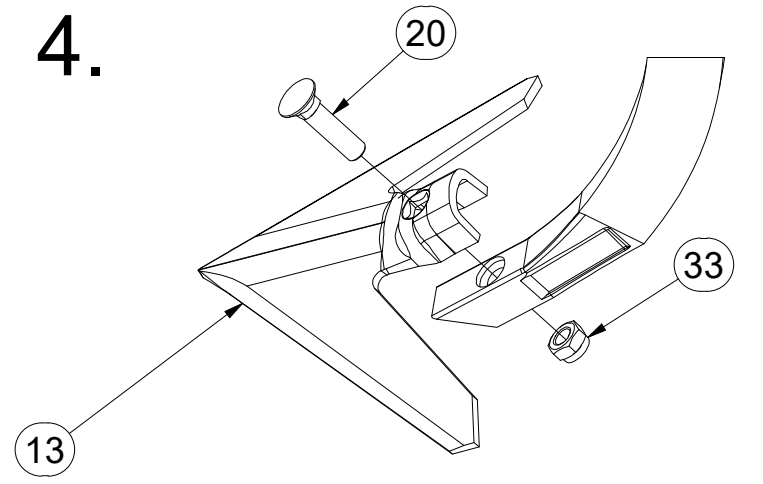
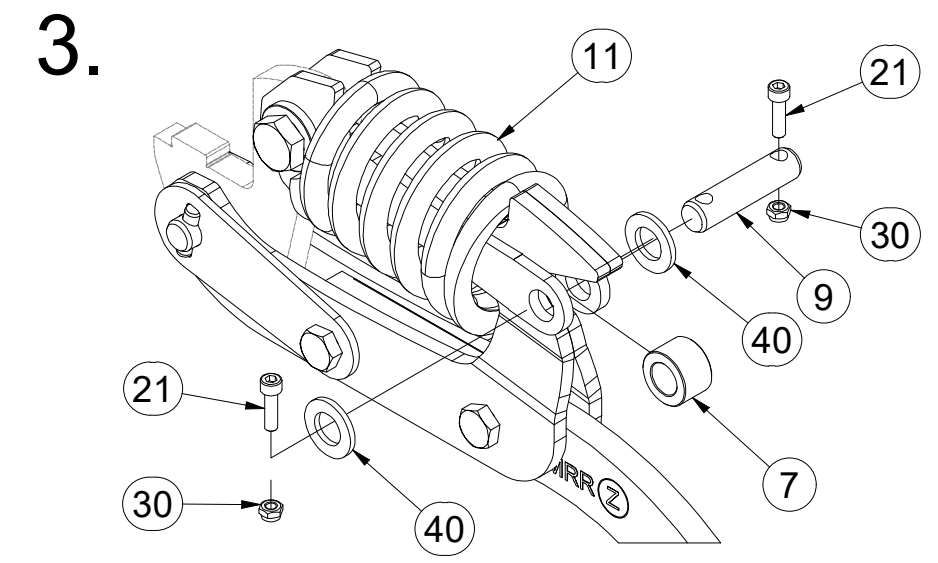
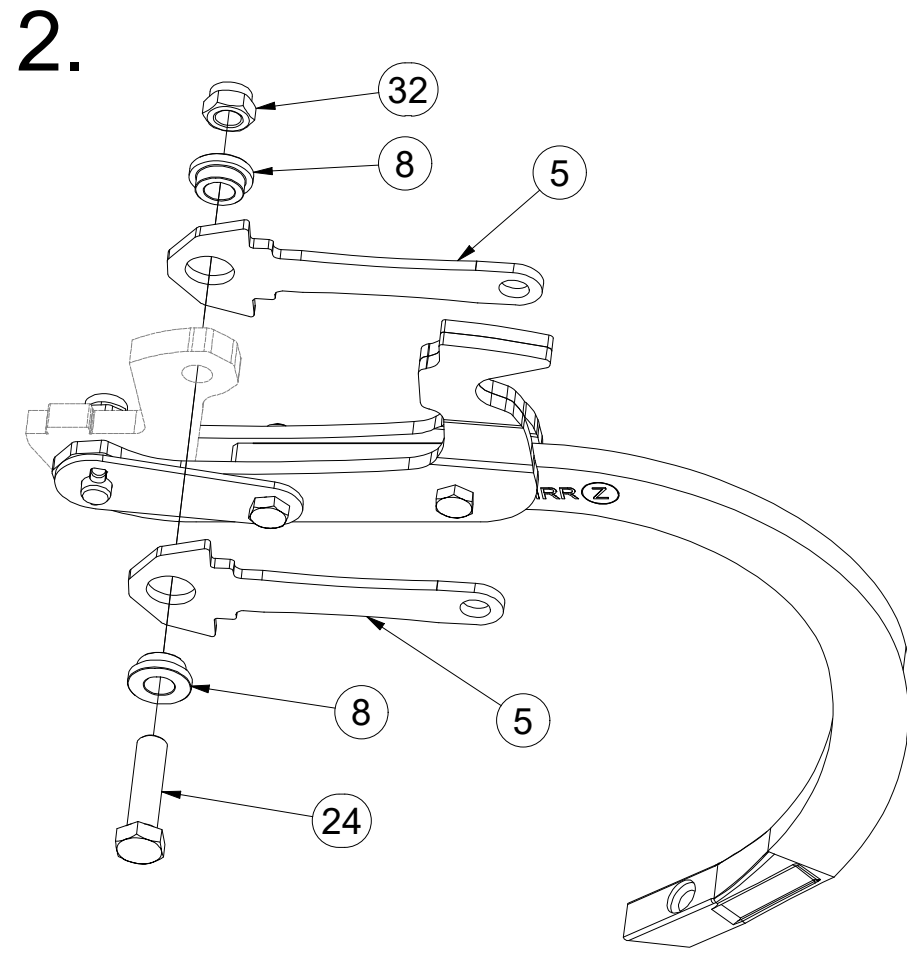
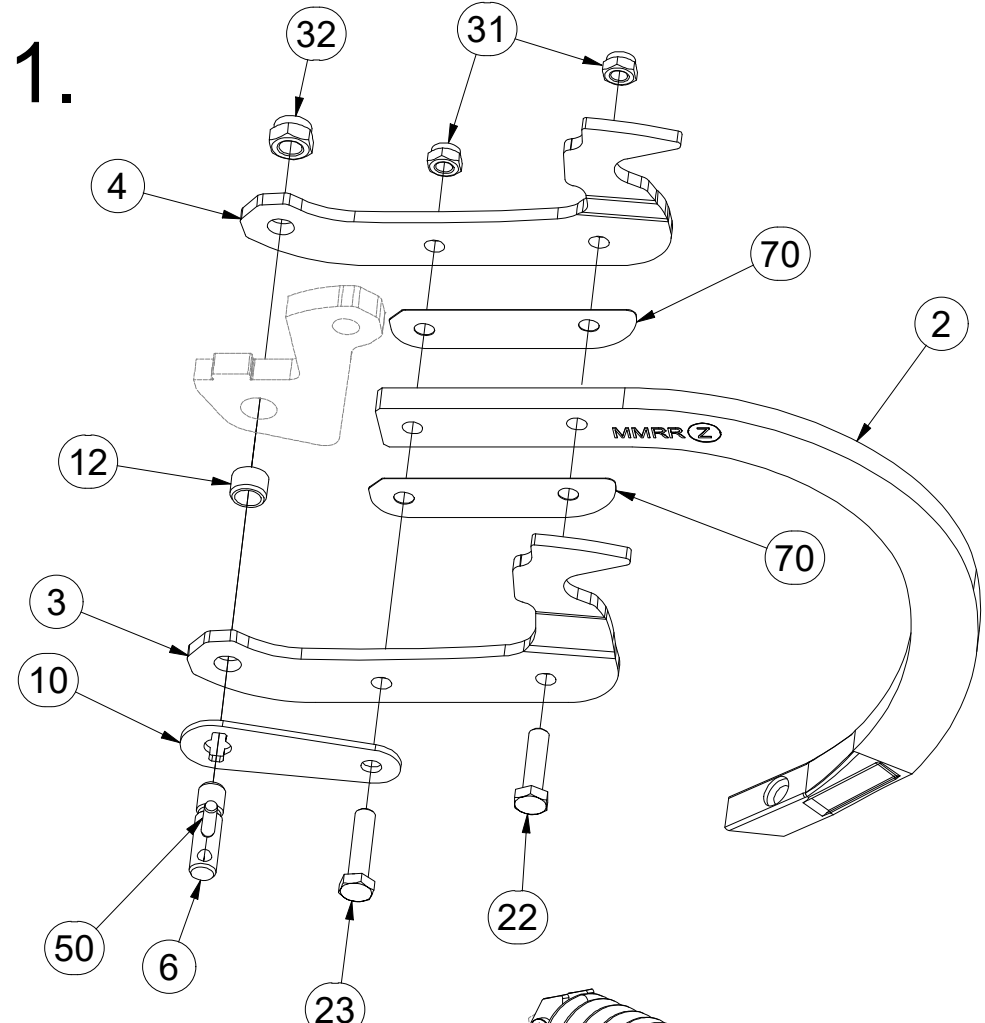

Pos.	Part Number	Pcs.	Pos.	Part Number	Pcs.
2	9005683	12	20	m10440	12
3	3012358	12	21	m15215	24
4	3012359	12	22	m06077	12
5	4024906	24	23	m03339	12
6	4024918	12	24	m14482	12
7	4009624	12	30	m05560	24
8	4014252	24	31	m04301	24
9	4015783	12	32	m03683	24
10	VZ00003688	12	40	m14971	24
11	m18880	12	50	m18826	12
12	m18882	12	33	m21001	12
13	3000236-KOO	12	70	4014863	24

- Ⓒ SADA ZADNÍCH VÁLCŮ
- Ⓓ SATZ HINTERE WALZEN
- Ⓕ KIT DE ROULEAUX ARRIÈRE

- Ⓖ SET OF REAR ROLLERS
- Ⓡ КОМПЛЕКТ ЗАДНИХ КАТКОВ
- Ⓟ ZESTAW TYLNYCH WAŁÓW



VZ00019544

Pos.	Part Number	Pcs.
1	3011920	1
2	VZ00012468	1

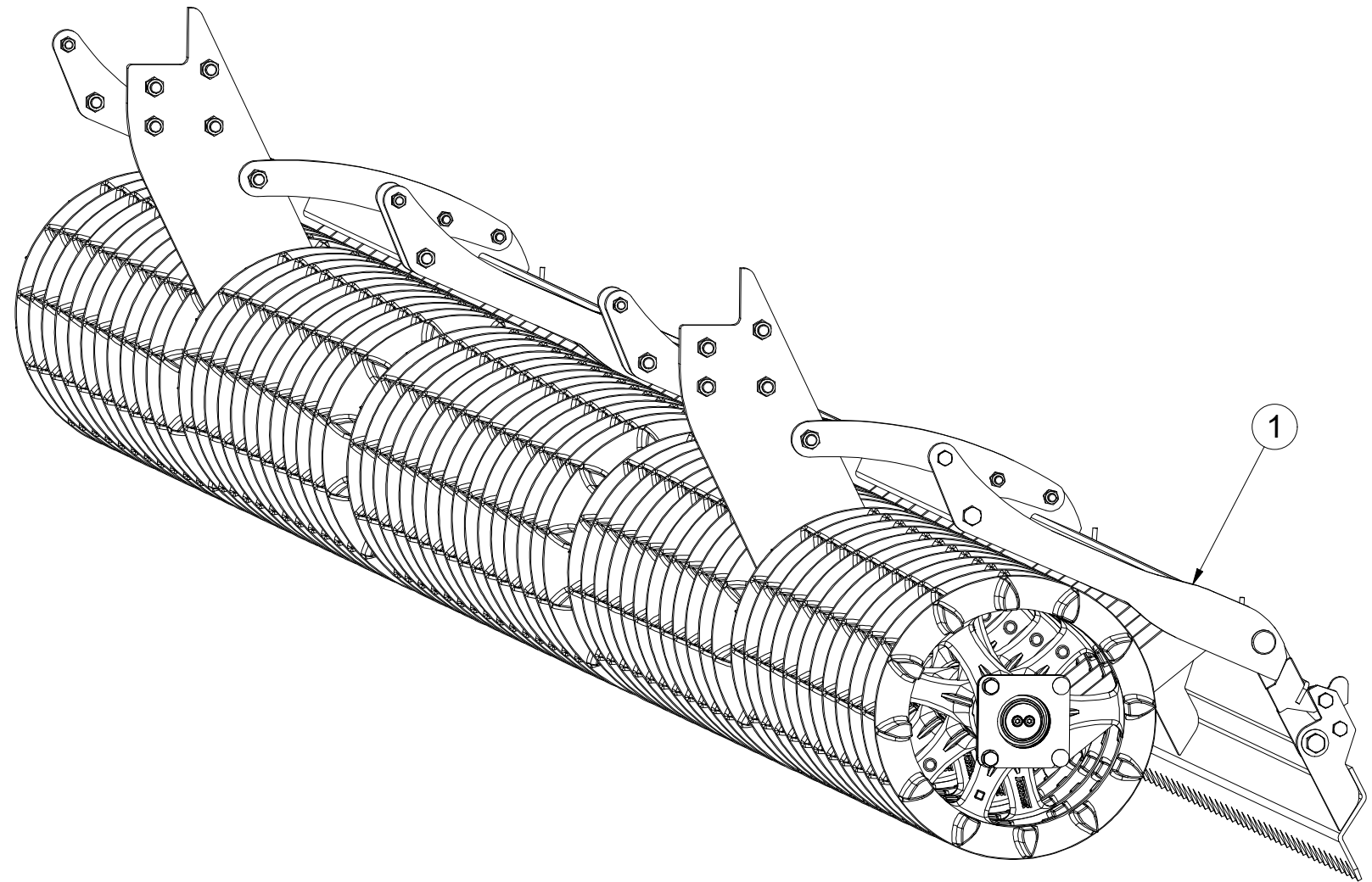
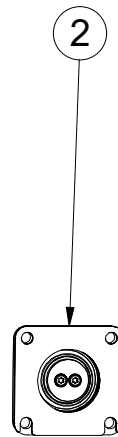
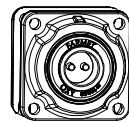
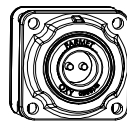

- ⒸZ SADA ZADNÍCH VÁLCŮ
- Ⓓ SATZ HINTERE WALZEN
- Ⓕ KIT DE ROULEAUX ARRIÈRE

3011920

- ⒸB SET OF REAR ROLLERS
- Ⓔ КОМПЛЕКТ ЗАДНИХ КАТКОВ
- Ⓖ ZESTAW TYLNYCH WAŁÓW

Farmet

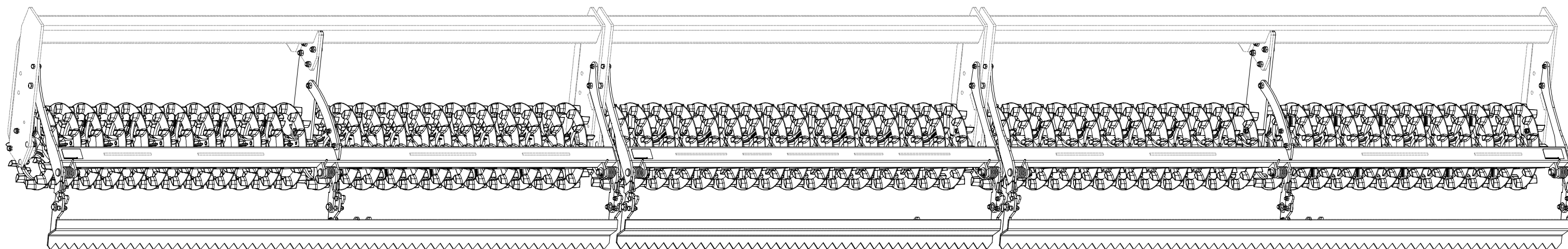

CZ SADA ZADNÍCH VÁLCŮ
 D SATZ HINTERE WALZEN
 F KIT DE ROULEAUX ARRIÈRE

GB SET OF REAR ROLLERS
 RU КОМПЛЕКТ ЗАДНИХ КАТКОВ
 PL ZESTAW TYLNYCH WAŁÓW



3011920

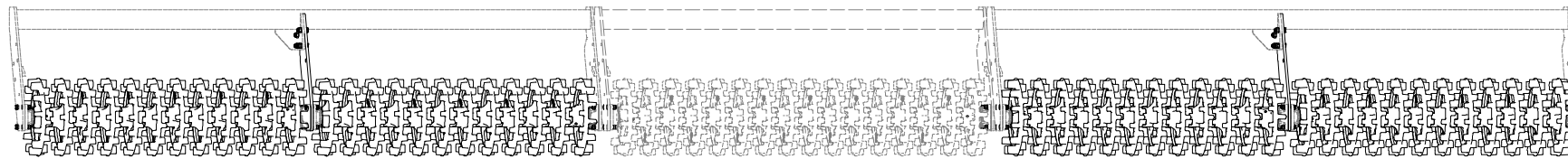

Pos.	Part Number	Pcs.
1	3011836	4
8	VZ00014132	8
11	VZ00011865	54
27	4016995	10
57	m13958	20
100	4010015	20
101	4024556	20

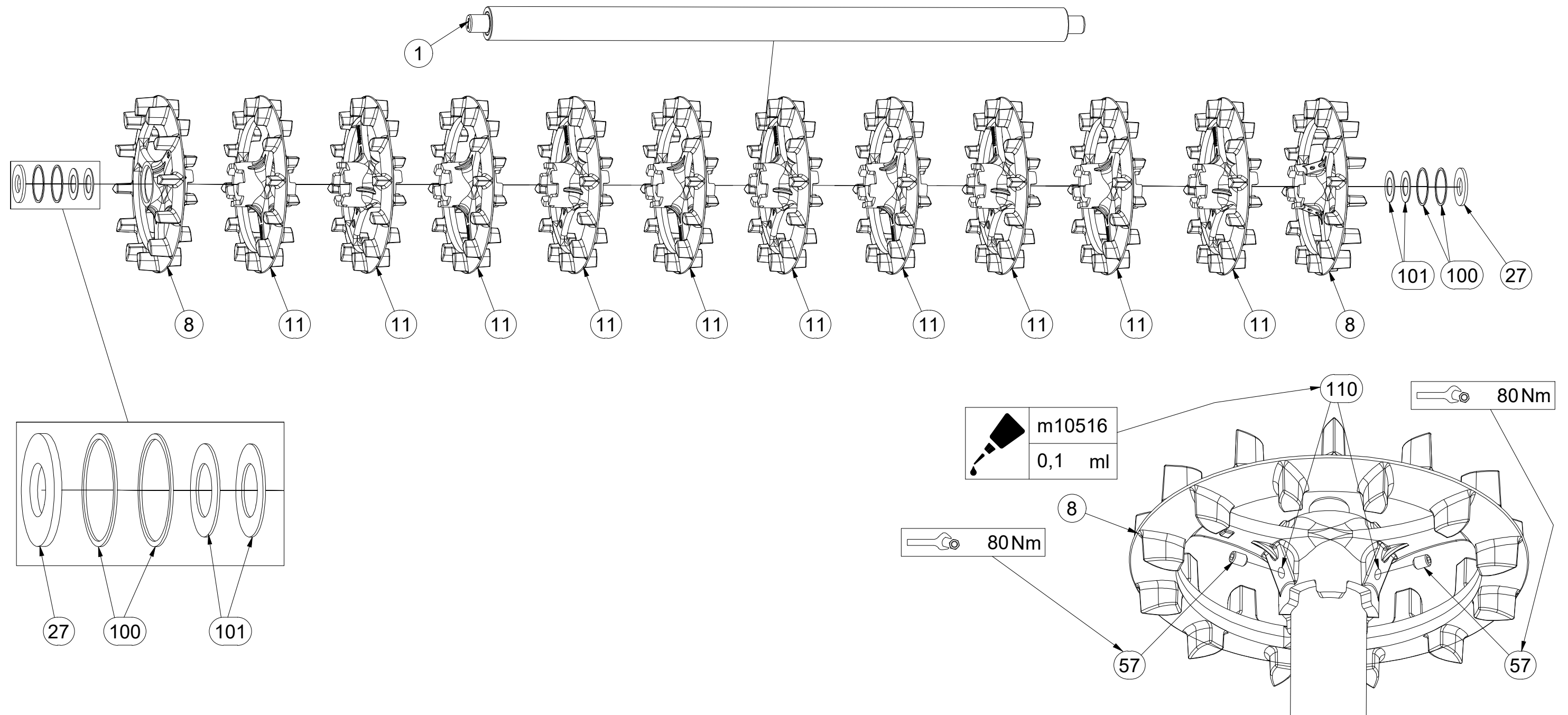

ⒸZ SADA ZADNÍCH VÁLCŮ

Ⓓ SATZ HINTERE WALZEN

Ⓕ KIT DE ROULEAUX ARRIÈRE

ⒸB SET OF REAR ROLLERS

ⒸU КОМПЛЕКТ ЗАДНИХ КАТКОВ

ⒸL ZESTAW TYLNYCH WAŁÓW



3011920

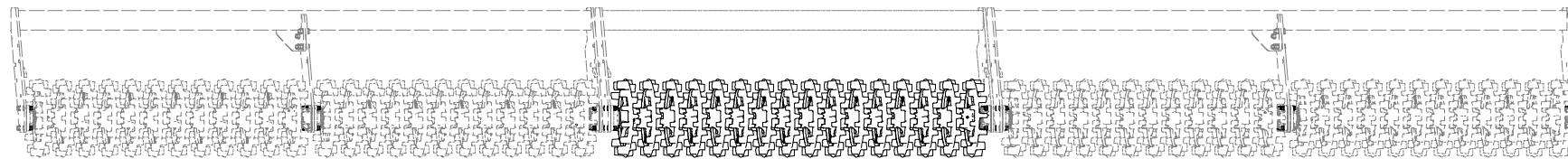

Pos.	Part Number	Pcs.
2	3011293	1
9	VZ00011862	2
11	VZ00011865	54
27	4016995	10
57	m13958	20
100	4010015	20
101	4024556	20

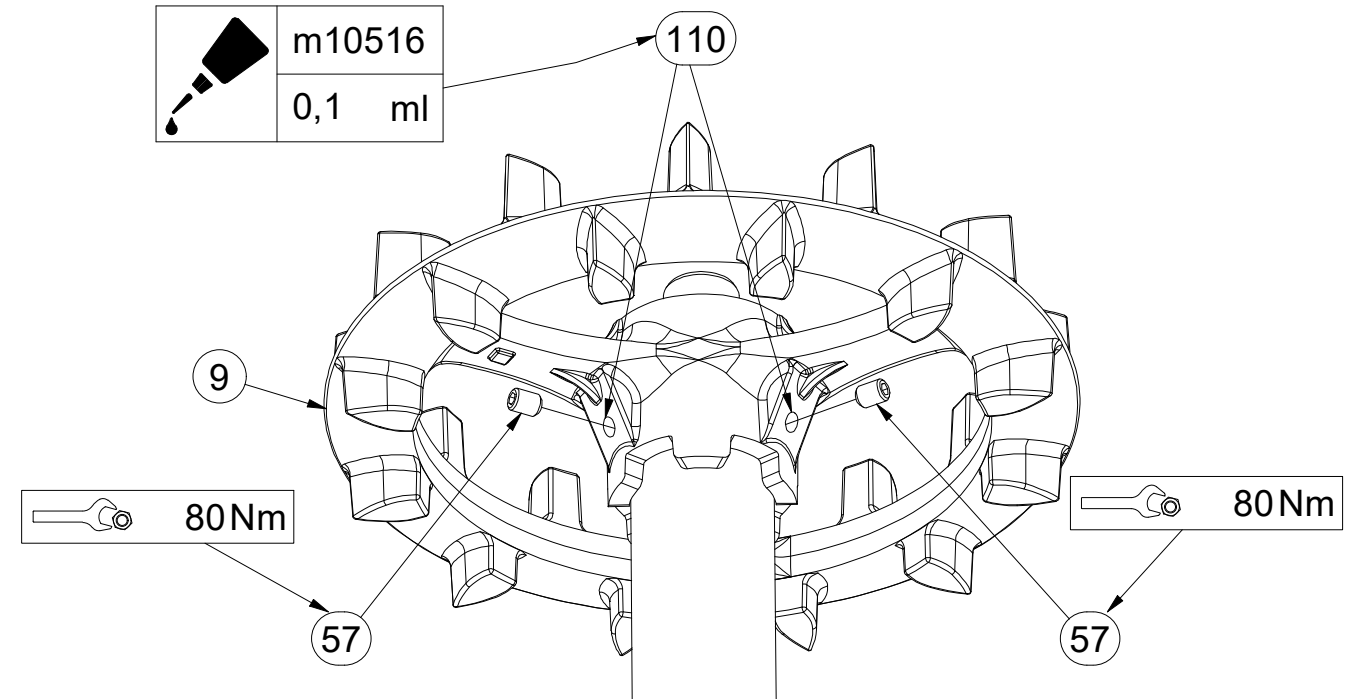
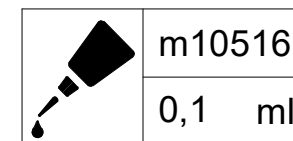
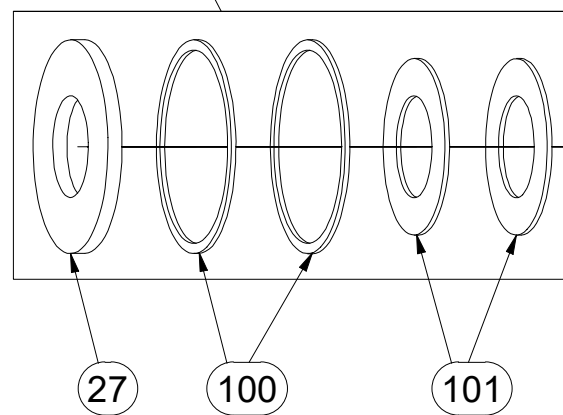
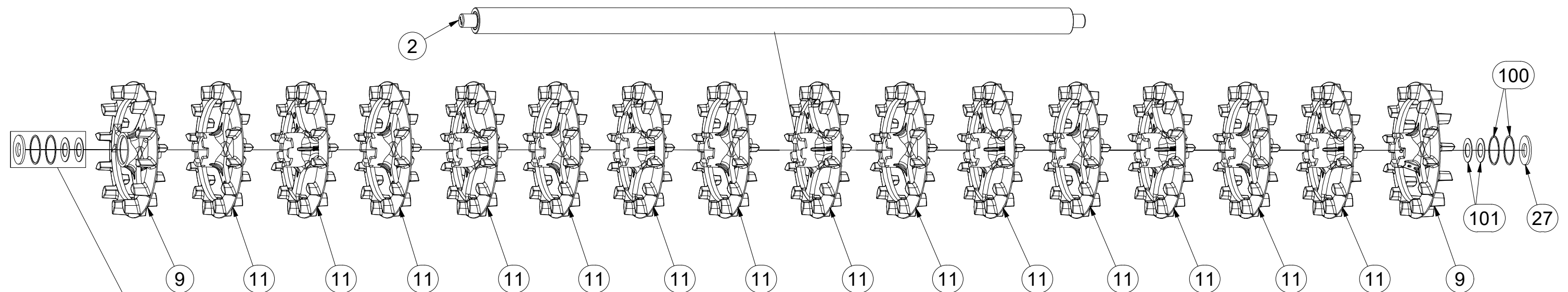

- ⒸZ SADA ZADNÍCH VÁLCŮ
- Ⓓ SATZ HINTERE WALZEN
- Ⓕ KIT DE ROULEAUX ARRIÈRE

- ⒼB SET OF REAR ROLLERS
- ⒹU КОМПЛЕКТ ЗАДНИХ КАТКОВ
- ⒹL ZESTAW TYLNYCH WAŁÓW



3011920

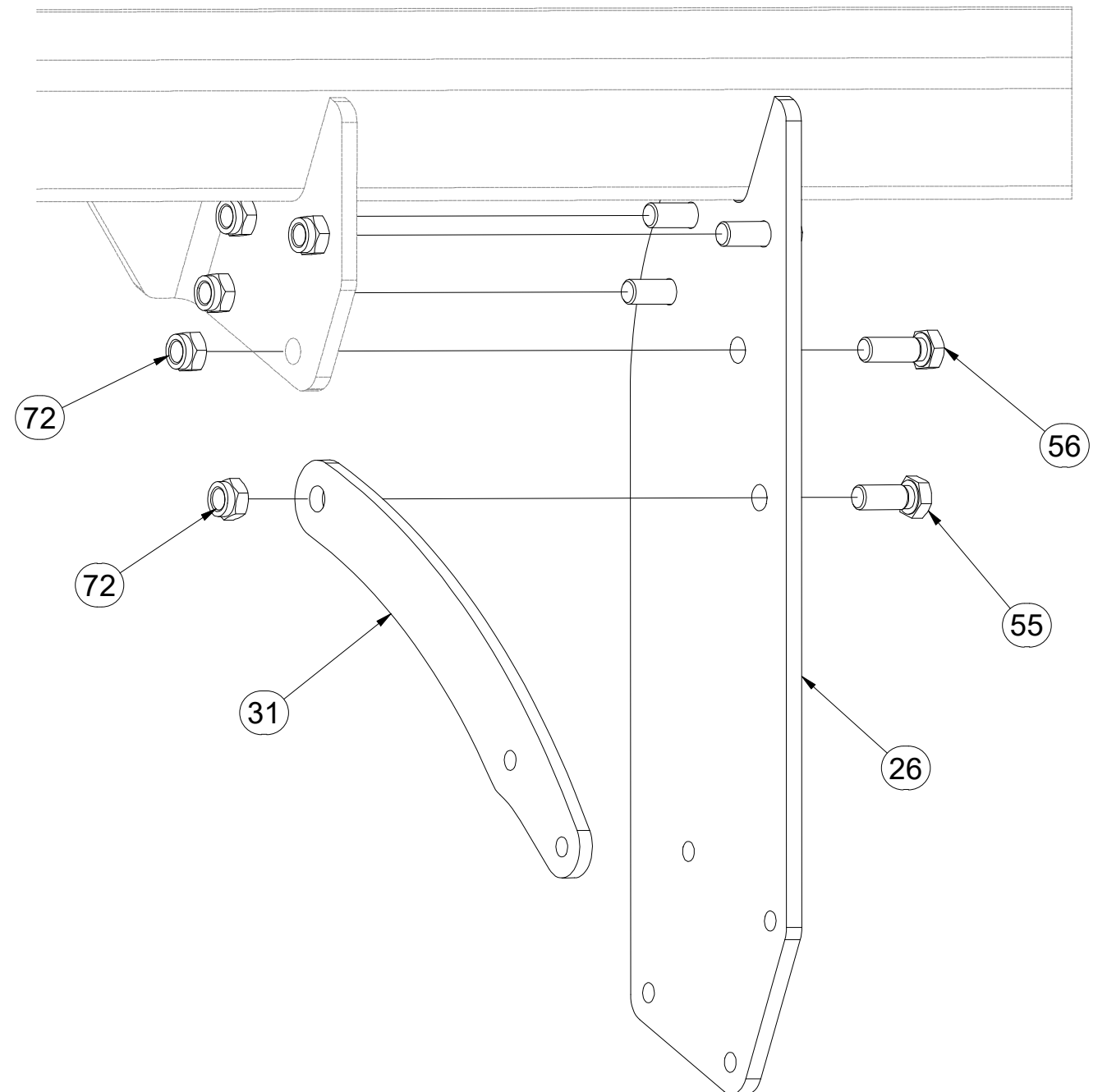
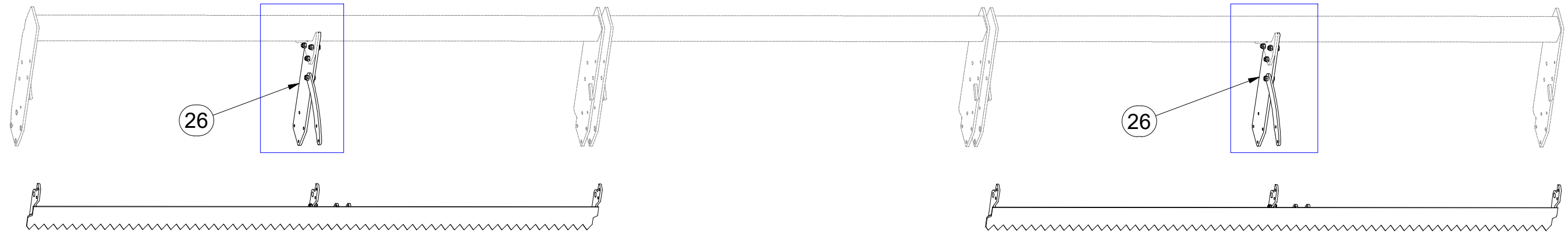

Pos.	Part Number	Pcs.
26	4005384	2
31	4013508	2
55	m01129	8
56	m02254	8
72	m03683	24

(CZ) SADA ZADNÍCH VÁLČŮ
 (D) SATZ HINTERE WALZEN
 (F) KIT DE ROULEAUX ARRIÈRE

(GB) SET OF REAR ROLLERS
 (RU) КОМПЛЕКТ ЗАДНИХ КАТКОВ
 (PL) ZESTAW TYLNYCH WAŁÓW



3011920

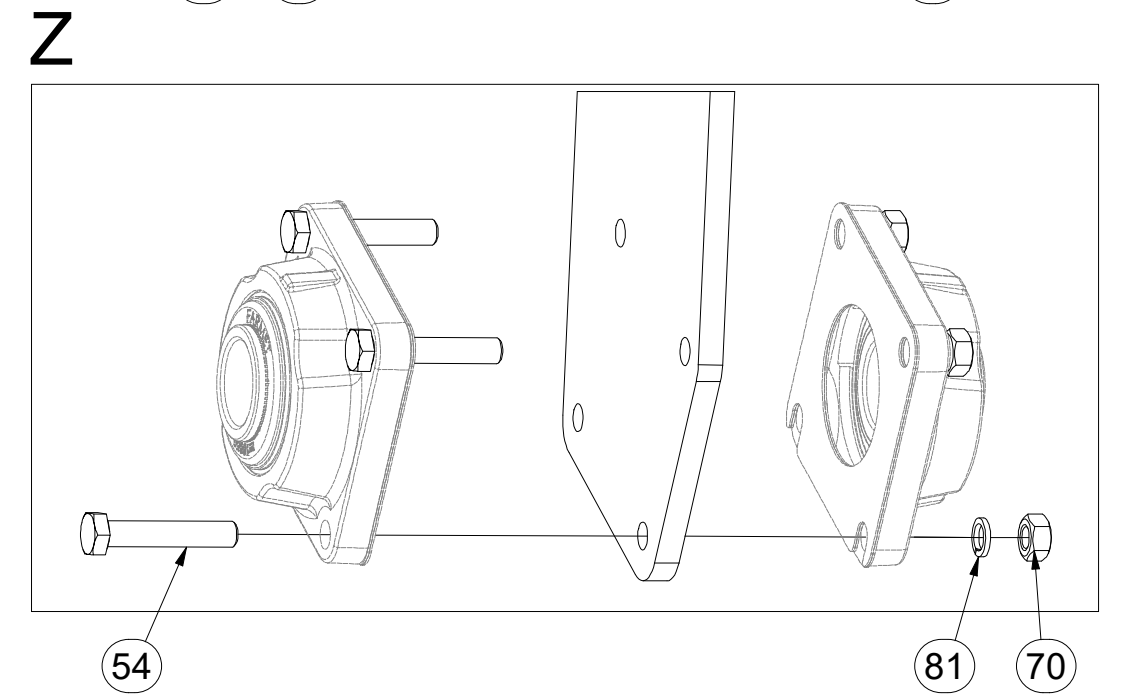
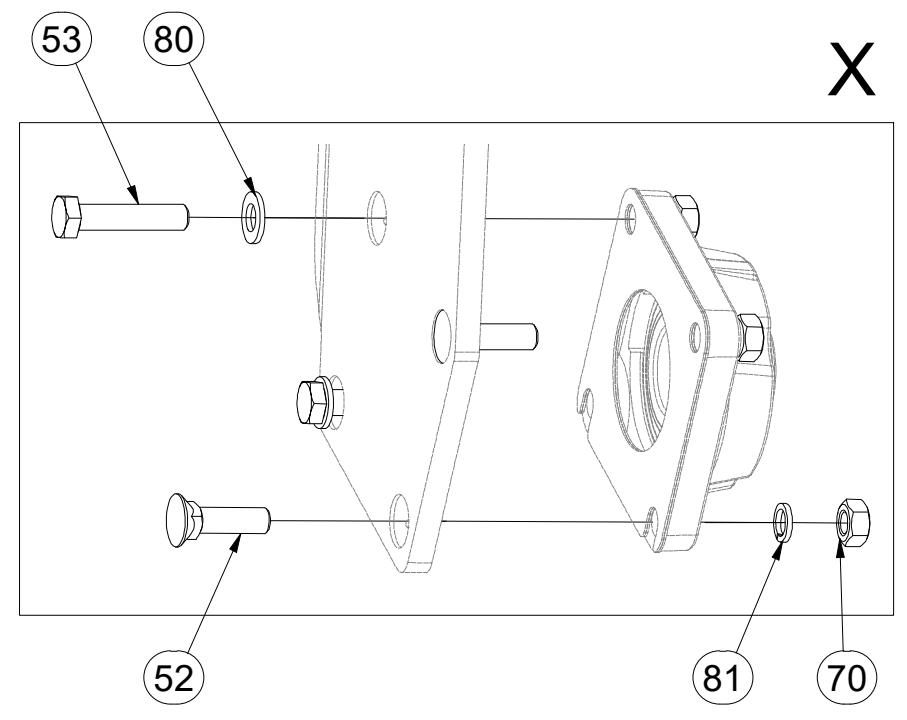
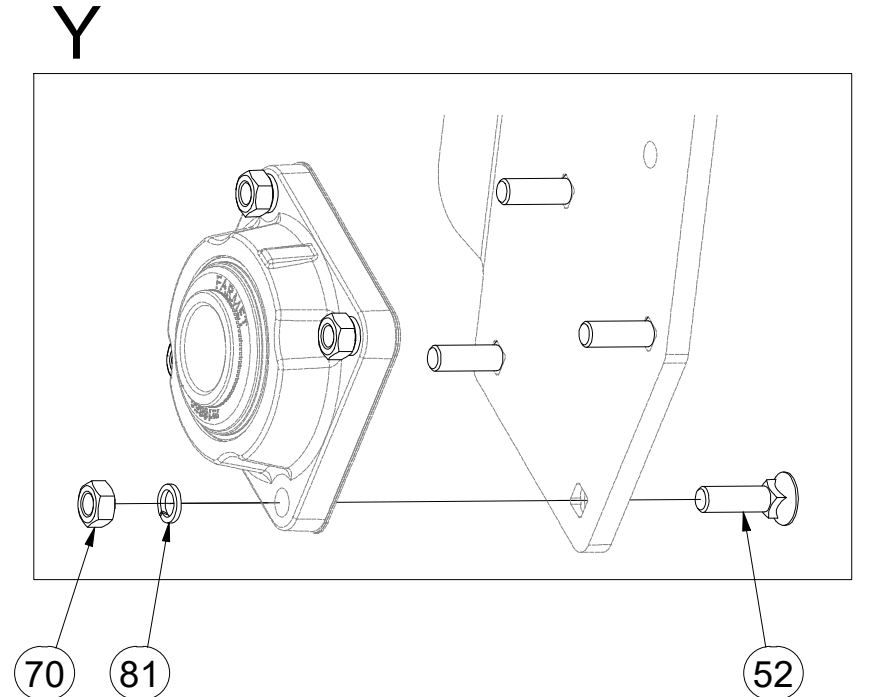
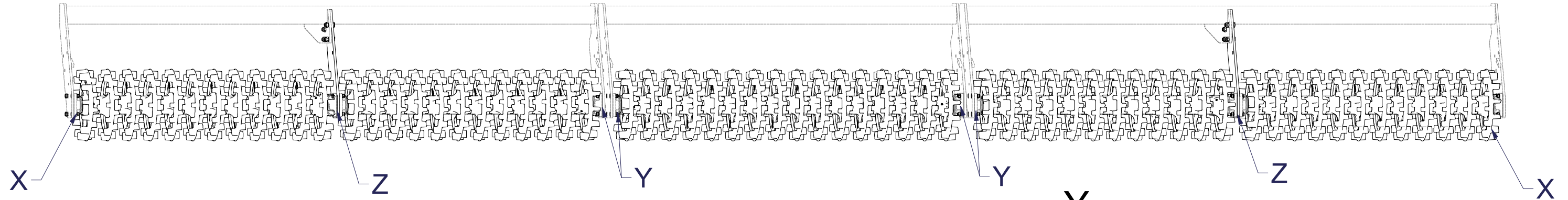

Pos.	Part Number	Pcs.
52	m03519	20
53	m04412	4
54	m05898	8
70	m01305	32
80	m17741	4
81	m03988	32

- ⒸZ SADA ZADNÍCH VÁLČŮ
- Ⓓ SATZ HINTERE WALZEN
- Ⓕ KIT DE ROULEAUX ARRIÈRE

- ⒸB SET OF REAR ROLLERS
- ⒹU КОМПЛЕКТ ЗАДНИХ КАТКОВ
- ⒸL ZESTAW TYLNYCH WAŁÓW



3011920

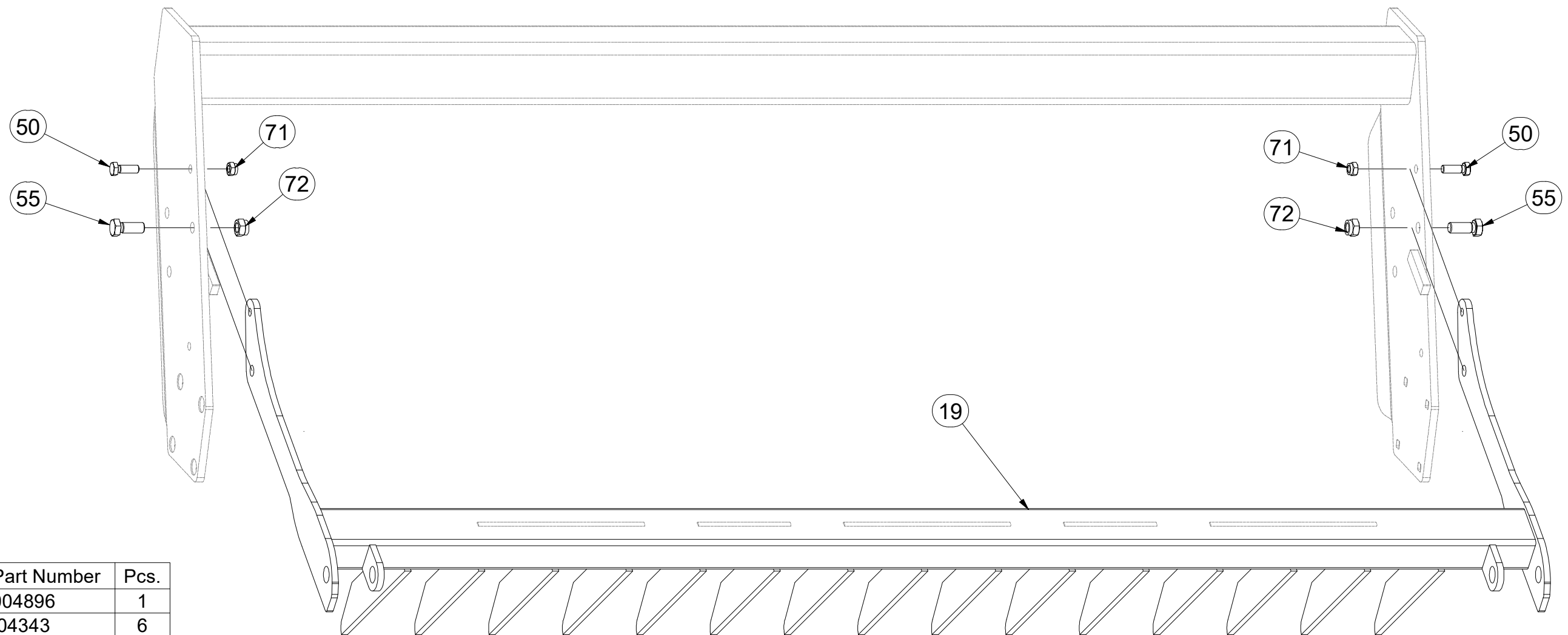
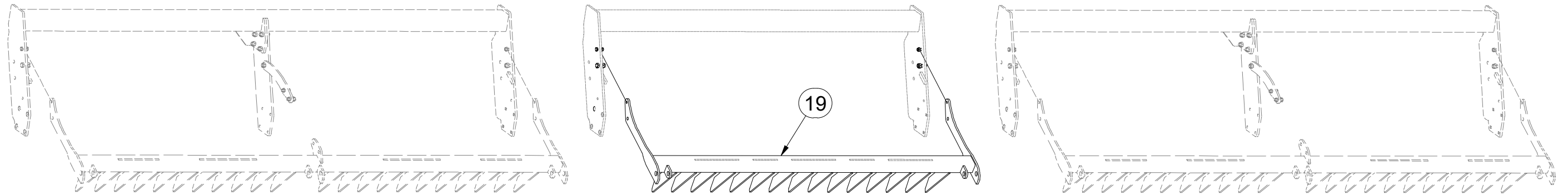

Pos.	Part Number	Pcs.
19	3004896	1
50	m04343	6
55	m01129	8
71	m04301	10
72	m03683	24

CZ SADA ZADNÍCH VÁLČŮ
 D SATZ HINTERE WALZEN
 F KIT DE ROULEAUX ARRIÈRE

GB SET OF REAR ROLLERS
 RU КОМПЛЕКТ ЗАДНИХ КАТКОВ
 PL ZESTAW TYLNYCH WAŁÓW



3011920

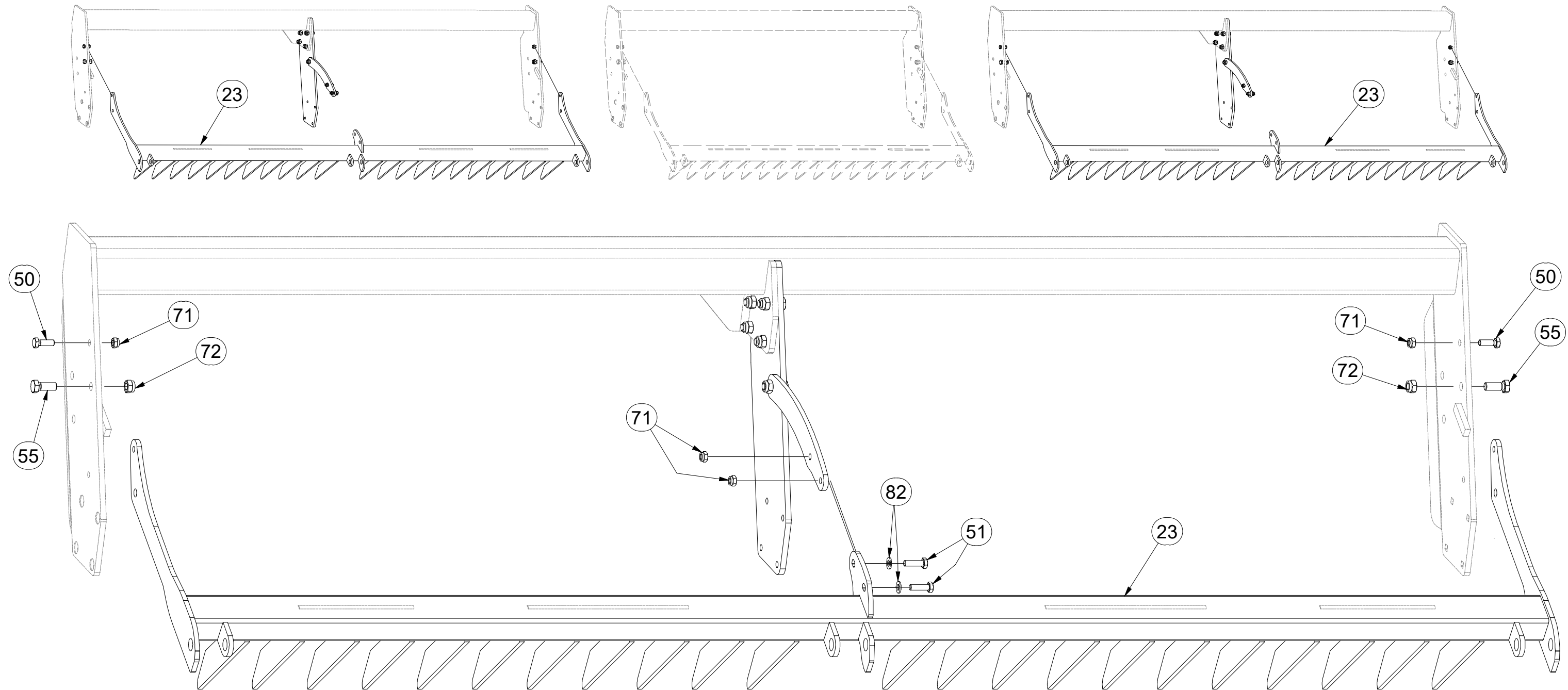

Pos.	Part Number	Pcs.
23	3007383	2
50	m04343	6
51	m03926	4
55	m01129	8
71	m04301	10
72	m03683	24

- Ⓒ SADA ZADNÍCH VÁLČŮ
- Ⓓ SATZ HINTERE WALZEN
- Ⓕ KIT DE ROULEAUX ARRIÈRE

- Ⓖ SET OF REAR ROLLERS
- Ⓡ КОМПЛЕКТ ЗАДНИХ КАТКОВ
- Ⓟ ZESTAW TYLNYCH WAŁÓW



3011920

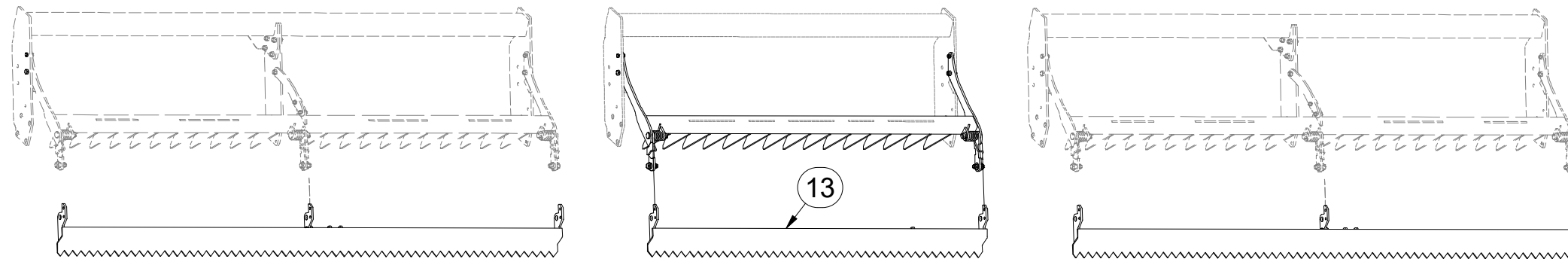

Pos.	Part Number	Pcs.	Pos.	Part Number	Pcs.
13	VZ00018653	1	58	m09464	8
24	4024903	8	59	m04355	8
25	4022223	8	72	m03683	24
29	4015778	8	73	m04503	8
30	9002979	8	83	m05651	16
40	m12303	5	84	m14028	8
41	m12304	3			

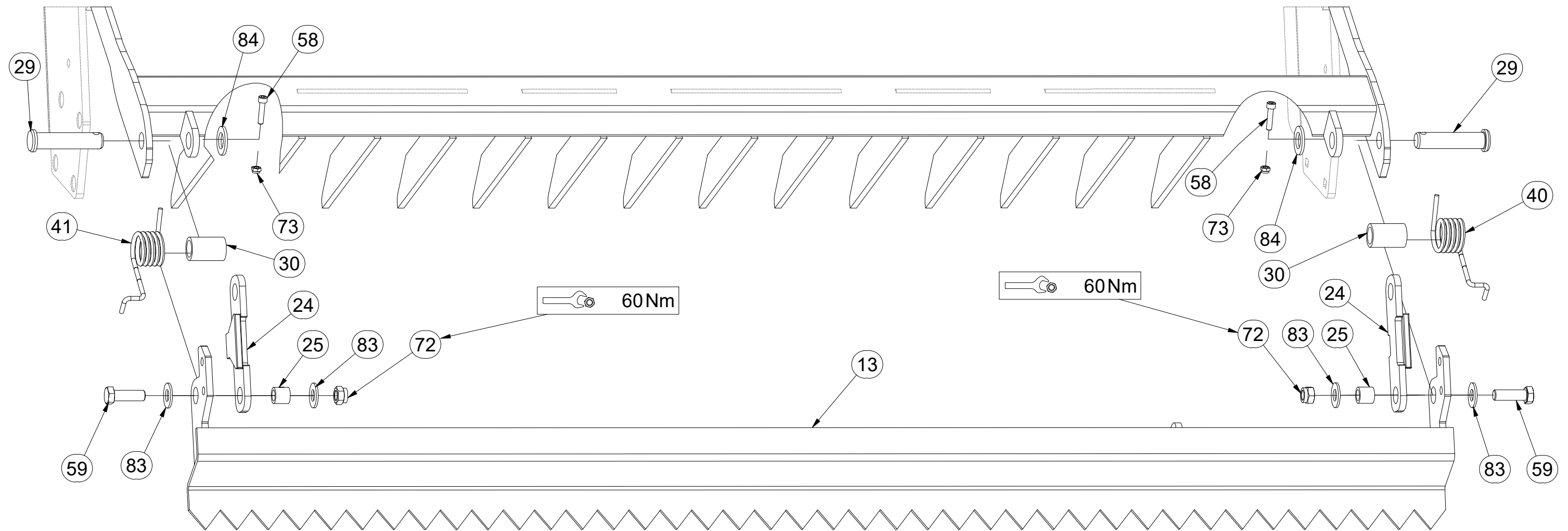

- Ⓒ SADA ZADNÍCH VÁLČŮ
- Ⓓ SATZ HINTERE WALZEN
- Ⓕ KIT DE ROULEAUX ARRIÈRE

- Ⓖ SET OF REAR ROLLERS
- Ⓡ КОМПЛЕКТ ЗАДНИХ КАТКОВ
- Ⓢ ZESTAW TYLNYCH WAŁÓW



3011920

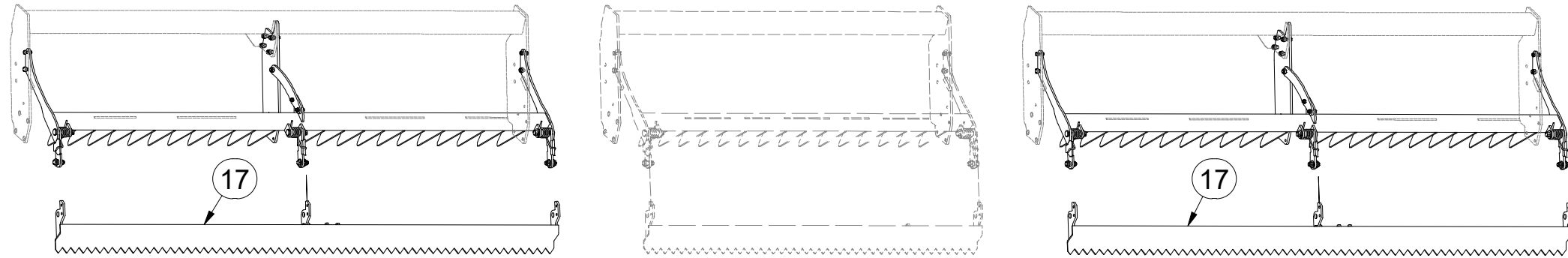

Pos.	Part Number	Pcs.	Pos.	Part Number	Pcs.
17	VZ00019831	2	58	m09464	8
24	4024903	8	59	m04355	8
25	4022223	8	72	m03683	24
29	4015778	8	73	m04503	8
30	9002979	8	83	m05651	16
40	m12303	5	84	m14028	8
41	m12304	3			

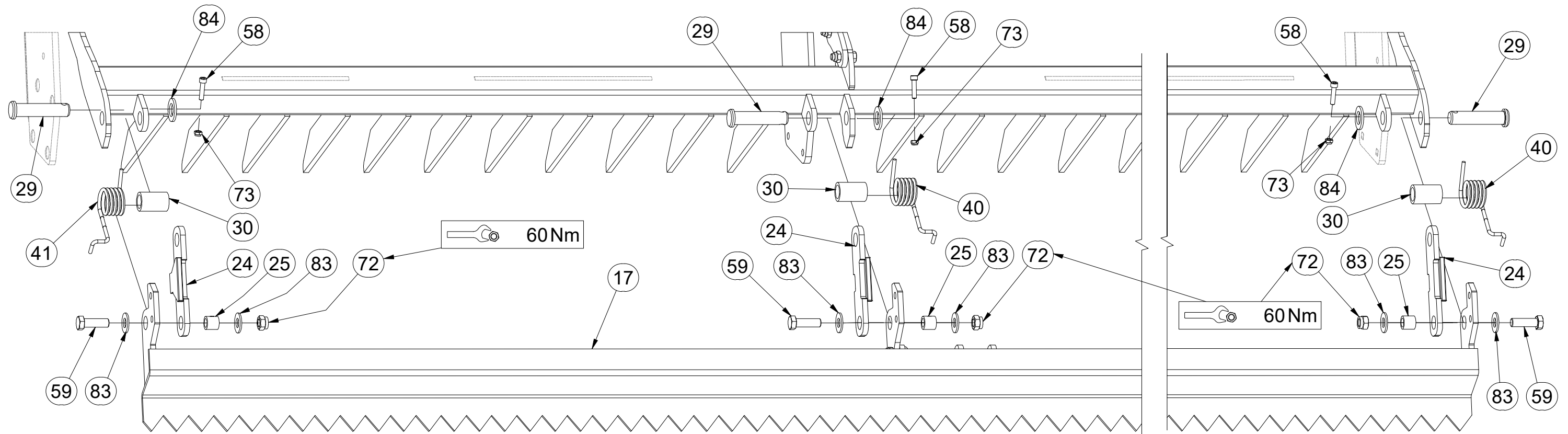

- Ⓒ SADA ZADNÍCH VÁLCŮ
- Ⓓ SATZ HINTERE WALZEN
- Ⓕ KIT DE ROULEAUX ARRIÈRE

- Ⓖ SET OF REAR ROLLERS
- Ⓡ КОМПЛЕКТ ЗАДНИХ КАТКОВ
- Ⓟ ZESTAW TYLNYCH WAŁÓW



3011920

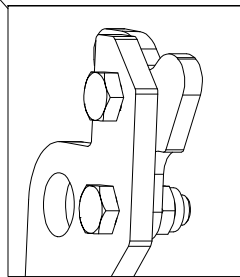
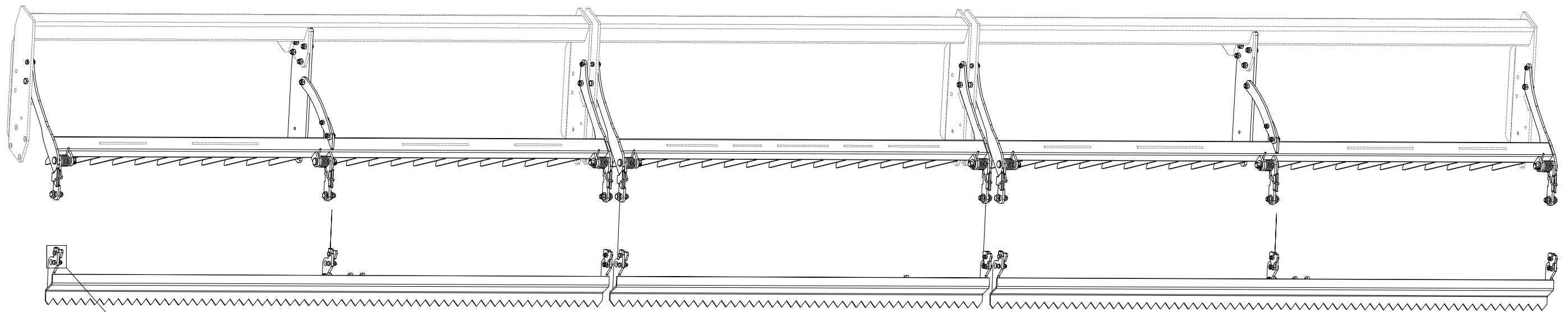

42

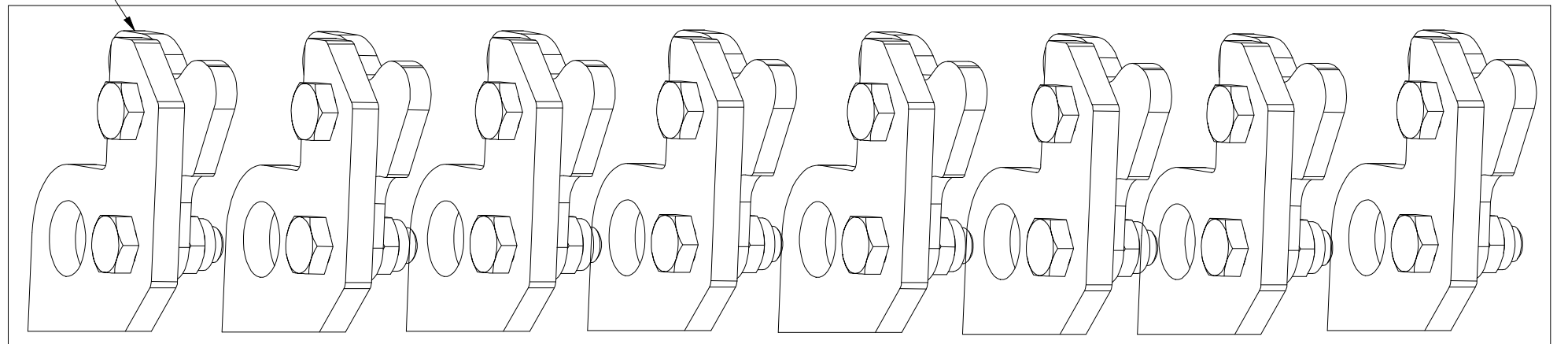

Pos.	Part Number	Pcs.
42	3006131	1

- ⒸZ SADA ZADNÍCH VÁLČŮ
- Ⓓ SATZ HINTERE WALZEN
- Ⓕ KIT DE ROULEAUX ARRIÈRE

- ⒼB SET OF REAR ROLLERS
- ⒶR КОМПЛЕКТ ЗАДНИХ КАТКОВ
- ⒶL ZESTAW TYLNYCH WAŁÓW



3011920

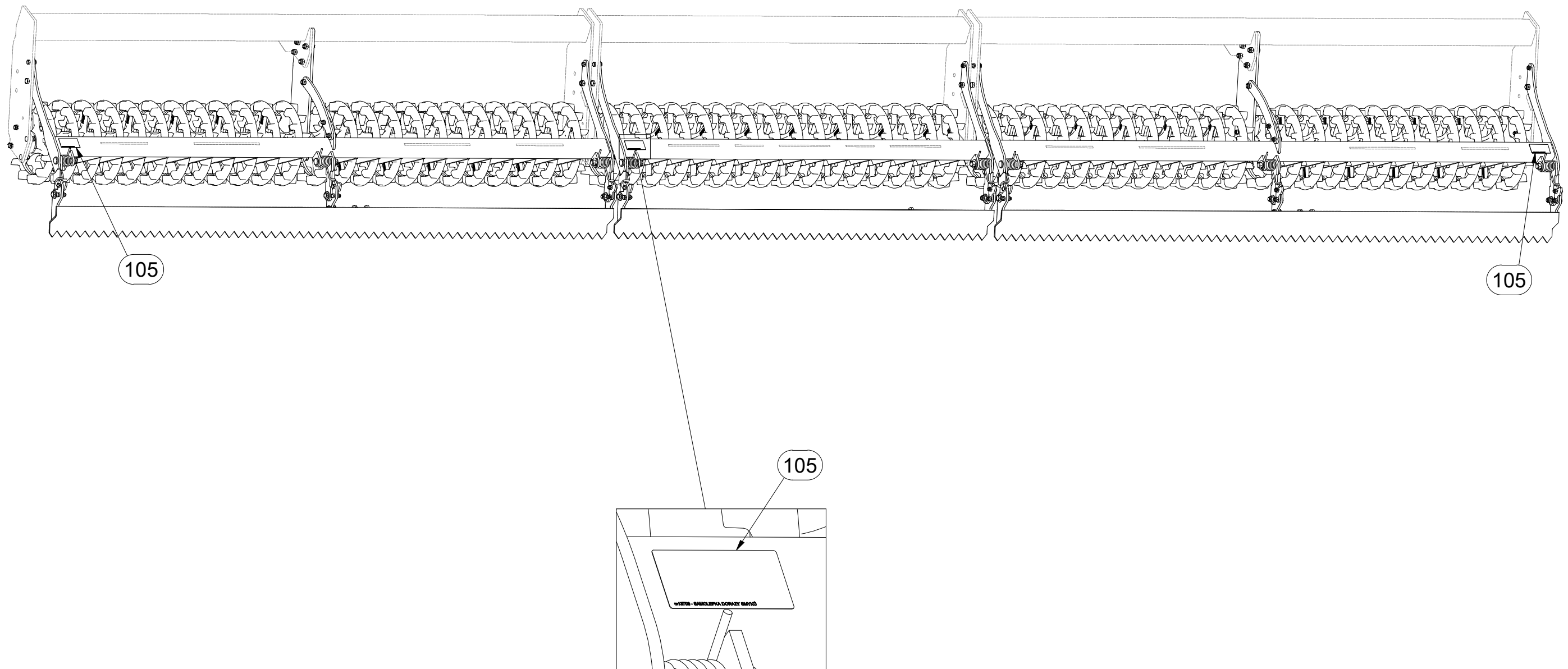

Pos.	Part Number	Pcs.
105	m13708	3

- ⒸZ SADA LOŽISEK
- Ⓓ SATZ LAGER
- Ⓕ KIT DE ROULEMENTS

- ⒸGB SET OF BEARINGS
- ⒸRU КОМПЛЕКТ ПОДШИПНИКОВ
- ⒸPL ZESTAW ŁOŻYSK



VZ00012468

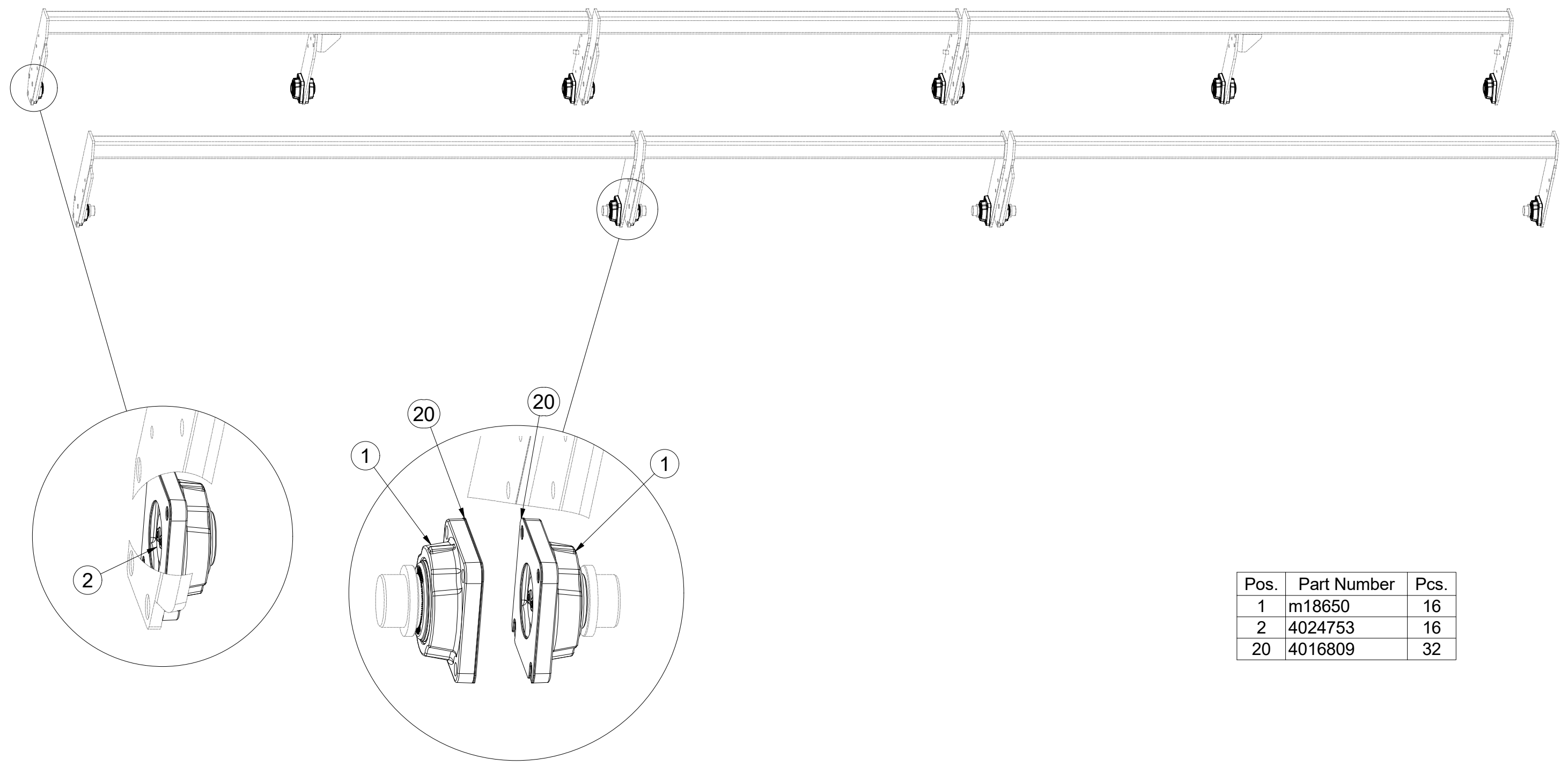

Pos.	Part Number	Pcs.
1	m18650	16
2	4024753	16
20	4016809	32

- ⒸZ SADA LOŽISEK
- Ⓓ SATZ LAGER
- Ⓕ KIT DE ROULEMENTS

- ⒼB SET OF BEARINGS
- ⒺU КОМПЛЕКТ ПОДШИПНИКОВ
- ⒼL ZESTAW ŁOŻYSK



VZ00012468

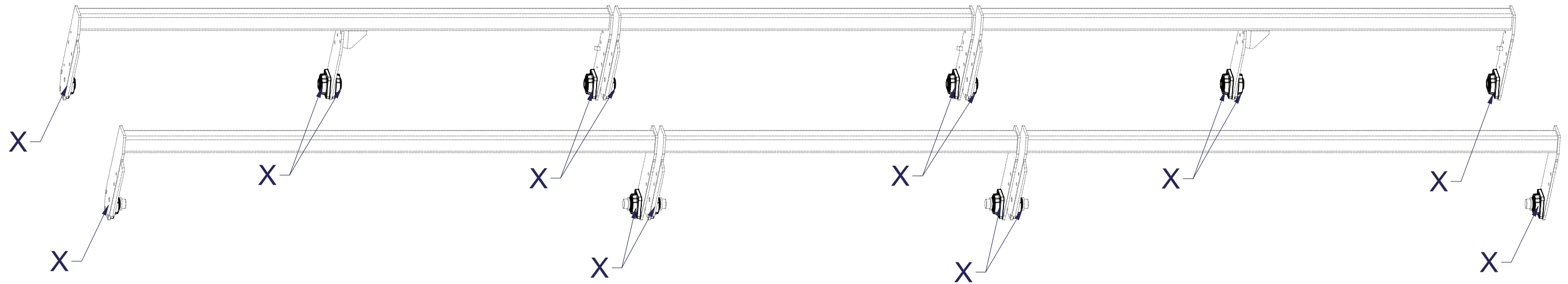

X

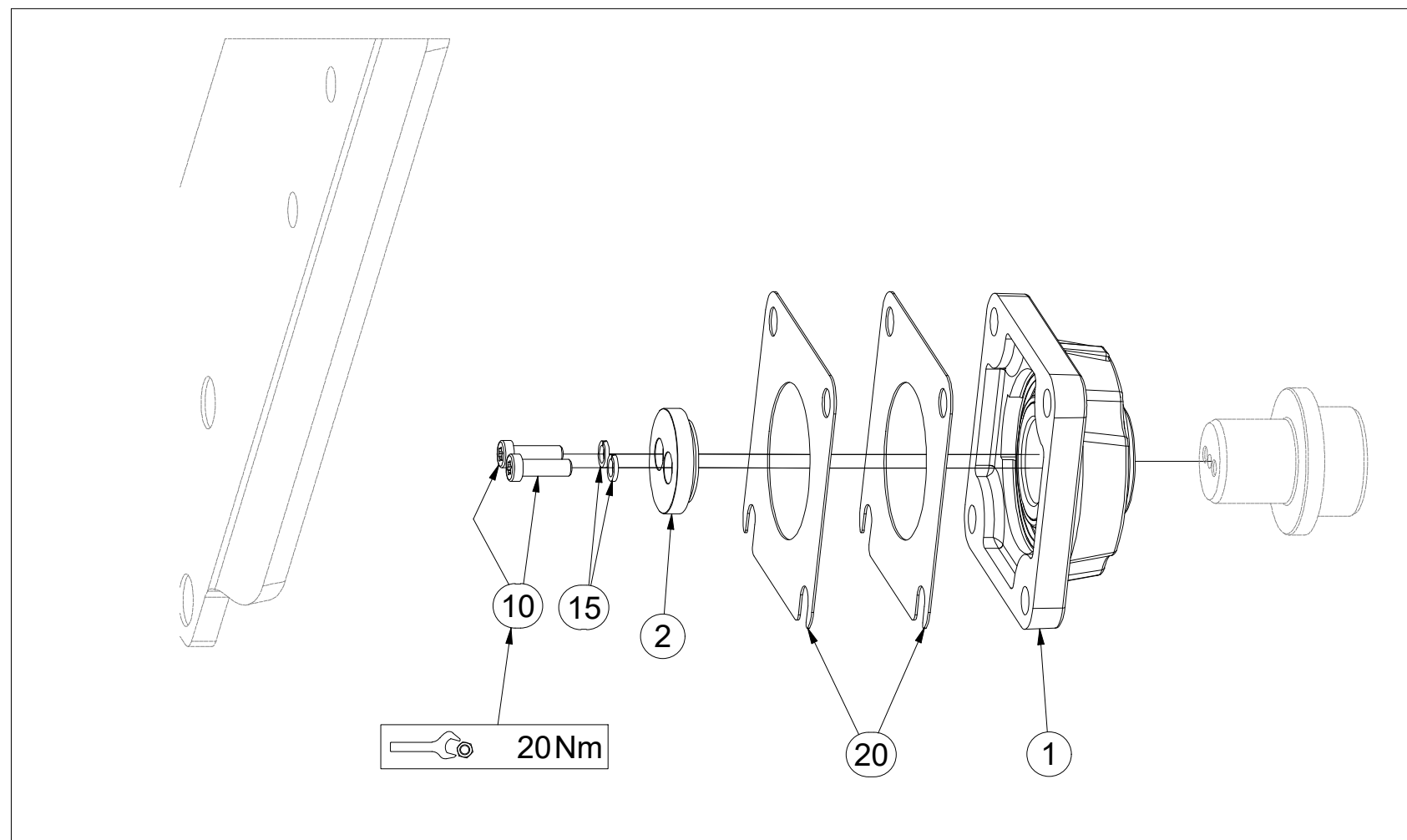

Pos.	Part Number	Pcs.
1	m18650	16
2	4024753	16
15	m01202	32
10	m18858	32
20	4016809	32

ⒸZ SADA DORAZŮ ZADNÍCH SMYKŮ

Ⓓ ANSCHLAGSATZ FÜR HINTERE ACKERSCHLEPPEN

Ⓕ KIT DE BUTÉES DES NIVELEURS ARRIÈRE

3006131

ⒼB SET OF REAR LEVELLING BAR STOPS

ⒺU КОМПЛЕКТ УПОРОВ ЗАДНИХ БОРОН

ⒽL ZESTAW DOCISKÓW TYLNYCH WŁÓK

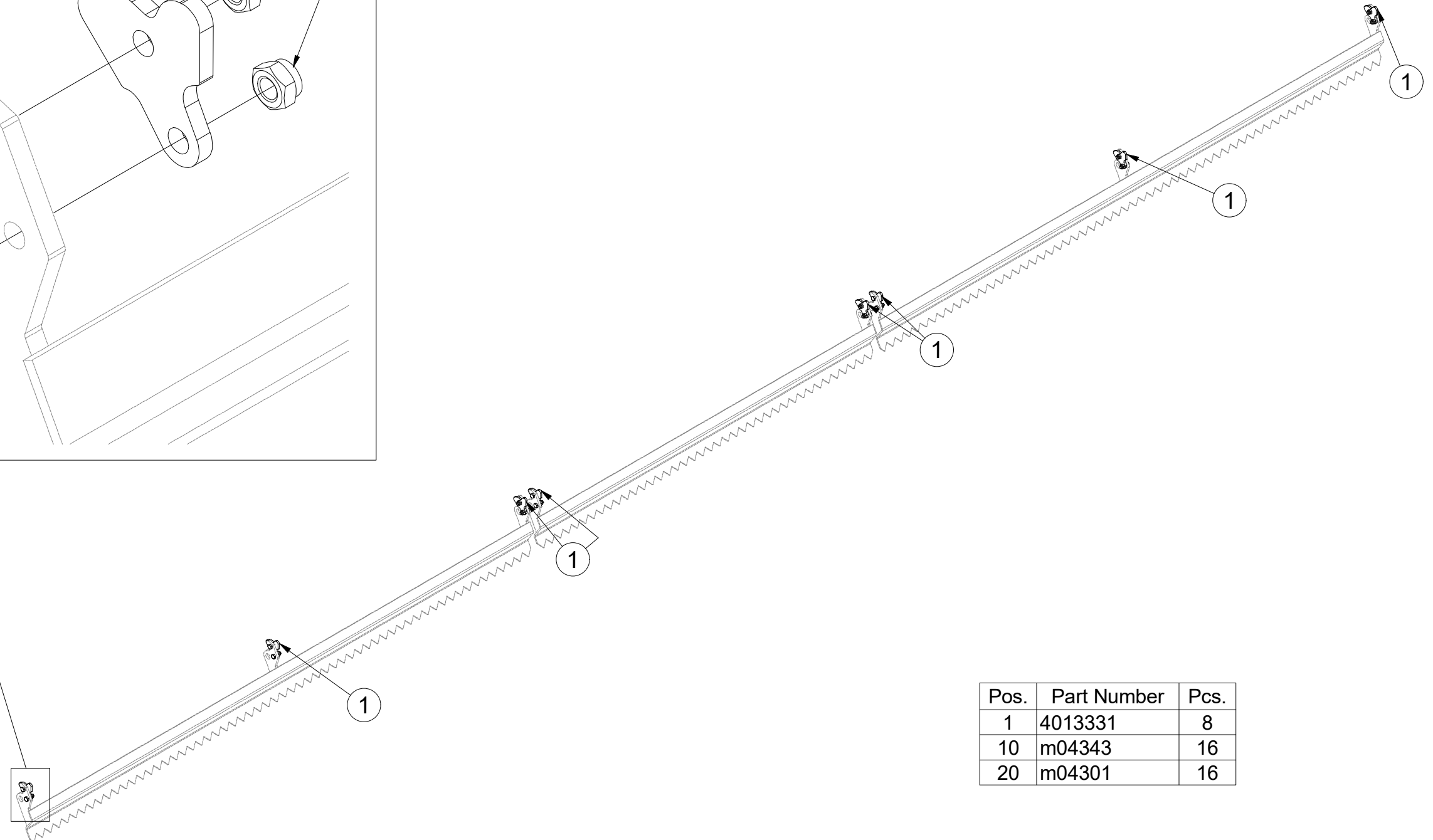
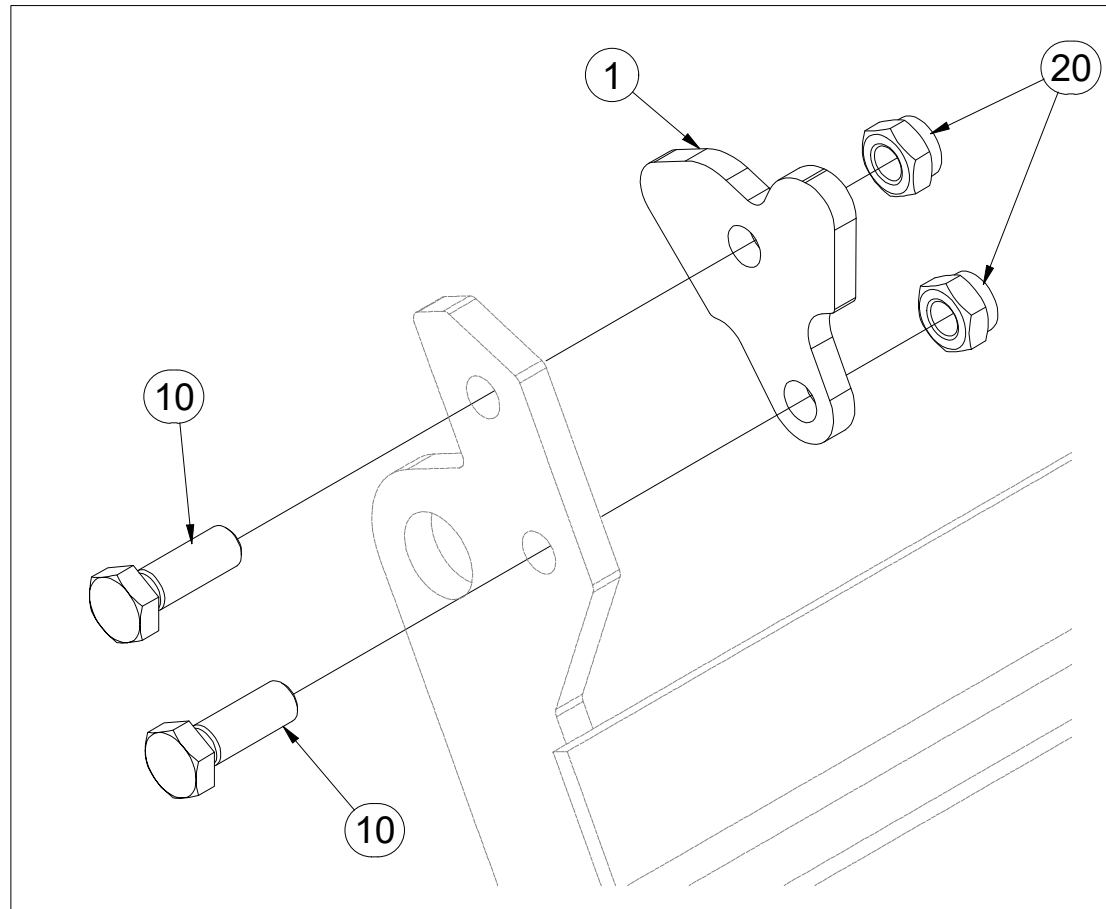

Pos.	Part Number	Pcs.
1	4013331	8
10	m04343	16
20	m04301	16

Ⓒ CZ SADA NÁPRAVY

Ⓓ D SATZ AUFHÄNGUNG

Ⓕ F KIT DE L'ESSIEU

Ⓖ GB AXLE SET

Ⓡ RU КОМПЛЕКТ ОСИ КОЛЁС

Ⓟ PL ZESTAW OSI

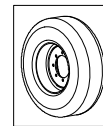

3012633

	M18x1,5-265Nm
	280 kPa

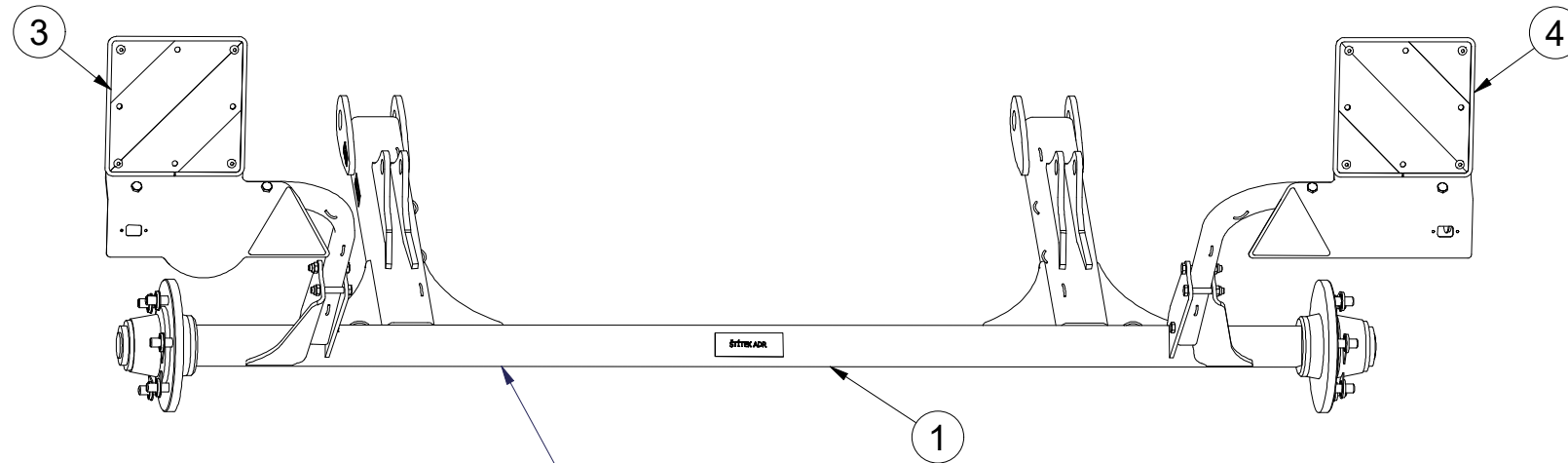

A80RM60

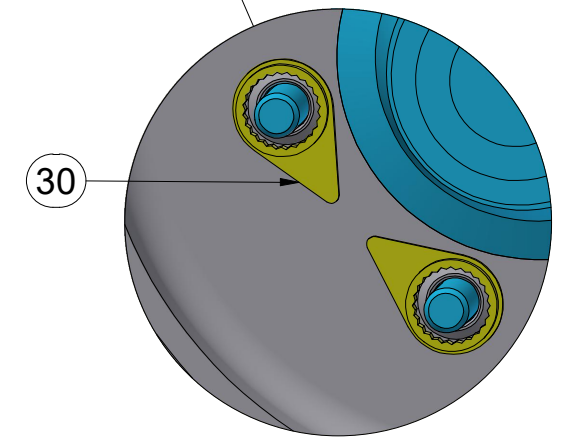
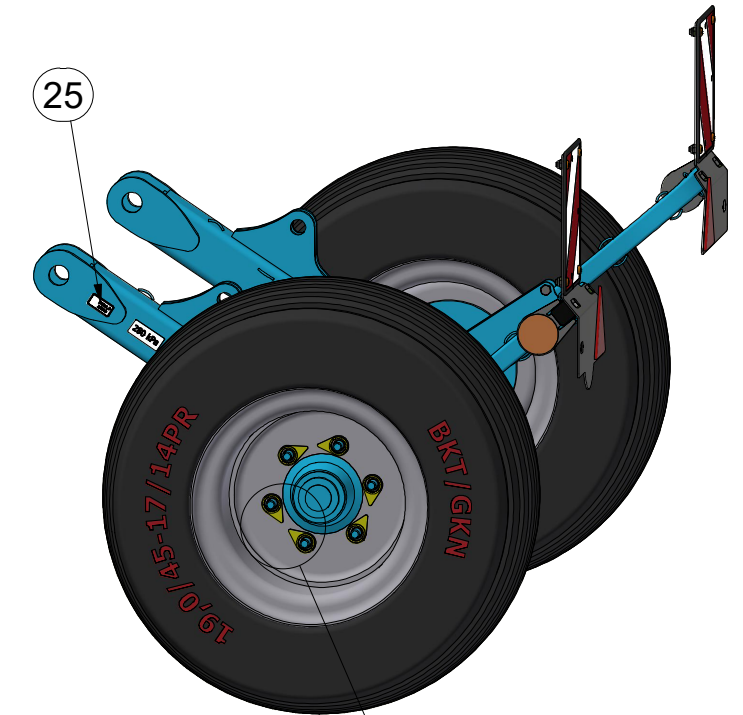
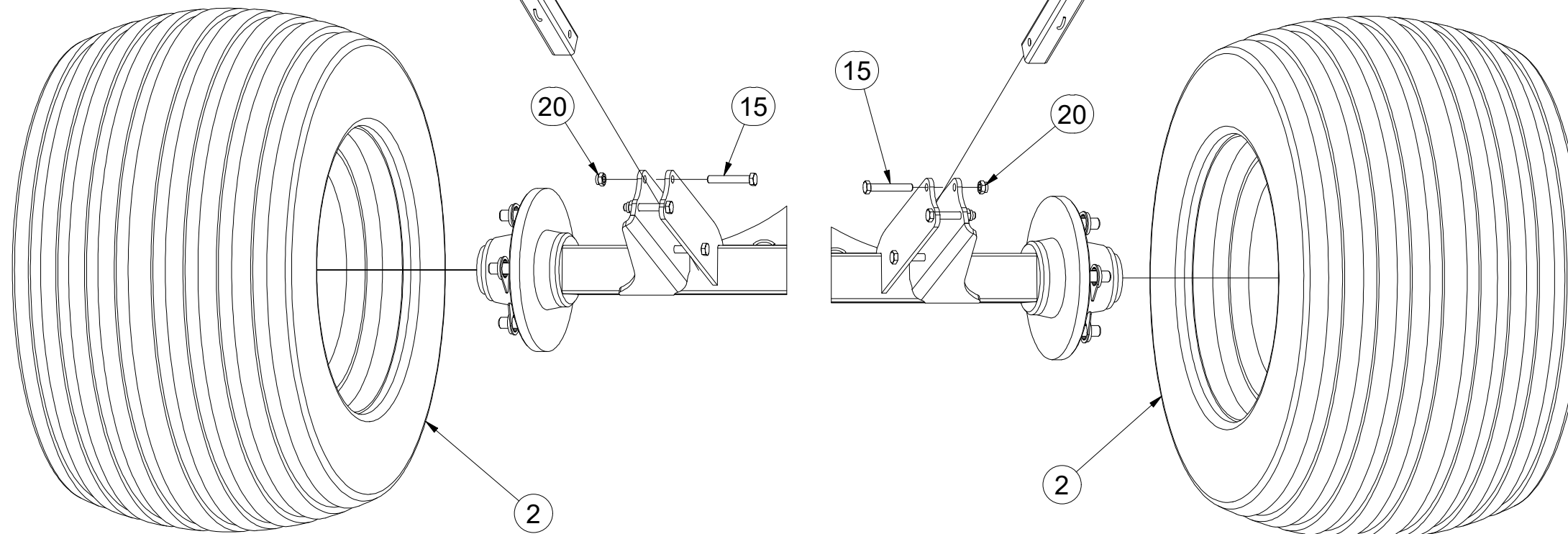

Pos.	Part Number	Pcs.
1	3012632	1
2	m19870	2
3	3012367	1
4	3012389	1
15	m12493	6
20	m04301	6
25	m19732	2
30	m19657	12

Ⓒ NÁPRAVA

Ⓓ ACHSE

Ⓕ ESSIEU

Ⓖ AXLE

Ⓡ OCB

Ⓟ OS



A80RM600

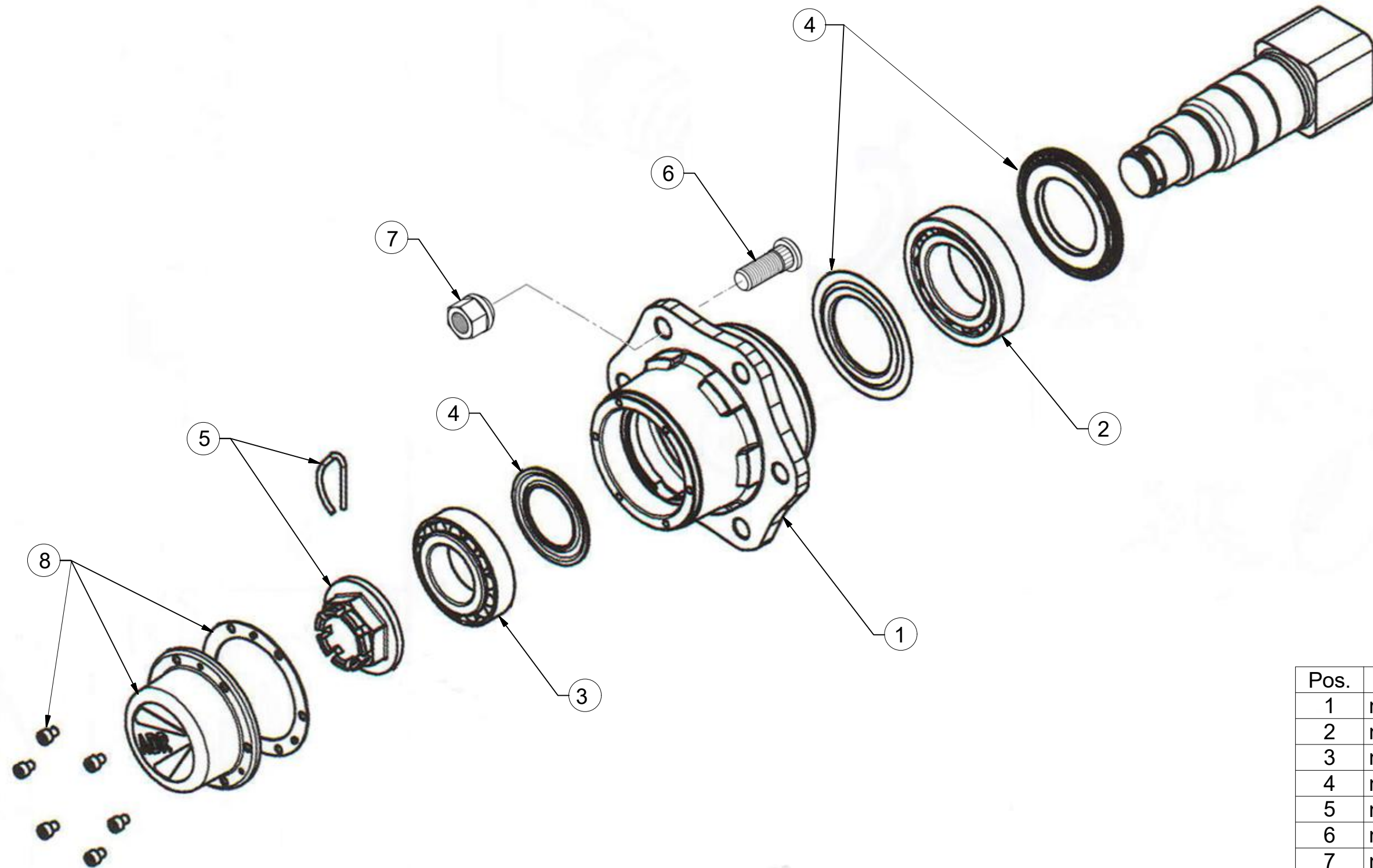

Pos.	Part Number	Pcs.
1	m12567	2
2	m07153	2
3	m07154	2
4	m12565	2
5	m08168	2
6	m08148	12
7	m08163	12
8	m12566	2

ⒸZ TERČ ZADNÍ LEVÝ

Ⓓ SCHILD, HINTERES, LINKES

Ⓕ CIBLE ARRIÈRE GAUCHE

3012367

ⒼB LEFT REAR DISC

ⒺЩИТОК ЗАДНИЙ ЛЕВЫЙ

ⒽL TARCZA TYLNA LEWA

Farmet

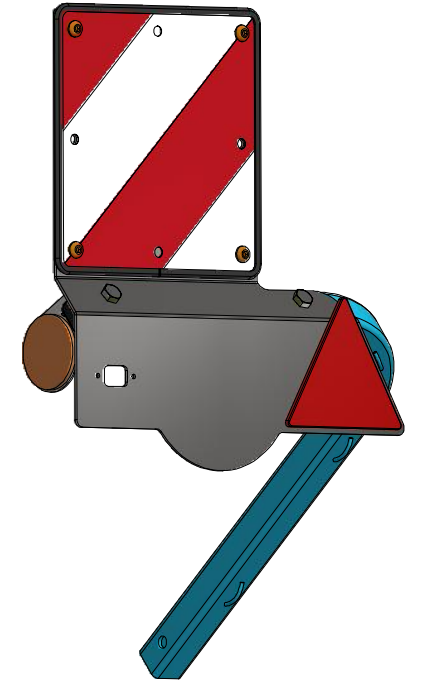
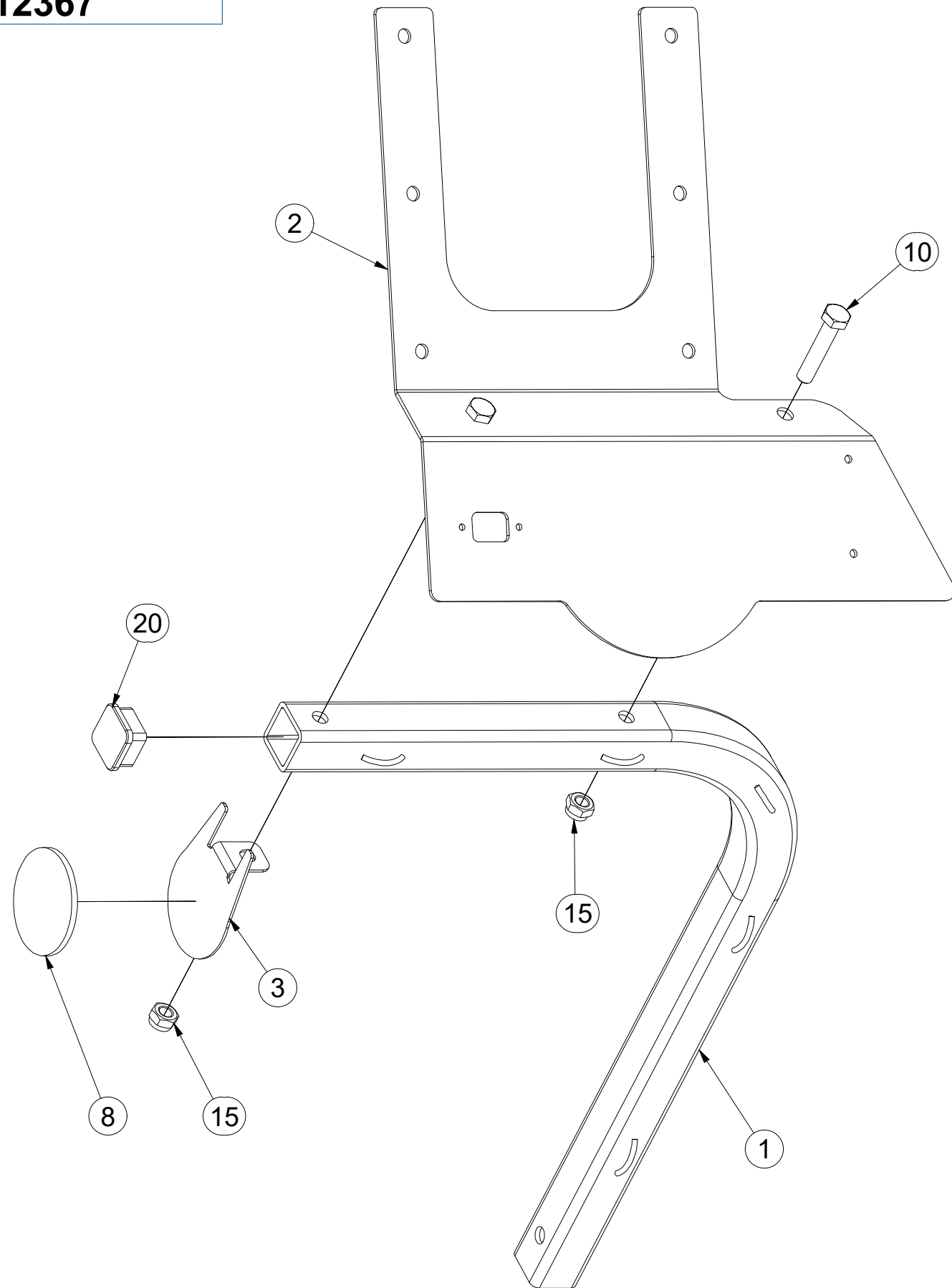

Pos.	Part Number	Pcs.
1	3012364	1
2	3012365	1
3	4024926	1
8	m02579	1
10	m01131	2
15	m04301	2
20	m12689	1

ⒸZ TERČ ZADNÍ LEVÝ

Ⓓ SCHILD, HINTERES, LINKES

Ⓕ CIBLE ARRIÈRE GAUCHE

ⒼB LEFT REAR DISC

ⒶU ЩИТОК ЗАДНИЙ ЛЕВЫЙ

ⒶL TARCZA TYLNA LEWA

Farmet

3012367

Pos.	Part Number	Pcs.
5	m18855	1
6	9005707	1
7	m02497	1
11	m16637	4
16	m03775	4
25	m01209	4

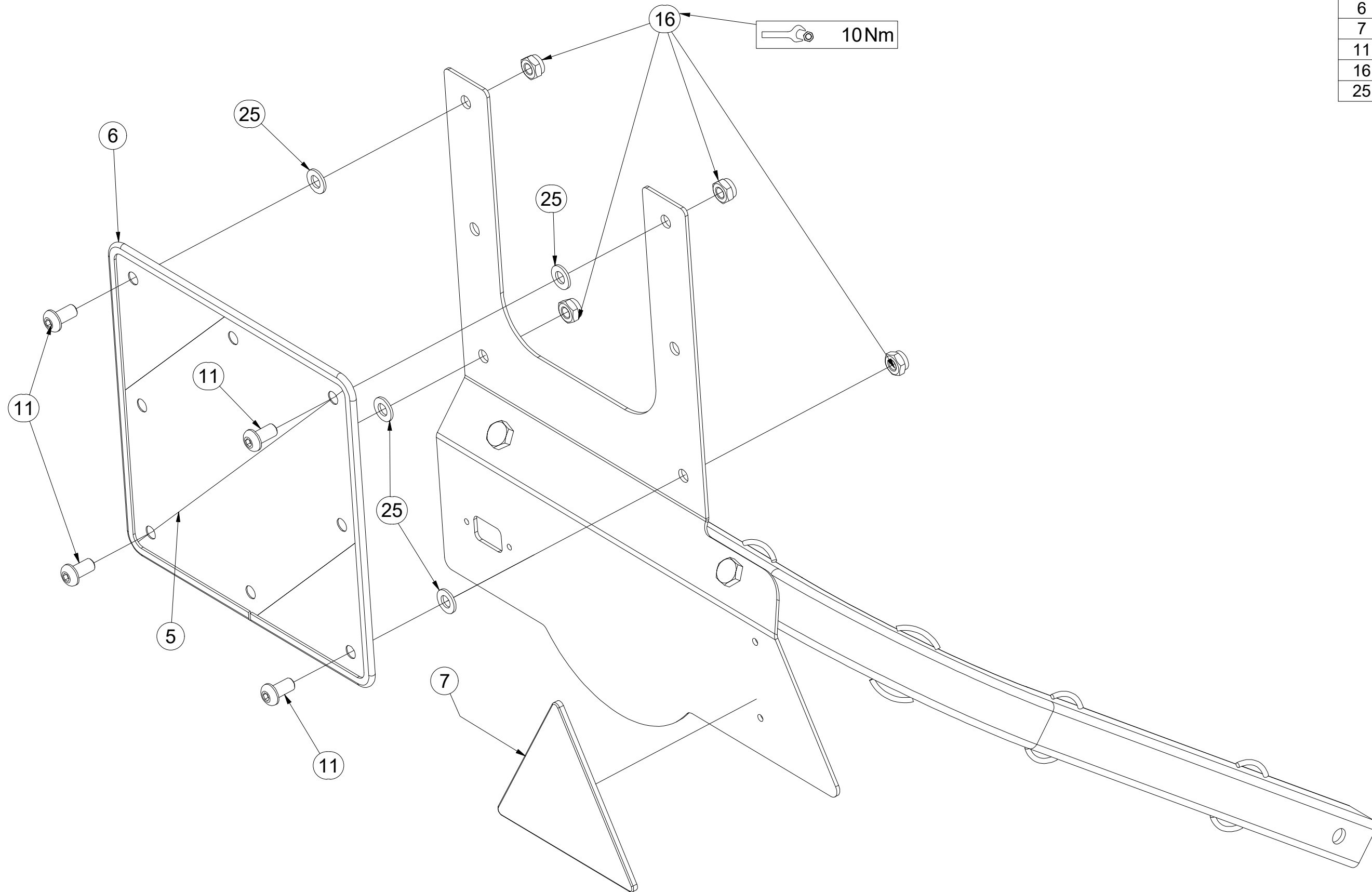

ⒸZ TERČ ZADNÍ PRAVÝ

Ⓓ SCHILD, HINTERES, RECHTES

Ⓕ CIBLE ARRIÈRE DROITE

3012389

ⒼB RIGHT REAR DISC

ⒺЩИТОК ЗАДНИЙ ПРАВЫЙ

ⒽL TARCZA TYLNA PRAWA

Farmet

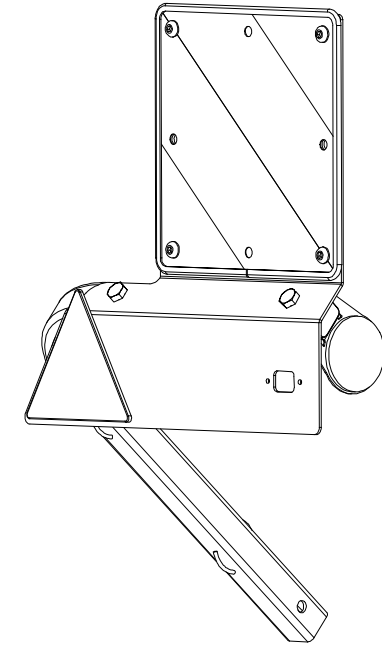
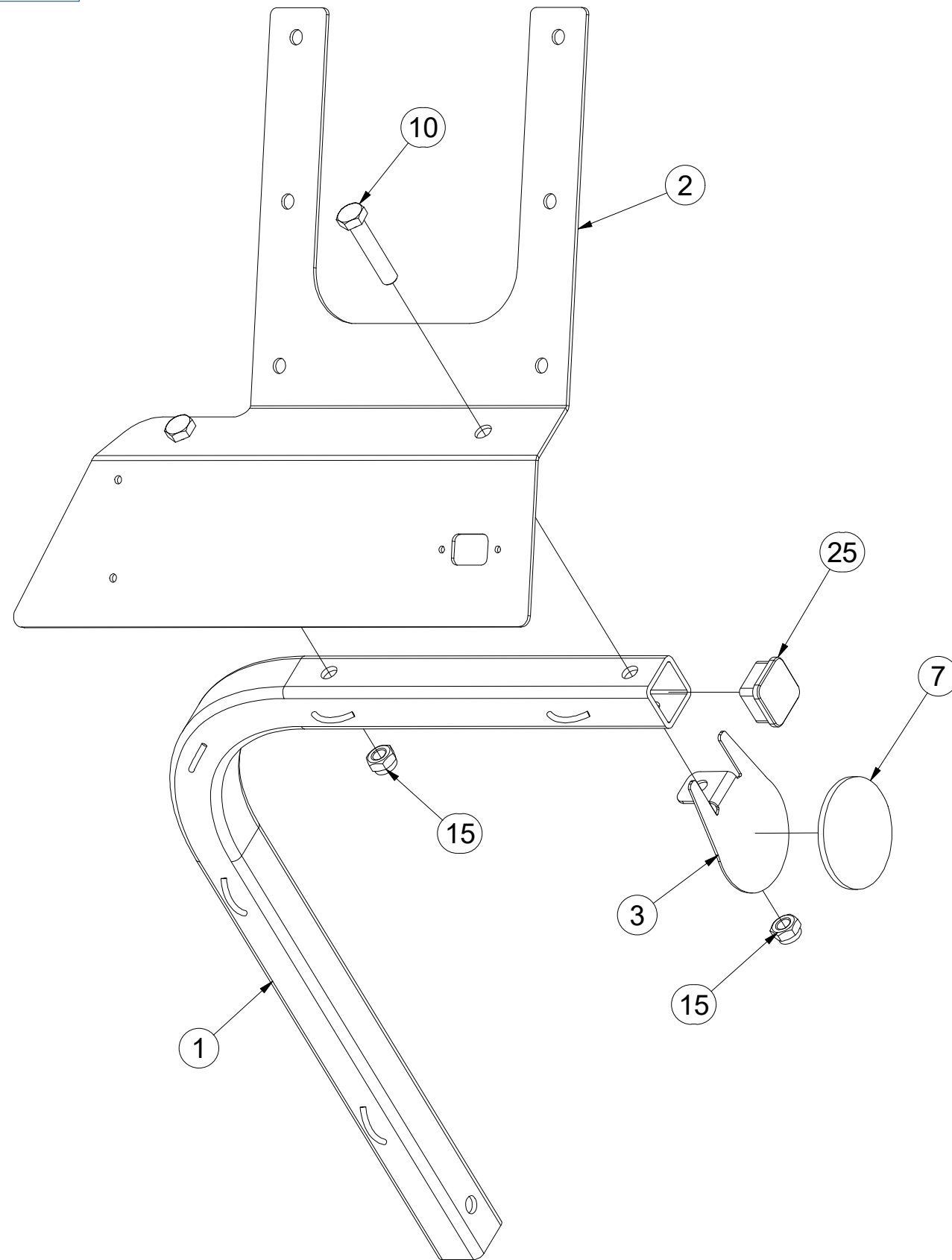

Pos.	Part Number	Pcs.
1	3012364	1
2	3012390	1
3	4024926	1
7	m02579	1
10	m01131	2
15	m04301	2
25	m12689	1

ⒸZ TERČ ZADNÍ PRAVÝ

Ⓓ SCHILD, HINTERES, RECHTES

Ⓕ CIBLE ARRIÈRE DROITE

ⒼB RIGHT REAR DISC

Ⓔ RU ЩИТОК ЗАДНИЙ ПРАВЫЙ

Ⓐ PL TARCZA TYLNA PRAWA

Farmet

3012389

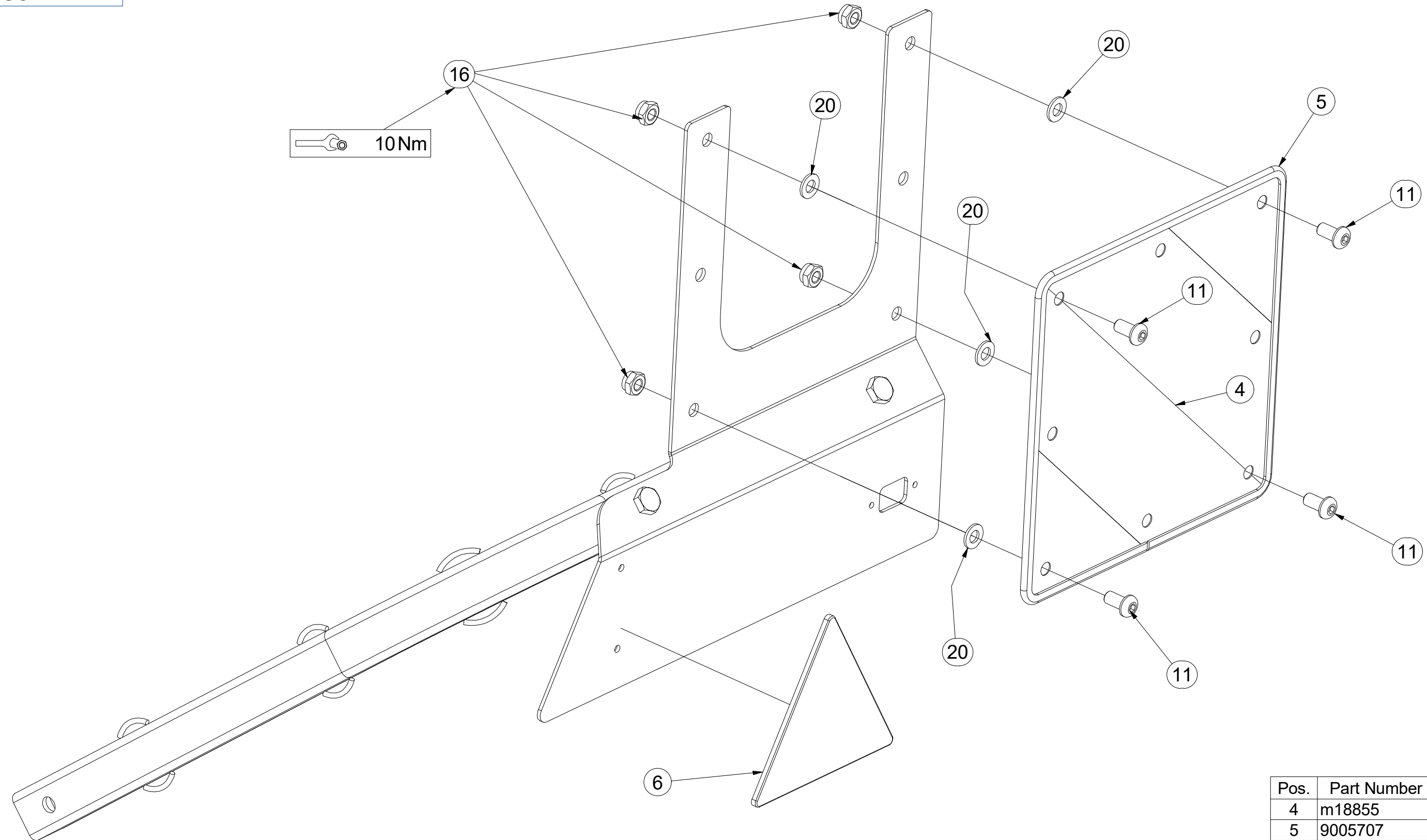

Pos.	Part Number	Pcs.
4	m18855	1
5	9005707	1
6	m02497	1
11	m16637	4
16	m03775	4
20	m01209	4

Ⓒ SAMOLEPKY STROJE

Ⓓ AUFKLEBER MASCHINEN

Ⓕ VOITURE MACHINES

Ⓖ STICKERS MACHINES

Ⓡ СТИКЕРЫ МАШИНЫ

Ⓟ NAKLEJKI MASZYNY



4026236

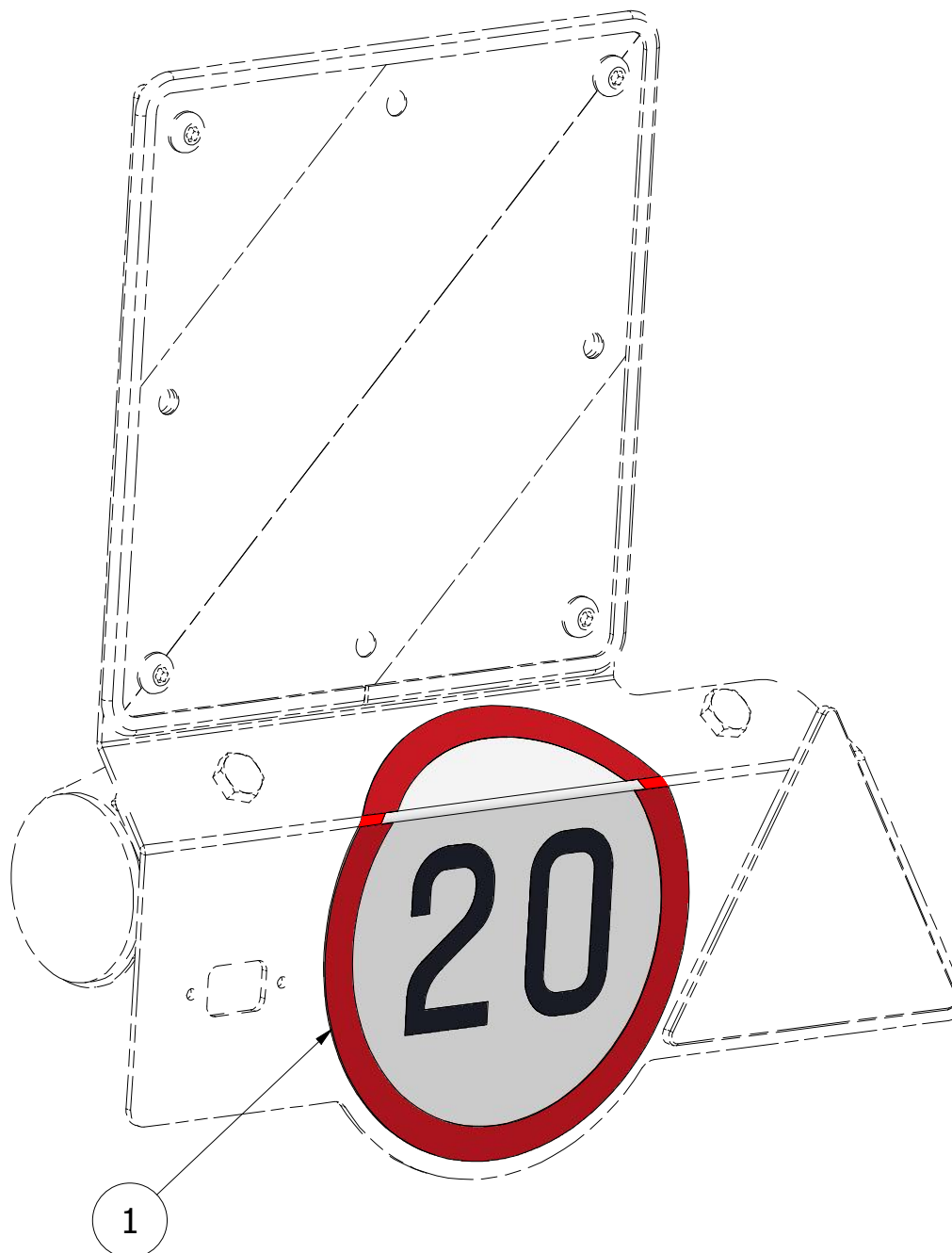

Pos.	Part Number	Pcs.
1	m04406	1

ⒸZ SOUPRAVA TĚSNIVA PÍSTNIC

Ⓓ KOLBENSTANGENDICHTUNGSMITTELSATZ

Ⓕ SET DE GARNITURE DES TIGES DE PISTON

ⒼB SEALING SET FOR PISTON RODS

ⒺRU КОМПЛЕКТ ПРОКЛАДОК ЦИЛИНДРОВ

ⒼL ZESTAW USZCZELEK TRZPIENIA TŁOKA

Farmet

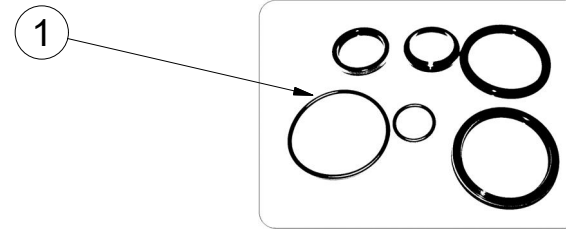
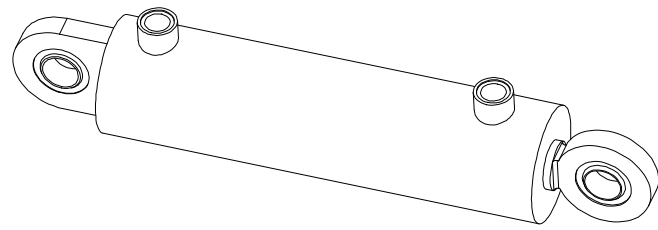

VZ00004549 - Ø80/Ø40-250		
Pos	Part number	Pcs
1	m20702	2

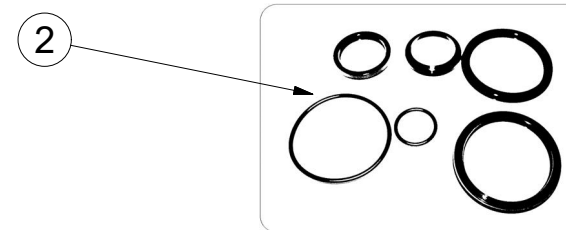
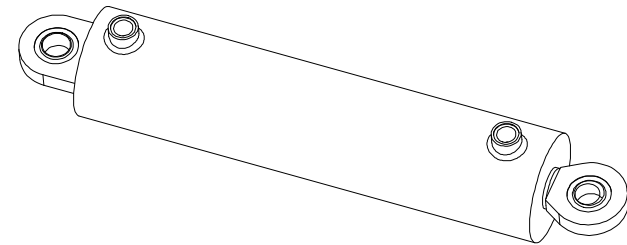

VZ00013004 - Ø100/Ø45-400		
Pos	Part number	Pcs
2	m05504	2

Ⓒ SVĚTELNÁ SADA

Ⓓ LEUCHTENSATZ

Ⓕ KIT LUMINEUX

Ⓖ LIGHTING SET

Ⓡ ОСВЕТИТЕЛЬНЫЙ КОМПЛЕКТ

Ⓟ ZESTAW OŚWIETLENIA



3012429

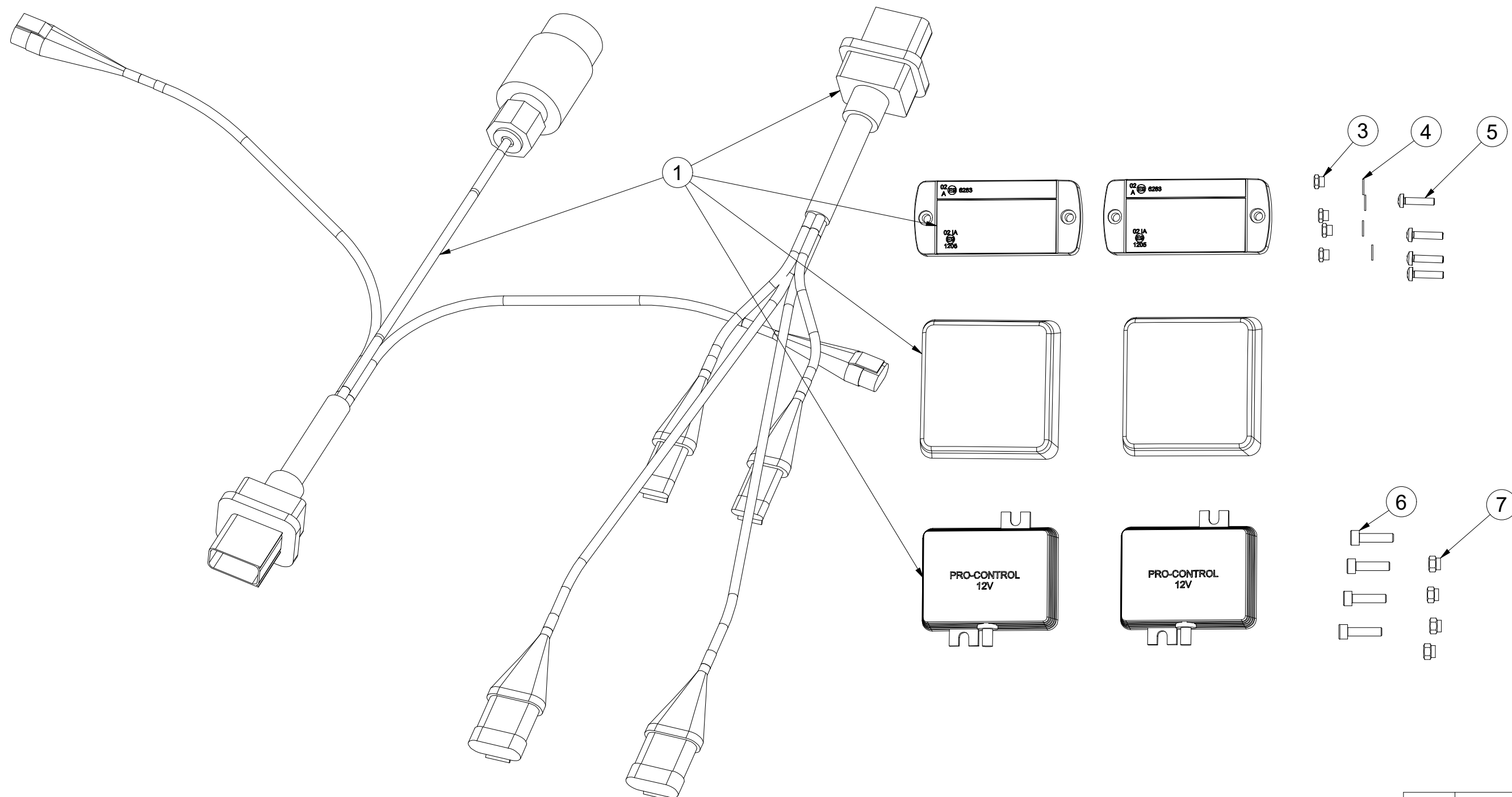

Pos.	Part Number	Pcs.
1	m19043	1
3	m05562	4
4	m05597	4
5	m15790	4
6	m10591	4
7	m06236	4

Ⓒ SVĚTELNÁ SADA

Ⓓ LEUCHTENSATZ

Ⓕ KIT LUMINEUX

Ⓖ LIGHTING SET

Ⓡ ОСВЕТИТЕЛЬНЫЙ КОМПЛЕКТ

Ⓟ ZESTAW OŚWIETLENIA



3012429

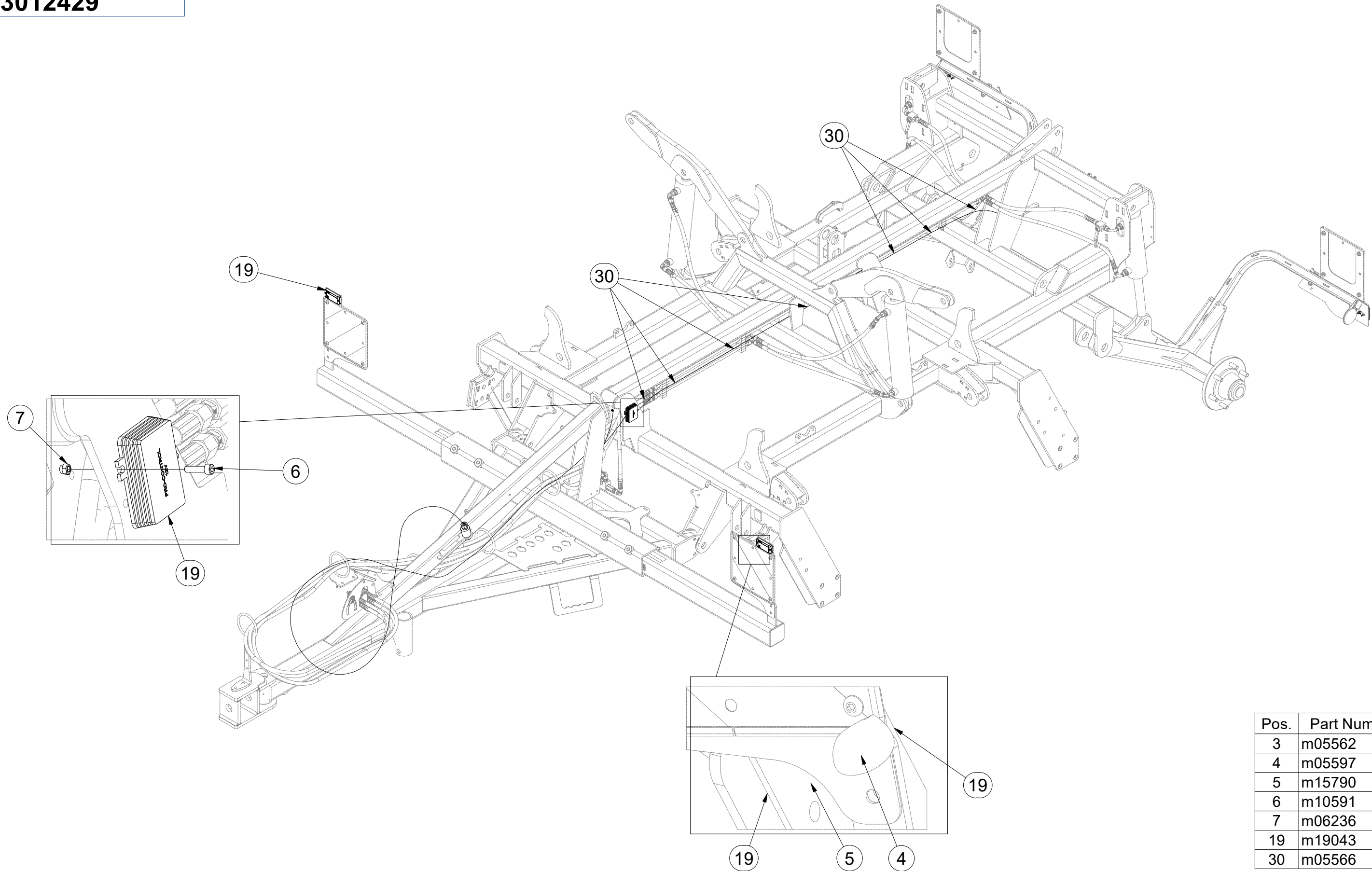

Pos.	Part Number	Pcs.
3	m05562	4
4	m05597	4
5	m15790	4
6	m10591	4
7	m06236	4
19	m19043	1
30	m05566	50

Ⓒ SVĚTELNÁ SADA

Ⓓ LEUCHTENSATZ

Ⓕ KIT LUMINEUX

Ⓖ LIGHTING SET

Ⓔ ОСВЕТИТЕЛЬНЫЙ КОМПЛЕКТ

Ⓗ ZESTAW OŚWIETLENIA

Farmet

3012429

Pos.	Part Number	Pcs.
19	m19043	1
30	m05566	50

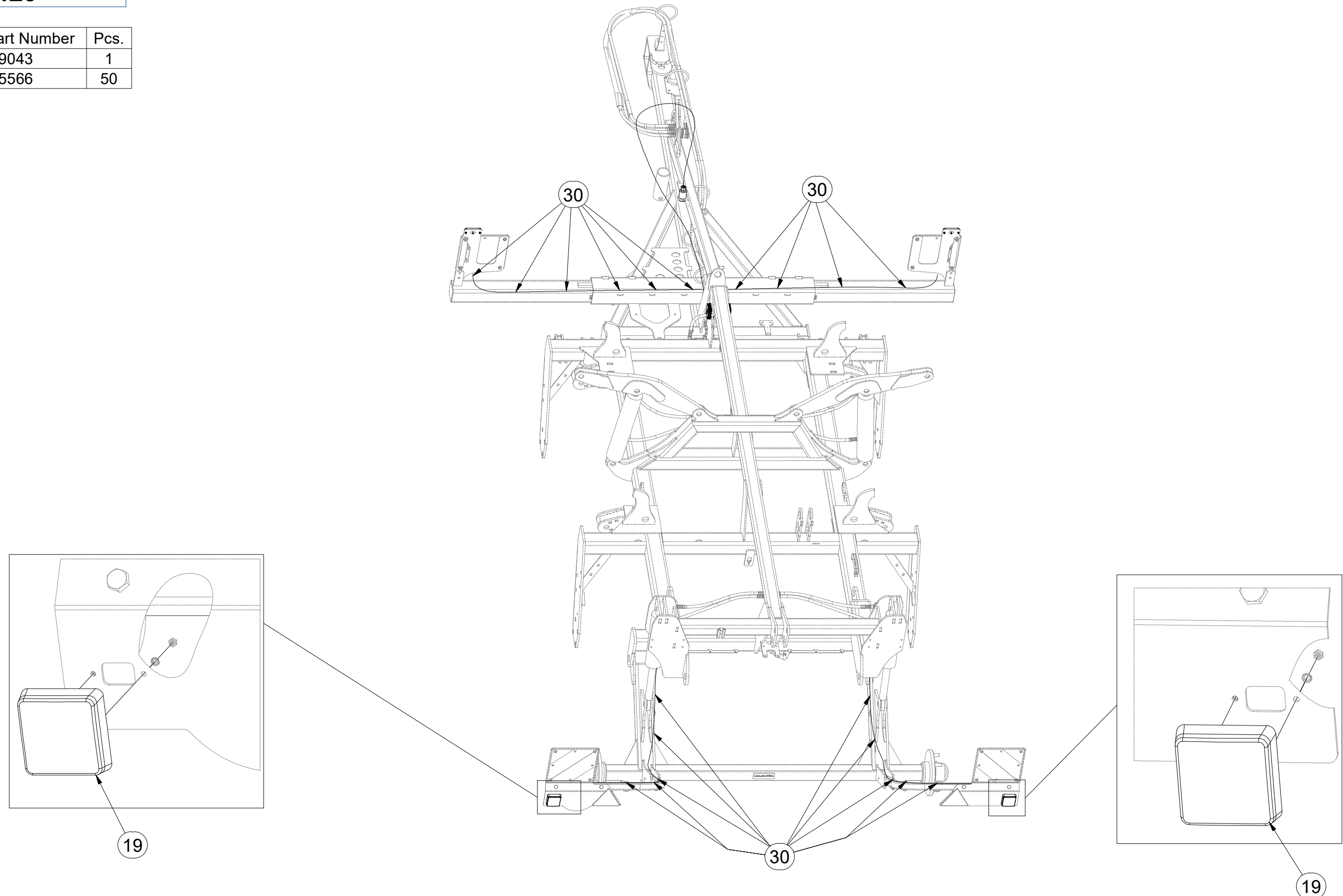

Ⓒ SVĚTELNÁ SADA

Ⓓ LEUCHTENSATZ

Ⓕ KIT LUMINEUX

m19043

Ⓖ LIGHTING SET

Ⓡ ОСВЕТИТЕЛЬНЫЙ КОМПЛЕКТ

Ⓟ ZESTAW OŚWIETLENIA

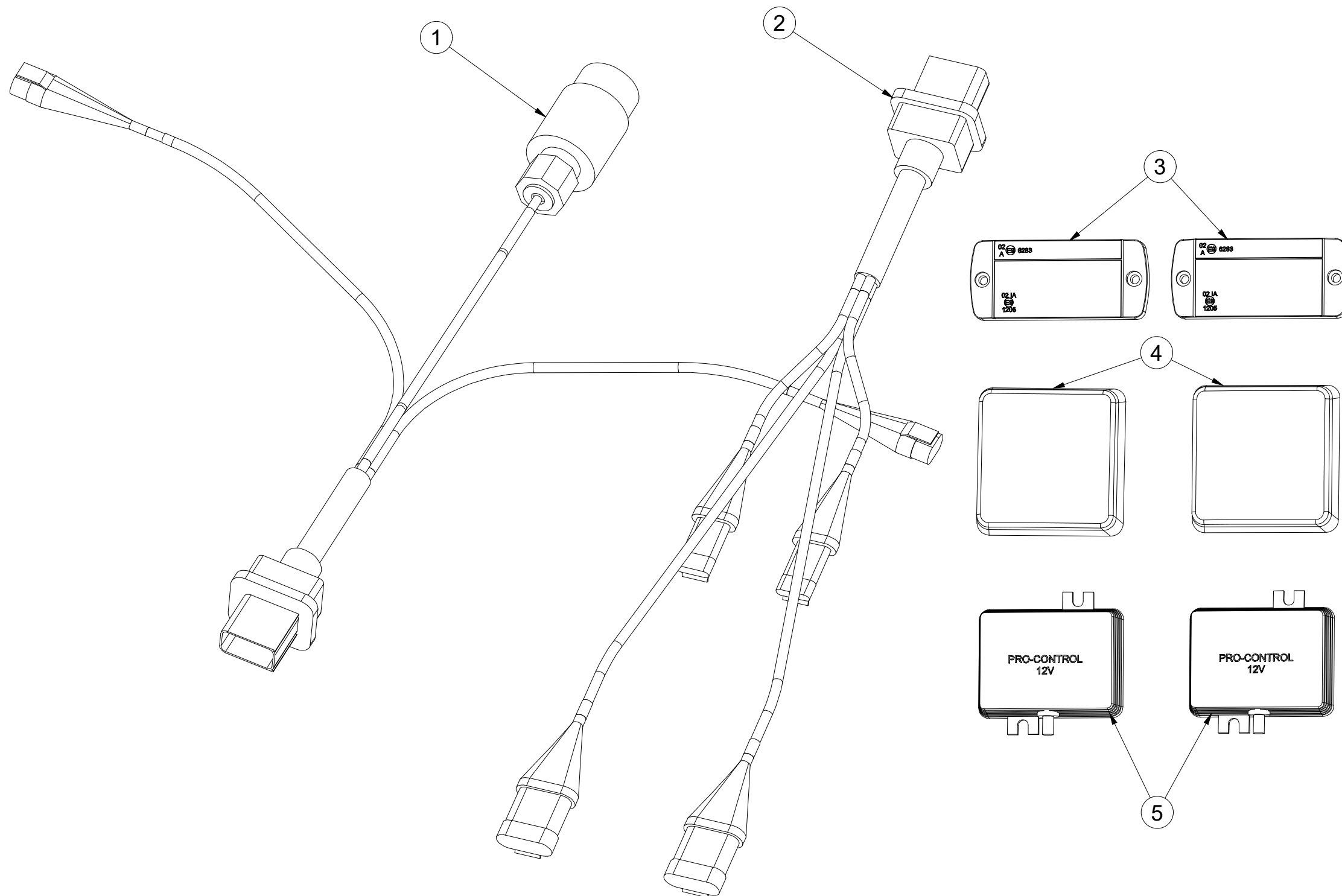

Pos.	Part Number	Pcs.
1	m14779	1
2	m14778	1
3	m14776	2
4	m19044	2
5	m14777	2

- Ⓒ UTAHOVACÍ MOMENTY ŠROUBŮ
 Ⓓ ANZUGMOMENTE VON SCHRAUBEN
 Ⓕ COUPLES DE SERRAGE DES VIS

- Ⓒ SCREW TIGHTENING TORQUE
 Ⓓ МОМЕНТЫ ЗАЖАТИЯ БОЛТОВ
 Ⓕ MOMENTY DOKRĘCANIA ŚRUB



P		5.8	8.8	10.9	12.9	Z	
D	R	Mu	Mu	Mu	Mu	DIN 7991	ISO 10642
mm	mm	Nm	Nm	Nm	Nm	Nm	Nm
M6	1	6	9	13	15	7,2	7,9
M8	1,25	14	22	32	38	17	19
M10	1,5	29	44	64	75	35	38
M12	1,75	49	76	111	130	58	65
M14	2	79	120	176	206	93	100
M16	2	123	188	276	323	144	158
M18	2,5	169	257	378	443	-	220
M20	2,5	239	365	536	628	-	310
M22	2,5	329	529	738	864	-	420
M24	3	413	629	924	1082	-	530
M27	3	613	934	1372	1606	-	-
M30	3,5	832	1267	1862	2179	-	-
M33	3,5	1130	1723	2530	2961	-	-
M36	4	1451	2210	3246	3799	-	-
M39	4	1885	2872	4217	4936	-	-
M42	4,5	2322	3538	5196	6080	-	-
M45	4,5	2909	4433	6511	7619	-	-
M48	5	3513	535	7862	9200	-	-
M52	5	4524	6895	10123	11849	-	-
M56	5,5	5636	8589	12614	14761	-	-

- Mu - Ⓒ UTAHOVACÍ MOMENT
 Ⓓ ANZUGMOMENTE
 Ⓕ COUPLE DE SERRAGE
 Ⓒ TIGHTENING TORQUE
 Ⓓ МОМЕНТ ЗАЖАТИЯ
 Ⓕ MOMENT DOKRĘCANIA
- D - Ⓒ JMENOVITÝ PRŮMĚR
 Ⓓ NENNDURCHMESSER
 Ⓕ DIAMETRE NOMINAL
 Ⓒ NOMINAL DIAMETER
 Ⓓ НОМИНАЛЬНЫЙ ДИАМЕТР
 Ⓕ ŚREDNICA NOMINALNA
- R - Ⓒ ROZTEČ ZÁVITU - STOUPÁNÍ
 Ⓓ GEWINDESTEIFUNG
 Ⓕ PAS DE FILET - PAS
 Ⓒ SCREW PITCH – LEAD
 Ⓓ ШАГ РЕЗЬБЫ
 Ⓕ ROZSTAW GWINTU - SKOKI
- P - Ⓒ PEVNOST
 Ⓓ FESTIGKEIT
 Ⓕ RÉSISTANCE
 Ⓒ STRENGTH
 Ⓓ ПРОЧНОСТЬ
 Ⓕ WYTRZYMA OŚĆ
- Z - Ⓒ ZÁPUSTNÉ ŠROUBY
 Ⓓ SENKKOPFSCHRAUBEN
 Ⓕ VIS A TETE FRAISEE
 Ⓒ COUNTERSUNK SCREWS
 Ⓓ БОЛТЫ С УТОПЛЕННОЙ ГОЛОВКОЙ
 Ⓕ ŚRUBY Z ŁBEM STOŻKOWYM PŁASKIM

- Ⓒ Hodnoty momentů jsou poníženy o -10% oproti tabulkovým hodnotám. Šroubové spoje utahujte dle vyznačeného utahovacího momentu v dokumentaci. Pokud není utahovací moment v dokumentaci vyznačen, utahujte dle obecné tabulky. Pokud je v dokumentaci definován spoj šroubu a matice o různých pevnostech, vždy utahujte na moment komponenty nižší.
- Ⓓ Die Werte der Anzugsmomente sind um 10 % gegenüber den Tabellenwerten verringert. Ziehen Sie die Schraubverbindungen gemäß dem in der Dokumentation festgeschriebenen Anzugsmoment an. Sofern das Anzugsmoment nicht in der Dokumentation aufgeführt ist, ziehen Sie sie gemäß der allgemeinen Tabelle an. Wenn in der Dokumentation eine Verbindung von Schraube und Mutter mit verschiedene Festigkeiten definiert ist, wird immer mit dem Moment des Bauteils mit der geringeren Festigkeit angezogen.
- Ⓕ Les valeurs des couples de serrage sont baissées de 10% par rapport aux valeurs de tableau. Serrez les raccords à vis selon le couple de serrage indiqué dans les documents. Si le couple de serrage n'est pas indiqué dans les documents, serrez selon le tableau général. Si les documents définissent un assemblage par boulon de diverses résistances, serrez toujours au moment de la composante avec résistance inférieure.
- Ⓒ The torque values are reduced by 10% compared to the table values. Tighten the screw joints according to the tightening torque stated in the documentation. If the tightening torque is not stated in the documentation, tighten according to the general table. If there is a joint with a screw and a nut at different strengths in the documentation, always tighten to the torque of the component with lower strength.
- Ⓓ Значения моментов затяжки уменьшены на 10% по сравнению с данными в таблице. Резьбовые соединения зажимайте с установленным в документации моментом зажатия. Если в документации не указан момент зажатия, то зажимайте по действующей в общем таблице. Если в документации установлено соединение из болта и гайки различной прочности, всегда зажимайте с моментом для компонента с меньшей прочностью.
- Ⓕ Wartości momentów dokręcania są obniżone o 10% w stosunku do wartości z tabeli. Połączenia śrubowe należy dokręcać zgodnie z momentem obrotowym w dokumentacji. Jeśli w dokumentacji nie ma podanego momentu obrotowego, należy dokręcać zgodnie z ogólną tabelą. Jeśli w dokumentacji zdefiniowane jest połączenie ze śrubą nakrętką różnych wytrzymałościach, zawsze należy dokręcać zachowując moment dokręcania komponentu z niższą wytrzymałością.

- Ⓒ UTAHOVACÍ MOMENTY ŠROUBŮ
 Ⓓ ANZUGMOMENTE VON SCHRAUBEN
 Ⓕ COUPLES DE SERRAGE DES VIS

- Ⓖ SCREW TIGHTENING TORQUE
 Ⓡ МОМЕНТЫ ЗАЖАТИЯ БОЛТОВ
 Ⓟ MOMENTY DOKRĘCANIA ŚRUB



- Ⓒ **OBECNÝ PŘEDPIS UTAHOVÁNÍ ZAJIŠTĚNÍ ČEPOVÝCH SPOJŮ:**
 Ⓓ **ALLGEMEINE VORSCHRIFT FÜR DAS ANZIEHEN VON BOLZENVERBINDUNGEN:**
 Ⓕ **CONSIGNE GENERALE POUR LE SERRAGE DES ARTICULATIONS CYLINDRIQUES:**
 Ⓖ **GENERAL INSTRUCTION FOR TIGHTENING THE SECURING OF PIN JOINTS:**
 Ⓡ **ОБЩЕЕ ОПИСАНИЕ ЗАЖАТИЯ ПРЕДОХРАНЕНИЯ СОЕДИНЕНИЙ ПАЛЬЦАМИ:**
 Ⓟ **OGÓLNE ZASADY DOKRĘCANIA ZABEZPIECZENIA POŁĄCZEŃ CZOPEM:**



X

M8, M10, M12

M14

M

09-15Nm

15-25Nm

- X - Ⓒ ROZMĚR ŠROUBU
 Ⓓ SCHRAUBENGRÖSSE
 Ⓕ DIMENSIONS DE LA VIS

- Ⓖ BOLT DIMENSION
 Ⓡ РАЗМЕР БОЛТА
 Ⓟ ROZMIAR ŚRUBY

- M - Ⓒ ORIENTAČNÍ MOMENT
 Ⓓ ANZUGSMOMENT
 Ⓕ COUPLE D'ORIENTATION

- Ⓖ ORIENTATION TORQUE
 Ⓡ ОРИЕНТАЦИОННЫЙ МОМЕНТ
 Ⓟ ORIENTACYJNY MOMENT

- Ⓒ Tyto spoje není nutné ověřovat kontrolou momentovým klíčem = stačí vizuálně kontrolovat sešroubování.
 Ⓓ Diese Verbindungen müssen nicht mit einem Drehmomentschlüssel überprüft werden = es genügt, die Verschraubung visuell zu kontrollieren.
 Ⓕ Il n'est pas nécessaire de contrôler le serrage à l'aide d'une clé dynamométrique = un contrôle visuel de l'assemblage suffit.
 Ⓖ These joints do not have to be verified by checking with a torque wrench = visual inspection of bolting is sufficient.
 Ⓡ Эти соединения не нужно контролировать динамометрическим ключом = достаточно визуально проверять прикручивание.
 Ⓟ Nie trzeba sprawdzać tych połączeń kluczem dynamometrycznym = wystarczy wizualnie skontrolować dokręcenie.