

The effective technology

Farmet®

ⒸZ KATALOG NÁHRADNÍCH DÍLŮ ⒸB CATALOGUE OF SPARE PARTS ⒸD ERSATZTEILLISTE
ⒸRU КАТАЛОГ ЗАПАСНЫХ ЧАСТЕЙ ⒸF CATALOGUE DES PIÈCES DE RECHANGE ⒸPL KATALOG CZĘŚCI ZAMIENNYCH

VERSO 8 PS

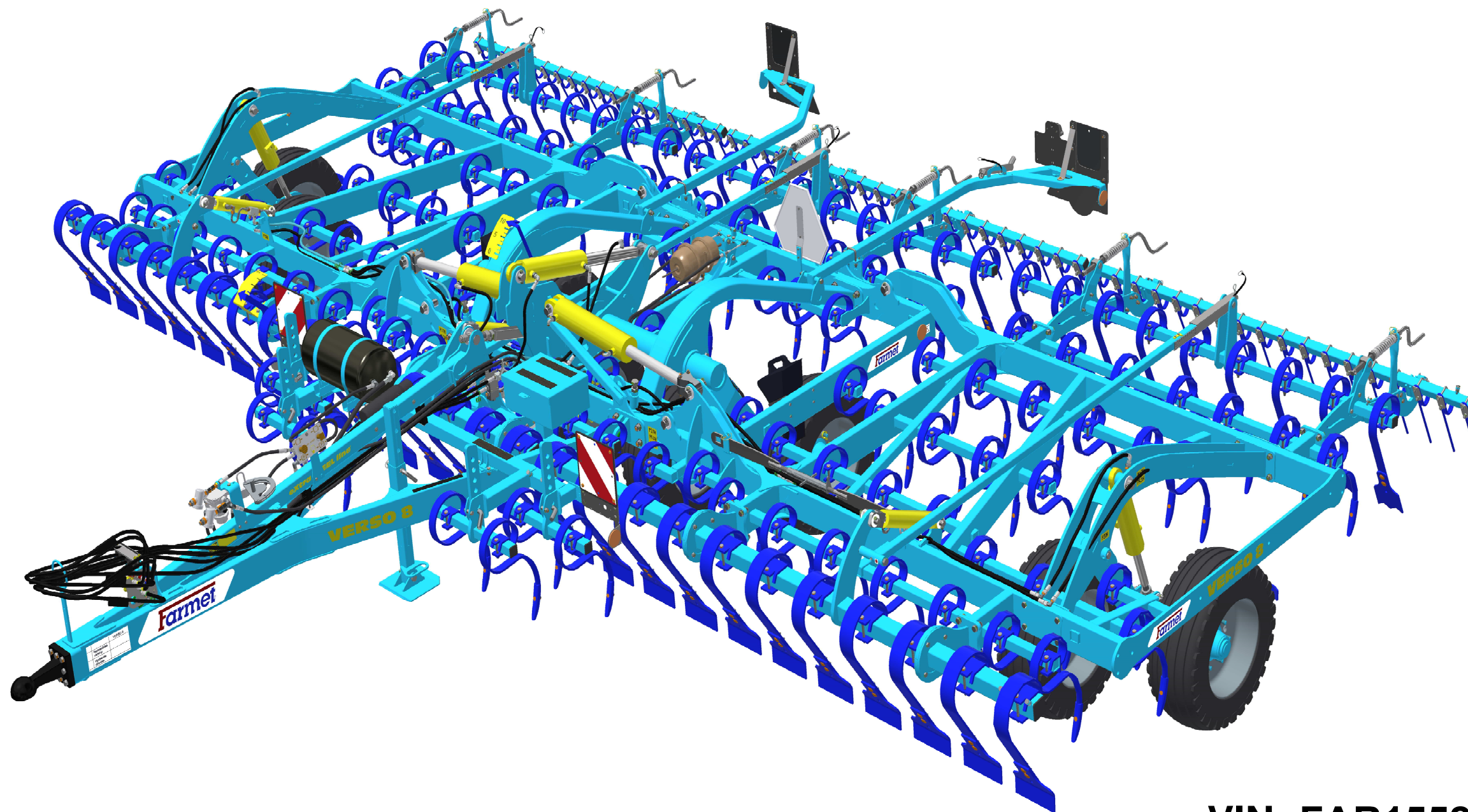

ⒸZ Platnost pro vrcholové | výrobní číslo stroje ⒸB Validity for the top | serial number of the machine
ⒸD Gültigkeit für die Haupt- | Herstellungsnummer der Maschine ⒸRU Действительно для главного | заводского номера машины
ⒸF Validité du numéro de référence | de série de la machine ⒸPL Obowiązuje dla numeru głównego | seryjnego maszyny

VIN: FAR15520CN0001177
9319116|2022/1177

Farmet a. s.
Jiřinková 276
552 03 Česká Skalice, CZ

telefon: +420 491 450 111
fax: +420 491 450 136
GSM: +420 774 715 738

IČ: 46504931
DIČ: CZ46504931

web: www.farmet.cz
e-mail: farmet@farmet.cz

ⒸZ NAVIGACE STROJE

Ⓓ NAVIGATION DER MASCHINE

Ⓕ NAVIGATION DE LA MACHINE

ⒸB NAVIGATION OF THE MACHINE

ⒸU НАВИГАЦИЯ МАШИНЫ

ⒸL NAWIGACJA MASZYNY

Farmet

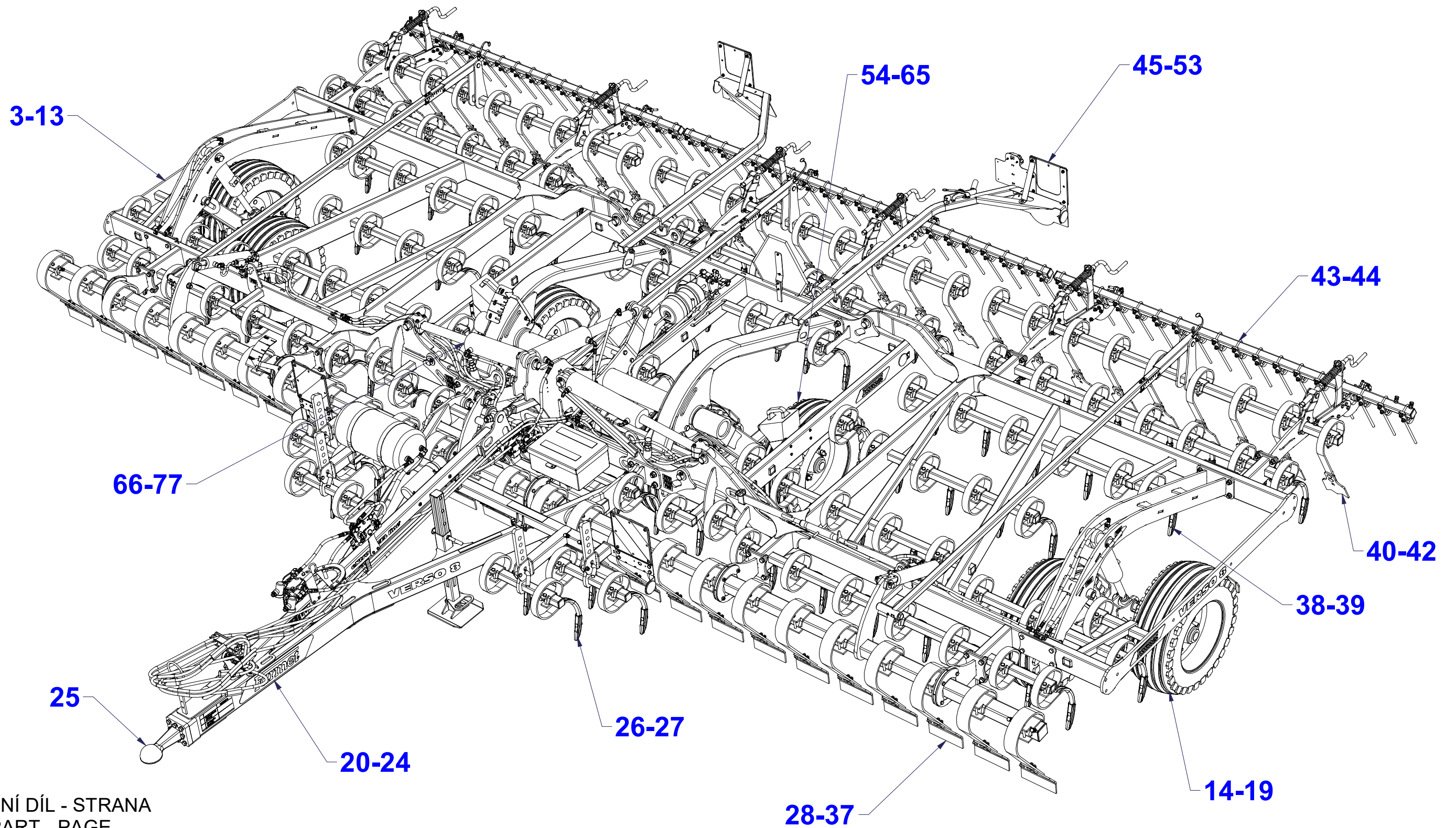

ⒸZ NÁHRADNÍ DÍL - STRANA

ⒸB SPARE PART - PAGE

Ⓓ ERSATZTEILE - SEITE

ⒸU ЗАПЧАСТЬ - СТРАНИЦА

Ⓕ PIÈCE DE RECHANGE - PAGE

ⒸL CZĘŚCI ZAMIENNE - STRONA

Ⓒ POLOTOVAR STROJE

Ⓓ MASCHINEN-HALBFABRIKAT

Ⓕ MACHINE - SEMI-PRODUIT

Ⓖ SEMIFINISHED MACHINE

Ⓡ ПОЛУФАБРИКАТ МАШИНЫ

Ⓢ PÓLFABRYKAT MASZYN



VZ00020225

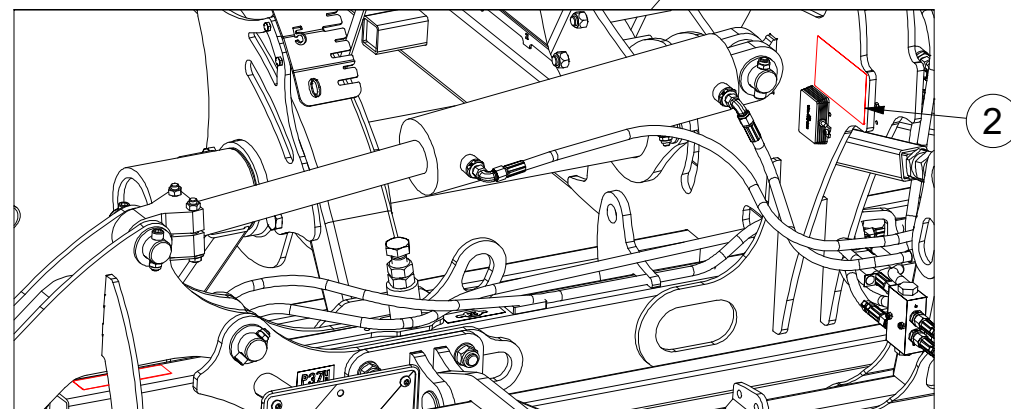
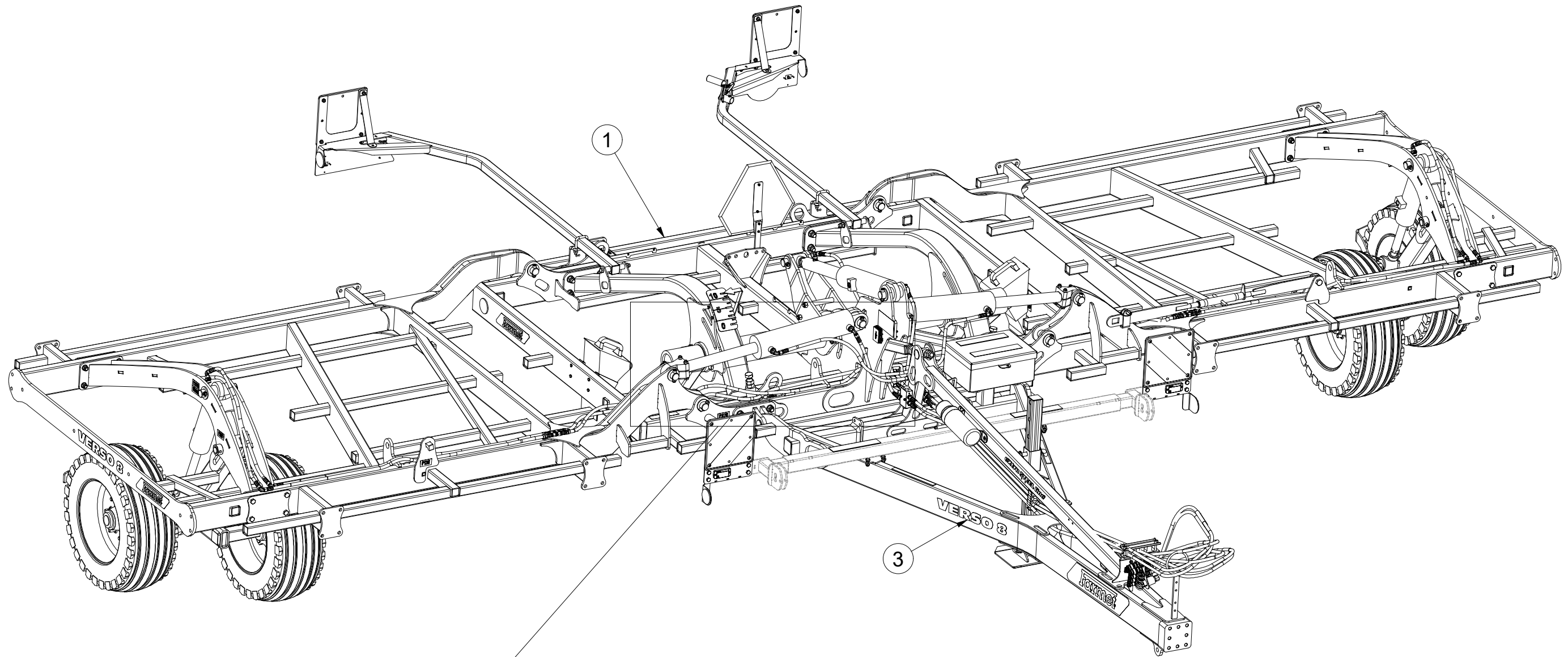

Pos.	Part Number	Pcs.
1	VZ00020223	1
2	4025948	1
3	m21231	1

☉ POLOTOVAR STROJE

☉ MASCHINEN-HALBFABRIKAT

☉ MACHINE - SEMI-PRODUIT

☉ SEMIFINISHED MACHINE

☉ ПОЛУФАБРИКАТ МАШИНЫ

☉ PÓLFABRYKAT MASZYNY



VZ00020223

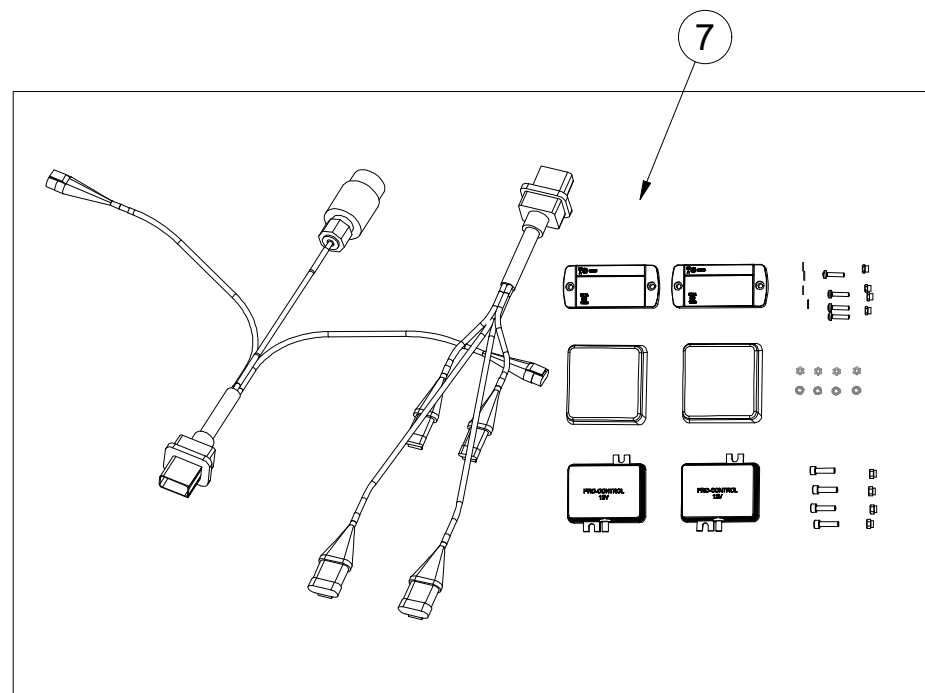
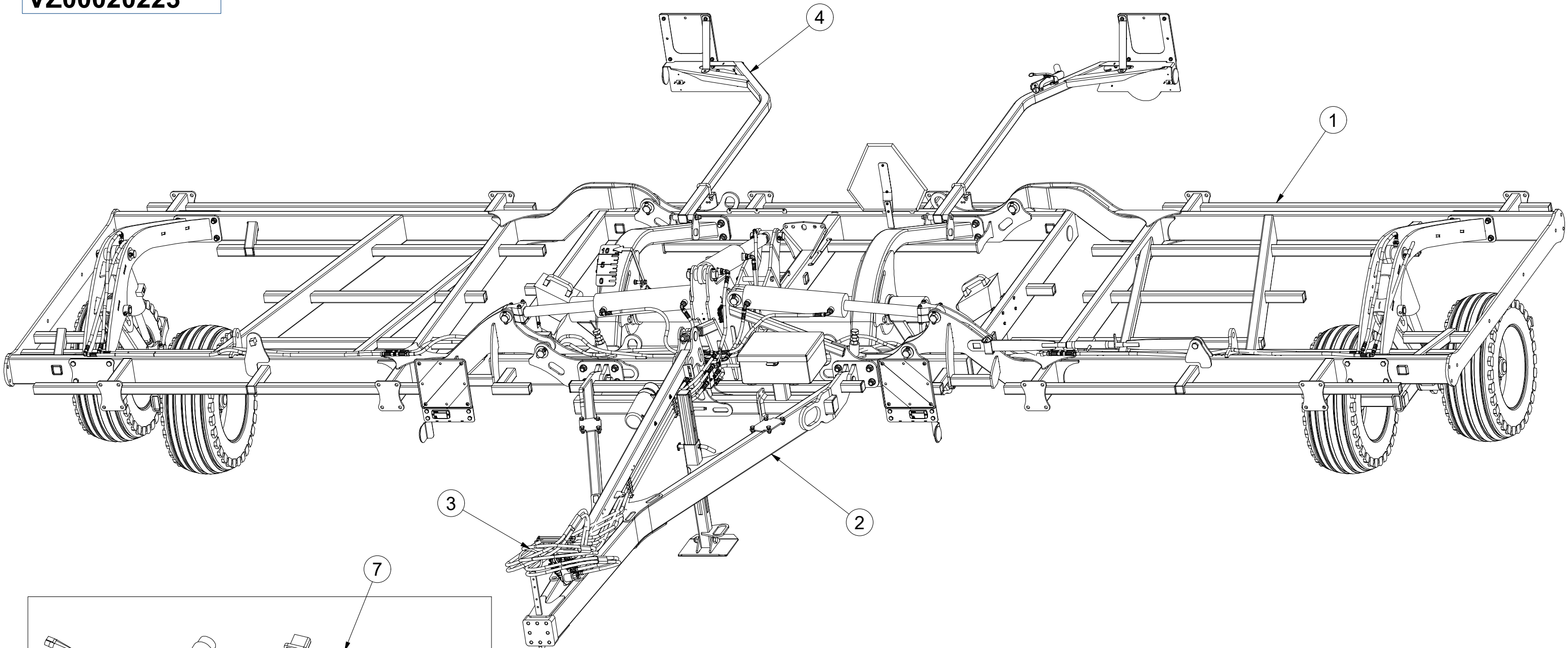

Pos.	Part Number	Pcs.
1	VZ00020224	1
2	VZ00005470	1
3	VZ00012055	1
4	VZ00012312	1
7	VZ00012659	1

Ⓒ POLOTOVAR STROJE

Ⓓ MASCHINEN-HALBFABRIKAT

Ⓕ MACHINE - SEMI-PRODUIT

Ⓖ SEMIFINISHED MACHINE

Ⓡ ПОЛУФАБРИКАТ МАШИНЫ

Ⓟ PÓŁFABRYKAT MASZYNY



VZ00020224

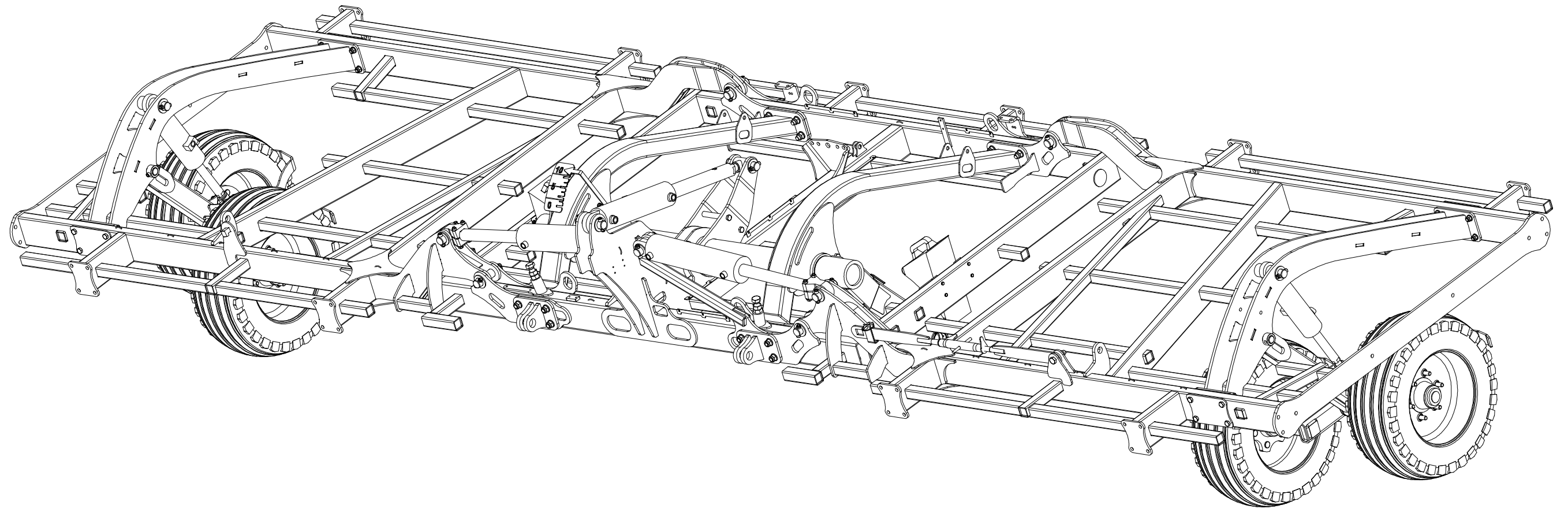

☉ POLOTOVAR STROJE

☉ MASCHINEN-HALBFABRIKAT

☉ MACHINE - SEMI-PRODUIT

☉ SEMIFINISHED MACHINE

☉ ПОЛУФАБРИКАТ МАШИНЫ

☉ PÓLFABRYKAT MASZYNY



VZ00020224

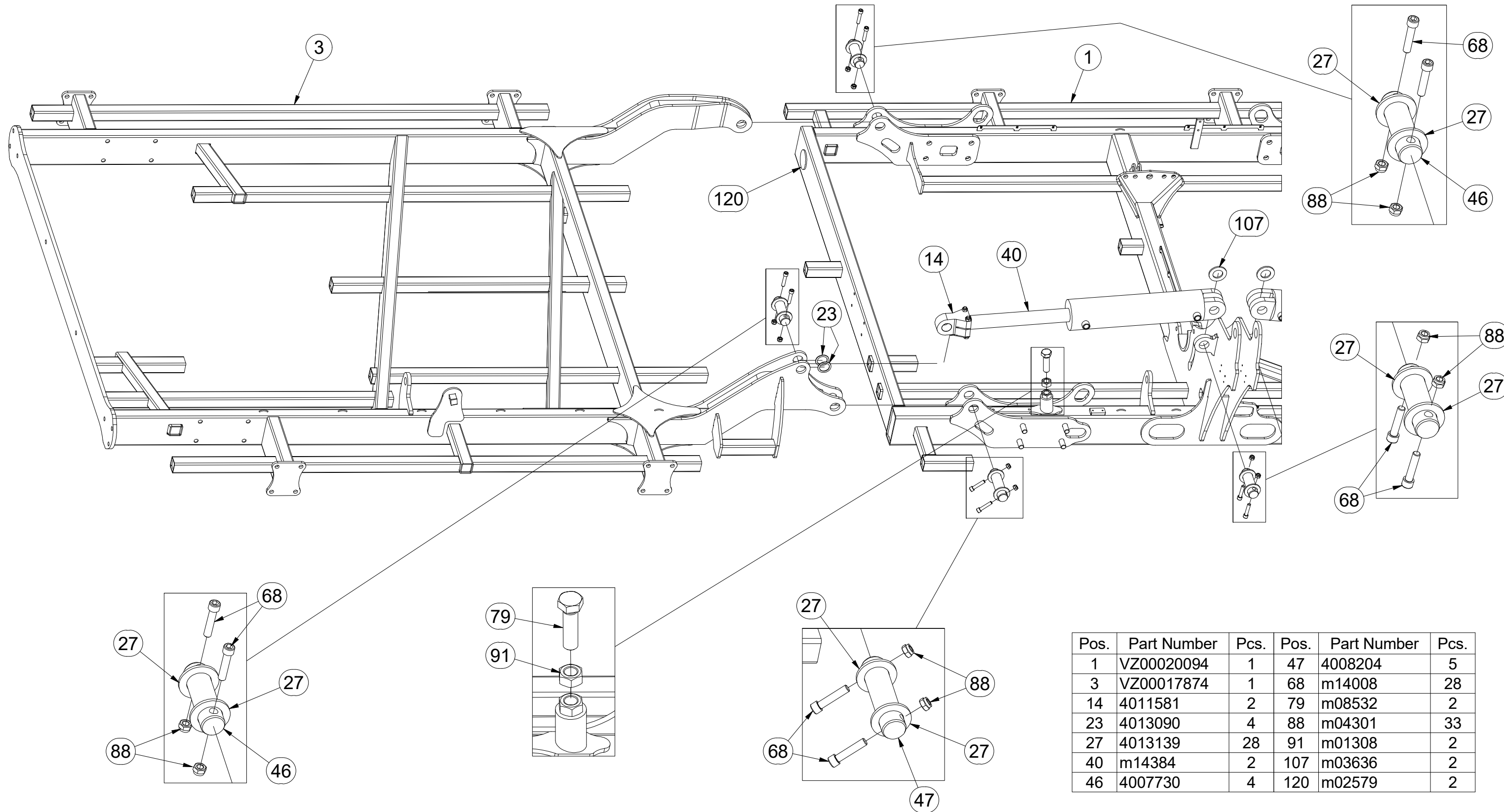

Pos.	Part Number	Pcs.	Pos.	Part Number	Pcs.
1	VZ00020094	1	47	4008204	5
3	VZ00017874	1	68	m14008	28
14	4011581	2	79	m08532	2
23	4013090	4	88	m04301	33
27	4013139	28	91	m01308	2
40	m14384	2	107	m03636	2
46	4007730	4	120	m02579	2

☉ POLOTOVAR STROJE

☉ MASCHINEN-HALBFABRIKAT

☉ MACHINE - SEMI-PRODUIT

☉ SEMIFINISHED MACHINE

☉ ПОЛУФАБРИКАТ МАШИНЫ

☉ PÓLFABRYKAT MASZYNY



VZ00020224

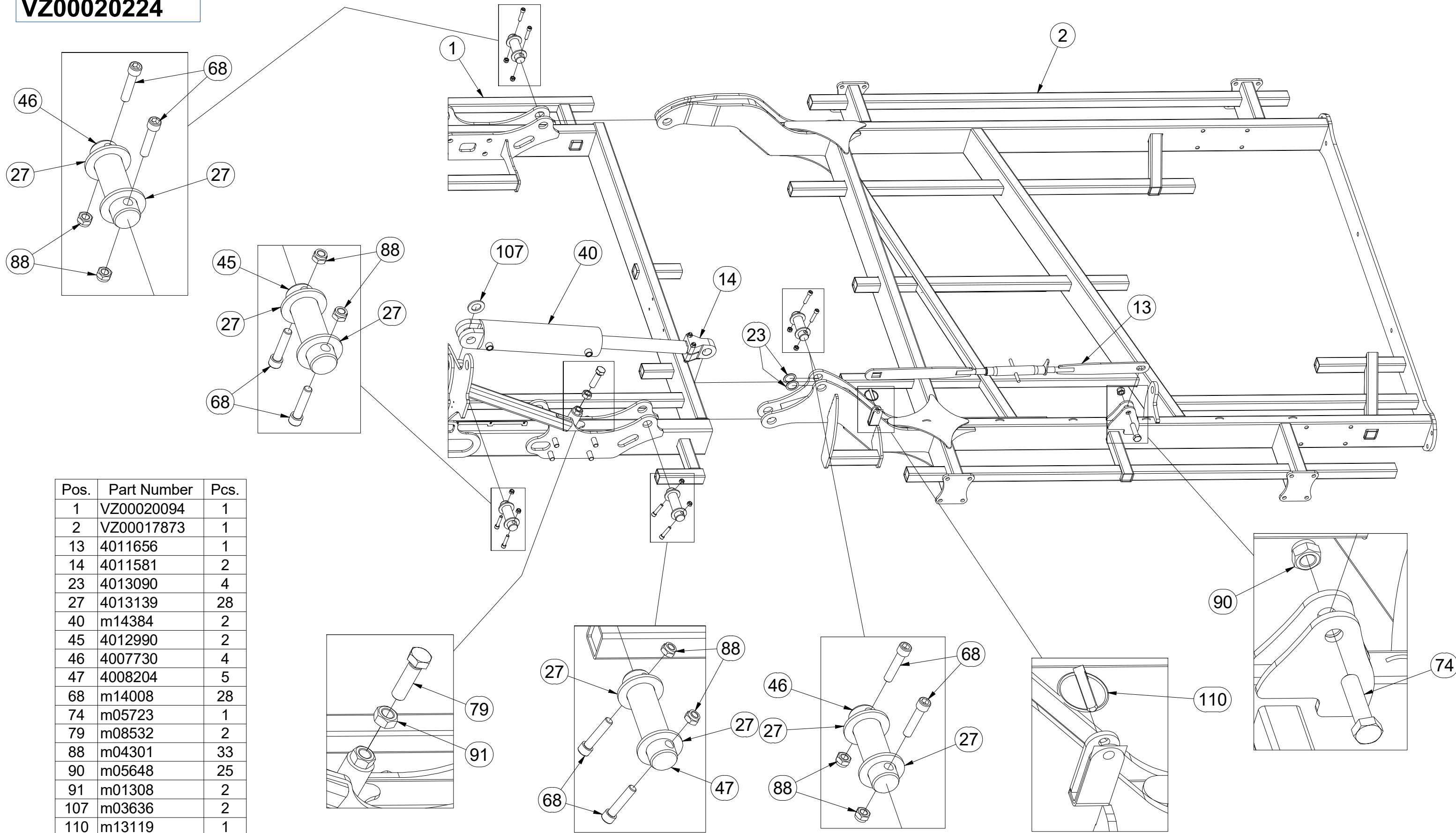

Pos.	Part Number	Pcs.
1	VZ00020094	1
2	VZ00017873	1
13	4011656	1
14	4011581	2
23	4013090	4
27	4013139	28
40	m14384	2
45	4012990	2
46	4007730	4
47	4008204	5
68	m14008	28
74	m05723	1
79	m08532	2
88	m04301	33
90	m05648	25
91	m01308	2
107	m03636	2
110	m13119	1

☉ POLOTOVAR STROJE

☐ MASCHINEN-HALBFABRIKAT

☐ MACHINE - SEMI-PRODUIT

☉ SEMIFINISHED MACHINE

☐ ПОЛУФАБРИКАТ МАШИНЫ

☐ PÓŁFABRYKAT MASZYNY



VZ00020224

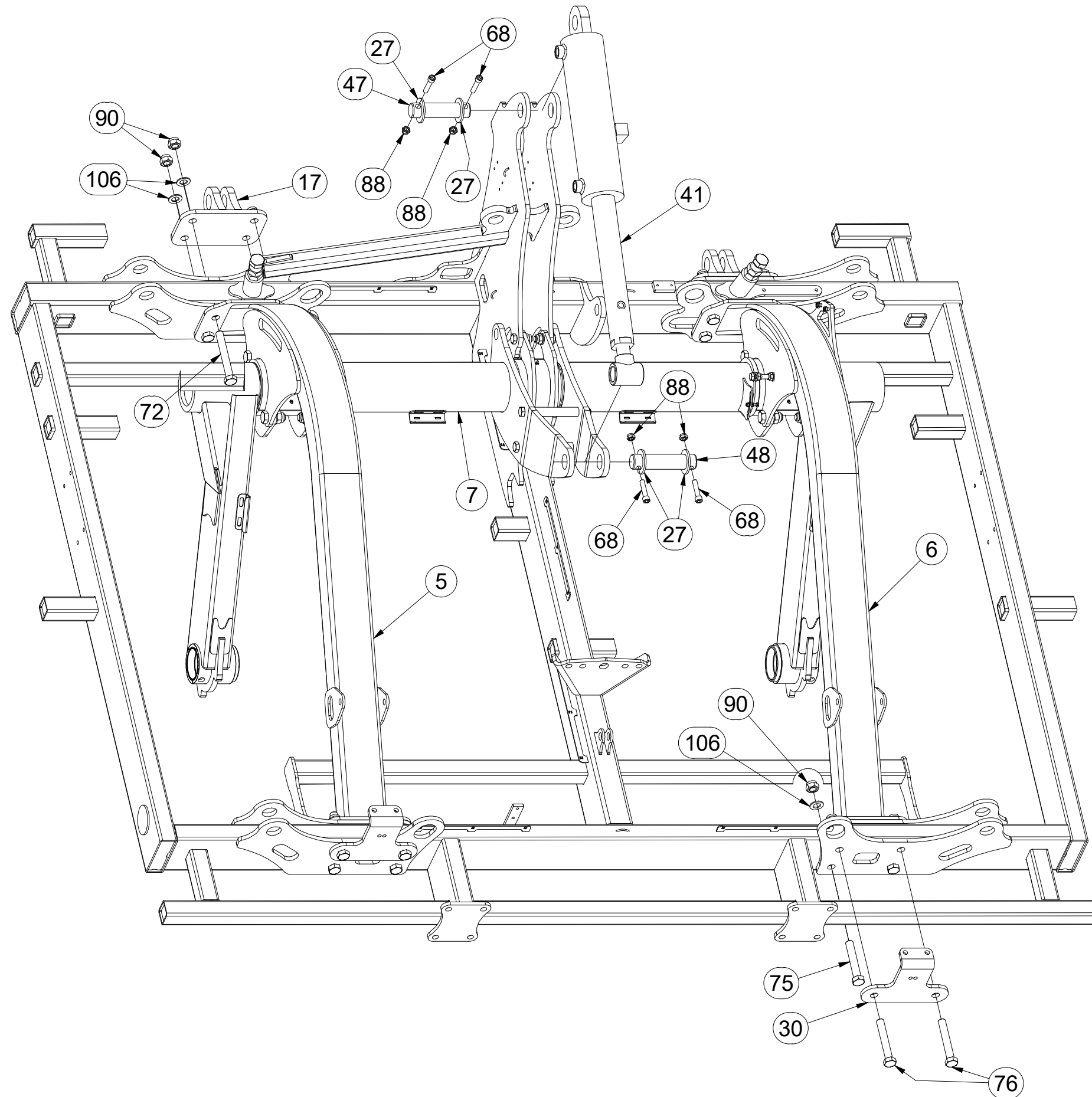

Pos.	Part Number	Pcs.
5	3006542	1
6	3006543	1
7	2000630	1
17	VZ00020848	2
27	4013139	28
30	4013073	2
41	m13432	1
47	4008204	5
48	4011501	1
68	m14008	28
72	m13361	8
75	m09448	4
76	m05465	4
88	m04301	33
90	m05648	25
106	m03768	25

Ⓒ POLOTOVAR STROJE

Ⓓ MASCHINEN-HALBFABRIKAT

Ⓕ MACHINE - SEMI-PRODUIT

Ⓖ SEMIFINISHED MACHINE

Ⓡ ПОЛУФАБРИКАТ МАШИНЫ

Ⓢ РОЉФАБРИКАТ МАСЗЫНЫ



VZ00020224

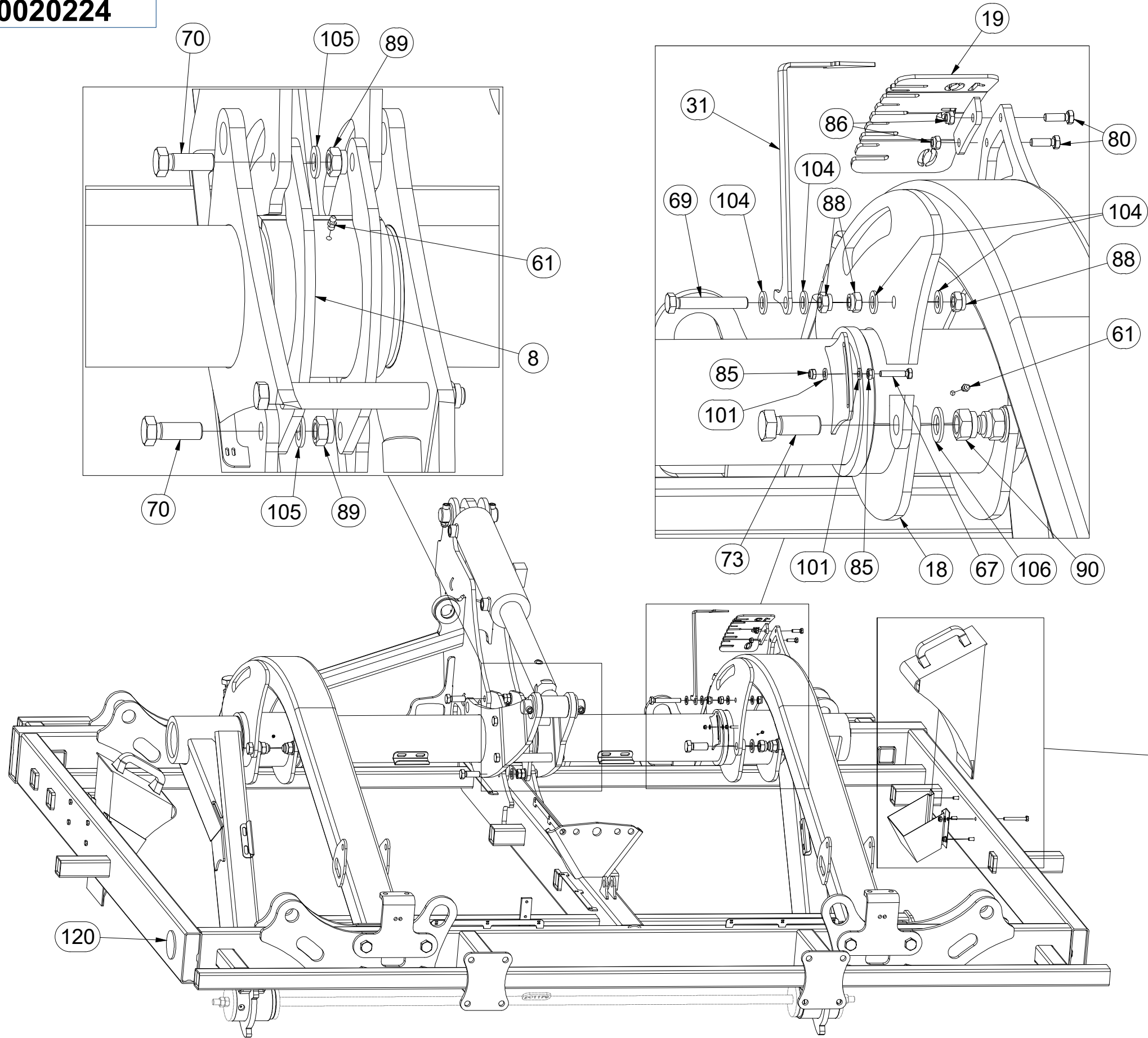

Pos.	Part Number	Pcs.	Pos.	Part Number	Pcs.
8	3005891	1	86	m04503	10
18	3005875	2	88	m04301	33
19	4016288	1	89	m03683	20
31	4011635	1	90	m05648	25
61	m01725	3	101	m01199	2
67	m01077	1	102	m01203	8
69	m06446	1	104	m01214	4
70	m02254	4	105	m01219	20
73	m08378	8	106	m03768	25
78	m03931	8	116	m12572	2
80	m01092	2	117	m16186	2
85	m05560	2	120	m02579	2

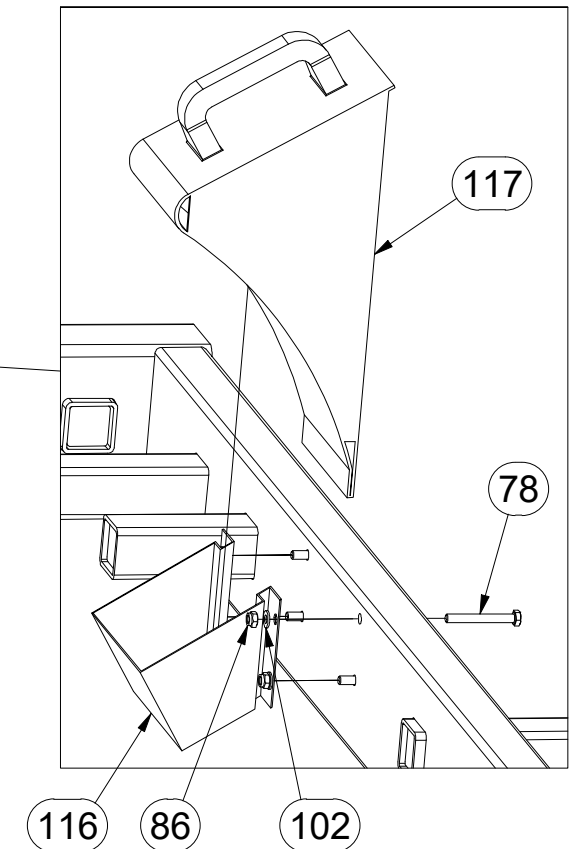

Ⓒ POLOTOVAR STROJE

Ⓓ MASCHINEN-HALBFABRIKAT

Ⓕ MACHINE - SEMI-PRODUIT

Ⓖ SEMIFINISHED MACHINE

Ⓡ ПОЛУФАБРИКАТ МАШИНЫ

Ⓢ PÓLFABRYKAT MASZYNY



VZ00020224

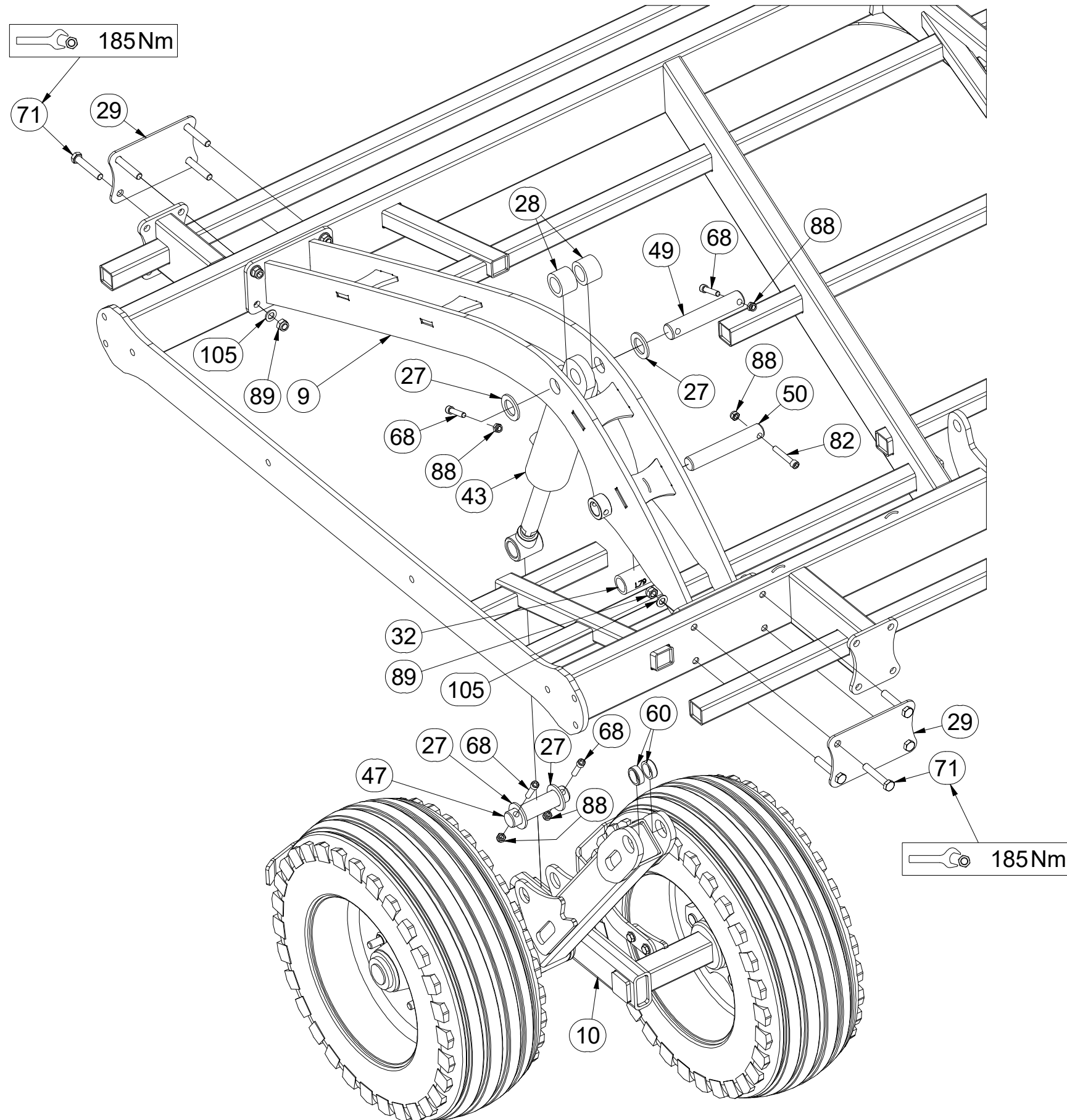

Pos.	Part Number	Pcs.
9	3008572	1
10	VZ00022455	1
27	4013139	28
28	4011691	4
29	4011701	4
32	VZ00003839	2
43	m13433	1
47	4008204	5
49	4007642	2
50	4016833	2
60	m14979	4
68	m14008	28
71	m03215	16
82	m13033	2
88	m04301	33
89	m03683	20
105	m01219	20

☉ POLOTOVAR STROJE

☉ MASCHINEN-HALBFABRIKAT

☉ MACHINE - SEMI-PRODUIT

☉ SEMIFINISHED MACHINE

☉ ПОЛУФАБРИКАТ МАШИНЫ

☉ PÓŁFABRYKAT MASZYNY



VZ00020224

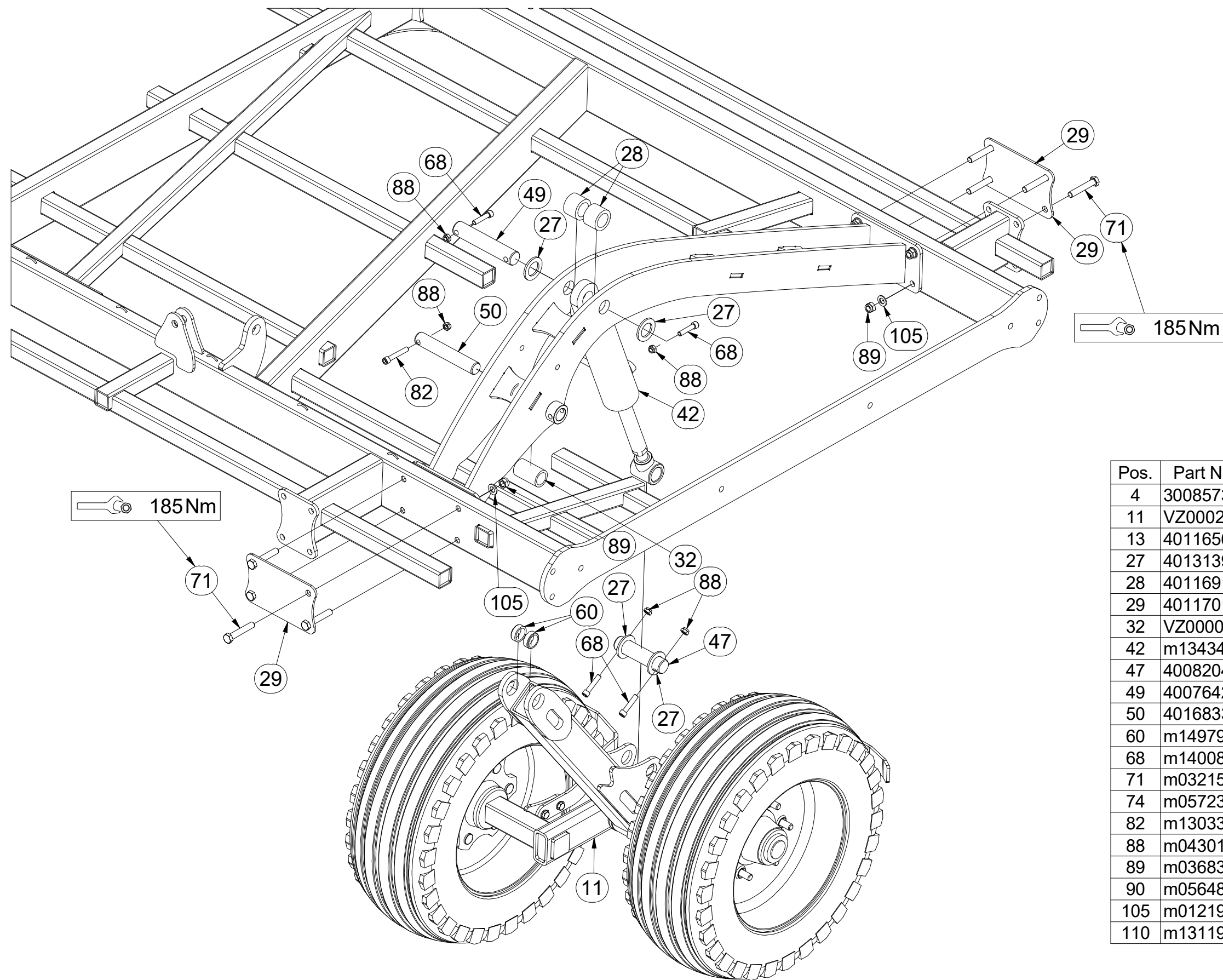

Pos.	Part Number	Pcs.
4	3008573	1
11	VZ00022457	1
13	4011656	1
27	4013139	28
28	4011691	4
29	4011701	4
32	VZ00003839	2
42	m13434	1
47	4008204	5
49	4007642	2
50	4016833	2
60	m14979	4
68	m14008	28
71	m03215	16
74	m05723	1
82	m13033	2
88	m04301	33
89	m03683	20
90	m05648	25
105	m01219	20
110	m13119	1

Ⓒ OKO PÍSTNICE

Ⓓ BEFESTIGUNGSBUCHSE-SATZ

Ⓕ ŒILLET DE LA TÊTE DE PISTON

4011581

Ⓖ PISTON ROD LUG

Ⓡ ПРОУШИНА ЦИЛИНДРА

Ⓟ UCHO TŁOKU

Farmet

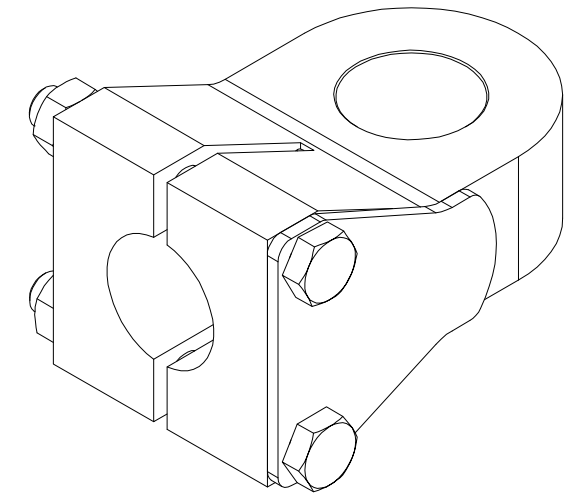
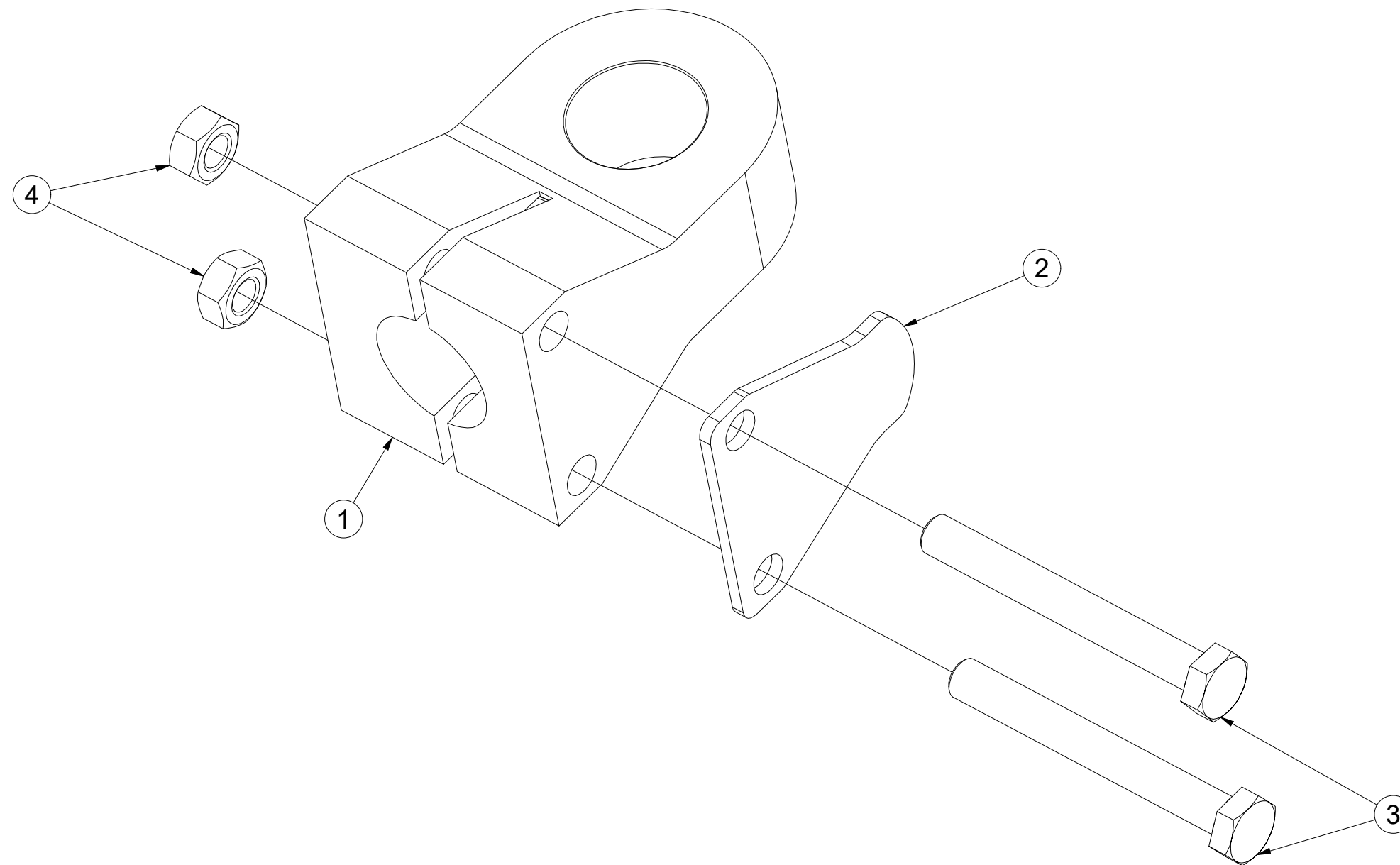

Pos.	Part Number	Pcs.
1	m21048	1
2	4011703	1
3	m11598	2
4	m10439	2

☉ SPOJOVACÍ TÁHLO

☉ VERBINDUNGSSTANGE

☉ TIGE DE RACCORDEMENT

☉ CONNECTING ROD

☉ СОЕДИНИТЕЛЬНАЯ ТЯГА

☉ KORBOWÓD



4011656

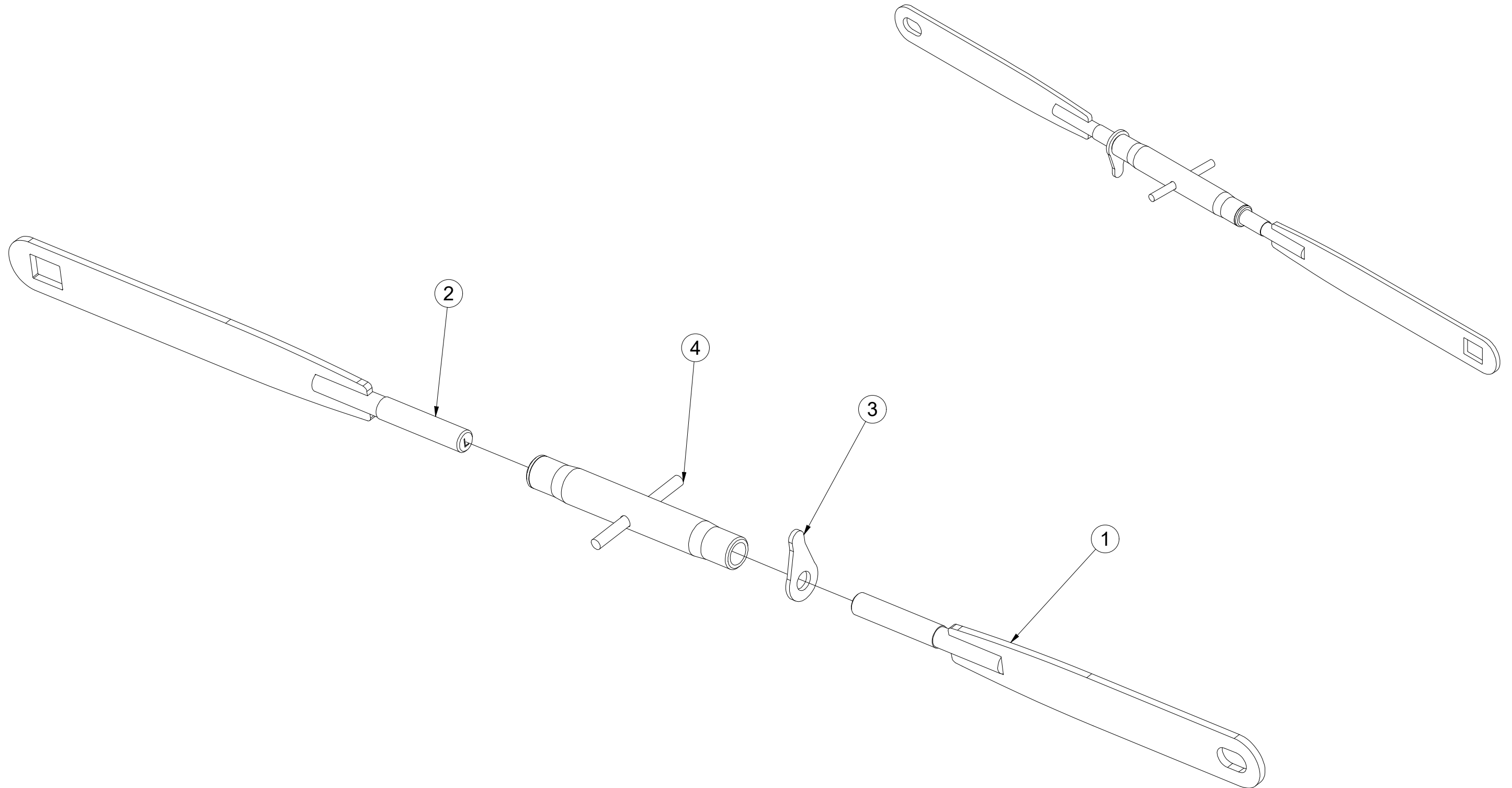

Pos.	Part Number	Pcs.
1	4011655	1
2	4011653	1
3	m08881	1
4	m08880	1

☉ TANDEMŮVÉ KOLO - LEVÉ

☉ TANDEMRAD - LINKES

☉ ROUE TANDEM - GAUCHE

☉ TANDEM WHEEL - LEFT

☉ ТАНДЕМНОЕ КОЛЕСО - ПЕВОЕ

☉ KOŁO TANDEMOWE - LEWE



VZ00022455

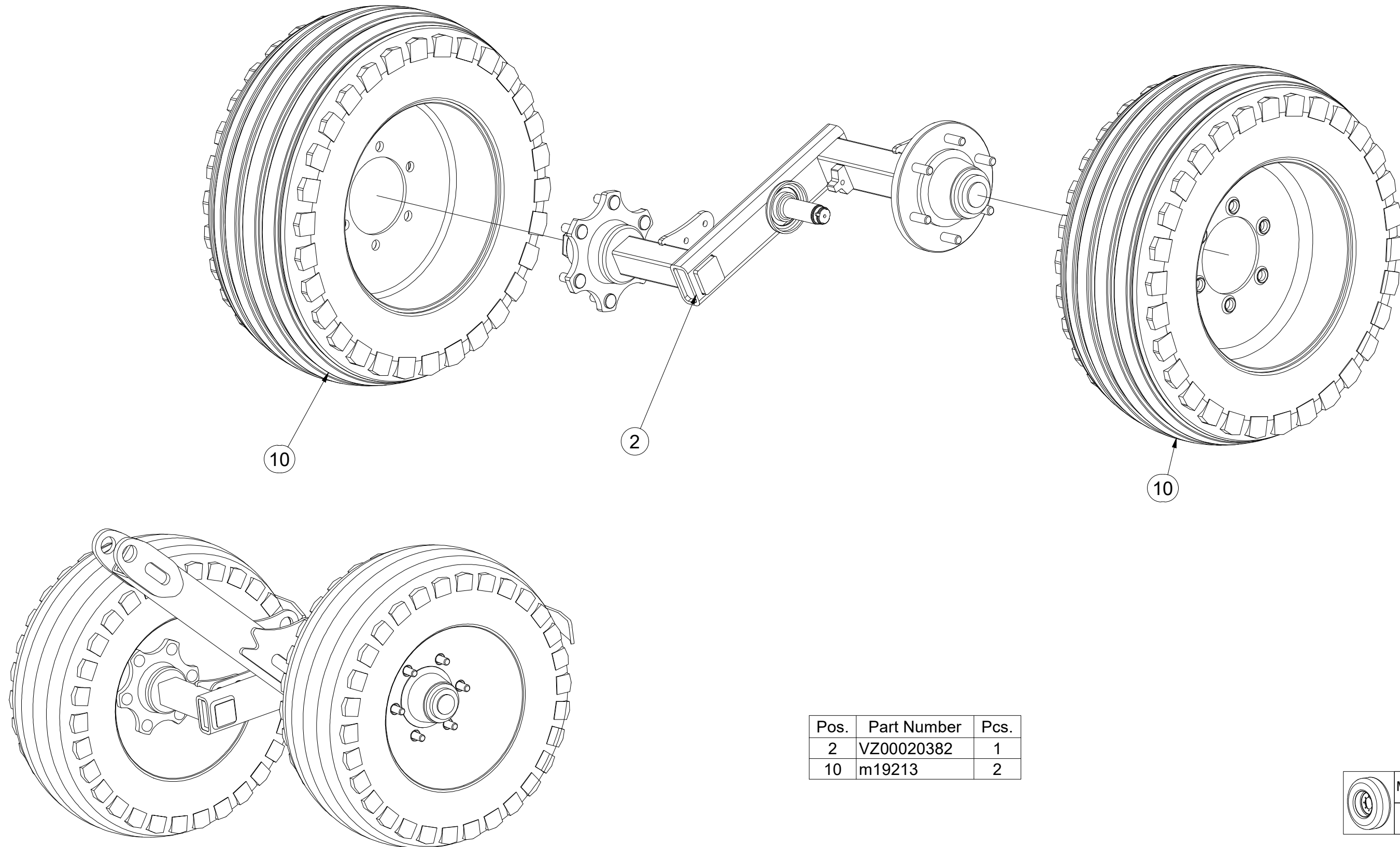

Pos.	Part Number	Pcs.
2	VZ00020382	1
10	m19213	2

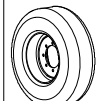
	M18x1,5-265Nm
	350 kPa

ⒸZ TANDEMŮVÉ KOLO - LEVÉ

Ⓓ TANDEM RAD - LINKES

Ⓕ ROUE TANDEM - GAUCHE

ⒸB TANDEM WHEEL - LEFT

ⒸU ТАНДЕМНОЕ КОЛЕСО - ПЕВОЕ

ⒸL KOŁO TANDEMOWE - LEWE



VZ00022455

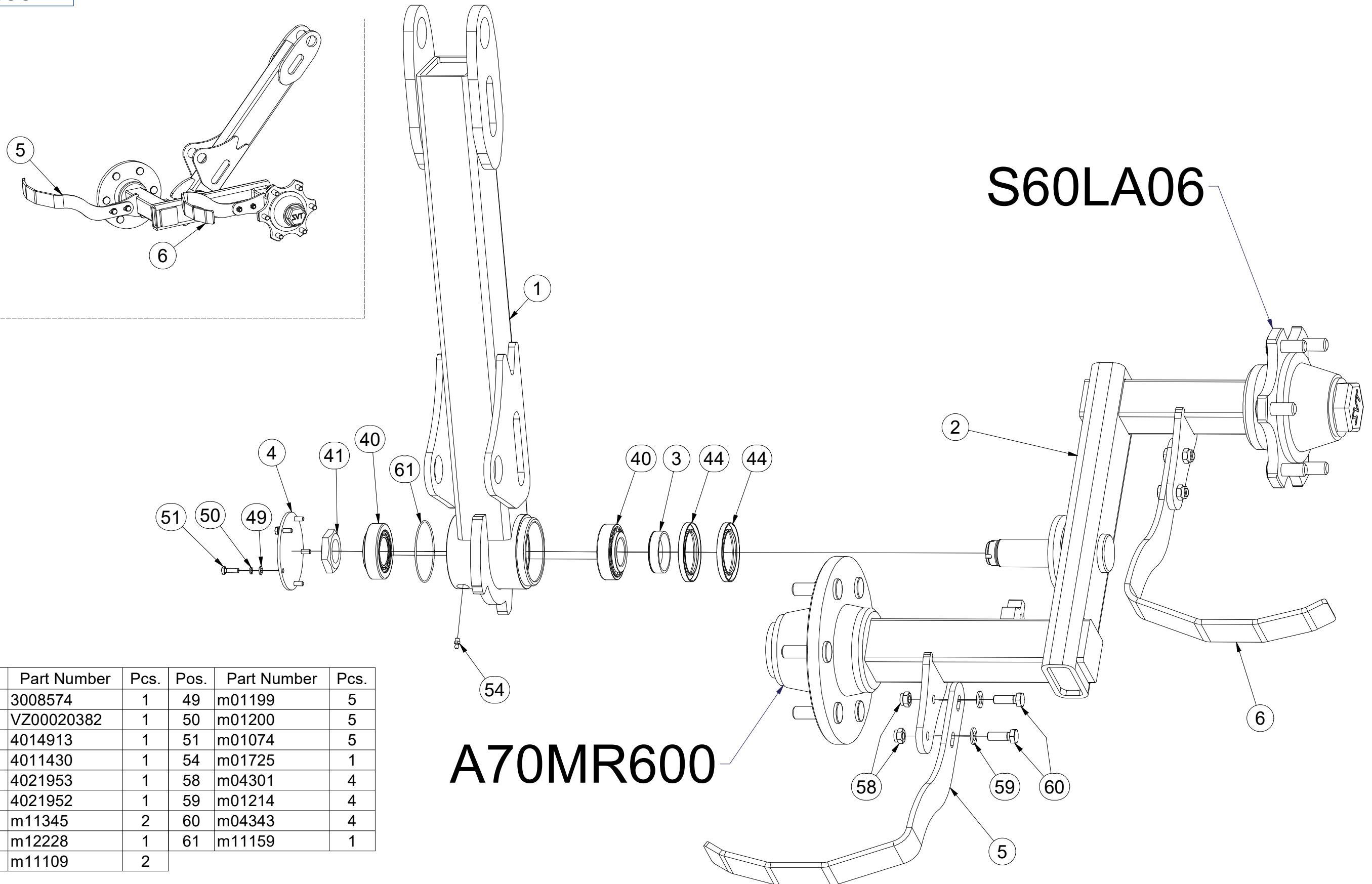

Pos.	Part Number	Pcs.	Pos.	Part Number	Pcs.
1	3008574	1	49	m01199	5
2	VZ00020382	1	50	m01200	5
3	4014913	1	51	m01074	5
4	4011430	1	54	m01725	1
5	4021953	1	58	m04301	4
6	4021952	1	59	m01214	4
40	m11345	2	60	m04343	4
41	m12228	1	61	m11159	1
44	m11109	2			

A70MR600

S60LA06

☉ TANDEMŮVÉ KOLO - PRAVÉ

☉ TANDEM RAD - RECHTES

☉ ROUE TANDEM - DROITE

VZ00022457

☉ TANDEM WHEEL - RIGHT

☉ ТАНДЕМНОЕ КОЛЕСО - ПРАВОЕ

☉ KOŁO TANDEMOWE - PRAWO

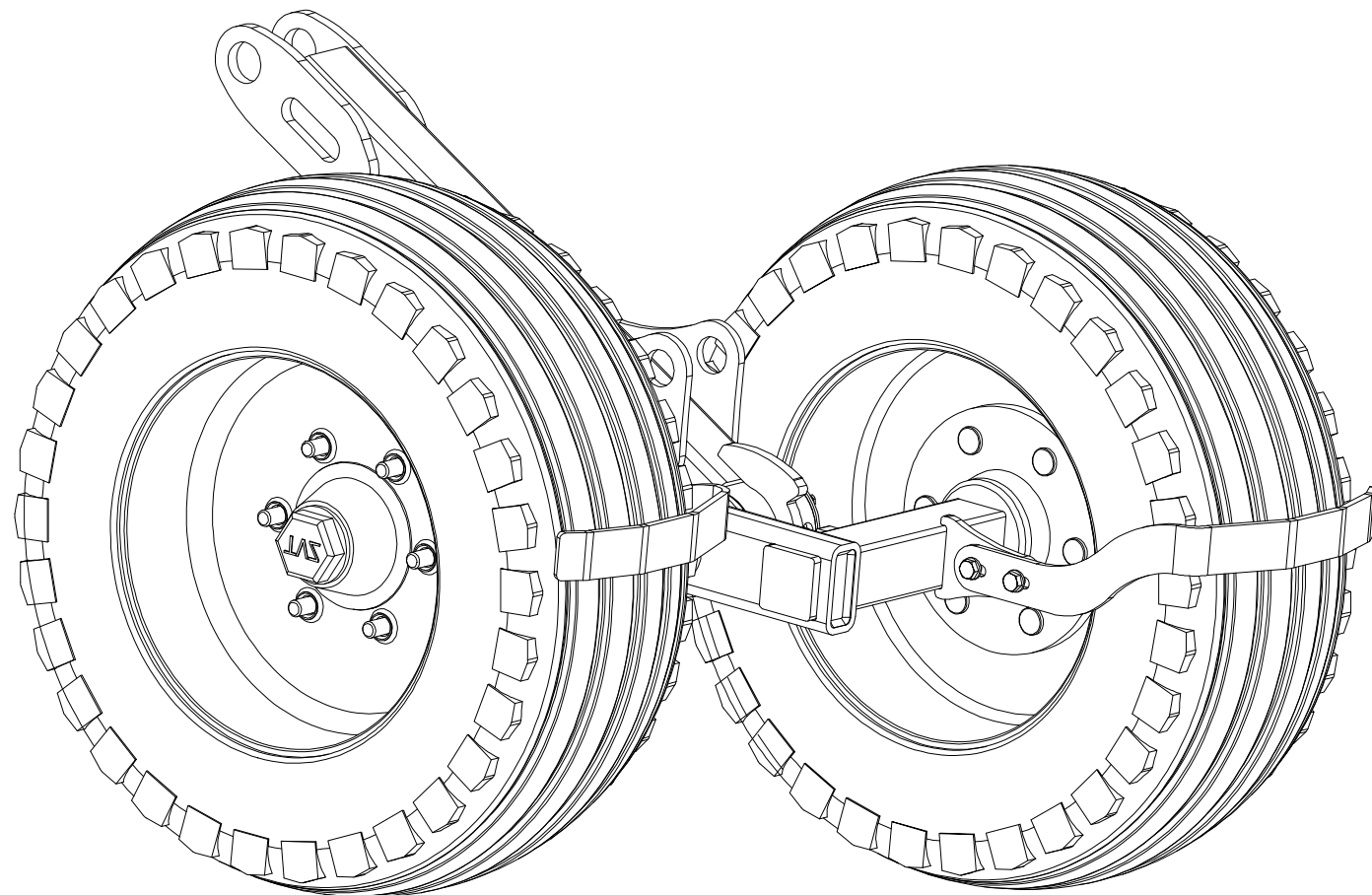
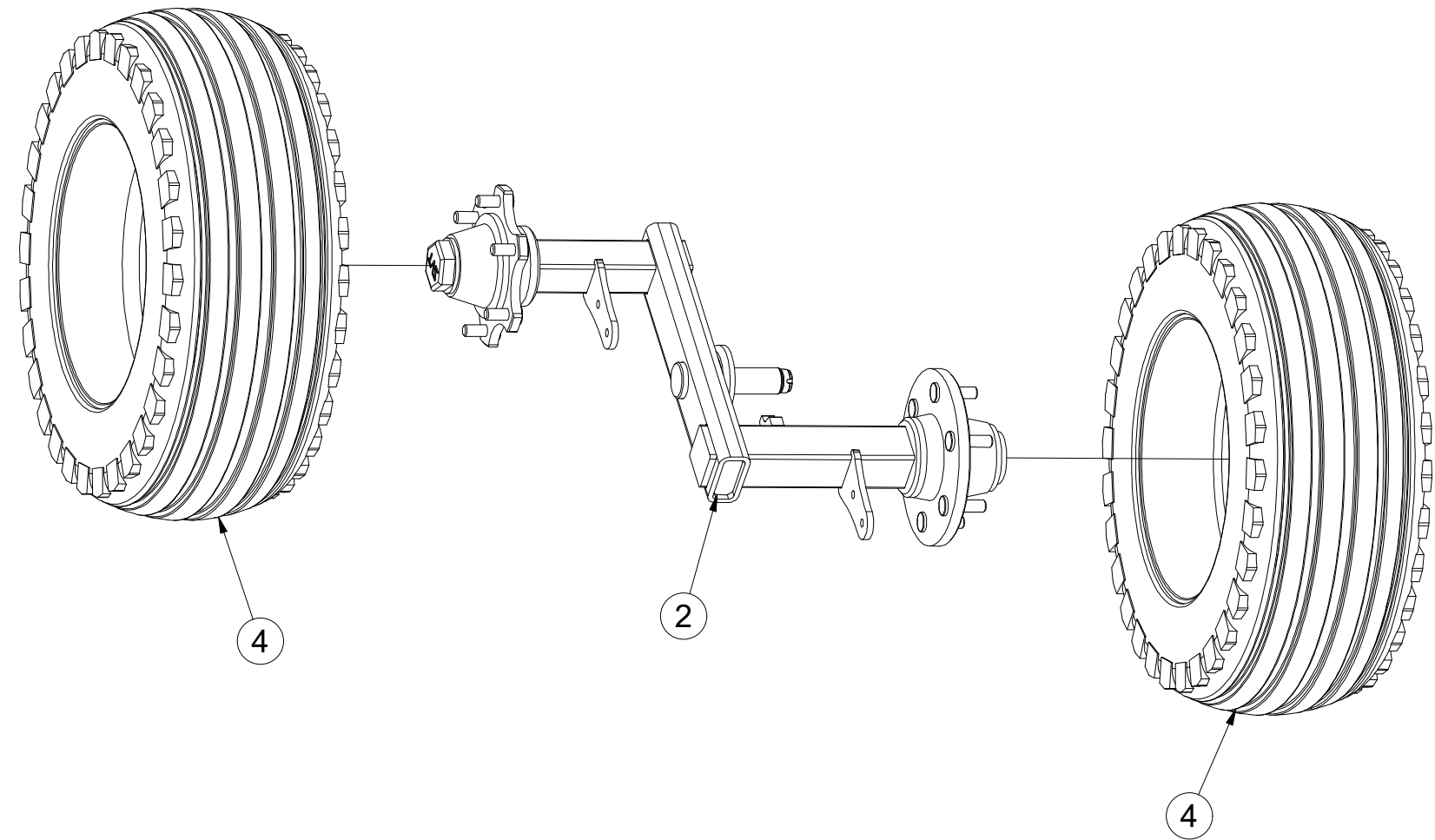

Pos.	Part Number	Pcs.
2	VZ00020382	1
4	m19213	2

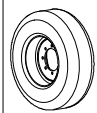
	M18x1,5-265Nm
	350 kPa

ⒸZ TANDEMŮVÉ KOLO - PRAVÉ

Ⓓ TANDEMRAD - RECHTES

Ⓕ ROUE TANDEM - DROITE

ⒸB TANDEM WHEEL - RIGHT

ⒸU ТАНДЕМНОЕ КОЛЕСО - ПРАВОЕ

ⒸL KOŁO TANDEMOWE - PRAWO



VZ00022457

Pos.	Part Number	Pcs.	Pos.	Part Number	Pcs.
1	3008575	1	44	m11109	2
2	VZ00020382	1	49	m01199	5
3	4014913	1	50	m01200	5
4	m19213	2	51	m01074	5
5	4011430	1	54	m01725	1
6	4021953	1	58	m04301	4
7	4021952	1	59	m01214	4
40	m11345	2	60	m04343	4
41	m12228	1	61	m11159	1

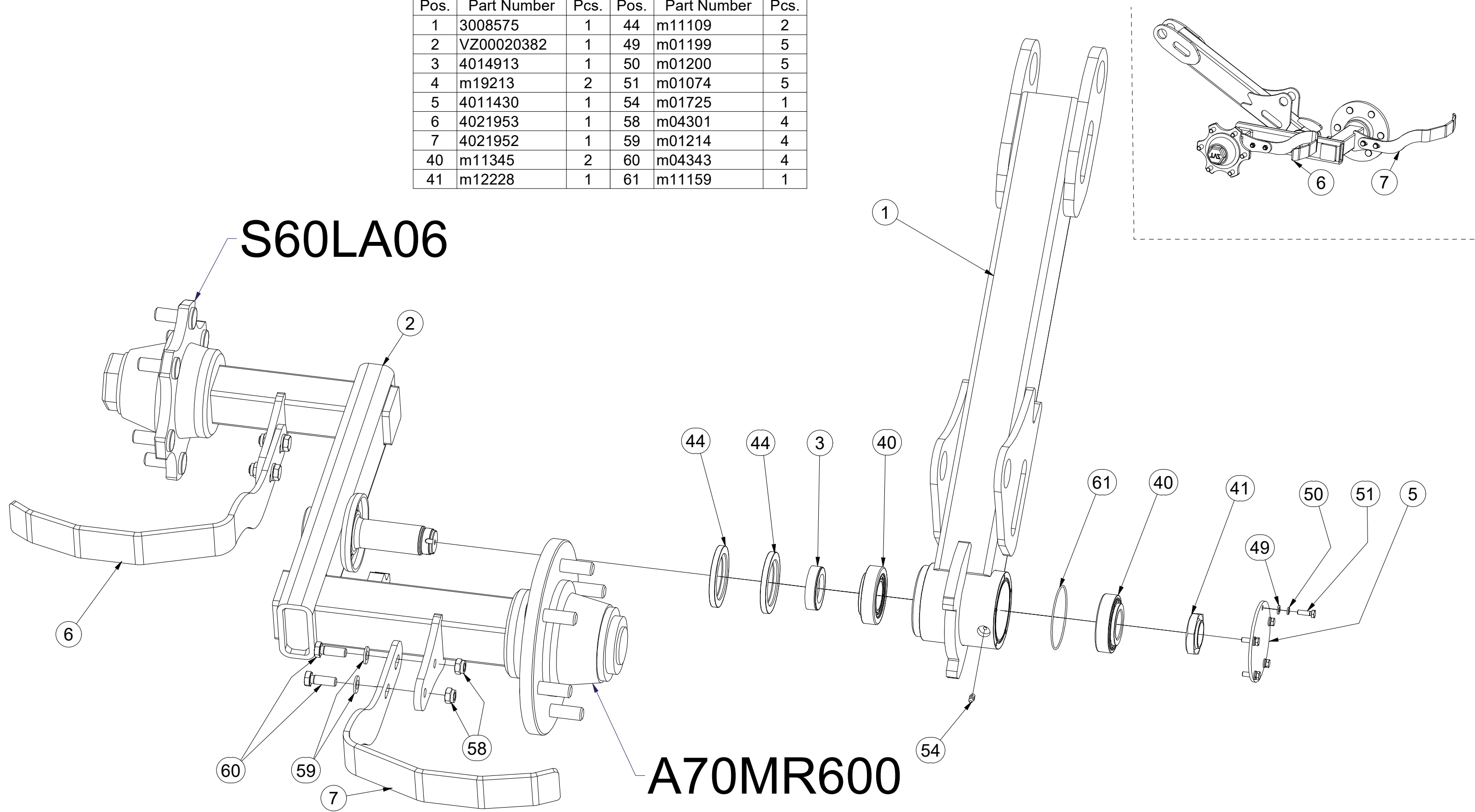

ⒸZ NÁPRAVA

ⒹACHSE

ⒻESSIEU

ⒼB AXLE

ⒺU OCB

ⒽL OS



A70MR06

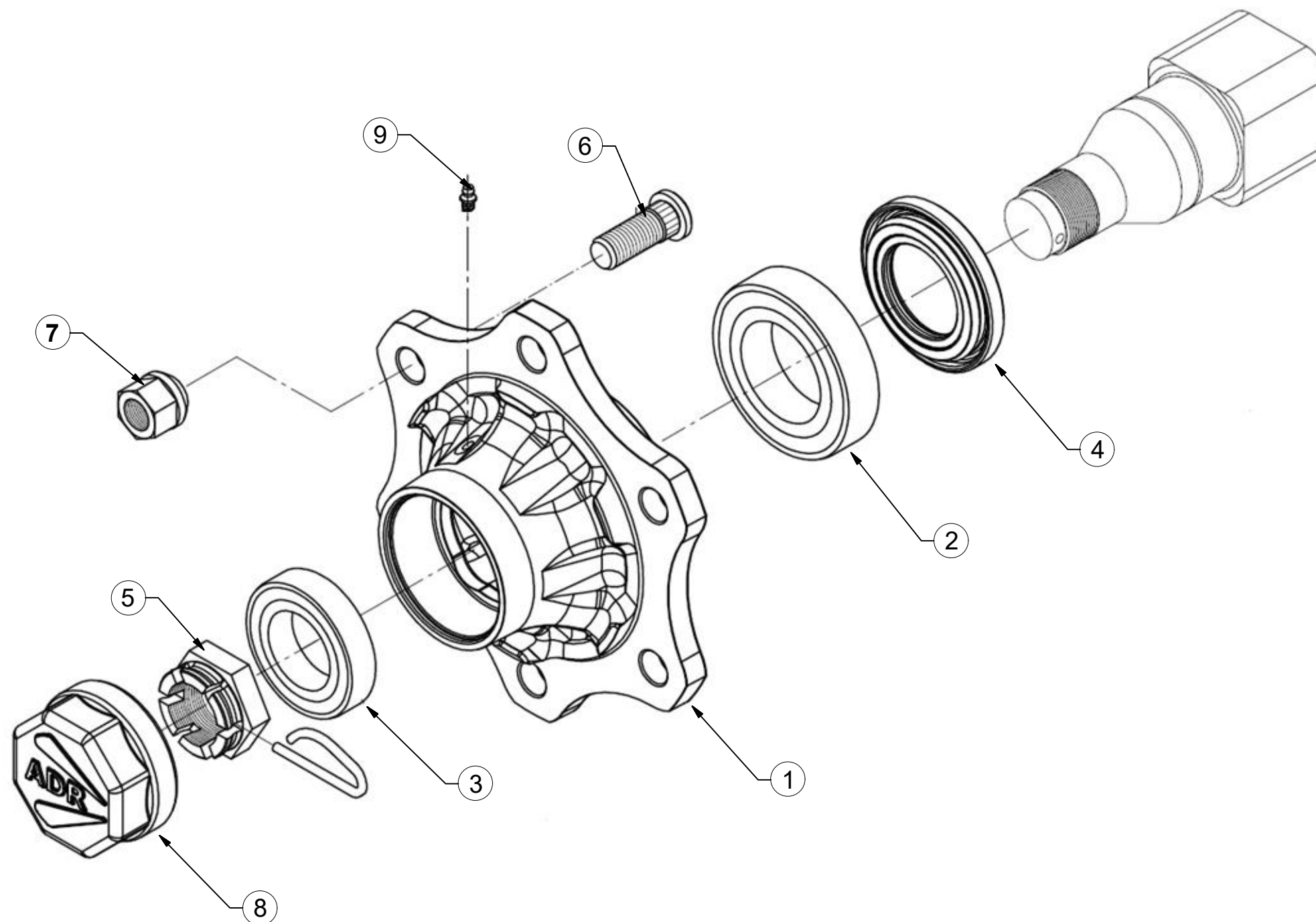

Pos	Part Number	Pcs.
1	m19667	2
2	m08194	2
3	m07152	2
4	m14924	2
5	m08169	2
6	m08148	12
7	m08163	12
8	m19668	2
9	m05698	2

Ⓒ NÁPRAVA

Ⓓ ACHSE

Ⓕ ESSIEU

Ⓒ AXLE

Ⓓ OCB

Ⓕ OS



S60LA06

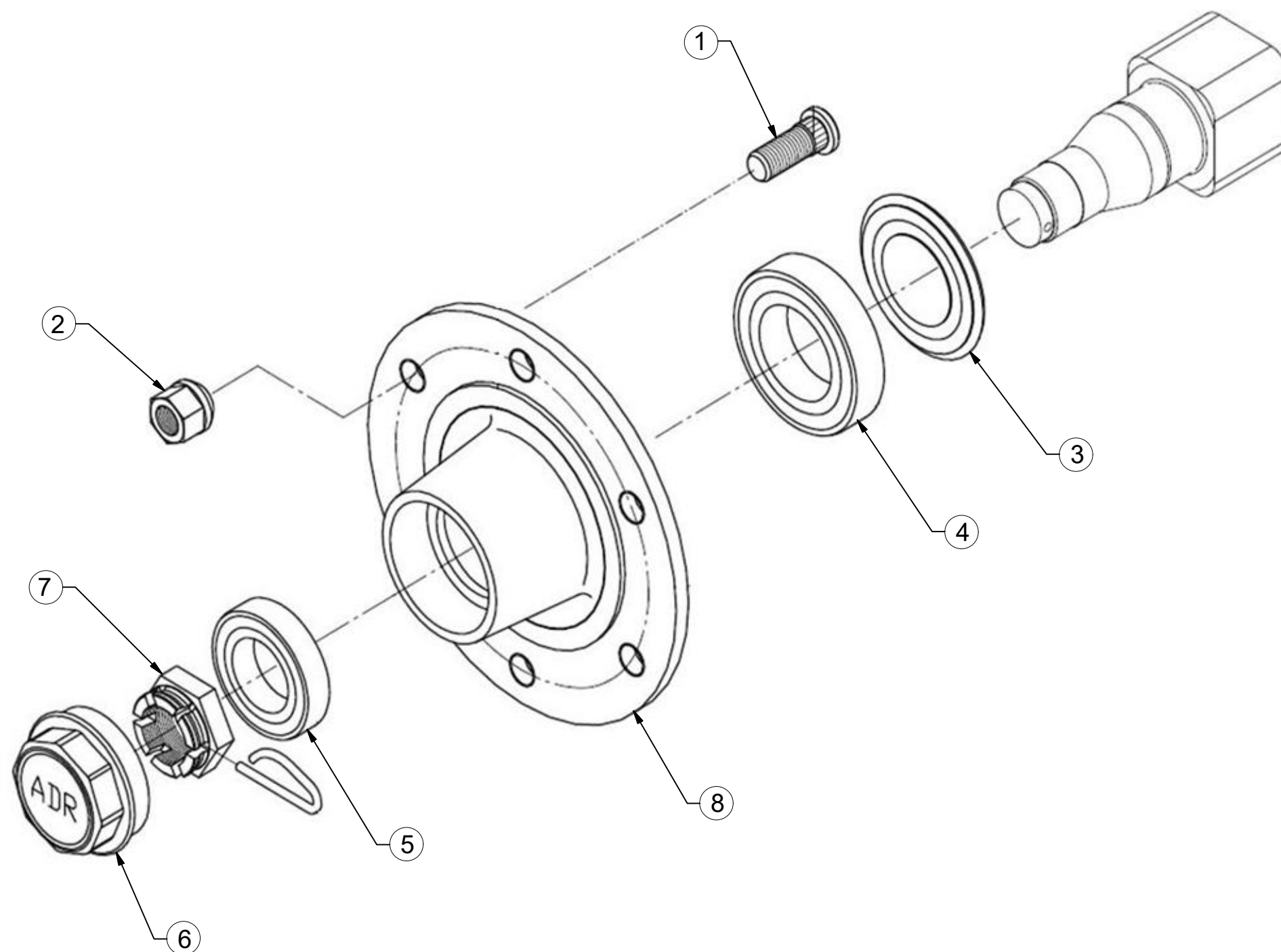

Pos.	Part Number	Pcs.
1	m08148	6
2	m08163	6
3	m08153	1
4	m07151	1
5	m07152	1
6	m08162	1
7	m08169	1
8	m08177	1

Ⓒ OJ MONT

Ⓓ DEICHSEL MONTIERT

Ⓕ TIMON MONTÉ

VZ00005470

Ⓖ MONT DRAWBAR

Ⓡ ДЫШЛО МОНТ.

Ⓟ DYSZEL MONT

Farmet

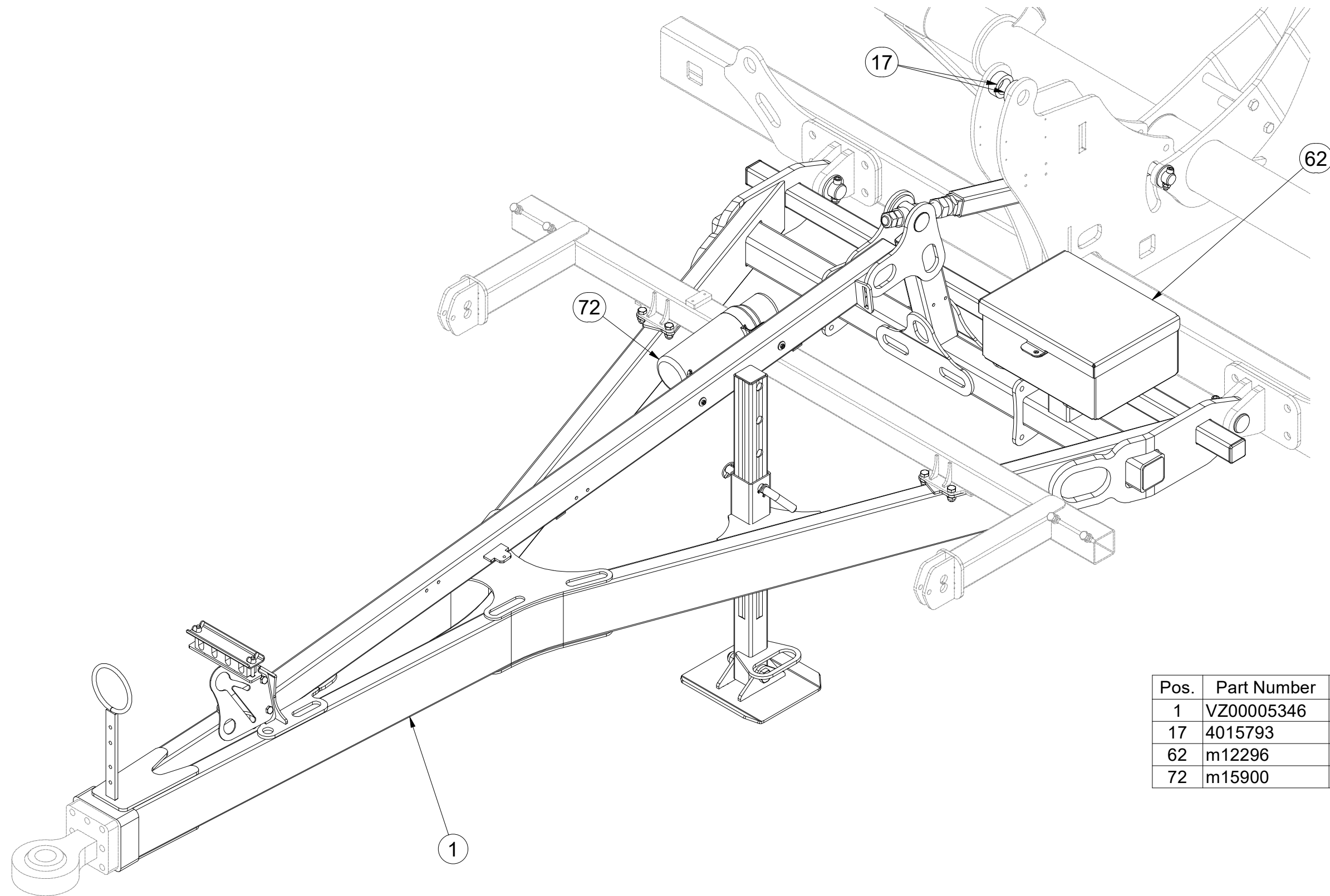

Pos.	Part Number	Pcs.
1	VZ00005346	1
17	4015793	2
62	m12296	1
72	m15900	1

ⒸZ OJ MONT

Ⓓ DEICHSEL MONTIERT

Ⓕ TIMON MONTÉ

VZ00005470

ⒸB MONT DRAWBAR

Ⓔ ДЫШЛО МОНТ.

ⒼL DYSZEL MONT

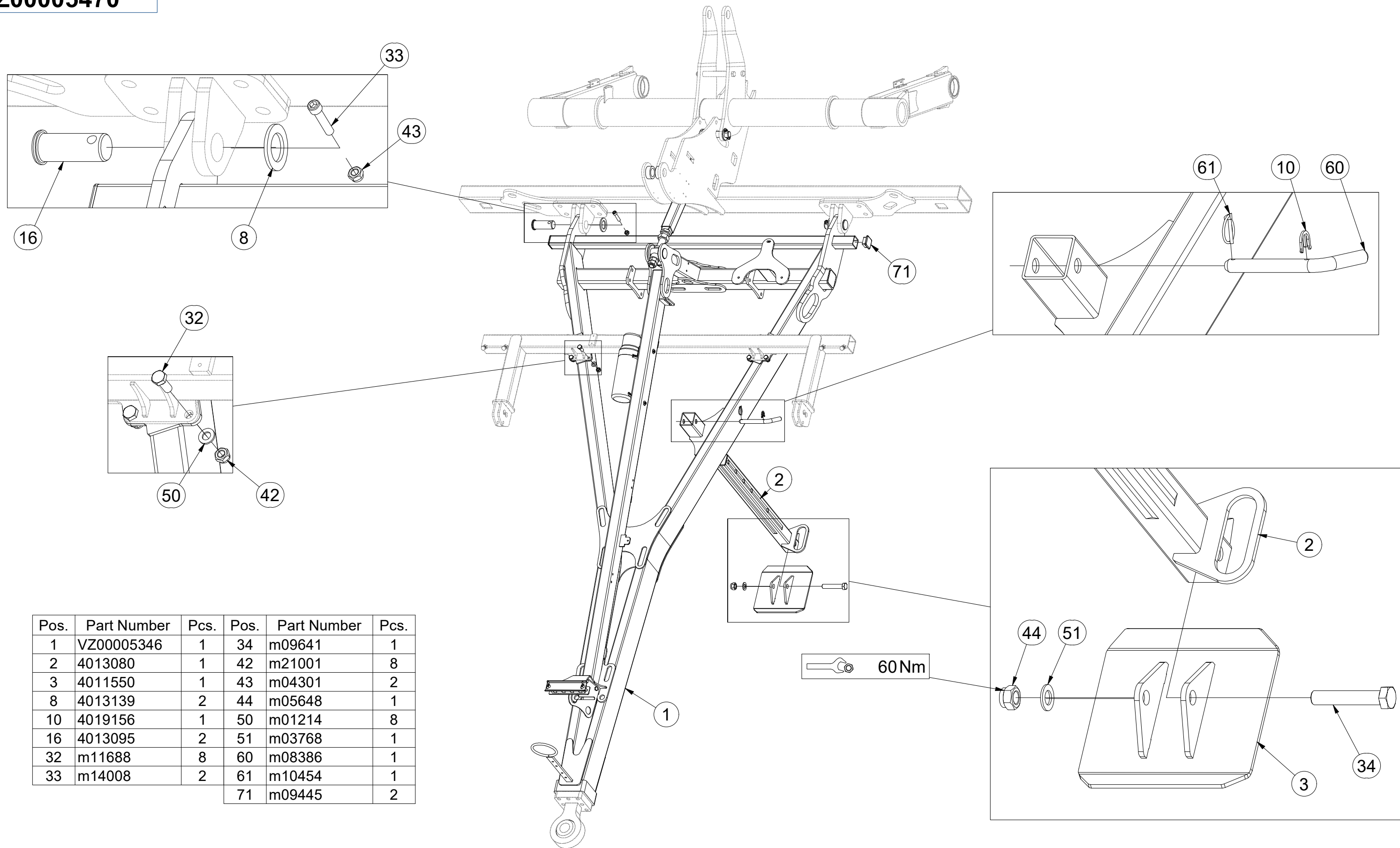

Pos.	Part Number	Pcs.	Pos.	Part Number	Pcs.
1	VZ00005346	1	34	m09641	1
2	4013080	1	42	m21001	8
3	4011550	1	43	m04301	2
8	4013139	2	44	m05648	1
10	4019156	1	50	m01214	8
16	4013095	2	51	m03768	1
32	m11688	8	60	m08386	1
33	m14008	2	61	m10454	1
			71	m09445	2

ⒸZ OJ MONT

Ⓓ DEICHSEL MONTIERT

Ⓕ TIMON MONTÉ

ⒼB MONT DRAWBAR

ⒺU ДЫШЛО МОНТ.

ⒽL DYSZEL MONT



VZ00005470

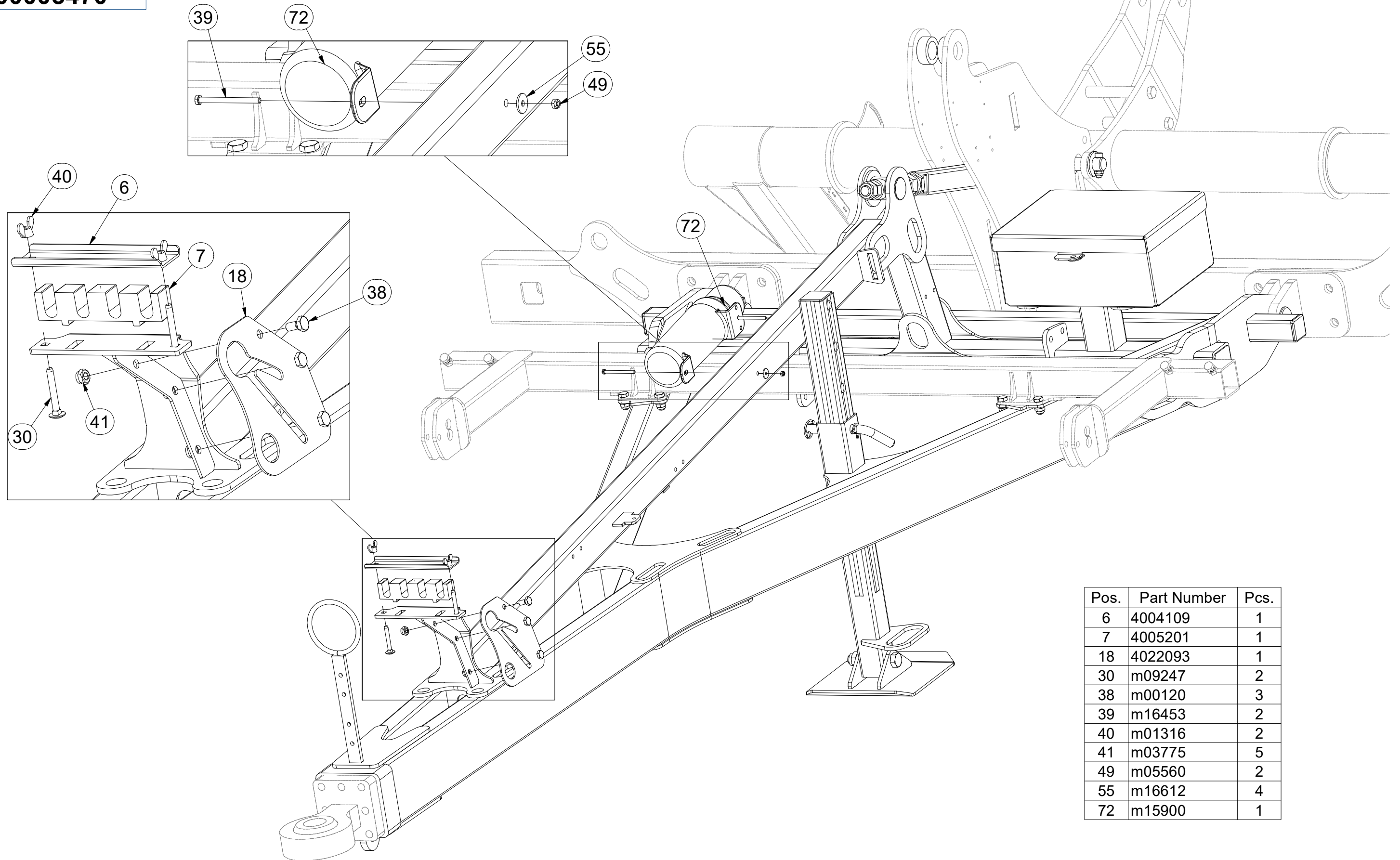

Pos.	Part Number	Pcs.
6	4004109	1
7	4005201	1
18	4022093	1
30	m09247	2
38	m00120	3
39	m16453	2
40	m01316	2
41	m03775	5
49	m05560	2
55	m16612	4
72	m15900	1

ⒸZ OJ MONT

Ⓓ DEICHSEL MONTIERT

Ⓕ TIMON MONTÉ

VZ00005470

ⒼB MONT DRAWBAR

ⒺU ДЫШЛО МОНТ.

ⒽL DYSZEL MONT

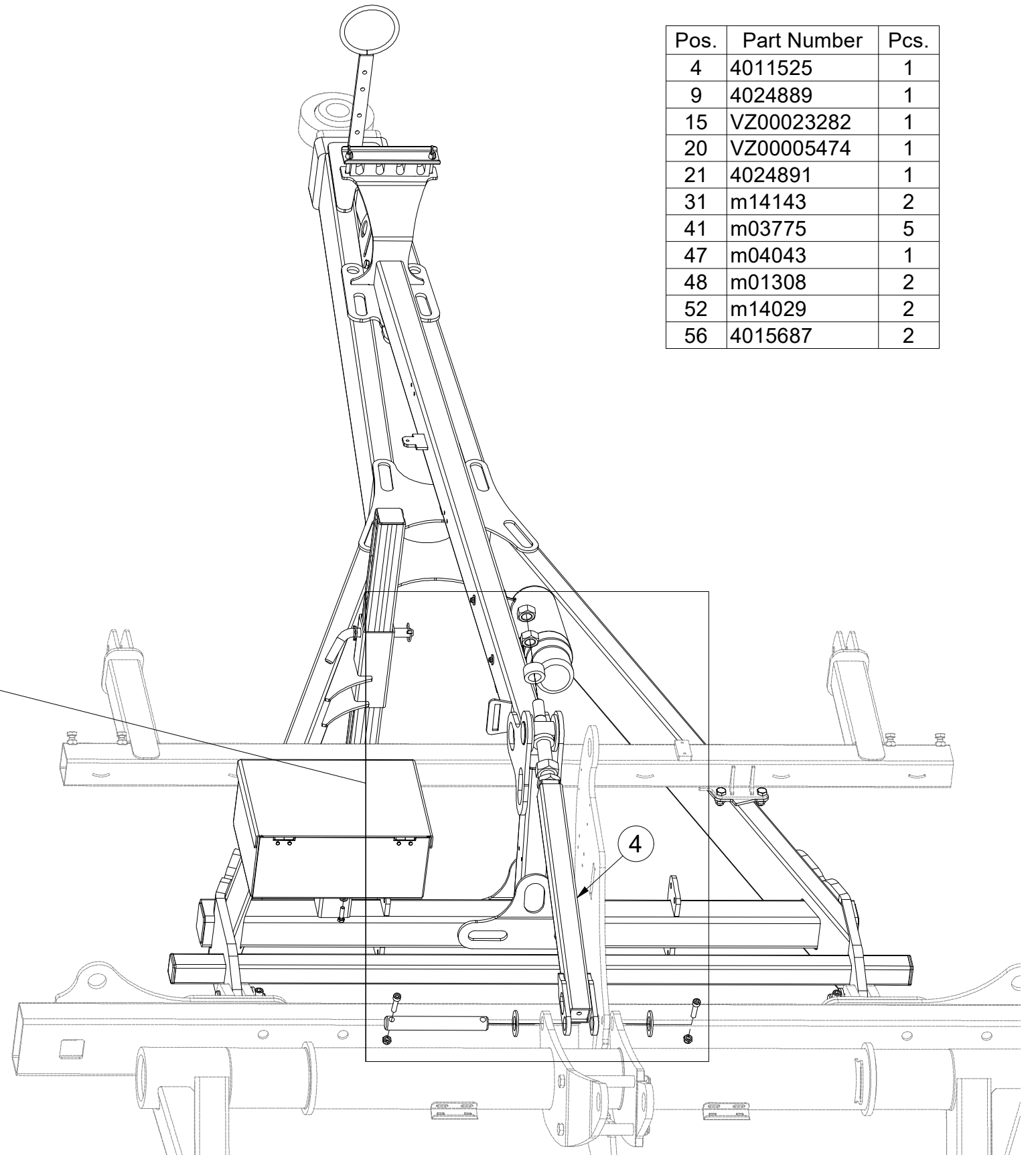
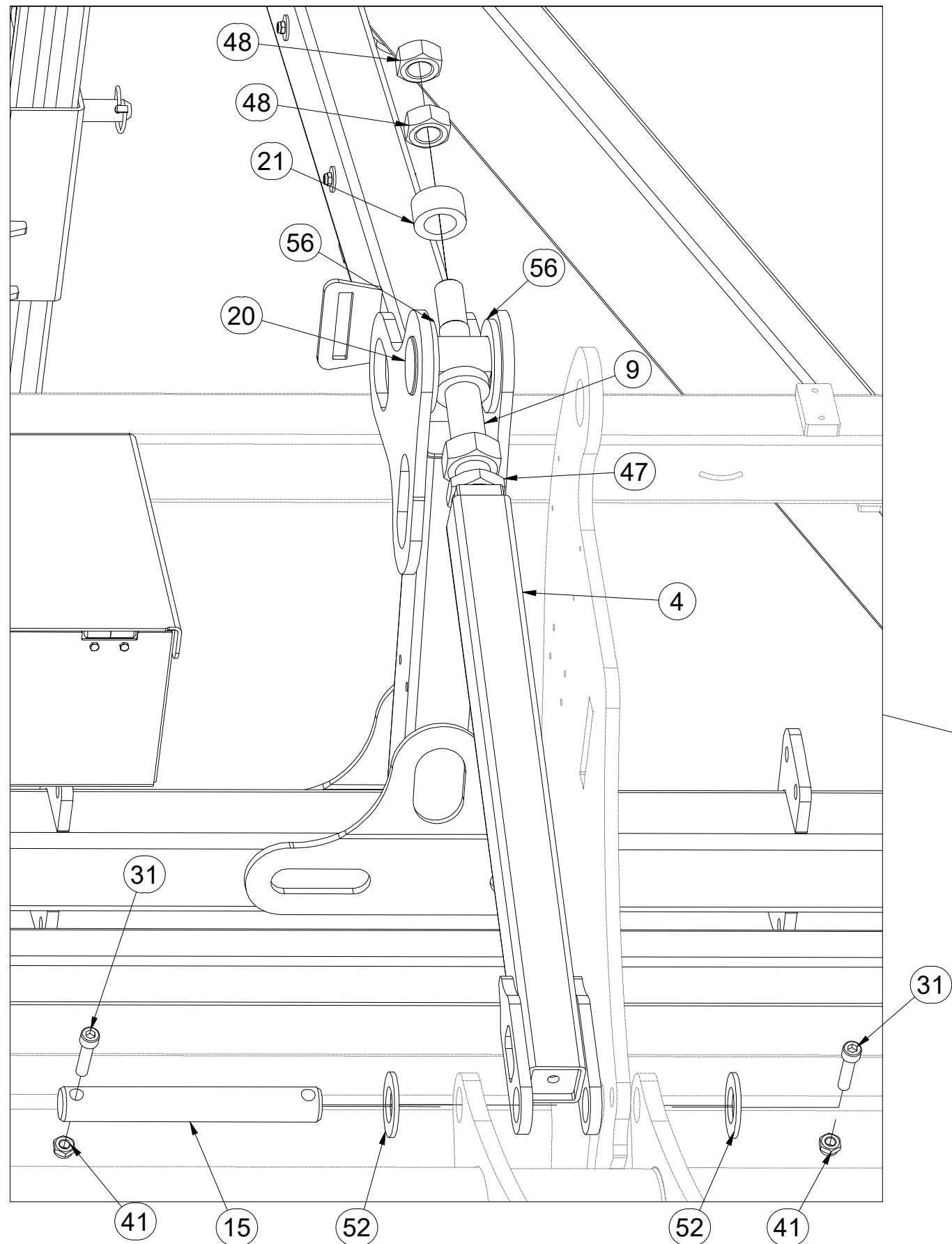

Pos.	Part Number	Pcs.
4	4011525	1
9	4024889	1
15	VZ00023282	1
20	VZ00005474	1
21	4024891	1
31	m14143	2
41	m03775	5
47	m04043	1
48	m01308	2
52	m14029	2
56	4015687	2

ⒸZ OJ MONT

Ⓓ DEICHSEL MONTIERT

Ⓕ F TIMON MONTÉ

ⒼB MONT DRAWBAR

Ⓔ RU ДЫШЛО МОНТ.

ⒼL DYSZEL MONT



VZ00005470

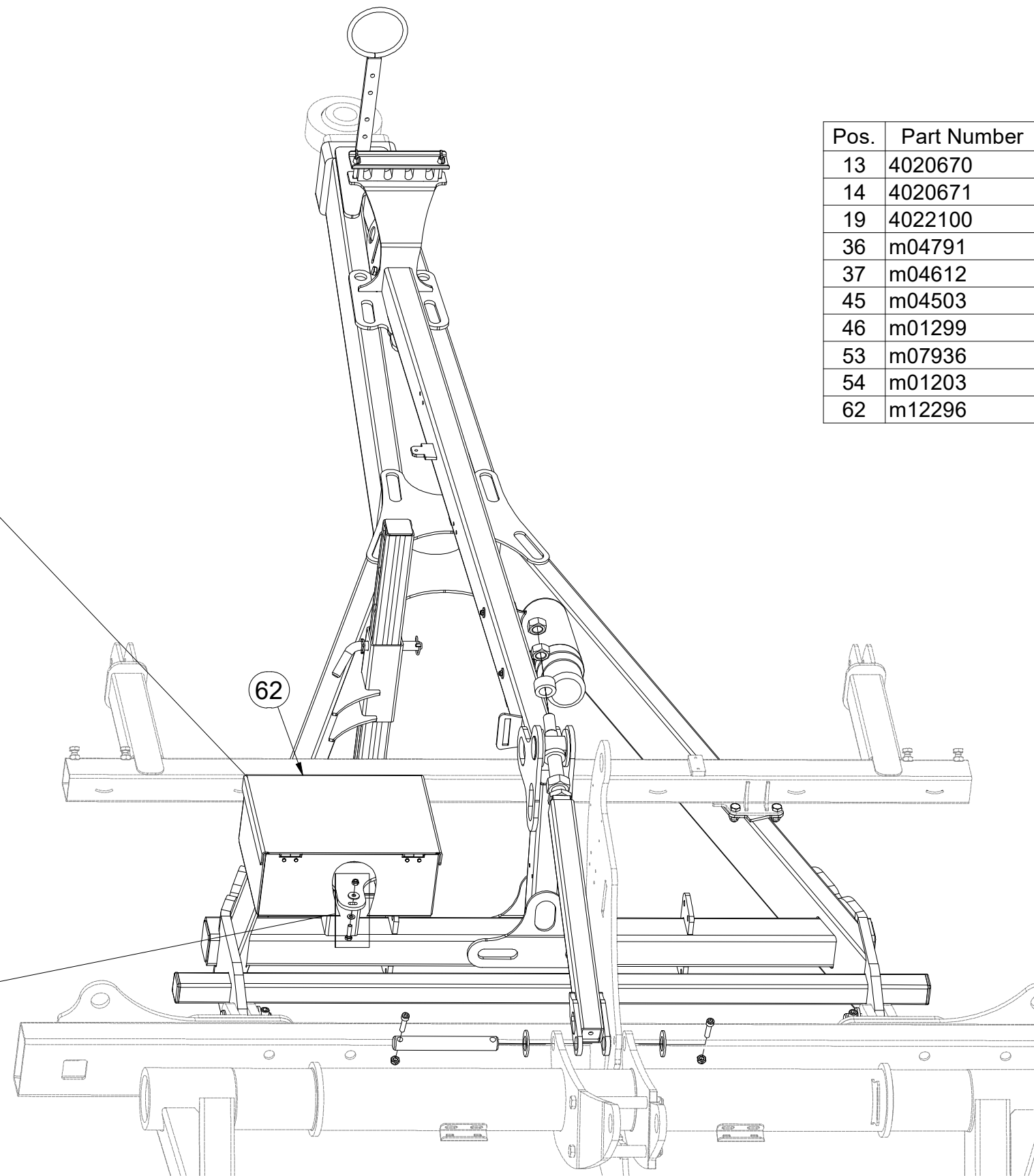
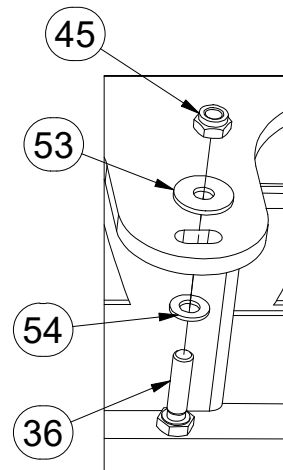
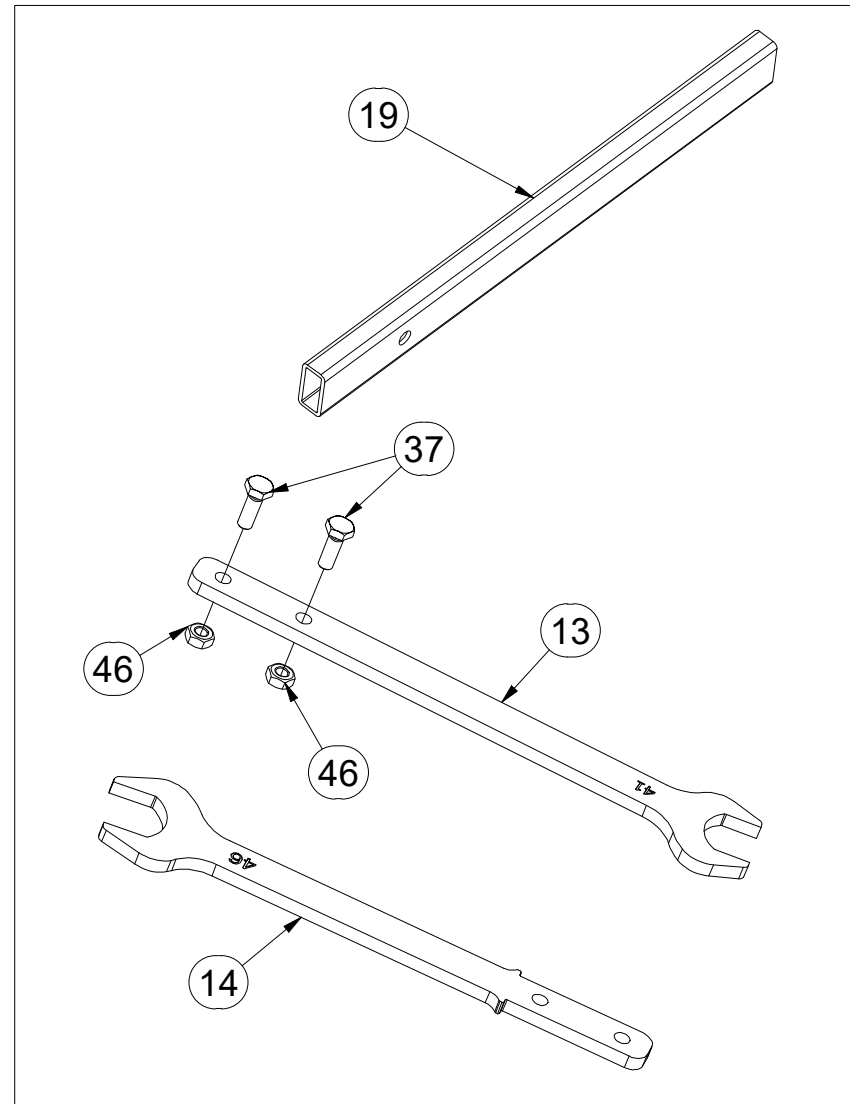

Pos.	Part Number	Pcs.
13	4020670	1
14	4020671	1
19	4022100	1
36	m04791	3
37	m04612	2
45	m04503	3
46	m01299	2
53	m07936	3
54	m01203	3
62	m12296	1

Ⓒ SADA TAŽNÉHO OKA

Ⓓ ZUGÖSESATZ

Ⓕ KIT DE L'ŒILLET DE TRACTION

Ⓖ TOWING LUG SET

Ⓡ КОМПЛЕКТ ТЯГОВОГО ДЫШЛА

Ⓟ ZESTAW UCHA HOLOWNICZEGO



4013531

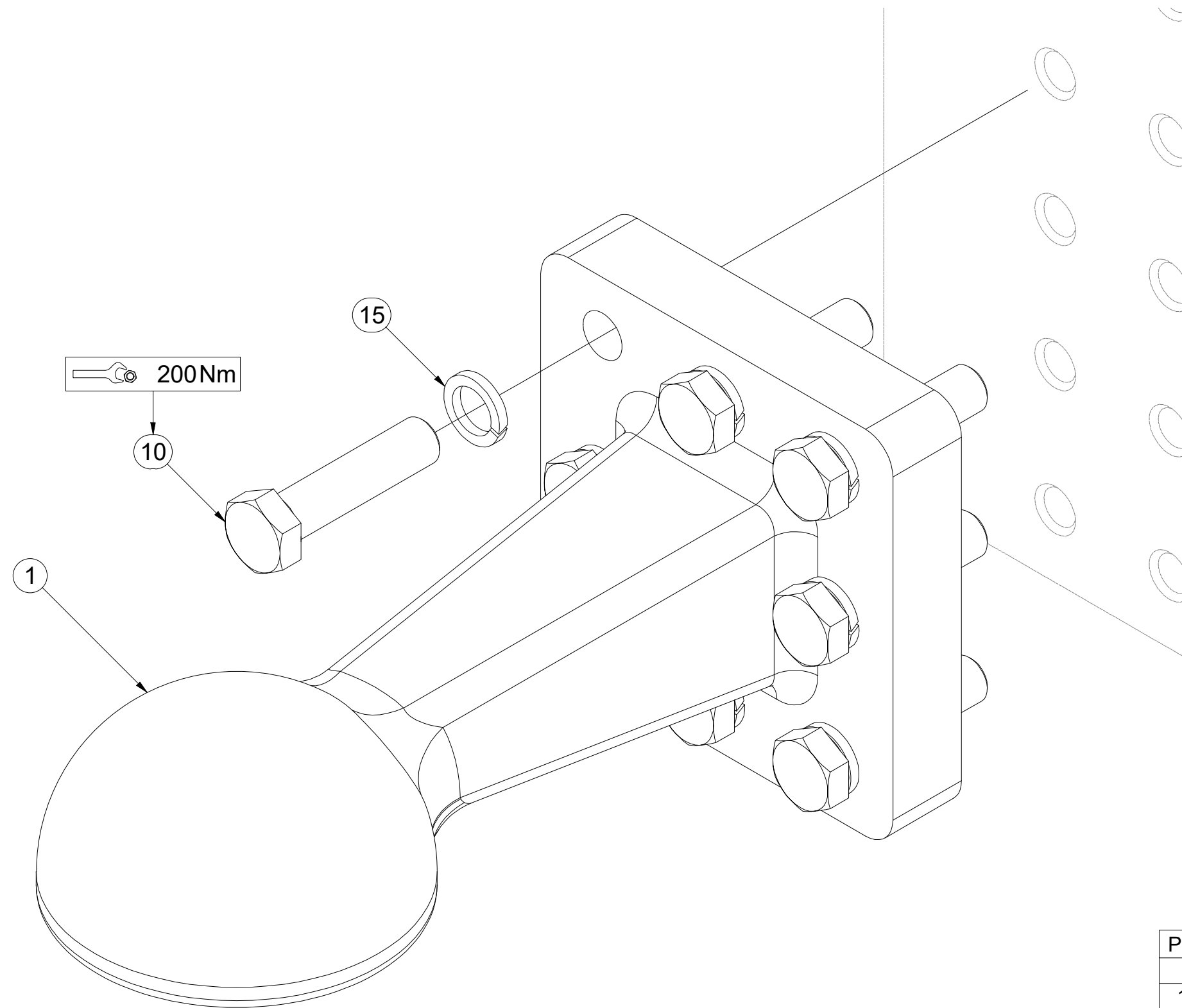

Pos.	Part Number	Pcs.
1	m13262	1
10	m21355	8
15	m02157	8

Ⓒ SADA KYPŘIČŮ STOP

Ⓓ SPURENLOCKERERSATZ

Ⓕ KIT DE CULTIVATEURS DE TRACES

Ⓖ SET OF TRACK CULTIVATORS

Ⓡ КОМПЛЕКТ РЫХЛИТЕЛЕЙ КОЛЕИ

Ⓟ ZESTAW SPULCHNIACZY ŚLADÓW



3009603

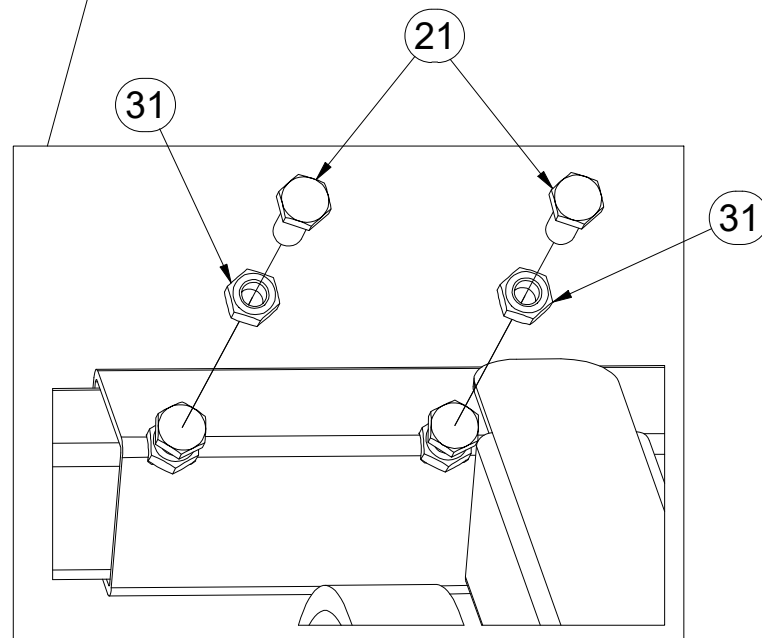
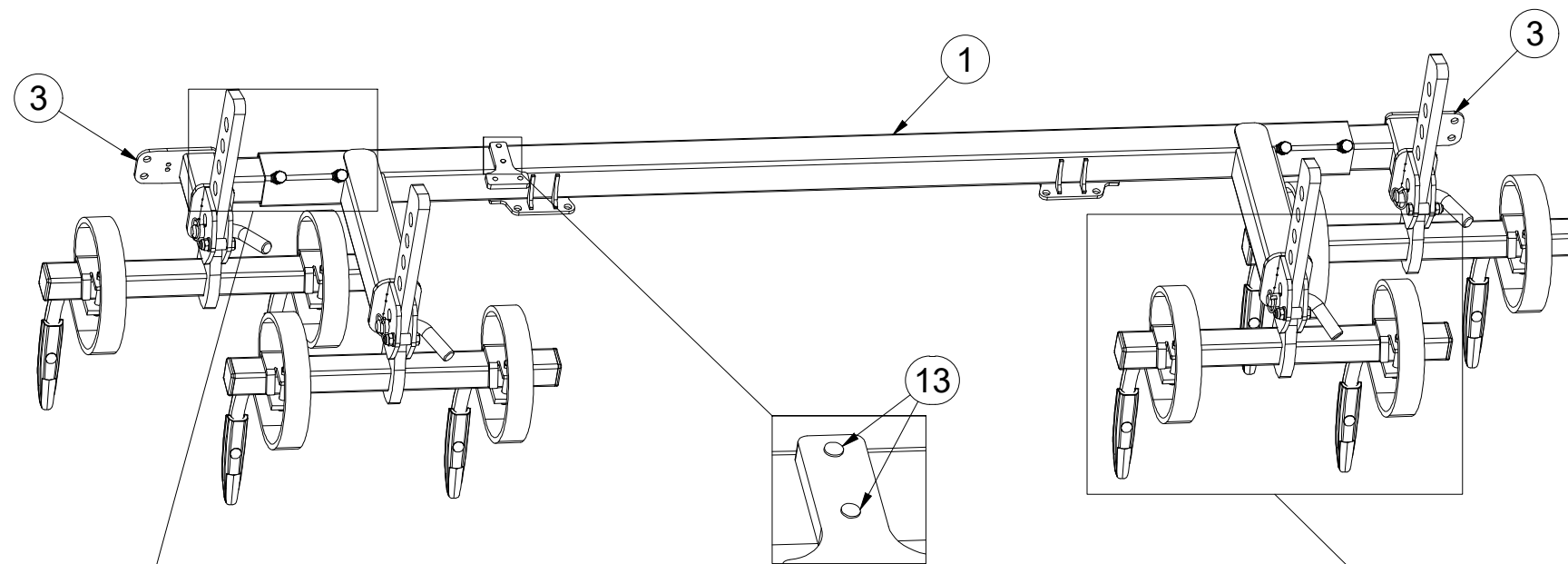

Pos.	Part Number	Pcs.
1	VZ00020138	1
2	3005999	4
3	3009560	2
4	4011438	8
5	VZ00020303	4
10	m08885	4
11	m10454	4
12	m09445	8
13	m11099	2
20	m12626	4
21	m04343	4
30	m04301	4
31	m01305	4
40	m01214	4

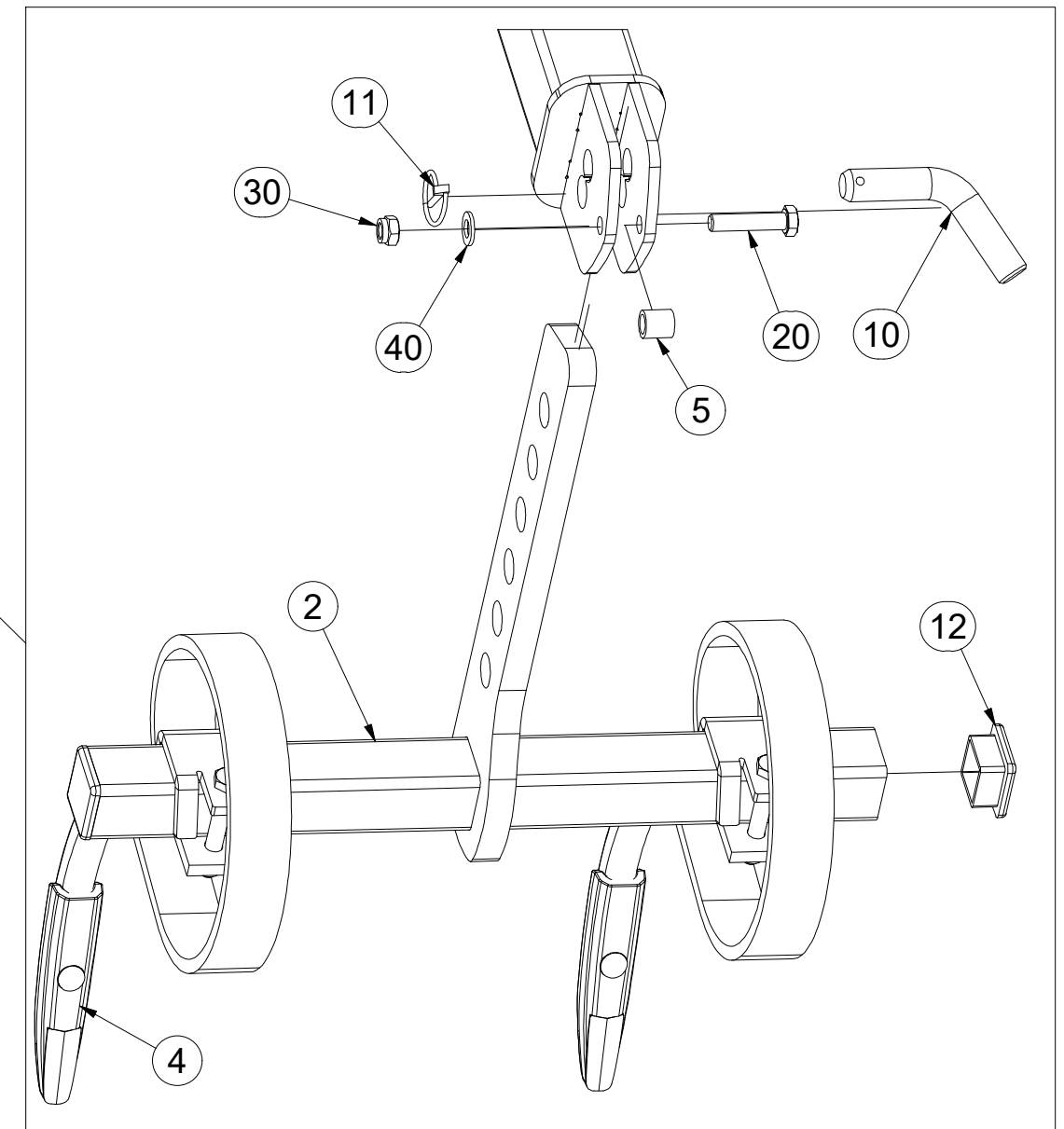

Ⓒ JEDNOTKA PRACOVNÍ DLÁTO

Ⓓ ARBEITSEINHEIT MEISSEL

Ⓕ UNITÉ DE TRAVAIL CISEAU

4011438

Ⓖ WORKING CHISEL UNIT

Ⓡ РАБОЧИЙ УЗЕЛ ЧИЗЕЛЬ

Ⓟ JEDNOSTKA ROBOCZA DŁUTO

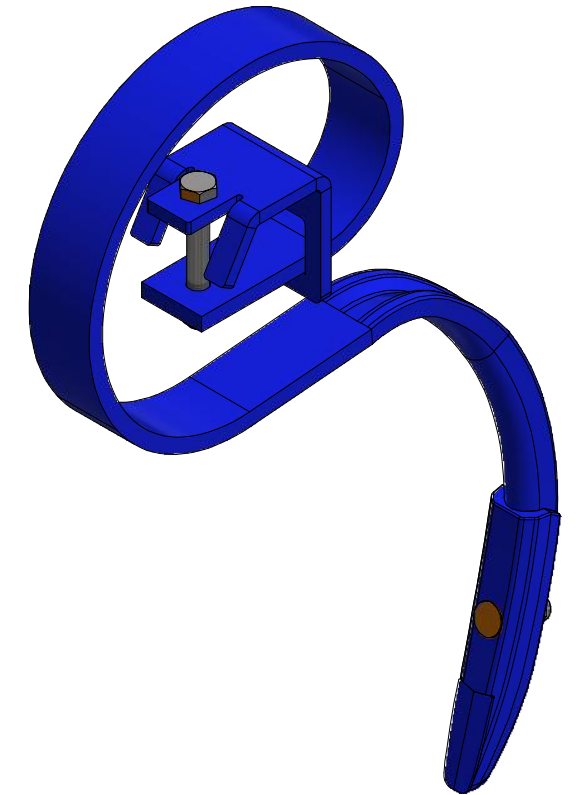
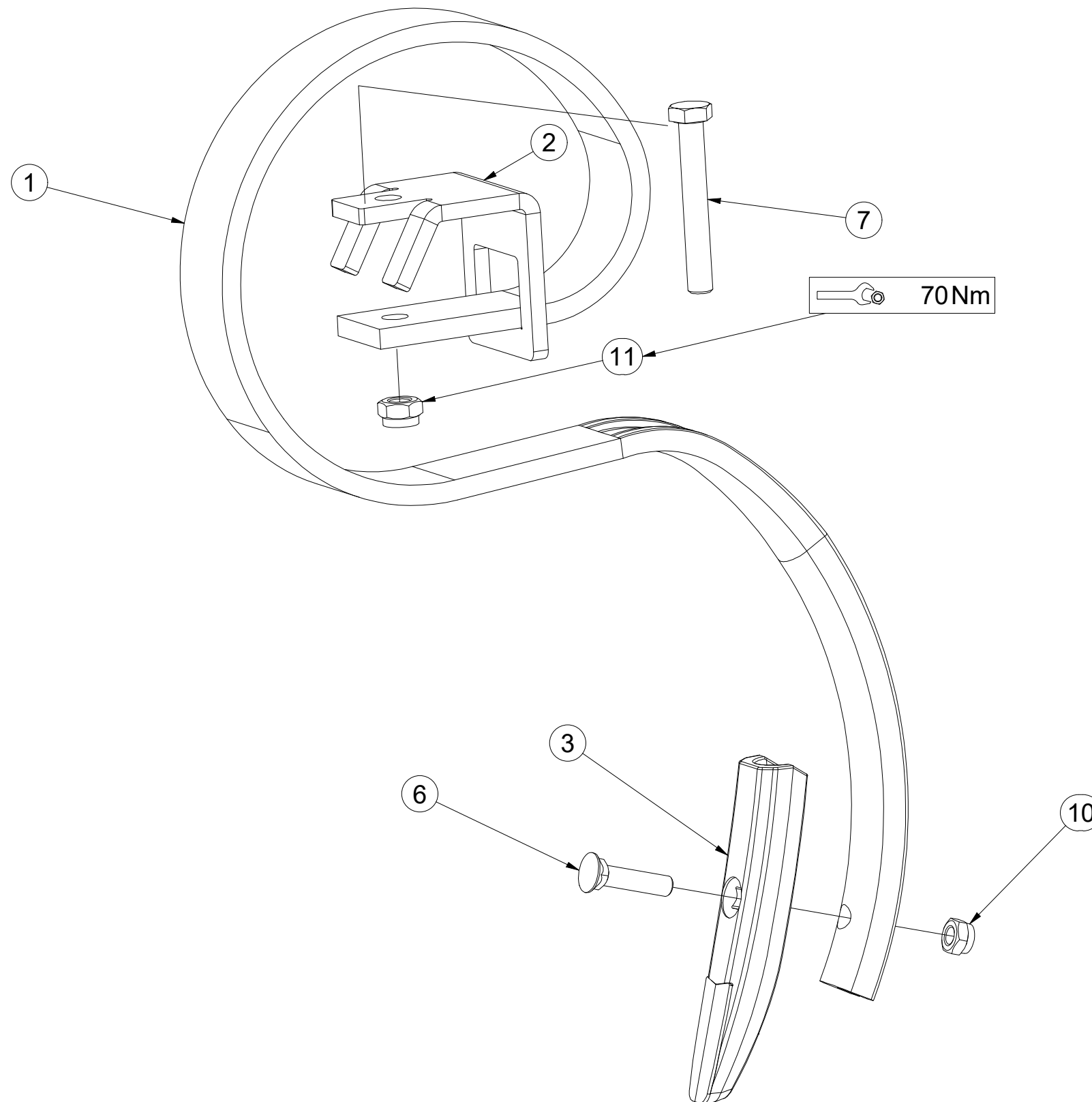

Pos.	Part Number	Pcs.
1	9004270	1
2	4023484	1
3	4011647	1
6	m16625	1
7	m11904	1
10	m11530	1
11	m04301	1

Ⓒ SADA FLEXIBOARDŮ - PŘEDNÍ

Ⓓ FLEXIBOARDSATZ - VORNE

Ⓕ KIT DE FLEXIBOARDS - AVANT

Ⓖ FLEXIBOARD SET - FRONT

Ⓡ КОМПЛЕКТ FLEXIBOARD - ПЕРЕДНИЙ

Ⓟ ZESTAW FLEXIBOARDOW - PRZEDNI



VZ00017878

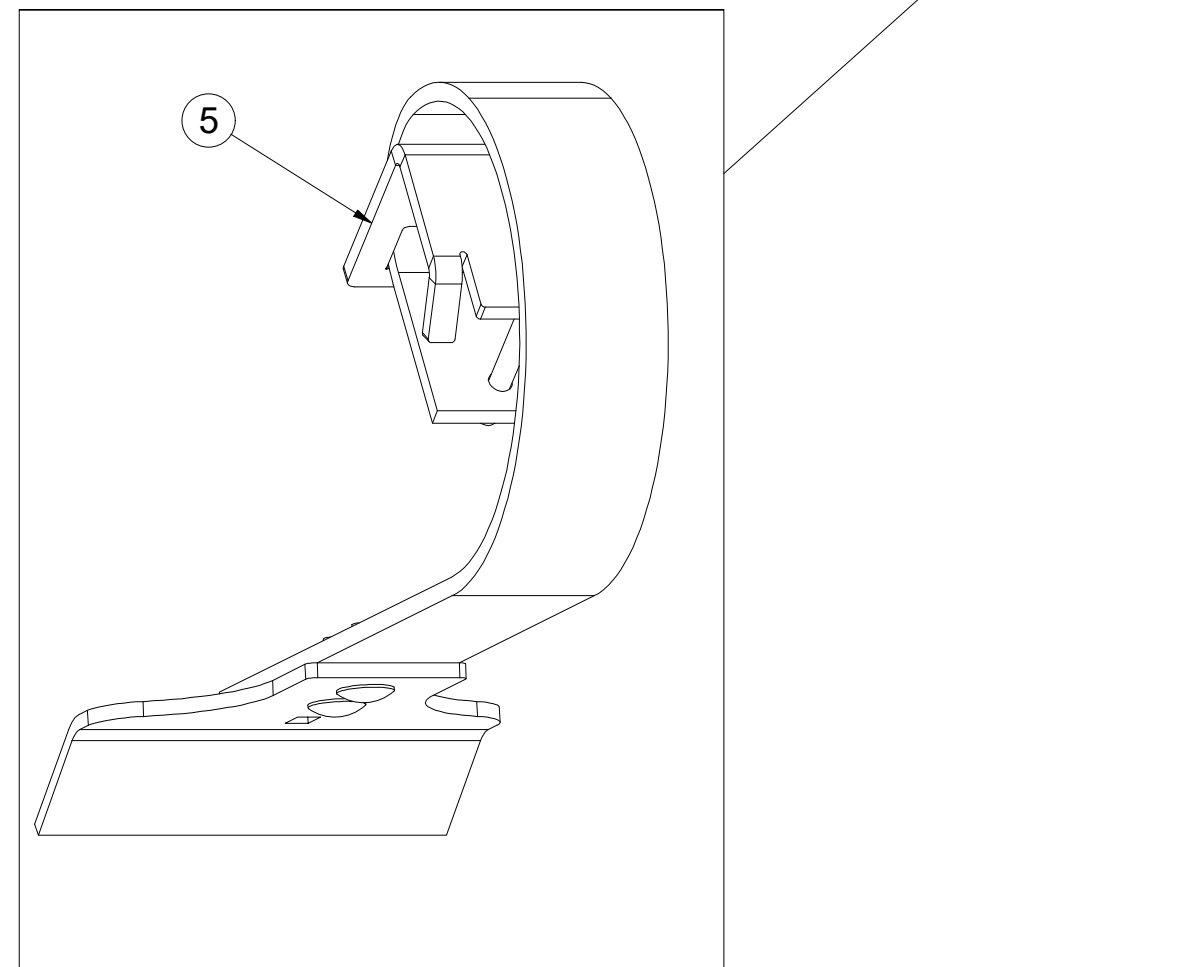
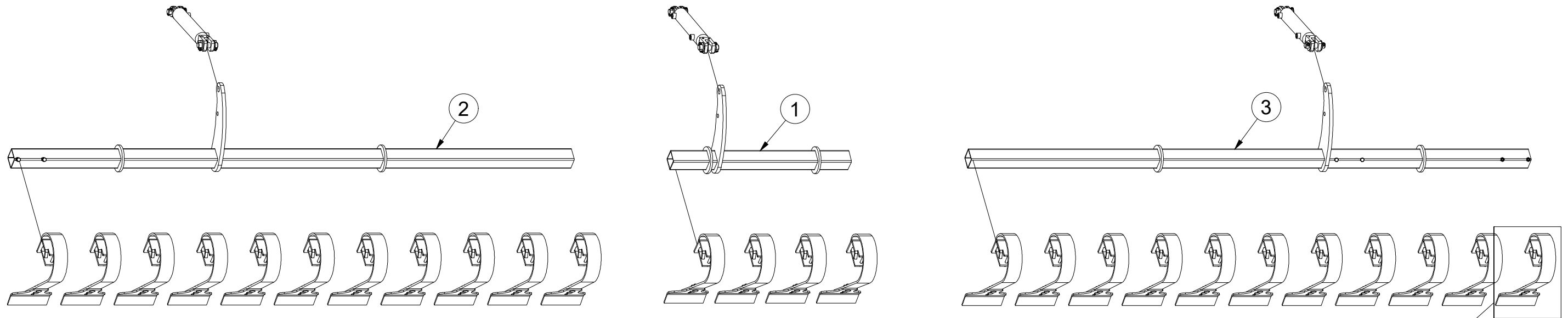

Pos.	Part Number	Pcs.
1	VZ00016608	1
2	VZ00017880	1
3	VZ00017879	1
5	4013079	26

Ⓒ SADA FLEXIBOARDŮ - PŘEDNÍ

Ⓓ FLEXIBOARDSATZ - VORNE

Ⓕ KIT DE FLEXIBOARDS - AVANT

Ⓖ FLEXIBOARD SET - FRONT

Ⓔ КОМПЛЕКТ FLEXIBOARD - ПЕРЕДНИЙ

Ⓗ ZESTAW FLEXIBOARDOW - PRZEDNI



VZ00017878

Pos.	Part Number	Pcs.	Pos.	Part Number	Pcs.	Pos.	Part Number	Pcs.
2	VZ00017880	1	17	VZ00010003	12	36	m01305	4
4	3009103	4	20	m14371	3	37	m04301	28
7	4018110	12	25	m14143	12	38	m13846	16
8	4018126	6	26	m04343	4	45	m14029	12
11	4016312	1	28	m06077	16	46	m01219	32
12	4018112	1	29	m02254	16	47	m02866	9
13	4016313	1	31	m03927	2	48	m01214	2
15	4007639	3	32	m03339	2	50	m12167	6
16	4007584	3	35	m03775	12			

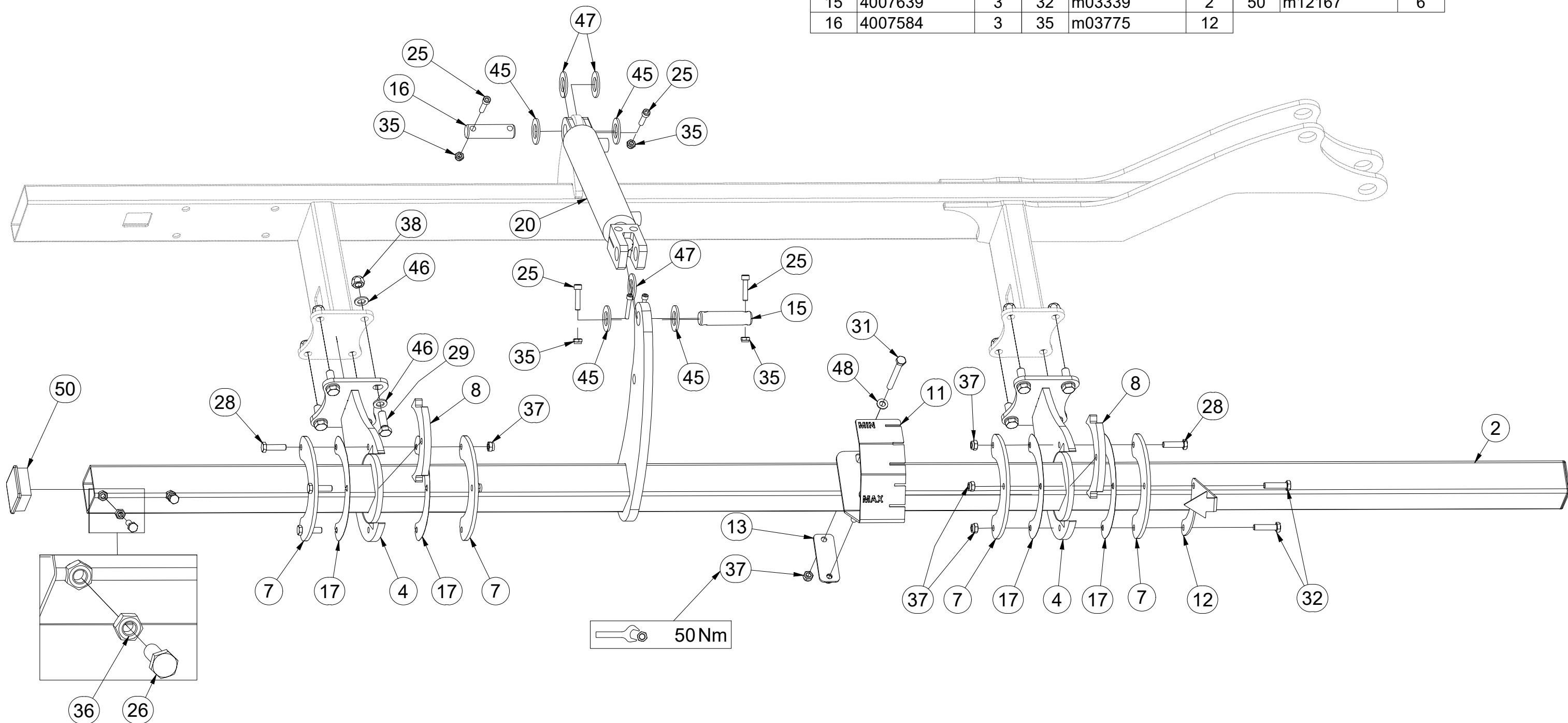

Ⓒ SADA FLEXIBOARDŮ - PŘEDNÍ

Ⓓ FLEXIBOARDSATZ - VORNE

Ⓕ KIT DE FLEXIBOARDS - AVANT

Ⓖ FLEXIBOARD SET - FRONT

Ⓔ КОМПЛЕКТ FLEXIBOARD - ПЕРЕДНИЙ

Ⓗ ZESTAW FLEXIBOARDOW - PRZEDNI



VZ00017878

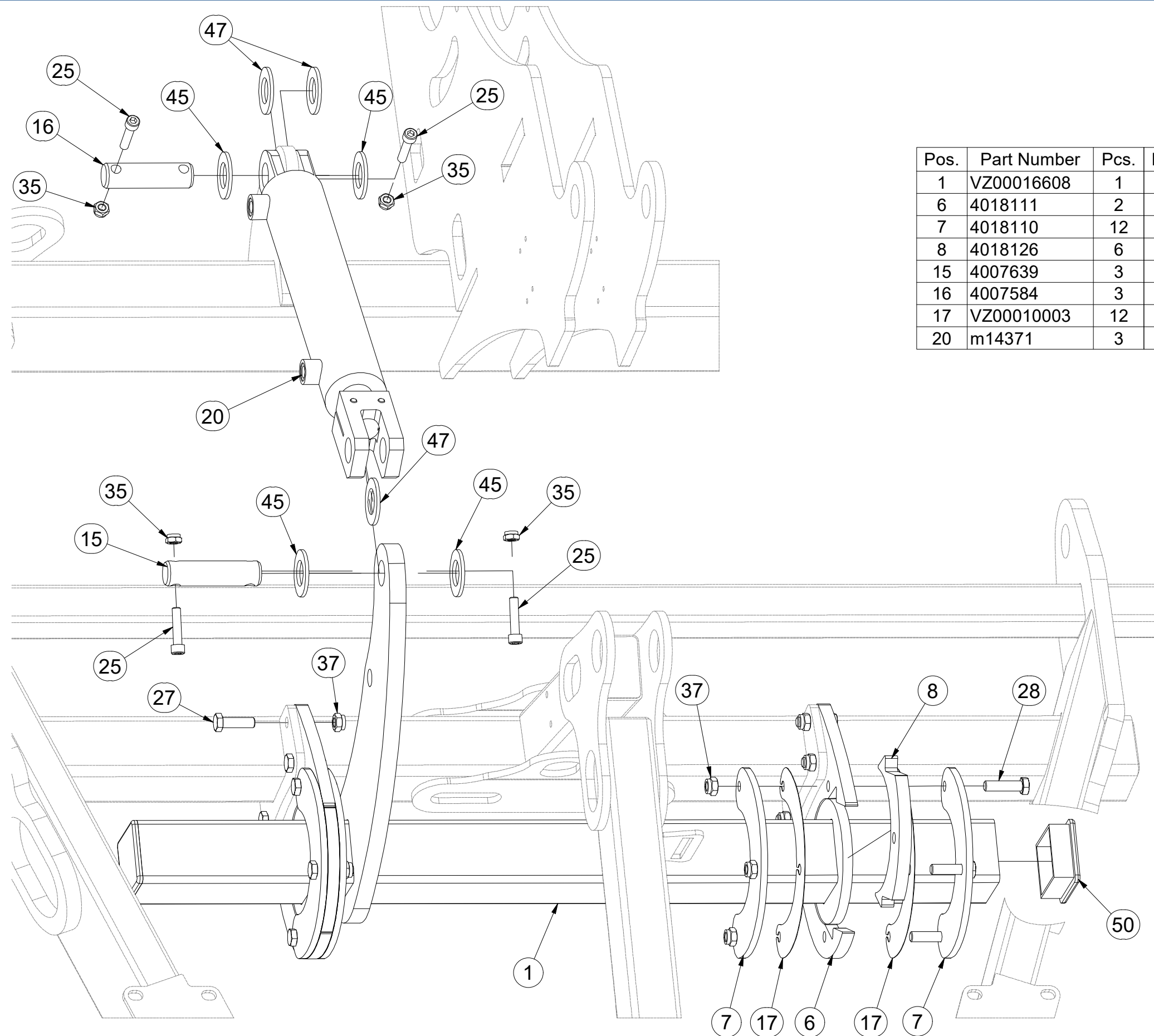

Pos.	Part Number	Pcs.	Pos.	Part Number	Pcs.
1	VZ00016608	1	25	m14143	12
6	4018111	2	27	m03926	8
7	4018110	12	28	m06077	16
8	4018126	6	35	m03775	12
15	4007639	3	37	m04301	28
16	4007584	3	45	m14029	12
17	VZ00010003	12	47	m02866	9
20	m14371	3	50	m12167	6

Ⓒ SADA FLEXIBOARDŮ - PŘEDNÍ

Ⓓ FLEXIBOARDSATZ - VORNE

Ⓕ KIT DE FLEXIBOARDS - AVANT

Ⓖ FLEXIBOARD SET - FRONT

Ⓡ КОМПЛЕКТ FLEXIBOARD - ПЕРЕДНИЙ

Ⓟ ZESTAW FLEXIBOARDOW - PRZEDNI



VZ00017878

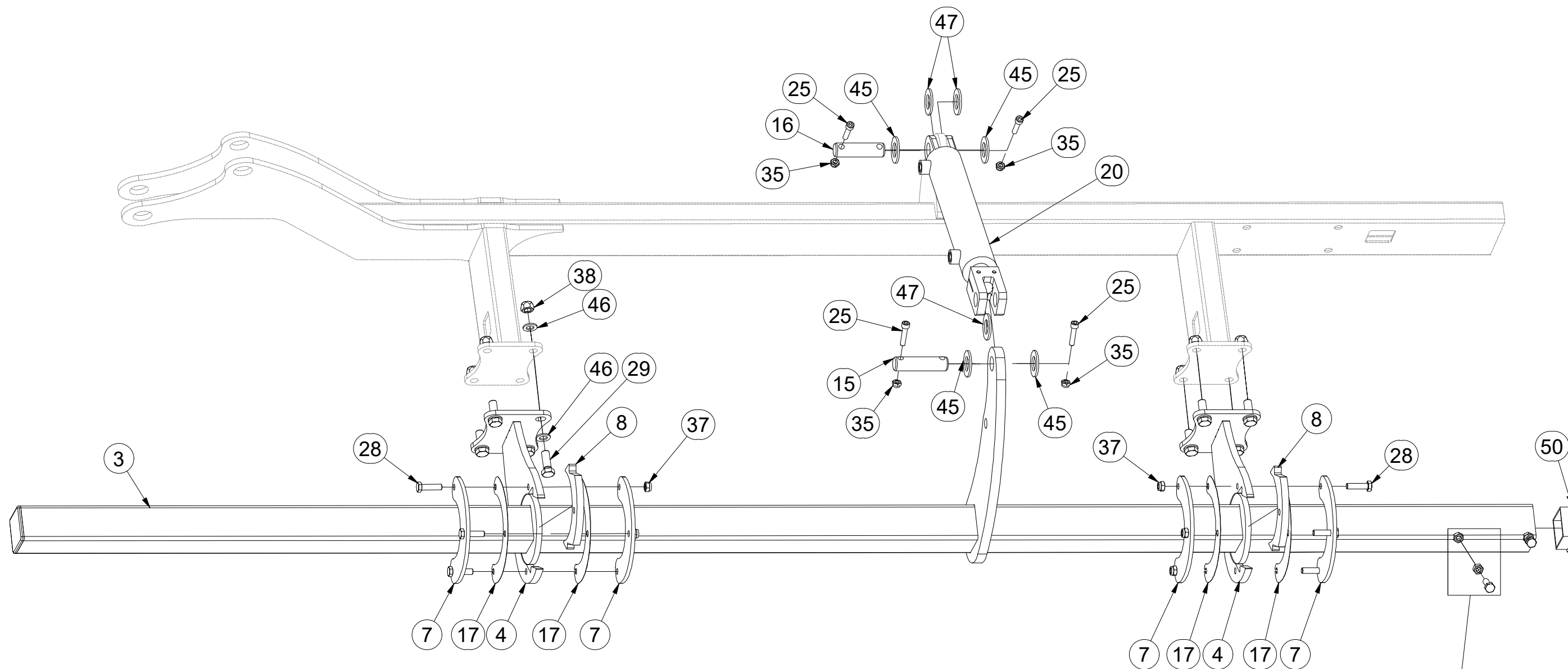

Pos.	Part Number	Pcs.	Pos.	Part Number	Pcs.	Pos.	Part Number	Pcs.
3	VZ00017879	1	20	m14371	3	37	m04301	28
4	3009103	4	25	m14143	12	38	m13846	16
7	4018110	12	26	m04343	4	45	m14029	12
8	4018126	6	28	m06077	16	46	m01219	32
15	4007639	3	29	m02254	16	47	m02866	9
16	4007584	3	35	m03775	12	50	m12167	6
17	VZ00010003	12	36	m01305	4			

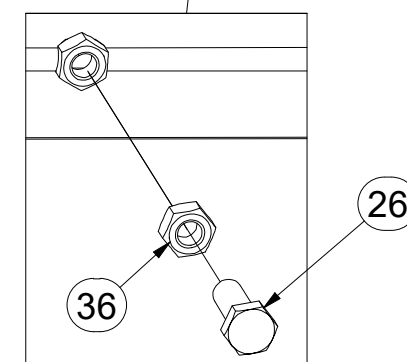

Ⓒ SADA FLEXIBOARDŮ - PŘEDNÍ

Ⓓ FLEXIBOARDSATZ - VORNE

Ⓕ KIT DE FLEXIBOARDS - AVANT

Ⓖ FLEXIBOARD SET - FRONT

Ⓡ КОМПЛЕКТ FLEXIBOARD - ПЕРЕДНИЙ

Ⓟ ZESTAW FLEXIBOARDOW - PRZEDNI



VZ00017878

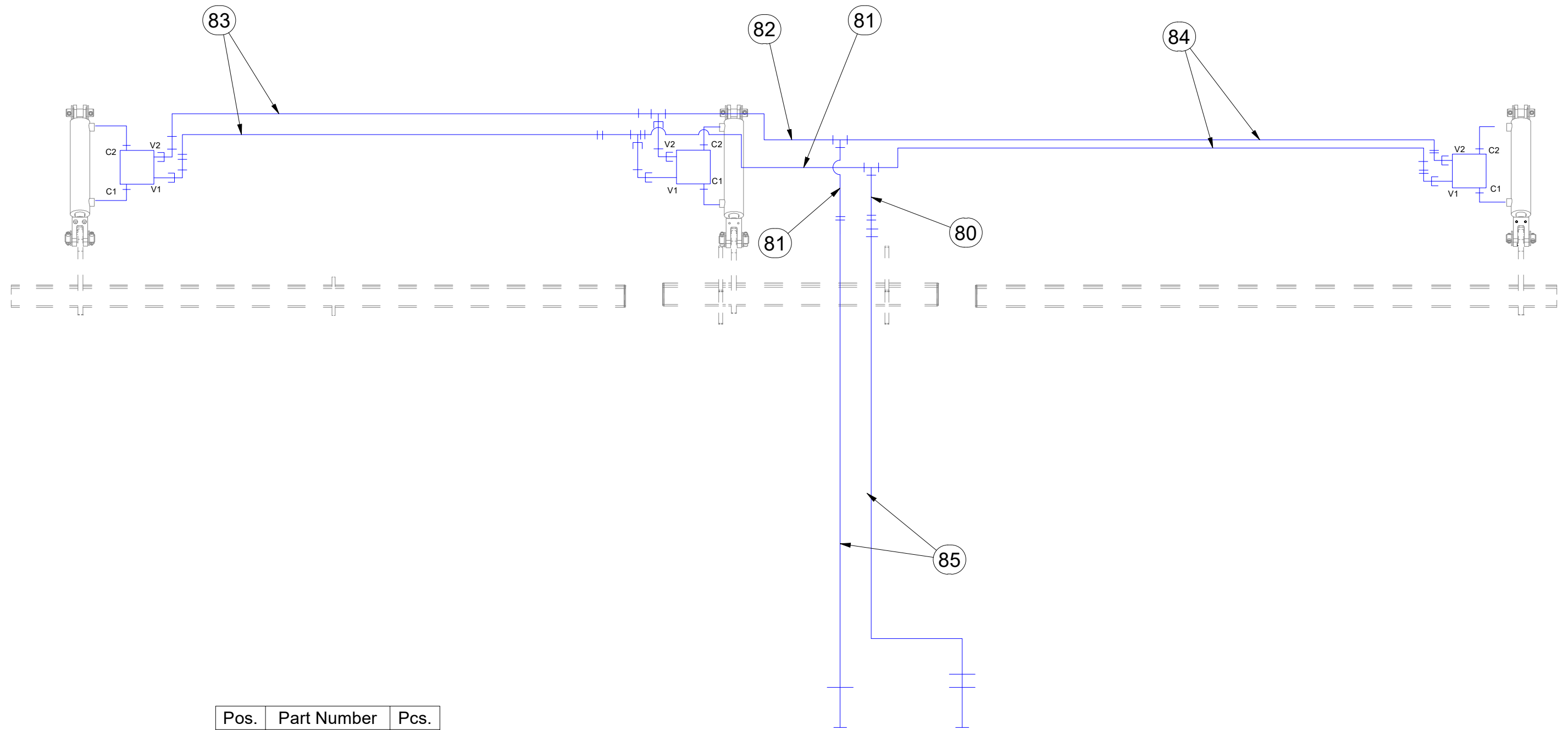

Pos.	Part Number	Pcs.
80	m09627	1
81	m11000	2
82	m11126	1
83	m07650	2
84	m08000	2
85	m05216	2

ⒸZ SADA FLEXIBOARDŮ - PŘEDNÍ

Ⓓ FLEXIBOARDSATZ - VORNE

Ⓕ KIT DE FLEXIBOARDS - AVANT

ⒸB FLEXIBOARD SET - FRONT

ⒸU КОМПЛЕКТ FLEXIBOARD - ПЕРЕДНИЙ

ⒸL ZESTAW FLEXIBOARDOW - PRZEDNI



VZ00017878

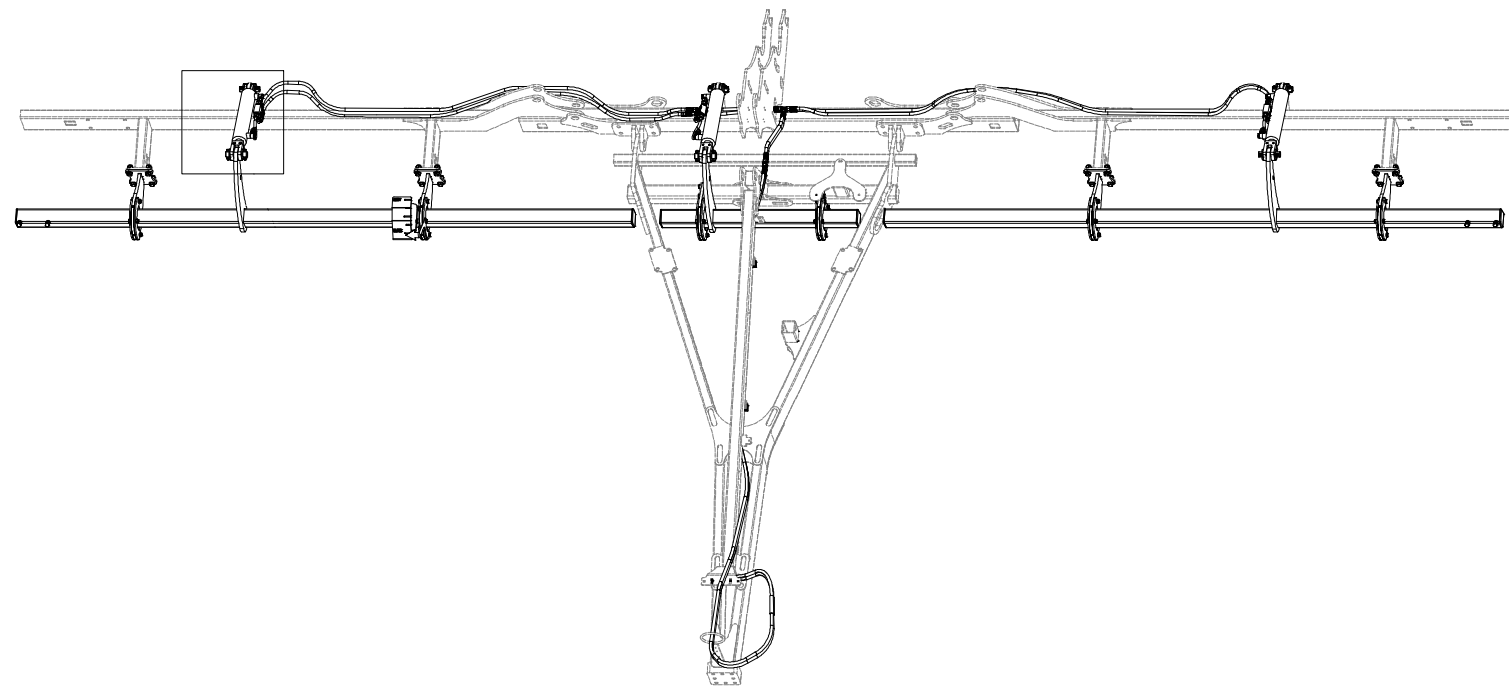

Pos.	Part Number	Pcs.	Pos.	Part Number	Pcs.
14	VZ00023059	3	66	m07654	3
22	m08083	3	67	m22306	3
52	m11253	21	68	m08861	6
59	m08460	6	69	m08862	6
60	m08461	6	72	m06528	6
62	m10649	3	73	m06803	3
63	m10774	3	74	m04024	3
64	m04222	6	83	m07650	2
65	m12442	6			

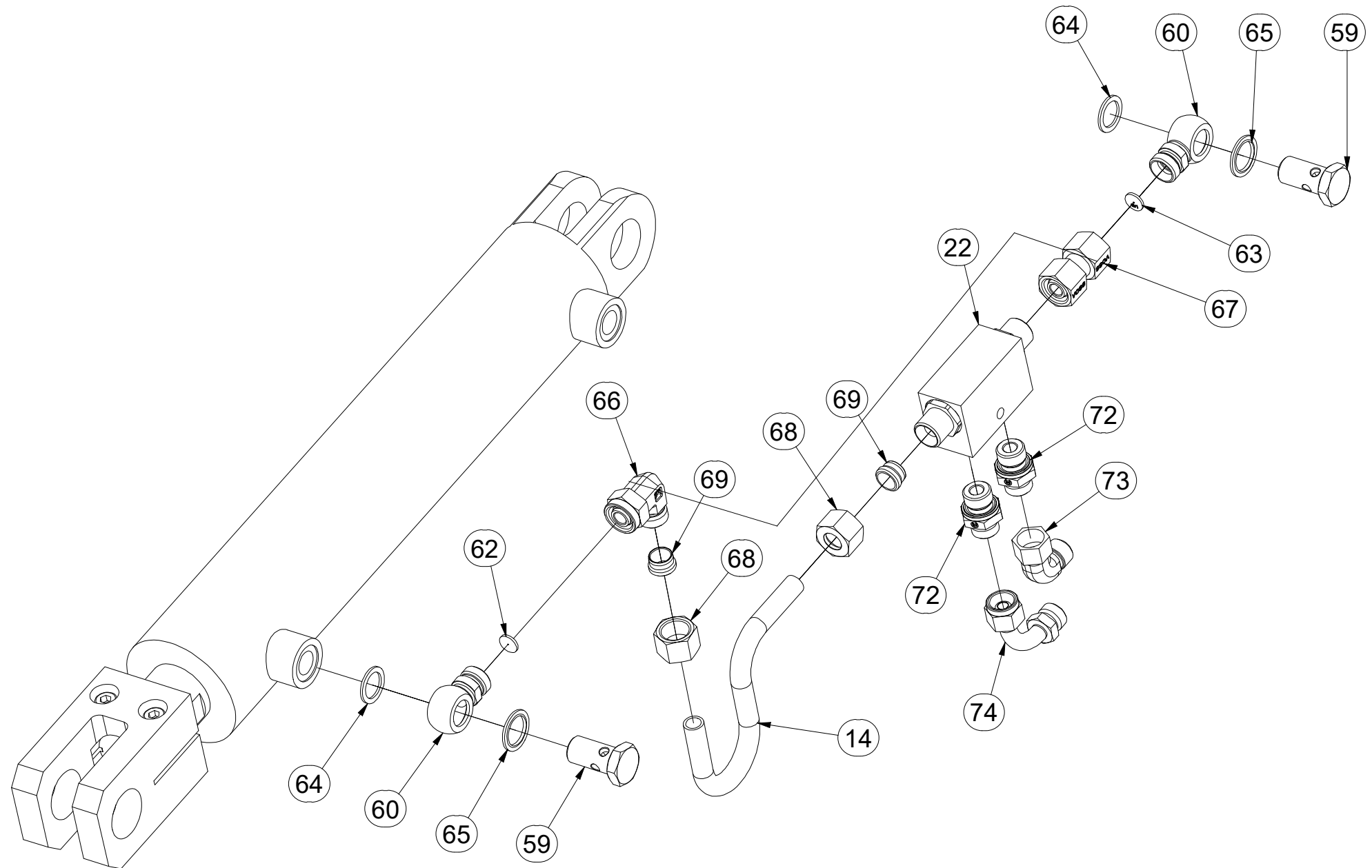
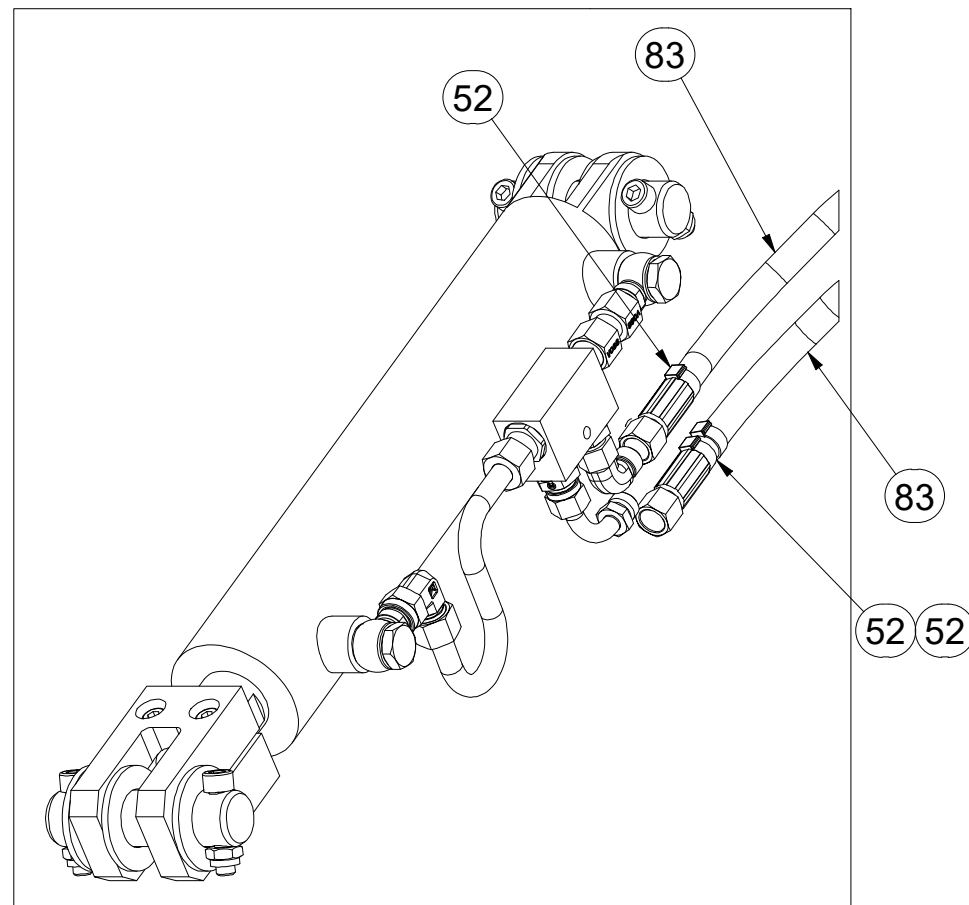

ⒸZ SADA FLEXIBOARDŮ - PŘEDNÍ

Ⓓ FLEXIBOARDSATZ - VORNE

Ⓕ KIT DE FLEXIBOARDS - AVANT

ⒸB FLEXIBOARD SET - FRONT

ⒸU КОМПЛЕКТ FLEXIBOARD - ПЕРЕДНИЙ

ⒸL ZESTAW FLEXIBOARDOW - PRZEDNI



VZ00017878

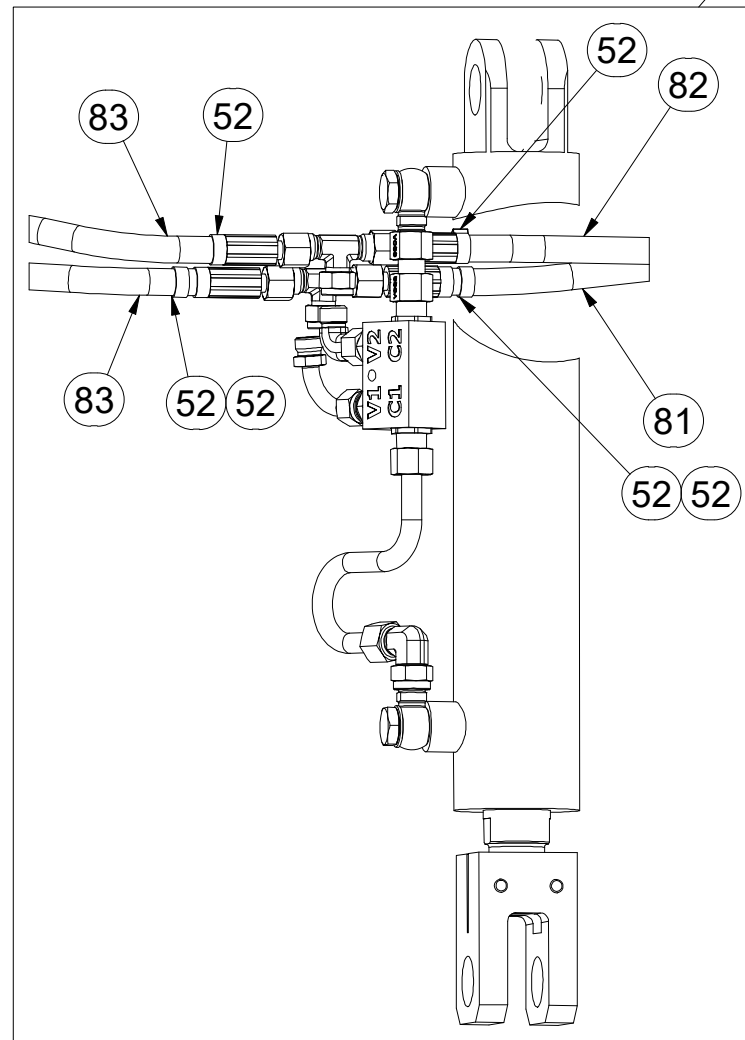
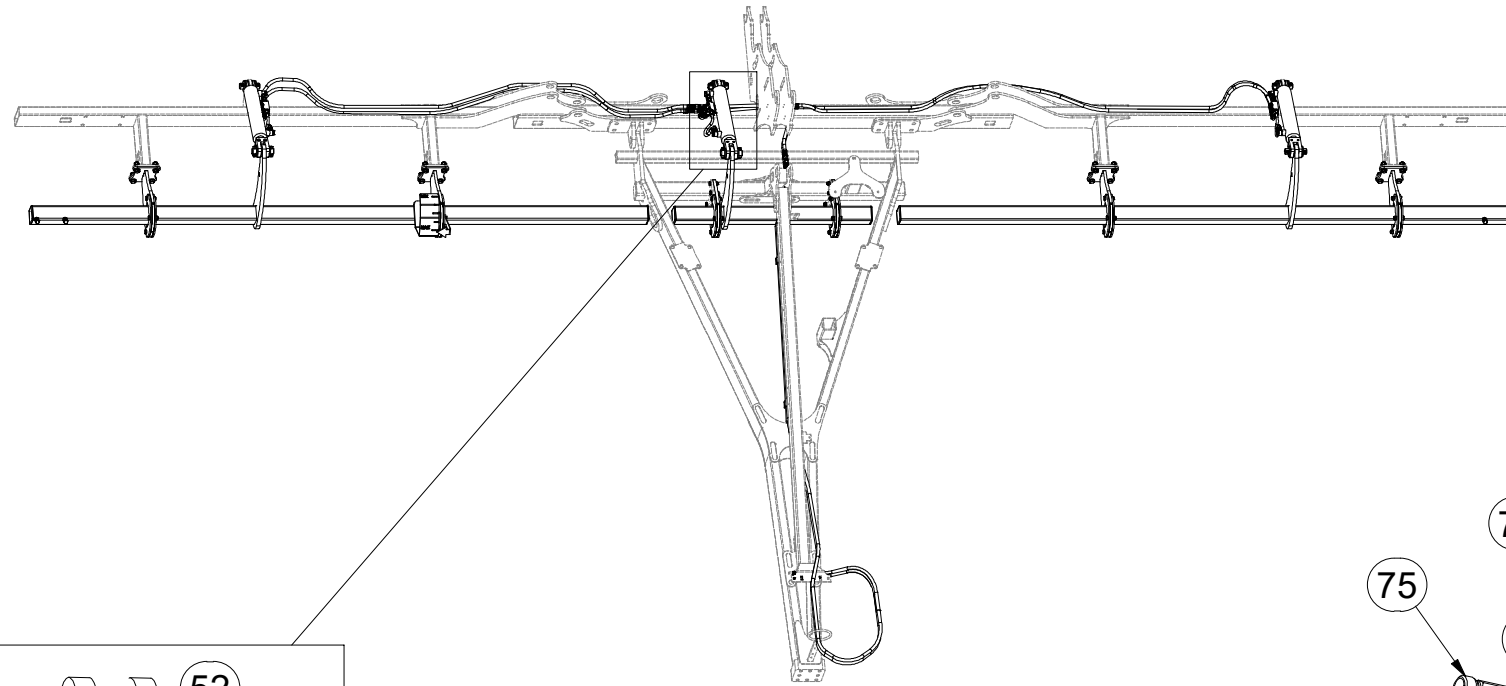

Pos.	Part Number	Pcs.
14	VZ00023059	3
22	m08083	3
52	m11253	21
59	m08460	6
60	m08461	6
62	m10649	3
63	m10774	3
64	m04222	6
65	m12442	6
66	m07654	3
67	m22306	3
68	m08861	6
69	m08862	6
72	m06528	6
73	m06803	3
74	m04024	3
75	m07567	2
81	m11000	2
82	m11126	1
83	m07650	2

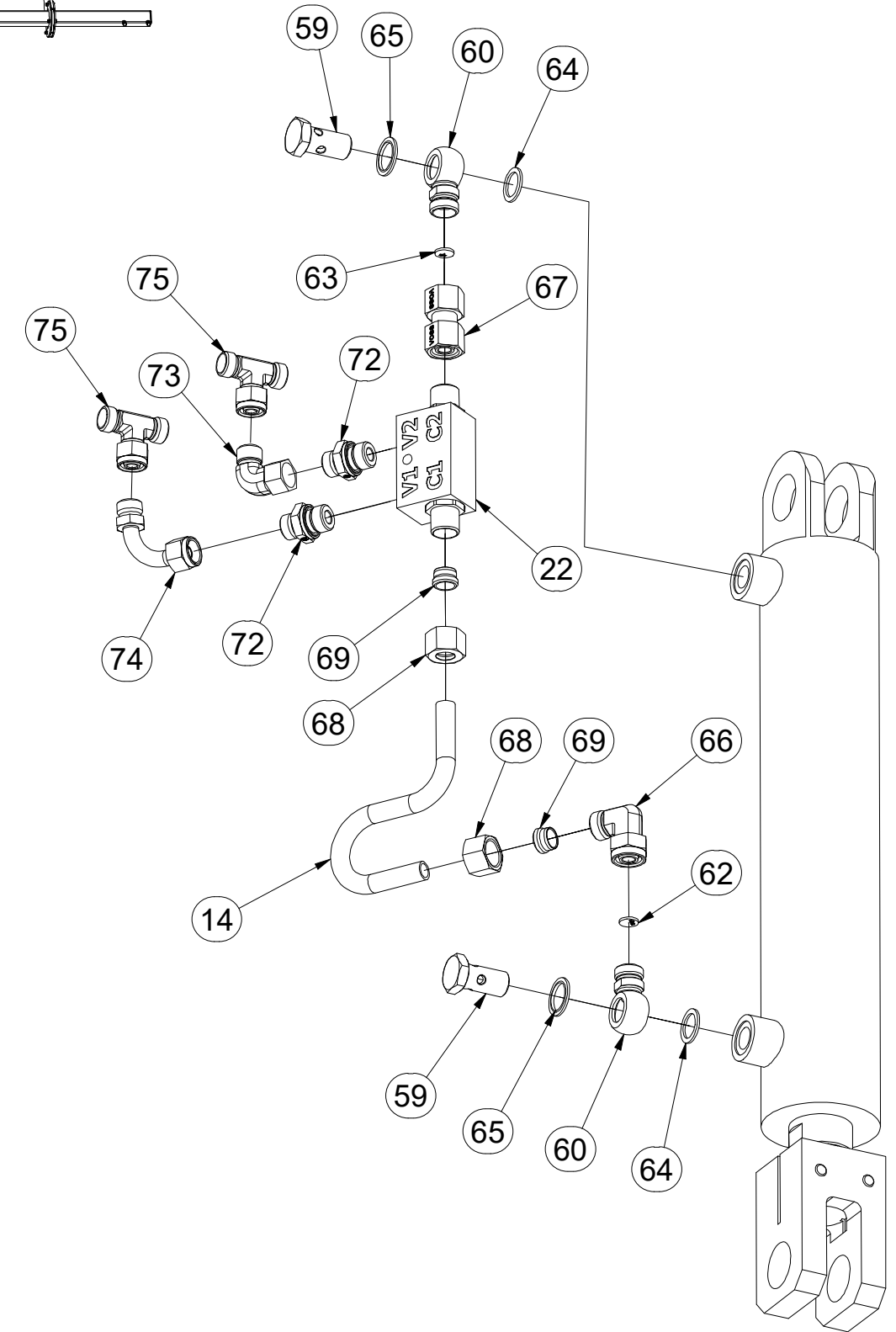

Ⓒ SADA FLEXIBOARDŮ - PŘEDNÍ

Ⓓ FLEXIBOARDSATZ - VORNE

Ⓕ KIT DE FLEXIBOARDS - AVANT

Ⓖ FLEXIBOARD SET - FRONT

Ⓡ КОМПЛЕКТ FLEXIBOARD - ПЕРЕДНИЙ

Ⓢ ZESTAW FLEXIBOARDOW - PRZEDNI



VZ00017878

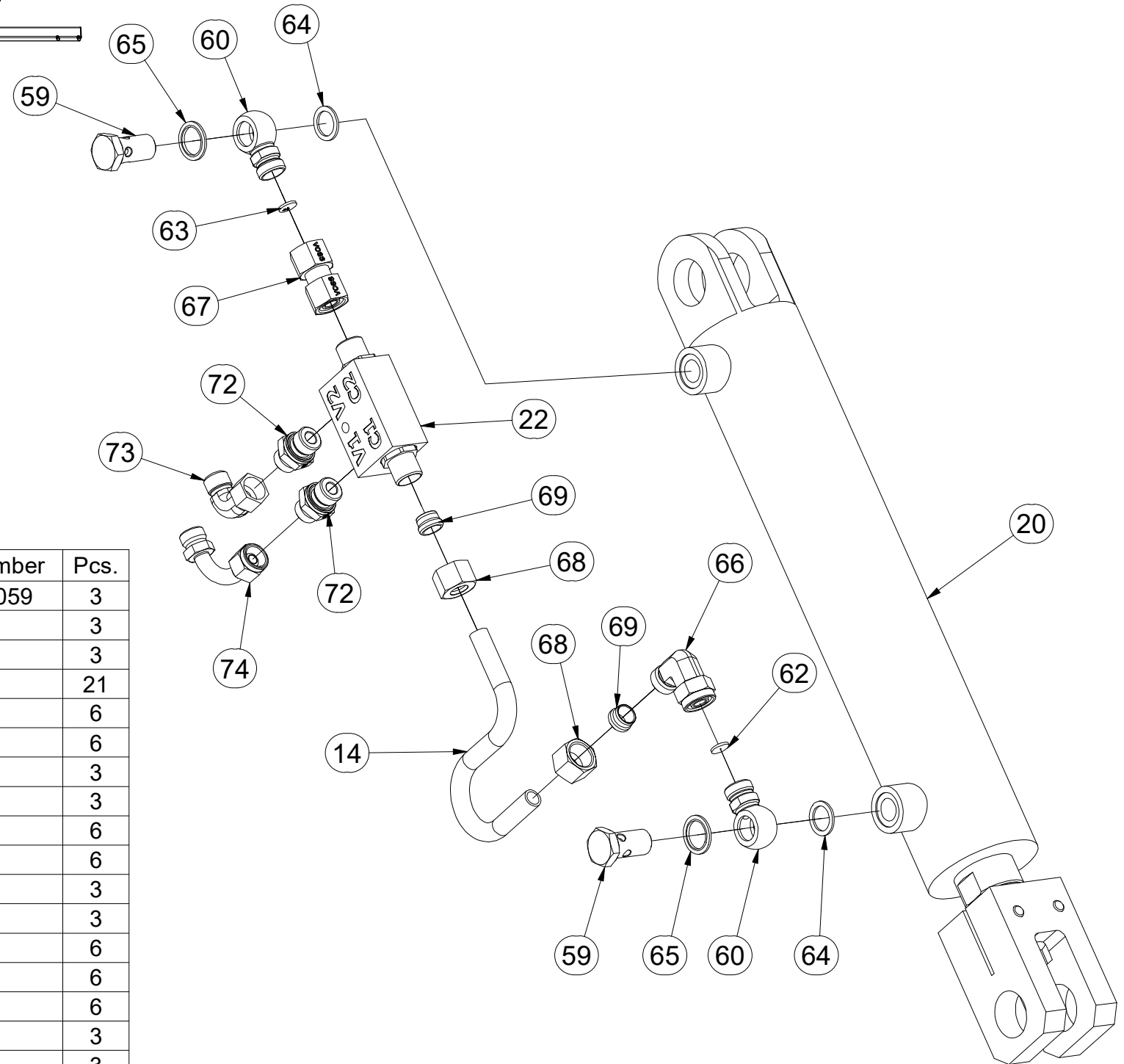
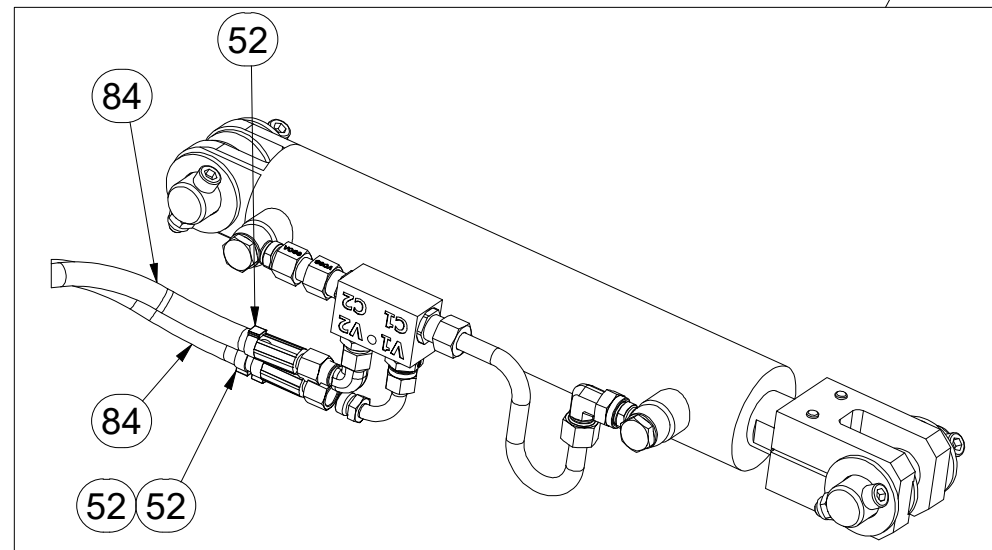
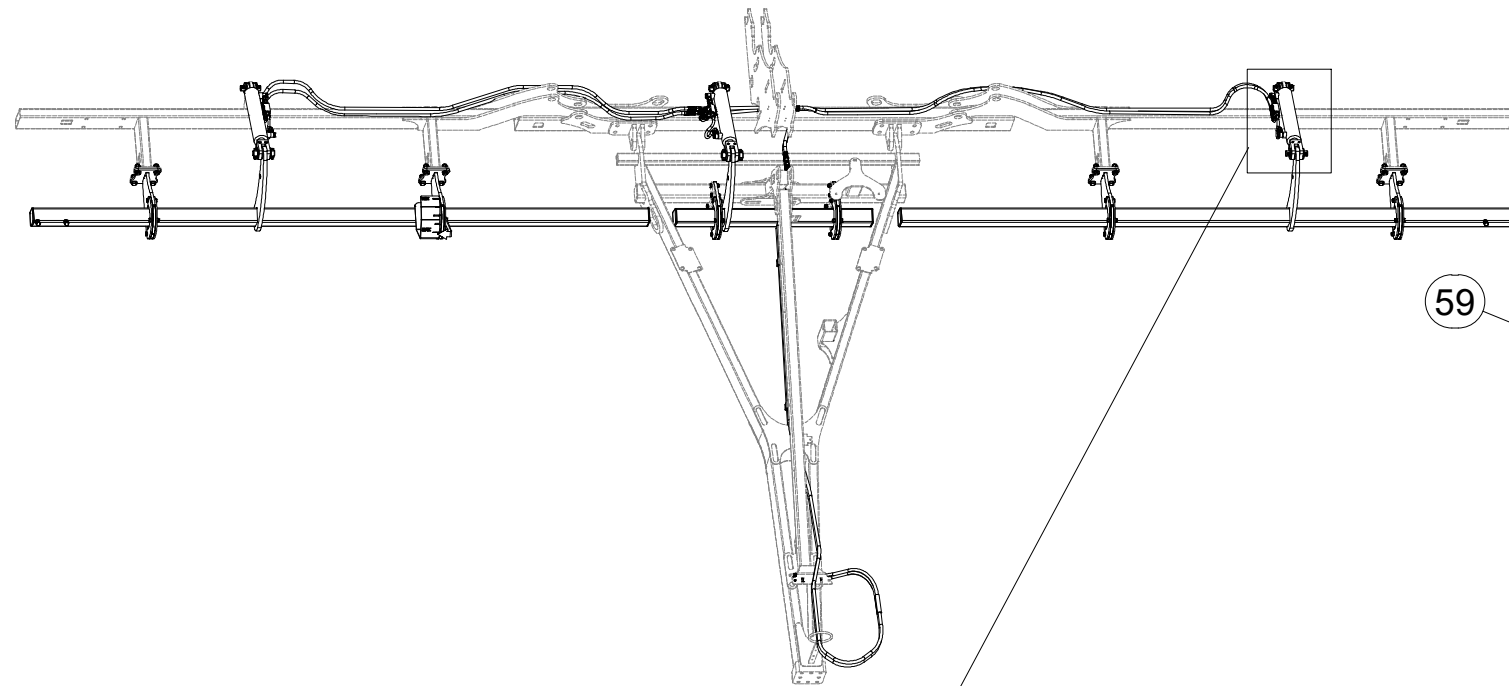

Pos.	Part Number	Pcs.
14	VZ00023059	3
20	m14371	3
22	m08083	3
52	m11253	21
59	m08460	6
60	m08461	6
62	m10649	3
63	m10774	3
64	m04222	6
65	m12442	6
66	m07654	3
67	m22306	3
68	m08861	6
69	m08862	6
72	m06528	6
73	m06803	3
74	m04024	3
84	m08000	2

ⒸZ SADA FLEXIBOARDŮ - PŘEDNÍ

Ⓓ FLEXIBOARDSATZ - VORNE

Ⓕ KIT DE FLEXIBOARDS - AVANT

ⒸB FLEXIBOARD SET - FRONT

ⒸU КОМПЛЕКТ FLEXIBOARD - ПЕРЕДНИЙ

ⒸL ZESTAW FLEXIBOARDOW - PRZEDNI



VZ00017878

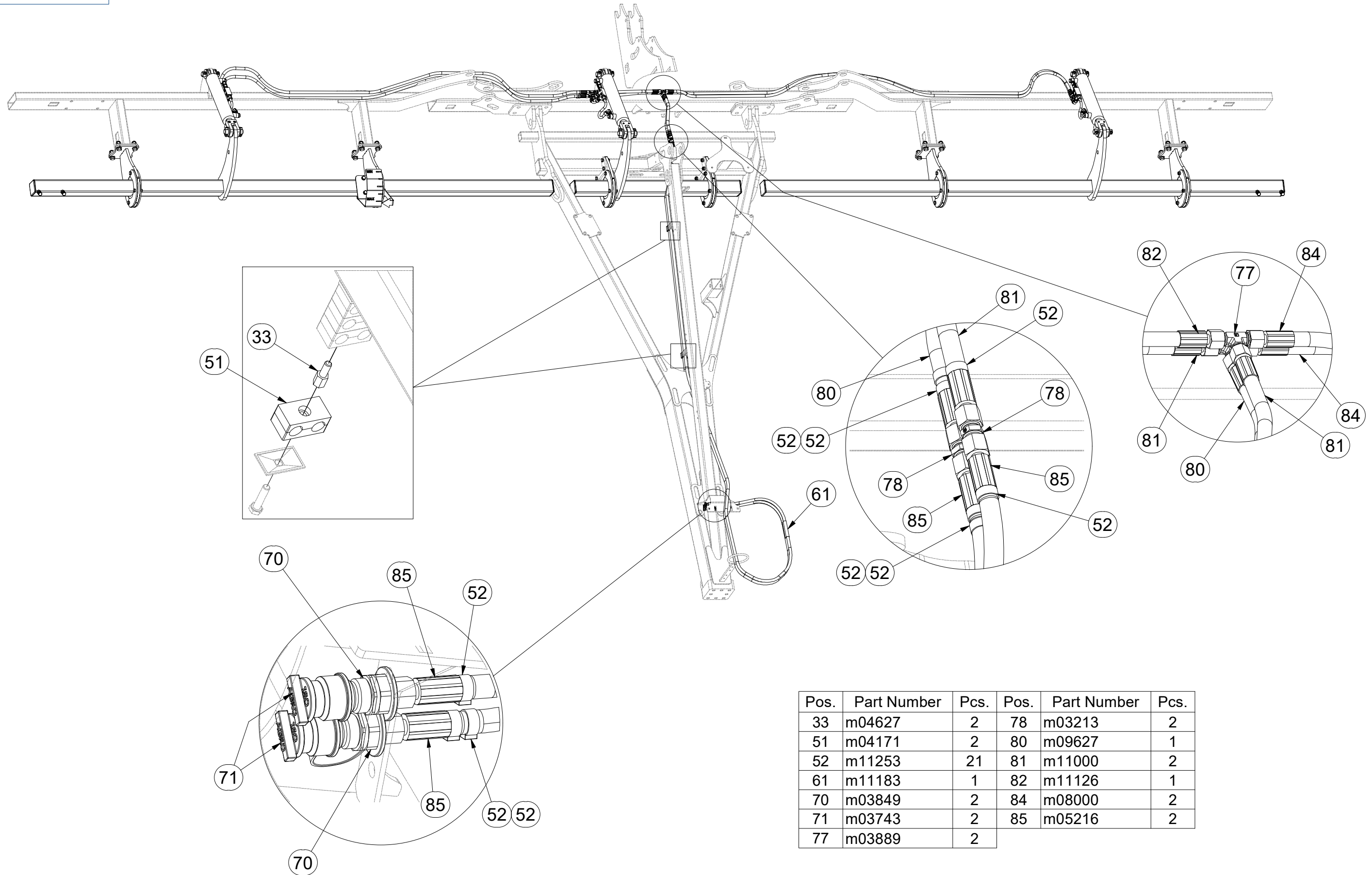

(CZ) FLEXIBOARD - PŘEDNÍ
 (D) FLEXIBOARD - VORDERE
 (F) FLEXIBOARD - AVANT

(GB) FLEXIBOARD - FRONT
 (RU) FLEXIBOARD - ПЕРЕДНИЙ
 (PL) FLEXIBOARD - PRZEDNI



4013079

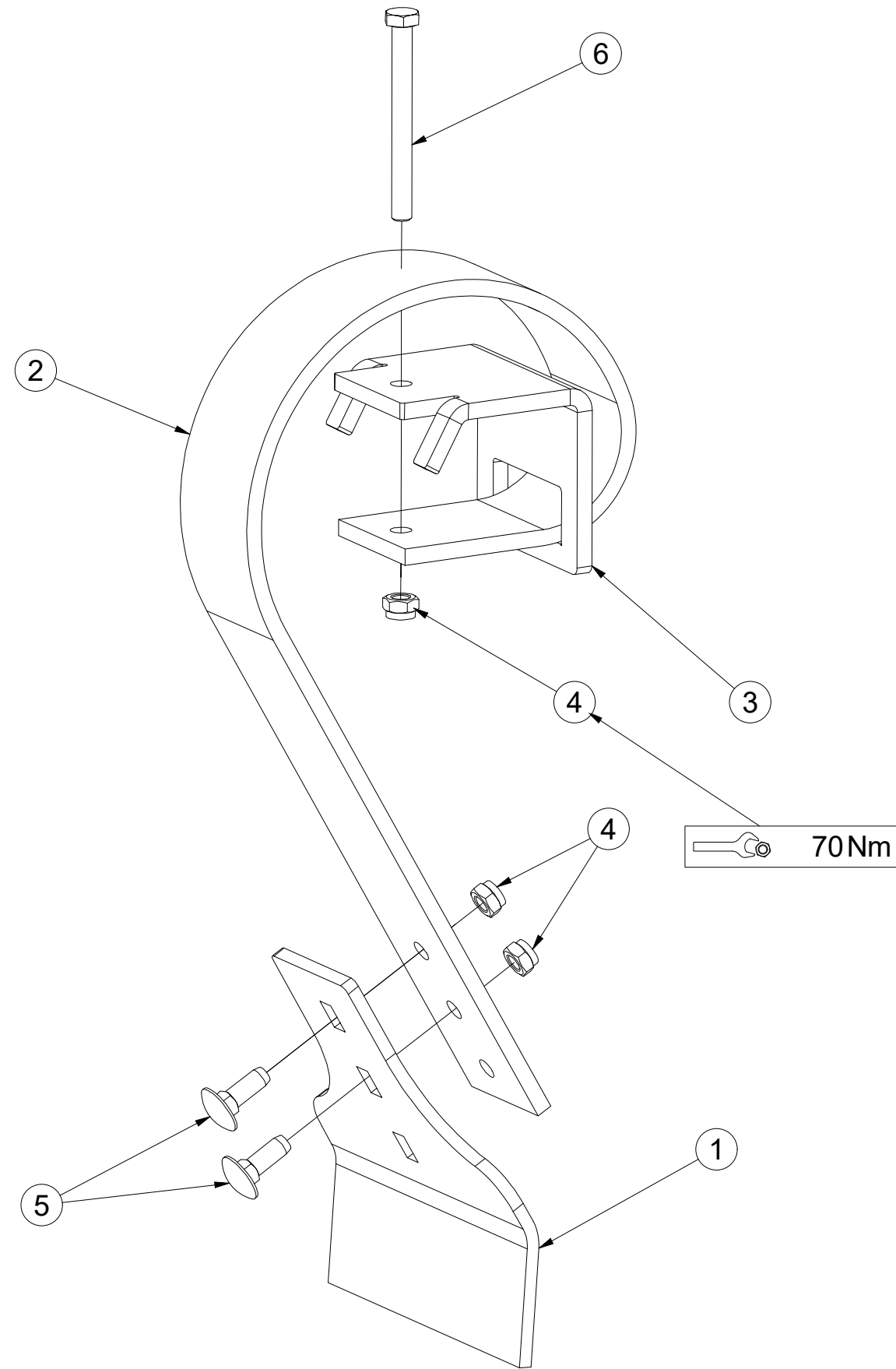
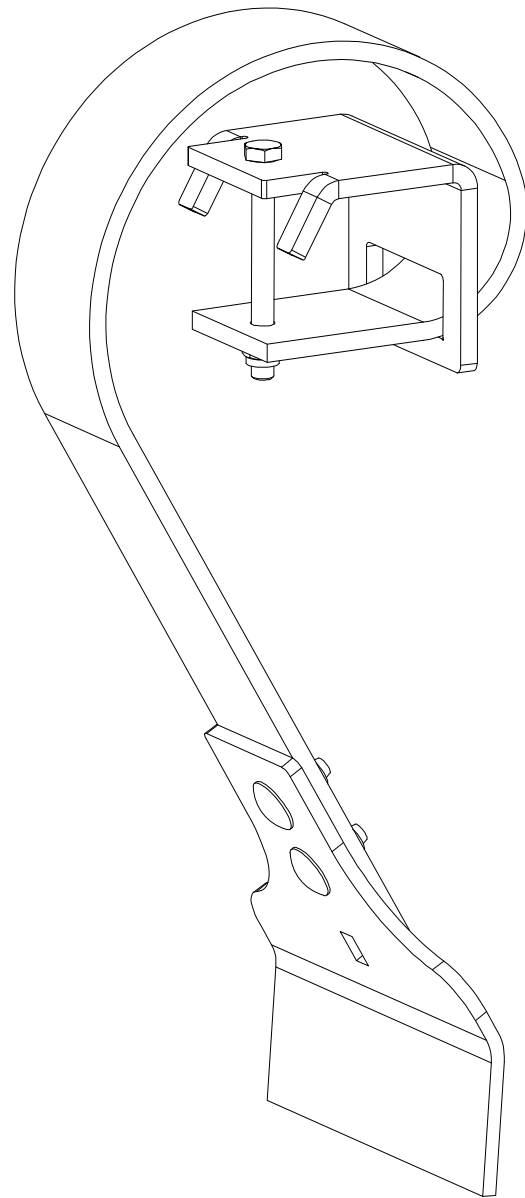

Pos.	Part Number	Pcs.
1	4011709	1
2	9004399	1
3	4023485	1
4	m04301	3
5	m10618	2
6	m13467	1

Ⓒ SEKCE PRACOVNÍ
Ⓓ ARBEITSSEKTION
Ⓕ SECTION DE TRAVAIL

Ⓖ WORKING SECTION
Ⓡ СЕКЦИЯ РАБОЧАЯ
Ⓣ SEKCJA ROBOCZEGO



VZ00012287

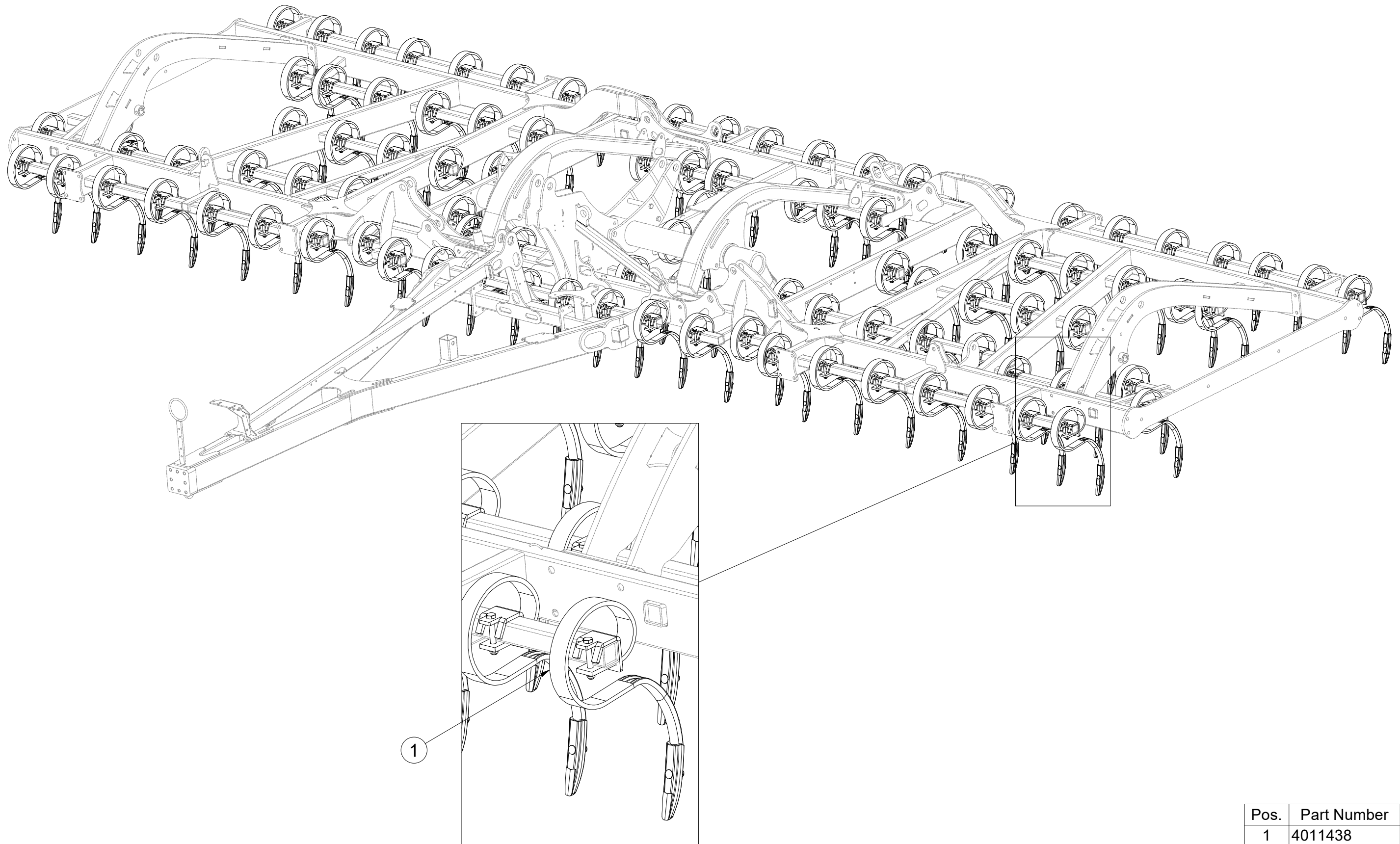

Pos.	Part Number	Pcs.
1	4011438	101

ⒸZ JEDNOTKA PRACOVNÍ DLÁTO

Ⓓ ARBEITSEINHEIT MEISSEL

Ⓕ UNITÉ DE TRAVAIL CISEAU

4011438

ⒸB WORKING CHISEL UNIT

Ⓔ РАБОЧИЙ УЗЕЛ ЧИЗЕЛЬ

Ⓖ JEDNOSTKA ROBOCZA DŁUTO

Farmet

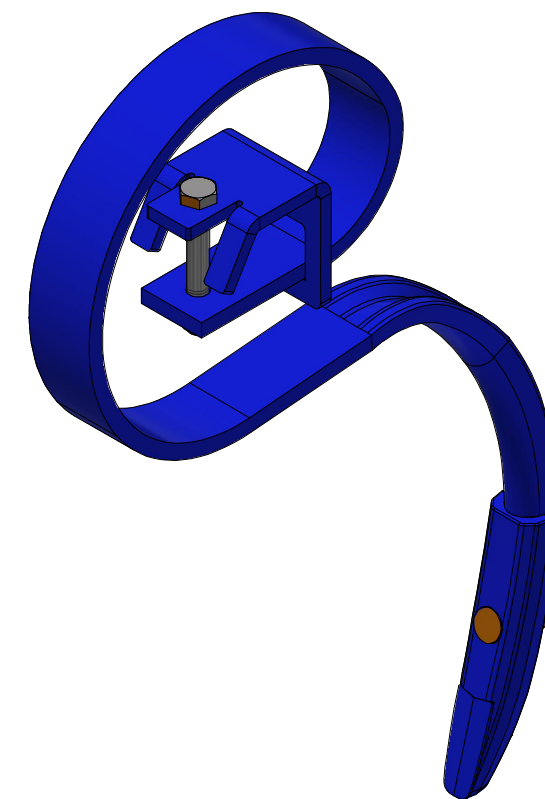
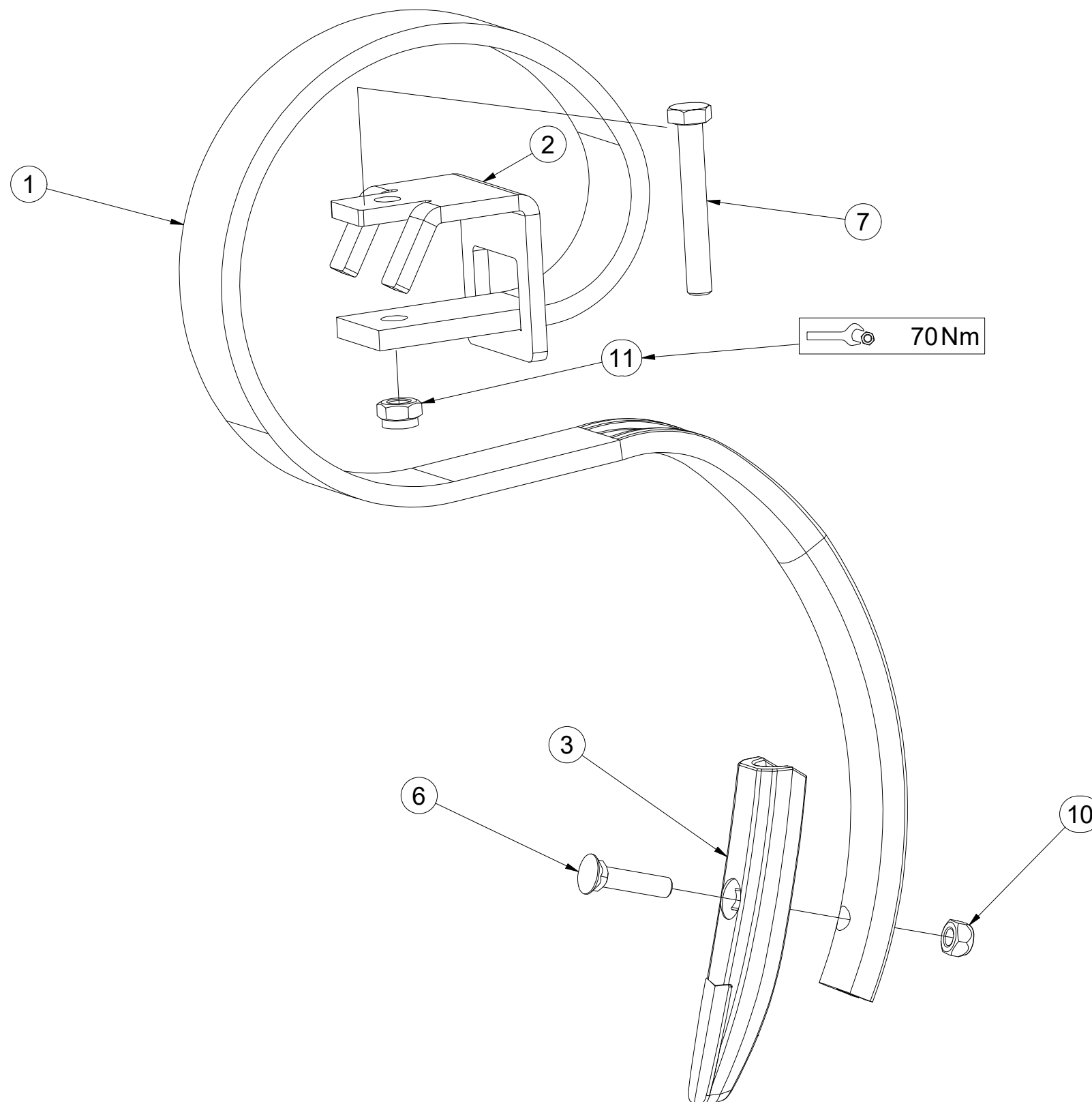

Pos.	Part Number	Pcs.
1	9004270	1
2	4023484	1
3	4011647	1
6	m16625	1
7	m11904	1
10	m11530	1
11	m04301	1

(CZ) SADA FLEXIBOARDŮ – ZADNÍ
 (D) FLEXIBOARDSATZ – HINTEN
 (F) KIT DE FLEXIBOARDS – ARRIÈRE

(GB) FLEXIBOARD SET – REAR
 (RU) КОМПЛЕКТ FLEXIBOARD – ЗАДНИЙ
 (PL) ZESTAW FLEXIBOARDOW – TYLNY



3009019

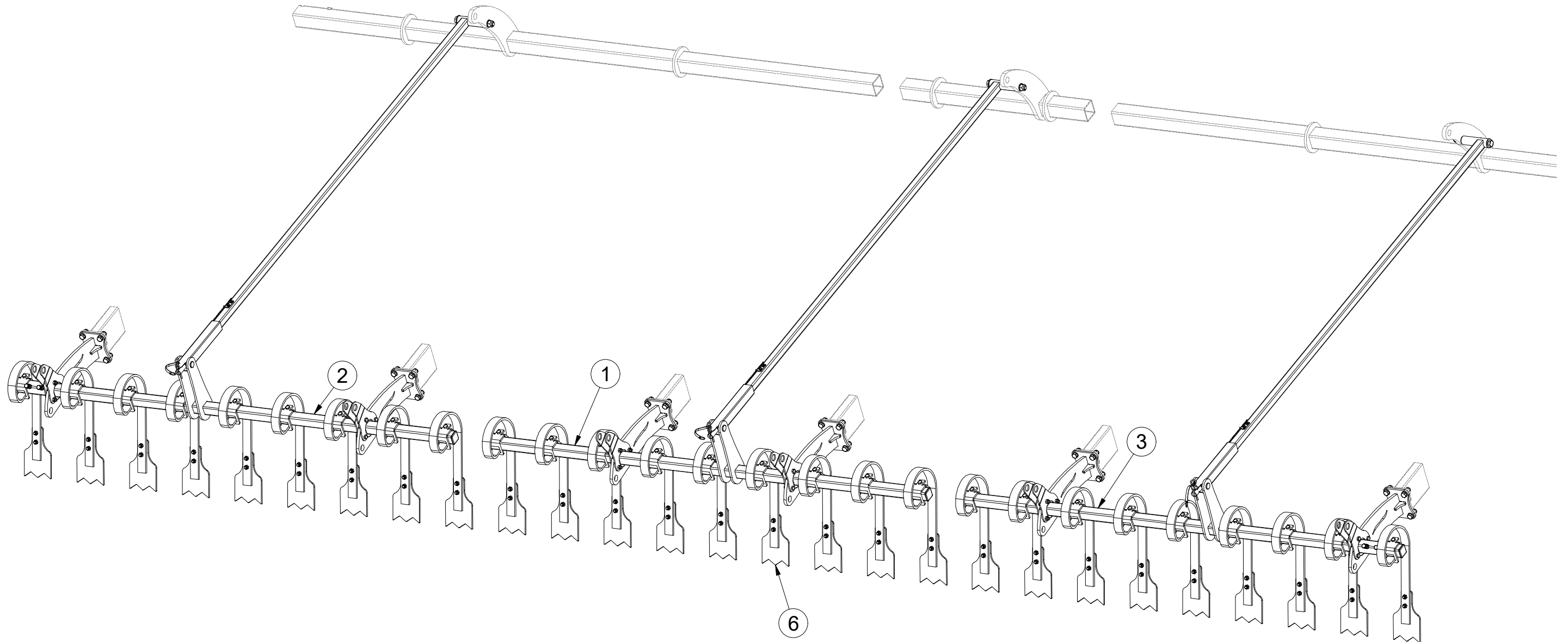

Pos.	Part Number	Pcs.
1	3009022	1
2	3009023	1
3	3009024	1
6	4011420	27

☉ SADA FLEXIBOARDŮ – ZADNÍ

☉ FLEXIBOARDSATZ – HINTEN

☉ KIT DE FLEXIBOARDS – ARRIÈRE

☉ FLEXIBOARD SET – REAR

☉ КОМПЛЕКТ FLEXIBOARD – ЗАДНИЙ

☉ ZESTAW FLEXIBOARDOW – TYLNY



3009019

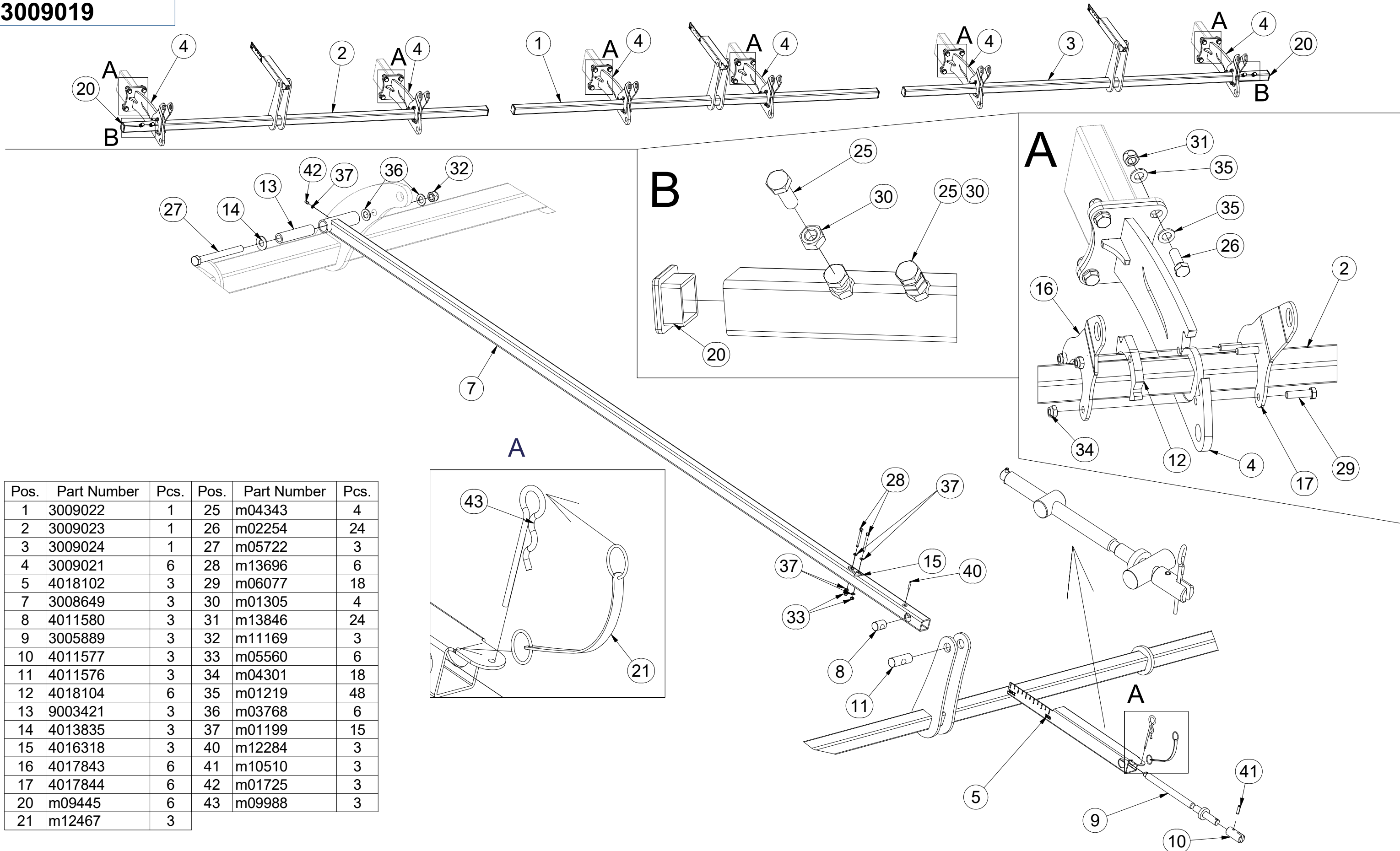

Pos.	Part Number	Pcs.	Pos.	Part Number	Pcs.
1	3009022	1	25	m04343	4
2	3009023	1	26	m02254	24
3	3009024	1	27	m05722	3
4	3009021	6	28	m13696	6
5	4018102	3	29	m06077	18
7	3008649	3	30	m01305	4
8	4011580	3	31	m13846	24
9	3005889	3	32	m11169	3
10	4011577	3	33	m05560	6
11	4011576	3	34	m04301	18
12	4018104	6	35	m01219	48
13	9003421	3	36	m03768	6
14	4013835	3	37	m01199	15
15	4016318	3	40	m12284	3
16	4017843	6	41	m10510	3
17	4017844	6	42	m01725	3
20	m09445	6	43	m09988	3
21	m12467	3			

- Ⓒ FLEXIBOARD - ZADNÍ
- Ⓓ FLEXIBOARD - HINTERE
- Ⓕ FLEXIBOARD - ARRIÈRE

- Ⓒ FLEXIBOARD - REAR
- Ⓓ FLEXIBOARD - ЗАДНИЙ
- Ⓕ FLEXIBOARD - TYLNY



4011420

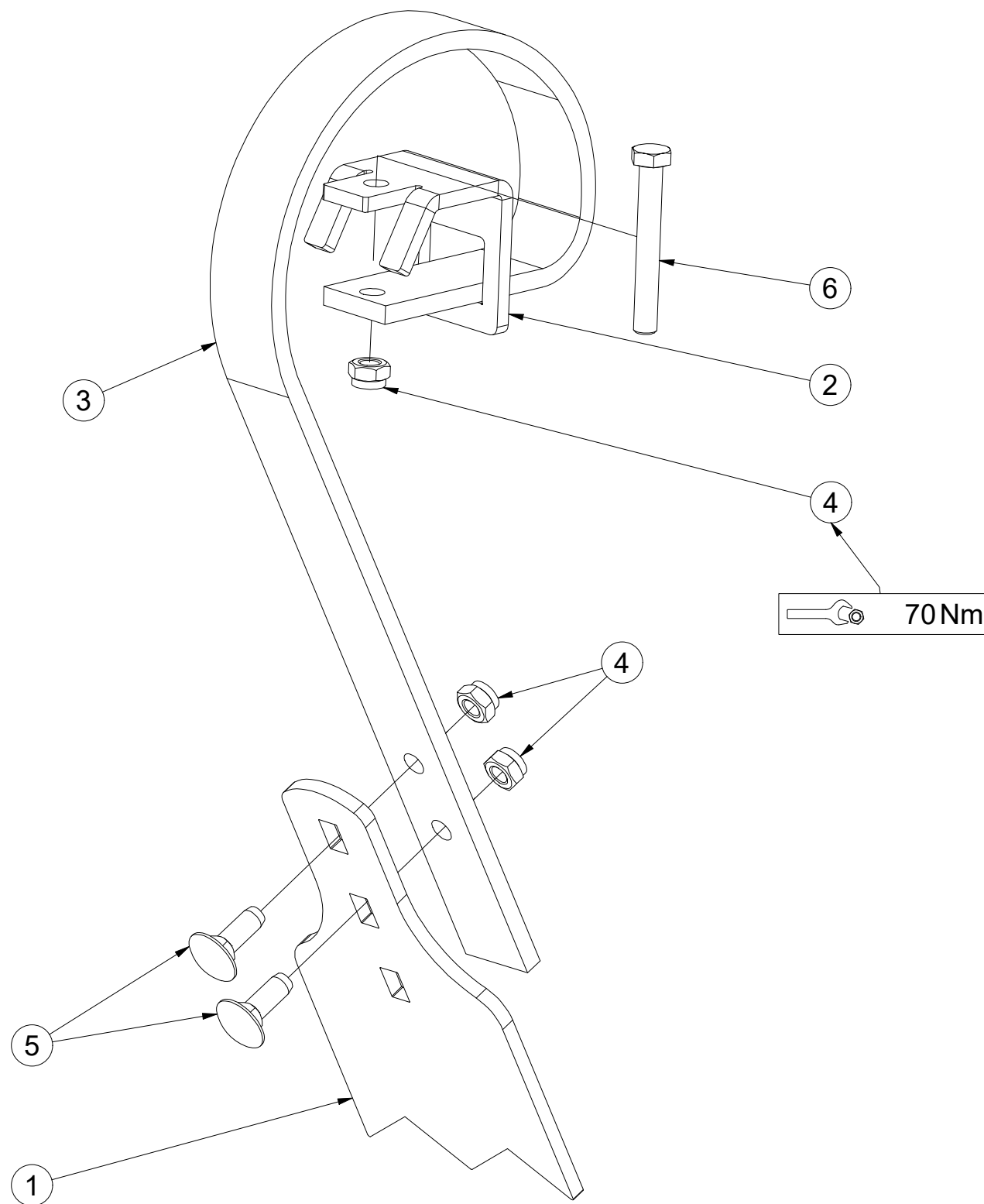

Pos.	Part Number	Pcs.
1	4011681	1
2	4023484	1
3	9003374	1
4	m04301	3
5	m10618	2
6	m13468	1

CZ SADA ZAVLAČOVÁNÍ
 D STRIEGELZINKENSATZ
 F KIT DE HERSAGE

GB LEVELLING SET
 RU КОМПЛЕКТ ЗАДЕЛЫВАНИЯ
 PL ZESTAW ZAGARNIANICZY



3009020

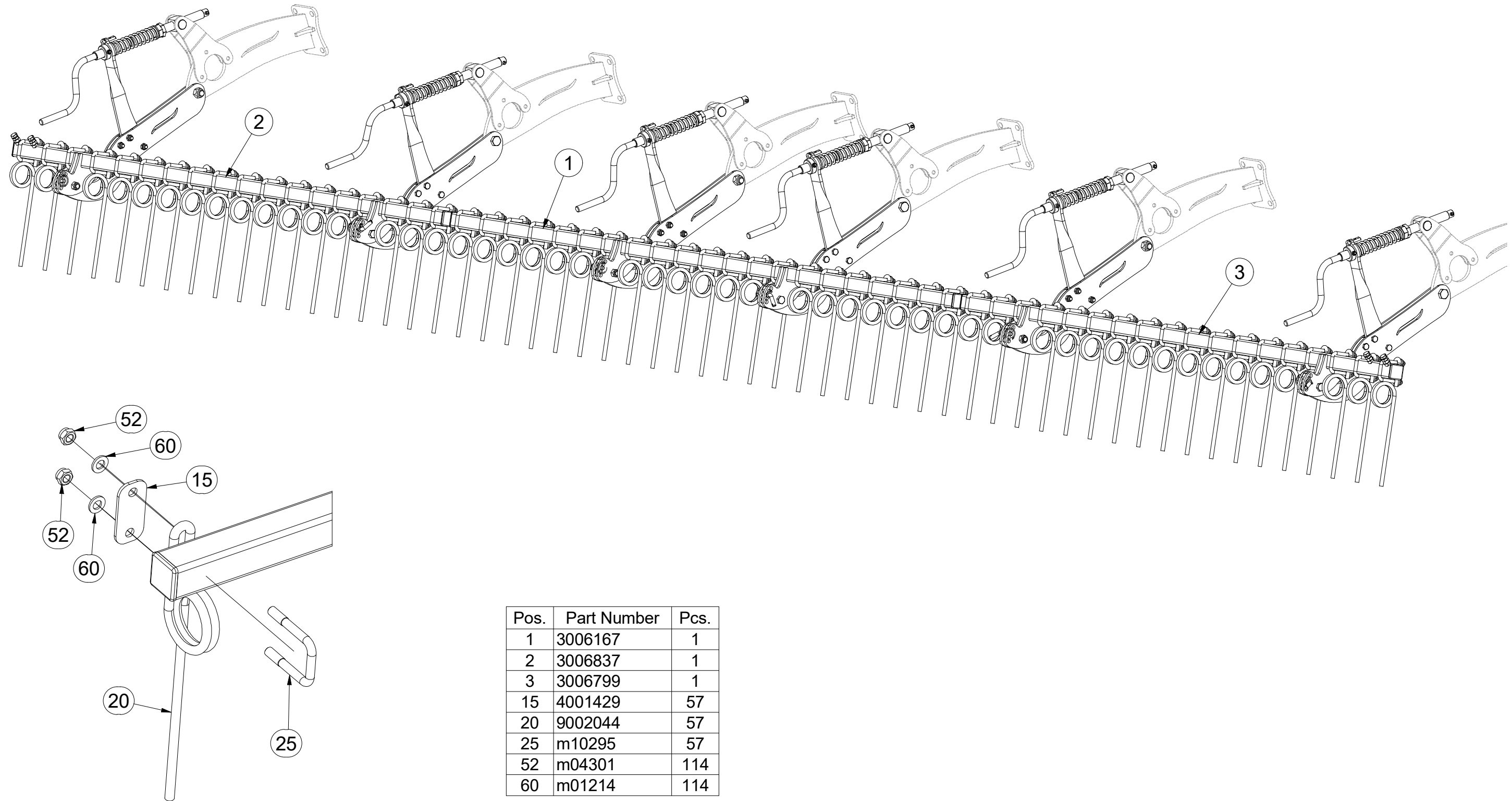

Pos.	Part Number	Pcs.
1	3006167	1
2	3006837	1
3	3006799	1
15	4001429	57
20	9002044	57
25	m10295	57
52	m04301	114
60	m01214	114

CZ SADA ZAVLAČOVÁNÍ
 D STRIEGELZINKENSATZ
 F KIT DE HERSAGE

GB LEVELLING SET
 RU КОМПЛЕКТ ЗАДЕЛЫВАНИЯ
 PL ZESTAW ZAGARNIANICZY



3009020

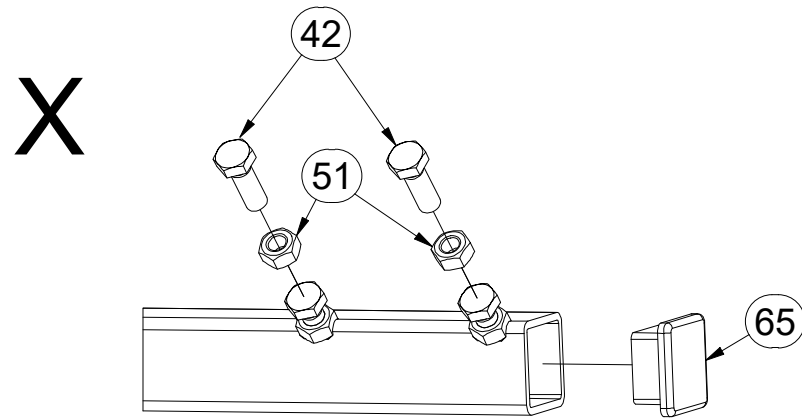
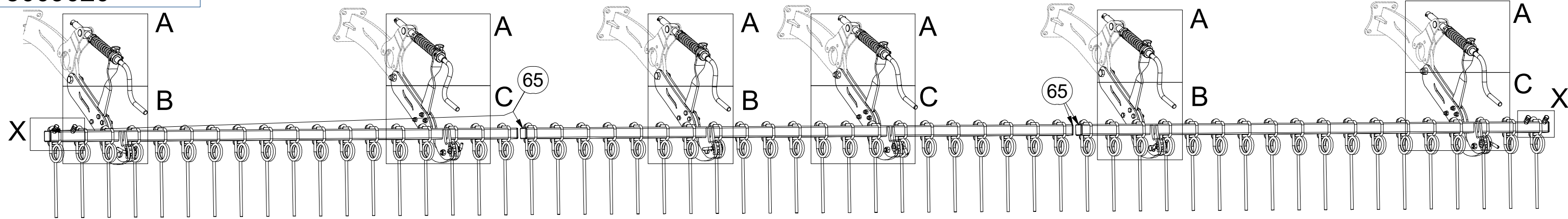

Pos.	Part Number	Pcs.	Pos.	Part Number	Pcs.	Pos.	Part Number	Pcs.
4	4012203	6	17	4011904	6	43	m12130	24
5	4012183	12	18	4011870	6	44	m10112	6
6	4021490	6	19	4011898	6	45	m14496	6
7	4021489	6	26	m09141	6	50	m04503	6
8	3006007	6	27	m13626	6	51	m01305	4
9	4011897	6	30	4016279	6	55	m11169	6
10	4011891	6	31	m10736	6	65	m09445	6
11	4011890	6	32	m10454	6	66	m02505	6
14	4011889	6	40	m13471	6	54	m13846	6
16	4012158	12	42	m04343	4	53	m21001	24

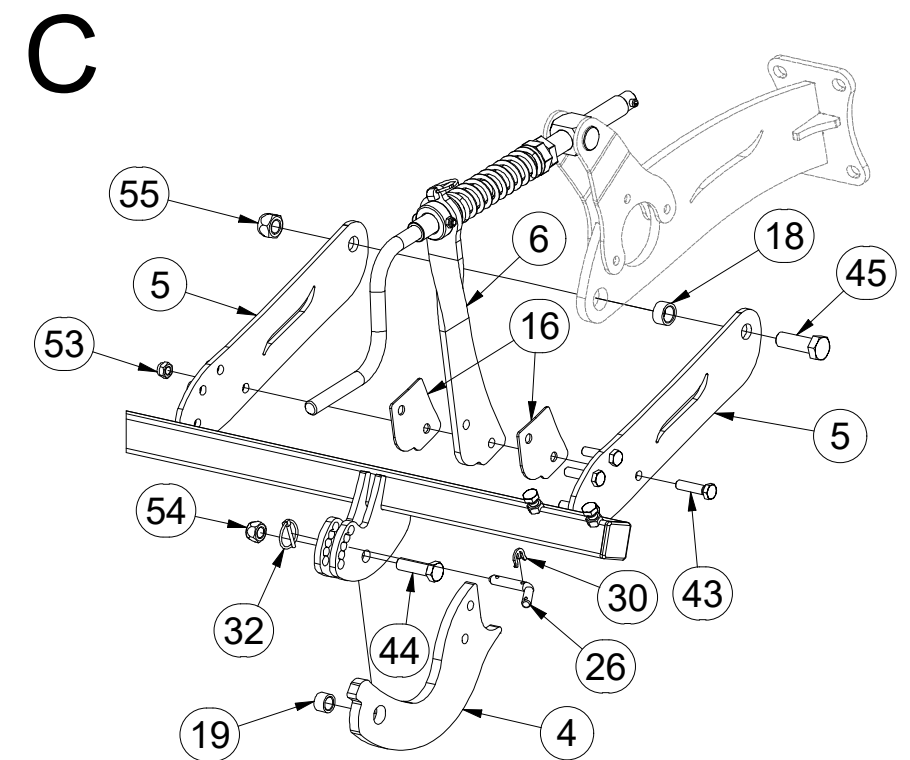
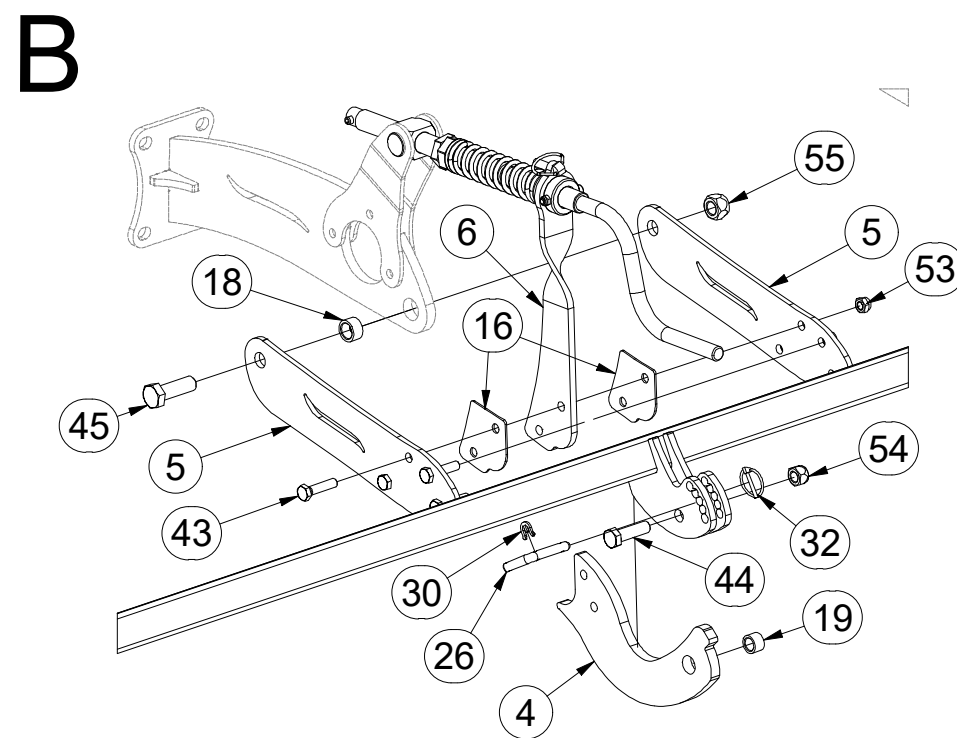
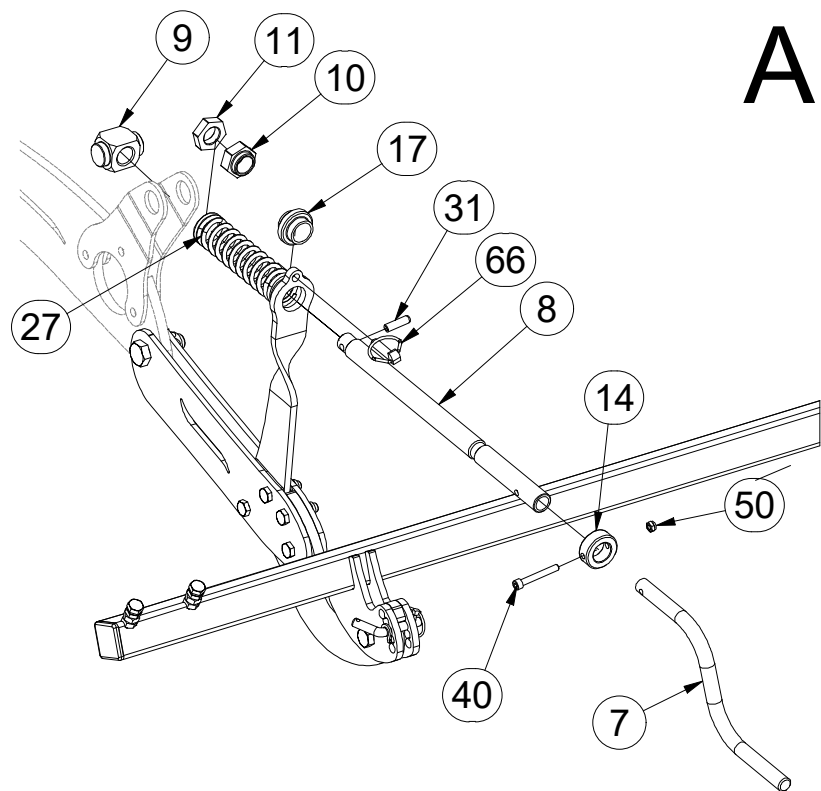

CZ TERČE
 D SCHEIBE
 F CIBLES

GB DISCS
 RU ЩИТКИ
 PL TARCZE



VZ00012312

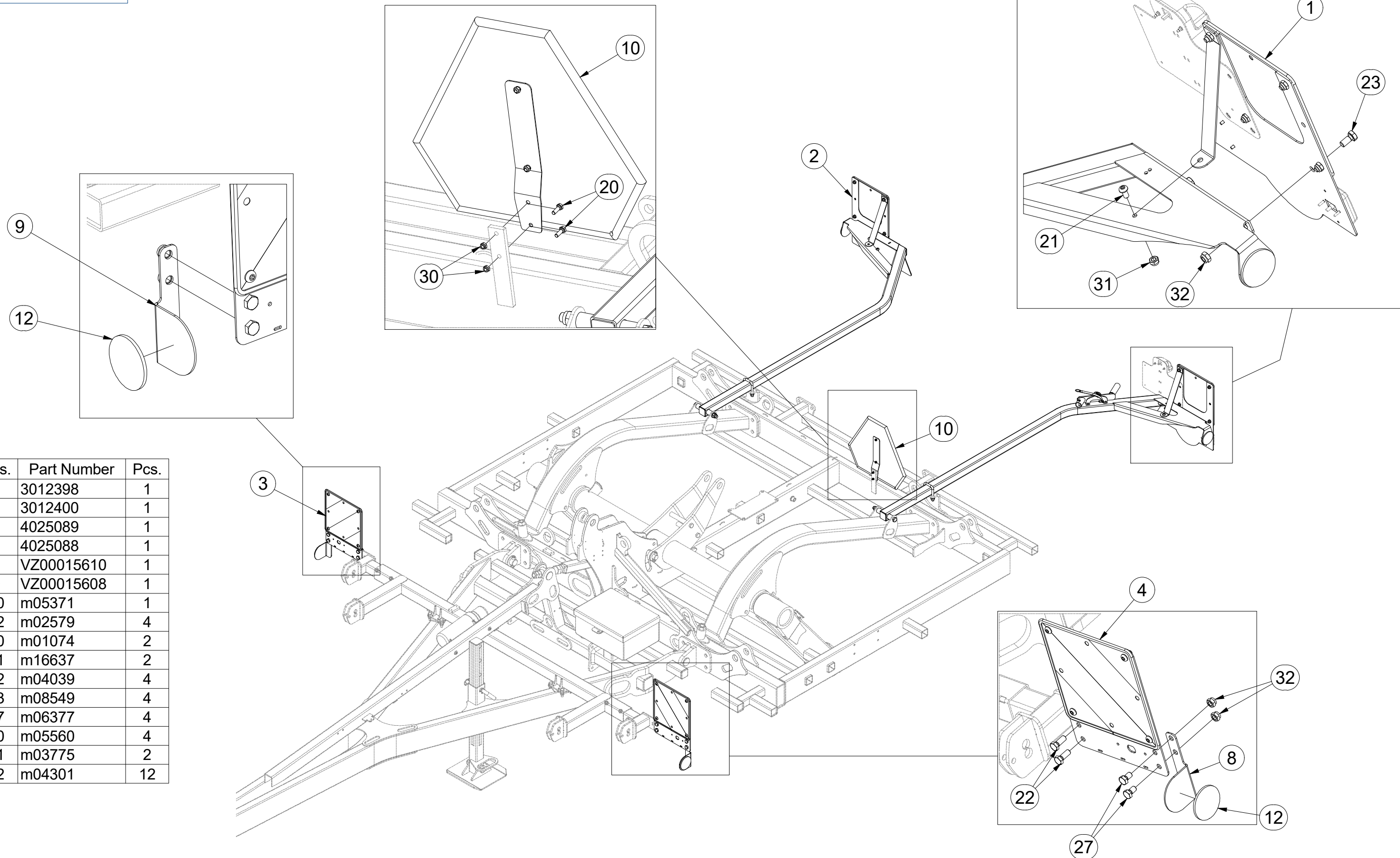

Pos.	Part Number	Pcs.
1	3012398	1
2	3012400	1
3	4025089	1
4	4025088	1
8	VZ00015610	1
9	VZ00015608	1
10	m05371	1
12	m02579	4
20	m01074	2
21	m16637	2
22	m04039	4
23	m08549	4
27	m06377	4
30	m05560	4
31	m03775	2
32	m04301	12

- ⒸZ TERČE
- Ⓓ SCHEIBE
- Ⓕ CIBLES

- ⒼB DISCS
- ⒺU ЩИТКИ
- ⒼL TARCZE



VZ00012312

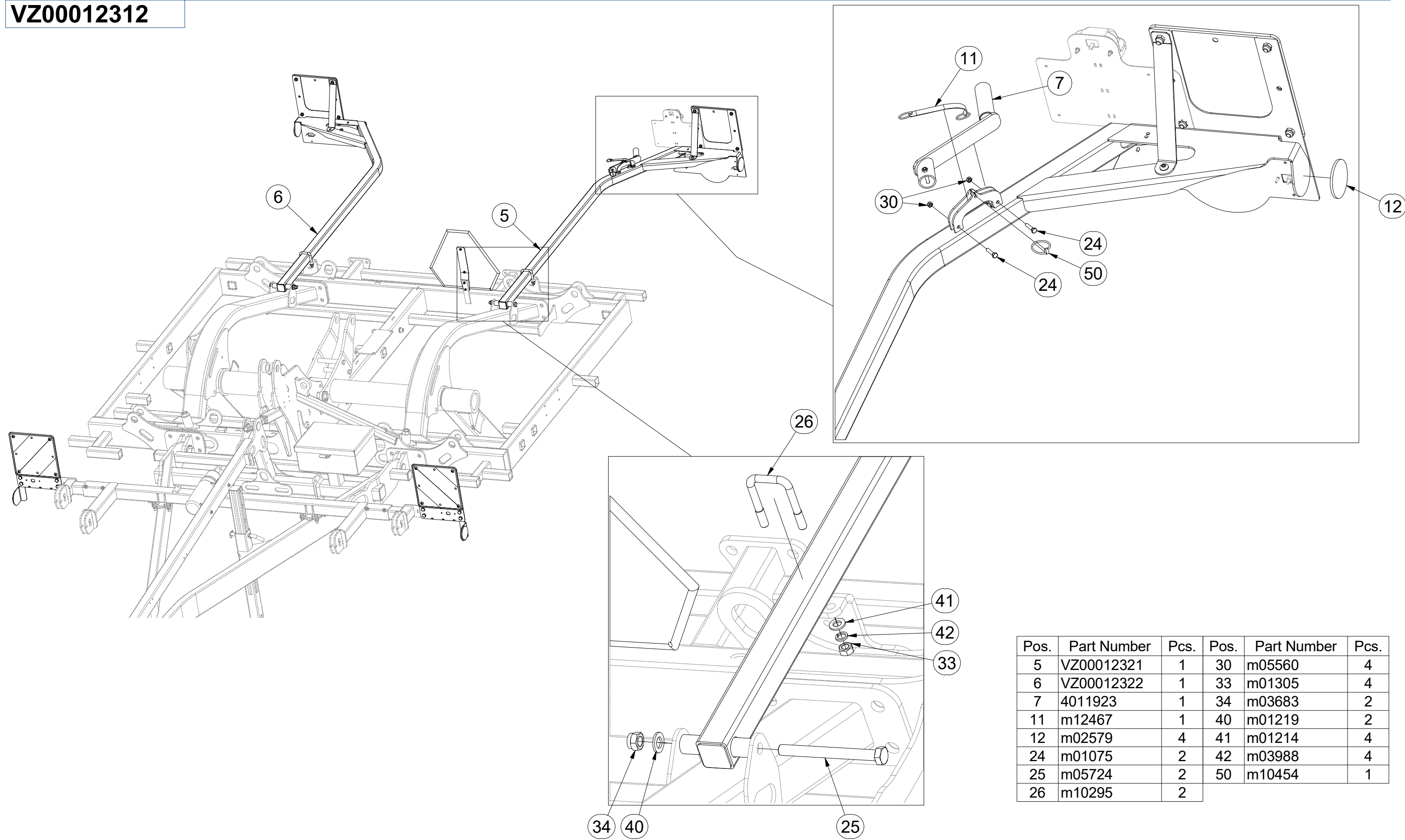

Pos.	Part Number	Pcs.	Pos.	Part Number	Pcs.
5	VZ00012321	1	30	m05560	4
6	VZ00012322	1	33	m01305	4
7	4011923	1	34	m03683	2
11	m12467	1	40	m01219	2
12	m02579	4	41	m01214	4
24	m01075	2	42	m03988	4
25	m05724	2	50	m10454	1
26	m10295	2			

Ⓒ KLIKA
Ⓓ KURBEL
Ⓕ MANIVELLE

Ⓖ HANDLE
Ⓡ РУКОЯТКА
Ⓢ KORBA



4011923

Pos.	Part Number	Pcs.
1	4001533	1
2	4004828	1
3	4011924	1
10	m01295	1
11	m04641	1
12	m06561	1

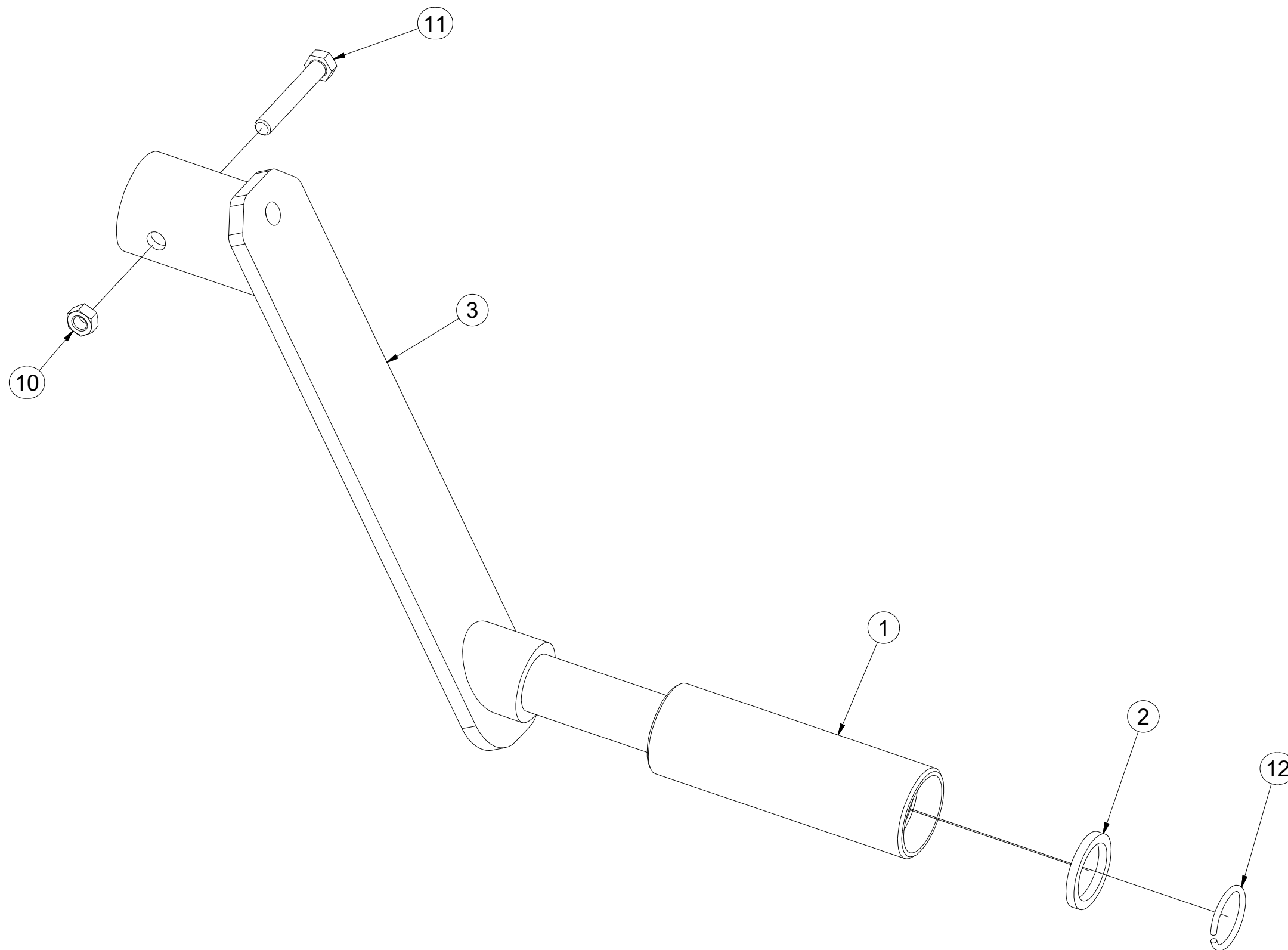

(CZ) SADA HOMOLOGACE
 (D) HOMOLOGATIONSATZ
 (F) KIT DE HOMOLOGATION

(GB) SET OF HOMOLOGATION
 (RU) КОМПЛЕКТ УТВЕРЖДЕНИЯ
 (PL) ZESTAW HOMOLOGACJA



VZ00020241

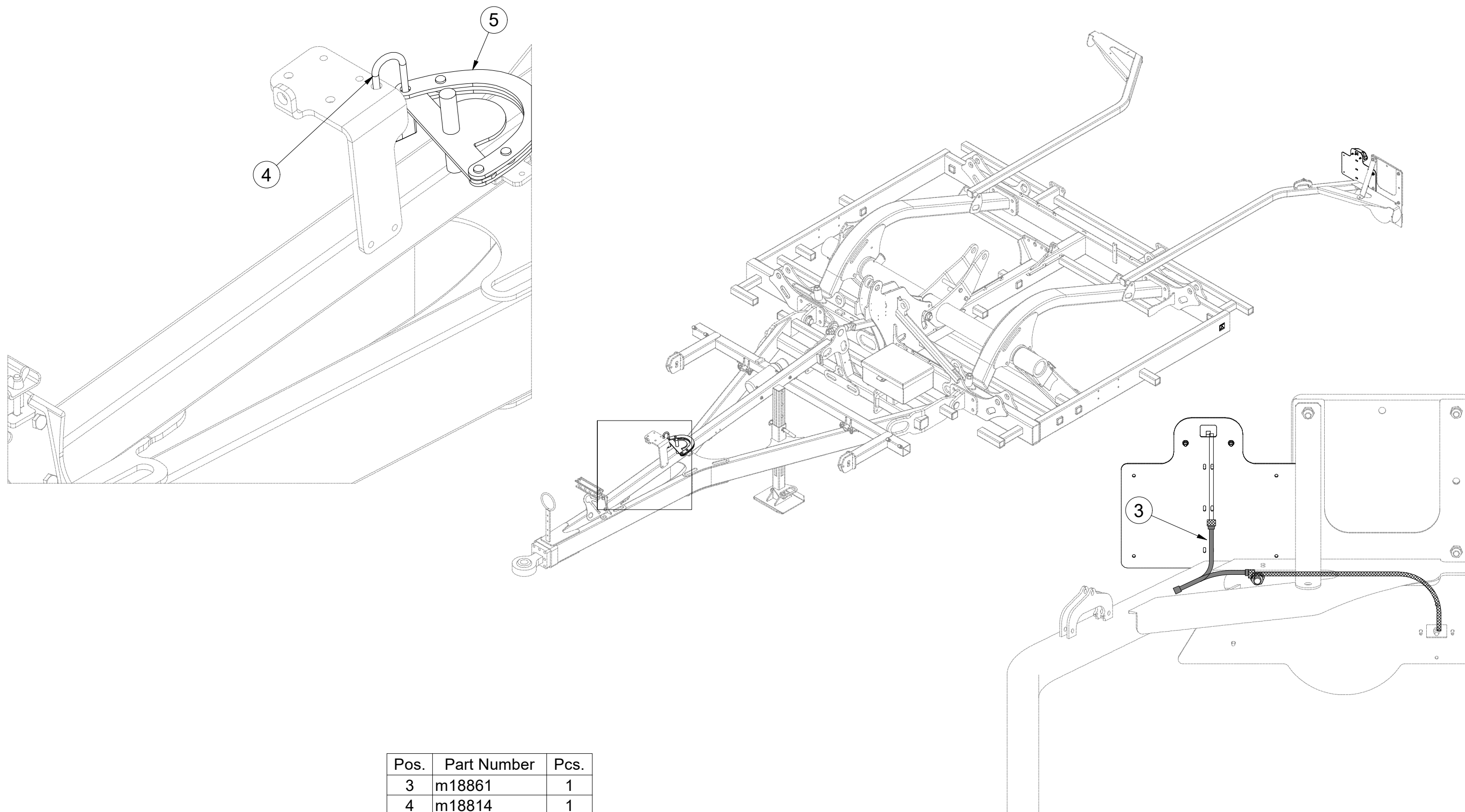

Pos.	Part Number	Pcs.
3	m18861	1
4	m18814	1
5	m19084	1

CZ SADA HOMOLOGACE
 D HOMOLOGATIONSATZ
 F KIT DE HOMOLOGATION

GB SET OF HOMOLOGATION
 RU КОМПЛЕКТ УТВЕРЖДЕНИЯ
 PL ZESTAW HOMOLOGACJA



VZ00020241

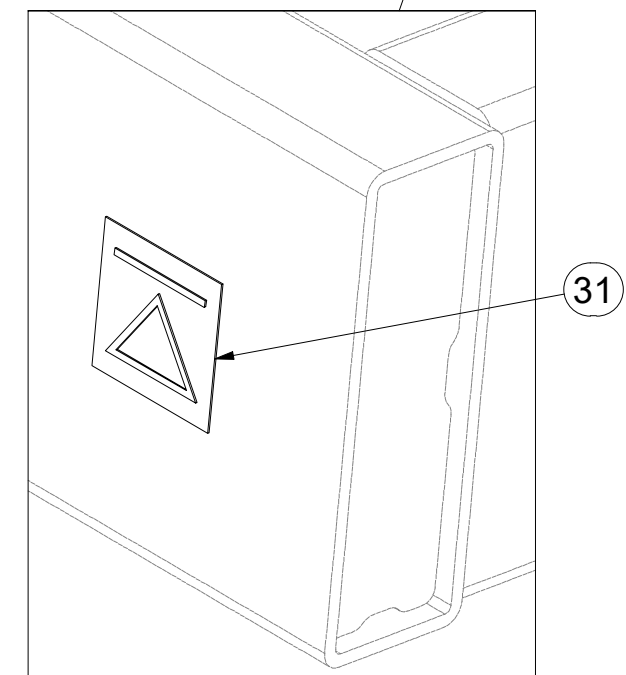
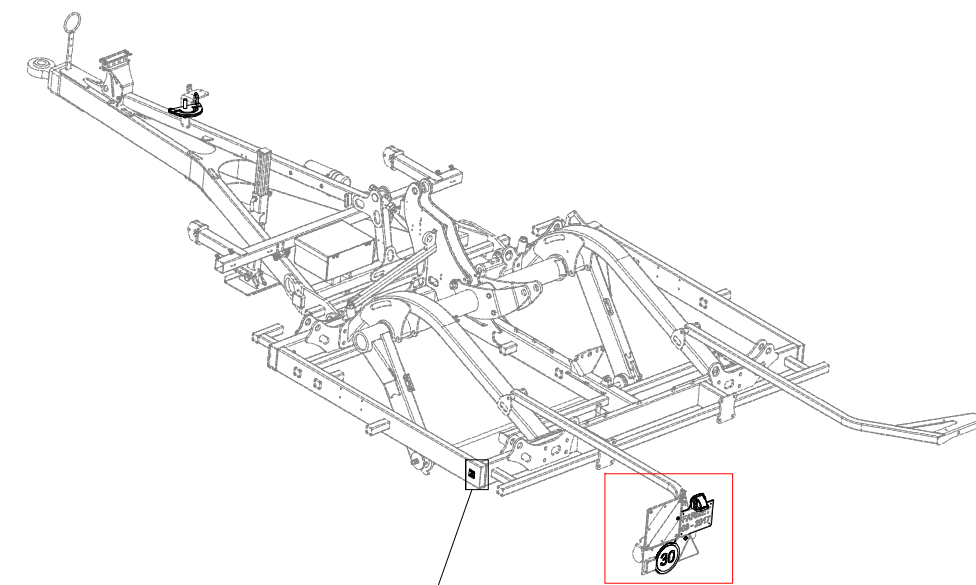
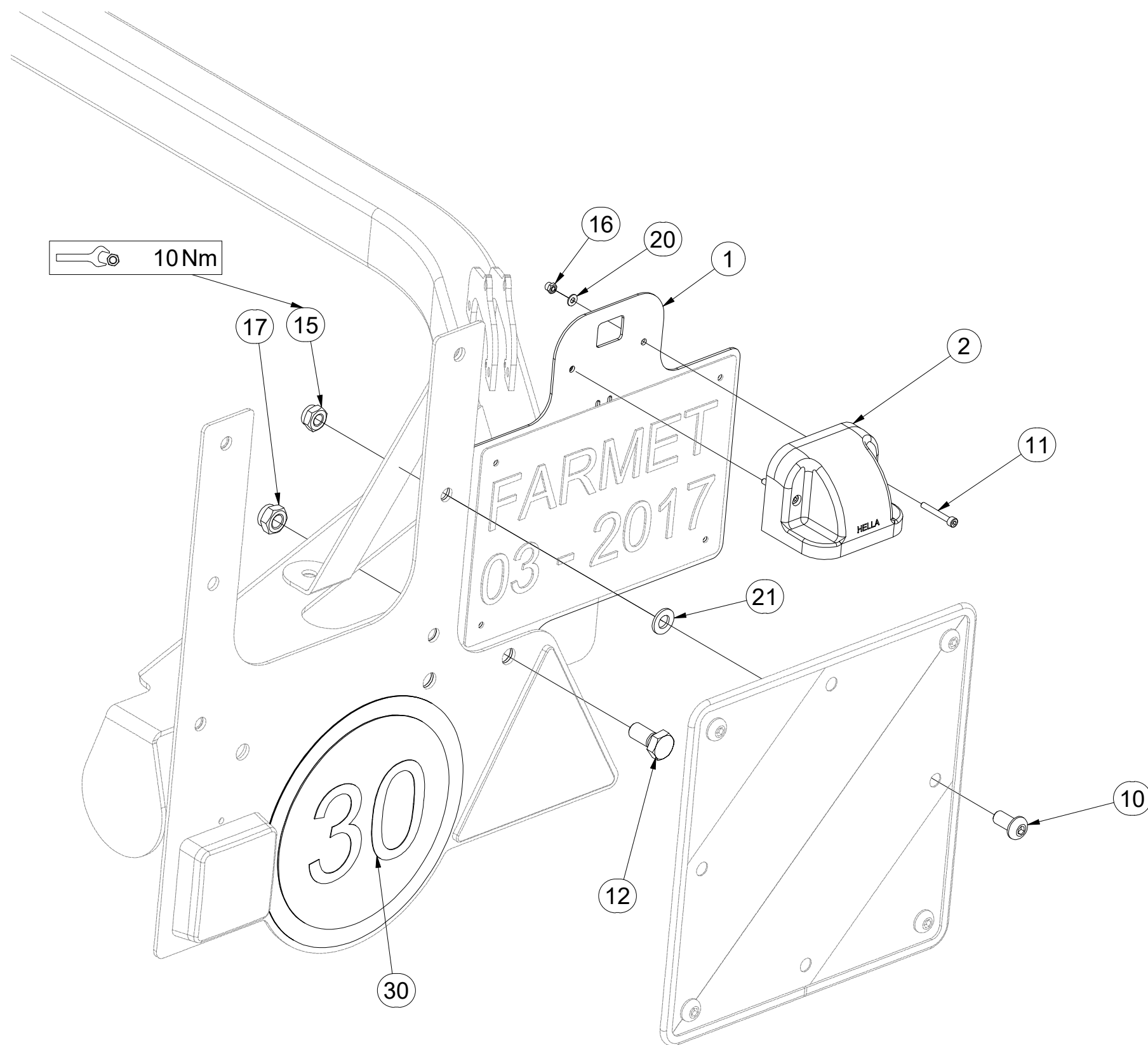

Pos.	Part Number	Pcs.	Pos.	Part Number	Pcs.
1	4026442	1	16	m05562	2
2	m18862	1	17	m04301	1
10	m16637	1	20	m05597	2
11	m16861	2	21	m01209	1
12	m08549	1	30	m19161	1
15	m03775	1	31	m03512	2

CZ TERČ PŘEDNÍ LEVÝ
 D SCHILD, VORDERES, LINKES
 F CIBLE AVANT GAUCHE

GB LEFT FRONT DISC
 RU ЩИТОК ПЕРЕДНИЙ ЛЕВЫЙ
 PL TARCZA PRZEDNIA LEWA



4025088

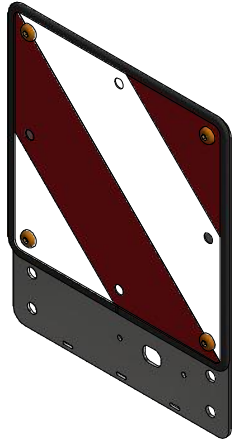
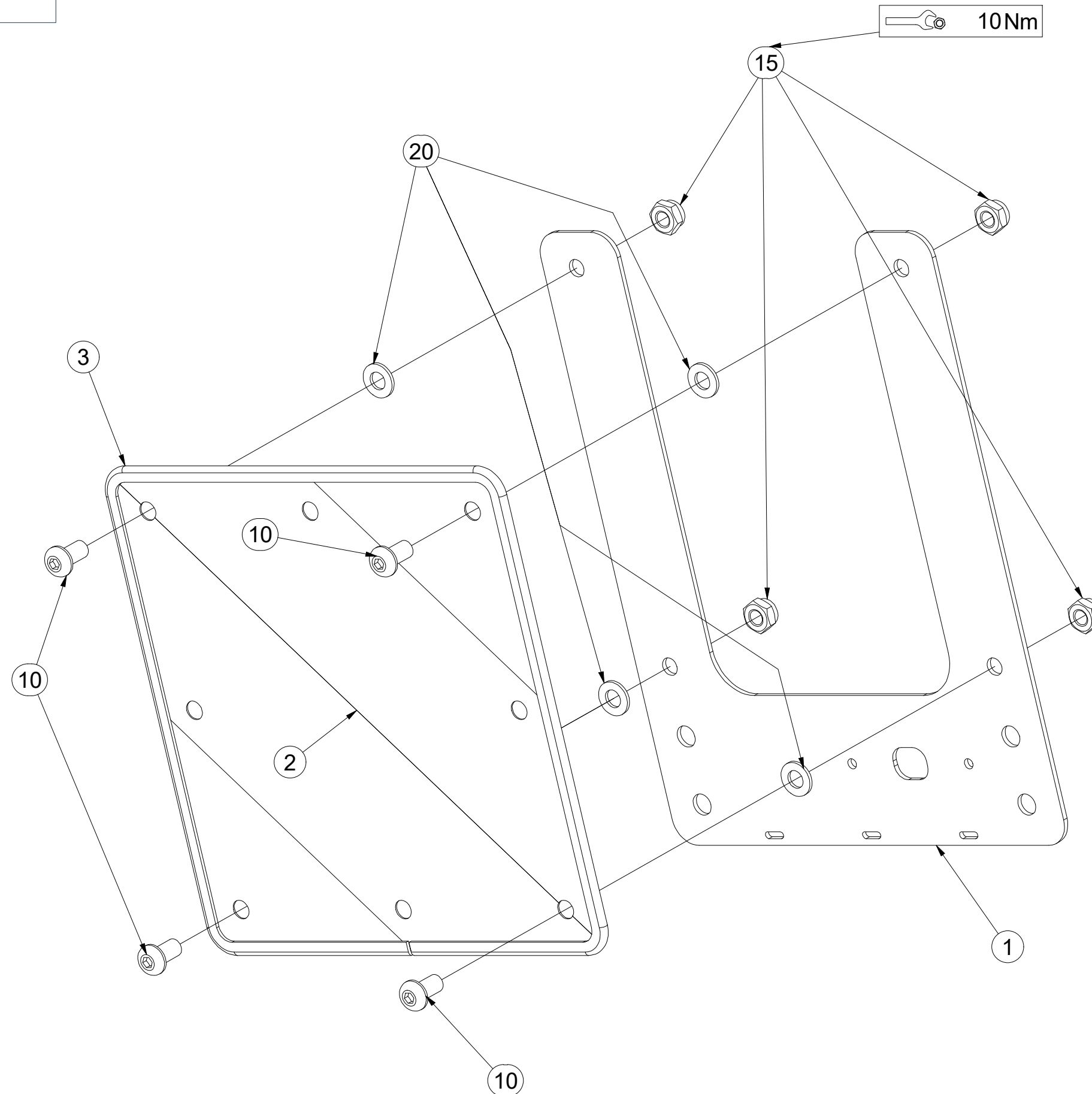

Pos.	Part Number	Pcs.
1	4025090	1
2	m18855	1
3	9005707	1
10	m16637	4
15	m03775	4
20	m01209	4

ⒸZ TERČ PŘEDNÍ PRAVÝ

Ⓓ SCHILD, VORDERES, RECHTES

Ⓕ CIBLE AVANT DROITE

ⒼB RIGHT FRONT DISC

ⒶU ЩИТОК ПЕРЕДНИЙ ПРАВЫЙ

ⒶL TARCZA PRZEDNIA PRAWA



4025089

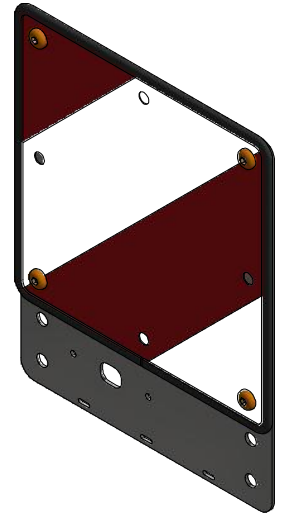
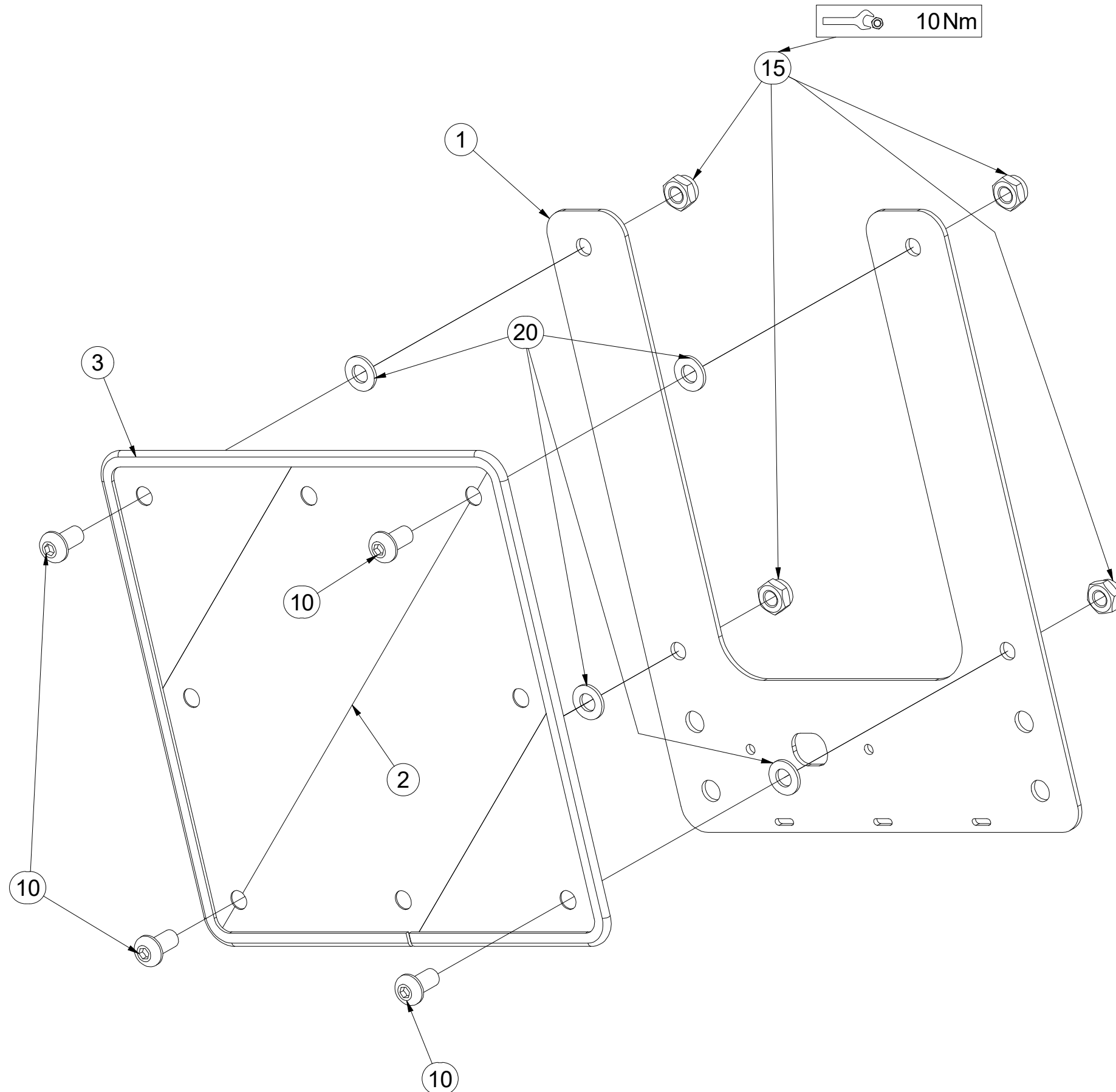

Pos.	Part Number	Pcs.
1	4025090	1
2	m18855	1
3	9005707	1
10	m16637	4
15	m03775	4
20	m01209	4

ⒸZ TERČ ZADNÍ LEVÝ

Ⓓ SCHILD, HINTERES, LINKES

Ⓕ CIBLE ARRIÈRE GAUCHE

ⒼB LEFT REAR DISC

ⒶU ЩИТОК ЗАДНИЙ ЛЕВЫЙ

ⒶL TARCZA TYLNA LEWA



3012398

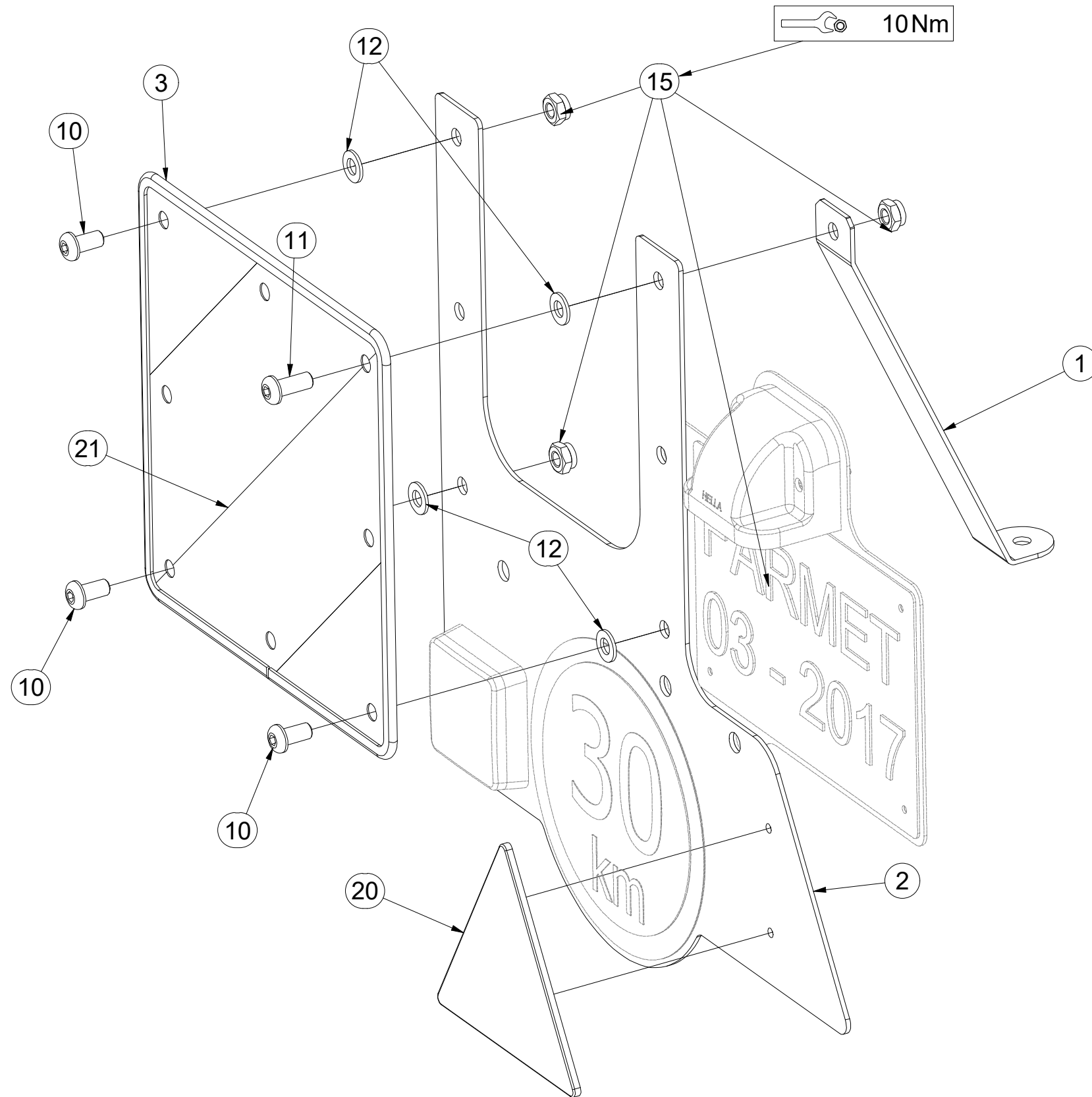

Pos.	Part Number	Pcs.
1	4019310	1
2	4024978	1
3	9005707	1
10	m16637	3
11	m16688	1
12	m01209	4
15	m03775	4
20	m02497	1
21	m18855	1

ⒸZ TERČ ZADNÍ PRAVÝ

Ⓓ SCHILD, HINTERES, RECHTES

Ⓕ CIBLE ARRIÈRE DROITE

ⒼB RIGHT REAR DISC

ⒺU ЩИТОК ЗАДНИЙ ПРАВЫЙ

ⒼL TARCZA TYLNA PRAWA



3012400

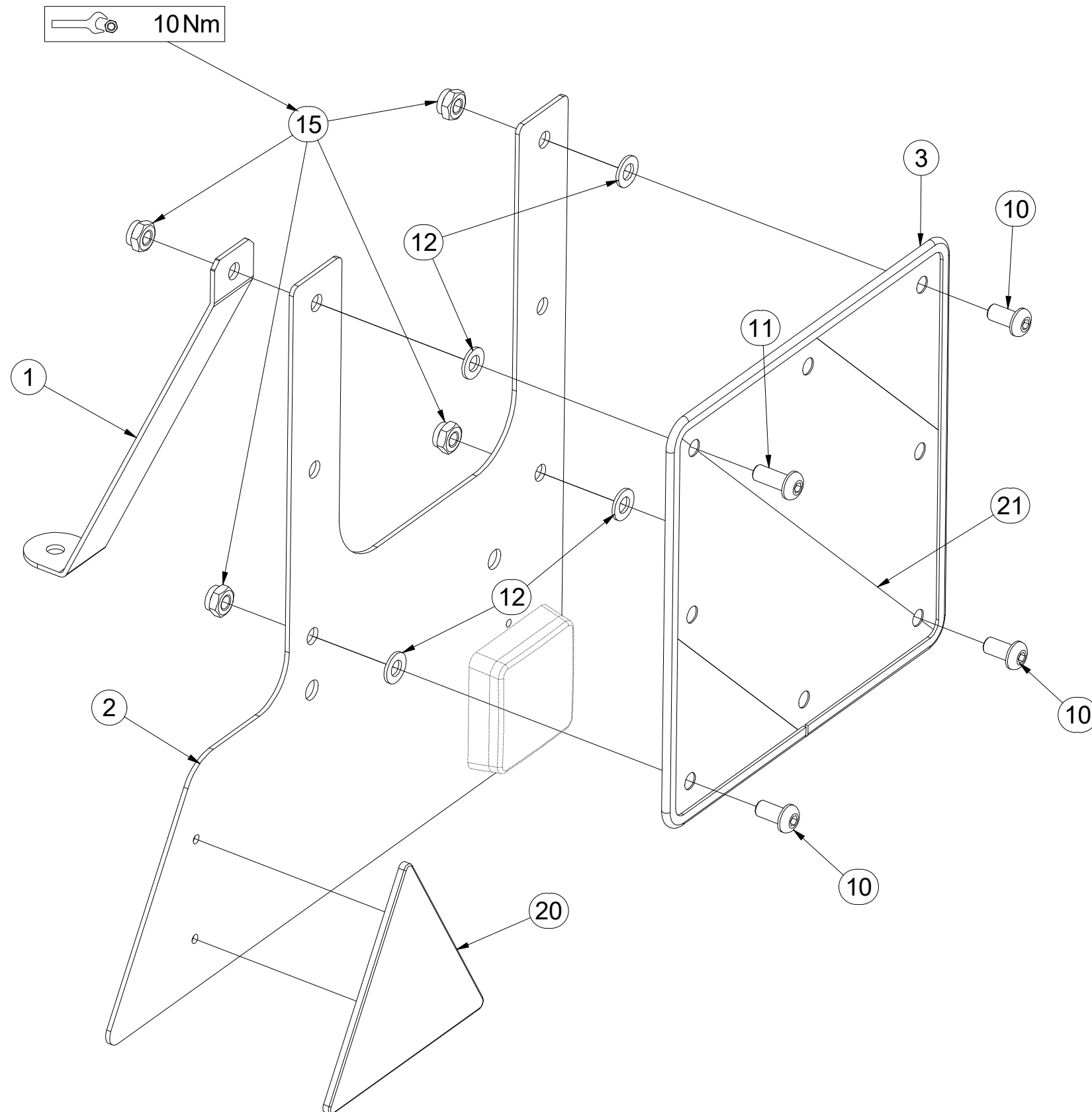

Pos.	Part Number	Pcs.
1	4019310	1
2	4024980	1
3	9005707	1
10	m16637	3
11	m16688	1
12	m01209	4
15	m03775	4
20	m02497	1
21	m18855	1

Ⓒ SADA BRZDOVÁ

Ⓓ BREMSENSATZ

Ⓕ JEU DE FREINS

Ⓖ BRAKE SET

Ⓡ ТОРМОЗНОЙ КОМПЛЕКТ

Ⓟ ZESTAW HAMULCOWY



VZ00020035

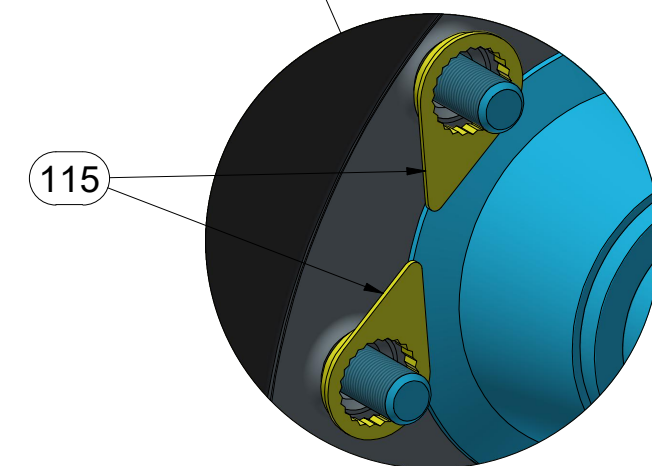
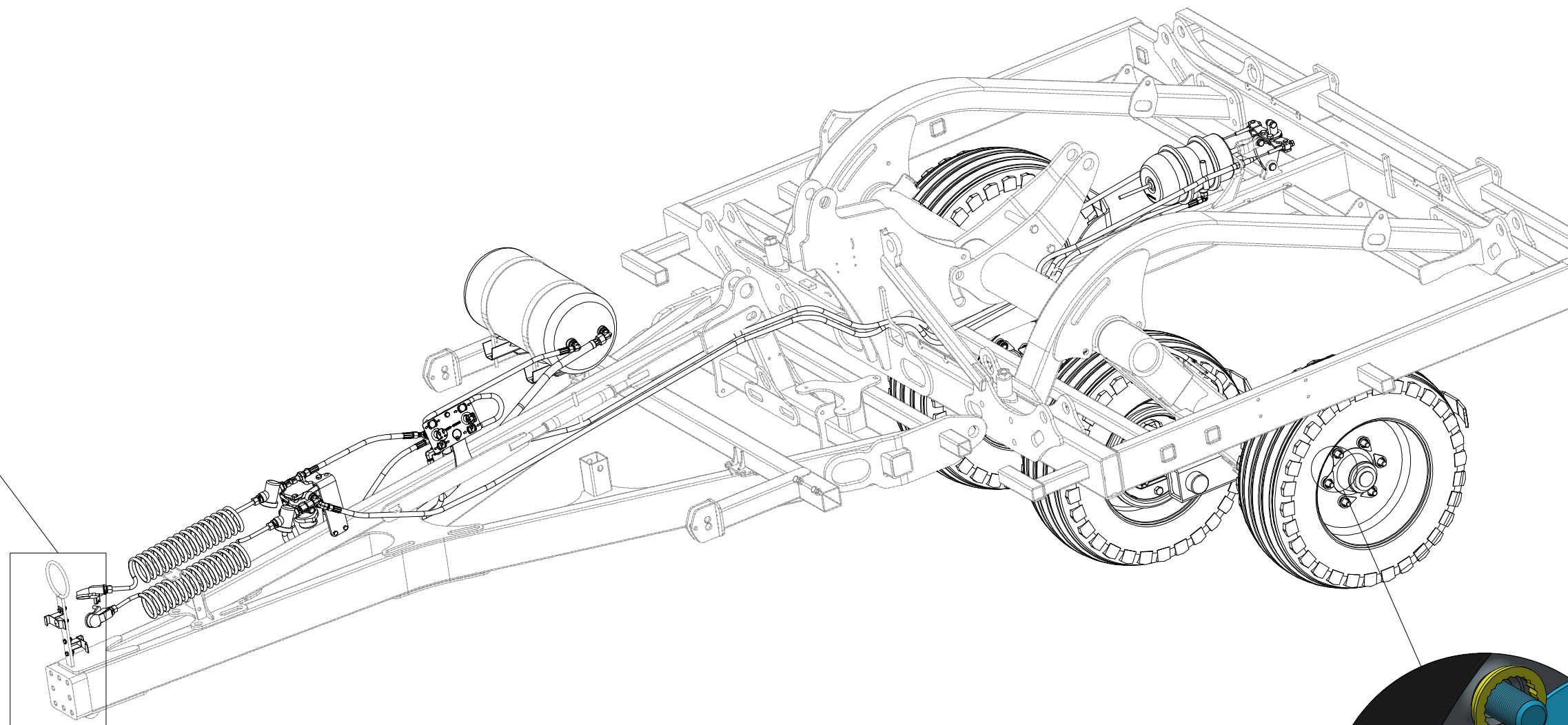
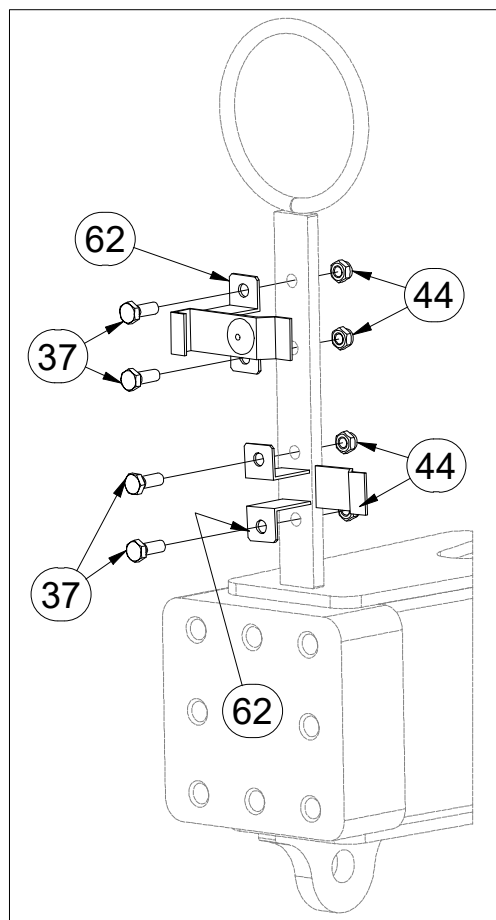

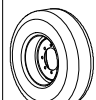
	M18x1,5-265Nm
	350 kPa

Pos.	Part Number	Pcs.
37	m01090	4
44	m04503	11
62	m09789	2
115	m19657	24

ⒸZ SADA BRZDOVÁ

Ⓓ BREMSENSATZ

Ⓕ JEU DE FREINS

VZ00020035

ⒸB BRAKE SET

Ⓔ ТОРМОЗНОЙ КОМПЛЕКТ

Ⓗ ZESTAW HAMULCOWY

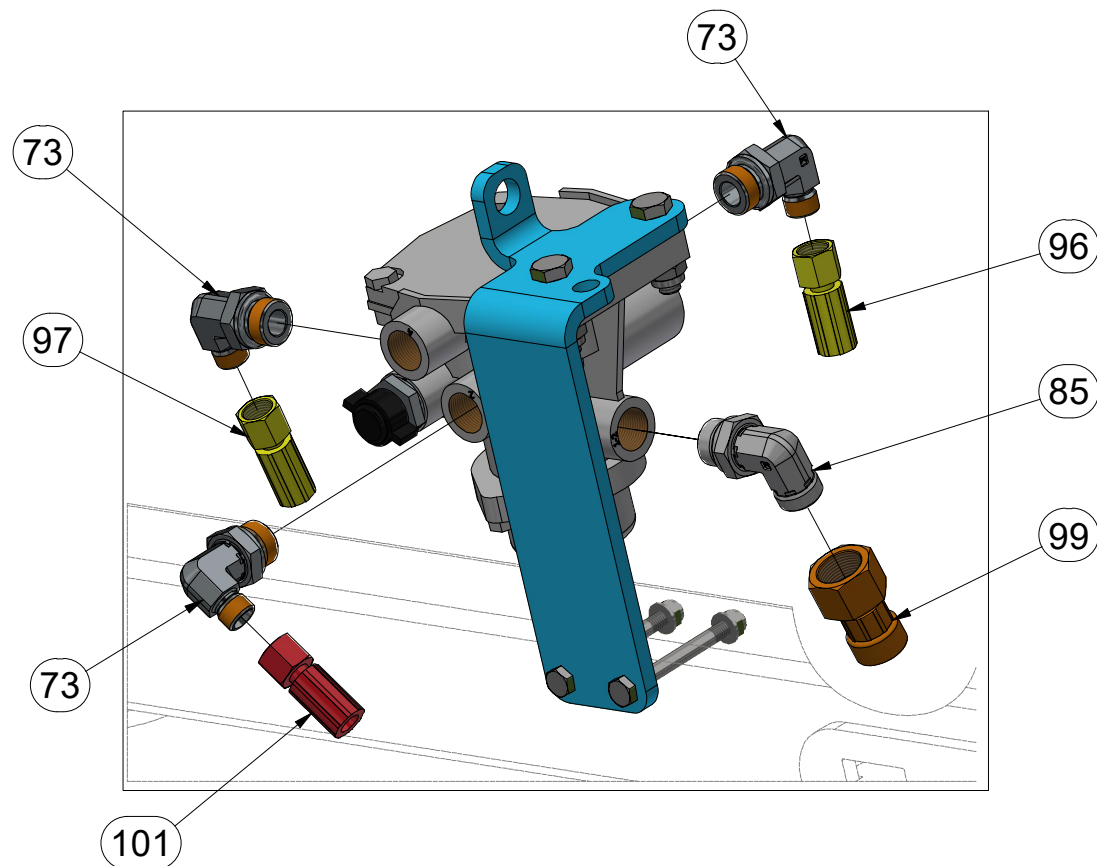
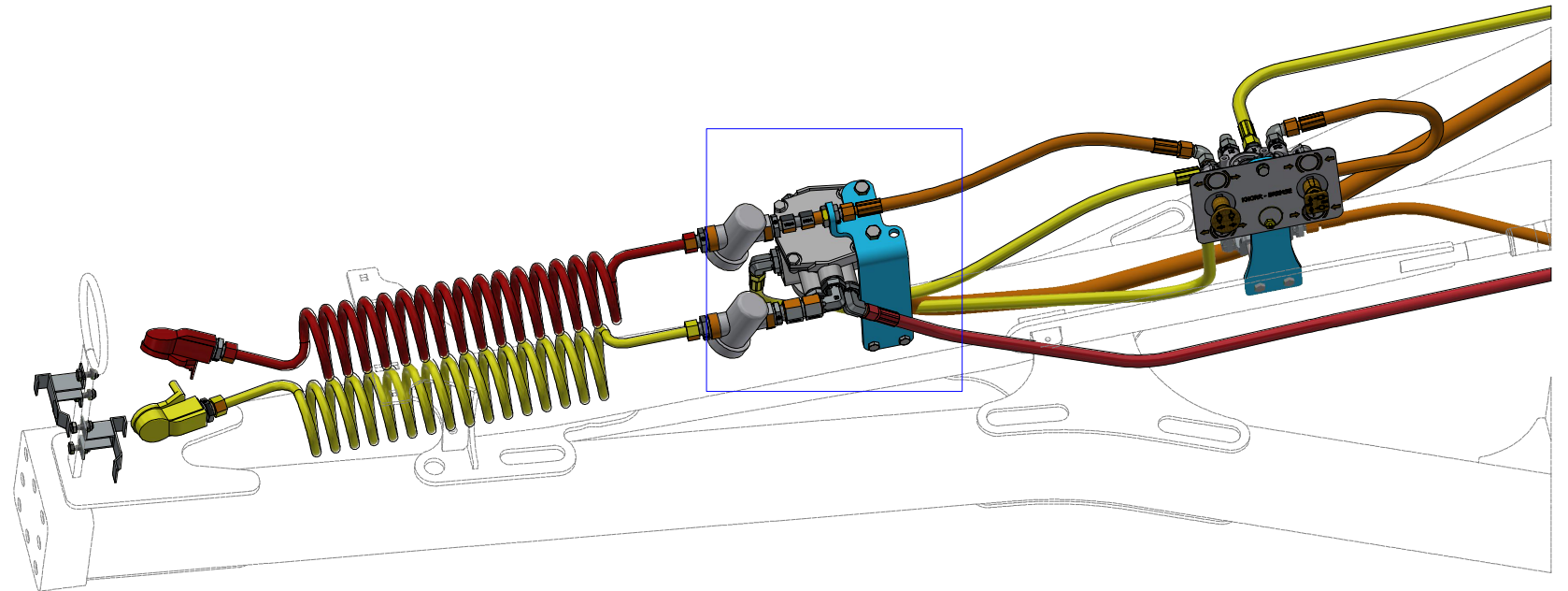
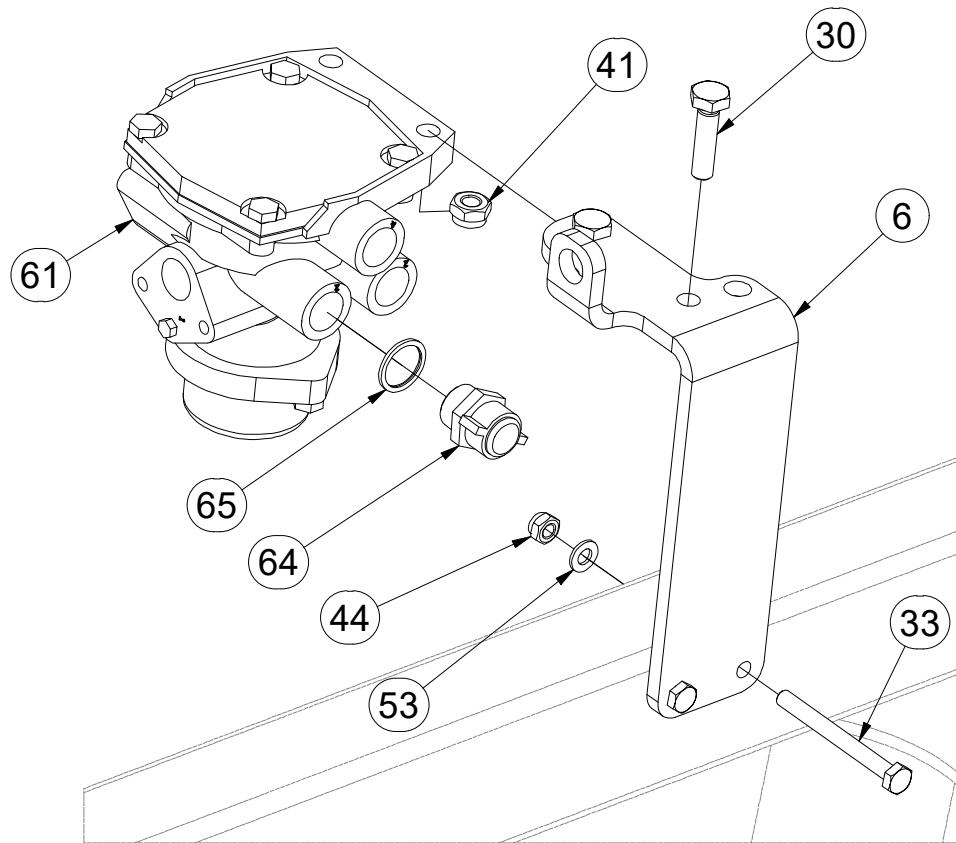

Pos.	Part Number	Pcs.
6	VZ00020133	1
30	m01111	2
33	m16923	2
41	m03775	2
44	m04503	11
53	m01203	3
61	m09784	1
64	m09816	1
65	m09818	4
73	m03890	5
85	m16104	2
96	m10057	1
97	m14727	1
99	m19040	1
101	m10625	1

Ⓒ SADA BRZDOVÁ

Ⓓ BREMSENSATZ

Ⓕ JEU DE FREINS

Ⓖ BRAKE SET

Ⓡ ТОРМОЗНОЙ КОМПЛЕКТ

Ⓟ ZESTAW HAMULCOWY



VZ00020035

Pos.	Part Number	Pcs.
45	m03941	1
66	m11733	2
67	m09948	1
68	m09949	1
71	m11734	1
72	m11735	1
76	m22307	1
77	m07468	1
78	m08261	4
81	m03896	1
82	m11768	1
83	m09934	2
88	m22305	1
95	m15354	2

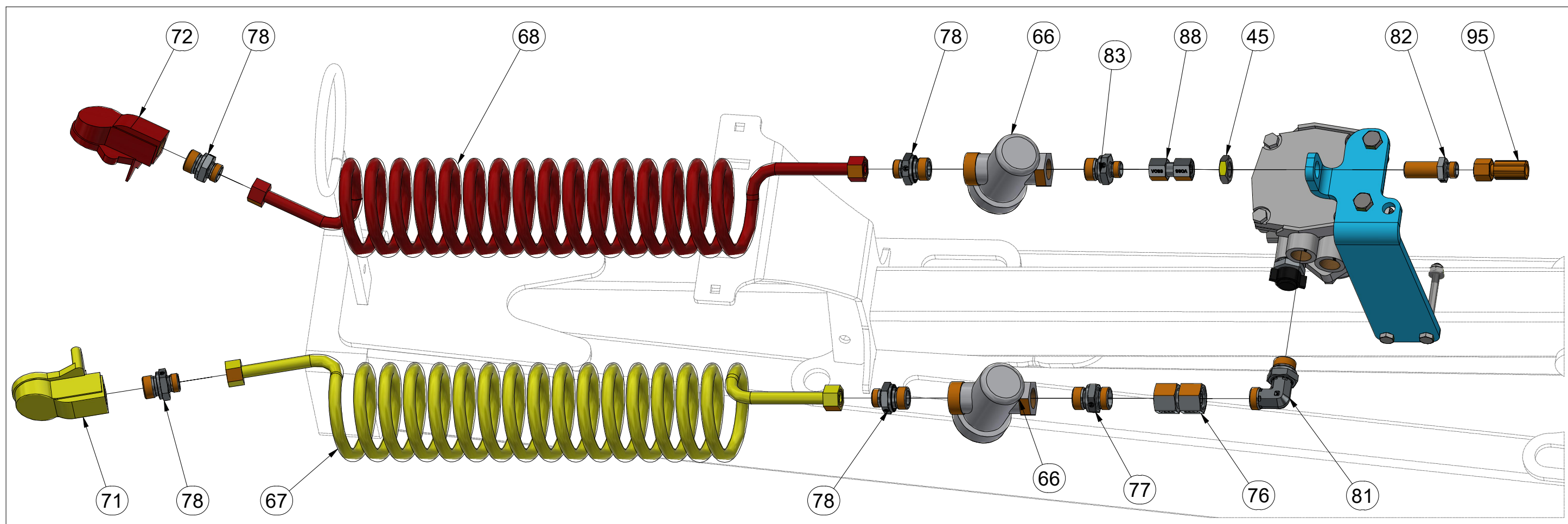
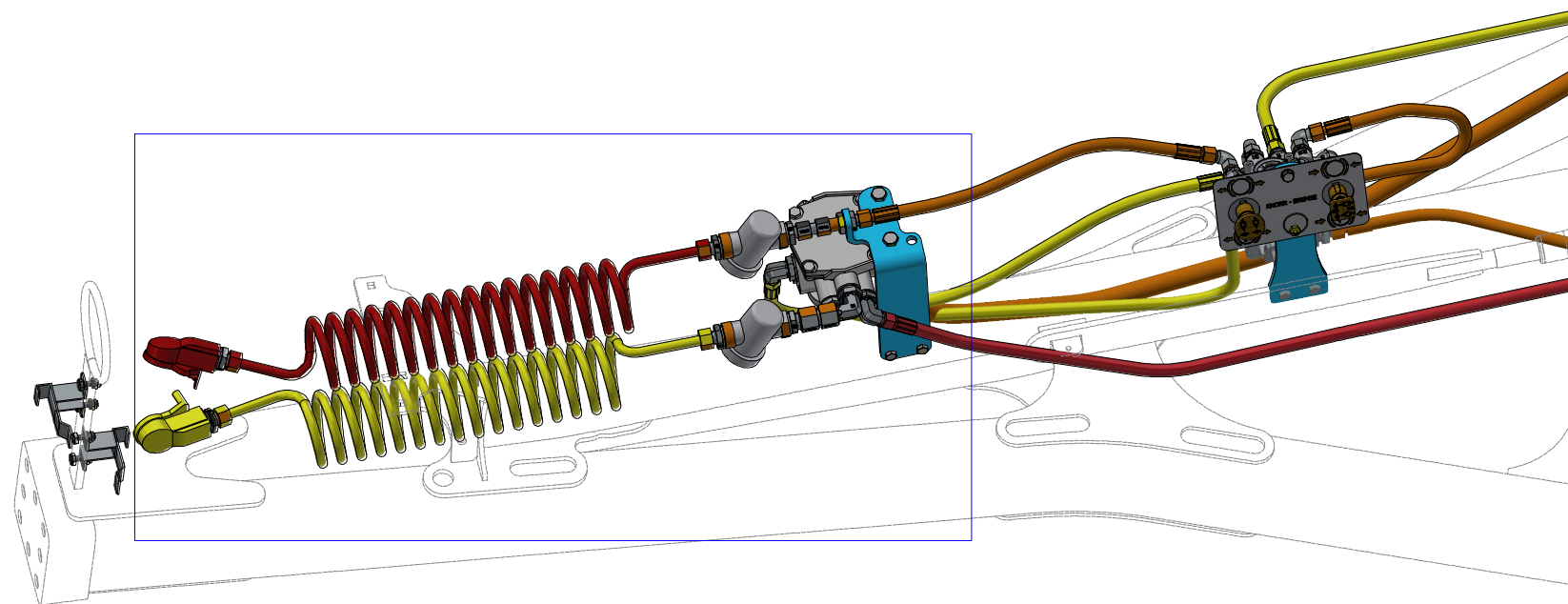

Ⓒ SADA BRZDOVÁ

Ⓓ BREMSENSATZ

Ⓕ JEU DE FREINS

VZ00020035

Ⓖ BRAKE SET

Ⓡ ТОРМОЗНОЙ КОМПЛЕКТ

Ⓢ ZESTAW HAMULCOWY

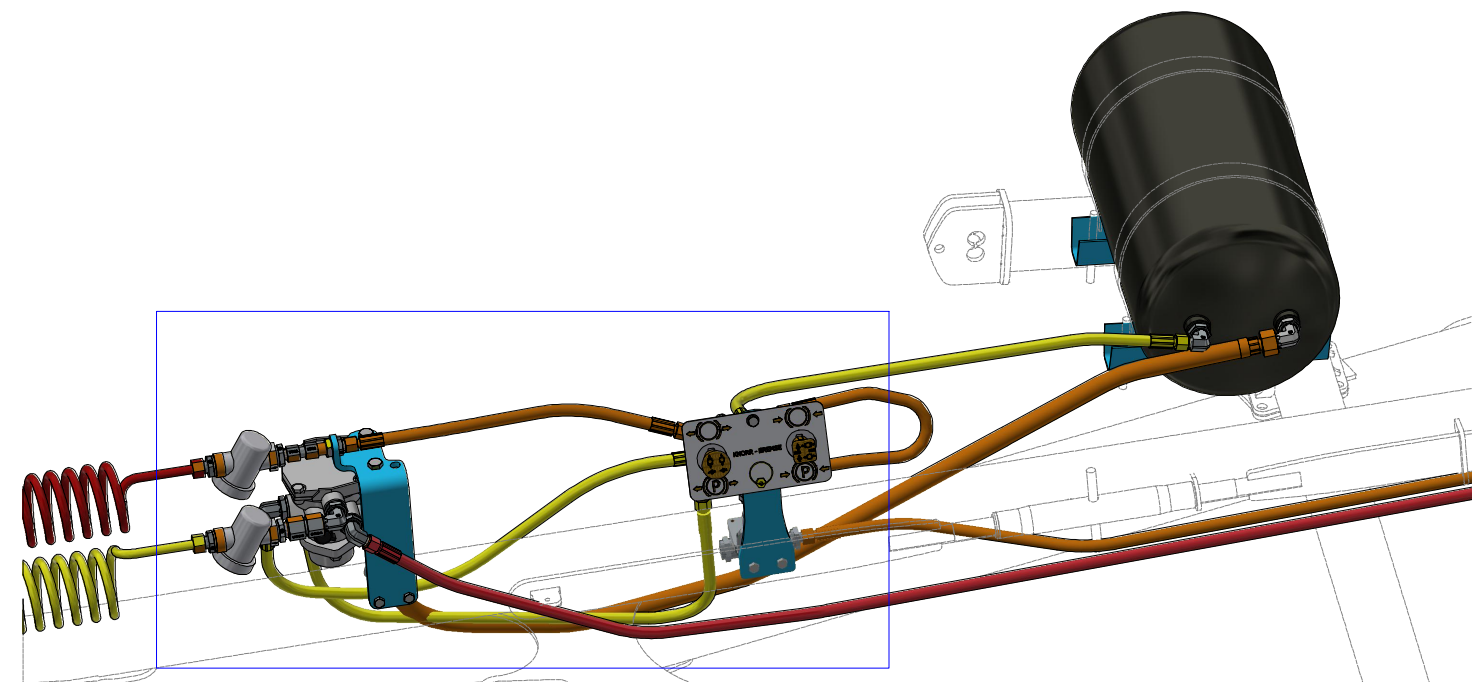
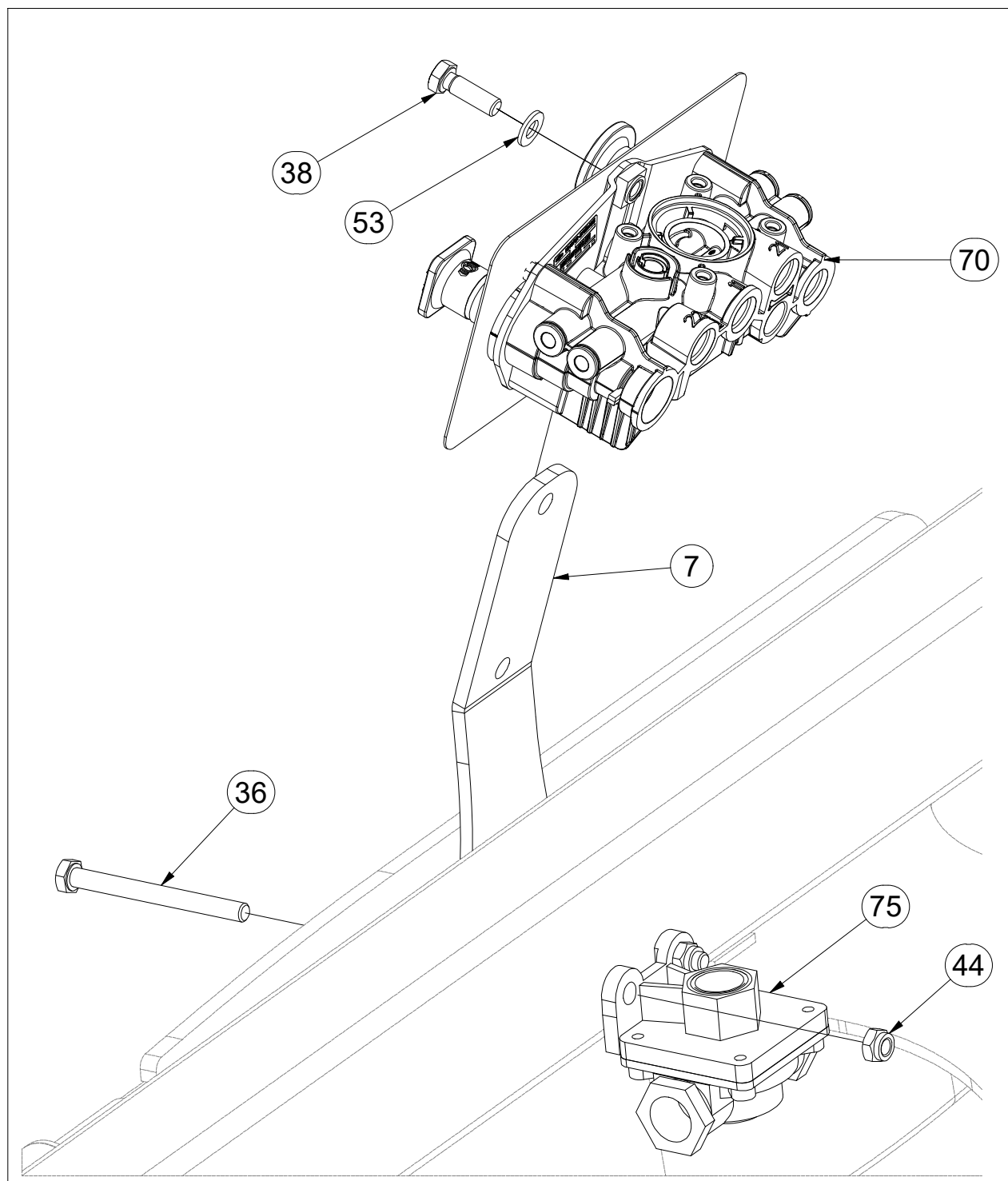

Pos.	Part Number	Pcs.
7	VZ00005407	1
36	m03987	2
38	m01092	3
44	m04503	11
53	m01203	3
70	m17646	1
75	m09791	1

ⒸZ SADA BRZDOVÁ

Ⓓ BREMSENSATZ

Ⓕ JEU DE FREINS

VZ00020035

ⒸB BRAKE SET

Ⓔ ТОРМОЗНОЙ КОМПЛЕКТ

Ⓗ ZESTAW HAMULCOWY

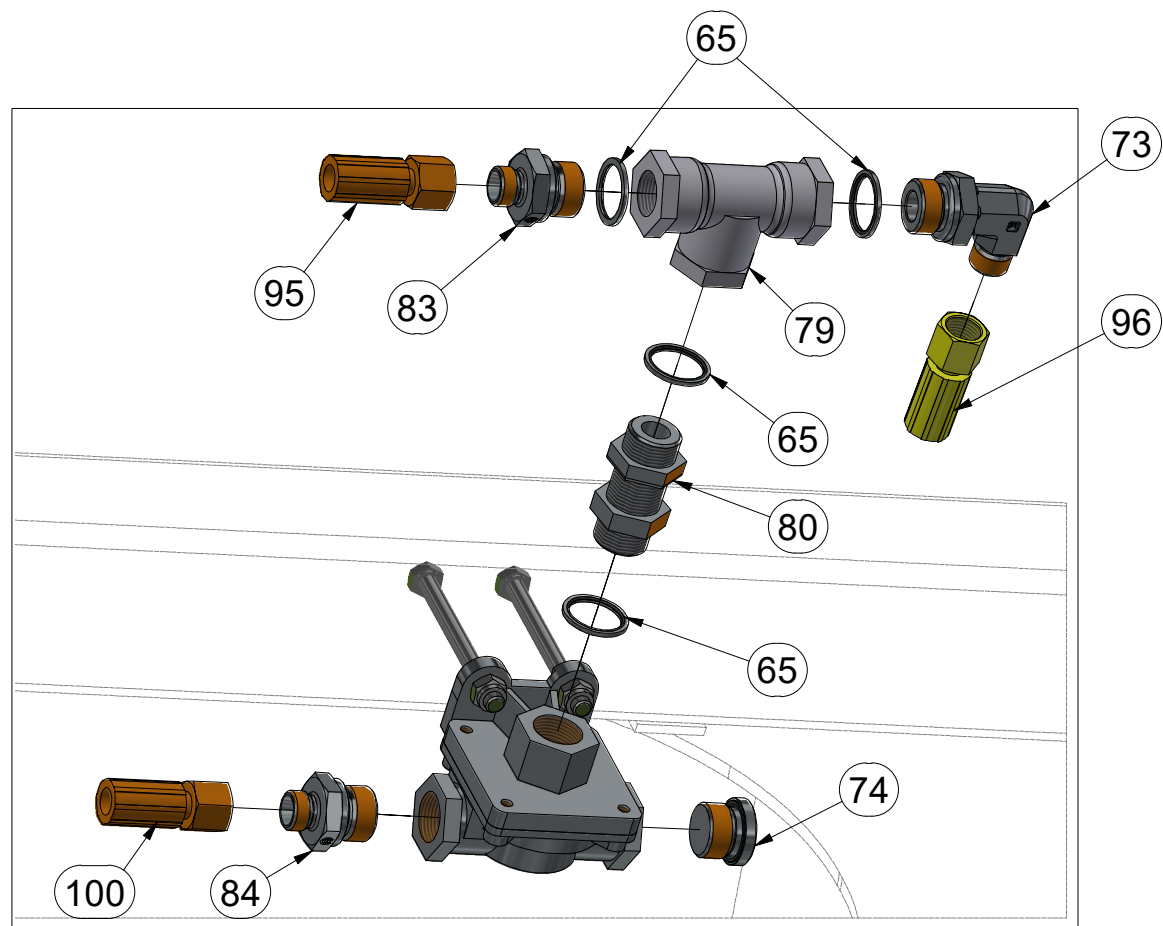
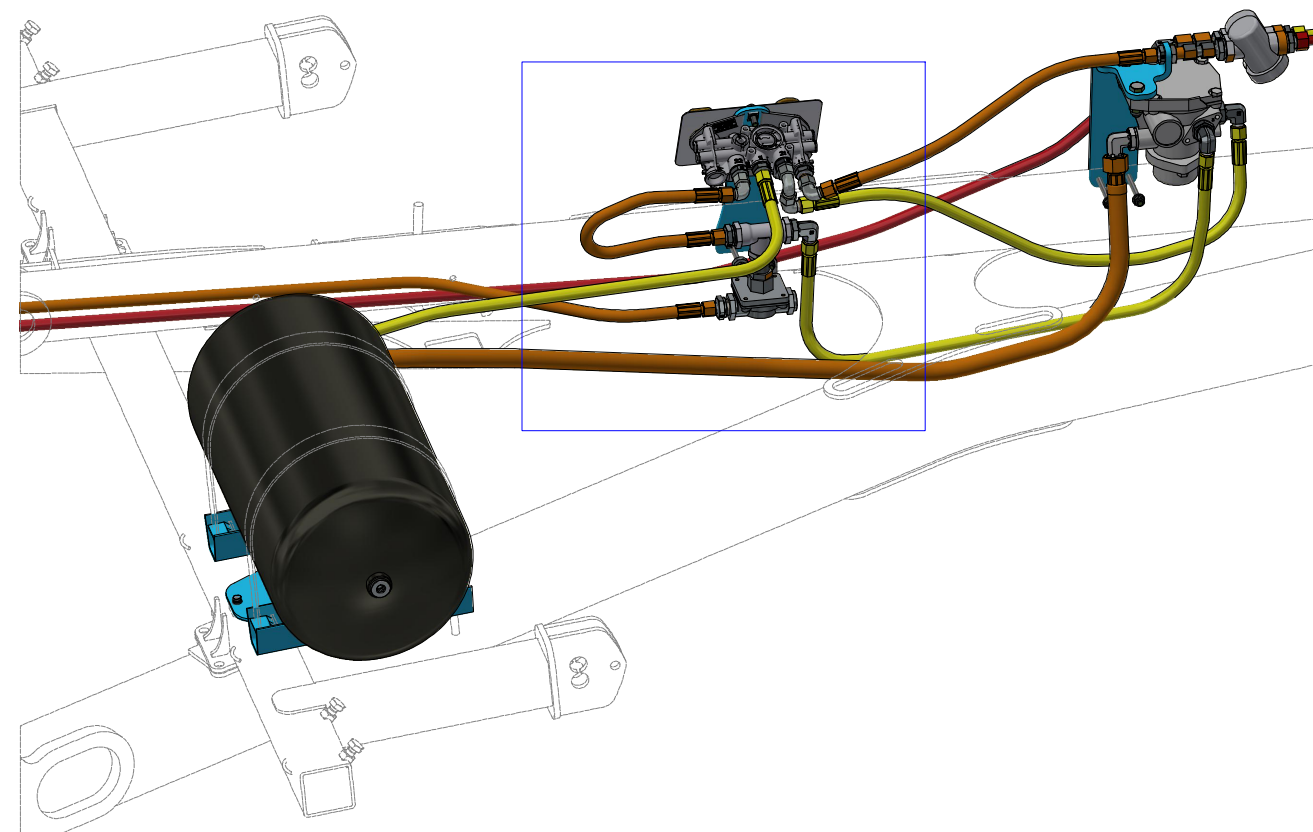
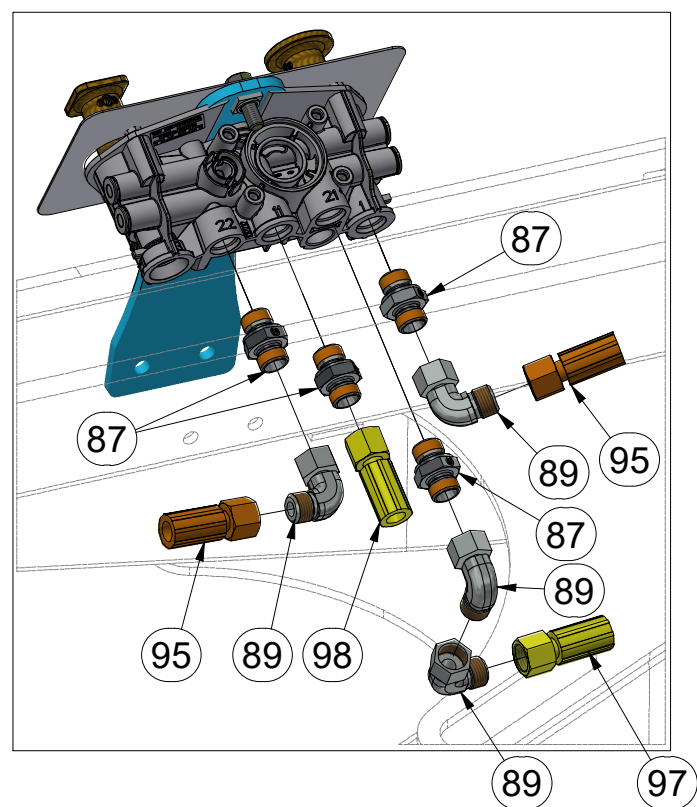

Pos.	Part Number	Pcs.
65	m09818	4
73	m03890	5
74	m04855	2
79	m09785	1
80	m09810	1
83	m09934	2
84	m03925	1
87	m07906	4
89	m06803	4
95	m15354	2
98	m12974	1
97	m14727	1
96	m10057	1
100	m08463	1

Ⓒ SADA BRZDOVÁ

Ⓓ BREMSENSATZ

Ⓕ JEU DE FREINS

VZ00020035

Ⓖ BRAKE SET

Ⓡ ТОРМОЗНОЙ КОМПЛЕКТ

Ⓢ ZESTAW HAMULCOWY

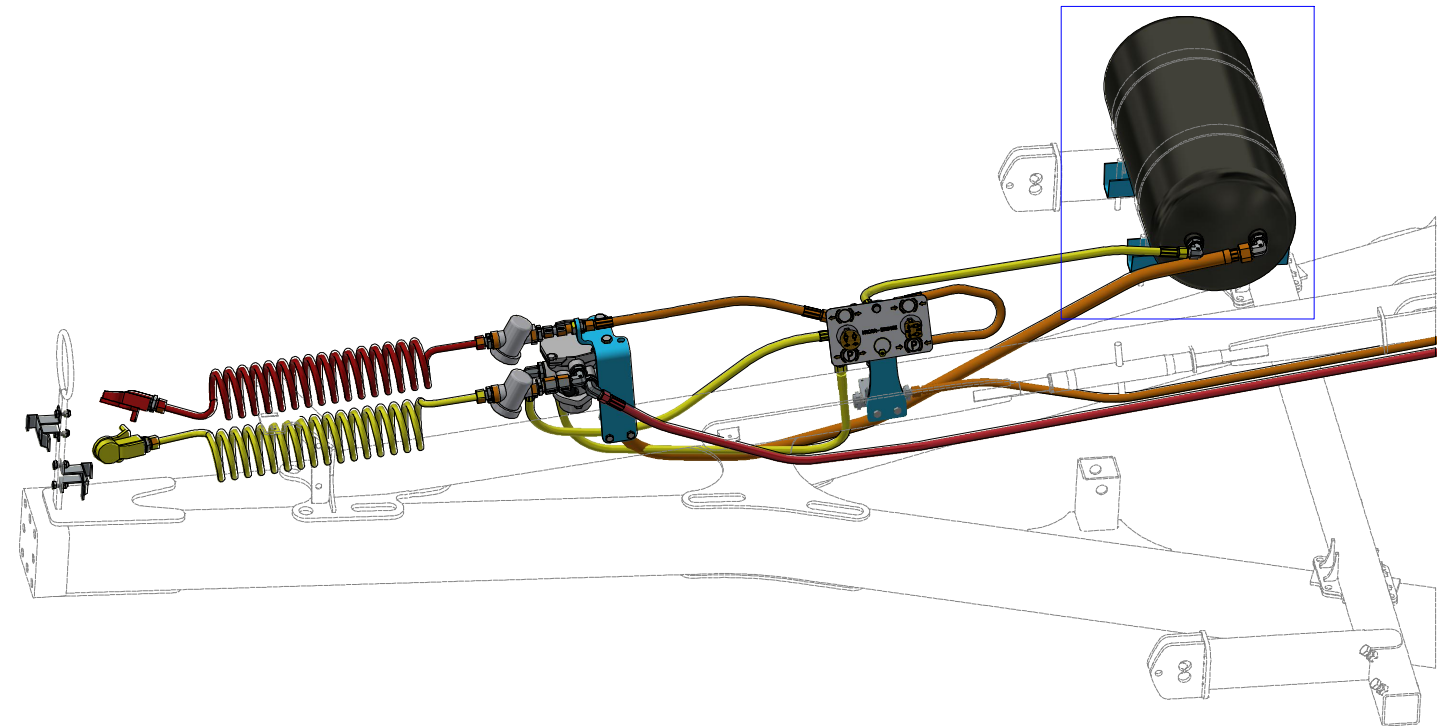
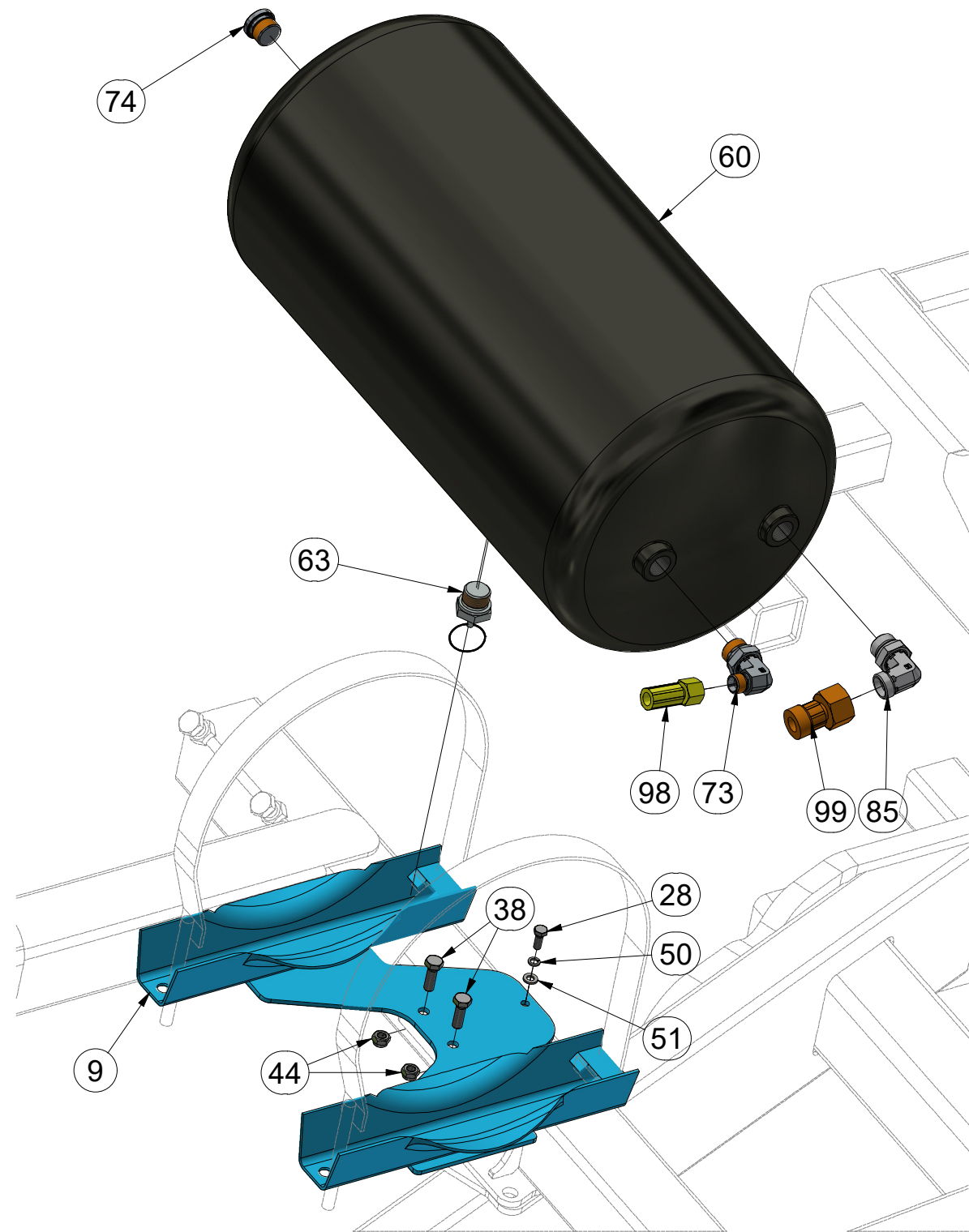

Pos.	Part Number	Pcs.
9	VZ00020146	1
28	m01073	1
38	m01092	3
44	m04503	11
50	m01200	11
51	m01199	11
60	m16553	1
63	m09797	1
73	m03890	5
74	m04855	2
85	m16104	2
98	m12974	1
99	m19040	1

Ⓒ SADA BRZDOVÁ

Ⓓ BREMSENSATZ

Ⓕ JEU DE FREINS

VZ00020035

Ⓖ BRAKE SET

Ⓡ ТОРМОЗНОЙ КОМПЛЕКТ

Ⓢ ZESTAW HAMULCOWY

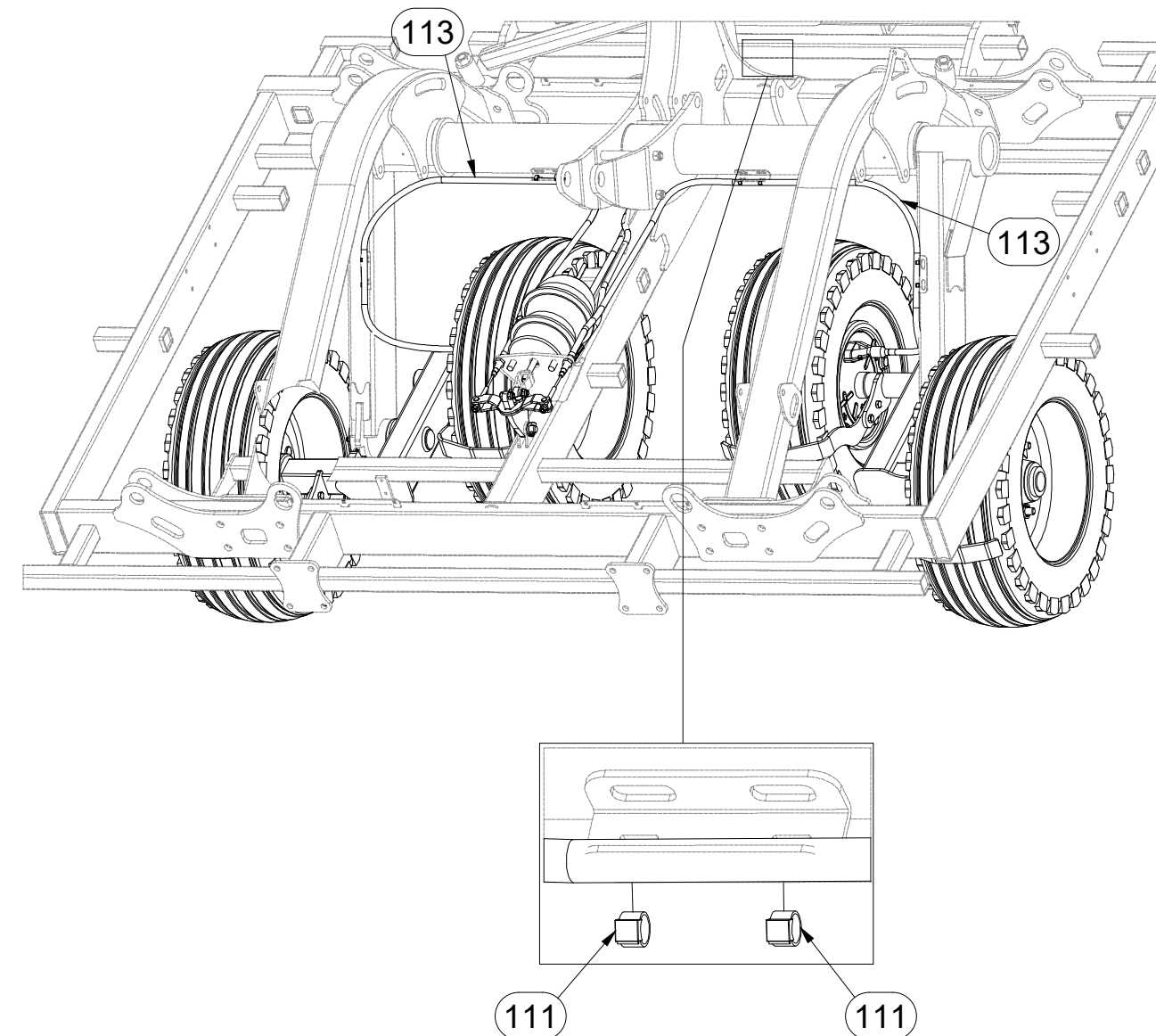
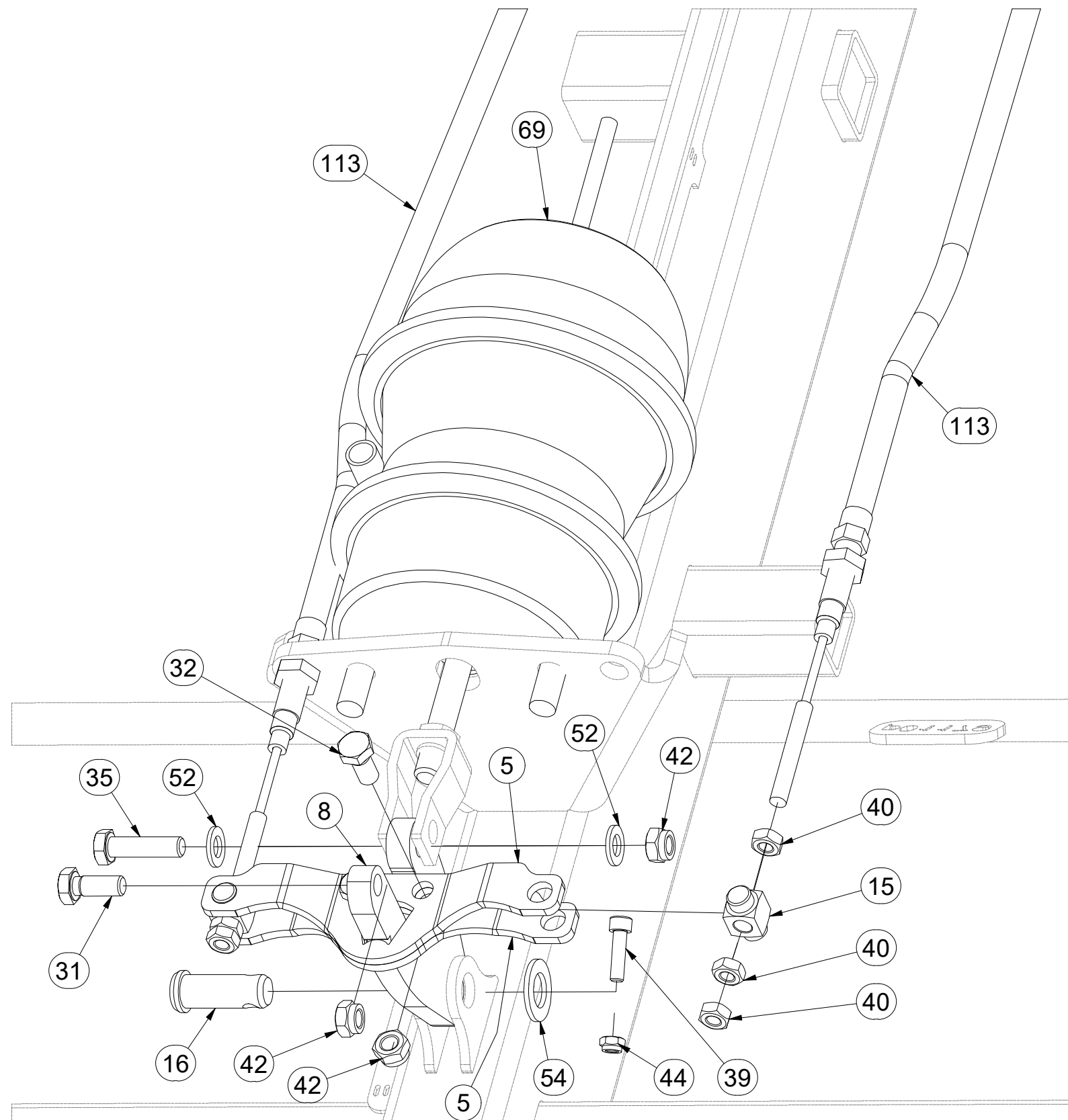

Pos.	Part Number	Pcs.	Pos.	Part Number	Pcs.
5	VZ00020128	2	40	m01299	6
8	VZ00020106	1	42	m04301	12
15	4012584	2	44	m04503	11
16	4015710	1	52	m01214	10
31	m04039	1	54	m03768	1
32	m08549	2	69	VZ00020789	1
35	m06077	1	111	m11253	8
39	m09870	1	113	m15555	2

ⒸZ SADA BRZDOVÁ

Ⓓ BREMSENSATZ

Ⓕ JEU DE FREINS

VZ00020035

ⒸB BRAKE SET

Ⓔ ТОРМОЗНОЙ КОМПЛЕКТ

Ⓖ ZESTAW HAMULCOWY

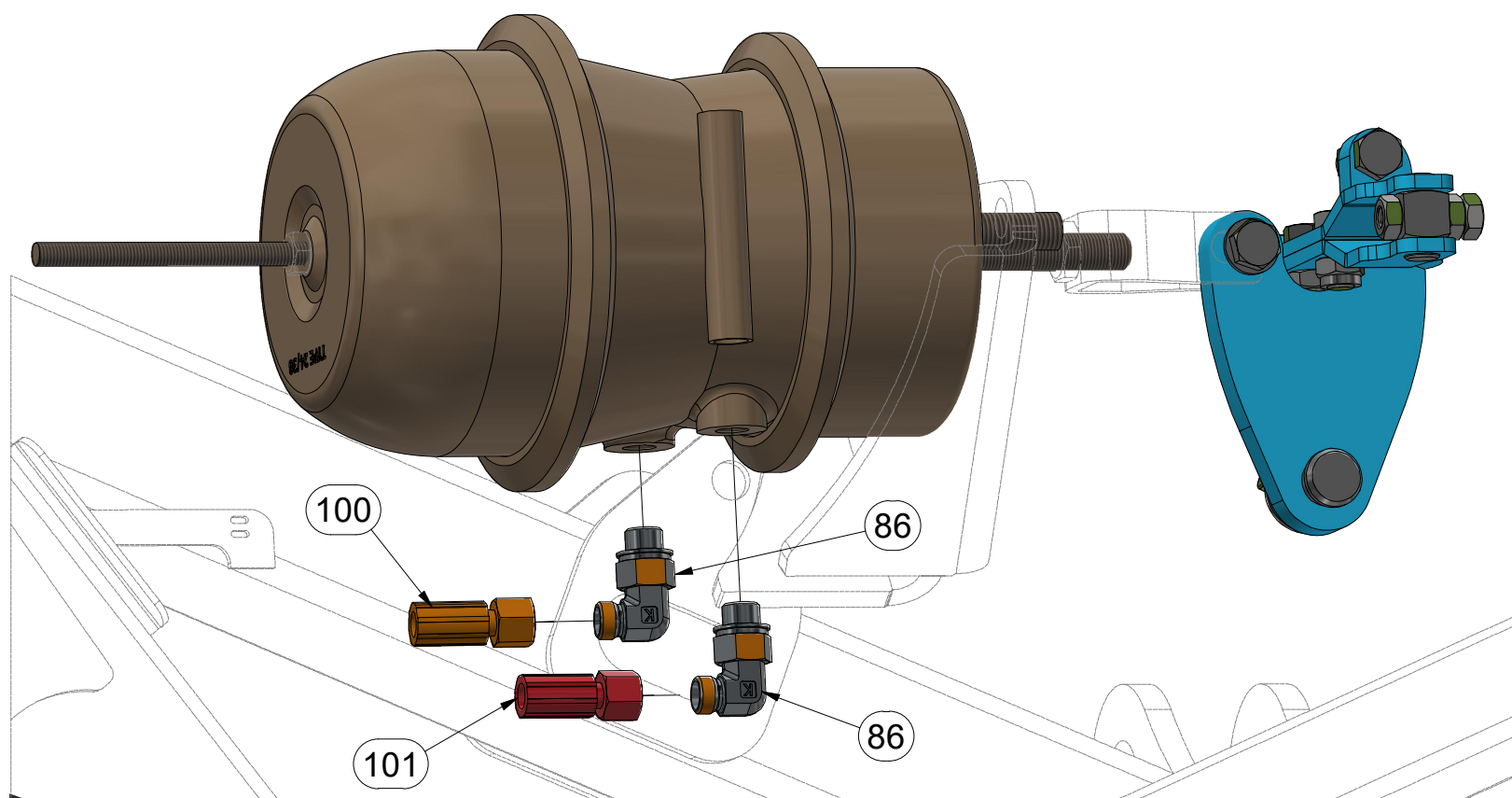
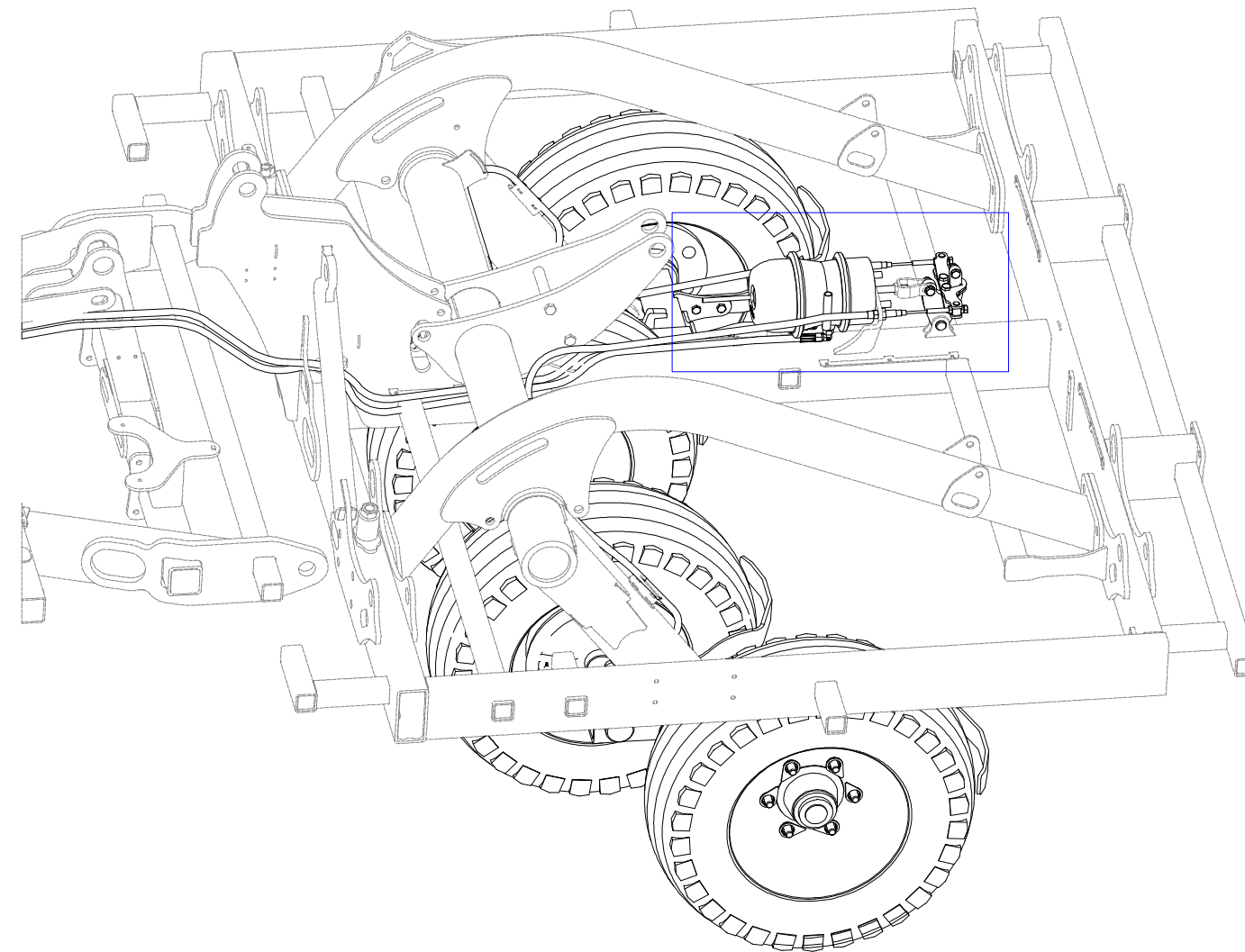

Pos.	Part Number	Pcs.
86	m07483	2
100	m08463	1
101	m10625	1

Ⓒ SADA BRZDOVÁ

Ⓓ BREMSENSATZ

Ⓕ JEU DE FREINS

Ⓖ BRAKE SET

Ⓡ ТОРМОЗНОЙ КОМПЛЕКТ

Ⓟ ZESTAW HAMULCOWY



VZ00020035

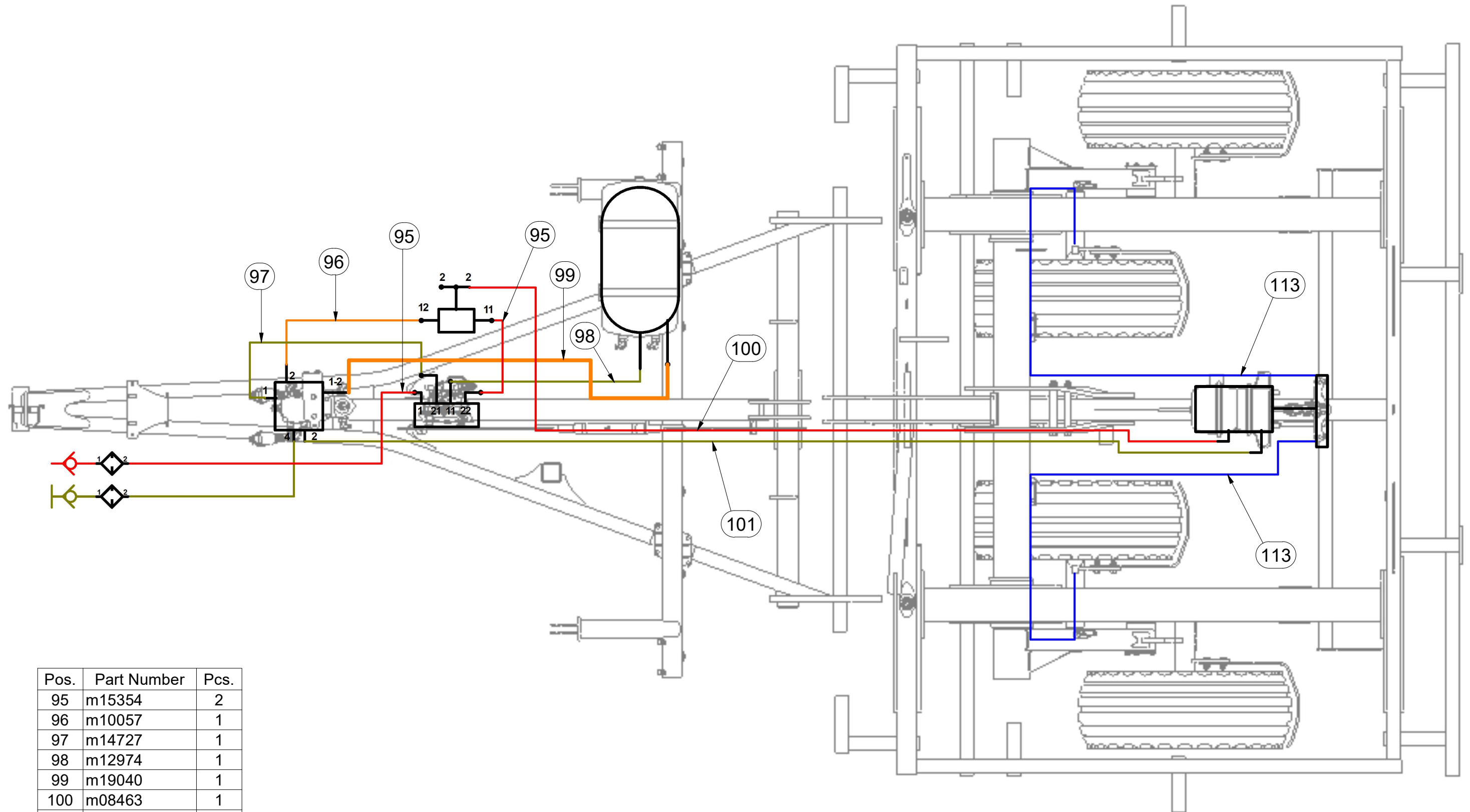

Pos.	Part Number	Pcs.
95	m15354	2
96	m10057	1
97	m14727	1
98	m12974	1
99	m19040	1
100	m08463	1
101	m10625	1
113	m15555	2

Ⓒ SADA BRZDOVÁ

Ⓓ BREMSENSATZ

Ⓕ JEU DE FREINS

Ⓖ BRAKE SET

Ⓡ ТОРМОЗНОЙ КОМПЛЕКТ

Ⓟ ZESTAW HAMULCOWY



VZ00020035

Pos.	Part Number	Pcs.	Pos.	Part Number	Pcs.
1	VZ00015623	1	24	m01725	2
2	VZ00015622	1	29	m01074	10
10	4021953	2	34	m04343	8
11	4021952	2	42	m04301	12
12	4011430	2	43	m12228	2
13	4014913	2	50	m01200	11
20	m19213	4	51	m01199	11
21	m11345	4	52	m01214	10
22	m11109	4			

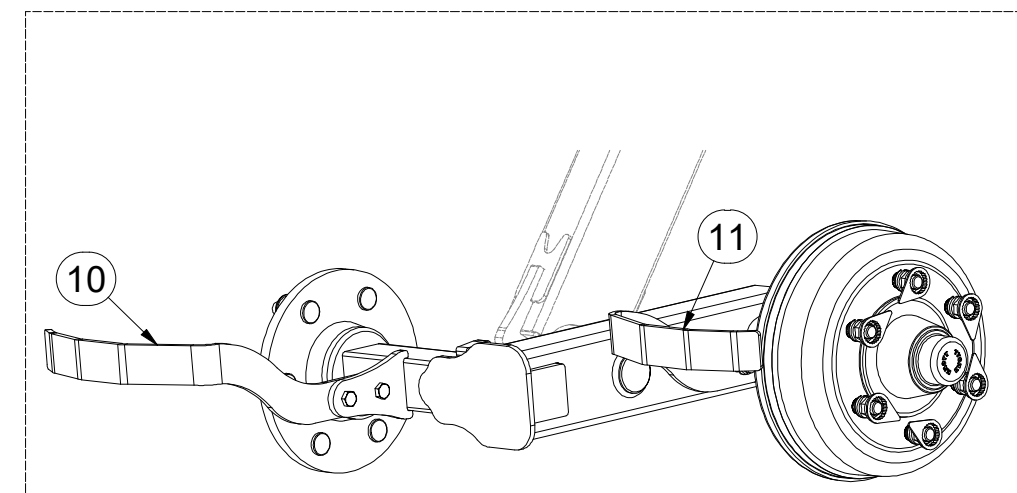
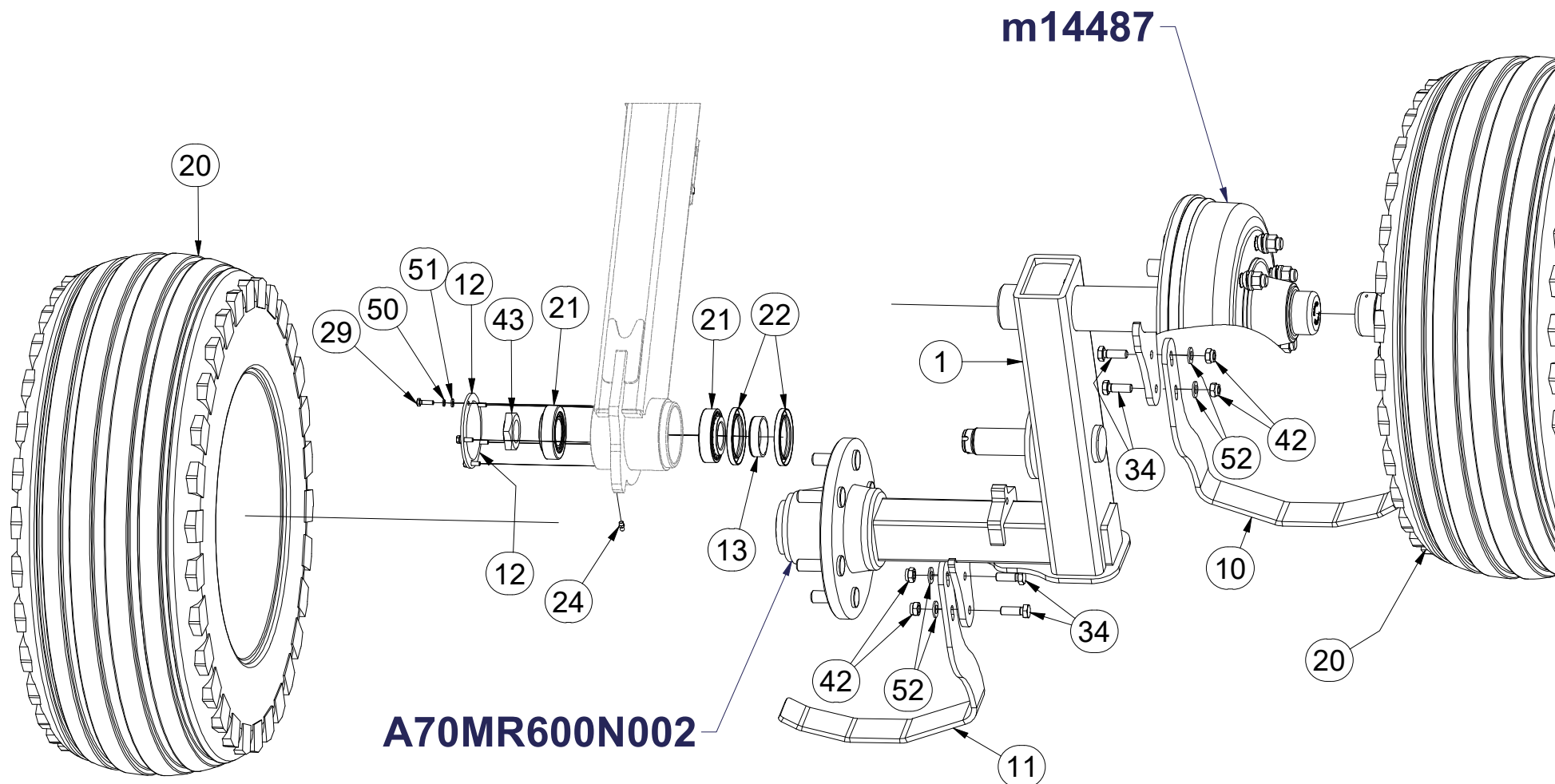
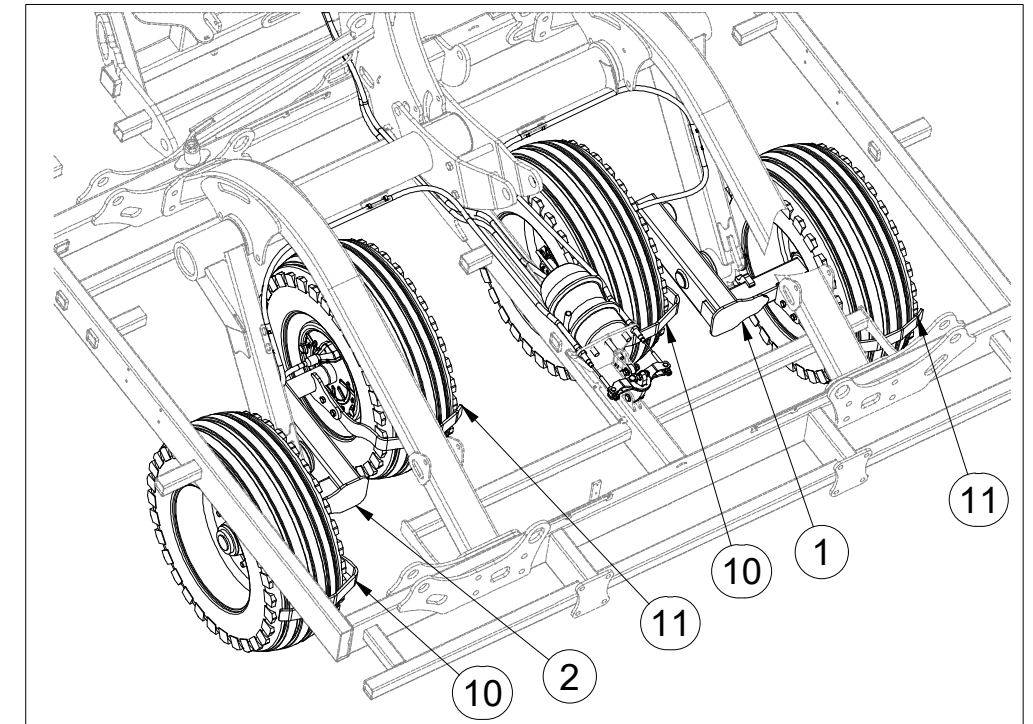
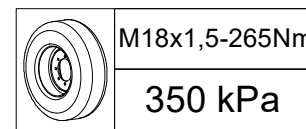

ⒸZ NÁPRAVA

ⒹACHSE

ⒻESSIEU

ⒸGB AXLE

ⒸRU OCB

ⒸPL OS



m14487

Pos.	Part Number	Pcs.
1	m15725	1
2	m15726	1
3	m15727	1
4	m15728	1
5	m15734	1
6	m15733	1
7	m15735	1
8	m15736	1
9	m15737	1
10	m15738	1
11	m15739	1
12	m15724	1
13	m15741	1
14	m15742	2
15	m15743	6
16	m15744	6

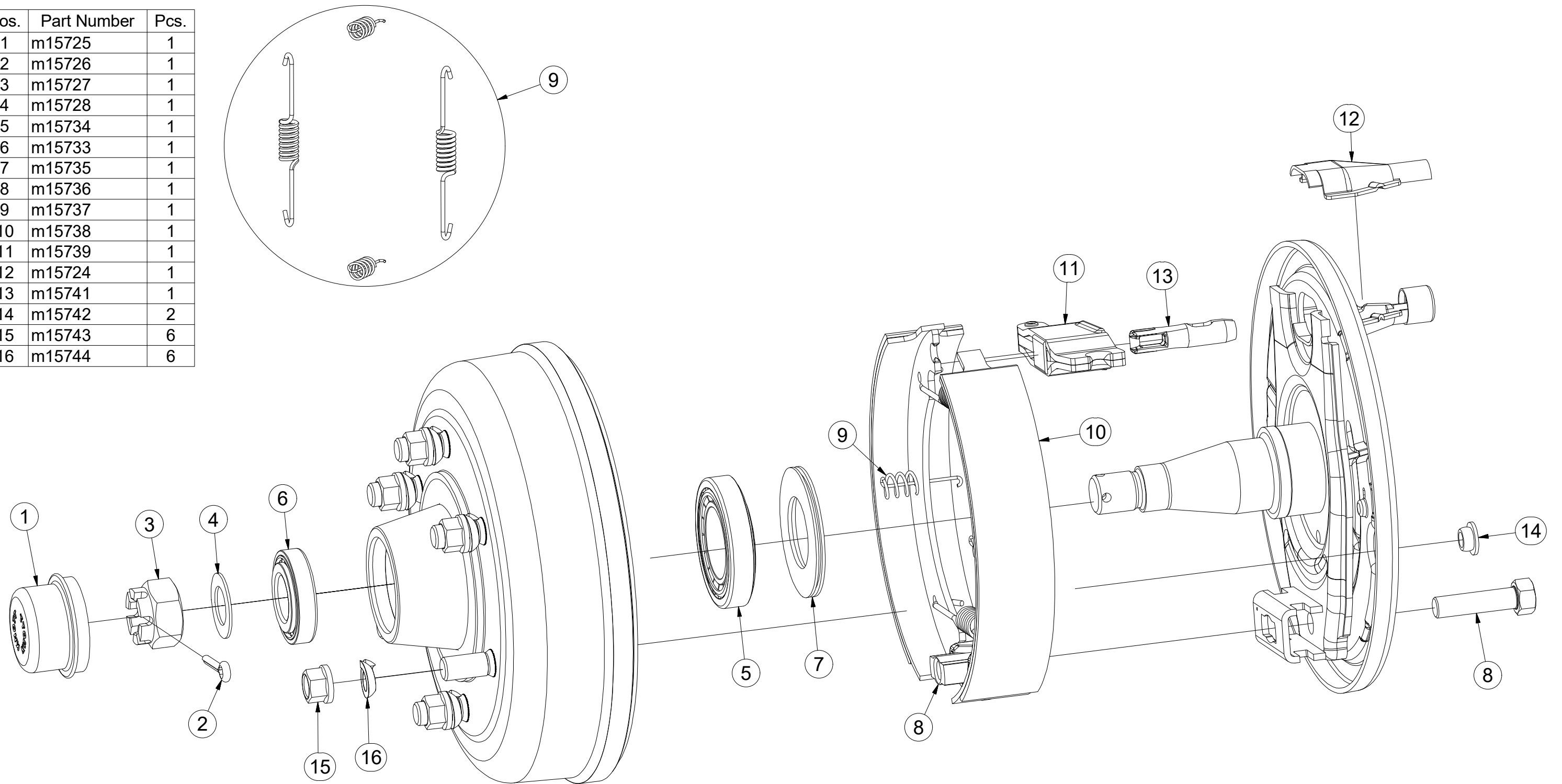

ⒸZ NÁPRAVA

ⒹACHSE

ⒻESSIEU

ⒸGB AXLE

ⒸRU OCB

ⒸPL OS



A70MR06

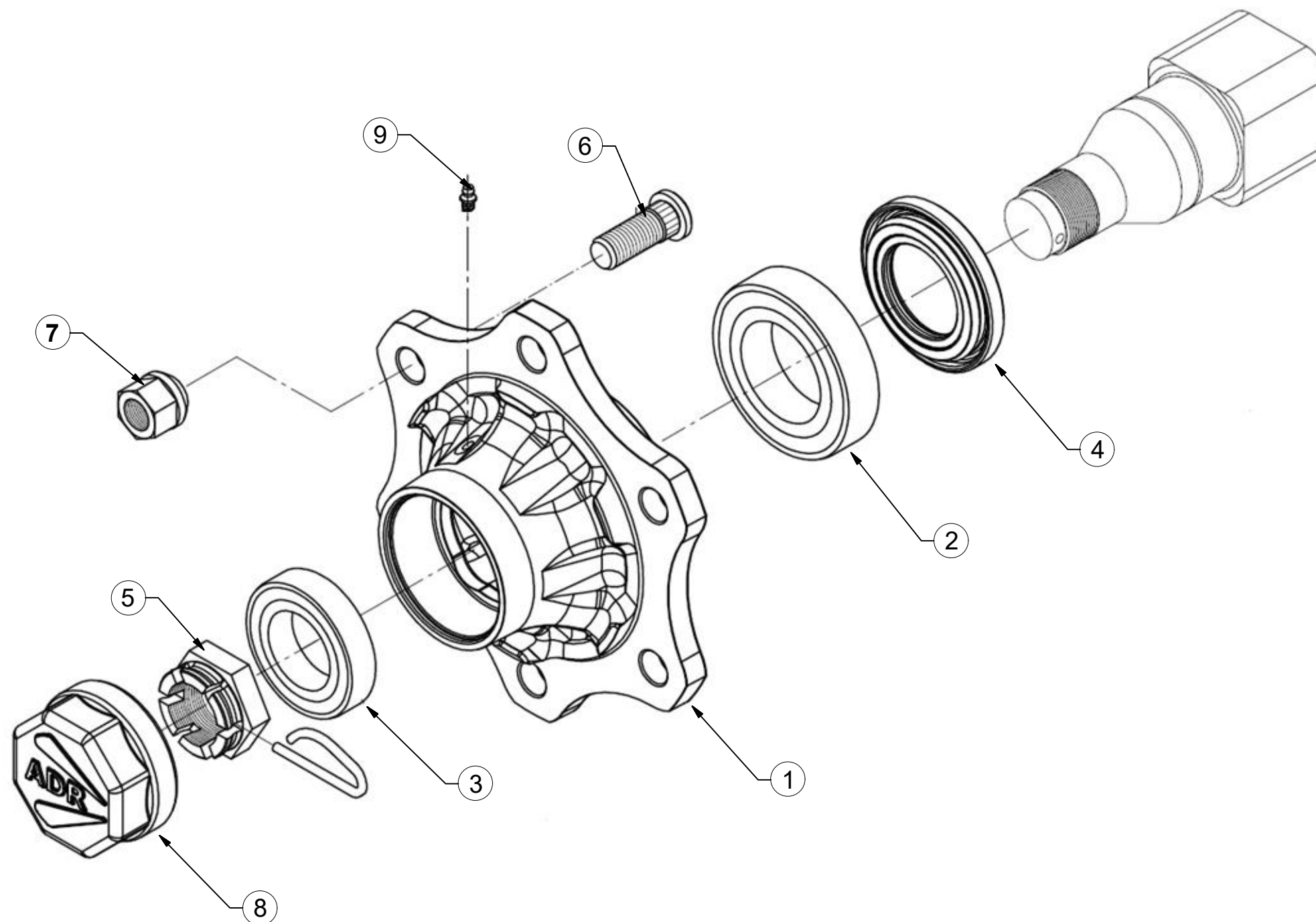

Pos	Part Number	Pcs.
1	m19667	2
2	m08194	2
3	m07152	2
4	m14924	2
5	m08169	2
6	m08148	12
7	m08163	12
8	m19668	2
9	m05698	2

ⒸZ HYDRAULIKA STROJE
Ⓓ HYDRAULIK DER MASCHINE
Ⓕ F HYDRAULIQUE DE LA MACHINE

ⒸB MACHINE HYDRAULICS
ⒸU ГИДРАВЛИКА МАШИНЫ
ⒸL HYDRAULIKA MASZYN



VZ00012055

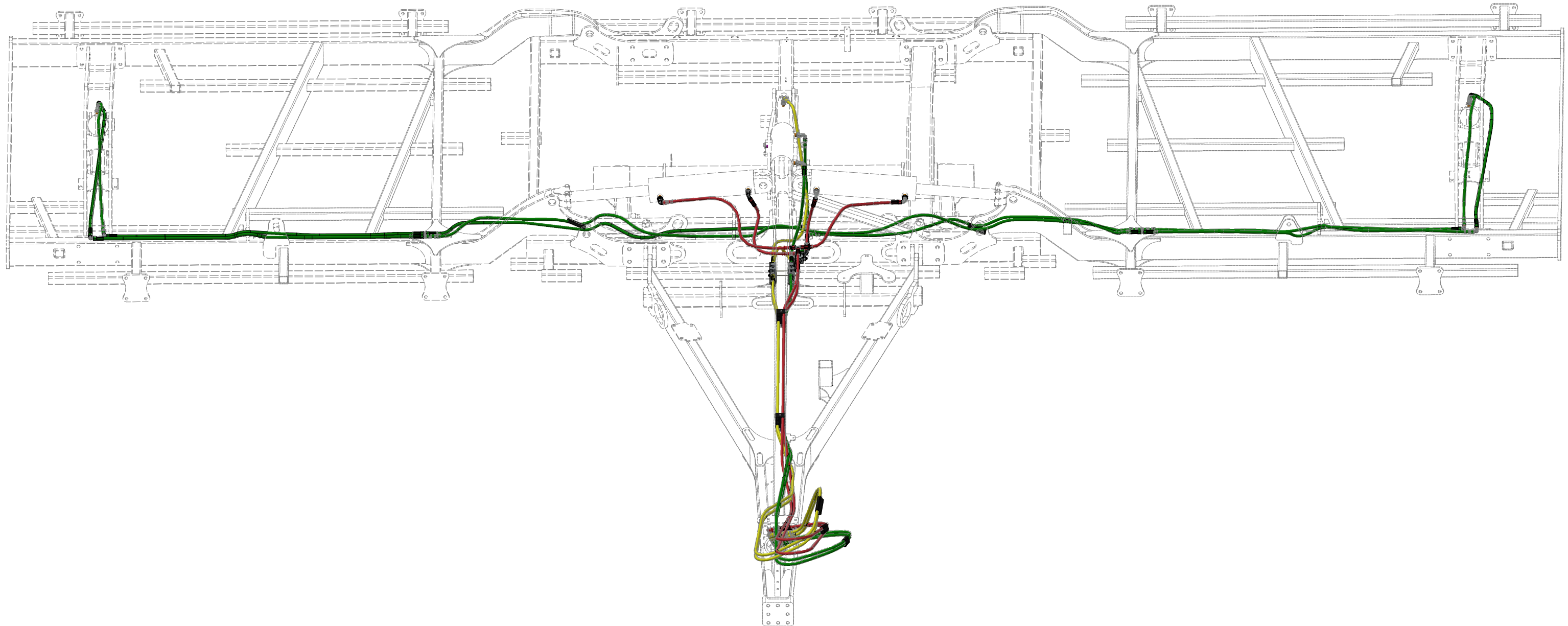

CZ HYDRAULIKA STROJE
 D HYDRAULIK DER MASCHINE
 F HYDRAULIQUE DE LA MACHINE

GB MACHINE HYDRAULICS
 RU ГИДРАВЛИКА МАШИНЫ
 PL HYDRAULIKA MASZYN



VZ00012055

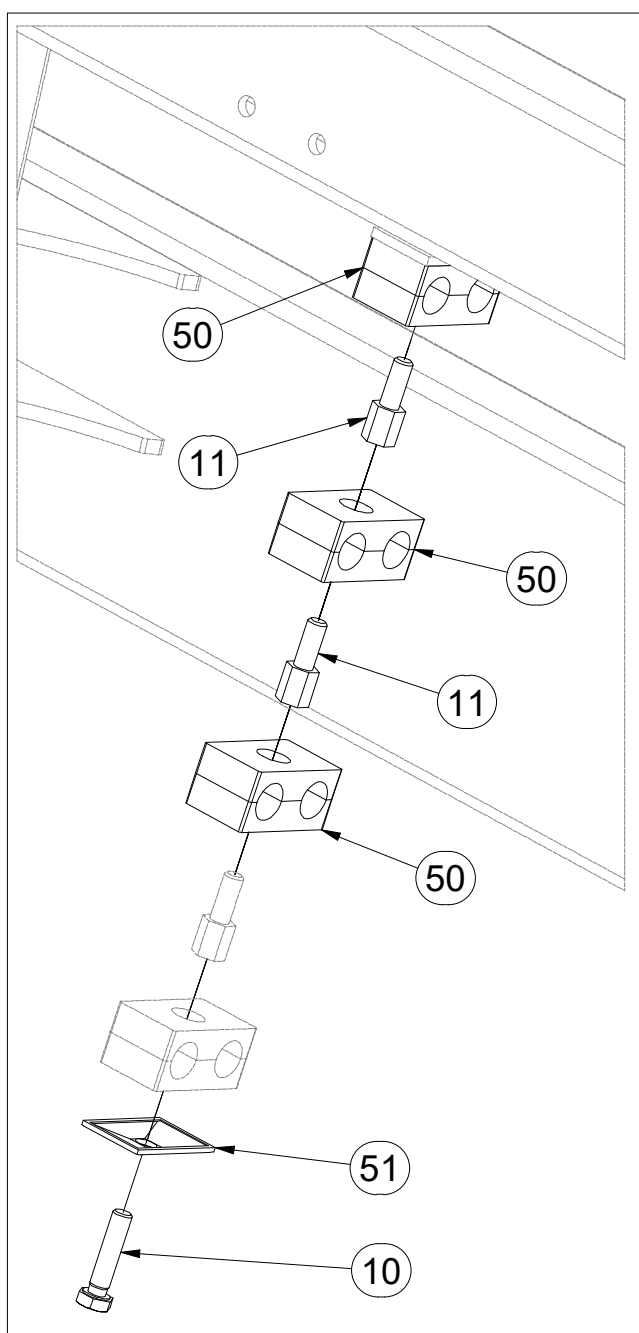
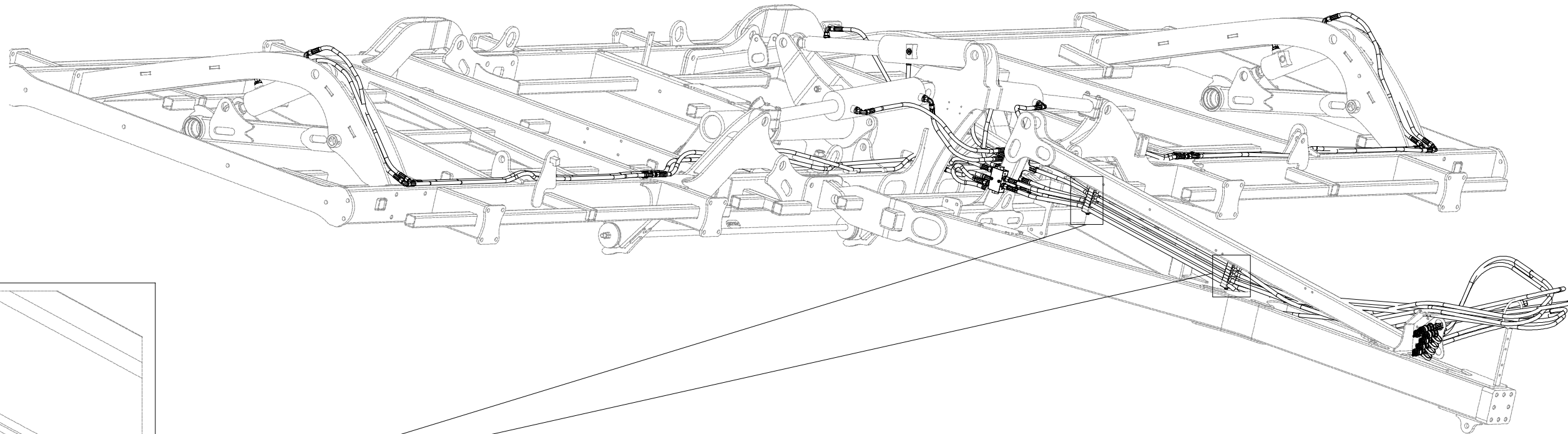

Pos.	Part Number	Pcs.
10	m01096	2
11	m04627	4
50	m04171	6
51	m04173	2

VZ00012055

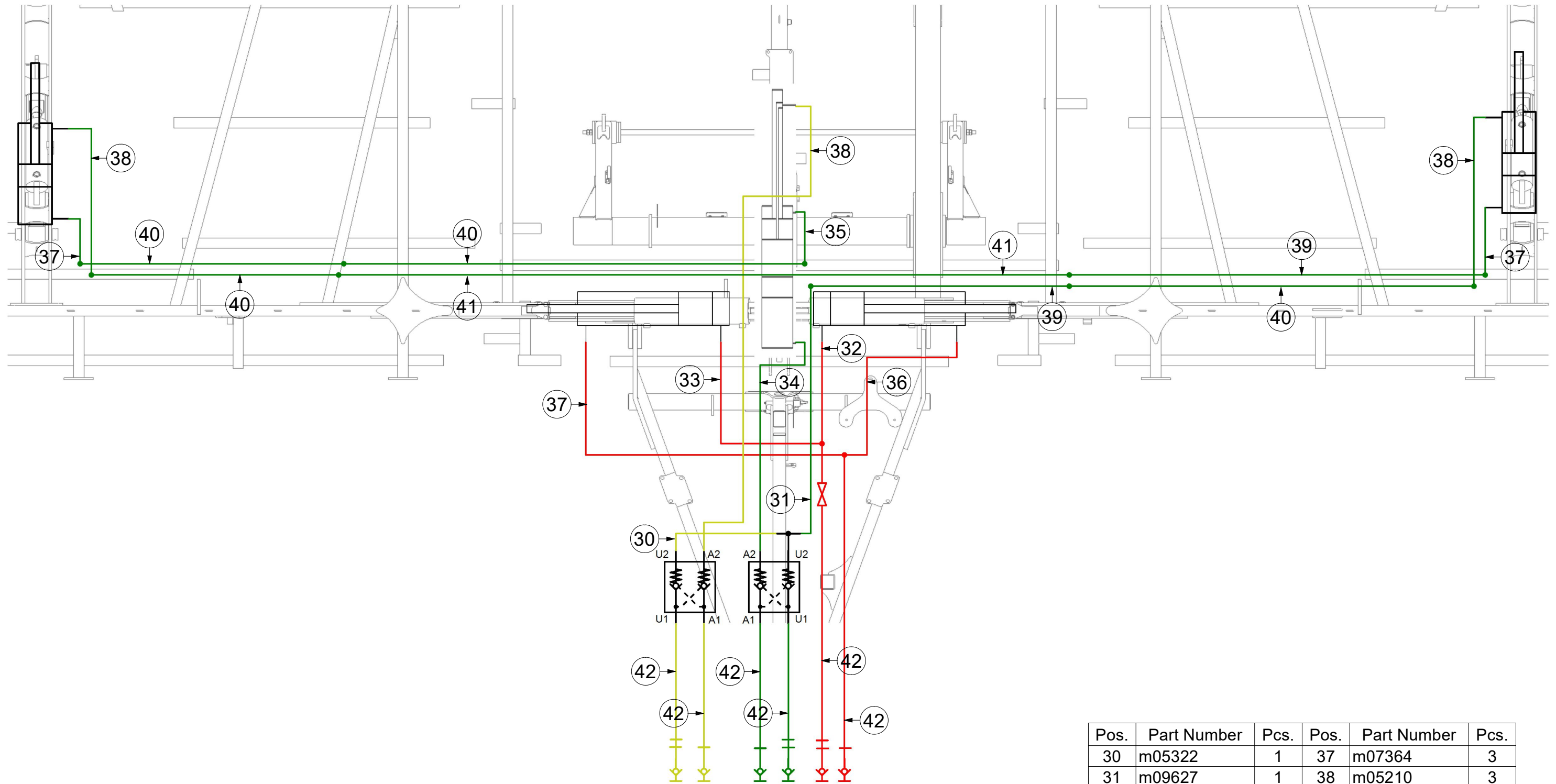

Pos.	Part Number	Pcs.	Pos.	Part Number	Pcs.
30	m05322	1	37	m07364	3
31	m09627	1	38	m05210	3
32	m17441	1	39	m07648	2
33	m09628	1	40	m11696	4
34	m04761	1	41	m12025	1
35	m09629	1	42	m05216	6
36	m04033	1			

(CZ) HYDRAULIKA STROJE
 (D) HYDRAULIK DER MASCHINE
 (F) HYDRAULIQUE DE LA MACHINE

(GB) MACHINE HYDRAULICS
 (RU) ГИДРАВЛИКА МАШИНЫ
 (PL) HYDRAULIKA MASZYNY



VZ00012055

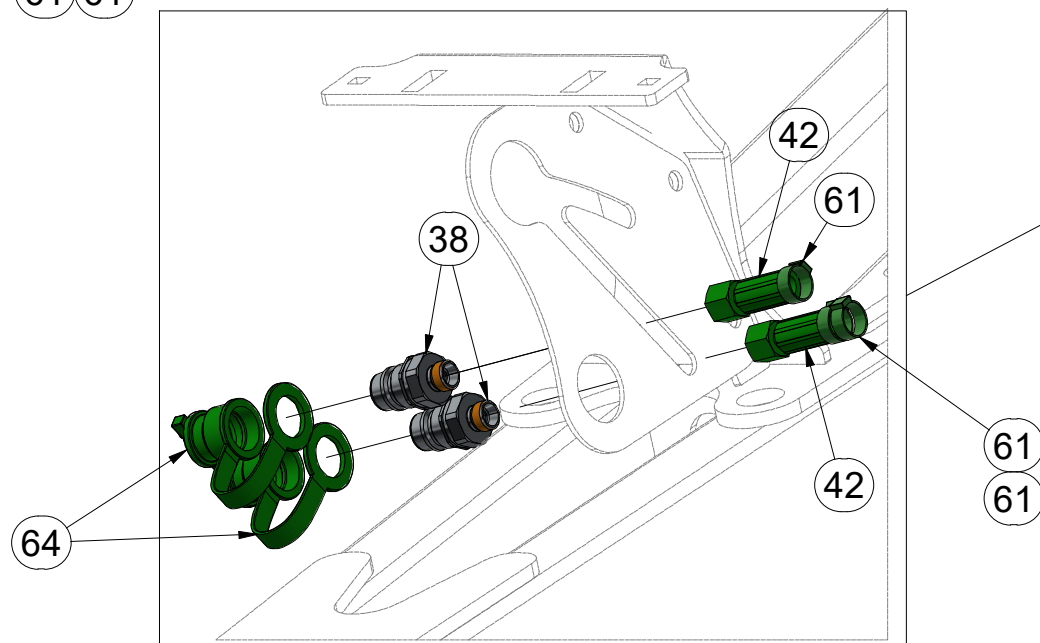
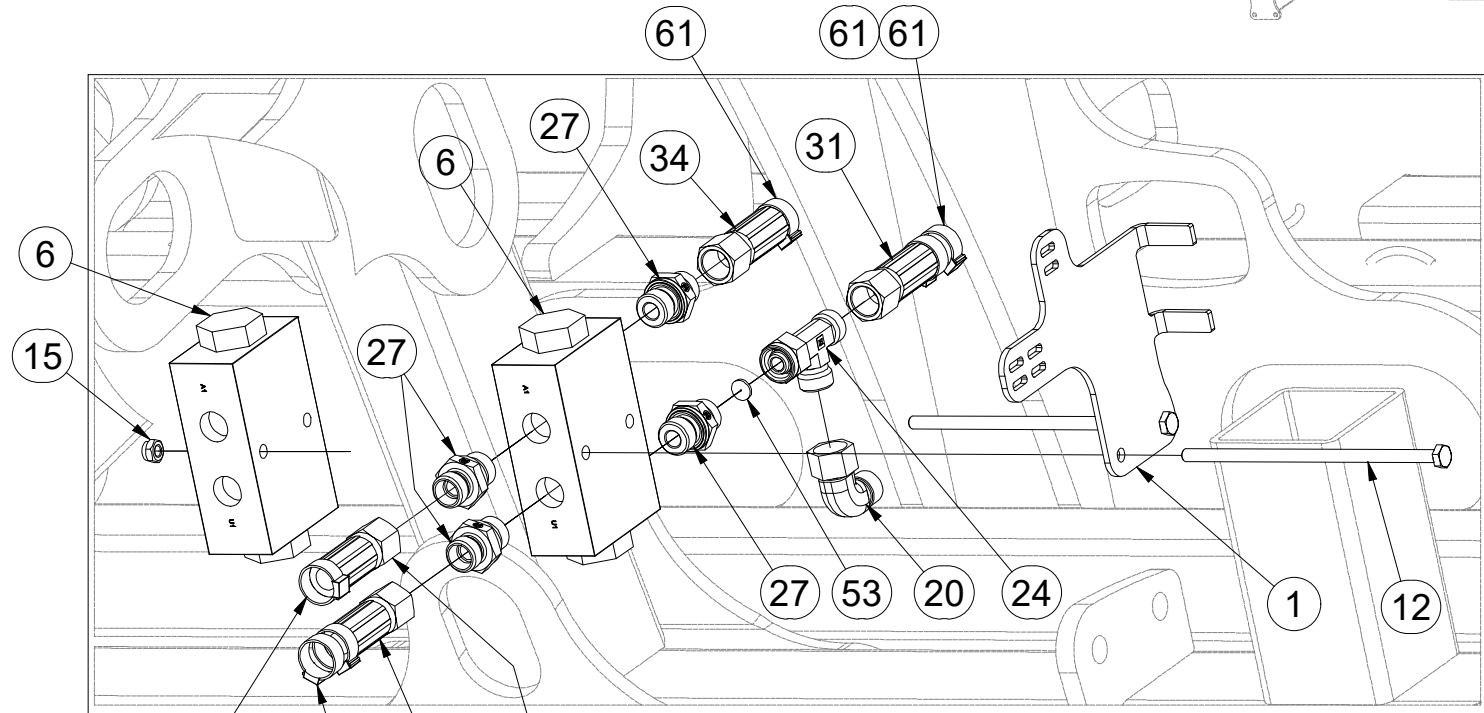
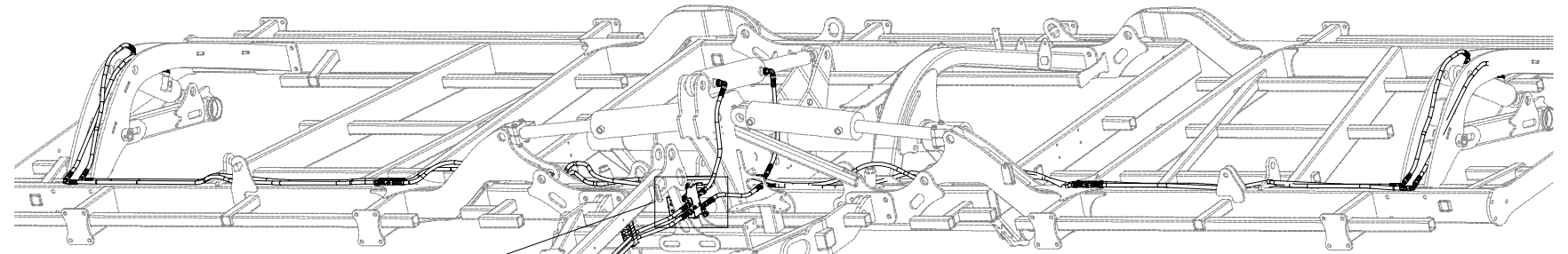

Pos.	Part Number	Pcs.
1	VZ00009054	1
6	m09911	2
12	m20263	2
15	m05560	2
20	m06803	13
24	m07568	1
27	m06528	8
31	m09627	1
34	m04761	1
38	m05210	3
42	m05216	6
53	m10782	2
61	m11282	21
62	m11294	12
64	m04098	2

ⒸZ HYDRAULIKA STROJE

Ⓓ HYDRAULIK DER MASCHINE

Ⓕ HYDRAULIQUE DE LA MACHINE

ⒸB MACHINE HYDRAULICS

ⒸR ГИДРАВЛИКА МАШИНЫ

ⒸL HYDRAULIKA MASZYN



VZ00012055

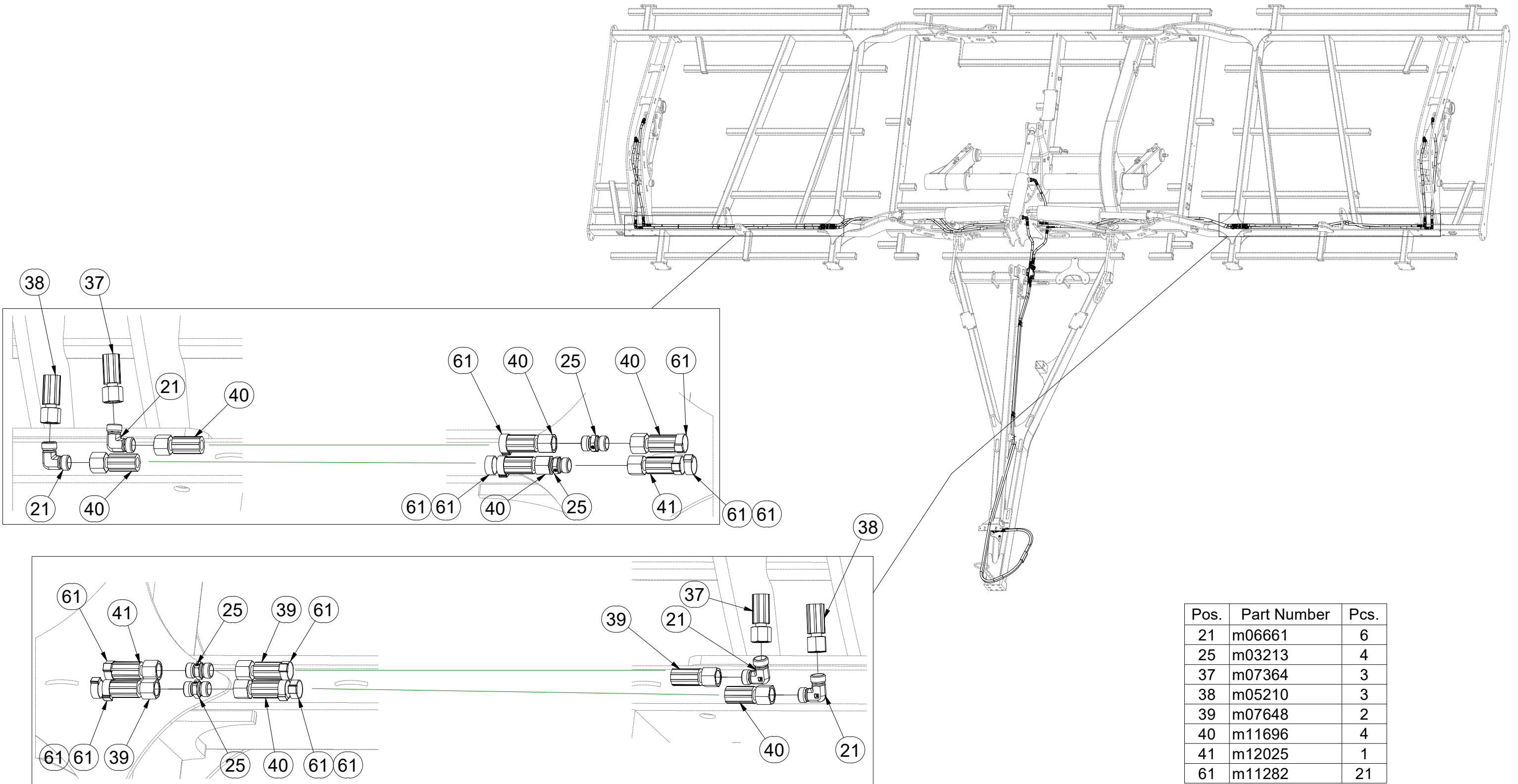

CZ HYDRAULIKA STROJE
 D HYDRAULIK DER MASCHINE
 F HYDRAULIQUE DE LA MACHINE

GB MACHINE HYDRAULICS
 RU ГИДРАВЛИКА МАШИНЫ
 PL HYDRAULIKA MASZYN



VZ00012055

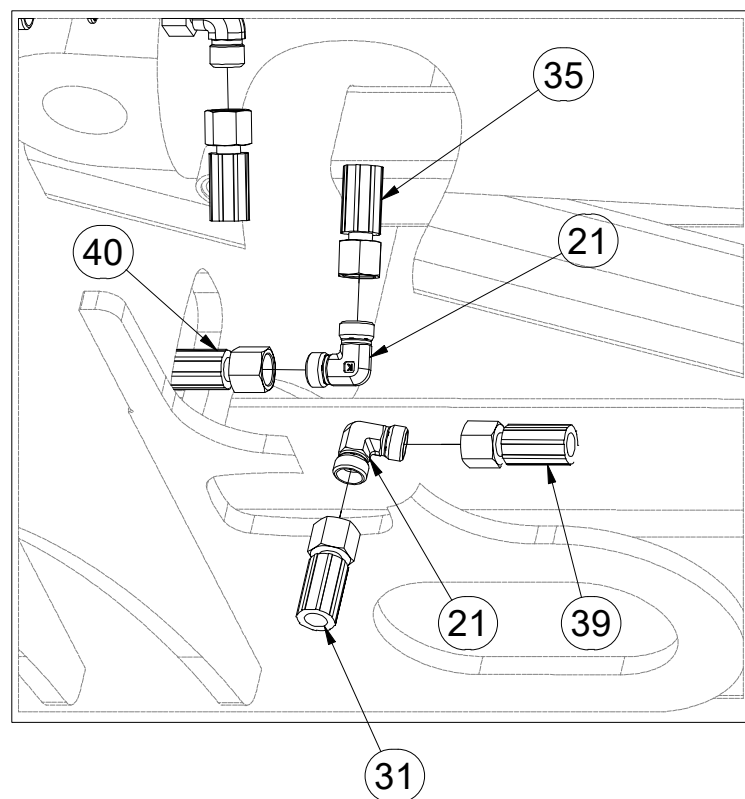
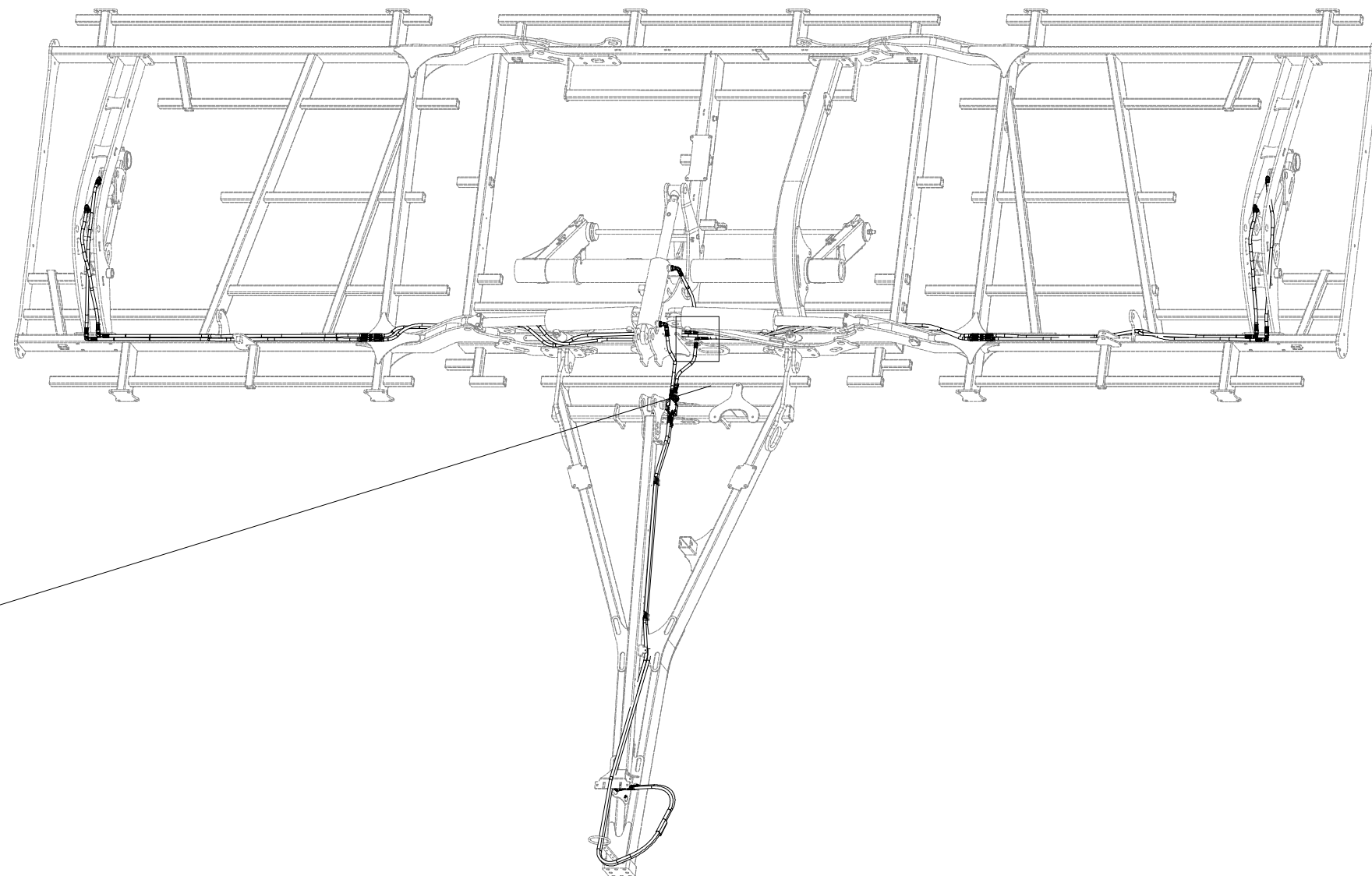

Pos.	Part Number	Pcs.
21	m06661	6
31	m09627	1
35	m09629	1
39	m07648	2
40	m11696	4

ⒸZ HYDRAULIKA STROJE

Ⓓ HYDRAULIK DER MASCHINE

Ⓕ HYDRAULIQUE DE LA MACHINE

ⒼB MACHINE HYDRAULICS

Ⓔ RU ГИДРАВЛИКА МАШИНЫ

Ⓕ PL HYDRAULIKA MASZYN



VZ00012055

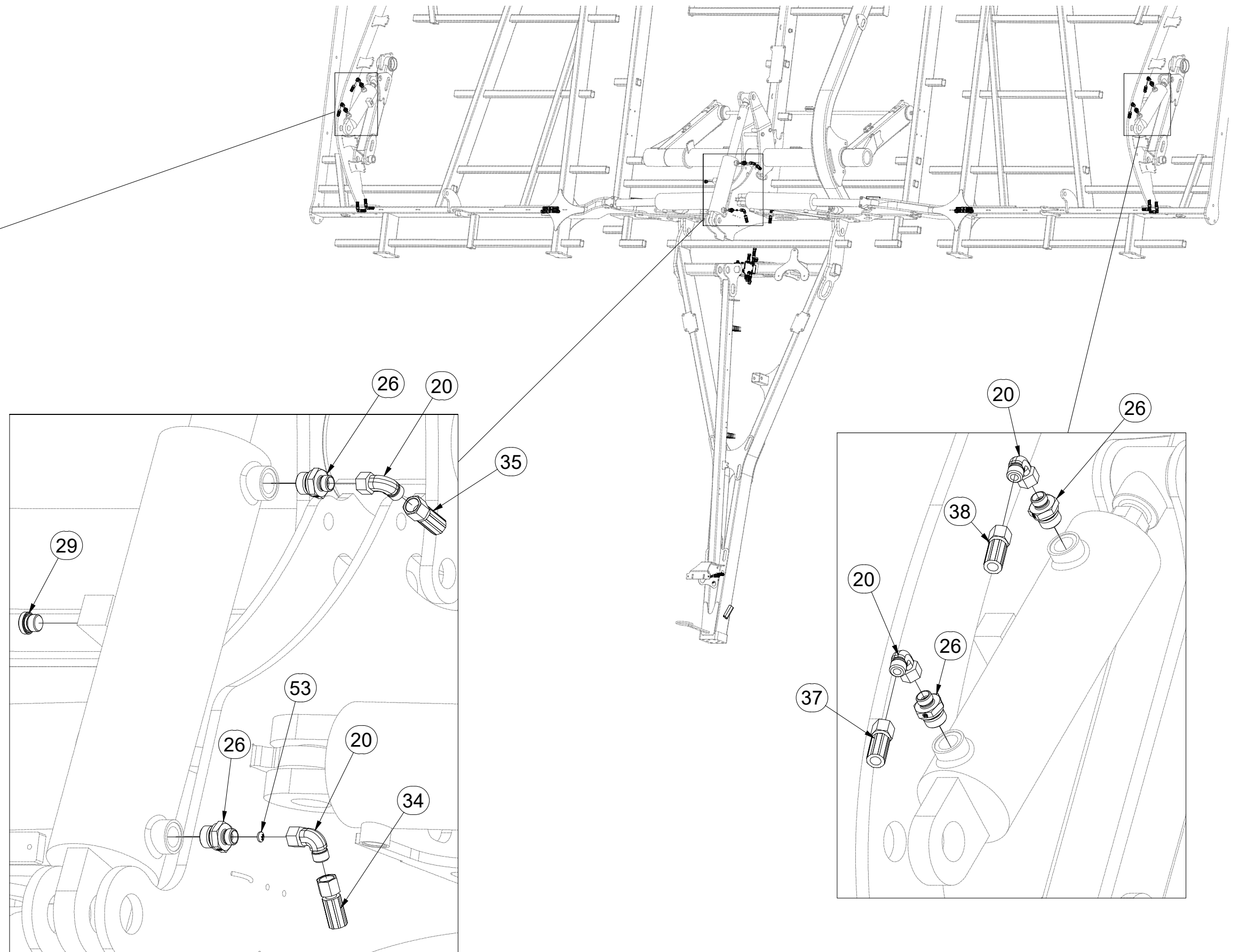
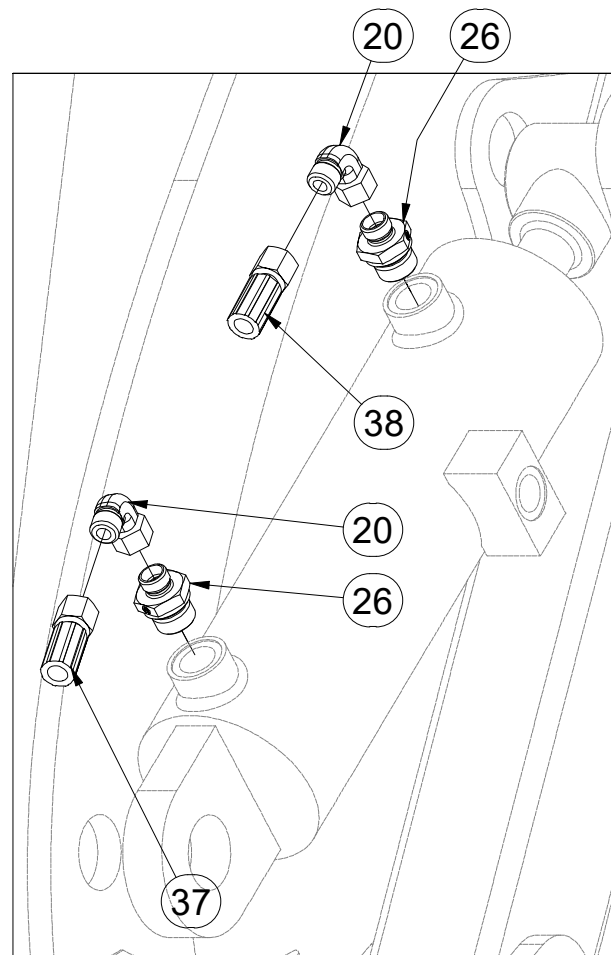

Pos.	Part Number	Pcs.
20	m06803	13
26	m09934	10
29	m06529	1
34	m04761	1
35	m09629	1
37	m07364	3
38	m05210	3
53	m10782	2

Ⓒ HYDRAULIKA STROJE
Ⓓ HYDRAULIK DER MASCHINE
Ⓕ HYDRAULIQUE DE LA MACHINE

Ⓖ MACHINE HYDRAULICS
Ⓡ ГИДРАВЛИКА МАШИНЫ
Ⓟ HYDRAULIKA MASZYN



VZ00012055

Pos.	Part Number	Pcs.
67	m11183	5

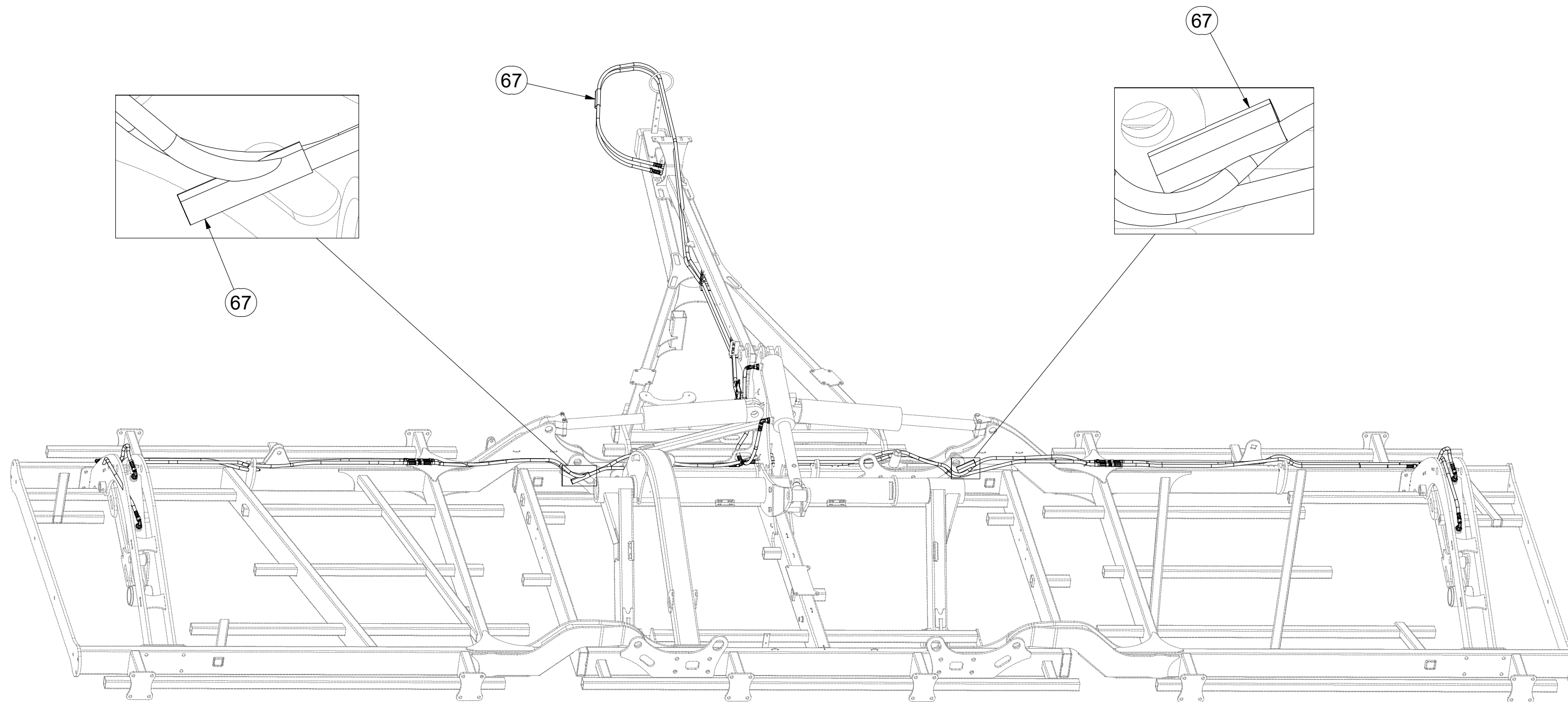

VZ00012055

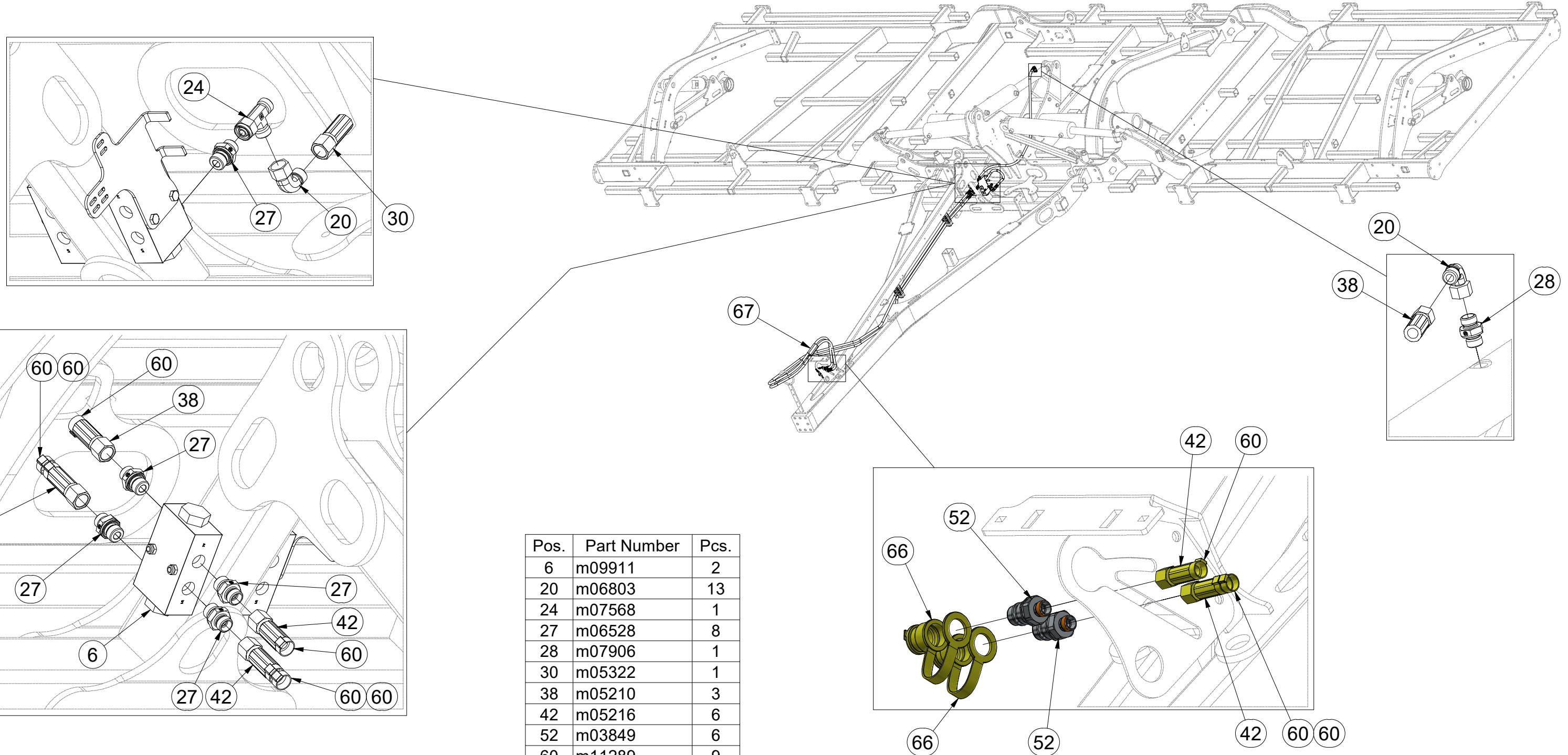

Pos.	Part Number	Pcs.
6	m09911	2
20	m06803	13
24	m07568	1
27	m06528	8
28	m07906	1
30	m05322	1
38	m05210	3
42	m05216	6
52	m03849	6
60	m11289	9
62	m11294	12
66	m04023	2
67	m11183	5

ⒸZ HYDRAULIKA STROJE

ⒸD HYDRAULIK DER MASCHINE

ⒸF HYDRAULIQUE DE LA MACHINE

ⒸB MACHINE HYDRAULICS

ⒸRU ГИДРАВЛИКА МАШИНЫ

ⒸPL HYDRAULIKA MASZYNY



VZ00012055

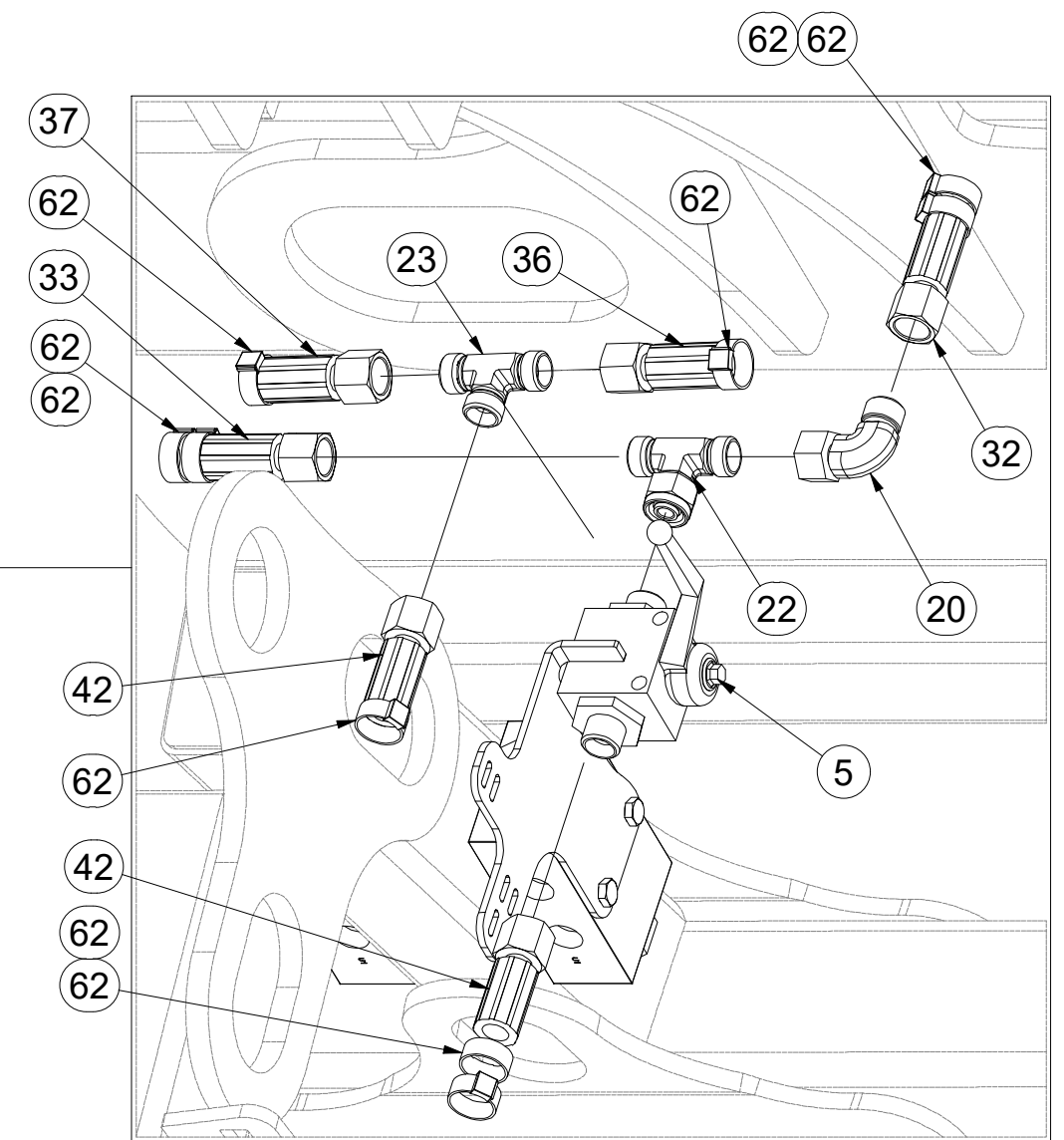
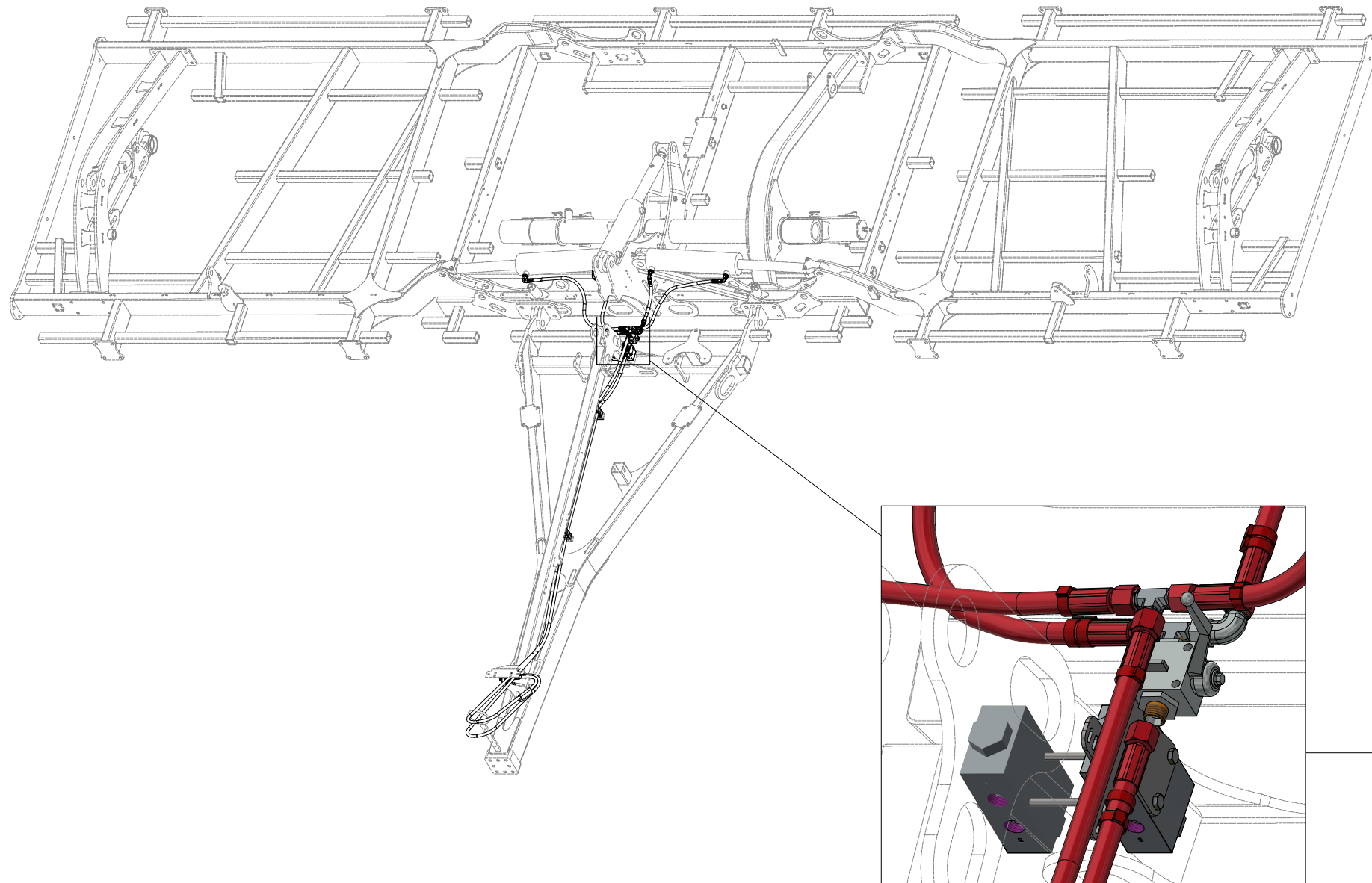

Pos.	Part Number	Pcs.	Pos.	Part Number	Pcs.
5	m04623	1	36	m04033	1
20	m06803	13	37	m07364	3
22	m07567	1	42	m05216	6
23	m03889	1	61	m11282	21
32	m17441	1	62	m11294	12
33	m09628	1			

Ⓒ HYDRAULIKA STROJE

Ⓓ HYDRAULIK DER MASCHINE

Ⓕ HYDRAULIQUE DE LA MACHINE

Ⓖ MACHINE HYDRAULICS

Ⓡ ГИДРАВЛИКА МАШИНЫ

Ⓟ HYDRAULIKA MASZYNY



VZ00012055

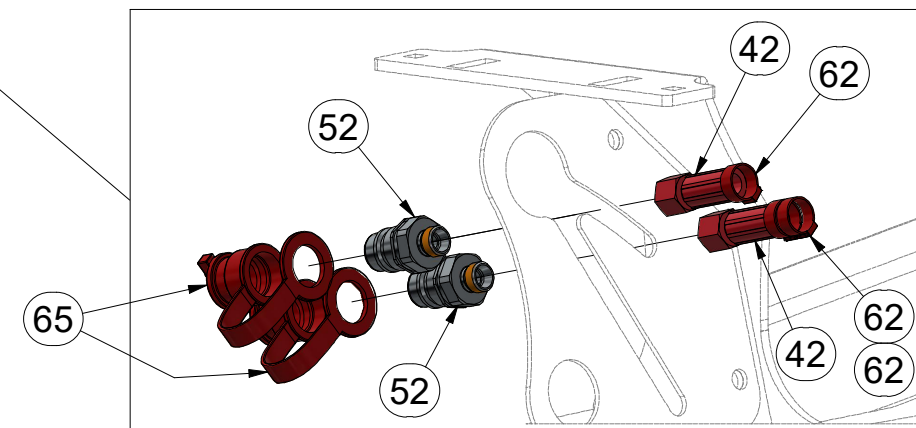
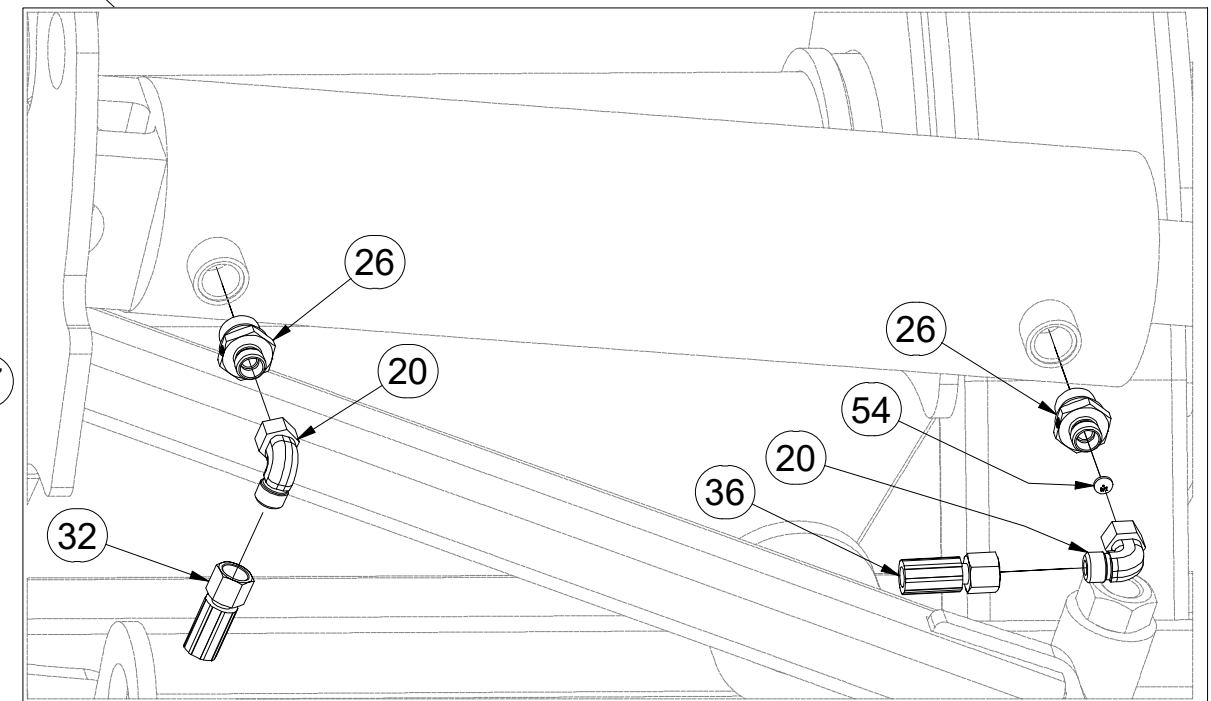
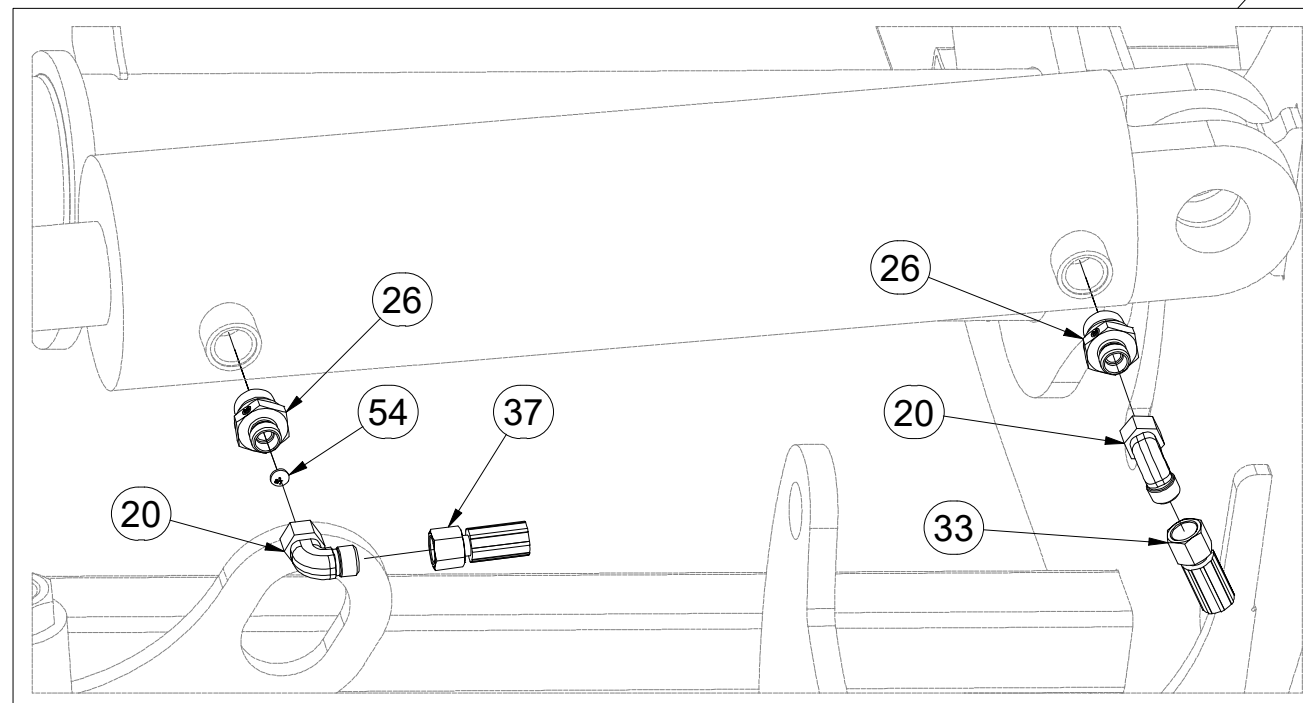
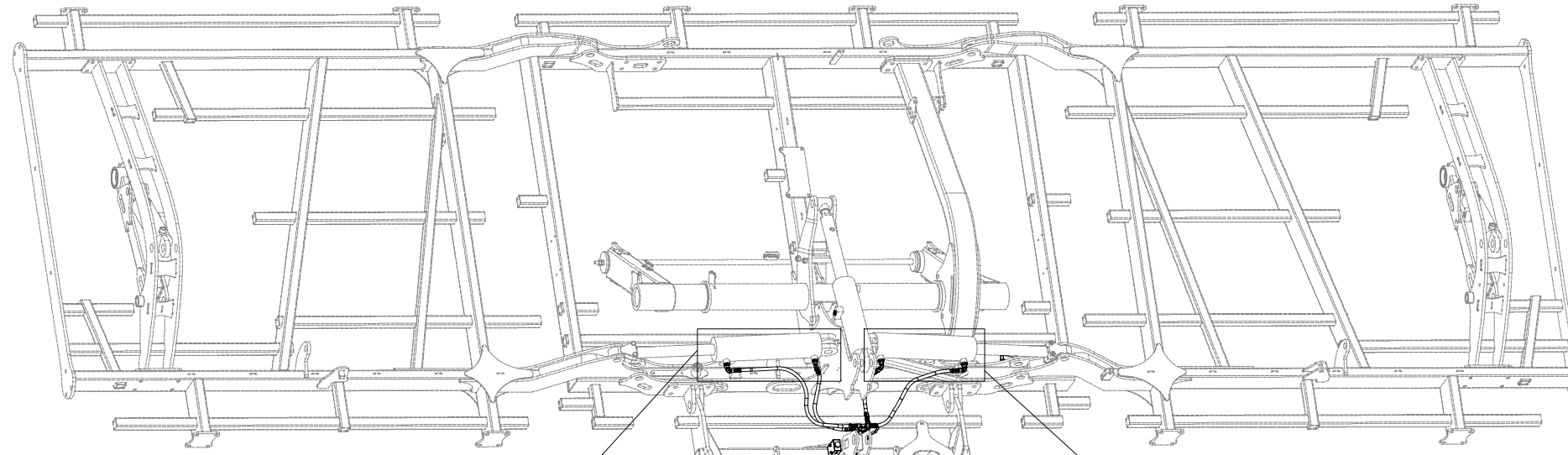

Pos.	Part Number	Pcs.	Pos.	Part Number	Pcs.
20	m06803	13	42	m05216	6
26	m09934	10	52	m03849	6
32	m17441	1	54	m10780	2
33	m09628	1	62	m11294	12
36	m04033	1	65	m04022	2
37	m07364	3			

ⒸZ SOUPRAVA TĚSNIVA PÍSTNIC

Ⓓ KOLBENSTANGENDICHTUNGSMITTELSATZ

Ⓕ SET DE GARNITURE DES TIGES DE PISTON

ⒼB SEALING SET FOR PISTON RODS

ⒺU КОМПЛЕКТ ПРОКЛАДОК ЦИЛИНДРОВ

ⒼL ZESTAW USZCZELEK TRZPIENIA TŁOKA

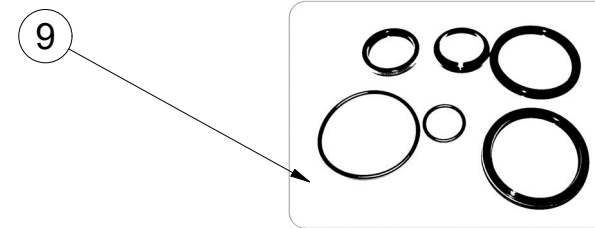
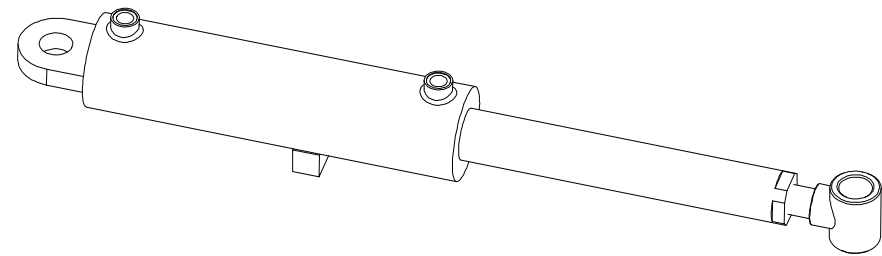

m13432 - Ø100/Ø63-273		
Pos	Part number	Pcs
1	m15698	1

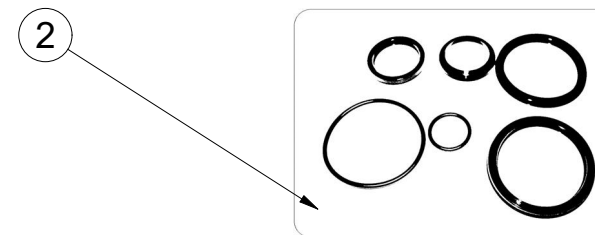
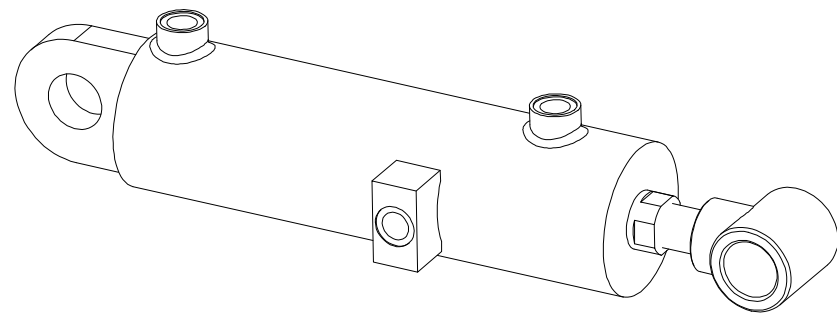

m13433 - Ø90/Ø40-203		
Pos	Part number	Pcs
2	m15699	1

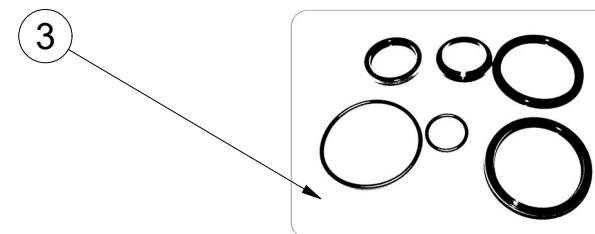
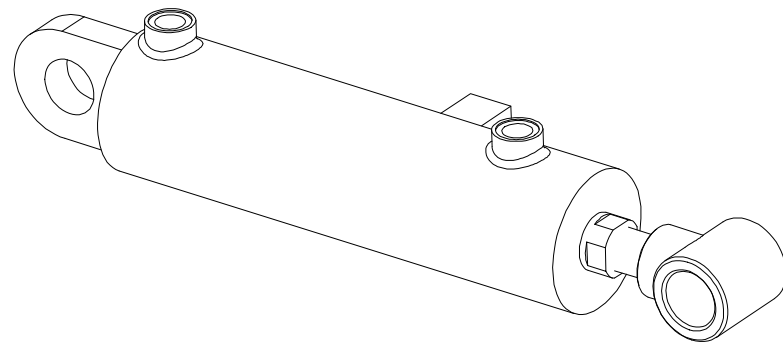

m13434 - Ø80/Ø40-26		
Pos	Part number	Pcs
3	m15701	1

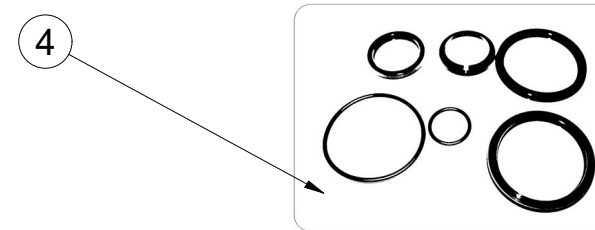
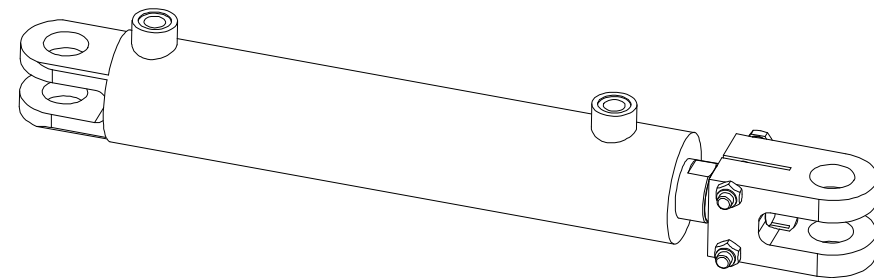

m14371 - Ø63/Ø40-270		
Pos	Part number	Pcs
4	m15070	3

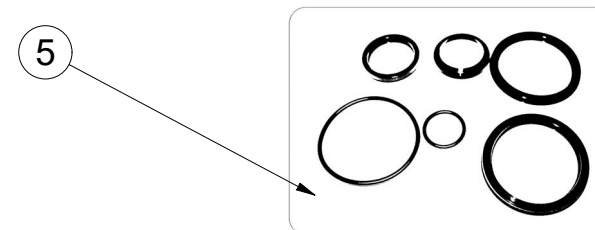
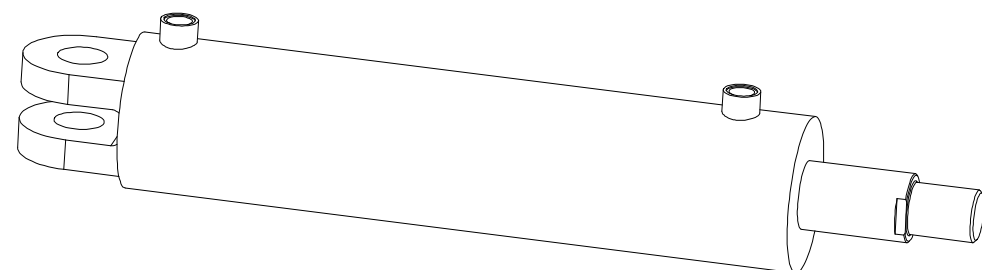

m14384 - Ø110/Ø50-390		
Pos	Part number	Pcs
5	m15697	2

Ⓒ SAMOLEPKY STROJE

Ⓓ AUFKLEBER MASCHINEN

Ⓕ VOITURE MACHINES

Ⓖ STICKERS MACHINES

Ⓡ СТИКЕРЫ МАШИНЫ

Ⓟ NAKLEJKI MASZYNY



m21231

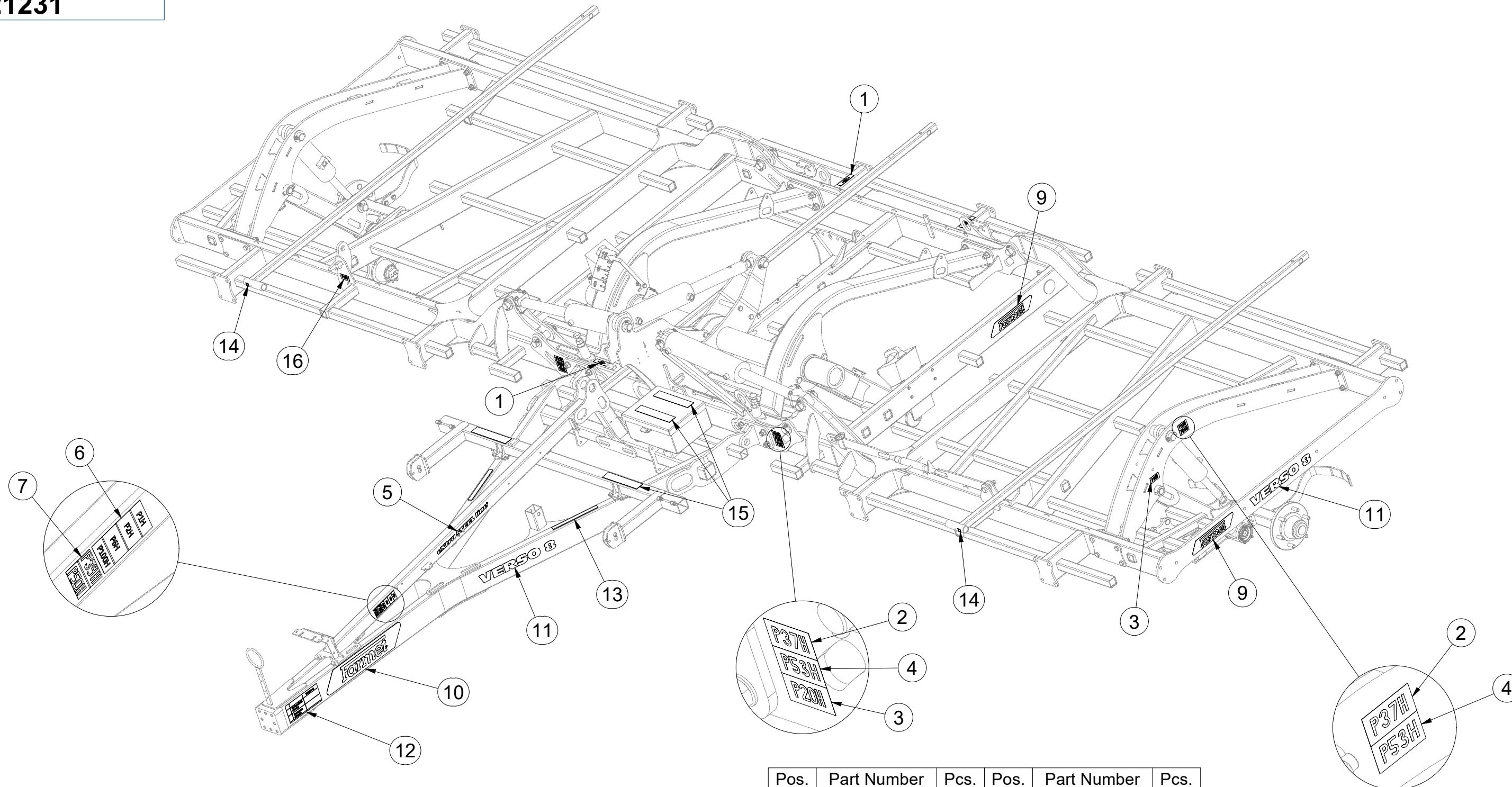

Pos.	Part Number	Pcs.	Pos.	Part Number	Pcs.
1	m03316	4	10	m14002	2
2	m04365	6	11	m14003	4
3	m04368	6	12	m13632	1
4	m04369	6	13	m14146	2
5	m10353	2	14	m03320	10
6	m11295	1	15	m11147	4
7	m11296	1	16	m04363	1
9	m13117	4			

Ⓒ SAMOLEPKY STROJE

Ⓓ AUFKLEBER MASCHINEN

Ⓕ VOITURE MACHINES

Ⓖ STICKERS MACHINES

Ⓡ СТИКЕРЫ МАШИНЫ

Ⓟ NAKLEJKI MASZYNY



m21231

Pos.	Part Number	Pcs.	Pos.	Part Number	Pcs.
1	m03316	4	9	m13117	4
2	m04365	6	10	m14002	2
3	m04368	6	11	m14003	4
4	m04369	6	14	m03320	10
5	m10353	2	15	m11147	4
8	m13116	2			

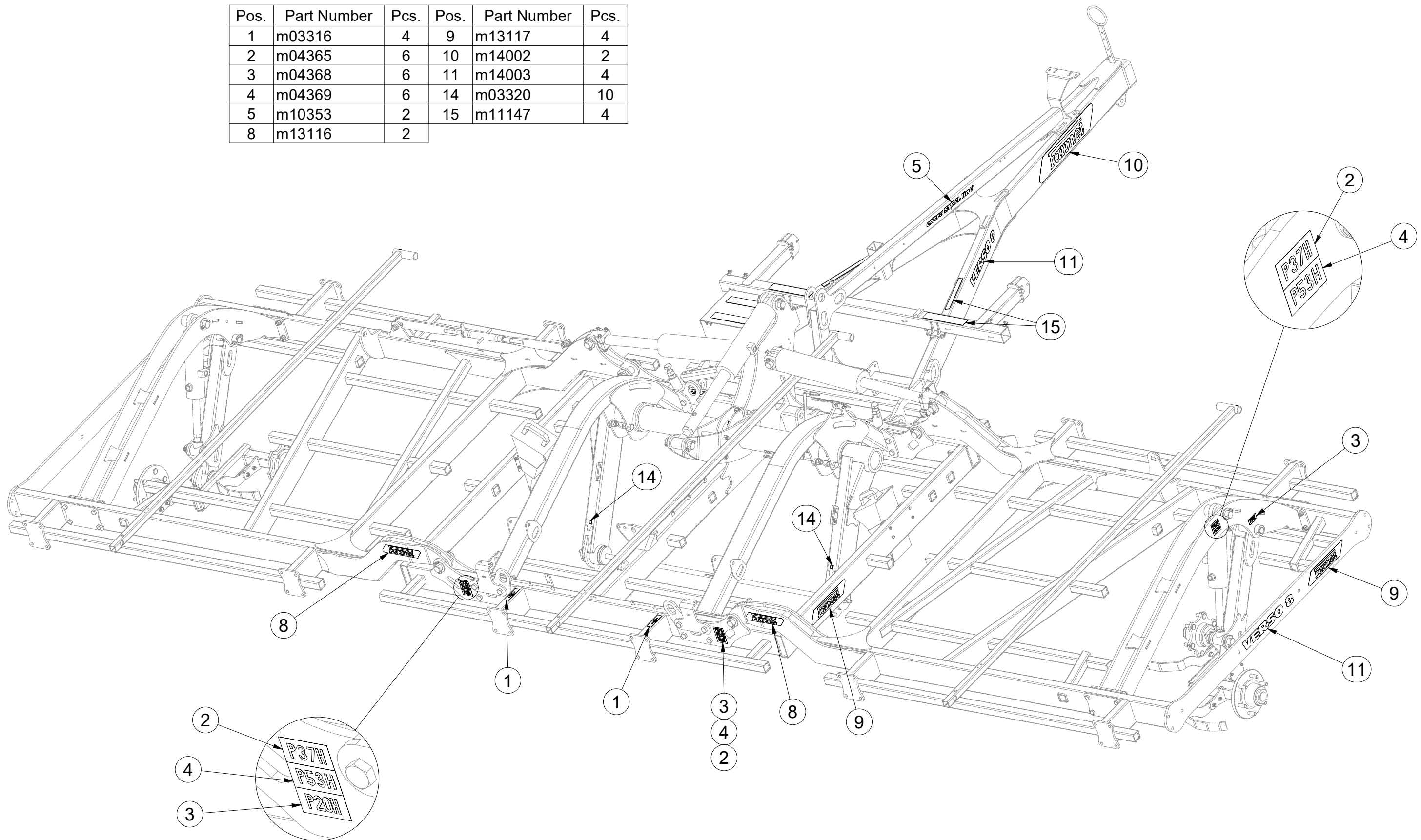

Ⓒ SVĚTELNÁ SADA

Ⓓ LEUCHTENSATZ

Ⓕ KIT LUMINEUX

VZ00012659

Ⓖ LIGHTING SET

Ⓡ ОСВЕТИТЕЛЬНЫЙ КОМПЛЕКТ

Ⓢ ZESTAW OŚWIETLENIA

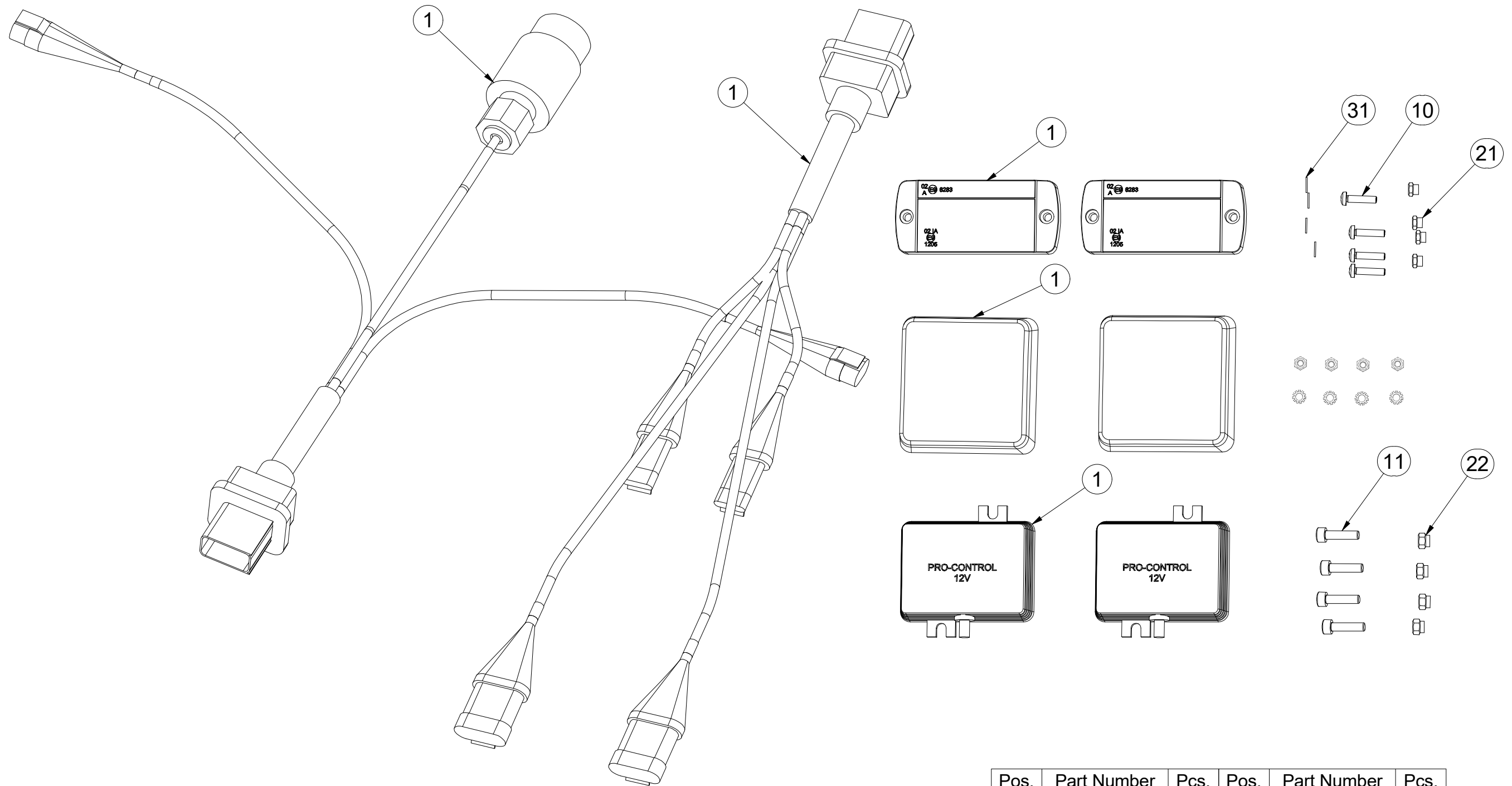

Pos.	Part Number	Pcs.	Pos.	Part Number	Pcs.
1	m21220	1	21	m05562	4
10	m15790	4	22	m06236	4
11	m10591	4	31	m05597	4

Ⓒ SVĚTELNÁ SADA

Ⓓ LEUCHTENSATZ

Ⓕ KIT LUMINEUX

VZ00012659

Ⓖ LIGHTING SET

Ⓡ ОСВЕТИТЕЛЬНЫЙ КОМПЛЕКТ

Ⓢ ZESTAW OŚWIETLENIA

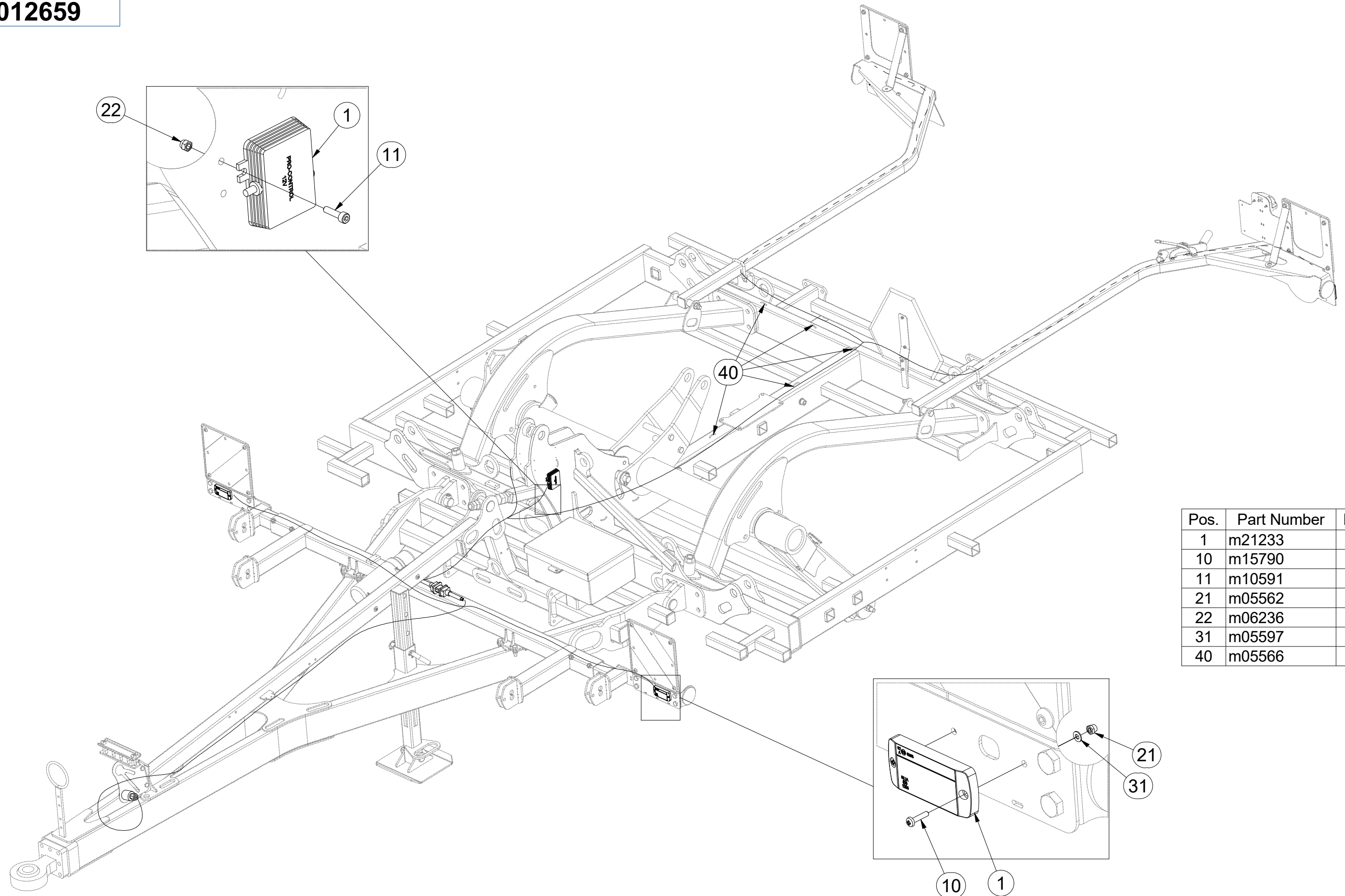

Pos.	Part Number	Pcs.
1	m21233	1
10	m15790	4
11	m10591	4
21	m05562	4
22	m06236	4
31	m05597	4
40	m05566	30

Ⓒ SVĚTELNÁ SADA

Ⓓ LEUCHTENSATZ

Ⓕ KIT LUMINEUX

VZ00012659

Ⓖ LIGHTING SET

Ⓡ ОСВЕТИТЕЛЬНЫЙ КОМПЛЕКТ

Ⓟ ZESTAW OŚWIETLENIA

Farmet

Pos.	Part Number	Pcs.
1	m21233	1
40	m05566	30

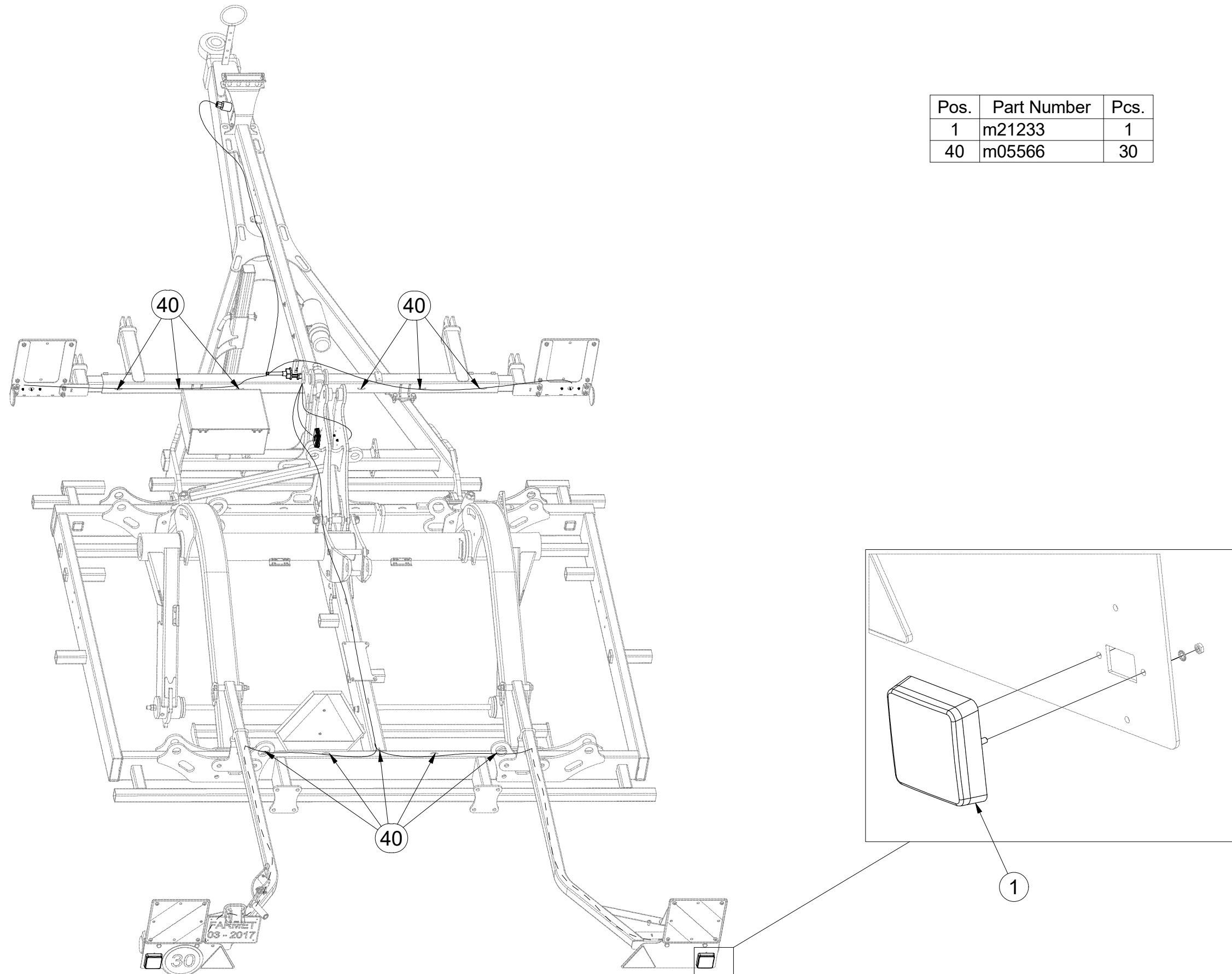

Ⓒ SVĚTELNÁ SADA

Ⓓ LEUCHTENSATZ

Ⓕ KIT LUMINEUX

m21233

Ⓖ LIGHTING SET

Ⓡ ОСВЕТИТЕЛЬНЫЙ КОМПЛЕКТ

Ⓟ ZESTAW OŚWIETLENIA

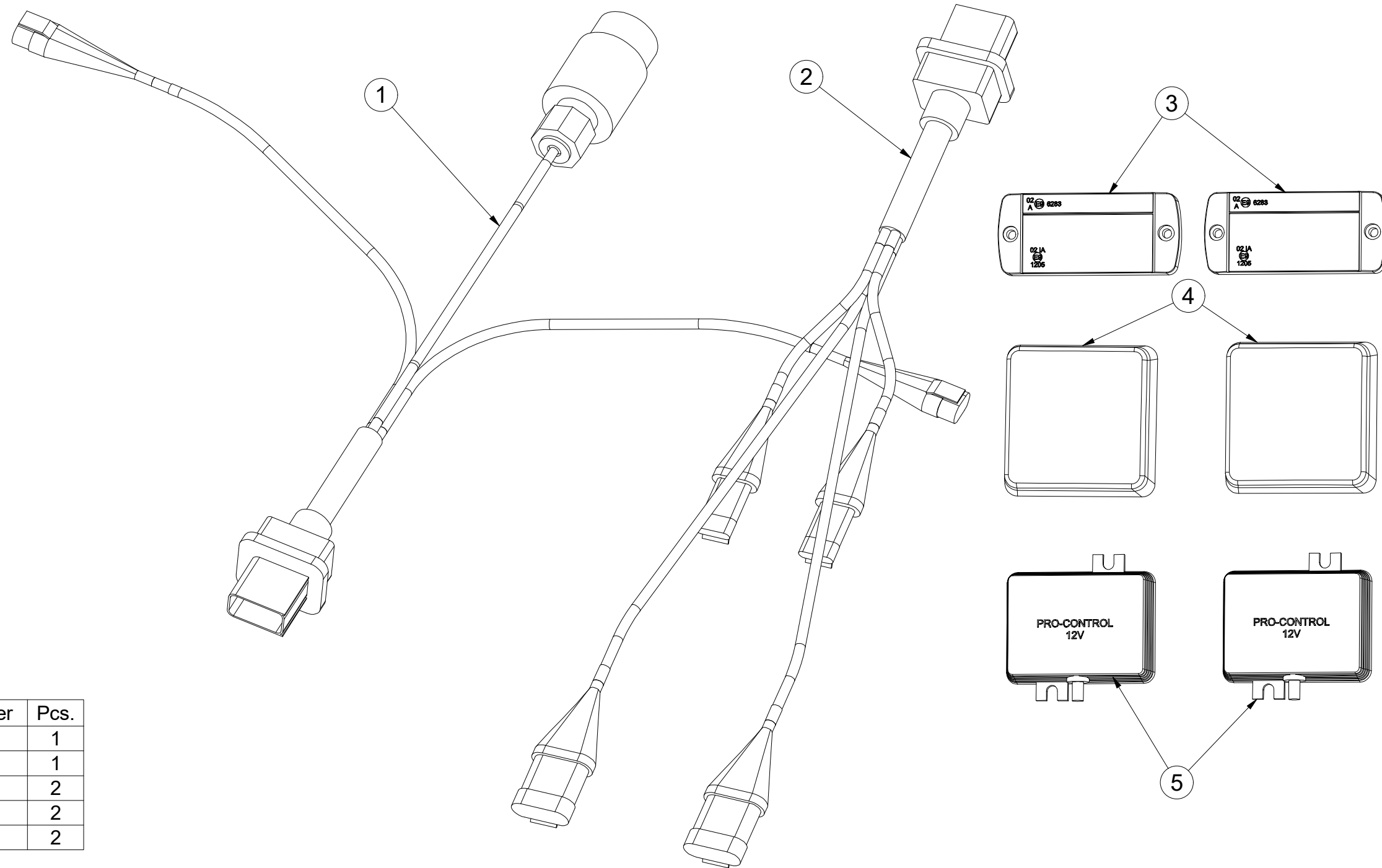

Pos.	Part Number	Pcs.
1	m14779	1
2	m14778	1
3	m14776	2
4	m19044	2
5	m14777	2

- Ⓒ UTAHOVACÍ MOMENTY ŠROUBŮ
 Ⓓ ANZUGMOMENTE VON SCHRAUBEN
 Ⓕ COUPLES DE SERRAGE DES VIS

- Ⓒ SCREW TIGHTENING TORQUE
 Ⓓ МОМЕНТЫ ЗАЖАТИЯ БОЛТОВ
 Ⓕ MOMENTY DOKRĘCANIA ŚRUB



P		5.8	8.8	10.9	12.9	Z	
D	R	Mu	Mu	Mu	Mu	DIN 7991	ISO 10642
mm	mm	Nm	Nm	Nm	Nm	Nm	Nm
M6	1	6	9	13	15	7,2	7,9
M8	1,25	14	22	32	38	17	19
M10	1,5	29	44	64	75	35	38
M12	1,75	49	76	111	130	58	65
M14	2	79	120	176	206	93	100
M16	2	123	188	276	323	144	158
M18	2,5	169	257	378	443	-	220
M20	2,5	239	365	536	628	-	310
M22	2,5	329	529	738	864	-	420
M24	3	413	629	924	1082	-	530
M27	3	613	934	1372	1606	-	-
M30	3,5	832	1267	1862	2179	-	-
M33	3,5	1130	1723	2530	2961	-	-
M36	4	1451	2210	3246	3799	-	-
M39	4	1885	2872	4217	4936	-	-
M42	4,5	2322	3538	5196	6080	-	-
M45	4,5	2909	4433	6511	7619	-	-
M48	5	3513	535	7862	9200	-	-
M52	5	4524	6895	10123	11849	-	-
M56	5,5	5636	8589	12614	14761	-	-

- Mu - Ⓒ UTAHOVACÍ MOMENT
 Ⓓ ANZUGMOMENTE
 Ⓕ COUPLE DE SERRAGE
 Ⓒ TIGHTENING TORQUE
 Ⓓ МОМЕНТ ЗАЖАТИЯ
 Ⓕ MOMENT DOKRĘCANIA
- D - Ⓒ JMENOVITÝ PRŮMĚR
 Ⓓ NENNDURCHMESSER
 Ⓕ DIAMETRE NOMINAL
 Ⓒ NOMINAL DIAMETER
 Ⓓ НОМИНАЛЬНЫЙ ДИАМЕТР
 Ⓕ ŚREDNICA NOMINALNA
- R - Ⓒ ROZTEČ ZÁVITU - STOUPÁNÍ
 Ⓓ GEWINDESTEIGUNG
 Ⓕ PAS DE FILET - PAS
 Ⓒ SCREW PITCH – LEAD
 Ⓓ ШАГ РЕЗЬБЫ
 Ⓕ ROZSTAW GWINTU - SKOKI
- P - Ⓒ PEVNOST
 Ⓓ FESTIGKEIT
 Ⓕ RÉSISTANCE
 Ⓒ STRENGTH
 Ⓓ ПРОЧНОСТЬ
 Ⓕ WYTRZYMA OŚĆ
- Z - Ⓒ ZÁPUSTNÉ ŠROUBY
 Ⓓ SENKKOPFSCHRAUBEN
 Ⓕ VIS A TETE FRAISEE
 Ⓒ COUNTERSUNK SCREWS
 Ⓓ БОЛТЫ С УТОПЛЕННОЙ ГОЛОВКОЙ
 Ⓕ ŚRUBY Z ŁBEM STOŻKOWYM PŁASKIM

- Ⓒ Hodnoty momentů jsou poníženy o -10% oproti tabulkovým hodnotám. Šroubové spoje utahujte dle vyznačeného utahovacího momentu v dokumentaci. Pokud není utahovací moment v dokumentaci vyznačen, utahujte dle obecné tabulky. Pokud je v dokumentaci definován spoj šroubu a matice o různých pevnostech, vždy utahujte na moment komponenty nižší.
- Ⓓ Die Werte der Anzugsmomente sind um 10 % gegenüber den Tabellenwerten verringert. Ziehen Sie die Schraubverbindungen gemäß dem in der Dokumentation festgeschrieben Anzugsmoment an. Sofern das Anzugsmoment nicht in der Dokumentation aufgeführt ist, ziehen Sie sie gemäß der allgemeinen Tabelle an. Wenn in der Dokumentation eine Verbindung von Schraube und Mutter mit verschiedene Festigkeiten definiert ist, wird immer mit dem Moment des Bauteils mit der geringeren Festigkeit angezogen.
- Ⓕ Les valeurs des couples de serrage sont baissées de 10% par rapport aux valeurs de tableau. Serrez les raccords à vis selon le couple de serrage indiqué dans les documents. Si le couple de serrage n'est pas indiqué dans les documents, serrez selon le tableau général. Si les documents définissent un assemblage par boulon de diverses résistances, serrez toujours au moment de la composante avec résistance inférieure.
- Ⓒ The torque values are reduced by 10% compared to the table values. Tighten the screw joints according to the tightening torque stated in the documentation. If the tightening torque is not stated in the documentation, tighten according to the general table. If there is a joint with a screw and a nut at different strengths in the documentation, always tighten to the torque of the component with lower strength.
- Ⓓ Значения моментов затяжки уменьшены на 10% по сравнению с данными в таблице. Резьбовые соединения зажимайте с установленным в документации моментом зажатия. Если в документации не указан момент зажатия, то зажимайте по действующей в общем таблице. Если в документации установлено соединение из болта и гайки различной прочности, всегда зажимайте с моментом для компонента с меньшей прочностью.
- Ⓕ Wartości momentów dokręcania są obniżone o 10% w stosunku do wartości z tabeli. Połączenia śrubowe należy dokręcać zgodnie z momentem obrotowym w dokumentacji. Jeśli w dokumentacji nie ma podanego momentu obrotowego, należy dokręcać zgodnie z ogólną tabelą. Jeśli w dokumentacji zdefiniowane jest połączenie ze śrubą nakrętką różnych wytrzymałościach, zawsze należy dokręcać zachowując moment dokręcania komponentu z niższą wytrzymałością.

- Ⓒ UTAHOVACÍ MOMENTY ŠROUBŮ
 Ⓓ ANZUGMOMENTE VON SCHRAUBEN
 Ⓕ COUPLES DE SERRAGE DES VIS

- Ⓖ SCREW TIGHTENING TORQUE
 Ⓡ МОМЕНТЫ ЗАЖАТИЯ БОЛТОВ
 Ⓟ MOMENTY DOKRĘCANIA ŚRUB



- Ⓒ **OBECNÝ PŘEDPIS UTAHOVÁNÍ ZAJIŠTĚNÍ ČEPOVÝCH SPOJŮ:**
 Ⓓ **ALLGEMEINE VORSCHRIFT FÜR DAS ANZIEHEN VON BOLZENVERBINDUNGEN:**
 Ⓕ **CONSIGNE GENERALE POUR LE SERRAGE DES ARTICULATIONS CYLINDRIQUES:**
 Ⓖ **GENERAL INSTRUCTION FOR TIGHTENING THE SECURING OF PIN JOINTS:**
 Ⓡ **ОБЩЕЕ ОПИСАНИЕ ЗАЖАТИЯ ПРЕДОХРАНЕНИЯ СОЕДИНЕНИЙ ПАЛЬЦАМИ:**
 Ⓟ **OGÓLNE ZASADY DOKRĘCANIA ZABEZPIECZENIA POŁĄCZEŃ CZOPEM:**



X

M8, M10, M12

M14

M

09-15Nm

15-25Nm

- X - Ⓒ ROZMĚR ŠROUBU
 Ⓓ SCHRAUBENGRÖSSE
 Ⓕ DIMENSIONS DE LA VIS

- Ⓖ BOLT DIMENSION
 Ⓡ РАЗМЕР БОЛТА
 Ⓟ ROZMIAR ŚRUBY

- M - Ⓒ ORIENTAČNÍ MOMENT
 Ⓓ ANZUGSMOMENT
 Ⓕ COUPLE D'ORIENTATION

- Ⓖ ORIENTATION TORQUE
 Ⓡ ОРИЕНТАЦИОННЫЙ МОМЕНТ
 Ⓟ ORIENTACYJNY MOMENT

- Ⓒ Tyto spoje není nutné ověřovat kontrolou momentovým klíčem = stačí vizuálně kontrolovat sešroubování.
 Ⓓ Diese Verbindungen müssen nicht mit einem Drehmomentschlüssel überprüft werden = es genügt, die Verschraubung visuell zu kontrollieren.
 Ⓕ Il n'est pas nécessaire de contrôler le serrage à l'aide d'une clé dynamométrique = un contrôle visuel de l'assemblage suffit.
 Ⓖ These joints do not have to be verified by checking with a torque wrench = visual inspection of bolting is sufficient.
 Ⓡ Эти соединения не нужно контролировать динамометрическим ключом = достаточно визуально проверять прикручивание.
 Ⓟ Nie trzeba sprawdzać tych połączeń kluczem dynamometrycznym = wystarczy wizualnie skontrolować dokręcenie.