



....Immediate sealing effect

CATALOGUE 2019

Vrbovec 321, 671 24 Vrbovec, Czech Republic

Email: info@aditeg.cz

Telephone / fax: +420 515 320 023 / +420 515 320 024

www.aditeg.cz

TABLE OF CONTENTS

ABOUT US

p. 3

ELASTOMER PROPERTIES

p. 8

SHEETS

p. 11

RUBBER SHEETS

-material SBR	p. 12
-material NBR	p. 14
-material EPDM	p. 16
-material CR	p. 17
-material FPM	p. 19
-silicone material	p. 19
-material NR	p. 19
-material PU	p. 19
-foam material	p. 20
-regranulate material	p. 29

FLOOR SHEETS

-rubber material	p. 45
-material PVC	p. 47
-plastic material	p. 48

RUBBER MATS

-front door mats	p. 52
-mats	p. 55
-Anti-Slip mats – PVC material	p. 57
-Anti-Slip bath mat	p. 58

RUBBER STABLE MATS	p. 59
--------------------------	-------

NON-ASBESTOS RUBBER GASKET ADISEAL	p. 61
--	-------

CONVEYOR BELTS

p. 62

PTFE- TEFLON SHEETS/ TEFLON RODS/ TEFLON TAPES

p. 64

-sheets	p. 64
-rods	p. 64
-tapes	p. 65

SILENTBLOCKS

p. 66

- TYP A	p. 67
- TYP B	p. 68
- TYP C	p. 69
- TYP D	p. 70
- TYP E	p. 71

SEALING CORDS

p. 72

-silicone material	p. 73
-material FPM	p. 73
-material EPDM	p. 73
-material NRB	p. 74
-foam EPDM material	p. 74

HOSES

p. 75

-water hose	p. 76
-textile hose	p. 77
-spiral reinforced PVC suction hose	p. 78
-PVC Steel Wire Reinforced Hose	p. 79
-single layer hoses	p. 80
-silicone hoses	p. 82

PLOW BLADES

p. 83

HANGING PVC STRIPS

p. 84

JACK PADS

p. 85

HYDRAULIC SEALS

p. 86

-scraper seals	p. 87
-rod seals	p. 88
-wear rings	p. 89
-piston seals	p. 90
-static seals	p. 91
-radial shaft seals	p. 92
-back -up rings	p. 93

WATER SEAL

p. 94

DIE-CUT PRODUCTS

p. 96

MOLDED PRODUCTS

p. 97

O-RINGS

p. 98

PROFILES

p. 99

-silicone – square - rectangular	p. 100
-buffer	p. 102
-P	p. 103
-facade	p. 109
-joint cover	p. 113
-H	p. 117
-D	p. 119
-edge protecting	p. 128
-wedge	p. 132
-clamping	p. 134
-crown	p. 137
-protective/gate	p. 139
-cords	p. 143
-C	p. 144
-hoses	p. 146
-U special	p. 147
-U	p. 148
-square	p. 165
-L	p. 168
-doorframe	p. 172

ADITEG s.r.o.

RUBBER PRODUCTS

....Immediate sealing effect



www.aditeg.cz

Aditeg Ltd. was founded in 2003, which was represented only by offices back then. We started vigorously, confidently and successfully, so after three years in the market we moved to Vrbovec, where we built a production, a warehouse and a distribution center. After a successful operation in the market, we found out that the production, storage and distribution center had to be further expanded and in 2014 we were again forced to relocate to the new premises, where we built additional offices, production, warehouse and distribution center. In 2017, we again expanded into 2 production and storage premises due to capacity reasons.

We gradually acquired machines with the latest production technologies in the new halls, and thus we started to expand our production possibilities.

Our machinery includes:

- 6 CNC plotters
- 2 CNC table milling machines
- 1 CNC lathe
- 3 automatic bridge presses
- 2 smaller classic cutting presses
- 1 Kiss Cut
- 2 belt cutters
- 1 laminating machine
- 1 Bäumler splitting machine
- 2 injection molding machines
- 1 extruder profiles

As a result, we can offer you better prices and respond more precisely to your requirements

In our selection you will find rubber products from the series:

- sheets
- silentblocks
- profiles
- O-rings
- flat rings
- molded products
- die-cut products and others

You can choose our goods from:

- PRODUCT CATALOGUE - its structure was designed to be clear and the selection aims to be as comfortable as possible
- E-SHOP - which is a part of our website (www.aditeg.cz)

Wide offer of goods in stock, very short delivery time or custom production are all attributes of Aditeg s.r.o. services.

Our satisfied customers include clients both on the Czech market and worldwide.

We have obtained ISO 9001: 2016 and 14001: 2016 certification of recognized quality seal. Our products meet dimensional and quality tolerances of the relevant standards. We emphasize the balance between quality and price, individual approach to customers, customization of production according to your requirements and timely delivery. These are all the advantages that ensure more and more satisfied customers.

You will certainly appreciate the family environment of our company and our efforts to do our best. We believe that our goods will be interesting and useful both for you and your clients and customers.

**WE ARE THE LEADER IN THE MANUFACTURE OF GASKETS,
TECHNICAL RUBBER AND OTHER RUBBER PRODUCTS**

...Immediate sealing effect

WHY COOPERATION WITH US?

- wide range of seals available
- very short delivery time
- custom manufacturing of technical rubber
- ISO 9001: 2016 certification
- ISO 14001: 2016 certification
- timely delivery



All prices in the catalogue are stated in CZK and without VAT. Prices are valid since the latest catalogue issue until the issue of a new catalogue version. Photos are illustrative. Printing errors and all rights reserved.



GLUCE A DEŠKY PRO KONKRETNÍ STAVBY
ADITEG. GUMI A GUMA, TO JE PŘEDLÍ PRO VAŠE KONĚ...

ADITEG s.r.o.
příjemně vstříbný

- více kontrol, více bezpečnosti
- více času, protože máme v ústředí
- více lidí, kteří vám pomohou, než jen
- více zkušeností, než jen
- více služeb, než jen

...a to všechno na www.ADITEG.cz

tel: +420 585 30222, fax: +420 585 0224, e-mail: info@aditeg.cz

QMS
CERTIFIED SYSTEMS

ABOUT US





...Immediate sealing effect

NATURAL RUBBER (NR)

- + very good elasticity as well as mechanical properties (strength, ductility, abrasion resistance)
- + under stress - low permanent deformation, high resistance to alternating bending
- poor resistance to oil, ozone, weather conditions and heat
- flammable

STYRENE-BUTADIENE RUBBER (SBR)

- + better abrasion and age resistance than by NR
- + tolerates higher temperatures than NR in a short term
- similar like NR, but less elastic, resulting in low resilience and thus a large temperature increase
- under dynamic stress, poor notch strength, flammable

BUTYL RUBBER (IIR)

- + good resistance to ozone and weather conditions, very low gas and air permeability
- + good electrical insulation properties
- + good low temperature behavior, highly damping material for aperiodic vibrations
- + good resistance to hot water and chemicals
- low resilience, not resistant to oils and greases
- flammable

ETHYLENE-PROPYLENE DIENE MONOMER (EPDM)

- + excellent resistance to age, weather conditions, ozone, chemicals, hot water, steam and polar solvents such as acetone, methanol or esters
- + excellent electrical insulation properties
- + very good heat resistance and good low temperature behavior
- low resistance to aliphatic and aromatic hydrocarbons (mineral oils, petrol, fuels)
- flammable

NITRILE BUTADIENE RUBBER (NBR)

- + very good resistance to oils and petrol, good mechanical properties, low permanent deformation in compression
- + better heat resistance than SBR, low gas permeability
- poor weather resistance, flammable with toxic flue gases
- poor resistance to aromatic and polar solvents

HYDRATED NITRILE RUBBER (HNBR)

- + very good mechanical properties, very good abrasion and heat resistance
- + very good resistance to age, ozone and weather conditions
- + excellent resistance to oils, greases and fuels, very good resistance to hot water and steam
- poor resistance to aromatic and polar solvents
- poor electrical insulation, flammable with toxic flue gases

CHLOROPRENE RUBBER (CR)

- + good resistance to heat, age, ozone and weather conditions
- + average oil resistance, good mechanical properties and elasticity, high resistance to alternating bending
- + does not burn in its own flame
- Individual CR types undergo less or more self-reinforcement and eventually at lower temperature crystallization occurs
- poor fuel resistance

CHLOROSULPHONE POLYETHYLENE (CSM)

- + good resistance to age, ozone and weather conditions, low air permeability
- + good resistance to chemicals (especially strongly oxidized)
- poor resistance to low temperatures
- poor fuel resistance

ACRYLIC RUBBER (ACM)

- + good resistance to age, ozone and weather conditions
- + very good resistance to oils, greases and fuels
- + high heat resistance
- poor resistance to chemicals, hydrolysis and low temperatures
- poor mechanical properties and low elasticity

POLYURETHANE RUBBER (PU)

- + good resistance to age, ozone and weather conditions
- + very good abrasion resistance, very good notch and tensile strength
- + low gas permeability
- very sensitive to water, particularly above 50 ° C
- at higher temperatures permanent deformation occurs, flammable

...Immediate sealing effect

SILICONE RUBBER (Q)

- + very good resistance to high and low temperatures
- + excellent resistance to aging, ozone and weather conditions
- + good electrical insulation properties, mechanical values remain constant over a wide temperature range
- + physiologically perfect
- average mechanical properties
- average oil resistance
- sensitive to hot water and steam
- poor fuel resistance

FLUORSILICONE RUBBER (MFQ)

- + very good resistance to high and low temperatures
- + excellent resistance to aging, ozone and weather conditions
- + good electrical insulation properties, mechanical values remain constant over a wide temperature range
- + good resistance to oils and fuels
- average mechanical propertie
- very high price

FLUORO RUBBER (FPM)

- + very high resistance to heat, excellent resistance to age, ozone and weather conditions
- + very good resistance to chemicals, low gas permeability
- + does not burn in its own flame
- sensitive to hot water, steam, acids, amines and polar solvents
- poor resistance at low temperatures

POLYTETRAFRUORETHYLENE - TEFLON (PTFE)

- + chemical resistance
- + Resistance to aging and high temperatures
- + low water absorption and solvent resistance
- degrades with a higher dose of radioactive radiation
- good sliding properties

SHEETS

Rubber sheets find their application in many industries where insulation, protective and damping properties can be used. The sheets are divided into: **RUBBER, FOAM and FLOOR** sheets according to production technology, selected material and surface structure.

Due to their properties, which include among other things high formability, flexibility, airtightness, non-absorbency and mechanical resistance, their use can vary.

They are offered in **ROLLS or SHEETS** of the required format by default. Default size in stock is 1200x10000mm and width 1400/1500/1800 / 2000mm, prices and availability on request.

They are suitable for both exterior and interior use.

If you tell us the purpose for which you want to use the sheets, we will recommend a material with such properties that meet all of your expectations.

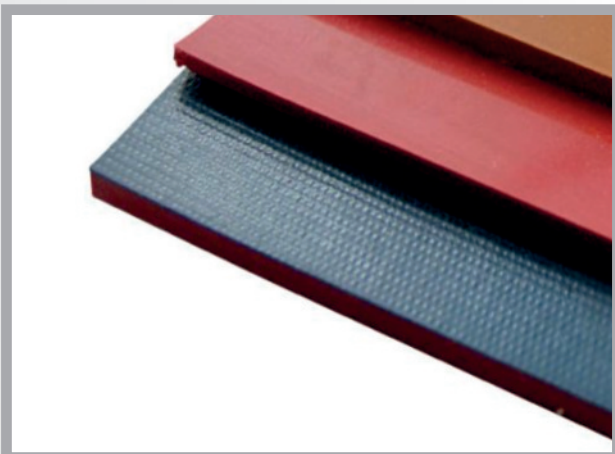

RUBBER SHEETS

SBR MATERIAL



Rubber sheets are used in many industries as sealing and impact elements or serve as a semi-finished material for manufacture of various sealing and damping elements, insulating layers, etc.

They are made with either a smooth or textured surface. Inside, the sheets can be reinforced with a textile insert. As per default, they are supplied in rolls or sheets in the thickness of 0.1 - 50mm.

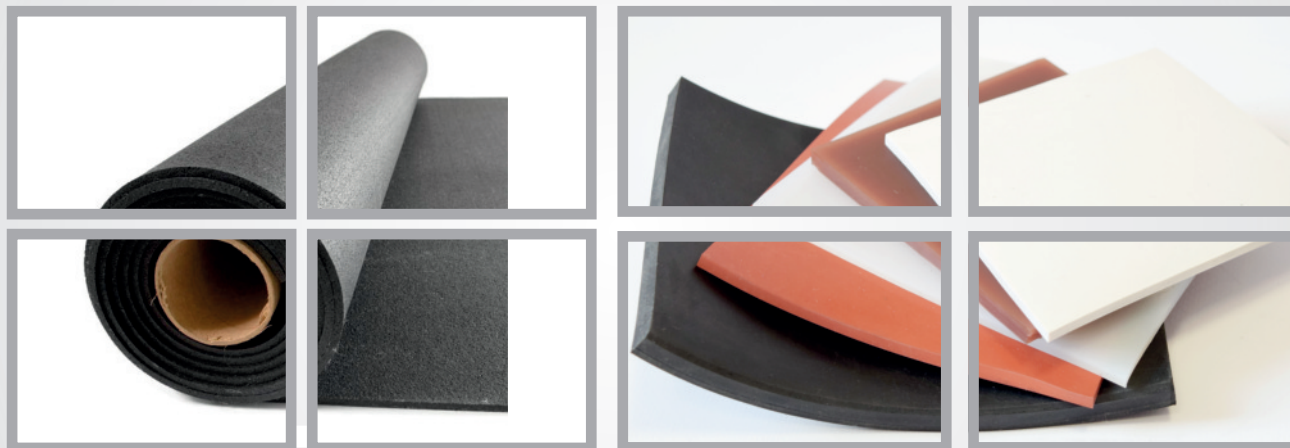

Not specified thickness will be agreed according to specific customer requirements. Depending on the mixture, the rubber sheets also have different characteristics, mechanical resistance, oil resistance, acid resistance and density. They can be normally shaped by carving or cutting.

SBR 65 +/- 10 Sh., 2-3 MPa		
thickness	price	
	1 - 11,99m ²	12 - 119,99m ²
1mm	90,90	50,70
1,5mm	145,20	79,20
2mm	185,90	101,30
2,5mm	241,90	132,00
3mm	278,40	151,80
3,5mm	338,40	184,50
4mm	371,50	191,30
5mm	464,20	239,00
6mm	557,10	286,80
8mm	742,70	382,40
10mm	942,10	485,10
12mm	958,40	493,50
15mm	1.197,60	616,70
20mm	1.595,90	821,80
25mm	1.995,50	1.027,60
30mm	2.393,80	1.320,70
40mm	3.191,80	1.761,00
50mm	3.989,70	2.201,30

SBR 65 +/- 10 Sh., 5 MPa		
thickness	price	
	1 - 11,99m ²	12 - 119,99m ²
1mm	142,50	73,30
1,5mm	213,70	110,10
2mm	286,40	147,50
2,5mm	347,90	179,20
3mm	417,40	214,90
3,5mm	486,10	250,30
4mm	555,60	286,10
5mm	695,20	358,00
6mm	833,30	429,20
8mm	1.112,60	572,90
10mm	1.390,40	715,90
12mm	1.668,20	859,00
15mm	2.085,60	1.074,00
20mm	2.782,20	1.432,70
25mm	3.477,50	1.790,60
30mm	4.172,70	2.148,70
40mm	5.564,50	2.865,30
50mm	6.954,90	3.581,40

SBR 65 +/- 10 Sh., 7-8 MPa		
thickness	price	
	1 - 11,99m ²	12 - 119,99m ²
1mm	217,10	133,60
1,5mm	294,90	181,50
2mm	393,30	242,10
2,5mm	491,60	302,60
3mm	590,40	363,40
3,5mm	688,80	424,00
4mm	786,60	484,20
5mm	982,80	604,90
6mm	1.179,90	726,30
8mm	1.572,30	967,80
10mm	1.965,60	1.209,80
12mm	2.358,80	1.452,00
15mm	2.948,30	1.814,70
20mm	3.931,10	2.419,60
25mm	4.911,10	3.022,80
30mm	6.975,70	3.628,90
40mm	7.861,30	4.838,70
50mm	9.825,80	6.048,00

ADI01 SBR 50 +/- 5 Sh., 4 MPa		
thickness 	price	
	1 - 11,99m ²	12 - 119,99m ²
1mm	198,00	110,10
2mm	396,00	220,00
3mm	594,00	330,00
4mm	792,00	440,00
5mm	990,00	550,00
6mm	1.188,00	660,00
8mm	1.584,00	880,00
10mm	1.980,00	1.100,00
12mm	2.376,00	1.320,00
15mm	2.970,00	1.650,00
20mm	3.960,00	2.200,00
25mm	4.950,00	2.750,00
30mm	5.940,00	3.300,00
40mm	7.920,00	4.400,00
50mm	9.900,00	5.500,00

ADI01 SBR 60 +/- 5 Sh., FDA light, 6 MPa		
thickness 	price	
	1 - 11,99m ²	12 - 119,99m ²
1mm	684,00	380,10
2mm	1.368,00	760,00
3mm	2.052,00	1.140,00
4mm	2.736,00	1.520,00
5mm	3.420,00	1.900,00
6mm	4.104,00	2.280,00
8mm	5.472,00	3.040,00
10mm	6.840,00	3.800,00
12mm	8.208,00	4.560,00
15mm	10.260,00	5.700,00
20mm	13.680,00	7.600,00
25mm	17.100,00	9.470,80
30mm	20.520,00	11.400,00
40mm	27.360,00	15.200,00
50mm	34.200,00	19.000,00

ADI01 NR / SBR 70 +/- 5 Sh. with slide, 3-4 MPa		
thickness 	price	
	1 - 11,99m ²	12 - 119,99m ²
1mm	156,00	86,60
2mm	312,00	173,30
3mm	435,60	242,00
4mm	580,80	321,80
5mm	726,00	403,40
6mm	871,20	483,90
8mm	1.161,60	645,30
10mm	1.452,00	806,70
12mm	1.742,40	968,00
15mm	2.178,00	1.210,00
20mm	2.904,00	1.613,30
25mm	3.630,00	2.016,70
30mm	4.356,00	2.420,00
40mm	5.808,00	3.226,70
50mm	7.260,00	4.033,40

SBR 65 +/- 10 Sh., 2-3 MPa 1x textile insert		
thickness 	price	
	1 - 11,99m ²	12 - 119,99m ²
2mm	225,30	104,90
2,5mm	281,60	131,10
3mm	338,70	157,70
3,5mm	395,20	183,90
4mm	450,60	209,70
5mm	564,00	262,50
6mm	675,80	314,60
8mm	901,00	419,50
10mm	1.126,30	524,30
12mm	1.426,10	663,90
15mm	1.780,40	828,80
20mm	2.377,00	1.106,60
25mm	2.971,20	1.383,20
30mm	3.565,40	1.659,70
40mm	4.753,90	2.213,00
50mm	5.942,40	2.766,30

SBR 65 +/- 10 Sh., 5 MPa 1x textile insert		
thickness 	price	
	1 - 11,99m ²	12 - 119,99m ²
2mm	388,40	180,80
2,5mm	437,00	226,00
3mm	526,60	245,20
3,5mm	554,30	286,60
4mm	703,70	327,60
5mm	879,30	409,30
6mm	1.054,80	491,10
8mm	1.407,60	655,20
10mm	1.760,20	819,40
12mm	2.111,30	982,80
15mm	2.639,50	1.228,70
20mm	3.520,40	1.638,80
25mm	4.400,50	2.048,50
30mm	5.280,60	2.458,20
40mm	7.040,70	3.277,60
50mm	8.801,00	4.097,00

SBR 65 +/- 10 Sh., 2-3 MPa 1x nylon insert		
thickness 	price	
	1 - 11,99m ²	12 - 119,99m ²
2mm	356,50	166,00
2,5mm	413,90	192,70
3mm	461,40	214,80
3,5mm	511,70	238,20
4mm	565,20	263,10
5mm	668,70	311,40
6mm	772,50	359,60
8mm	979,90	456,20
10mm	1.187,40	552,70
12mm	1.394,70	649,30
15mm	1.706,90	794,70
20mm	2.250,00	1.047,40
25mm	2.812,50	1.309,30
30mm	3.299,80	1.536,10
40mm	4.444,00	2.068,70
50mm	5.518,40	2.568,90

**SBR 65 +/- 10 Sh., 2-3 MPa
2 textile inserts**

thickness	price	
	1 - 11,99m ²	12 - 119,99m ²
4mm	576,70	268,50
5mm	721,20	335,80
6mm	865,70	403,10
8mm	1.154,70	537,50
10mm	1.443,60	672,10
12mm	1.731,50	806,00
15mm	2.164,90	1.007,70
20mm	2.886,20	1.343,50
25mm	3.607,60	1.679,40
30mm	4.329,80	2.015,60
40mm	5.893,50	2.743,50
50mm	7.367,40	3.429,60



...Immediate sealing effect

RUBBER SHEETS

NBR MATERIAL

NBR/SBR 65 +/- 5 Sh., 2-3 MPa

thickness	price	
	1 - 11,99m ²	12 - 119,99m ²
1mm	167,20	89,20
1,5mm	241,90	124,10
2mm	310,00	165,30
2,5mm	372,50	198,70
3mm	466,20	248,70
3,5mm	522,00	278,50
4mm	621,20	331,30
5mm	776,20	414,00
6mm	931,20	496,70
8mm	1.242,40	662,40
10mm	1.552,40	828,00
12mm	1.862,40	993,30
15mm	2.327,30	1.241,20
20mm	3.103,50	1.655,20
25mm	4.078,10	2.069,10
30mm	4.655,90	2.482,90
40mm	6.206,90	3.310,50
50mm	7.759,30	4.138,10

NBR/SBR 65 +/- 5 Sh., 5 MPa

thickness	price	
	1 - 11,99m ²	12 - 119,99m ²
1mm	203,90	116,50
1,5mm	305,90	174,70
2mm	407,80	233,10
2,5mm	509,80	291,30
3mm	603,60	344,80
3,5mm	705,30	403,10
4mm	806,10	460,60
5mm	1.007,30	575,60
6mm	1.208,50	690,60
8mm	1.612,20	924,50
10mm	2.015,90	1.151,90
12mm	2.418,30	1.381,90
15mm	3.023,20	1.727,60
20mm	4.031,90	2.304,00
25mm	5.039,90	2.879,90
30mm	6.047,90	3.455,90
40mm	8.063,80	4.607,90
50mm	10.078,50	5.759,10

NBR/SBR 65 +/- 5 Sh., 7-8 MPa

thickness	price	
	1 - 11,99m ²	12 - 119,99m ²
1mm	282,40	161,40
1,5mm	390,00	222,80
2mm	519,90	297,10
2,5mm	649,90	371,40
3mm	780,00	445,70
3,5mm	909,90	519,90
4mm	1.039,90	594,20
5mm	1.298,90	742,20
6mm	1.559,80	891,30
8mm	2.078,90	1.187,90
10mm	2.598,80	1.485,00
12mm	3.118,70	1.782,10
15mm	3.897,70	2.227,30
20mm	5.197,60	2.970,00
25mm	6.497,00	3.712,50
30mm	7.796,30	4.455,10
40mm	10.478,70	5.987,80
50mm	13.096,90	7.484,00

ADI01 NBR 65 +/- 5 Sh. with slide 5 MPa		
 thickness	price	
	1 - 11,99m ²	12 - 119,99m ²
1mm	240,00	133,40
2mm	480,00	266,70
3mm	720,00	400,00
4mm	960,00	533,30
5mm	1.200,00	666,70
6mm	1.440,00	800,00
8mm	1.920,00	1.066,70
10mm	2.400,00	1.333,40
12mm	2.880,00	1.600,00
15mm	3.600,00	2.000,10
20mm	4.800,00	2.666,60
25mm	6.000,00	3.333,30
30mm	7.200,00	4.000,00
40mm	9.600,00	5.333,40
50mm	12.000,00	6.666,60

ADI01 NBR 60 +/- 5 Sh., FDA light, 5 MPa		
 thickness	price	
	1 - 11,99m ²	12 - 119,99m ²
1mm	702,00	390,00
2mm	1.404,00	780,00
3mm	2.106,00	1.170,00
4mm	2.808,00	1.560,00
5mm	3.510,00	1.950,00
6mm	4.212,00	2.340,00
8mm	5.616,00	3.120,00
10mm	7.020,00	3.900,00
12mm	8.424,00	4.680,00
15mm	10.530,00	5.850,00
20mm	14.040,00	7.800,00
25mm	17.550,00	9.750,00
30mm	21.060,00	11.700,00
40mm	28.080,00	15.600,00
50mm	35.100,00	19.500,00

NBR/SBR 65 +/- 5 Sh., 2-3 MPa 1x textile insert		
 thickness	price	
	1 - 11,99m ²	12 - 119,99m ²
2mm	323,60	184,90
2,5mm	405,50	231,80
3mm	486,60	278,10
3,5mm	566,10	323,60
4mm	647,00	369,80
5mm	810,20	463,00
6mm	977,40	558,50
8mm	1.294,20	739,50
10mm	1.614,90	922,90
12mm	1.943,90	1.110,80
15mm	2.429,20	1.388,10
20mm	3.239,40	1.851,10
25mm	4.049,20	2.313,90
30mm	4.859,80	2.777,00
40mm	6.478,80	3.702,10
50mm	8.099,10	4.628,10

NBR/SBR 65 +/- 5 Sh., 5 MPa 1x textile insert		
 thickness	price	
	1 - 11,99m ²	12 - 119,99m ²
2mm	435,00	248,60
2,5mm	543,80	310,70
3mm	645,70	368,90
3,5mm	755,40	431,60
4mm	860,40	491,70
5mm	1.075,20	614,40
6mm	1.291,40	738,00
8mm	1.721,10	983,40
10mm	2.151,90	1.229,70
12mm	2.582,80	1.475,90
15mm	3.227,10	1.844,10
20mm	4.303,80	2.459,30
25mm	5.379,70	3.074,10
30mm	6.455,70	3.689,00
40mm	8.607,60	4.918,60
50mm	10.759,50	6.148,20

NBR/SBR 65 +/- 5 Sh., 2-3 MPa 1x nylon insert		
 thickness	price	
	1 - 11,99m ²	12 - 119,99m ²
2mm	424,10	242,40
2,5mm	475,70	271,80
3mm	571,00	326,30
3,5mm	666,10	380,60
4mm	717,80	410,20
5mm	864,60	494,10
6mm	1.011,40	577,90
8mm	1.305,10	745,70
10mm	1.598,60	913,60
12mm	1.863,10	1.081,30
15mm	2.332,70	1.332,90
20mm	3.115,70	1.780,40
25mm	3.894,60	2.225,40
30mm	4.608,40	2.633,40
40mm	6.198,80	3.542,20
50mm	7.715,80	4.409,10

NBR/SBR 65 +/- 5 Sh., 2-3 MPa 2x textile inserts		
 thickness	price	
	1 - 11,99m ²	12 - 119,99m ²
4mm	790,00	420,10
5mm	986,90	524,90
6mm	1.183,80	629,50
8mm	1.578,90	839,60
10mm	1.973,80	1.111,40
12mm	2.367,70	1.333,30
15mm	2.959,50	1.666,50
20mm	3.946,40	2.222,20
25mm	4.933,30	2.778,00
30mm	5.920,20	3.333,60
40mm	8.117,80	4.571,10
50mm	10.148,70	5.714,70

RUBBER SHEETS

EPDM MATERIAL



RUBBER SHEETS

EPDM/SBR 65 +/- 5 SH., 2-3 MPa		
thickness	price	
	1 - 11,99m ²	12 - 119,99m ²
1mm	133,80	95,60
1,5mm	203,40	145,30
2mm	248,00	177,10
2,5mm	313,20	223,70
3mm	373,00	266,40
3,5mm	438,30	313,10
4mm	486,20	355,00
5mm	621,00	443,60
6mm	745,00	532,10
8mm	993,90	710,00
10mm	1.241,90	887,10
12mm	1.489,90	1.064,20
15mm	1.861,80	1.330,10
20mm	2.482,80	1.773,40
25mm	3.103,70	2.216,90
30mm	3.724,70	2.660,50
40mm	4.965,50	3.546,80
50mm	6.207,40	4.433,90

EPDM/SBR 65 +/- 5 Sh., 5 MPa		
thickness	price	
	1 - 11,99m ²	12 - 119,99m ²
1mm	157,70	112,60
1,5mm	237,10	169,30
2mm	298,00	212,90
2,5mm	372,50	266,00
3mm	447,00	319,20
3,5mm	521,40	372,50
4mm	595,90	425,60
5mm	745,00	532,10
6mm	893,90	638,50
8mm	1.190,80	850,60
10mm	1.489,90	1.064,20
12mm	1.786,80	1.276,20
15mm	2.233,80	1.595,50
20mm	2.978,60	2.127,60
25mm	3.723,60	2.659,70
30mm	4.468,50	3.180,10
40mm	5.957,30	4.255,20
50mm	7.447,20	5.319,40

EPDM/SBR 65 +/- 5 Sh., 7-8 MPa		
thickness	price	
	1 - 11,99m ²	12 - 119,99m ²
1mm	251,00	151,80
1,5mm	376,60	227,90
2mm	462,20	279,60
2,5mm	577,30	349,30
3mm	693,30	419,50
3,5mm	808,80	489,30
4mm	924,40	559,30
5mm	1.154,50	698,50
6mm	1.386,60	838,90
8mm	1.847,90	1.118,00
10mm	2.310,00	1.397,60
12mm	2.772,30	1.677,30
15mm	3.464,60	2.096,20
20mm	4.620,00	2.795,40
25mm	5.775,10	3.494,10
30mm	6.930,10	4.193,00
40mm	9.314,50	5.635,70
50mm	11.641,60	7.043,80

EPDM/SBR 65 +/- 5 SH., 2-3 MPa 1x textile insert		
thickness	price	
	1 - 11,99m ²	12 - 119,99m ²
2mm	371,30	185,70
2,5mm	463,50	231,80
3mm	556,20	278,10
3,5mm	649,80	325,00
4mm	742,60	371,30
5mm	927,50	463,80
6mm	1.112,40	556,20
8mm	1.483,70	741,90
10mm	1.851,90	925,90
12mm	2.221,60	1.110,80
15mm	2.776,20	1.388,10
20mm	3.702,10	1.851,10
25mm	4.627,80	2.313,90
30mm	5.554,00	2.777,00
40mm	7.404,40	3.702,10
50mm	9.256,10	4.628,10

EPDM/SBR 65 +/- 5 Sh., 5 MPa 1x textile insert		
thickness	price	
	1 - 11,99m ²	12 - 119,99m ²
2mm	402,70	253,60
2,5mm	498,20	313,60
3mm	597,80	376,40
3,5mm	697,00	438,90
4mm	796,60	501,60
5mm	995,40	626,70
6mm	1.195,50	752,70
8mm	1.593,10	1.003,10
10mm	1.992,10	1.254,20
12mm	2.390,90	1.505,40
15mm	2.987,40	1.880,90
20mm	3.984,10	2.508,50
25mm	4.980,10	3.135,60
30mm	5.976,10	3.762,70
40mm	7.968,10	5.017,00
50mm	9.960,20	6.271,20

EPDM/SBR 65 +/- 5 Sh., 2-3 MPa 1x nylon insert		
thickness	price	
	1 - 11,99m ²	12 - 119,99m ²
2mm	433,90	248,00
2,5mm	488,60	279,20
3mm	586,20	335,00
3,5mm	645,80	369,00
4mm	738,20	421,80
5mm	889,10	508,00
6mm	1.040,90	594,90
8mm	1.344,70	768,40
10mm	1.647,50	941,40
12mm	1.951,30	1.115,10
15mm	2.442,70	1.395,90
20mm	3.213,50	1.836,30
25mm	4.017,00	2.295,40
30mm	4.828,50	2.759,20
40mm	6.394,50	3.654,00
50mm	7.960,50	4.548,90

ADI01 EPDM 65 +/- 5 Sh.		
thickness	price	
	1 - 11,99m ²	12 - 119,99m ²
1mm	270,00	150,00
2mm	540,00	300,00
3mm	810,00	450,00
4mm	1.080,00	600,00
5mm	1.350,00	750,00
6mm	1.620,00	900,00
8mm	2.160,00	1.200,00
10mm	2.700,00	1.500,00
12mm	3.240,00	1.800,00
15mm	4.050,00	2.250,00
20mm	5.400,00	3.000,00
25mm	6.750,00	3.750,00
30mm	8.100,00	4.500,00
40mm	10.800,00	6.000,00
50mm	13.500,00	7.500,00

ADI01 EPDM 60 +/- 5 Sh., FDA		
thickness	price	
	1 - 11,99m ²	12 - 119,99m ²
1mm	894,00	496,70
2mm	1.788,00	993,40
3mm	2.682,00	1.490,00
4mm	3.576,00	1.986,70
5mm	4.470,00	2.483,40
6mm	5.364,00	2.980,00
8mm	7.152,00	3.973,30
10mm	8.940,00	4.966,70
12mm	10.728,00	5.960,00
15mm	13.410,00	7.449,90
20mm	17.800,00	9.933,30
25mm	22.350,00	12.416,70
30mm	26.820,00	14.900,00
40mm	35.760,00	19.866,70
50mm	44.700,00	24.833,30

EPDM/SBR 65 +/- 5 Sh., 2-3 MPa, 2x textile inserts		
thickness	price	
	1 - 11,99m ²	12 - 119,99m ²
4mm	823,80	438,00
5mm	1.028,80	547,10
6mm	1.235,10	656,90
8mm	1.646,40	875,60
10mm	2.057,70	1.158,70
12mm	2.469,00	1.390,30
15mm	3.086,50	1.738,00
20mm	4.115,40	2.317,40
25mm	5.144,30	2.896,70
30mm	6.173,10	3.476,10
40mm	8.345,10	4.699,10
50mm	10.430,60	5.873,50

RUBBER SHEETS

MATERIAL CR

RUBBER SHEETS

CR/SBR 65 +/- 5 Sh., 2-3 MPa		
thickness	price	
	1 - 11,99m ²	12 - 119,99m ²
1mm	167,30	95,60
1,5mm	255,50	146,00
2mm	310,00	177,10
2,5mm	286,70	225,60
3mm	466,30	266,40
3,5mm	552,40	315,70
4mm	621,30	355,00
5mm	776,30	443,60
6mm	931,20	532,10
8mm	1.242,40	710,00
10mm	1.396,10	797,80
12mm	1.552,40	887,10
15mm	1.862,40	1.064,20
20mm	2.483,20	1.419,00
25mm	2.909,10	1.662,30
30mm	3.103,50	1.773,50
40mm	4.137,90	2.364,60
50mm	5.173,20	2.956,20

CR/SBR 65 +/- 5 Sh., 5 MPa		
thickness	price	
	1 - 11,99m ²	12 - 119,99m ²
1mm	197,10	112,60
1,5mm	232,40	132,80
2mm	372,50	212,90
2,5mm	465,60	266,00
3mm	558,70	319,20
3,5mm	651,80	372,50
4mm	745,00	425,60
5mm	931,20	532,10
6mm	1.117,40	638,50
8mm	1.488,60	850,60
10mm	1.862,40	1.064,20
12mm	2.233,40	1.276,20
15mm	2.791,80	1.595,30
20mm	3.723,30	2.127,60
25mm	4.654,30	2.659,60
30mm	5.585,00	3.191,40
40mm	7.446,70	4.255,20
50mm	9.308,30	5.319,00

CR/SBR 65 +/- 5 Sh., 7-8 MPa		
thickness	price	
	1 - 11,99m ²	12 - 119,99m ²
1mm	282,40	161,40
1,5mm	390,00	222,80
2mm	519,90	297,10
2,5mm	649,90	371,40
3mm	780,00	445,70
3,5mm	909,90	519,90
4mm	1.039,90	594,20
5mm	1.298,90	742,20
6mm	1.559,80	891,30
8mm	2.078,80	1.187,90
10mm	2.598,80	1.485,00
12mm	3.118,70	1.782,10
15mm	3.897,70	2.227,30
20mm	5.197,60	2.970,00
25mm	6.497,00	3.712,50
30mm	7.796,30	4.455,10
40mm	10.478,70	5.987,80
50mm	13.096,90	7.484,00

CR/SBR 65 +/- 5 Sh., 2-3 MPa 1x textile insert		
thickness	price	
	1 - 11,99m ²	12 - 119,99m ²
2mm	369,80	246,50
2,5mm	463,40	309,00
3mm	556,20	370,80
3,5mm	647,00	431,40
4mm	739,50	493,00
5mm	925,90	617,30
6mm	1.117,00	744,70
8mm	1.479,00	986,00
9mm	1.660,70	1.107,20
10mm	1.845,60	1.230,40
12mm	2.221,60	1.481,10
15mm	2.776,20	1.850,80
20mm	3.702,10	2.468,10
25mm	4.627,70	3.085,10
30mm	5.554,00	3.702,70
40mm	7.404,40	4.936,20
50mm	9.256,10	6.170,80

CR/SBR 65 +/- 5 Sh., 5 MPa 1x c		
thickness	price	
	1 - 11,99m ²	12 - 119,99m ²
2mm	460,60	263,20
2,5mm	575,70	329,00
3mm	683,60	390,60
3,5mm	799,70	456,90
4mm	911,10	520,70
5mm	1.138,50	650,60
6mm	1.367,40	781,40
8mm	1.822,20	1.041,20
10mm	2.278,50	1.301,90
12mm	2.734,80	1.562,80
15mm	3.417,00	1.952,50
20mm	4.557,00	2.604,00
25mm	5.696,10	3.255,00
30mm	6.835,40	3.905,90
40mm	9.113,90	5.208,00
50mm	11.392,40	6.509,90

CR/SBR 65 +/- 5 Sh., 2-3MPa 1x nylon insert		
thickness	price	
	1 - 11,99m ²	12 - 119,99m ²
2mm	551,00	257,10
2,5mm	620,40	289,50
3mm	744,40	347,40
3,5mm	820,20	382,80
4mm	937,30	437,40
5mm	1.128,90	526,80
6mm	1.321,80	616,90
8mm	1.707,60	796,90
10mm	2.092,20	976,30
12mm	2.478,00	1.156,40
15mm	3.102,00	1.447,60
20mm	4.080,70	1.904,40
25mm	5.100,80	2.380,40
30mm	6.131,40	2.861,40
40mm	8.120,00	3.789,30
50mm	10.108,60	4.717,30

CR/SBR 65 +/- 5 Sh., 2-3 MPa 2x textile inserts		
thickness	price	
	1 - 11,99m ²	12 - 119,99m ²
4mm	790,00	378,10
5mm	986,90	472,40
6mm	1.183,80	566,60
8mm	1.578,90	755,70
10mm	1.973,80	944,80
12mm	2.367,70	1.133,20
15mm	2.959,50	1.416,50
20mm	3.946,40	1.888,90
25mm	4.933,10	2.361,20
30mm	5.920,20	2.833,60
40mm	8.117,80	3.885,40
50mm	10.148,70	4.857,50

RUBBER SHEETS

MATERIAL FPM / SILICONE / NR / P

FPM 70 +/- 5 Sh.		
thickness 	price	
	1 - 11,99m ²	12 - 119,99m ²
1mm	4.000,30	2.165,60
1,5mm	5.789,30	3.134,10
2mm	7.719,10	4.178,70
2,5mm	9.648,90	5.223,40
3mm	11.578,70	6.268,10
3,5mm	13.508,40	7.312,00
4mm	15.438,30	8.357,60
5mm	19.295,70	10.445,80
6mm	23.126,50	12.519,60
8mm	30.844,50	16.697,80
10mm	38.595,60	20.893,90
12mm	46.314,70	25.072,60
15mm	57.893,40	31.340,70
20mm	77.191,20	41.787,70

Silicone 60 +/- 5 Sh., white, red, transparent, green		
thickness 	price	
	1 - 11,99m ²	12 - 119,99m ²
1mm	834,20	476,70
1,5mm	1.217,10	695,50
2mm	1.622,70	927,30
2,5mm	2.028,60	1.159,20
3mm	2.434,10	1.390,90
3,5mm	2.840,20	1.622,90
4mm	3.245,90	1.854,80
5mm	4.056,80	2.318,10
6mm	4.868,10	2.781,80
8mm	5.980,00	3.417,10
10mm	8.113,40	4.636,20
12mm	9.736,10	5.563,50
15mm	12.170,20	6.954,30
20mm	16.226,80	9.272,40

NR / SBR 50 +/- 5 Sh. gray / white		
thickness 	price	
	1 - 11,99m ²	12 - 119,99m ²
1mm	315,10	225,10
1,5mm	472,70	337,60
2mm	630,30	450,10
2,5mm	787,90	562,80
3mm	946,40	676,00
3,5mm	1.103,90	788,50
4mm	1.261,50	901,00
5mm	1.576,60	1.126,10
6mm	1.891,70	1.351,30
8mm	2.837,20	2.026,50
10mm	3.152,30	2.251,70
12mm	3.782,60	2.701,80
15mm	4.728,90	3.377,80
20mm	6.304,60	4.503,30
25mm	7.880,80	5.629,10
30mm	9.456,90	6.755,00
40mm	12.609,20	9.006,60
50mm	15.761,50	11.258,20

ADI01 NR 40 +/- 5 Sh. gray / beige		
thickness 	price	
	1 - 11,99m ²	12 - 119,99m ²
1mm	823,20	457,40
1,5mm	1.234,80	686,00
2mm	1.646,40	914,70
2,5mm	2.058,00	1.143,30
3mm	2.469,60	1.372,00
3,5mm	3.292,80	1.829,30
4mm	4.116,00	2.286,70
5mm	4.939,20	2.744,00
6mm	6.585,60	3.658,70
8mm	8.232,00	4.573,40
10mm	12.348,00	6.860,10
12mm	16.464,00	9.146,60
15mm	20.580,00	11.433,30
20mm	24.696,00	13.720,00
25mm	20.580,00	11.433,30
30mm	24.696,00	13.720,00
40mm	32.928,00	18.293,40
50mm	41.160,00	22.866,60

PU 70 70 +/- 5 Sh. Brown		
thickness 	price	
	1 - 11,99m ²	12 - 119,99m ²
1mm	599,80	556,90
1,5mm	839,10	779,20
2mm	1.108,90	1.029,80
2,5mm	1.377,50	1.279,20
3mm	1.619,30	1.503,60
4mm	2.158,20	2.004,00
5mm	2.668,40	2.477,80
6mm	3.175,80	2.948,90
8mm	4.209,10	3.908,50
10mm	4.973,50	4.618,30
12mm	6.217,50	5.773,40
15mm	7.461,40	6.928,50
20mm	9.948,90	9.238,30

RUBBER SHEETS

FOAM



The porous rubber compound sheets are characterized by low thermal conductivity, low hardness, high flexibility, airtightness or non-absorbency. Thanks to these characteristics, it offers a wide range of applications mainly in engineering and air-conditioning as a thermal insulator, sealing element or vibration and noise damper.

They are processed in many ways, such as cutting, carving, gluing, etc. They may come into a contact with non-aggressive substances such as wood, rubber, glass, water, textiles, etc.

Some sheets may be provided with a self-adhesive layer for easier attachment to the substrate. The surface of the substrate must be dry, degreased and smooth.

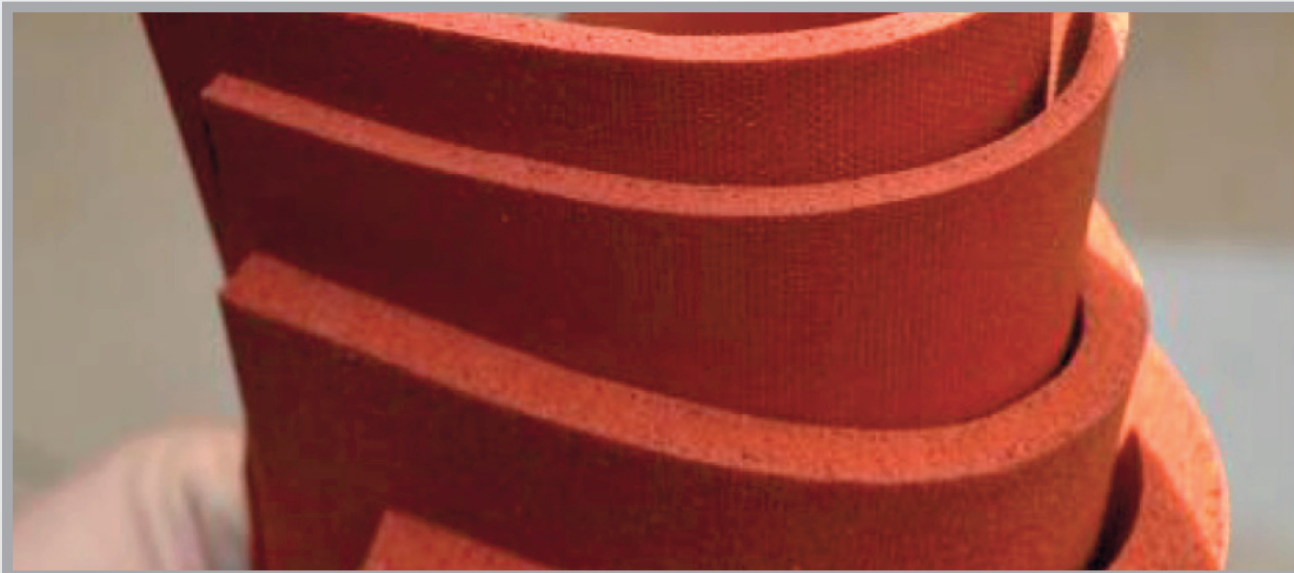

RUBBER SHEETS

FOAM

Foam CR - black 2000x1000mm - 140 +/- 25kg / m ³		
thickness	Price	
	1 - 9,99m ²	od 10m ²
1mm	100,70	80,60
2mm	172,10	137,70
3mm	243,60	194,90
4mm	315,00	252,00
5mm	386,50	309,20
6mm	457,90	366,30
7mm	529,30	423,50
8mm	600,80	480,60
9mm	672,20	537,80
10mm	751,90	601,50
11mm	823,40	658,70
12mm	894,80	715,80
13mm	966,20	773,00
14mm	1.037,70	830,20
15mm	1.109,10	887,30
16mm	1.180,60	944,50
18mm	1.323,50	1.058,80
20mm	1.503,80	1.203,10
25mm	1.861,10	1.488,80
30mm	2.218,30	1.774,60
40mm	2.932,70	2.346,10
50mm	3.647,10	2.917,70

Foam CR - black 2000x1000mm - 175 +/- 25kg / m ³		
thickness	Price	
	1 - 9,99m ²	od 10m ²
1mm	126,70	101,40
2mm	224,20	179,40
3mm	321,70	257,40
4mm	419,20	335,40
5mm	516,70	413,40
6mm	614,20	491,30
7mm	711,70	569,30
8mm	809,20	647,30
9mm	906,60	725,30
10mm	1.012,40	809,90
11mm	1.109,90	887,90
12mm	1.207,40	965,90
13mm	1.304,90	1.043,90
14mm	1.402,30	1.121,90
15mm	1.499,80	1.199,90
16mm	1.597,30	1.277,90
18mm	1.792,30	1.433,80
20mm	2.024,80	1.619,80
25mm	2.512,20	2.009,80
30mm	2.999,70	2.399,70
40mm	3.974,50	3.179,60
50mm	4.949,40	3.959,50

Foam CR - gray 1900x1000mm - 195 +/- 25kg / m ³		
thickness	Price	
	1 - 9,99m ²	od 10m ²
1mm	231,40	185,10
2mm	433,60	346,80
3mm	635,70	508,60
4mm	837,90	670,30
5mm	1.040,00	832,00
6mm	1.242,20	993,70
7mm	1.444,30	1.155,50
8mm	1.646,50	1.317,20
9mm	1.848,60	1.478,90
10mm	2.059,00	1.647,20
11mm	2.261,20	1.809,00
12mm	2.463,40	1.970,70
13mm	2.666,50	2.132,40
14mm	2.867,70	2.294,10
15mm	3.069,80	2.455,90
16mm	3.272,00	2.617,60
18mm	3.676,30	2.941,00
20mm	4.118,10	3.294,50
25mm	5.128,90	4.103,10
30mm	6.139,60	4.911,70

Foam silicone 430kg / m ³ 1000x2000mm				
thickness	Price			
	0,9 - 9,99m ²	10 - 24,99m ²	25 - 99,99m ²	od 100m ²
1,5mm	583,64	535,00	493,85	458,57
2mm	627,27	575,00	530,77	492,86
3mm	763,64	700,00	646,15	600,00
4mm	861,82	790,00	729,23	677,14
5mm	1.074,55	985,00	909,23	844,29
6mm	1.298,18	1.190,00	1.098,46	1.020,00
8mm	1.600,00	1.476,92	1.371,43	1.280,00
9mm	1.755,00	1.638,46	1.521,43	1.420,00
10mm	1.970,00	1.818,46	1.688,57	1.576,00
12mm	2.380,00	2.196,92	2.040,00	1.904,00
15mm	2.955,00	2.727,69	2.532,86	2.364,00
16mm	3.155,00	2.912,31	2.704,29	2.524,00
18mm	3.550,00	3.276,92	3.042,86	2.840,00
20mm	3.940,00	3.636,92	3.377,14	3.152,00
25mm	4.925,00	4.546,15	4.221,43	3.940,00

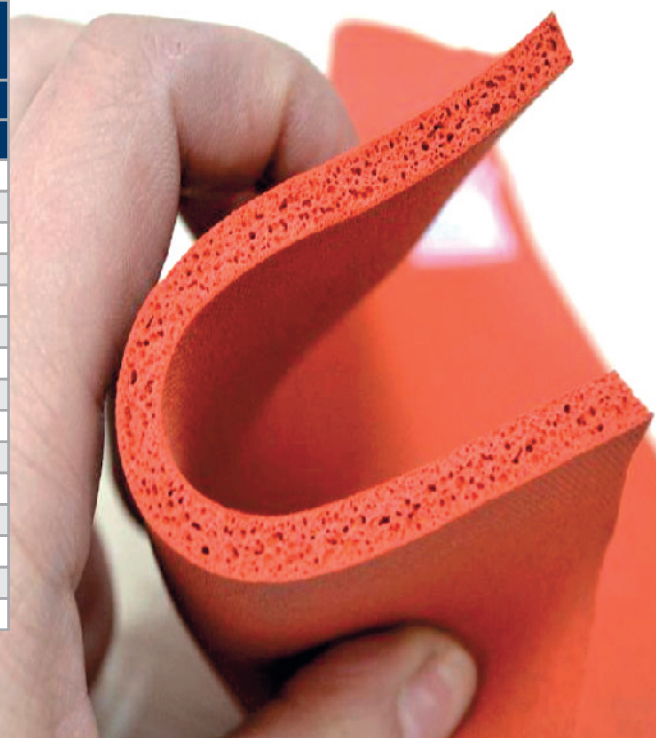

RUBBER SHEETS

Foam NBR 2000x1000mm - 130 +/- 25kg/m ³		
thickness	Price	
	1 - 9,99m ²	od 10m ²
1mm	141,90	113,50
2mm	254,60	203,70
3mm	367,30	293,80
4mm	480,00	384,00
5mm	592,70	474,10
6mm	705,30	564,30
7mm	818,00	654,40
8mm	930,70	744,60
9mm	1.043,40	834,70
10mm	1.164,30	931,50
11mm	1.277,00	1.021,60
12mm	1.389,70	1.111,70
13mm	1.502,40	1.201,90
14mm	1.615,00	1.292,00
15mm	1.727,70	1.382,20
16mm	1.840,40	1.472,30
18mm	2.065,80	1.652,60
20mm	2.328,60	1.862,90
25mm	2.892,00	2.313,60
30mm	3.455,40	2.764,40
40mm	4.582,30	3.665,80
50mm	5.709,10	4.567,30

Foam NBR 2000x1000mm - 165 +/- 25kg/m ³		
thickness	Price	
	1 - 9,99m ²	od 10m ²
1mm	162,40	129,90
2mm	295,50	236,40
3mm	428,60	342,90
4mm	561,80	449,40
5mm	694,90	555,90
6mm	828,00	662,40
7mm	961,20	768,90
8mm	1.094,30	875,40
9mm	1.227,40	981,90
10mm	1.368,80	1.095,00
11mm	1.501,90	1.201,50
12mm	1.635,10	1.308,10
13mm	1.768,20	1.414,60
14mm	1.901,30	1.521,10
15mm	2.034,50	1.627,60
16mm	2.167,60	1.734,10
18mm	2.433,80	1.947,10
20mm	2.737,60	2.190,10
25mm	3.403,30	2.722,60
30mm	4.068,90	3.255,10
40mm	5.400,20	4.320,20
50mm	6.731,50	5.385,20

Foam NBR 1550x970mm - 180 +/- 25kg/m ³		
thickness	Price	
	1 - 9,99m ²	od 10m ²
1mm	186,20	149,00
2mm	343,20	274,60
3mm	500,20	400,20
4mm	657,20	525,80
5mm	814,20	651,40
6mm	971,20	777,00
7mm	1.128,20	902,60
8mm	1.285,20	1.028,20
9mm	1.442,20	1.153,80
10mm	1.607,50	1.286,00
11mm	1.764,50	1.411,60
12mm	1.921,50	1.537,20
13mm	2.078,50	1.662,80
14mm	2.235,50	1.788,40
15mm	2.392,50	1.914,00
16mm	2.549,50	2.039,60
18mm	2.863,50	2.290,80
20mm	3.215,00	2.572,00
25mm	3.999,90	3.200,00
30mm	4.784,90	3.827,90
40mm	6.354,90	5.083,90
50mm	7.924,90	6.339,90

Foam NBR 1400x850mm - 295 +/- 25kg/m ³		
thickness	Price	
	1 - 9,99m ²	od 10m ²
1mm	268,20	214,60
2mm	507,10	405,70
3mm	746,10	596,90
4mm	985,00	788,00
5mm	1.224,00	979,20
6mm	1.462,90	1.170,40
7mm	1.701,90	1.361,50
8mm	1.940,80	1.552,70
9mm	2.179,80	1.743,80
10mm	2.427,00	1.941,06
11mm	2.665,90	2.132,80
12mm	2.904,90	2.323,90
13mm	3.143,80	2.515,10
14mm	3.382,80	2.706,20
15mm	3.621,70	2.897,40
16mm	3.860,70	3.088,60
18mm	4.338,60	3.470,90
20mm	4.854,00	3.883,20
25mm	6.048,70	4.839,00
30mm	7.243,50	5.794,80
40mm	9.633,00	7.706,40
50mm	12.022,50	9.618,00



Foam EPDM 2000x1000mm - 75 +/- 15kg/m ³		
thickness	Price	
	1 - 9,99m ²	od 10m ²
1mm	70,00	57,30
2mm	114,00	93,30
3mm	158,00	129,30
4mm	202,00	165,30
5mm	246,00	201,30
6mm	290,00	237,30
7mm	334,00	273,30
8mm	378,00	309,30
9mm	422,00	345,30
10mm	473,30	387,30
11mm	517,30	423,30
12mm	561,30	459,30
13mm	605,30	495,30
14mm	649,30	531,30
15mm	693,30	567,30
16mm	737,30	603,30
18mm	825,30	675,30
20mm	946,70	774,50
25mm	1.166,70	954,50
30mm	1.386,70	1.134,50
40mm	1.826,70	1.494,50
50mm	2.266,70	1.854,50

Foam EPDM 2000x1000mm - 90 +/- 20kg/m ³		
thickness	Price	
	1 - 9,99m ²	od 10m ²
1mm	72,20	59,10
2mm	118,30	96,80
3mm	164,50	134,60
4mm	210,70	172,40
5mm	256,90	210,20
6mm	303,00	247,90
7mm	349,20	285,70
8mm	395,40	323,50
9mm	441,60	361,30
10mm	495,10	405,00
11mm	541,20	442,80
12mm	587,40	480,60
13mm	633,60	518,40
14mm	679,70	556,20
15mm	725,90	593,90
16mm	772,10	631,70
18mm	864,40	707,30
20mm	990,10	810,10
25mm	1.221,00	999,00
30mm	1.451,80	1.187,90
40mm	1.913,60	1.565,60
50mm	2.375,30	1.943,40

Foam EPDM 2000x1000mm - 115 +/- 25kg/m ³		
thickness	Price	
	1 - 9,99m ²	od 10m ²
1mm	64,90	53,10
2mm	103,80	84,90
3mm	142,70	116,80
4mm	181,60	148,60
5mm	220,50	180,40
6mm	259,40	212,20
7mm	298,30	244,10
8mm	337,20	275,90
9mm	376,10	307,70
10mm	422,30	345,50
11mm	461,20	377,40
12mm	500,10	409,20
13mm	539,00	441,00
14mm	577,90	472,80
15mm	616,80	504,70
16mm	655,70	536,50
18mm	733,50	600,10
20mm	844,60	691,10
25mm	1.039,10	850,20
30mm	1.233,60	1.009,30
40mm	1.622,60	1.327,60
50mm	2.011,60	1.645,90

Foam EPDM 2000x1000mm - 130 +/- 20kg/m ³		
thickness	Price	
	1 - 9,99m ²	od 10m ²
1mm	73,10	59,80
2mm	120,20	98,40
3mm	167,40	136,90
4mm	214,50	175,50
5mm	261,60	214,00
6mm	308,70	252,60
7mm	355,80	291,10
8mm	403,00	329,70
9mm	450,10	368,30
10mm	504,50	412,80
11mm	551,70	451,40
12mm	598,80	489,90
13mm	645,90	528,50
14mm	693,00	567,00
15mm	740,20	605,60
16mm	787,30	644,10
18mm	881,50	721,20
20mm	1.009,10	825,60
25mm	1.244,70	1.018,40
30mm	1.480,30	1.211,20
40mm	1.951,50	1.596,70
50mm	2.422,70	1.982,20

Foam EPDM 1600x1000mm - 175 +/- 25kg/m ³		
thickness	Price	
	1 - 9,99m ²	od 10m ²
1mm	104,70	83,70
2mm	180,10	144,00
3mm	255,50	204,40
4mm	330,90	264,70
5mm	406,30	325,00
6mm	481,70	385,30
7mm	557,10	445,70
8mm	632,50	506,00
9mm	707,90	566,30
10mm	791,50	633,20
11mm	866,90	693,50
12mm	942,30	753,90
13mm	1.017,70	814,20
14mm	1.093,10	874,50
15mm	1.168,50	934,80
16mm	1.243,90	995,20
18mm	1.394,70	1.115,80
20mm	1.583,10	1.266,40
25mm	1.960,10	1.568,10
30mm	2.337,10	1.869,70
40mm	3.091,10	2.472,90
50mm	3.845,10	3.076,10

PE Foam sheet

Foam sheet, closed pores with an excellent flexibility. **Colors:**black, yellow, red, blue, green.

Resistance: Resistant to weather conditions and UV radiation. Oil resistant and slightly acid resistant.

Foam PE 33kg / m ³ 2000x1000mm - white + anthracite		
thickness	Price	
	1 - 9,99m ²	10 - 99,99m ²
1mm	31,30	28,90
2mm	43,20	39,90
3mm	55,00	50,80
4mm	66,90	61,70
5mm	78,70	72,70
6mm	90,50	83,60
7mm	102,40	94,50
8mm	114,20	105,40
9mm	126,10	116,40
10mm	143,40	132,40
11mm	155,30	143,30
12mm	167,10	154,20
13mm	178,90	165,20
14mm	190,80	176,10
15mm	202,60	187,00
16mm	214,50	198,00
18mm	238,10	219,80
20mm	286,80	264,80
25mm	346,00	319,40
30mm	405,20	374,10
40mm	523,70	483,40
50mm	642,10	592,70

Foam PE 33kg / m ³ 2000x1000mm - colored		
thickness	Price	
	1 - 9,99m ²	10 - 99,99m ²
1mm	32,50	30,00
2mm	45,50	42,00
3mm	58,40	54,00
4mm	71,40	65,90
5mm	84,40	77,90
6mm	97,40	89,90
7mm	110,40	101,90
8mm	123,40	113,90
9mm	136,30	125,90
10mm	154,80	142,90
11mm	167,80	154,90
12mm	180,80	166,90
13mm	193,80	178,90
14mm	206,80	190,90
15mm	219,70	202,80
16mm	232,70	214,80
18mm	258,70	238,80
20mm	309,70	285,80
25mm	374,60	345,80
30mm	439,50	405,70
40mm	569,30	525,50
50mm	699,10	645,40

Foam PE 45kg / m ³ 2000x1000mm - white + anthracit		
thickness	Price	
	1 - 9,99m ²	10 - 99,99m ²
1mm	34,70	32,00
2mm	49,90	46,10
3mm	65,10	60,10
4mm	80,30	74,10
5mm	95,50	88,10
6mm	110,70	102,20
7mm	125,90	116,20
8mm	141,10	130,20
9mm	156,30	144,30
10mm	177,00	163,40
11mm	192,20	177,40
12mm	207,40	191,40
13mm	222,60	205,50
14mm	237,80	219,50
15mm	253,00	233,50
16mm	268,20	247,50
18mm	298,60	275,60
20mm	354,00	326,70
25mm	429,90	396,90
30mm	505,90	467,00
40mm	657,90	607,30
50mm	809,90	747,60

Foam PE 45kg / m ³ 2000x1000mm - colored		
thickness	Price	
	1 - 9,99m ²	10 - 99,99m ²
1mm	36,20	33,40
2mm	52,80	48,80
3mm	69,50	64,20
4mm	86,20	79,60
5mm	102,90	95,00
6mm	119,50	110,40
7mm	136,20	125,70
8mm	152,90	141,10
9mm	169,60	156,50
10mm	191,70	177,00
11mm	208,40	192,40
12mm	225,10	207,80
13mm	241,80	223,20
14mm	258,40	238,60
15mm	275,10	254,00
16mm	291,80	269,30
18mm	325,10	300,10
20mm	383,50	354,00
25mm	466,90	431,00
30mm	550,20	507,90
40mm	717,00	661,80
50mm	883,70	815,80

Foam PE 60kg / m ³ 2000x1000mm - white + anthracit		
thickness	Price	
	1 - 9,99m ²	10 - 99,99m ²
1mm	41,40	40,20
2mm	63,30	62,40
3mm	85,20	84,60
4mm	107,10	106,80
5mm	129,10	129,00
6mm	151,00	151,20
7mm	172,90	173,50
8mm	194,80	195,70
9mm	216,70	217,90
10mm	244,10	245,20
11mm	266,00	267,40
12mm	287,90	289,60
13mm	309,80	311,80
14mm	331,80	334,00
15mm	353,70	356,20
16mm	375,60	378,40
18mm	419,40	422,80
20mm	488,20	490,30
25mm	597,80	601,40
30mm	707,30	712,40
40mm	926,40	934,50
50mm	1.145,50	1.156,60

Foam PE 60kg / m ³ 2000x1000mm - colored		
thickness	Price	
	1 - 9,99m ²	10 - 99,99m ²
1mm	43,60	34,80
2mm	67,60	54,10
3mm	91,70	73,30
4mm	115,70	92,60
5mm	139,80	111,80
6mm	163,90	131,10
7mm	187,90	150,30
8mm	212,00	169,60
9mm	236,00	188,80
10mm	265,60	212,50
11mm	289,60	231,70
12mm	313,70	251,00
13mm	337,80	270,20
14mm	361,80	289,50
15mm	385,90	308,70
16mm	409,90	328,00
18mm	458,10	366,40
20mm	531,20	424,90
25mm	651,50	521,20
30mm	771,80	617,40
40mm	1.012,40	809,90
50mm	1.252,90	1.002,40

Foam PE 100kg/m ³ 2000x1000mm - white + anthracite		
thickness	Price	
	1 - 9,99m ²	10 - 99,99m ²
1mm	56,40	52,00
2mm	93,20	86,10
3mm	130,10	120,10
4mm	167,00	154,10
5mm	203,80	188,10
6mm	240,70	222,20
7mm	277,60	256,20
8mm	314,40	290,20
9mm	351,30	324,30
10mm	393,70	363,40
11mm	430,50	397,40
12mm	467,40	431,40
13mm	504,30	465,50
14mm	541,10	499,40
15mm	578,00	533,50
16mm	614,90	567,60
18mm	688,60	635,60
20mm	787,30	726,80
25mm	971,60	896,90
30mm	1.156,00	1.067,10
40mm	1.524,60	1.407,30
50mm	1.893,30	1.747,60

Foam PE 100kg/m ³ 2000x1000mm - colored		
thickness	Price	
	1 - 9,99m ²	10 - 99,99m ²
1mm	60,00	55,40
2mm	100,50	92,70
3mm	140,90	130,10
4mm	181,40	167,50
5mm	221,90	204,80
6mm	262,40	242,20
7mm	302,90	279,60
8mm	343,30	316,90
9mm	383,80	354,30
10mm	429,80	396,70
11mm	470,30	434,10
12mm	510,80	471,50
13mm	551,20	508,80
14mm	591,70	546,20
15mm	632,20	583,60
16mm	672,70	620,90
18mm	753,60	695,70
20mm	859,60	793,50
25mm	1.062,00	980,30
30mm	1.264,40	1.167,10
40mm	1.669,20	1.540,80
50mm	2.074,00	1.914,50

Foam PE 120kg/m ³ 1890x930mm - white + anthracite		
thickness	Price	
	1 - 9,99m ²	10 - 99,99m ²
1mm	65,40	60,30
2mm	103,90	95,90
3mm	157,10	145,00
4mm	202,90	187,30
5mm	248,80	229,70
6mm	294,70	272,00
7mm	340,50	314,30
8mm	386,40	356,70
9mm	432,30	399,00
10mm	483,60	446,40
11mm	529,50	488,70
12mm	575,30	531,10
13mm	621,20	573,40
14mm	667,10	615,70
15mm	712,90	658,10
16mm	758,80	700,40
18mm	850,50	785,10
20mm	967,20	892,80
25mm	1.196,50	1.104,50
30mm	1.425,80	1.316,20
40mm	1.884,50	1.739,50
50mm	2.343,10	2.162,80

Foam PE 120kg/m ³ 1890x930mm - colored		
thickness	Price	
	1 - 9,99m ²	10 - 99,99m ²
1mm	69,90	64,50
2mm	112,20	103,60
3mm	170,60	157,50
4mm	220,90	203,90
5mm	271,30	250,40
6mm	321,60	296,90
7mm	372,00	343,40
8mm	422,40	389,90
9mm	472,70	436,40
10mm	528,60	487,90
11mm	578,90	534,40
12mm	629,30	580,90
13mm	679,70	627,40
14mm	730,00	673,90
15mm	780,40	720,30
16mm	830,70	766,80
18mm	931,40	859,80
20mm	1.057,20	975,80
25mm	1.309,00	1.208,30
30mm	1.560,70	1.440,70
40mm	2.064,30	1.905,50
50mm	2.567,90	2.370,40

Foam PE 200kg/m ³ 1650x830mm - white + anthracite		
thickness	Price	
	1 - 9,99m ²	10 - 99,99m ²
1mm	85,10	78,50
2mm	150,60	139,00
3mm	216,20	199,60
4mm	281,80	260,10
5mm	347,30	320,60
6mm	412,90	381,10
7mm	478,50	441,70
8mm	544,00	502,20
9mm	609,60	562,70
10mm	680,60	628,30
11mm	746,20	688,80
12mm	811,80	749,30
13mm	877,30	809,90
14mm	942,90	870,40
15mm	1.008,50	930,90
16mm	1.074,00	991,40
18mm	1.205,20	1.112,50
20mm	1.361,30	1.256,60
25mm	1.689,10	1.559,20
30mm	2.016,90	1.861,80
40mm	2.672,60	2.467,00
50mm	3.328,20	3.072,20

Foam PE 200kg/m ³ 1650x830mm - colored		
thickness	Price	
	1 - 9,99m ²	10 - 99,99m ²
1mm	91,50	84,50
2mm	163,50	150,90
3mm	235,50	217,40
4mm	307,50	283,80
5mm	379,50	350,30
6mm	451,50	416,70
7mm	523,50	483,20
8mm	595,50	549,70
9mm	667,50	616,10
10mm	745,00	687,70
11mm	817,00	754,10
12mm	889,00	820,60
13mm	960,90	887,00
14mm	1.032,90	953,50
15mm	1.104,90	1.019,90
16mm	1.176,90	1.086,40
18mm	1.320,90	1.219,30
20mm	1.489,90	1.375,30
25mm	1.849,90	1.707,360
30mm	2.209,90	2.039,90
40mm	2.929,80	2.704,50
50mm	3.649,80	3.369,00

Foam sheet EVA

Foam sheet, closed pores with an excellent flexibility. **Color:** black, yellow, red, blue, green, light gray

Resistance: Highly resistant to weather conditions and UV resistant.

Foam EVA 33kg/m ³ 2000x1000mm - white + anthracite		
thickness	Price	
	1 - 9,99m ²	10 - 99,99m ²
1mm	32,50	30,00
2mm	45,50	42,00
3mm	58,40	54,00
4mm	71,40	65,90
5mm	84,40	77,90
6mm	97,40	89,90
7mm	110,40	101,90
8mm	123,40	113,90
9mm	136,30	125,90
10mm	154,80	142,90
11mm	167,80	154,90
12mm	180,80	166,90
13mm	193,80	178,90
14mm	206,80	190,90
15mm	219,70	202,80
16mm	232,70	214,80
18mm	258,70	238,80
20mm	309,70	285,80
25mm	374,60	345,80
30mm	439,50	405,70
40mm	569,30	525,50
50mm	699,10	654,40

Foam EVA 33kg/m ³ 2000x1000mm - colored		
thickness	Price	
	1 - 9,99m ²	10 - 99,99m ²
1mm	33,70	31,10
2mm	48,00	44,30
3mm	62,20	57,40
4mm	76,50	70,60
5mm	90,70	83,70
6mm	104,90	96,90
7mm	119,20	110,00
8mm	133,40	123,20
9mm	147,70	136,30
10mm	167,40	154,50
11mm	181,60	167,70
12mm	195,90	180,80
13mm	210,10	193,90
14mm	224,40	207,10
15mm	238,60	220,20
16mm	252,80	233,40
18mm	281,30	259,70
20mm	334,80	309,00
25mm	406,00	374,80
30mm	477,20	440,50
40mm	619,60	570,90
50mm	762,00	703,40

Foam EVA 45kg/m ³ 2000x1000mm - white + anthracite		
thickness	Price	
	1 - 9,99m ²	10 - 99,99m ²
1mm	36,20	33,40
2mm	52,80	48,80
3mm	69,50	64,20
4mm	86,20	79,60
5mm	102,90	95,00
6mm	119,50	110,40
7mm	136,20	125,70
8mm	152,90	141,10
9mm	169,60	156,50
10mm	191,70	177,00
11mm	208,40	192,40
12mm	225,10	207,80
13mm	241,80	223,20
14mm	258,40	238,60
15mm	275,10	254,00
16mm	291,80	269,30
18mm	325,10	300,10
20mm	383,50	354,00
25mm	466,90	431,00
30mm	550,20	507,90
40mm	717,00	661,80
50mm	883,70	815,80

Foam EVA 45kg/m ³ 2000x1000mm - colored		
thickness	Price	
	1 - 9,99m ²	10 - 99,99m ²
1mm	37,80	34,90
2mm	56,10	51,80
3mm	74,40	68,70
4mm	92,70	85,60
5mm	111,00	102,50
6mm	129,30	119,30
7mm	147,60	136,20
8mm	165,90	153,10
9mm	184,20	170,00
10mm	208,00	192,00
11mm	226,30	208,90
12mm	244,60	225,80
13mm	262,90	242,70
14mm	281,20	259,60
15mm	299,50	276,50
16mm	317,80	293,30
18mm	354,40	327,10
20mm	416,00	384,00
25mm	507,50	468,40
30mm	599,00	552,90
40mm	782,00	721,80
50mm	965,00	890,70

Foam EVA 60kg/m ³ 2000x1000mm - white + anthracite		
thickness	Price	
	1 - 9,99m ²	10 - 99,99m ²
1mm	43,60	40,20
2mm	67,60	62,40
3mm	91,70	84,60
4mm	115,70	106,80
5mm	139,80	129,00
6mm	163,90	151,20
7mm	187,90	173,50
8mm	212,00	195,70
9mm	236,00	217,90
10mm	265,60	245,20
11mm	289,60	267,40
12mm	313,70	289,60
13mm	337,80	311,80
14mm	361,80	334,00
15mm	385,90	356,20
16mm	409,90	378,40
18mm	458,10	422,80
20mm	531,20	490,30
25mm	651,50	601,40
30mm	771,80	712,40
40mm	1.012,40	934,50
50mm	1.252,90	1.156,60

Foam EVA 60kg/m ³ 2000x1000mm - colored		
thickness	Price	
	1 - 9,99m ²	10 - 99,99m ²
1mm	45,90	42,40
2mm	72,30	66,80
3mm	98,80	91,20
4mm	125,20	115,60
5mm	151,60	139,90
6mm	178,00	164,30
7mm	204,50	188,70
8mm	230,90	213,10
9mm	257,30	237,50
10mm	289,20	267,00
11mm	315,60	291,40
12mm	342,10	315,70
13mm	368,50	340,10
14mm	394,90	364,50
15mm	421,30	388,90
16mm	447,70	413,30
18mm	500,60	462,10
20mm	578,40	533,90
25mm	710,50	655,90
30mm	842,70	777,80
40mm	1.106,90	1.021,70
50mm	1.371,10	1.265,60

Foam EVA 100kg/m³ 2000x1000mm - white + anthracite		
 thickness	Price	
	1 - 9,99m ²	10 - 99,99m ²
1mm	58,70	54,20
2mm	98,00	90,40
3mm	137,20	126,60
4mm	176,40	162,90
5mm	215,70	199,10
6mm	254,90	235,30
7mm	294,10	271,50
8mm	333,40	307,70
9mm	372,60	343,90
10mm	417,30	385,20
11mm	456,60	421,50
12mm	495,80	457,70
13mm	535,00	493,90
14mm	574,30	530,10
15mm	613,50	566,30
16mm	652,80	602,50
18mm	731,20	675,00
20mm	834,70	770,50
25mm	1.030,90	951,60
30mm	1.227,00	1.132,60
40mm	1.619,40	1.494,80
50mm	2.011,70	1.857,00

Foam EVA 100kg/m³ 2000x1000mm - colored		
 thickness	Price	
	1 - 9,99m ²	10 - 99,99m ²
1mm	62,60	57,80
2mm	105,70	97,50
3mm	148,80	137,30
4mm	191,90	177,10
5mm	234,90	216,90
6mm	278,00	256,60
7mm	321,10	296,40
8mm	364,20	336,20
9mm	407,30	376,00
10mm	455,90	420,80
11mm	499,00	460,60
12mm	542,10	500,40
13mm	585,10	540,10
14mm	628,20	579,90
15mm	671,30	619,70
16mm	714,40	659,90
18mm	800,60	739,00
20mm	911,80	841,60
25mm	1.127,20	1.040,50
30mm	1.342,60	1.239,40
40mm	1.773,50	1.637,10
50mm	2.204,40	2.034,80

Foam EVA 120kg/m³ 1890x930mm - white + anthracite		
 thickness	Price	
	1 - 9,99m ²	10 - 99,99m ²
1mm	67,40	62,20
2mm	115,30	106,40
3mm	163,10	150,60
4mm	211,00	194,80
5mm	258,90	239,00
6mm	306,80	283,20
7mm	354,70	327,40
8mm	402,60	371,60
9mm	450,40	415,80
10mm	503,80	465,10
11mm	551,70	509,30
12mm	599,60	553,50
13mm	647,50	597,70
14mm	696,30	641,90
15mm	743,20	686,10
16mm	791,10	730,20
18mm	886,90	818,60
20mm	1.007,60	930,10
25mm	1.247,00	1.151,10
30mm	1.486,40	1.372,10
40mm	1.965,30	1.814,10
50mm	2.444,10	2.256,10

Foam EVA 120kg/m³ 1890x930mm - colored		
 thickness	Price	
	1 - 9,99m ²	10 - 99,99m ²
1mm	72,10	66,50
2mm	124,70	115,10
3mm	177,30	163,60
4mm	229,80	212,20
5mm	282,40	260,70
6mm	335,00	309,30
7mm	387,60	357,80
8mm	440,20	406,30
9mm	492,80	454,90
10mm	550,90	508,50
11mm	603,50	557,00
12mm	656,00	605,60
13mm	708,60	654,10
14mm	761,20	702,70
15mm	813,80	751,20
16mm	866,40	799,80
18mm	971,60	896,80
20mm	1.101,70	1.017,00
25mm	1.364,70	1.259,70
30mm	1.627,60	1.502,40
40mm	2.153,50	1.987,80
50mm	2.679,40	2.473,30

Foam EVA 140kg/m³ 1800x880mm - white + anthracite		
 thickness	Price	
	1 - 9,99m ²	10 - 99,99m ²
1mm	73,80	68,10
2mm	128,20	118,30
3mm	182,50	168,40
4mm	236,80	218,60
5mm	291,10	268,70
6mm	345,50	318,90
7mm	399,80	369,00
8mm	454,10	419,20
9mm	508,40	469,30
10mm	568,30	524,50
11mm	622,60	574,70
12mm	676,90	624,80
13mm	731,20	675,00
14mm	785,60	725,10
15mm	839,90	775,30
16mm	894,20	825,40
18mm	1.002,90	925,70
20mm	1.136,50	1.049,10
25mm	1.408,10	1.299,80
30mm	1.679,80	1.550,60
40mm	2.223,00	2.052,00
50mm	2.766,30	2.553,50

Foam EVA 140kg/m³ 1800x880mm - colored		
 thickness	Price	
	1 - 9,99m ²	10 - 99,99m ²
1mm	79,20	73,10
2mm	138,80	128,10
3mm	198,50	183,20
4mm	258,10	238,30
5mm	317,80	293,30
6mm	377,40	348,40
7mm	437,10	403,50
8mm	496,80	458,50
9mm	556,40	513,60
10mm	621,60	573,80
11mm	681,20	628,80
12mm	740,90	683,90
13mm	800,50	739,00
14mm	860,20	794,00
15mm	919,80	849,10
16mm	979,50	904,20
18mm	1.098,80	1.014,30
20mm	1.243,10	1.147,50
25mm	1.541,40	1.422,80
30mm	1.839,70	1.698,20
40mm	2.436,30	2.248,80
50mm	3.032,80	2.799,50

FoamEVA 200kg/m ³ 1650x830mm - white + anthracite		
thickness 	Price	
	1 - 9,99m ²	10 - 99,99m ²
1mm	88,90	82,00
2mm	158,30	146,10
3mm	227,60	210,10
4mm	297,00	274,20
5mm	366,40	338,20
6mm	435,80	402,20
7mm	505,10	466,30
8mm	574,50	530,30
9mm	643,90	594,40
10mm	718,80	663,50
11mm	788,20	727,50
12mm	857,50	791,60
13mm	926,90	855,60
14mm	996,30	919,70
15mm	1.065,70	983,70
16mm	1.135,00	1.047,70
18mm	1.273,80	1.175,80
20mm	1.437,60	1.327,00
25mm	1.784,40	1.647,20
30mm	2.131,30	1.967,40
40mm	2.825,10	2.607,80
50mm	3.518,90	3.248,20

FoamEVA 200kg/m ³ 1650x830mm - colored		
thickness 	Price	
	1 - 9,99m ²	10 - 99,99m ²
1mm	95,70	88,30
2mm	171,90	158,70
3mm	248,10	229,00
4mm	324,30	299,30
5mm	400,50	369,70
6mm	476,70	440,00
7mm	552,90	510,30
8mm	629,10	580,70
9mm	705,30	651,00
10mm	786,90	726,40
11mm	863,10	796,70
12mm	939,30	867,10
13mm	1.015,50	937,40
14mm	1.091,70	1.007,70
15mm	1.167,90	1.078,10
16mm	1.244,10	1.148,40
18mm	1.396,50	1.289,10
20mm	1.573,90	1.452,80
25mm	1.954,90	1.804,50
30mm	2.335,80	2.156,20
40mm	3.097,80	2.859,50
50mm	3.859,70	3.562,80

Foam EVA 250kg/m ³ 1800x900mm - white + anthracite		
thickness 	Price	
	1 - 9,99m ²	10 - 99,99m ²
1mm	105,60	97,40
2mm	191,60	176,90
3mm	277,70	256,30
4mm	363,70	335,70
5mm	449,80	415,20
6mm	535,80	494,60
7mm	621,90	574,00
8mm	707,90	653,40
9mm	794,00	732,90
10mm	885,50	817,40
11mm	971,60	896,80
12mm	1.057,60	976,30
13mm	1.143,70	1.055,70
14mm	1.229,70	1.135,10
15mm	1.315,80	1.214,50
16mm	1.401,80	1.294,00
18mm	1.573,90	1.452,80
20mm	1.771,00	1.634,80
25mm	2.201,30	2.031,90
30mm	2.631,50	2.429,10
40mm	3.492,00	3.223,40

Foam EVA 250kg/m ³ 1800x900mm - colored		
thickness 	Price	
	1 - 9,99m ²	10 - 99,99m ²
1mm	114,00	105,30
2mm	208,60	192,50
3mm	303,10	279,80
4mm	397,60	367,00
5mm	492,20	454,30
6mm	586,70	541,60
7mm	681,20	628,80
8mm	775,80	716,10
9mm	870,30	803,30
10mm	970,30	895,70
11mm	1.064,80	982,90
12mm	1.159,40	1.070,20
13mm	1.253,90	1.157,50
14mm	1.348,40	1.244,70
15mm	1.443,00	1.332,00
16mm	1.537,50	1.419,20
18mm	1.726,60	1.593,80
20mm	1.940,60	1.791,40
25mm	2.413,30	2.227,70
30mm	2.885,90	2.664,00
40mm	3.831,30	3.536,60

Foam EVA 300kg/m ³ 1700x850mm - white + anthracite		
thickness 	Price	
	1 - 9,99m ²	10 - 99,99m ²
1mm	105,00	96,90
2mm	190,50	175,80
3mm	276,00	254,80
4mm	361,50	333,70
5mm	447,00	412,60
6mm	532,50	491,50
7mm	618,00	570,40
8mm	703,50	649,40
9mm	789,00	728,30
10mm	880,00	812,30
11mm	965,50	891,20
12mm	1.051,00	970,10
13mm	1.136,50	1.049,00
14mm	1.222,00	1.128,00
15mm	1.307,50	1.206,90
16mm	1.393,00	1.285,80
18mm	1.56400	1.443,70
20mm	1.760,00	1.624,60
25mm	2.187,40	2.019,20
30mm	2.614,90	2.413,80
40mm	3.469,90	3.203,00

Foam EVA 300kg/m ³ 1700x850mm - colored		
thickness 	Price	
	1 - 9,99m ²	10 - 99,99m ²
1mm	113,40	104,70
2mm	207,30	191,40
3mm	301,20	278,00
4mm	395,10	364,70
5mm	489,00	451,40
6mm	582,90	538,10
7mm	676,80	624,70
8mm	770,70	711,40
9mm	864,60	798,10
10mm	964,00	889,80
11mm	1.057,90	976,50
12mm	1.151,80	1.063,20
13mm	1.245,70	1.149,90
14mm	1.339,60	1.236,50
15mm	1.433,50	1.323,20
16mm	1.527,40	1.409,90
18mm	1.715,20	1.583,30
20mm	1.928,00	1.779,70
25mm	2.397,50	2.213,10
30mm	2.867,00	2.646,40
40mm	3.806,00	3.513,20

RUBBER SHEETS

REGRANULATE

The recycled rubber plate is suitable for the construction and general industry field for noise, load and vibration damping. It is used in the industrial halls as:

- floor to compensate for unevenness
- cable translation
- pad for pressing and casting molds
- pallet pad to prevent movement
- Abrasion pad between products

Single-layer rubber granulate sheets are made of crushed tire rubber and are bonded with polyurethane adhesive. The material characteristics do not change even under conditions of maximum effort.

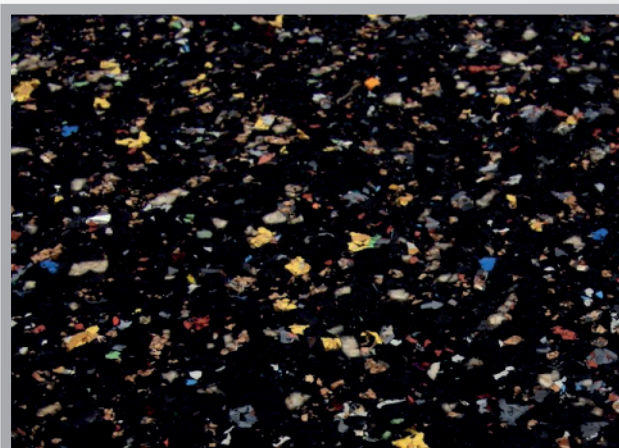
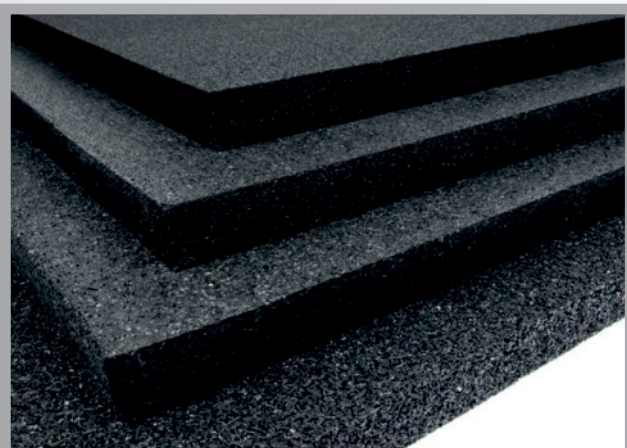

ADIREG - regranulate	Price		
 thickness X dimension 	0 - 12,49m ²	12,5 - 99,99m ²	100 -m ²
tl. 3mm x 1.250x20.000mm	104,53	87,11	80,41
tl. 4mm x 1.250x15.000mm	139,38	116,15	107,21
tl. 5mm x 1.250x12.000mm	146,22	121,85	112,48
tl. 6mm x 1.250x10.000mm	151,20	126,00	116,31
tl. 8mm x 1.250x10.000mm	200,36	166,96	154,12
tl. 10mm x 1.250x6.000mm	240,80	200,67	185,23
tl. 12mm x 1.250x6.000mm	291,20	242,67	224,00
tl. 15mm x 1.150x2.300mm	342,22	285,19	263,25
tl. 20mm x 1.150x2.300mm	494,67	412,22	380,51
tl. 25mm x 1.000x2.000mm	935,20	779,33	719,38
tl. 30mm x 1.000x2.000mm	1.074,08	895,07	826,22
tl. 40mm x 1.000x2.000mm	1.551,20	1.292,67	1.193,23
tl. 50mm x 1.000x2.000mm	1.826,72	1.522,27	1.405,17
tl. 60mm x 1.000x2.000mm	2.103,36	1.752,80	1.617,97
tl. 64mm x 1.000x2.000mm	2.213,12	1.844,27	1.702,40



RUBBER SHEETS

REGRANULATE



...Immediate sealing effect

Regranulated PUZZLE sheets.

Packaging: Wooden pallets 1000x1000mm. If necessary, we will calculate the shipping according to the weight of the shipment and the place of delivery.

For extra colors the minimum order quantity is 50m². Standard colors with admixture 10% EPDM are in stock.

Standard colors:

 Red RED 000 RAL 3016	 Green MAY GREEN 410 RAL 6017	 Grey LIGHT GREY 380 RAL 7035
 Blue SKY BLUE 180 RAL 5015	 Yellow YELLOW 200 RAL 1012	





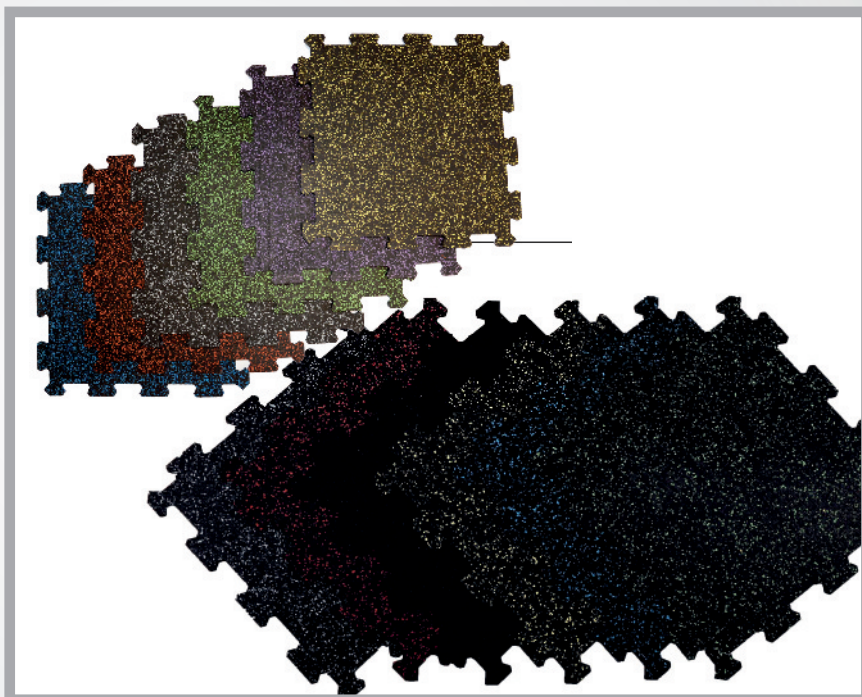
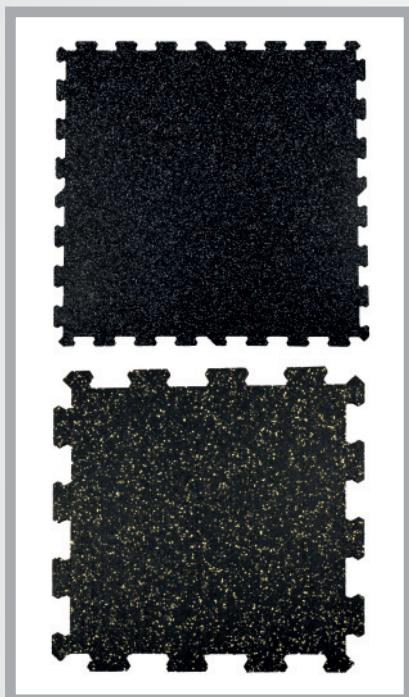



Příplatkové barvy:









 Orange ORANGE 550 RAL 2004	 Sand yellow EARTH YELLOW 570 RAL 1011	 Turquoise blue TURQUOISE BLUE 540 RAL 5018
 Blue TEAL 580 RAL 5024	 Dark blue CAPRI BLUE 150 RAL 5019	 White PEARL 290 RAL 1013
 Pink ROSE 750 RAL 3017	 Beige BEIGE 210 RAL 1001	 Dark blue RAINBOW BLUE 590 RAL 5017
 Brown BROWN 280 RAL 8024	 Purple PURPLE 340 RAL 4005	 Grass green RAINBOW GREEN 560 RAL 6025
 Slate GREY RAL 7015	 EGG SHELL RAL 1015	 BLACK RAL 9004
 RESEDA GREEN RAL 6011	 Platinum GREEN RAL 6000	 Signal GREEN RAL 6032
 BLUE GREY 100 RAL 5014		



RUBBER SHEETS

REGRANULATE

Regranulate - PUZZLE BIG		Price			
BLACK	 Size 	0 - 9 ks	10 - 49 ks	50 - 99 ks	od 100 ks
ADIFLOOR PUZZLE ADI 1050	956x956x8mm	449,87	415,26	385,60	359,89
ADIFLOOR PUZZLE ADI 1050	956x956x10mm	518,93	479,02	444,80	415,15
ADIFLOOR PUZZLE ADI 1050	956x956x16mm	804,53	742,65	689,60	643,63
10% EPDM standard	 Size 	0 - 9 ks	10 - 49 ks	50 - 99 ks	od 100 ks
ADIFLOOR PUZZLE ADI 1050	956x956x8mm	567,47	523,82	486,40	453,97
ADIFLOOR PUZZLE ADI 1050	956x956x10mm	666,40	615,14	571,20	533,12
ADIFLOOR PUZZLE ADI 1050	956x956x16mm	1.039,73	959,75	891,20	831,79
20% EPDM standard	 Size 	0 - 9 ks	10 - 49 ks	50 - 99 ks	od 100 ks
ADIFLOOR PUZZLE ADI 1050	956x956x8mm	688,80	635,82	590,40	551,04
ADIFLOOR PUZZLE ADI 1050	956x956x10mm	817,60	754,71	700,80	654,08
ADIFLOOR PUZZLE ADI 1050	956x956x16mm	1.282,40	1.183,75	1.099,20	1.025,92
40% EPDM standard	 Size 	0 - 9 ks	10 - 49 ks	50 - 99 ks	od 100 ks
ADIFLOOR PUZZLE ADI 1050	956x956x8mm	938,93	866,71	804,80	751,15
ADIFLOOR PUZZLE ADI 1050	956x956x10mm	1.129,33	1.042,46	968,00	903,47
ADIFLOOR PUZZLE ADI 1050	956x956x16mm	1.780,80	1.643,82	1.526,40	1.424,64

Regranulate - PUZZLE SMALL		Price			
BLACK	 Size 	0 - 9 ks	10 - 49 ks	50 - 99 ks	od 100 ks
ADIFLOOR PUZZLE ADI 1050	478x478x8mm	117,60	108,55	100,80	94,08
ADIFLOOR PUZZLE ADI 1050	478x478x10mm	136,27	125,78	116,80	109,01
ADIFLOOR PUZZLE ADI 1050	478x478x16mm	207,20	191,26	177,60	165,76
10% EPDM standard	 Size 	0 - 9 ks	10 - 49 ks	50 - 99 ks	od 100 ks
ADIFLOOR PUZZLE ADI 1050	478x478x8mm	147,47	136,12	126,40	117,97
ADIFLOOR PUZZLE ADI 1050	478x478x10mm	171,73	158,52	147,20	137,39
ADIFLOOR PUZZLE ADI 1050	478x478x16mm	265,07	244,68	227,20	212,05
20% EPDM standard	 Size 	0 - 9 ks	10 - 49 ks	50 - 99 ks	od 100 ks
ADIFLOOR PUZZLE ADI 1050	478x478x8mm	179,20	165,42	153,60	143,36
ADIFLOOR PUZZLE ADI 1050	478x478x10mm	210,93	194,71	180,80	168,75
ADIFLOOR PUZZLE ADI 1050	478x478x16mm	326,67	301,54	280,00	261,33
40% EPDM standard	 Size 	0 - 9 ks	10 - 49 ks	50 - 99 ks	od 100 ks
ADIFLOOR PUZZLE ADI 1050	478x478x8mm	240,80	222,28	206,40	192,64
ADIFLOOR PUZZLE ADI 1050	478x478x10mm	287,47	265,35	246,40	229,97
ADIFLOOR PUZZLE ADI 1050	478x478x16mm	451,73	416,98	387,20	361,39

RUBBER SHEETS

REGRANULATE



...Immediate sealing effect

Sheets and components for playgrounds

The stated sizes are approximate, the sheets are subject to shrinkage of approximately 2%. All sheets for playgrounds and elastic sheets with a 15mm grid can also be produced in sizes 400x400mm, 500x1000mm, 600x600mm and 600x1200mm. Prices per 1m² correspond to prices for size 500x500mm. Products can also be ordered in anthracite gray and dark brown - at the price of green.

Rubber sheets - regranulate					Fall height according to EN 1177*	Price				
no.	Product	size	code ADITEG	color		0 - 9 m ²	10 - 49 m ²	50 - 99 m ²	od 100 m ²	
1	Playground sheet smooth thickness 20mm	500x500x20 smooth	ADI1-20-0300-00	● black	0,60	634,00	592,00	555,00	523,00	
			ADI1-20-0301-00	● red		685,00	639,00	599,00	564,00	
			ADI1-20-0302-00	● green		733,00	684,00	651,00	604,00	
	Playground sheet thickness 25mm and 30mm with pressed-in holes	500x500x25 raster 15mm	ADI1-25-0300-15	● black	0,90	634,00	592,00	555,00	523,00	
			ADI1-25-0301-15	● red		685,00	639,00	599,00	564,00	
			ADI1-25-0302-15	● green		733,00	684,00	641,00	604,00	
		1000x1000x25 raster 15mm	ADI3-25-0300-15	● black	0,90	634,00	592,00	555,00	523,00	
			ADI3-25-0301-15	● red		685,00	639,00	599,00	564,00	
			ADI3-25-0302-15	● green		733,00	684,00	641,00	604,00	
	500x500x30 smooth	500x500x30 smooth	ADI1-30-0300-00	● black	0,90	886,00	827,00	775,00	730,00	
			ADI1-30-0301-00	● red		960,00	896,00	840,00	791,00	
			ADI1-30-0302-00	● green		1.022,00	954,00	895,00	842,00	
	1000x1000x30 smooth	1000x1000x30 smooth	ADI3-30-0300-00	● black	0,90	886,00	827,00	775,00	730,00	
			ADI3-30-0301-00	● red		960,00	896,00	840,00	791,00	
			ADI3-30-0302-00	● green		1.022,00	954,00	895,00	842,00	
	500x500x30 raster 15mm	500x500x30 raster 15mm	ADI1-30-0300-15	● black	1,10	784,00	731,00	686,00	645,00	
			ADI1-30-0301-15	● red		837,00	781,00	732,00	689,00	
			ADI1-30-0302-15	● green		895,00	836,00	783,00	737,00	
	1000x1000x30 raster 15mm	1000x1000x30 raster 15mm	ADI3-30-0300-15	● black	1,10	784,00	731,00	686,00	645,00	
			ADI3-30-0301-15	● red		837,00	781,00	732,00	689,00	
			ADI3-30-0302-15	● green		895,00	836,00	783,00	737,00	
500x500x30 raster 18mm	500x500x30 raster 18mm	ADI1-30-0300-18	● black	1,00	681,00	636,00	596,00	561,00		
		ADI1-30-0301-18	● red		730,00	682,00	639,00	602,00		
		ADI1-30-0302-18	● green		773,00	722,00	677,00	637,00		
2	Playground sheet thickness 40mm with pressed-in holes	500x500x40 raster 15mm	ADI1-40-0300-15	● black	1,30	1.070,00	999,00	937,00	882,00	
			ADI1-40-0301-15	● red		1.129,00	1.054,00	988,00	930,00	
			ADI1-40-0302-15	● green		1.187,00	1.108,00	1.039,00	978,00	
		1000x1000x40 raster 15mm	1000x1000x40 raster 15mm	ADI3-40-0300-15	● black	1,30	1.070,00	999,00	937,00	882,00
				ADI3-40-0301-15	● red		1.129,00	1.054,00	988,00	930,00
				ADI3-40-0302-15	● green		1.187,00	1.108,00	1.039,00	978,00
		500x500x40 raster 28mm	500x500x40 raster 28mm	ADI1-40-0300-28	● black	1,30	846,00	790,00	740,00	697,00
				ADI1-40-0301-28	● red		891,00	832,00	780,00	734,00
				ADI1-40-0302-28	● green		959,00	895,00	839,00	790,00
	1000x1000x40 raster 28mm	1000x1000x40 raster 28mm	ADI3-40-0300-28	● black	1,30	846,00	790,00	740,00	697,00	
			ADI3-40-0301-28	● red		891,00	832,00	780,00	734,00	
			ADI3-40-0302-28	● green		959,00	895,00	839,00	790,00	

Rubber sheets - regranulate					Fall height according to EN 1177*	Price					
no	Product	 size	code ADITEG	color		0 - 9 m ²	10 - 49 m ²	50 - 99 m ²	od 100 m ²		
3	Playground sheet Thickness 45mm with pressed-in holes	500x500x45 raster 15mm	AD11-45-0300-15	● black	1,50	1.187,00	1.108,00	1.039,00	978,00		
			AD11-45-0301-15	● red		1.265,00	1.181,00	1.107,00	1.042,00		
			AD11-45-0302-15	● green		1.275,00	1.190,00	1.116,00	1.050,00		
		1000x1000x45 raster15mm	AD13-45-0300-15	● black	1,50	1.187,00	1.108,00	1.039,00	978,00		
			AD13-45-0301-15	● red		1.265,00	1.181,00	1.107,00	1.042,00		
			AD13-45-0302-15	● green		1.275,00	1.190,00	1.116,00	1.050,00		
		500x500x45 raster BIG	AD11-45-0300-25 BIG	● black	1,40	1.214,00	1.133,00	1.063,00	1.000,00		
			AD11-45-0301-25 BIG	● red		1.316,00	1.228,00	1.151,00	1.083,00		
			AD11-45-0302-25 BIG	● green		1.390,00	1.297,00	1.216,00	1.144,00		
		500x500x45 raster 28mm	AD11-45-0300-28	● black	1,50	947,00	884,00	829,00	780,00		
			AD11-45-0301-28	● red		987,00	922,00	864,00	813,00		
			AD11-45-0302-28	● green		1.037,00	968,00	907,00	854,00		
		1000x1000x45 raster 28mm	AD13-45-0300-28	● black	1,50	947,00	884,00	829,00	780,00		
			AD13-45-0301-28	● red		987,00	922,00	864,00	813,00		
			AD13-45-0302-28	● green		1.037,00	968,00	907,00	854,00		
		4	Playground sheet thickness 50mm with pressed-in holes	500x500x50 raster15mm	AD11-50-0300-15	● black	1,40	1.246,00	1.163,00	1.090,00	1.026,00
					AD11-50-0301-15	● red		1.304,00	1.217,00	1.141,00	1.074,00
					AD11-50-0302-15	● green		1.362,00	1.272,00	1.192,00	1.122,00
1000x1000x50 raster15mm	AD13-50-0300-15			● black	1,40	1.246,00	1.163,00	1.090,00	1.026,00		
	AD13-50-0301-15			● red		1.304,00	1.217,00	1.141,00	1.074,00		
	AD13-50-0302-15			● green		1.362,00	1.272,00	1.192,00	1.122,00		
500x500x50 rasterBIG	AD11-50-0300-25 BIG			● black	1,50	1.327,00	1.239,00	1.161,00	1.039,00		
	AD11-50-0301-25 BIG			● red		1.438,00	1.342,00	1.258,00	1.184,00		
	AD11-50-0302-25 BIG			● green		1.518,00	1.417,00	1.328,00	1.250,00		
500x500x50 raster 28mm	AD11-50-0300-28			● black	1,70	1.096,00	1.023,00	959,00	902,00		
	AD11-50-0301-28			● red		1.201,00	1.121,00	1.051,00	989,00		
	AD11-50-0302-28			● green		1.270,00	1.186,00	1.111,00	1.046,00		
1000x1000x50 raster 28mm	AD13-50-0300-28			● black	1,70	1.109,00	1.035,00	971,00	914,00		
	AD13-50-0301-28			● red		1.201,00	1.121,00	1.051,00	989,00		
	AD13-50-0302-28			● green		1.270,00	1.186,00	1.111,00	1.046,00		
5	Playground sheet thickness 55mm, 65mm and 75mm with pressed-in holes			500x500x55 raster15mm	AD11-55-0300-15	● black	1,50	1.436,00	1.341,00	1.257,00	1.183,00
					AD11-55-0301-15	● red		1.557,00	1.453,00	1.362,00	1.282,00
					AD11-55-0302-15	● green		1.644,00	1.534,00	1.438,00	1.354,00
		500x500x55 raster 28mm	AD11-55-0300-28	● black	1,70	1.275,00	1.190,00	1.116,00	1.050,00		
			AD11-55-0301-28	● red		1.382,00	1.290,00	1.209,00	1.138,00		
			AD11-55-0302-28	● green		1.460,00	1.362,00	1.277,00	1.202,00		
		500x500x65 raster28mm	AD11-65-0300-28	● black	1,90	1.800,00	1.680,00	1.575,00	1.482,00		
			AD11-65-0301-28	● red		1.923,00	1.795,00	1.683,00	1.584,00		
			AD11-65-0302-28	● green		1.936,00	1.807,00	1.694,00	1.594,00		
		500x500x65 raster 50mm	AD11-65-7500-50	● black	2,30	1.656,00	1.545,00	1.449,00	1.363,00		
			AD11-65-7501-50	● red		1.732,00	1.617,00	1.516,00	1.426,00		
			AD11-65-7502-50	● green		1.848,00	1.724,00	1.617,00	1.522,00		
		1000x1000x65 raster 50mm	AD13-65-7500-50	● black	2,30	1.656,00	1.545,00	1.449,00	1.363,00		
			AD13-65-7501-50	● red		1.732,00	1.616,00	1.515,00	1.426,00		
			AD13-65-7502-50	● green		1.848,00	1.725,00	1.617,00	1.522,00		
		500x500x75 raster 50mm	AD11-75-7500-50	● black	2,40	2.330,00	2.175,00	2.039,00	1.919,00		
			AD11-75-7501-50	● red		2.391,00	2.232,00	2.092,00	1.969,00		
			AD11-75-7502-50	● green		2.582,00	2.410,00	2.259,00	2.126,00		

RUBBER SHEETS

REGRANULATE



RUBBER SHEETS

Rubber sheets - regranulate					Fall height according to EN 1177*	Price				
no.	Product	size	code ADITEG	color		0 - 9 m ²	10 - 49 m ²	50 - 99 m ²	od 100 m ²	
6	Playground sheet thickness 80mm	500x500x80 raster 15mm	ADI1-80-0300-15	● black	1,70	2.254,00	2.103,00	1.972,00	1.856,00	
			ADI1-80-0301-15	● red		2.310,00	2.156,00	2.021,00	1.902,00	
			ADI1-80-0302-15	● green		2.496,00	2.330,00	2.184,00	2.056,00	
		500x500x80 raster 28mm	ADI1-80-0300-28	● black	1,90	2.077,00	1.939,00	1.818,00	1.711,00	
			ADI1-80-0301-28	● red		2.219,00	2.071,00	1.941,00	1.827,00	
			ADI1-80-0302-28	● green		2.332,00	2.176,00	2.040,00	1.920,00	
		500x500x80 raster 50mm	ADI1-80-0300-50	● black	2,40	1.846,00	1.723,00	1.615,00	1.520,00	
			ADI1-80-0301-50	● red		1.945,00	1.815,00	1.702,00	1.602,00	
			ADI1-80-0302-50	● green		2.017,00	1.882,00	1.762,00	1.661,00	
	1000x1000x80 raster 50mm	ADI3-80-0300-50	● black	2,40	1.846,00	1.723,00	1.615,00	1.520,00		
		ADI3-80-0301-50	● red		1.945,00	1.815,00	1.702,00	1.602,00		
		ADI3-80-0302-50	● green		2.017,00	1.882,00	1.765,00	1.661,00		
7	Playground sheet thickness 90mm	500x500x90 raster BIG	ADI1-90-0300-25 BIG	● black	1,70	3.229,00	3.014,00	2.826,00	2.660,00	
			ADI1-90-0301-25 BIG	● red		3.424,00	3.196,00	2.993,00	2.820,00	
			ADI1-90-0302-25 BIG	● green		3.580,00	3.341,00	3.132,00	2.948,00	
		500x500x90 raster 28mm	ADI1-90-0300-28	● black	2,20	2.982,00	2.783,00	2.609,00	2.455,00	
			ADI1-90-0301-28	● red		3.162,00	2.951,00	2.767,00	2.604,00	
			ADI1-90-0302-28	● green		3.309,00	3.088,00	2.895,00	2.725,00	
8	Playground sheet thickness 100mm	500x500x100 raster 28mm	ADI1-00-0300-28	● black	2,00	2.769,00	2.584,00	2.423,00	2.280,00	
			ADI1-00-0301-28	● red		2.919,00	2.725,00	2.554,00	2.404,00	
			ADI1-00-0302-28	● green		3.031,00	2.829,00	2.652,00	2.496,00	
		500x500x100 raster 50mm	ADI1-00-0300-50	● black	2,80	2.307,00	2.153,00	2.019,00	1.900,00	
			ADI1-00-0301-50	● red		2.433,00	2.271,00	2.129,00	2.003,00	
			ADI1-00-0302-50	● green		2.524,00	2.355,00	2.208,00	2.078,00	
		500x500x100 raster 75mm	ADI1-00-0300-75	● black	3,00	1.927,00	1.798,00	1.686,00	1.587,00	
			ADI1-00-0301-75	● red		1.989,00	1.856,00	1.740,00	1.638,00	
			ADI1-00-0302-75	● green		2.063,00	1.925,00	1.805,00	1.699,00	
9	Edge plate thickness 30mm	500x500x30 smooth	ADI-K1-30-0300-00	● black		1.265,00	1.181,00	1.107,00	1.042,00	
			ADI-K1-30-0301-00	● red		1.313,00	1.226,00	1.149,00	1.081,00	
			ADI-K1-30-0302-00	● green		1.357,00	1.267,00	1.188,00	1.118,00	
	Corner plate thickness 30mm	500x500x30 smooth	ADI-R1-30-0300-00	● black		1.226,00	1.144,00	1.073,00	1.010,00	
			ADI-R1-30-0301-00	● red		1.270,00	1.186,00	1.111,00	1.046,00	
			ADI-R1-30-0302-00	● green		1.313,00	1.226,00	1.149,00	1.081,00	
	Half board thickness 30mm	500x250x30 raster 15mm	ADI1/2-30-0300-15	● black		900,00	840,00	788,00	742,00	
			ADI1/2-30-0301-15	● red		963,00	899,00	842,00	793,00	
			ADI1/2-30-0302-15	● green		1.030,00	962,00	901,00	848,00	
	10	Edge plate thickness 40mm	500x500x40 smooth	ADI-K1-40-0300-00	● black		1.543,00	1.440,00	1.350,00	1.270,00
				ADI-K1-40-0301-00	● red		1.596,00	1.490,00	1.396,00	1.314,00
				ADI-K1-40-0302-00	● green		1.650,00	1.540,00	1.444,00	1.359,00
Corner plate thickness 40mm		500x250x40 smooth	ADI-R1-40-0300-00	● black		1.455,00	1.358,00	1.273,00	1.198,00	
			ADI-R1-40-0301-00	● red		1.508,00	1.407,00	1.319,00	1.242,00	
			ADI-R1-40-0302-00	● green		1.557,00	1.453,00	1.362,00	1.282,00	
Half board thickness 40mm		500x250x40 raster 28mm	ADI1/2-40-0300-28	● black		973,00	908,00	851,00	801,00	
			ADI1/2-40-0301-28	● red		1.025,00	957,00	897,00	844,00	
			ADI1/2-40-0302-28	● green		1.103,00	1.029,00	965,00	908,00	

Rubber sheets - regranulate					Price			
no.	Product	size	code ADITEG	color	0 - 9 m ²	10 - 49 m ²	50 - 99 m ²	od 100 m ²
11	Edge plate Thickness 45mm	500x500x45 smooth	ADI-K1-45-0300-00	● black	1.791,00	1.671,00	1.567,00	1.475,00
			ADI-K1-45-0301-00	● red	1.854,00	1.731,00	1.622,00	1.527,00
			ADI-K1-45-0302-00	● green	1.913,00	1.785,00	1.673,00	1.575,00
	Corner plate Thickness 45mm	500x500x45 smooth	ADI-R1-45-0300-00	● black	1.709,00	1.595,00	1.495,00	1.407,00
			ADI-R1-45-0301-00	● red	1.765,00	1.647,00	1.544,00	1.453,00
			ADI-R1-45-0302-00	● green	1.823,00	1.701,00	1.595,00	1.501,00
	Half board Thickness 45mm	500x250x45 raster28mm	ADI1/2-45-0300-28	● black	1.090,00	1.017,00	954,00	898,00
			ADI1/2-45-0301-28	● red	1.137,00	1.061,00	995,00	936,00
			ADI1/2-45-0302-28	● green	1.191,00	1.112,00	1.042,00	981,00
12	Edge plate thickness 50mm	500x500x50 smooth	ADI-K1-50-0300-00	● black	1.874,00	1.749,00	1.639,00	1.543,00
			ADI-K1-50-0301-00	● red	1.936,00	1.807,00	1.694,00	1.594,00
			ADI-K1-50-0302-00	● green	1.999,00	1.866,00	1.750,00	1.647,00
	Corner plate thickness 50mm	500x500x50 smooth	ADI-R1-50-0300-00	● black	1.709,00	1.595,00	1.495,00	1.407,00
			ADI-R1-50-0301-00	● red	1.766,00	1.648,00	1.545,00	1.454,00
			ADI-R1-50-0302-00	● green	1.824,00	1.703,00	1.596,00	1.502,00
	Half board thickness 50mm	500x250x50 raster 28mm	ADI1/2-50-0300-28	● black	1.277,00	1.192,00	1.117,00	1.051,00
			ADI1/2-50-0301-28	● red	1.380,00	1.288,00	1.208,00	1.137,00
			ADI1/2-50-0302-28	● green	1.461,00	1.364,00	1.278,00	1.203,00
13	Edge plate thickness 55mm	500x500x55 smooth	ADI-K1-55-0300-00	● black	2.082,00	1.944,00	1.822,00	1.715,00
			ADI-K1-55-0301-00	● red	2.155,00	2.011,00	1.886,00	1.775,00
			ADI-K1-55-0302-00	● green	2.224,00	2.076,00	1.946,00	1.831,00
	Corner plate Thickness 45mm	500x500x55 smooth	ADI-R1-55-0300-00	● black	1.976,00	1.844,00	1.729,00	1.627,00
			ADI-R1-55-0301-00	● red	2.044,00	1.907,00	1.788,00	1.683,00
			ADI-R1-55-0302-00	● green	2.112,00	1.972,00	1.848,00	1.740,00
	Half board thickness 55mm	500x250x55 raster 28mm	ADI1/2-55-0300-28	● black	1.466,00	1.368,00	1.283,00	1.207,00
			ADI1/2-55-0301-28	● red	1.588,00	1.482,00	1.390,00	1.308,00
			ADI1/2-55-0302-28	● green	1.684,00	1.572,00	1.474,00	1.387,00
14	Edge plate thickness 65mm	500x500x65 smooth	ADI-K1-65-0300-00	● black	2.333,00	2.178,00	2.042,00	1.922,00
			ADI-K1-65-0301-00	● red	2.121,00	1.980,00	1.856,00	1.747,00
			ADI-K1-65-0302-00	● green	2.195,00	2.049,00	1.921,00	1.808,00
	Corner plate thickness 65mm	500x500x65 smooth	ADI-R1-65-0300-00	● black	2.121,00	1.980,00	1.856,00	1.747,00
			ADI-R1-65-0301-00	● red	2.195,00	2.049,00	1.921,00	1.808,00
			ADI-R1-65-0302-00	● green	2.225,00	2.077,00	1.947,00	1.832,00
	Half board thickness 65mm	500x250x65 raster 28mm	ADI1/2-65-0300-28	● black	2.071,00	1.933,00	1.812,00	1.705,00
			ADI1/2-65-0301-28	● red	2.211,00	2.064,00	1.935,00	1.821,00
			ADI1/2-65-0302-28	● green	2.226,00	2.078,00	1.948,00	1.833,00
Corner plate thickness 65mm	500x500x65 raster 50mm	ADI1/2-65-0300-50	● black	1.905,00	1.778,00	1.667,00	1.569,00	
		ADI1/2-65-0301-50	● red	1.990,00	1.858,00	1.742,00	1.639,00	
		ADI1/2-65-0302-50	● green	2.125,00	1.984,00	1.860,00	1.750,00	
15	Edge plate thickness 80mm	500x500x80 smooth	ADI-K1-80-0300-00	● black	2.787,00	2.601,00	2.439,00	2.295,00
			ADI-K1-80-0301-00	● red	2.886,00	2.693,00	2.525,00	2.376,00
			ADI-K1-80-0302-00	● green	2.982,00	2.783,00	2.609,00	2.455,00
	Corner plate thickness 80mm	500x500x80 hladká	ADI-R1-80-0300-00	● black	2.394,00	2.234,00	2.095,00	1.971,00
			ADI-R1-80-0301-00	● red	2.477,00	2.31200	2.167,00	2.040,00
			ADI-R1-80-0302-00	● green	2.544,00	2.375,00	2.226,00	2.095,00
	Half board thickness 80mm	500x250x80 raster 50mm	ADI1/2-80-0300-50	● black	1.998,00	1.865,00	1.748,00	1.646,00
			ADI1/2-80-0301-50	● red	2.104,00	1.964,00	1.841,00	1.733,00
			ADI1/2-80-0302-50	● green	2.182,00	2.037,00	1.910,00	1.797,00

RUBBER SHEETS

REGRANULATE



Rubber sheets - regranulate					Price			
no.	Product	size	code ADITEG	color	0 - 9 m ²	10 - 49 m ²	50 - 99 m ²	od 100 m ²
16	Edge plate thickness 90mm	500x500x90 smooth	ADI-K1-90-0300-00	● black	3.017,00	2.816,00	2.640,00	2.484,00
			ADI-K1-90-0301-00	● red	3.118,00	2.910,00	2.728,00	2.568,00
			ADI-K1-90-0302-00	● green	3.226,00	3.011,00	2.822,00	2.656,00
	Corner plate thickness 90mm	500x500x90 smooth	ADI-R1-90-0300-00	● black	2.496,00	2.330,00	2.184,00	2.056,00
			ADI-R1-90-0301-00	● red	2.582,00	2.410,00	2.259,00	2.126,00
			ADI-R1-90-0302-00	● green	2.672,00	2.493,00	2.338,00	2.200,00
17	Edge plate thickness 100mm	500x500x100 smooth	ADI-K1-00-0300-00	● black	3.328,00	3.106,00	2.912,00	2.741,00
			ADI-K1-00-0301-00	● red	3.445,00	3.215,00	3.014,00	2.837,00
			ADI-K1-00-0302-00	● green	3.562,00	3.324,00	3.116,00	2.933,00
	Corner plate thickness 100mm	500x500x100 smooth	ADI-R1-00-0300-00	● black	2.870,00	2.679,00	2.511,00	2.364,00
			ADI-R1-00-0301-00	● red	2.973,00	2.774,00	2.601,00	2.448,00
			ADI-R1-00-0302-00	● green	3.071,00	2.866,00	2.687,00	2.529,00
	Half board thickness 100mm	500x250x100 raster 75mm	ADI1/2-00-0300-75	● black	2.216,00	2.068,00	1.939,00	1.825,00
			ADI1/2-00-0301-75	● red	2.286,00	2.134,00	2.000,00	1.883,00
			ADI1/2-00-0302-75	● green	2.372,00	2.214,00	2.075,00	1.953,00
18	Ramp for playground sheets	750x300x20	ADIN-20-0300-NA	● black	250,00	233,00	219,00	206,00
			ADIN-20-0301-NA	● red	262,00	245,00	229,00	216,00
			ADIN-20-0302-NA	● green	274,00	256,00	240,00	226,00
	750x300x25	ADIN-25-0300-NA	● black	300,00	280,00	262,00	247,00	
		ADIN-25-0301-NA	● red	315,00	294,00	275,00	259,00	
		ADIN-25-0302-NA	● green	329,00	307,00	288,00	271,00	
	750x300x30	ADIN-30-0300-NA	● black	350,00	326,00	306,00	288,00	
		ADIN-30-0301-NA	● red	367,00	342,00	321,00	302,00	
		ADIN-30-0302-NA	● green	384,00	358,00	336,00	316,00	
	750x300x35	ADIN-35-0300-NA	● black	395,00	368,00	345,00	325,00	
		ADIN-35-0301-NA	● red	414,00	386,00	362,00	341,00	
		ADIN-35-0302-NA	● green	433,00	404,00	379,00	357,00	
	750x300x40	ADIN-40-0300-NA	● black	422,00	394,00	369,00	347,00	
		ADIN-40-0301-NA	● red	445,00	415,00	389,00	366,00	
		ADIN-40-0302-NA	● green	466,00	435,00	408,00	384,00	
	750x300x45	ADIN-45-0300-NA	● black	464,00	433,00	406,00	382,00	
		ADIN-45-0301-NA	● red	489,00	457,00	428,00	406,00	
		ADIN-45-0302-NA	● green	514,00	480,00	450,00	423,00	
	750x300x50	ADIN-50-0300-NA	● black	512,00	477,00	448,00	421,00	
		ADIN-50-0301-NA	● red	539,00	503,00	472,00	444,00	
		ADIN-50-0302-NA	● green	566,00	528,00	495,00	466,00	
750x300x65	ADIN-65-0300-NA	● black	654,00	610,00	572,00	538,00		
	ADIN-65-0301-NA	● red	689,00	643,00	603,00	568,00		
	ADIN-65-0302-NA	● green	723,00	675,00	633,00	595,00		

Ruber sheets - regrunulate					Price			
no.	Product	 size	code ADITEG	color	0 - 9 m ²	10 - 49 m ²	50 - 99 m ²	od 100 m ²
19	Left corner ramp for playground sheets	750x300x20	ADIN-20-0300-RL	● black	190,00	177,00	166,00	156,00
			ADIN-20-0301-RL	● red	199,00	186,00	174,00	164,00
			ADIN-20-0302-RL	● green	208,00	194,00	182,00	171,00
		750x300x25	ADIN-25-0300-RL	● black	225,00	210,00	197,00	185,00
			ADIN-25-0301-RL	● red	236,00	220,00	206,00	194,00
			ADIN-25-0302-RL	● green	247,00	230,00	216,00	203,00
		750x300x30	ADIN-30-0300-RL	● black	280,00	261,00	245,00	230,00
			ADIN-30-0301-RL	● red	293,00	274,00	257,00	241,00
			ADIN-30-0302-RL	● green	307,00	286,00	268,00	253,00
		750x300x35	ADIN-35-0300-RL	● black	300,00	280,00	262,00	247,00
			ADIN-35-0301-RL	● red	314,00	293,00	275,00	259,00
			ADIN-35-0302-RL	● green	329,00	307,00	288,00	271,00
		750x300x40	ADIN-40-0300-RL	● black	330,00	308,00	288,00	271,00
			ADIN-40-0301-RL	● red	346,00	323,00	303,00	285,00
			ADIN-40-0302-RL	● green	362,00	338,00	316,00	298,00
		750x300x45	ADIN-45-0300-RL	● black	369,00	345,00	323,00	304,00
			ADIN-45-0301-RL	● red	388,00	362,00	339,00	319,00
			ADIN-45-0302-RL	● green	406,00	379,00	355,00	334,00
750x300x50	ADIN-50-0300-RL	● black	379,00	354,00	332,00	312,00		
	ADIN-50-0301-RL	● red	400,00	373,00	350,00	329,00		
	ADIN-50-0302-RL	● green	419,00	391,00	367,00	345,00		
750x300x65	ADIN-65-0300-RL	● black	483,00	451,00	423,00	398,00		
	ADIN-65-0301-RL	● red	510,00	476,00	446,00	420,00		
	ADIN-65-0302-RL	● green	534,00	499,00	467,00	440,00		
20	Right corner ramp for playground sheets	750x300x20	ADIN-20-0300-RP	● black	190,00	177,00	166,00	156,00
			ADIN-20-0301-RP	● red	199,00	186,00	174,00	164,00
			ADIN-20-0302-RP	● green	208,00	194,00	182,00	171,00
		750x300x25	ADIN-25-0300-RP	● black	225,00	210,00	197,00	185,00
			ADIN-25-0301-RP	● red	236,00	220,00	206,00	194,00
			ADIN-25-0302-RP	● green	247,00	230,00	216,00	203,00
		750x300x30	ADIN-30-0300-RP	● black	280,00	261,00	245,00	230,00
			ADIN-30-0301-RP	● red	293,00	274,00	257,00	241,00
			ADIN-30-0302-RP	● green	307,00	286,00	268,00	253,00
		750x300x35	ADIN-35-0300-RP	● black	300,00	280,00	262,00	247,00
			ADIN-35-0301-RP	● red	314,00	293,00	275,00	259,00
			ADIN-35-0302-RP	● green	329,00	307,00	288,00	271,00
		750x300x40	ADIN-40-0300-RP	● black	330,00	308,00	288,00	271,00
			ADIN-40-0301-RP	● red	346,00	323,00	303,00	285,00
			ADIN-40-0302-RP	● green	362,00	338,00	316,00	298,00
		750x300x45	ADIN-45-0300-RP	● black	369,00	345,00	323,00	304,00
			ADIN-45-0301-RP	● red	388,00	362,00	339,00	319,00
			ADIN-45-0302-RP	● green	406,00	379,00	355,00	334,00
750x300x50	ADIN-50-0300-RP	● black	379,00	354,00	332,00	312,00		
	ADIN-50-0301-RP	● red	400,00	373,00	350,00	329,00		
	ADIN-50-0302-RP	● green	419,00	391,00	367,00	345,00		
750x300x65	ADIN-65-0300-RP	● black	483,00	451,00	423,00	398,00		
	ADIN-65-0301-RP	● red	510,00	476,00	446,00	420,00		
	ADIN-65-0302-RP	● green	534,00	499,00	467,00	440,00		

RUBBER SHEETS

REGRANULATE



RUBBER SHEETS

Rubber sheets - regranulate					Price					
no.	Product	size	code ADITEG	color	0 - 9 m ²	10 - 49 m ²	50 - 99 m ²	od 100 m ²		
21	Elastic sheet smooth 500x500mm	500x500x20	ADI-E1-20-0300-00	● black	589,00	550,00	515,00	485,00		
			ADI-E1-20-0301-00	● red	647,00	604,00	567,00	533,00		
			ADI-E1-20-0302-00	● green	706,00	659,00	618,00	581,00		
		500x500x30	ADI-E1-30-0300-00	● black	948,00	885,00	830,00	781,00		
			ADI-E1-30-0301-00	● red	1.031,00	963,00	903,00	849,00		
			ADI-E1-30-0302-00	● green	1.065,00	994,00	932,00	877,00		
		500x500x40	ADI-E1-40-0300-00	● black	1.182,00	1.103,00	1.034,00	973,00		
			ADI-E1-40-0301-00	● red	1.270,00	1.186,00	1.111,00	1.046,00		
			ADI-E1-40-0302-00	● green	1.329,00	1.240,00	1.163,00	1.094,00		
		500x500x50	ADI-E1-50-0300-00	● black	1.482,00	1.383,00	1.297,00	1.220,00		
			ADI-E1-50-0301-00	● red	1.548,00	1.445,00	1.354,00	1.275,00		
			ADI-E1-50-0302-00	● green	1.611,00	1.504,00	1.410,00	1.327,00		
22	Elastic sheet smooth 1000x1000mm	1000x1000x15	ADI-E3-15-0300-00	● black	496,00	463,00	434,00	408,00		
			ADI-E3-15-0301-00	● red	546,00	510,00	478,00	450,00		
			ADI-E3-15-0302-00	● green	595,00	555,00	520,00	490,00		
		1000x1000x20	ADI-E3-20-0300-00	● black	589,00	550,00	515,00	485,00		
			ADI-E3-20-0301-00	● red	647,00	604,00	567,00	533,00		
			ADI-E3-20-0302-00	● green	706,00	659,00	618,00	581,00		
		1000x1000x30	ADI-E3-30-0300-00	● black	948,00	885,00	830,00	781,00		
			ADI-E3-30-0301-00	● red	1.032,00	963,00	903,00	849,00		
			ADI-E3-30-0302-00	● green	1.065,00	994,00	932,00	877,00		
		1000x1000x40	ADI-E3-40-0300-00	● black	1.182,00	1.103,00	1.034,00	973,00		
			ADI-E3-40-0301-00	● red	1.270,00	1.186,00	1.111,00	1.046,00		
			ADI-E3-40-0302-00	● green	1.329,00	1.240,00	1.163,00	1.094,00		
		1000x1000x50	ADI-E3-50-0300-00	● black	1.482,00	1.383,00	1.297,00	1.220,00		
			ADI-E3-50-0301-00	● red	1.548,00	1.445,00	1.354,00	1.275,00		
			ADI-E3-50-0302-00	● green	1.611,00	1.504,00	1.410,00	1.327,00		
		23	Elastic sheet with 500x500mm raster	500x500x30	ADI-E1-30-0300-15	● black	900,00	840,00	788,00	742,00
					ADI-E1-30-0301-15	● red	993,00	926,00	869,00	817,00
					ADI-E1-30-0302-15	● green	1.022,00	954,00	895,00	842,00
500x500x40	ADI-E1-40-0300-15			● black	1.177,00	1.098,00	1.030,00	969,00		
	ADI-E1-40-0301-15			● red	1.235,00	1.153,00	1.081,00	1.017,00		
	ADI-E1-40-0302-15			● green	1.300,00	1.213,00	1.138,00	1.071,00		
500x500x50	ADI-E1-50-0300-15			● black	1.527,00	1.425,00	1.336,00	1.258,00		
	ADI-E1-50-0301-15			● red	1.139,00	1.063,00	997,00	938,00		
	ADI-E1-50-0302-15			● green	1.687,00	1.574,00	1.476,00	1.389,00		
24	Elastic sheet with 1000x1000mm raster	1000x1000x30	ADI-E3-30-0300-15	● black	900,00	840,00	788,00	742,00		
			ADI-E3-30-0301-15	● red	993,00	926,00	869,00	817,00		
			ADI-E3-30-0302-15	● green	1.022,00	954,00	895,00	842,00		
		1000x1000x40	ADI-E3-40-0300-15	● black	1.177,00	1.098,00	1.030,00	969,00		
			ADI-E3-40-0301-15	● red	1.235,00	1.153,00	1.081,00	1.017,00		
			ADI-E3-40-0302-15	● green	1.300,00	1.213,00	1.138,00	1.071,00		
		1000x1000x50	ADI-E3-50-0300-15	● black	1.527,00	1.425,00	1.336,00	1.258,00		
			ADI-E3-50-0301-15	● red	1.602,00	1.496,00	1.402,00	1.320,00		
			ADI-E3-50-0302-15	● green	1.687,00	1.574,00	1.476,00	1.389,00		

Ruber sheets - regrunulate					Price					
no	Product	size	code ADITEG	color	0 - 9 m ²	10 - 49 m ²	50 - 99 m ²	od 100 m ²		
25	Interlocking pavement	200x165x43	ADI-K1-43-9900-00	● black	1.329,00	1.241,00	1.163,00	1.095,00		
			ADI-K1-43-9901-00	● red	1.416,00	1.322,00	1.239,00	1.166,00		
			ADI-K1-43-9902-00	● green	1.504,00	1.403,00	1.316,00	1.238,00		
26	Interlocking tile	1120x1000x15	ADI-Z1-15-0300-00	● black	651,00	608,00	570,00	536,00		
			ADI-Z1-15-0301-00	● red	704,00	657,00	616,00	580,00		
			ADI-Z1-15-0302-00	● green	781,00	729,00	684,00	643,00		
		1120x1000x30	DI-Z1-30-0300-ADI-R	● black	1.094,00	1.021,00	957,00	901,00		
			DI-Z1-30-0301-ADI-R	● red	1.147,00	1.071,00	1.004,00	945,00		
			DI-Z1-30-0302-ADI-R	● green	1.199,00	1.119,00	1.049,00	987,00		
		1120x1000x43	DI-Z1-43-0300-ADI-R	● black	1.356,00	1.266,00	1.187,00	1.117,00		
			DI-Z1-43-0301-ADI-R	● red	1.408,00	1.314,00	1.232,00	1.160,00		
			DI-Z1-43-0302-ADI-R	● green	1.460,00	1.363,00	1.278,00	1.203,00		
27	Smooth sheet	1000x1000x7	ADI-H3-07-0300-00	● black	309,00	288,00	270,00	254,00		
			ADI-H3-07-0301-00	● red	395,00	369,00	346,00	326,00		
			ADI-H3-07-0302-00	● green	457,00	427,00	400,00	377,00		
		1000x1000x11	ADI-H3-11-0300-00	● black	457,00	427,00	400,00	377,00		
			ADI-H3-11-0301-00	● red	556,00	519,00	487,00	458,00		
			ADI-H3-11-0302-00	● green	637,00	594,00	557,00	524,00		
		1000x1000x15	ADI-H3-15-0300-00	● black	556,00	519,00	487,00	458,00		
			ADI-H3-15-0301-00	● red	686,00	640,00	600,00	565,00		
			ADI-H3-15-0302-00	● green	804,00	750,00	703,00	662,00		
		1000x1000x23	ADI-H3-23-0300-00	● black	847,00	791,00	741,00	698,00		
			ADI-H3-23-0301-00	● red	1.044,00	975,00	914,00	860,00		
			ADI-H3-23-0302-00	● green	1.200,00	1.120,00	1.050,00	988,00		
		28	Anti-vibration sheet	2000x1000x23	ADI-H4-07-0300-00	● black	309,00	288,00	270,00	254,00
				2000x1000x11	ADI-H4-11-0300-00	● black	457,00	427,00	400,00	377,00
					ADI-H4-15-0300-00	● black	556,00	519,00	487,00	458,00
ADI-H4-23-0300-00	● black				847,00	791,00	741,00	698,00		
ADI-H4-23-0301-00	● red				1.044,00	975,00	914,00	860,00		
29	Sandpit curb	1000x300x150	ADI11-00-0300-00	● black	1.413,00	1.319,00	1.236,00	1.164,00		
			ADI11-00-0301-00	● red	1.473,00	1.375,00	1.289,00	1.213,00		
			ADI11-00-0302-00	● green	1.556,00	1.452,00	1.361,00	1.281,00		
	Sandpit curb	1500x300x150	ADI5-00-0300-00	● black	2.313,00	2.159,00	2.024,00	1.905,00		
			ADI5-00-0301-00	● red	2.428,00	2.267,00	2.125,00	2.000,00		
			ADI5-00-0302-00	● green	2.555,00	2.384,00	2.235,00	2.104,00		
	Pavement curb	1000x250x50	ADI2-00-0300-00	● black	552,00	515,00	483,00	455,00		
			ADI2-00-0301-00	● red	592,00	553,00	518,00	488,00		
			ADI2-00-0302-00	● green	652,00	609,00	570,00	537,00		
	30	Sandpit curb	1150x300x150	ADI4-00-0300-00	● black	1.413,00	1.319,00	1.236,00	1.164,00	
				ADI4-00-0301-00	● red	1.473,00	1.375,00	1.289,00	1.213,00	
				ADI4-00-0302-00	● green	1.556,00	1.452,00	1.361,00	1.281,00	

RUBBER SHEETS

REGRANULATE



RUBBER SHEETS

Rubber sheets - regranulate					Price			
no.	Product	size	code ADITEG	color	0 - 9 m ²	10 - 49 m ²	50 - 99 m ²	od 100 m ²
31	Curb cover	1000x1000x100	ADI7-00-0300-00	● black	328,00	306,00	287,00	270,00
			ADI7-00-0301-00	● red	360,00	336,00	315,00	296,00
			ADI7-00-0302-00	● green	388,00	362,00	339,00	319,00
26	Palisade	H=400, Ø=250	ADI1-40-9900-00	● black	642,00	599,00	562,00	529,00
			ADI1-40-9901-00	● red	691,00	645,00	605,00	569,00
			ADI1-40-9902-00	● green	728,00	680,00	637,00	600,00
		H=600, Ø=250	ADI2-60-9900-00	● black	920,00	858,00	805,00	757,00
			ADI2-60-9901-00	● red	967,00	902,00	846,00	796,00
			ADI2-60-9902-00	● green	1.019,00	951,00	891,00	839,00
		H=800, Ø=250	ADI3-80-9900-00	● black	1.231,00	1.149,00	1.077,00	1.014,00
			ADI3-80-9901-00	● red	1.297,00	1.211,00	1.135,00	1.069,00
			ADI3-80-9902-00	● green	1.366,00	1.275,00	1.195,00	1.125,00
		H=1000, Ø=250	ADI4-00-9900-00	● black	1.541,00	1.438,00	1.348,00	1.269,00
			ADI4-00-9901-00	● red	1.622,00	1.514,00	1.419,00	1.336,00
			ADI4-00-9902-00	● green	1.706,00	1.592,00	1.493,00	1.405,00
	Cube	300x300x300	ADI1-30-9901-00	● red	1.513,00	1.412,00	1.324,00	1.246,00
	Curb cover	1000x400x150	ADI3-00-0301-00	● red	1.185,00	1.106,00	1.037,00	976,00
33	Additional charge for EPDM for all playground sheets and elastic sheets	všechny tloušťky	black 4021		983,00	918,00	860,00	810,00
			red 4062 - RAL 3016		1.035,00	966,00	906,00	853,00
			green 4067 - RAL 6021		1.081,00	1.009,00	946,00	890,00
			RAL 5015, RAL 1014, RAL 1002, RAL 7038, RAL 7037, RAL 7011, RAL 8025, RAL 5012, RAL 1015		1.127,00	1.052,00	986,00	928,00
			RAL 1012, RAL 6017		1.264,00	1.180,00	1.106,00	1.041,00
			RAL 6005, RAL 5010, RAL 4003, RAL 4005, RAL 2008, RAL 3017		1.403,00	1.309,00	1.227,00	1.155,00
			mix		1.196,00	1.116,00	1.046,00	985,00
			mix S		688,00	642,00	602,00	567,00
34	Sheet with grass	500x500x25	ADI1-25-5610-15		1.247,00	1.164,00	1.091,00	1.027,00
		500x500x30	ADI1-30-5610-15		1.406,00	1.312,00	1.230,00	1.158,00
35	Sheet with parquet pattern	500x500x25	ADI1-25-0300-15	● black	642,00	599,00	561,00	528,00
			ADI1-25-0301-15	● red	694,00	648,00	607,00	572,00
			ADI-25-0302-15	● green	743,00	693,00	650,00	612,00

Items, which are not a subject to customer prices					Price			
no.	Drilling and pins	name	amount	ADITEG code	0 - 9 pcs	10 - 49pcs	50 - 99 pcs	od 100 pcs
36	Drilling is possible from the min. 25mm thickness of the sheet	Drilling from 2 sides	valid for 1 piece sheets	ADI9990	Free of charge	Free of charge	Free of charge	Free of charge
		Drilling from 4 sides	valid for 1 piece sheets	ADI9991	Free of charge	Free of charge	Free of charge	Free of charge
		Connecting pin	4 pins are required for 1 piece sheets	ADI8888	2,80	2,60	2,40	2,30
		Connecting pin	4 pins are required for 1 piece sheets	ADI9999	2,80	2,60	2,40	2,30
37	Connecting elements for curb cover and sandpit curb	Connecting pin for curb cover	3 pins are required for 1 piece sheet	ADI3-SPOJ-0080	4,10	3,80	3,60	3,30
		Connecting pipe for sandpit curb OB4	length 280mm	ADI4-SPOJ-0280	108,00	101,00	95,00	89,00
		Connecting pipe for sandpit curb Ob4	length 600mm	ADI4-SPOJ-0600	112,00	105,00	98,00	93,00
		Connecting pipe for sandpit curb Ob4	length 750mm	ADI4-SPOJ-0750	118,00	110,00	104,00	97,00

Returnable packaging				Price
Pallets	size	ADITEG code	1 piece	
Wooden pallet	1200x800	ADI0301	265,00	
Wooden pallet	1000x1000	ADI0308	265,00	
Wooden pallet	1200x1100	ADI0311	298,00	
Wooden pallet	2000x1000	ADI0305	415,00	

1/ Playground sheet smooth 20mm and with pressed-in holes 25mm and 30mm



2/ Playground sheet 40mm with pressed-in holes

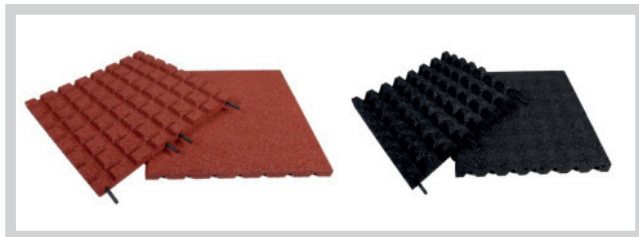

3/ Playground sheet 45mm with pressed-in holes



4/ Playground sheet 50mm with pressed-in holes

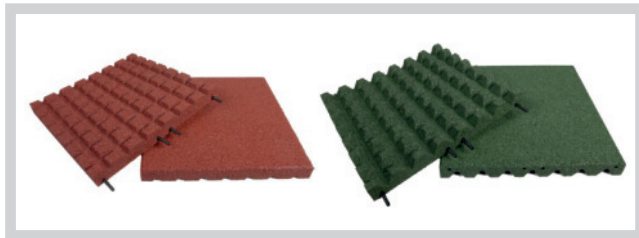

RUBBER SHEETS

REGRANULATE



5/ Playground sheet 55mm, 65mm and 75mm with pressed-in holes

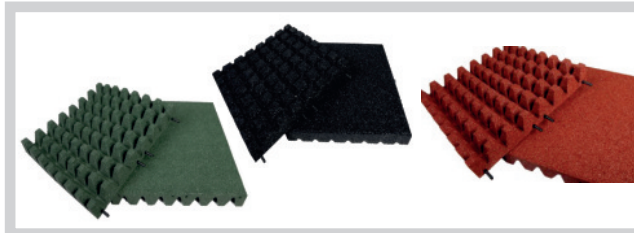

6/ Playground sheet 80mm

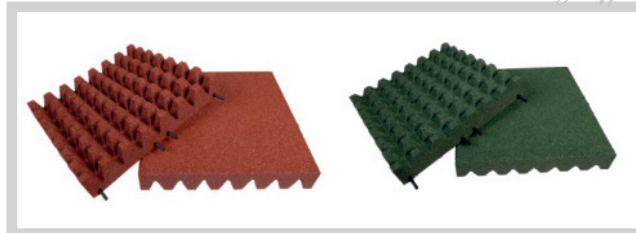

...Immediate sealing effect

7/ Playground sheet 90mm



8/ Playground sheet 100mm

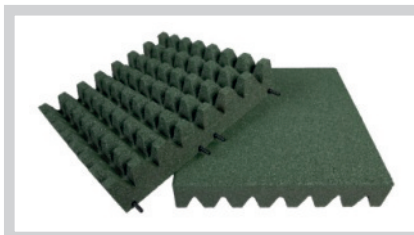

9/ Side, corner and half sheet 30mm



10/ Side, corner and half sheet 40mm



11/ Side, corner and half sheet 45mm

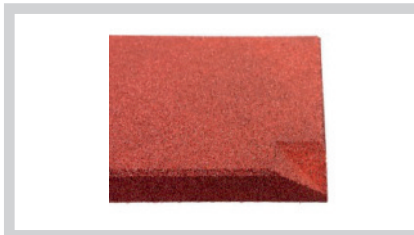

12/ Side, corner and half sheet 50mm



13/ Edge, corner and half sheet 55mm



14/ Edge, corner and half sheet 65mm



15/ Edge, corner and half sheet 80mm



16/ Edge, corner and half sheet 90mm



17/ Side, corner and half sheet 100mm

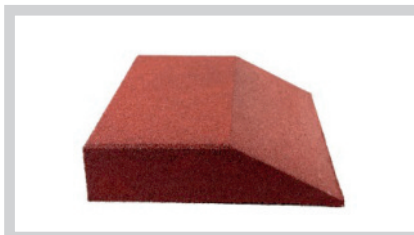

18/ Ramp for playground sheets



19/ Left corner ramp for playground sheets



20/ Right corner ramp for playground sheets



21/ Elastic smooth sheet 500x500mm

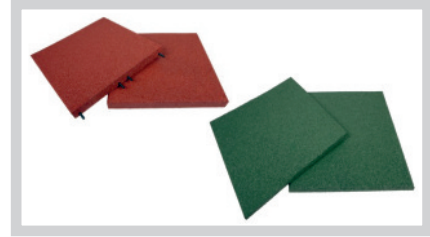

22/ Elastic smooth sheet 1000x1000mm



23/ Elastic sheet with 500x500mm raster



24/ Elastic sheet with 1000x1000mm raster



25/ Interlocking pavement



25/ Interlocking pavement



27/ Smooth sheet



28/ Anti-vibration sheet, sheet Special, stable mats



29/ Curb for sandpit and pavement



30/ Sandpit curb



31/ Pavement curb cover



32/ Palisade



33/ Extra charge for EPDM for all sheets

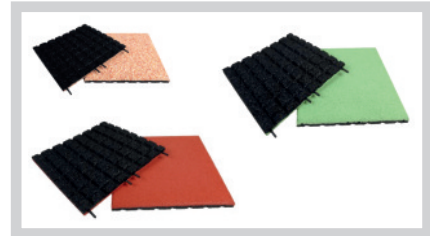

34/ Sheet with grass



35/ Sheet with parquet pattern



36 and 37/ Drilling, pins and connecting elements

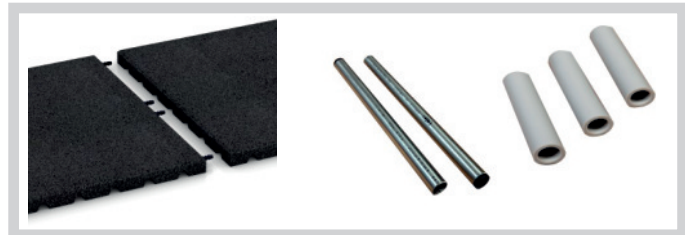

FLOOR SHEETS



The floor sheets serve as insulating, safety and protective coverings. The type of material used can be arbitrarily chosen according to the use in exterior or interior, as well as according to the degree of flammability, required resistance to chemicals, oils, petrol and many other substances.

...Immediate sealing effect



FLOOR RUBBER SHEETS

Default size in stock is 1200x10000mm and width 1400/1500/1800 / 2000mm, prices and availability on request.

Floor rubber sheets		Price		
no.	name	 thickness	1 - 11,99m ²	12 - 119,99m ²
1	Grooved design - small	3mm	288,70	165,00
		4mm	385,30	220,20
		5mm	593,40	339,10
2	Grooved design - large	3mm	340,10	222,20
		4mm	455,10	297,20
3	Grooved design - special	3mm	352,00	201,10
		4mm	474,40	271,10
4	Grooved design - mixed	3mm	352,20	228,10
		4mm	477,90	309,40
		5mm	603,60	390,90
		6mm	729,20	472,30
5	Coin design	3mm	352,00	201,10
		4mm	474,60	271,20
		5mm	784,20	448,10
		6mm	945,10	541,80
		7mm	1.274,80	728,50
6	Checker design	3mm	352,00	201,10
		4mm	474,40	271,10
		5mm	593,00	338,90
7	Hammer design	3mm	352,20	228,10
		4mm	477,90	309,40
		5mm	603,60	390,90
		6mm	729,20	472,30
8	Hammer design - special	8mm	1023,80	663,00
		10mm	1279,00	828,40
		12mm	1535,30	994,20
		15mm	1919,20	1.242,90
9	Pebble design	3mm	363,60	235,50
		4mm	484,60	313,80
		6mm	727,40	471,10
		8mm	969,20	627,70
10	Pebble design - special	12mm	2.101,50	1.360,90
		17mm	2.573,50	1.666,70
11	Cube design	8mm	1.049,80	599,80
12	Caro deska / Caro deska speciál	12mm	2.248,20	1.352,30

no.	name	 thickness	0,01 - 11,99m ²	od 12m ²
13	Coin colorful pvc - colorful	3mm	389,70	231,30

1/ Grooved design - small

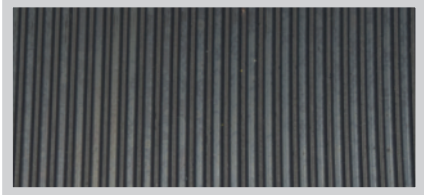

2/ Grooved design - large



3/ Grooved design - special



4/ Grooved design - mixed



5/ Coin design



6/ Checker design

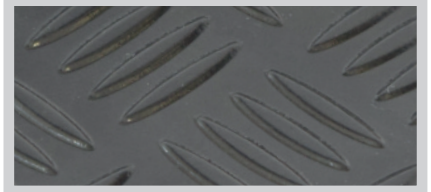

7/ Hammer design



8/ Hammer design - special

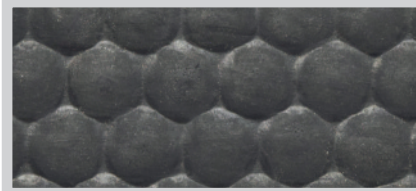

9/ Pebble design

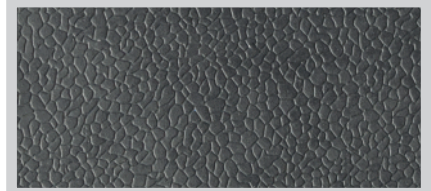

10/ Pebble design - special

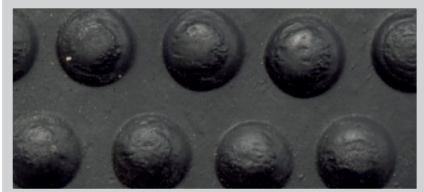

11/ Cube design



12/ Caro design (first page)



12/ Caro design - special (second page)

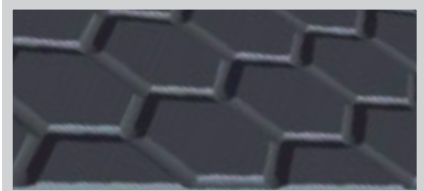

13/ Coin design - colorful

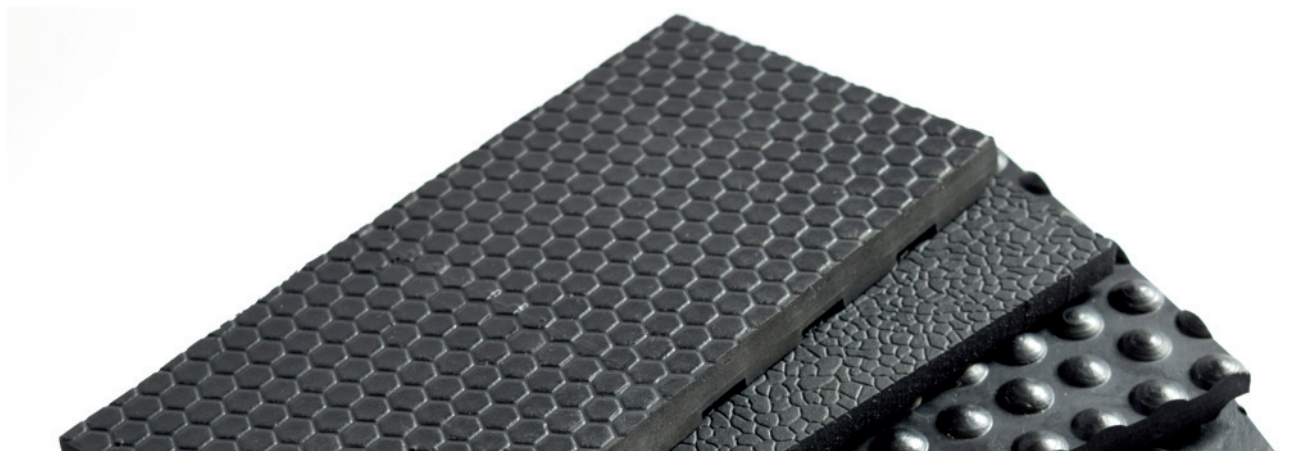
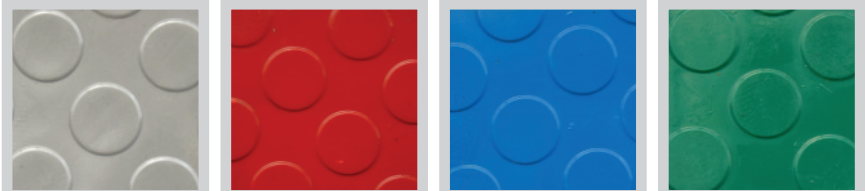

FLOOR SHEETS - PVC

Floor SHEETS- PVC			Price	
no.	name	 thickness	0,01 - 11,99m ²	od 12m ²
1	Grooved design - small	2,2mm	261,00	169,00
2	Coin design	2,2mm	261,00	169,00
3	Hammer design Grid design	2,2mm	261,00	169,00
4	Grid design	2,2mm	261,00	169,00
5	Pyramid design	2,2mm	261,00	169,00
6	Pyramid design - special	3,6mm	270,60	175,30
		4mm	333,90	216,20
7	Lens design	2,2mm	261,00	169,00
8	Coin design - colorful	2,2mm	261,00	169,00

1/ Grooved design - small



2/ Coin design



3/ Hammer design



4/ Grid design

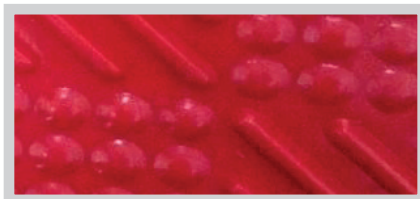

5/ Pyramid design

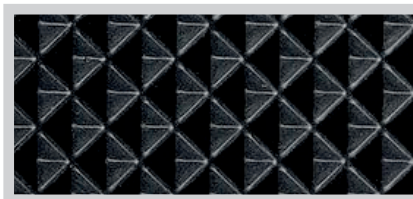

6/ Pyramid design - special

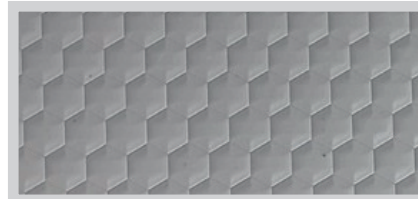

7/ Lens design

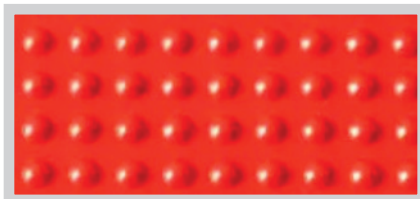

8/ Coin design - colorful

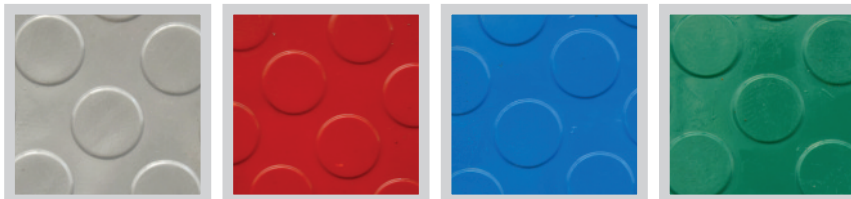

FLOOR RUBBER SHEETS

Floor rubber sheets							Price			
no.	ADITEG code	name	size 	kg/pcs	ks/pal		1 - 9 pcs	10 - 24 pcs	25 - 49 pcs	od 50 pcs
1	ADI-1019-32	Pontoon terrain portable roadway + connecting locks	4000x2000x32	330	5		38.021,40	35.486,70	33.268,80	31.311,80
2	ADI-1019A-32	Pontoon terrain portable roadway + connecting locks	3000x2000x32	264	5		31.220,00	29.138,70	27.317,50	25.710,60
3	ADI-1019-32	Pontoon terrain portable roadway + connecting locks	4000x1000x32	165	10		21.532,90	20.097,30	18.841,30	17.732,90
4	ADI-1019A-33	Pontoon terrain portable roadway + connecting locks	3000x1000x32	120	10		18.475,70	17.244,00	16.166,30	15.215,30
5	ADI-1019-43	Loading	1200x800x43	32	30		719,10	671,20	629,20	592,20
6	ADI-1029A-43	Loading - teardrop sheet	1200x800x43	34	30		761,60	710,80	666,40	627,20
7	ADI-1039-43	Loading- small	800x600x43	18	60		361,40	337,30	316,20	297,60
8	ADI-1039R-43	Loading grid	800x600x43	11	60		284,90	265,90	249,30	234,60
9	ADI-1069-43	Universal interior board	1200x800x43	28,5	30		670,50	625,80	586,70	552,20
10	ADI-1079-22	Small pebble plate	800x600x22	11,5	100		275,40	257,00	240,90	226,80
11	ADI-1099Z-22	Interior board small reinforced solid	80x600x22	12,5	100		275,40	257,00	240,90	226,80
12	ADI-1119-22	Stable mat small	800x600x22	10,2	100		255,90	238,90	223,90	210,80
13	ADI-1139-43	Paddock	1200x800x43	28	30		719,10	671,20	629,20	592,20
14	ADI-1139A-43	Paddock perforated (O25mm, 6x20mm)	1200x800x43	27	30		767,70	716,50	671,70	632,20
15	ADI-1159-22	Interior board	1200x800x22	2020	50		508,20	474,30	444,70	418,50
16	ADI-1159S-22	Interior board - teardrop	1200x800x22	19	50		508,20	474,30	444,70	418,50
17	ADI-1159A-22	Interior perforated plate (O25mm, 6x20mm)	1200x800x22	16,5	50		556,80	519,70	487,20	458,50
18	ADI-1179-12	Interior board smooth	1200x800x22	13,5	60		424,50	396,20	371,50	349,60
19	ADI-1179A-12	Interior smooth perforated board (O25mm, 6x20mm)	1200x800x22	16,5	60		470,70	439,30	411,80	387,60
20	ADI-1189-12	Stable mat smooth	1200x800x22	24	60		424,50	396,20	371,50	349,60
21	ADI-1209-22	Double-sided interior board	1200x800x22	16,5	50		573,80	439,30	502,10	472,50
22	ADI-1219-12	Smooth ball plate	1200x800x22	13,5	60		424,50	396,20	371,50	349,60
23	ADI-1219A-12	Smooth perforated ball (O25mm, 6x20mm)	1200x800x22	13,5	60		470,70	57,00	411,50	387,60
24	ADI-1219P-12	Ball plate smooth - puzzle	1158x780x12	11,5	60		561,70	524,30	491,50	462,60
25	ADI-1239-22	Interior - small ball plate - injected	800x600x22	20	100		275,40	257,00	240,90	226,80
26	ADI-1249-22	Interior - ball plate	1200x800x22	124	50		508,20	474,30	444,70	418,50
27	ADI-2505-43	High Ramp "under"	400x100x43	1,2			76,40	71,30	66,90	62,90
28	ADI-2515-22	Low Ramp "under"	400x100x22	0,6			60,60	56,60	53,10	49,90
29	ADI-2615-22	Low Ramp "over"	400x100x22	0,6			60,60	56,60	53,10	49,90
30	ADI-2625-43	High ramp "over" used for 102	400x100x43	1,2			76,40	71,30	66,90	62,90
31	ADI-2635-43	High ramp "over" 104, 105, 106, 113	400x100x43	1,2			76,40	71,30	66,90	62,90
32	ADI-2745-43	Connecting piece high	400x100x43	2			140,80	131,40	123,20	115,90
33	ADI-2795-22	Connecting piece low	400x100x22	1,2			114,10	106,50	99,80	93,90



1-4/ Ponton off-road plate + coupling locks 5/ Load plate

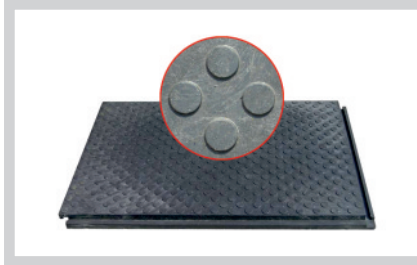
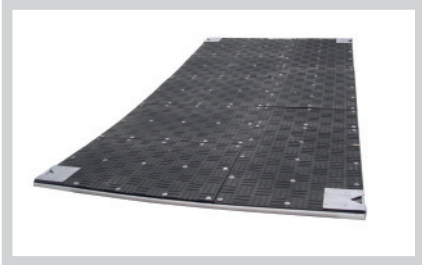

6/ Load plate - teardrop

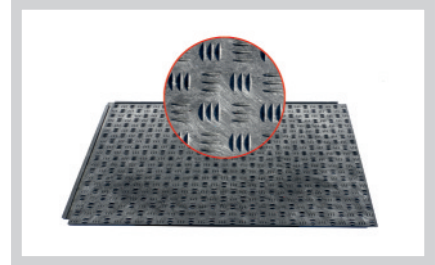

7/ Load plate - small

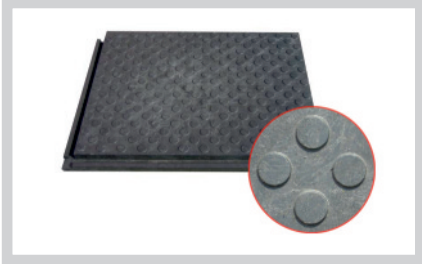

8/ Load grate

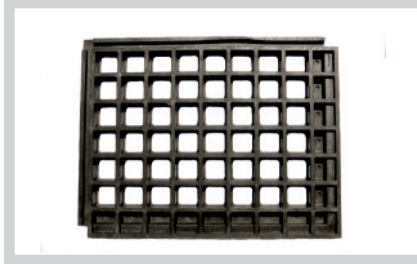

9/ Interior board - universal

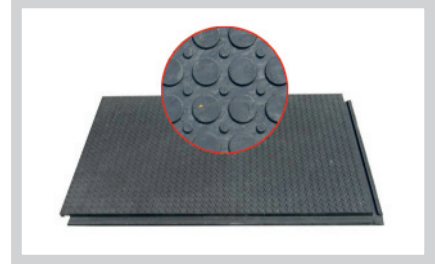

10/ Pebble plate - small

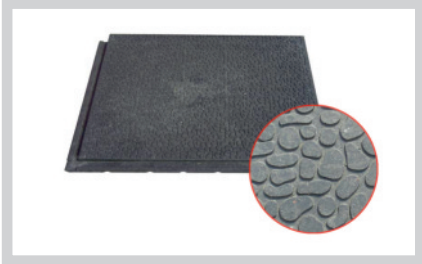

11/ Interior board - small, reinforced

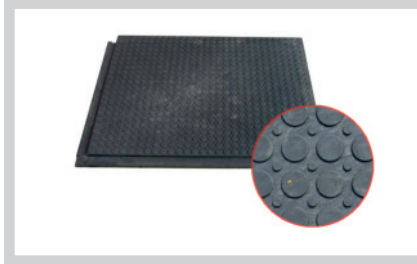

12/ Stable mat - small



13/ Paddock

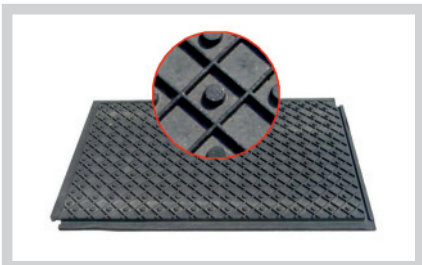

14/ Paddock - perforated

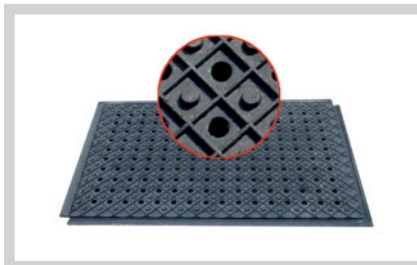

15/ Interior board

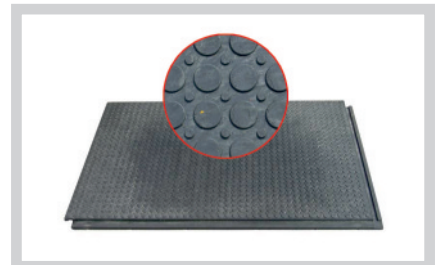

16/ Interior board - teardrop

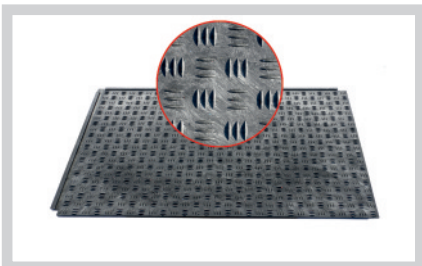

17/ Interior board - perforated

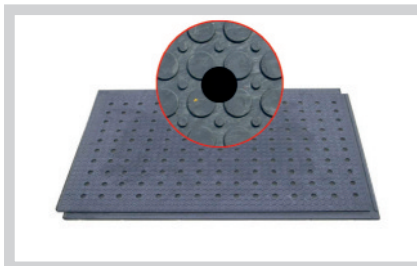

18/ Interior board - smooth

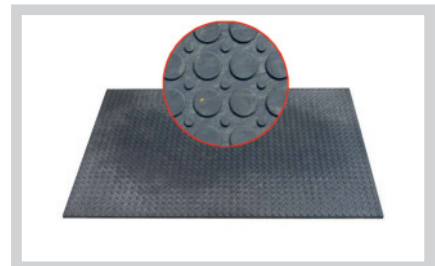

19/ Interior board - smooth, perforated

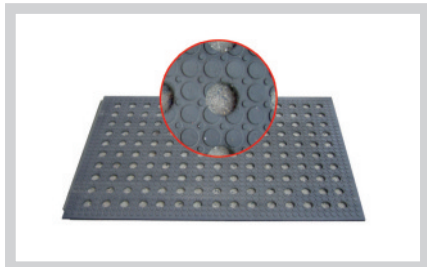

20/ Stable mat - smooth



21/ Interior board - double-sided

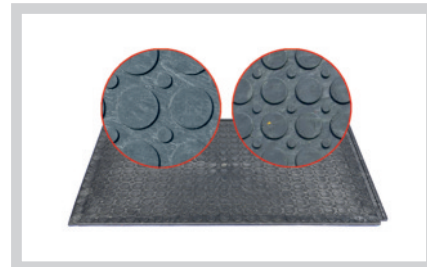

22/ Ball plate - smooth

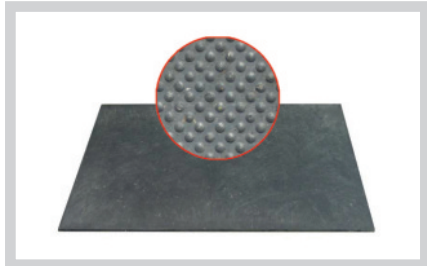

23/ Ball plate - smooth, perforated

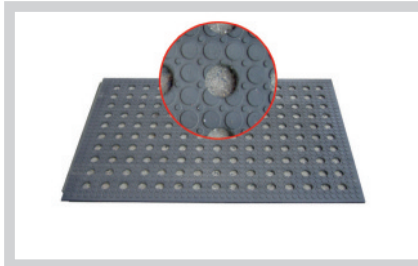

24/ PUZZLE ball plate - smooth

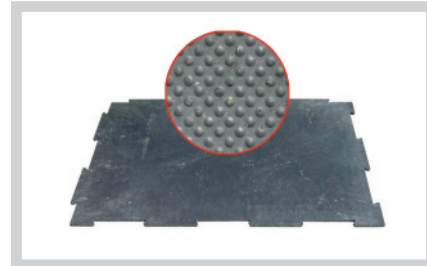

25/ Interior ball plate - small

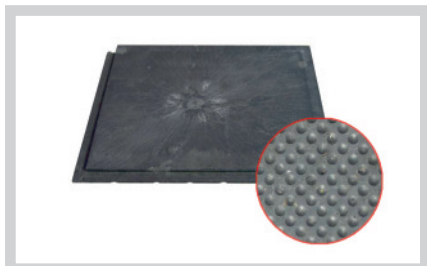

26/ Interior plate - ball

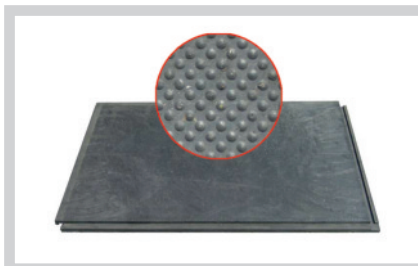

27/ Ride high „POD”



28/ Ramp under "POD"



29/ Raid low „OVER”



30/ Ride high „OVER” only for 102



31/ High Overrun 104, 105, 106, 113



32/ Connecting piece high



33/ Connecting piece low



RUBBER MATS

You can find NEW quality rubber mats in the product range of ADITEG s.r.o., which can be delivered in sizes according to the measurements below. Rubber mats are suitable not only for indoors but also for outdoors. In addition to the cleaning function, the entrance gets a representative look, which is important for the first impression of the visitor. Entrance rubber mats are ideal not only for the entrance area, but also for the front of staircases, workrooms, working compartments where water leaks through and they are suitable for travel of pallet trucks with lower loads or car parks. These mats increase productivity, remove coarse dirt or snow, reduce noise and act as insulation. The mat is a comprehensive program for safety, cleanliness and comfort. It is ideal for wet, muddy and snowy areas. We offer rubber mats of various sizes and colors at bargain prices.

Advantages and interesting facts: Easy maintenance in general. They are shaped so that people do not stumble over them. The edge of the mat is often formed by a leading edge, which limits the possibility of stumbling over or falling and it allows the car to pass through it easily

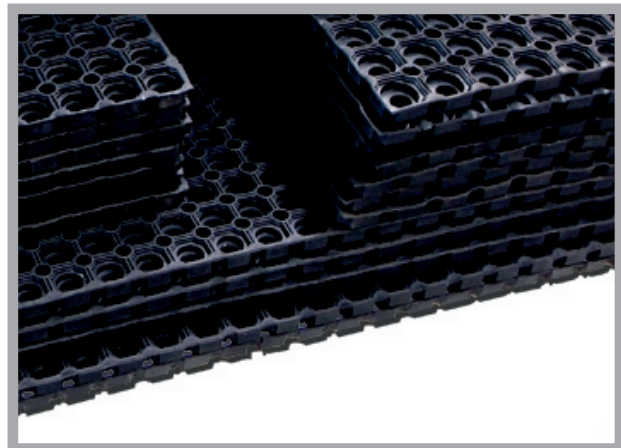
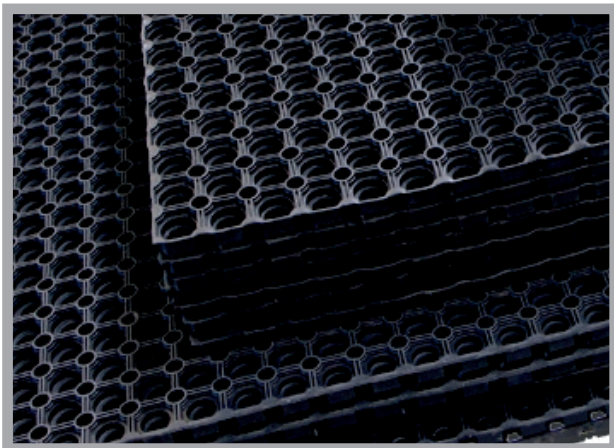
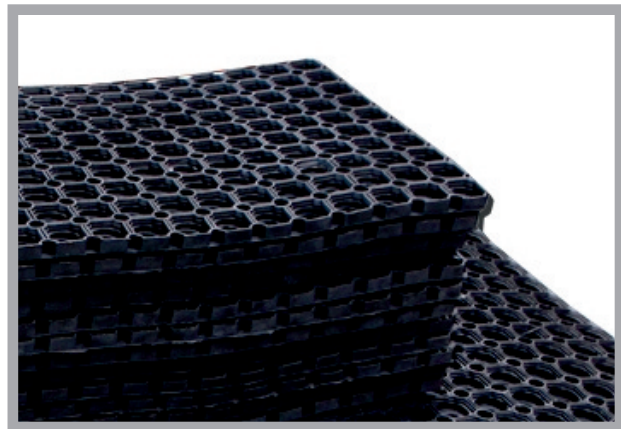
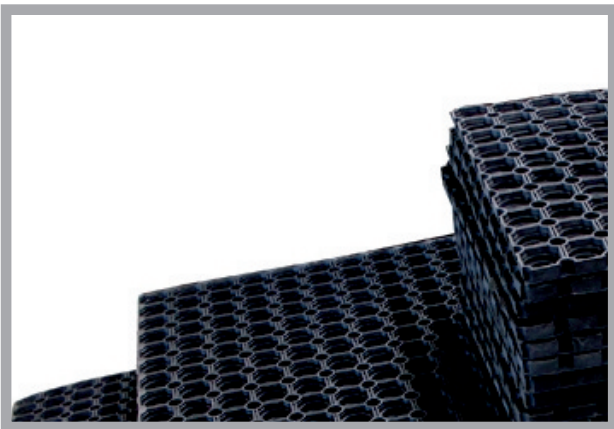

RUBBER MATS

MATS IN FRONT OF THE ENTRANCE DOOR



RUBBER MATS

Rubber mats - mats in front of the entrance doors					Price		
no.	ADITEG code	size 	1 - 4 pcs	5 - 9 pcs	10 - 49 pcs	50 - 99 pcs	od 100 pcs
1	101-ADI-welcome	450x750mm	94,80	75,90	63,20	54,20	50,60
2	102-ADI-holes	400x600mm	67,30	53,80	44,90	38,50	35,90
		400x700mm	72,60	58,10	48,40	41,50	38,70
		450x750mm	127,70	102,20	85,10	73,00	68,10
3	103-ADI-track	400x600mm	56,60	45,30	37,70	32,30	30,20
		450x750mm	94,80	75,90	63,20	54,20	50,60
4	104-ADI-leaf	400x600mm	56,60	45,30	37,70	32,30	30,20
		450x750mm	94,80	75,90	63,20	54,20	50,60
5	105-ADI-cube	400x600mm	56,60	45,30	37,70	32,30	30,20
		450x750mm	94,80	75,90	63,20	54,20	50,60
6	106-ADI-cat	400x600mm	56,60	45,60	37,70	32,30	30,20
		450x750mm	94,80	75,90	63,20	54,20	50,60
7	107-ADI-leaves	400x600mm	56,60	45,30	37,70	32,30	30,20
8	108-ADI-leaf / welcome	400x600mm	56,60	45,30	37,70	32,30	30,20
		450x750mm	71,10	56,90	47,40	40,60	37,90
9	109-ADI-holes	400x600mm	87,20	49,70	58,10	49,80	46,50
		450x750mm	162,90	130,30	108,60	93,10	86,90
10	110-ADI-dog	400x600mm	61,20	48,90	40,80	35,00	32,60
		450x750mm	99,40	79,50	66,30	56,80	53,00
11	111-ADI belt	450x750mm	196,50	157,20	131,00	112,30	104,80
12	112-ADI track / lavor	400x800mm	129,20	103,40	86,20	73,80	68,90
13	113-ADI-maze	400x700mm	71,10	56,90	47,40	40,60	37,90
14	114-ADI belt / lavor	400x800mm	129,20	103,40	86,20	73,80	68,90
		400x900mm	147,60	118,10	98,40	84,30	78,70
15	115-ADI-caro	400x600mm	87,20	69,70	58,10	49,80	46,50
16	116-ADI-semicircle	450x750x16mm	119,30	95,40	49,50	68,20	63,60
		450x750x22mm	168,20	134,60	112,20	96,10	89,70
17	117-ADI-welcome / oval	400x700mm	71,10	56,90	47,40	40,60	37,90
18	118-ADI-cube	400x700mm	71,10	56,90	47,40	40,60	37,90
19	119-ADI-Rectangle	400x700mm	94,80	75,90	63,20	54,20	50,60
20	120-ADI-maze / welcome	400x700mm	71,10	56,90	47,40	40,60	37,90

1/ WELCOME



2/ HOLES

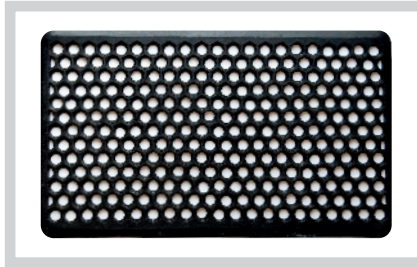

3/ TRACK



4/ LEAF

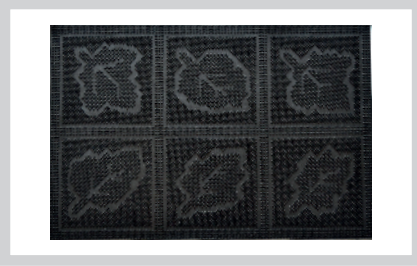

5/ CUBE



6/ CAT

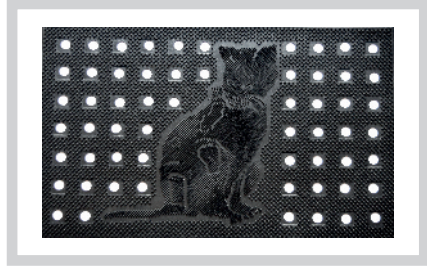

7/ LEAVES



8/ LEAVES - WELCOME



9/ HOLES

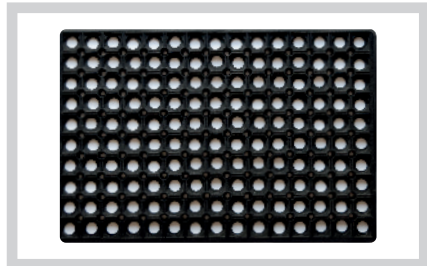

10/ DOG

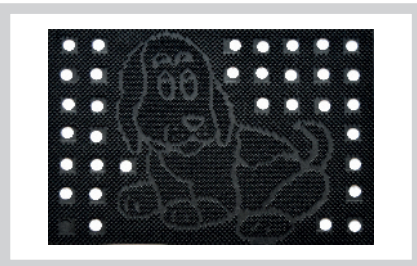

11/ BELT

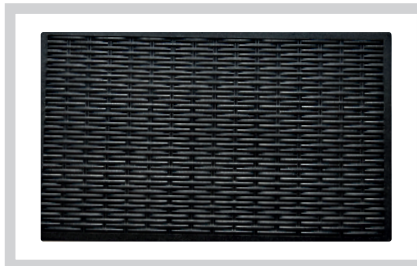

12/ TRACK - LAVOR



13/ MAZE



14/BELT - LAVOR



15/ CARO

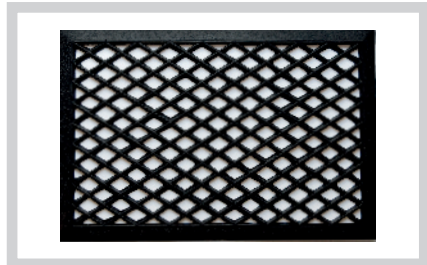

16/ SEMICIRCLE

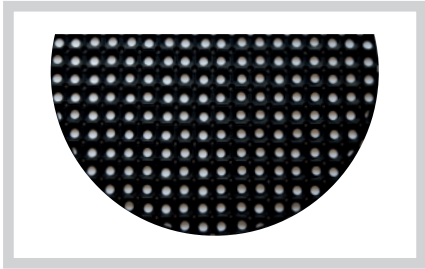

17/ WELCOME - OVAL



18/ CUBE



19/ RECTANGLE



20/ MAZE - WELCOME



Rubber mats				Price				
no.	ADITEG code	size 	color	1 - 4 pcs	5 - 9 pcs	10 - 49 pcs	50 - 99 pcs	od 100 pcs
1	ADITEG-402	1524x914x12mm	● black	640,80	587,30	542,10	503,50	469,80
		1524x914x12mm	● red	855,70	784,40	721,00	672,40	627,50
2	ADITEG-404	1000x1000x13mm	● black	559,80	513,00	473,60	439,80	410,40
3	ADITEG-404-C	1800x1000x22mm	● black	676,40	619,90	572,30	531,40	496,00
		1200x800x22mm	● black	468,40	429,40	396,30	368,00	343,40
		1000x500x22mm	● black	180,90	165,90	153,00	142,10	132,70
		800x500x22mm	● black	158,00	144,70	133,60	124,10	115,90
		600x400x22mm	● black	81,30	74,50	68,80	63,90	59,70
		1800x1000x16mm	● black	595,60	546,00	504,00	468,10	436,90
		1200x800x16mm	● black	368,20	337,60	311,60	289,30	270,0
		1000x500x16mm	● black	157,40	144,30	133,20	123,70	115,30
4	ADITEG-406	800x500x16mm	● black	155,50	142,60	131,70	122,30	114,00
		600x400x16mm	● black	65,70	60,30	55,50	51,60	48,10
		1500x900x12mm	● black	533,80	489,20	451,70	419,50	391,50
		1524x914x12mm	● red	902,10	827,00	763,30	708,80	661,60
5	ADITEG-407	910x910x12mm	● black	265,10	243,00	224,30	208,30	194,40
		910x910x14mm	● black	330,50	303,00	279,60	259,70	242,50
		915x915x12mm	● red	637,00	584,00	538,90	500,60	467,20
6	ADITEG-408	1500x900x22mm	● black	915,40	845,00	784,60	732,20	686,60
		1500x900x22mm	● red	1.252,20	1.155,90	1.073,30	1.001,80	939,20
7	ADITEG-409	1200x800x20mm	● black	984,40	908,60	843,80	787,50	738,30
8	ADITEG-410	1200x800x20mm	● black	984,40	908,60	843,80	787,50	738,30
9	ADITEG-411	500x500x8mm	● black	180,00	166,10	154,30	144,00	135,00
10	ADITEG-412	390x390x25mm	● black	253,20	230,40	217,00	205,00	189,90
11	ADITEG-413	1500x1000x23mm	● black	830,50	808,90	787,30	746,60	699,80
12	ADITEG-414	1000x1000x17mm	● black	949,50	876,50	815,90	759,60	712,10
13	ADITEG-415	910x910x14mm	● black	379,70	350,50	325,40	303,80	284,80
14	ADITEG-416	1500x900x10,5mm	● black	548,40	506,30	470,10	438,80	411,30
15	ADITEG-417	910x910x16mm	● black	432,60	399,30	370,80	346,10	324,40
16	ADITEG-418	900x600x15mm	● black	195,20	180,20	167,30	156,20	146,40
		1200x900x15mm	● black	395,40	365,00	338,90	316,40	296,60
17	ADITEG-419	1800x900x8mm	● black	738,60	681,80	633,10	590,90	553,90
		1500x900x8mm	● black	685,70	632,90	587,70	548,60	514,30
		1000x600x8mm	● black	200,30	184,80	171,60	160,20	150,20
		750x450x8mm	● black	92,80	85,70	79,60	74,30	69,60
		600x400x8mm	● black	48,40	44,70	41,50	38,70	36,30

1/ ADITEG-402

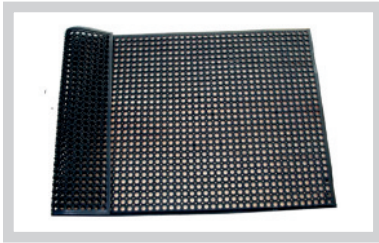

2/ ADITEG-404

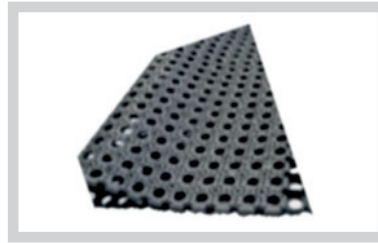

3/ ADITEG-404-C

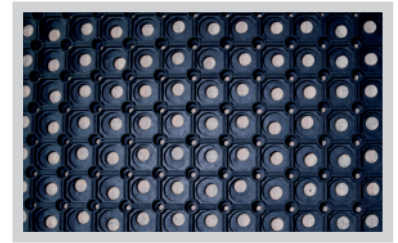

4/ ADITEG-406

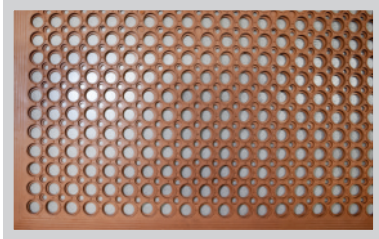

5/ ADITEG-407

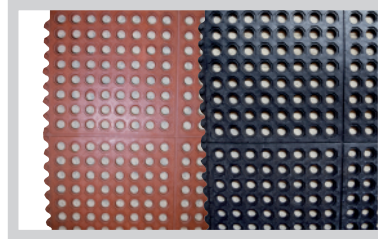

6/ ADITEG-408

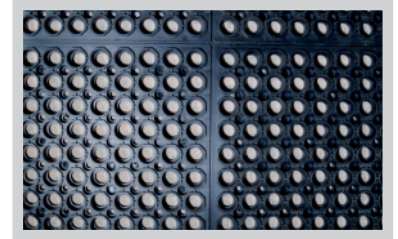

7/ ADITEG-409

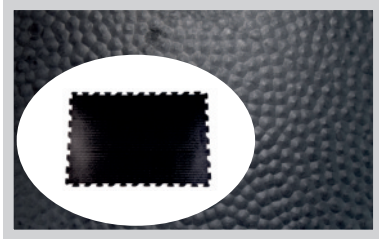

8/ ADITEG-410

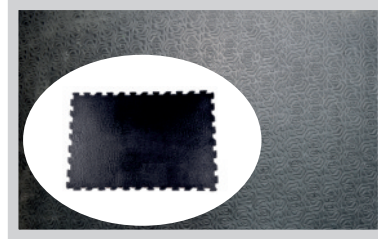

9/ ADITEG-411

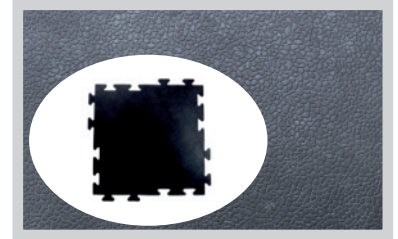

10/ ADITEG-412

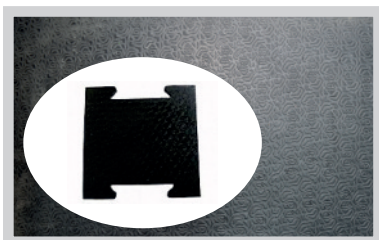

11/ ADITEG-413

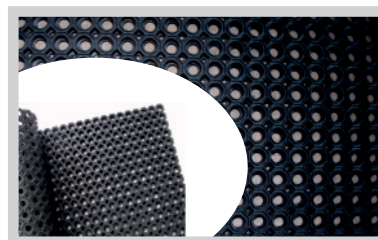

12/ ADITEG-114

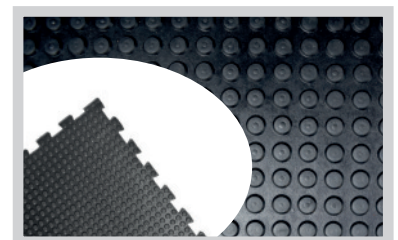

13/ ADITEG-415

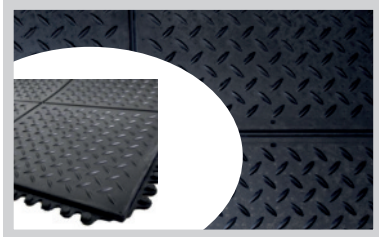

14/ ADITEG-416



15/ ADITEG-417

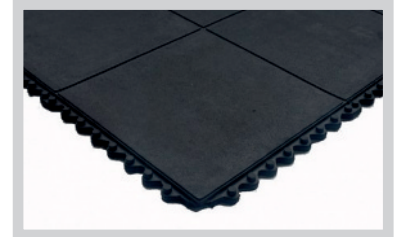

16/ ADITEG-418

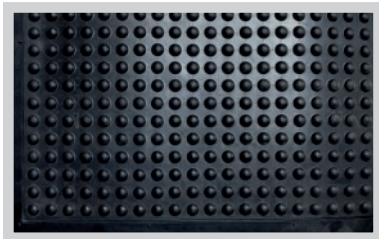

17/ ADITEG-419

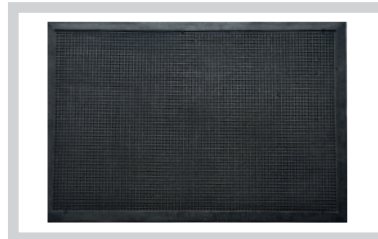

Plastic mat with so-called spaghetti (noodle) effect, which creates a strong and durable base with tangled lines that catch dirt, impurities and excess moisture. The surface of the mat is very soft and pleasant, so it can also be walked on bare feet and it can be used as a pool or a shower mat.

The bottom of the mat is not closed, therefore the accumulated water flows out from below the mat surface.

- Significant anti-slip effect
- Mats absorb and relieve spinal vertebrae.
- Non-flammable and oil resistant
- Can be used as interior and exterior mats
- Easy maintenance by tapping, suction, washing with water and common detergents

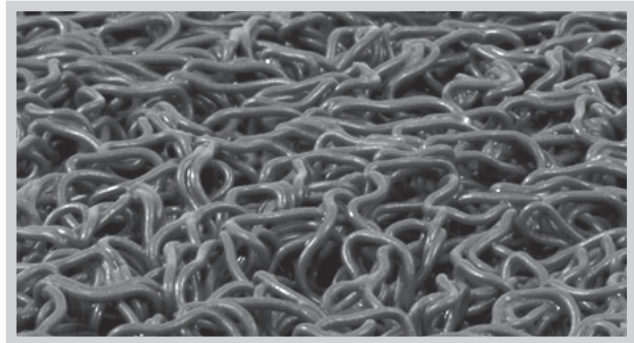

Anti-slip mats - material PVC		Price	
 thickness	0,01 - 17,99m ²	18 - 179,99m ²	
12mm	754,20	488,50	
15mm	919,30	595,30	

RUBBER MATS

BATHROOM ANTI - SLIP



PVC anti-slip bathroom mats			Price				
no.	name	size 	1 - 5 pcs	6 - 24 pcs	25 - 99 pcs	100 - 199 pcs	od 200 pcs
1	Flower	595x595mm	123,10	114,90	107,80	101,40	95,80
2	Oval	700x395mm	104,40	97,50	91,40	86,00	81,20
3	Rectangle	595x350mm	84,00	78,40	73,50	69,20	65,30
4	Ring	Ø 540mm	123,00	114,80	107,70	101,30	95,70
5	Cat	565x500mm	96,90	90,40	84,80	79,80	75,30
6	Semicircle	595x400mm	89,00	83,10	77,90	73,30	69,20
7	Toilet rug	595x595mm	130,60	121,90	114,30	107,50	101,60
8	Dolphin	595x200mm	117,70	109,80	103,00	96,90	91,50
9	Shells	555x485mm	114,40	106,80	100,10	94,20	89,00

1/ FLOWER

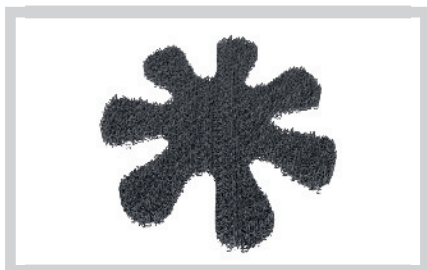

2/ OVAL

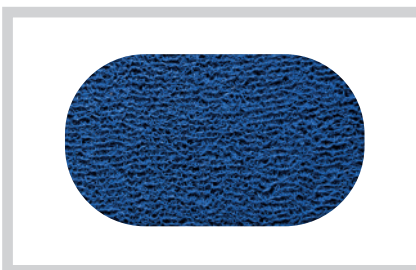

3/ RECTANGLE

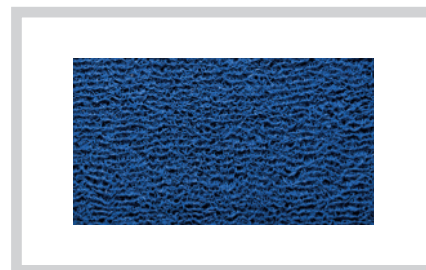

4/ RING

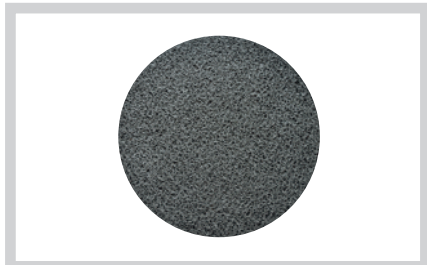

5/ CAT

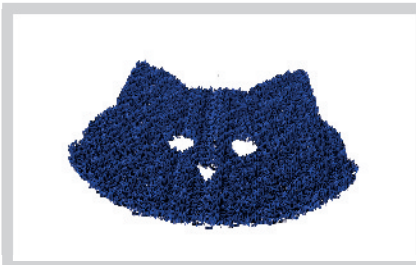

6/ SEMICIRCLE

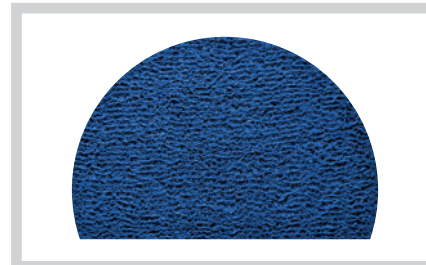

7/ TOILET RUG



8/ DOLPHIN

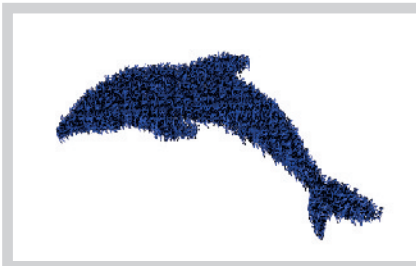

9/ SHELLS







RUBBER MATS FOR HORSE STABLES

ADITEG, G like rubber, this is the comfort for your horses

Equip cattle, horses stables and dog pens with high quality insulated sheets (so-called stable rubber). Our stable floor rubber mats and animal pens floor sheets are made of SBR 65 +/- 5 Sha.

- increase the comfort of horses in stables
- anti-slip, flexible, soft
- keep warmth
- reduce noise, dampen impacts, prevent injury to animals
- less bedding consumption, lower financial costs
- only rinsing with water is sufficient for maintenance

Rubber mats for horse stables				Price				
no.	ADITEG	size 	color	1 - 4 pcs	5 - 9 pcs	10 - 49 pcs	50 - 99 pcs	od 100 pcs
1	ADITEG-411	500x500x8mm	● black	180,00	166,10	154,30	144,00	135,00
2	ADITEG-412	390x390x25mm	● black	253,20	230,40	217,00	205,00	189,90
3	ADITEG-415	910x910x14mm	● black	379,70	350,50	325,40	303,80	284,80
4	ADITEG-417	910x910x16mm	● black	432,60	399,30	370,80	346,10	324,40
5	ADITEG-414	1000x1000x17mm	● black	949,50	876,50	815,90	759,60	712,10
6	ADITEG-423	1000x1000x18mm	● black	1.149,30	1.021,60	919,40	835,80	766,20
7	ADITEG-410	1200x800x20mm	● black	984,40	908,60	843,80	787,50	738,30
8	ADITEG-409	1200x800x20mm	● black	984,40	908,60	843,80	787,50	738,30
no.	ADITEG	size 	color	0,01 - 11,99 m ²		12 - 99,99 m ²		od 100 m ²
9	Regranulát	1250x10000x8mm	● black	200,40		167,00		154,20
		1250x6000x10mm	● black	240,80		200,70		185,30
		1250x6000x12mm	● black	291,20		242,70		224,00
		1150x2300x15mm	● black	342,30		285,20		263,50
		1150x2300x20mm	● black	494,70		412,30		380,60
10	Deska ADITEG - kostková	1250x10000x8mm	● black	749,80		583,20		403,80
no.	ADITEG	size 	color	0,00 - 11,16 m ²		11,17 - 111,62 m ²		od 111,63 m ²
11	Deska ADITEG - kamínková speciál	1220x1830x12mm	● black	693,90		449,40		390,77
		1220x1830x17mm	● black	971,10		628,90		546,90
12	Deska ADITEG - Caro / Caro speciál	1220x1830x12mm	● black	1.405,20		1.124,20		864,80
no.	ADITEG	size 	color	0,01 - 9,99 m ²	10 - 29,99 m ²	30 - 49,99 m ²	50 - 99,99 m ²	od 100 m ²
13	ADITEG-422	1000x2000x10mm	● black	959,60	852,90	767,60	697,90	639,70
		1000x2000x15mm	● black	1.404,40	1.248,40	1.123,50	1.021,40	936,30
		1000x2000x20mm	● black	1.775,70	1.578,40	1.420,60	1.291,40	1.183,80

1/ ADITEG-411

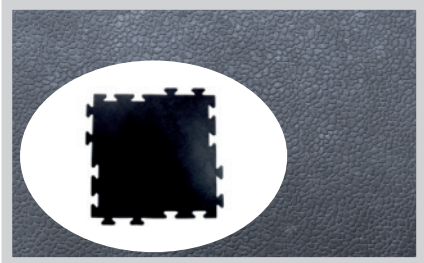

2/ ADITEG-412

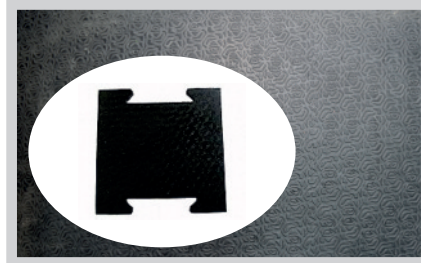

3/ ADITEG-415



4/ ADITEG-417

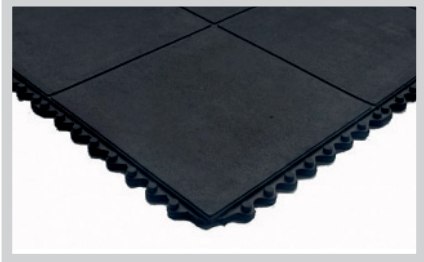

5/ ADITEG-414

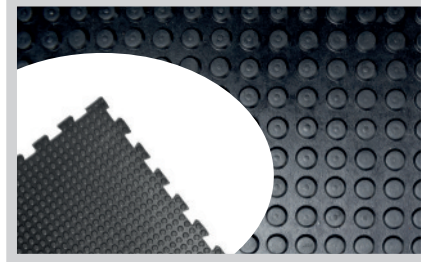

6/ ADITEG-423



7/ ADITEG-410

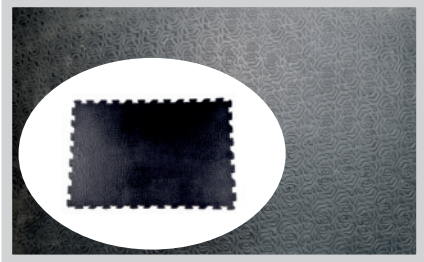

8/ ADITEG-409

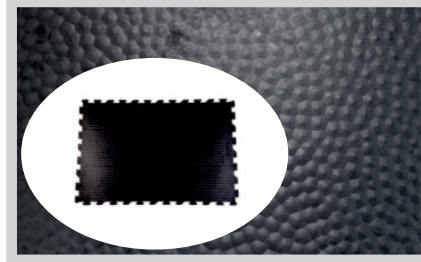

9/ REGRANULATE

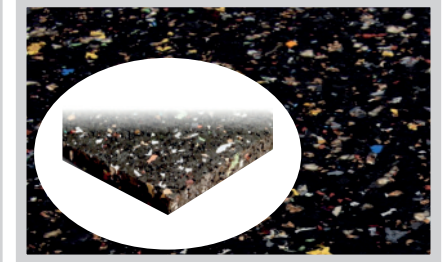

10/ ADITEG - cube



11/ ADITEG - pebble special

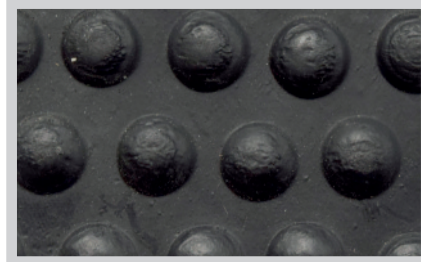

12/ ADITEG - Caro



12/ ADITEG - Caro special

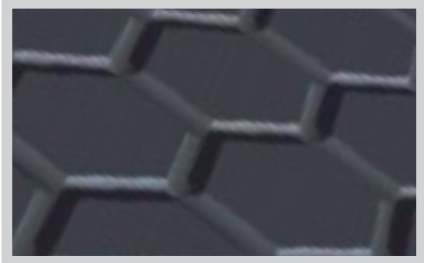

13/ ADITEG - 422

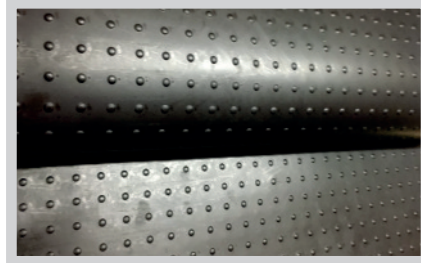

NON-ASBESTOS SHEETS ADISEAL

ADISEAL – Non-asbestos sealing sheets, fiber CSF sealing sheets

Non-asbestos sealing sheets are widely used in all industries, such as the automotive industry, engineering, etc.

Applications: water, gases, oils, alcohols, basic chemicals

Certification: Germanischer Lloyd, KTW

- raw weight DIN 28 090 - 2: 1.9 - 2.2g / cm²
- Color: red, yellow, blue
- Temperature resistance (permanent): + 140 ° C
- Temperature resistance (short term): + 210 ° C
- Steam resistance: + 120 ° C.
- Tensile strength DIN 52913:> 22 MPa
- compressibility ASTM F 36 - J 5: -15%
- ASTM F 36 - J recovery: min. 50%
- spec. Qty. leaks DIN 3535 - 6: 0.15 mg / (s.m)
- format of sheets: 1500x1500mm

Other materials according to specific demand.

Non-asbestos sheets		Price		
	thickness	0,01 - 2,24 m ²	2,25 - 11,24 m ²	OD 11,25 m ²
	0,5 mm	351,90	281,50	239,30
	1,0 mm	405,90	324,70	276,10
	1,6 mm	543,20	434,50	292,10
	2,0 mm	623,60	498,80	423,90
	3,0 mm	820,90	656,60	558,20
	4,0 mm	1.115,60	892,50	758,70
	5,0 mm	1.394,60	1.109,10	948,30

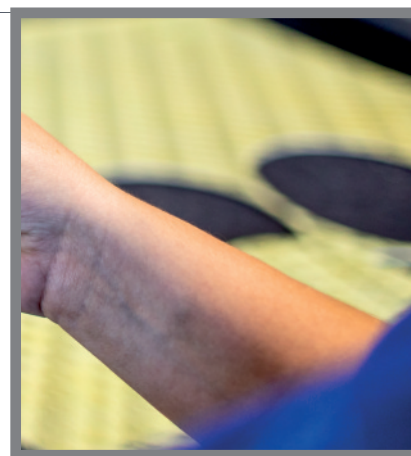

CONVEYOR BELTS

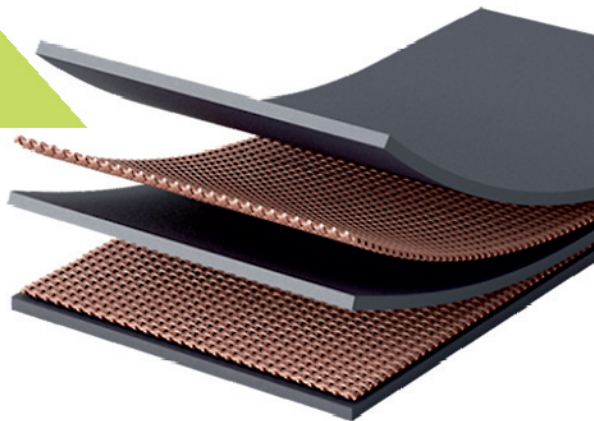

Conveyor belts				Price				
Type	inserts	thickness	width mm	0 - 9,99 bm	10 - 24,99 bm	25 - 49,99 bm	50 - 99,99 bm	od 100 bm
EP250/2Y	2	6,5 mm	400	277,30	256,00	237,70	211,80	208,00
			500	346,40	319,80	296,90	277,10	259,80
			650	450,40	415,70	386,00	360,30	337,80
			800	554,30	511,60	475,10	443,40	415,70
			1000	692,90	639,60	593,90	554,30	519,60
EP315/2AA	2	7 mm	400	307,90	284,20	263,90	246,30	230,90
			500	384,90	355,30	329,90	307,90	288,70
			650	500,30	461,90	428,90	400,30	375,30
			800	615,80	568,40	527,80	492,70	461,90
			1000	769,80	710,60	659,80	615,80	577,40
EP400/3Y	3	9 mm	400	388,00	358,10	332,60	310,40	291,00
			500	485,00	447,70	415,70	388,00	363,70
			650	630,40	581,90	540,40	504,40	472,80
			800	1.746,00	1.611,70	1.496,60	1.396,80	1.309,50
			1000	970,00	895,40	831,40	776,00	727,50
EP500/3AA	3	9 mm	400	404,90	313,70	347,00	323,90	303,60
			500	506,80	467,80	434,40	405,40	380,10
			650	657,90	607,30	563,90	526,30	493,40
			800	809,70	747,40	694,00	647,80	607,30
			1000	1.012,10	934,30	867,50	809,70	759,10
EP630/3AA	3	10 mm	400	486,20	448,80	416,80	389,00	364,70
			500	607,80	561,00	521,00	486,20	455,80
			650	790,10	729,30	677,20	632,10	592,60
			800	972,40	897,60	833,50	777,90	729,30
			1000	1.215,50	1.122,00	1.041,90	972,40	911,60
EP630/4A	4	12,2 mm	400	547,40	505,30	469,20	437,90	410,60
			500	684,30	631,70	586,50	547,40	513,20
			650	889,60	821,10	762,50	711,60	667,20
			800	1.094,80	1.010,60	938,40	875,80	821,10
			1000	1.368,50	1.263,30	1.173,00	1.094,80	1.026,40
			1200	1.642,20	1.515,90	1.407,60	1.313,80	1.231,70



CONVEYOR BELTS

PTFE - SHEETS / RODS



...Immediate sealing effect

PTFE sheets

PTFE sheet		Price	
thickness	size	0,01 - 7,19 m2	od 7,20 m2
0,3mm	1200x1200mm	441,96	331,47
0,5mm	1200x1200mm	563,73	422,79
0,7mm	1200x1200mm	789,22	591,91
1mm	1200x1200mm	1.127,45	845,59
1,5mm	1200x1200mm	1.691,18	1.268,38
2mm	1200x1200mm	2.254,90	1.691,18
2,5mm	1200x1200mm	2.818,63	2.113,97
3mm	1200x1200mm	3.382,35	2.536,76
4mm	1200x1200mm	4.509,80	3.382,35
5mm	1200x1200mm	5.637,25	4.227,94
6mm	1200x1200mm	6.764,71	5.073,53
8mm	1200x1200mm	7.816,99	5.862,75
9mm	1200x1200mm	8.794,12	6.595,59
10mm	1200x1200mm	9.771,24	7.328,43



PTFE rods

PTFE rod	Price	
diameter	0,01 - 9,99 m	od 10,00 m
10mm	88,80	64,60
20mm	355,47	258,52
30mm	799,77	581,65
40mm	1.421,80	1.034,03
50mm	2.221,64	1.615,74
60mm	3.199,06	2.326,59
70mm	4.354,38	3.166,82
80mm	5.687,34	4.136,25
90mm	7.197,97	5.234,89
100mm	8.886,41	6.462,84
110mm	10.752,73	7.820,17
120mm	12.796,09	9.306,25
130mm	15.017,97	10.922,16
140mm	17.417,00	12.667,05
150mm	19.994,53	14.541,48



PTFE - TAPES

PTFE tapes

Features: Made of 100% pure, expanded PTFE, single-sided self-adhesive tape for easy installation. High chemical resistance, anti-leaking, anti-aging, anti-weathering and UV stable. Effective sealing of uneven surfaces. Suitable for installation, high pressure, stable and has excellent adaptability.

Fast and easy installation

Universal use as static seals in almost all industries, but above all as seals for permanent flanges in similar applications. Physiologically safe, tasteless, odorless, cannot be attacked or decomposed by microorganisms. FDA 21CFR requirements 177,1550 and EU regulations 1935/2004 are met. DVGW, BAM and FDA certified.

Temperature resistance of material:

-240 degrees Celsius, +270 degrees Celsius, +315 degrees Celsius short term

PTFE tapes		price		
size	0,01 - 99,99 bm	100 - 199,99 bm	od 200 bm	
3 x 1,5mm	22,60	21,10	19,80	
5 x 2mm	28,20	26,30	24,70	
6 x 4mm	43,70	40,70	38,20	
7 x 2,5mm	31,60	29,50	27,70	
10 x 3mm	49,70	46,40	43,50	
12 x 4mm	66,20	61,80	57,90	
14 x 5mm	96,30	89,90	84,30	
20 x 5mm	136,90	127,80	119,80	
17 x 6mm	143,90	133,40	124,90	
20 x 7mm	159,40	148,80	139,50	



SILENTBLOCKS



Rubber-metal anti-vibration elements (silent blocks) are components designed for flexible mounting, shock absorption, active passive isolation of both vertical and transverse vibrations, noise insulation, transmission of forces, protective mounting, etc. They are fitted with a screw, i.e. an external or an internal thread, or a combination of individual dimensions for mounting.

For easy differentiation we divide silentblocks into five basic types according to the mounting method:

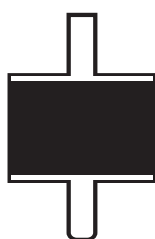

Typ A
double-sided
outdoor thread

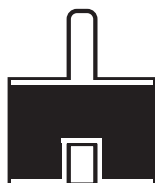

Typ B
double-sided
outdoor / indoor thread



Typ C
double-sided
indoor thread



Typ D
single-sided
outdoor thread



Typ E
single-sided
indoor thread

Silentblocks are made of elastomer in a wide range of shapes, diameters and lengths. However, cylindrical silentblocks are most often used.



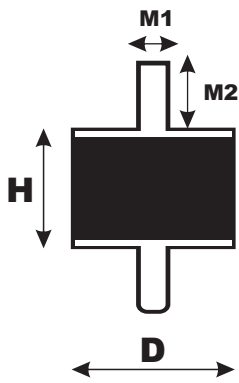

SILENTBLOCK - TYP A

DOUBLE -SIDED OUTDOOR THREAD

D	H	M1xM2	1 - 9 ks	10 - 24 ks	25 - 49 ks	50 - 99 ks	100 - 199 ks
15	8	M4x10	11,10	8,90	8,10	7,40	6,90
	10	M4x10	12,00	9,60	8,80	8,00	7,40
	15	M4x10	12,00	9,60	8,80	8,00	7,40
	20	M4x10	12,20	9,70	8,80	8,10	7,50
	30	M4x10	12,30	9,80	9,00	8,20	7,60
20	8	M6x18	15,30	12,30	11,20	10,20	9,40
	10	M6x18	15,70	12,50	11,40	10,50	9,70
	13,5	M6x18	15,90	12,70	11,60	10,60	9,80
	15	M6x18	16,30	13,00	11,80	10,80	10,00
	20	M6x18	17,20	13,70	12,50	11,40	10,60
	25	M6x18	17,70	14,20	12,90	11,80	10,90
	30	M6x18	18,30	14,60	13,30	12,20	11,30
25	10	M6x18	22,30	17,80	16,20	14,80	13,70
	15	M6x18	24,10	19,30	17,50	16,10	14,80
	20	M6x18	24,50	19,60	17,90	16,40	15,10
	25	M6x18	24,90	19,90	18,10	16,60	15,30
	30	M6x18	25,80	20,60	18,80	17,20	15,90
30	15	M6x18	26,40	23,10	20,90	19,40	18,20
	20	M6x18	33,20	26,50	24,10	22,10	20,40
	25	M6x18	34,70	27,70	25,20	23,10	21,30
	30	M6x18	36,10	28,90	26,30	24,10	22,20
40	40	M6x18	39,10	31,30	28,40	26,10	24,10
	20	M8x23	37,60	30,10	27,40	25,10	23,10
	30	M8x23	42,50	34,00	30,90	28,30	26,20
50	40	M8x23	50,50	40,40	36,70	33,60	31,00
	20	M10x28	61,30	49,00	44,50	40,80	37,70
	25	M10x28	64,10	51,30	46,60	42,70	39,40
	30	M10x28	68,50	54,80	49,80	45,70	42,20
	35	M10x28	72,00	57,60	52,40	48,00	44,30
	40	M10x28	75,80	60,60	55,10	50,50	46,60
60	45	M10x28	78,80	63,00	57,30	52,50	48,50
	50	M10x28	83,20	66,50	60,50	55,50	51,20
	30	M12x37	101,00	80,80	73,50	67,30	62,20
70	40	M12x37	103,40	82,70	75,20	68,90	63,60
	35	M12x32	123,20	98,50	89,60	82,10	75,80
75	45	M12x32	130,60	104,50	95,00	87,00	80,30
	25	M12x37	158,00	126,40	114,90	105,30	97,20
	40	M12x37	181,80	145,50	132,20	121,20	111,90
	50	M12x37	200,80	160,60	146,00	133,90	123,60
100	55	M12x37	214,80	171,80	156,20	143,20	132,20
	30	M16x42	326,60	261,30	237,50	217,70	201,00
	40	M16x42	337,00	269,60	245,10	224,70	207,40
	50	M16x42	369,20	295,40	268,50	246,10	227,20
	55	M16x42	380,90	304,70	277,00	253,90	234,40
	60	M16x42	395,50	316,40	287,60	263,60	243,40
150	75	M16x42	439,30	351,50	319,50	292,90	270,30
	45	M16x42	936,90	749,50	681,40	624,60	576,60
	50	M16x42	975,00	780,00	709,10	650,00	600,00
	55	M16x42	1004,20	803,40	730,30	669,50	618,00
	60	M16x42	1039,20	831,40	755,80	692,80	639,50
75	M16x42	1138,50	910,80	828,00	759,00	700,60	

SILENTBLOCK - TYP B

DOUBLE -SIDED OUTDOOR / INDOOR THREAD

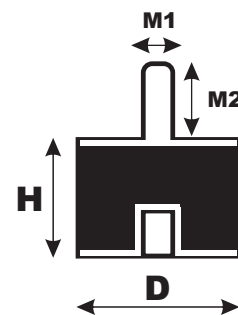

D	H	M1xM2	1 - 9 ks	10 - 24 ks	25 - 49 ks	50 - 99 ks	100 - 199 ks
15	8	M4x10	18,30	14,60	13,30	12,20	11,30
	10	M4x10	24,30	15,30	13,90	12,70	11,70
	15	M4x10	19,10	15,30	13,90	12,70	11,70
	20	M4x10	19,30	15,50	14,00	12,90	11,90
	30	M4x10	19,40	15,50	14,10	13,00	12,00
20	8	M6x18	25,10	20,10	18,30	16,70	15,50
	10	M6x18	25,50	20,40	18,50	17,00	15,70
	13,5	M6x18	25,70	20,50	18,70	17,10	15,80
	15	M6x18	26,00	20,80	18,90	17,30	16,00
	20	M6x18	26,90	21,50	19,60	18,00	16,60
	25	M6x18	27,50	22,00	20,00	18,30	16,90
	30	M6x18	28,10	22,50	20,40	18,70	17,30
25	10	M6x18	31,50	25,20	22,90	21,00	19,40
	15	M6x18	33,20	26,50	24,10	22,10	20,40
	20	M6x18	33,60	26,90	24,50	22,40	20,80
	25	M6x18	34,10	27,30	24,80	22,70	21,00
	30	M6x18	34,60	28,00	25,50	23,30	21,50
30	15	M6x18	37,10	31,50	29,50	25,50	22,50
	20	M6x18	40,50	32,40	29,40	27,00	24,90
	25	M6x18	41,80	33,50	30,40	27,90	25,70
	30	M6x18	43,30	34,60	31,50	28,90	26,60
	40	M6x18	46,30	37,00	33,60	30,80	28,50
40	20	M8x23	44,30	35,50	32,20	29,50	27,30
	30	M8x23	49,50	39,60	36,00	33,00	30,50
	40	M8x23	58,40	46,70	42,50	38,90	35,90
50	20	M10x28	68,30	54,60	49,70	45,50	42,00
	25	M10x28	71,30	57,00	51,80	47,50	43,80
	30	M10x28	75,60	60,50	55,00	50,40	46,50
	35	M10x28	79,10	63,30	57,50	52,70	48,70
	40	M10x28	83,00	66,40	60,30	55,30	51,00
	45	M10x28	85,80	68,60	62,40	57,20	52,80
	50	M10x28	90,20	72,20	65,60	60,20	55,50
60	30	M12x37	105,60	84,50	76,80	70,40	65,00
	40	M12x37	108,00	86,40	78,50	72,00	66,40
70	35	M12x32	127,80	102,30	93,00	85,20	78,70
	45	M12x32	135,10	108,10	98,30	90,10	83,10
75	25	M12x37	162,50	130,00	118,20	108,30	100,00
	40	M12x37	186,50	149,20	135,60	124,30	114,80
	50	M12x37	205,50	164,40	149,40	137,00	126,40
	55	M12x37	217,70	174,20	158,30	145,20	134,00
100	30	M16x42	328,80	263,00	239,10	219,20	202,30
	40	M16x42	339,20	271,40	246,70	226,10	208,70
	50	M16x42	371,30	297,00	270,00	247,50	228,50
	55	M16x42	383,00	306,40	278,50	255,30	235,70
	60	M16x42	397,60	318,10	289,20	265,10	244,70
	75	M16x42	441,40	353,10	321,00	294,20	271,60
150	45	M16x42	939,10	751,30	683,00	626,10	577,90
	50	M16x42	977,00	781,60	710,60	651,40	601,30
	55	M16x42	1006,30	805,00	731,80	670,80	619,20
	60	M16x42	1041,30	833,00	757,30	694,20	640,80
	75	M16x42	1140,60	912,50	829,50	760,40	701,90

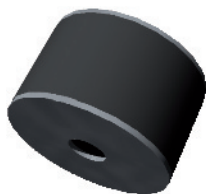
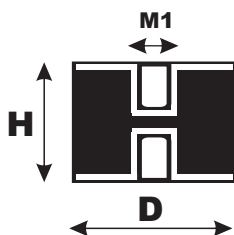

SILENTBLOCK - TYP C

DOUBLE-SIDED INDOOR THREAD

D	H	M1	1 - 9 ks	10 - 24 ks	25 - 49 ks	50 - 99 ks	100 - 199 ks
15	8	M4	25,30	20,30	18,40	16,90	15,60
	10	M4	26,30	21,00	19,10	17,50	16,20
	15	M4	26,30	21,00	19,10	17,50	16,20
	20	M4	26,40	21,10	19,20	17,60	16,20
	30	M4	26,50	21,20	19,30	17,70	16,30
20	8	M6	34,90	27,90	25,40	23,30	21,50
	10	M6	35,20	28,20	25,60	23,50	21,70
	13,5	M6	35,50	28,40	25,80	23,60	21,80
	15	M6	35,80	28,60	26,00	23,90	22,00
	20	M6	36,70	29,40	26,70	24,50	22,60
	25	M6	37,30	29,80	23,80	24,80	22,90
	30	M6	37,80	30,30	27,50	25,20	23,30
25	10	M6	40,70	32,50	29,60	27,10	25,10
	15	M6	42,40	33,90	30,80	28,30	26,10
	20	M6	42,80	34,30	31,20	28,60	26,40
	25	M6	43,30	34,60	31,50	28,90	26,60
	30	M6	44,20	35,40	32,10	29,50	27,20
30	15	M6	45,30	36,30	32,90	29,81	27,40
	20	M6	47,60	38,10	34,60	31,70	29,30
	25	M6	49,10	39,30	35,70	32,70	30,20
	30	M6	50,60	40,50	36,80	33,70	31,10
	40	M6	53,40	42,70	38,80	35,60	32,90
40	20	M8	51,10	40,90	37,20	34,10	31,50
	30	M8	56,70	45,40	41,20	37,80	34,90
	40	M8	66,40	53,10	48,30	44,20	40,80
50	20	M10	75,50	60,40	54,90	50,30	46,40
	25	M10	78,30	62,60	56,90	52,20	48,20
	30	M10	82,70	66,20	60,20	55,20	50,90
	35	M10	86,30	69,00	62,70	57,50	53,10
	40	M10	90,00	72,00	65,50	60,00	55,40
	45	M10	93,00	74,40	67,60	62,00	57,20
	50	M10	97,30	77,80	70,70	64,80	59,90
60	30	M12	110,20	88,20	80,20	73,50	67,80
	40	M12	112,60	90,10	81,90	75,10	69,30
70	35	M12	130,40	105,90	96,30	88,30	81,50
	45	M12	139,70	111,70	101,60	93,10	86,00
75	25	M12	167,00	133,60	121,50	111,40	102,80
	40	M12	191,00	152,80	138,90	127,30	117,60
	50	M12	210,00	168,00	152,70	140,00	129,20
	55	M12	220,70	176,50	160,50	158,00	135,80
100	30	M16	330,80	264,60	240,60	220,50	203,60
	40	M16	341,30	273,00	248,20	227,50	210,00
	50	M16	373,40	298,70	271,60	248,90	229,80
	55	M16	385,10	308,10	280,10	256,70	237,00
	60	M16	399,70	319,70	290,70	266,40	245,90
	75	M16	443,50	354,80	322,60	295,70	272,90
150	45	M16	941,10	752,90	684,50	627,40	579,20
	50	M16	979,10	783,30	721,10	652,70	602,50
	55	M16	1008,30	806,60	733,30	672,20	620,50
	60	M16	1043,40	834,70	758,80	695,60	642,10
	75	M16	1142,70	914,20	831,10	761,80	703,20

SILENTBLOCK - TYP D

SINGLE-SIDED OUTDOOR THREAD

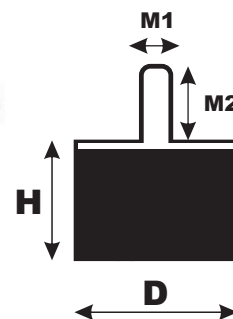

D	H	M1xM2	1 - 9 ks	10 - 24 ks	25 - 49 ks	50 - 99 ks	100 - 199 ks
15	8	M4x10	11,30	9,00	8,20	7,50	6,90
	10	M4x10	12,20	9,70	8,80	8,10	7,50
	15	M4x10	12,20	9,70	8,80	8,10	7,50
	20	M4x10	12,30	9,80	8,90	8,20	7,60
	30	M4x10	12,40	9,90	9,00	8,30	7,60
20	8	M6x18	14,90	11,90	10,80	9,90	9,20
	10	M6x18	15,10	12,10	11,00	10,10	9,30
	13,5	M6x18	15,50	12,40	11,20	10,70	9,50
	15	M6x18	15,70	12,50	11,40	10,50	9,70
	20	M6x18	16,60	13,30	12,10	11,10	10,20
	25	M6x18	17,20	13,70	12,50	11,40	10,60
	30	M6x18	17,70	14,20	12,90	11,30	10,90
25	10	M6x18	19,20	15,40	14,00	12,80	11,80
	15	M6x18	20,70	16,50	15,00	13,80	12,70
	20	M6x18	20,90	16,70	15,20	13,90	12,90
	25	M6x18	21,80	17,50	15,90	14,50	13,40
30	30	M6x18	22,70	18,20	16,50	15,20	14,00
	15	M6x18	23,60	19,90	18,40	17,30	14,50
	20	M6x18	26,40	21,10	19,20	17,60	16,20
	25	M6x18	27,80	22,30	20,20	18,60	17,10
	30	M6x18	29,30	23,50	21,30	19,50	18,70
40	40	M6x18	32,30	25,80	23,50	21,50	19,90
	20	M8x23	28,00	22,40	20,30	18,60	17,20
	30	M8x23	32,60	26,10	23,70	21,70	20,10
	40	M8x23	44,10	35,30	32,10	29,40	27,10
50	20	M10x28	52,40	41,90	38,10	34,90	32,20
	25	M10x28	55,20	44,20	40,20	36,80	34,00
	30	M10x28	59,70	47,70	43,40	39,80	36,70
	35	M10x28	63,20	50,50	46,00	42,10	38,90
	40	M10x28	66,90	53,50	48,70	44,60	41,20
	45	M10x28	69,90	55,90	50,80	46,60	43,00
	50	M10x28	74,20	59,40	54,00	49,50	45,70
60	30	M12x37	77,20	61,70	56,10	51,40	47,50
	40	M12x37	78,00	62,40	56,70	52,00	48,00
70	35	M12x32	98,90	79,10	71,90	65,90	60,80
	45	M12x32	106,10	84,90	77,20	70,80	65,30
75	25	M12x37	134,80	107,80	98,00	89,80	82,90
	40	M12x37	158,80	123,70	115,50	105,80	97,70
	50	M12x37	177,70	142,20	129,30	118,50	109,40
	55	M12x37	188,40	150,70	137,00	125,60	115,90
100	30	M16x42	268,50	214,80	195,30	179,00	165,20
	40	M16x42	289,90	231,90	210,80	193,30	178,40
	50	M16x42	321,90	257,50	234,10	214,60	198,10
	55	M16x42	333,60	266,90	242,60	222,40	205,30
	60	M16x42	348,30	278,60	253,30	232,20	214,30
	75	M16x42	392,00	313,60	285,10	261,40	241,30
150	45	M16x42	717,20	573,70	521,60	478,10	441,30
	50	M16x42	755,10	604,10	549,20	503,40	464,70
	55	M16x42	784,30	627,50	570,40	522,90	482,70
	60	M16x42	846,40	655,50	596,00	546,30	504,30
	75	M16x42	918,80	735,00	668,20	612,50	565,40

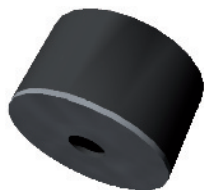
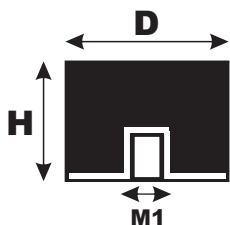

SILENTBLOCK - TYP E

SINGLE- SIDED INDOOR THREAD

D	H	M1	1 - 9 ks	10 - 24 ks	25 - 49 ks	50 - 99 ks	100 - 199 ks
15	8	M4	18,40	14,70	13,40	12,30	11,60
	10	M4	19,20	15,40	14,00	12,80	11,80
	15	M4	19,20	15,40	14,00	12,80	11,80
	20	M4	19,30	15,50	14,00	12,90	11,90
	30	M4	19,50	15,60	14,20	13,00	12,00
20	8	M6	24,70	19,70	17,90	16,40	15,20
	10	M6	24,90	19,90	18,10	16,60	15,30
	13,5	M6	25,20	20,20	18,30	16,80	15,50
	15	M6	25,50	20,40	18,50	17,00	15,70
	20	M6	26,40	21,10	19,20	17,60	16,20
	25	M6	26,90	21,50	19,60	18,00	16,60
	30	M6	27,50	22,00	20,00	18,30	16,90
25	10	M6	28,30	22,60	20,60	18,90	17,40
	15	M6	29,90	23,90	21,70	19,90	18,40
	20	M6	30,10	24,10	21,90	20,10	18,50
	25	M6	31,00	24,80	22,60	20,70	19,10
	30	M6	31,80	25,50	23,10	21,20	19,60
30	15	M6	31,20	25,20	23,50	22,10	19,80
	20	M6	33,50	26,80	24,40	22,30	20,60
	25	M6	35,00	28,00	25,50	23,30	21,50
	30	M6	36,50	29,20	26,50	24,30	22,40
	40	M6	39,40	31,50	28,70	26,30	24,30
40	20	M8	34,80	27,80	25,30	23,20	21,40
	30	M8	39,70	31,70	28,80	26,40	24,40
	40	M8	52,00	41,60	37,90	34,70	32,00
50	20	M10	59,40	47,50	43,20	39,60	35,70
	25	M10	62,40	49,90	45,40	41,60	38,40
	30	M10	66,70	53,40	48,50	44,50	41,00
	35	M10	70,20	56,20	51,10	46,80	43,20
	40	M10	74,10	59,30	53,90	49,40	46,00
	45	M10	76,90	61,50	56,00	51,30	47,30
	50	M10	81,40	65,10	59,20	54,20	50,10
60	30	M12	81,70	65,40	59,40	54,50	50,30
	40	M12	82,60	66,10	60,10	55,10	50,80
70	35	M12	103,40	81,50	75,20	68,90	63,60
	45	M12	110,80	88,60	80,60	73,90	68,20
75	25	M12	139,40	111,50	101,40	93,00	85,80
	40	M12	163,40	130,70	118,80	108,90	100,60
	50	M12	182,40	145,90	132,60	121,60	112,20
	55	M12	191,40	153,10	139,20	127,60	117,80
100	30	M16	270,70	216,50	196,90	180,50	166,60
	40	M16	291,90	233,50	212,30	194,60	179,70
	50	M16	324,10	259,30	235,70	216,10	199,40
	55	M16	335,80	268,60	244,20	223,90	206,60
	60	M16	350,60	280,30	254,80	233,60	215,60
	75	M16	394,20	315,40	286,70	262,80	242,60
150	45	M16	719,20	575,40	523,10	479,50	442,60
	50	M16	757,30	605,80	550,70	504,80	466,00
	55	M16	786,50	629,20	572,00	524,30	484,00
	60	M16	821,50	657,20	597,40	547,70	505,50
	75	M16	920,80	736,60	669,70	613,90	566,60

With their mechanical, physical, chemical properties and permanent deformation, the cords are designed to seal structural and constructive parts in various industries.

They are air-tight and have virtually no water absorption. In the temperature range according to the material used they resist weathering without changing physical, mechanical and chemical properties

Sealing cords are made from the following materials:

- rubber (EPDM, NBR, VITON, CR, SILICONE)
- foam rubber (CR, EPDM, NBR, SILICONE)
- other materials upon request

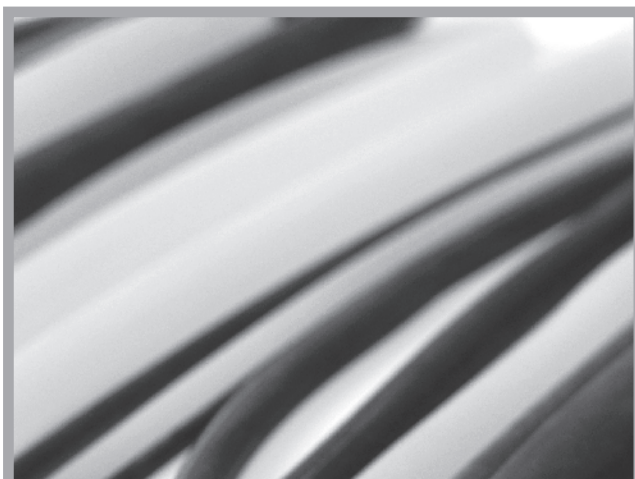

CORDS

SILICONE / FPM / EPDM / NBR / FOAM

Silicone cords		Price				
⊗ diameter	0,01 - 49,99 bm	50,00 - 99,99 bm	100,00 - 249,99 bm	250,00 - 499,99 bm	od 500,00 bm	
3 mm	7,08	5,31	3,54	3,54	3,04	
4 mm	9,96	7,97	7,24	6,64	5,69	
5 mm	15,27	12,22	11,11	10,18	8,73	
6 mm	17,53	15,94	14,61	13,49	12,52	
7 mm	18,59	16,90	15,49	14,30	13,28	
8 mm	20,19	18,35	16,82	15,53	14,42	
9 mm	25,50	23,18	21,25	19,62	18,21	
10 mm	28,49	26,12	24,11	22,39	20,90	
11 mm	34,29	31,43	29,01	26,94	25,15	
12 mm	37,63	34,74	32,25	30,10	28,22	
13 mm	43,83	40,46	37,57	35,06	32,87	
14 mm	50,91	47,00	43,64	40,73	38,18	
15 mm	58,44	53,94	50,09	46,75	43,83	
16 mm	66,85	61,71	57,30	53,48	50,14	

FPM cords		Price			
⊗ diameter	0,01 - 24,99 bm	25,00 - 99,99 bm	100,00 - 199,99 bm	od 200,00 bm	
2 mm	19,81	18,28	16,98	15,85	
3 mm	35,53	32,79	30,46	28,42	
4 mm	59,14	54,60	50,70	47,32	
5 mm	89,23	82,36	76,48	71,39	
6 mm	120,67	111,39	103,43	96,55	
7 mm	160,08	147,77	137,21	128,07	
8 mm	207,25	191,31	177,64	165,81	
10 mm	321,33	296,61	275,42	257,06	
12 mm	397,49	366,91	340,70	317,99	
15 mm	620,73	572,98	532,05	496,58	

EPDM cords		Price			
⊗ diameter	0,01 - 49,99 bm	50,00 - 99,99 bm	100,00 - 499,99 bm	od 500,00 bm	
2 mm	7,41	5,19	4,32	3,80	
3 mm	9,29	6,51	5,42	4,77	
4 mm	10,00	7,00	5,83	5,13	
5 mm	16,24	11,36	9,47	8,33	
6 mm	21,88	15,32	12,76	11,23	
7 mm	27,53	19,27	16,06	14,13	
8 mm	32,82	22,98	19,15	16,85	
9 mm	37,65	26,35	21,96	19,33	
10 mm	42,12	29,48	24,57	21,65	
12 mm	72,35	50,65	42,21	37,14	

CORDS

SILICONE / FPM / EPDM / NBR / FOAM



NBR cords		Price			
⊗ diameter	0,01 - 49,99 bm	50,00 - 99,99 bm	100,00 - 499,99 bm	od 500,00 bm	
2 mm	7,41	5,19	4,32	3,80	
3 mm	9,29	6,51	5,42	4,77	
4 mm	10,00	7,00	5,83	5,13	
5 mm	16,24	11,36	9,47	8,33	
6 mm	21,88	15,32	12,76	11,23	
7 mm	27,53	19,27	16,06	14,13	
8 mm	32,82	22,98	19,15	16,85	
9 mm	37,65	26,35	21,96	19,33	
10 mm	42,12	29,48	24,57	21,65	
12 mm	72,35	50,65	42,21	37,14	

foam EPDM		Price			
⊗ diameter	0,01 - 49,99 bm	50,00 - 99,99 bm	100,00 - 249,99 bm	od 250,00 bm	
2 mm	3,47	3,18	2,93	2,72	
3 mm	3,81	3,47	3,18	2,93	
4 mm	5,08	4,62	4,24	3,91	
5 mm	6,35	5,78	5,29	4,89	
6 mm	7,06	6,35	5,78	5,29	
7 mm	8,05	7,32	6,71	6,19	
8 mm	10,59	9,63	8,82	8,14	
9mm	13,13	11,94	10,94	10,10	
10 mm	16,52	15,05	13,76	12,71	
12 mm	21,18	19,25	17,65	16,29	
13mm	24,99	22,72	20,82	19,22	
14mm	28,80	26,18	24,00	22,15	
15 mm	33,04	30,03	27,53	25,41	
16mm	37,69	34,27	31,41	29,00	
17mm	42,78	38,89	35,65	32,90	
18mm	47,86	43,51	39,88	36,81	
20mm	58,87	53,52	49,06	45,29	
25mm	76,66	69,69	63,88	58,97	
30mm	110,54	100,49	92,12	85,03	
35mm	150,35	136,68	125,29	115,66	
40mm	196,52	178,65	163,76	151,17	
45mm	248,61	226,01	207,18	191,21	
50mm	307,06	279,14	255,88	236,20	

Hoses are made of different materials for different applications. Hydraulic hoses are made of synthetic rubber, which is resistant to oils and weather conditions.

Silicone hoses are mainly used in the food and pharmaceutical industries, e.g. for the transport of milk and alcohol.

We also manufacture PVC hoses:

- garden irrigation hoses in various designs
- single-layer hoses for light industrial, agricultural and domestic applications for air and water transport
- suction hoses used e.g. in agriculture, industry, etc.

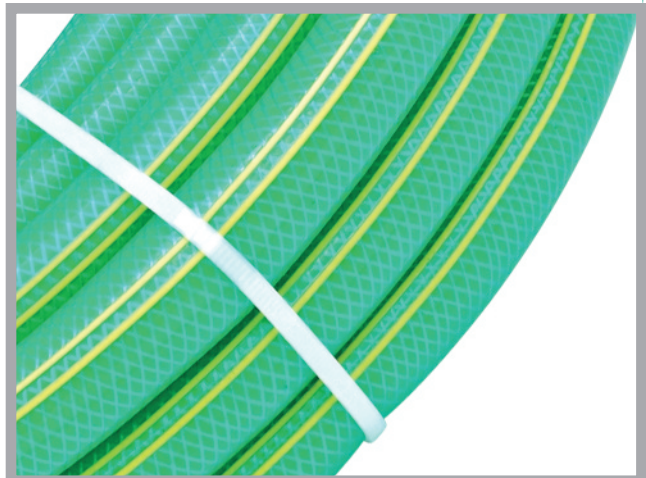
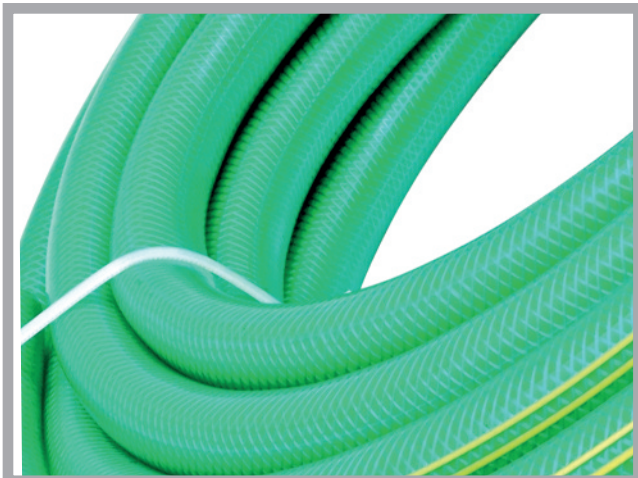

HOSES - GARDEN



...Immediate sealing effect

PVC - GARDEN HOSES

Materia: Softened PVC, black inner layer, dark green cover with yellow strip.

Application: ŠA widely used hose in industries and households for irrigation, water and air. Lightweight, flexible, elastic, portable and has great versatility.

Operating temperature: -5 ° C to +65 ° C

Dimension	⌀ inner diameter	⌀ outer diameter	packaging	⌚ work pressure	⌚ failure pressure	price/bm
1/2"	12,7	17,1	25/50bm	10	32	10,90
5/8"	15,9	20,9	25/50bm	10	28	15,80
3/4"	19,0	25,6	25/50bm	10	25	22,00
1"	25,4	34,4	25/50bm	10	18	36,40



PVC - HOSES WITH TEXTILE COVERING

Material: Softened PVC, clear inner layer, light green or light over layer (according to offer)

Application: Pressure hose for liquids and air, used for irrigation, horticulture, water transport in industry and agriculture, households. It is flexible, resistant, non-toxic, odorless.

Operating temperature: -5 ° C to +65 ° C

Dimension	⌀inner diameter	⌀outer diameter	packaging	⌚ work pressure	⌚ failure pressure	price/bm
5/16"	7,9	12,3	25/50bm	10	35	10,50
3/8"	9,5	13,9	25/50bm	10	32	10,60
1/2"	12,7	17,1	25/50bm	10	32	12,00
5/8"	15,9	20,9	25/50bm	10	28	21,30
3/4"	19,0	24,0	25/50bm	10	25	26,40
1"	25,4	32,0	25/50bm	10	18	37,50
5/4"	31,8	39,0	25/50bm	10	15	59,30

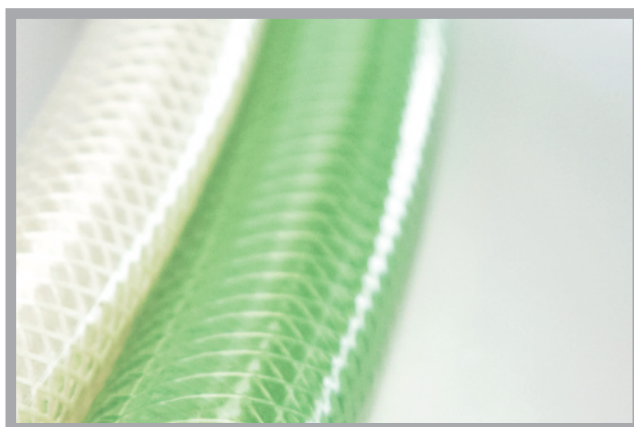

PVC – SUCTION HOSES WITH PLASTIC SPIRAL

Material: Softened PVC, transparent green

Application: Intended for suction and discharge of water and other non-aggressive liquids.

Used in industry, agriculture, irrigation and construction. It is an ideal alternative for rubber hoses and metal pipes.

Operating temperature: -5 ° C to +65 ° C

Dimension	inner diameter	outer diameter	packagin	work pressure	failure pressure		price/bm
3/4"	20	23,8	30bm	6	20	AV	19,80
1"	25	29,2	30bm	6	20	AV	23,90
1 1/4"	32	36,4	30bm	6	20	AV	28,80
1 1/2"	38	43,2	30bm	6	20	AV	43,10
2"	50	56	30bm	6	20	AV	64,40
3"	76	80,8	30bm	6	20	AV	128,90
4"	102	118	20bm	3	11	A	188,70
5"	125	140	20bm	3	11	A	290,60
6"	152	170	10bm	2	8	A	425,40
8"	203	225	10bm	2	8	A	590,80

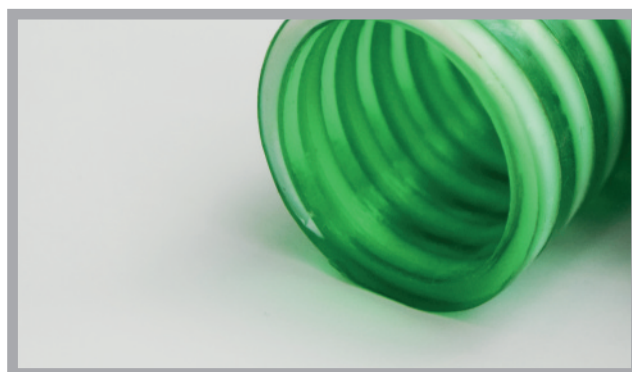
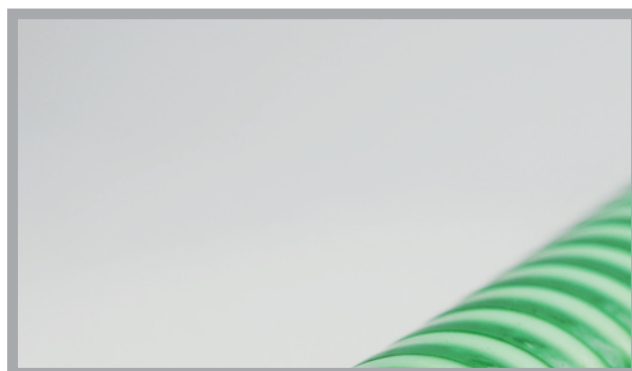

HOSES - WITH METAL SPIRAL

PVC - HOSES WITH METAL SPIRAL

Material: Softened PVC

Application: The hose is used for pumping and transporting water, oil and dust in factories, agriculture, mechanical engineering, food processing and sewer pipes. The hose used for food is made of special materials. It is non-toxic, light, odorless and transparent. The hose can be used to transport milk, beverages, distilled alcohol, beer, jam and other materials. We can also put copper wire into the hose. This hose can prevent static electricity flow and protect the user from electric shock. The product is used for transporting liquids, water and air.

Operating temperature: -5 ° C to +65 ° C

Dimension	⌀ inner diameter	⌀ outer diameter	packagin	⌚ work pressure	⌚ failure pressure		price/bm
3/8"	9	14	50bm	4	12	A	15,40
1/2"	12	17	50bm	4	12	A	17,40
5/8"	16	20	50bm	4	12	A	24,40
3/4"	19	25,6	50bm	4	9	A	26,20
1"	25	33	30bm	5	15	AV	26,40
1 1/4"	32	40,2	30bm	5	15	AV	37,50
1 1/2"	38	46,8	30bm	4	12	AV	59,30
2"	51	61,4	30bm	3	9	AV	98,90
3"	63	75	30bm	2	6	AV	197,10
4"	102	110	30bm	1,5	4,5	A	326,20
5"	125	141	20bm	1,5	4,5	A	477,30
6"	152	166	10bm	1,5	4,5	A	715,90
7"	180	196	10bm	1,5	4,5	A	805,70
8"	200	224	10bm	1,5	4,5	A	1.055,30



HOSES - SINGLE LAYER



...Immediate sealing effect

PVC - SINGLE LAYER HOSE

Material: Softened PVC, transparent / clear

Application: The product is used for transport of liquids, water and air. Designed for easy use in industry, agriculture and households. It is flexible, resistant, non-toxic, odorless.

Operating temperature: -5 ° C to +65 ° C

⌀ inner diameter	⌀ outer diameter	packagin	⌚ work pressure	⌚ failure pressure		price/bm
3	5	100bm	4	12	A	2,80
4	7	100bm	4	12	AV	6,20
5	8	100bm	4	12	AV	6,30
6	9	100bm	4	9	AV	6,40
7,9	10,9	100bm	5	15	AV	6,70
9,5	12,5	100bm	5	15	AV	8,20
12,5	15,9	50bm	4	12	AV	12,20
15,9	19,7	50bm	2	6	AV	15,95
19	23	50bm	1,5	4,5	AV	20,50
25,4	30,8	25bm	1,5	4,5	AV	34,50
34	36	40bm	1,5	4,5	A	36,20
38	43	40bm	1,5	4,5	A	39,20
51	57	40bm	1,5	4,5	A	68,80

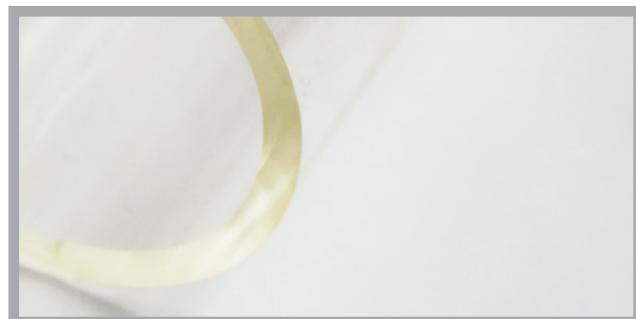
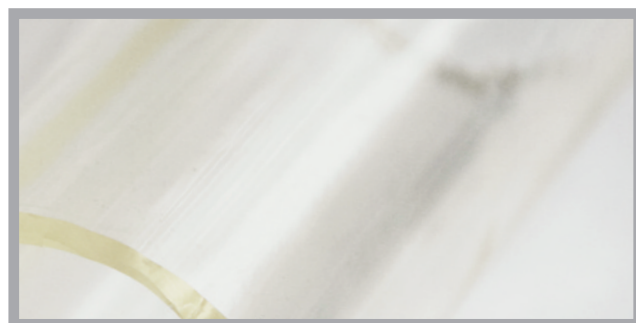



HOSES - SILICONE



HOSES

Hose - material silicone 60 +/- 5Sh., Transp.					
Dimension	Price				
	0,01 - 49,99 rm	50,00 - 99,99 rm	100,00 - 249,99 rm	250,00 - 499,99 rm	od 500,00 rm
1 x 1mm	4,60	3,70	3,10	2,70	2,50
2 x 1mm	7,30	5,80	4,90	4,20	3,90
3 x 1mm	10,00	8,00	6,60	5,70	5,30
4 x 1mm	12,00	9,60	8,00	6,80	6,40
5 x 1mm	16,60	11,70	9,70	8,30	7,80
6 x 1mm	17,30	13,80	11,50	9,90	9,20
7 x 1mm	19,30	15,40	12,80	11,00	10,30
8 x 1mm	21,90	17,50	14,60	12,50	11,70
9 x 1mm	24,60	19,70	16,40	14,00	13,10
10 x 1mm	17,30	13,80	11,50	9,90	9,20
11 x 1mm	19,30	15,40	12,80	11,00	10,30
12 x 1mm	20,60	16,50	13,70	11,80	11,00
Dimension	0,01 - 49,99 rm	50,00 - 99,99 rm	100,00 - 249,99 rm	250,00 - 499,99 rm	od 500,00 rm
2 x 1,5mm	12,60	10,10	8,40	7,20	6,70
3 x 1,5mm	16,60	13,30	11,10	9,50	8,90
4 x 1,5mm	19,90	15,90	13,30	11,40	10,60
5 x 1,5mm	23,90	19,10	15,90	13,70	12,80
6 x 1,5mm	17,30	13,80	11,50	9,90	9,20
7 x 1,5mm	19,90	15,90	13,30	11,40	10,60
8 x 1,5mm	22,60	18,10	15,10	12,90	12,00
9 x 1,5mm	24,60	19,70	16,40	14,00	13,10
10 x 1,5mm	27,20	21,80	18,20	15,60	14,50
11 x 1,5mm	29,20	23,40	19,50	16,70	15,60
12 x 1,5mm	31,90	25,50	21,30	18,20	17,00
Dimension	0,01 - 49,99 rm	50,00 - 99,99 rm	100,00 - 249,99 rm	250,00 - 499,99 rm	od 500,00 rm
2 x 2mm	12,60	10,10	8,40	7,20	6,70
3 x 2mm	15,90	12,80	10,60	9,10	8,50
4 x 2mm	18,60	14,90	12,40	10,60	9,90
5 x 2mm	21,90	17,50	14,60	12,50	11,70
6 x 2mm	25,20	20,20	16,80	14,40	13,50
7 x 2mm	27,90	22,30	18,60	15,90	14,90
8 x 2mm	31,20	25,00	20,80	17,80	16,60
9 x 2mm	34,50	27,60	23,00	19,70	18,40
10 x 2mm	37,90	30,30	25,20	21,60	20,20
11 x 2mm	40,50	32,40	27,00	23,10	21,60



PLOW BLADES

Blades for plowshares		Price				
Dimension	length max mm	0,1 - 39 rn	40 - 99 rn	100 - 199 rn	200 - 499 rn	od 500 rn
70x40 mm	10.000 mm	340,10	315,80	294,80	276,40	260,10
80x20 mm	10.000 mm	202,10	187,70	175,20	164,20	154,60
100x20 mm	10.000 mm	251,20	233,30	217,70	204,10	192,10
120x30 mm	10.000 mm	439,70	408,30	381,00	357,20	336,20
120x40 mm	10.000 mm	579,40	538,00	502,20	470,80	443,10
130x30 mm	10.000 mm	475,90	441,90	412,50	386,70	363,90
140x50 mm	10.000 mm	836,80	777,10	725,30	679,90	639,90
180x50 mm	10.000 mm	1.067,30	991,10	925,00	869,20	816,20
200x20 mm	10.000 mm	493,20	457,90	427,40	400,70	377,10
200x40 mm	10.000 mm	980,60	910,60	849,90	796,70	749,90
200x50 mm	10.000 mm	1.233,20	1.145,10	1.068,70	1.001,90	94,00
230x50 mm	10.000 mm	1.606,50	1.491,70	1.392,30	1.305,30	1.228,50
230x40 mm	10.000 mm	1.195,60	1.110,20	1.036,20	971,40	914,30
250x50 mm	10.000 mm	1.482,20	1.376,30	1.284,60	1.204,30	1.133,40
250x60 mm	10.000 mm	1.786,60	1.659,00	1.548,40	1.451,60	1.366,20

Material: SBR, 4x textile insert
 Hardness: 70 +/- 5 Sh.
 Black colour
 Elongation: > 400-500%
 Strength: 9-11 MPa

Note:

- abrasion resistant rubber
- up to 10,000 mm length
- We will supply you with blades with holes based on request
- we cut lengths at customer's request

Other materials according to specific demand (PU, EPDM, etc.)

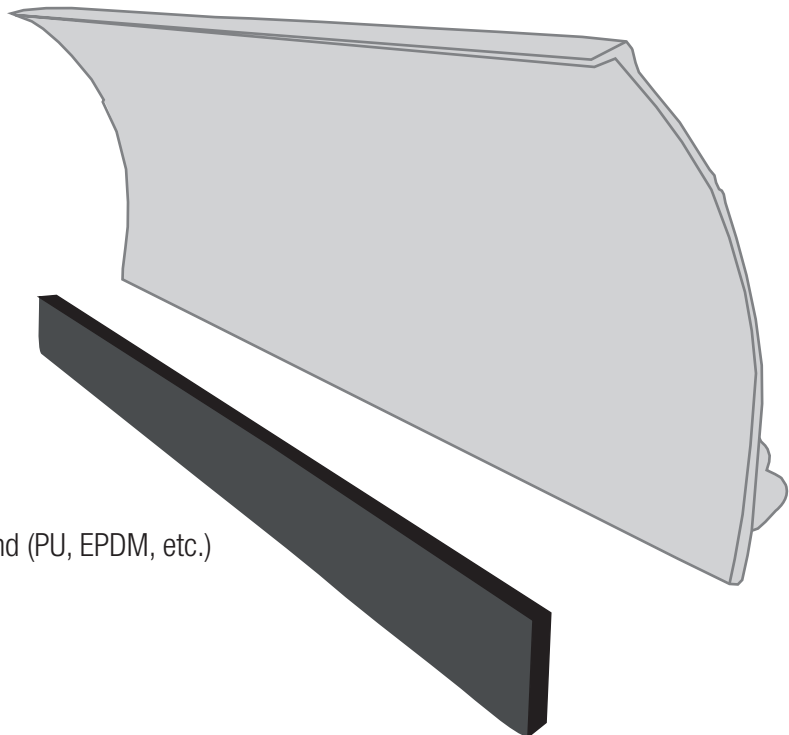

HANGING PVC STRIPS



They are used as a transparent screen for the separation of storage and production areas, garages, etc. They are particularly suitable due to safety reasons, noise or thermal insulation and hygiene.

The strips must overlap each other to prevent drafts or heat leakage. They have high abrasion resistance.

The transparency of plastic curtains improves lighting conditions and reduces lighting costs.

Material: plasticized transparent PVC

Operating temperature: -20 ° C / + 60 ° C

Hanging PVC strips	Price			
	0,01 - 9,99 rm	10 - 29,99 rm	25 - 99,99 rm	nad 100 rm
Dimension				
100 x 2 mm	34,60	29,90	28,10	26,40
200 x 2 mm	66,80	57,90	54,30	51,10
300 x 2 mm	99,10	85,90	80,50	75,80
100 x 3 mm	55,40	48,00	45,00	42,40
200 x 3 mm	103,40	89,60	84,00	79,10
300 x 3 mm	154,00	133,50	125,10	117,80
400 x 3 mm	204,50	177,30	166,20	156,40

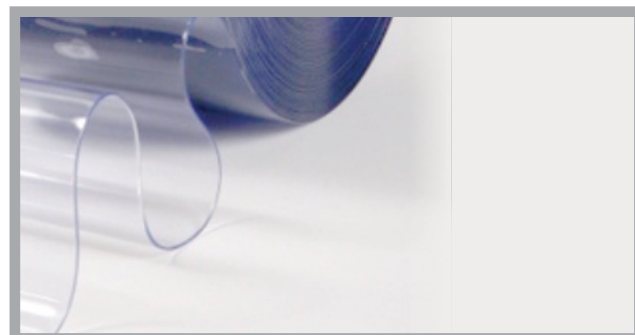
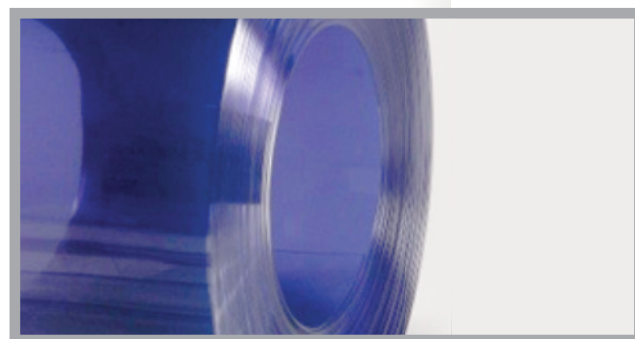

JACK PADS

We produce various types of pads for service and hand jacks of high quality rubber, which minimize the risk of damage to the sill of the vehicle.

The advantage is high durability and flexibility.

You will find both threading pads of various shapes as well as pads with screws or rubber pins.

threaded - Ø 115 mm



threaded square - Ø 118 mm



with screw holes M6 - Ø 125 mm



2x screw M6 - Ø 110 mm



2x M6 screw with reces - Ø 110 mm



with rubber pins and hole - Ø 140 mm



with three rubber pins - Ø 146 mm

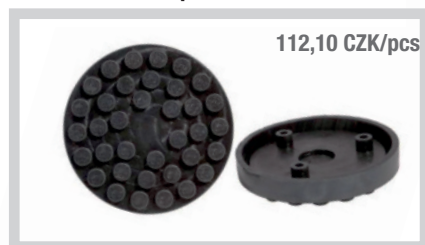

hole for screw 13mm - Ø 140 mm



small insertable U-profile- 120 mm



large insertable U-profile - 120 mm



HYDRAULIC SEALS



We offer custom-made seals for hydraulic machines.
We produce custom-made hydraulic seals and are able to provide expert advice and service according to the customer's wishes.

...Immediate sealing effect

- custom-made seals
- home-made
- extensive personal advice and service
- custom-made production on request and special technical solutions

...Immediate sealing effect

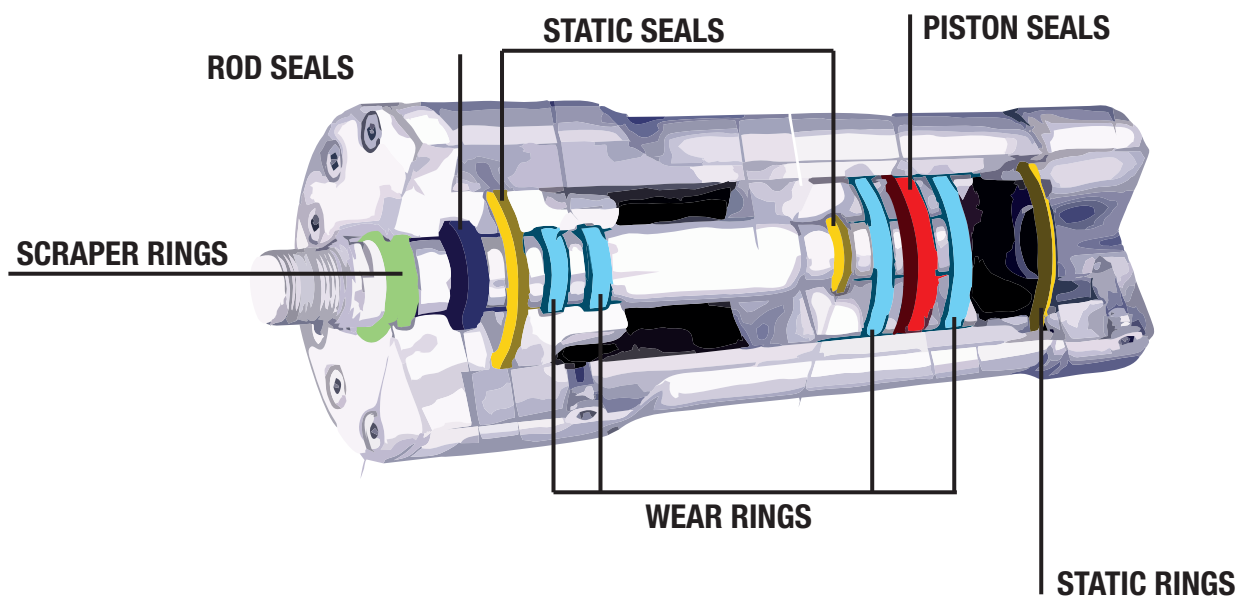

HYDRAULIC SEALS

SCRAPER RINGS

Scraper rings are built into the cylinder seal systems to wipe off dirt, foreign matter, shavings and moisture from the piston rod before returning to the cylinder. This prevents contamination of the hydraulic fluid, which could damage lines, seals and other components.

FACTORS FOR SELECTING SCRAPER RING GEOMETRY

- only wiping function or wiper seal function
- the type of pollution from the outdoor area
- maximum movement speed (linear or rotation)
- space needed in the construction area
- open or closed mounting area
- min./max. temperature range
- accurate media data (important for material selection)

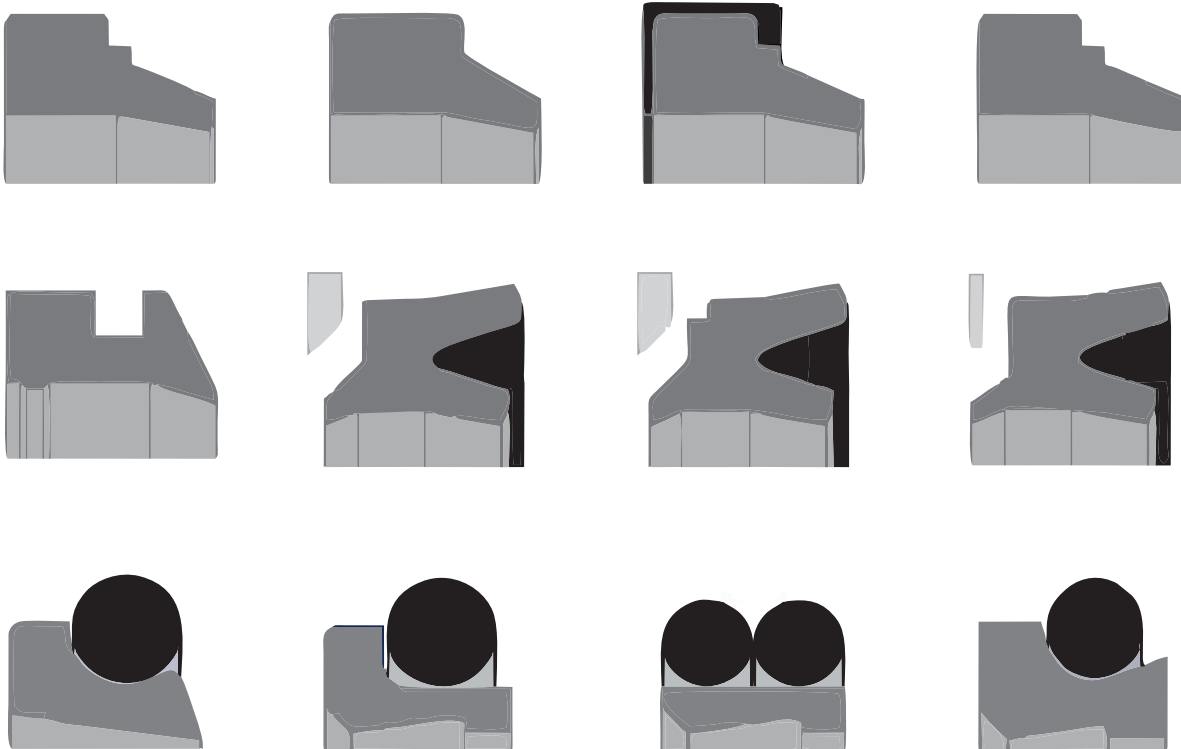

WE PRODUCE CUSTOM-MADE SCRAPER RINGS ON REQUEST. FOR MORE INFORMATION CONTACT US.

HYDRAULIC SEALS

ROD SEALS



The piston rod seal ensures that the system is leak-proof. The main effect of the seal is on the dynamic inner side of the seal. This keeps the piston rod space sealed and allows pressurization when the hydraulic or pneumatic cylinder is driven in. Without a piston rod seal, no double-acting hydraulic or pneumatic system would be able to operate (exception: systems with sealing pullers).

FACTORS FOR SELECTING ROD SEALS

- space needed in the construction area
- scope of application of the system
- maximum feed rate
- accurate dimensions of the extrusion joint
- maximum pressure load
- open or closed mounting area
- min./max. temperature
- accurate media data (important for material selection)

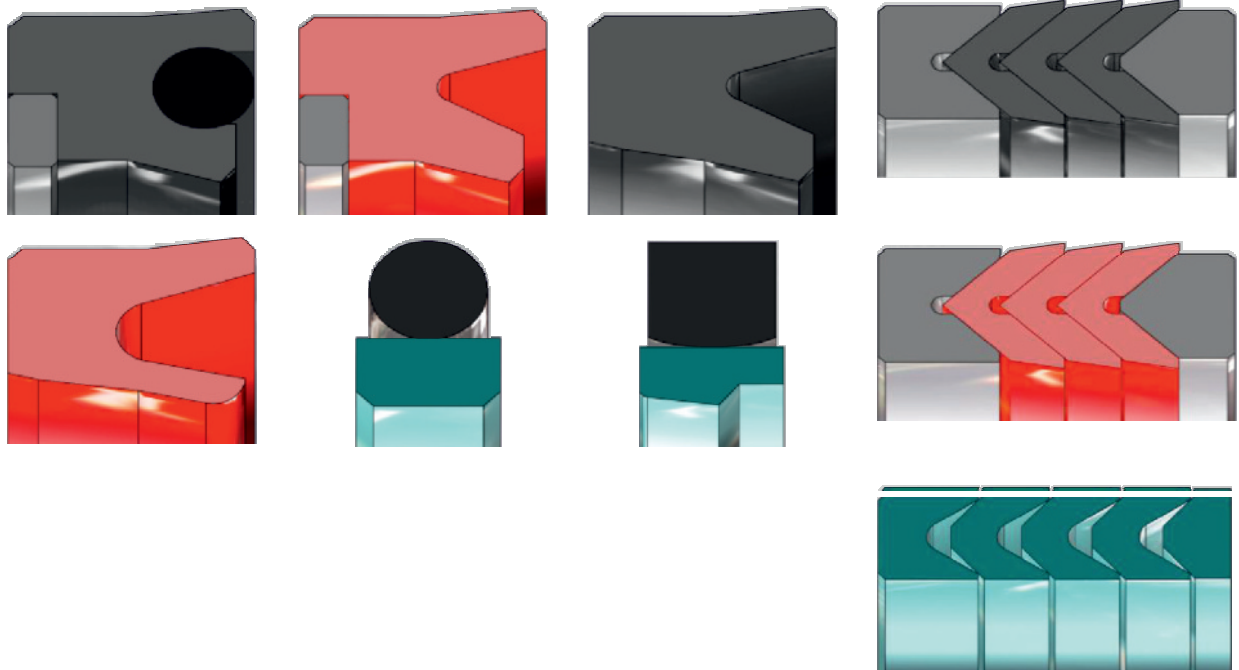

WE PRODUCE CUSTOM-MADE ROD SEALS ON REQUEST. FOR MORE INFORMATION CONTACT US.

HYDRAULIC SEALS

WEAR RINGS

The wear rings have the function of ensuring the exact alignment of the piston rod in the cylinder. As guiding elements, they are very important construction components in a complete sealing system.

Without accurate guidance, the service life of the rod seal or the piston would be greatly reduced.

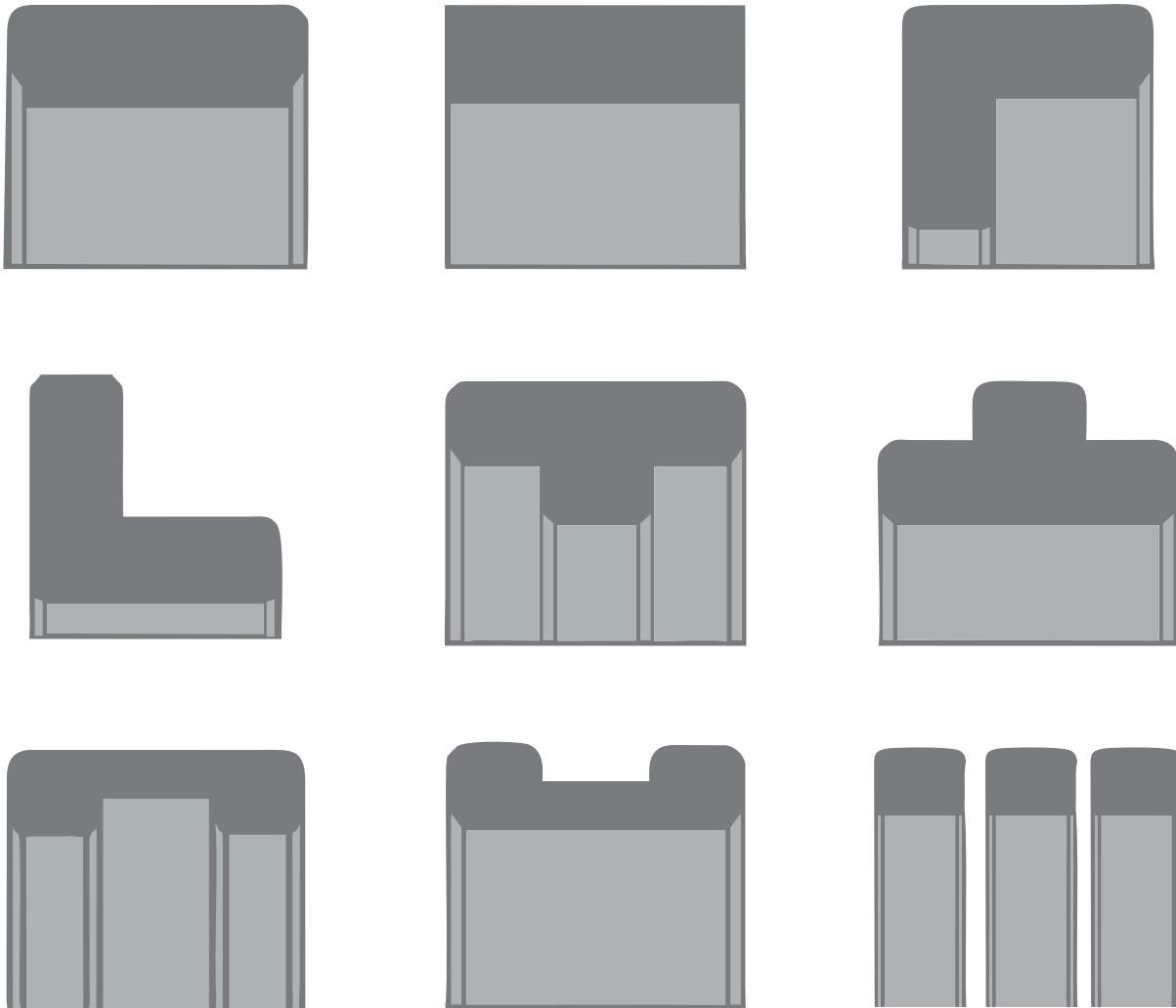

WE PRODUCE CUSTOM-MADE WEAR RINGS ON REQUEST. FOR MORE INFORMATION CONTACT US.

HYDRAULIC SEALS

PISTON SEALS



The piston seal provides a dynamic and static seal between the piston (outside diameter) and the cylinder tube.

FACTORS FOR SELECTING PISTON SEALS

- single-acting or double-acting sealing system
- space needed in the construction area
- scope of application of the system
- maximum pressure load
- accurate dimensions of the extrusion joint
- maximum feed rate
- open or closed mounting area
- min./max. temperature
- accurate media data (important for material selection)

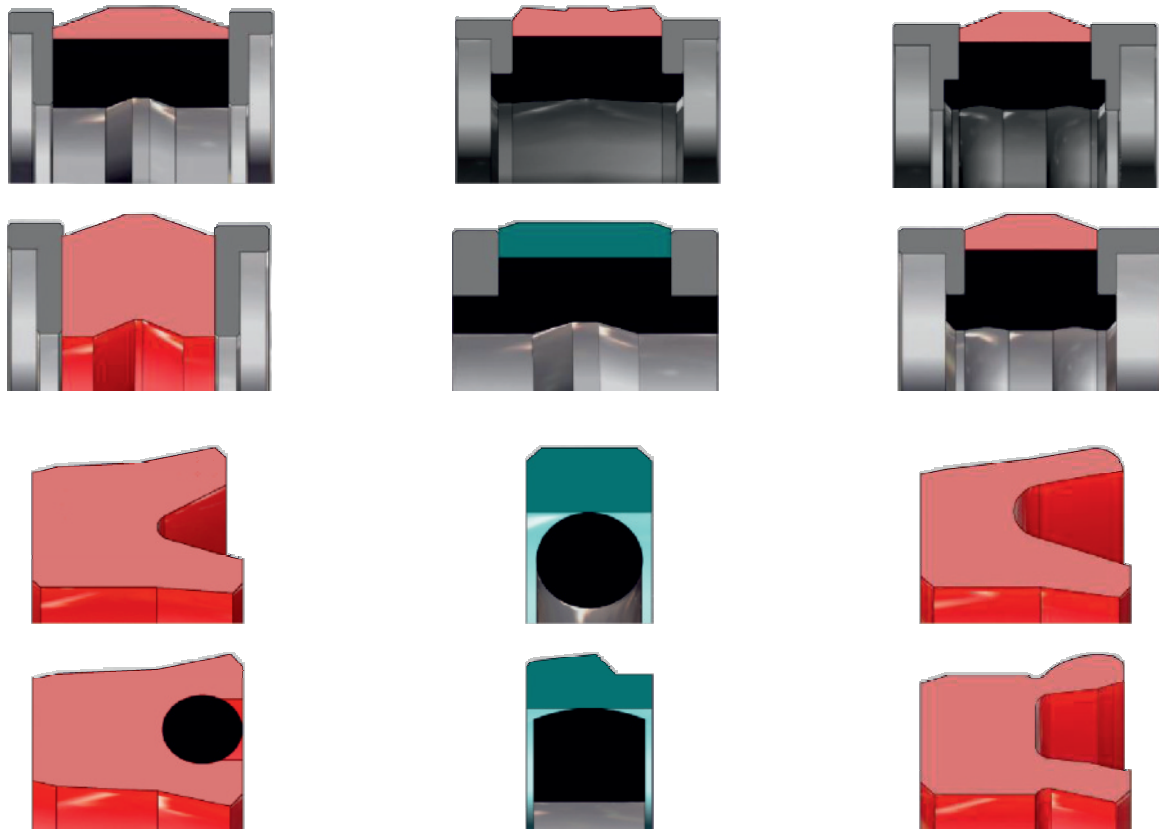

WE PRODUCE CUSTOM-MADE PISTON SEALS ON REQUEST. FOR MORE INFORMATION CONTACT US.

HYDRAULIC SEALS

STATIC SEALS

Static seals are generally used for static gaskets, for example on the inside of a piston or at screw connections of a tube head.

By offering a broad variety of geometries, designers in this area have a wide choice according to the needs of the application.

The selection of the geometry of the static seal is mainly a result of the system design.

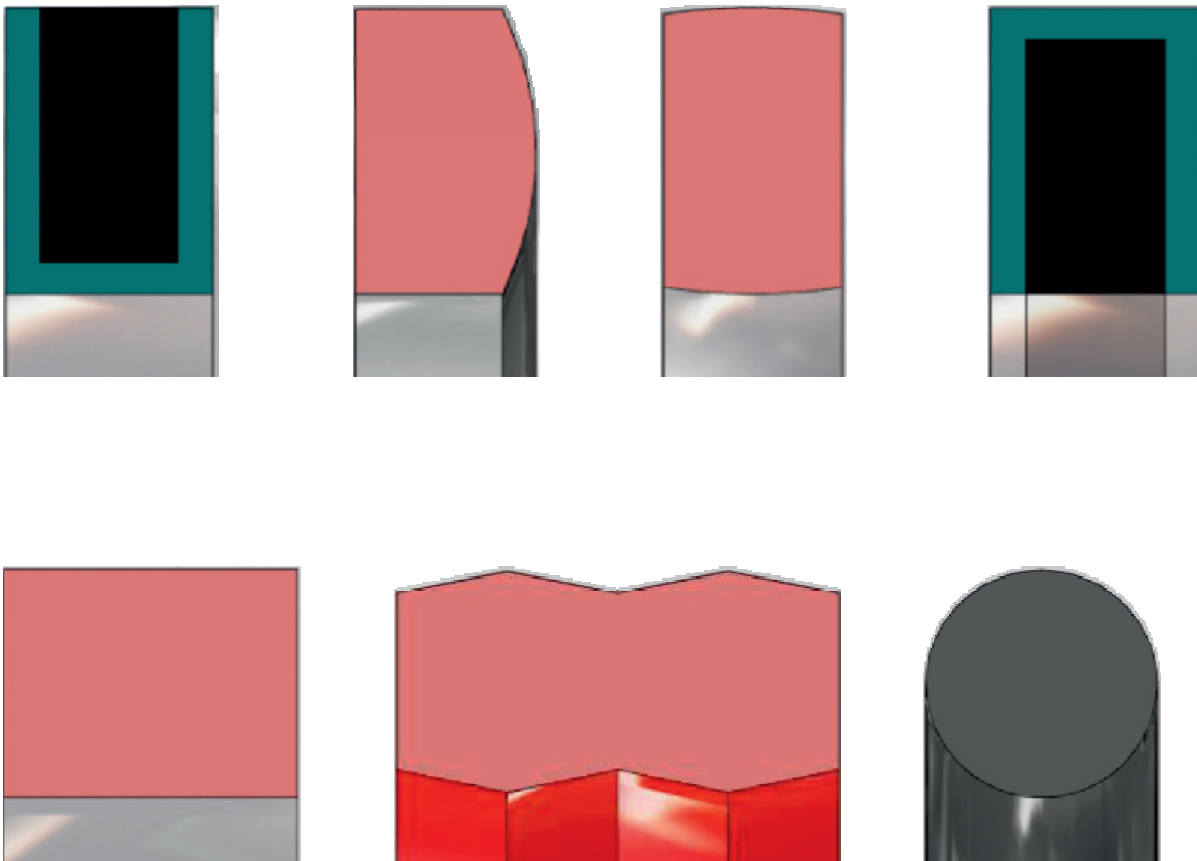

WE PRODUCE CUSTOM-MADE STATIC SEALS ON REQUEST. FOR MORE INFORMATION CONTACT US.

HYDRAULIC SEALS

RADIAL SHAFT SEALS



Radial shaft seal ensures that the rotating shaft, which is loaded by the oil bath from the inside, is sealed in an upward direction. This seems easy at first glance but considering all the operating conditions, we find it to be the most complicated.

FACTORS FOR SELECTING RADIAL SHAFT SEALS

- pollution loads in the surrounding area
- space needed
- open or closed mounting area
- Maximum RPM for calculation of the peripheral speed
- operating pressure or use without pressure
- material, roughness and hardness of the shaft surface
- min./max. temperature load
- accurate media data (important for material selection)

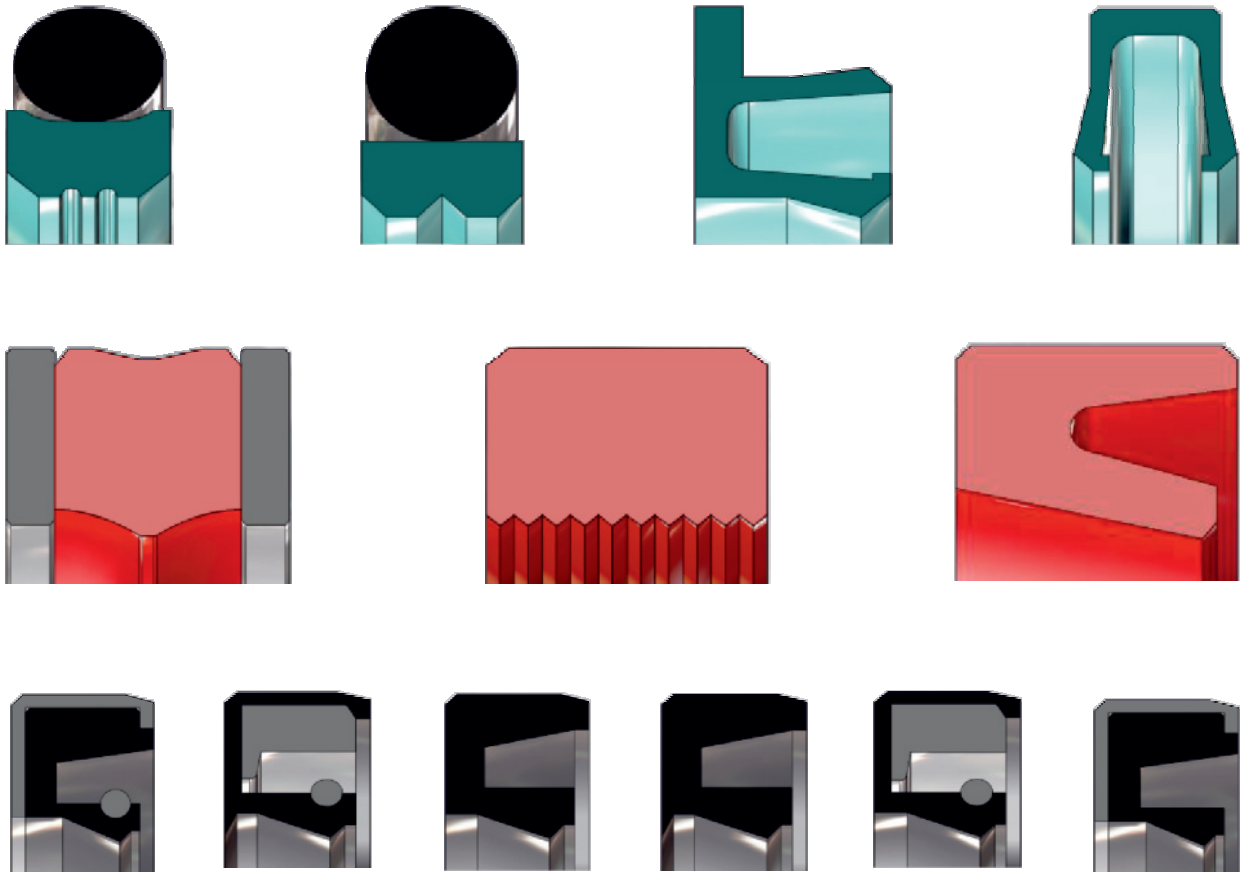

HYDRAULIC SEALS

BACK - UP RINGS

Back-up rings are mainly used to minimize the extrusion joint that results from the production or wear of metal parts.

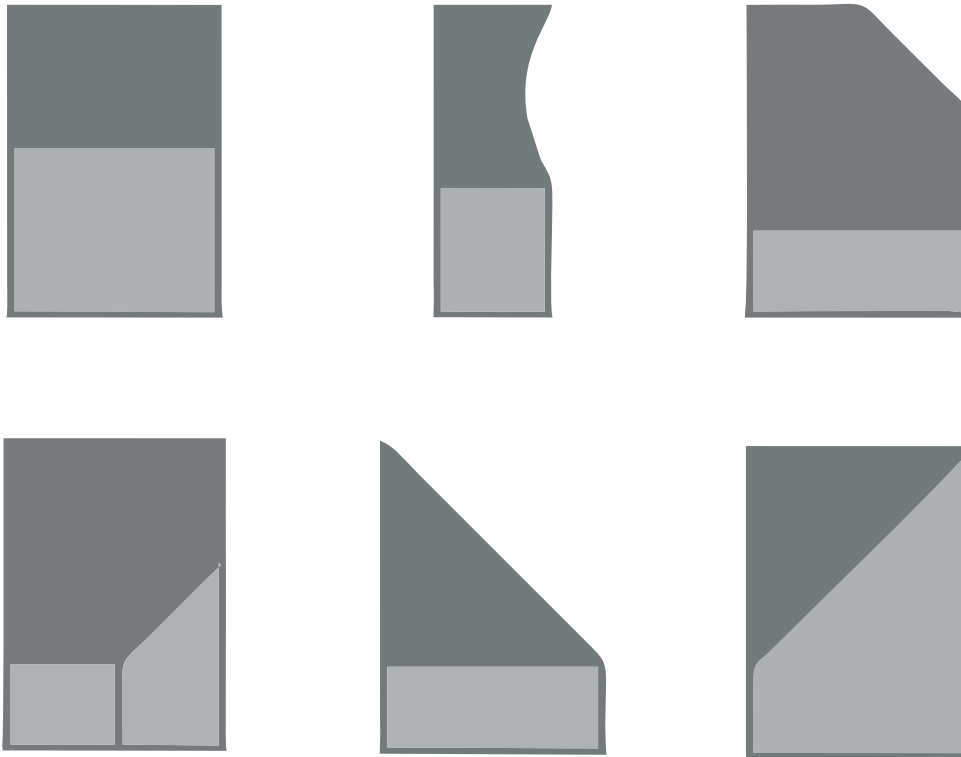

WATER SEAL



...Immediate sealing effect

WATER SEAL RINGS

MATERIAL: **ADISEAL** (Non-asbestos seal rings)

APPLICATION: water, gas, oils, alcohols, basic chemicals

CERTIFICATION: Germanischer Lloyd, KTW, Temp. 140-330 ° C

Water seal rings		Price		
Dimension	Dimension outer X inner	ADISEAL BEZAZBEST tl. 1.6 mm / 140 °C	ADISEAL BEZAZBEST tl. 2.0 mm / 140 °C	ADISEAL BEZAZBEST tl. 2.0 mm / 330 °C
1/4"	24 x 17 mm	0,83	0,89	2,20
3/8"	27 x 19 mm	0,96	1,04	2,40
1/2"	34 x 24 mm	1,25	1,42	2,99
3/4"	38 x 27 mm	1,45	1,62	3,70
1"	44 x 34 mm	1,90	1,90	4,95
5/4"	56 x 44 mm	2,69	2,65	6,30
6/4"	62 x 47 mm	3,15	3,30	6,95
2"	78 x 60 mm	4,05	4,40	10,10
2 1/2"	96 x 75 mm	6,20	6,80	14,85
3"	110 x 85 mm	7,80	8,50	16,95

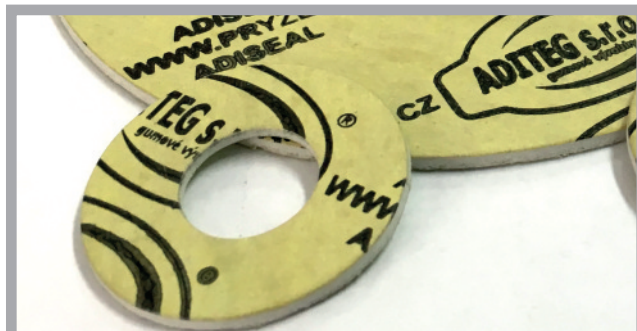
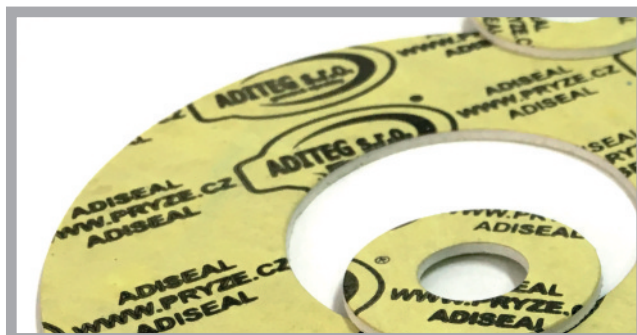

WATER SEAL RINGS

MATERIAL:

SBR - 65 +/- 5 Sh, black, 2-3 MPa

- temperature -30 ° C to + 80 ° C

SBR - FDA - temperature 65 +/- Sh. A, light, 5 MPa

- temperature -30 ° C to + 80 ° C

- food sheet - FDA

Food sheets consist of raw materials that are approved by the FDA standard, Title 21, Part 170-199, revised since April 1, 1998.

Water seal rings		Price		
Dimension	Dimension outer X inner	RUBBER/ SBR tl. 2 mm 2 - 3 MPa - do 80 °C	RUBBER / SBR tl. 3 mm 2 - 3 MPa - do 80 °C	RUBBER- food tl. 2 mm 5 MPa - do 80 °C
1/4"	24 x 17 mm	0,61	0,65	0,87
3/8"	27 x 19 mm	0,69	0,74	0,98
1/2"	34 x 24 mm	0,89	0,96	1,32
3/4"	38 x 27 mm	0,97	1,06	1,52
1"	44 x 34 mm	1,10	1,20	1,95
5/4"	56 x 44 mm	1,35	1,50	2,78
6/4"	62 x 47 mm	1,65	1,70	3,21
2"	78 x 60 mm	1,99	2,40	4,59
2 1/2"	96 x 75 mm	2,40	3,20	6,40
3"	110 x 85 mm	2,85	4,35	7,99



DIE-CUT PRODUCTS



...Immediate sealing effect

We produce the required seals and cut-outs from various materials:

- normal rubbers
- self-adhesive rubber
- plastic and insulating materials
- materials for high pressure applications
- foil

Depending on the customer's requirements, we also supply seals from other materials.

We offer die-cut rings with or without holes, seals according to drawings or designs, tapes, washers, blanks and other seals. The maximum size and thickness of the seal is determined by the availability of the materials used.



MOLDED PRODUCTS

The largest share of products is used in the automotive and engineering industries.

This group includes mainly:

O-rings, membranes, gaskets, cuffs, stops, rubber products, combined with metal (silentblocks) or only rubberised.

The materials used are from the most common such as NR or SBR before EPDM, NBR, CR to silicone and fluoromagnesium, in hardness of 30-90 ° C.

This wide range of rubber compounds allows us to satisfy all demands placed on rubber products such as resistance to oil, ozone, temperature, pressure, abrasion, chemical action, etc.

Material selection is possible according to mechanical and chemical conditions of the working environment.



O - RINGS



...immediate sealing effect

O-rings are sealing elements of circular cross-section which, due to their sealing properties, prevent unwanted loss of liquids or gases. The sealing effect is achieved by compressing the circular profile of the ring supported in the groove.

O-rings are used in removable joints to seal both stationary parts (covers, flanges, fittings) and moving parts in hydraulics and pneumatics (pistons, piston rods).

O-rings are versatile because they are simple, seal on both sides, do not require large installation space and are easy to install. For the given production we use both common materials and custom-made materials. There are hundreds of sizes of different materials, you can consult their use directly with our staff.

PROFILES

Profiles, due to their mechanical, physical, chemical properties and permanent deformation, are designed to seal structural and constructive parts in various industries. They are air-tight and have virtually no water absorption. In the temperature range according to the material used, they resist weathering without changing physical, mechanical and chemical properties. Profiles are produced in basic shapes as well as special shapes.

Depending on the customer's request, we produce profiles according to the submitted drawings.

The basic materials of the profiles are rubbers (EPDM, NBR, VITON, CR, SILICON) and foam rubbers (CR, EPDM, SILICON).

Other materials on request.



SILICONE PROFILES - SQUARE / RECTANGLE

Crude weight: 1,1 - 1,24g/cm³
 Ozone-UV / aging: excelent
 Shore A: 60 +/- 5
 Color: white
 Temperature: -60 degrees Celsius, +200 degrees Celsius
 Short-term temperature: +230 degrees Celsius
 Elongation at break > 350%
 Tensile strength DIN 53504 > 7 MPa

Square / rectangular profiles - silicone 60 +/- 5Sh., White

Dimension		price				
mm	mm	1,0 - 9,9 rm	10,0 - 24,9 rm	25,0 - 49,9 rm	50,0 - 99,9 rm	od 100,0 rm
3	6	13,80	11,80	10,30	8,30	6,90
3	10	22,90	19,70	17,20	13,80	11,50
3	20	45,90	39,30	34,40	27,50	22,90
3	25	57,40	49,20	43,00	34,40	28,70
4	6	18,40	15,70	13,80	11,00	9,20
4	8	24,50	21,00	18,40	14,70	12,20
5	5	19,10	16,40	14,30	11,50	9,60
5	10	38,20	32,80	28,70	22,90	19,10
5	15	57,40	49,20	43,00	34,40	28,70
5	20	76,50	65,50	57,40	45,90	38,20
5	25	95,60	81,90	71,70	57,40	47,80
6	6	27,20	23,60	20,60	16,50	13,80
6	8	36,70	31,50	27,50	22,00	18,40
6	10	45,0	39,30	34,40	27,50	22,90
6	15	68,80	59,00	51,60	41,30	34,40
8	8	48,90	41,90	36,70	29,40	24,50
8	11	67,30	57,70	50,50	40,40	33,60
8	15	91,80	78,70	68,80	55,10	45,90
8	20	122,40	104,90	91,80	73,40	61,20
10	10	76,50	65,50	57,40	45,90	38,20
10	12	91,80	78,70	68,80	55,10	45,90
10	15	114,70	98,30	86,00	68,80	57,40
10	20	152,90	131,10	114,70	91,80	76,50
10	30	229,40	196,60	172,10	137,60	114,70
12	12	11,10	94,40	82,60	66,10	55,10
12	20	183,50	157,30	137,60	110,10	91,80
14	14	149,90	128,50	112,40	89,90	74,90
15	15	172,10	147,50	129,00	103,20	86,00
15	20	229,40	196,60	172,10	137,60	114,70
15	25	286,80	245,80	215,10	172,10	143,40
15	30	344,10	295,00	258,10	206,50	172,10
20	20	305,90	262,20	229,40	183,50	152,90
20	30	458,80	393,30	344,10	275,30	229,40
25	25	477,90	409,70	358,50	286,80	239,00
30	30	688,20	589,90	516,20	412,90	344,10

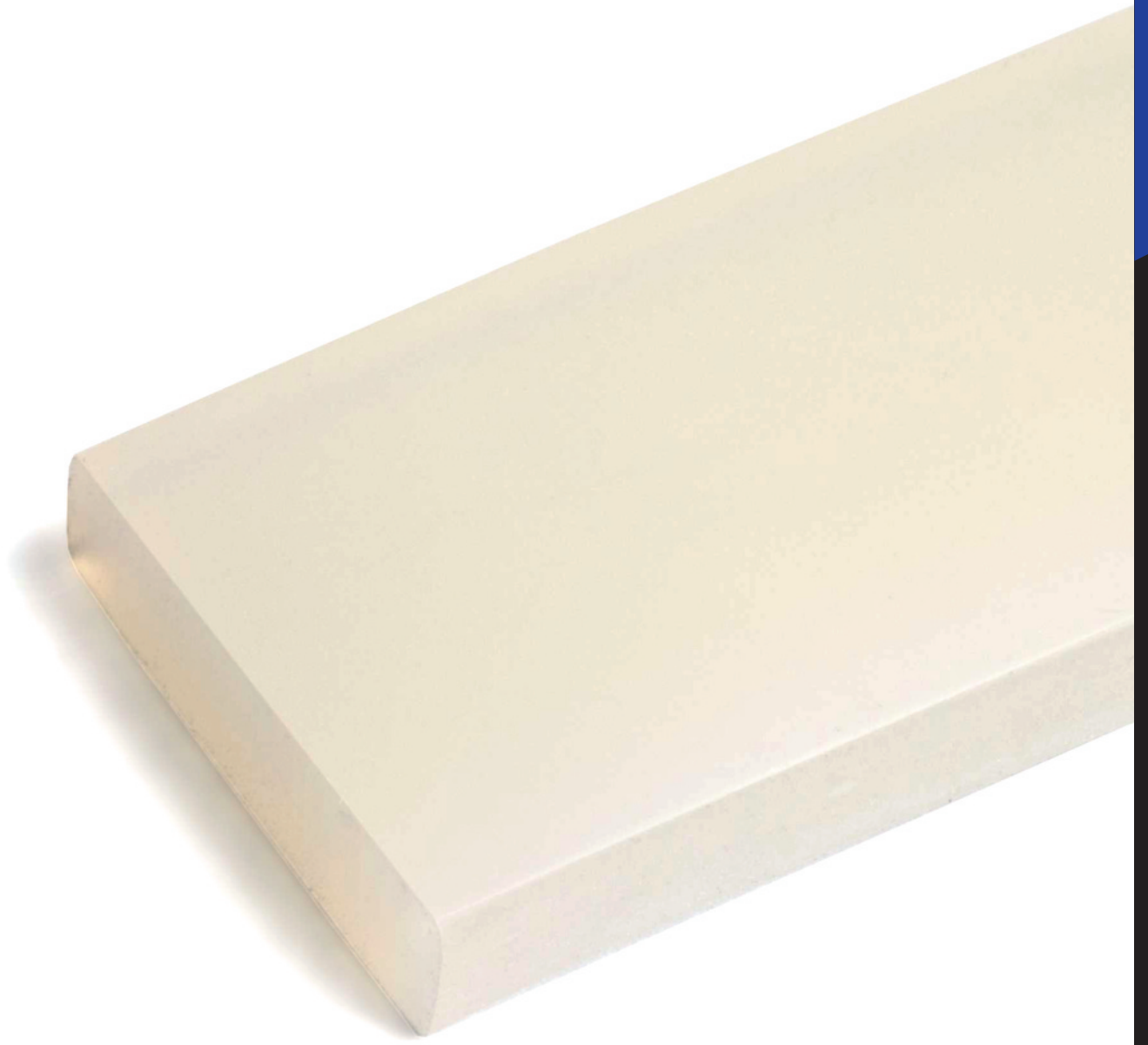

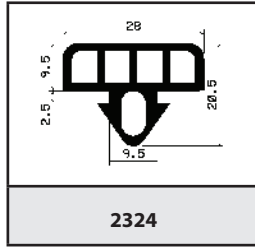
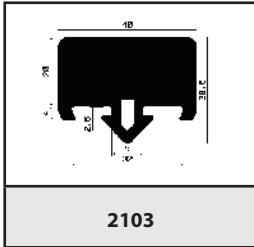
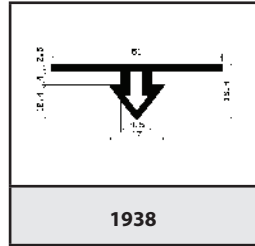
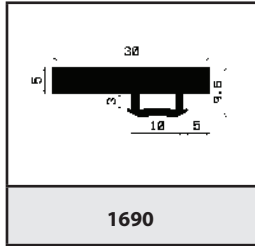
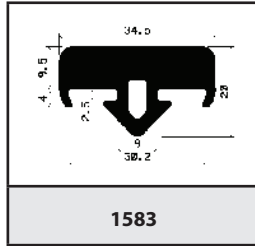
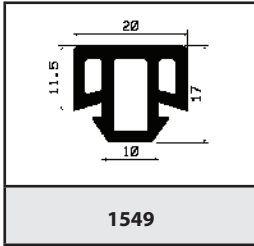
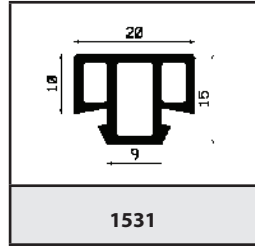
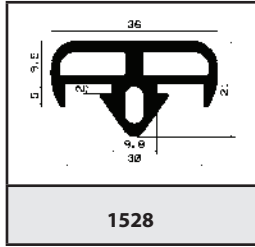
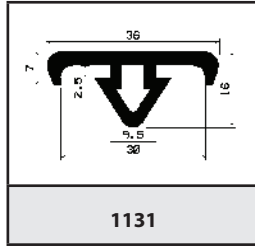
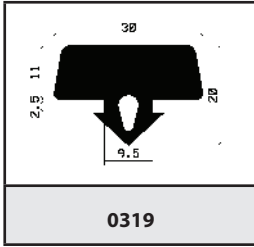
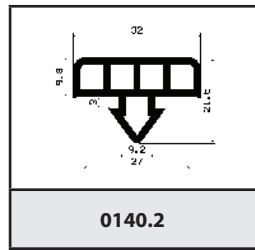
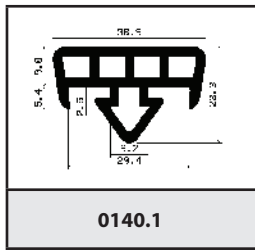
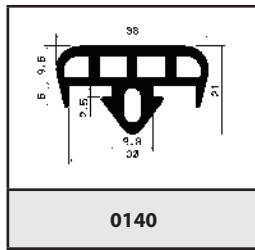
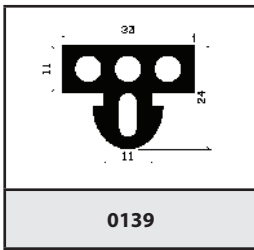

○ foam, foam / silicone

● rubber, silicone

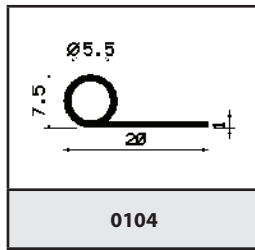

0104

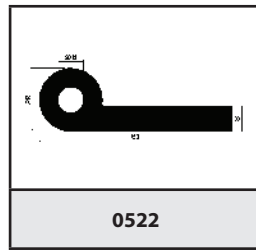

0522

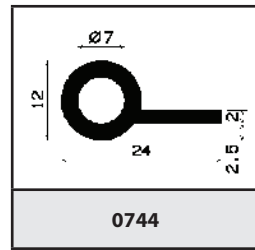

0744

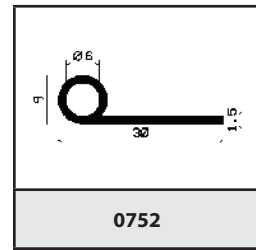

0752

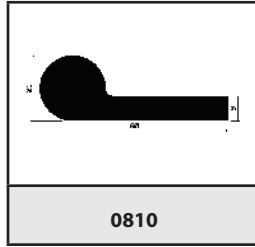

0810

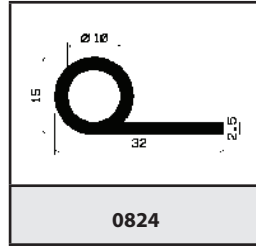

0824

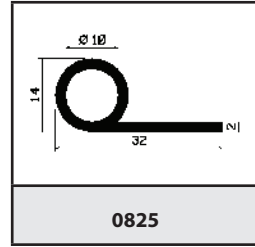

0825

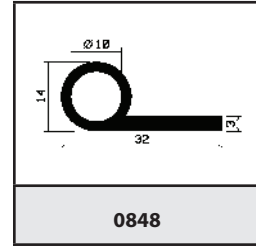

0848

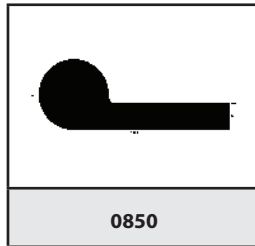

0850

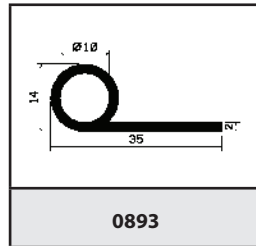

0893

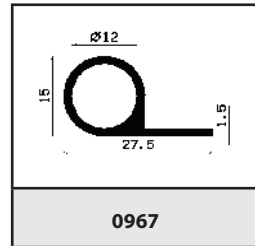

0967

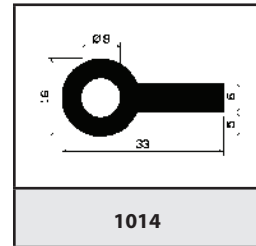

1014

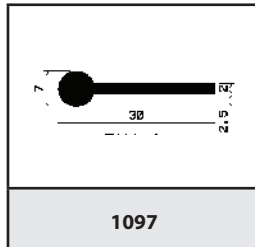

1097

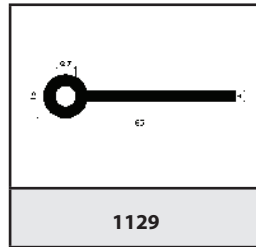

1129

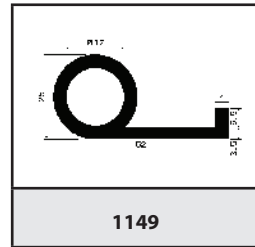

1149

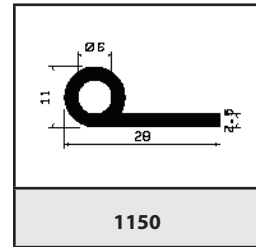

1150

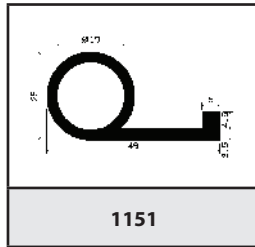

1151

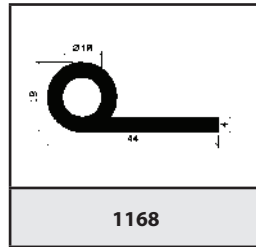

1168

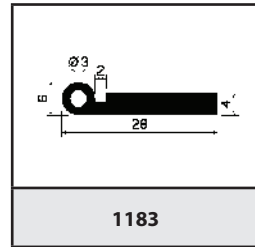

1183

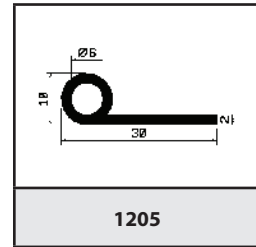

1205

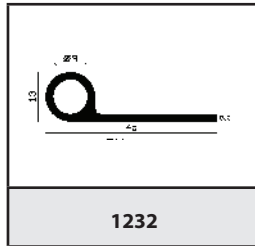

1232

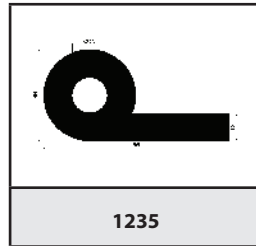

1235

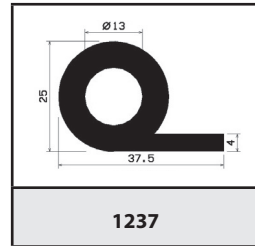

1237

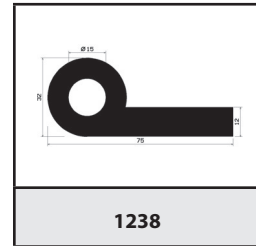

1238

○ foam, foam / silicone

● rubber, silicone

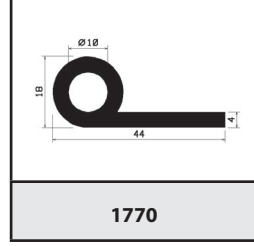
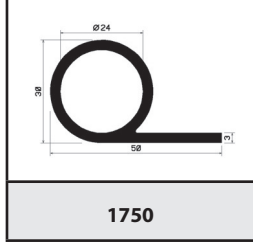
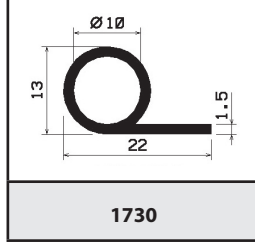
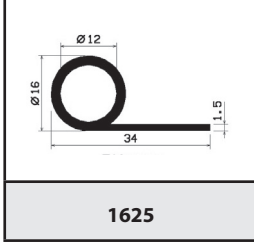
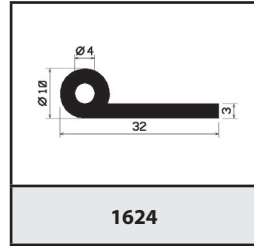
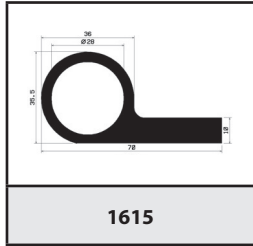
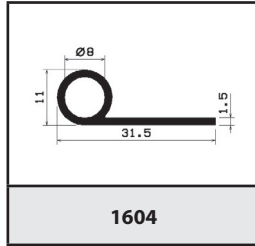
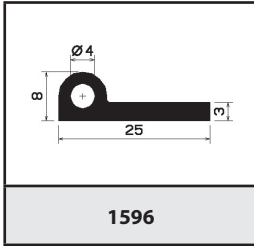
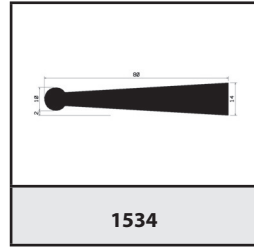
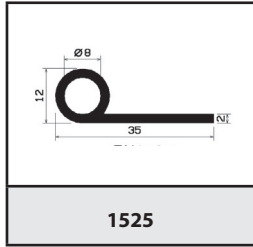
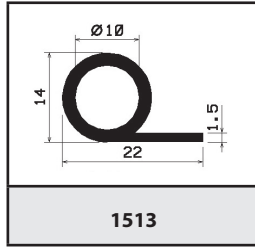
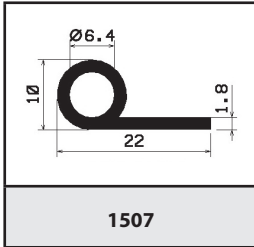
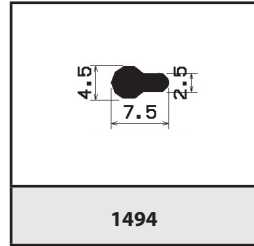
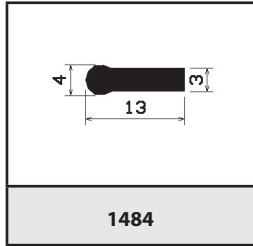
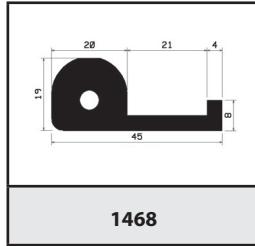
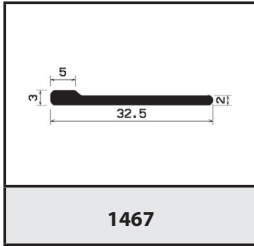
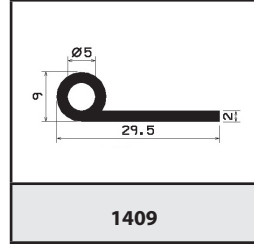
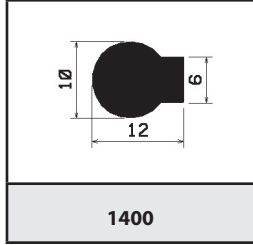
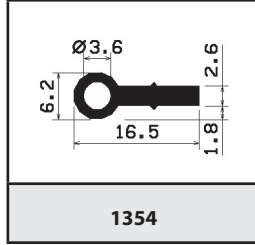
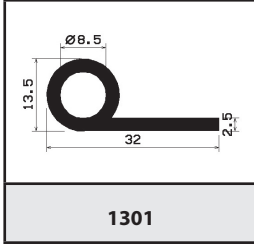
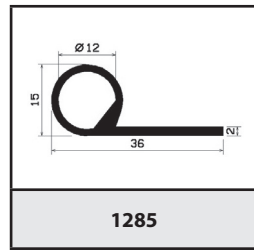
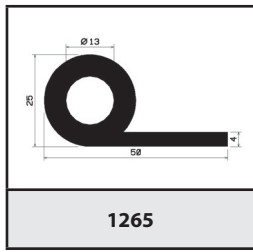
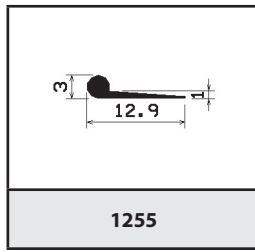
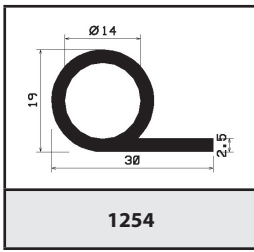

○ foam, foam / silicone

● rubber, silicone

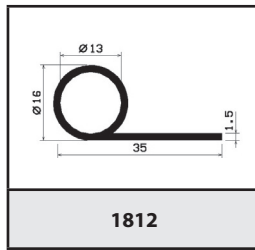

1812

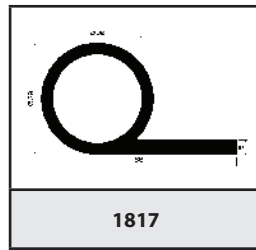

1817

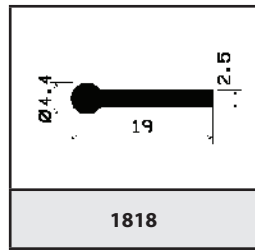

1818

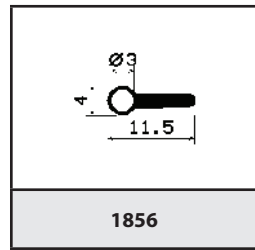

1856

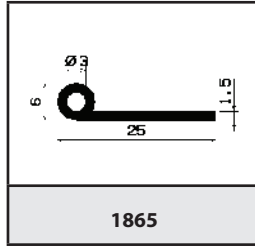

1865

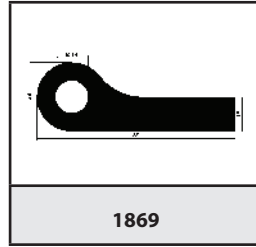

1869

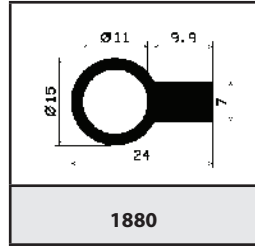

1880

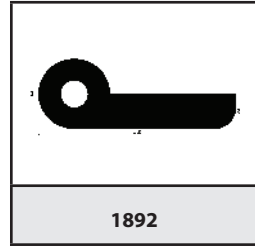

1892

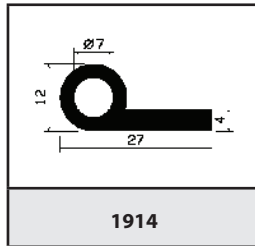

1914

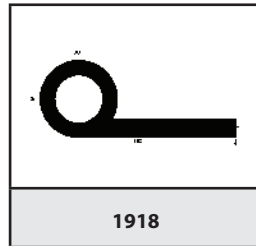

1918

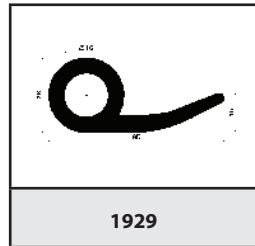

1929

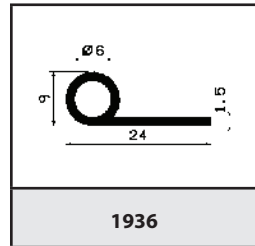

1936

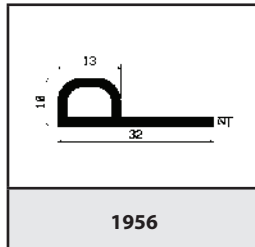

1956

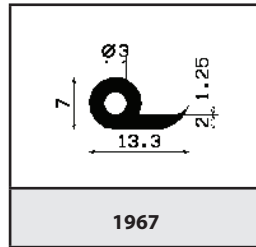

1967

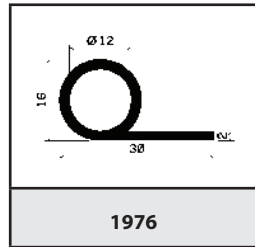

1976

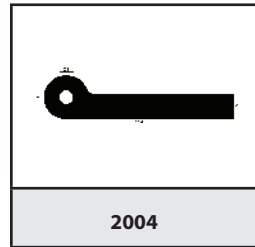

2004

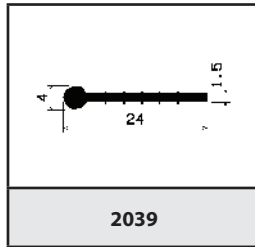

2039

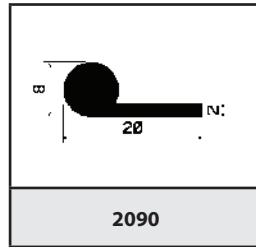

2090

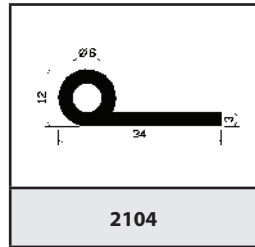

2104

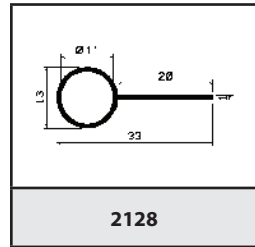

2128

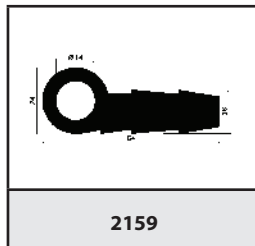

2159

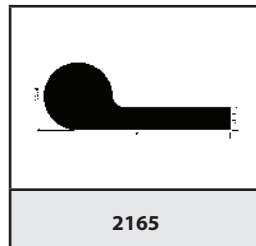

2165

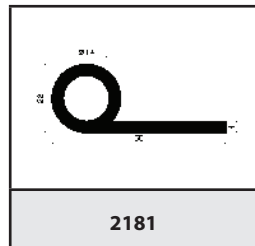

2181

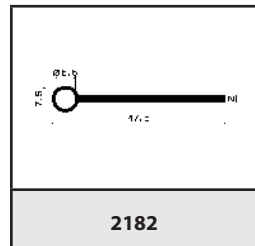

2182

○ foam, foam / silicone

● rubber, silicone

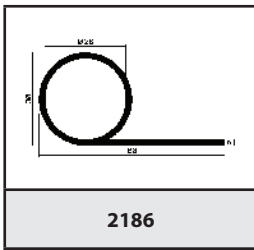

2186

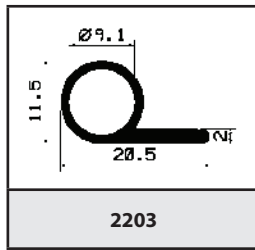

2203

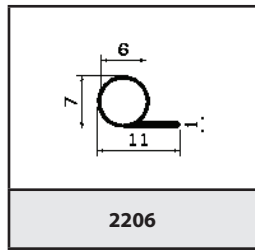

2206

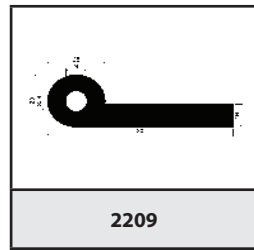

2209

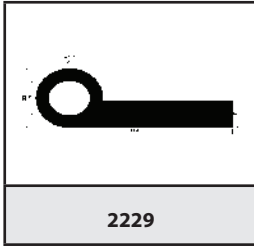

2229

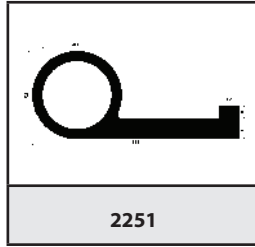

2251

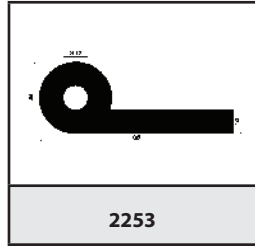

2253

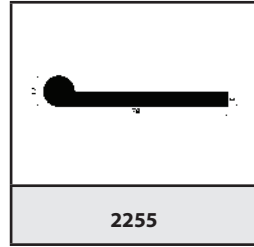

2255

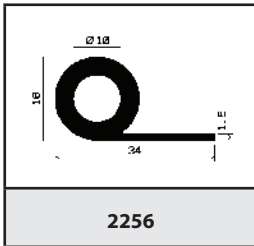

2256

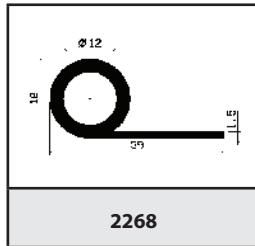

2268

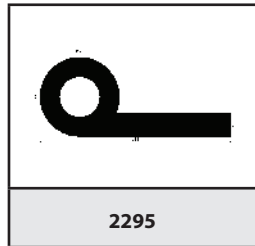

2295

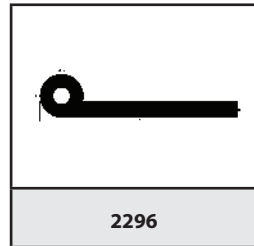

2296

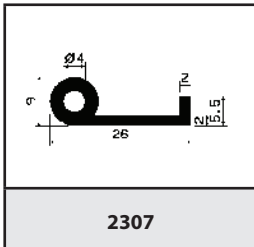

2307

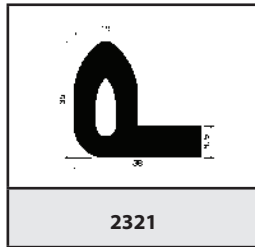

2321

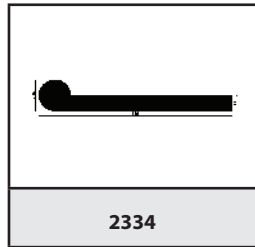

2334

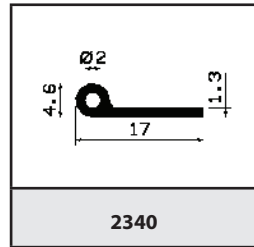

2340

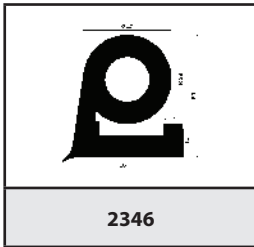

2346

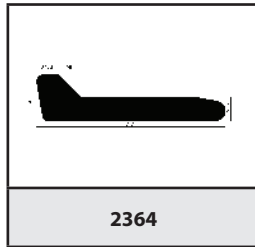

2364

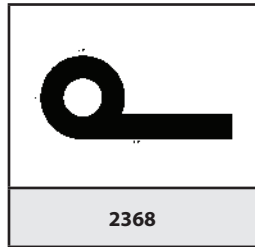

2368

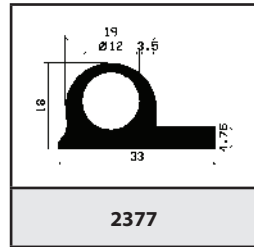

2377

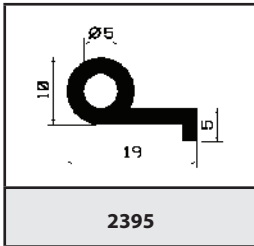

2395

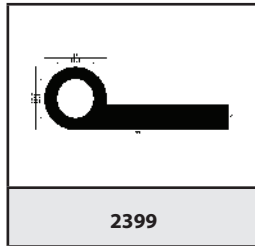

2399

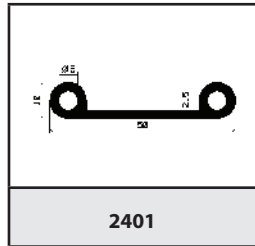

2401

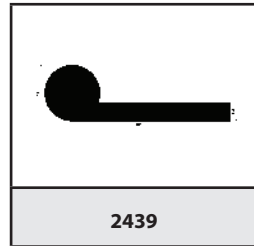

2439

○ foam, foam / silicone

● rubber, silicone

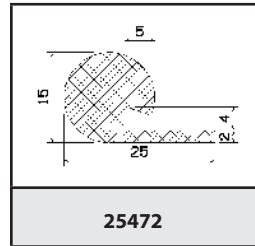
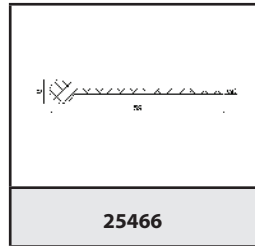
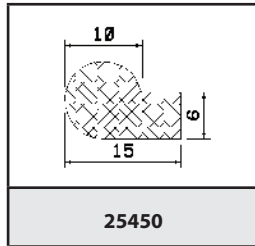
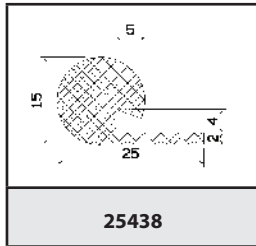
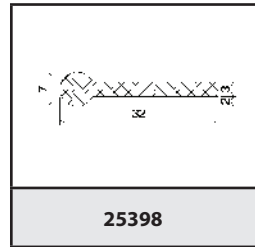
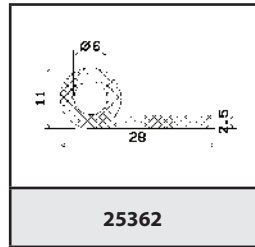
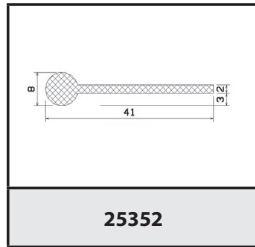
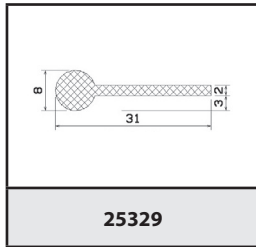
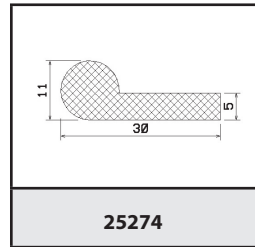
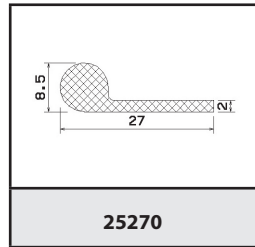
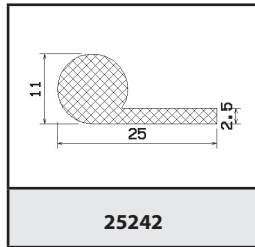
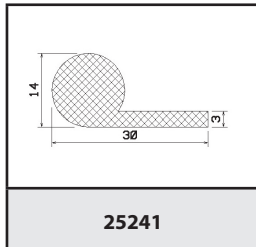
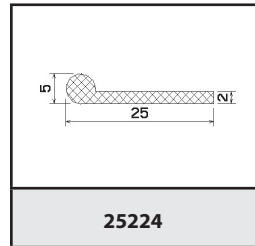
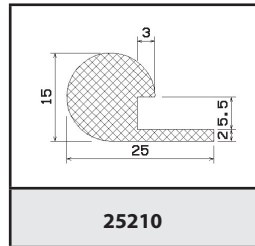
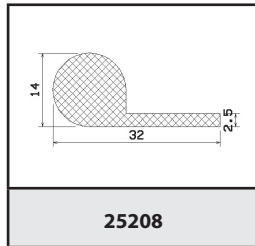
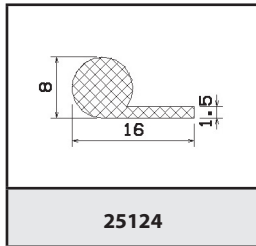
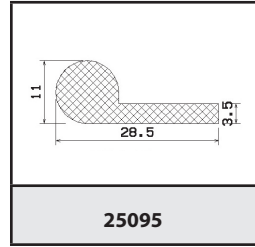
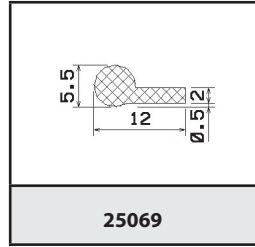
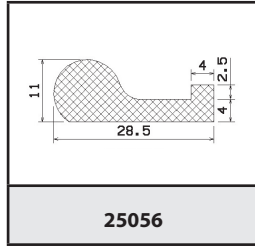
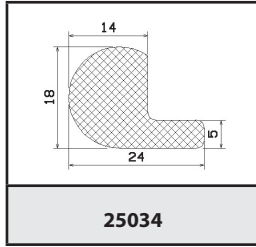
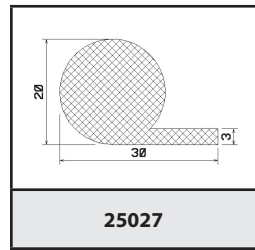
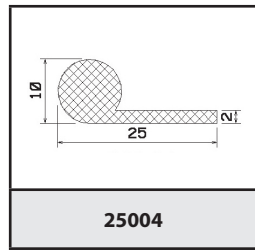
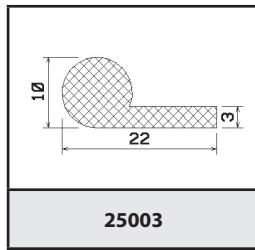
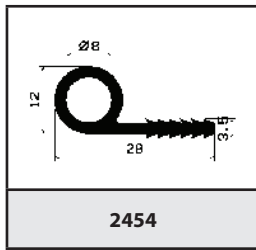

○ foam, foam / silicone

● rubber, silicone

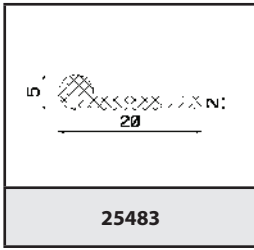

25483

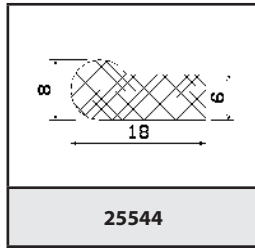

25544

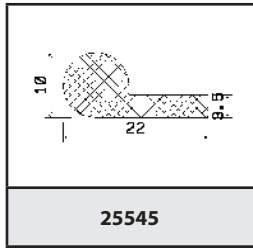

25545

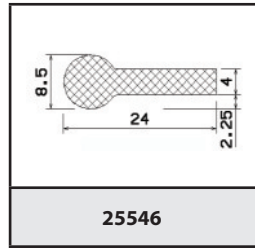

25546

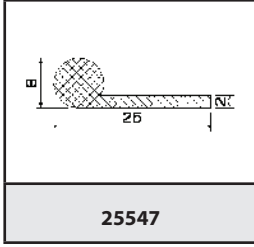

25547

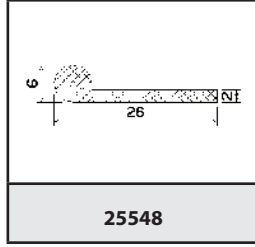

25548

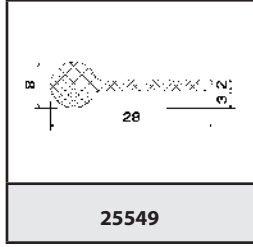

25549

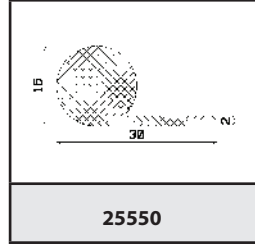

25550

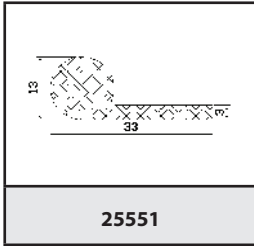

25551

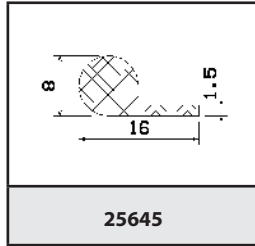

25645

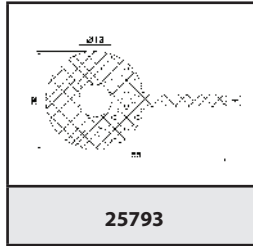

25793

○ foam, foam / silicone

● rubber, silicone

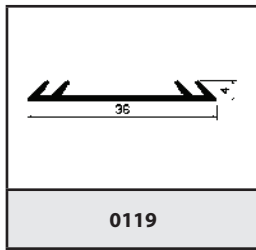

0119

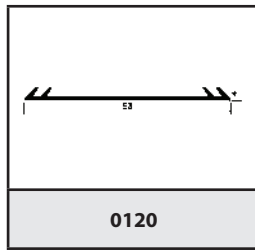

0120

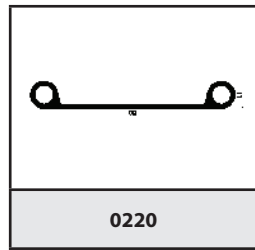

0220

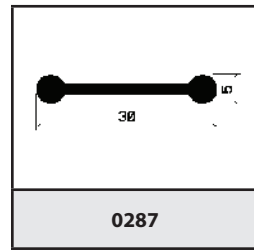

0287

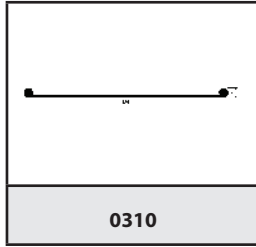

0310

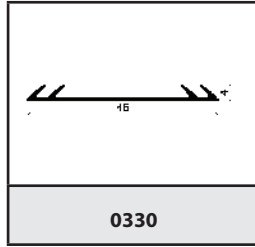

0330

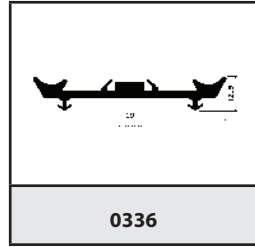

0336

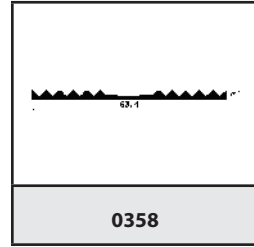

0358

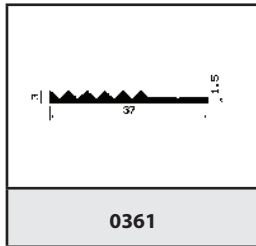

0361

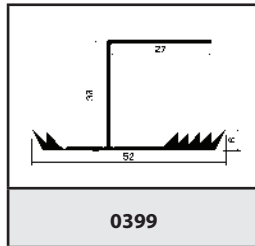

0399

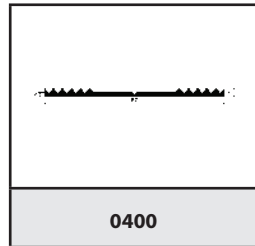

0400

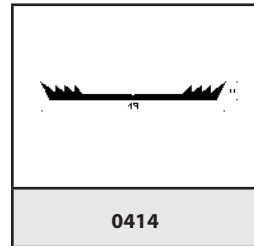

0414

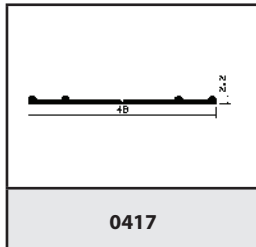

0417

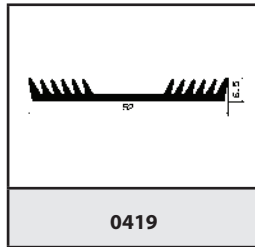

0419

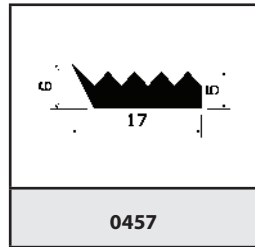

0457

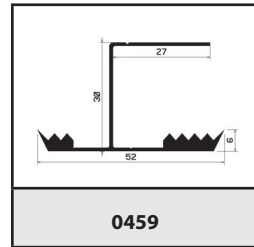

0459

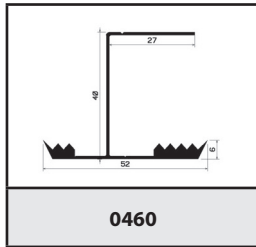

0460

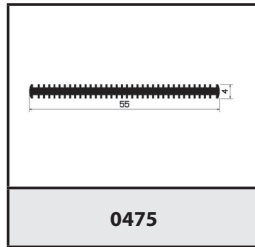

0475

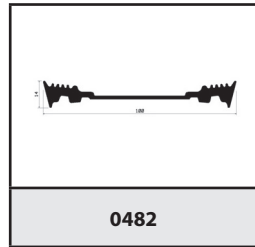

0482

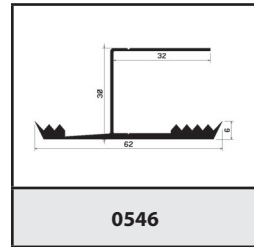

0546

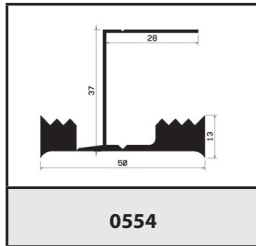

0554

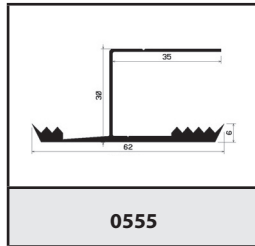

0555

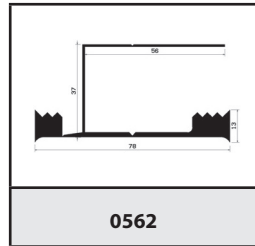

0562

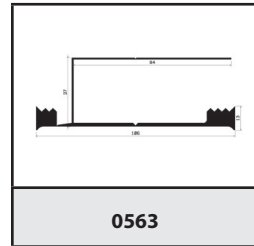

0563

○ foam, foam / silicone

● rubber, silicone

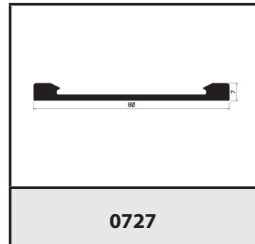
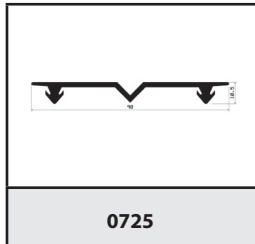
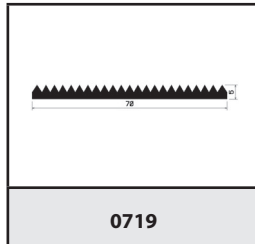
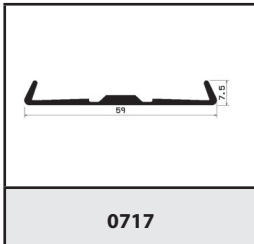
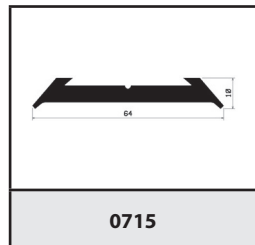
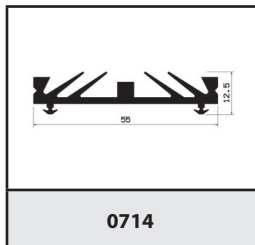
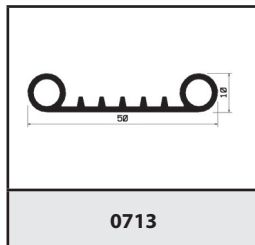
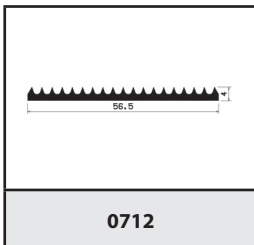
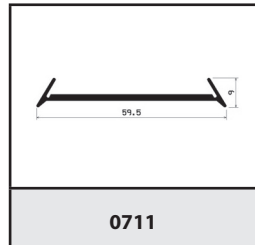
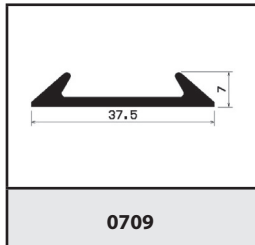
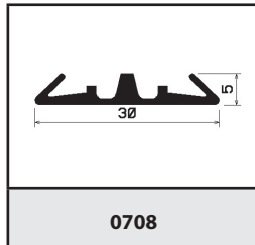
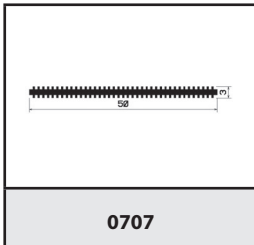
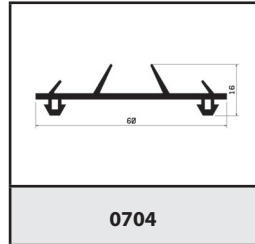
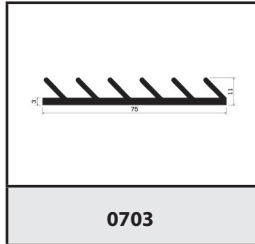
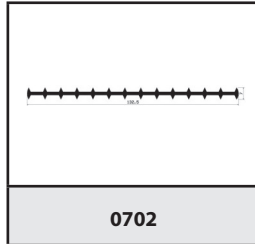
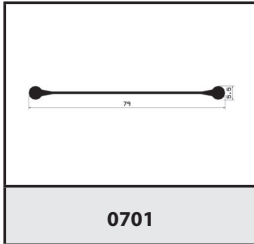
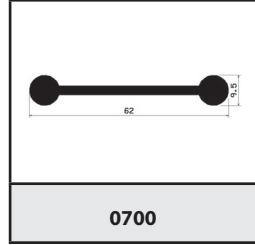
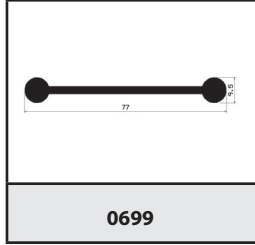
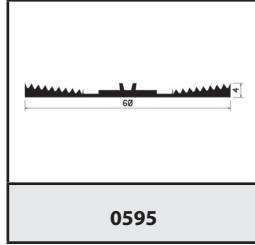
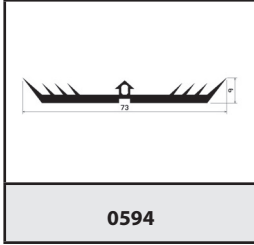
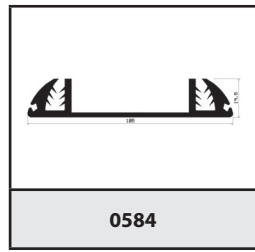
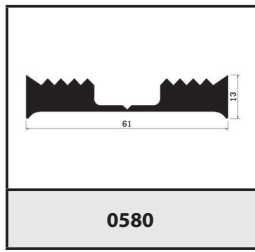
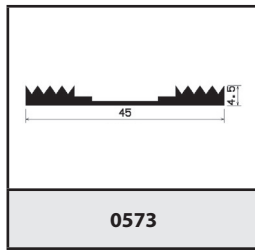
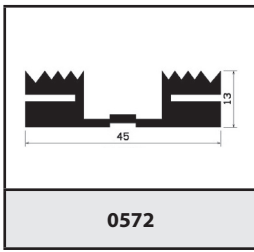

○ foam, foam / silicone

● rubber, silicone

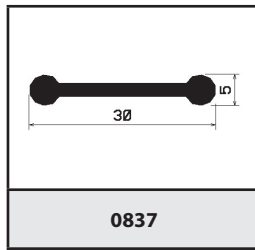

0837

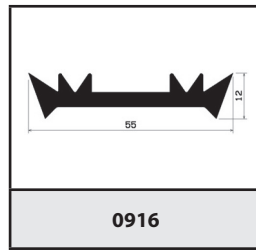

0916

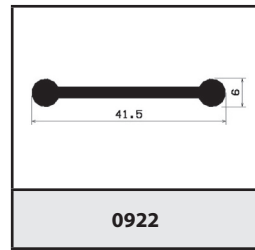

0922

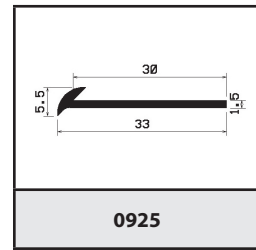

0925

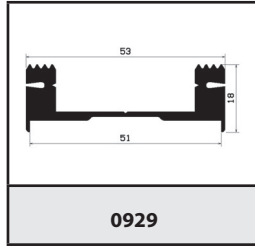

0929

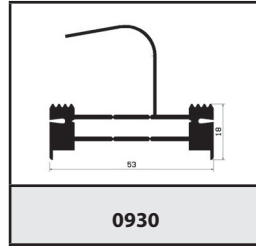

0930

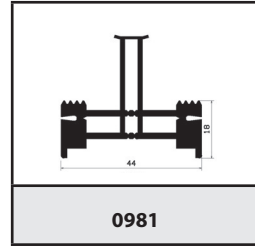

0981

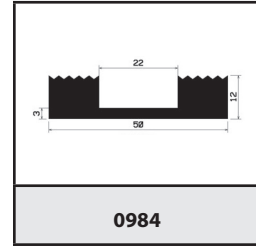

0984

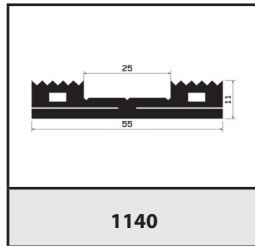

1140

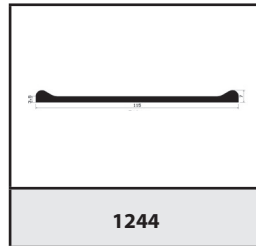

1244

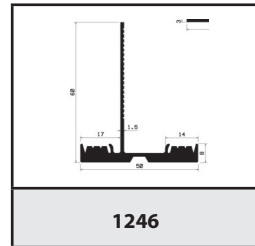

1246

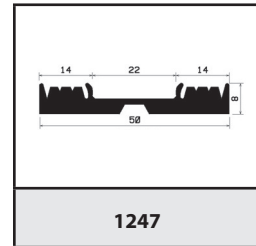

1247

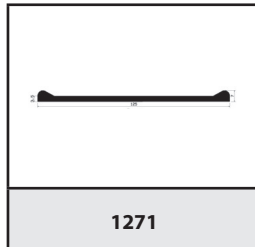

1271

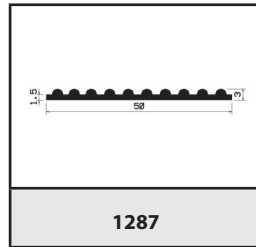

1287

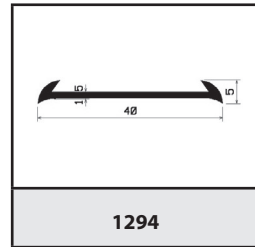

1294

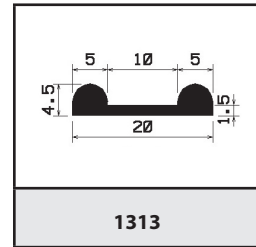

1313

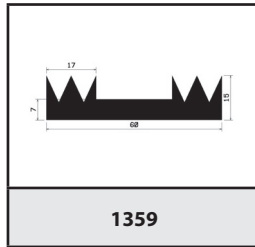

1359

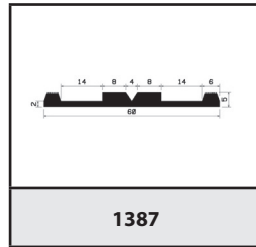

1387

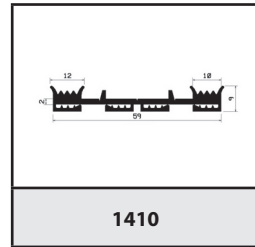

1410

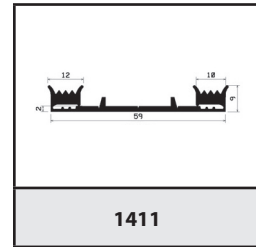

1411

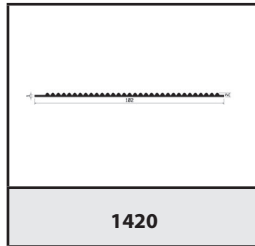

1420

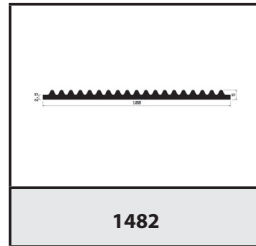

1482

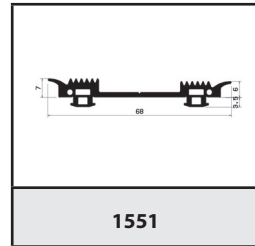

1551

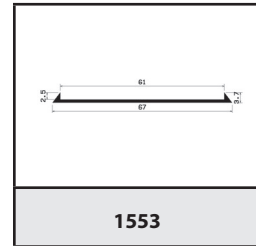

1553

○ foam, foam / silicone

● rubber, silicone

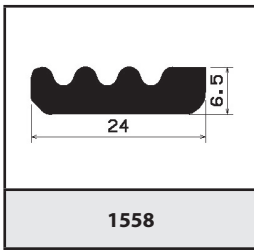

1558

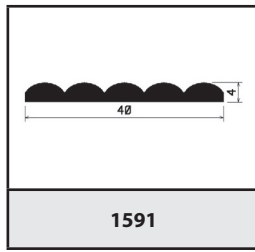

1591

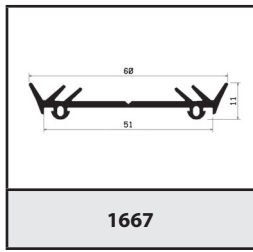

1667

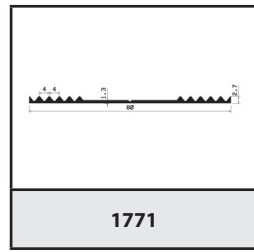

1771

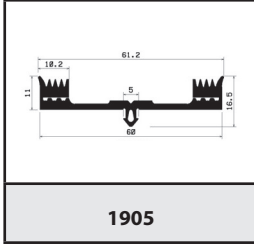

1905

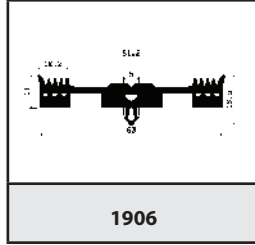

1906

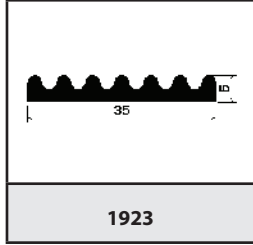

1923

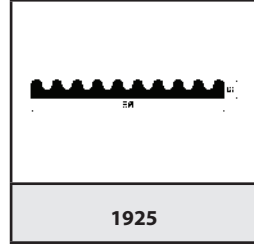

1925

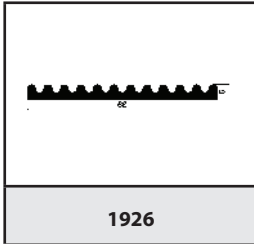

1926

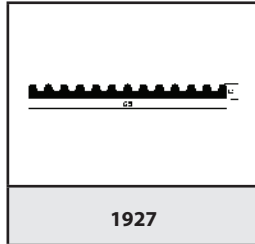

1927

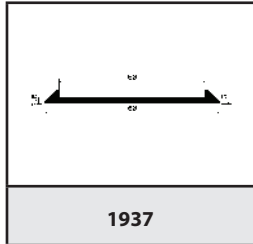

1937

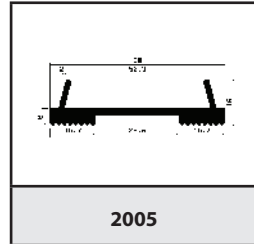

2005

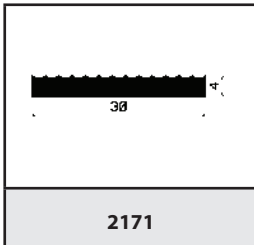

2171

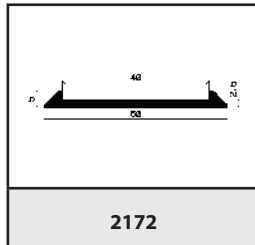

2172

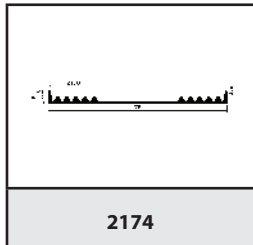

2174

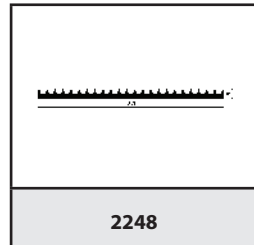

2248

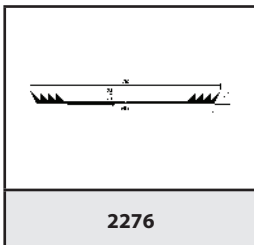

2276

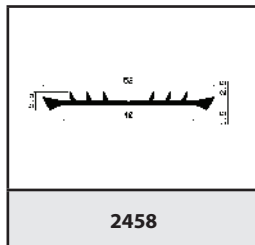

2458

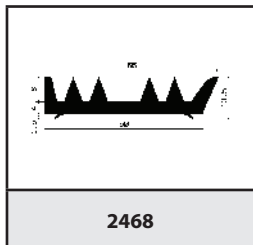

2468

○ foam, foam / silicone

● rubber, silicone

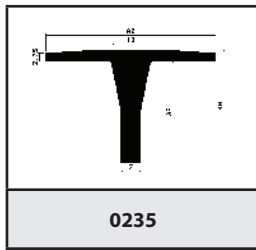

0235

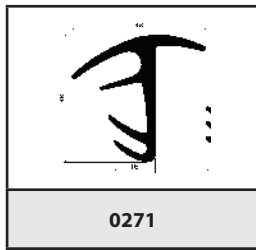

0271

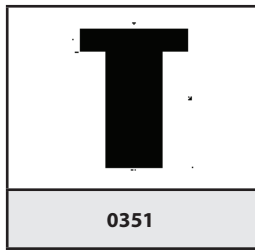

0351

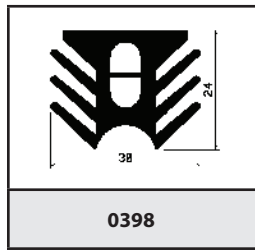

0398

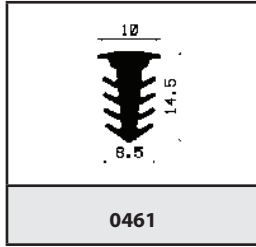

0461

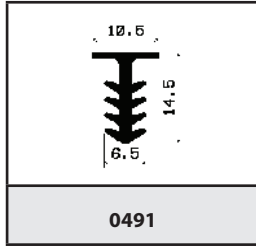

0491

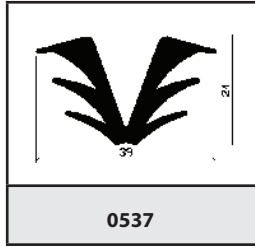

0537

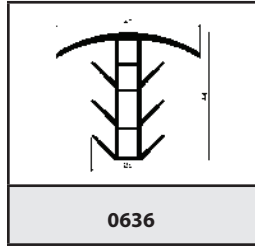

0636

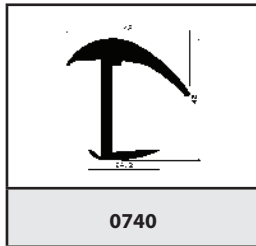

0740

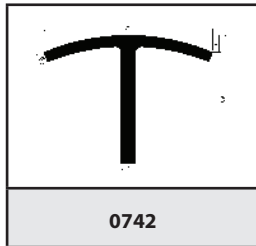

0742

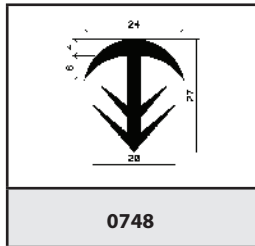

0748

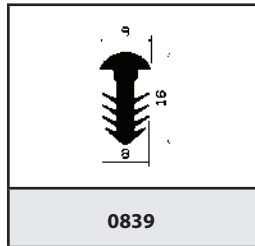

0839

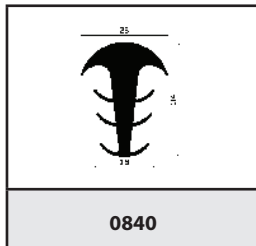

0840

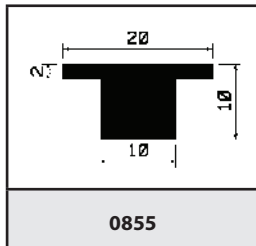

0855

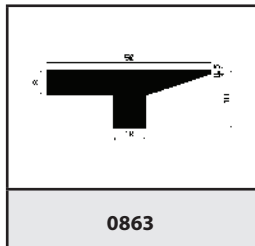

0863

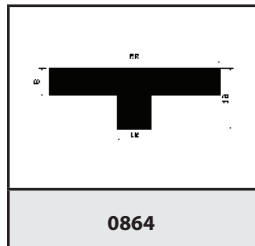

0864

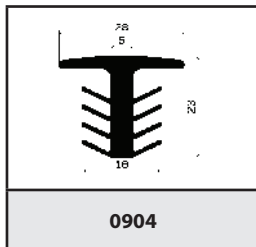

0904

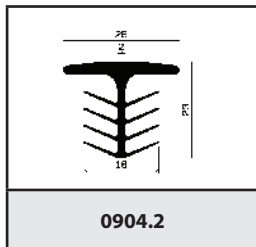

0904.2

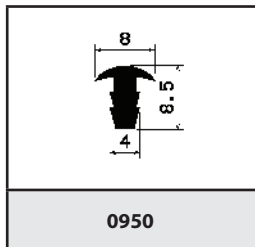

0950

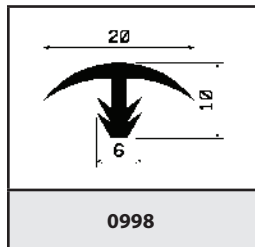

0998

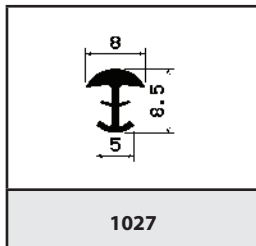

1027

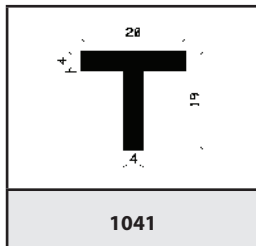

1041

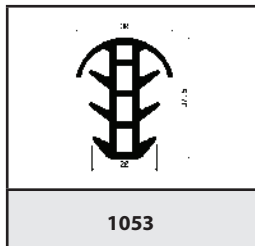

1053

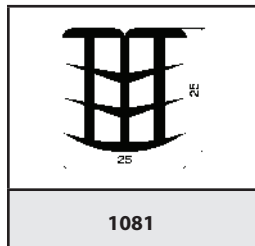

1081

○ foam, foam / silicone

● rubber, silicone

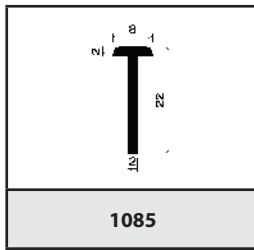

1085

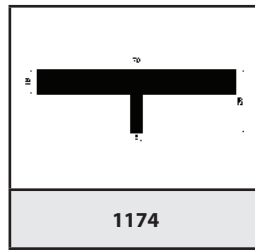

1174

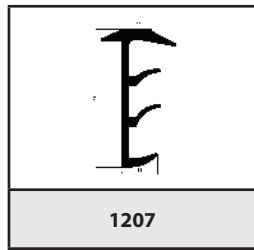

1207

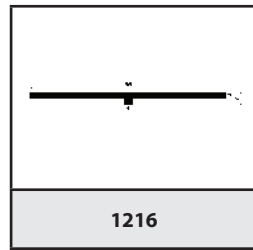

1216

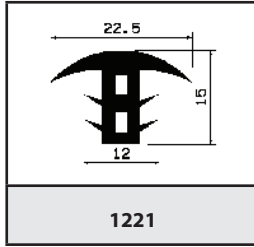

1221

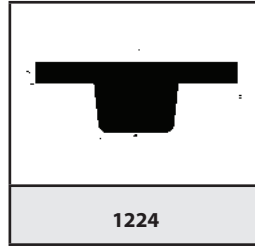

1224

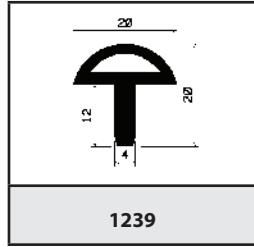

1239

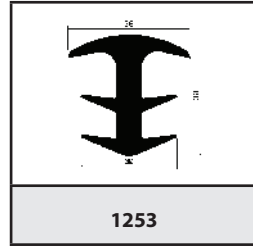

1253

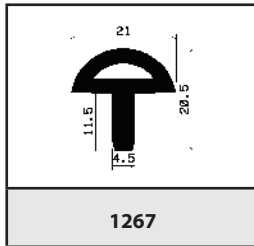

1267

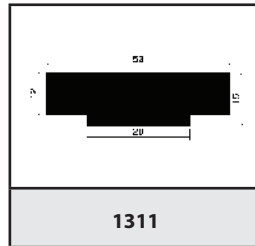

1311

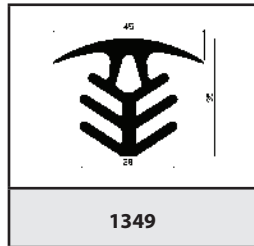

1349

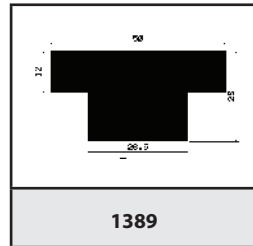

1389

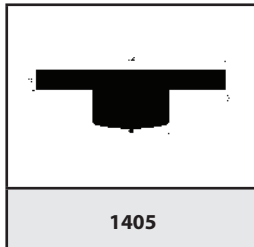

1405

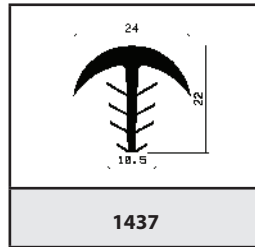

1437

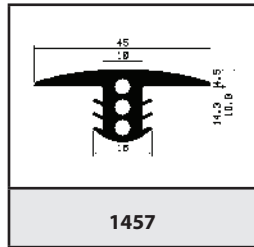

1457

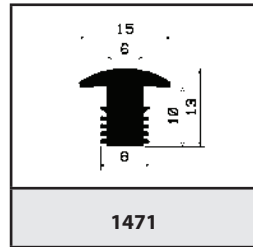

1471

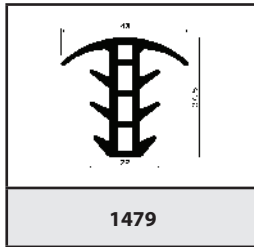

1479

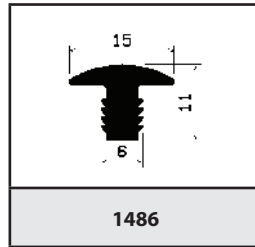

1486

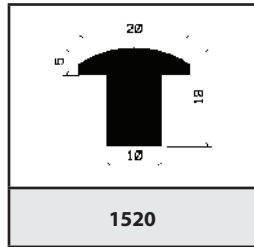

1520

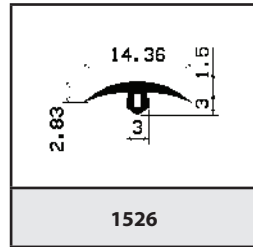

1526

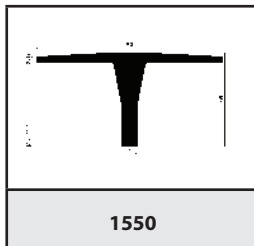

1550

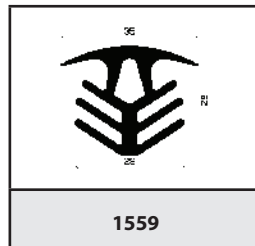

1559

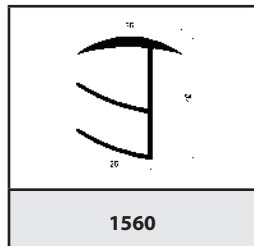

1560

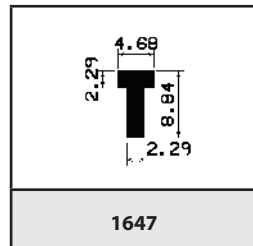

1647

○ foam, foam / silicone

● rubber, silicone

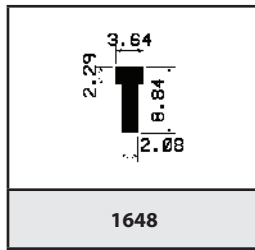

1648

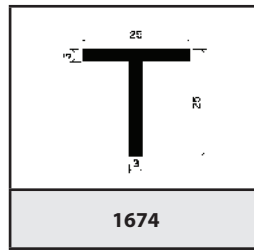

1674

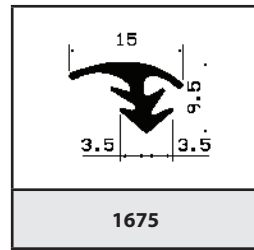

1675

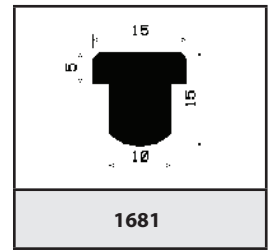

1681

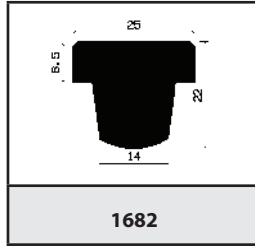

1682

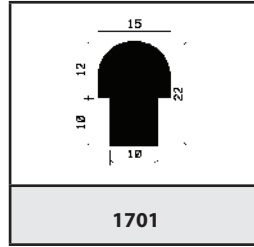

1701

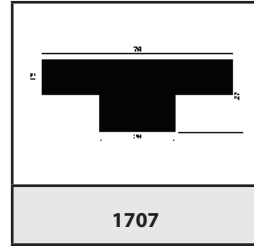

1707

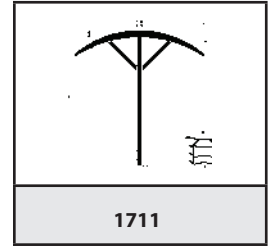

1711

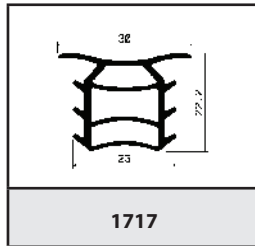

1717

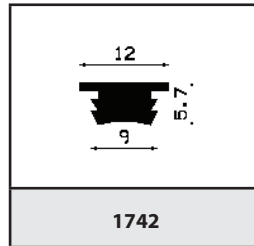

1742

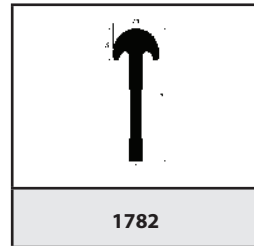

1782

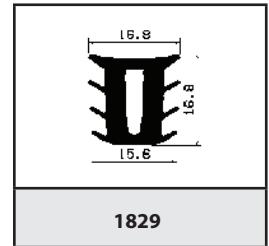

1829

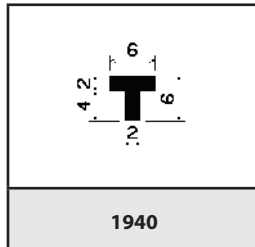

1940

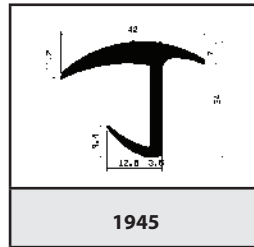

1945

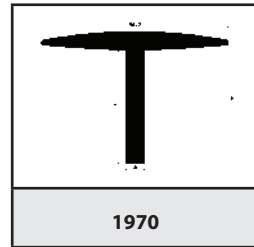

1970

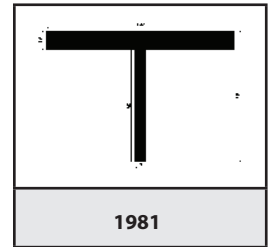

1981

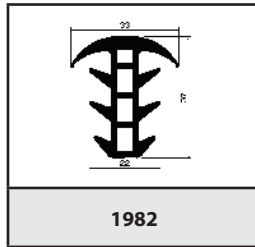

1982

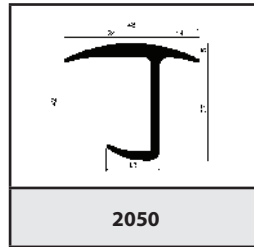

2050

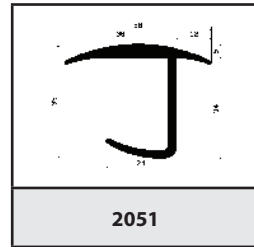

2051

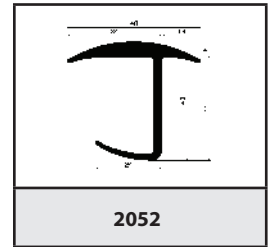

2052

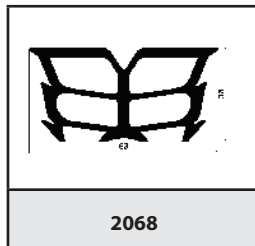

2068

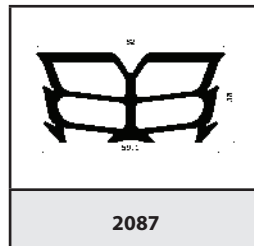

2087

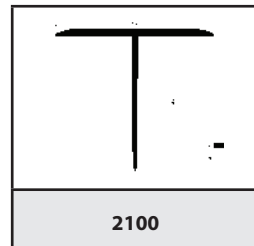

2100

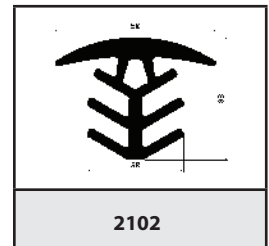

2102

○ foam, foam / silicone

● rubber, silicone

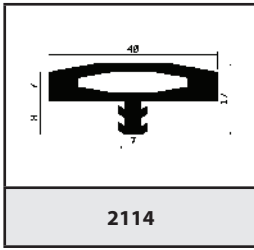

2114

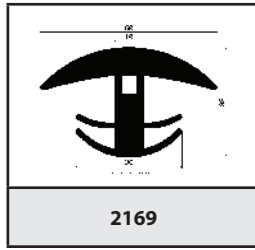

2169

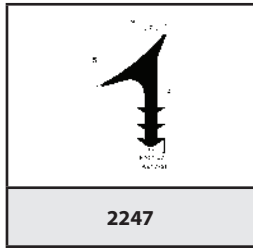

2247

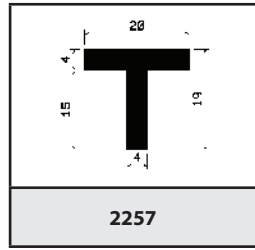

2257

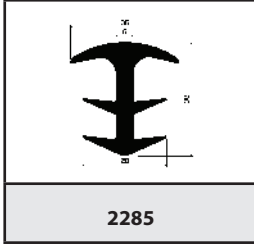

2285

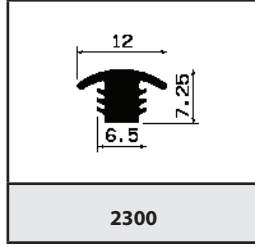

2300

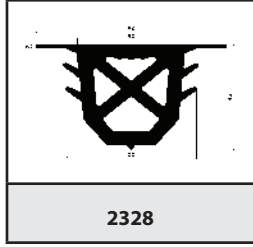

2328

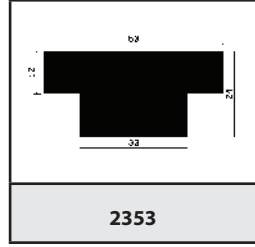

2353

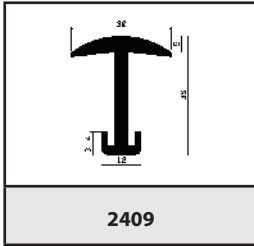

2409

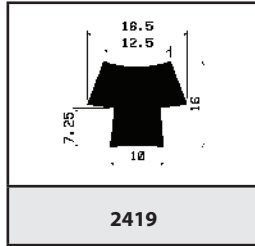

2419

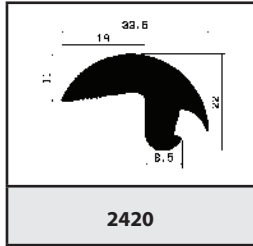

2420

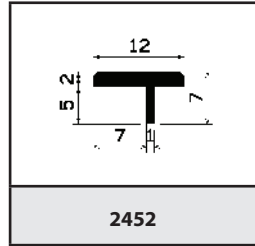

2452

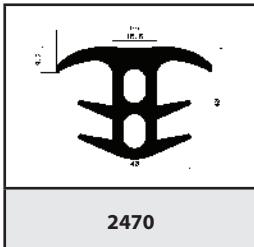

2470

○ foam, foam / silicone

● rubber, silicone

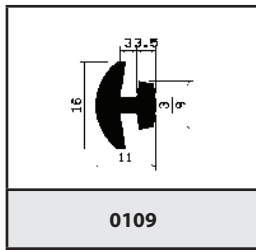

0109

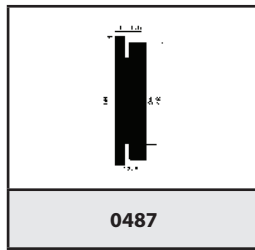

0487

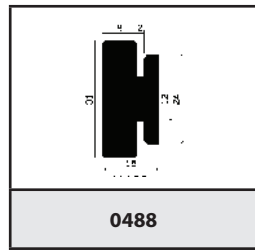

0488

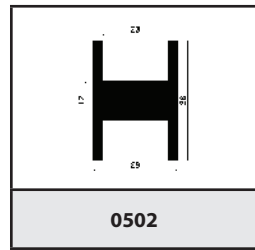

0502

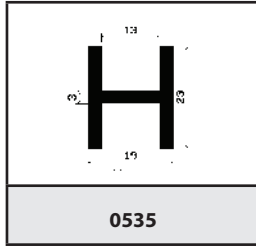

0535

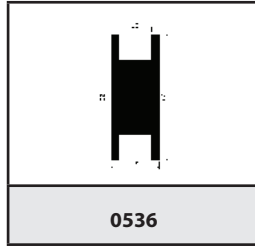

0536

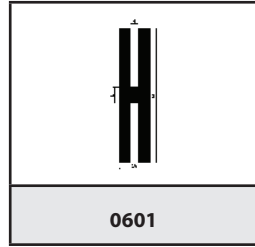

0601

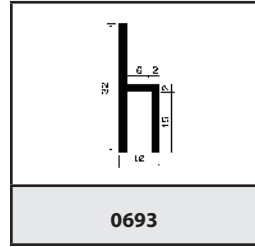

0693

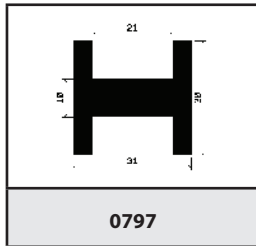

0797

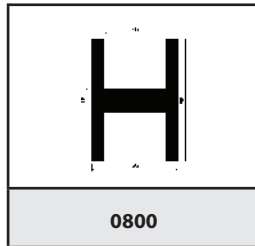

0800

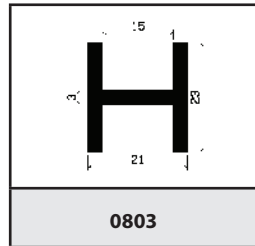

0803

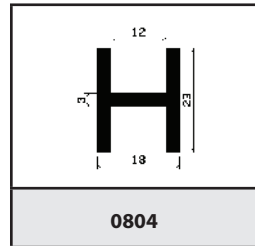

0804

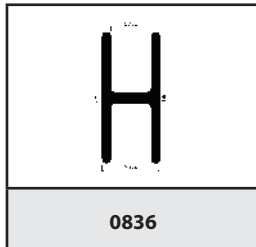

0836

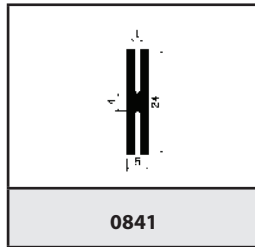

0841

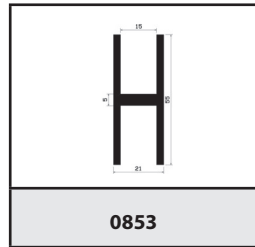

0853

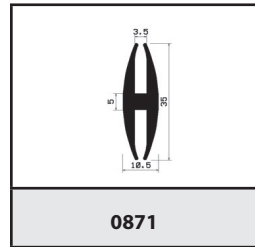

0871

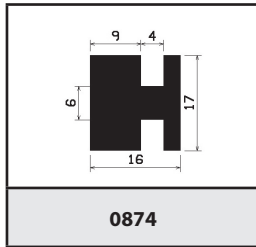

0874

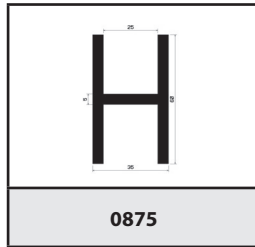

0875

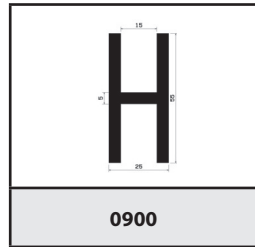

0900

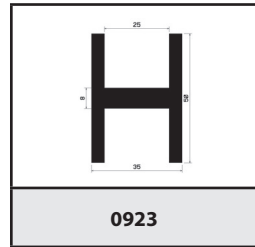

0923

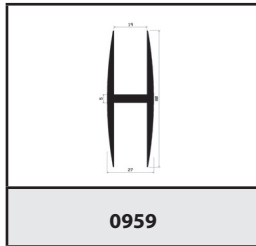

0959

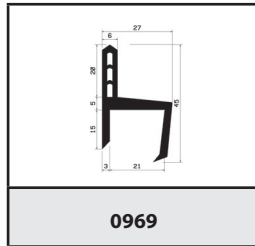

0969

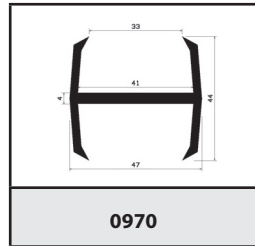

0970

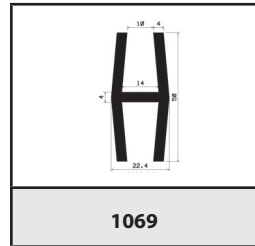

1069

○ foam, foam / silicone

● rubber, silicone

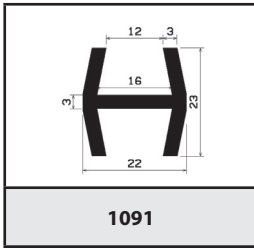

1091

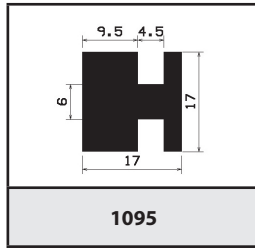

1095

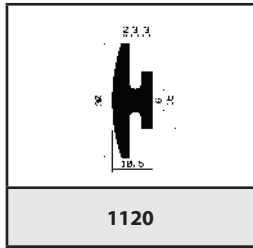

1120

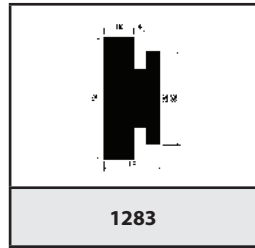

1283

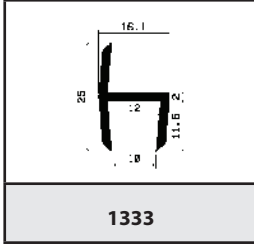

1333

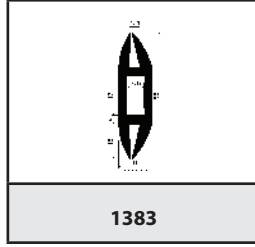

1383

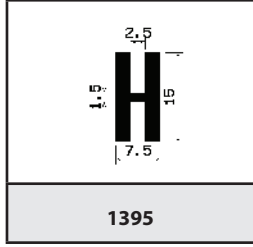

1395

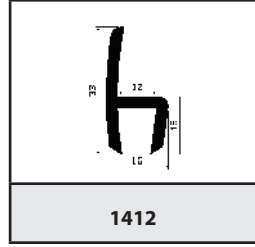

1412

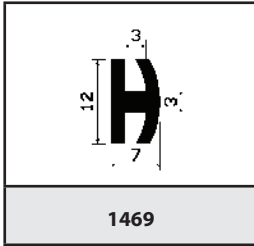

1469

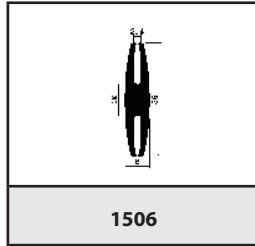

1506

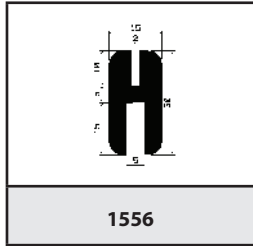

1556

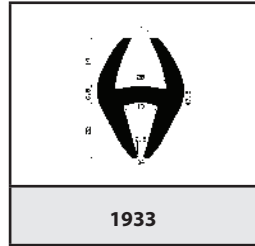

1933

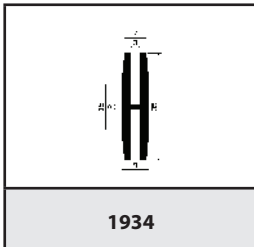

1934

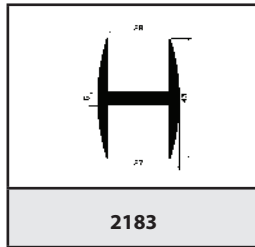

2183

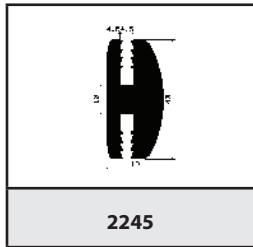

2245

○ foam, foam / silicone

● rubber, silicone

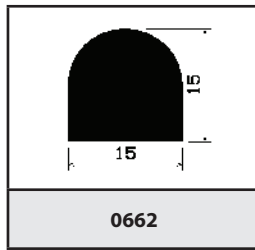

0662

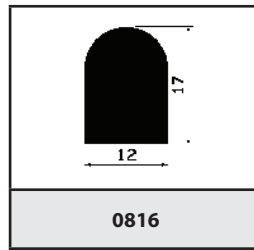

0816

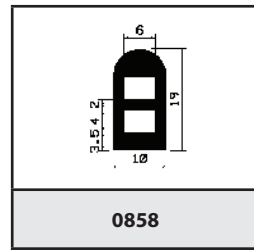

0858

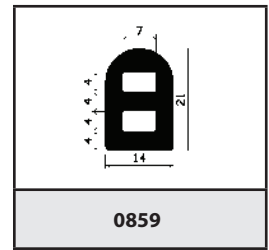

0859

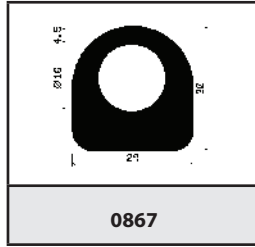

0867

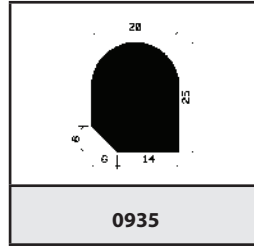

0935

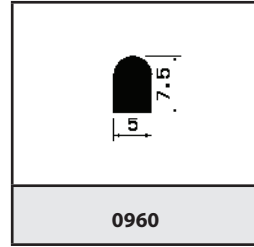

0960

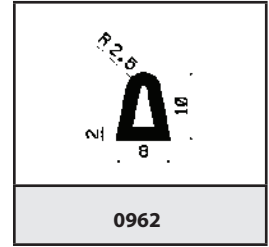

0962

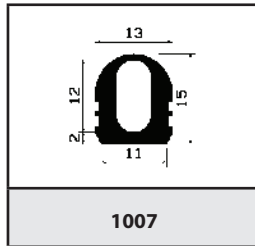

1007

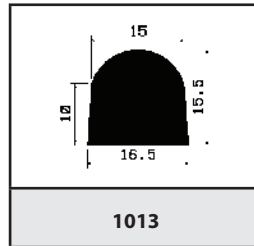

1013

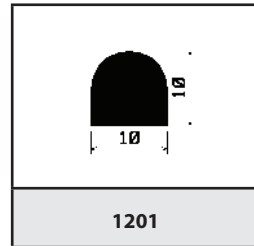

1201

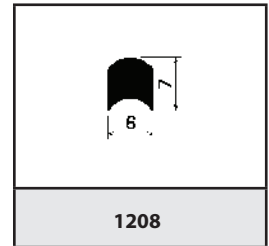

1208

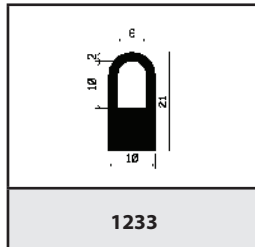

1233

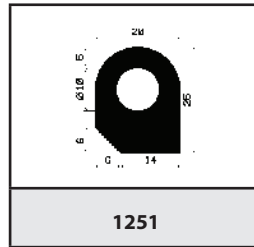

1251

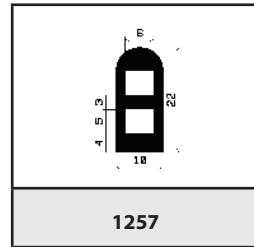

1257

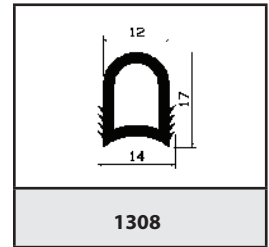

1308

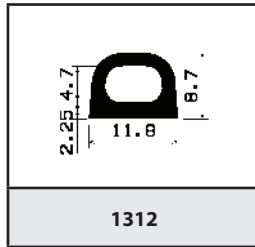

1312

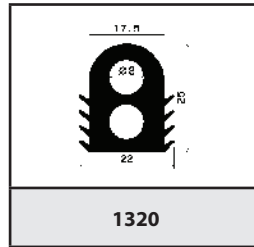

1320

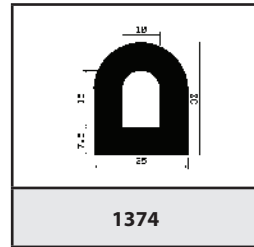

1374

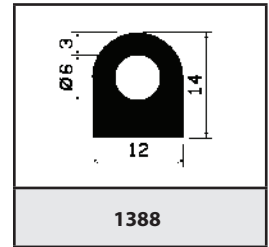

1388

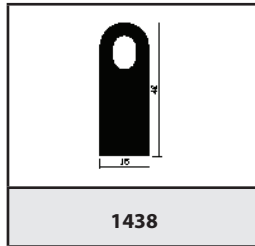

1438

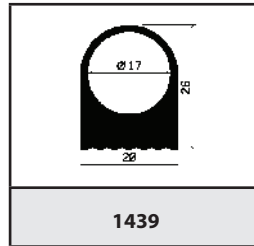

1439

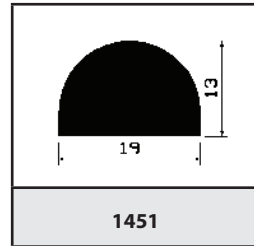

1451

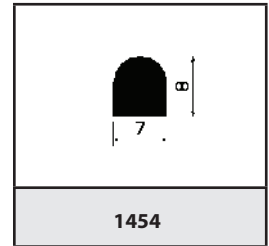

1454

○ foam, foam / silicone

● rubber, silicone

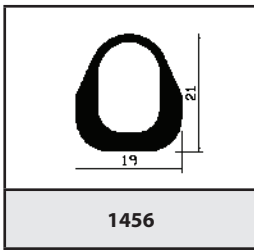

1456

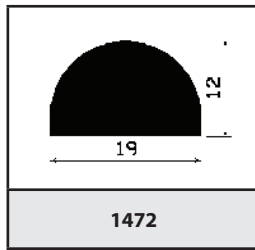

1472

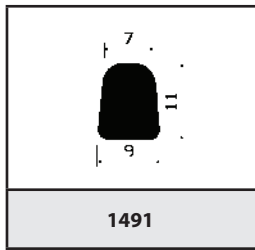

1491

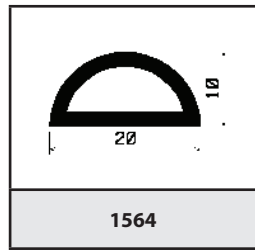

1564

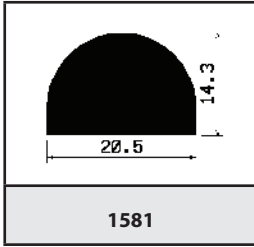

1581

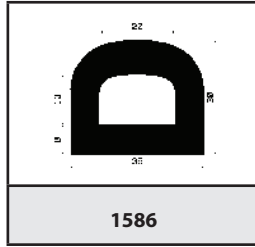

1586

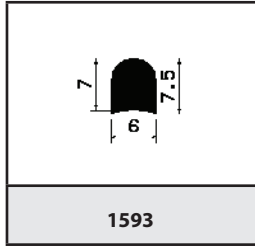

1593

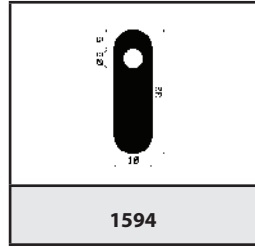

1594

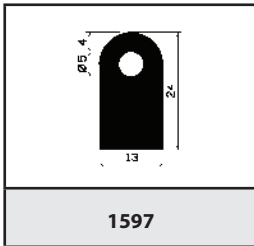

1597

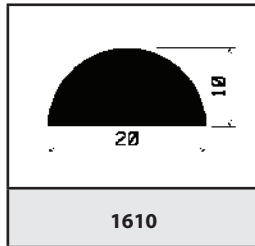

1610

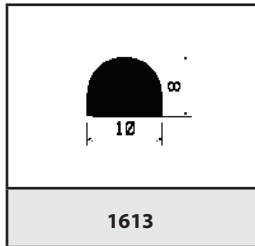

1613

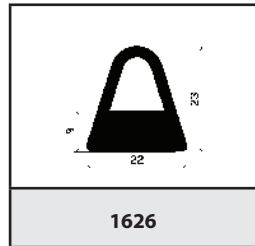

1626

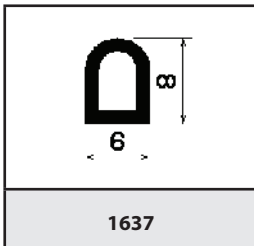

1637

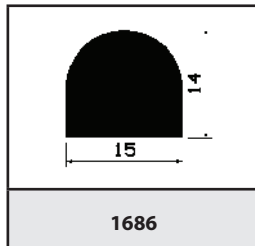

1686

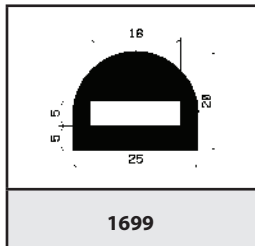

1699

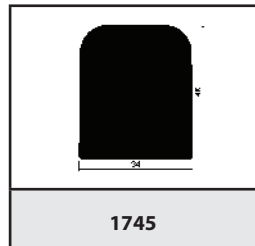

1745

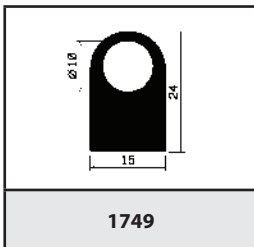

1749

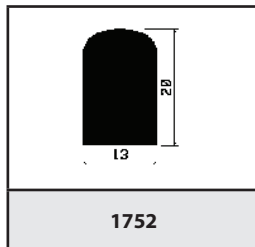

1752

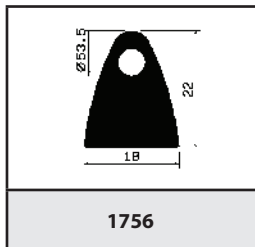

1756

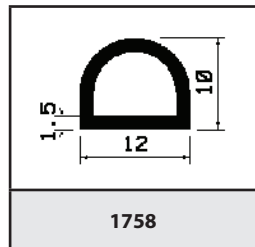

1758

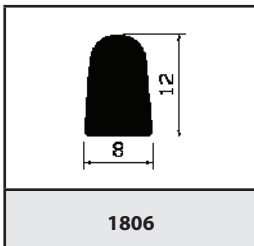

1806

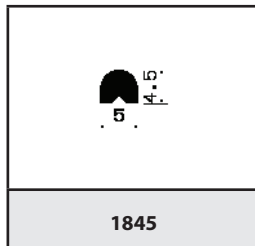

1845

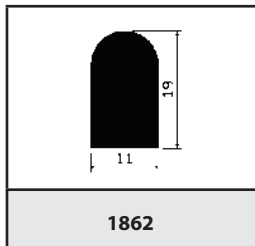

1862

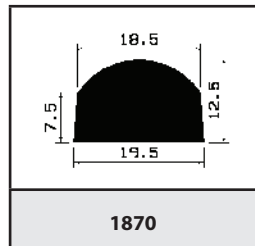

1870

○ foam, foam / silicone

● rubber, silicone

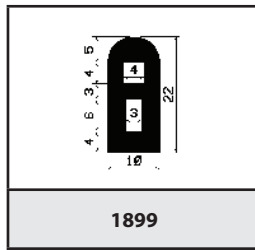

1899

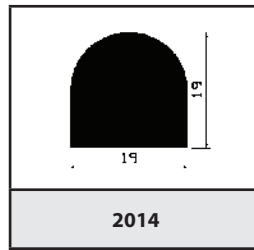

2014

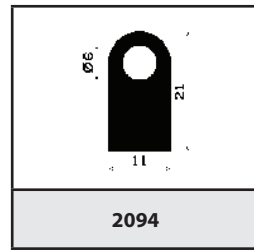

2094

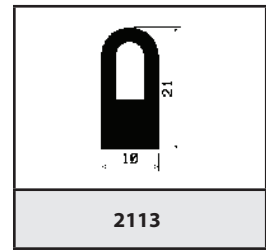

2113

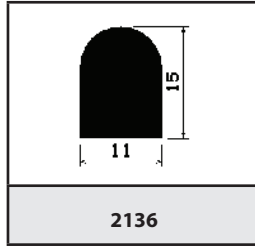

2136

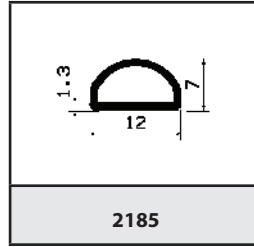

2185

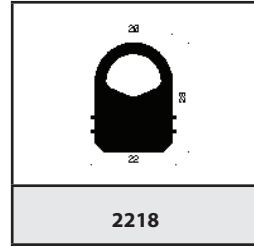

2218

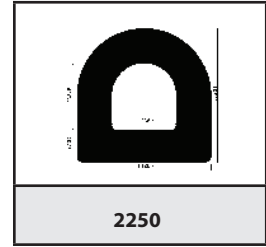

2250

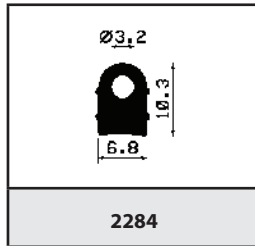

2284

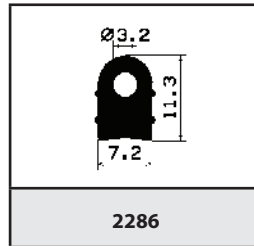

2286

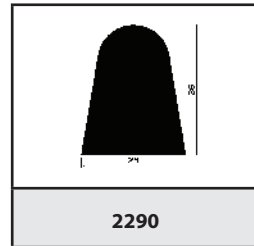

2290

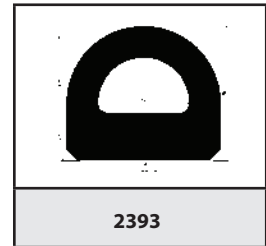

2393

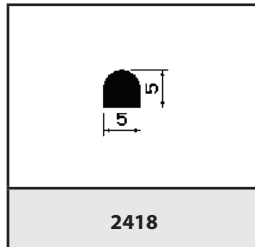

2418

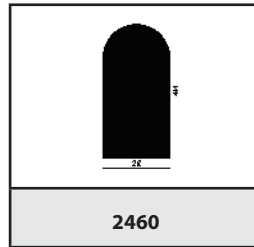

2460

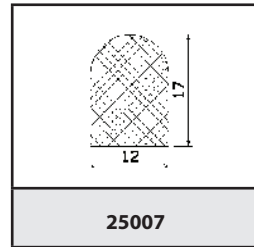

25007

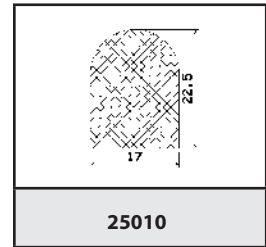

25010

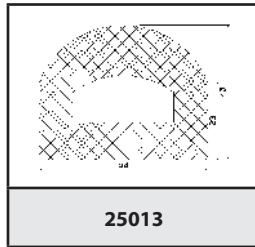

25013

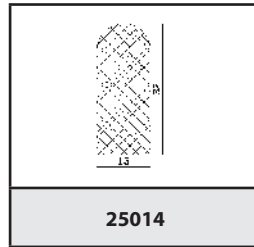

25014

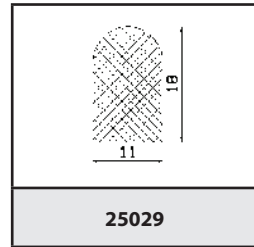

25029

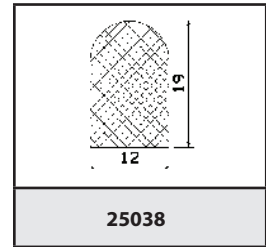

25038

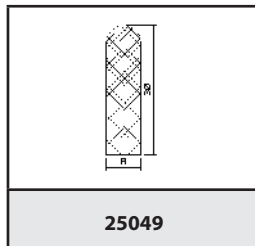

25049

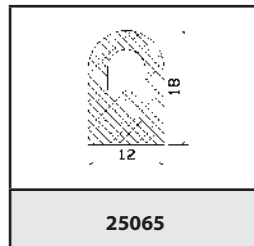

25065

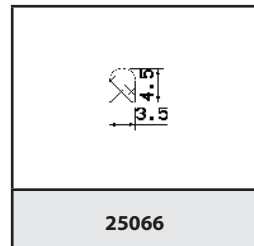

25066

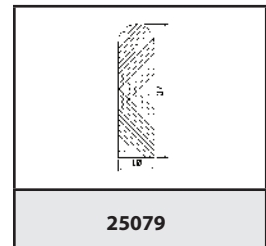

25079

○ foam, foam / silicone

● rubber, silicone

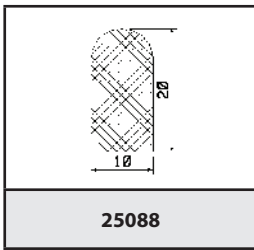

25088

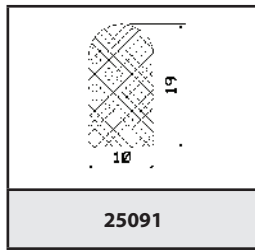

25091

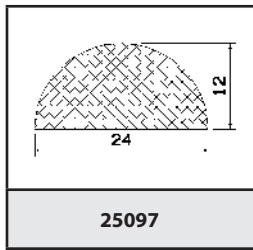

25097

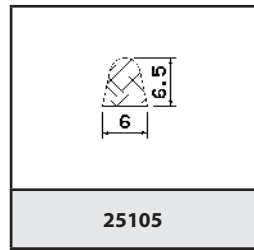

25105

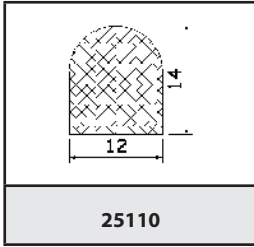

25110

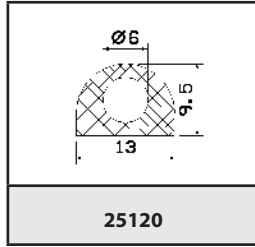

25120

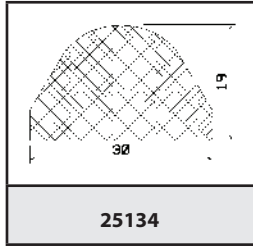

25134

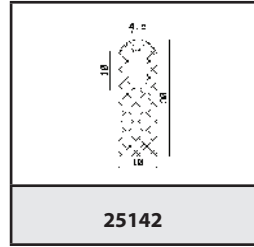

25142

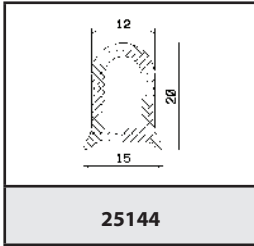

25144

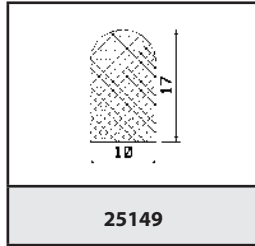

25149

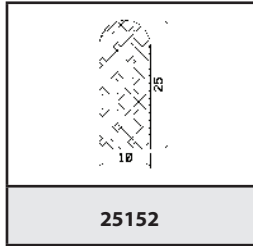

25152

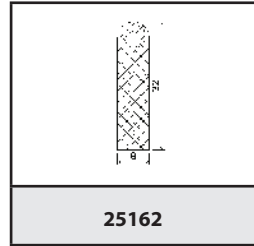

25162

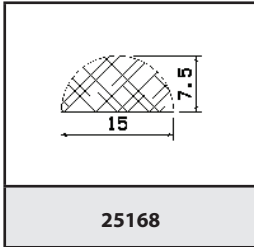

25168

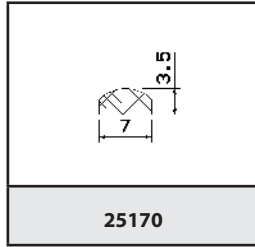

25170

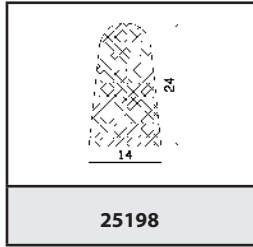

25198

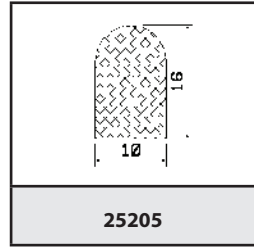

25205

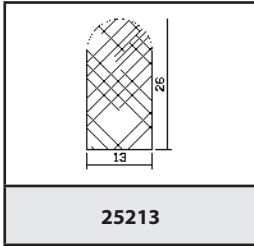

25213

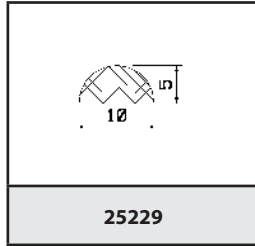

25229

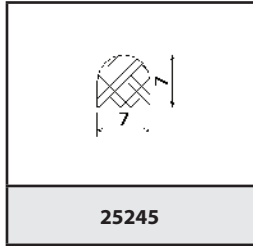

25245

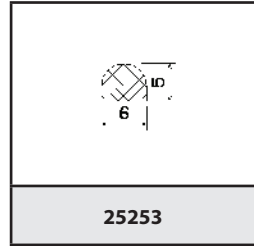

25253

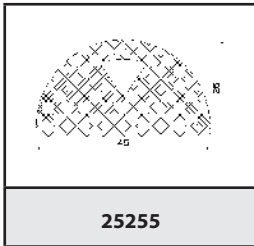

25255

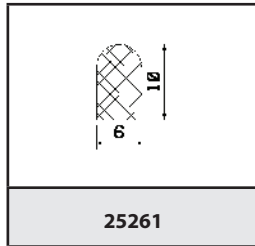

25261

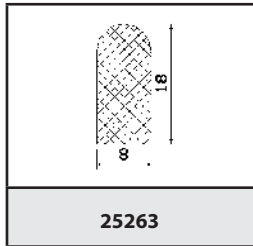

25263

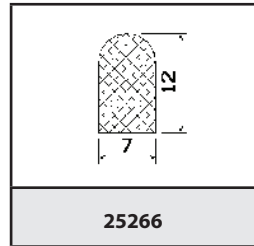

25266

○ foam, foam / silicone

● rubber, silicone

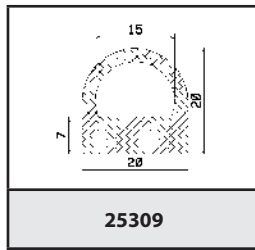

25309

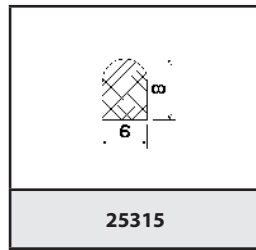

25315

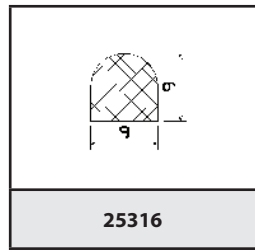

25316

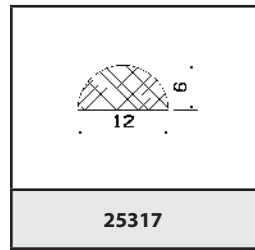

25317

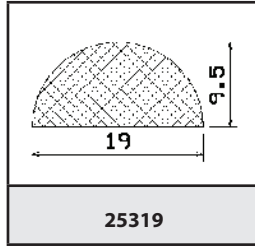

25319

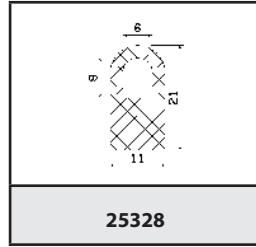

25328

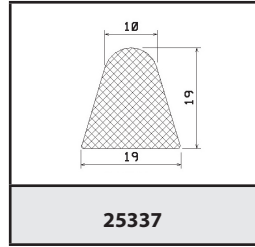

25337

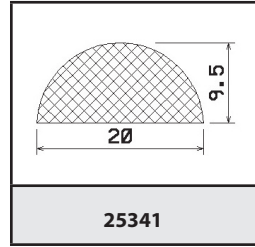

25341

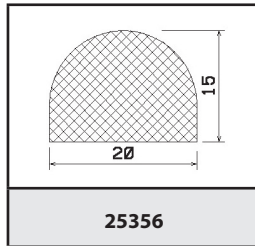

25356

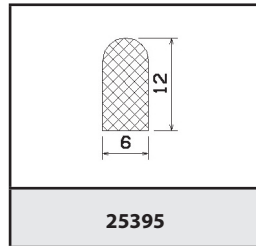

25395

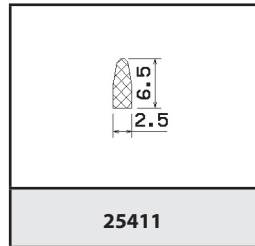

25411

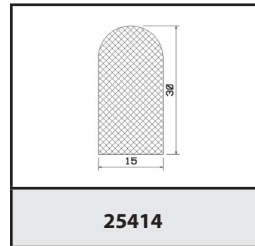

25414

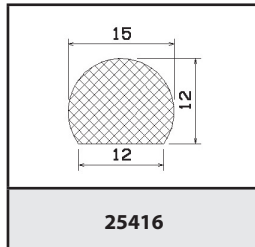

25416

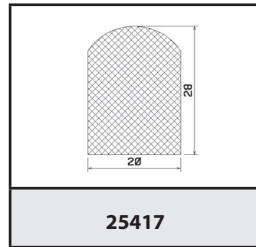

25417

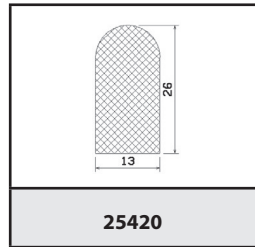

25420

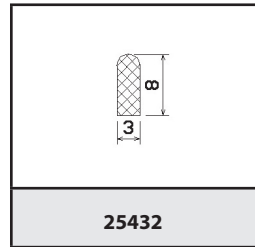

25432

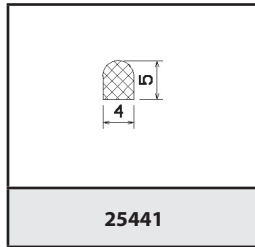

25441

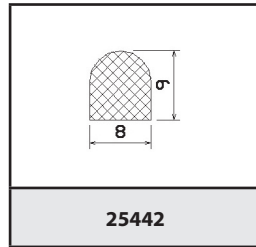

25442

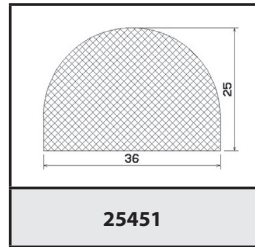

25451

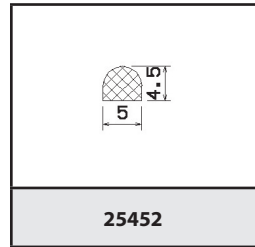

25452

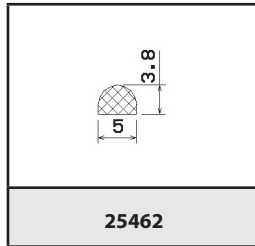

25462

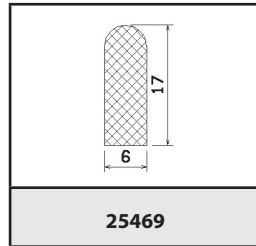

25469

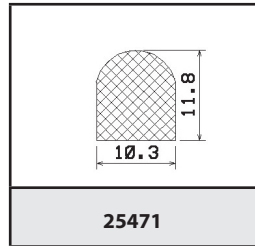

25471

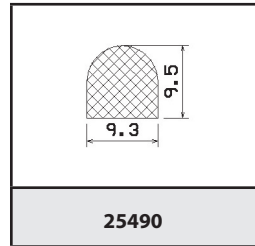

25490



foam, foam / silicone



rubber, silicone

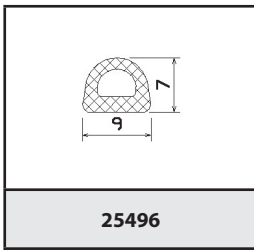

25496

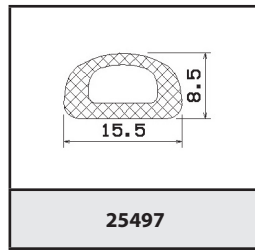

25497

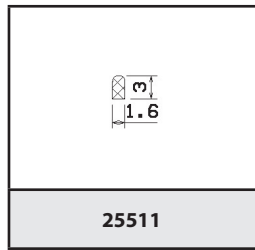

25511

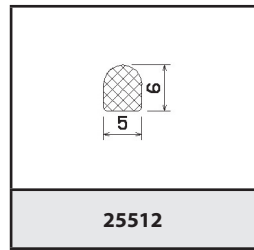

25512

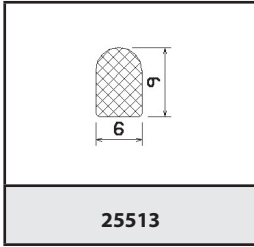

25513

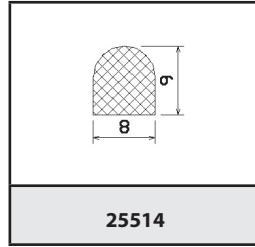

25514

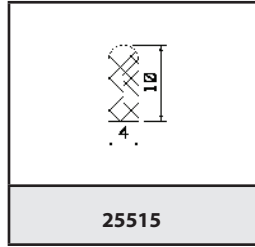

25515

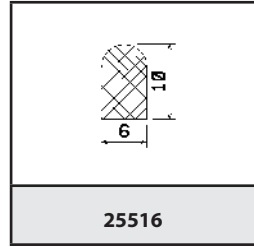

25516

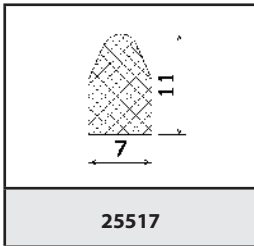

25517

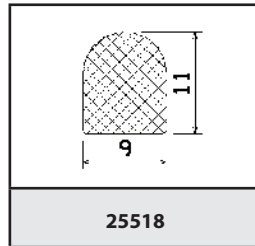

25518

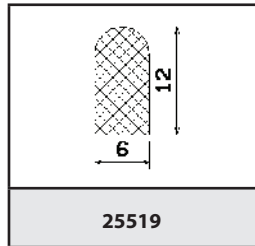

25519

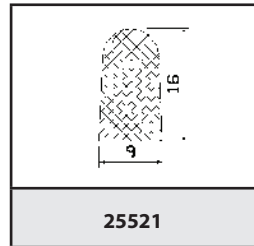

25521

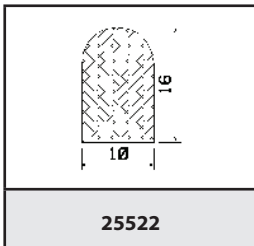

25522

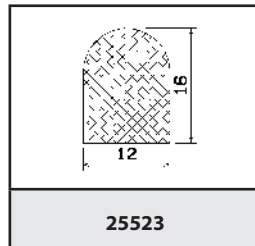

25523

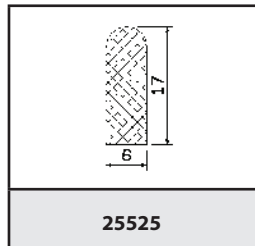

25525

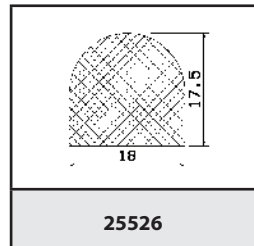

25526

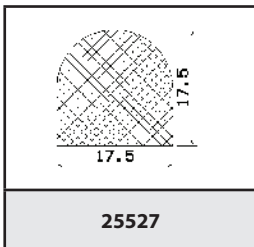

25527

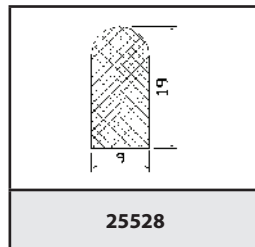

25528

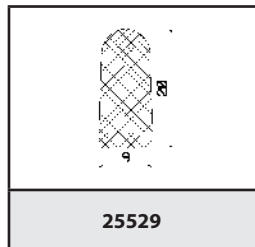

25529

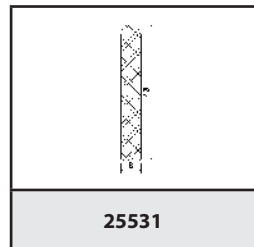

25531

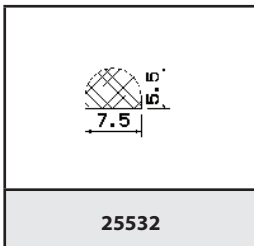

25532

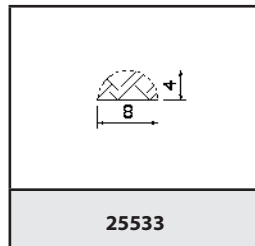

25533

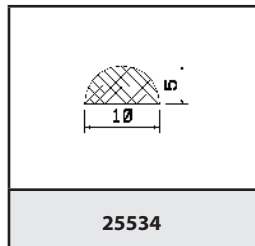

25534

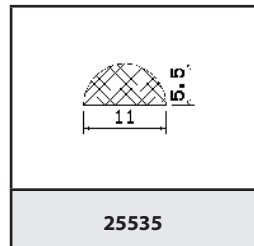

25535

○ foam, foam / silicone

● rubber, silicone

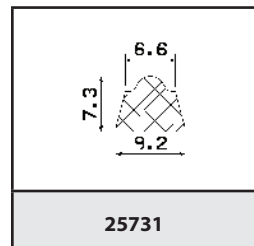
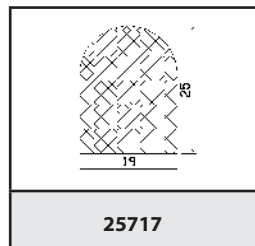
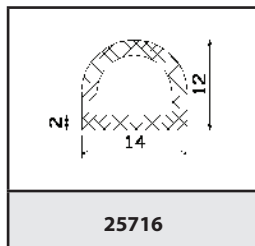
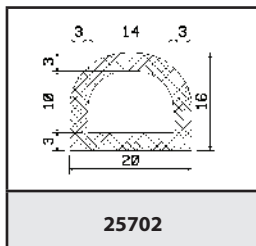
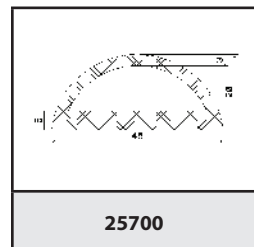
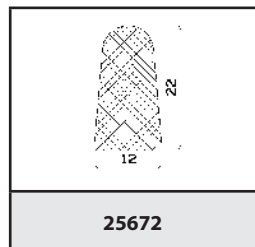
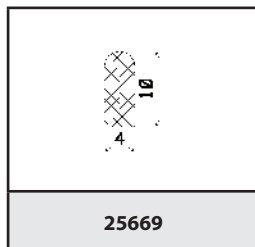
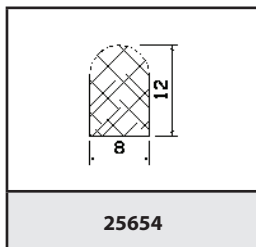
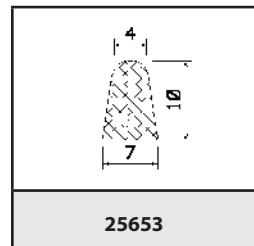
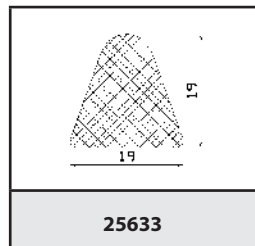
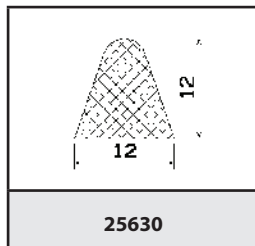
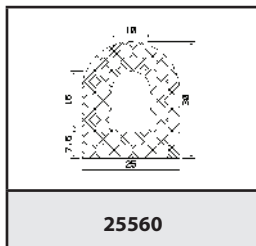
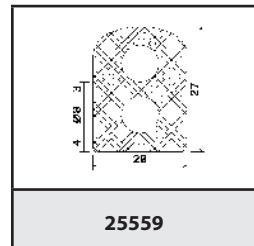
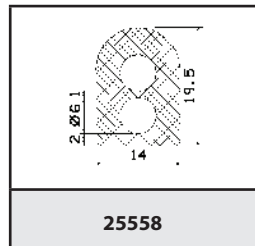
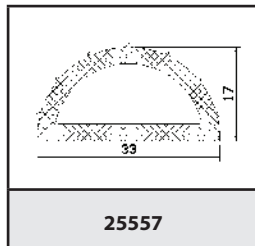
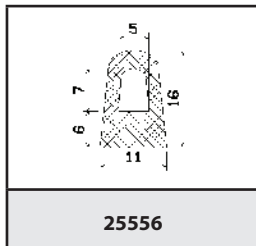
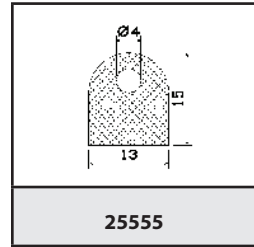
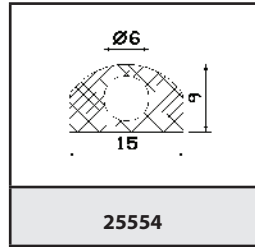
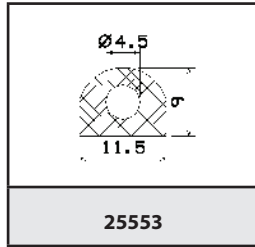
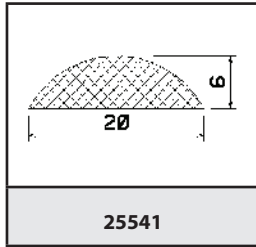
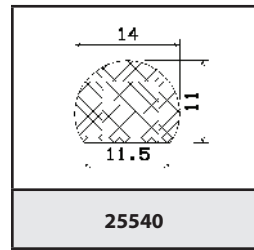
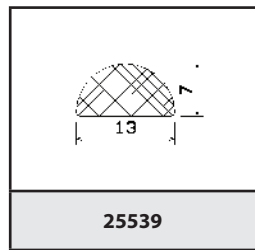
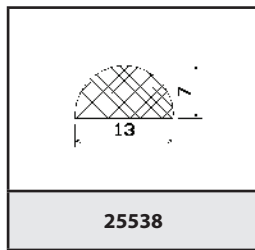
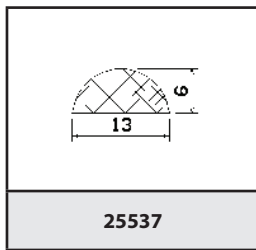

○ foam, foam / silicone

● rubber, silicone

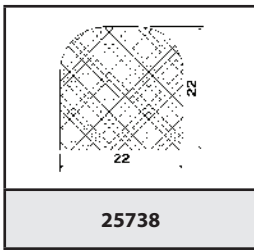

25738

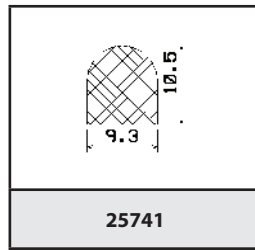

25741

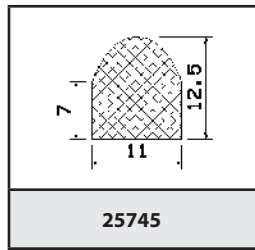

25745

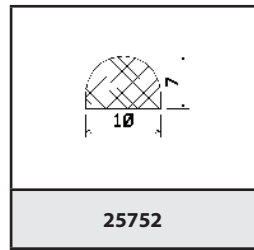

25752

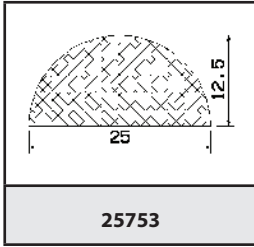

25753

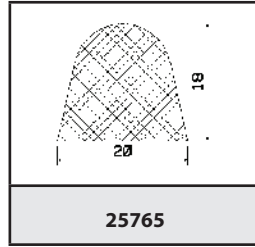

25765

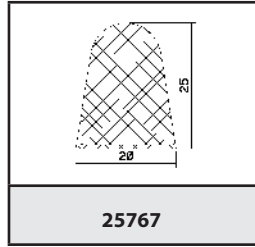

25767

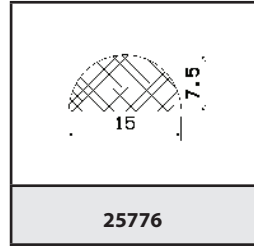

25776

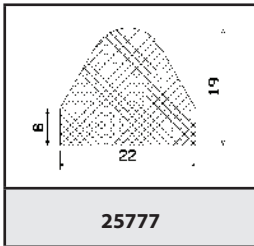

25777

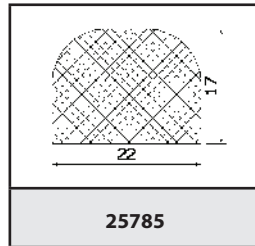

25785

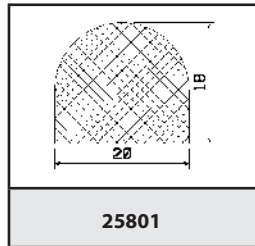

25801

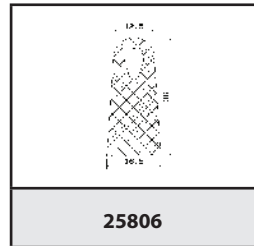

25806

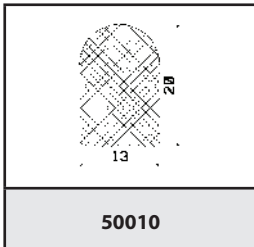

50010

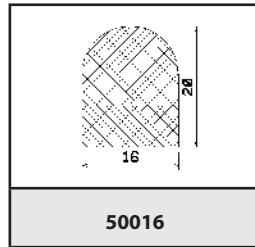

50016

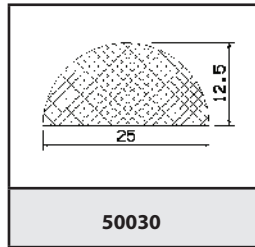

50030

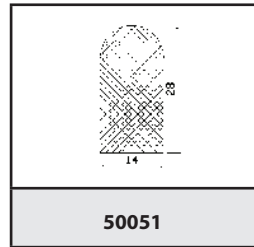

50051

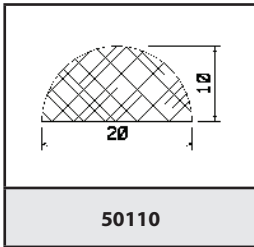

50110

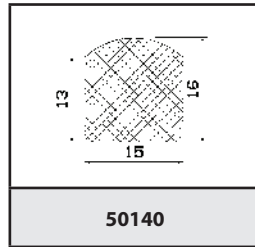

50140

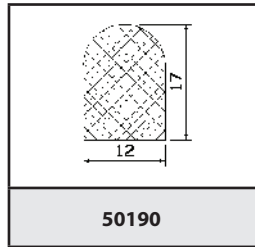

50190

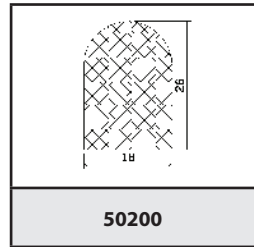

50200

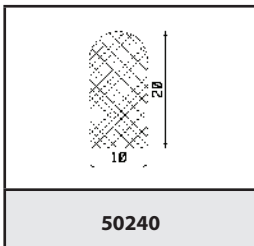

50240

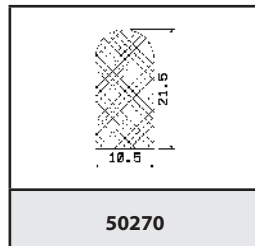

50270

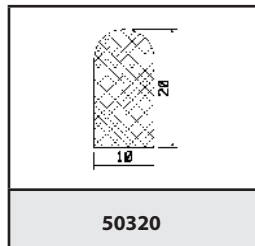

50320

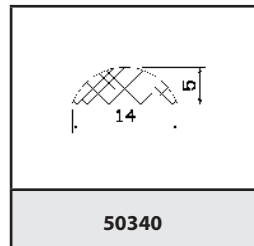

50340

○ foam, foam / silicone

● rubber, silicone

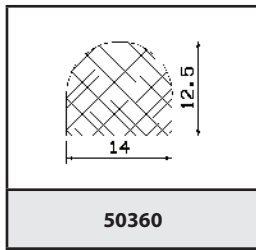

50360

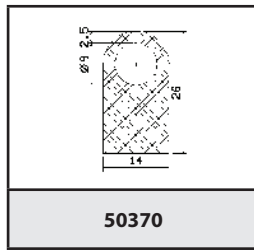

50370

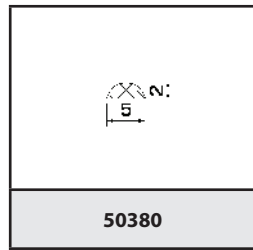

50380

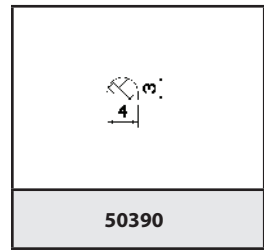

50390

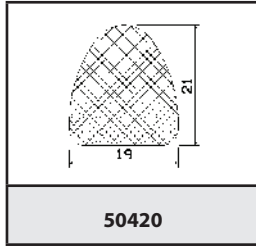

50420

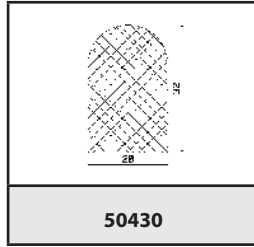

50430

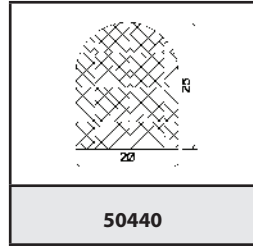

50440

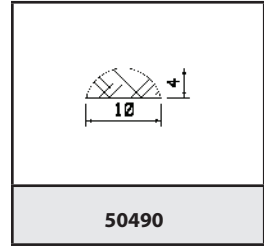

50490

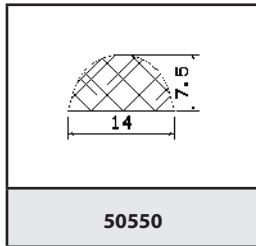

50550

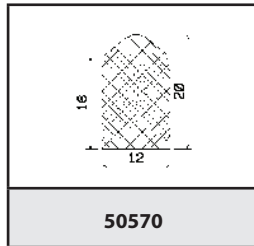

50570

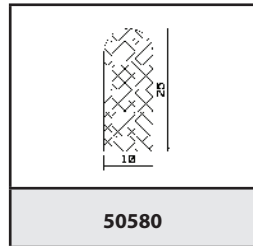

50580

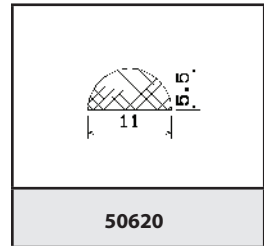

50620

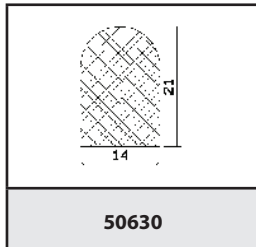

50630

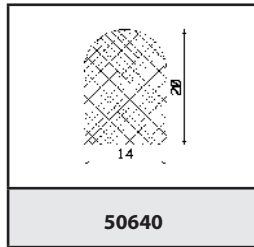

50640

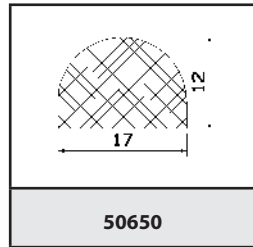

50650

○ foam, foam / silicone

● rubber, silicone

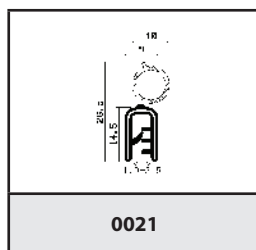

0021

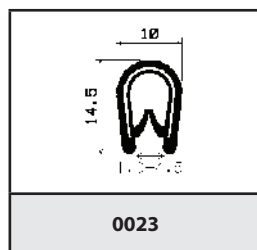

0023

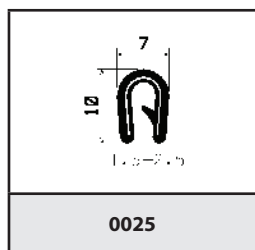

0025

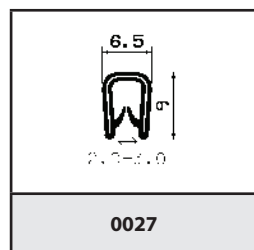

0027

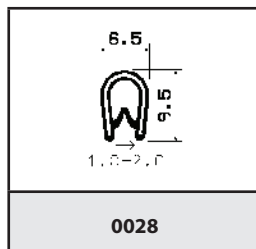

0028

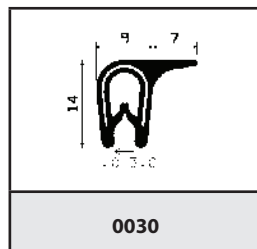

0030

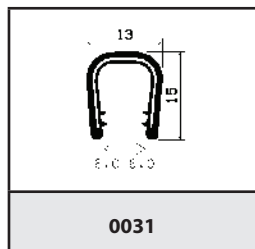

0031

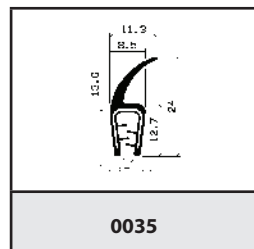

0035

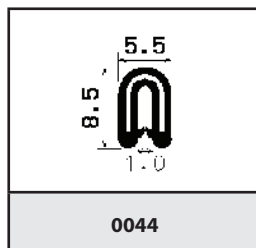

0044

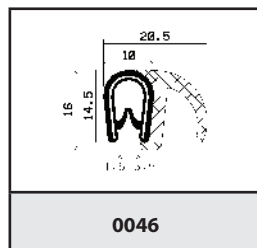

0046

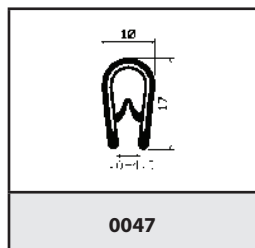

0047

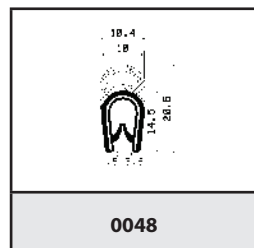

0048

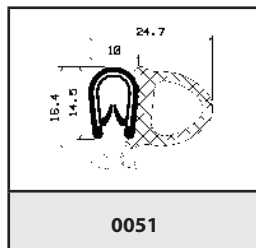

0051

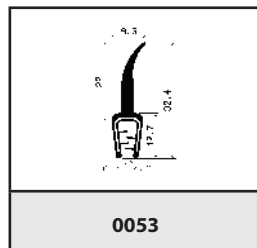

0053

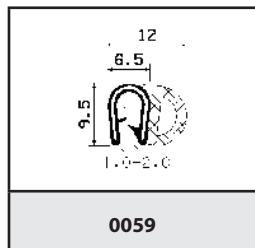

0059

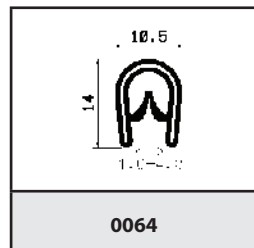

0064

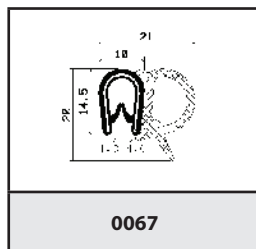

0067

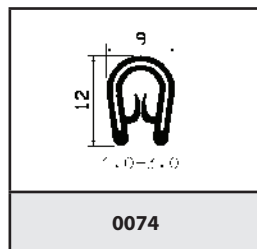

0074

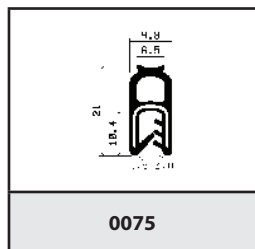

0075

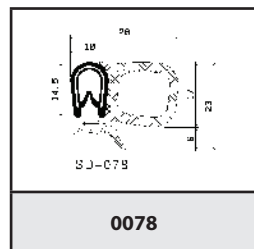

0078

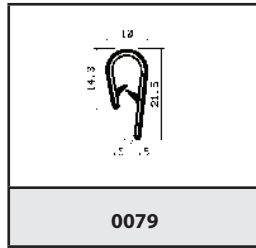

0079

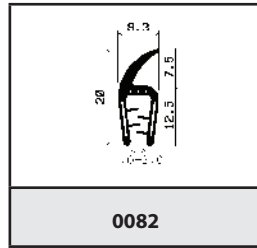

0082

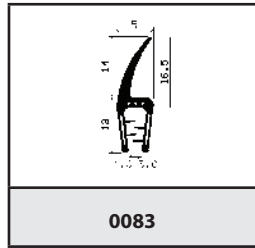

0083

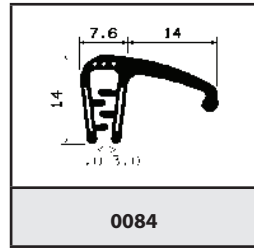

0084

○ foam, foam / silicone

● rubber, silicone

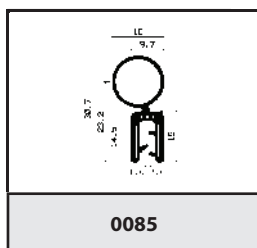

0085

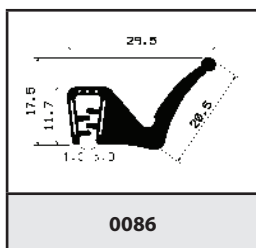

0086

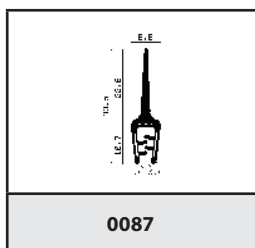

0087

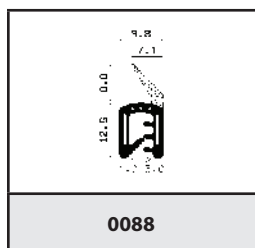

0088

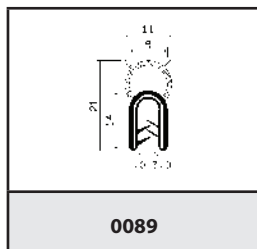

0089

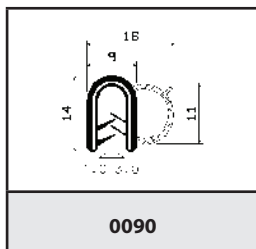

0090

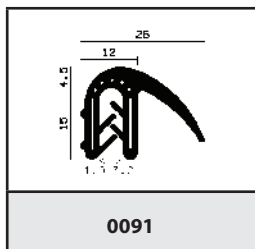

0091

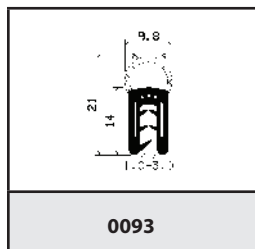

0093

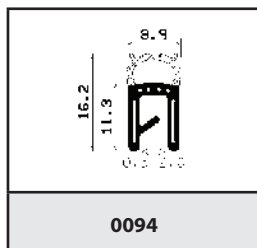

0094

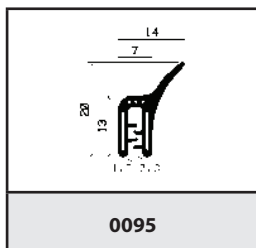

0095

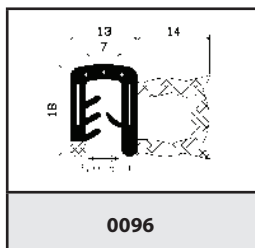

0096

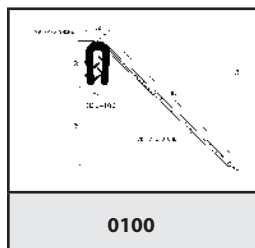

0100

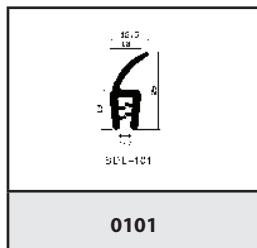

0101

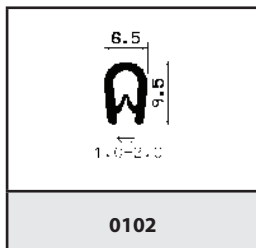

0102

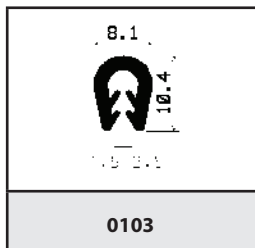

0103

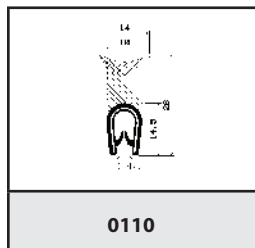

0110

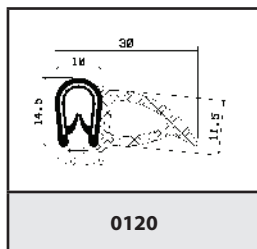

0120

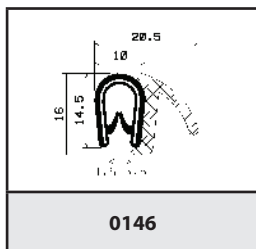

0146

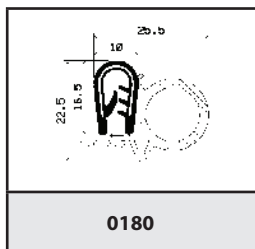

0180

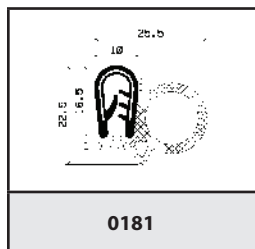

0181

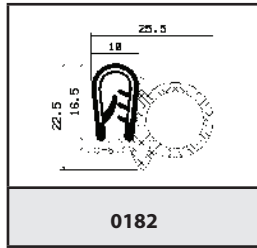

0182

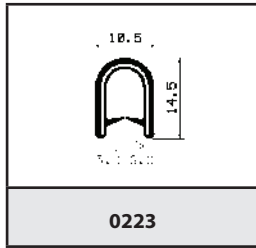

0223

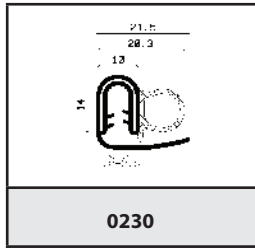

0230

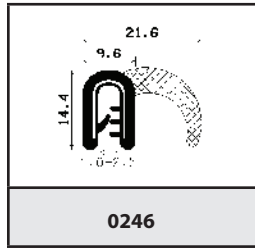

0246

○ foam, foam / silicone

● rubber, silicone

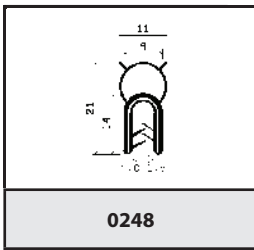

0248

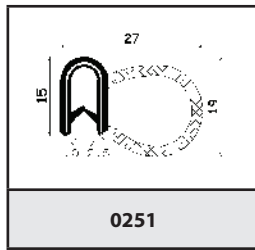

0251

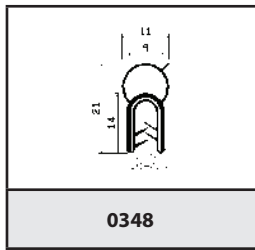

0348

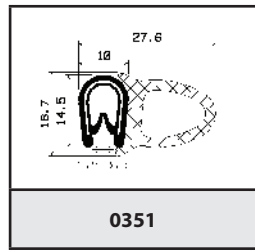

0351

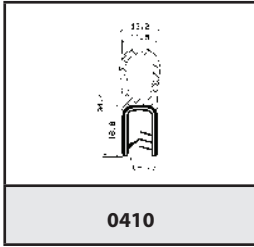

0410

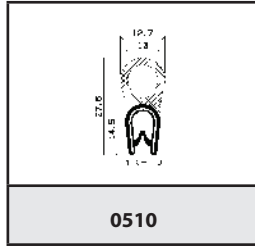

0510

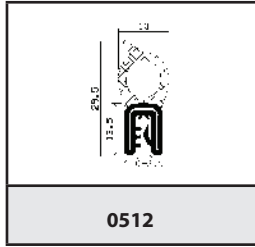

0512

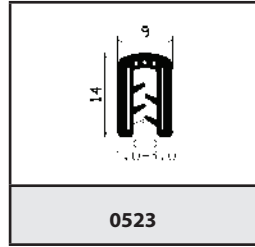

0523

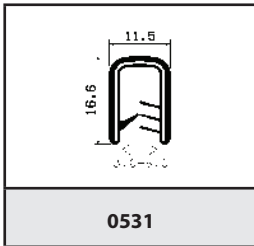

0531

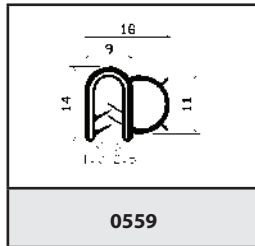

0559

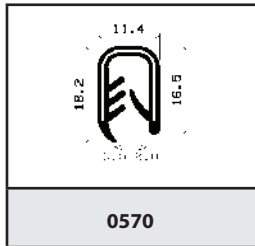

0570

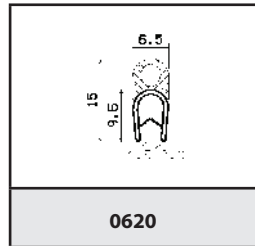

0620

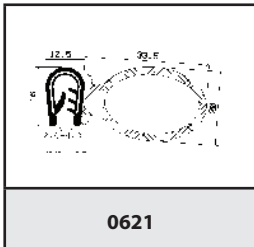

0621

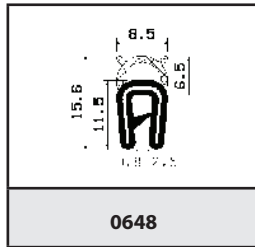

0648

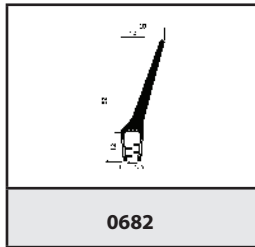

0682

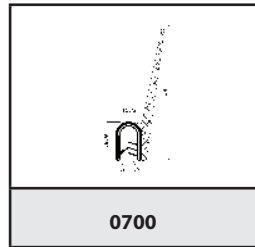

0700

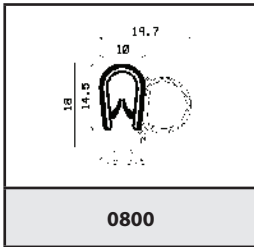

0800

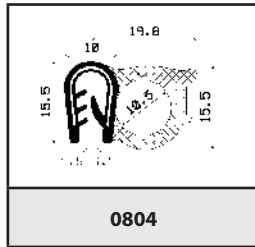

0804

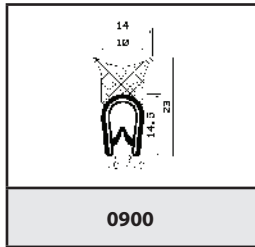

0900

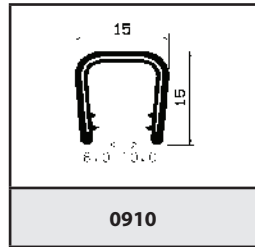

0910

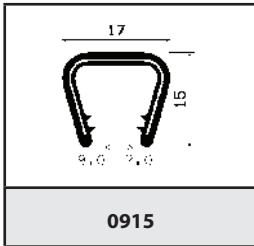

0915

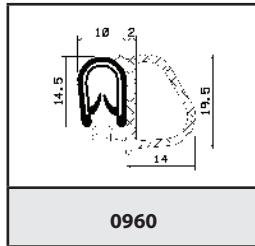

0960

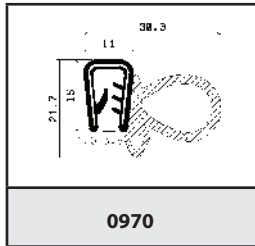

0970

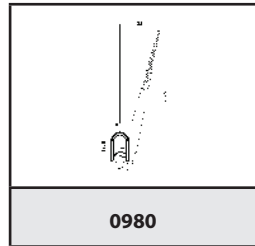

0980

○ foam, foam / silicone

● rubber, silicone

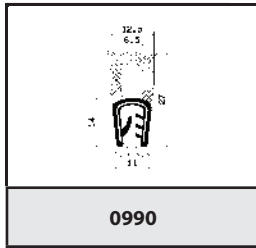

0990

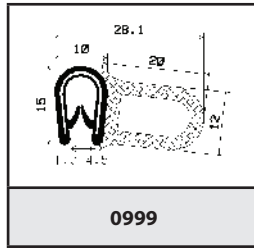

0999

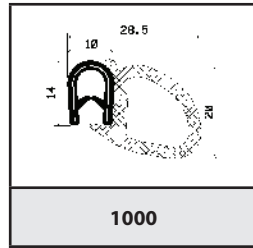

1000

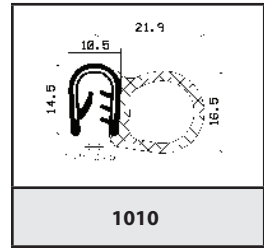

1010

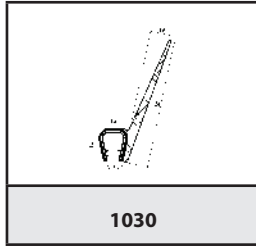



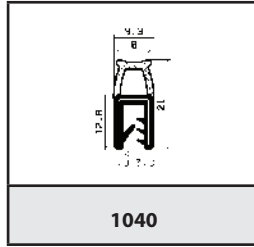













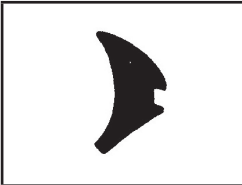

1030

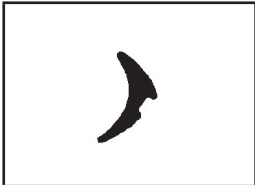

1040

○ foam, foam / silicone

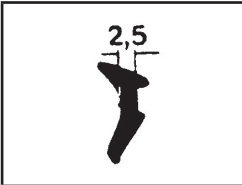
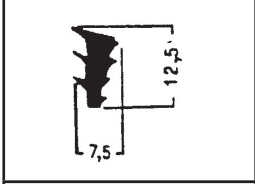
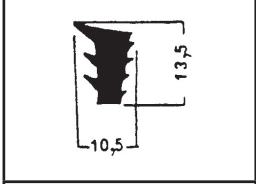
● rubber, silicone

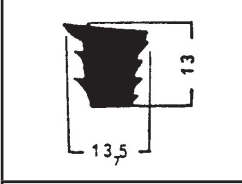
			
0015	0025	0035	0063
			
0096.3	0096.4	0096.5	0096.6
			
0107	0108	0110	0130
			
0138	0153	0167	0201
			
0202	0224	0284	0295
			
0324	0325	0326	0327

○ foam, foam / silicone

● rubber, silicone

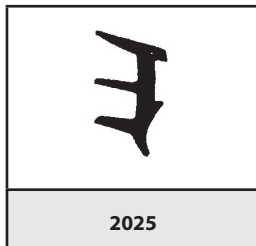
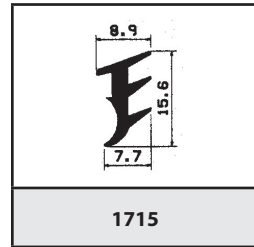
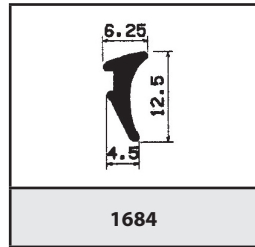
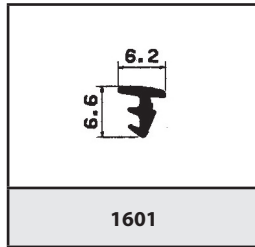
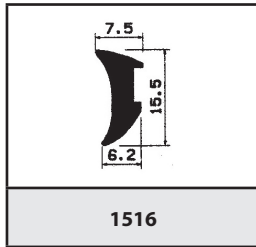
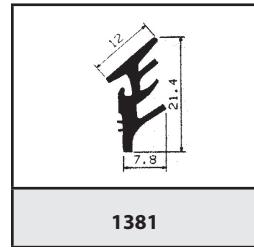
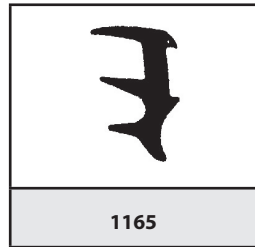
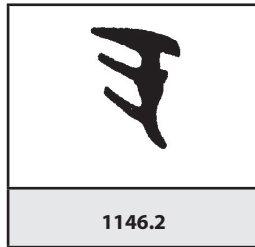
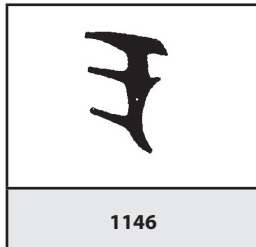
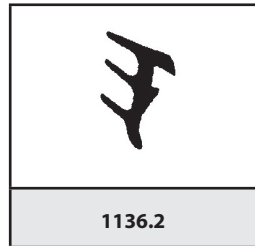
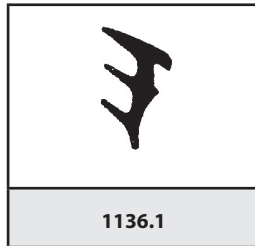
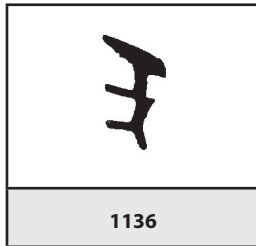
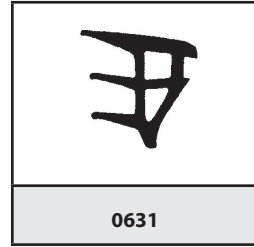
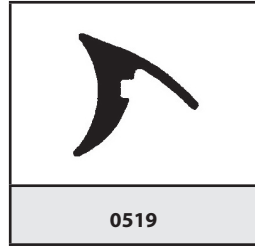
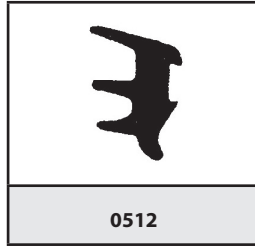
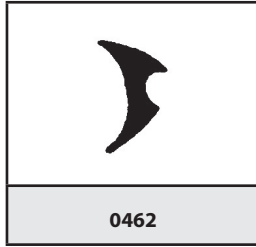
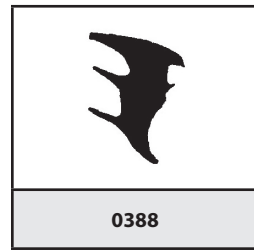
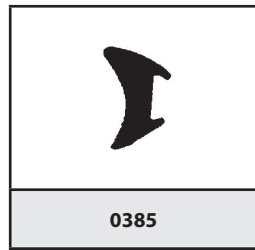
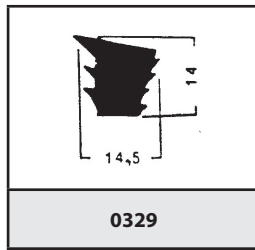
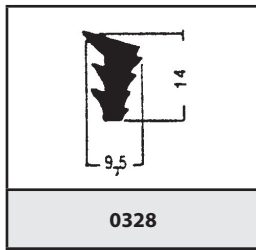

○ foam, foam / silicone

● rubber, silicone

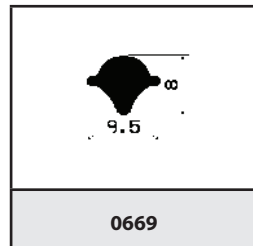
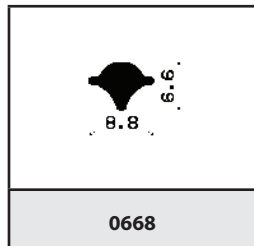
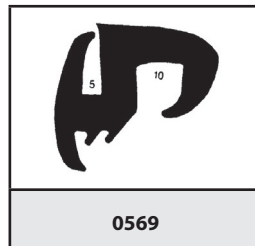
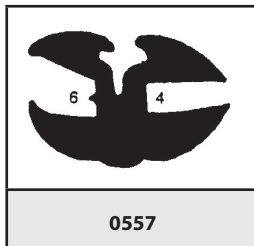
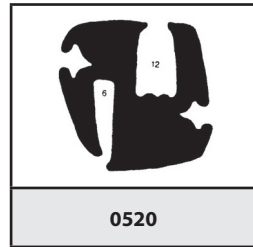
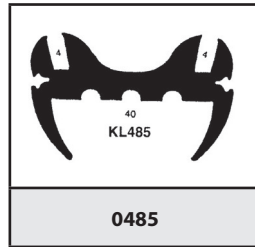
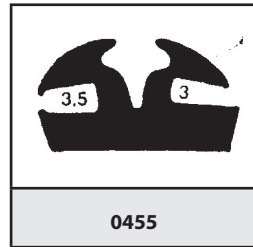
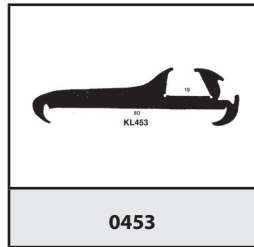
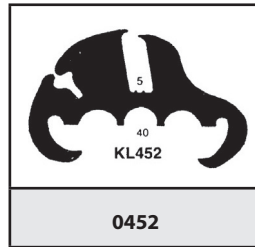
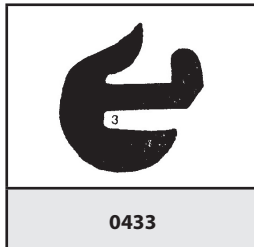
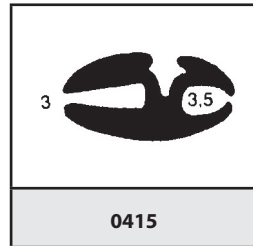
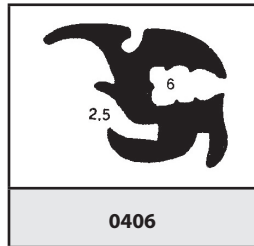
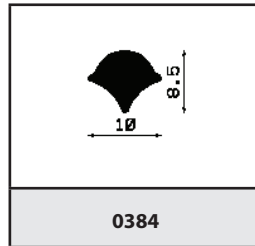
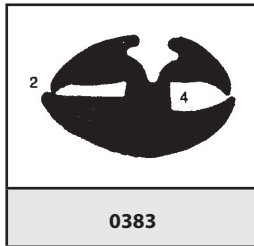
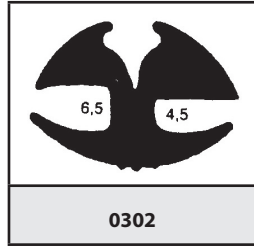
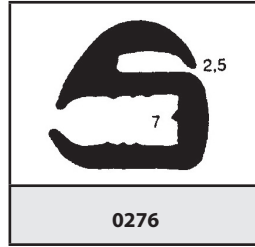
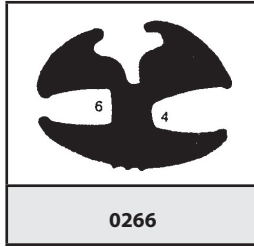
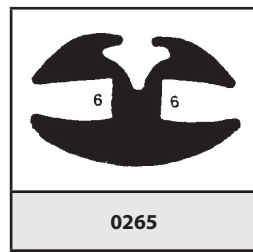
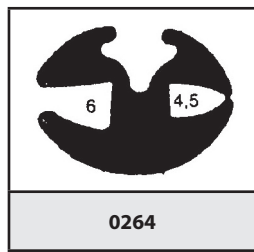
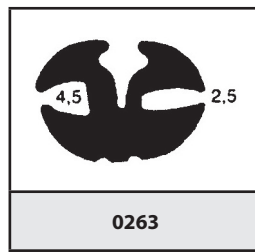
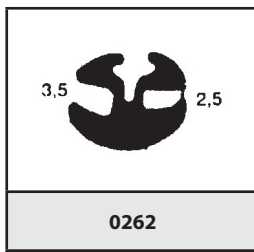

○ foam, foam / silicone

● rubber, silicone

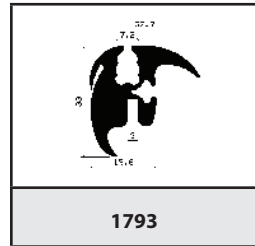
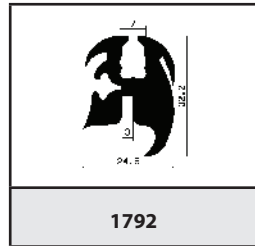
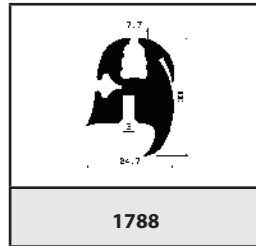
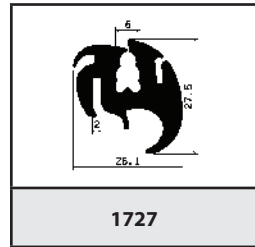
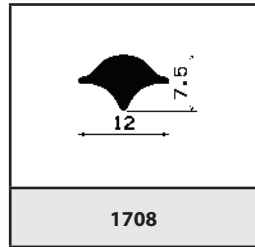
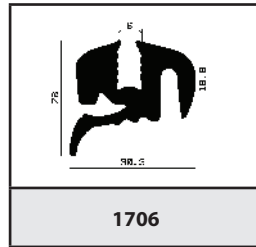
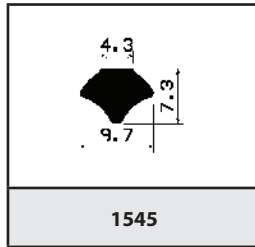
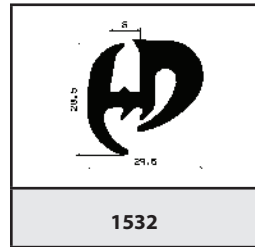
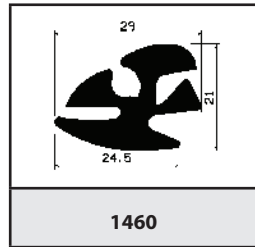
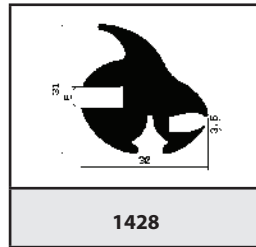
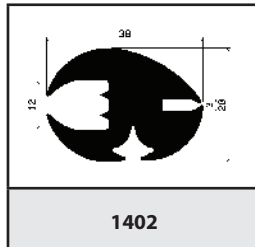
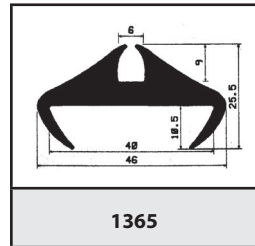
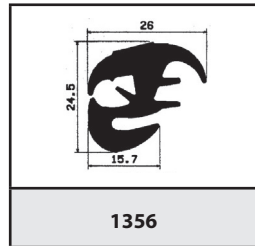
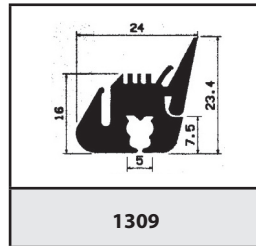
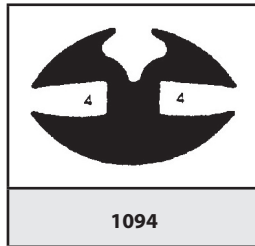
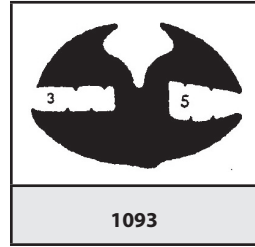
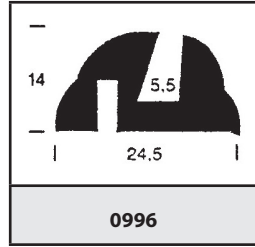
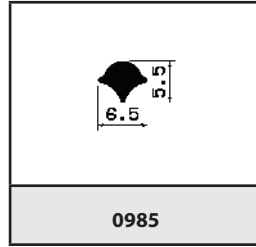
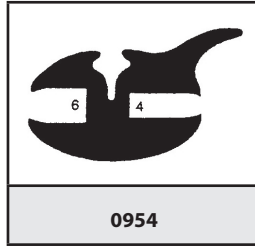
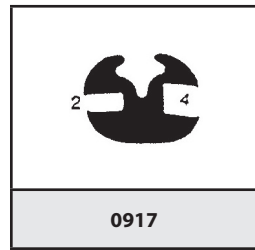
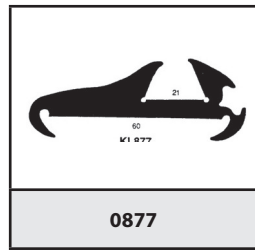
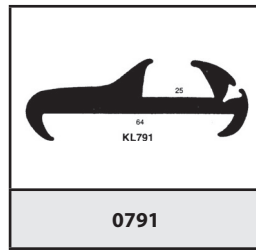
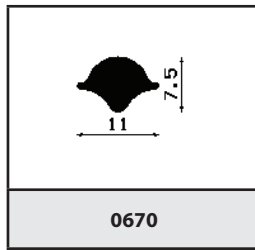

○ foam, foam / silicone

● rubber, silicone

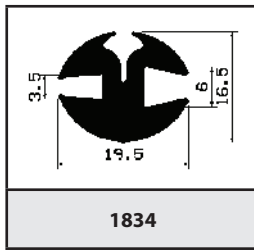

1834

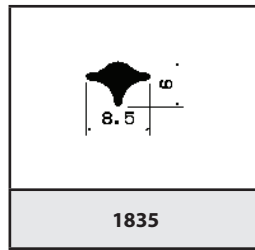

1835

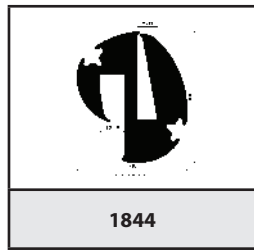

1844

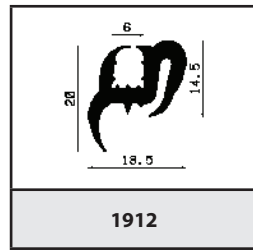

1912

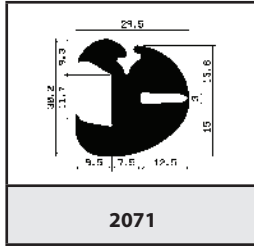

2071

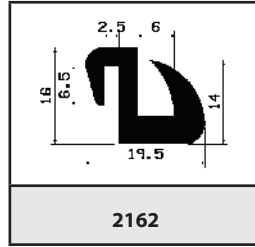

2162

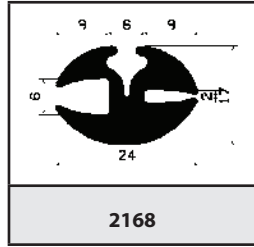

2168

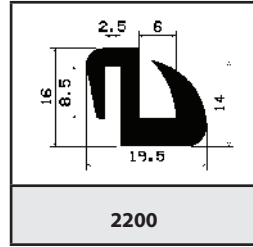

2200

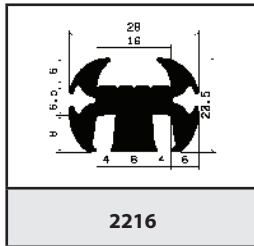

2216

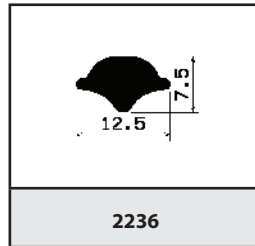

2236

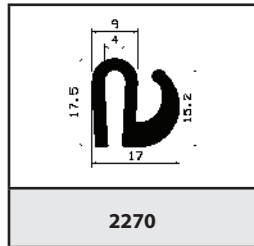

2270

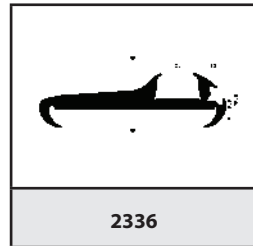

2336

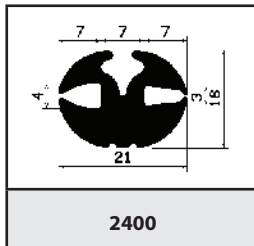

2400

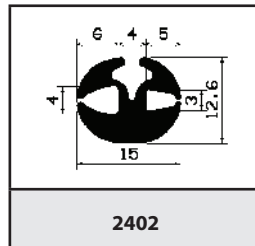

2402

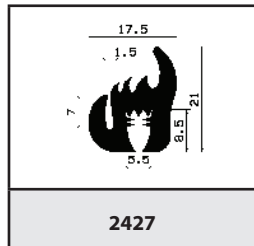

2427

○ foam, foam / silicone

● rubber, silicone

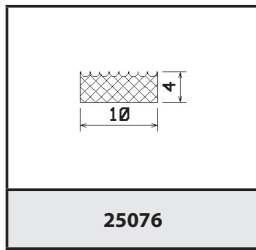

25076

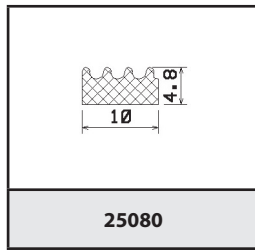

25080

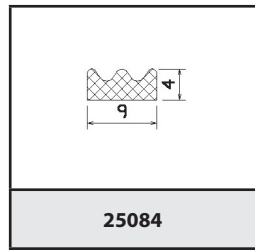

25084

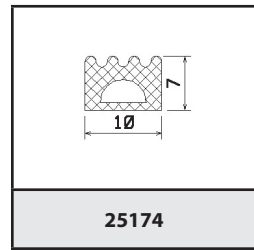

25174

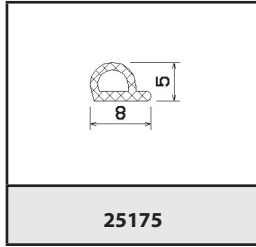

25175

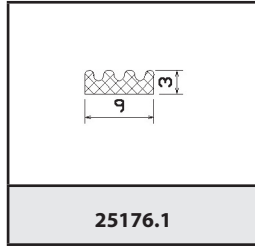

25176.1

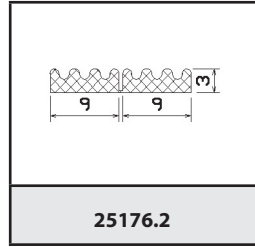

25176.2

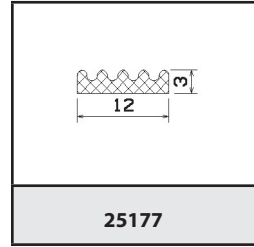

25177

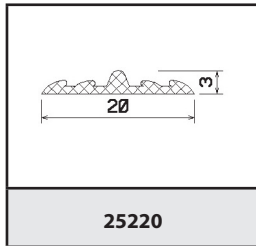

25220

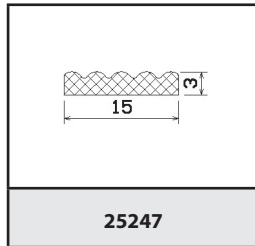

25247

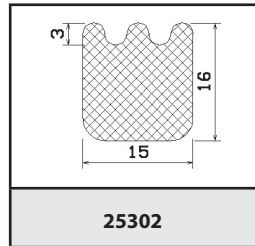

25302

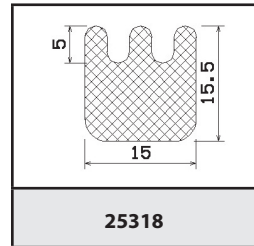

25318

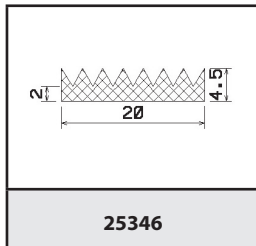

25346

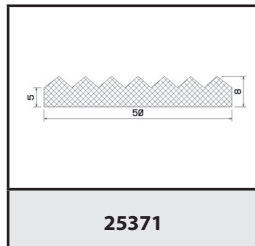

25371

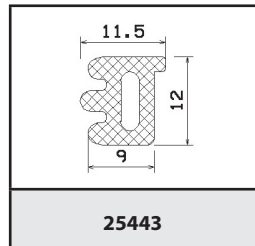

25443

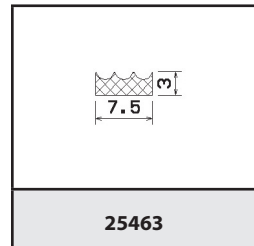

25463

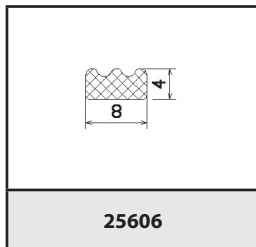

25606

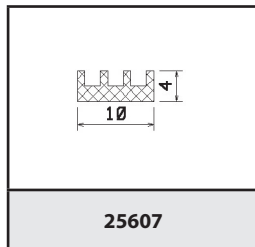

25607

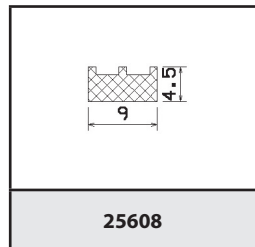

25608

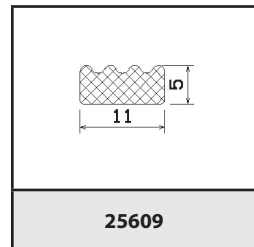

25609

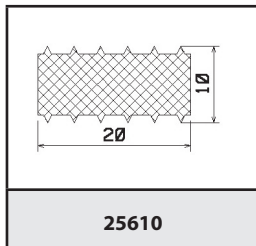

25610

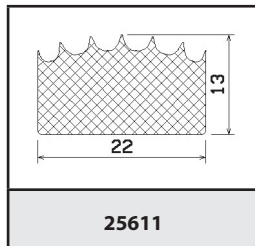

25611

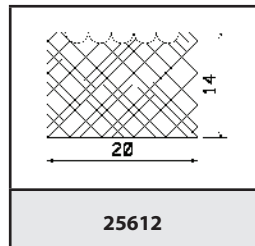

25612

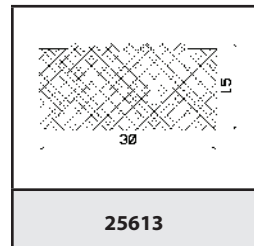

25613

○ foam, foam / silicone

● rubber, silicone

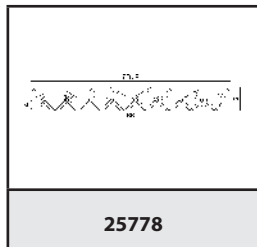
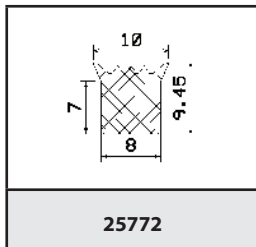
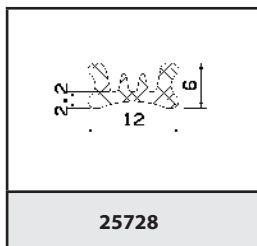
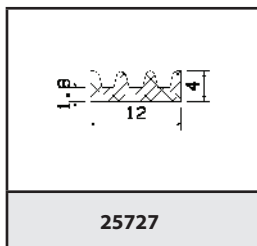
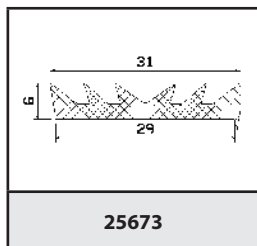
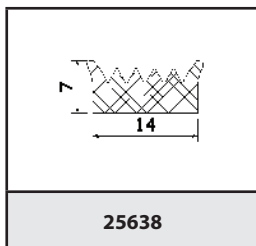

○ foam, foam / silicone

● rubber, silicone

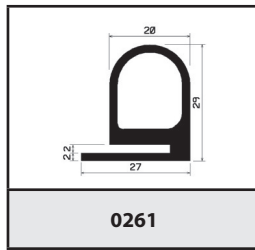

0261

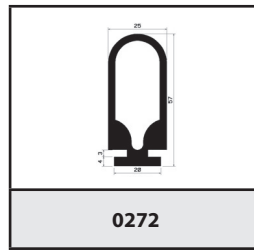

0272

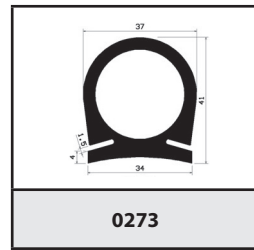

0273

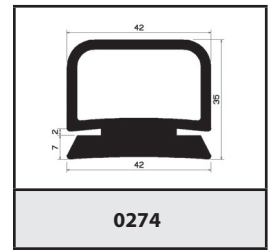

0274

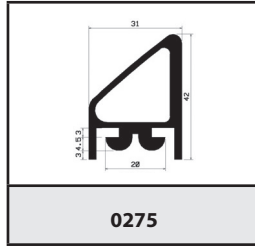

0275

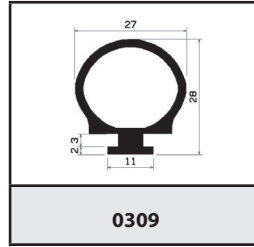

0309

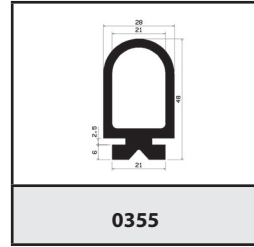

0355

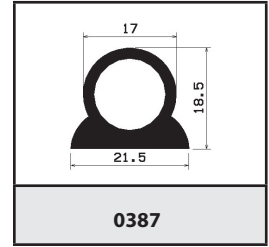

0387

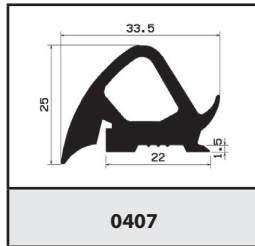

0407

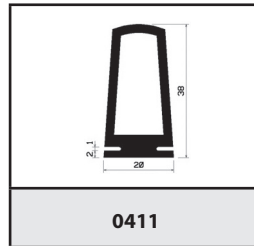

0411

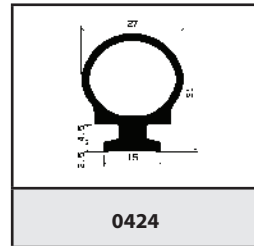

0424

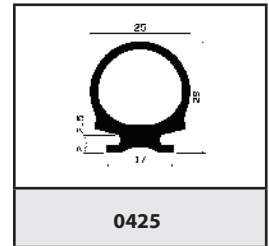

0425

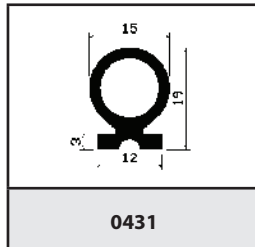

0431

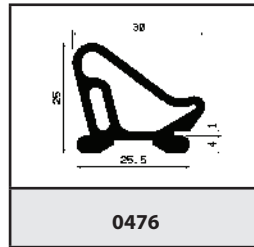

0476

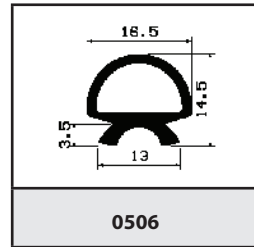

0506

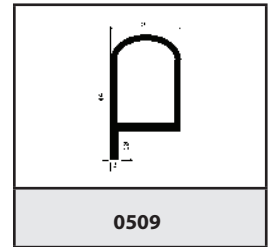

0509

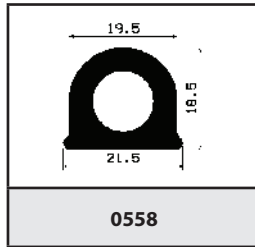

0558

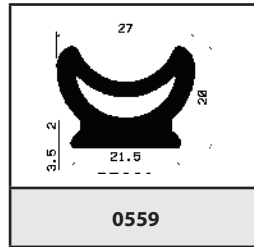

0559

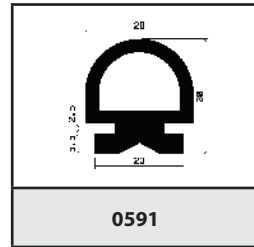

0591

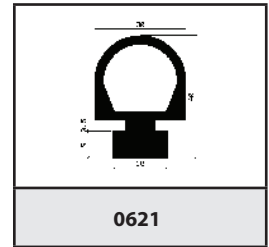

0621

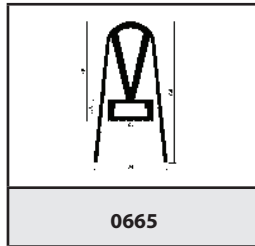

0665

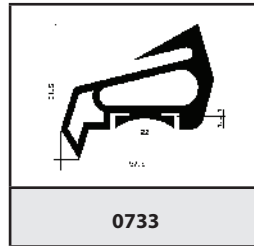

0733

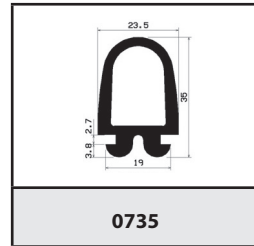

0735

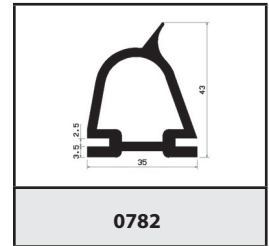

0782

○ foam, foam / silicone

● rubber, silicone

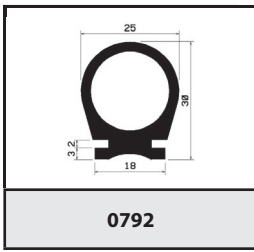

0792

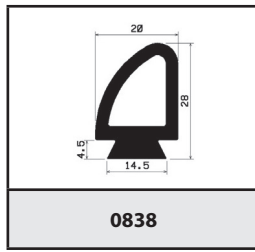

0838

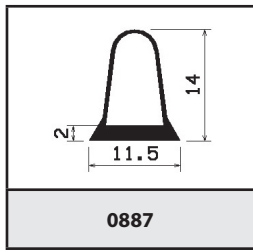

0887

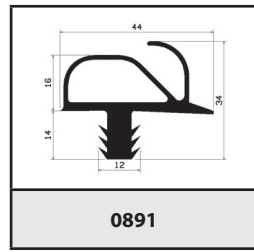

0891

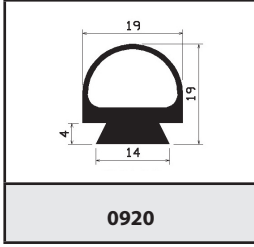

0920

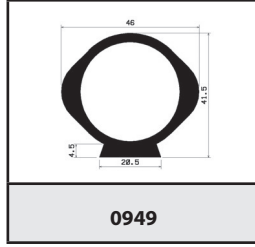

0949

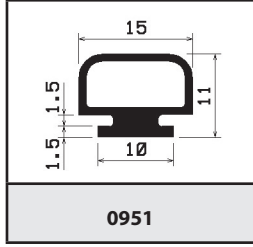

0951

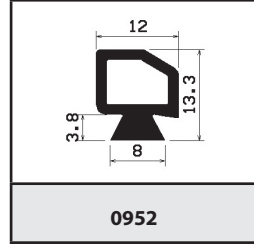

0952

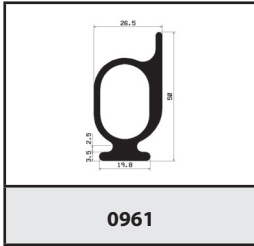

0961

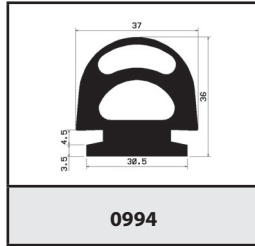

0994

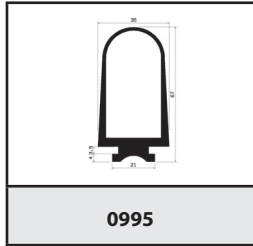

0995

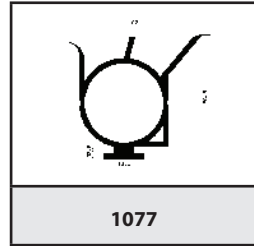

1077

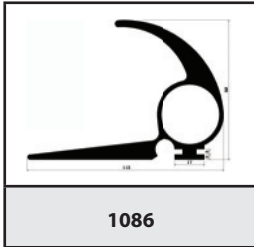

1086

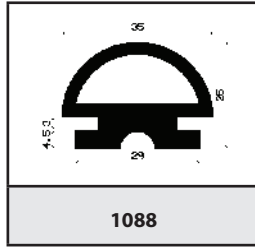

1088

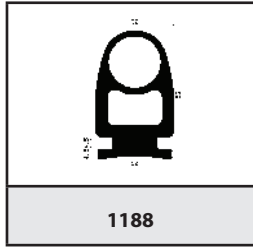

1188

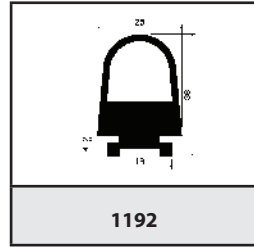

1192

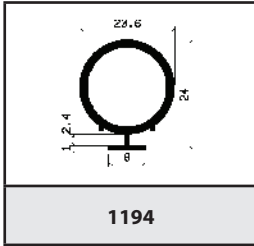

1194

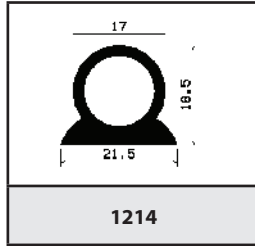

1214

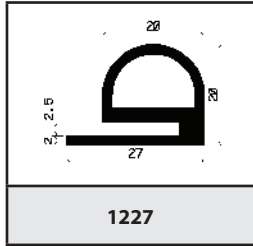

1227

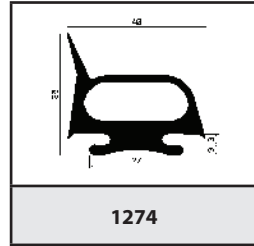

1274

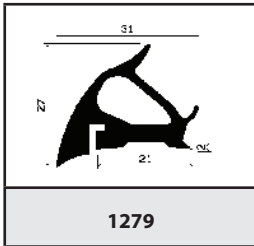

1279

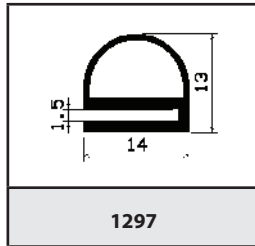

1297

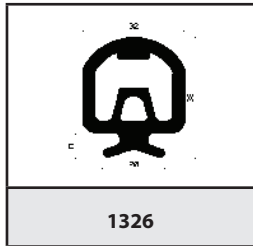

1326

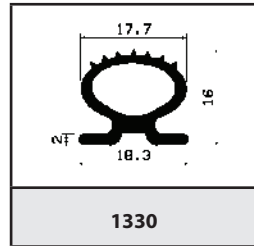

1330

○ foam, foam / silicone

● rubber, silicone

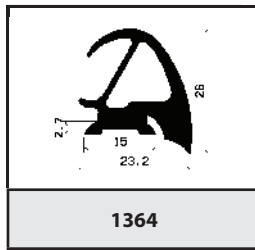

1364

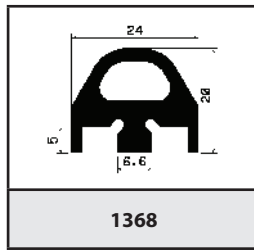

1368

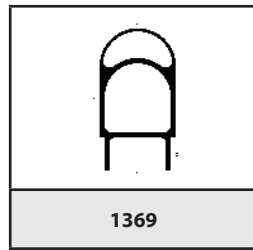

1369

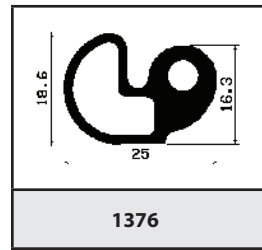

1376

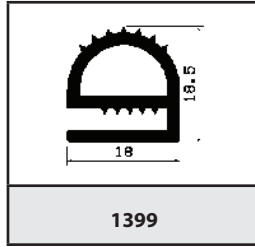

1399

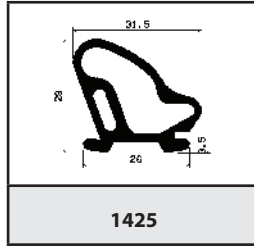

1425

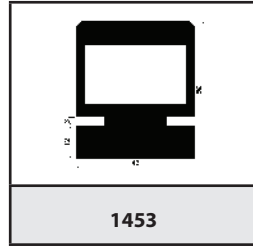

1453

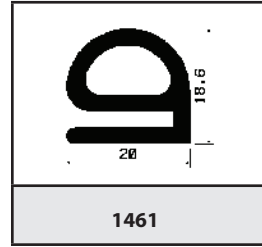

1461

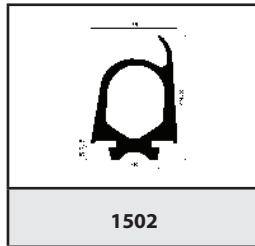

1502

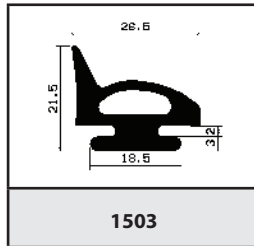

1503

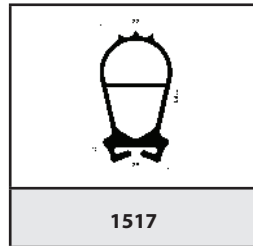

1517

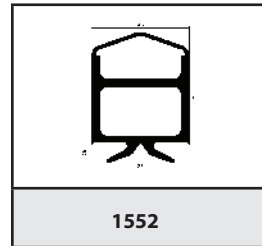

1552

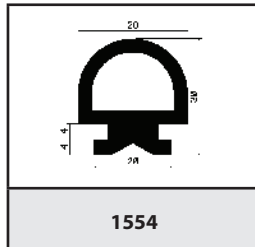

1554

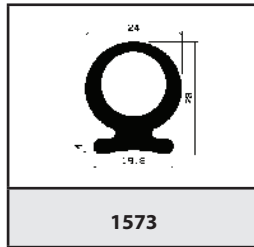

1573

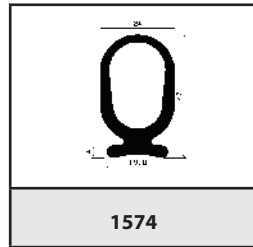

1574

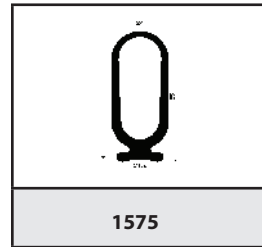

1575

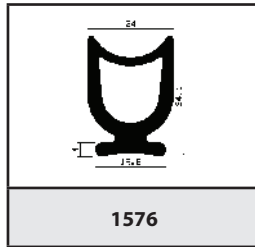

1576

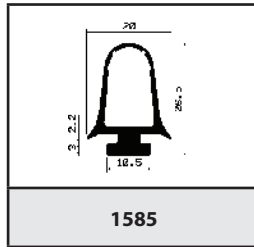

1585

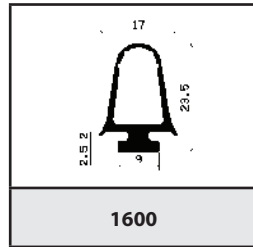

1600

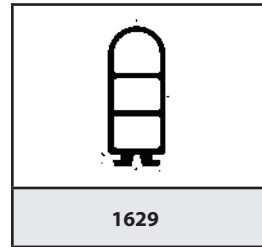

1629

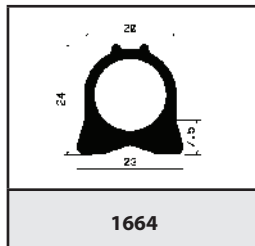

1664

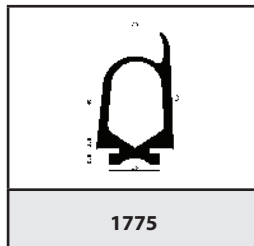

1775

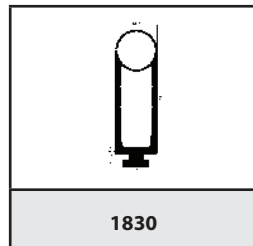

1830

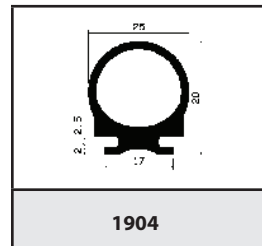

1904



foam, foam / silicone



rubber, silicone

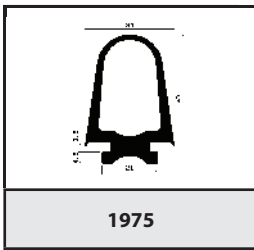

1975

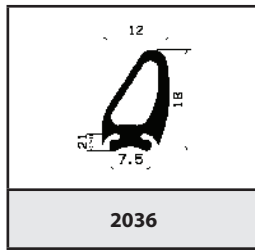

2036

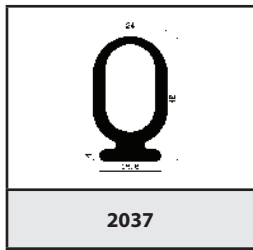

2037

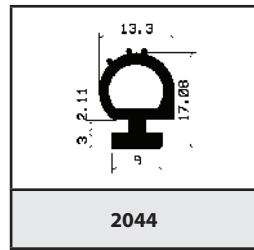

2044

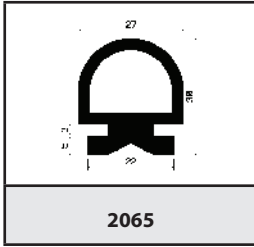

2065

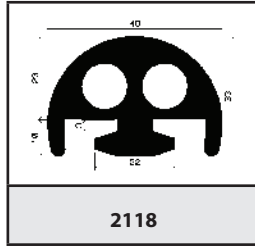

2118

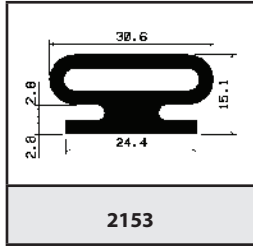

2153

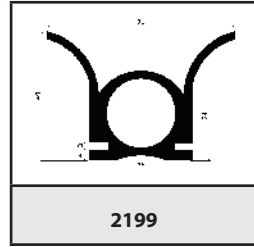

2199

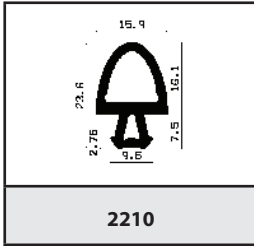

2210

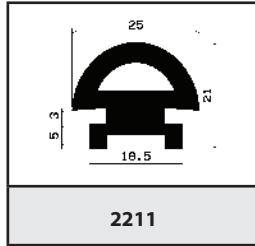

2211

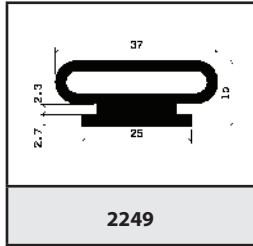

2249

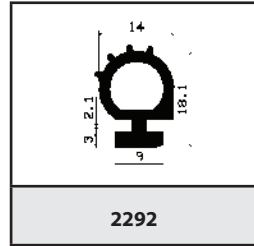

2292

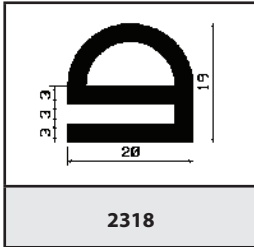

2318

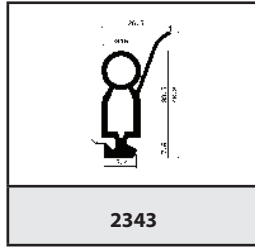

2343

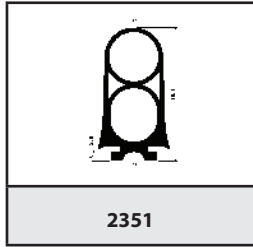

2351

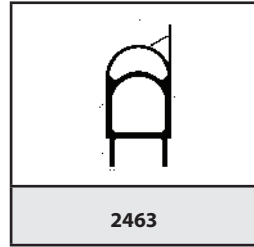

2463

○ foam, foam / silicone

● rubber, silicone

rubber (EPDM, CR, NBR, NR)	foam (EPDM, CR)	silicone		silicone foam
Ř 01,00mm	Ř 01,00mm	Ř 00,60mm	Ř 12,00mm	Ř 01,00mm
Ř 01,50mm	Ř 01,50mm	Ř 01,00mm	Ř 12,50mm	Ř 01,50mm
Ř 01,55mm	Ř 02,00mm	Ř 01,50mm	Ř 13,00mm	Ř 02,00mm
Ř 01,60mm	Ř 02,50mm	Ř 01,55mm	Ř 13,50mm	Ř 02,50mm
Ř 01,78mm	Ř 02,80mm	Ř 01,60mm	Ř 14,00mm	Ř 03,00mm
Ř 02,00mm	Ř 03,00mm	Ř 01,78mm	Ř 14,50mm	Ř 03,50mm
Ř 02,50mm	Ř 03,50mm	Ř 01,80mm	Ř 15,00mm	Ř 04,00mm
Ř 02,62mm	Ř 04,00mm	Ř 02,00mm	Ř 15,50mm	Ř 04,50mm
Ř 03,00mm	Ř 04,50mm	Ř 02,40mm	Ř 16,00mm	Ř 05,00mm
Ř 03,20mm	Ř 05,00mm	Ř 02,50mm	Ř 16,50mm	Ř 05,50mm
Ř 03,50mm	Ř 05,80mm	Ř 02,62mm	Ř 17,00mm	Ř 06,00mm
Ř 04,00mm	Ř 06,00mm	Ř 03,00mm	Ř 17,50mm	Ř 06,50mm
Ř 04,50mm	Ř 06,50mm	Ř 03,20mm	Ř 18,00mm	Ř 07,00mm
Ř 05,00mm	Ř 07,00mm	Ř 03,35mm	Ř 18,50mm	Ř 08,00mm
Ř 05,33mm	Ř 07,50mm	Ř 03,50mm	Ř 19,00mm	Ř 12,00mm
Ř 05,50mm	Ř 08,00mm	Ř 04,00mm	Ř 19,50mm	Ř 15,00mm
Ř 05,70mm	Ř 09,60mm	Ř 04,50mm	Ř 20,00mm	Ř 18,00mm
Ř 06,00mm	Ř 10,00mm	Ř 05,00mm	Ř 20,50mm	Ř 20,00mm
Ř 06,50mm	Ř 11,00mm	Ř 05,33mm	Ř 21,00mm	Ř 22,00mm
Ř 06,60mm	Ř 12,00mm	Ř 05,50mm	Ř 21,50mm	Ř 25,00mm
Ř 07,00mm	Ř 13,00mm	Ř 05,70mm	Ř 22,00mm	Ř 30,00mm
Ř 07,50mm	Ř 13,50mm	Ř 06,00mm	Ř 22,50mm	Ř 32,00mm
Ř 08,00mm	Ř 14,00mm	Ř 06,35mm	Ř 23,00mm	Ř 35,00mm
Ř 08,50mm	Ř 15,00mm	Ř 06,50mm	Ř 23,50mm	Ř 40,00mm
Ř 09,00mm	Ř 16,00mm	Ř 07,00mm	Ř 24,00mm	Ř 43,00mm
Ř 10,00mm	Ř 16,50mm	Ř 07,50mm	Ř 24,50mm	Ř 45,00mm
Ř 11,00mm	Ř 17,00mm	Ř 08,00mm	Ř 25,00mm	Ř 50,00mm
Ř 12,00mm	Ř 18,00mm	Ř 08,50mm	Ř 30,00mm	Ř 60,00mm
Ř 13,00mm	Ř 19,00mm	Ř 09,00mm	Ř 30,00mm	
Ř 14,00mm	Ř 20,00mm	Ř 09,50mm	Ř 35,00mm	
Ř 15,00mm	Ř 22,00mm	Ř 10,00mm	Ř 38,00mm	
Ř 16,00mm	Ř 23,00mm	Ř 10,50mm	Ř 40,00mm	
Ř 17,00mm	Ř 25,00mm	Ř 11,00mm	Ř 45,00mm	
Ř 18,00mm	Ř 28,00mm	Ř 11,50mm	Ř 50,00mm	
Ř 19,00mm	Ř 30,00mm			
Ř 20,00mm	Ř 33,00mm			
Ř 22,00mm	Ř 35,00mm			
Ř 24,00mm	Ř 38,00mm			
Ř 25,00mm	Ř 40,00mm			
Ř 27,50mm	Ř 45,00mm			
Ř 30,00mm	Ř 48,00mm			
Ř 33,00mm	Ř 50,00mm			
Ř 35,00mm	Ř 52,50mm			
Ř 37,00mm	Ř 60,00mm			
Ř 40,00mm				
Ř 45,00mm				
Ř 50,00mm				

The stated dimension can be supplied in all listed materials.

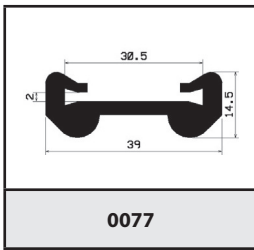

0077

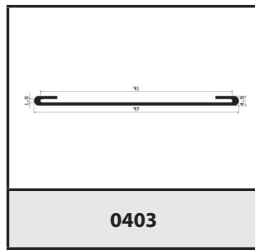

0403

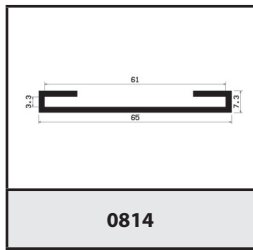

0814

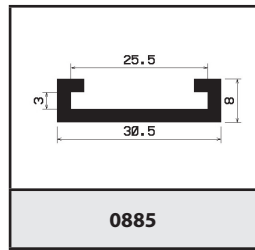

0885

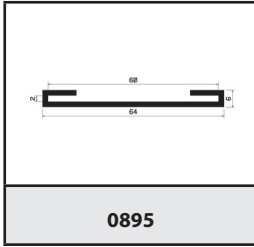

0895

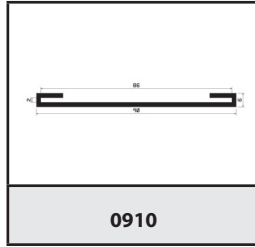

0910

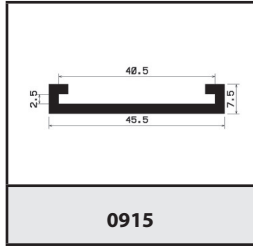

0915

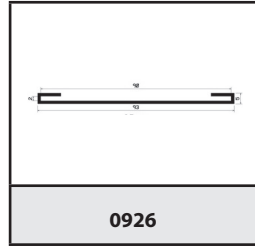

0926

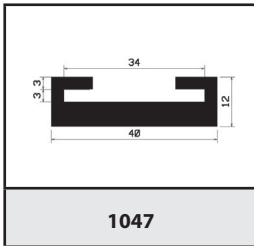

1047

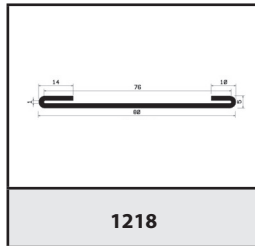

1218

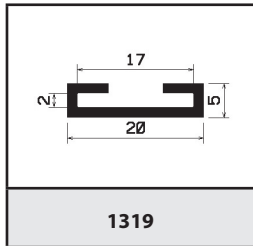

1319

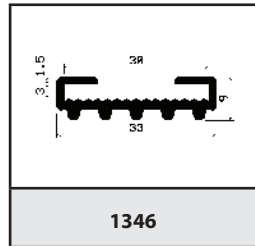

1346

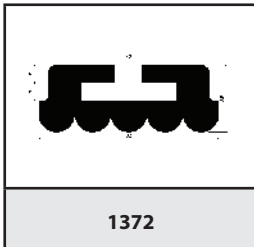

1372

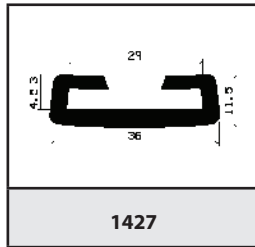

1427

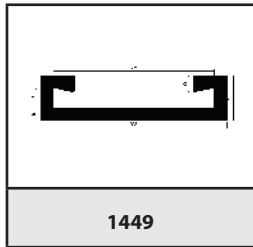

1449

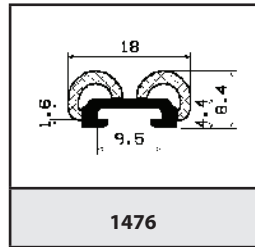

1476

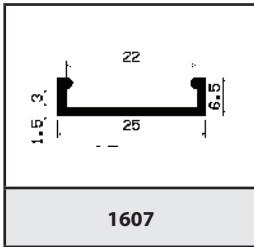

1607

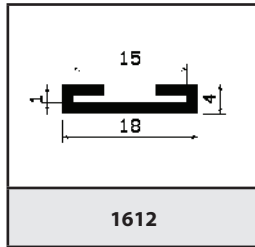

1612

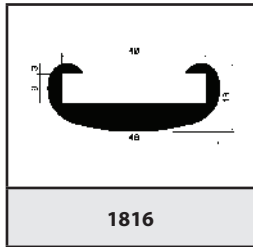

1816

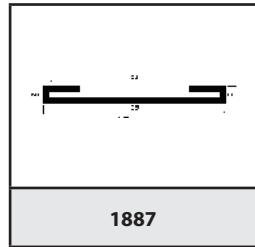

1887

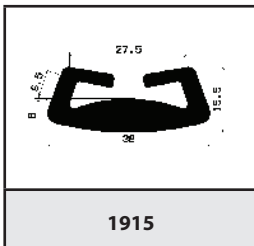

1915

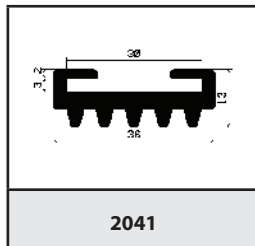

2041

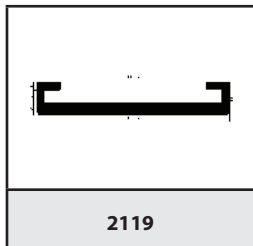

2119

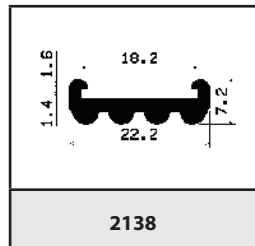

2138

○ foam, foam / silicone

● rubber, silicone

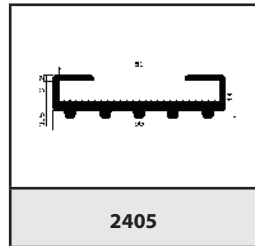
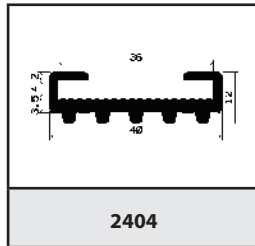
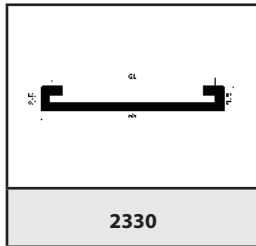
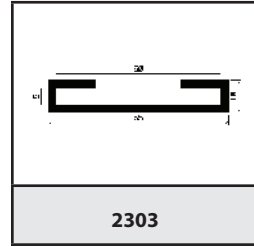
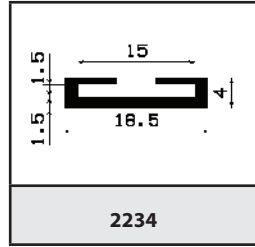
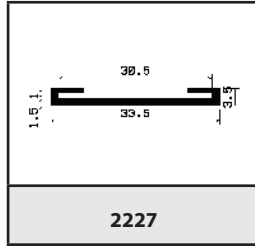
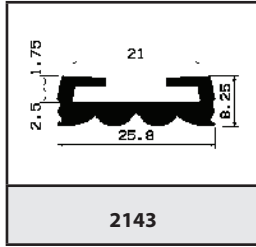
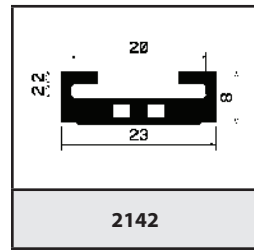
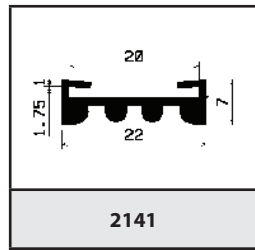
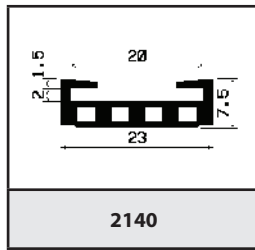
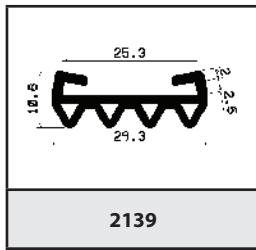

○ foam, foam / silicone

● rubber, silicone

rubber (EPDM, CR, NBR, NR)	foam (EPDM, CR)	silicone		silicone foam
		inner/ outer diameter		
∅ 02,00/05,00mm	∅ 05,00/14,00mm	∅ 01,00/03,00 mm	∅ 10,00/12,00 mm	∅ 06,00/10,00mm
∅ 03,00/05,00mm	∅ 05,90/20,00mm	∅ 02,00/04,00 mm	∅ 10,00/14,00 mm	∅ 07,00/19,00mm
∅ 03,00/06,00mm	∅ 06,00/15,00mm	∅ 03,00/04,00 mm	∅ 10,00/15,00 mm	∅ 12,00/17,00mm
∅ 04,00/06,00mm	∅ 07,80/16,00mm	∅ 03,00/05,00 mm	∅ 10,00/19,00 mm	∅ 12,00/24,00mm
∅ 04,00/07,00mm	∅ 08,00/13,00mm	∅ 03,00/08,00 mm	∅ 10,00/22,00 mm	∅ 13,00/31,00mm
∅ 04,00/07,00mm	∅ 08,00/14,00mm	∅ 03,00/08,50mm	∅ 12,00/16,00 mm	∅ 20,00/34,00mm
∅ 04,00/08,00mm	∅ 08,00/16,00mm	∅ 03,00/09,00 mm	∅ 12,00/20,00 mm	∅ 20,00/40,00mm
∅ 05,00/07,00mm	∅ 08,00/18,00mm	∅ 03,50/04,30mm	∅ 13,00/17,00 mm	∅ 20,00/60,00mm
∅ 05,00/08,00mm	∅ 09,00/19,50mm	∅ 04,00/05,00 mm	∅ 13,00/18,00 mm	∅ 21,00/35,00mm
∅ 05,60/08,00mm	∅ 09,00/28,00mm	∅ 04,00/06,00 mm	∅ 13,00/19,00 mm	∅ 21,00/39,00mm
∅ 06,00/09,00mm	∅ 09,00/30,00mm	∅ 04,00/07,00 mm	∅ 14,00/18,00 mm	∅ 25,00/45,00mm
∅ 06,00/10,00mm	∅ 09,50/13,50m	∅ 04,00/07,20mm	∅ 14,00/22,00 mm	∅ 30,00/50,00mm
∅ 06,00/12,00mm	∅ 09,50/20,00mm	∅ 04,00/08,00 mm	∅ 14,00/44,00 mm	∅ 40,00/60,00mm
∅ 07,00/25,00mm	∅ 10,00/14,00mm	∅ 05,00/08,00 mm	∅ 15,00/19,00 mm	
∅ 08,00/11,00mm	∅ 10,00/15,00mm	∅ 06,00/09,00 mm	∅ 16,00/22,00 mm	
∅ 08,00/12,00mm	∅ 10,00/20,00mm	∅ 06,00/10,00 mm	∅ 17,00/20,00 mm	
∅ 08,00/15,00mm	∅ 10,00/25,00mm	∅ 06,00/12,00 mm	∅ 18,00/22,00 mm	
∅ 09,00/12,00mm	∅ 10,00/32,00mm	∅ 06,00/25,00 mm	∅ 20,00/60,00mm	
∅ 10,00/14,00mm	∅ 12,00/26,00mm	∅ 07,00/08,00 mm	∅ 24,00/28,00 mm	
∅ 10,00/32,00mm	∅ 12,00/28,00mm	∅ 07,00/10,00 mm	∅ 25,00/31,00 mm	
∅ 12,00/02,20mm	∅ 12,00/30,00mm	∅ 08,00/10,00 mm	∅ 25,00/52,00 mm	
∅ 12,00/15,00mm	∅ 14,00/20,00mm	∅ 08,00/12,00 mm	∅ 26,00/30,00 mm	
∅ 12,00/16,00mm	∅ 14,00/24,00mm	∅ 08,00/14,00 mm	∅ 30,00/44,00 mm	
∅ 12,00/17,00mm	∅ 15,00/25,00mm	∅ 09,00/13,00 mm	∅ 40,00/43,00 mm	
∅ 14,00/26,00mm	∅ 15,00/35,00mm	∅ 50,00/56,00 mm	∅ 40,00/46,00 mm	
∅ 16,00/19,00mm	∅ 15,00/36,00mm	∅ 55,00/60,00 mm	∅ 40,00/50,00 mm	
∅ 20,00/23,00mm	∅ 16,00/25,00mm	∅ 80,00/84,00 mm	∅ 44,00/54,00 mm	
∅ 20,00/24,00mm	∅ 16,00/26,00mm			
∅ 22,00/27,00mm	∅ 16,00/30,00mm			
∅ 24,00/28,00mm	∅ 16,00/36,00mm			
∅ 28,00/32,00mm	∅ 18,00/25,00mm			
∅ 28,00/40,00mm	∅ 18,00/26,00mm			
	∅ 18,00/35,00mm			
	∅ 19,00/25,00mm			
	∅ 19,00/30,00mm			
	∅ 20,00/50,00mm			
	∅ 22,00/30,00mm			
	∅ 22,00/48,00mm			
	∅ 23,00/34,00mm			
	∅ 28,00/46,00mm			

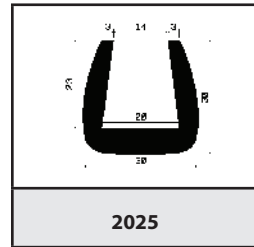
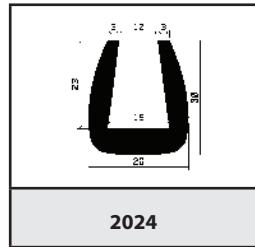
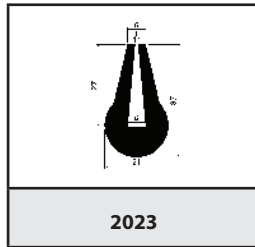
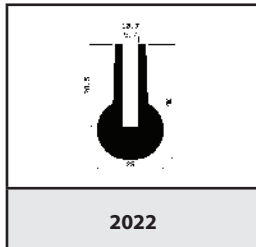
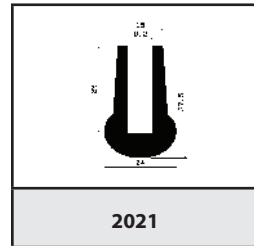
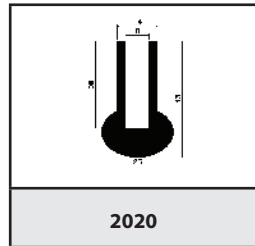
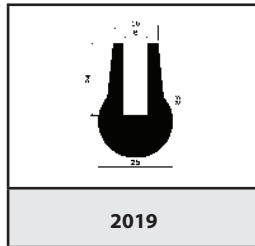
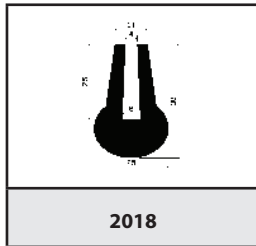
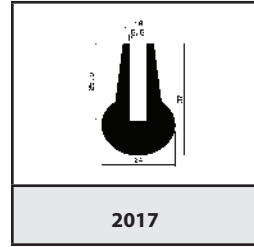
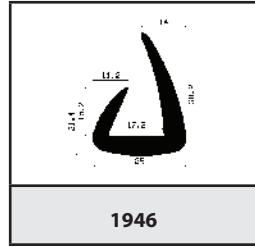
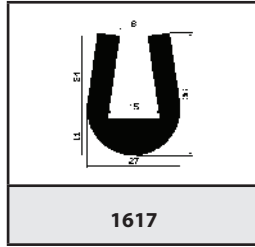
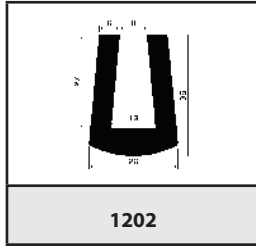
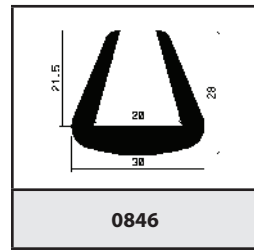
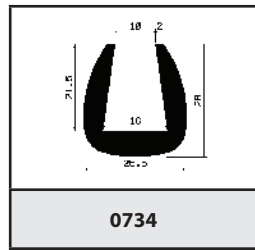
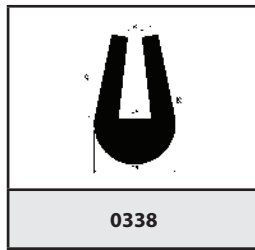
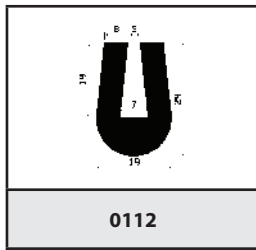

○ foam, foam / silicone

● rubber, silicone

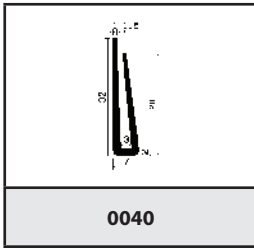

0040

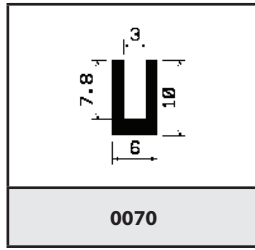

0070

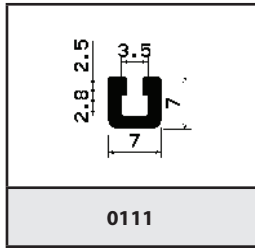

0111

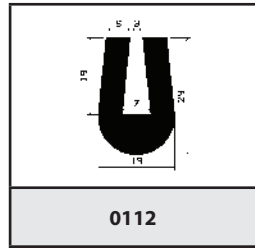

0112

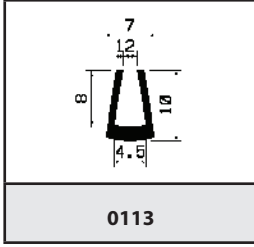

0113

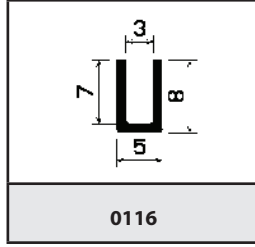

0116

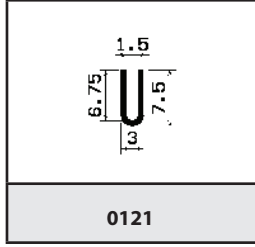

0121

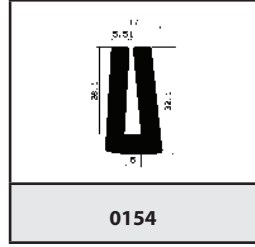

0154

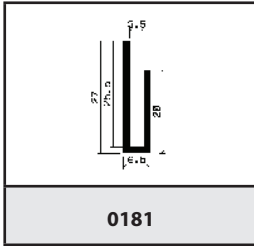

0181

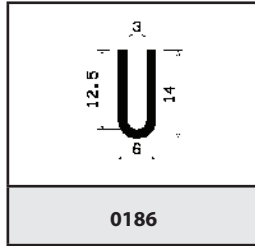

0186

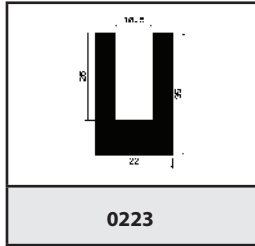

0223

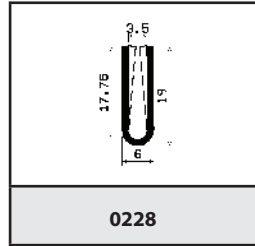

0228

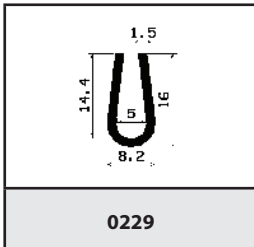

0229

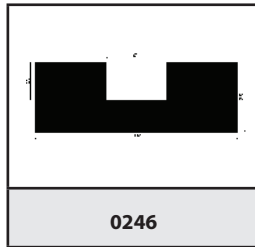

0246

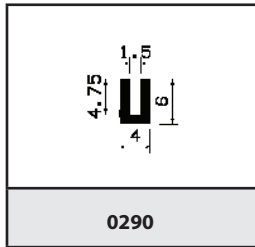

0290

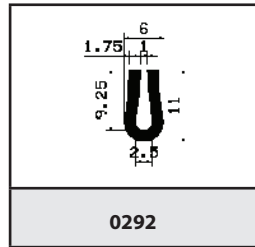

0292

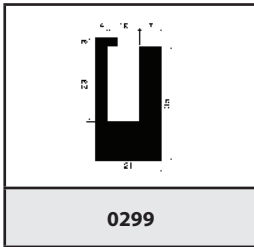

0299

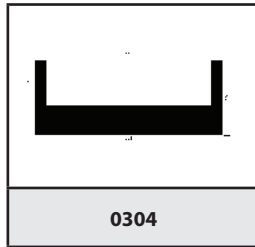

0304

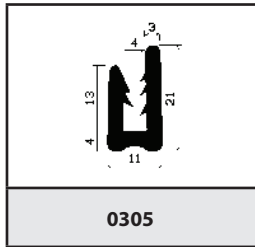

0305

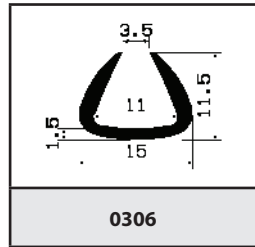

0306

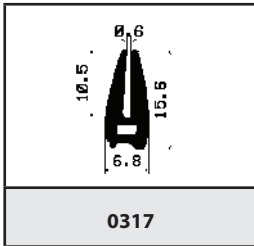

0317

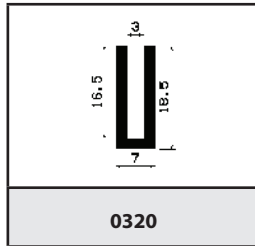

0320

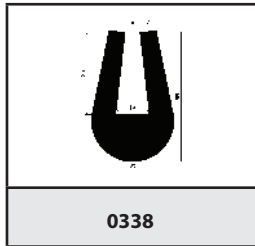

0338

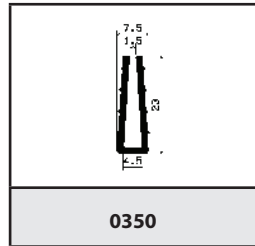

0350

○ foam, foam / silicone

● rubber, silicone

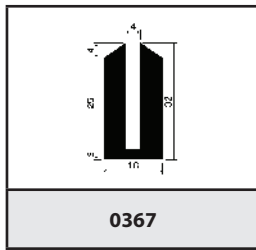

0367

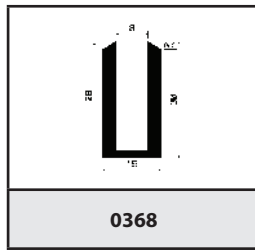

0368

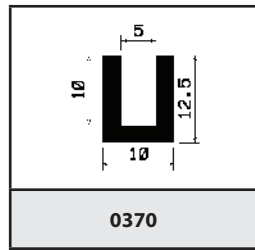

0370

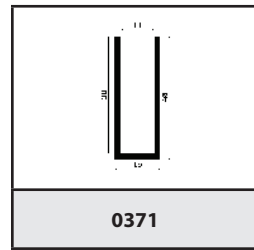

0371

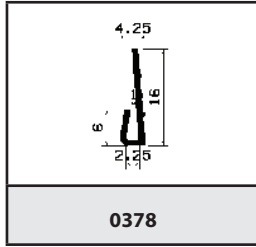

0378

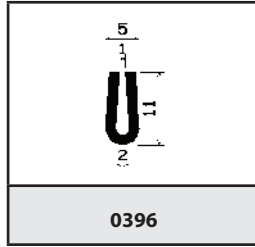

0396

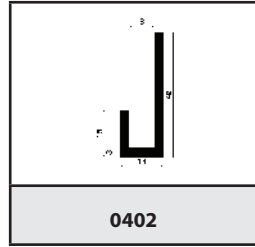

0402

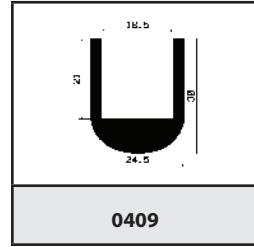

0409

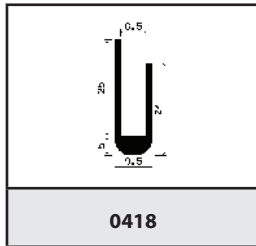

0418

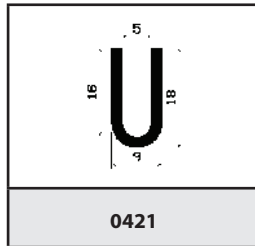

0421

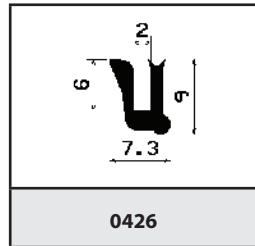

0426

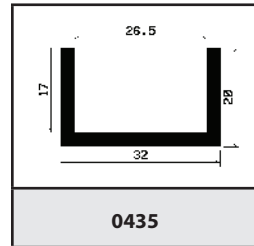

0435

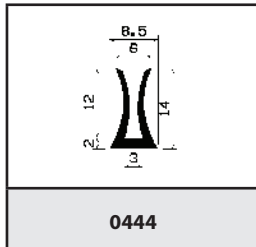

0444

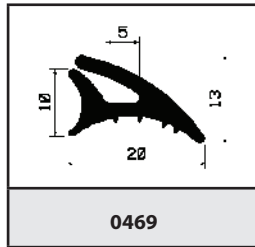

0469

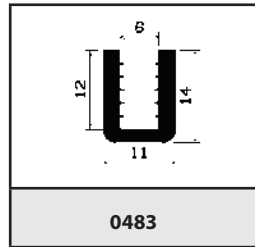

0483

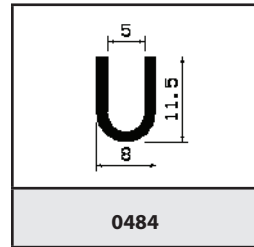

0484

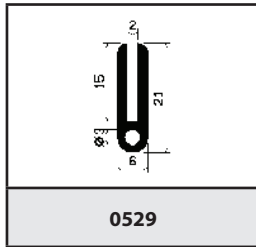

0529

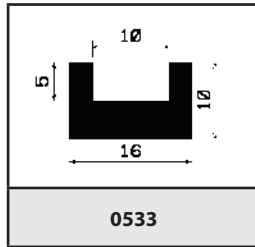

0533

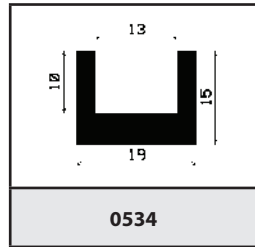

0534

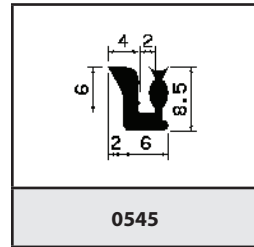

0545

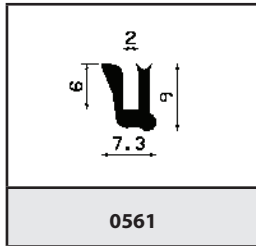

0561

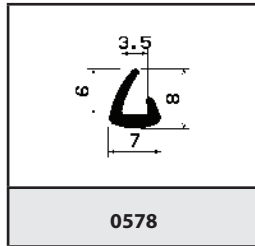

0578

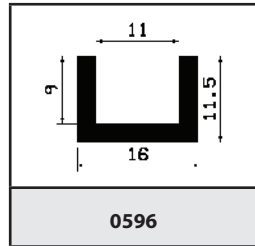

0596

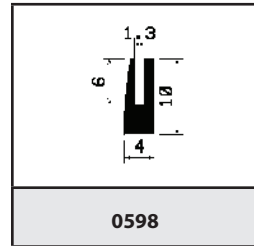

0598



foam, foam / silicone



rubber, silicone

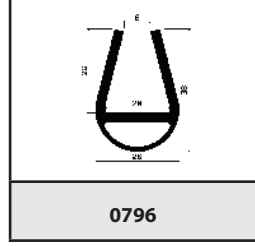
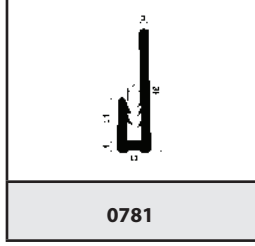
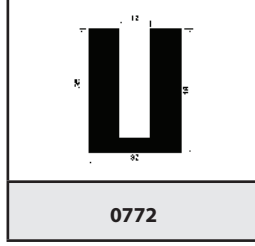
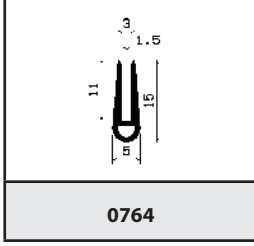
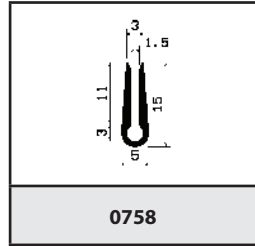
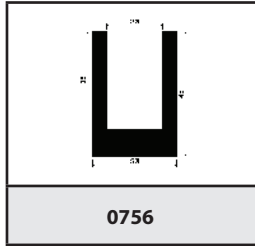
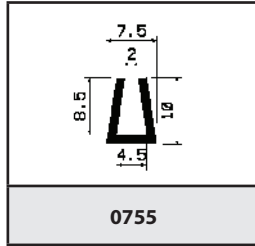
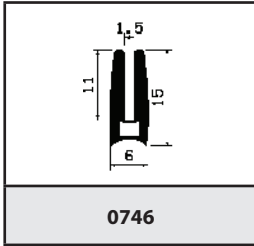
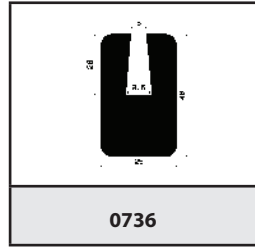
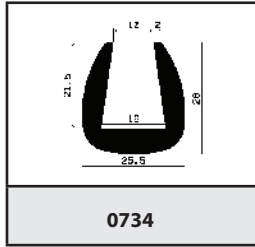
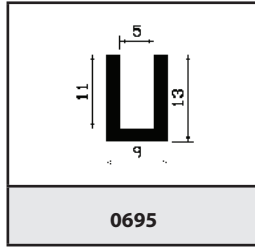
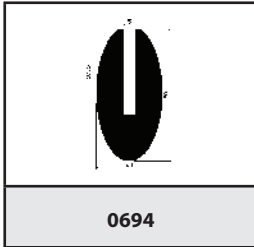
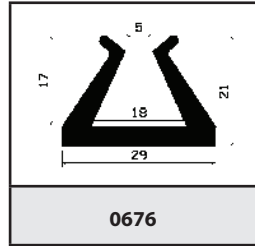
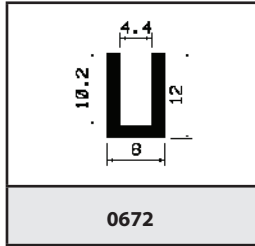
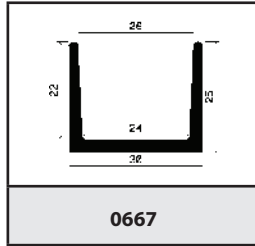
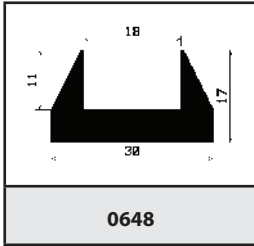
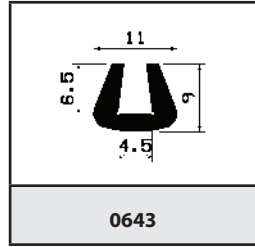
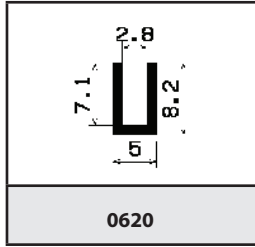
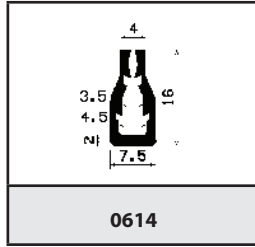
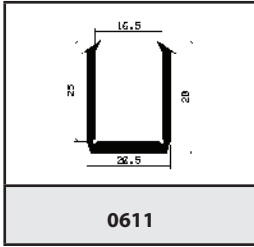
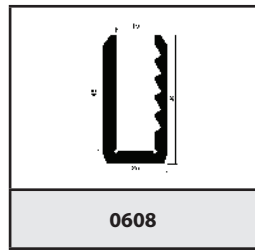
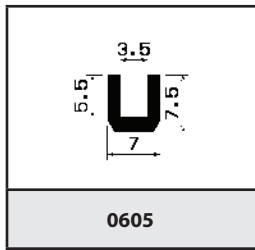
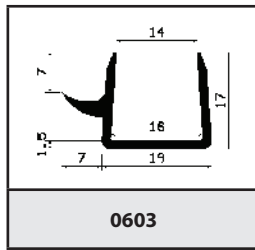
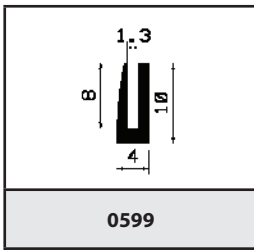

○ foam, foam / silicone

● rubber, silicone

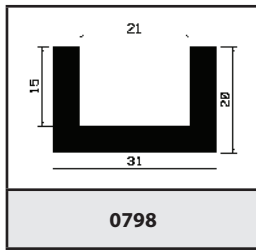

0798

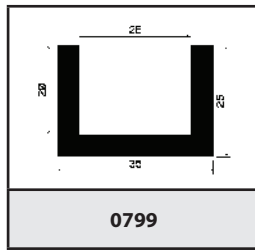

0799

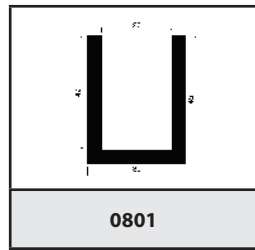

0801

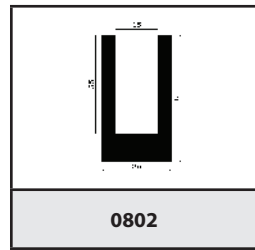

0802

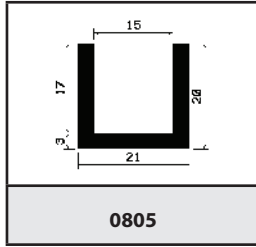

0805

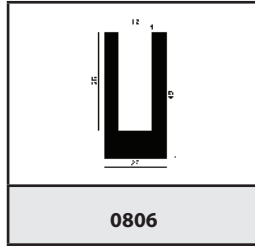

0806

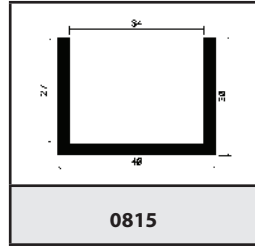

0815

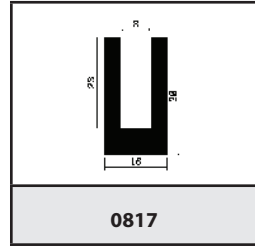

0817

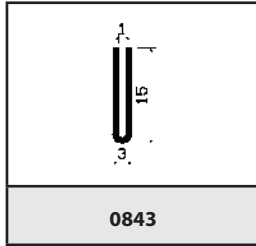

0843

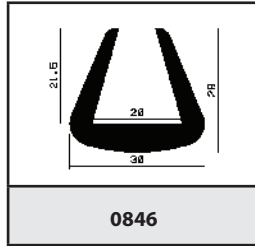

0846

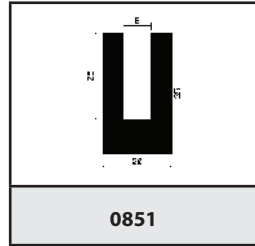

0851

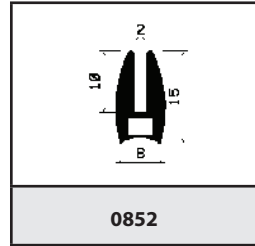

0852

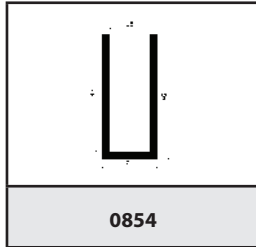

0854

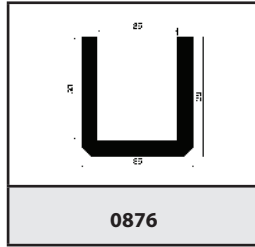

0876

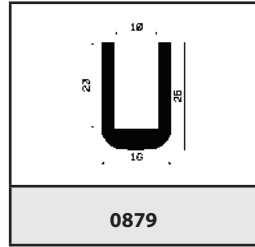

0879

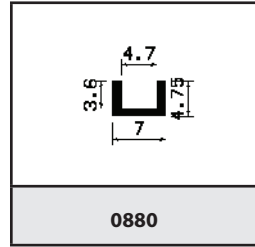

0880

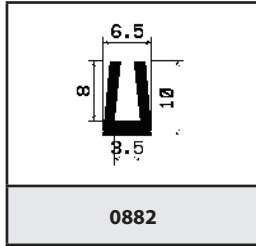

0882

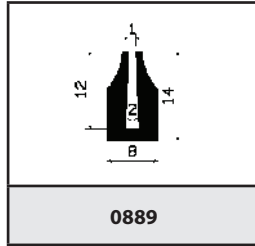

0889

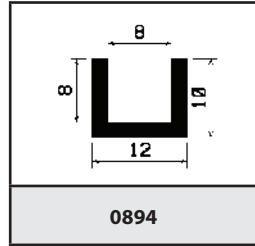

0894

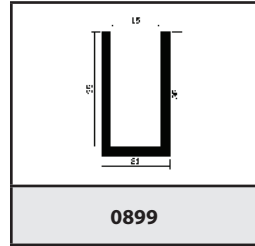

0899

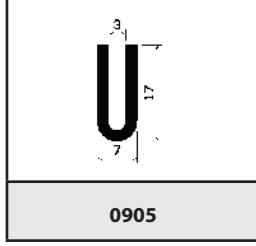

0905

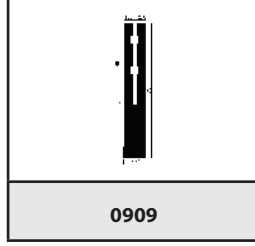

0909

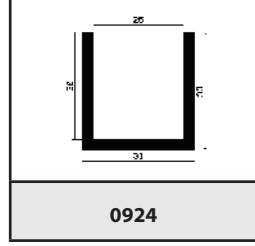

0924

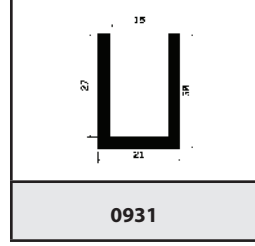

0931

○ foam, foam / silicone

● rubber, silicone

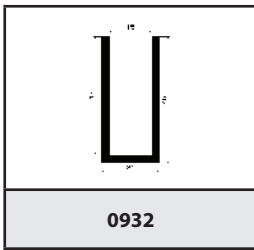

0932

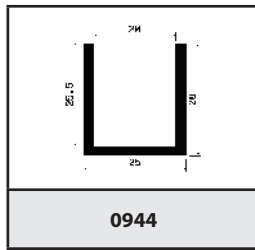

0944

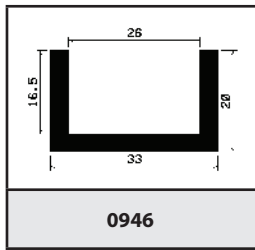

0946

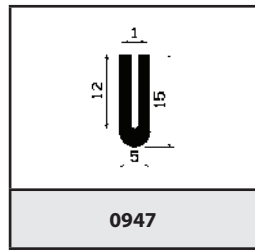

0947

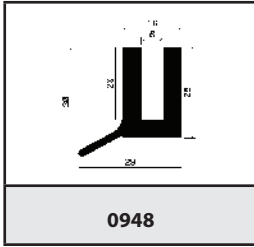

0948

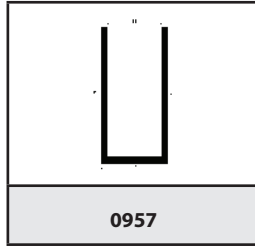

0957

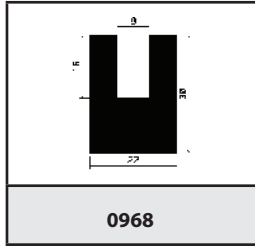

0968

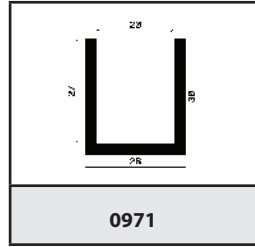

0971

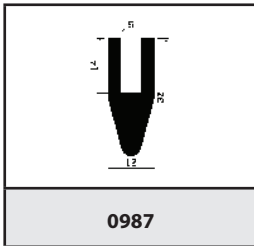

0987

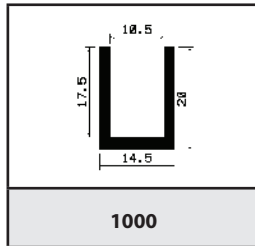

1000

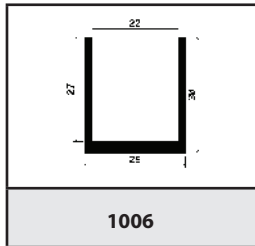

1006

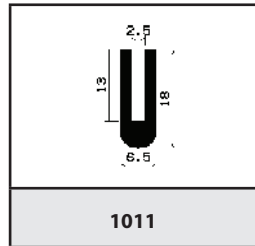

1011

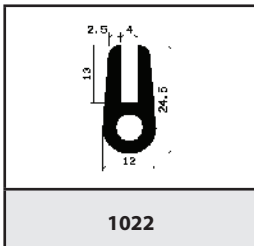

1022

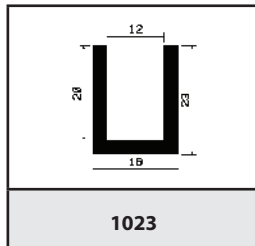

1023

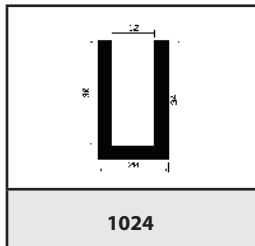

1024

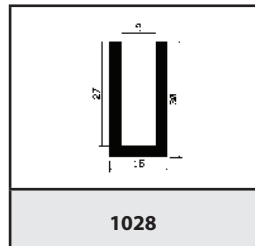

1028

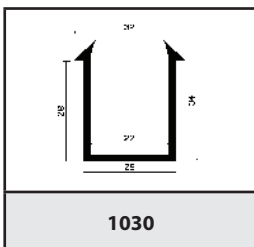

1030

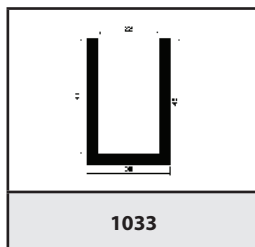

1033

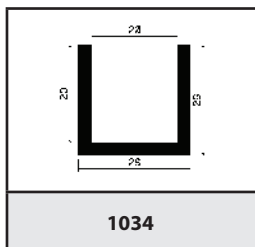

1034

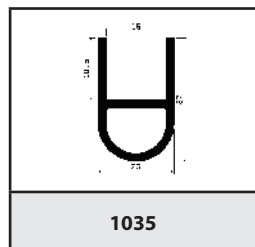

1035

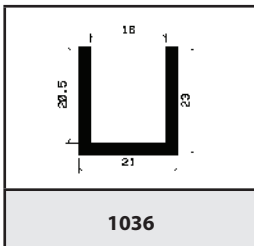

1036

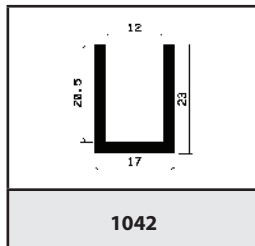

1042

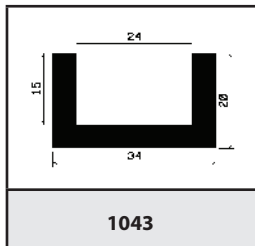

1043

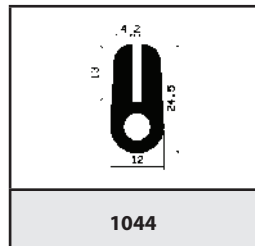

1044

○ foam, foam / silicone

● rubber, silicone

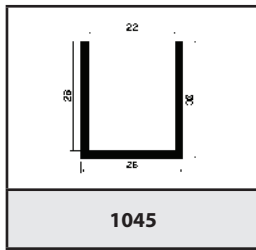

1045

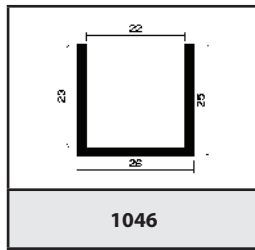

1046

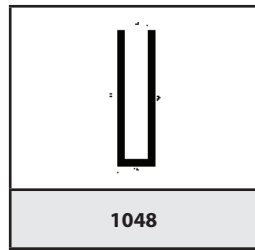

1048

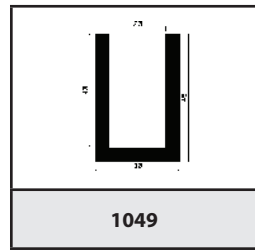

1049

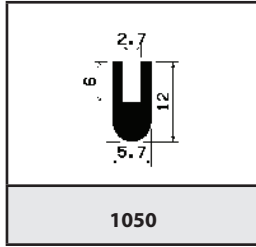

1050

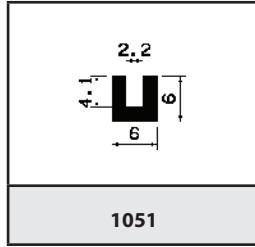

1051

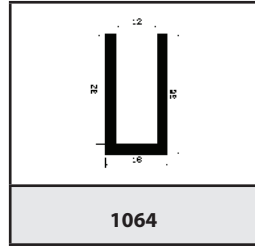

1064

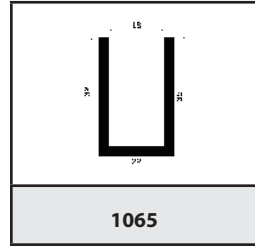

1065

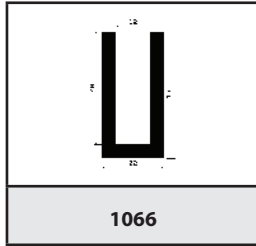

1066

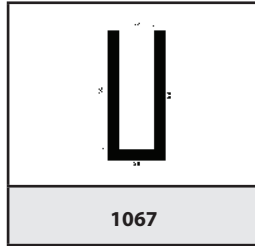

1067

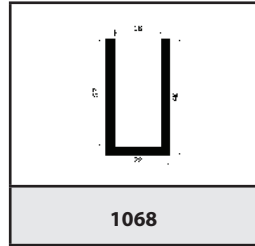

1068

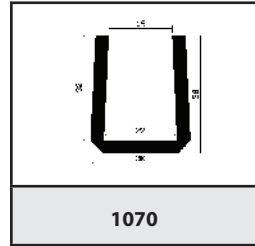

1070

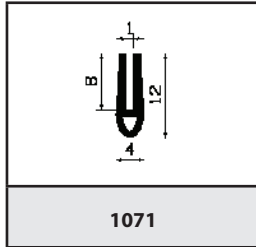

1071

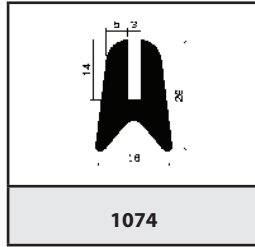

1074

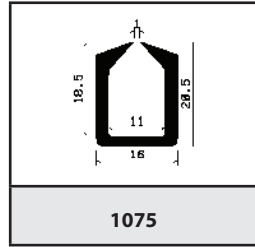

1075

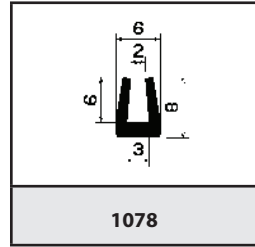

1078

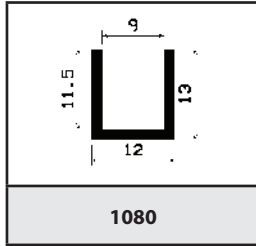

1080

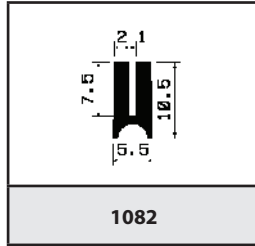

1082

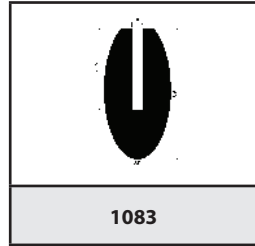

1083

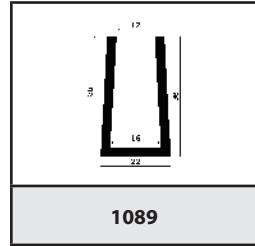

1089

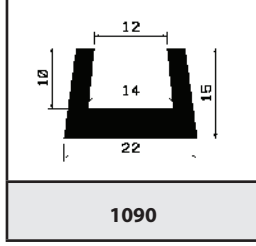

1090

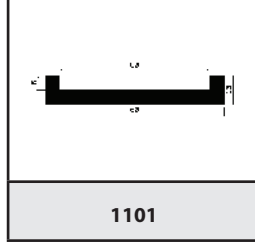

1101

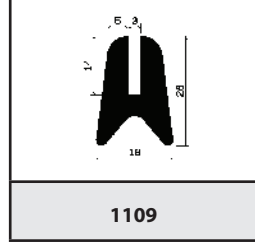

1109

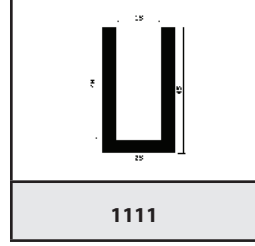

1111

○ foam, foam / silicone ● rubber, silicone

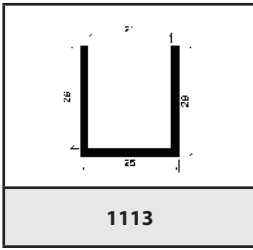

1113

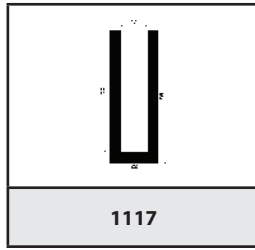

1117

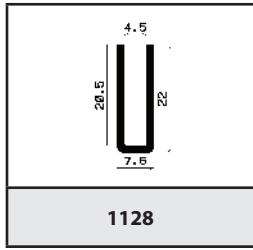

1128

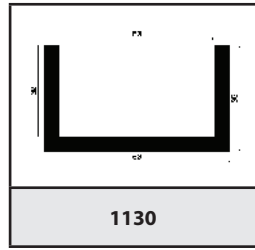

1130

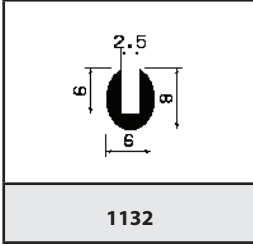

1132

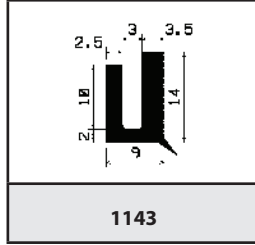

1143

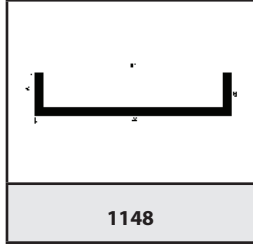

1148

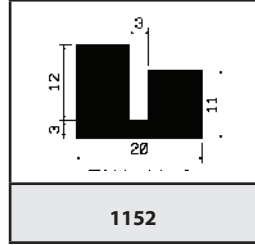

1152

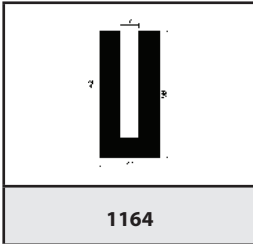

1164

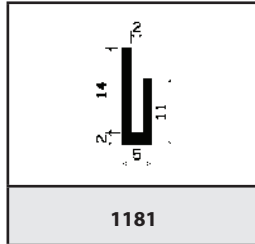

1181

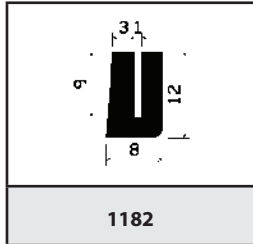

1182

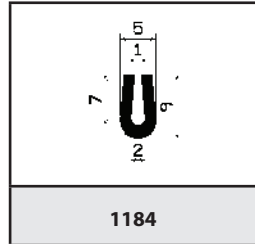

1184

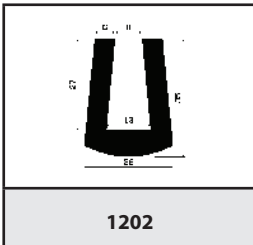

1202

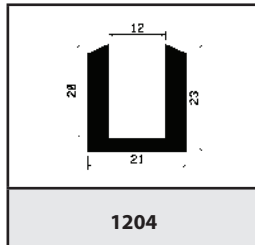

1204

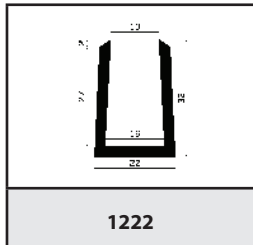

1222

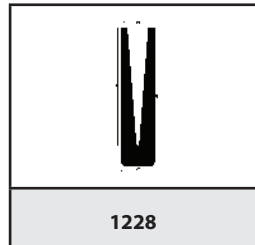

1228

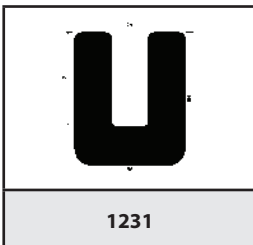

1231

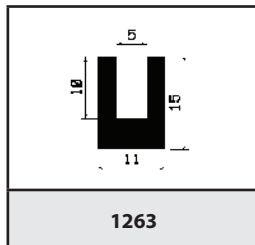

1263

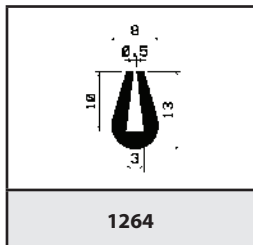

1264

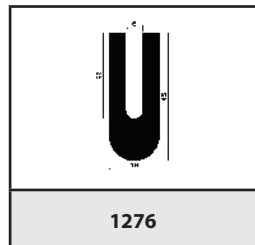

1276

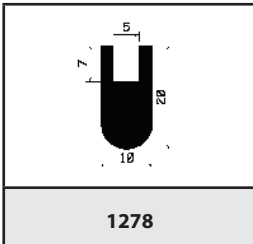

1278

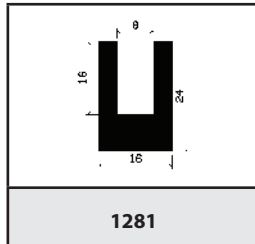

1281

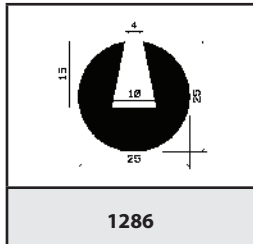

1286

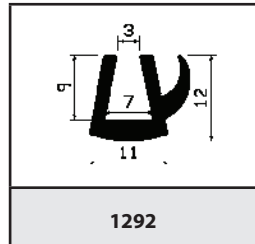

1292

○ foam, foam / silicone

● rubber, silicone

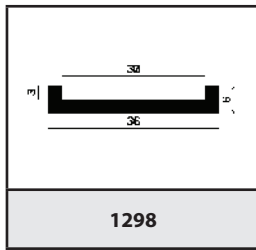

1298

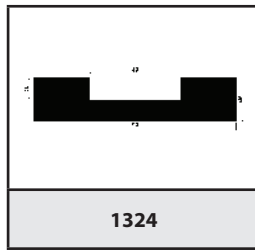

1324

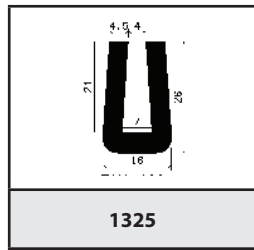

1325

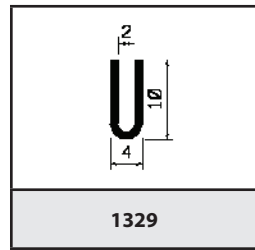

1329

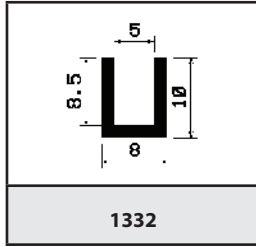

1332

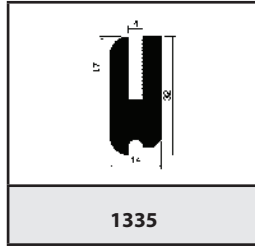

1335

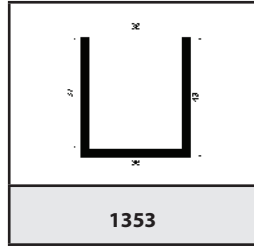

1353

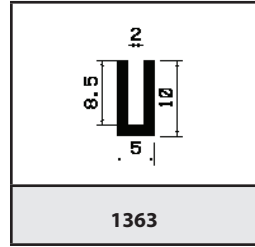

1363

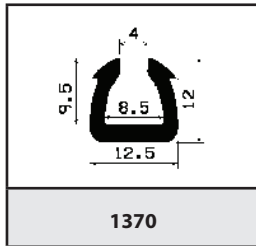

1370

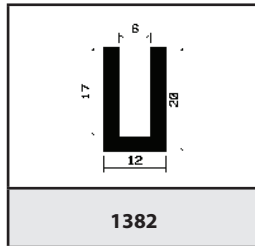

1382

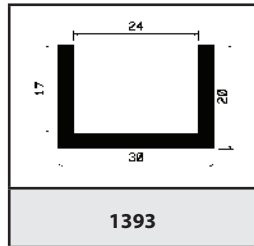

1393

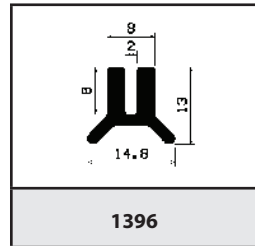

1396

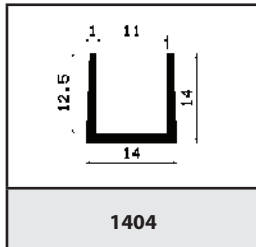

1404

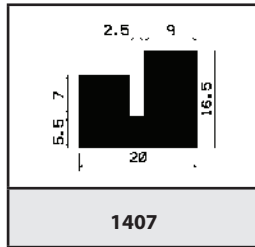

1407

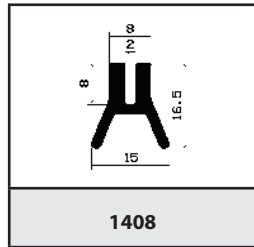

1408

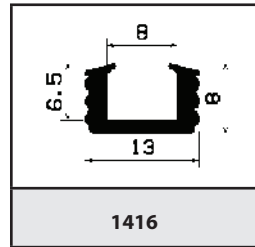

1416

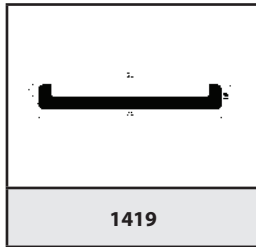

1419

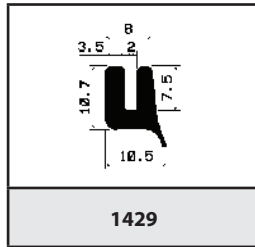

1429

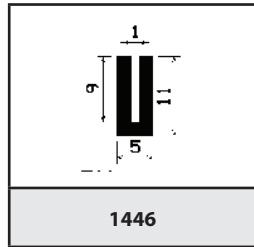

1446

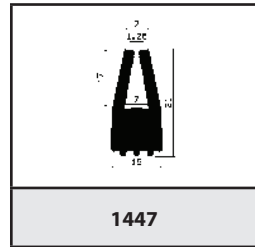

1447

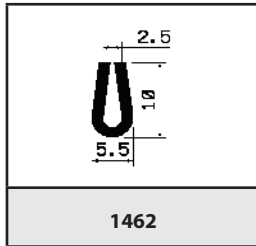

1462

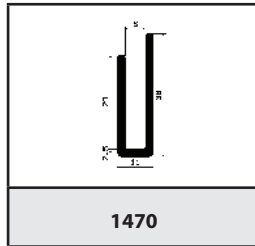

1470

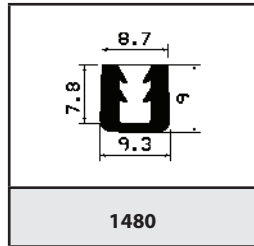

1480

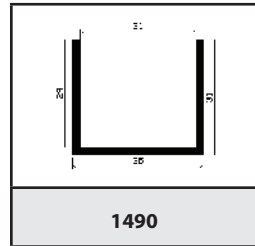

1490



foam, foam / silicone



rubber, silicone

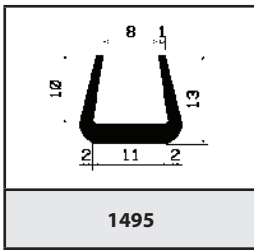

1495

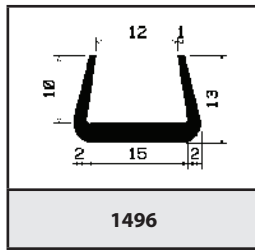

1496

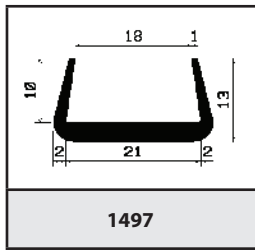

1497

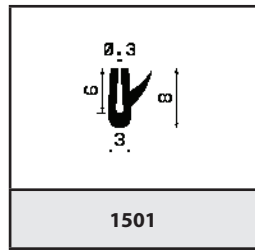

1501

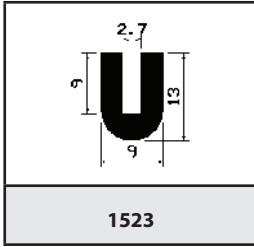

1523

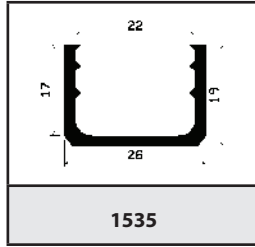

1535

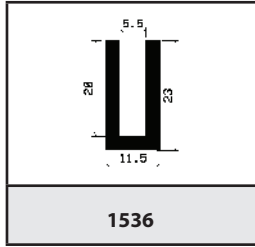

1536

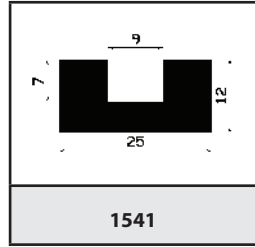

1541

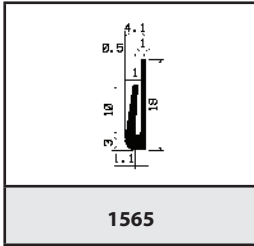

1565

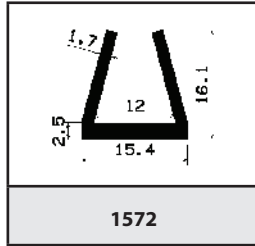

1572

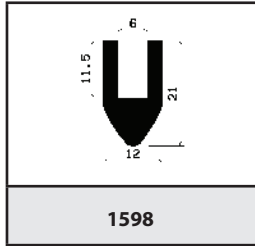

1598

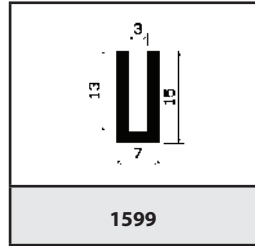

1599

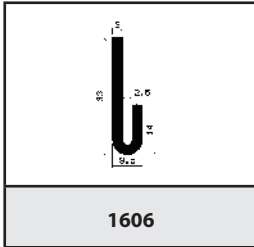

1606

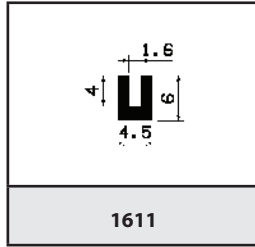

1611

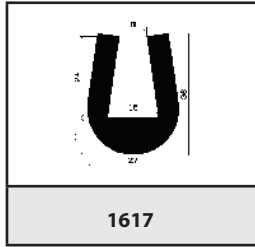

1617

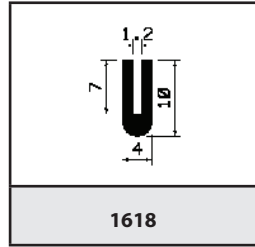

1618

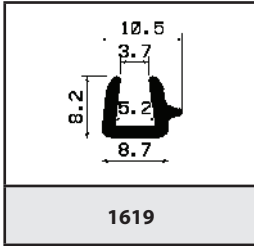

1619

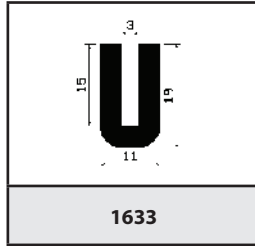

1633

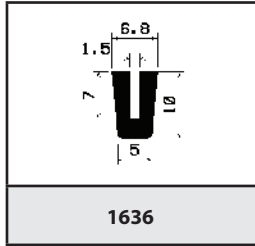

1636

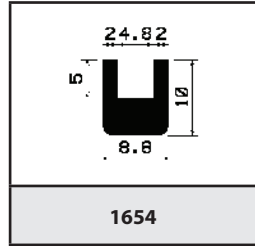

1654

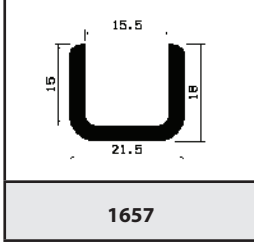

1657

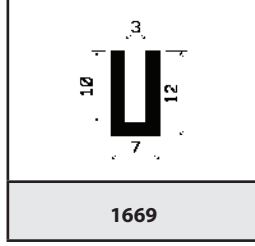

1669

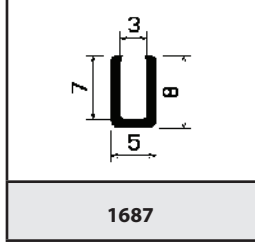

1687

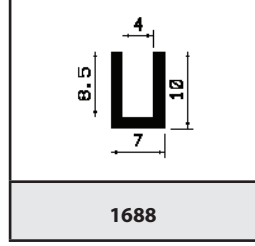

1688

○ foam, foam / silicone

● rubber, silicone

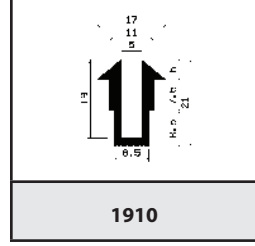
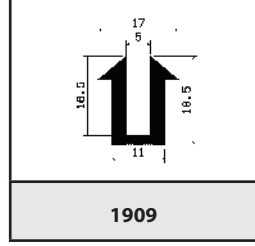
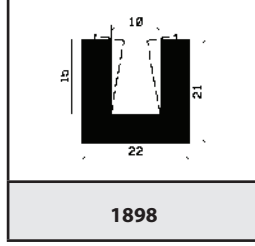
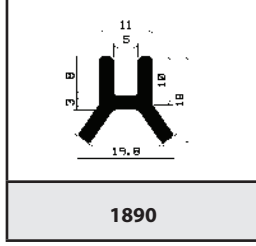
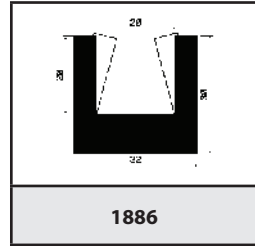
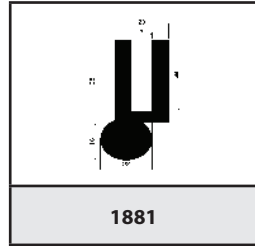
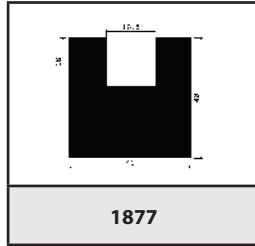
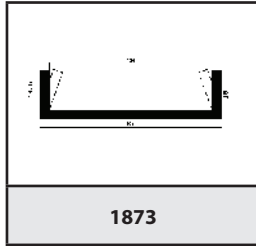
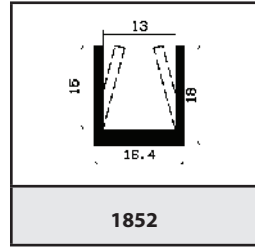
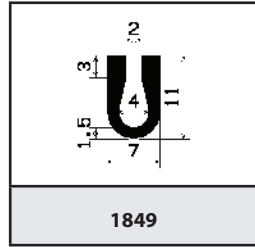
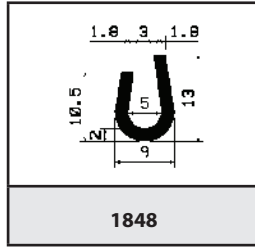
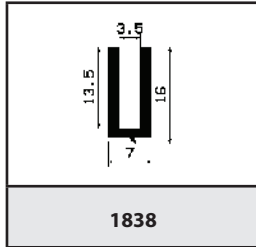
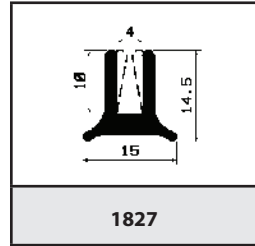
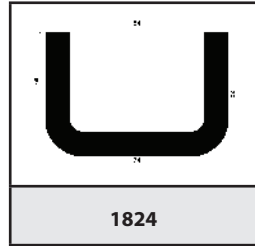
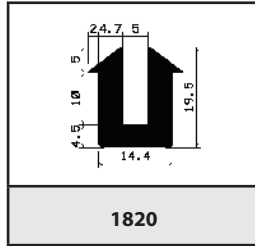
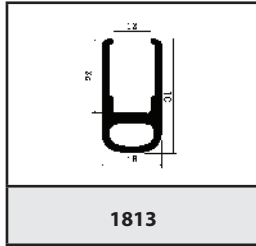
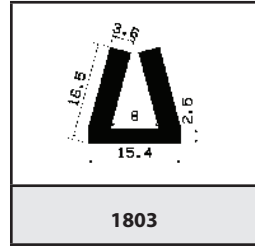
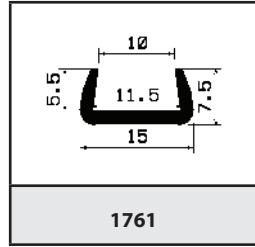
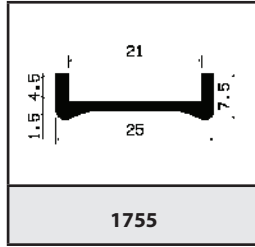
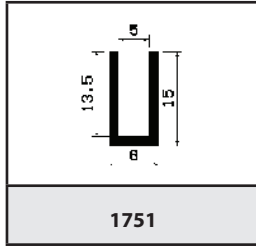
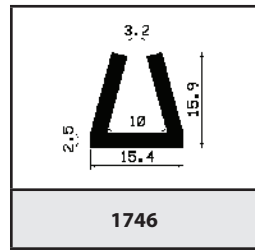
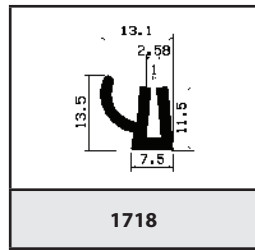
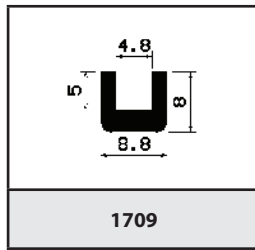
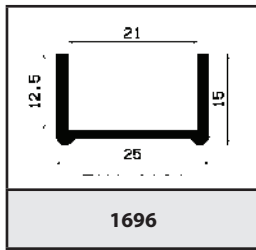

foam, foam / silicone



rubber, silicone

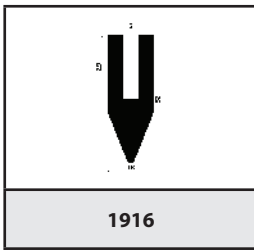

1916

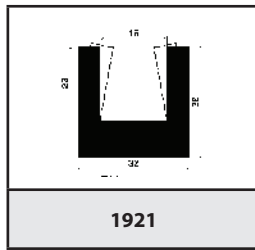

1921

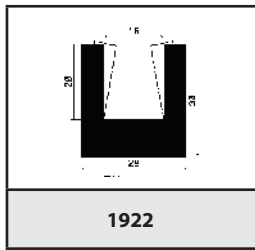

1922

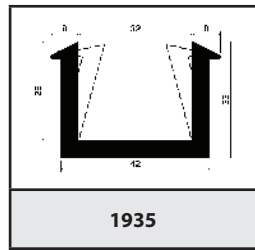

1935

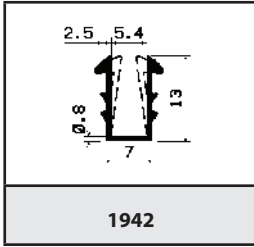

1942

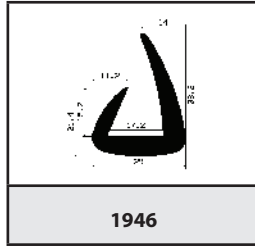

1946

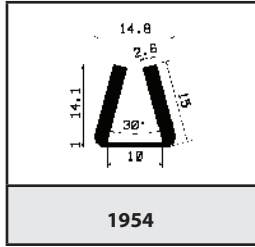

1954

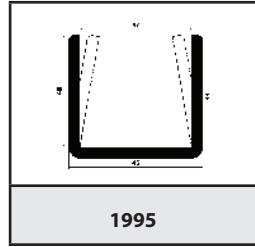

1995

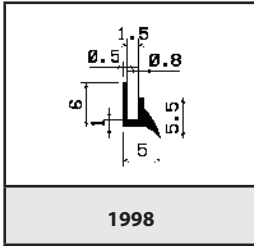

1998

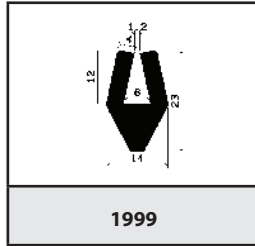

1999

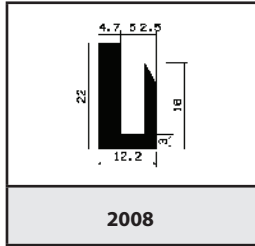

2008

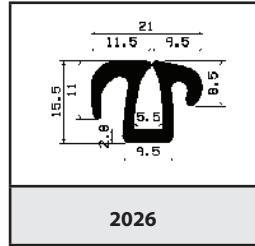

2026

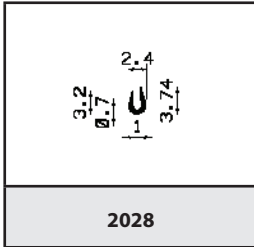

2028

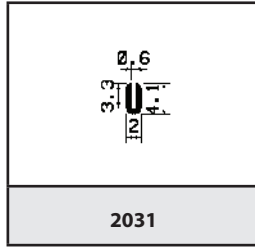

2031

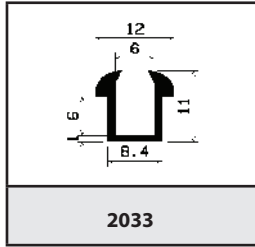

2033

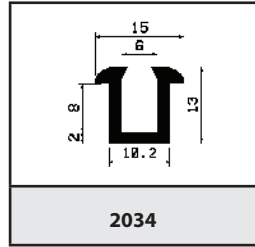

2034

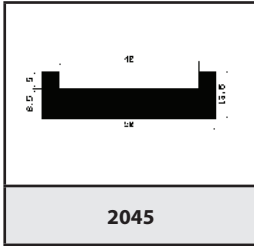

2045

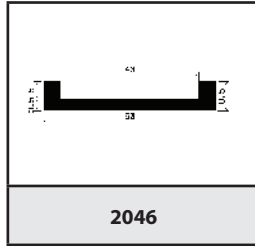

2046

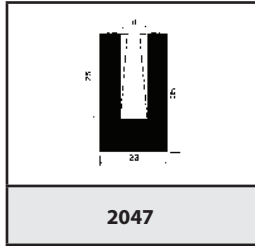

2047

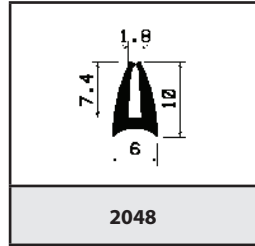

2048

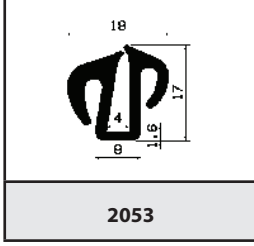

2053

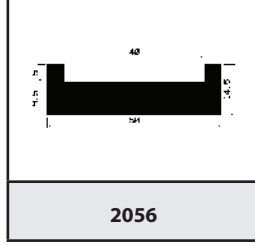

2056

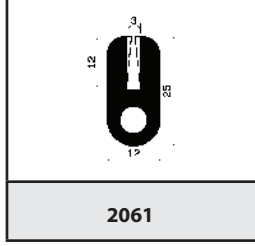

2061

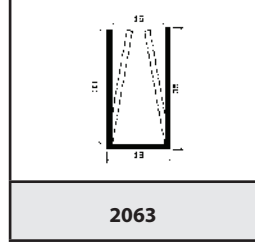

2063

○ foam, foam / silicone

● rubber, silicone

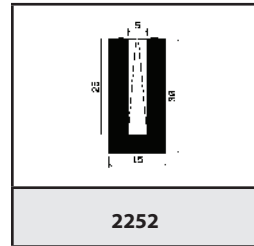
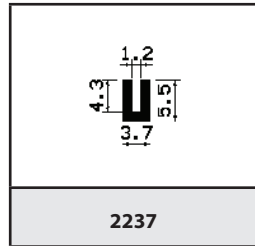
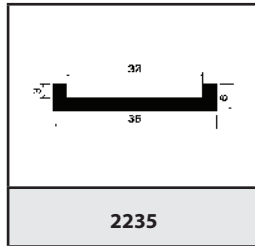
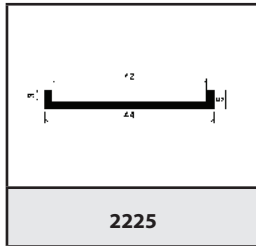
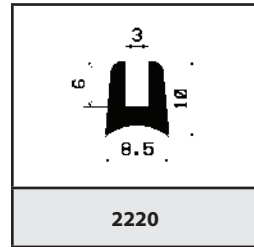
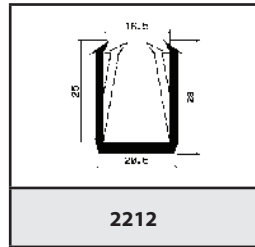
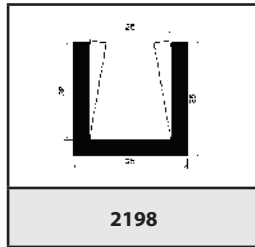
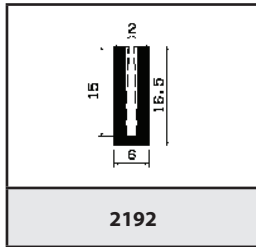
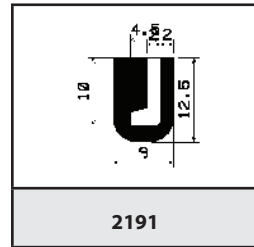
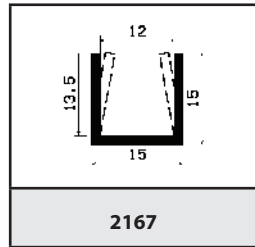
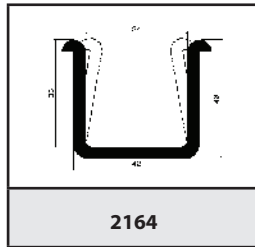
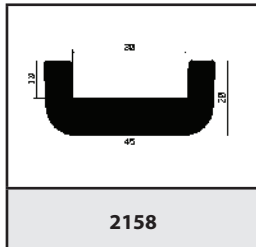
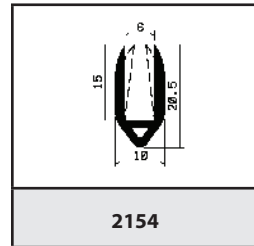
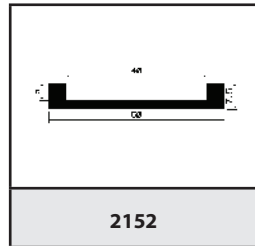
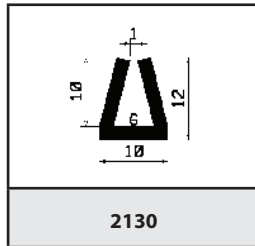
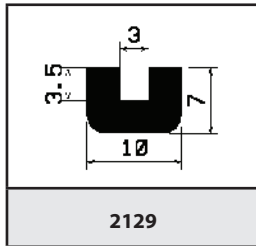
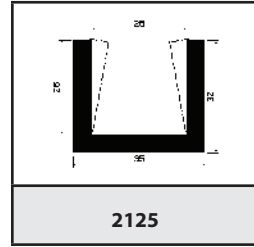
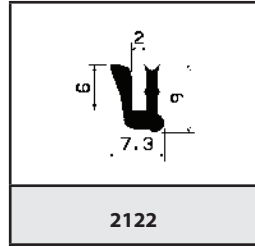
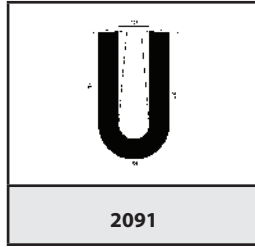
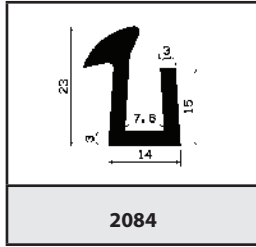
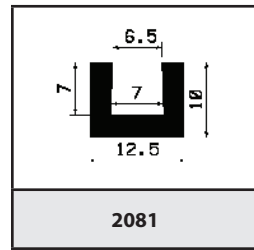
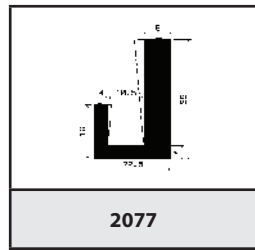
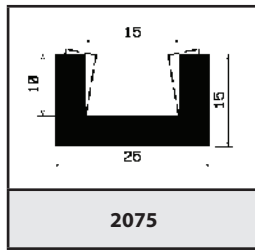
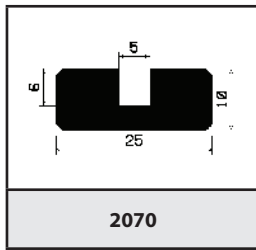

○ foam, foam / silicone ● rubber, silicone

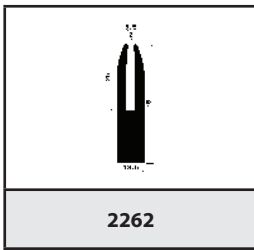

2262

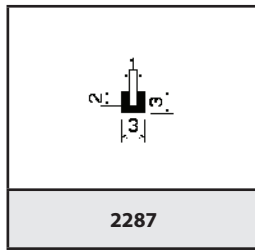

2287

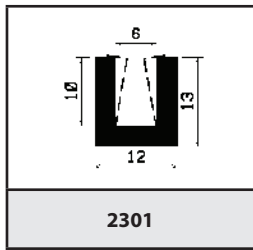

2301

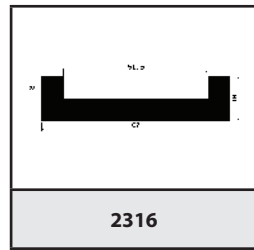

2316

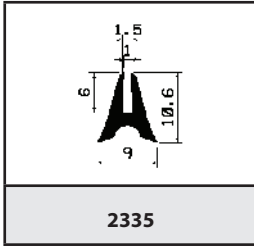

2335

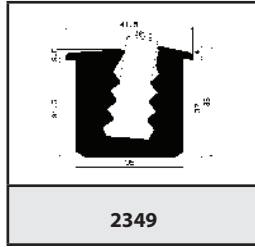

2349

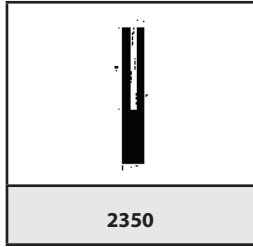

2350

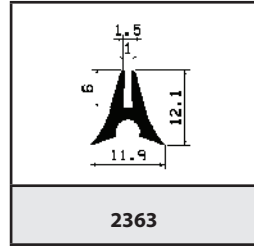

2363

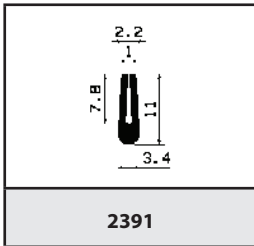

2391

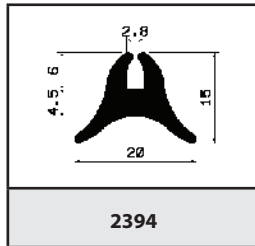

2394

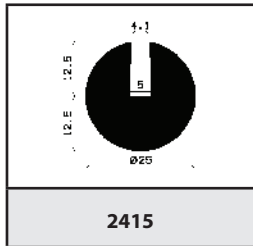

2415

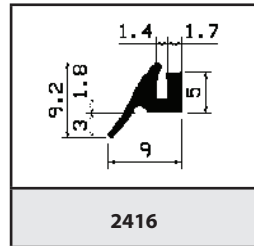

2416

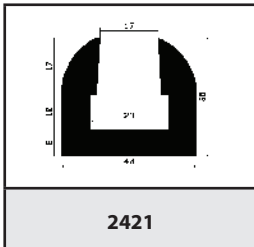

2421

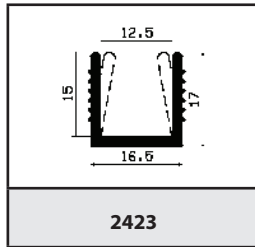

2423

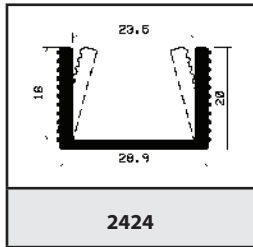

2424

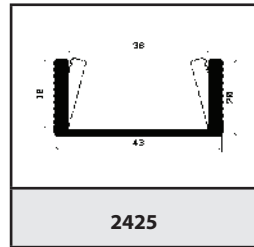

2425

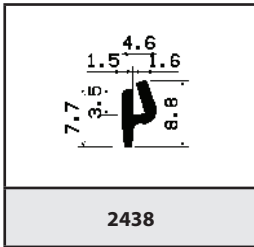

2438

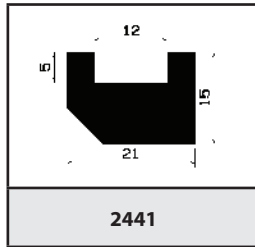

2441

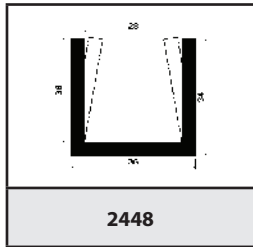

2448

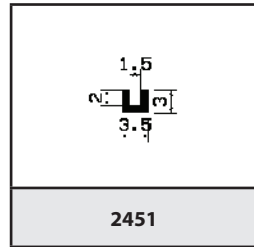

2451

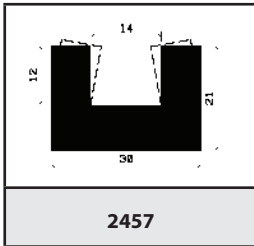

2457

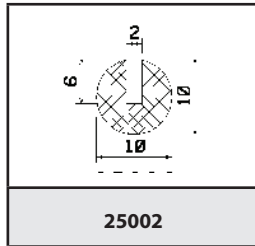

25002

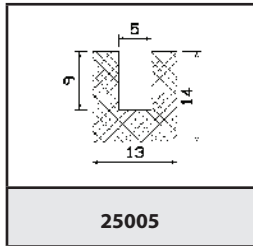

25005

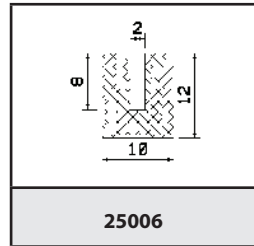

25006

○ foam, foam / silicone

● rubber, silicone

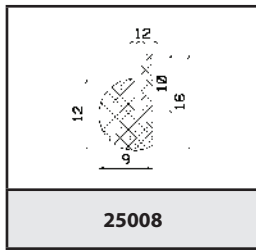

25008

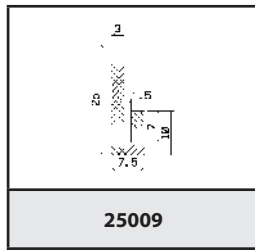

25009

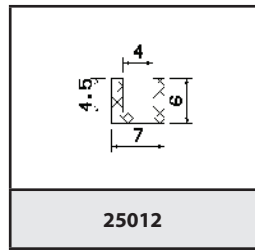

25012

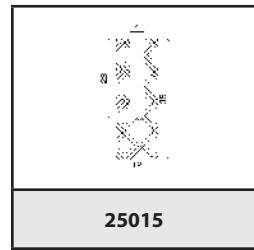

25015

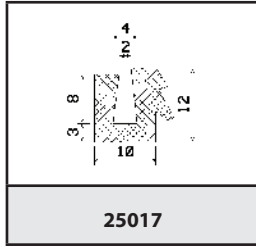

25017

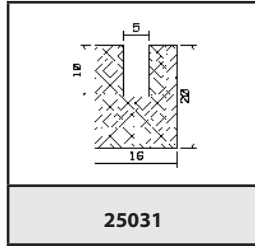

25031

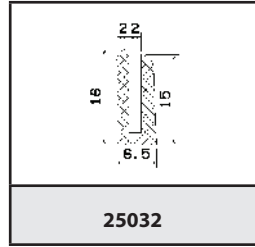

25032

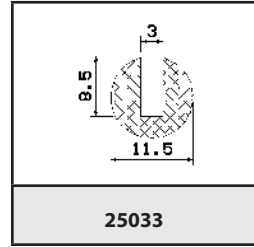

25033

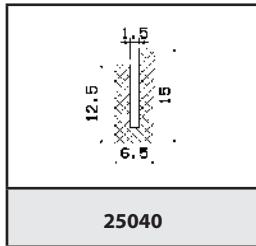

25040

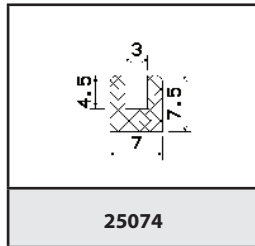

25074

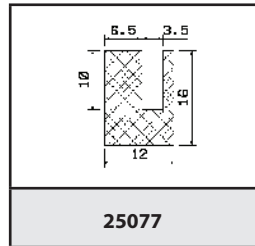

25077

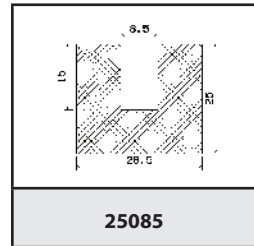

25085

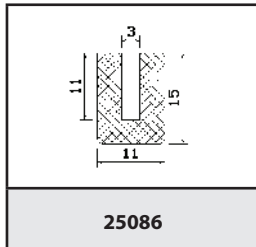

25086

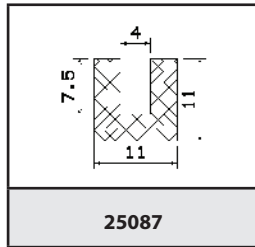

25087

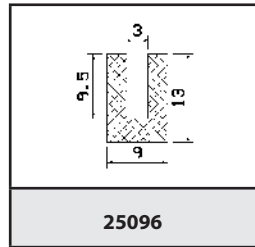

25096

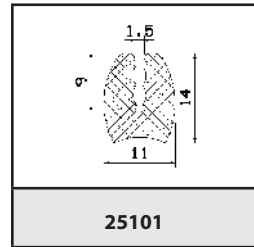

25101

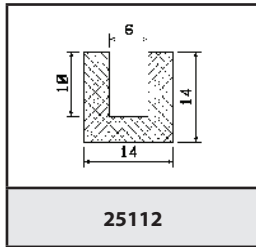

25112

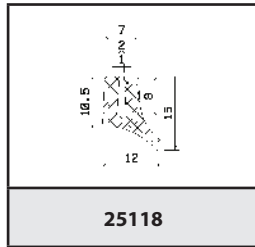

25118

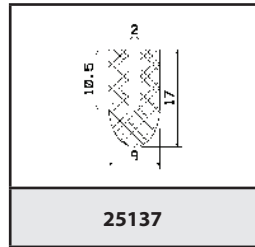

25137

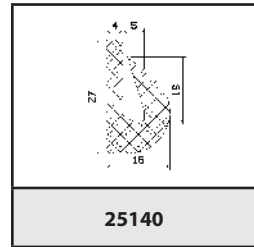

25140

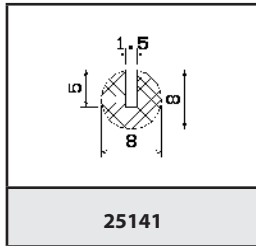

25141

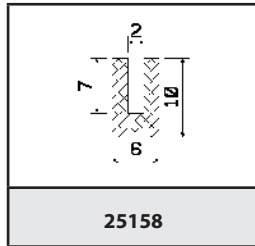

25158

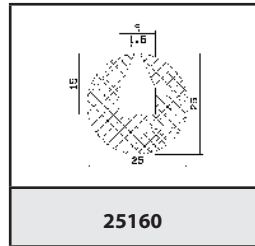

25160

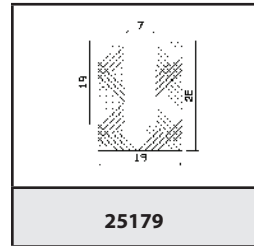

25179



foam, foam / silicone



rubber, silicone

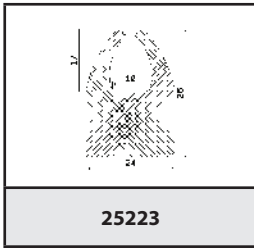

25223

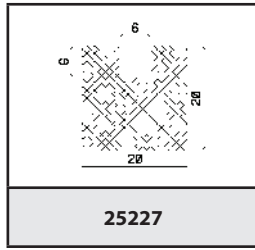

25227

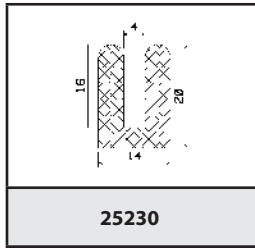

25230

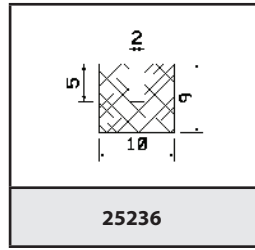

25236

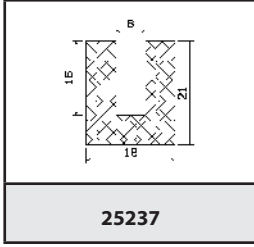

25237

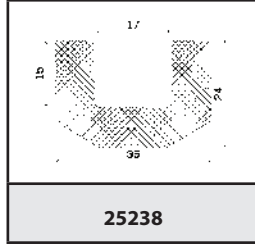

25238

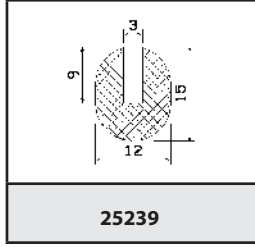

25239

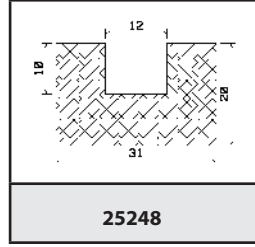

25248

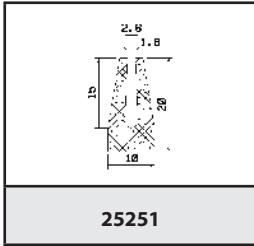

25251

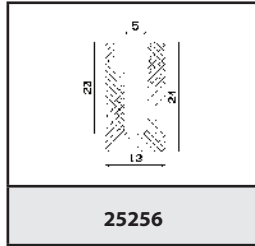

25256

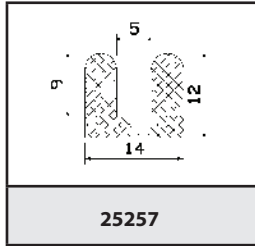

25257

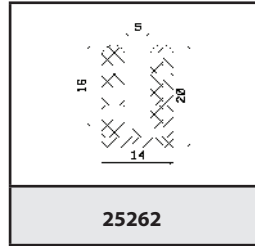

25262

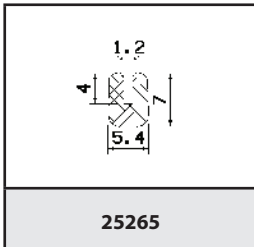

25265

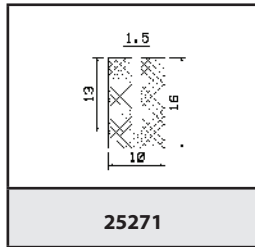

25271

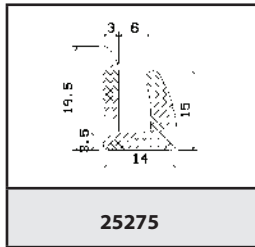

25275

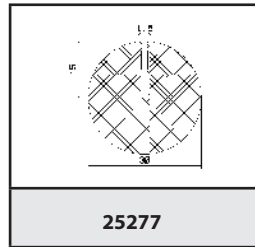

25277

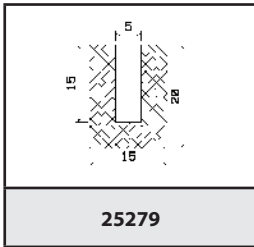

25279

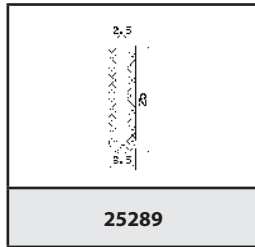

25289

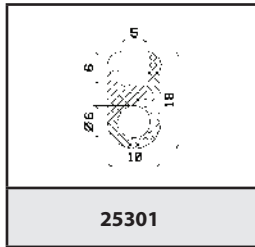

25301

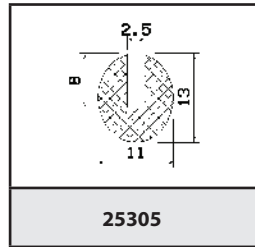

25305

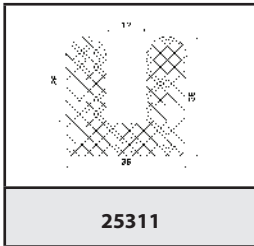

25311

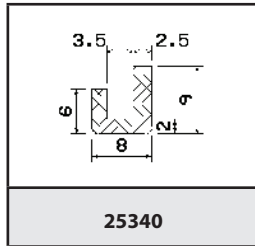

25340

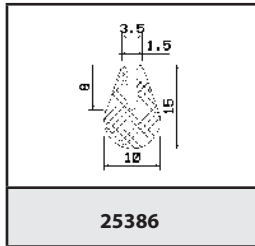

25386

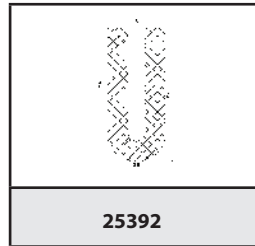

25392

○ foam, foam / silicone

● rubber, silicone

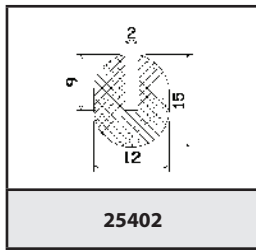

25402

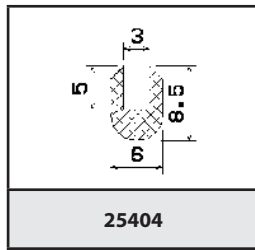

25404

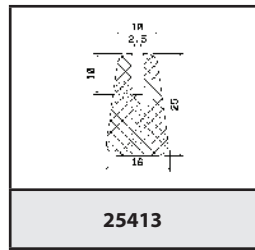

25413

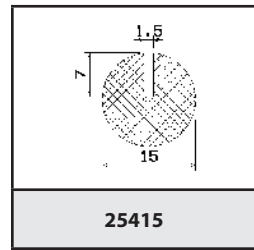

25415

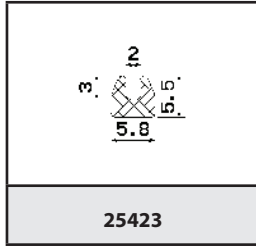

25423

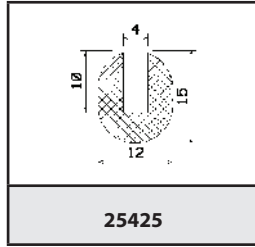

25425

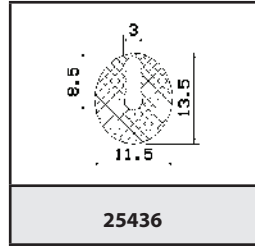

25436

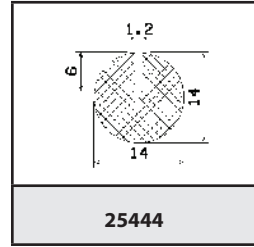

25444

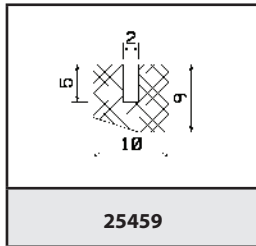

25459

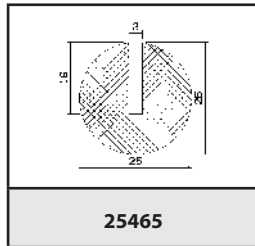

25465

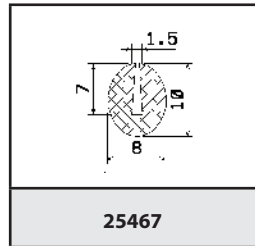

25467

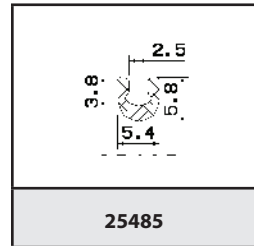

25485

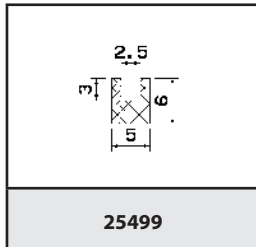

25499

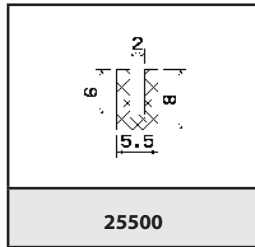

25500

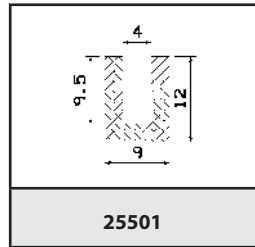

25501

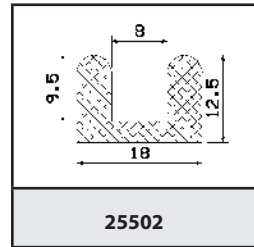

25502

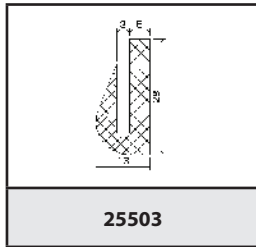

25503

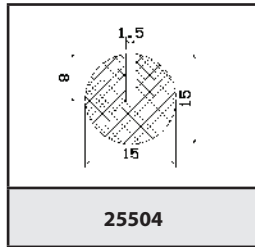

25504

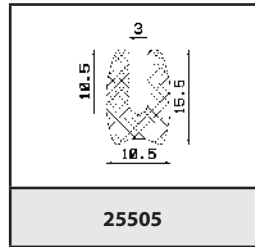

25505

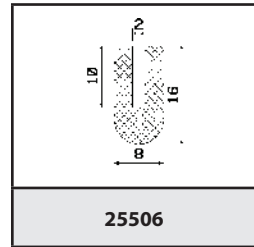

25506

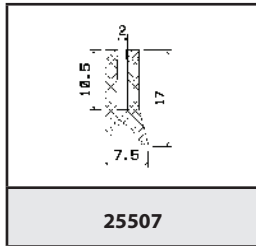

25507

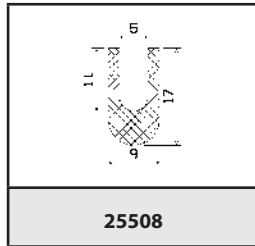

25508

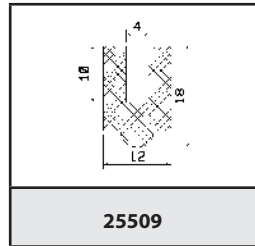

25509

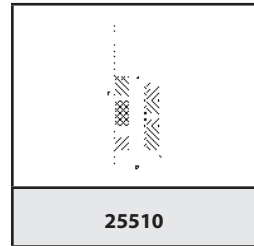

25510



foam, foam / silicone



rubber, silicone

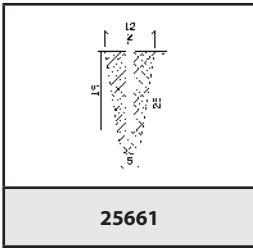

25661

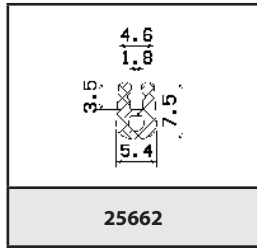

25662

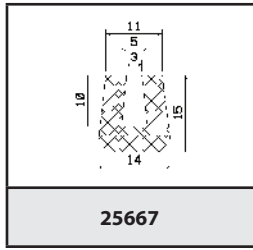

25667

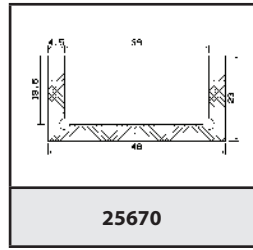

25670

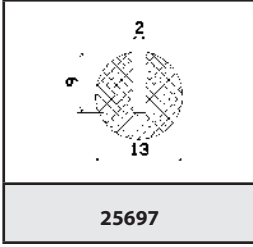

25697

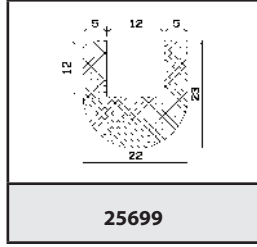

25699

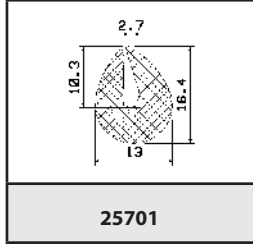

25701

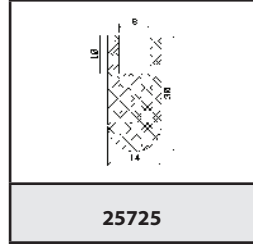

25725

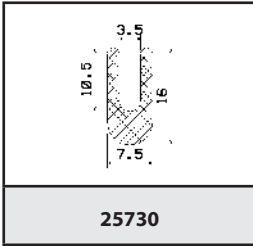

25730

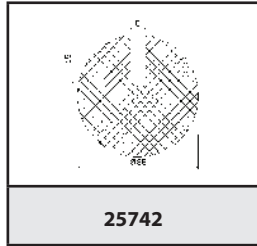

25742

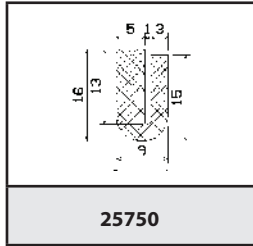

25750

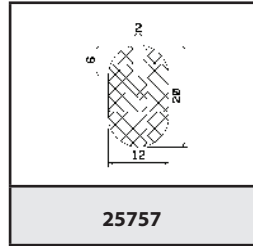

25757

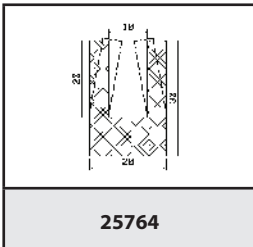

25764

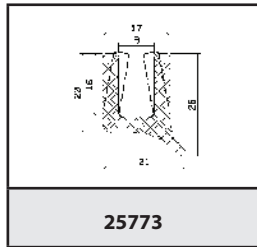

25773

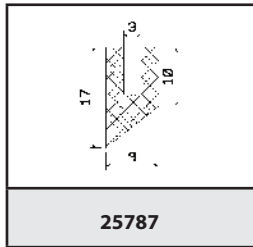

25787

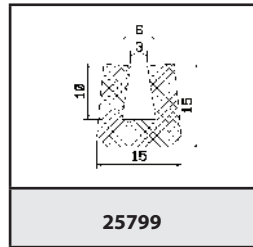

25799

○ foam, foam / silicone

● rubber, silicone

FOAM

(height x width)

02x06mm	04x20mm	06x11mm	09x16mm
02x06mm	04x25mm	06x12mm	09x23mm
02x08mm	04x25mm	06x12mm	09x23mm
02x08mm	04x30mm	06x13mm	10x100mm
02x09mm	04x30mm	06x15mm	10x10mm
02x09mm	04x35mm	06x15mm	10x10mm
02x10mm	04x35mm	06x16mm	10x10mm
02x10mm	04x40mm	06x16mm	10x10mm
02x15mm	04x40mm	06x20mm	10x11mm
02x15mm	04x45mm	06x20mm	10x11mm
02x20mm	04x45mm	06x22mm	10x12mm
02x20mm	04x50mm	06x25mm	10x12mm
02x25mm	04x50mm	06x25mm	10x15mm
02x25mm	04,5x05mm	06x30mm	10x15mm
02x50mm	04,5x06,5mm	06x30mm	10x16mm
02x50mm	05x05mm	06x35mm	10x16mm
03x03mm	05x05mm	06x35mm	10x17mm
03x03,5mm	05x06mm	06x40mm	10x17mm
03x05mm	05x06mm	06x40mm	10x18mm
03x05mm	05x08mm	06x42mm	10x18mm
03x06mm	05x08mm	06x50mm	10x20mm
03x10mm	05x10mm	06x50mm	10x20mm
03x10mm	05x10mm	06x70mm	10x20mm
03x110mm	05x10mm	06,5x08,5mm	10x20mm
03x110mm	05x12mm	07x07mm	10x23mm
03x113mm	05x12mm	07x10mm	10x23mm
03x113mm	05x14mm	07x10mm	10x25mm
03x12mm	05x15mm	07x15mm	10x25mm
03x12mm	05x15mm	07x15mm	10x30mm
03x141mm	05x15mm	07x20mm	10x30mm
03x15mm	05x18mm	07x20mm	10x30mm
03x15mm	05x20mm	07x50mm	10x30mm
03x18mm	05x20mm	07x60mm	10x35mm
03x18mm	05x20mm	07x70mm	10x35mm
03x20mm	05x25mm	08x08mm	10x40mm
03x20mm	05x25mm	08x08mm	10x40mm
03x22mm	05x25mm	08x10mm	10x40mm
03x25mm	05x28mm	08x10mm	10x40mm
03x25mm	05x30mm	08x12mm	10x45mm
03x30mm	05x30mm	08x12mm	10x45mm
03x30mm	05x35mm	08x15mm	10x50mm
03x35mm	05x35mm	08x15mm	10x50mm
03x35mm	05x40mm	08x16mm	10x50mm
03x40mm	05x40mm	08x16mm	10x50mm
03x40mm	05x40mm	08x18mm	10x50mm
03x50mm	05x42mm	08x18mm	10x60mm
03x50mm	05x45mm	08x20mm	10x60mm
03x95mm	05x45mm	08x20mm	10x70mm
04x04mm	05x50mm	08x20mm	10x70mm
04x05mm	05x50mm	08x25mm	10x70mm
04x05mm	05x50mm	08x25mm	11x14mm
04x05,7mm	05x50mm	08x30mm	11x15mm
04x06mm	05x60mm	08x30mm	11x17mm
04x06mm	05x60mm	08x35mm	11x18mm
04x07mm	05x65mm	08x35mm	11x26mm
04x08mm	05x70mm	08x40mm	12x12mm
04x08mm	05x70mm	08x40mm	12x12mm
04x10mm	06x06mm	08x45mm	12x15mm
04x10mm	06x06mm	08x50mm	12x15mm
04x10,5mm	06x08mm	08x50mm	12x15mm
04x12mm	06x08mm	09x09mm	12x16mm
04x12mm	06x09mm	09x09mm	12x17mm
04x15mm	06x09mm	09x11mm	12x18mm
04x15mm	06x100mm	09x12mm	12x18mm
04x16mm	06x10mm	09x12mm	12x20mm
04x20mm	06x10mm	09x16mm	12x20mm

FOAM

(height x width)

12x25mm
12x25mm
12x28mm
12x28mm
12x30mm
12x30mm
12x40mm
12x40mm
12x45mm
12x50mm
12x50mm
12,4x12,4mm
13x13mm
13x18mm
13x20mm
13x30mm
14x14mm
14x16mm
14x17mm
14x18mm
15x15mm
15x15mm
15x15mm
15x18mm
15x18mm
15x20mm
15x20mm
15x25mm
15x25mm
15x30mm
15x30mm
15x30mm
15x30mm
15x35mm
15x35mm
15x40mm
15x40mm
15x40mm
15x45mm
15x45mm
15x50mm
15x50mm
16x16mm
16x16mm
16x20mm
16x20mm
16x22mm
16x22mm
16x28mm
16x28mm
16x30mm
16x30mm
17x20mm
17x24mm
17x24mm
17x25mm
17x25mm
18x18mm
18x18mm
18x20mm
18x20mm
18x22mm
18x22mm
18x25mm
18x25mm
20x100mm
20x20mm

SILICONE

(height x width)

20x20mm
20x20mm
20x25mm
20x25mm
20x30mm
20x30mm
20x30mm
20x30mm
20x35mm
20x35mm
20x40mm
20x40mm
20x45mm
20x45mm
20x50mm
20x50mm
20x50mm
20x50mm
20x60mm
20x60mm
22x33mm
23x23mm
23x25mm
23x25mm
25x25mm
25x25mm
25x30mm
25x30mm
25x33mm
25x33mm
25x35mm
25x35mm
25x40mm
25x40mm
25x45mm
25x50mm
25x50mm
28x28mm
30x30mm
30x30mm
30x35mm
30x35mm
30x40mm
30x40mm
30x40mm
30x50mm
30x50mm
30x50mm
40x40mm
40x40mm
40x50mm
40x50mm
40x60mm
40x60mm
45x45mm
45x50mm
45x50mm
50x50mm
50x50mm

02x10mm
02x15mm
02x20mm
02x25mm
02x50mm
02x57mm
03x10mm
03x20mm
03x25mm
03x30mm
03x40mm
03x50mm
03x100mm
03,5x03,5mm
04x05,5mm
04x09,5mm
04x23mm
04x25mm
04x40mm
04x40mm
04x40mm
04x60mm
05x07,5mm
05x14mm
05x20mm
05x35mm
05x40mm
05x40mm
05x50mm
05x80mm
06x10mm
06x12mm
06x25mm
06x60mm
06x80mm
07x70mm
07x90mm
08x14mm
08x18mm
08x40mm
08x40mm
08x80mm
10x10mm
10x15mm
10x16mm
10x20mm
10x25mm
10x30mm
10x40mm
12x14mm
12x15mm
12x18mm
13x16mm
14x14mm
14x15mm
14x18mm
14x20mm
15x15mm
15x19mm
15x20mm
15x25mm
15x30mm
16x16mm
16x20mm
20x20mm
20x26mm

20x30mm
25x25mm
25x55mm
25x65mm
27x27mm
30x30mm
50x50mm

SILICONE FOAM

(height x width)

01,50x20mm	06x06mm	18x18mm
02x10mm	06x70mm	18x23mm
02x10,50mm	06,50x06,50mm	18,50x20mm
02x15mm	07x10mm	20x20mm
02x20mm	07x12mm	20x25mm
02x20mm	07x15mm	20x30mm
02x25mm	07x70mm	20x35mm
02x30mm	08x08mm	20x35mm
02x60mm	08x10mm	20x40mm
03x05mm	08x12mm	20x50mm
03x06mm	08x14mm	20x55mm
03x08mm	08x15mm	20x70mm
03x09mm	08x17mm	22x22mm
03x10mm	08x20mm	23x25mm
03x12mm	08x24mm	24x24mm
03x15mm	08x25mm	25x25mm
03x16mm	08x30mm	25x30mm
03x20mm	08x35mm	25x35mm
03x25mm	08x38mm	25x40mm
03x26,30mm	08x40mm	25x65mm
03x30mm	08x45mm	30x30mm
03x35mm	09x13mm	30x35mm
03x40mm	09x20mm	30x40mm
03x60mm	09,50x14mm	30x45mm
03x8mm	10x10mm	30x50mm
04x05mm	10x12mm	30x60mm
04x10mm	10x13mm	35x35mm
04x12mm	10x15mm	35x40mm
04x15mm	10x16mm	40x40mm
04x20mm	10x18mm	40x40mm
04x22mm	10x20mm	40x40mm
04x30mm	10x22mm	40x100mm
04x40mm	10x25mm	50x50mm
04,50x10mm	10x30mm	60x60mm
04,50x15mm	10x35mm	
04,50x70mm	10x40mm	
04,75x25,40mm	10x45mm	
05x05mm	10x50mm	
05x06mm	10x60mm	
05x08mm	11x16mm	
05x10mm	12x12mm	
05x15mm	12x14mm	
05x20mm	12x15mm	
05x22,50mm	12x16mm	
05x25mm	12x18mm	
05x30mm	12x20mm	
05x35mm	12x25mm	
05x40mm	12x30mm	
05x50mm	12x35mm	
05x59mm	12x40mm	
05x60mm	13x20mm	
05x70mm	15x15mm	
05x80mm	15x17mm	
06x06mm	15x18mm	
06x08mm	15x18,50mm	
06x10mm	15x20mm	
06x10mm	15x22mm	
06x12mm	15x25mm	
06x15mm	15x30mm	
06x16mm	15x35mm	
06x20mm	15x40mm	
06x25mm	15x50mm	
06x30mm	16x16mm	
06x40mm	16x18mm	
06x50mm	16x20mm	
06x60mm	17x20mm	

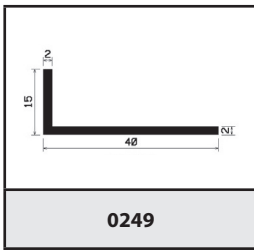

0249

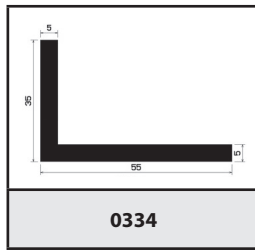

0334

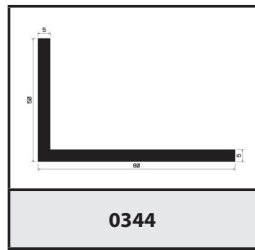

0344

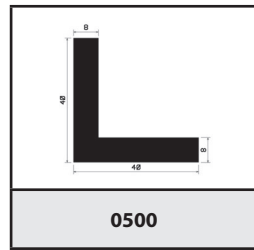

0500

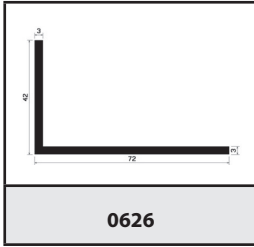

0626

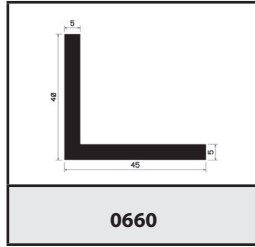

0660

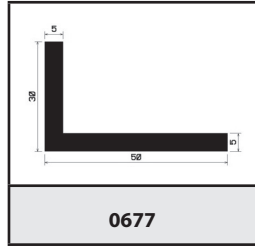

0677

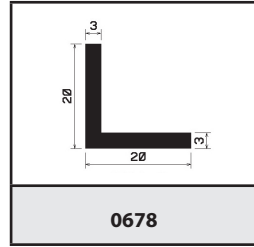

0678

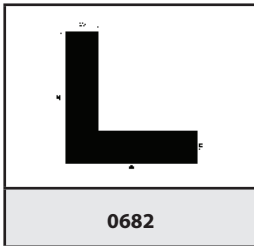

0682

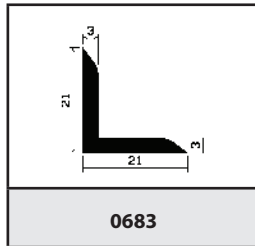

0683

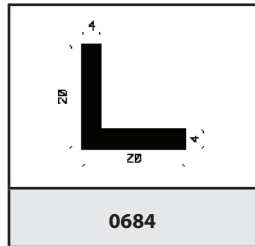

0684

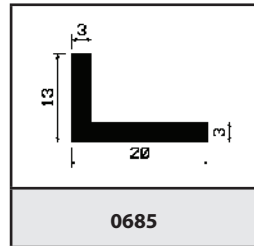

0685

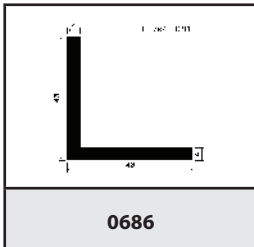

0686

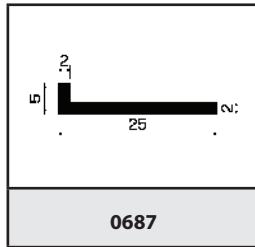

0687

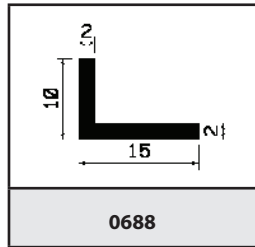

0688

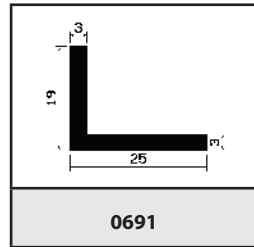

0691

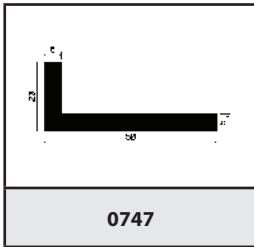

0747

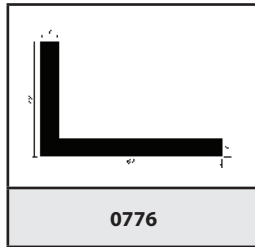

0776

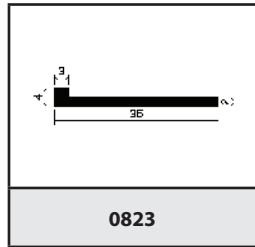

0823

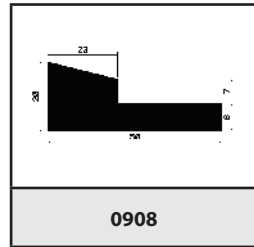

0908

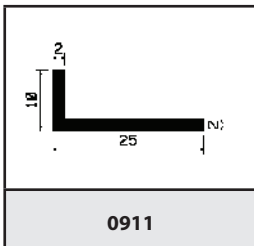

0911

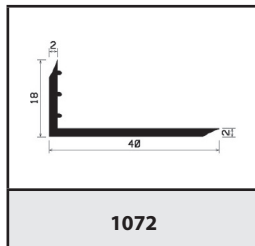

1072

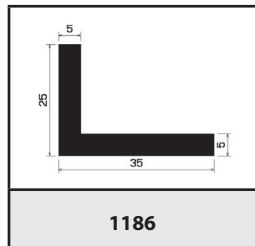

1186

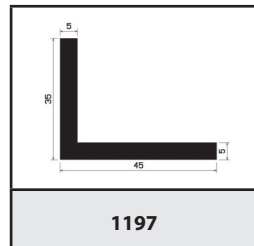

1197

○ foam, foam / silicone

● rubber, silicone

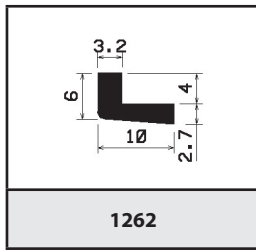

1262

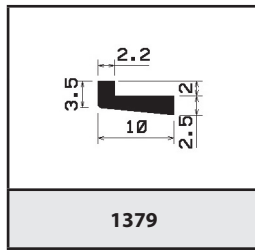

1379

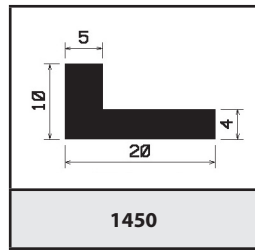

1450

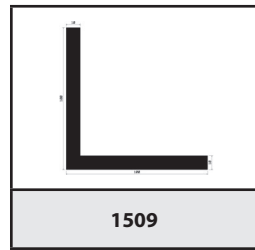

1509

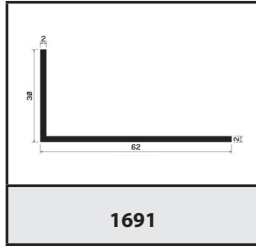

1691

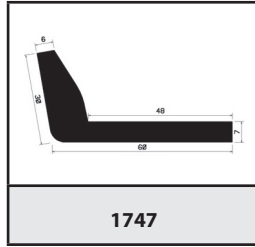

1747

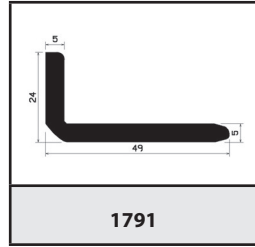

1791

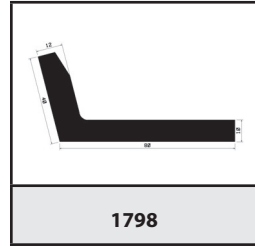

1798

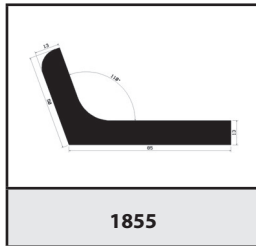

1855

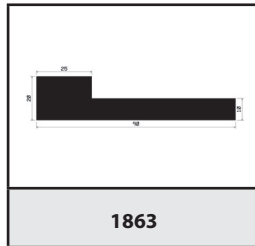

1863

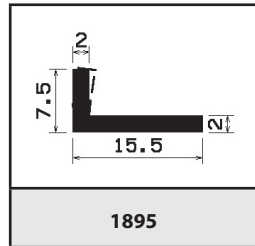

1895

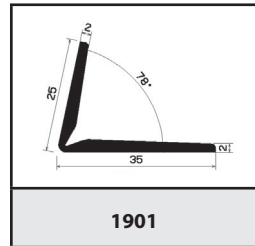

1901

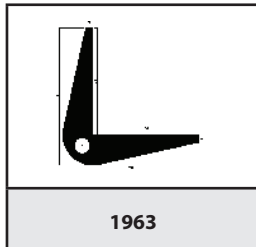

1963

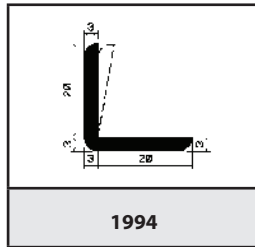

1994

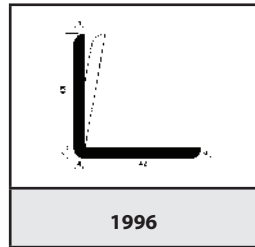

1996

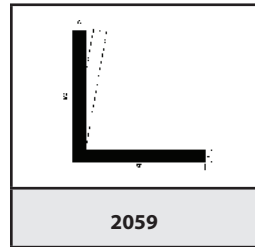

2059

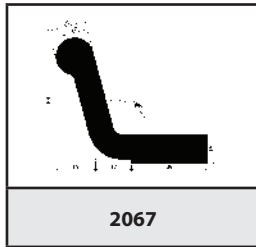

2067

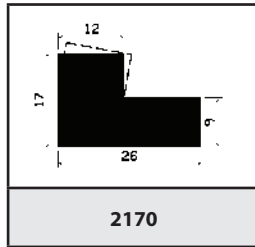

2170

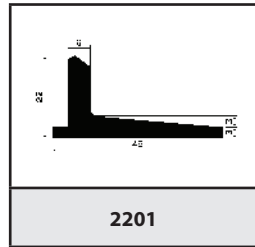

2201

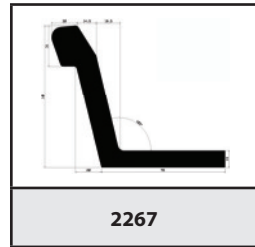

2267

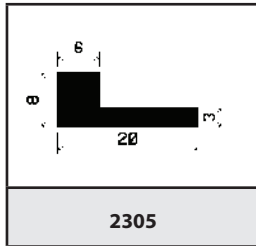

2305

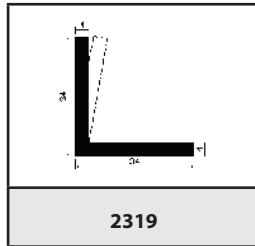

2319

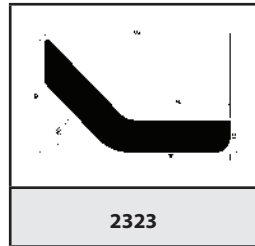

2323

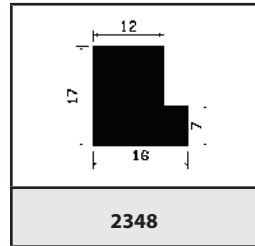

2348



foam, foam / silicone



rubber, silicone

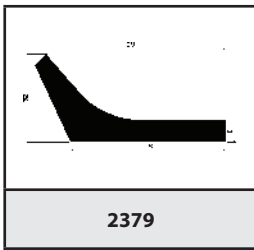

2379

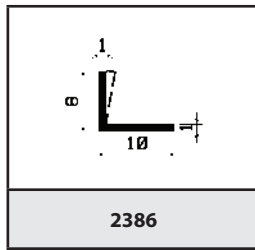

2386

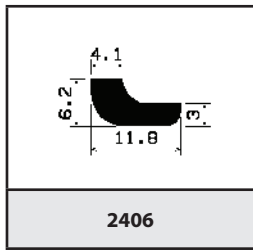

2406

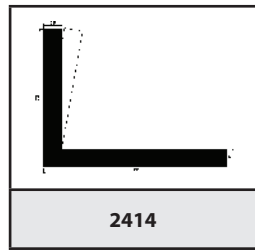

2414

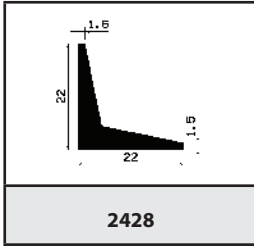

2428

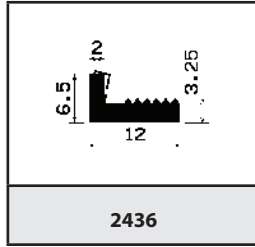

2436

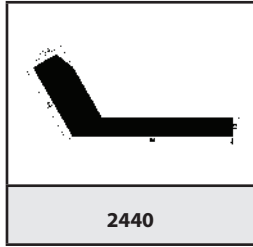

2440

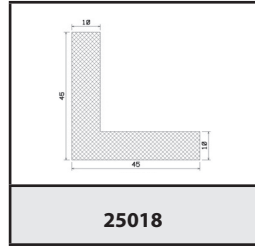

25018

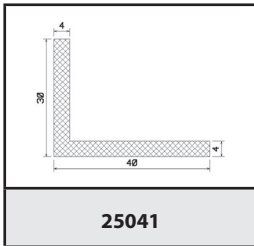

25041

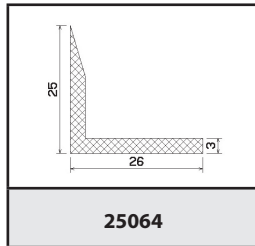

25064

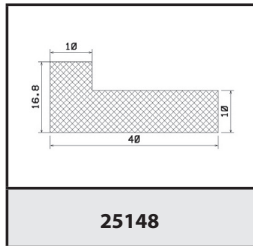

25148

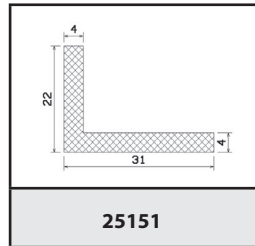

25151

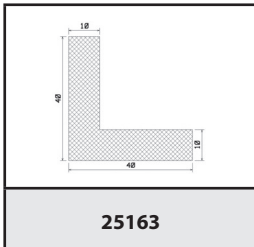

25163

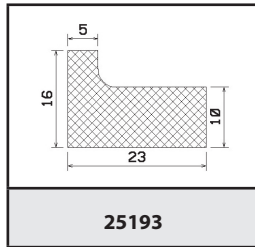

25193

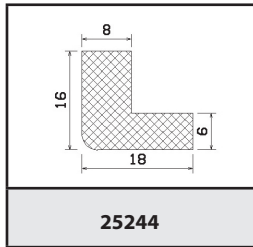

25244

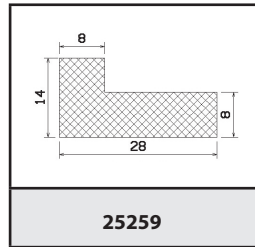

25259

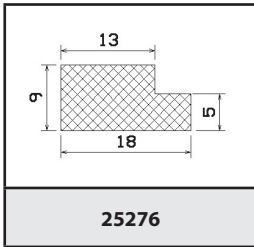

25276

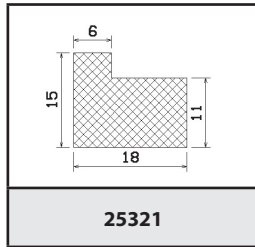

25321

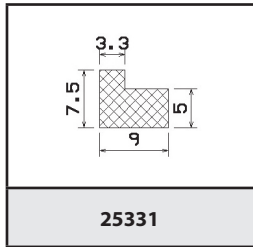

25331

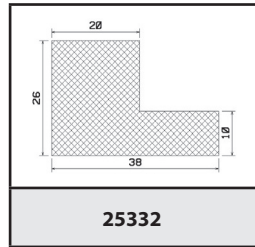

25332

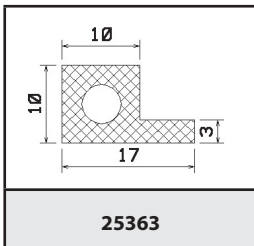

25363

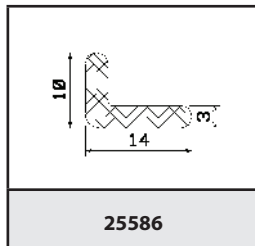

25586

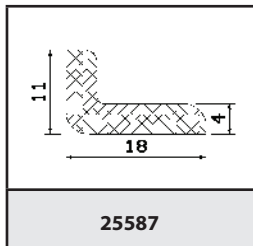

25587

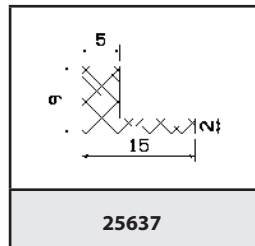

25637

○ foam, foam / silicone

● rubber, silicone

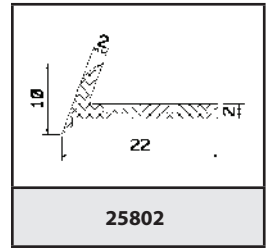
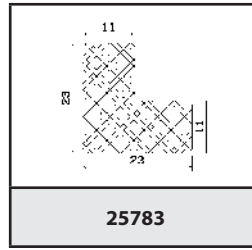
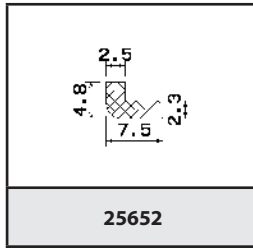

○ foam, foam / silicone

● rubber, silicone

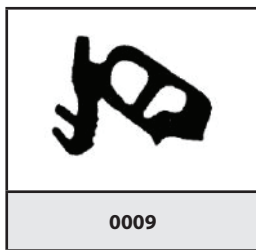

0009

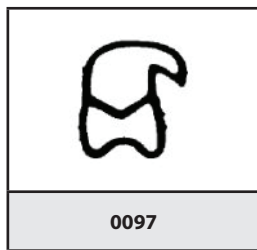

0097

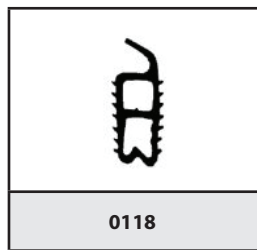

0118

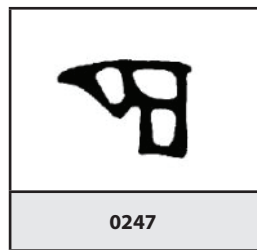

0247

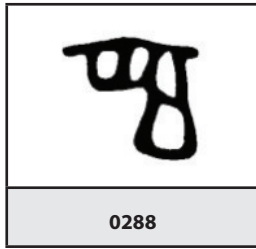

0288

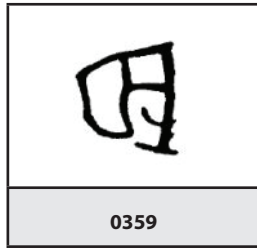

0359



0375

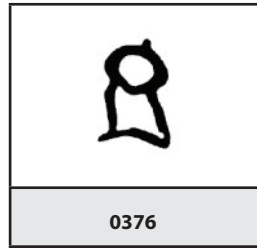

0376

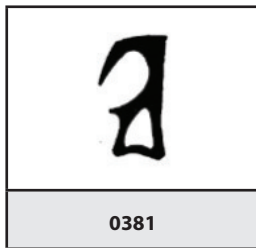

0381

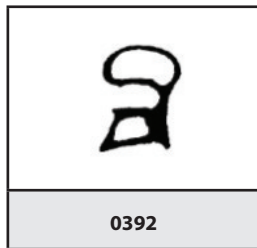

0392

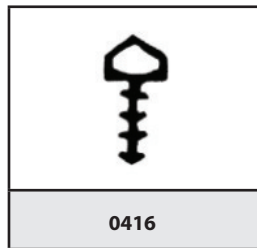

0416

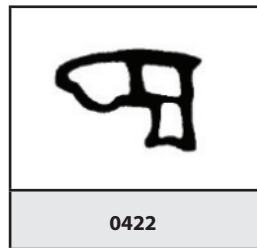

0422

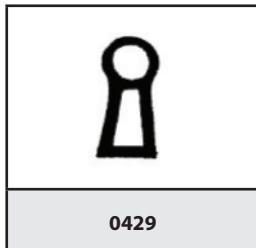

0429

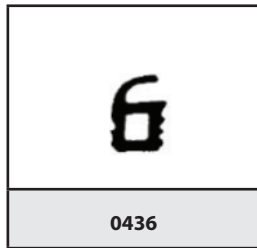

0436

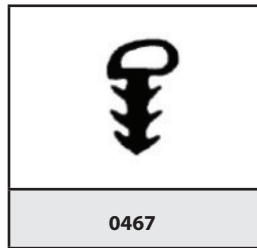

0467



0490

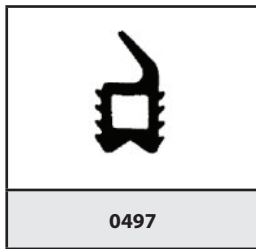

0497

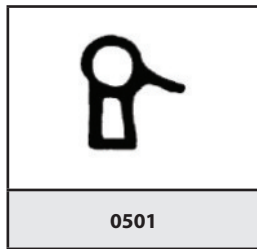

0501

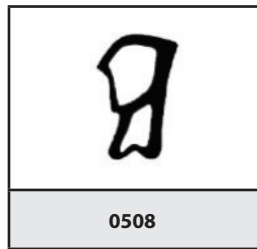

0508



0510

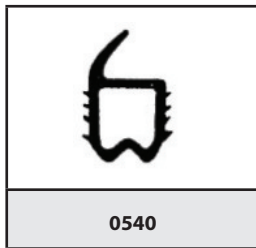

0540

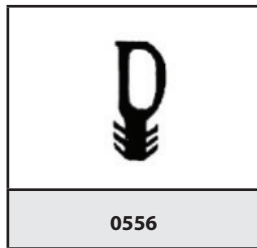

0556

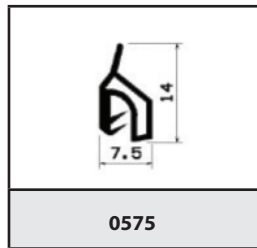

0575

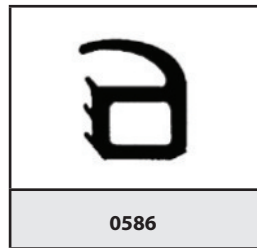

0586

○ foam, foam / silicone

● rubber, silicone

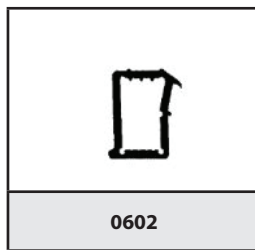

0602



0619



0634

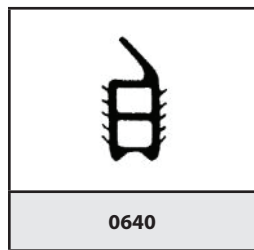

0640

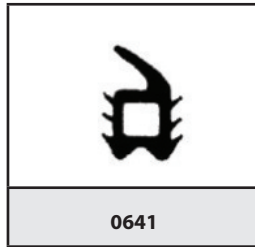

0641

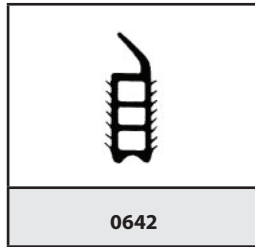

0642

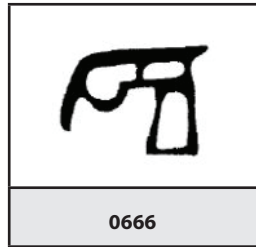

0666

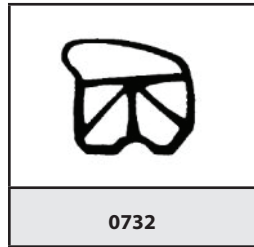

0732

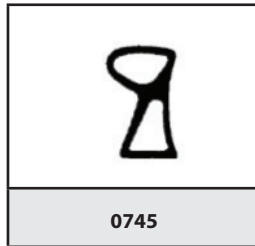

0745

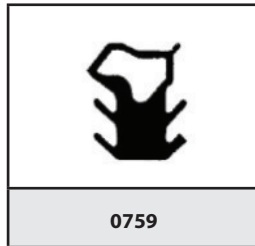

0759

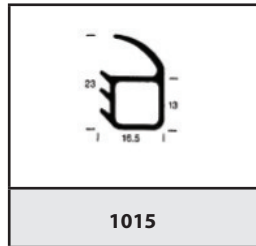

1015

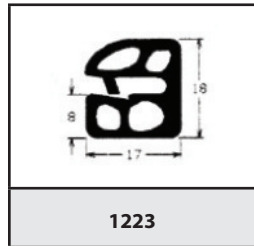

1223

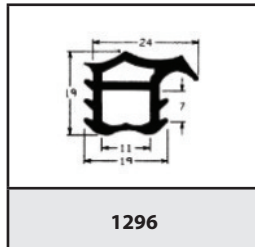

1296

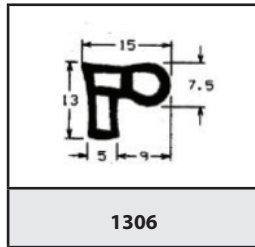

1306

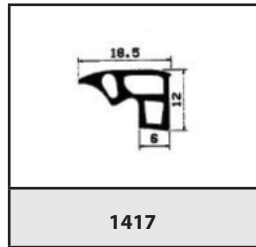

1417

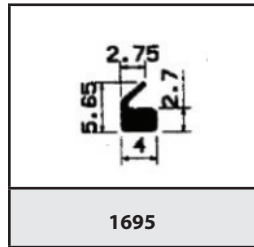

1695

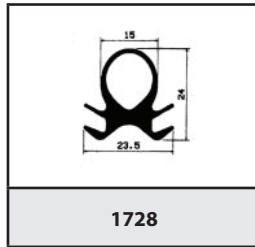

1728

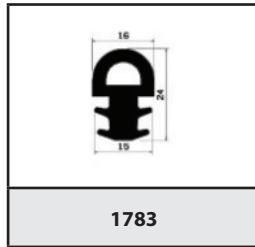

1783

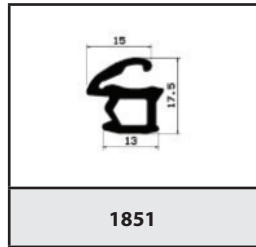

1851

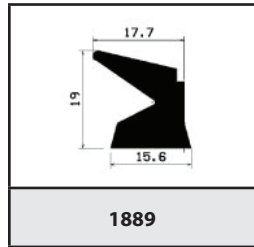

1889

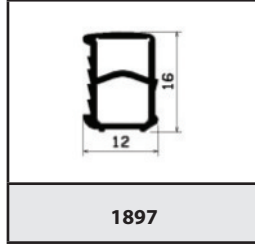

1897

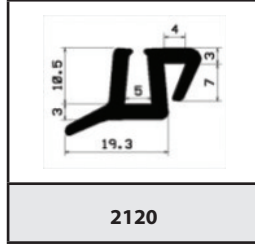

2120

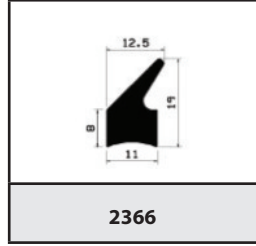

2366

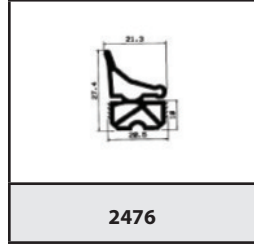

2476

○ foam, foam / silicone

● rubber, silicone

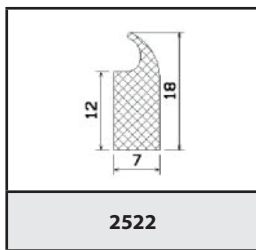

2522

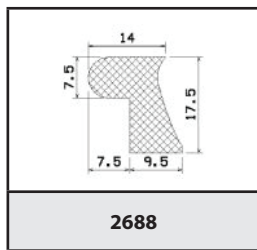

2688

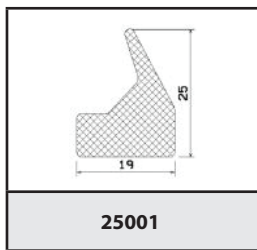

25001

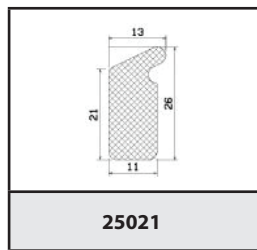

25021

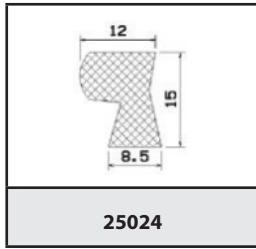

25024

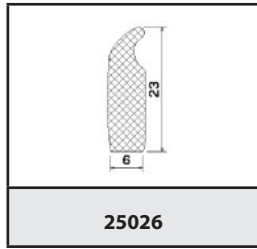

25026

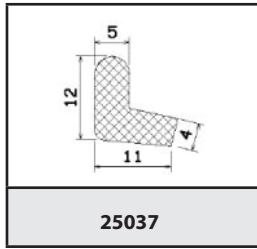

25037

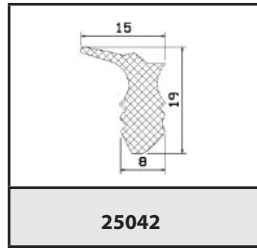

25042

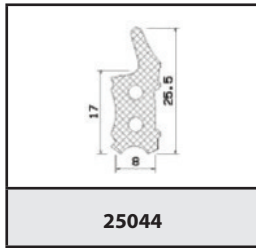

25044

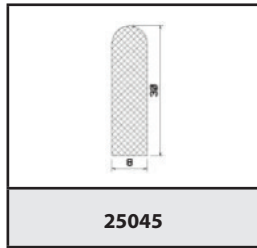

25045

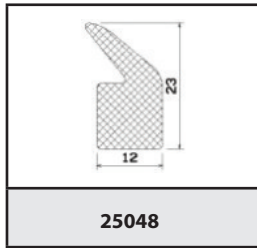

25048

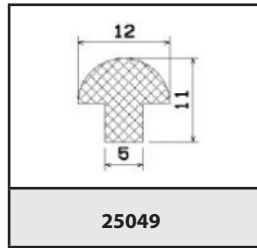

25049

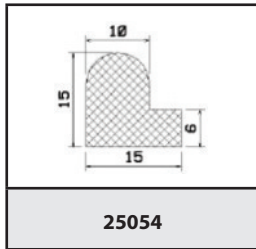

25054

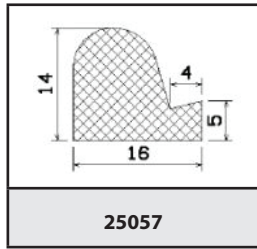

25057

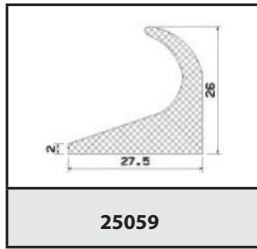

25059

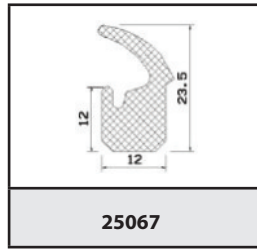

25067

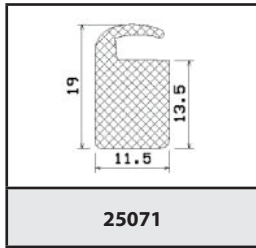

25071

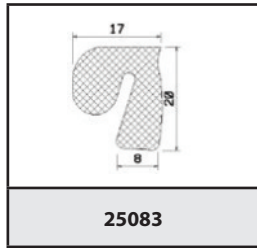

25083

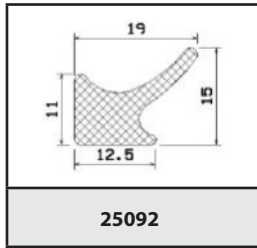

25092

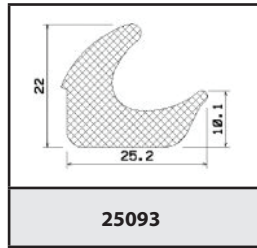

25093

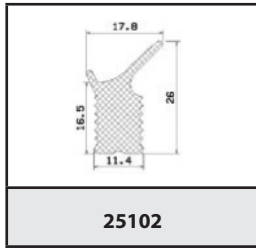

25102

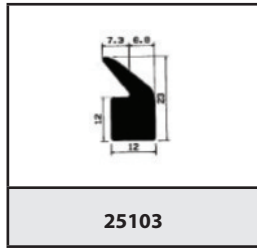

25103

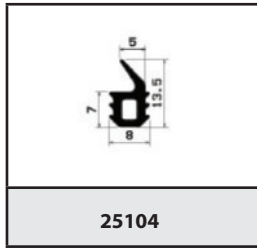

25104





....Immediate sealing effect

Address:

Vrbovec 321, 671 24 Vrbovec, Česká republika

Email:

info@aditeg.cz

Telephone / fax

+420 515 320 023 / +420 515 320 024

CRN / TIN

26905710 / CZ26905710

www.aditeg.cz