

The effective technology and complex services

**Farmet**

ⒸZ KATALOG NÁHRADNÍCH DÍLŮ ⒸB CATALOGUE OF SPARE PARTS ⒸD ERSATZTEILLISTE  
ⒸRU КАТАЛОГ ЗАПАСНЫХ ЧАСТЕЙ ⒸF CATALOGUE DES PIÈCES DE RECHANGE ⒸPL KATALOG CZĘŚCI ZAMIENNYCH

# КОМПАКТОМАТ K1000PS

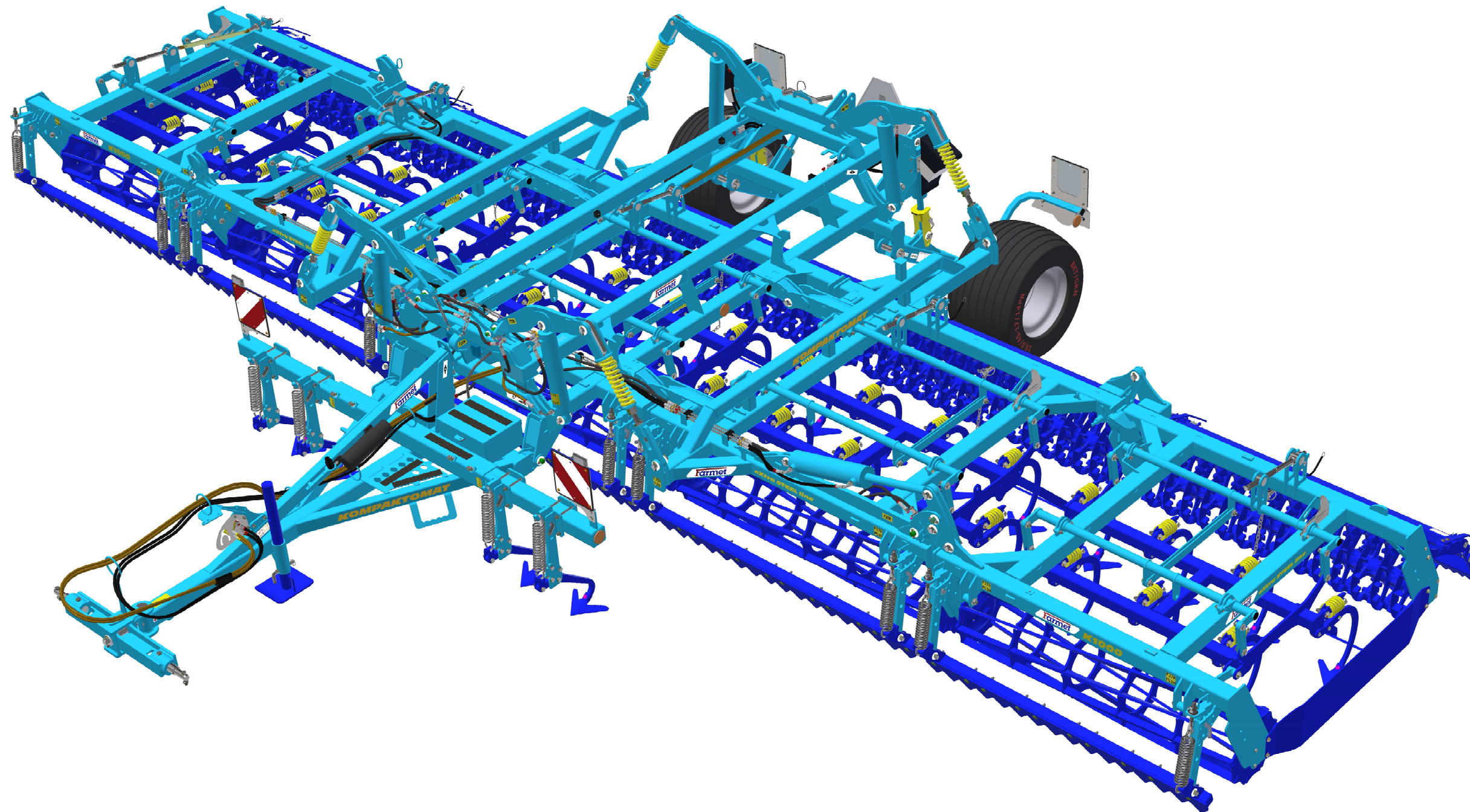

ⒸZ Platnost pro vrcholové | výrobní číslo stroje ⒸB Validity for the top | serial number of the machine  
ⒸD Gültigkeit für die Haupt- | Herstellungsnummer der Maschine ⒸRU Действительно для главного | заводского номера машины  
ⒸF Validité du numéro de référence | de série de la machine ⒸPL Obowiązuje dla numeru głównego | seryjnego maszyny

**9303983 | 2023/0414**

Farmet a. s.  
Jiřinková 276  
552 03 Česká Skalice, CZ

phone: +420 491 450 111  
GSM: +420 774 715 738

Id. No.: 46504931  
Tax Id. No.: CZ46504931

web: [www.farmet.eu](http://www.farmet.eu)  
e-mail: [dzt@farmet.cz](mailto:dzt@farmet.cz)

ⒸZ NAVIGACE STROJE

Ⓓ NAVIGATION DER MASCHINE

Ⓕ NAVIGATION DE LA MACHINE

ⒸB NAVIGATION OF THE MACHINE

ⒸU НАВИГАЦИЯ МАШИНЫ

ⒸL NAWIGACJA MASZYNY

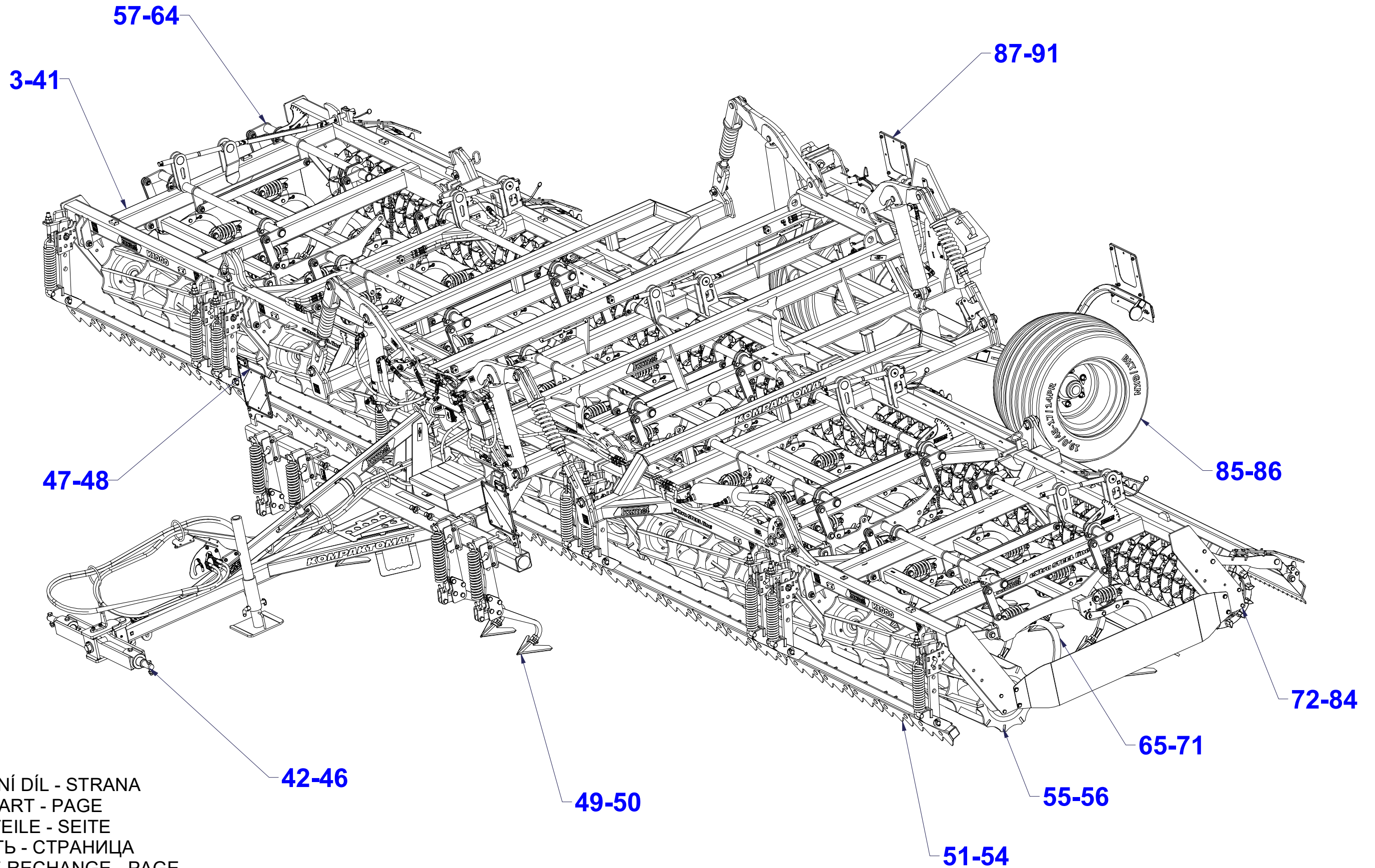

ⒸZ NÁHRADNÍ DÍL - STRANA

ⒸB SPARE PART - PAGE

Ⓓ ERSATZTEILE - SEITE

ⒸU ЗАПЧАСТЬ - СТРАНИЦА

Ⓕ PIÈCE DE RECHANGE - PAGE

ⒸL CZĘŚCI ZAMIENNE - STRONA

Ⓒ POLOTOVAR STROJE

Ⓓ MASCHINEN-HALBFABRIKAT

Ⓕ MACHINE - SEMI-PRODUIT

Ⓖ SEMIFINISHED MACHINE

Ⓡ ПОЛУФАБРИКАТ МАШИНЫ

Ⓟ PÓLFABRYKAT MASZYNY



**VZ00021644**

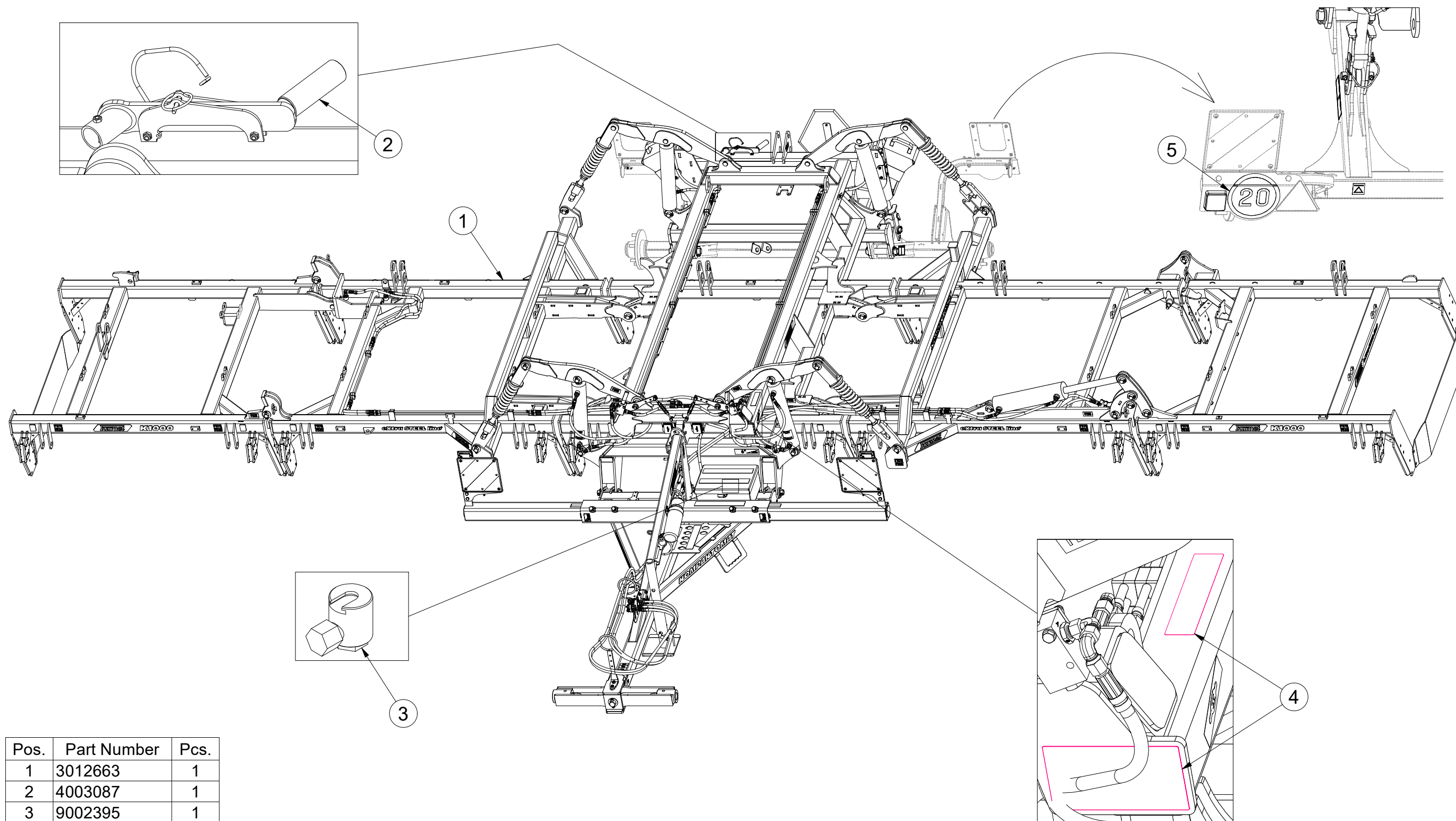

Pos.	Part Number	Pcs.
1	3012663	1
2	4003087	1
3	9002395	1
4	4025948	1
5	4026236	1

Ⓒ POLOTOVAR STROJE

Ⓓ MASCHINEN-HALBFABRIKAT

Ⓕ MACHINE - SEMI-PRODUIT

Ⓖ SEMIFINISHED MACHINE

Ⓡ ПОЛУФАБРИКАТ МАШИНЫ

Ⓟ PÓLFABRYKAT MASZYN



**3012663**

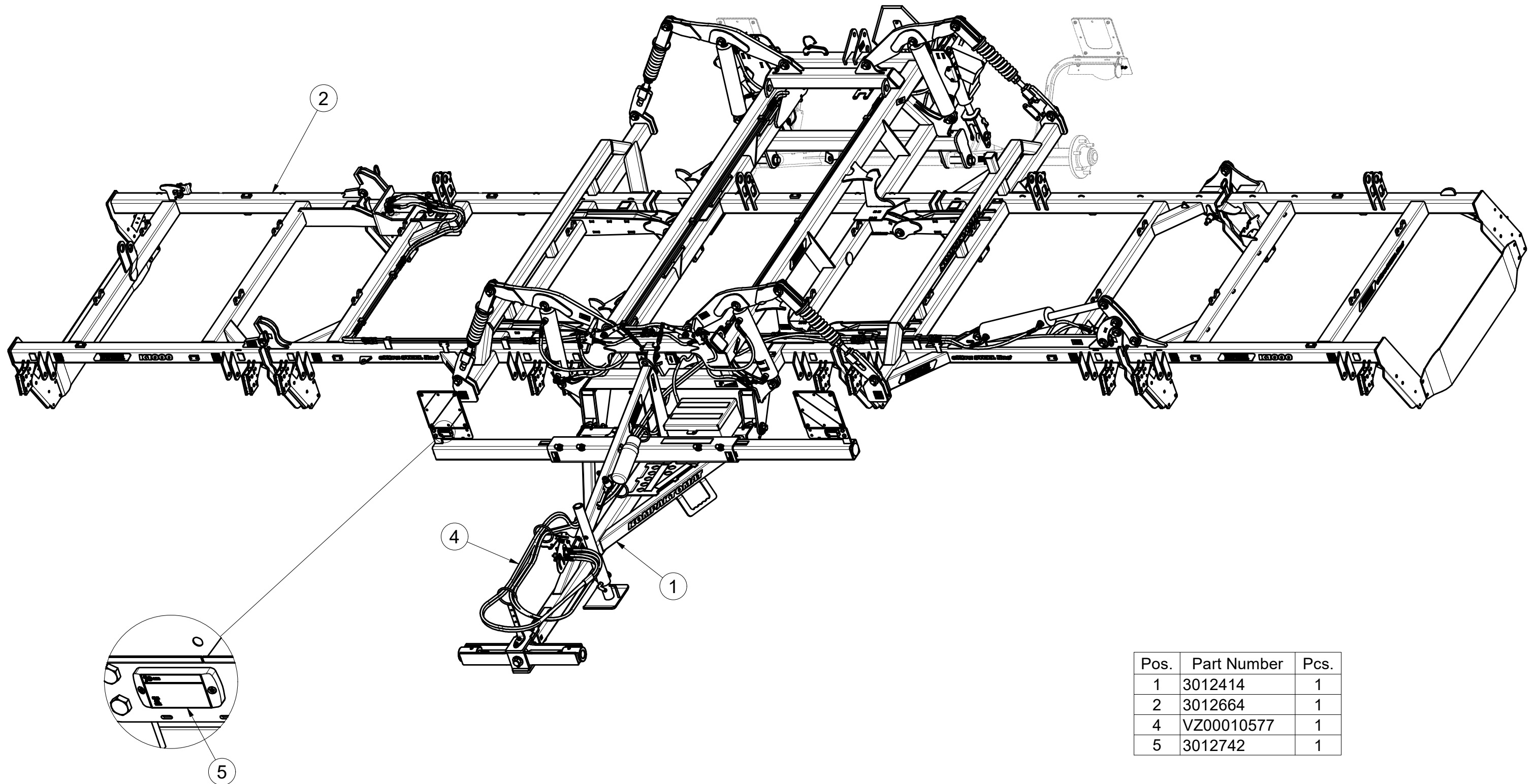

Pos.	Part Number	Pcs.
1	3012414	1
2	3012664	1
4	VZ00010577	1
5	3012742	1

☉ POLOTOVAR STROJE

Ⓧ MASCHINEN-HALBFABRIKAT

Ⓧ MACHINE - SEMI-PRODUIT

Ⓧ SEMIFINISHED MACHINE

Ⓧ ПОЛУФАБРИКАТ МАШИНЫ

Ⓧ PÓLFABRYKAT MASZYN



**3012663**

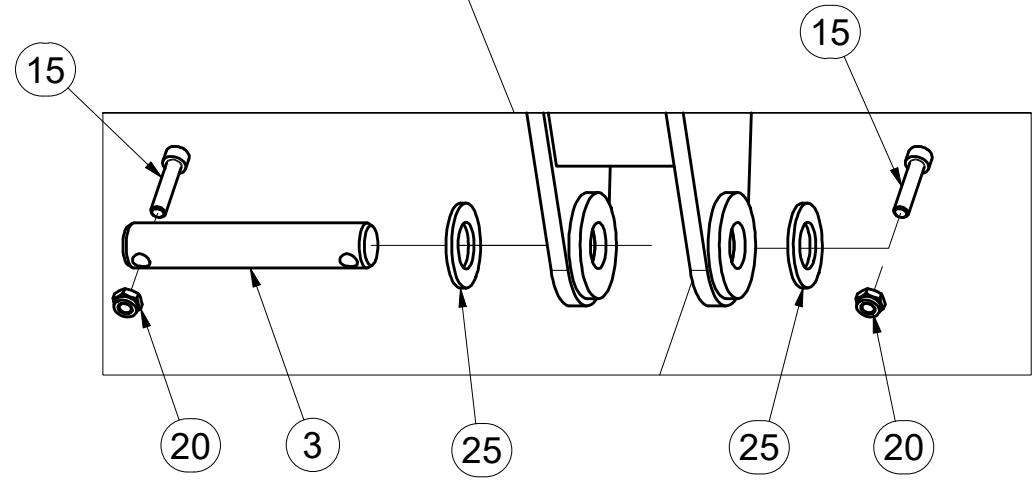
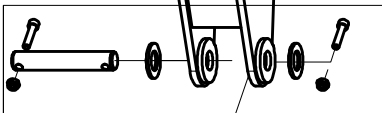
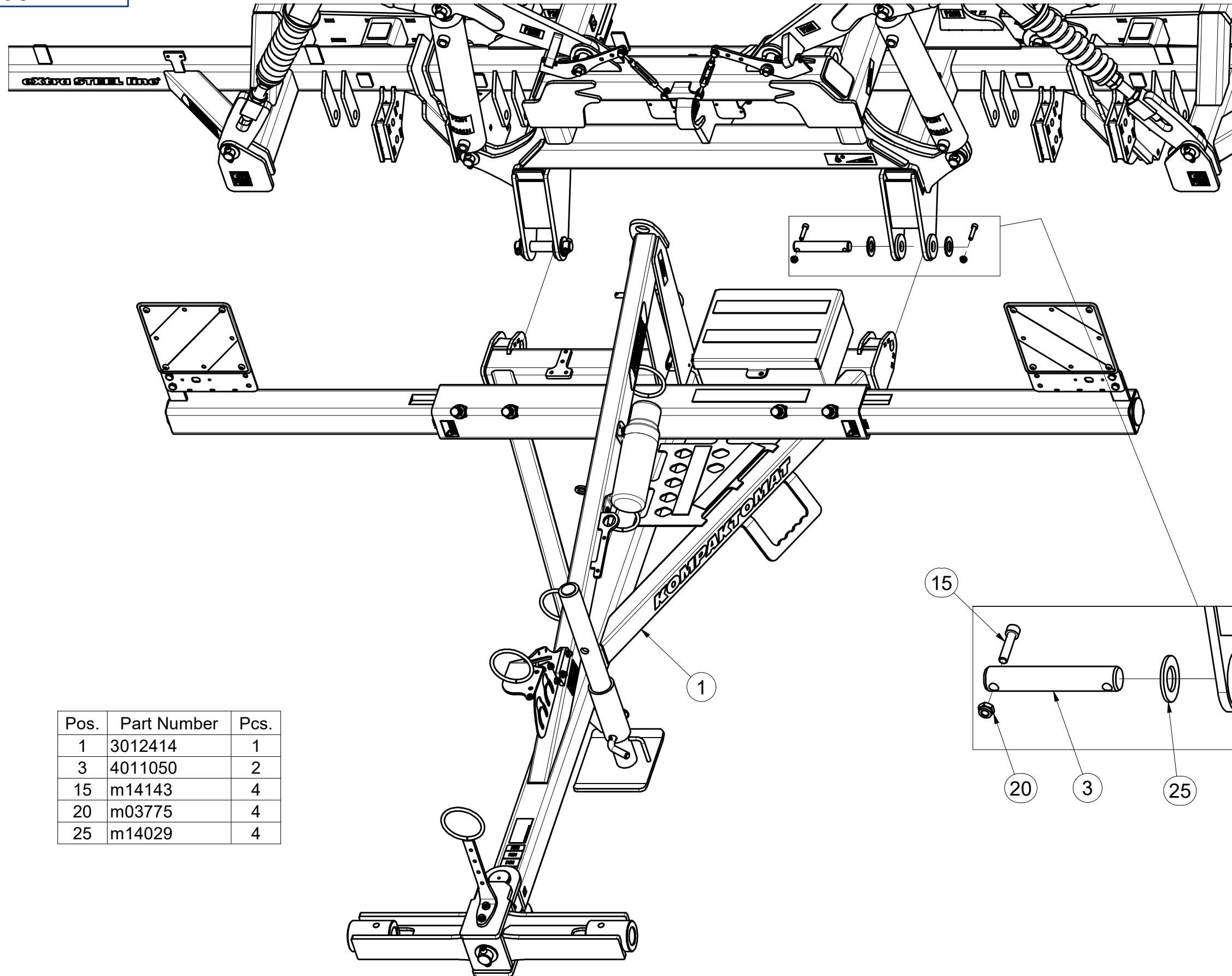

Pos.	Part Number	Pcs.
1	3012414	1
3	4011050	2
15	m14143	4
20	m03775	4
25	m14029	4

Ⓒ POLOTOVAR STROJE

Ⓓ MASCHINEN-HALBFABRIKAT

Ⓕ MACHINE - SEMI-PRODUIT

Ⓖ SEMIFINISHED MACHINE

Ⓡ ПОЛУФАБРИКАТ МАШИНЫ

Ⓟ PÓŁFABRYKAT MASZYNY



**3012664**

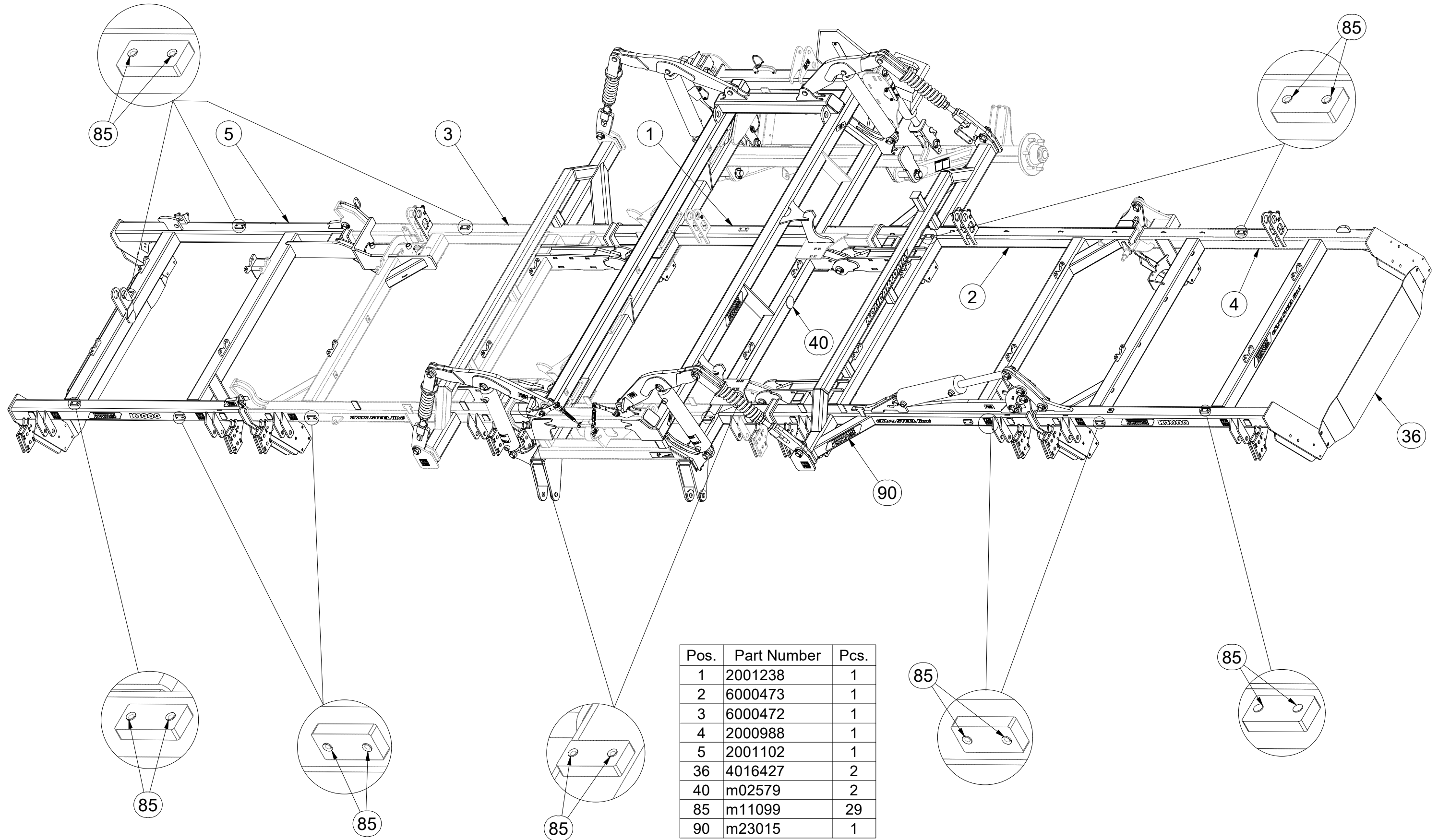

Pos.	Part Number	Pcs.
1	2001238	1
2	6000473	1
3	6000472	1
4	2000988	1
5	2001102	1
36	4016427	2
40	m02579	2
85	m11099	29
90	m23015	1

☉ POLOTOVAR STROJE

☐ MASCHINEN-HALBFABRIKAT

☉ MACHINE - SEMI-PRODUIT

☉ SEMIFINISHED MACHINE

☉ ПОЛУФАБРИКАТ МАШИНЫ

☉ PÓLFABRYKAT MASZYNY



**3012664**

Pos.	Part Number	Pcs.
1	2001238	1
3	6000472	1
9	4005363	4
10	4021664	3
11	4007641	4
30	4007584	6
37	VZ00013651	4
54	m13894	12
56	m14143	54
66	m04503	27
67	m03775	60
70	m04043	4
78	m14029	66

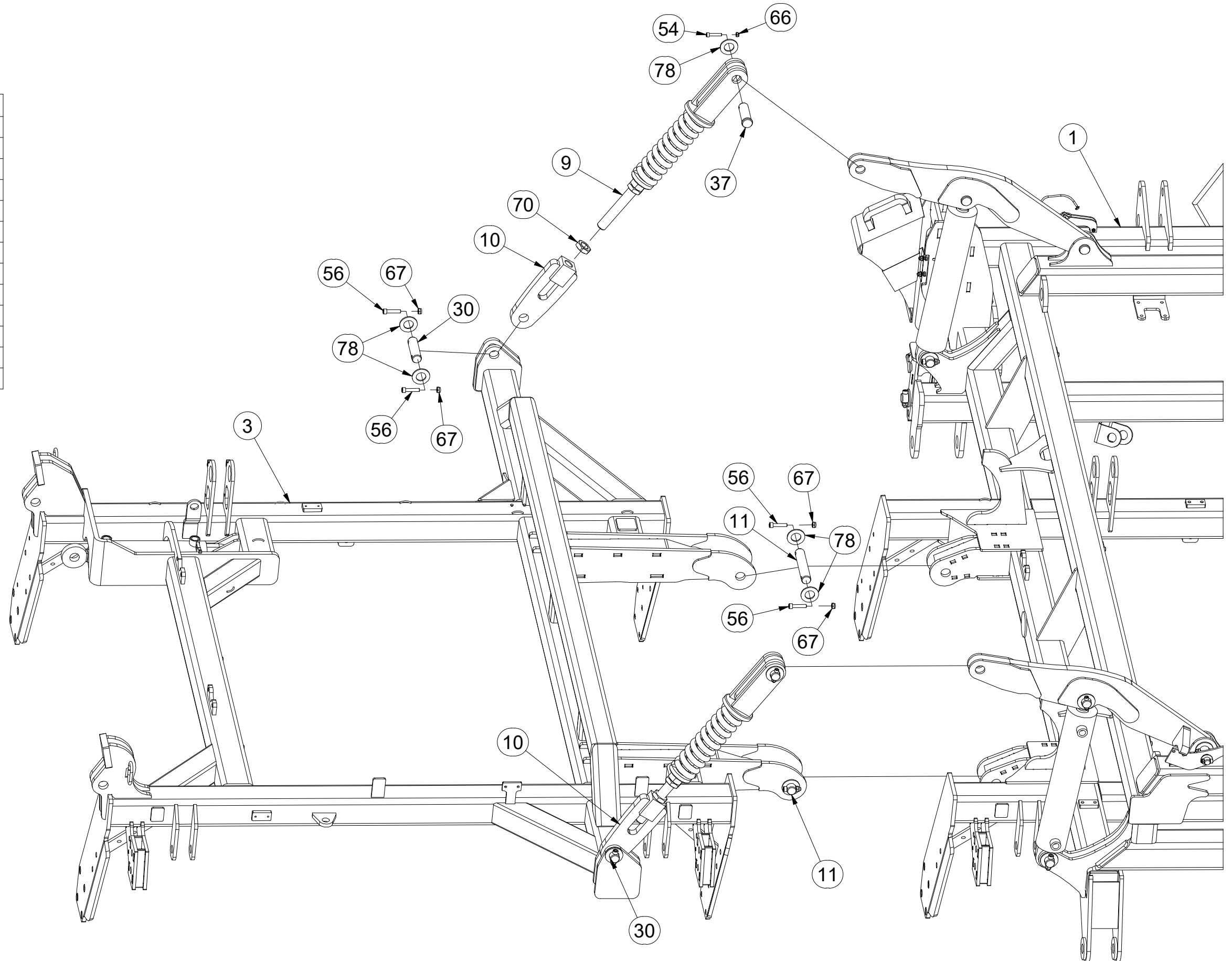

Ⓒ POLOTOVAR STROJE

Ⓓ MASCHINEN-HALBFABRIKAT

Ⓕ MACHINE - SEMI-PRODUIT

Ⓖ SEMIFINISHED MACHINE

Ⓡ ПОЛУФАБРИКАТ МАШИНЫ

Ⓟ PÓŁFABRYKAT MASZYN



**3012664**

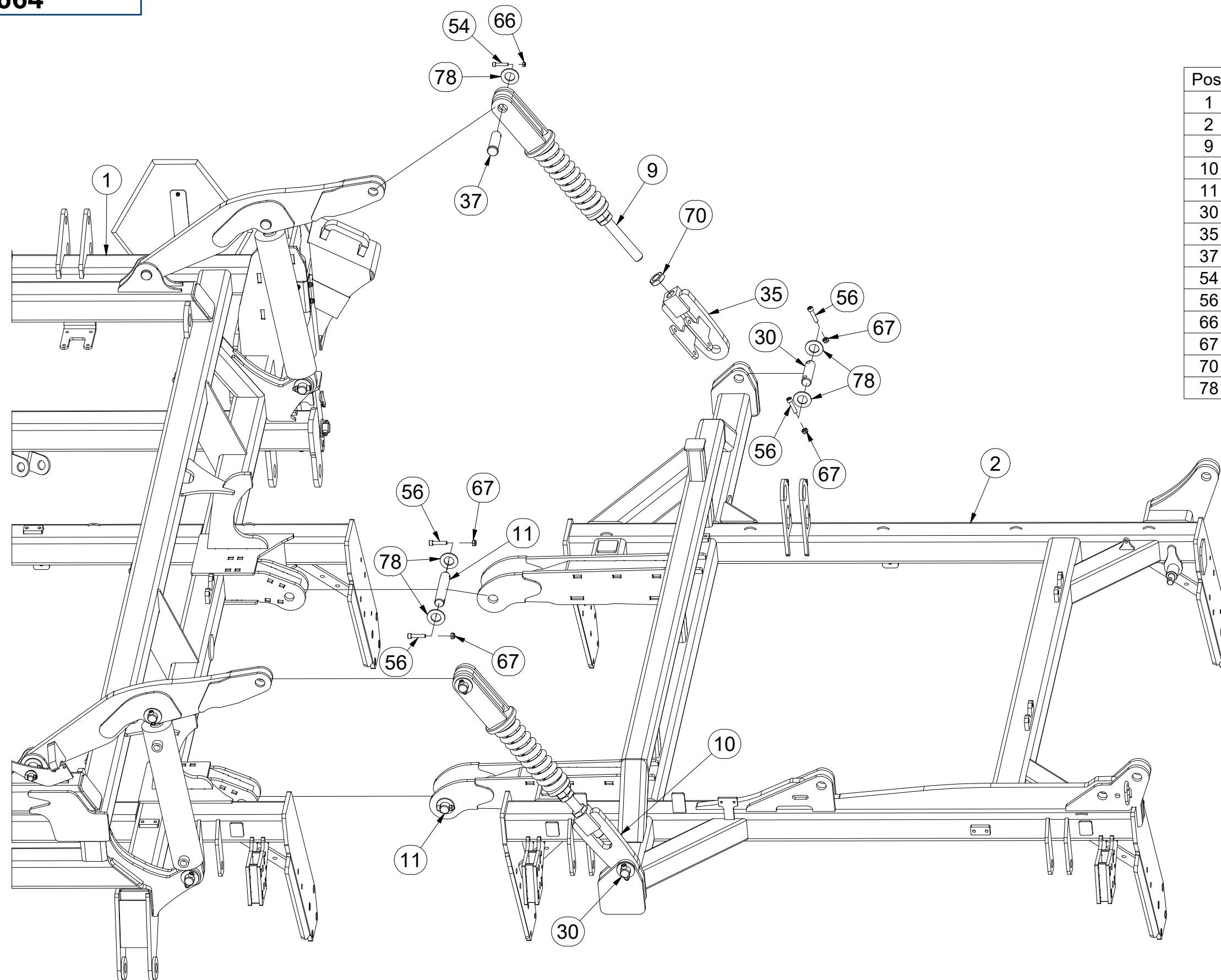

Pos.	Part Number	Pcs.
1	2001238	1
2	6000473	1
9	4005363	4
10	4021664	3
11	4007641	4
30	4007584	6
35	4013669	1
37	VZ00013651	4
54	m13894	12
56	m14143	54
66	m04503	27
67	m03775	60
70	m04043	4
78	m14029	66



☉ POLOTOVAR STROJE

Ⓧ MASCHINEN-HALBFABRIKAT

Ⓧ MACHINE - SEMI-PRODUIT

Ⓧ SEMIFINISHED MACHINE

Ⓧ ПОЛУФАБРИКАТ МАШИНЫ

Ⓧ PÓLFABRYKAT MASZYNY



**3012664**

Pos.	Part Number	Pcs.
1	2001238	1
7	VZ00030265	1
8	VZ00030266	1
18	VZ00004544	4
21	VZ00023131	2
23	4025823	8
25	m09964	3
26	VZ00030260	2
31	4008234	10
53	m09870	3
55	m04612	6
56	m14143	54
66	m04503	27
67	m03775	60
76	m01209	10
77	m14030	3
78	m14029	66

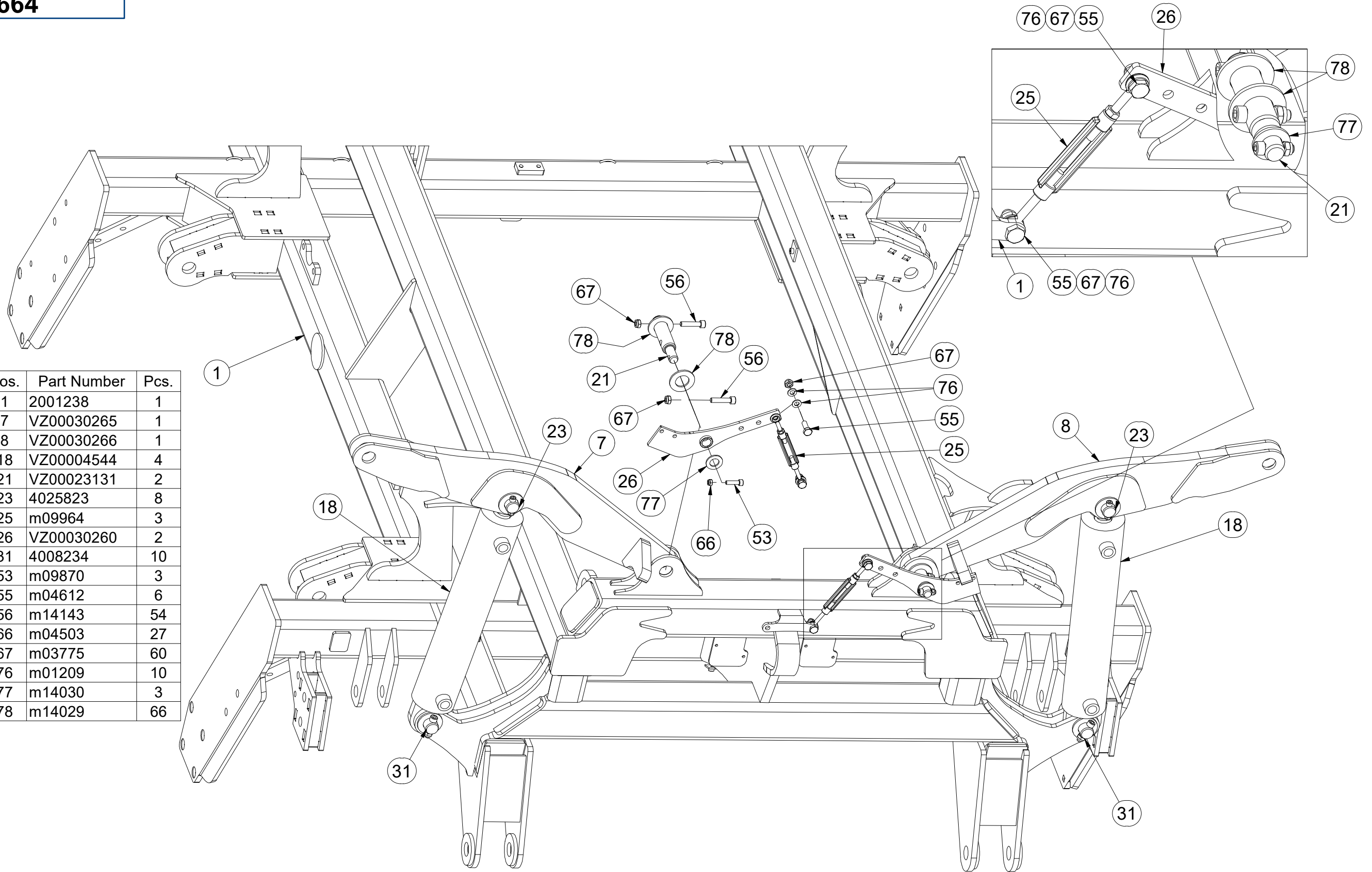

☉ POLOTOVAR STROJE

Ⓧ MASCHINEN-HALBFABRIKAT

Ⓣ MACHINE - SEMI-PRODUIT

Ⓢ SEMIFINISHED MACHINE

Ⓡ ПОЛУФАБРИКАТ МАШИНЫ

Ⓛ PÓŁFABRYKAT MASZYN



**3012664**

Pos.	Part Number	Pcs.
1	2001238	1
6	VZ00030264	2
18	VZ00004544	4
23	4025823	8
31	4008234	10
54	m13894	12
56	m14143	54
66	m04503	27
67	m03775	60
78	m14029	66

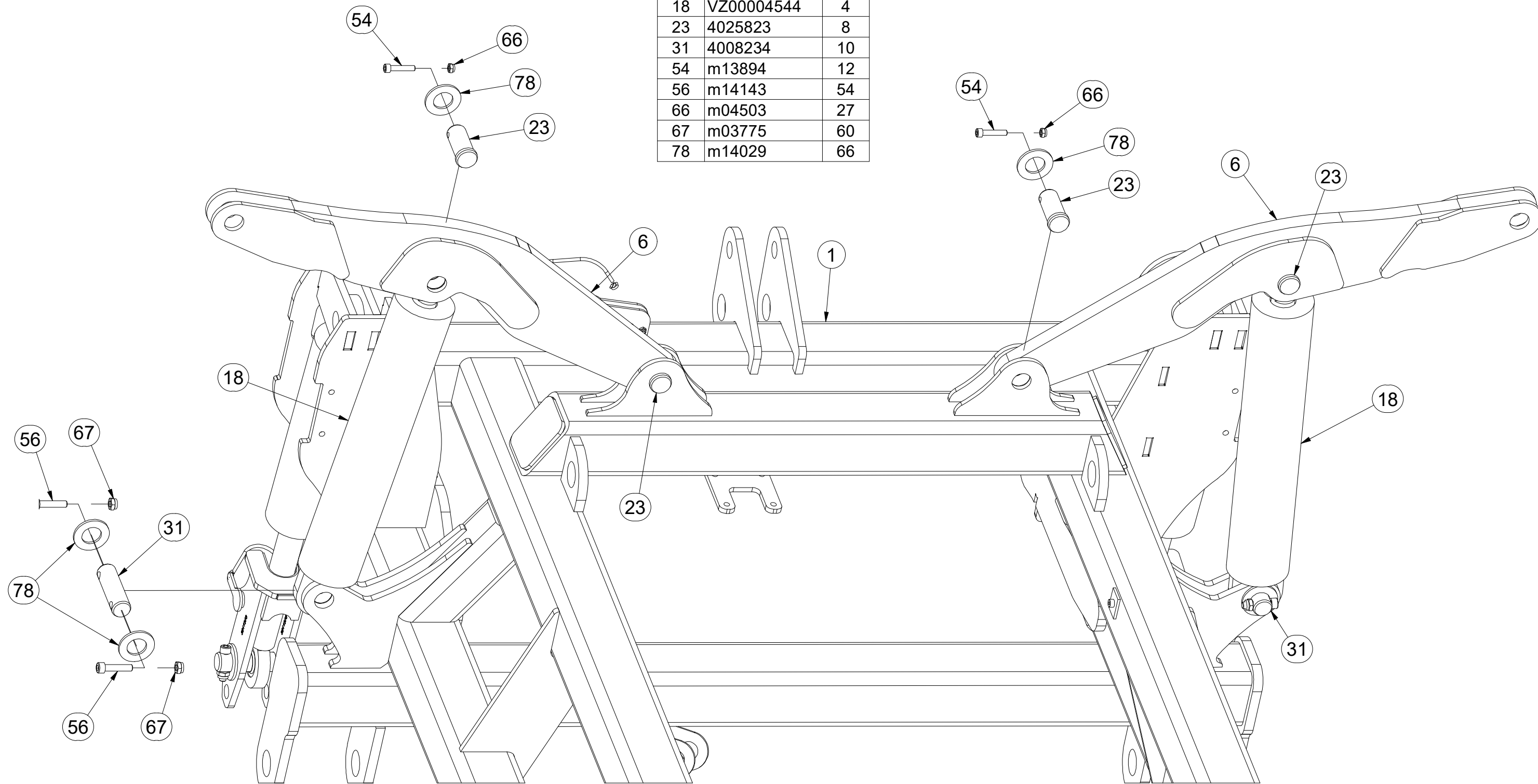

☉ POLOTOVAR STROJE

☉ MASCHINEN-HALBFABRIKAT

☉ MACHINE - SEMI-PRODUIT

☉ SEMIFINISHED MACHINE

☉ ПОЛУФАБРИКАТ МАШИНЫ

☉ PÓLFABRYKAT MASZYNY



**3012664**

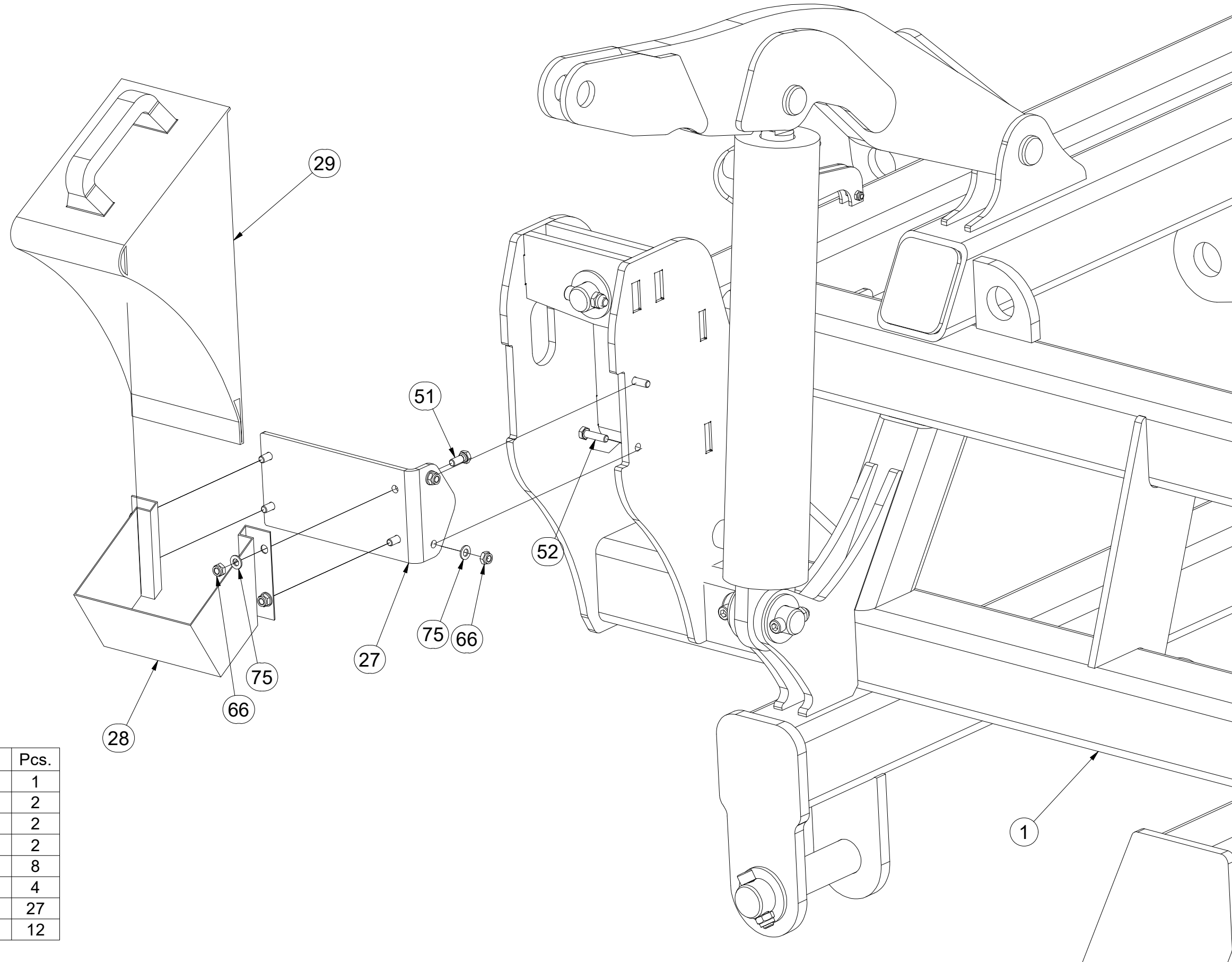

Pos.	Part Number	Pcs.
1	2001238	1
27	4010309	2
28	m12572	2
29	m16186	2
51	m01089	8
52	m07788	4
66	m04503	27
75	m01203	12

☉ POLOTOVAR STROJE

☉ MASCHINEN-HALBFABRIKAT

☉ MACHINE - SEMI-PRODUIT

☉ SEMIFINISHED MACHINE

☉ ПОЛУФАБРИКАТ МАШИНЫ

☉ PÓŁFABRYKAT MASZYNY



**3012664**

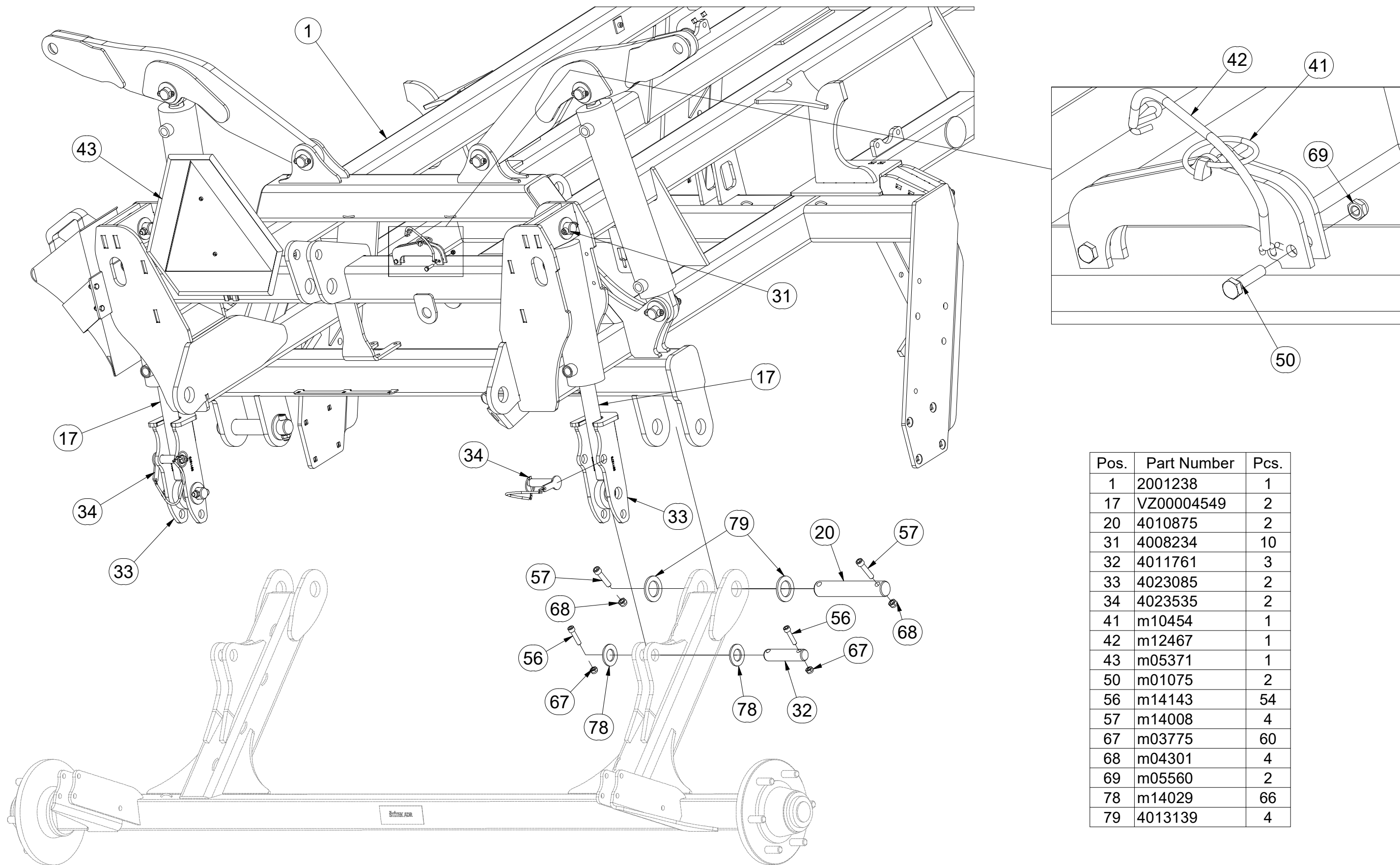

Pos.	Part Number	Pcs.
1	2001238	1
17	VZ00004549	2
20	4010875	2
31	4008234	10
32	4011761	3
33	4023085	2
34	4023535	2
41	m10454	1
42	m12467	1
43	m05371	1
50	m01075	2
56	m14143	54
57	m14008	4
67	m03775	60
68	m04301	4
69	m05560	2
78	m14029	66
79	4013139	4

☉ POLOTOVAR STROJE

Ⓧ MASCHINEN-HALBFABRIKAT

Ⓣ MACHINE - SEMI-PRODUIT

Ⓢ SEMIFINISHED MACHINE

Ⓡ ПОЛУФАБРИКАТ МАШИНЫ

Ⓛ PÓLFABRYKAT MASZYNY



**3012664**

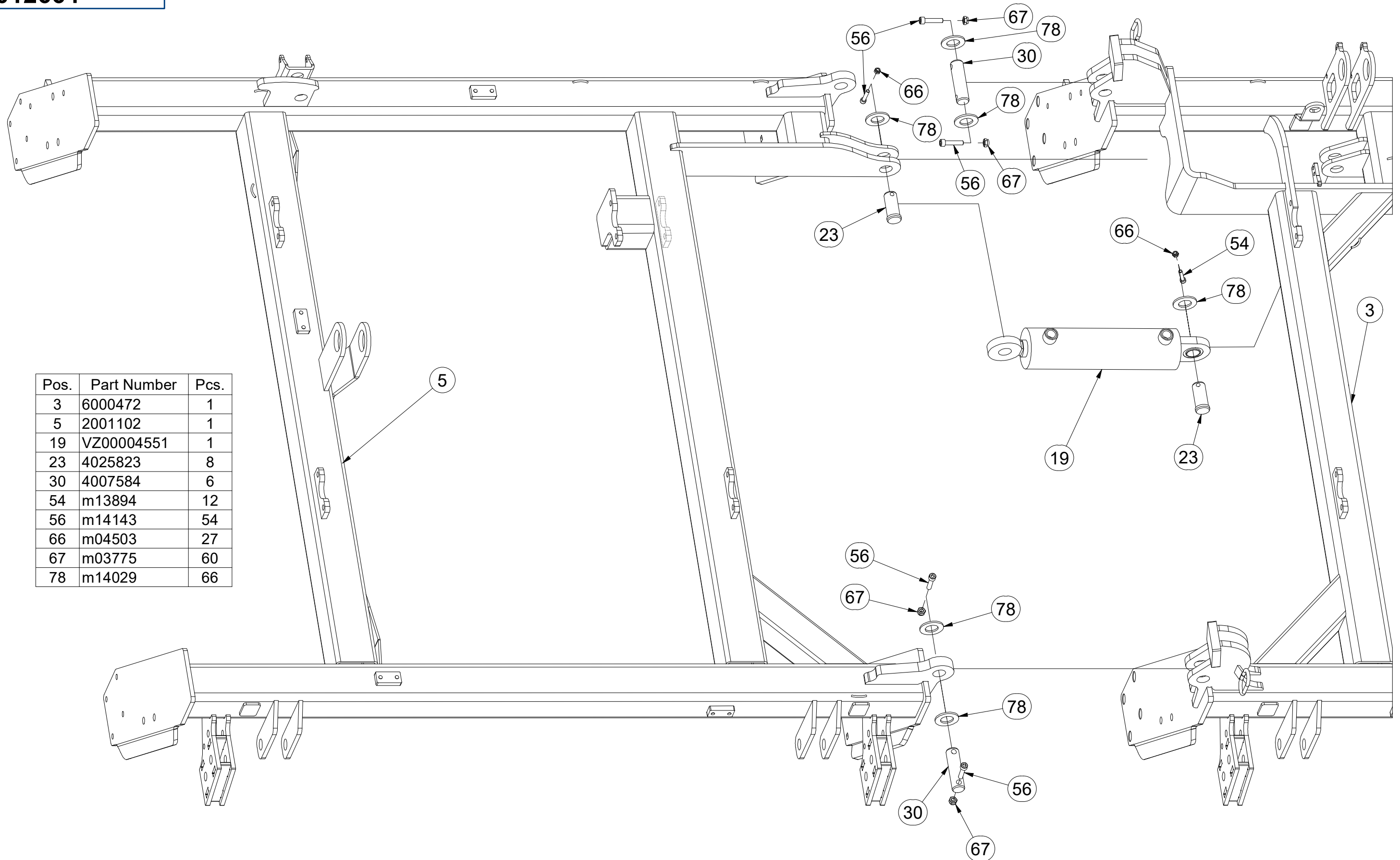

Pos.	Part Number	Pcs.
3	6000472	1
5	2001102	1
19	VZ00004551	1
23	4025823	8
30	4007584	6
54	m13894	12
56	m14143	54
66	m04503	27
67	m03775	60
78	m14029	66

☉ POLOTOVAR STROJE

☐ MASCHINEN-HALBFABRIKAT

☉ MACHINE - SEMI-PRODUIT

☉ SEMIFINISHED MACHINE

☉ ПОЛУФАБРИКАТ МАШИНЫ

☉ PÓŁFABRYKAT MASZYNY



**3012664**

Pos.	Part Number	Pcs.
2	6000473	1
4	2000988	1
12	4007640	1
31	4008234	10
56	m14143	54
67	m03775	60
78	m14029	66

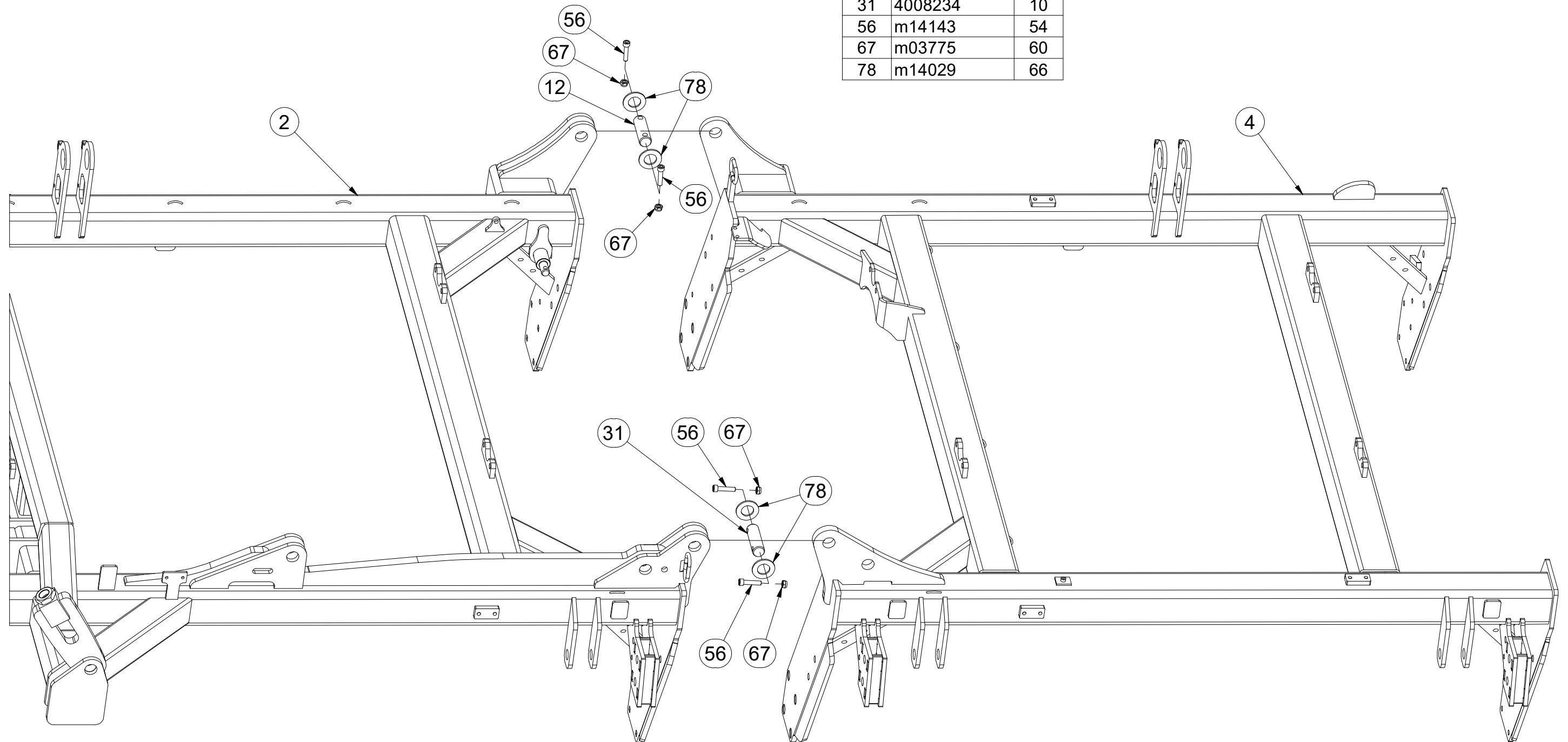

**3012664**

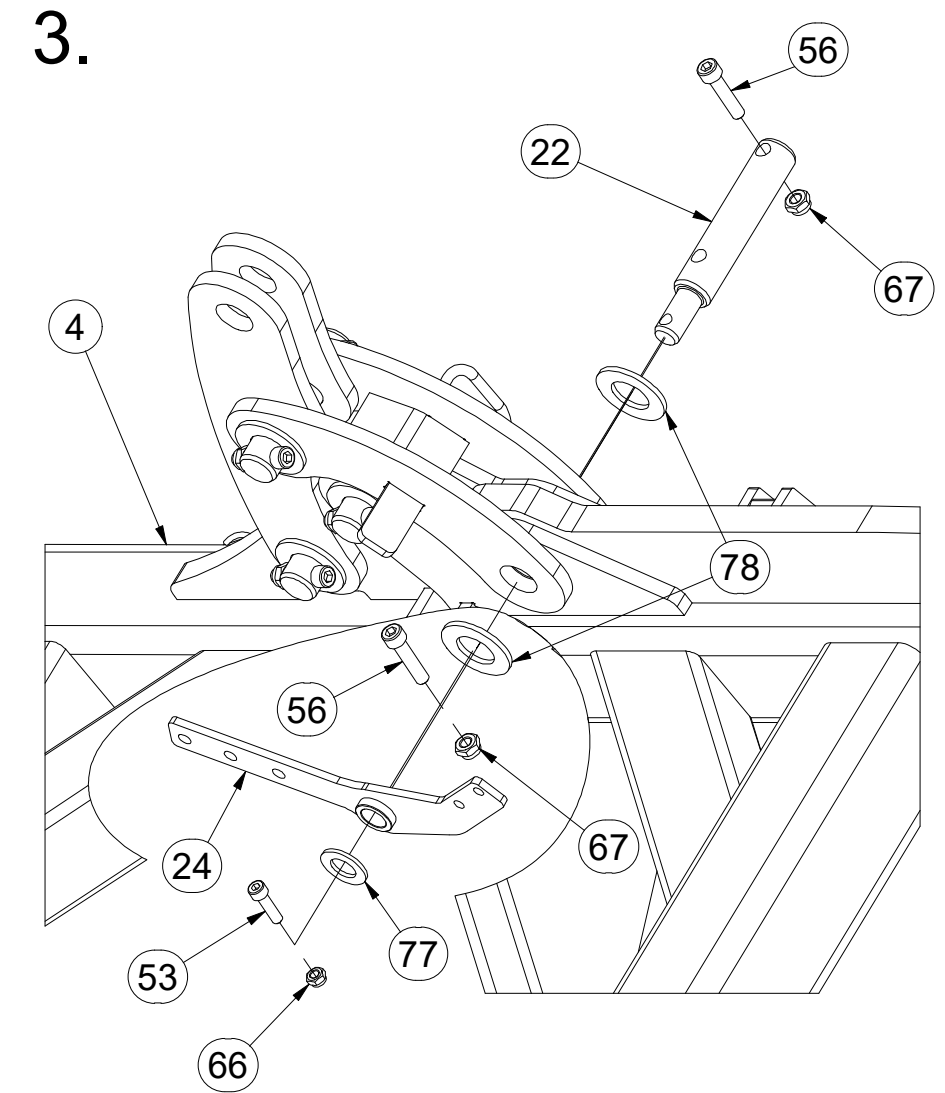
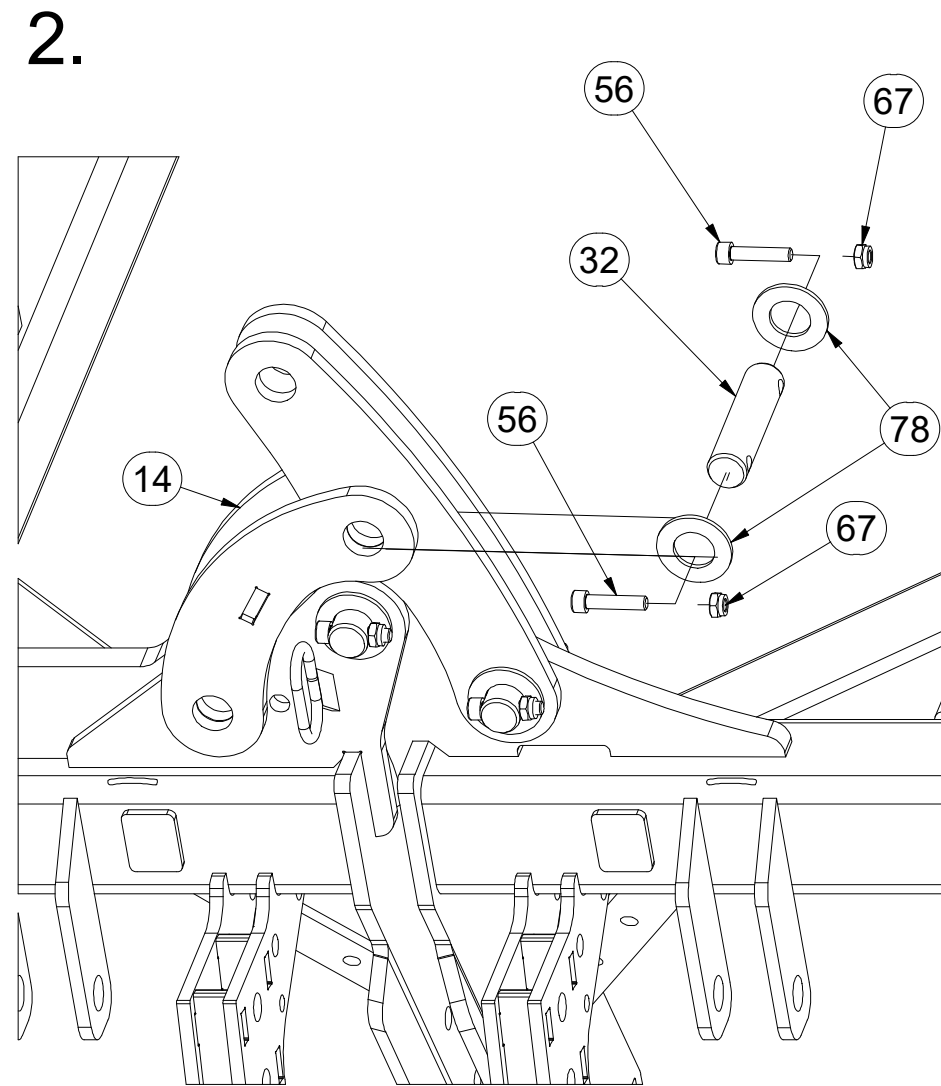
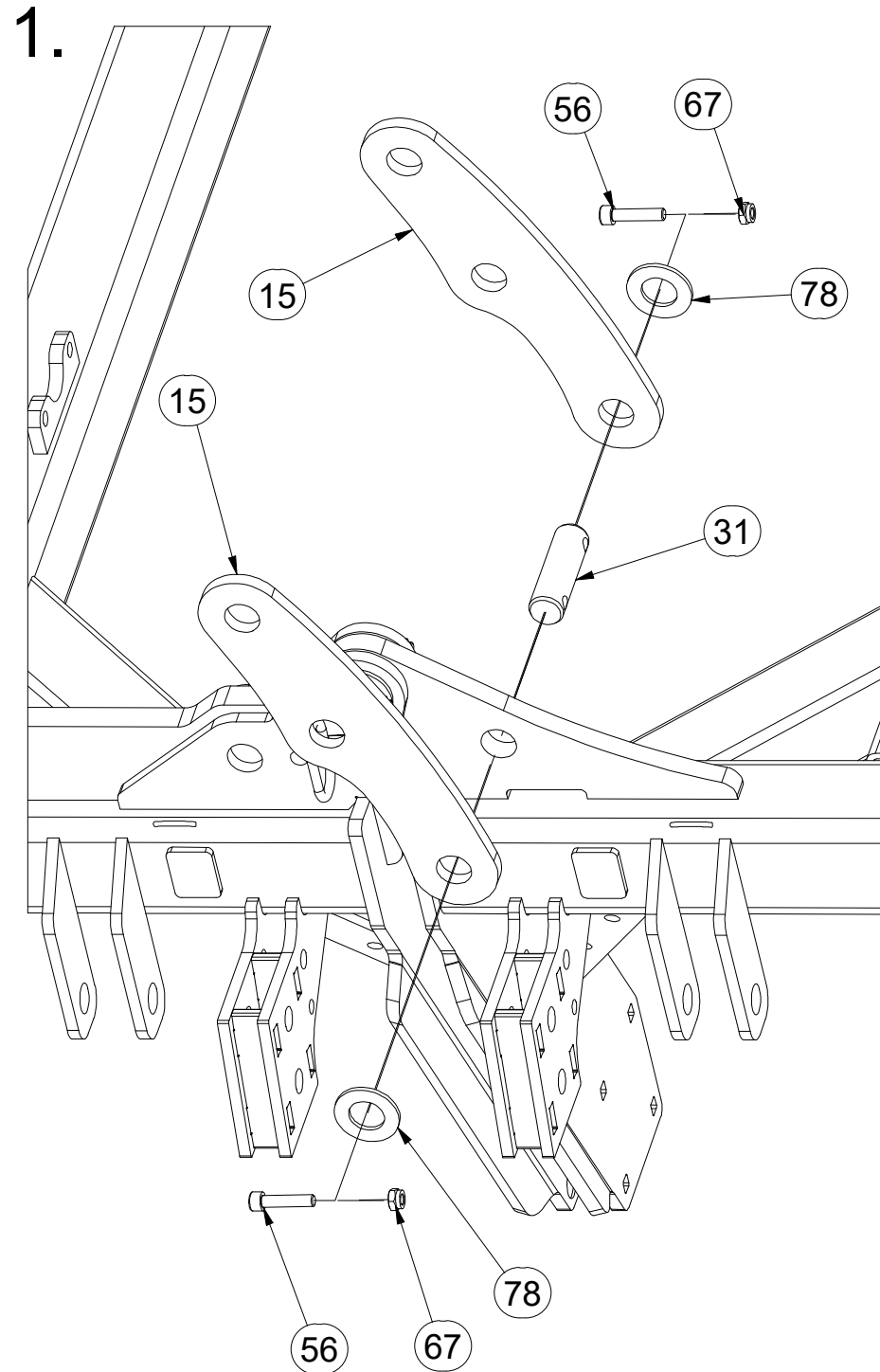

Pos.	Part Number	Pcs.	Pos.	Part Number	Pcs.
4	2000988	1	53	m09870	3
14	3003057	1	56	m14143	54
15	4010308	2	66	m04503	27
22	VZ00023134	1	67	m03775	60
24	VZ00030750	1	77	m14030	3
31	4008234	10	78	m14029	66
32	4011761	3			

☉ POLOTOVAR STROJE

☎ MASCHINEN-HALBFABRIKAT

☏ MACHINE - SEMI-PRODUIT

☉ SEMIFINISHED MACHINE

☎ ПОЛУФАБРИКАТ МАШИНЫ

☏ PÓLFABRYKAT MASZYNY



**3012664**

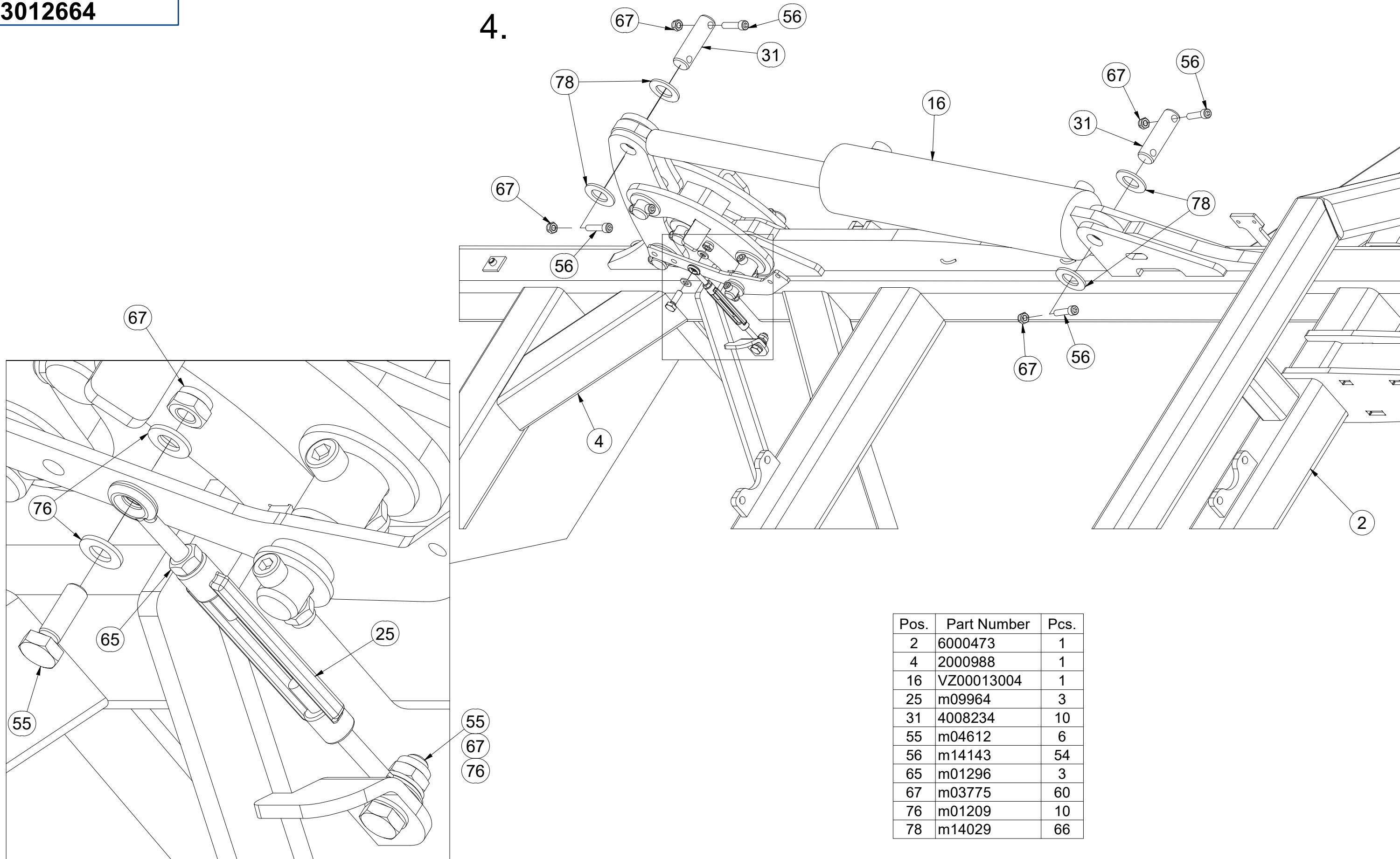

Pos.	Part Number	Pcs.
2	6000473	1
4	2000988	1
16	VZ00013004	1
25	m09964	3
31	4008234	10
55	m04612	6
56	m14143	54
65	m01296	3
67	m03775	60
76	m01209	10
78	m14029	66



☉ SAMOLEPKY STROJE

☉ AUFKLEBER MASCHINEN

☉ VOITURE MACHINES

☉ STICKERS MACHINES

☉ СТИКЕРЫ МАШИНЫ

☉ NAKLEJKI MASZYNY



**m23015**

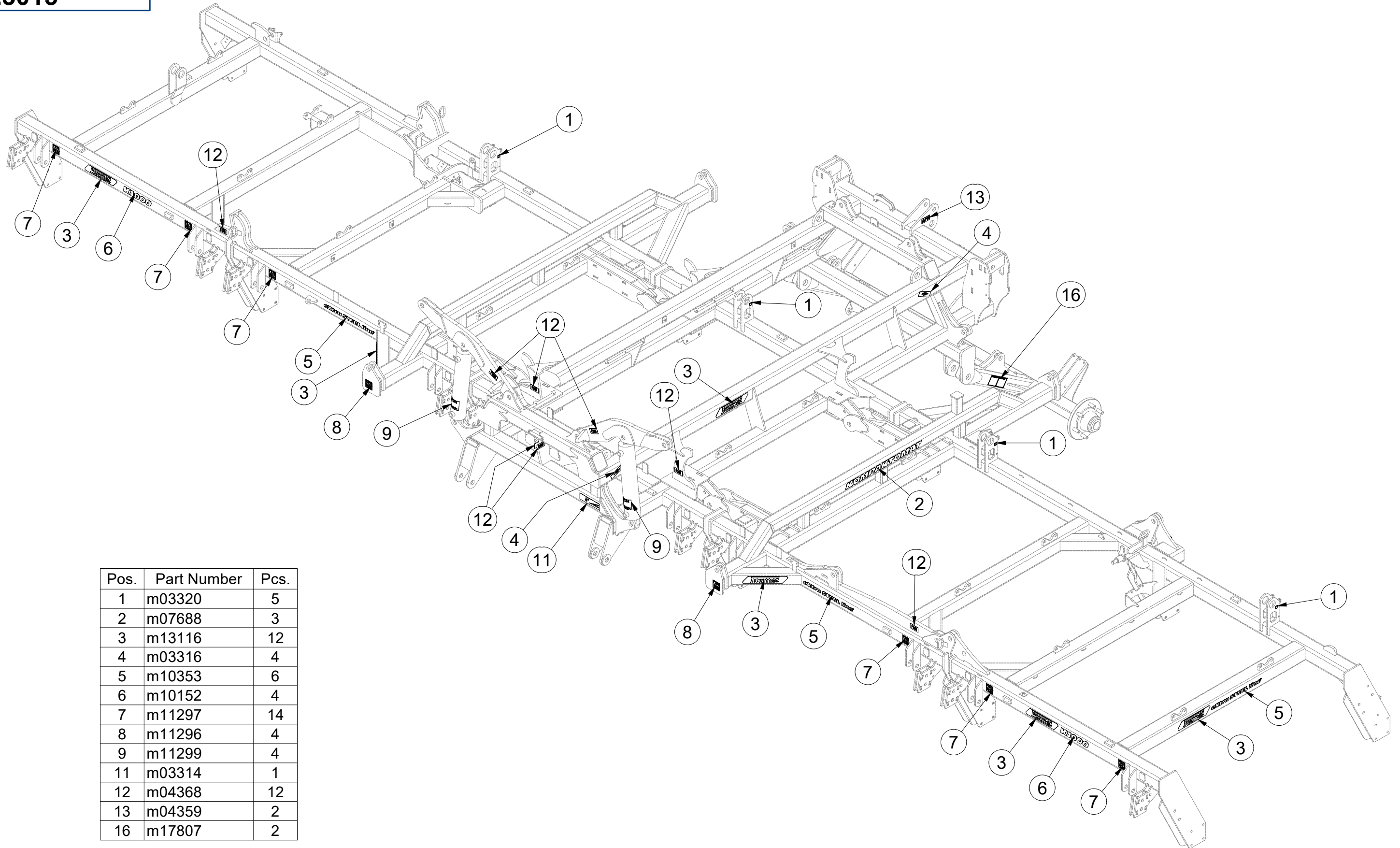

Pos.	Part Number	Pcs.
1	m03320	5
2	m07688	3
3	m13116	12
4	m03316	4
5	m10353	6
6	m10152	4
7	m11297	14
8	m11296	4
9	m11299	4
11	m03314	1
12	m04368	12
13	m04359	2
16	m17807	2

Ⓒ SAMOLEPKY STROJE

Ⓓ AUFKLEBER MASCHINEN

Ⓕ VOITURE MACHINES

Ⓖ STICKERS MACHINES

Ⓔ СТИКЕРЫ МАШИНЫ

Ⓟ NAKLEJKI MASZYNY



**m23015**

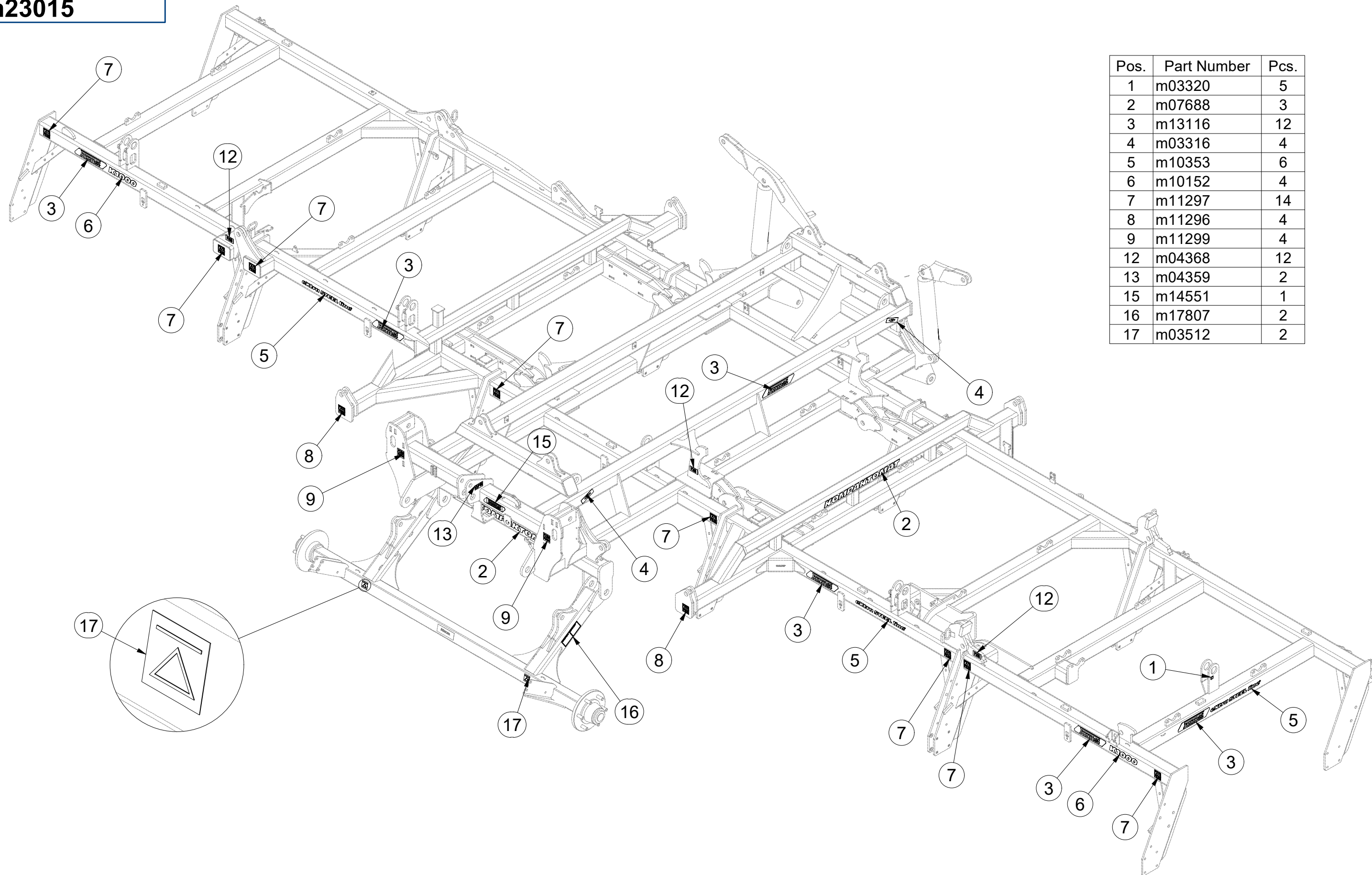

Pos.	Part Number	Pcs.
1	m03320	5
2	m07688	3
3	m13116	12
4	m03316	4
5	m10353	6
6	m10152	4
7	m11297	14
8	m11296	4
9	m11299	4
12	m04368	12
13	m04359	2
15	m14551	1
16	m17807	2
17	m03512	2

CZ NASAZOVACÍ KLIKA  
 D MONTAGEGRIFF  
 F POIGNÉE DE MONTAGE

GB MOUNTING HANDLE  
 RU МОНТАЖНАЯ РУЧКА  
 PL UCHWYT MONTAŻOWY



**4003087**

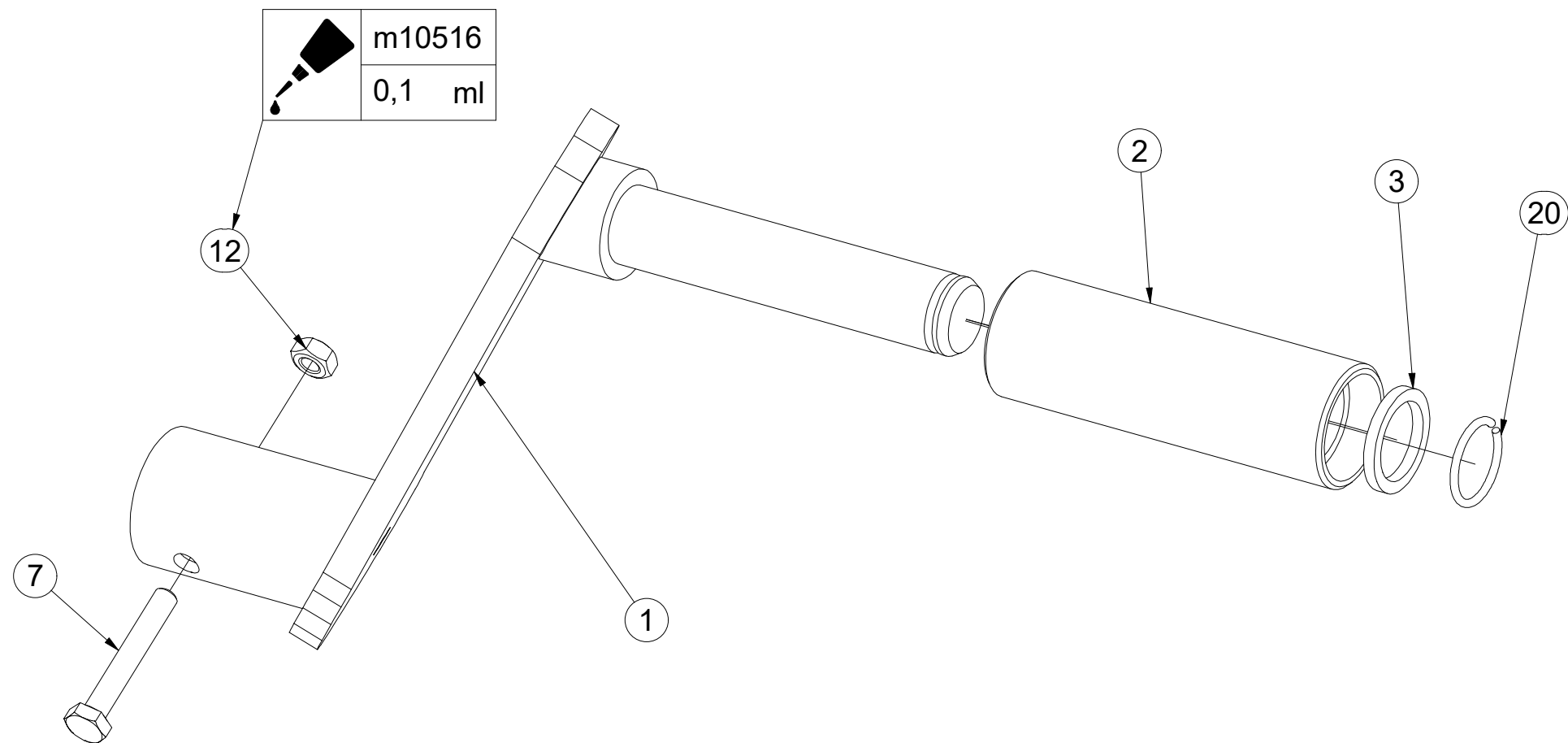
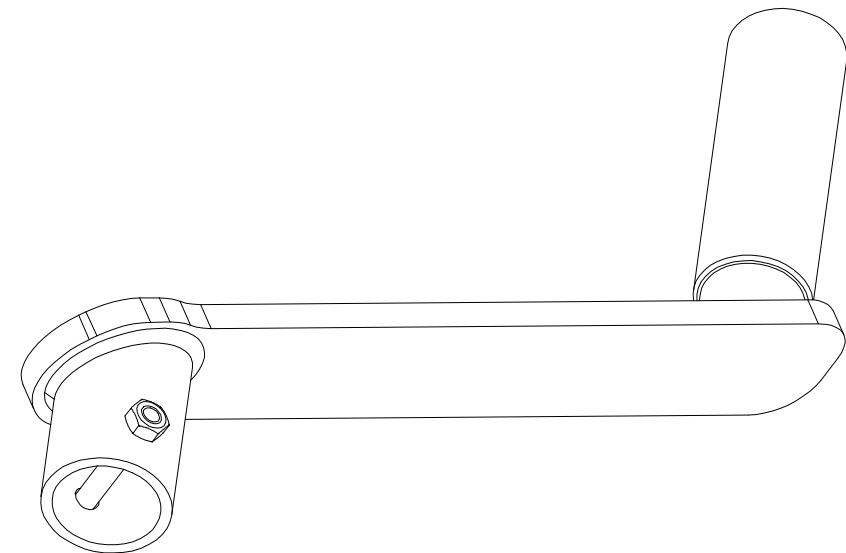

Pos.	Part Number	Pcs.
1	4003092	1
2	4001533	1
3	4004828	1
7	m04641	1
12	m01295	1
20	m06561	1
25	m10516	0,1

ⒸZ TÁHLO SKLÁPĚNÍ

Ⓓ ZUGSTANGE ZUR KIPPUNG

Ⓕ TIGES DE L'ESSIEU

**4005363**

ⒼB TILTING PULL ROD

ⒺU ТЯГИ ТРАНСПОРТНОЙ ОСИ

ⒽL SPRZĘGI OSI

**Farmet**

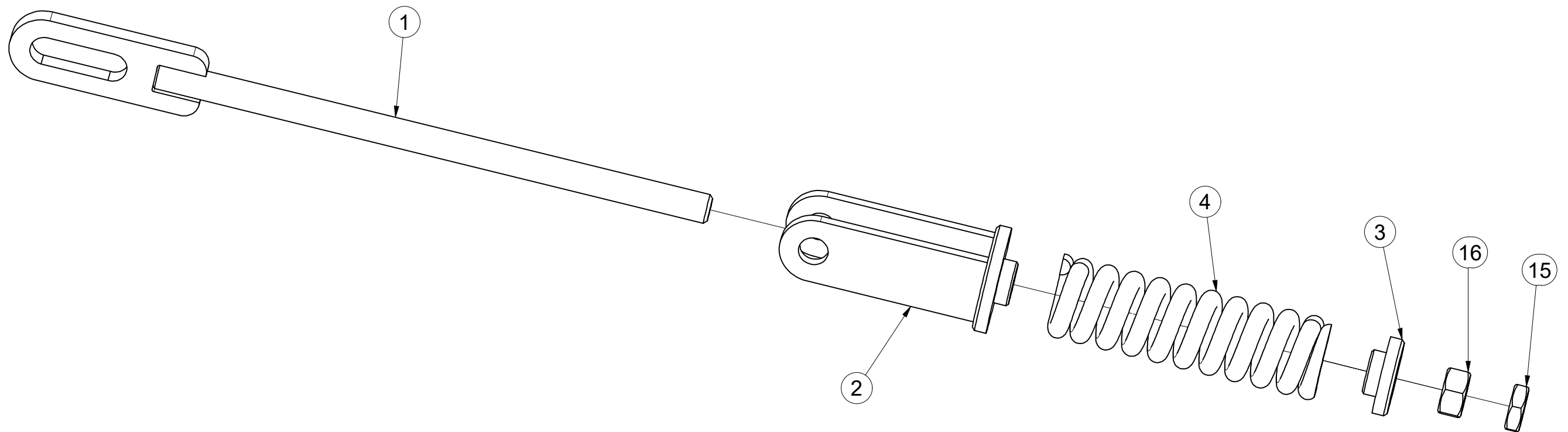
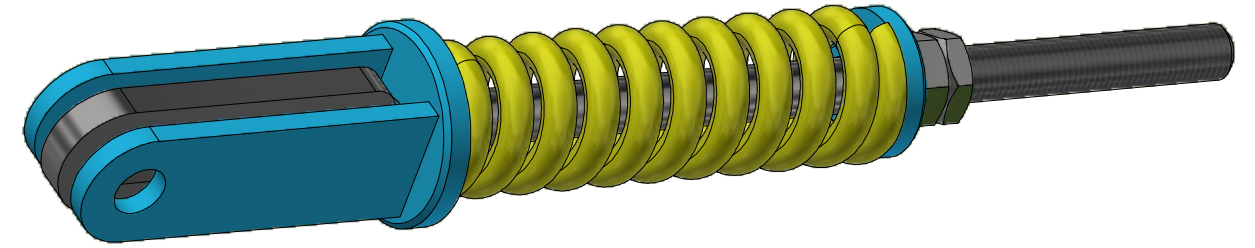

Pos.	Part Number	Pcs.
1	4005358	1
2	4005361	1
3	4000023	1
4	m06482	1
15	m04043	1
16	m01309	1

Ⓒ SADA DORAZŮ  
Ⓓ ANSCHLAGSATZ  
Ⓕ KIT DE BUTÉES

Ⓖ SET OF BAR STOPS  
Ⓔ КОМПЛЕКТ УΠΟΡΟΒ  
Ⓗ ZESTAW DOCISKÓW



**4023085**

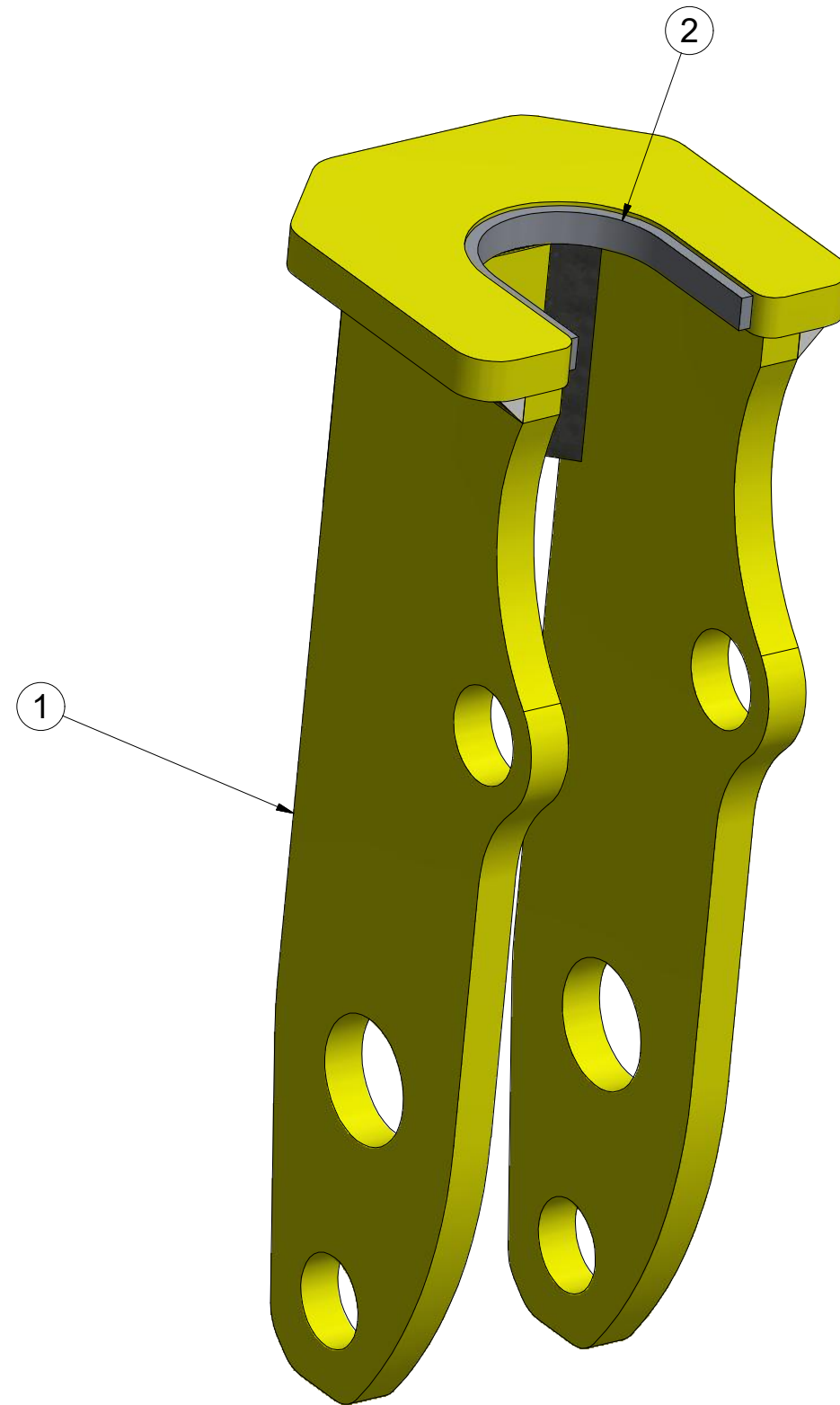

Pos.	Part Number	Pcs.
1	3011373	1
2	m09566	0,18

Ⓒ HYDRAULIKA STROJE

Ⓓ HYDRAULIK DER MASCHINE

Ⓕ HYDRAULIQUE DE LA MACHINE

**VZ00010577**

Ⓖ MACHINE HYDRAULICS

Ⓡ ГИДРАВЛИКА МАШИНЫ

Ⓟ HYDRAULIKA MASZYNY

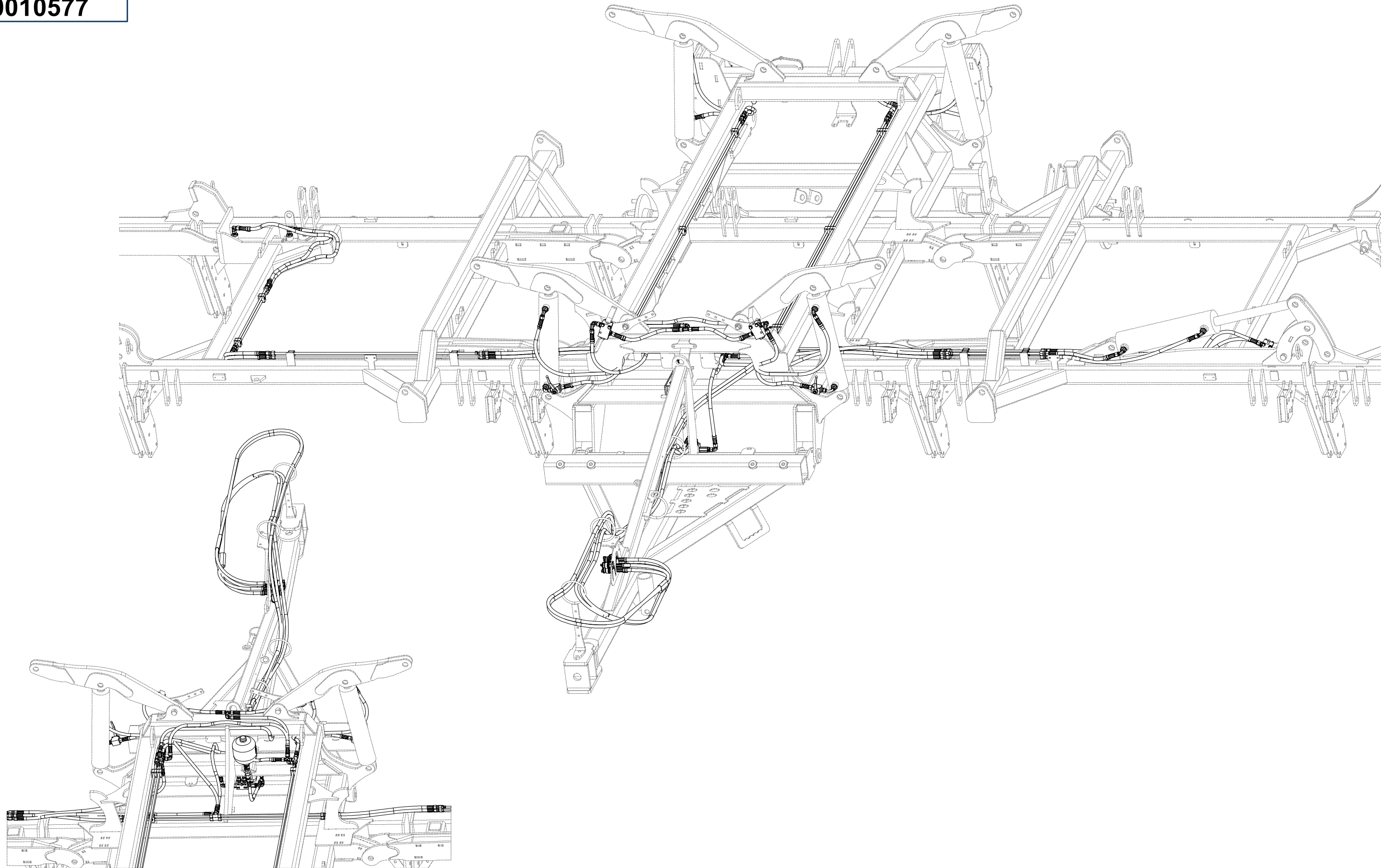

**VZ00010577**

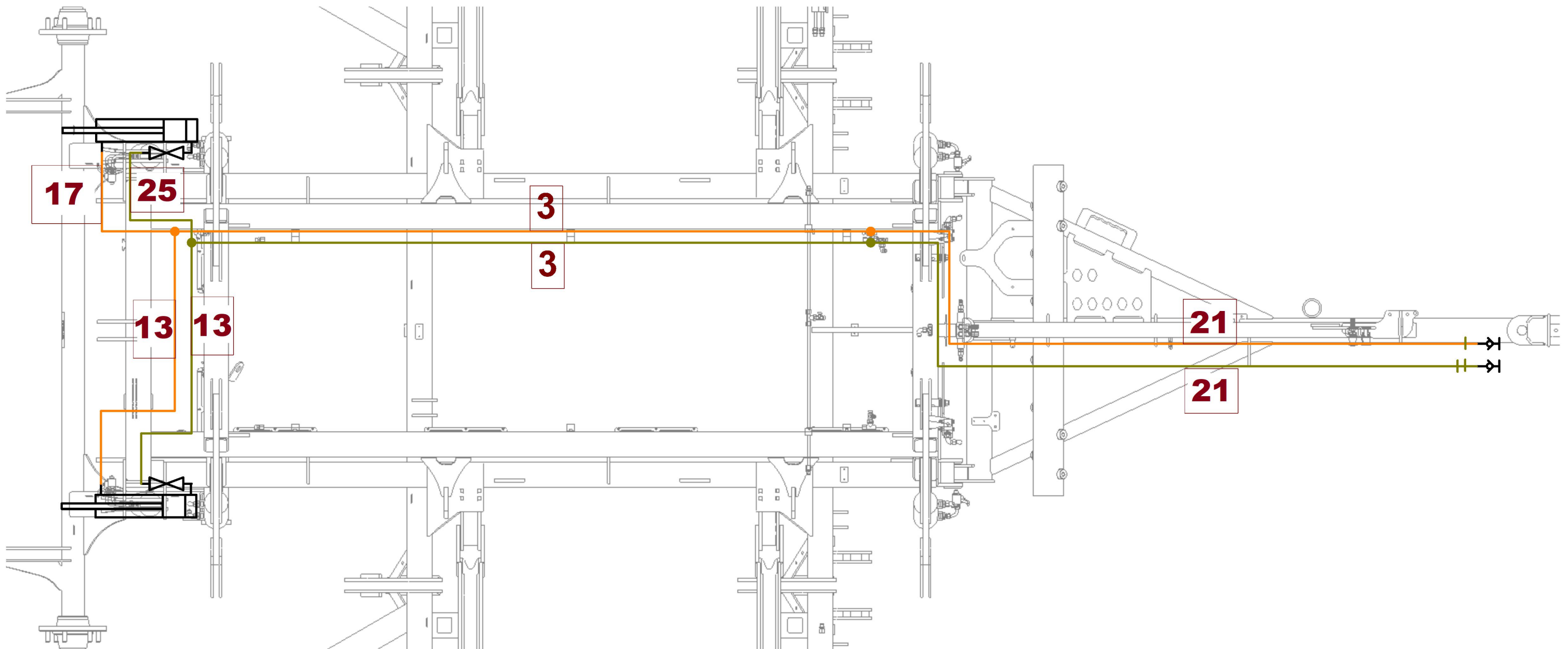

Pos.	Part Number	Pcs.
3	m10056	2
13	m03952	3
17	m09628	2
21	m04752	2
25	m04827	4

Ⓒ HYDRAULIKA STROJE

Ⓓ HYDRAULIK DER MASCHINE

Ⓕ HYDRAULIQUE DE LA MACHINE

Ⓖ MACHINE HYDRAULICS

Ⓡ ГИДРАВЛИКА МАШИНЫ

Ⓟ HYDRAULIKA MASZYN



**VZ00010577**

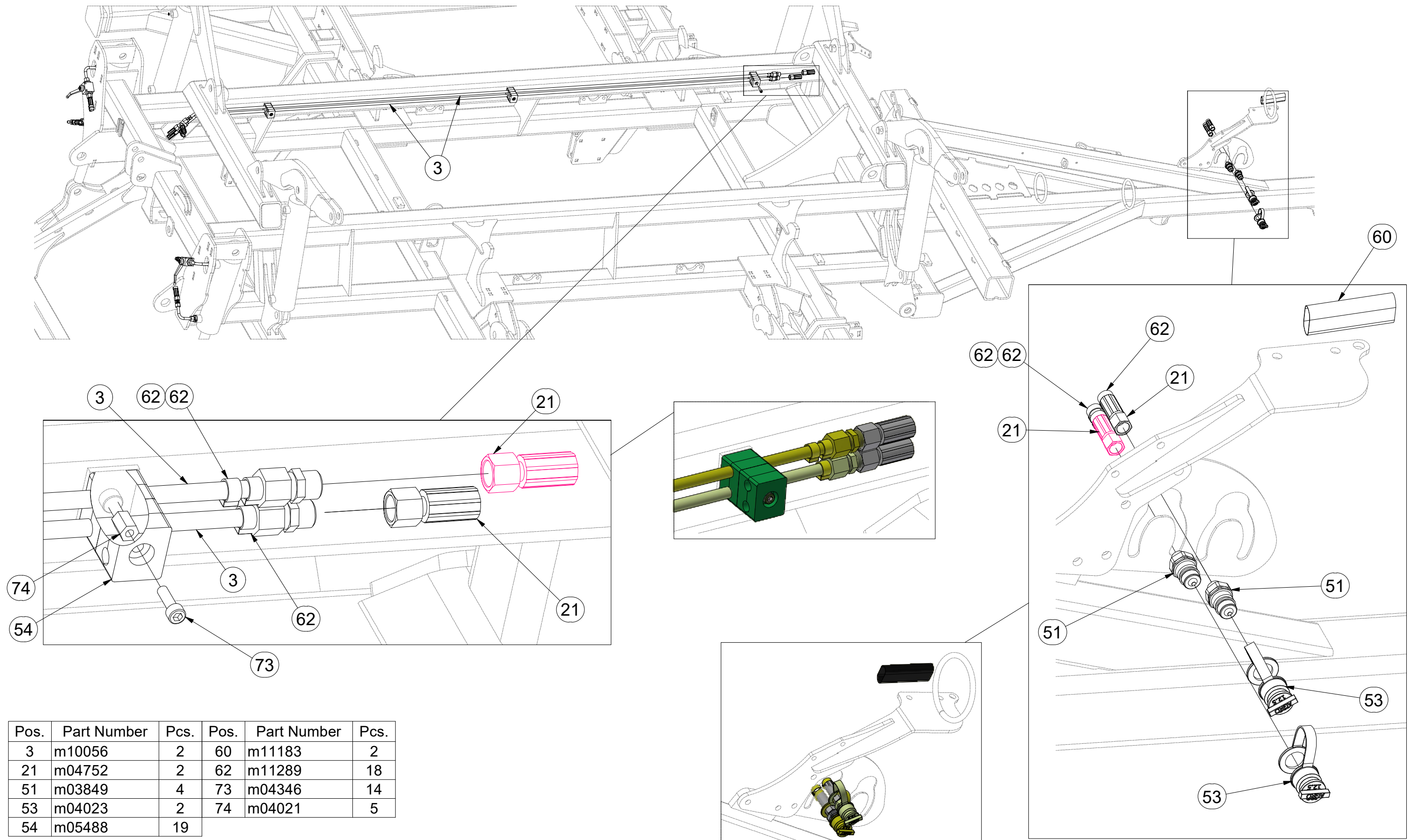



CZ HYDRAULIKA STROJE  
 D HYDRAULIK DER MASCHINE  
 F HYDRAULIQUE DE LA MACHINE

GB MACHINE HYDRAULICS  
 RU ГИДРАВЛИКА МАШИНЫ  
 PL HYDRAULIKA MASZYNY



**VZ00010577**

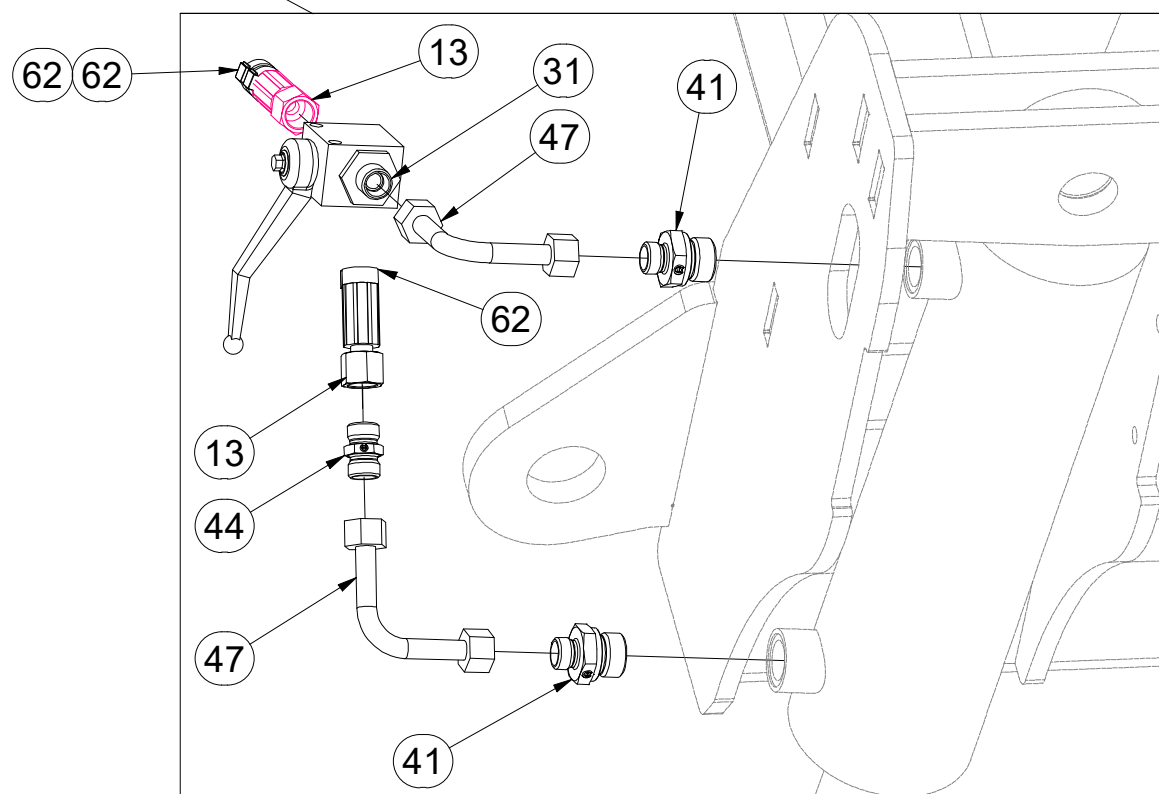
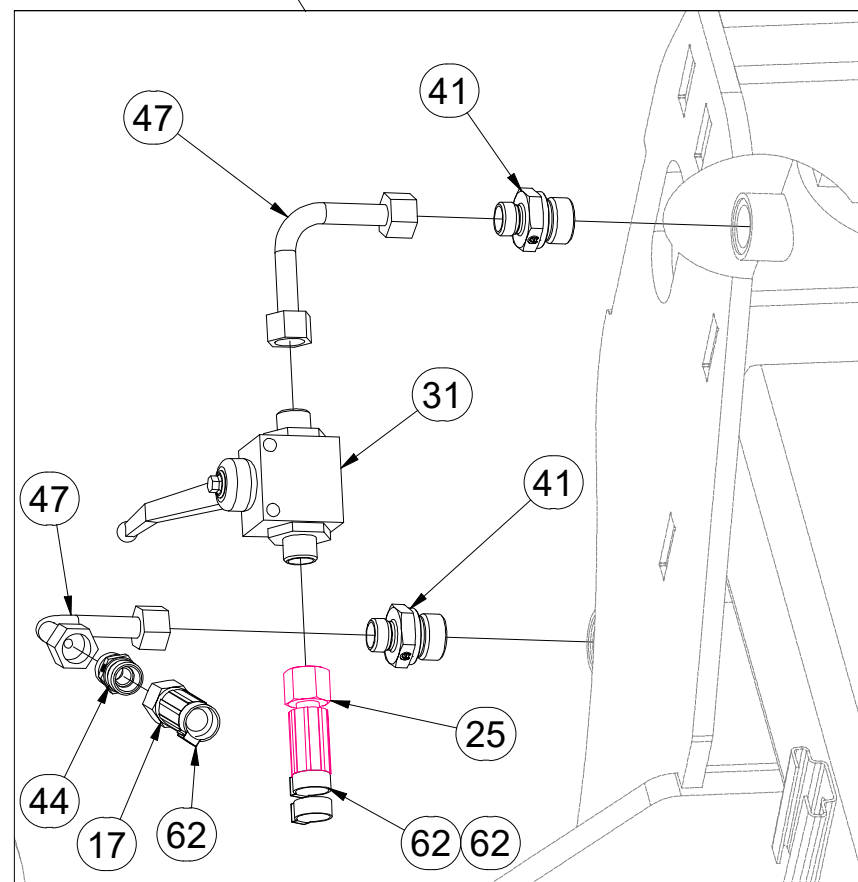
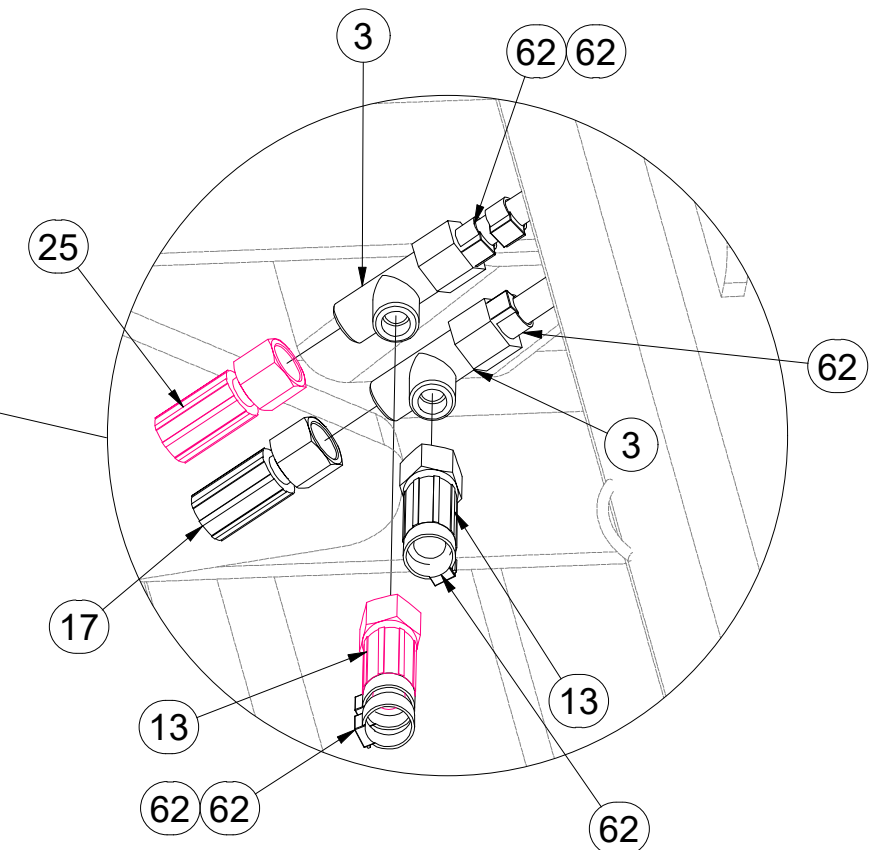
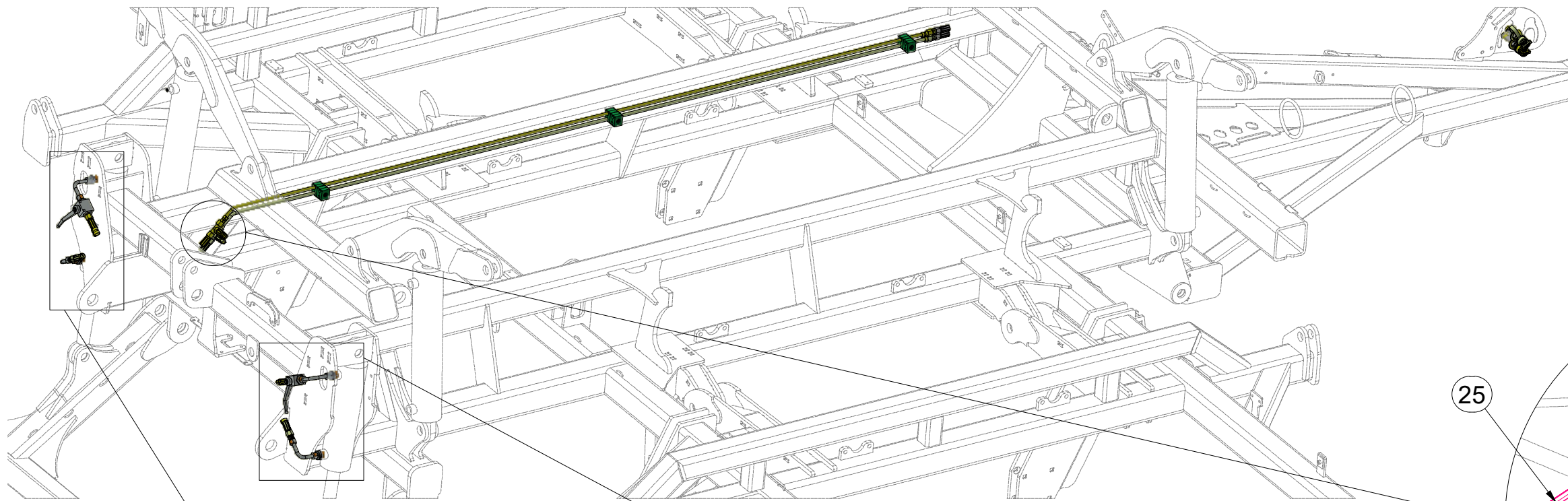

Pos.	Part Number	Pcs.
3	m10056	2
13	m03952	3
17	m09628	2
25	m04827	4
31	m04623	4
41	m09934	16
44	m03213	2
47	m10493	4
62	m11289	18

**VZ00010577**

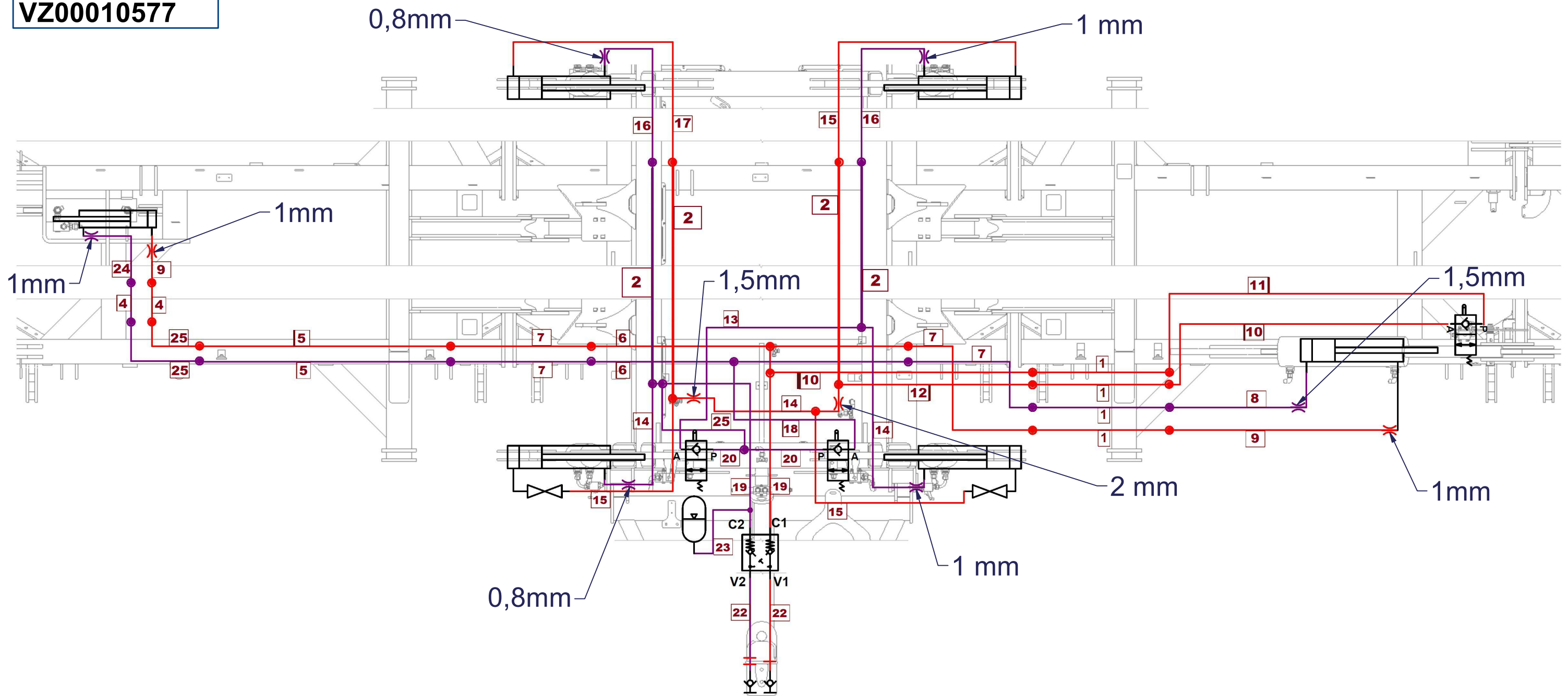

Pos.	Part Number	Pcs.	Pos.	Part Number	Pcs.	Pos.	Part Number	Pcs.
1	m10051	4	11	m07504	1	20	m18212	2
2	m10055	4	12	m03951	1	22	m04087	2
4	m10052	2	13	m03952	3	23	m11000	1
5	m10053	2	14	m06532	3	24	m17041	1
6	m10054	2	15	m04761	3	25	m04827	4
7	m03713	4	16	m04033	2	36	m10779	2
8	m11126	1	17	m09628	2	37	m10780	5
9	m07364	2	18	m04669	1	38	m10777	1
10	m05210	2	19	m07646	2	39	m10781	2

ⒸZ HYDRAULIKA STROJE

Ⓓ HYDRAULIK DER MASCHINE

Ⓕ HYDRAULIQUE DE LA MACHINE

ⒸB MACHINE HYDRAULICS

ⒸR ГИДРАВЛИКА МАШИНЫ

ⒸL HYDRAULIKA MASZYNY



**VZ00010577**

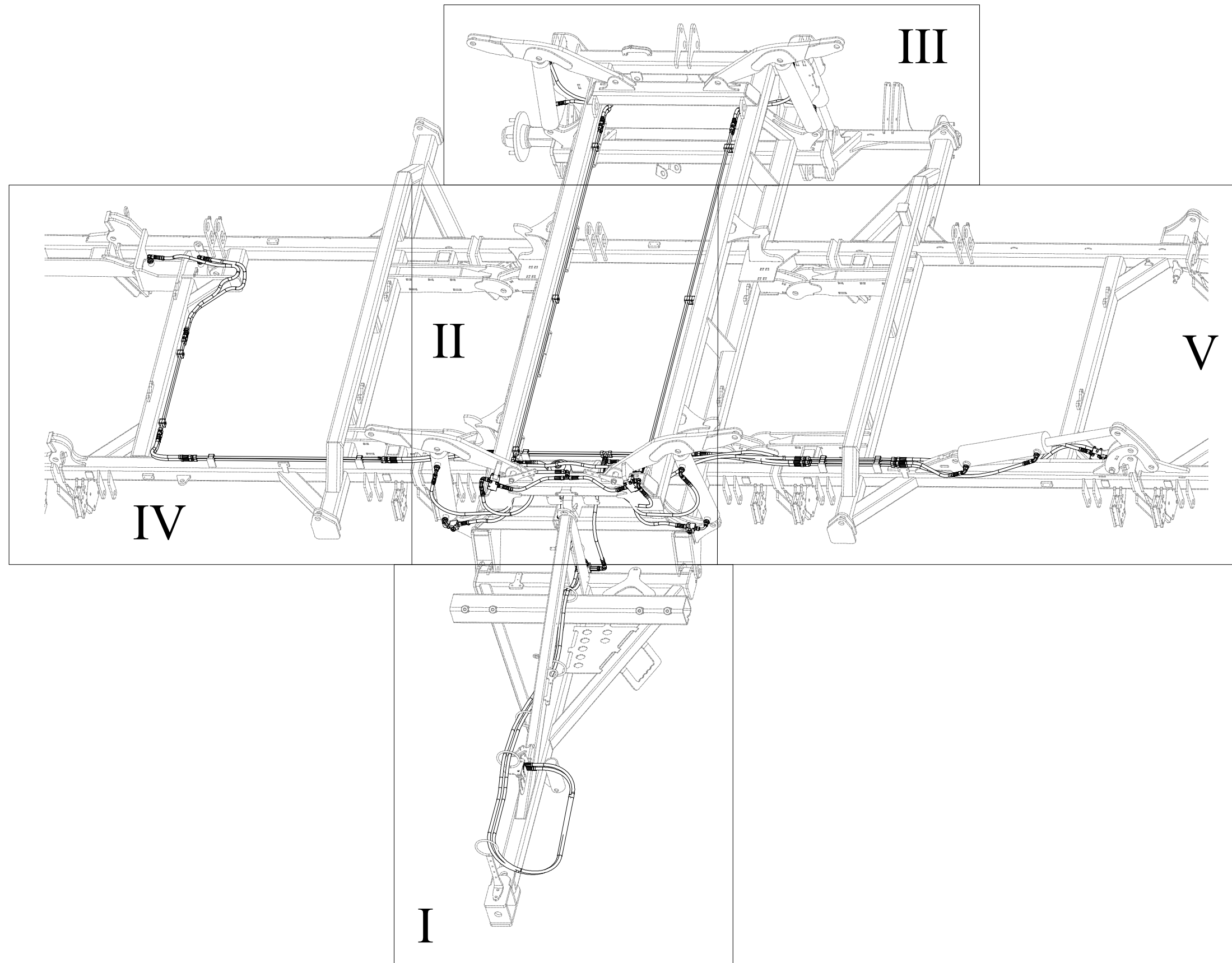

ⒸZ HYDRAULIKA STROJE

Ⓓ HYDRAULIK DER MASCHINE

Ⓕ HYDRAULIQUE DE LA MACHINE

ⒸB MACHINE HYDRAULICS

ⒸR ГИДРАВЛИКА МАШИНЫ

ⒸL HYDRAULIKA MASZYN



II

VZ00010577

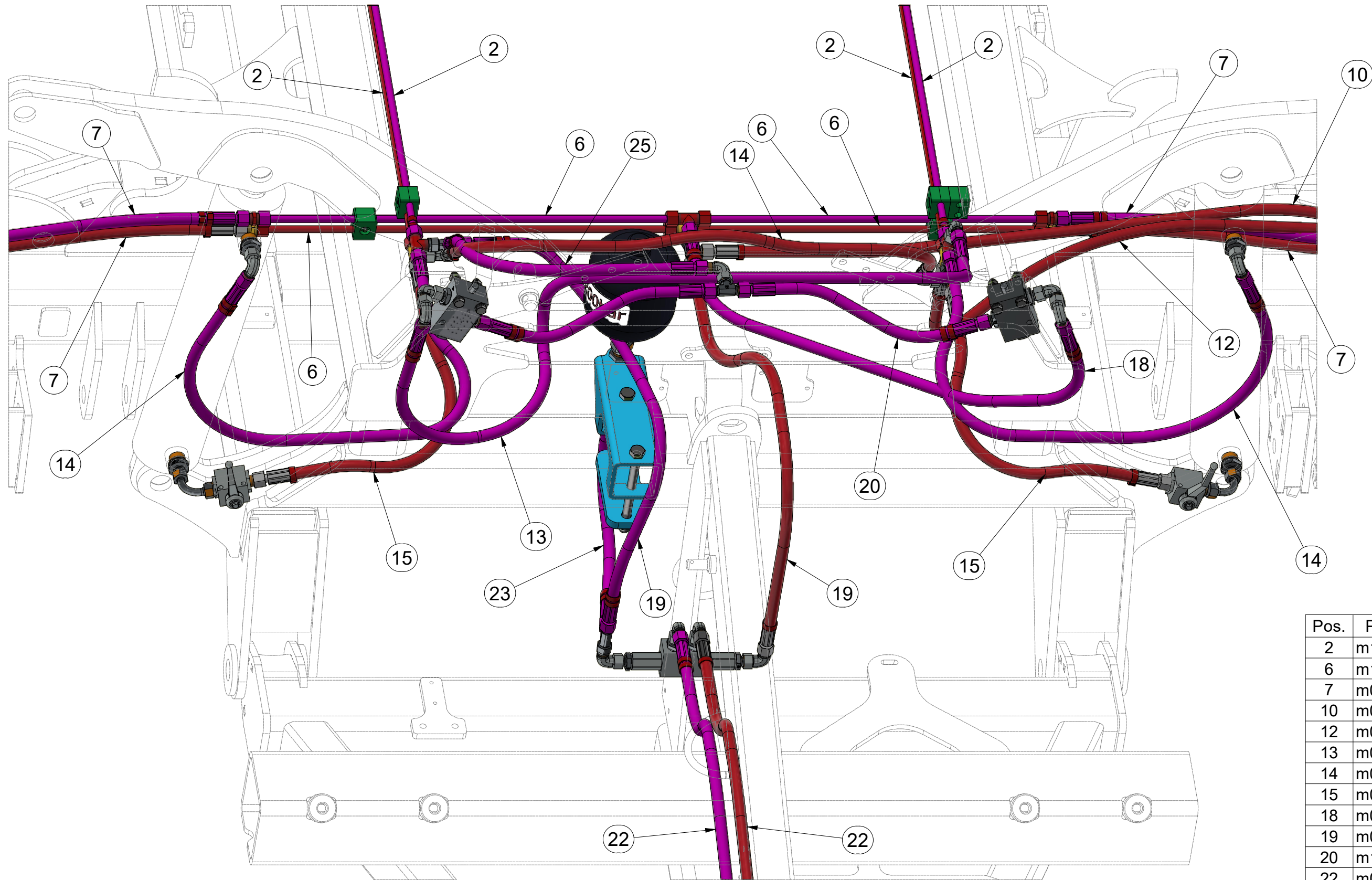

Pos.	Part Number	Pcs.
2	m10055	4
6	m10054	2
7	m03713	4
10	m05210	2
12	m03951	1
13	m03952	3
14	m06532	3
15	m04761	3
18	m04669	1
19	m07646	2
20	m18212	2
22	m04087	2
23	m11000	1
25	m04827	4

**VZ00010577**

II  
Q

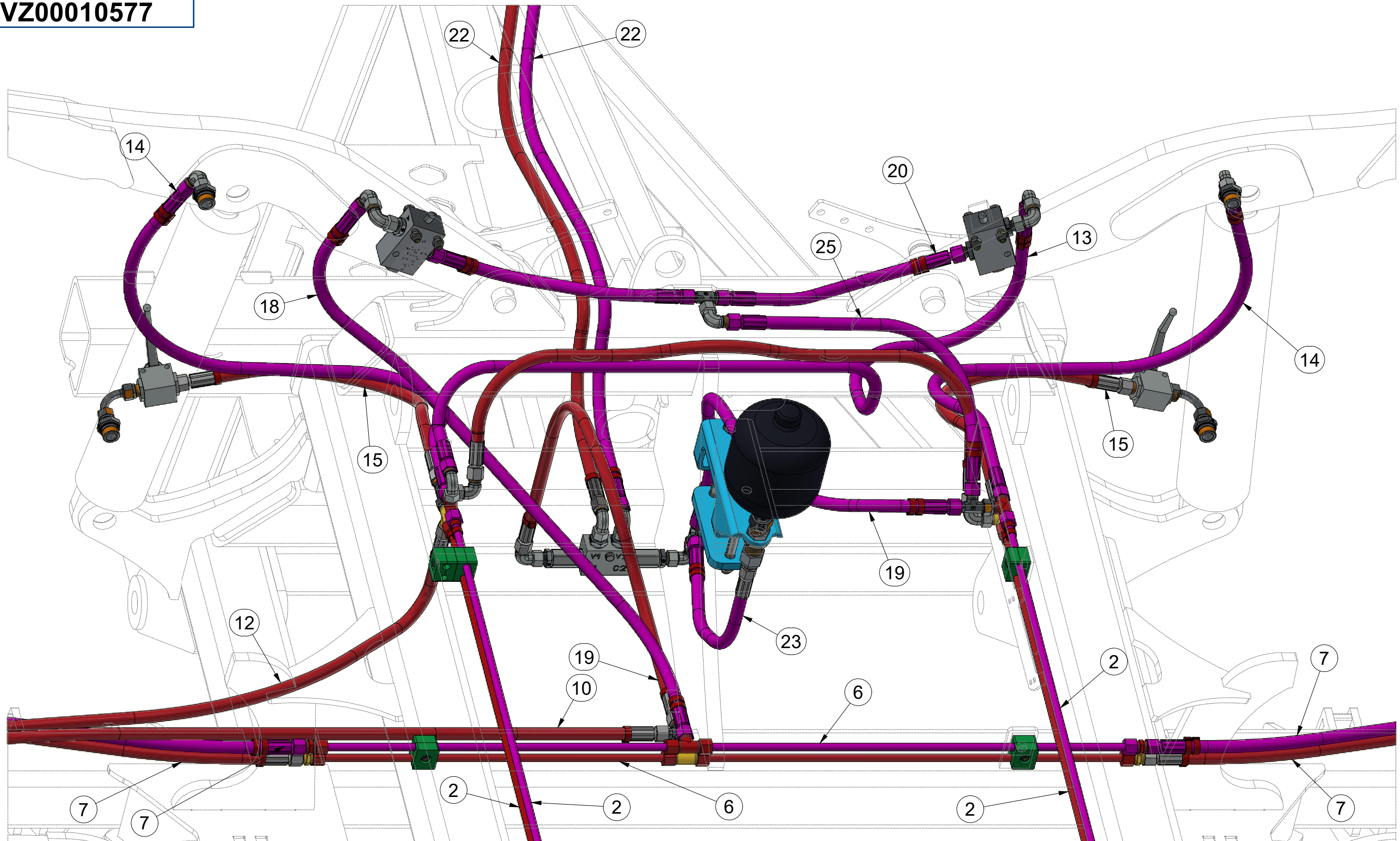

Pos.	Part Number	Pcs.	Pos.	Part Number	Pcs.	Pos.	Part Number	Pcs.	Pos.	Part Number	Pcs.	Pos.	Part Number	Pcs.
2	m10055	4	10	m05210	2	14	m06532	3	19	m07646	2	23	m11000	1
6	m10054	2	12	m03951	1	15	m04761	3	20	m18212	2	25	m04827	4
7	m03713	4	13	m03952	3	18	m04669	1	22	m04087	2			

Ⓒ HYDRAULIKA STROJE

Ⓓ HYDRAULIK DER MASCHINE

Ⓕ HYDRAULIQUE DE LA MACHINE

Ⓖ MACHINE HYDRAULICS

Ⓡ ГИДРАВЛИКА МАШИНЫ

Ⓟ HYDRAULIKA MASZYN



**VZ00010577**

I

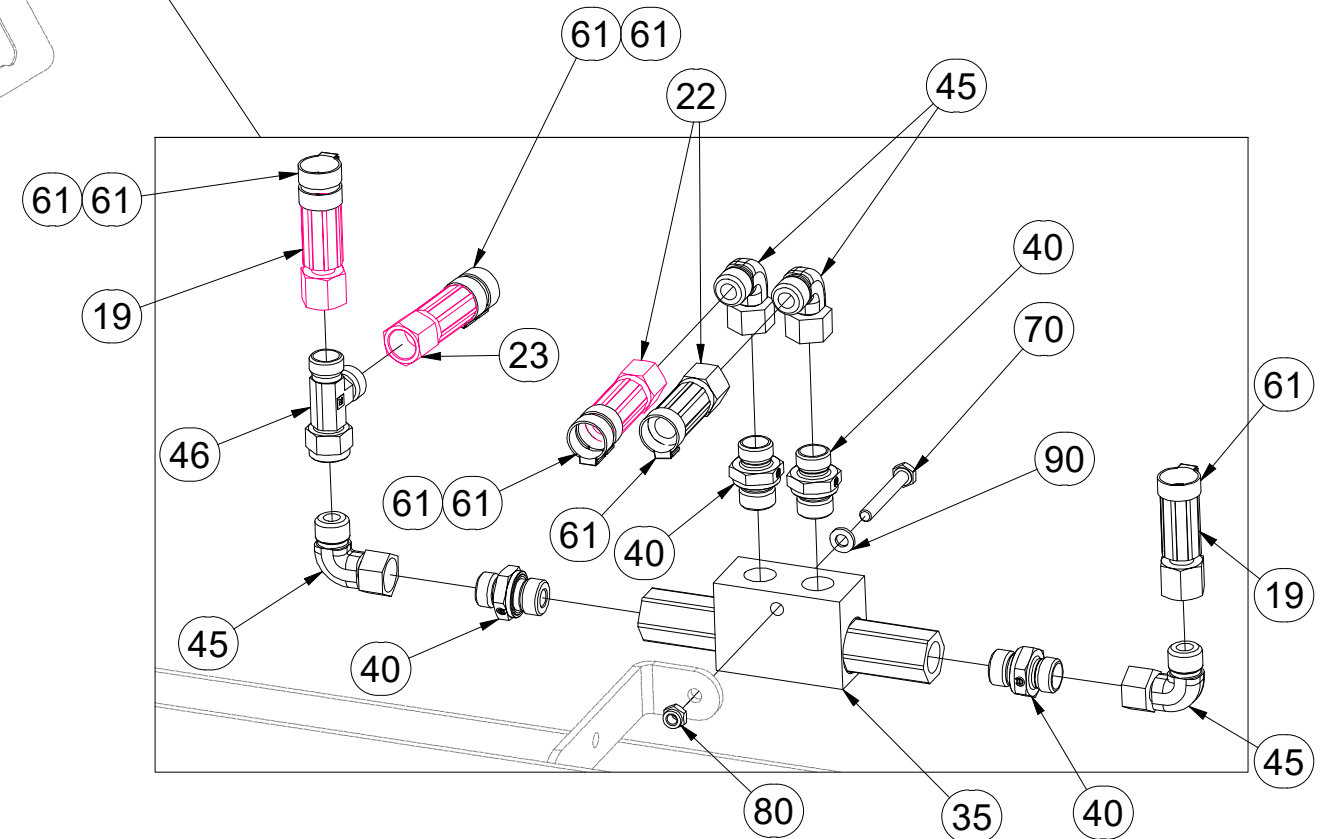
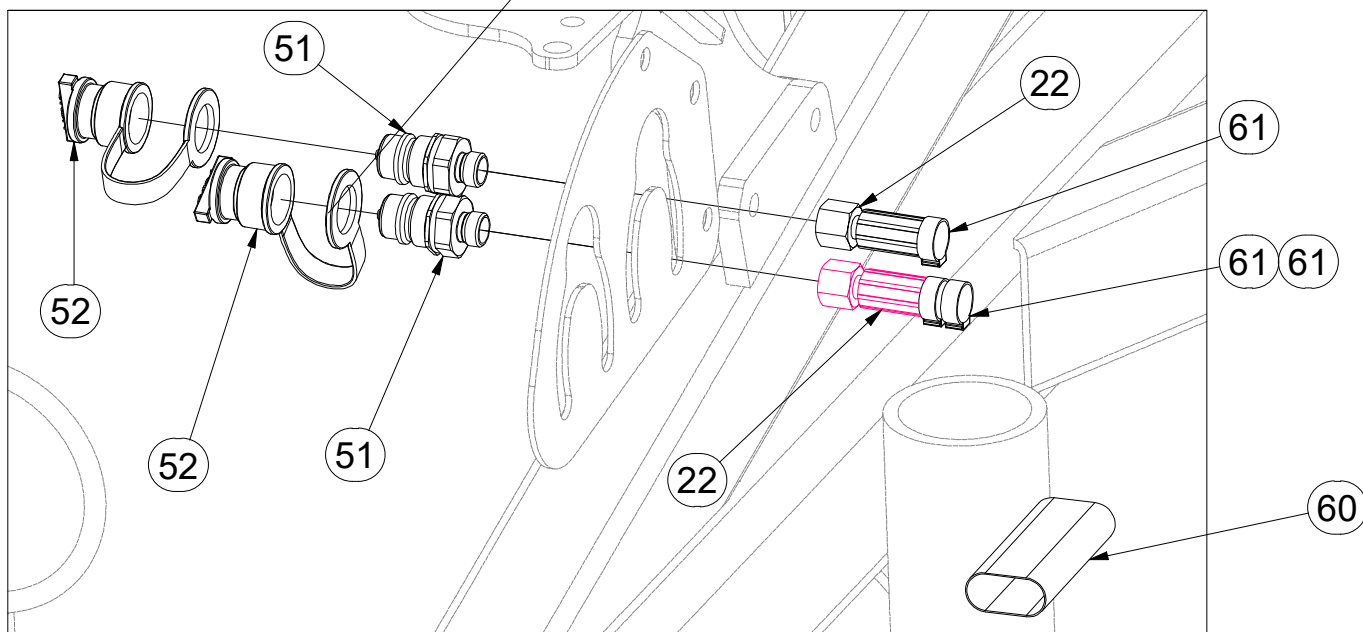
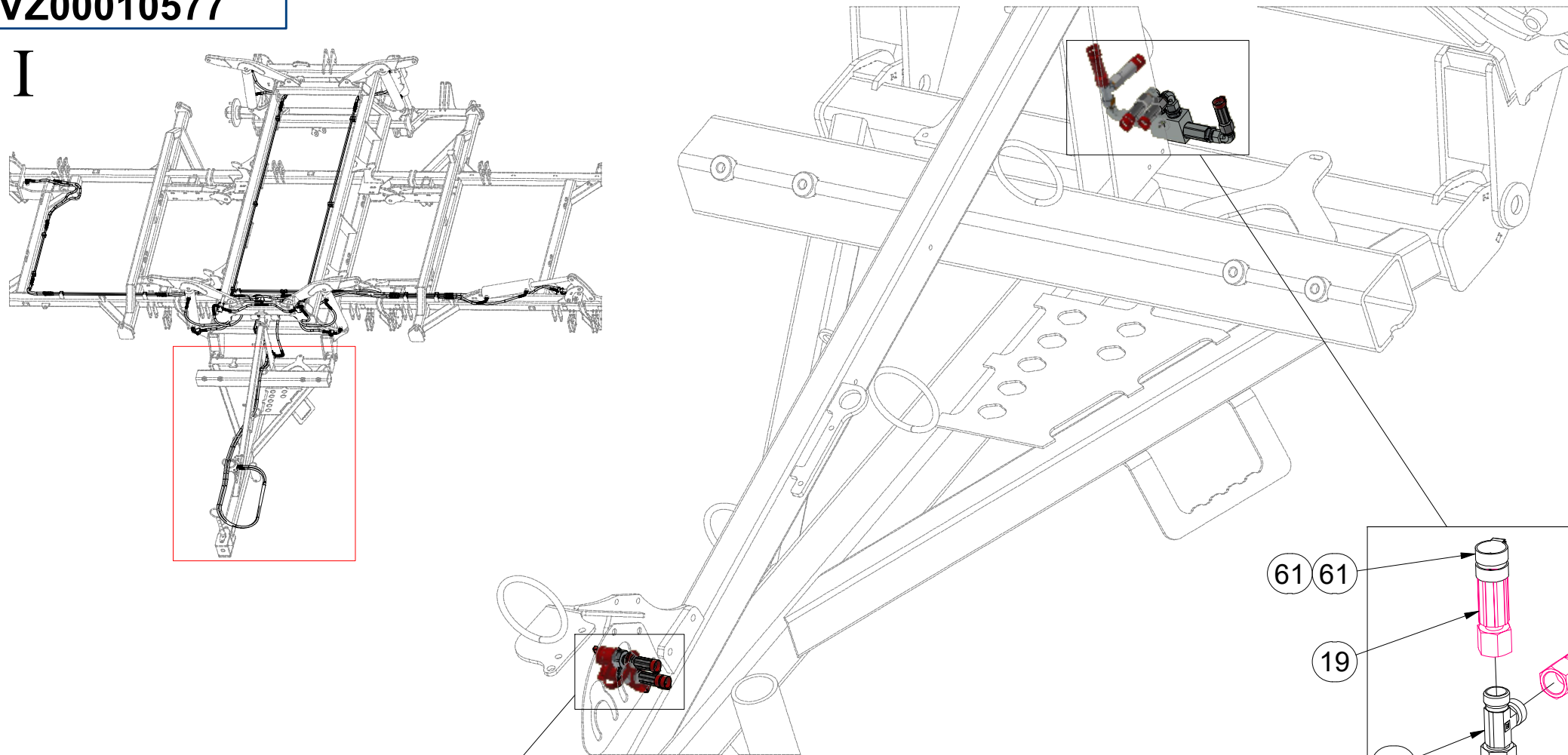

Pos.	Part Number	Pcs.	Pos.	Part Number	Pcs.
19	m07646	2	51	m03849	4
22	m04087	2	52	m04022	2
23	m11000	1	60	m11183	2
35	m06673	1	61	m11294	81
40	m06528	10	70	m05561	1
45	m06803	24	80	m05560	1
46	m07568	4	90	m01199	1

**VZ00010577**

**II**

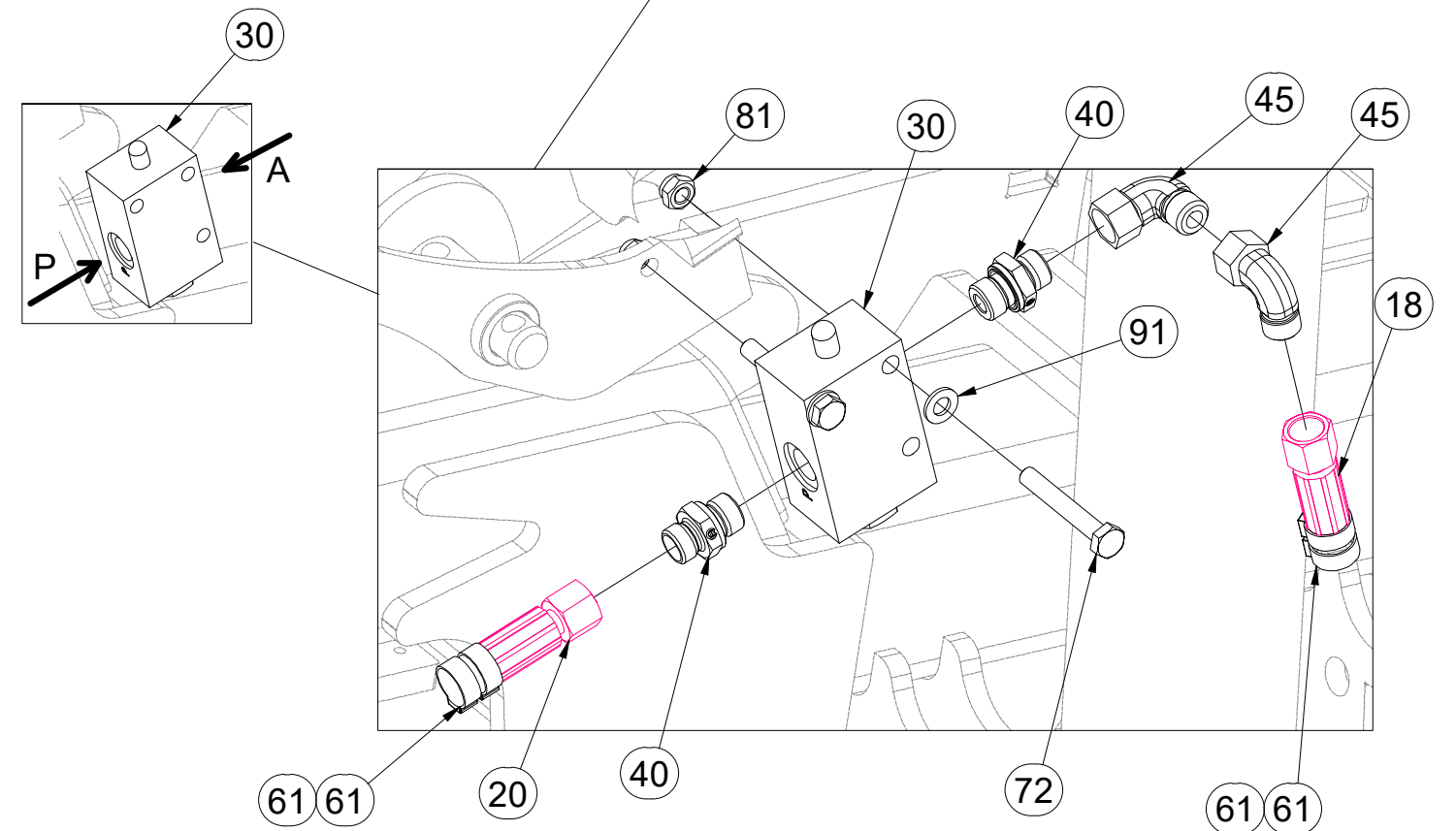
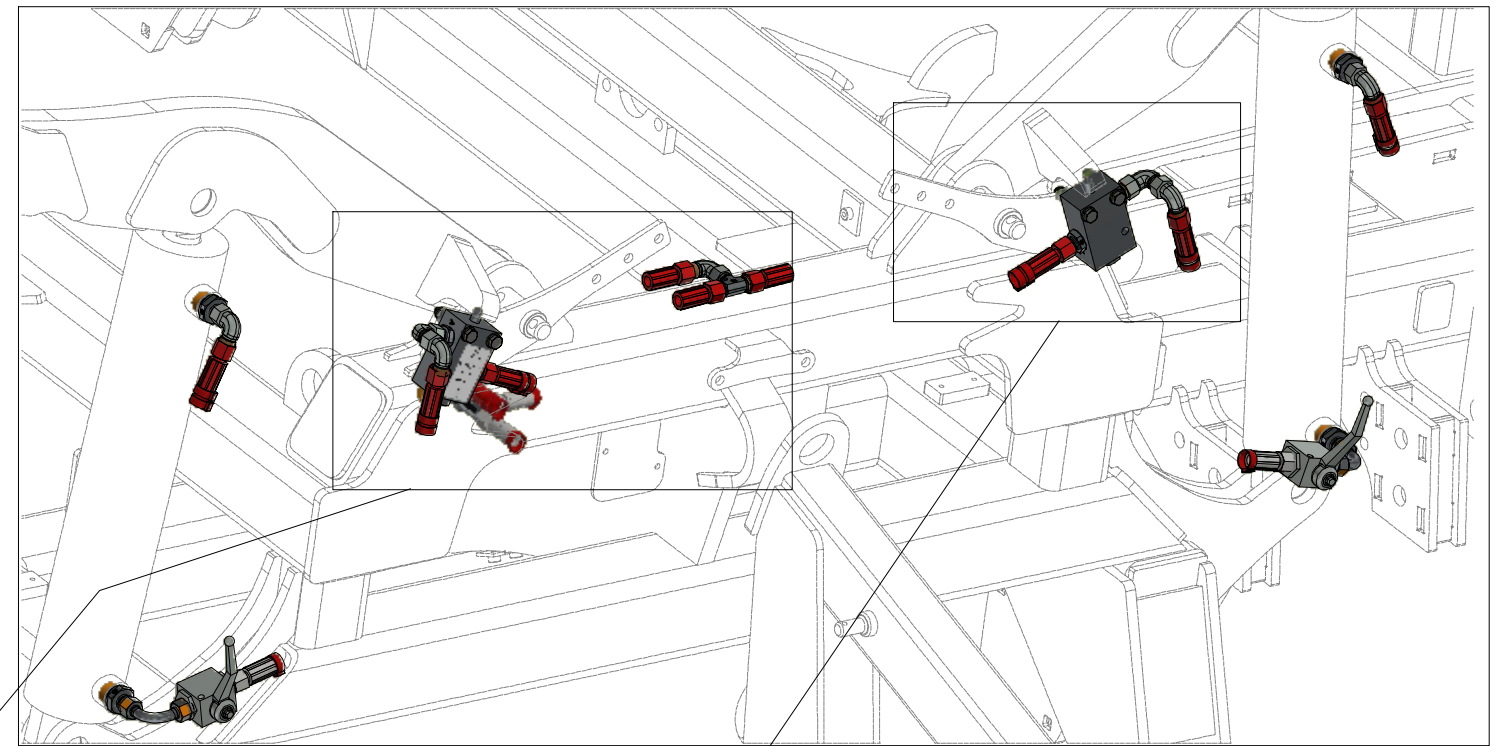
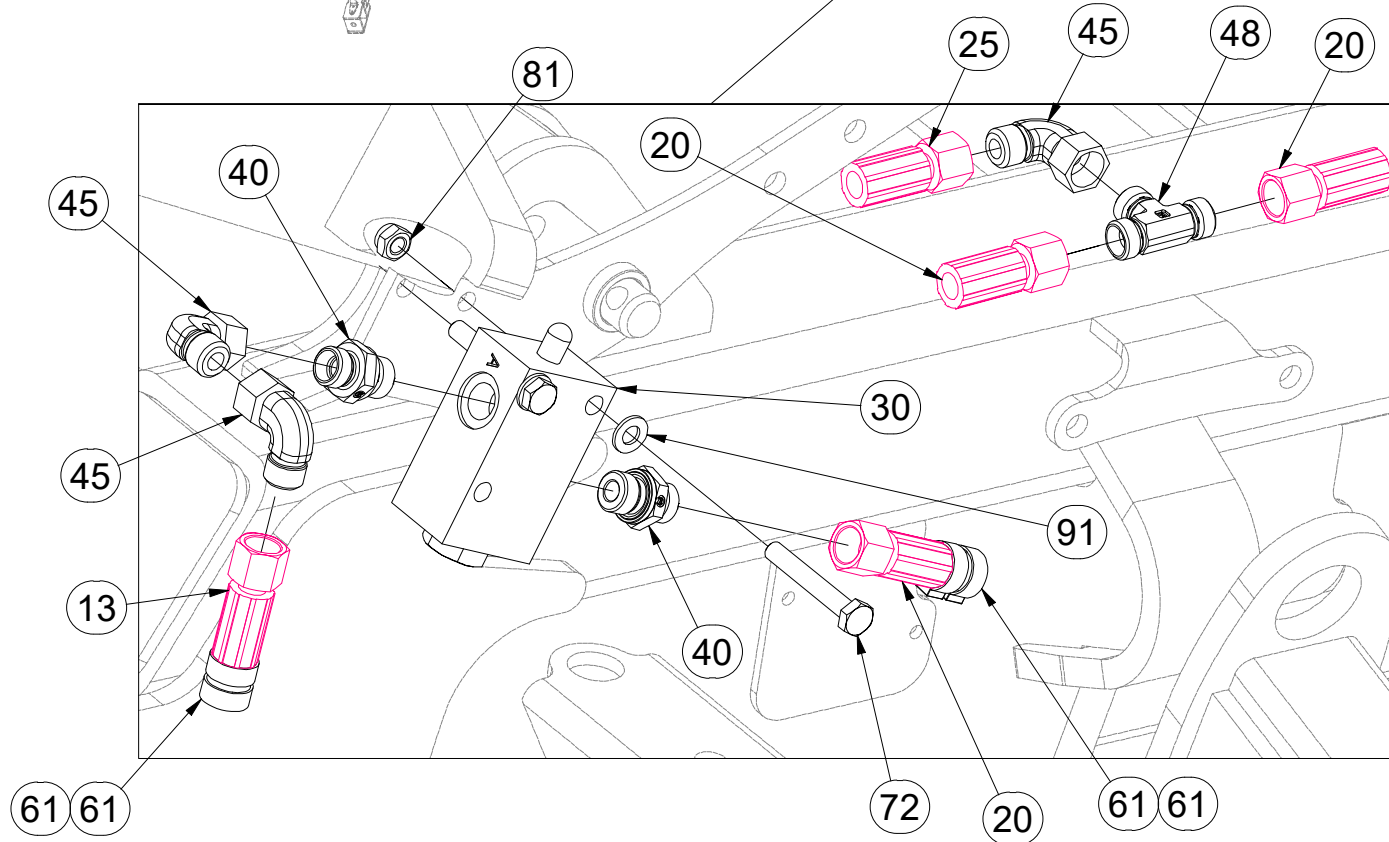
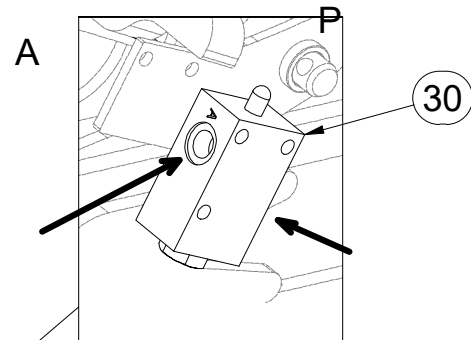
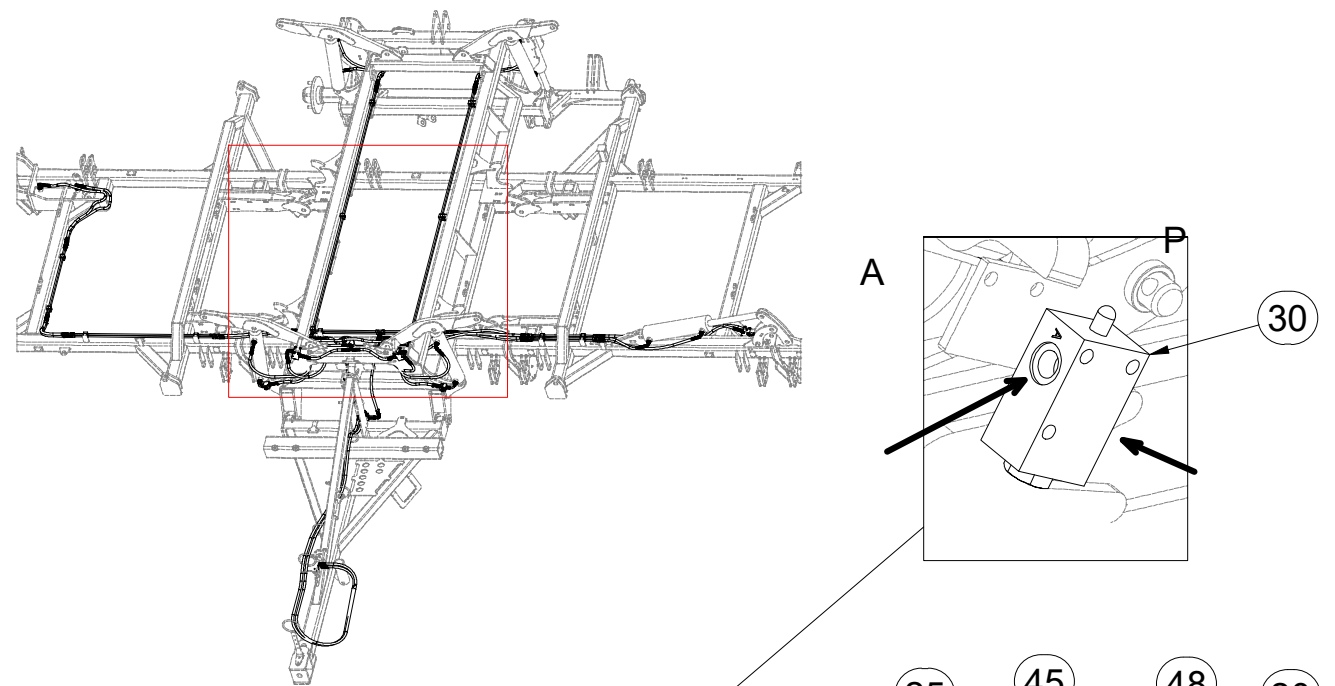

Pos.	Part Number	Pcs.	Pos.	Part Number	Pcs.	Pos.	Part Number	Pcs.
13	m03952	3	30	m10261	3	61	m11294	81
18	m04669	1	40	m06528	10	72	m10593	6
20	m18212	2	45	m06803	24	81	m04503	6
25	m04827	4	48	m03889	1	91	m01203	6

VZ00010577

II

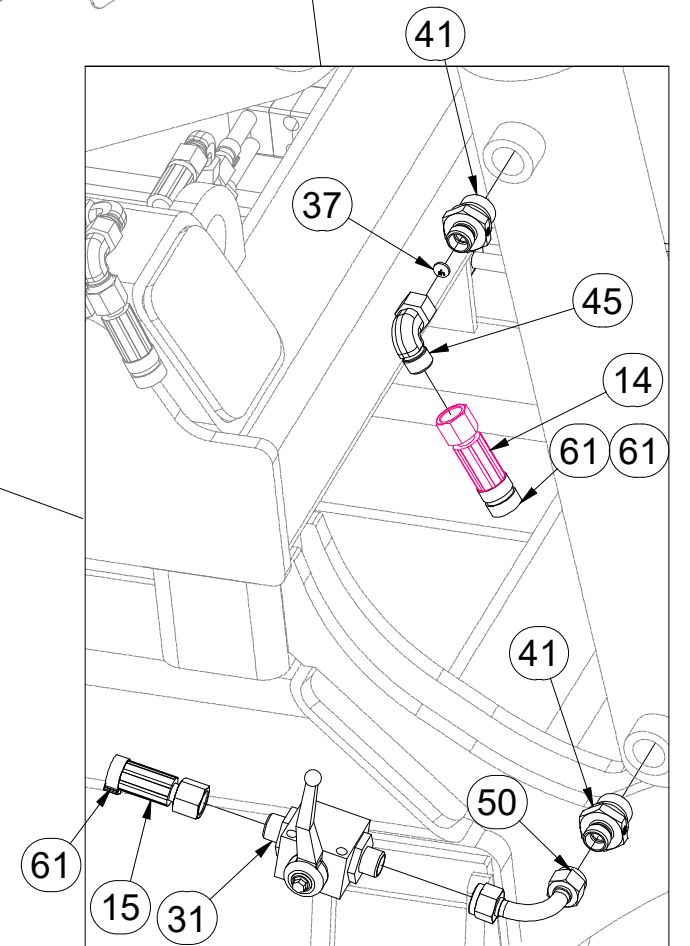
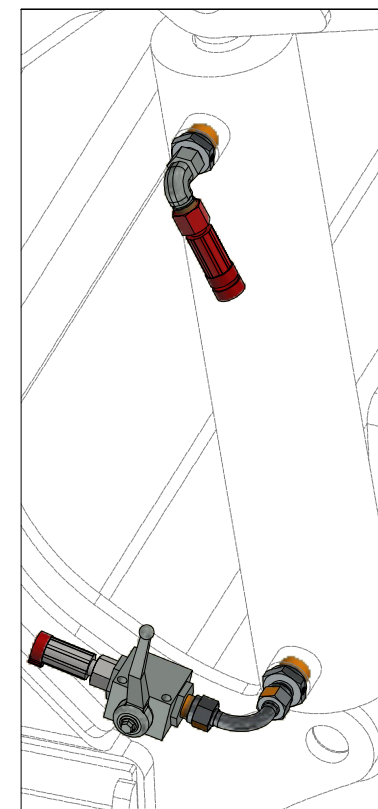
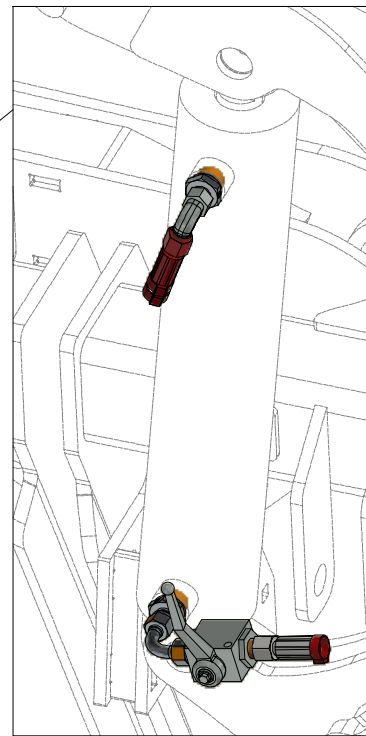
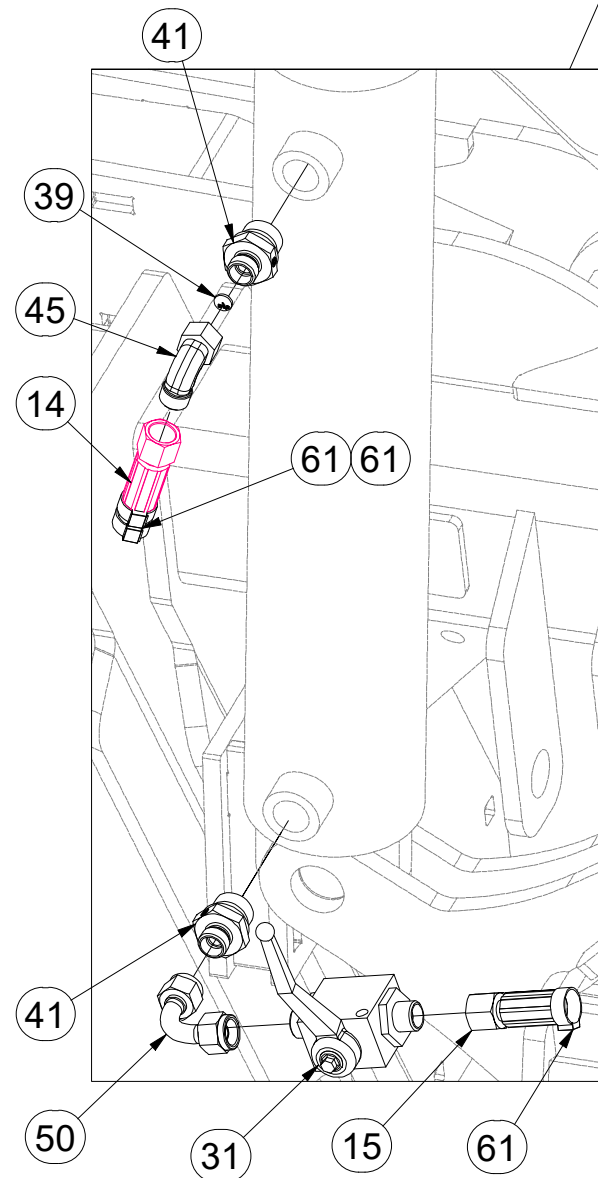
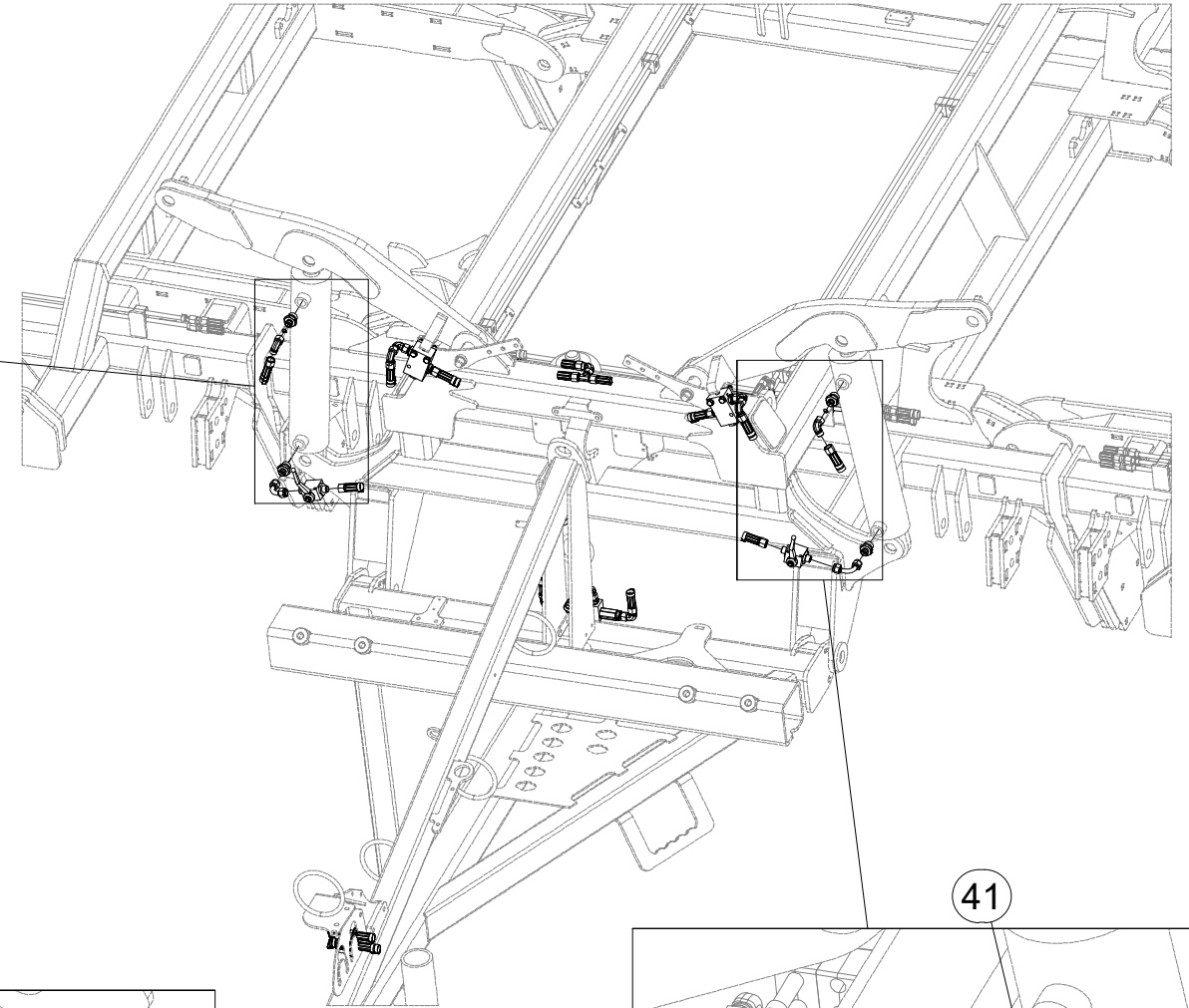
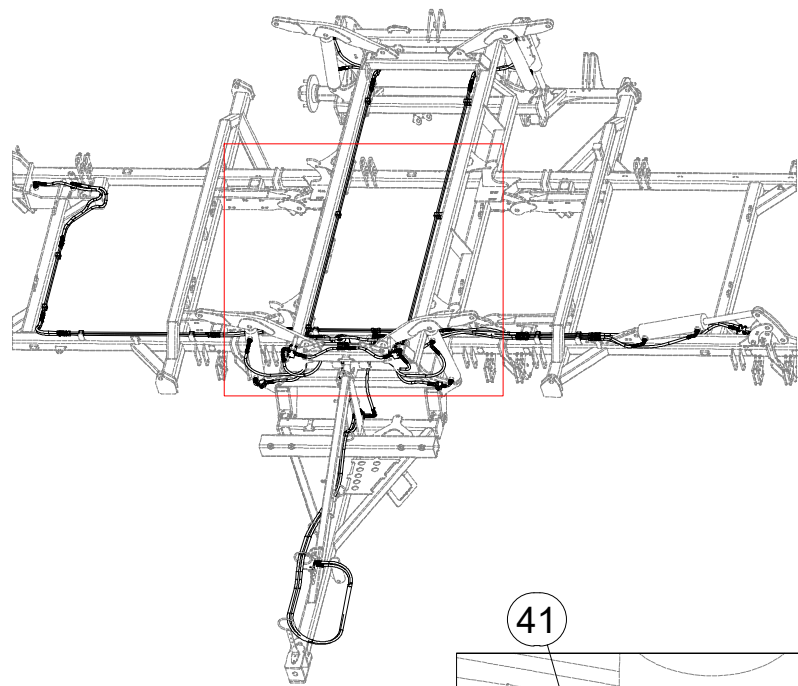

Pos.	Part Number	Pcs.
14	m06532	3
15	m04761	3
31	m04623	4
37	m10780	5
39	m10781	2
41	m09934	16
45	m06803	24
50	m04621	2
61	m11294	81



**VZ00010577**

**II**

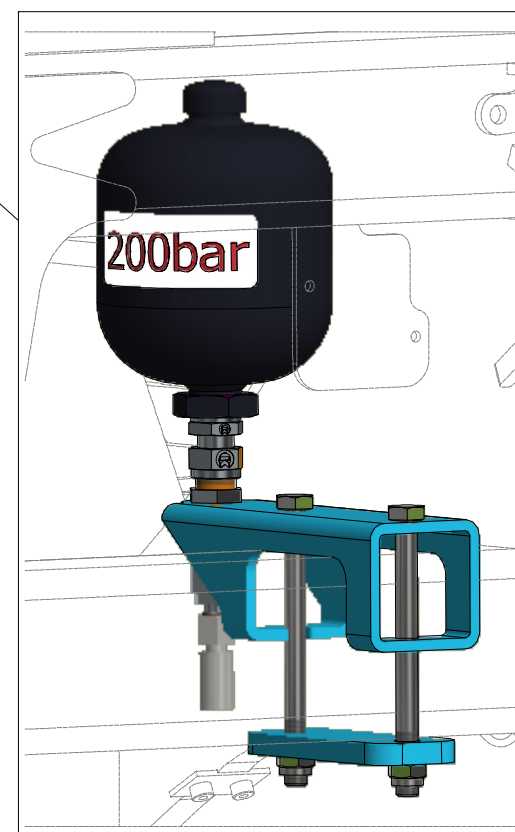
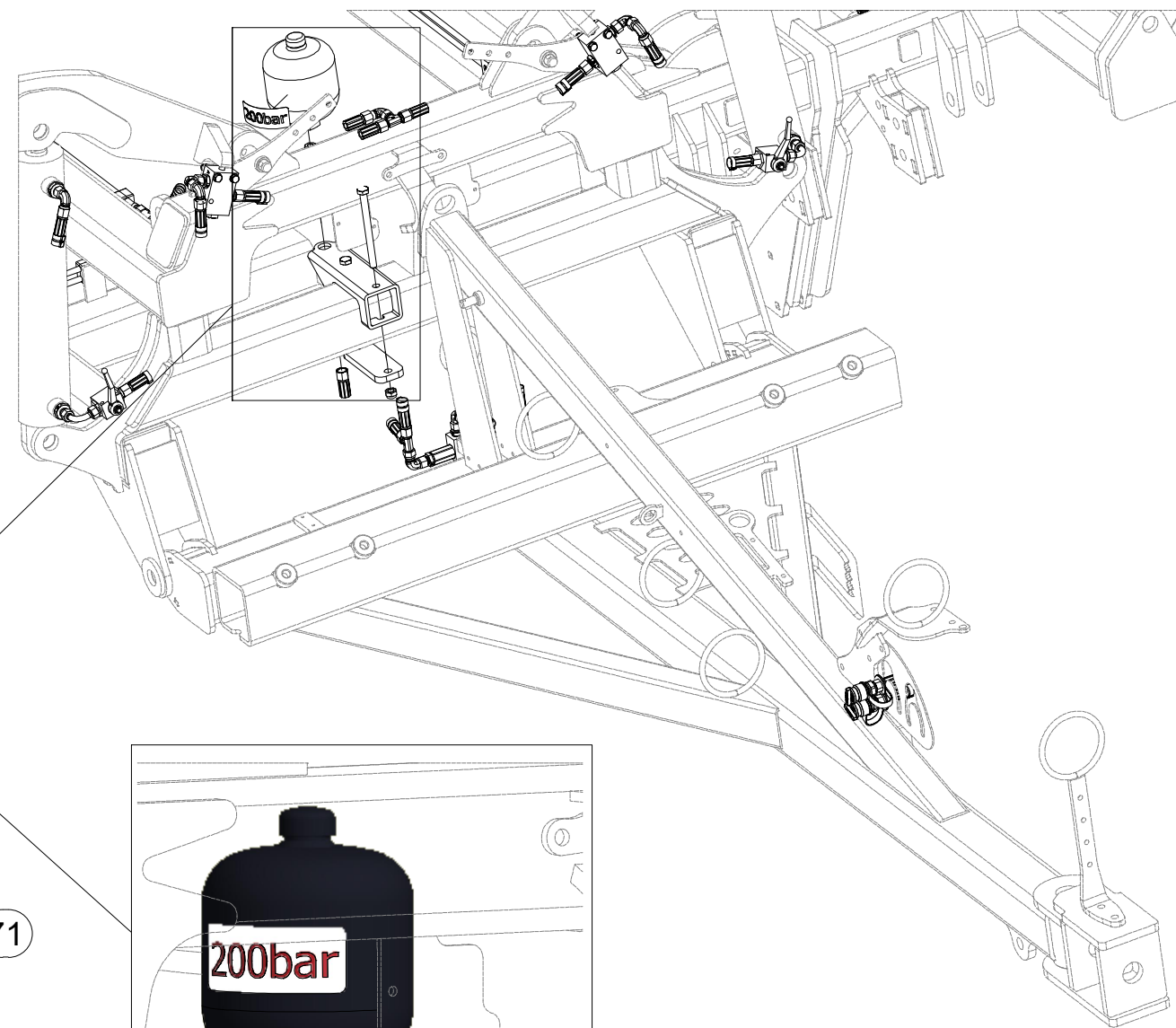
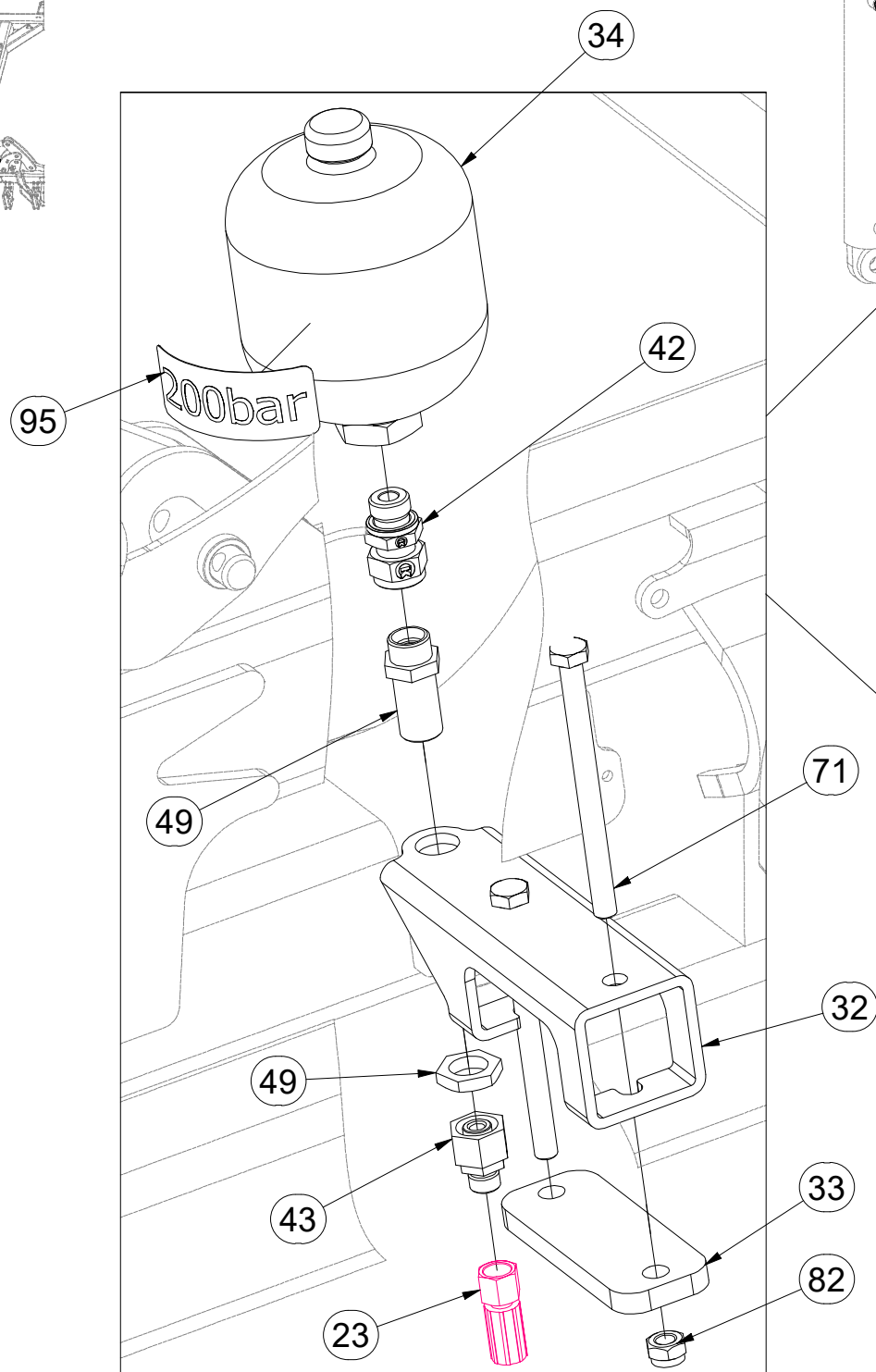
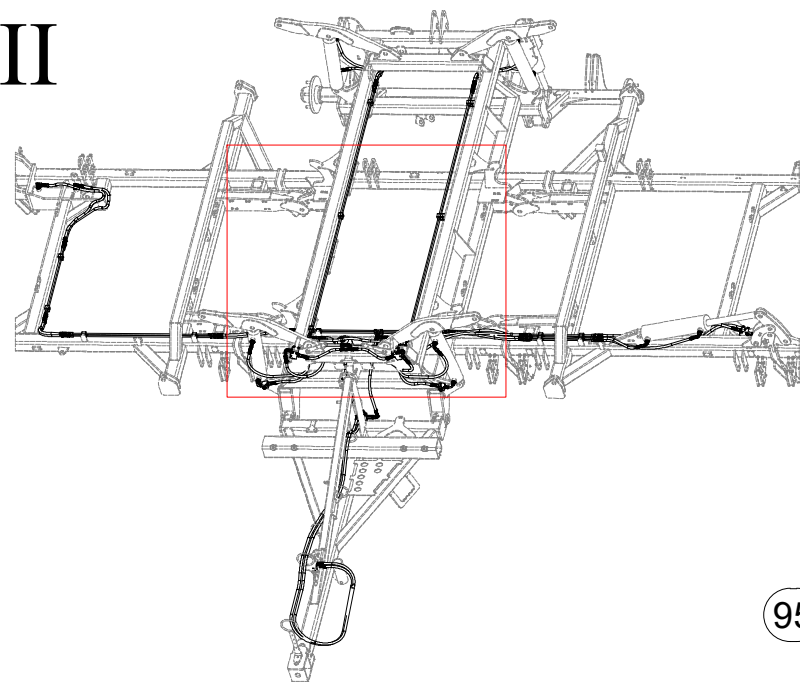

Pos.	Part Number	Pcs.
23	m11000	1
32	VZ00010565	1
33	4021194	1
34	m20926	1
42	m07993	1
43	m08533	1
49	m09625	1
71	m17481	2
82	m04301	2
95	m20976	1

VZ00010577

II

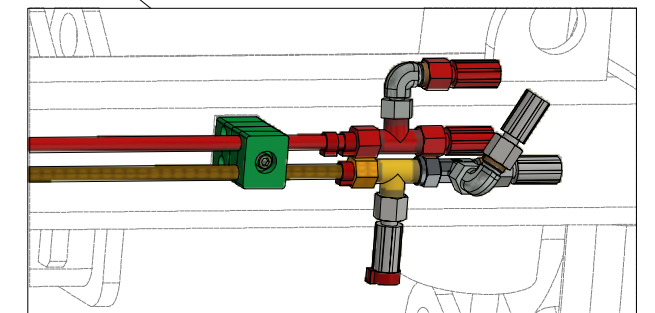
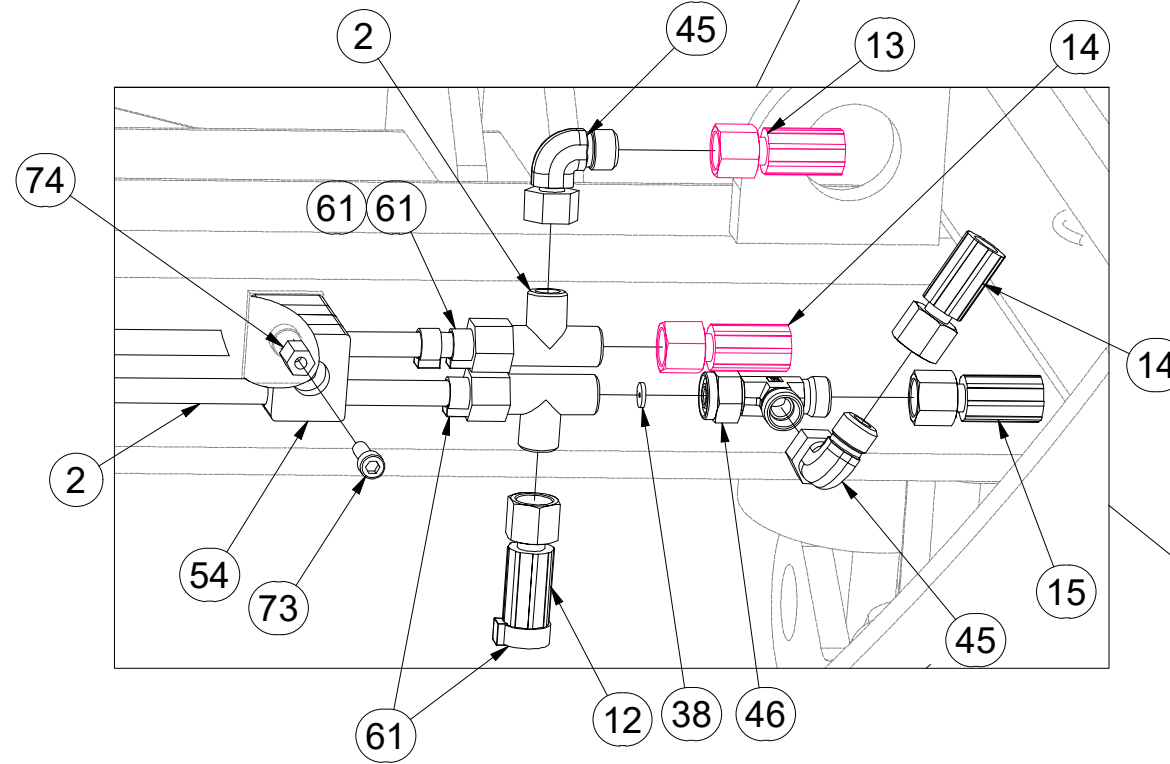
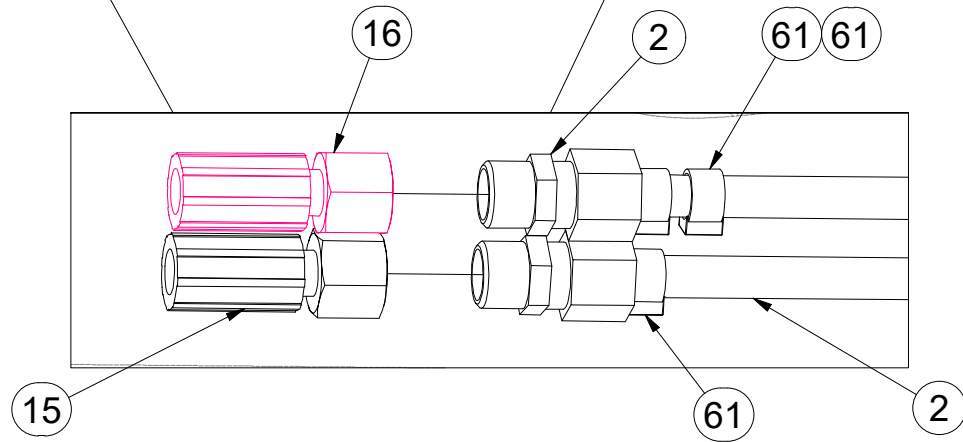
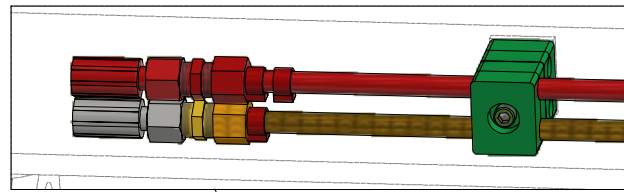
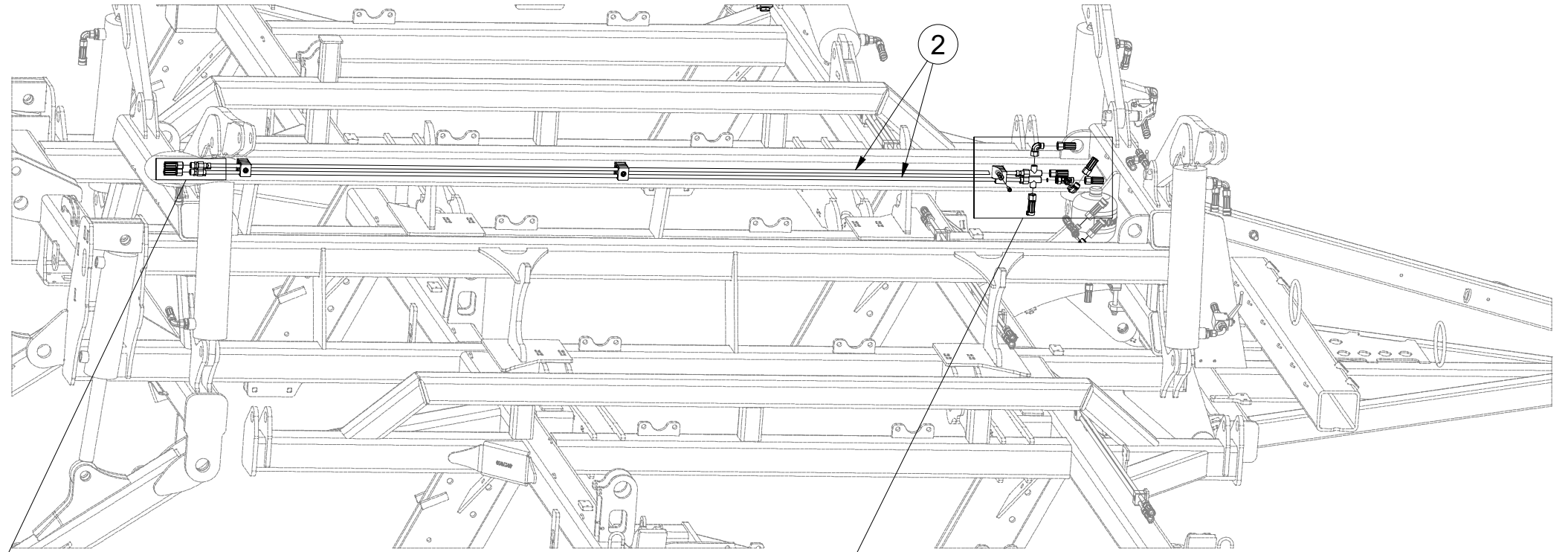
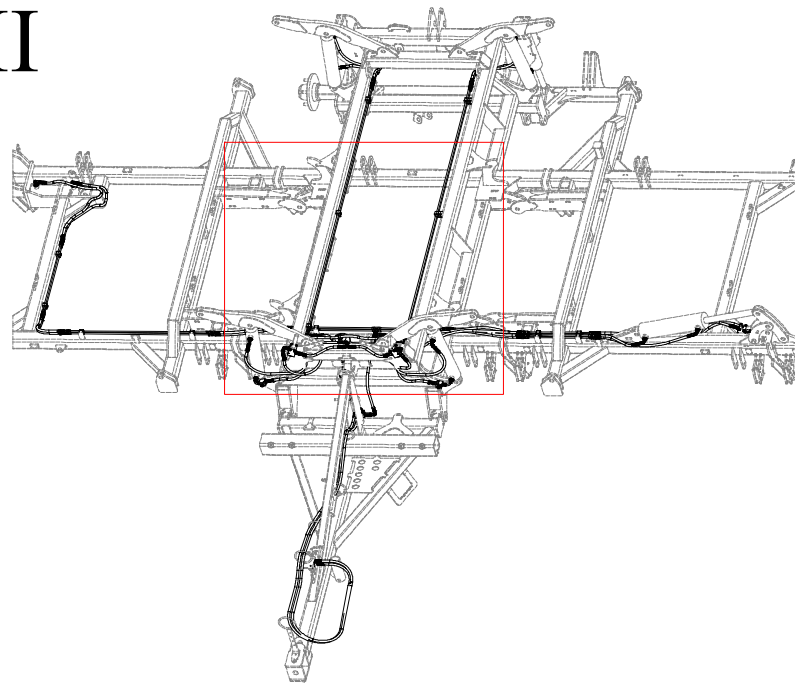

Pos.	Part Number	Pcs.	Pos.	Part Number	Pcs.
2	m10055	4	45	m06803	24
12	m03951	1	46	m07568	4
13	m03952	3	54	m05488	19
14	m06532	3	61	m11294	81
15	m04761	3	73	m04346	14
16	m04033	2	74	m04021	5
38	m10777	1			

Ⓒ HYDRAULIKA STROJE  
Ⓓ HYDRAULIK DER MASCHINE  
Ⓕ HYDRAULIQUE DE LA MACHINE

Ⓒ MACHINE HYDRAULICS  
Ⓔ ГИДРАВЛИКА МАШИНЫ  
Ⓗ HYDRAULIKA MASZYN



VZ00010577

II

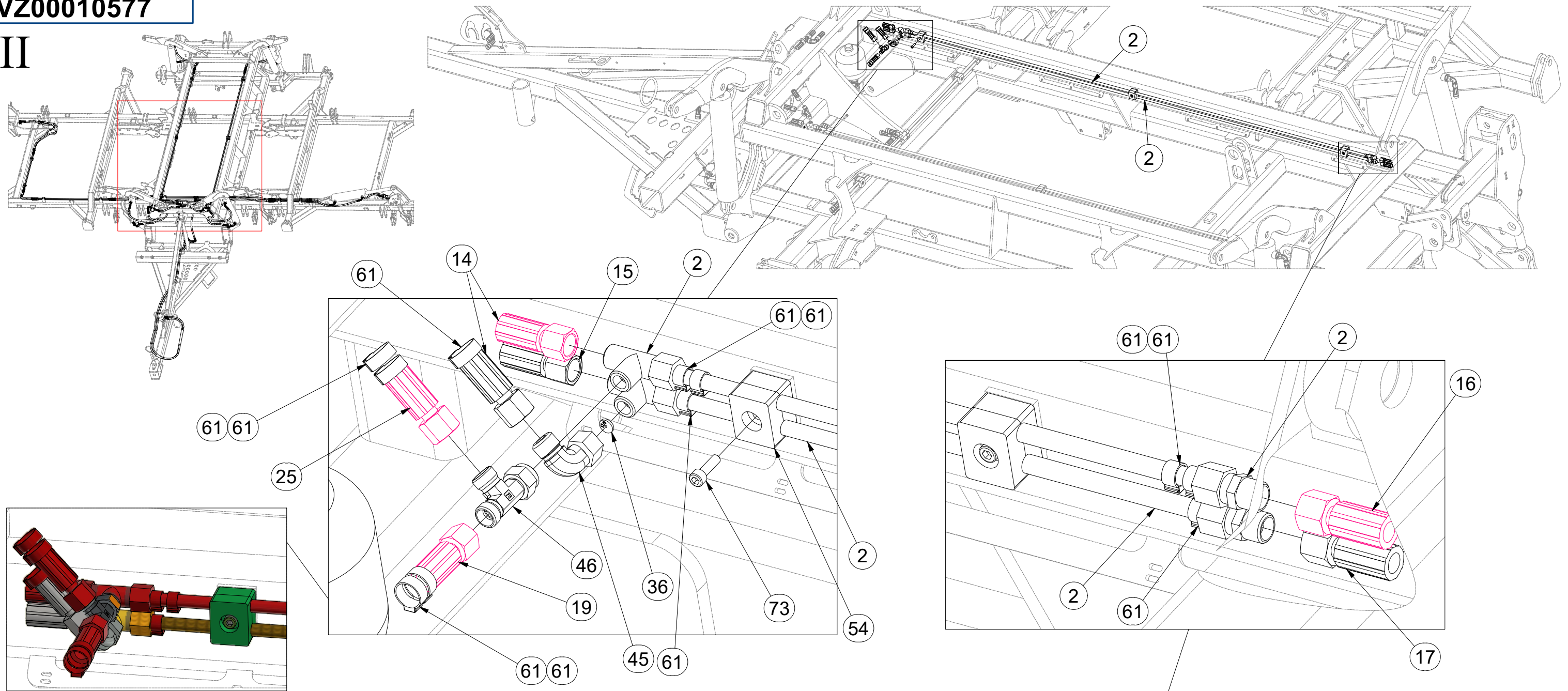

Pos.	Part Number	Pcs.	Pos.	Part Number	Pcs.	Pos.	Part Number	Pcs.
2	m10055	4	17	m09628	2	45	m06803	24
14	m06532	3	19	m07646	2	46	m07568	4
15	m04761	3	25	m04827	4	54	m05488	19
16	m04033	2	36	m10779	2	61	m11294	81
						73	m04346	14

Ⓒ HYDRAULIKA STROJE

Ⓓ HYDRAULIK DER MASCHINE

Ⓕ HYDRAULIQUE DE LA MACHINE

Ⓖ MACHINE HYDRAULICS

Ⓡ ГИДРАВЛИКА МАШИНЫ

Ⓟ HYDRAULIKA MASZYN



VZ00010577

II

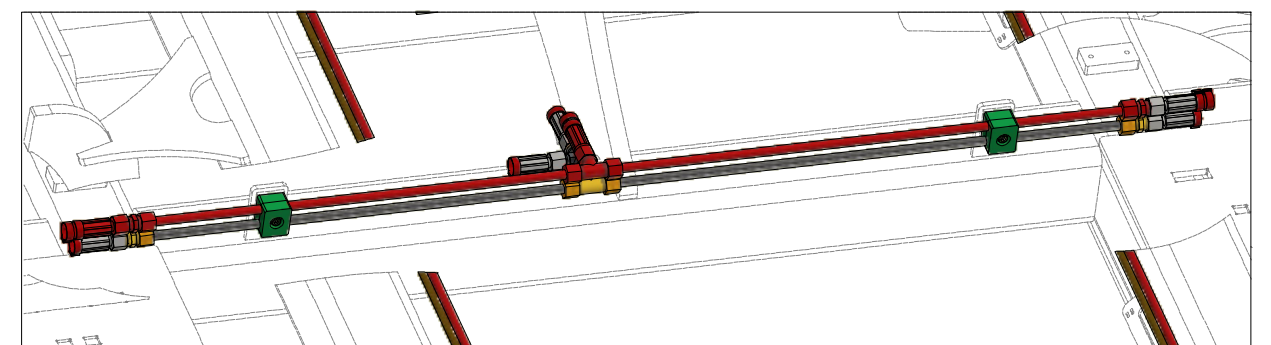
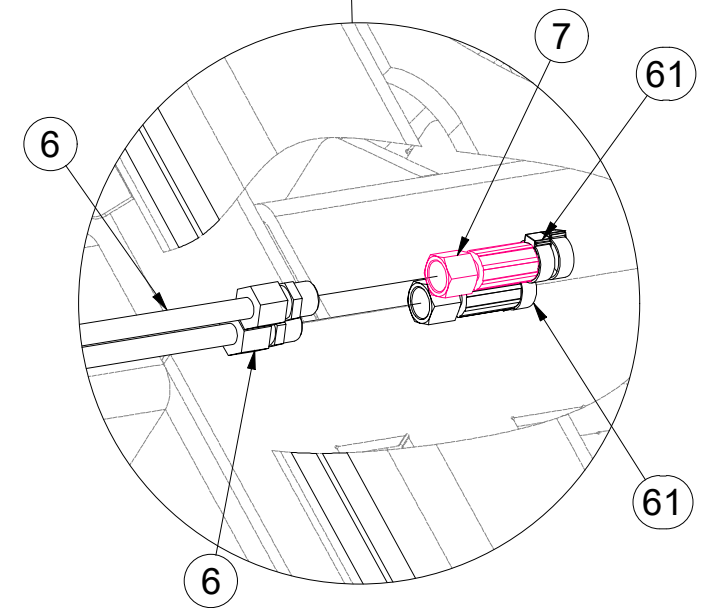
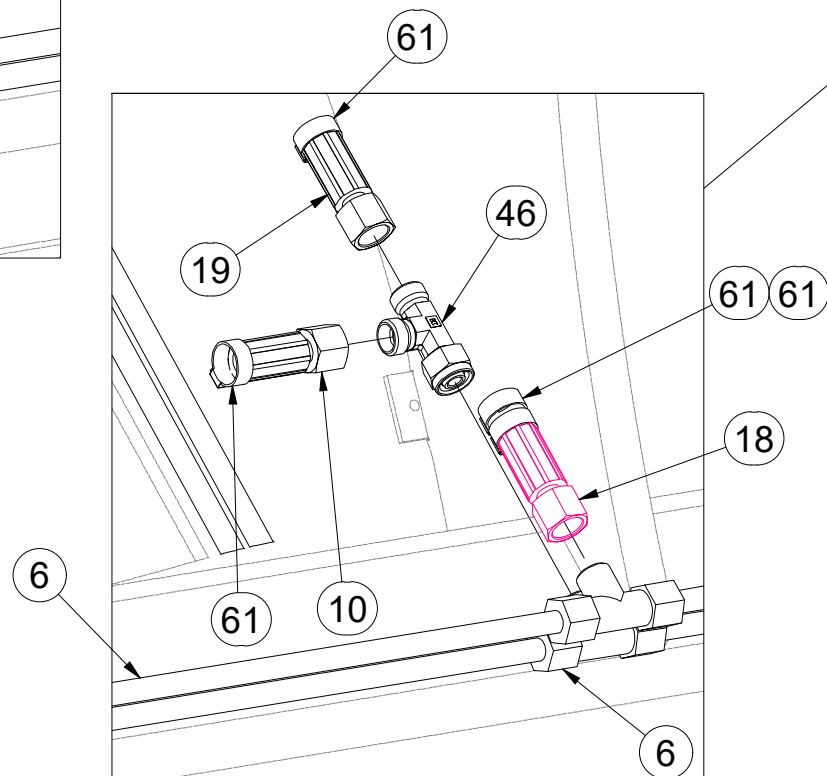
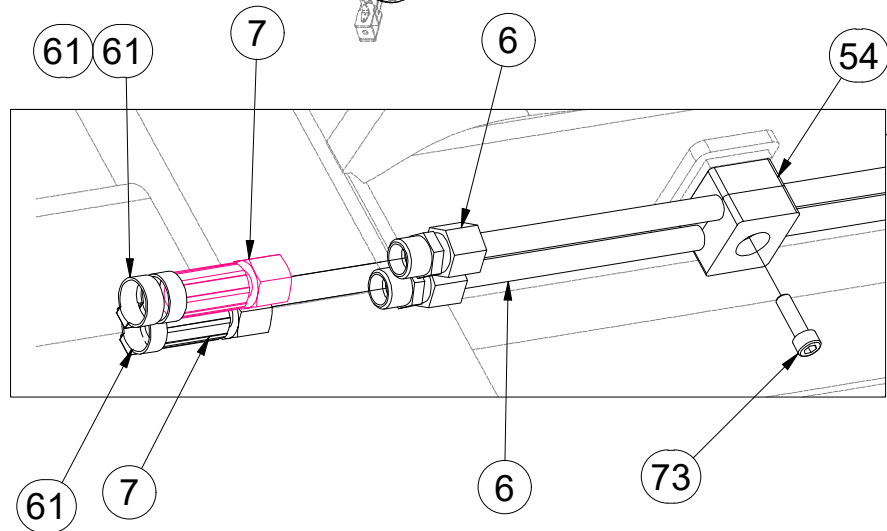
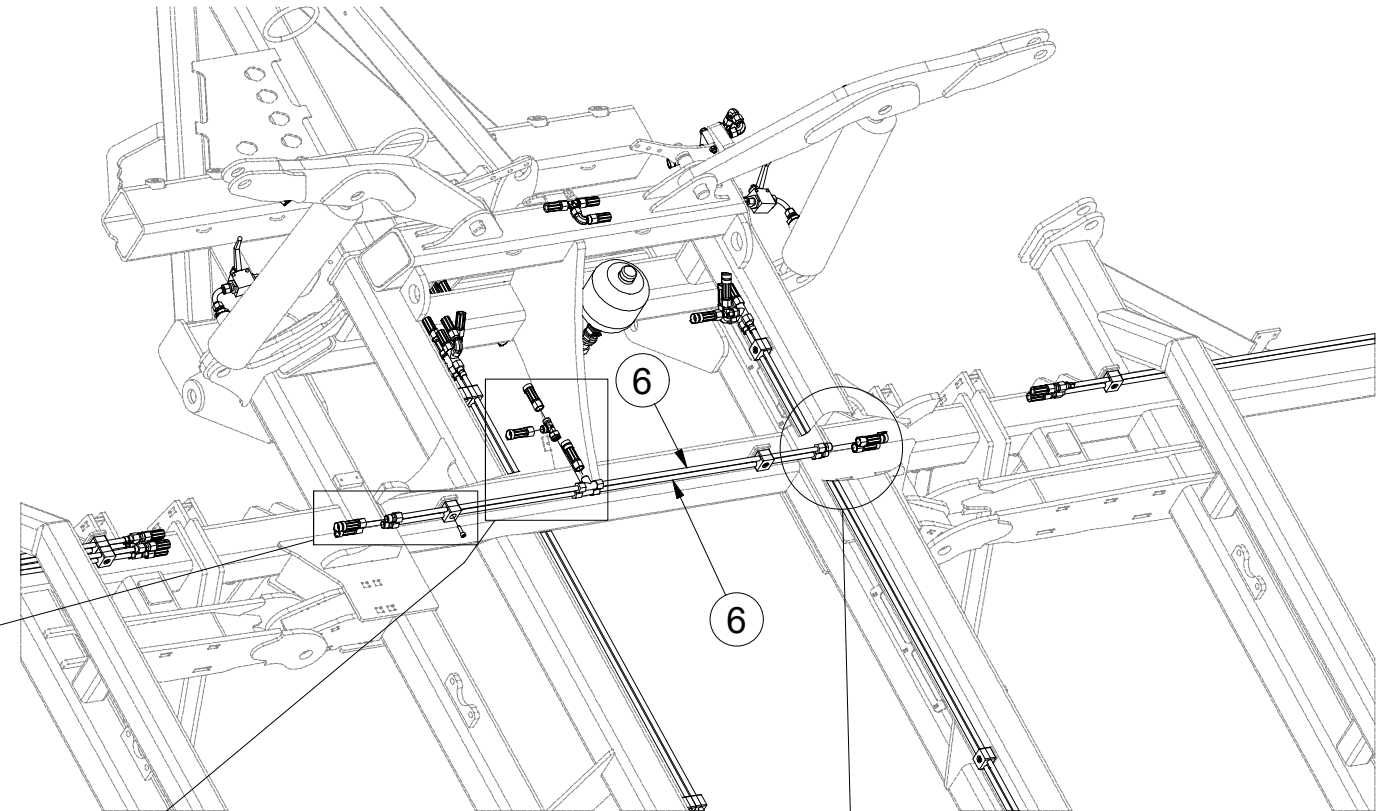
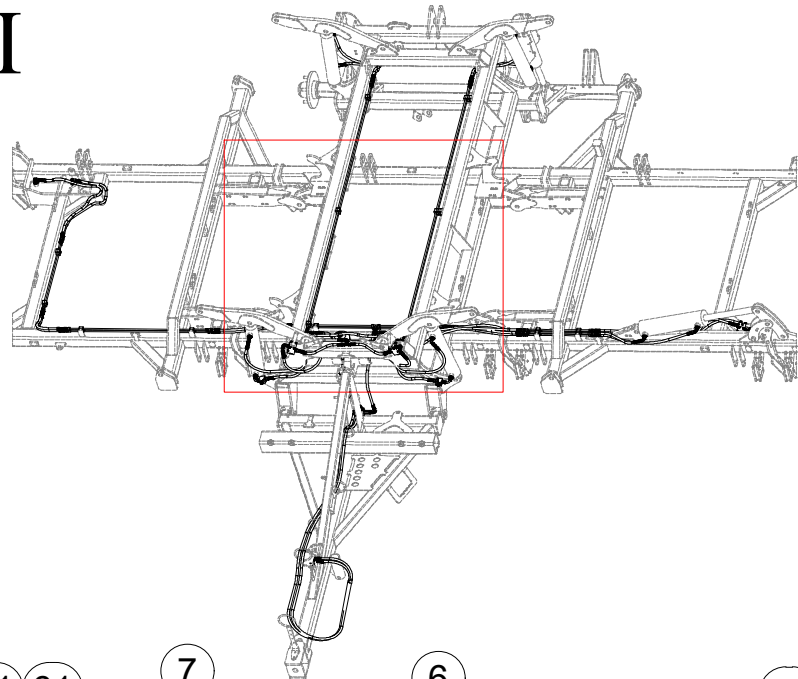

Pos.	Part Number	Pcs.
6	m10054	2
7	m03713	4
10	m05210	2
18	m04669	1
19	m07646	2
46	m07568	4
54	m05488	19
61	m11294	81
73	m04346	14

VZ00010577

III

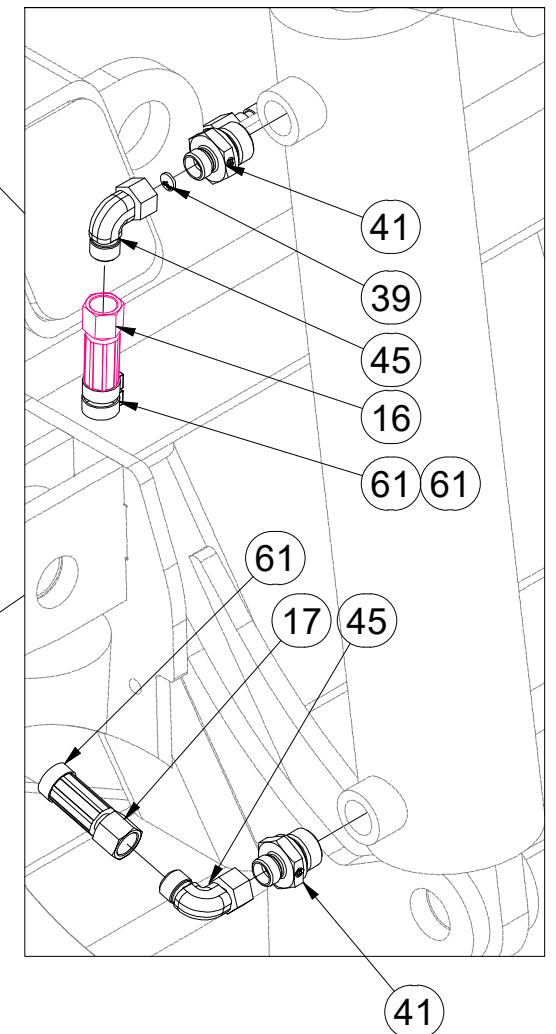
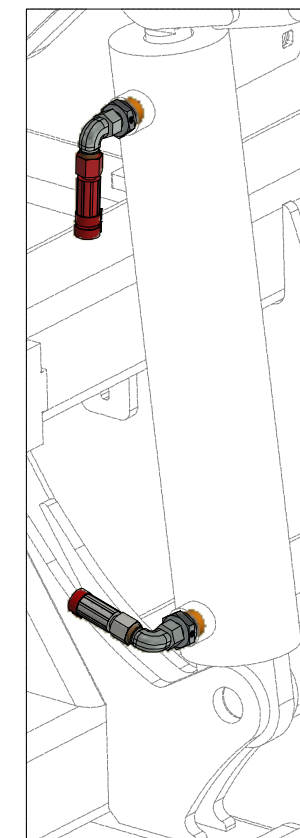
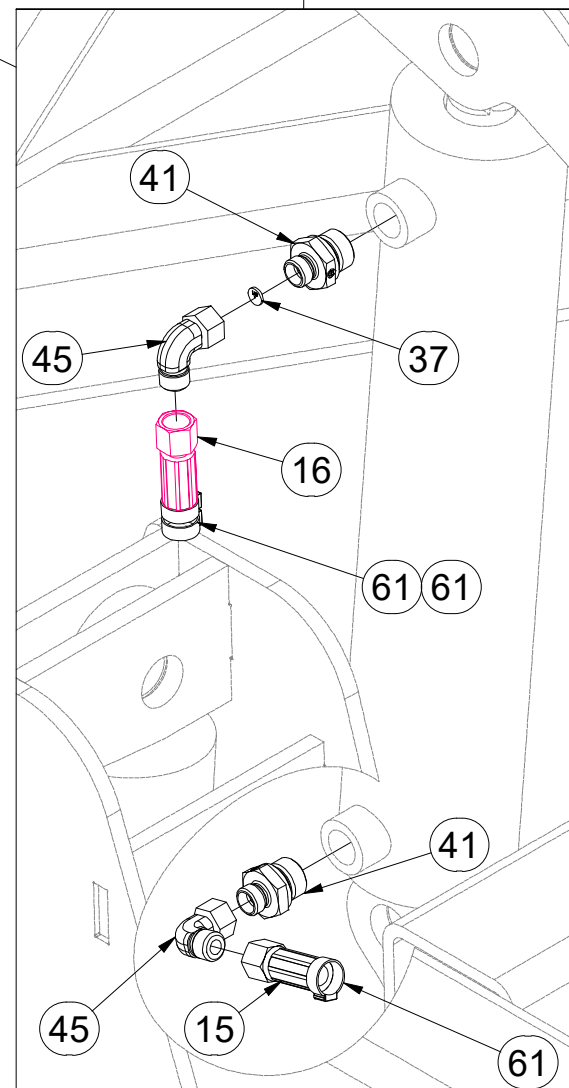
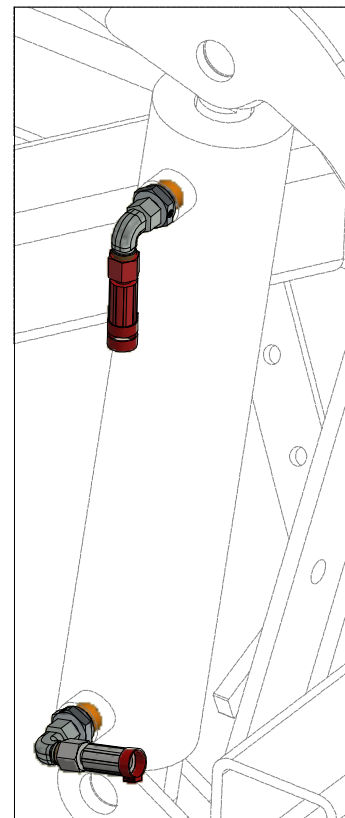
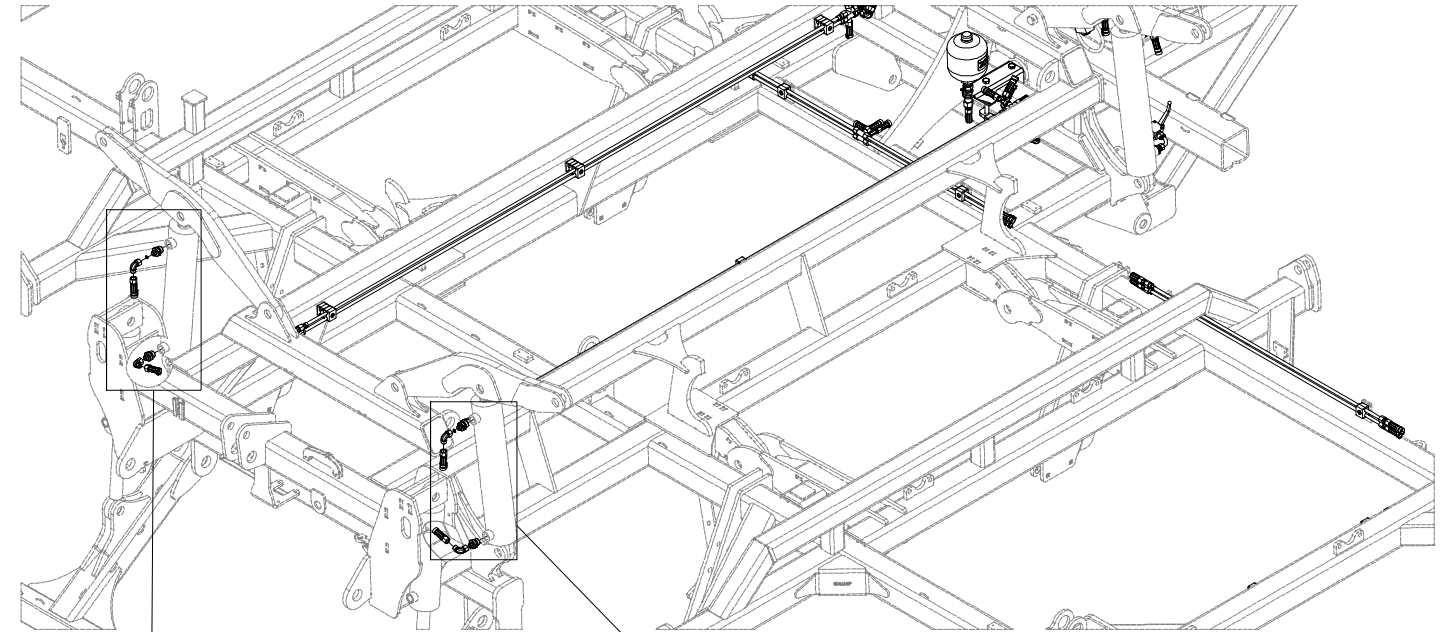
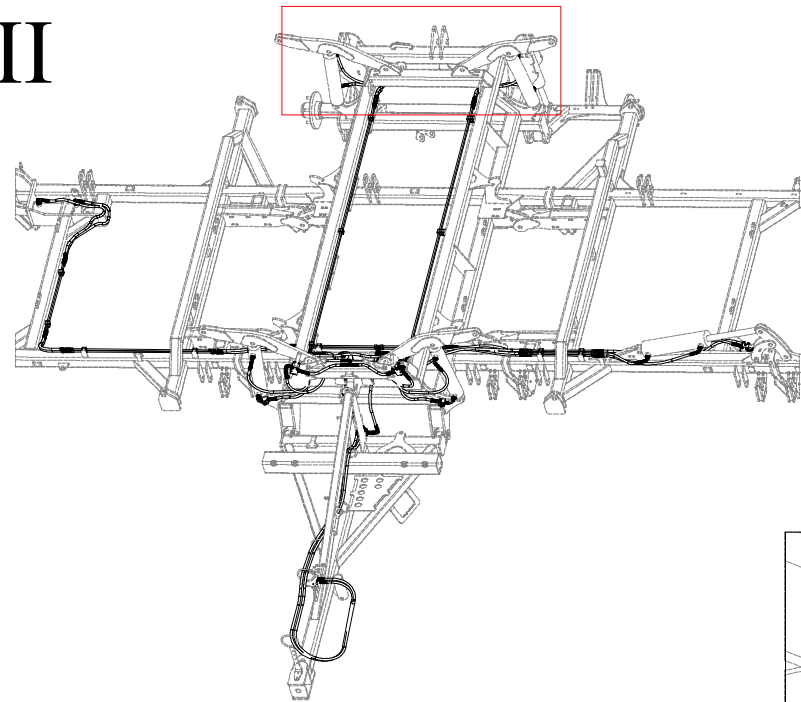

Pos.	Part Number	Pcs.
15	m04761	3
16	m04033	2
17	m09628	2
37	m10780	5
39	m10781	2
41	m09934	16
45	m06803	24
61	m11294	81

Ⓒ HYDRAULIKA STROJE

Ⓓ HYDRAULIK DER MASCHINE

Ⓕ HYDRAULIQUE DE LA MACHINE

Ⓖ MACHINE HYDRAULICS

Ⓡ ГИДРАВЛИКА МАШИНЫ

Ⓟ HYDRAULIKA MASZYNY



VZ00010577

IV

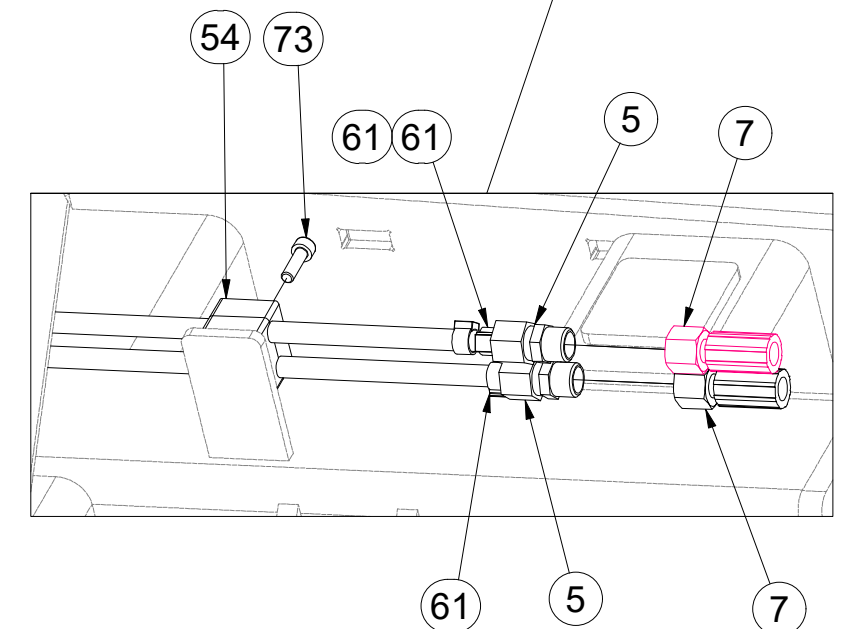
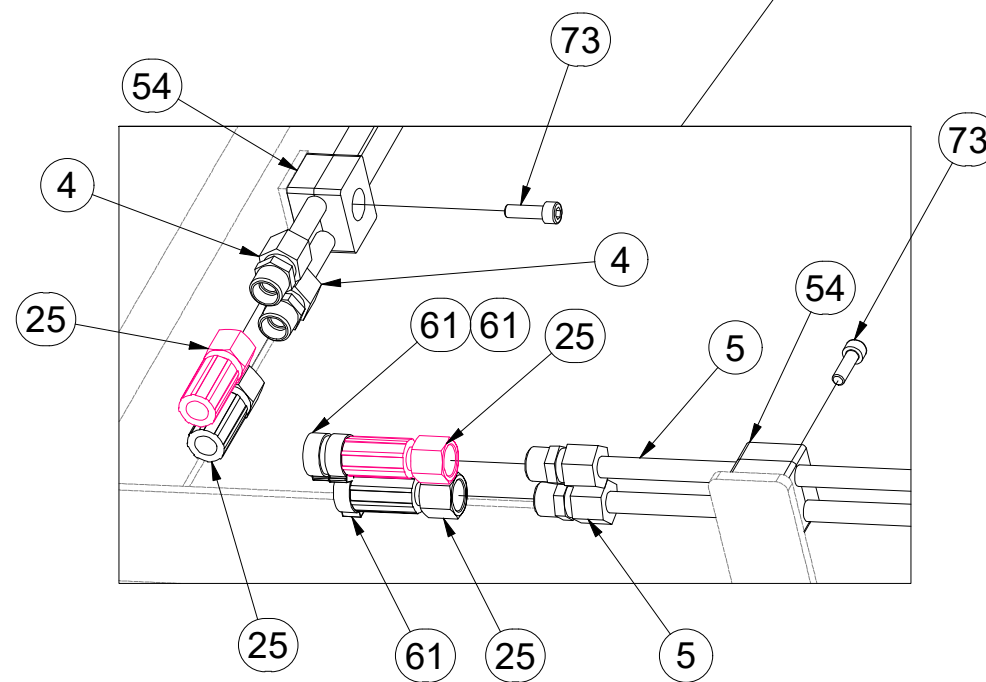
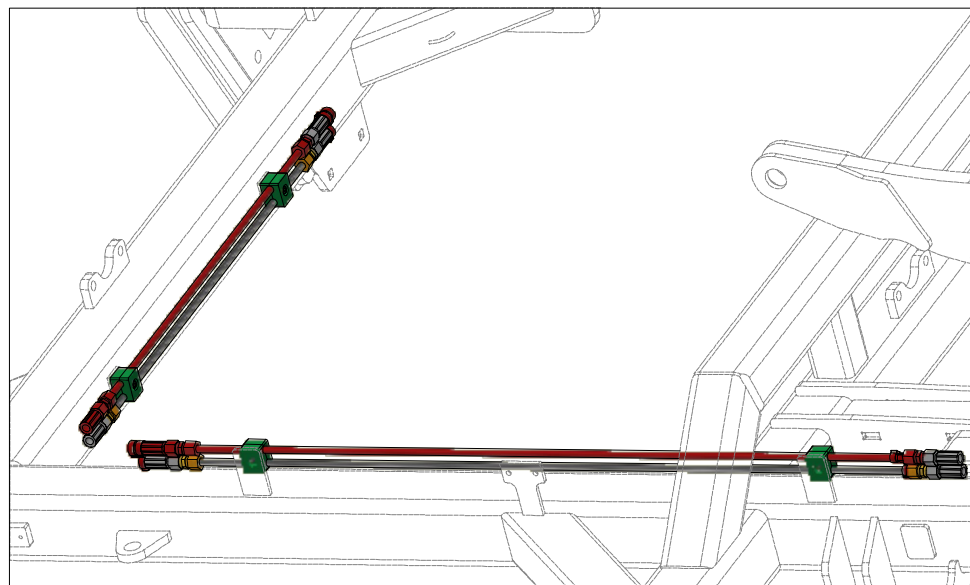
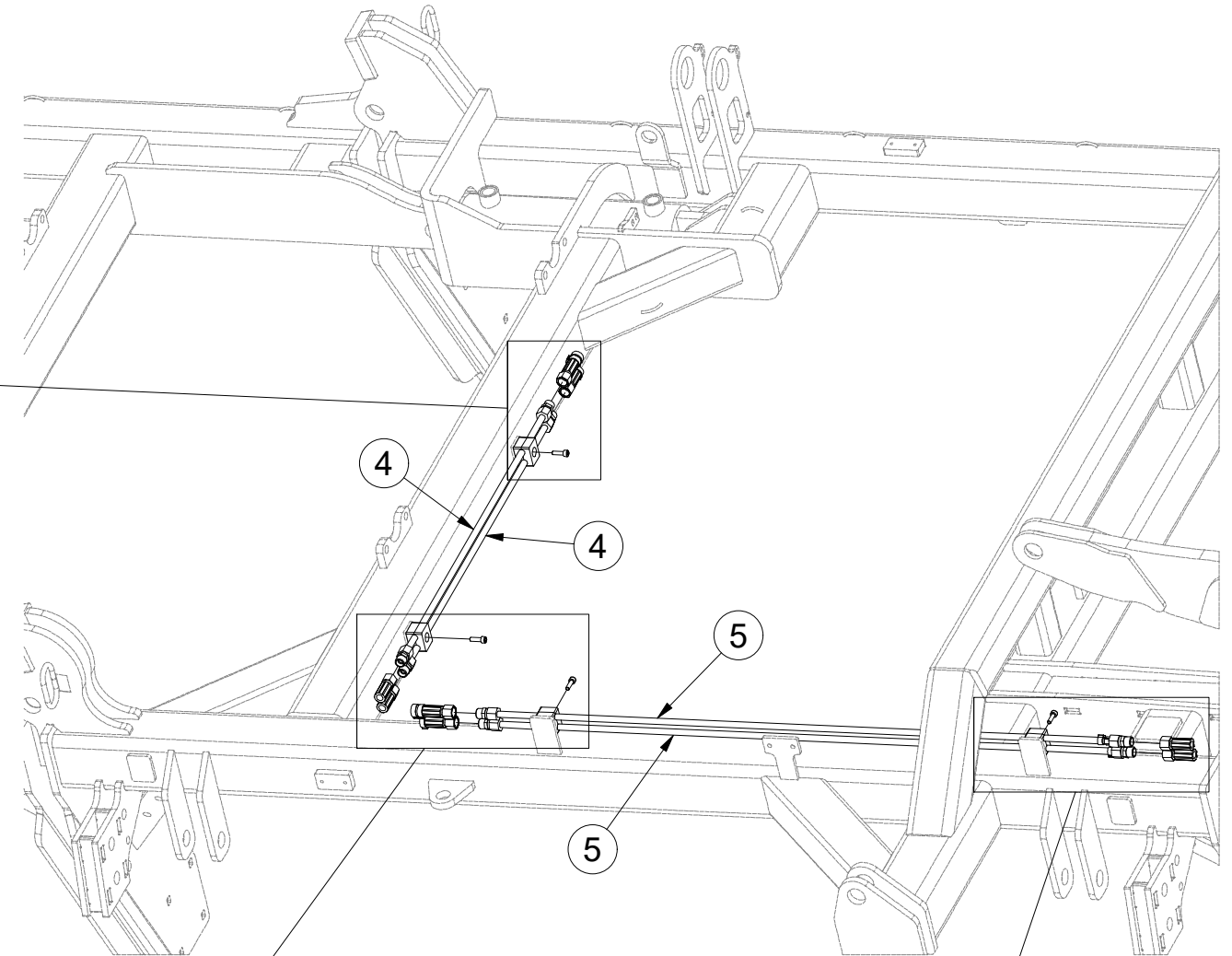
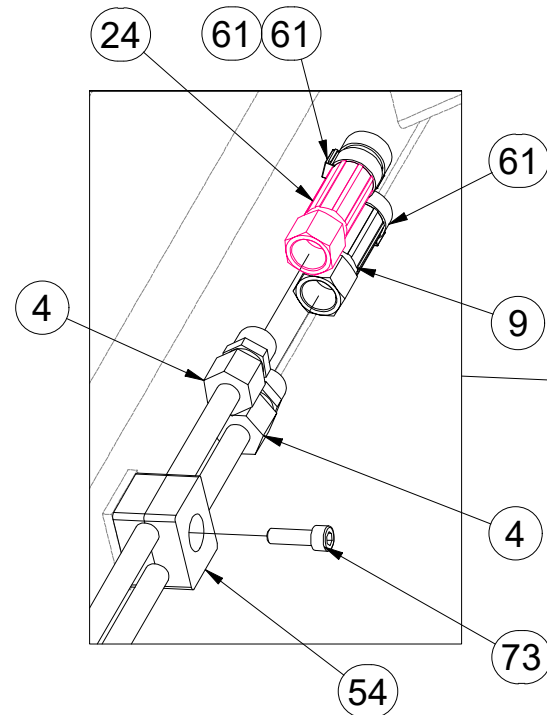
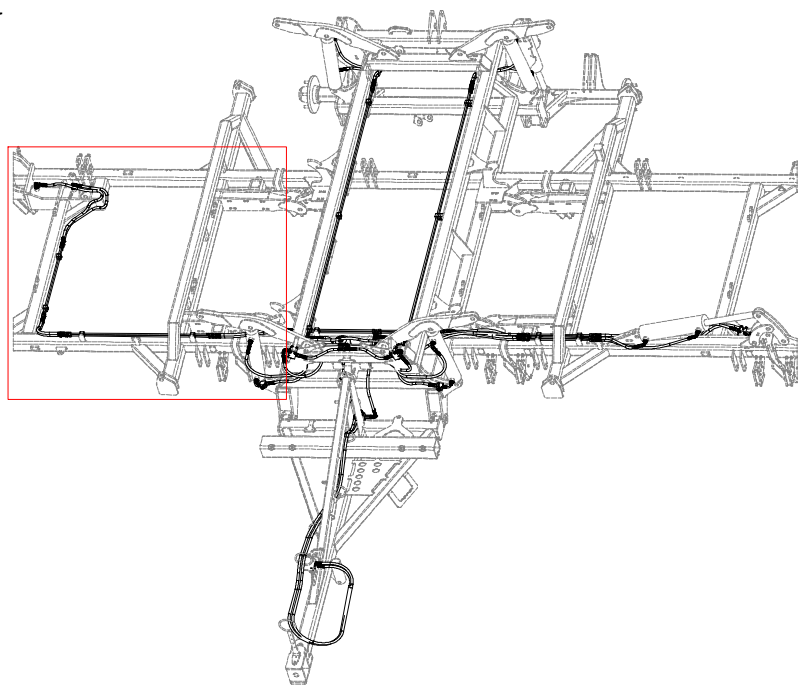

Pos.	Part Number	Pcs.
4	m10052	2
5	m10053	2
7	m03713	4
9	m07364	2
24	m17041	1
25	m04827	4
54	m05488	19
61	m11294	81
73	m04346	14

**VZ00010577**

**IV**

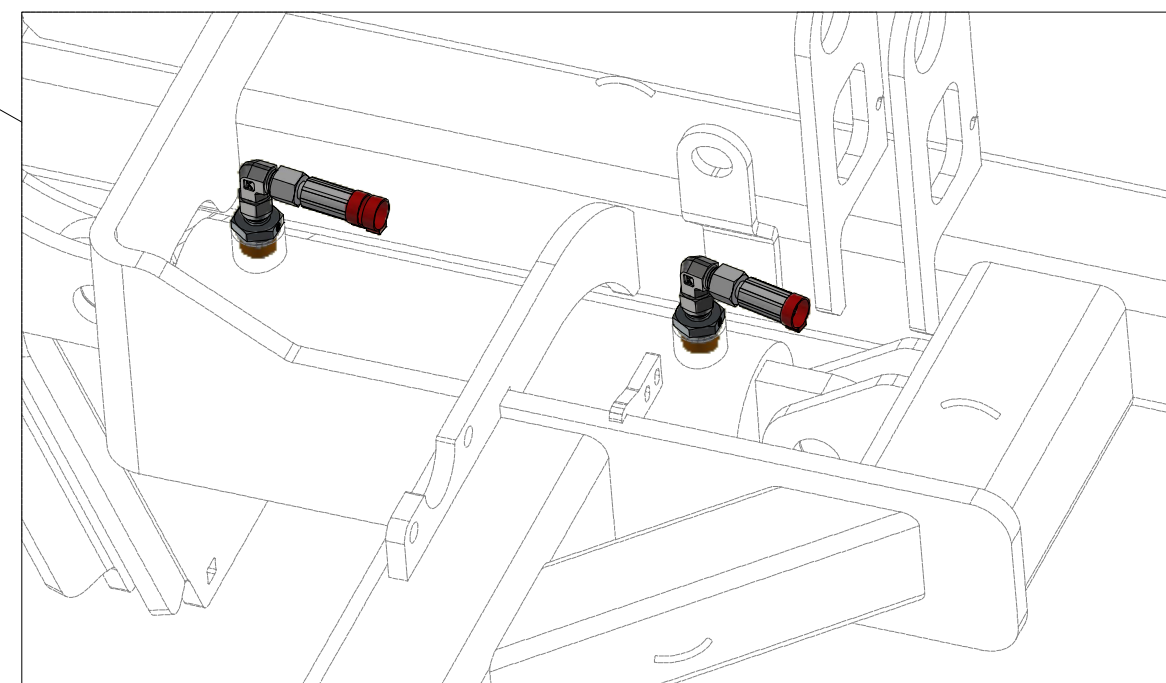
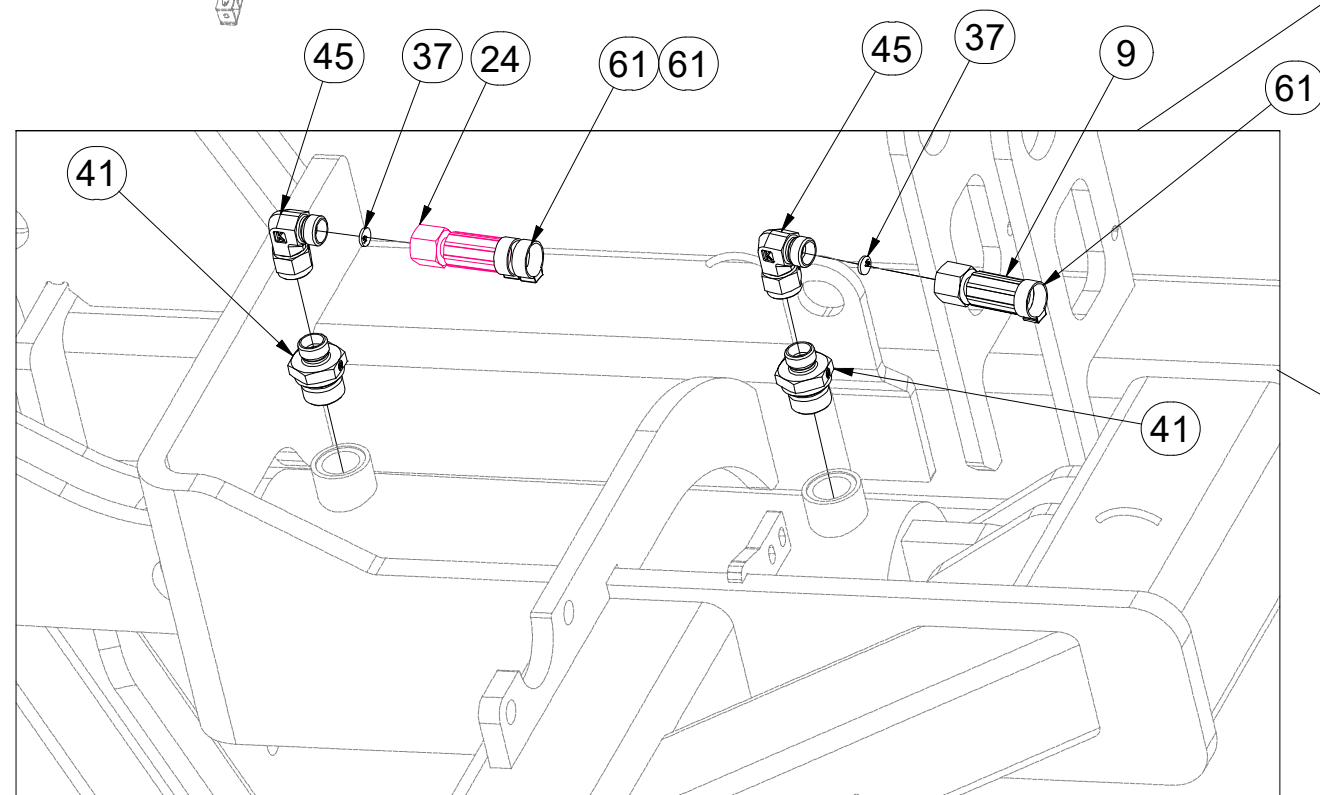
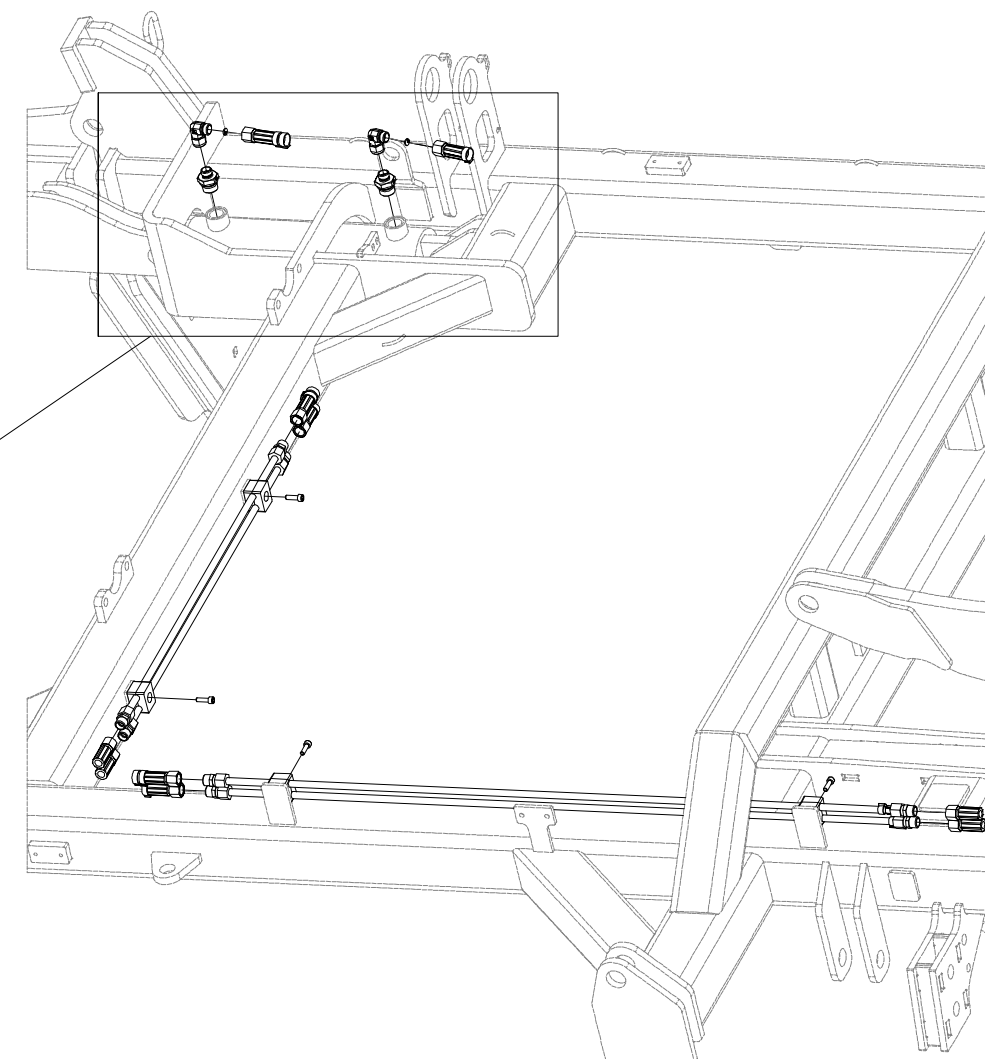
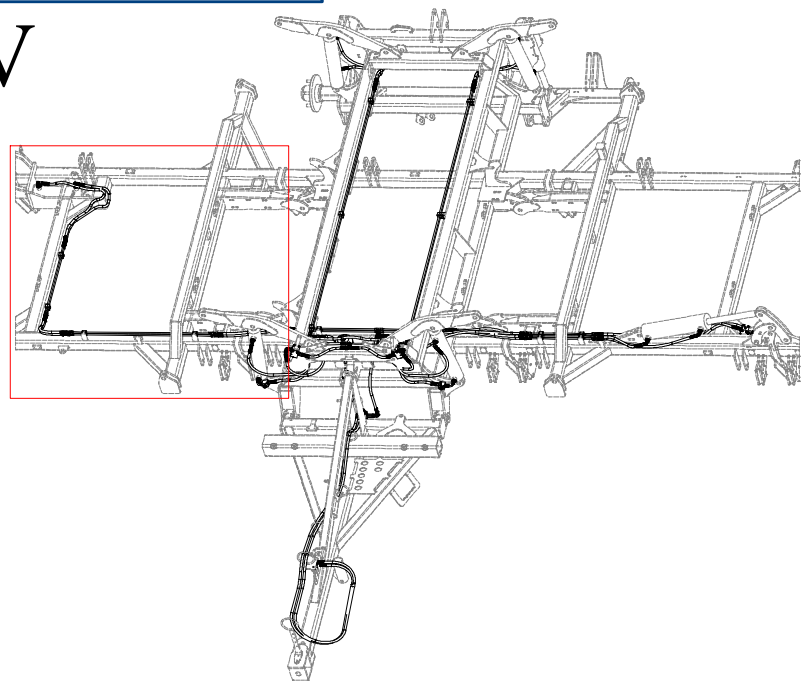

Pos.	Part Number	Pcs.
9	m07364	2
24	m17041	1
37	m10780	5
41	m09934	16
45	m06803	24
61	m11294	81

ⒸZ HYDRAULIKA STROJE

Ⓓ HYDRAULIK DER MASCHINE

Ⓕ HYDRAULIQUE DE LA MACHINE

ⒼB MACHINE HYDRAULICS

Ⓔ RU ГИДРАВЛИКА МАШИНЫ

Ⓗ PL HYDRAULIKA MASZYN



VZ00010577

V

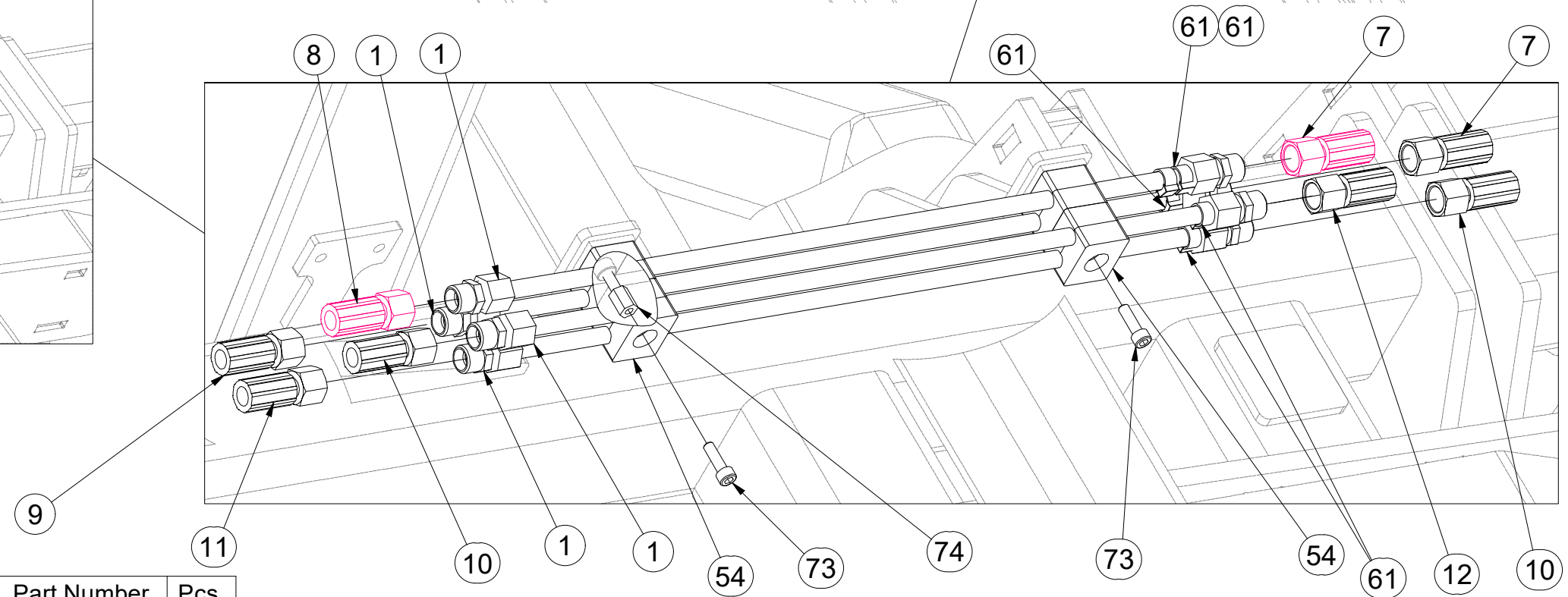
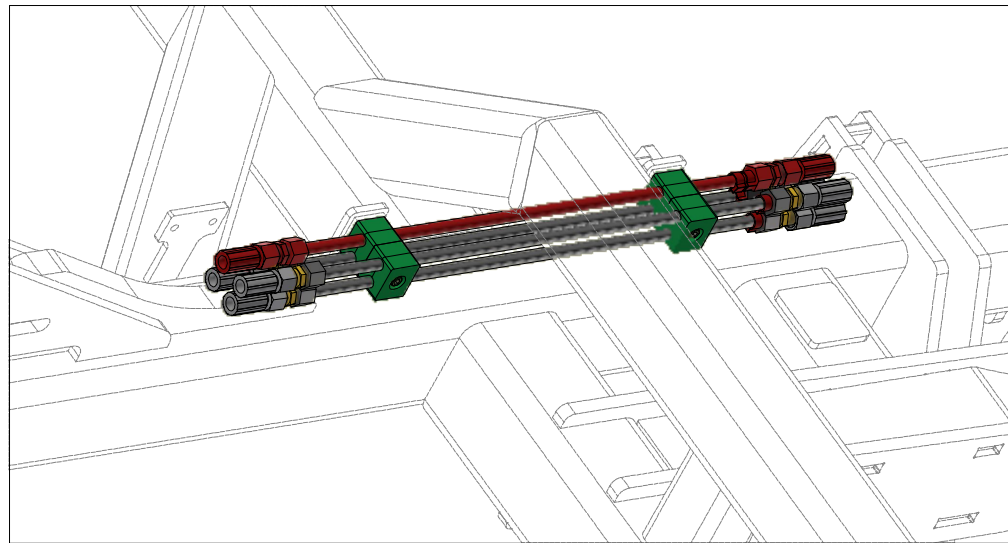
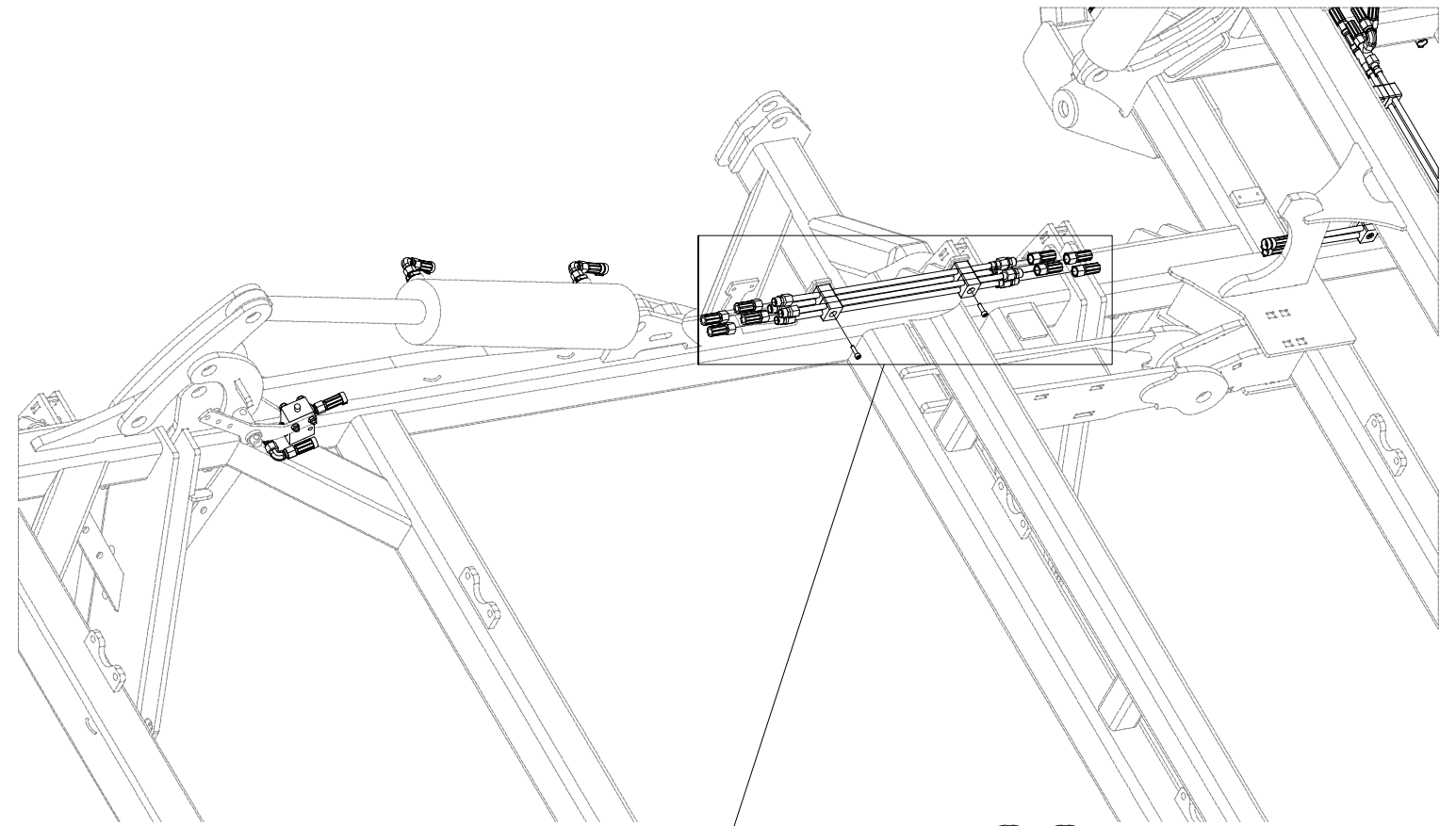
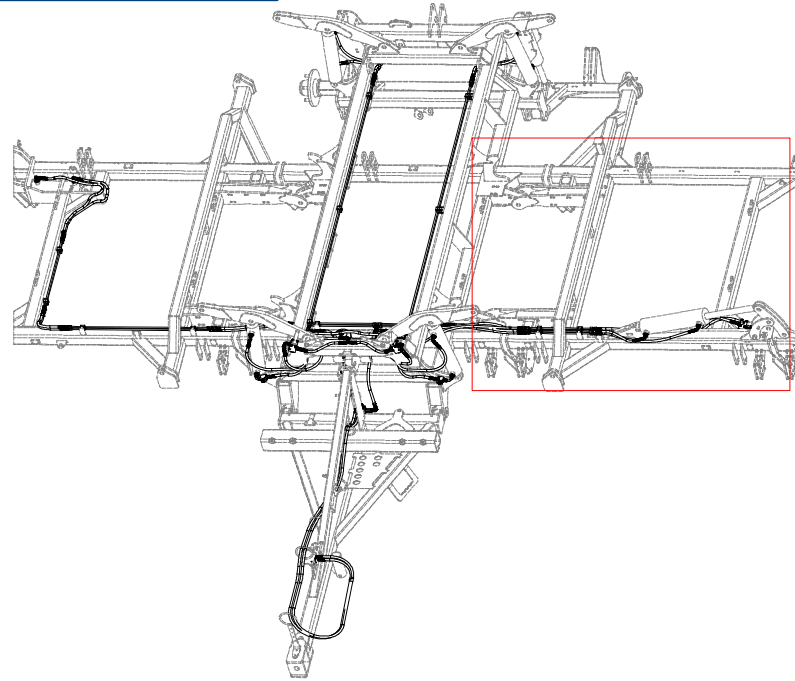

Pos.	Part Number	Pcs.	Pos.	Part Number	Pcs.	Pos.	Part Number	Pcs.
1	m10051	4	10	m05210	2	61	m11294	81
7	m03713	4	11	m07504	1	73	m04346	14
8	m11126	1	12	m03951	1	74	m04021	5
9	m07364	2	54	m05488	19			



**VZ00010577**

**V**

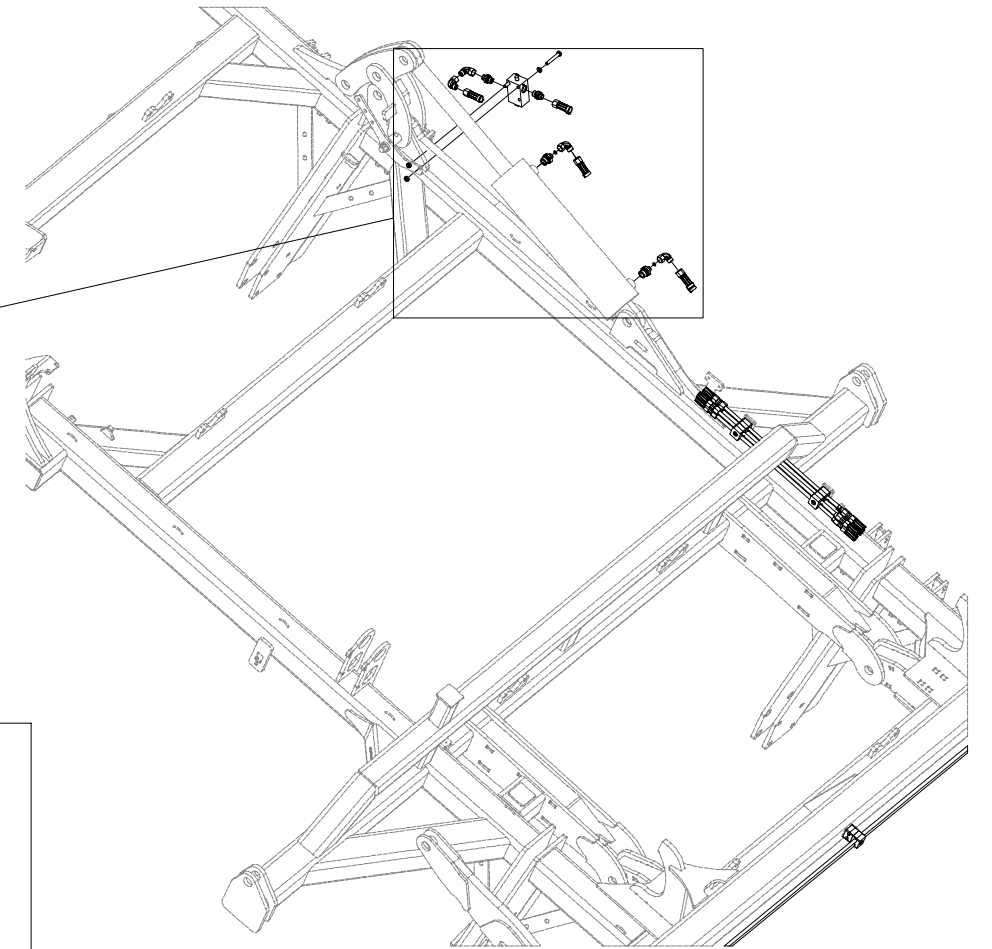
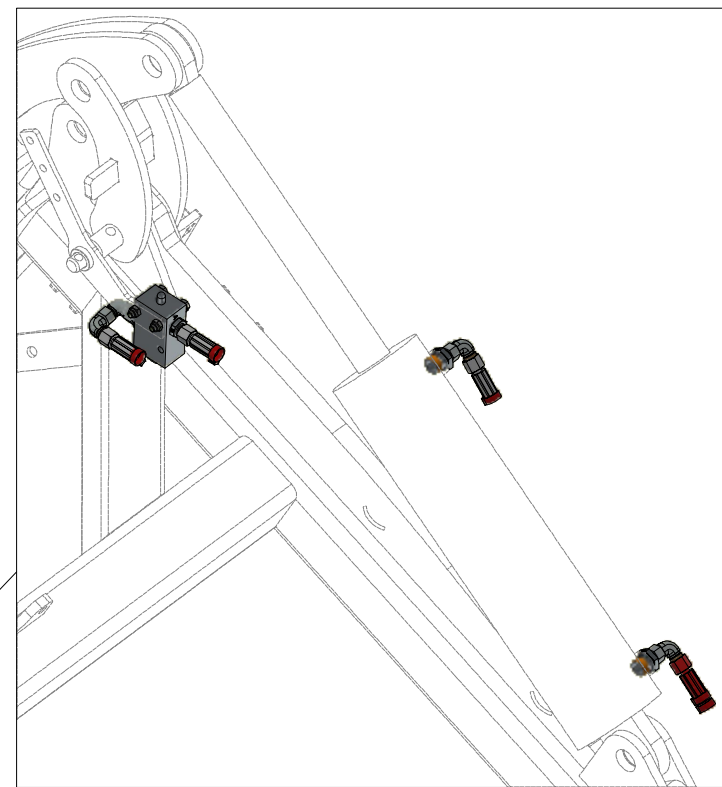
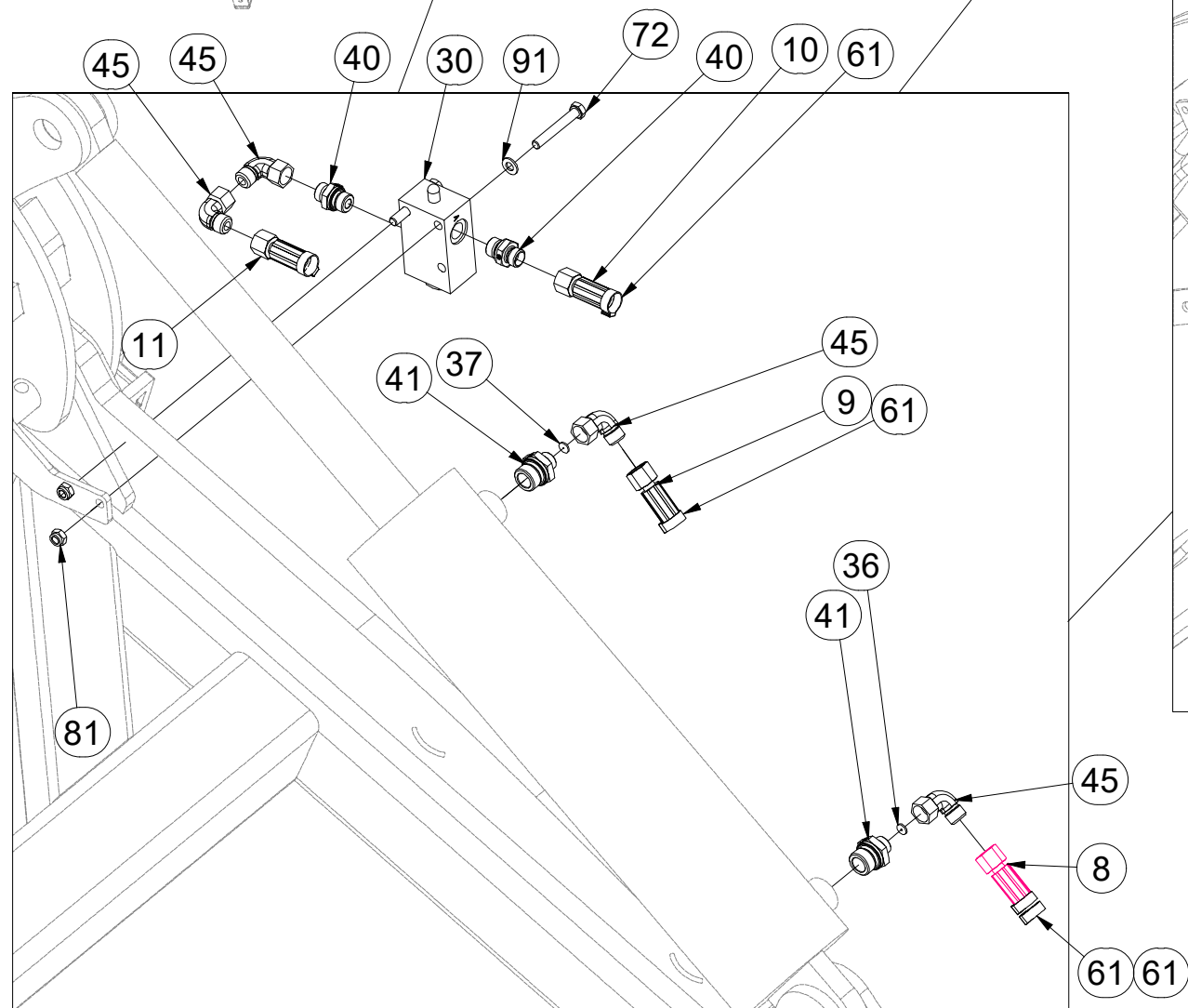
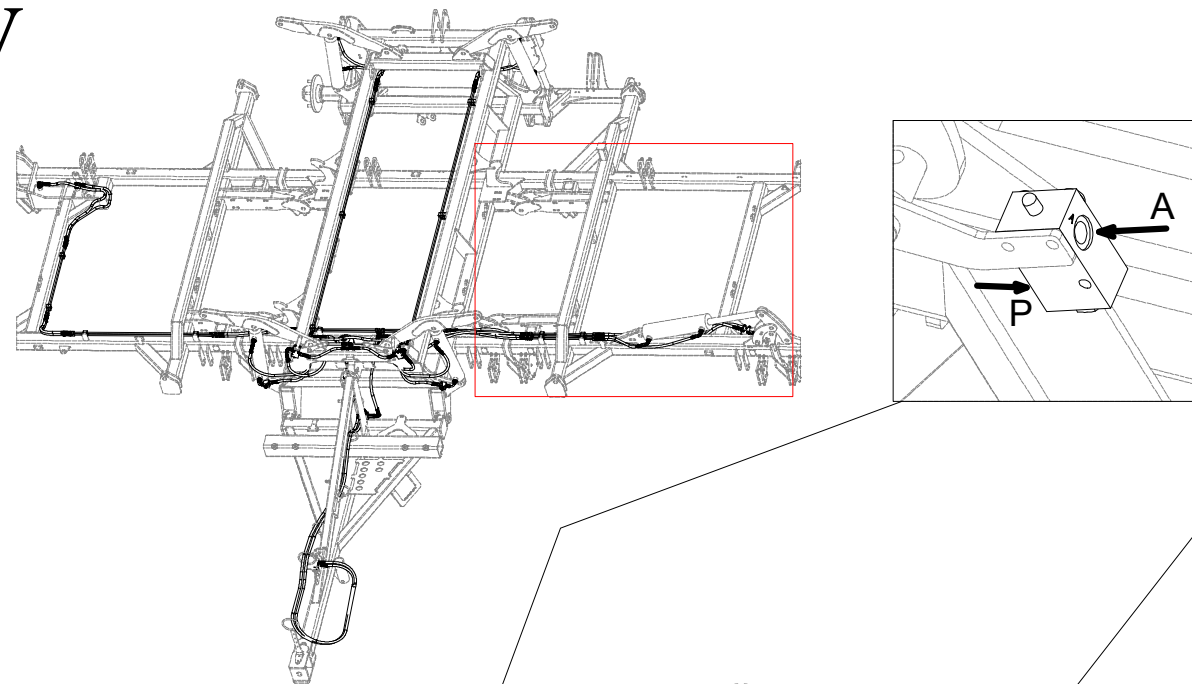

Pos.	Part Number	Pcs.	Pos.	Part Number	Pcs.
8	m11126	1	40	m06528	10
9	m07364	2	41	m09934	16
10	m05210	2	45	m06803	24
11	m07504	1	61	m11294	81
30	m10261	3	72	m10593	6
36	m10779	2	81	m04503	6
37	m10780	5	91	m01203	6

Ⓒ CZ OJ T3

Ⓓ DEICHSEL T3

Ⓕ TIMON T3

**3012414**

Ⓖ GB TOW BAR T3

Ⓡ RU ДЫШЛО T3

Ⓟ PL DYSZEL T3

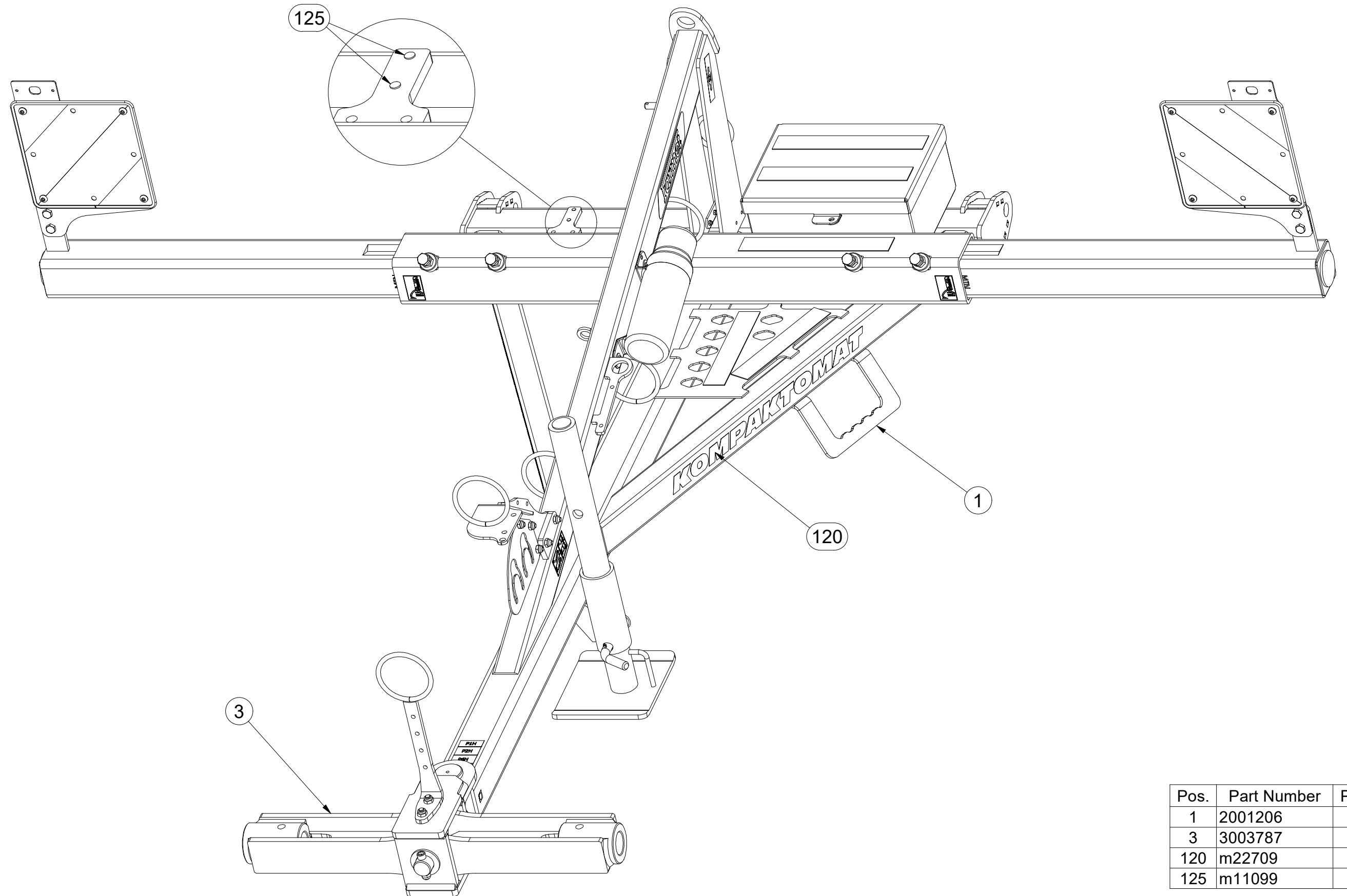

Pos.	Part Number	Pcs.
1	2001206	1
3	3003787	1
120	m22709	1
125	m11099	2

Ⓒ CZ OJ T3

Ⓓ DEICHSEL T3

Ⓕ TIMON T3

Ⓖ GB TOW BAR T3

Ⓡ RU ДЫШЛО T3

Ⓟ PL DYSZEL T3



**3012414**

Pos.	Part Number	Pcs.	Pos.	Part Number	Pcs.
1	2001206	1	72	m04613	2
2	3009637	1	74	m03926	2
3	3003787	1	75	m03681	3
4	4003744	2	76	m14008	2
5	4008049	1	86	m03775	5
6	4014570	1	88	m04301	8
10	8000647-40207	1	90	m02533	1
11	4012205	1	101	m03866	1
13	3012460	1	102	4013139	2
15	4019191	1	110	m10451	1
17	4008679	1	115	m03959	1
30	m10454	1			

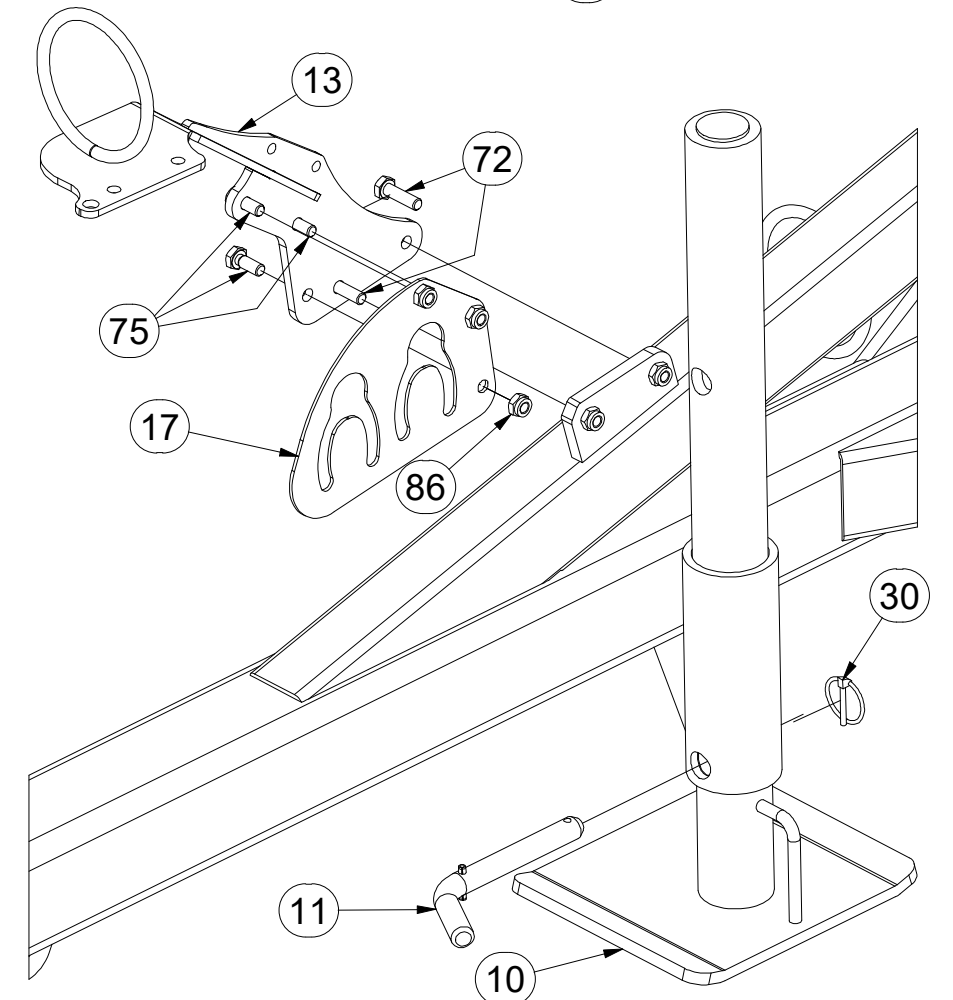
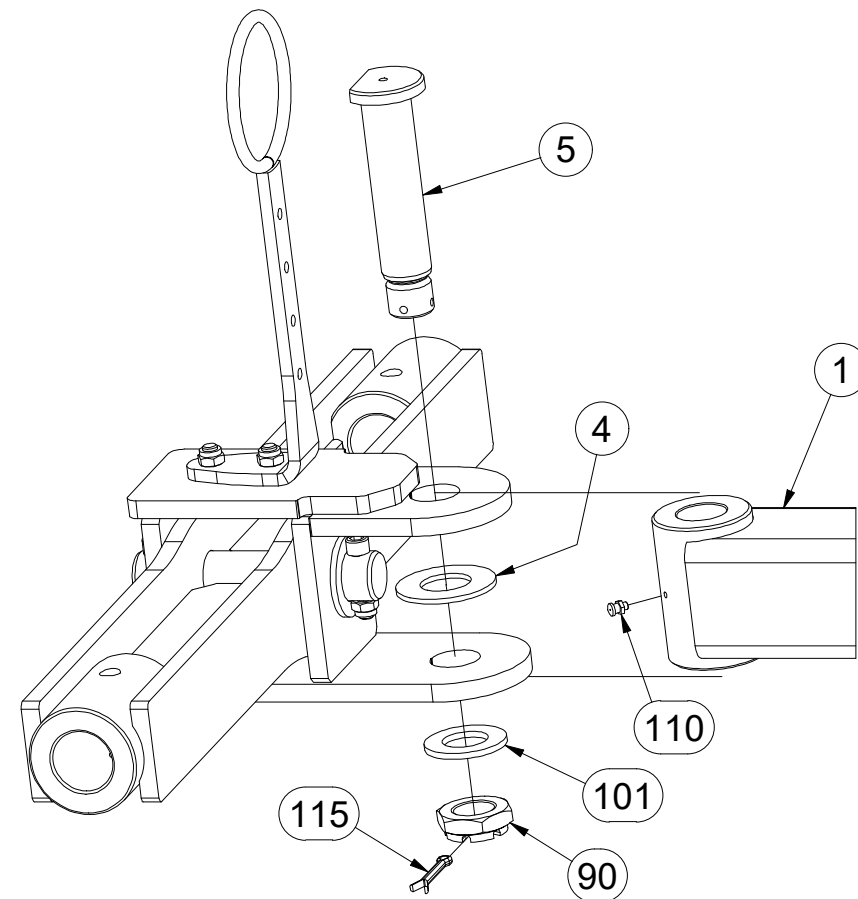
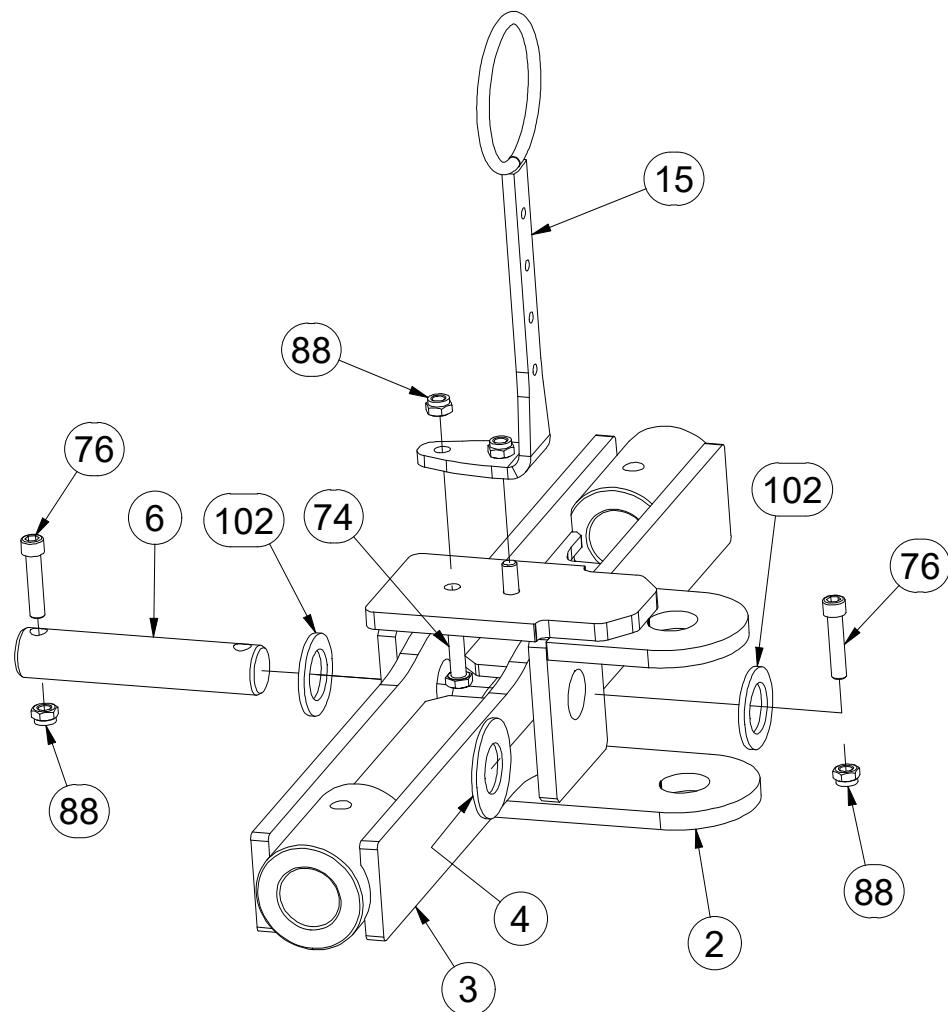
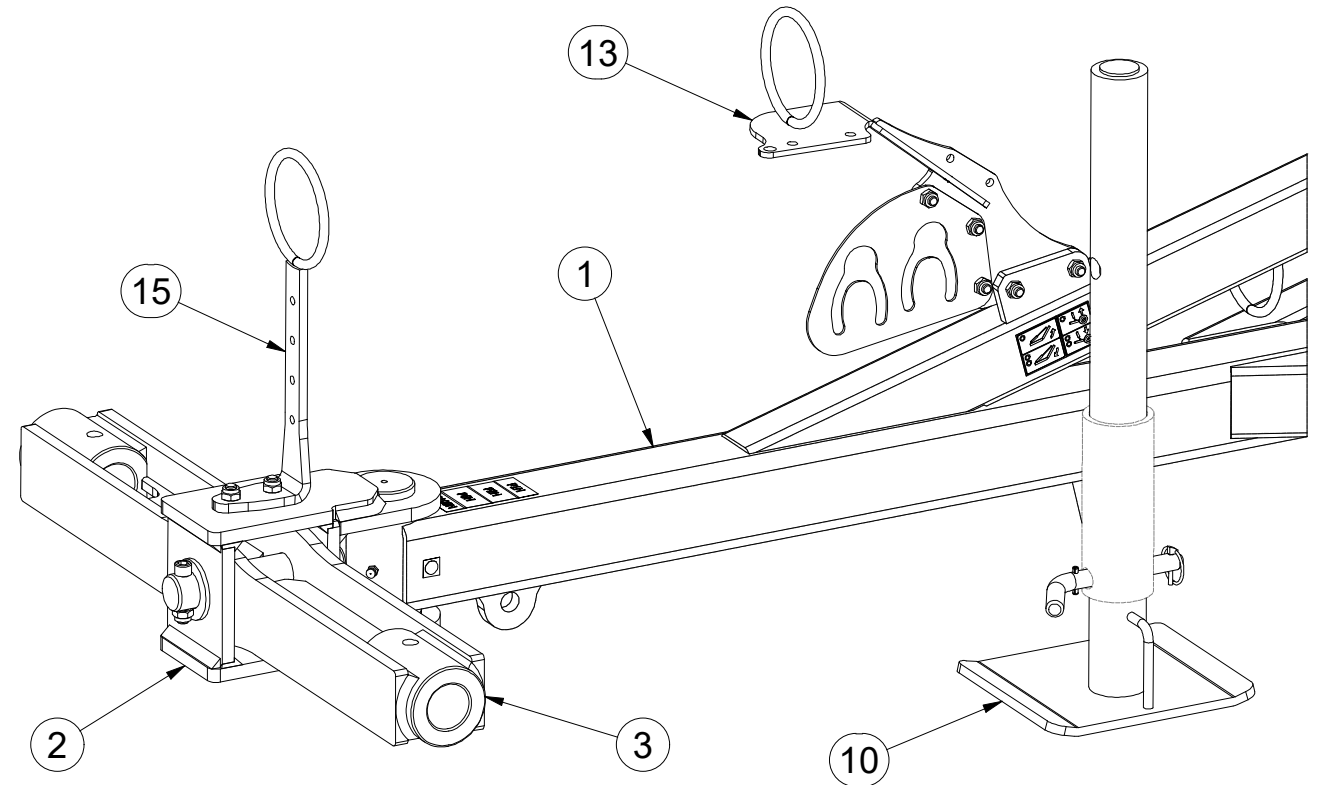

Ⓒ CZ OJ T3

Ⓓ DEICHSEL T3

Ⓕ TIMON T3

Ⓖ GB TOW BAR T3

Ⓔ RU ДЫШЛО T3

Ⓗ PL DYSZEL T3



**3012414**

Pos.	Part Number	Pcs.	Pos.	Part Number	Pcs.
1	2001206	1	73	m04039	4
7	4019255	2	77	m02254	4
8	VZ00024252	1	78	m17098	2
9	VZ00024253	1	85	m05560	4
12	m12296	1	87	m04503	3
14	4013461	1	88	m04301	8
31	m15900	1	89	m01306	4
50	m02579	2	100	m07936	3
70	m01074	2	103	m16612	4
71	m01092	3			

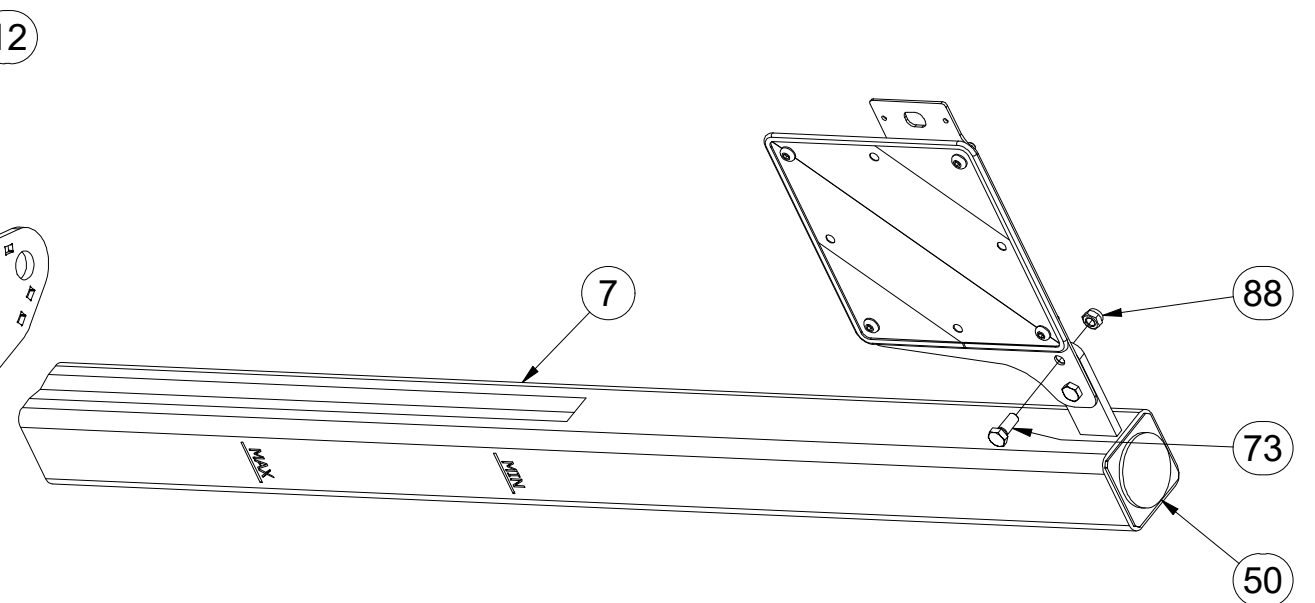
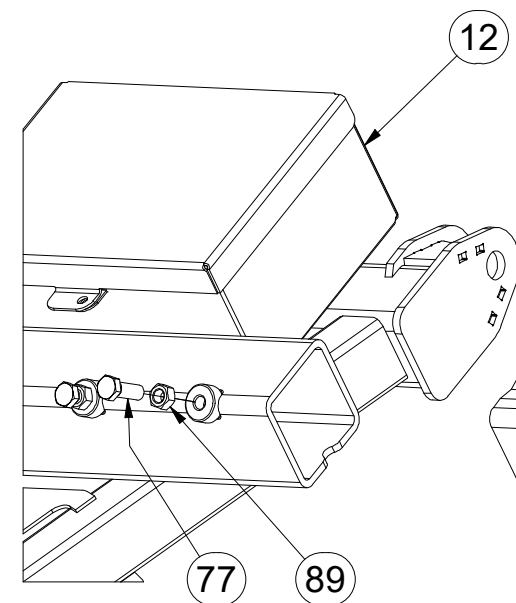
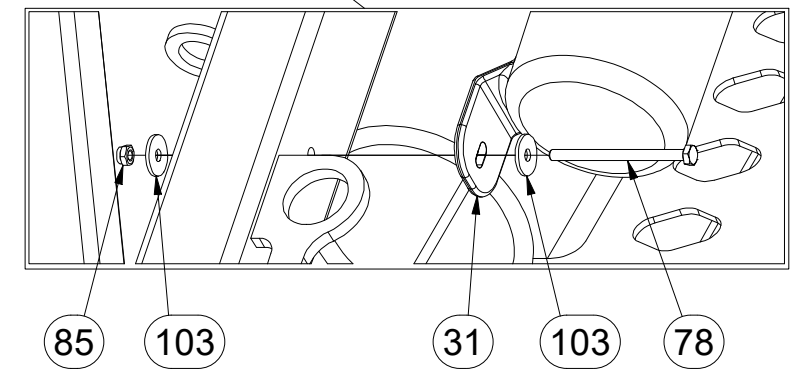
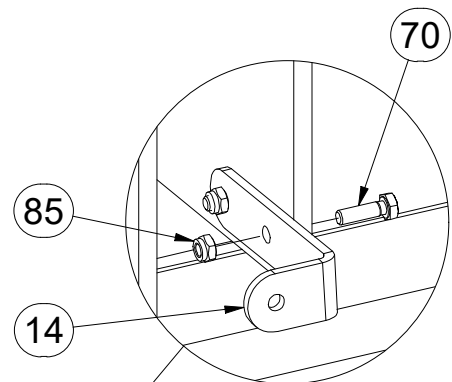
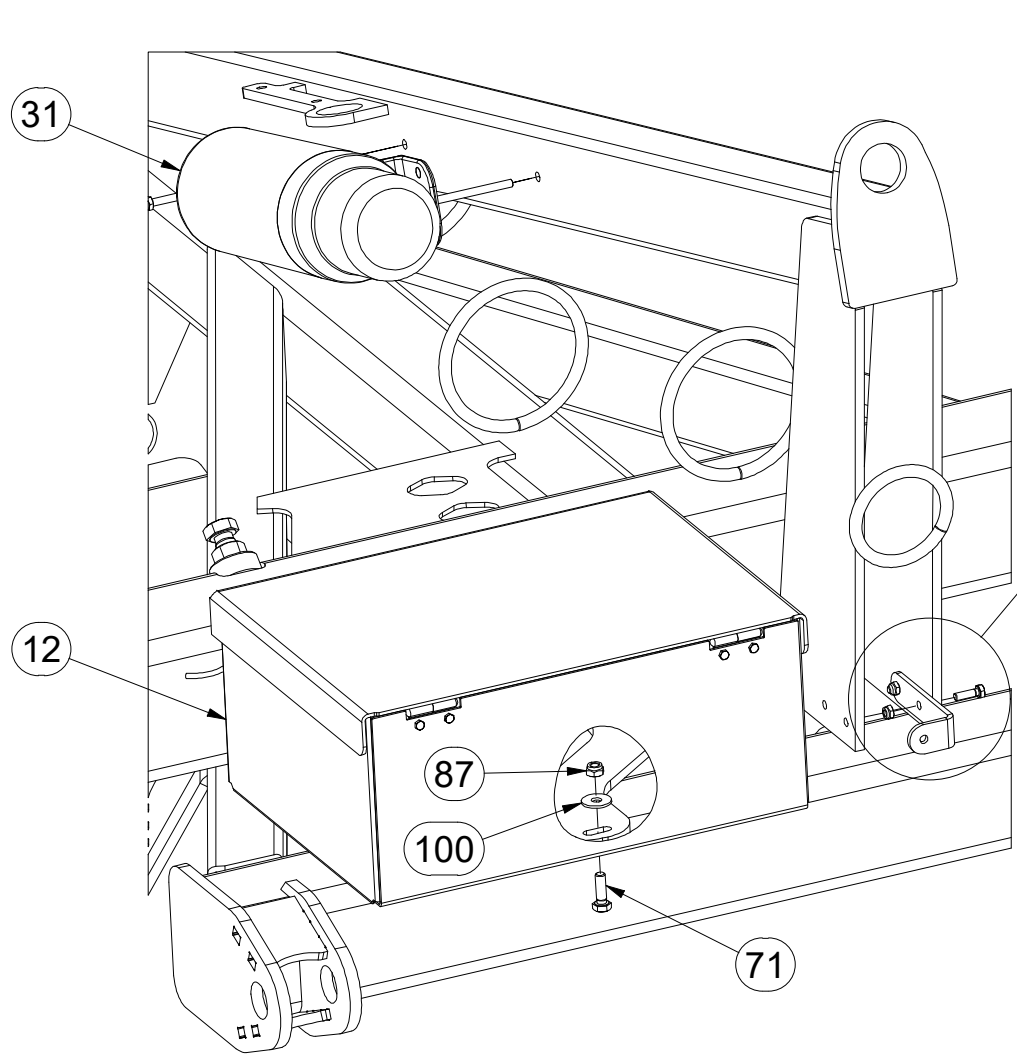
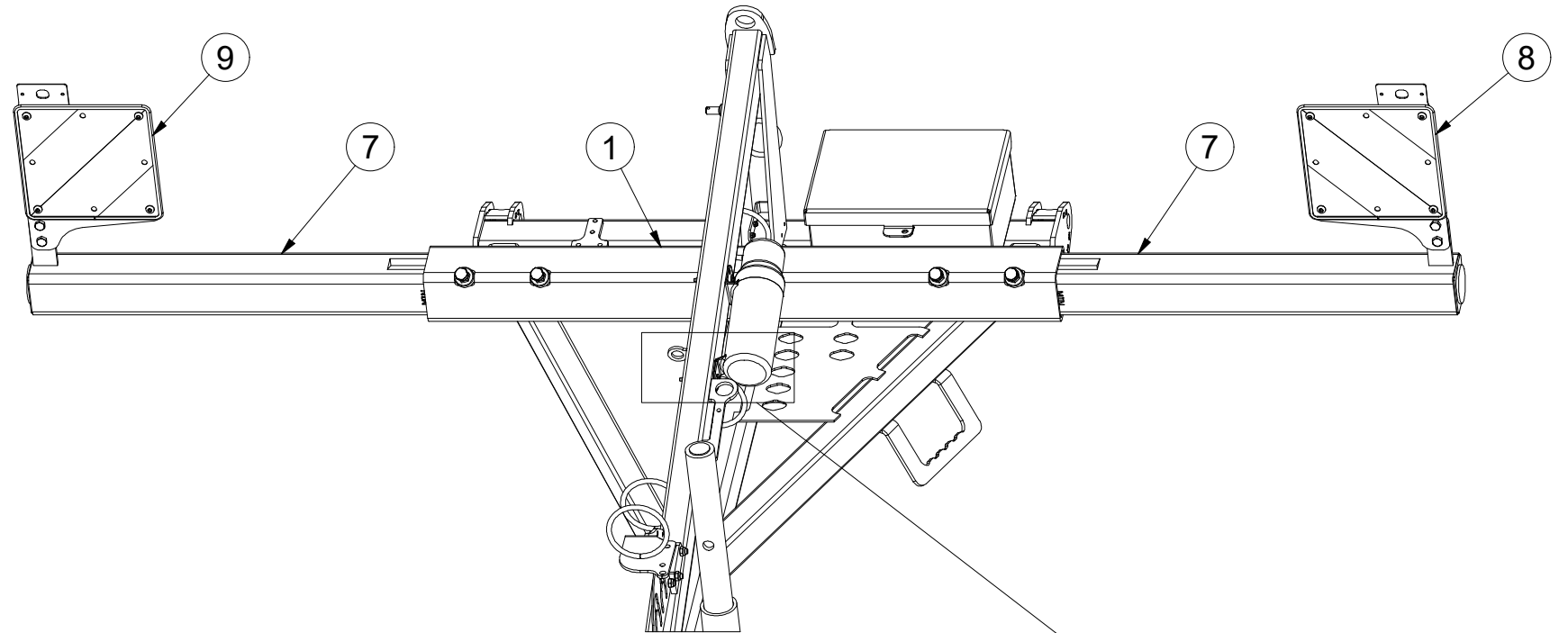

Ⓒ CZ OJ T3

Ⓓ DEICHSEL T3

Ⓕ TIMON T3

**m22709**

Ⓖ GB TOW BAR T3

Ⓡ RU ДЫШЛО T3

Ⓟ PL DYSZEL T3

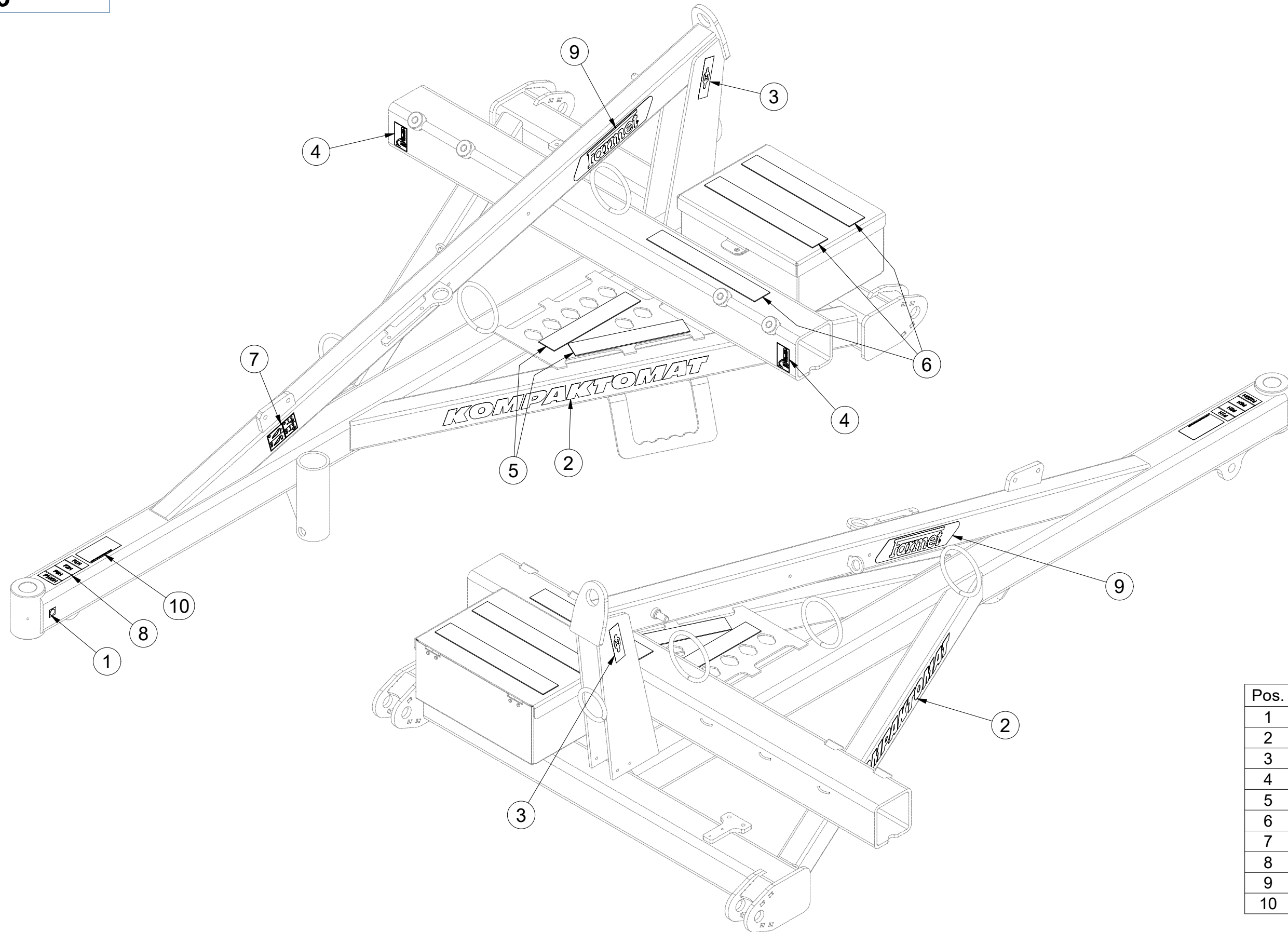

Pos.	Part Number	Pcs.
1	m03320	1
2	m07688	2
3	m03316	2
4	m10180	2
5	m11147	2
6	m11146	3
7	m11291	1
8	m11295	1
9	m13116	2
10	m13708	1

☞ SADA ČEPŮ TBZ 3

☞ BOLZENSATZ TBZ 3

☞ KIT D'EMBOUITS TBZ 3

**3011605**

☞ SET OF TBZ 3 PINS

☞ КОМПЛЕКТ ПАЛЬЦЕВ TBZ 3

☞ ZESTAW CZOPÓW TBZ 3

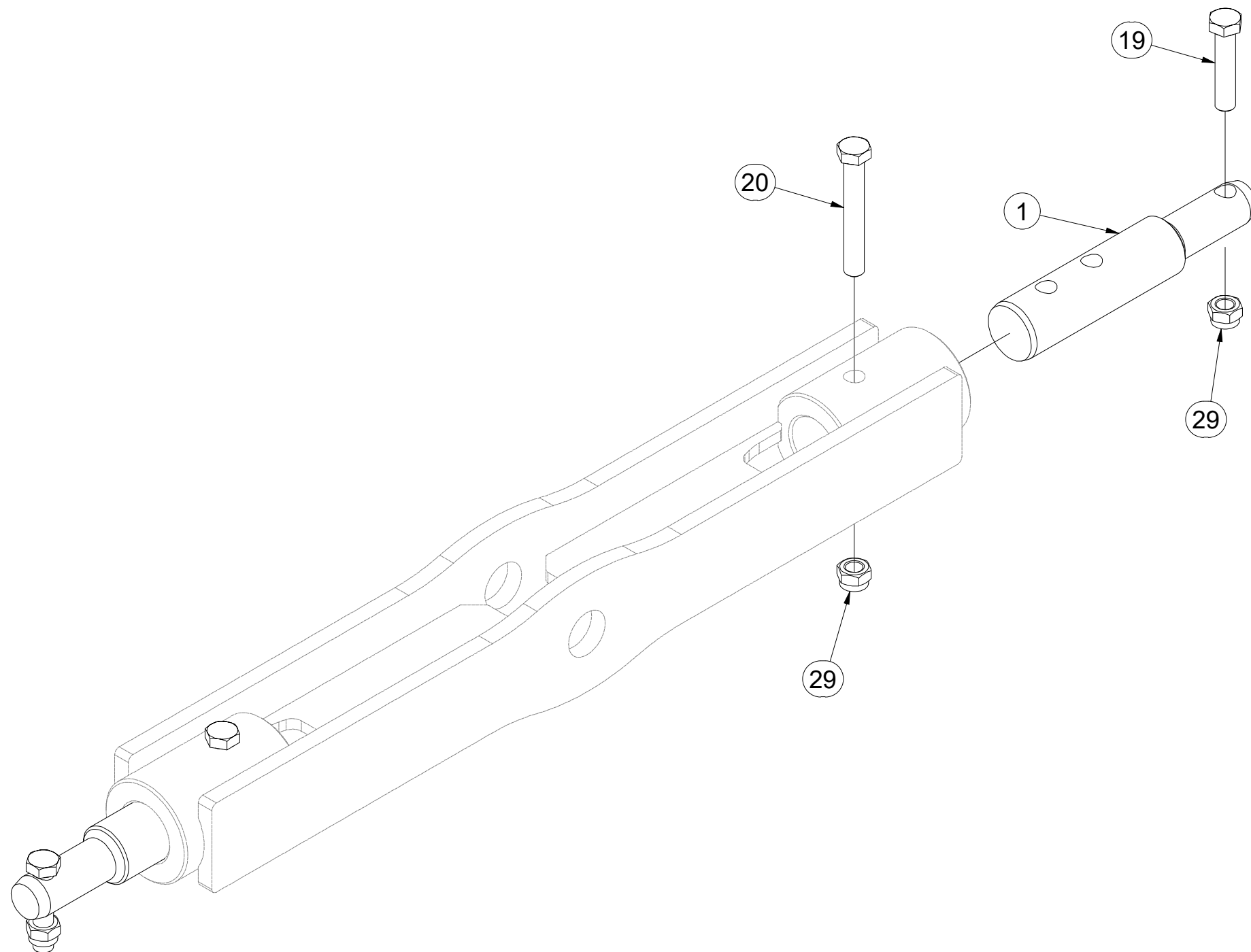
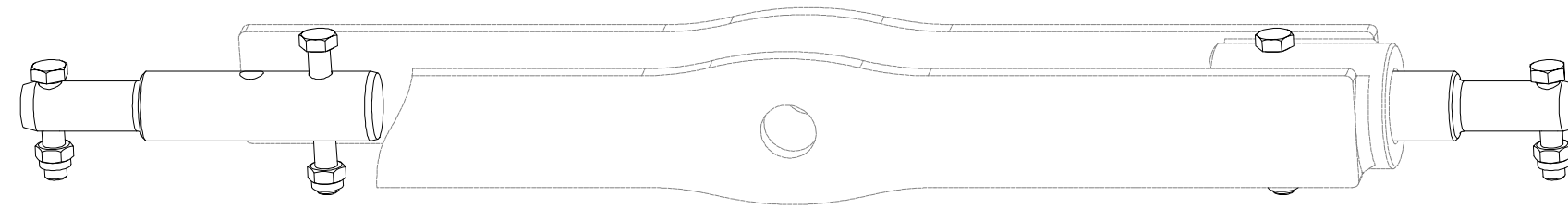

Pos.	Part Number	Pcs.
1	VZ00022884	2
19	m01133	2
20	m02970	2
29	m03683	4

ⒸZ TERČ PŘEDNÍ LEVÝ

Ⓓ SCHILD, VORDERES, LINKES

Ⓕ CIBLE AVANT GAUCHE

ⒸB LEFT FRONT DISC

ⒸU ЩИТОК ПЕРЕДНИЙ ЛЕВЫЙ

ⒸL TARCZA PRZEDNIA LEWA



**VZ00024252**

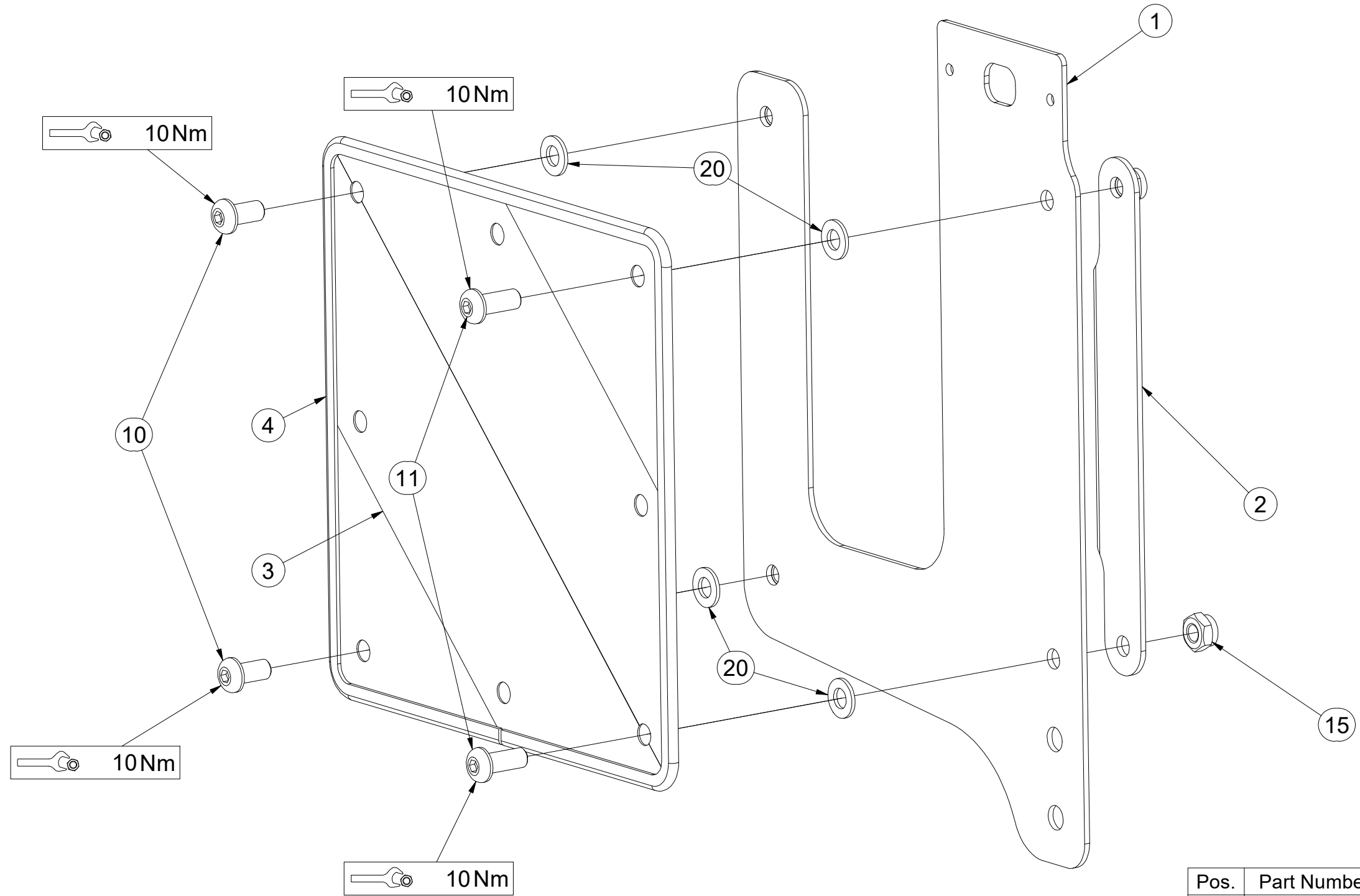

Pos.	Part Number	Pcs.
1	VZ00024254	1
2	VZ00024261	1
3	m18855	1
4	9005707	1
10	m16637	2
11	m16688	2
15	m03775	4
20	m01209	4

ⒸZ TERČ PŘEDNÍ PRAVÝ

Ⓓ SCHILD, VORDERES, RECHTES

Ⓕ CIBLE AVANT DROITE

ⒸB RIGHT FRONT DISC

ⒸU ЩИТОК ПЕРЕДНИЙ ПРАВЫЙ

ⒸL TARCZA PRZEDNIA PRAWA



**VZ00024253**

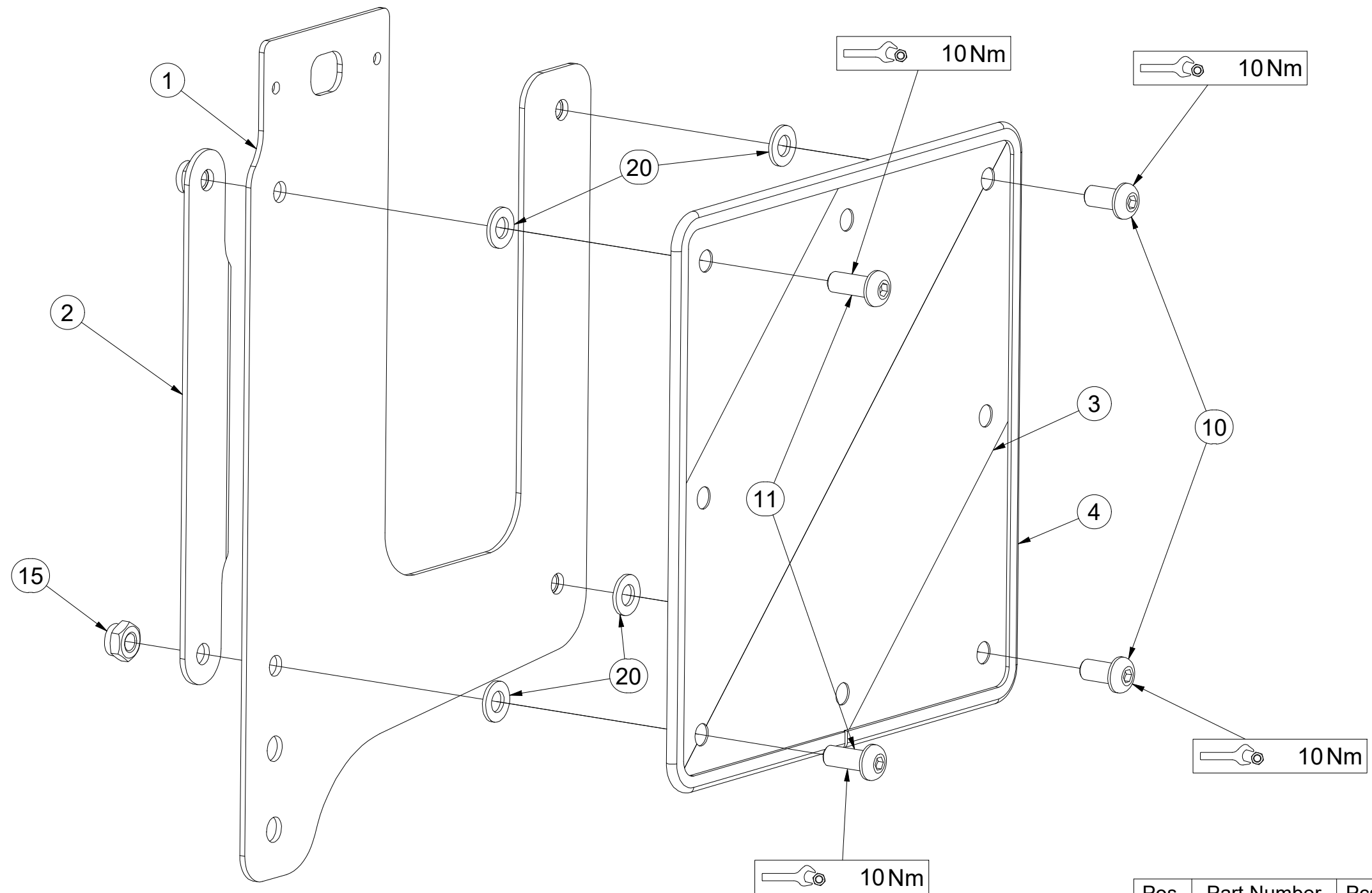

Pos.	Part Number	Pcs.
1	VZ00024254	1
2	VZ00024261	1
3	m18855	1
4	9005707	1
10	m16637	2
11	m16688	2
15	m03775	4
20	m01209	4



Ⓒ SADA KYPŘIČŮ STOP

Ⓓ SPURENLOCKERERSATZ

Ⓕ KIT DE CULTIVATEURS DE TRACES

**3005535**

Ⓖ SET OF TRACK CULTIVATORS

Ⓡ КОМПЛЕКТ РЫХЛИТЕЛЕЙ КОЛЕИ

Ⓟ ZESTAW SPULCHNIACZY ŚLADÓW

**Farmet**

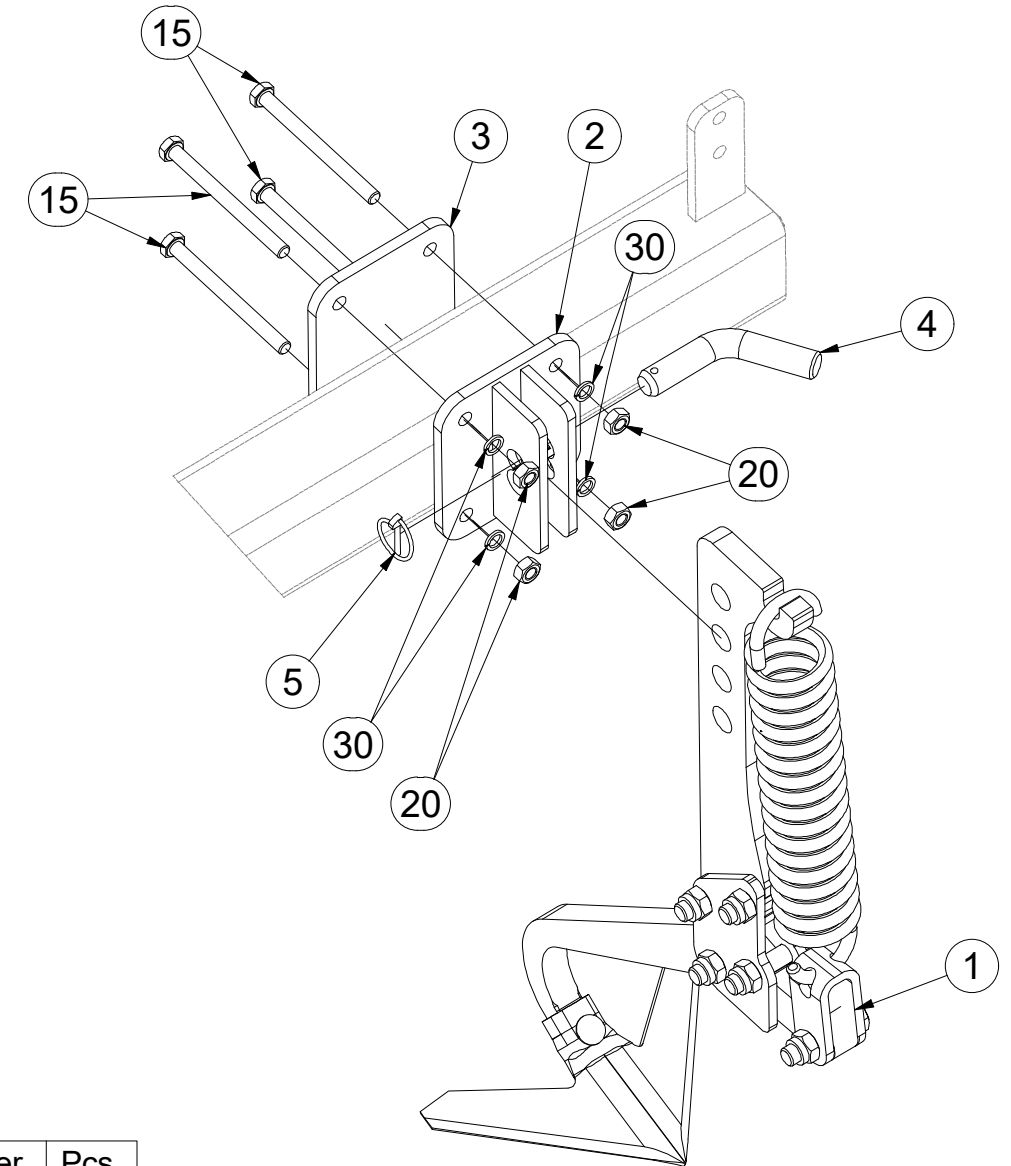
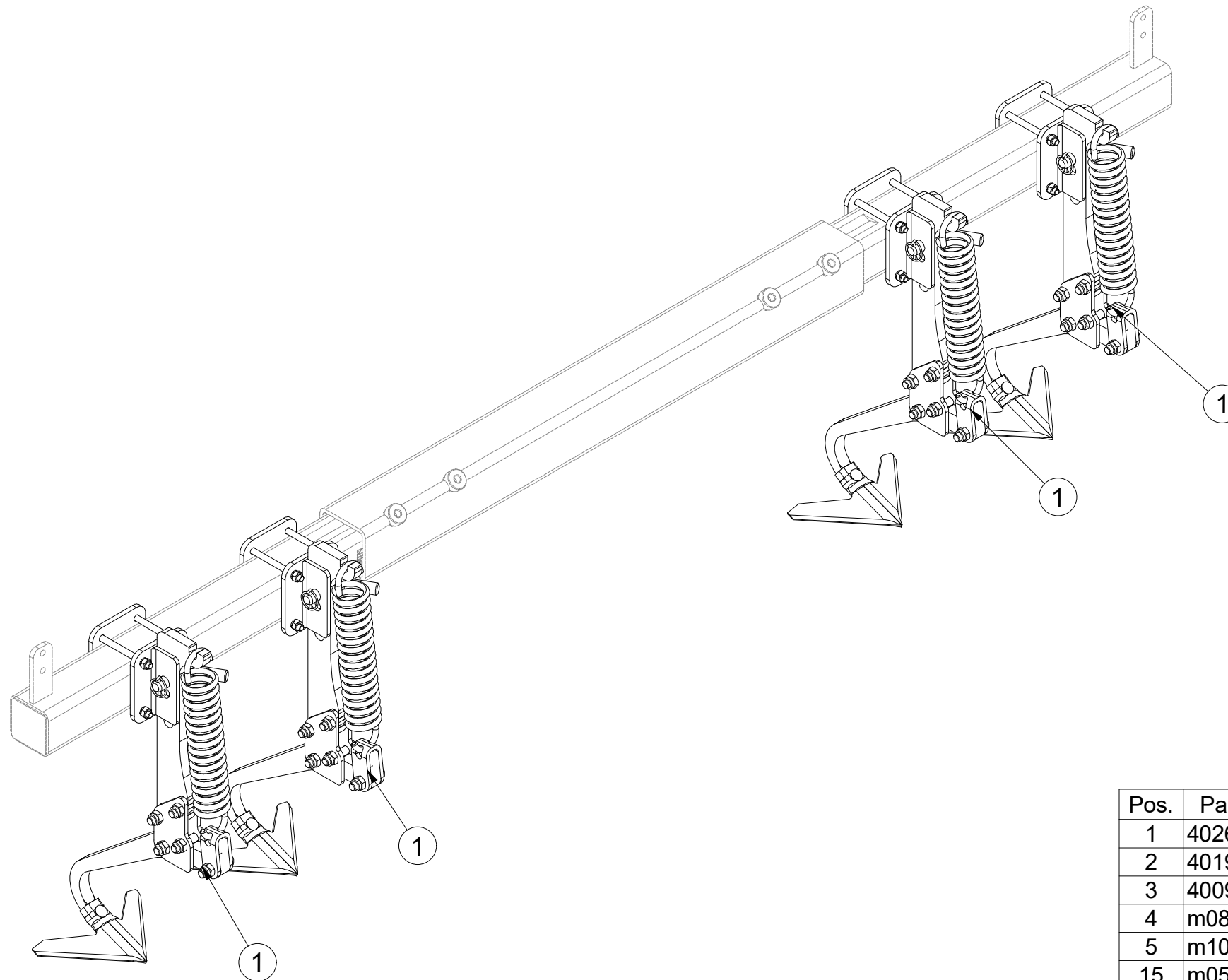

Pos.	Part Number	Pcs.
1	4026045	4
2	4019042	4
3	4009468	4
4	m08885	4
5	m10454	4
15	m05946	16
20	m01305	16
30	m03988	16

Ⓒ KYPŘIČ STOP

Ⓓ SPURENLOCKERER

Ⓕ CULTIVATEUR DES TRACES

Ⓖ TRACK CULTIVATOR

Ⓡ РУХЛИТЕЛЬ КОЛЕИ

Ⓟ SPULCHNIARKA STÓP



**4026045**

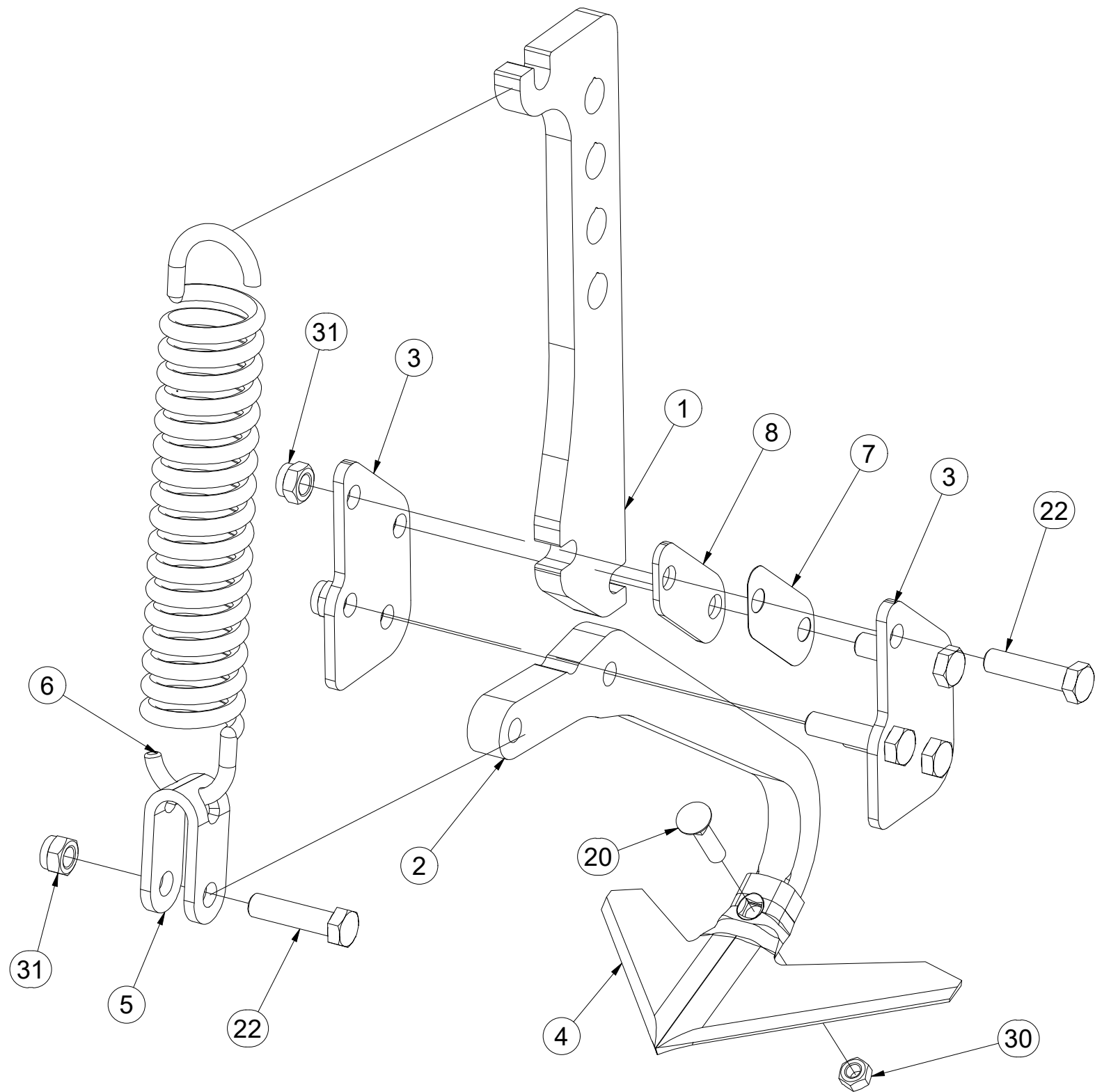
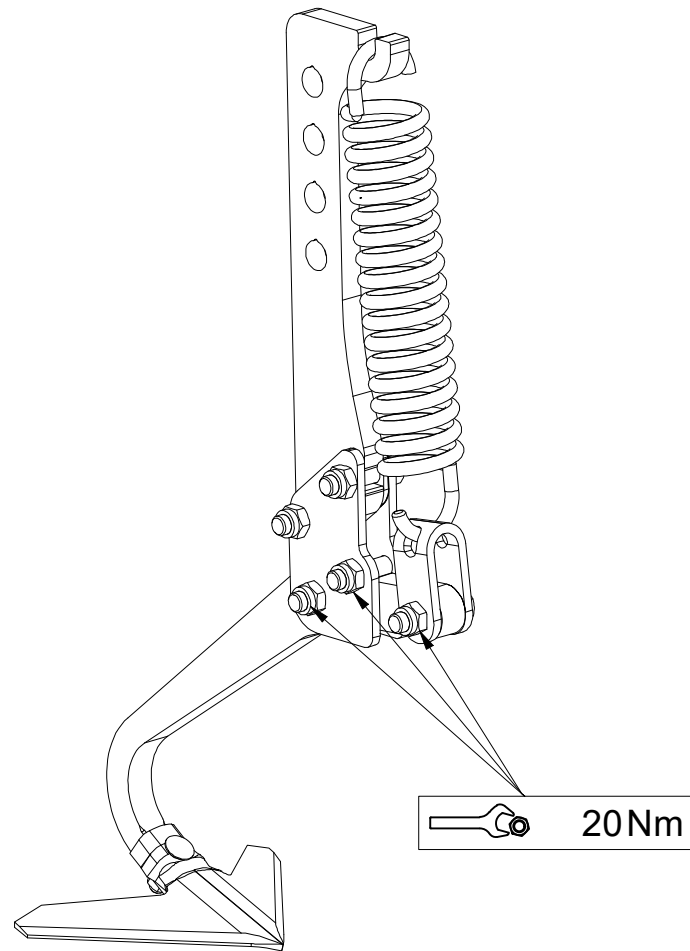

Pos.	Part Number	Pcs.
1	4017307	1
2	4025591	1
3	4005582	2
4	3000236-KOO	1
5	4005445	1
6	m02597	1
7	4005591	1
8	4026202	1
20	m10440	1
22	m06587	5
30	m10439	1
31	m03683	5

ⒸZ SADA PŘEDNÍCH SMYKŮ

Ⓓ SATZ VORDERE ACKERSCHLEPPEN

Ⓕ KIT DE NIVELEURS AVANT

**3006165**

ⒸB SET OF FRONT LEVELLING BARS

Ⓔ КОМПЛЕКТ ПЕРЕДНИХ БОРОН

Ⓗ ZESTAW PRZEDNICH WŁÓK

**Farmet**

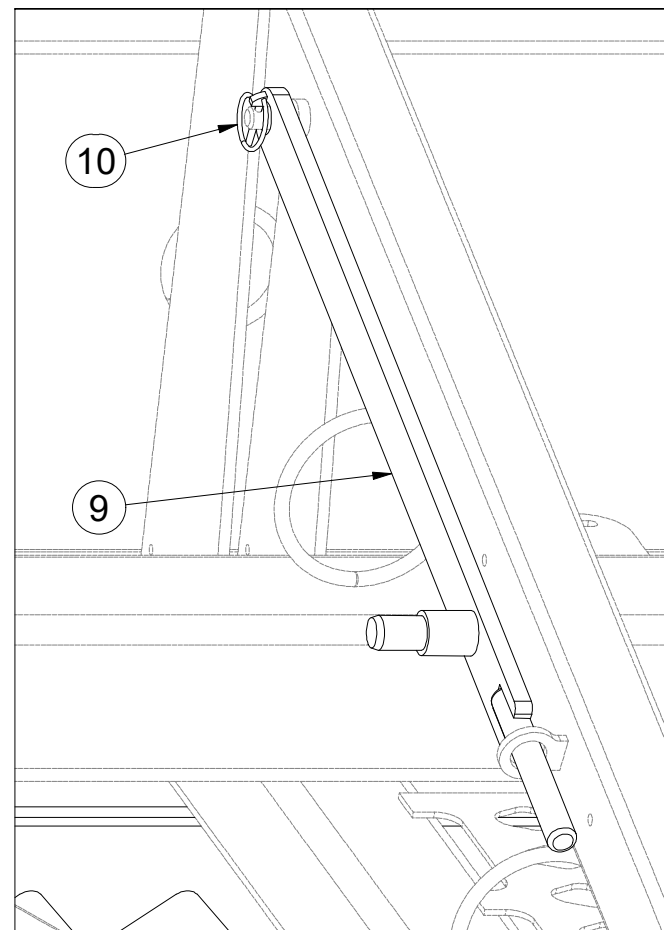
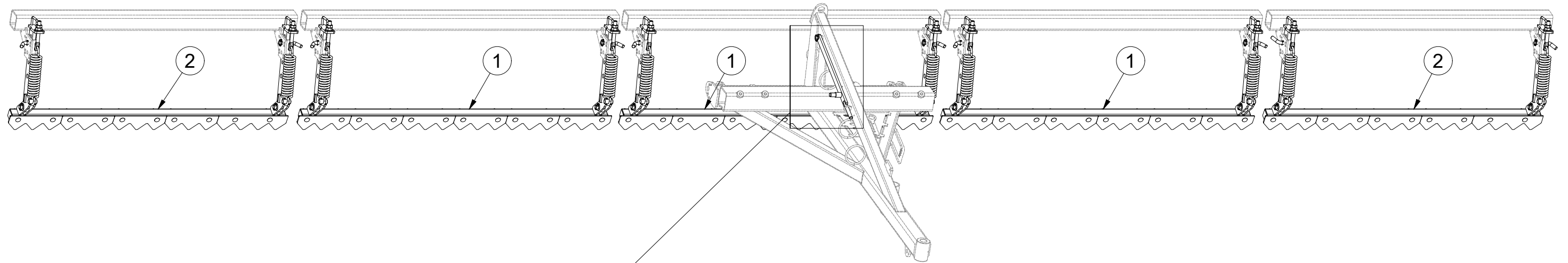

Pos.	Part Number	Pcs.
1	VZ00003364	3
2	VZ00027777	2
9	4006829	1
10	m10454	11

Ⓒ SADA PŘEDNÍCH SMYKŮ

Ⓓ SATZ VORDERE ACKERSCHLEPPEN

Ⓕ KIT DE NIVELEURS AVANT

Ⓖ SET OF FRONT LEVELLING BARS

Ⓡ КОМПЛЕКТ ПЕРЕДНИХ БОРОН

Ⓟ ZESTAW PRZEDNICH WŁÓK



**3006165**

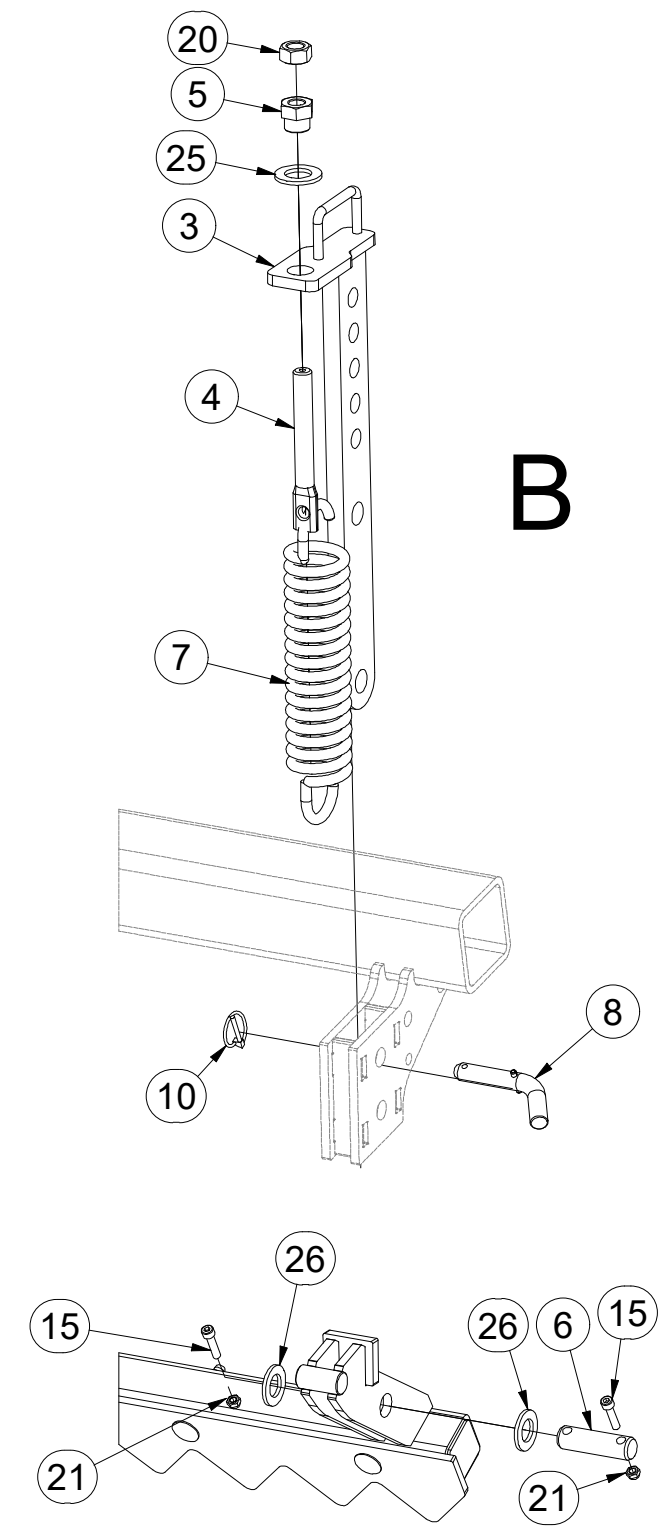
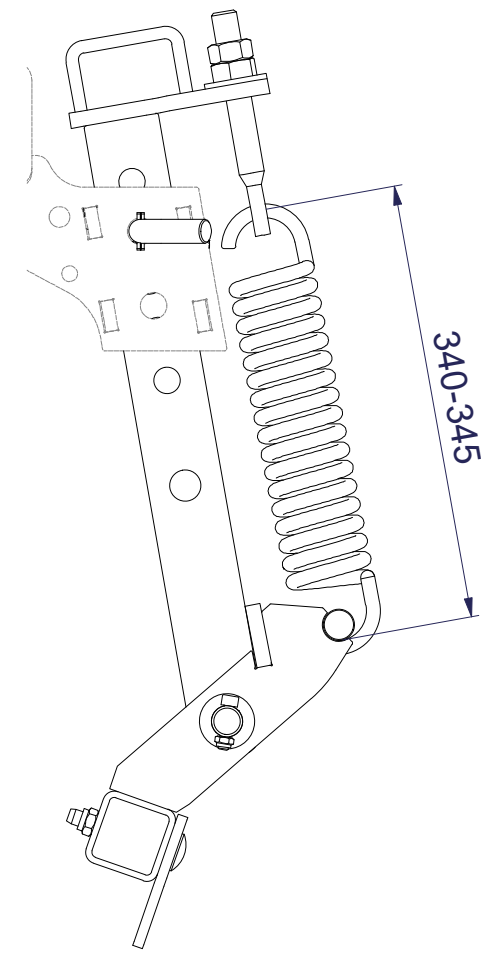
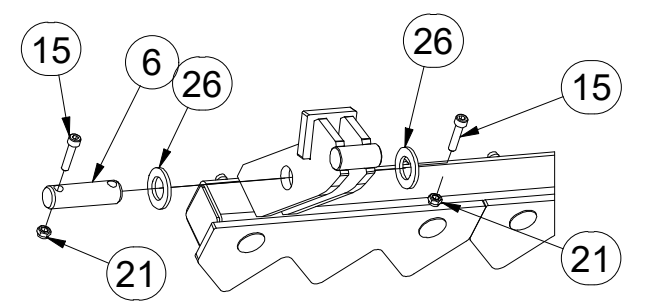
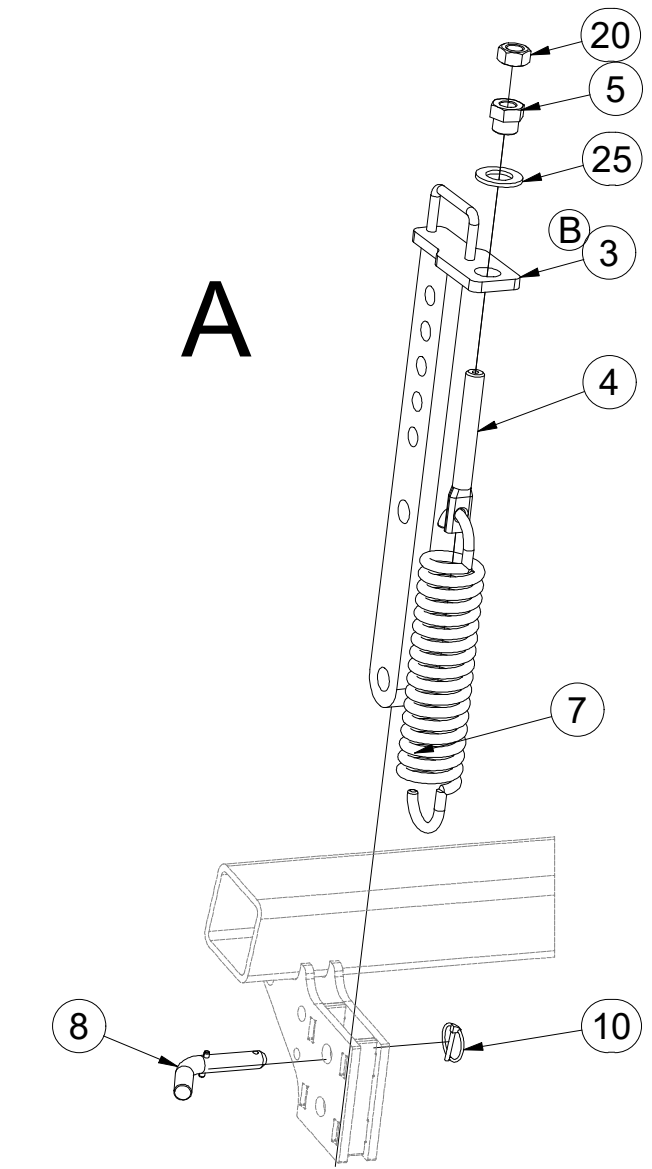
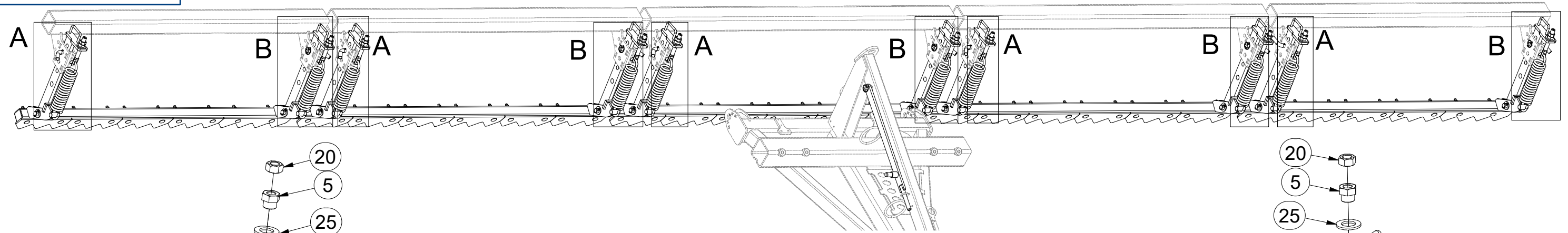

Pos.	Part Number	Pcs.
3	3008686	10
4	4003401	10
5	4000189	10
6	4010390	10
7	m02597	10
8	4012011	10
10	m10454	11
15	m09464	20
20	m01307	10
21	m04503	20
25	m01225	10
26	m14028	20

Ⓒ PŘEDNÍ SMYK

Ⓓ VORDERE ACKERSCHLEIFE

Ⓕ NIVELEUR AVANT

Ⓖ FRONT DRAG

Ⓡ ПЕРЕДНЯЯ БОРОНА

Ⓟ PRZEDNIA WŁÓKA

**Farmet**

**VZ00003364**

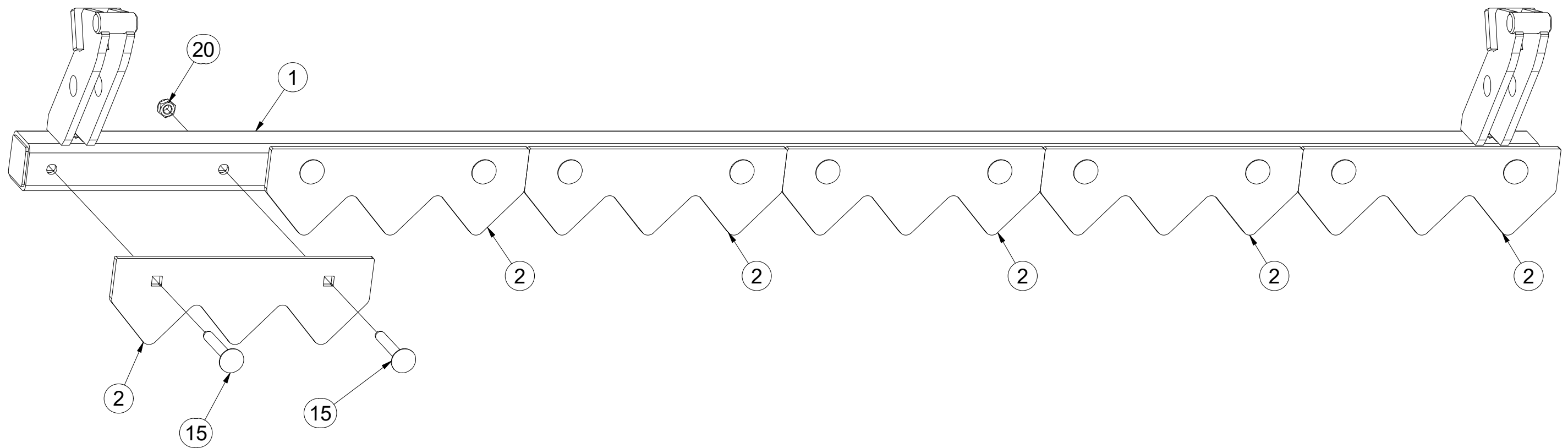
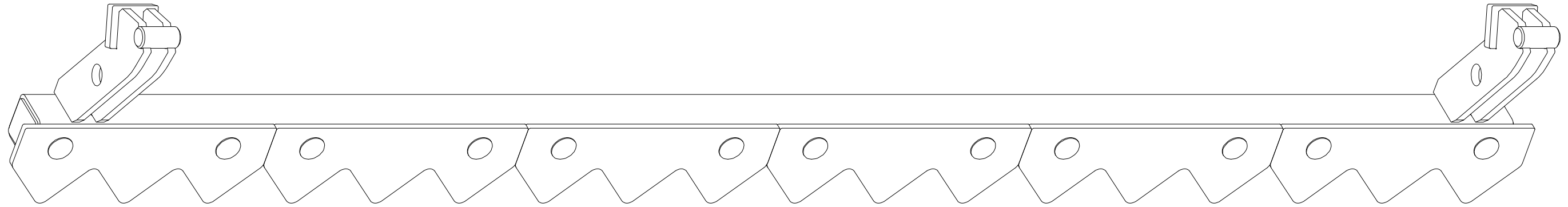

Pos.	Part Number	Pcs.
1	VZ00003365	1
2	VZ00003366	6
15	m08339	12
20	m04301	12

Ⓒ PŘEDNÍ SMYK

Ⓓ VORDERE ACKERSCHLEIFE

Ⓕ NIVELEUR AVANT

Ⓖ FRONT DRAG

Ⓔ ПЕРЕДНЯЯ БОРОНА

Ⓟ PRZEDNIA WŁÓKA

**Farmet**

**VZ00027777**

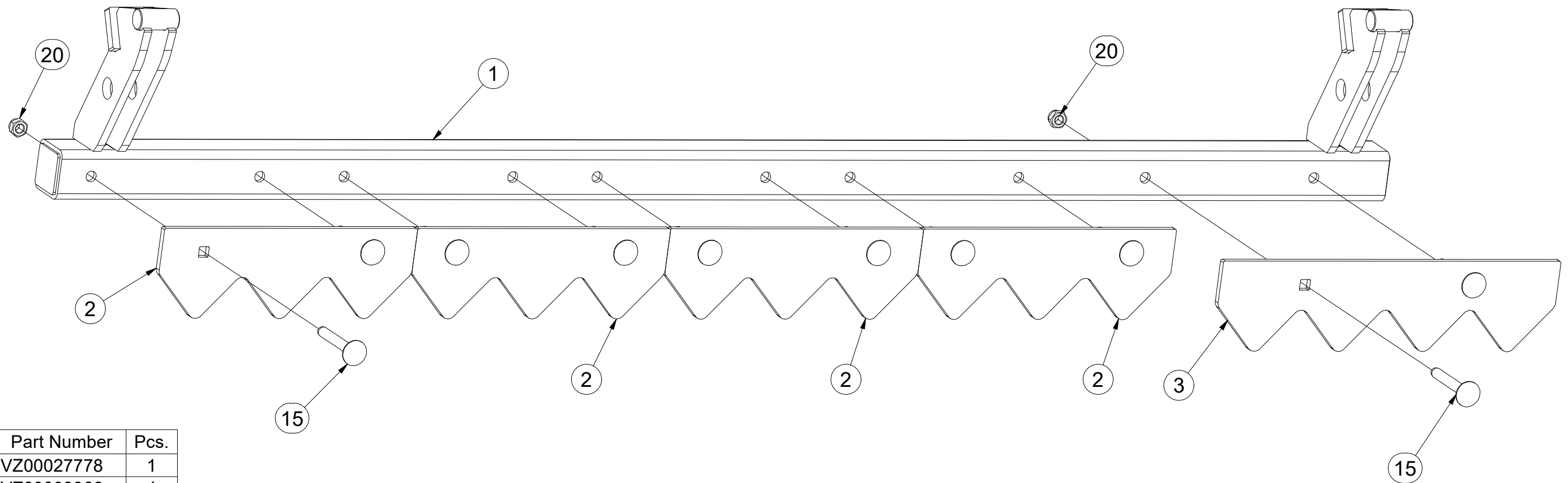
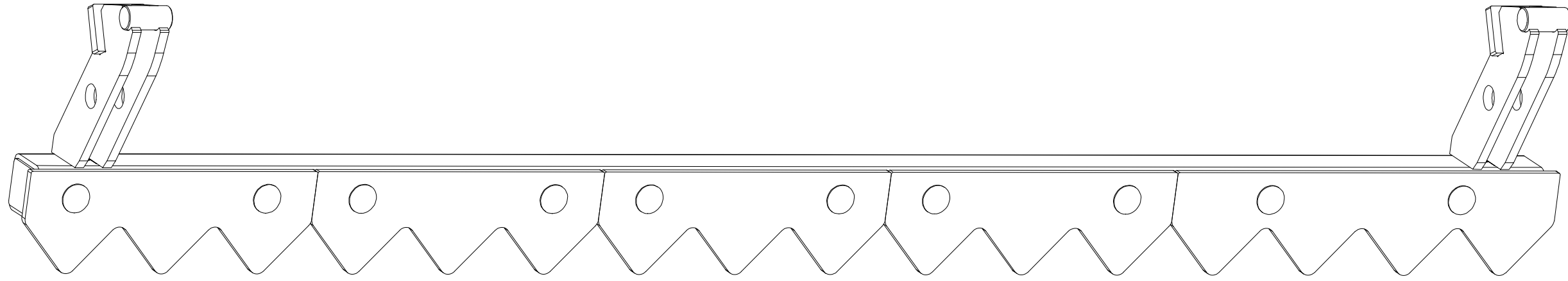

Pos.	Part Number	Pcs.
1	VZ00027778	1
2	VZ00003366	4
3	VZ00011193	1
15	m08339	10
20	m04301	10

ⒸZ SADA PŘEDNÍCH VÁLCŮ

Ⓓ SATZ VORDERE WALZEN

Ⓕ KIT DE ROULEAUX AVANT

ⒸB SET OF FRONT ROLLERS

ⒸU КОМПЛЕКТ ПЕРЕДНИХ КАТКОВ

ⒸL ZESTAW PRZEDNICH WAŁÓW



**3011905**

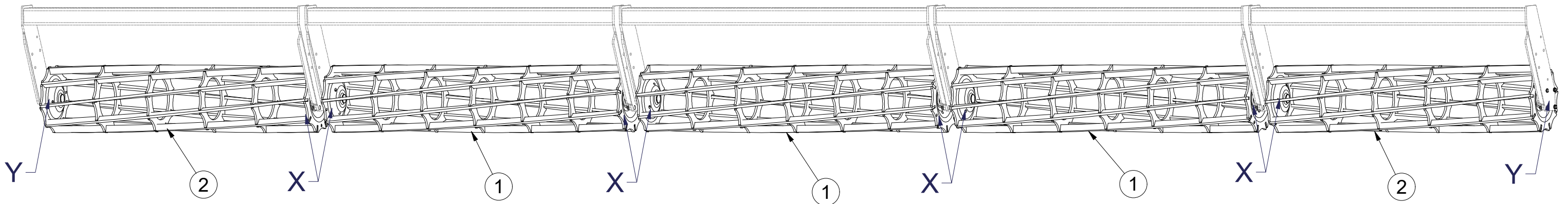

Pos.	Part Number	Pcs.	Pos.	Part Number	Pcs.
1	2000679	3	12	m06077	4
2	2001153	2	20	m01305	40
10	m03519	32	25	m17741	4
11	m03339	4	26	m03988	40

X

Y

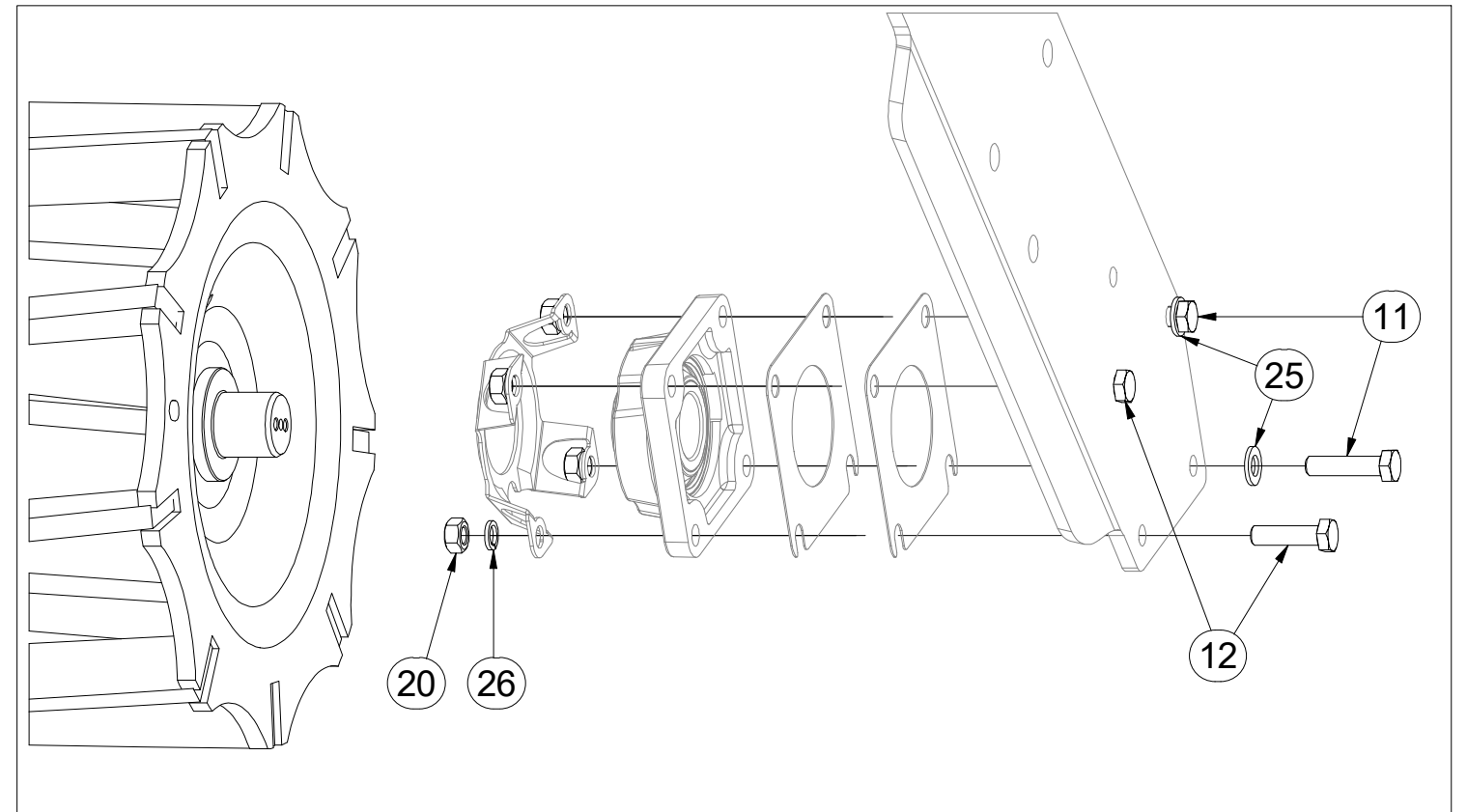
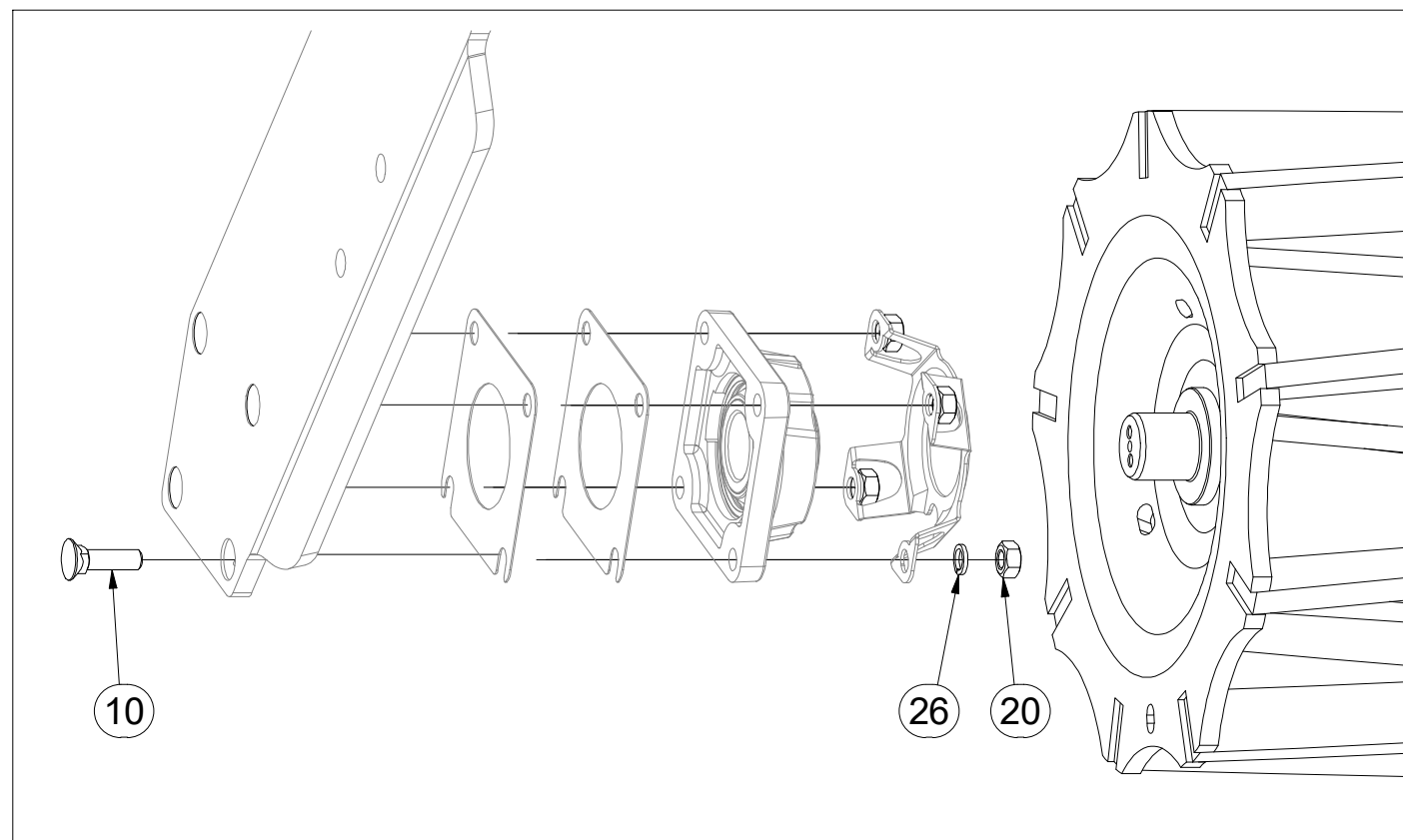

- Ⓒ SADA LOŽISEK
- Ⓓ SATZ LAGER
- Ⓕ KIT DE ROULEMENTS

- Ⓖ SET OF BEARINGS
- Ⓡ КОМПЛЕКТ ПОДШИПНИКОВ
- Ⓟ ZESTAW ŁOŻYSK



**VZ00012472**

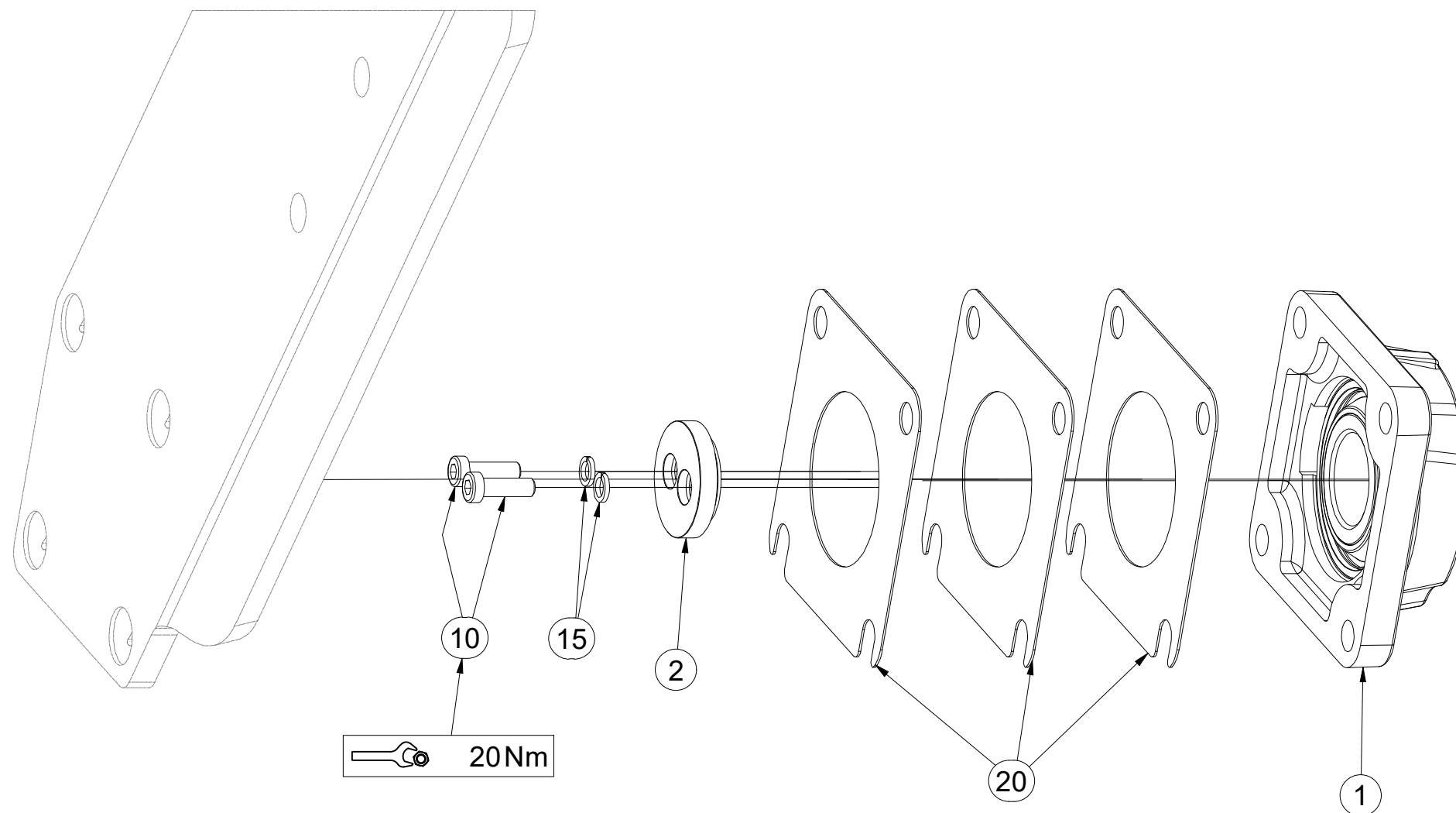
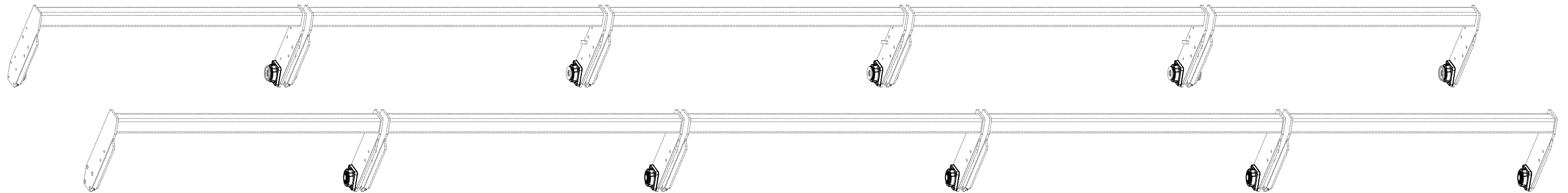

Pos.	Part Number	Pcs.
1	m18650	20
2	4024753	20
10	m23338	40
15	m01202	40
20	4016809	60



CZ SADA OVLÁDÁNÍ RADLIC  
 D STEUERSATZ PFLUGSCHAREN  
 F KIT DE COMMANDE DES SOCS

GB SET OF PLOUGHSHARE CONTROL  
 RU КОМПЛЕКТ УПРАВЛЕНИЯ ЛАП  
 PL ZESTAW STEROWANIA RADLICAMI



**3011970**

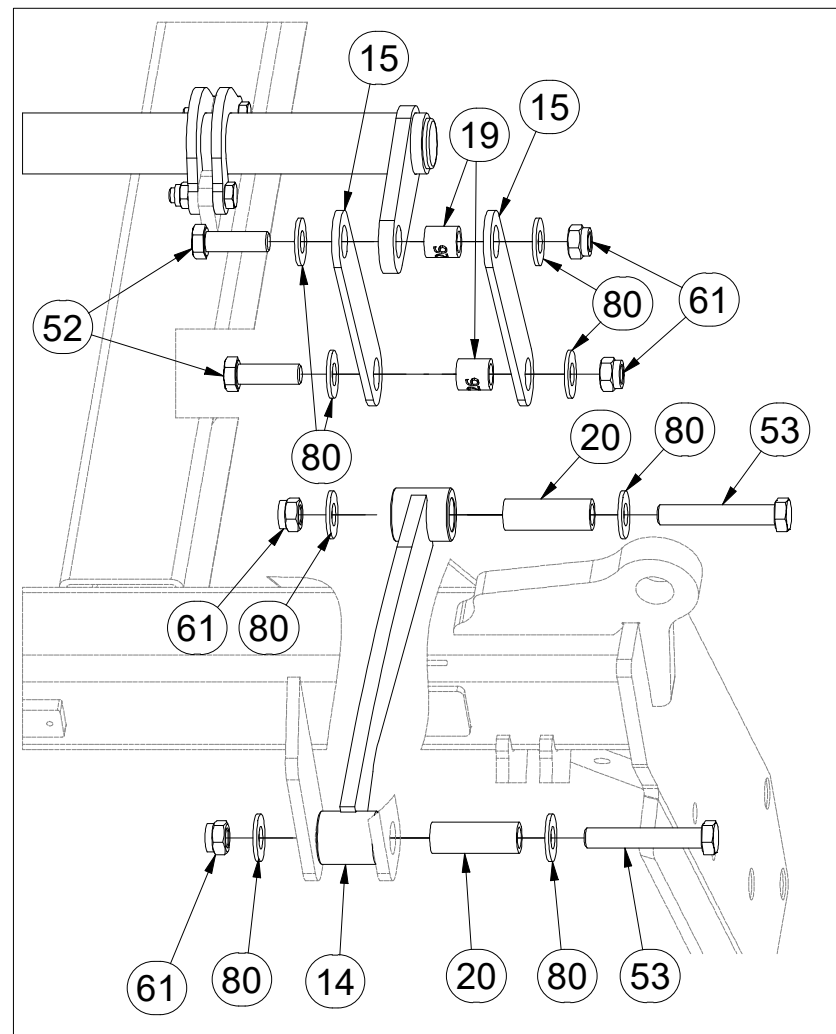
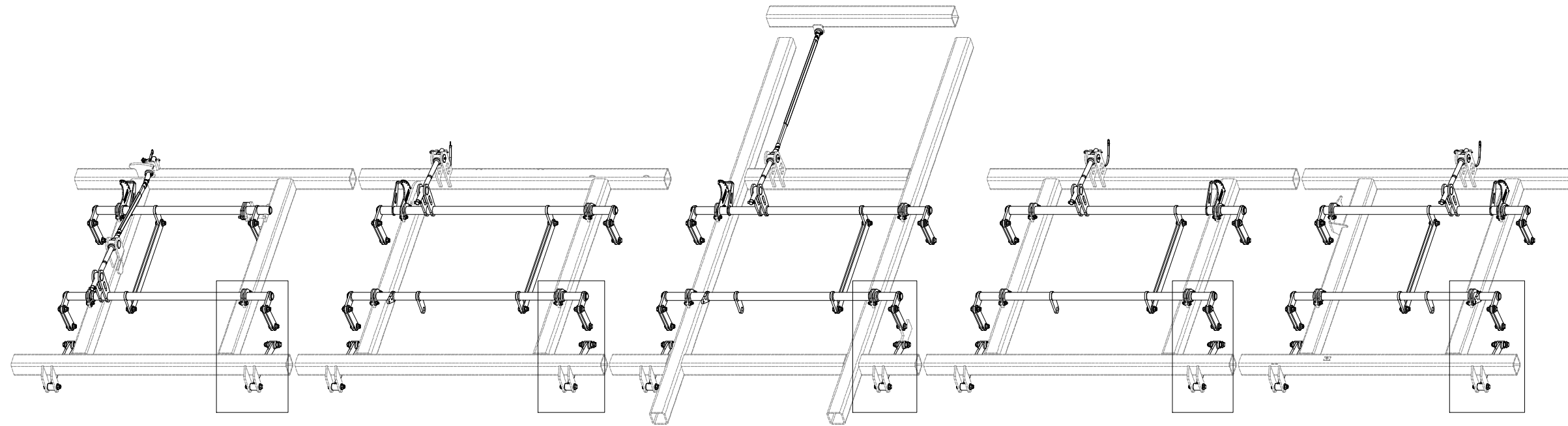

Pos.	Part Number	Pcs.
14	VZ00003342	10
15	4005333	40
19	4002265	50
20	9001426	20
52	m04355	50
53	m07673	20
61	m03683	70
80	m05651	140

CZ SADA OVLÁDÁNÍ RADLIC  
 D STEUERSATZ PFLUGSCHAREN  
 F KIT DE COMMANDE DES SOCS

GB SET OF PLOUGHSHARE CONTROL  
 RU КОМПЛЕКТ УПРАВЛЕНИЯ ЛАП  
 PL ZESTAW STEROWANIA RADLICAMI



**3011970**

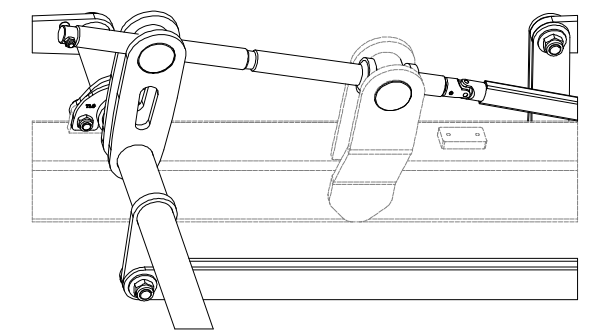
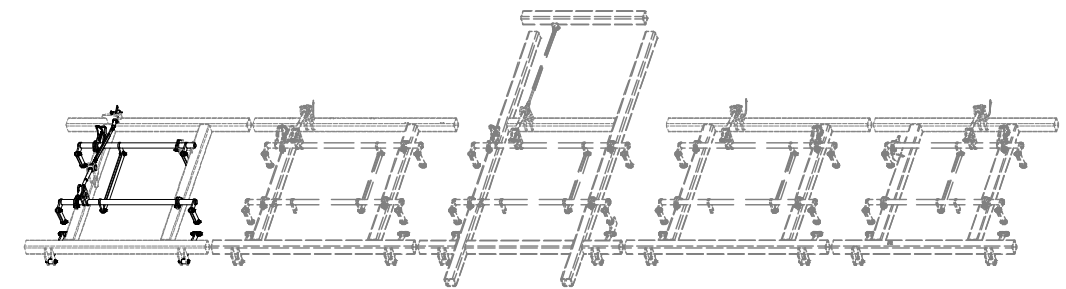
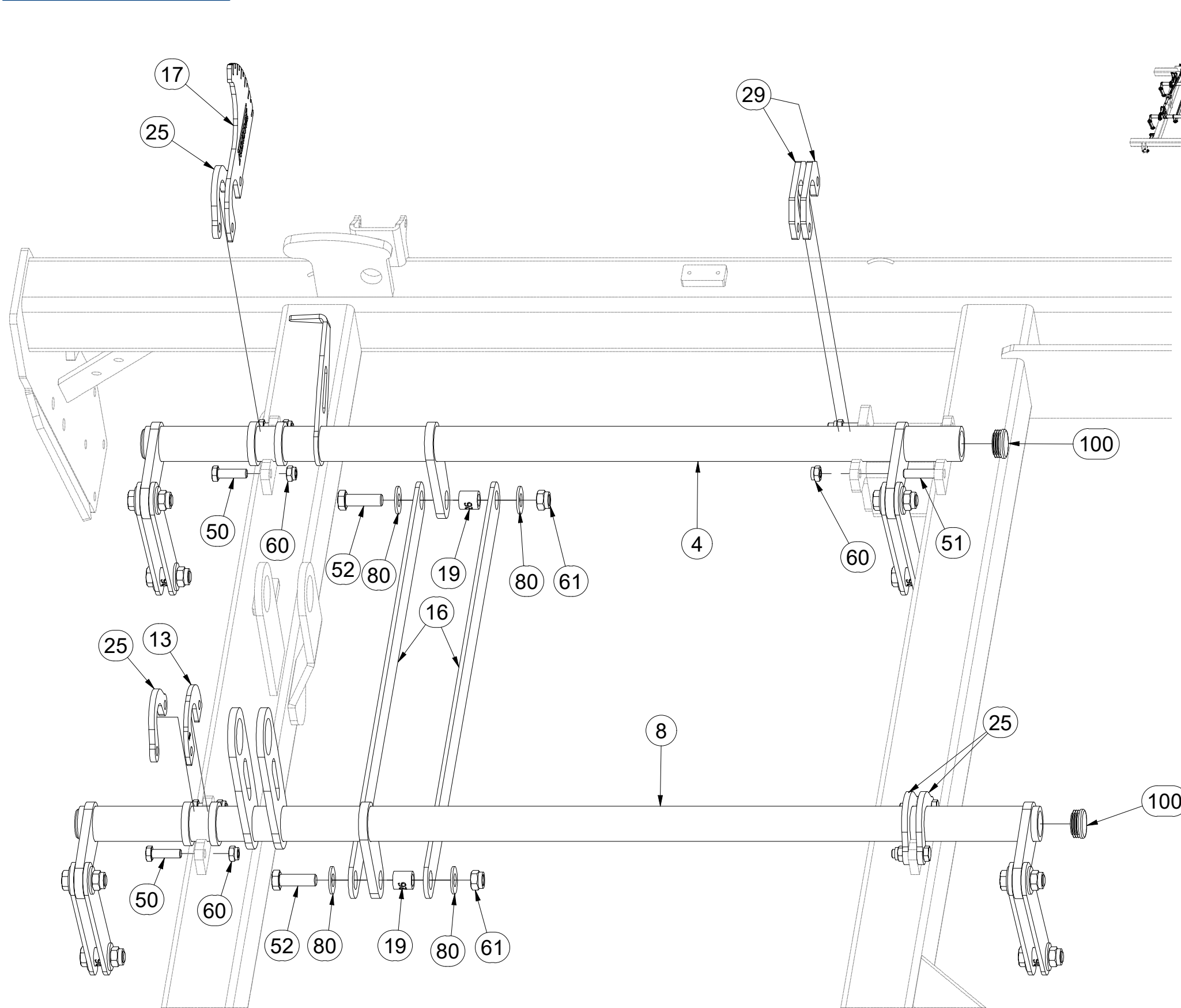

Pos.	Part Number	Pcs.	Pos.	Part Number	Pcs.
4	3011344	1	50	m03926	14
8	3011343	1	51	m06077	26
13	4023488	1	52	m04355	50
16	4005334	10	60	m04301	40
17	4023896	5	61	m03683	70
19	4002265	50	80	m05651	140
25	4005332	32	100	m10130	20
29	4023556	2			

Ⓒ SADA OVLÁDÁNÍ RADLIC

Ⓓ STEUERSATZ PFLUGSCHAREN

Ⓕ KIT DE COMMANDE DES SOCS

Ⓖ SET OF PLOUGHSHARE CONTROL

Ⓡ КОМПЛЕКТ УПРАВЛЕНИЯ ЛАП

Ⓢ ZESTAW STEROWANIA RADLICAMI



3011970

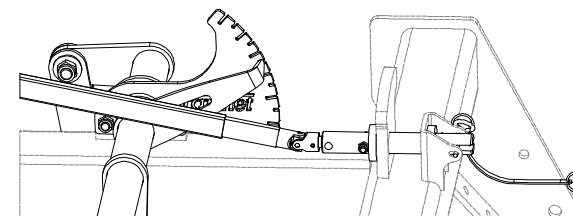
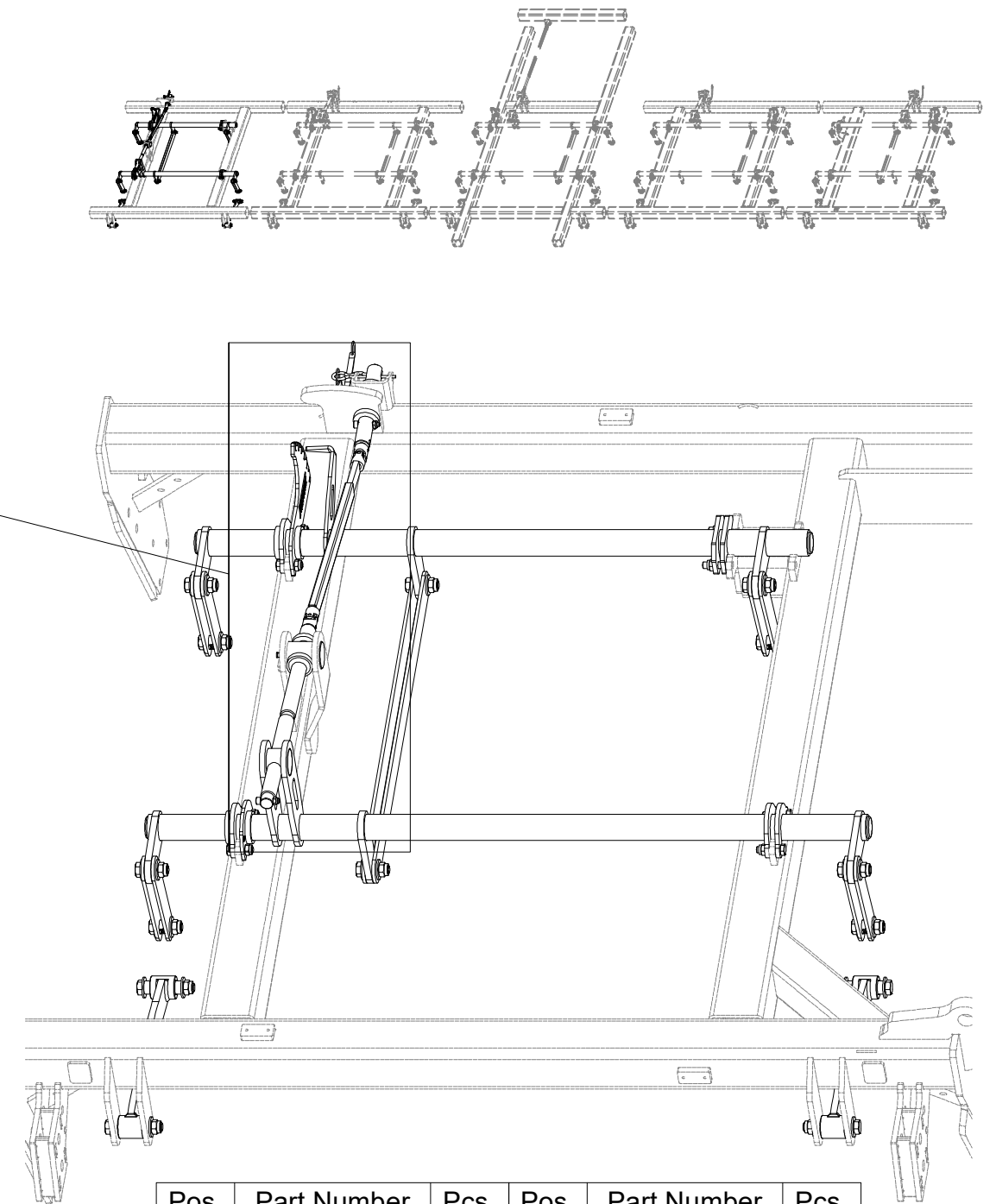
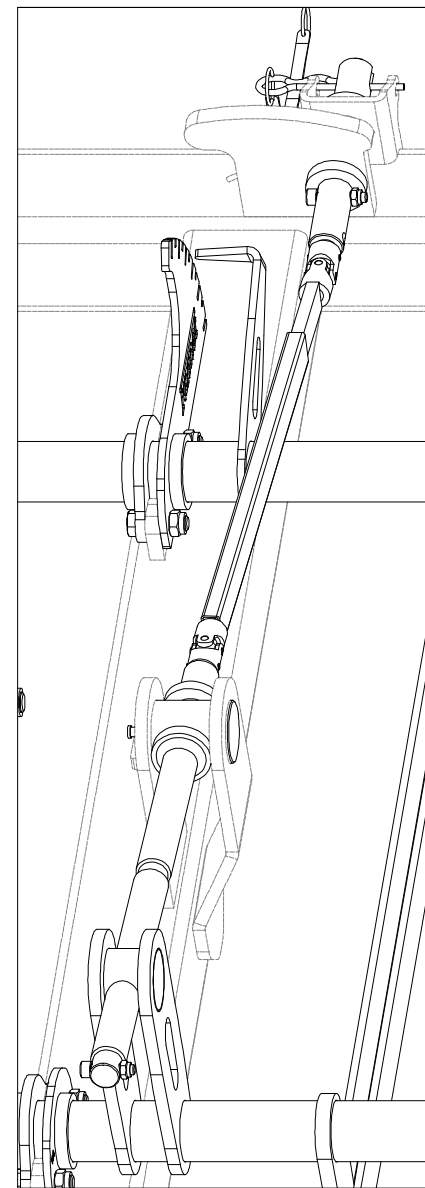
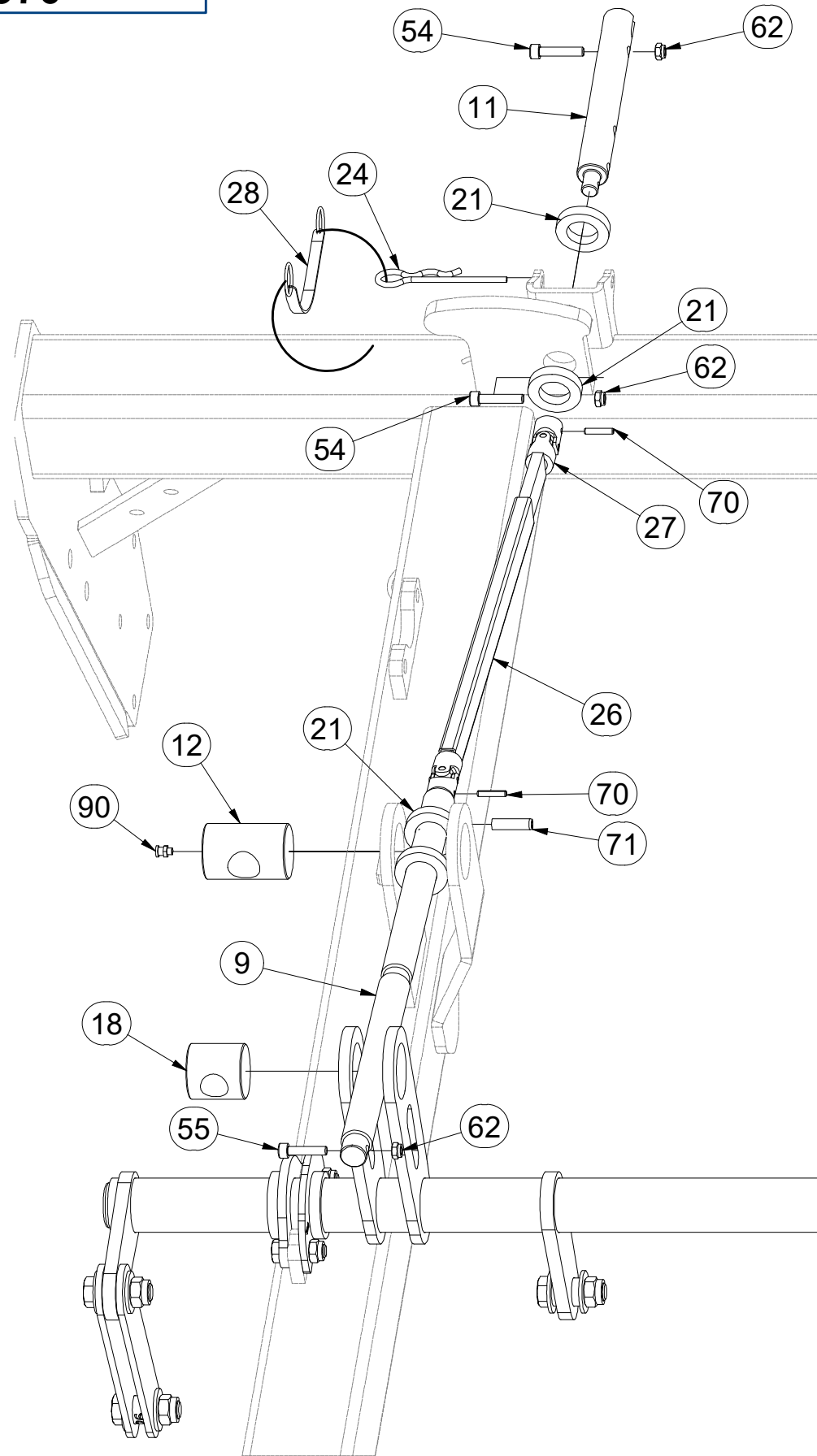

Pos.	Part Number	Pcs.	Pos.	Part Number	Pcs.
9	4024252	2	28	m12467	4
11	4023084	2	54	m13894	4
12	9002114	5	55	m09464	5
18	4005340	5	62	m04503	9
21	9002560	9	70	m12284	4
24	m09988	4	71	m10736	5
26	9005322	1	90	m10451	5
27	9005323	1			

Ⓒ SADA OVLÁDÁNÍ RADLIC

Ⓓ STEUERSATZ PFLUGSCHAREN

Ⓕ KIT DE COMMANDE DES SOCS

Ⓖ SET OF PLOUGHSHARE CONTROL

Ⓡ КОМПЛЕКТ УПРАВЛЕНИЯ ЛАП

Ⓟ ZESTAW STEROWANIA RADLICAMI



**3011970**

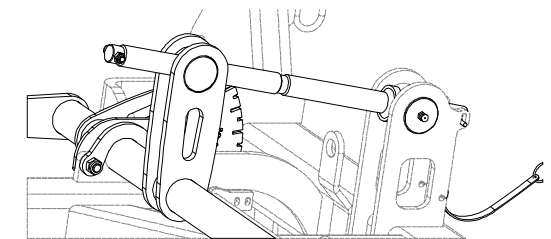
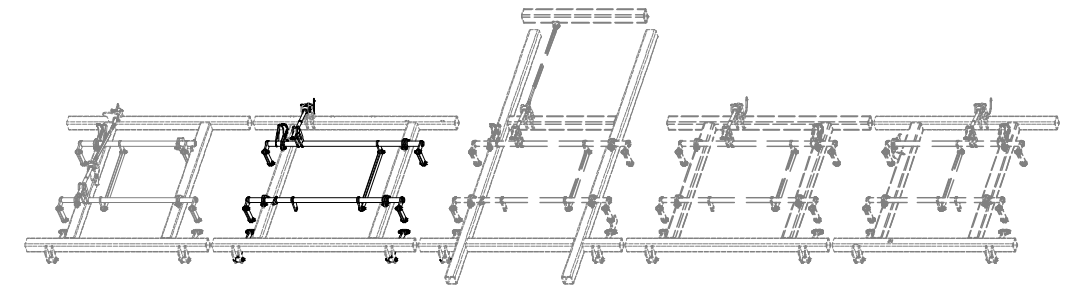
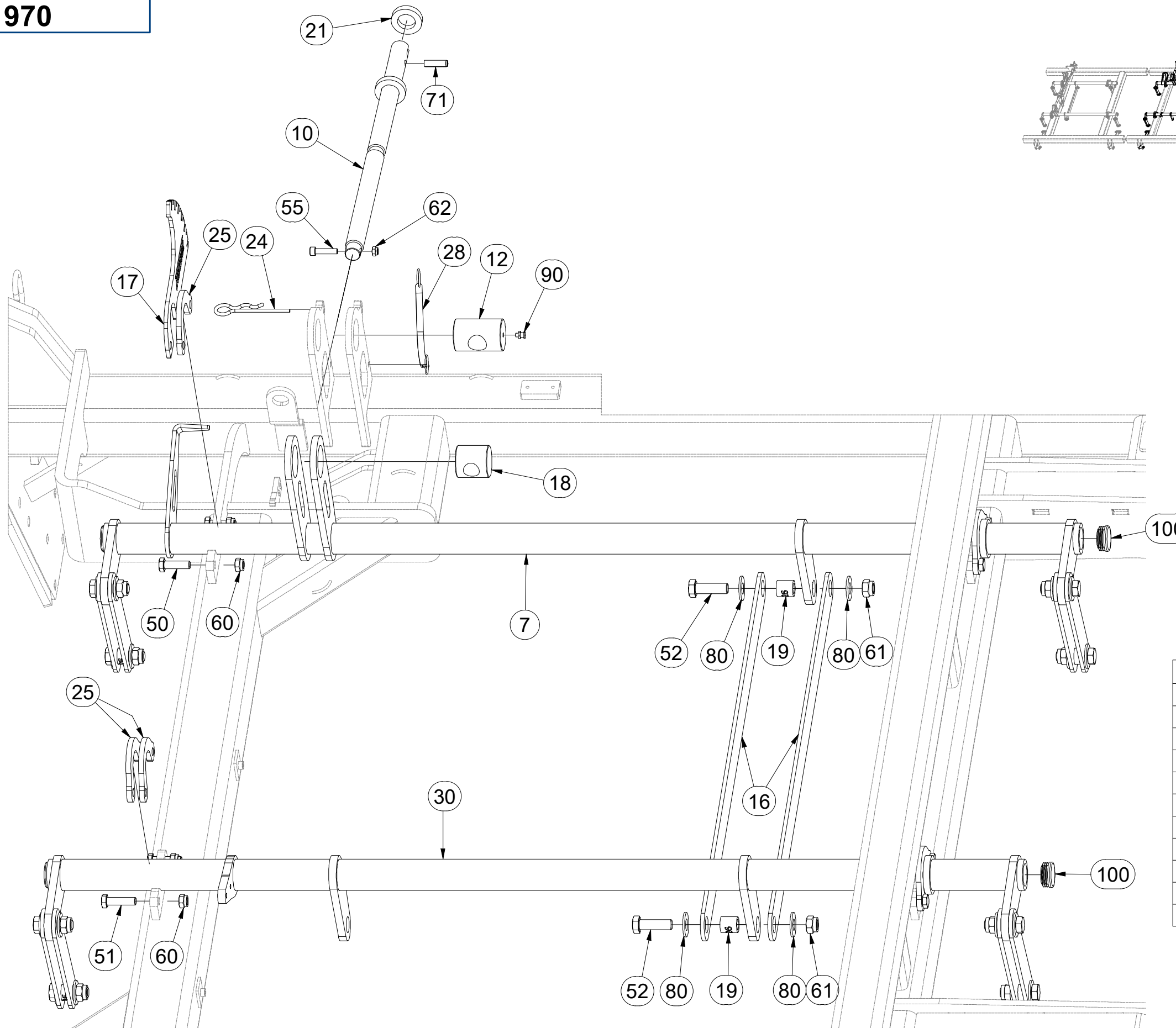

Pos.	Part Number	Pcs.	Pos.	Part Number	Pcs.
7	3002884	1	30	VZ00018119	1
10	4024250	3	50	m03926	14
12	9002114	5	51	m06077	26
16	4005334	10	52	m04355	50
17	4023896	5	55	m09464	5
18	4005340	5	60	m04301	40
19	4002265	50	61	m03683	70
21	9002560	9	62	m04503	9
24	m09988	4	71	m10736	5
25	4005332	32	80	m05651	140
28	m12467	4	90	m10451	5
			100	m10130	20

Ⓒ SADA OVLÁDÁNÍ RADLIC

Ⓓ STEUERSATZ PFLUGSCHAREN

Ⓕ KIT DE COMMANDE DES SOCS

Ⓖ SET OF PLOUGHSHARE CONTROL

Ⓡ КОМПЛЕКТ УПРАВЛЕНИЯ ЛАП

Ⓟ ZESTAW STEROWANIA RADLICAMI



**3011970**

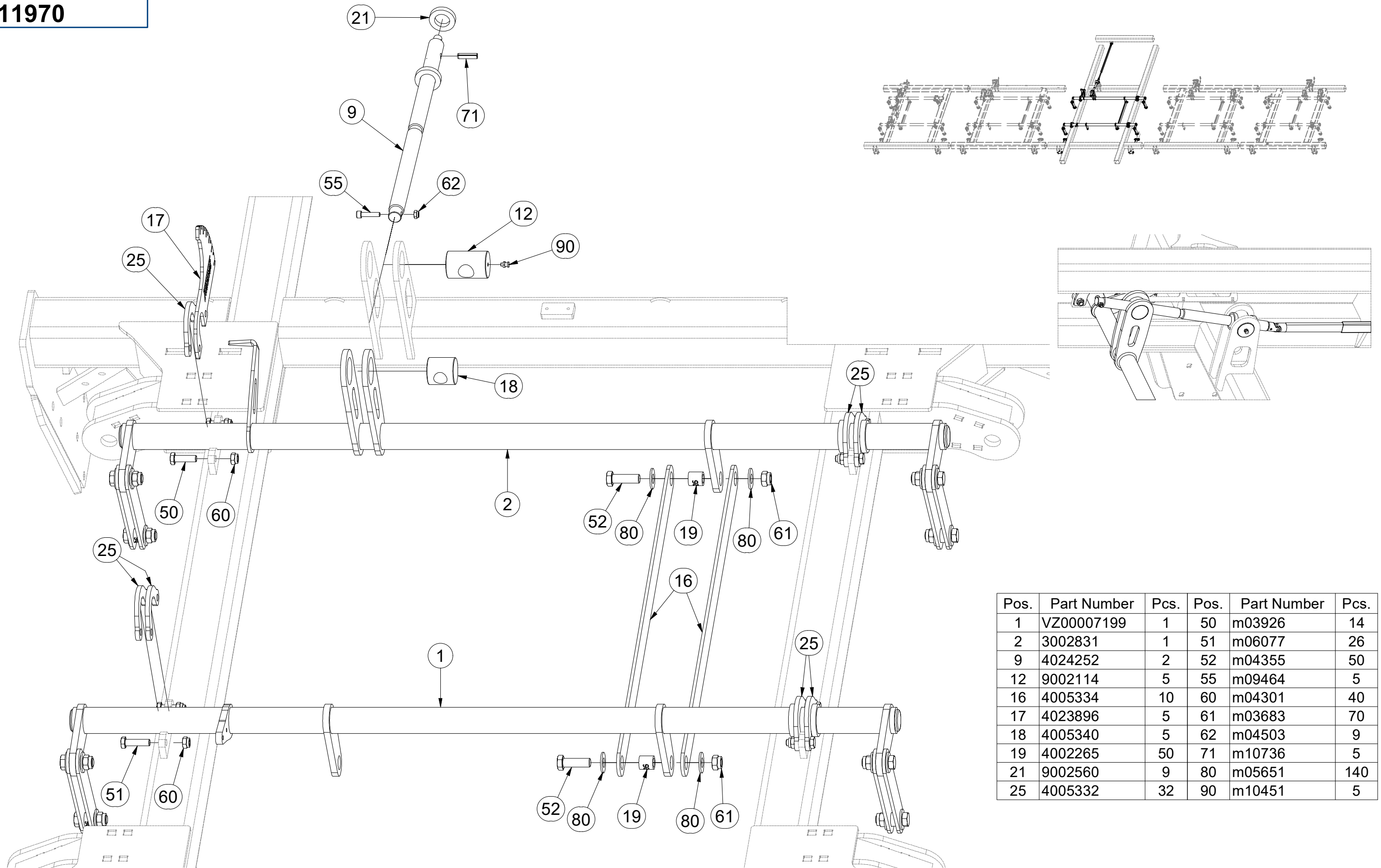

Pos.	Part Number	Pcs.	Pos.	Part Number	Pcs.
1	VZ00007199	1	50	m03926	14
2	3002831	1	51	m06077	26
9	4024252	2	52	m04355	50
12	9002114	5	55	m09464	5
16	4005334	10	60	m04301	40
17	4023896	5	61	m03683	70
18	4005340	5	62	m04503	9
19	4002265	50	71	m10736	5
21	9002560	9	80	m05651	140
25	4005332	32	90	m10451	5

Ⓒ SADA OVLÁDÁNÍ RADLIC

Ⓓ STEUERSATZ PFLUGSCHAREN

Ⓕ KIT DE COMMANDE DES SOCS

**3011970**

Ⓖ SET OF PLOUGHSHARE CONTROL

Ⓔ КОМПЛЕКТ УПРАВЛЕНИЯ ЛАП

Ⓗ ZESTAW STEROWANIA RADLICAMI

**Farmet**

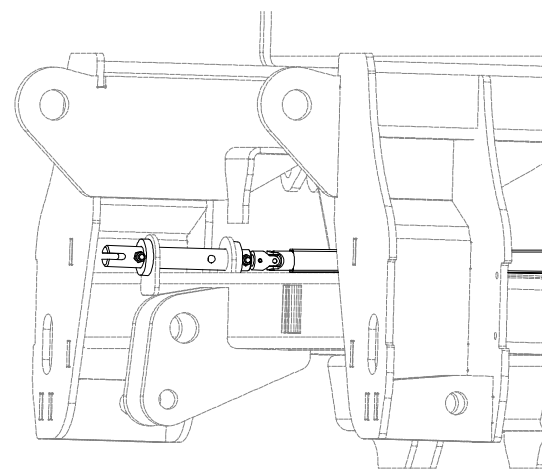
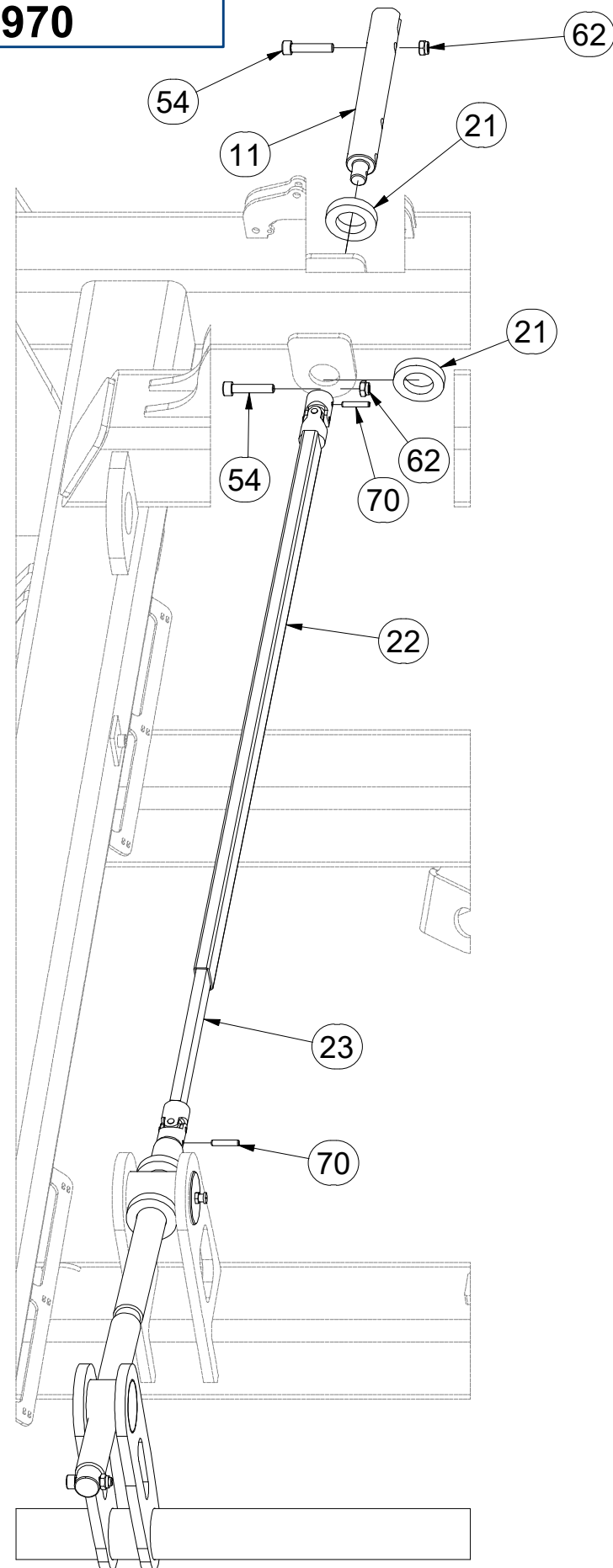

Pos.	Part Number	Pcs.
11	4023084	2
21	9002560	9
22	9003620	1
23	m05173	1
54	m13894	4
62	m04503	9
70	m12284	4

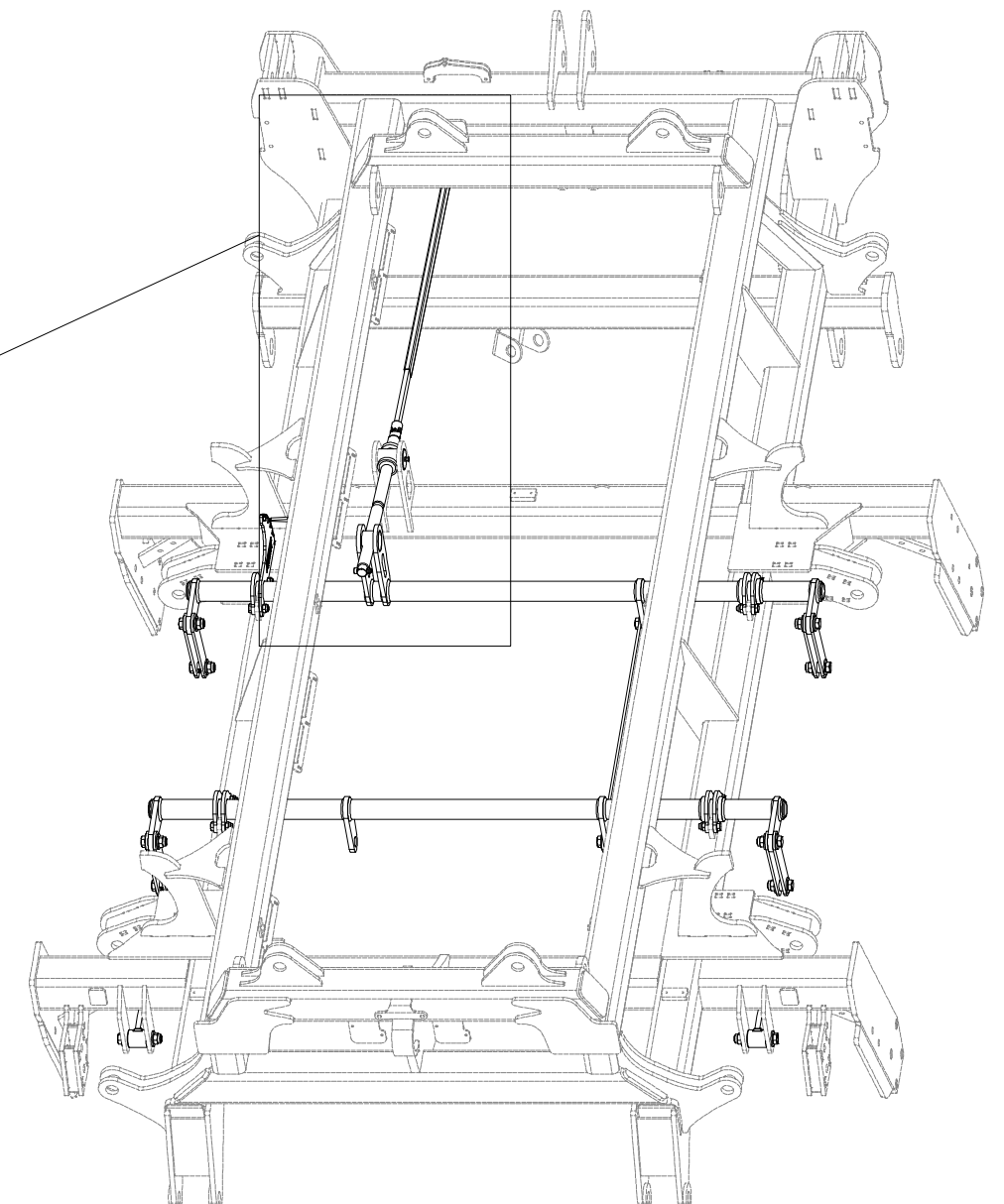
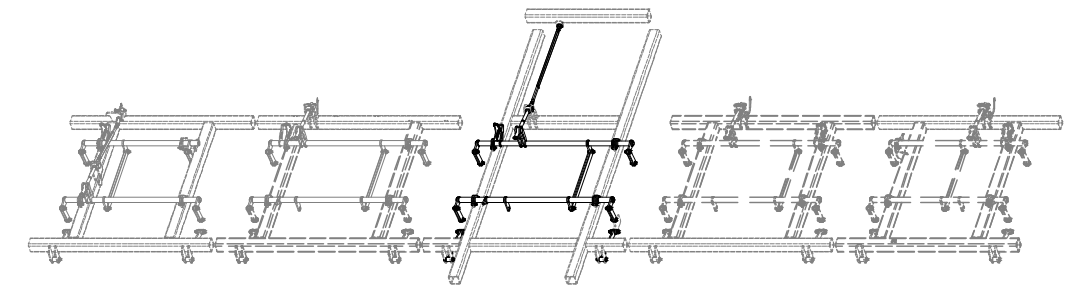
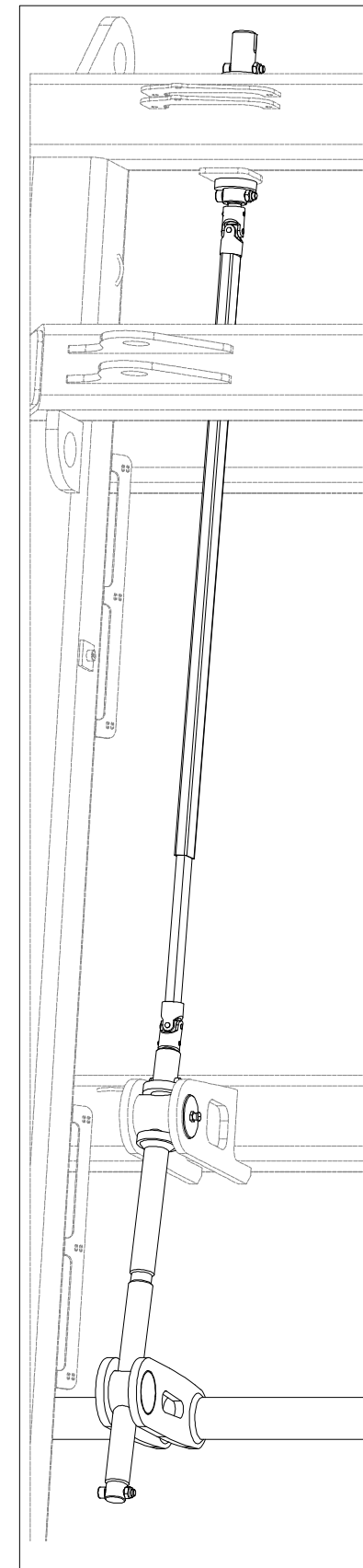

Ⓒ SADA OVLÁDÁNÍ RADLIC

Ⓓ STEUERSATZ PFLUGSCHAREN

Ⓕ KIT DE COMMANDE DES SOCS

Ⓖ SET OF PLOUGHSHARE CONTROL

Ⓡ КОМПЛЕКТ УПРАВЛЕНИЯ ЛАП

Ⓟ ZESTAW STEROWANIA RADLICAMI



**3011970**

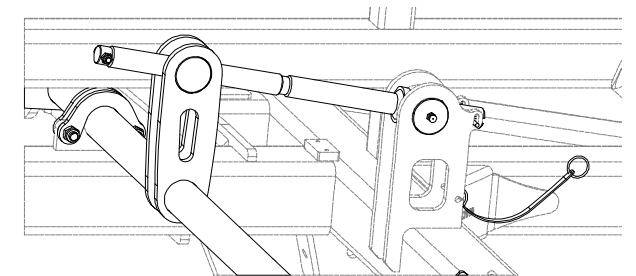
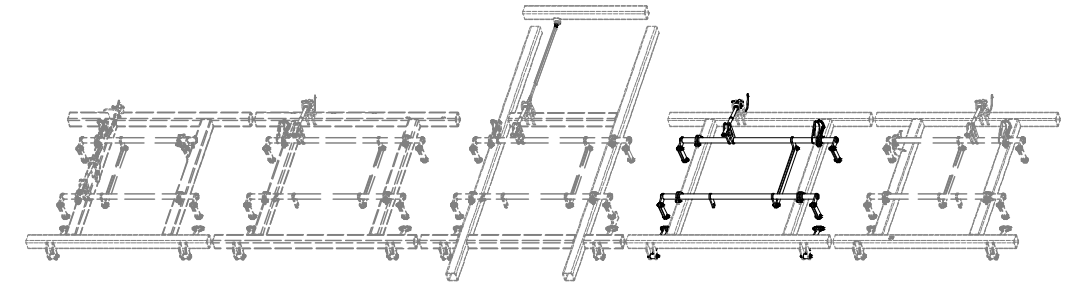
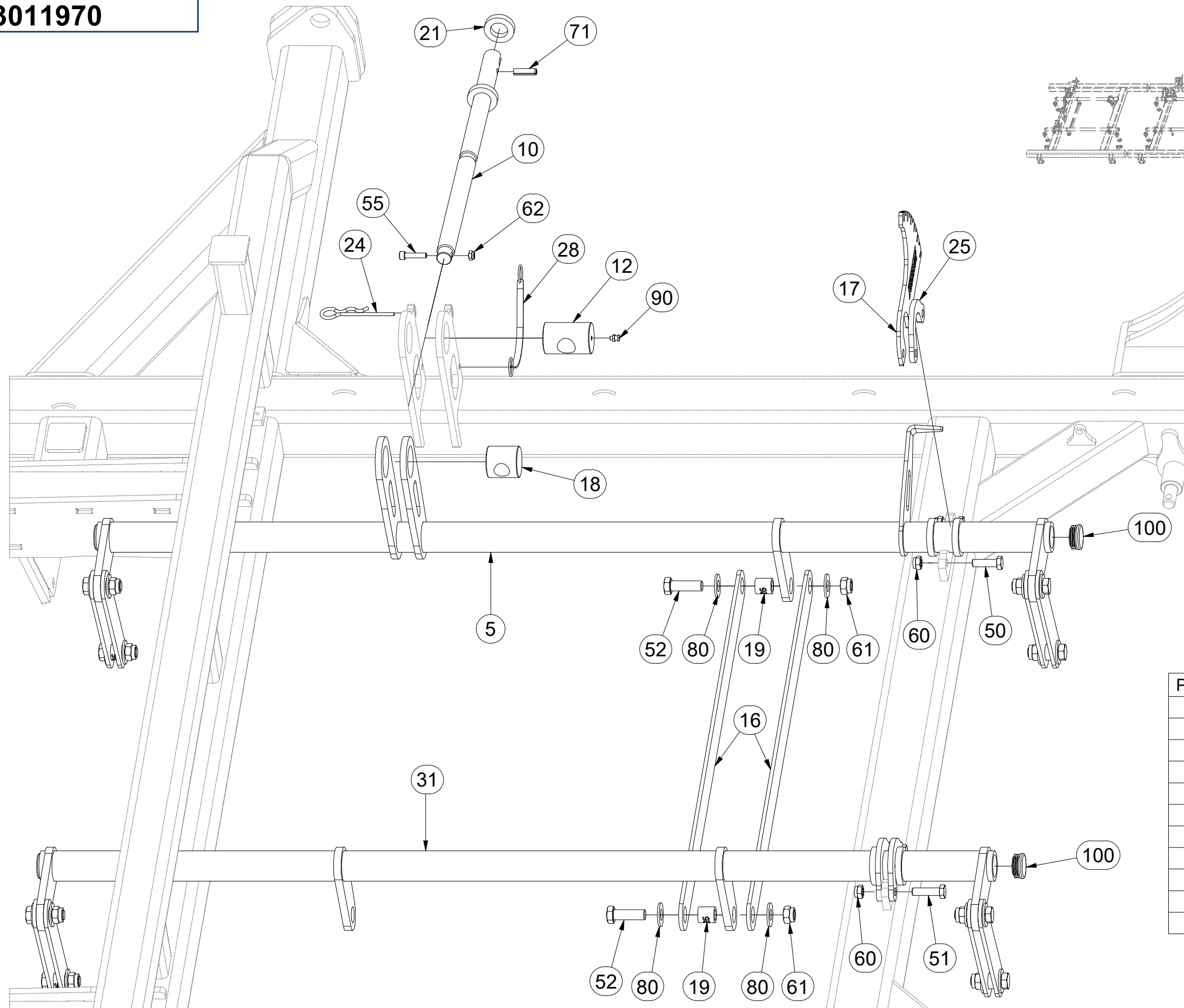

Pos.	Part Number	Pcs.	Pos.	Part Number	Pcs.
5	3002883	1	31	VZ00018120	1
10	4024250	3	50	m03926	14
12	9002114	5	51	m06077	26
16	4005334	10	52	m04355	50
17	4023896	5	55	m09464	5
18	4005340	5	60	m04301	40
19	4002265	50	61	m03683	70
21	9002560	9	62	m04503	9
24	m09988	4	71	m10736	5
25	4005332	32	80	m05651	140
28	m12467	4	90	m10451	5
			100	m10130	20

Ⓒ SADA OVLÁDÁNÍ RADLIC

Ⓓ STEUERSATZ PFLUGSCHAREN

Ⓕ KIT DE COMMANDE DES SOCS

Ⓖ SET OF PLOUGHSHARE CONTROL

Ⓔ КОМПЛЕКТ УПРАВЛЕНИЯ ЛАП

Ⓗ ZESTAW STEROWANIA RADLICAMI



**3011970**

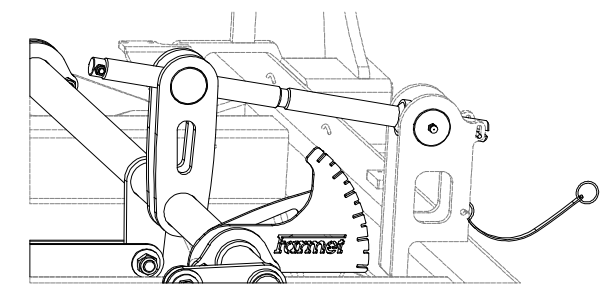
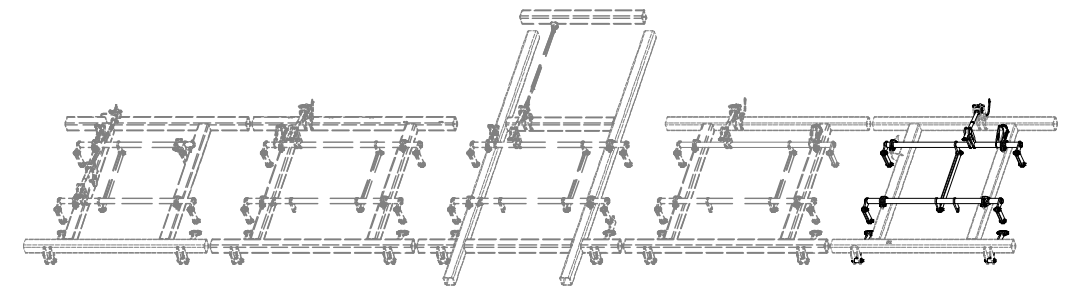
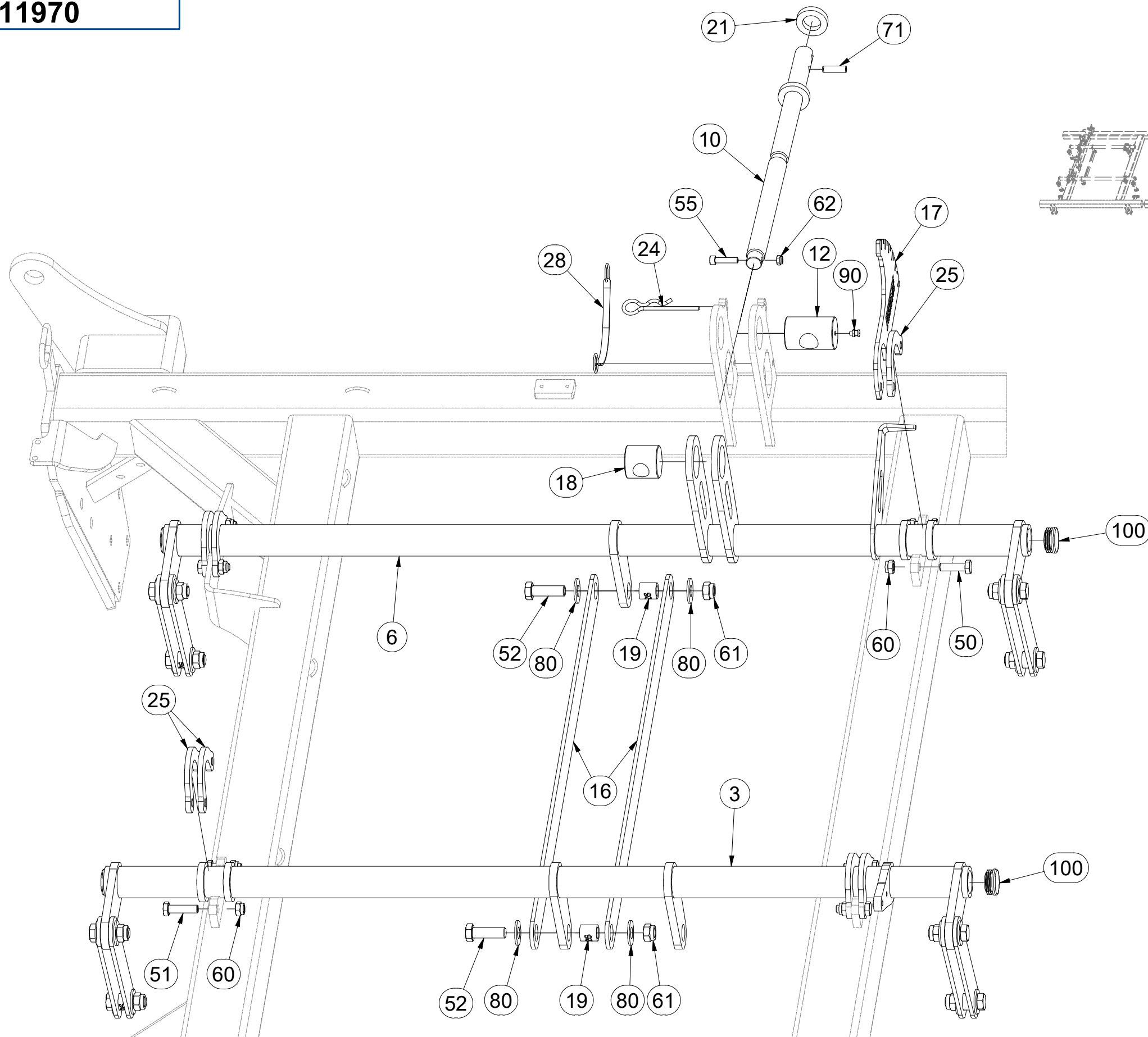

Pos.	Part Number	Pcs.	Pos.	Part Number	Pcs.
3	VZ00018082	1	50	m03926	14
6	3005287	1	51	m06077	26
10	4024250	3	52	m04355	50
12	9002114	5	55	m09464	5
16	4005334	10	60	m04301	40
17	4023896	5	61	m03683	70
18	4005340	5	62	m04503	9
19	4002265	50	71	m10736	5
21	9002560	9	80	m05651	140
24	m09988	4	90	m10451	5
25	4005332	32	100	m10130	20
28	m12467	4			



Ⓒ SADA RADLIC

Ⓓ SCHARSATZ

Ⓕ KIT DE SOCS

Ⓖ SET OF PLOUGHSHARES

Ⓡ КОМПЛЕКТ ЛАП

Ⓟ ZESTAW REDLIC



**3012377**

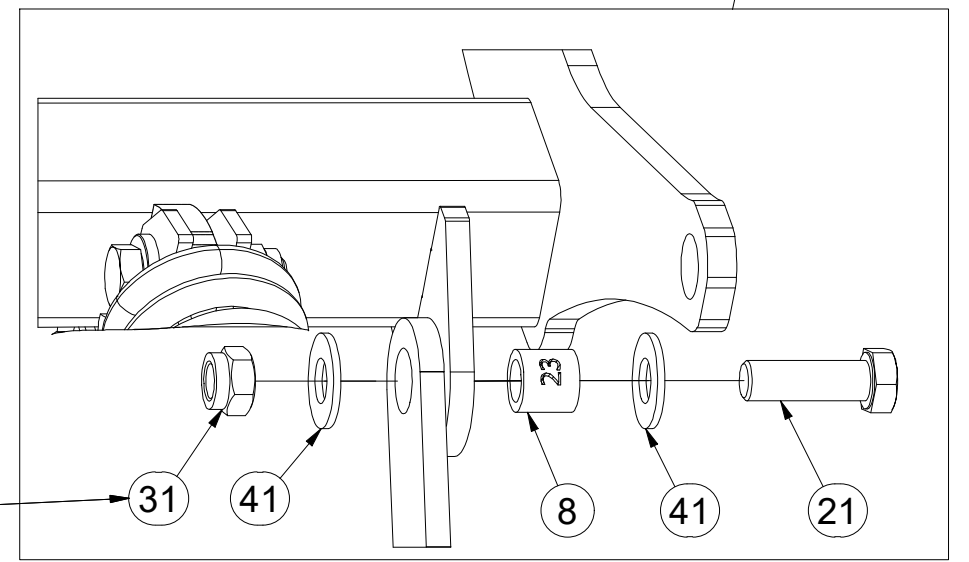
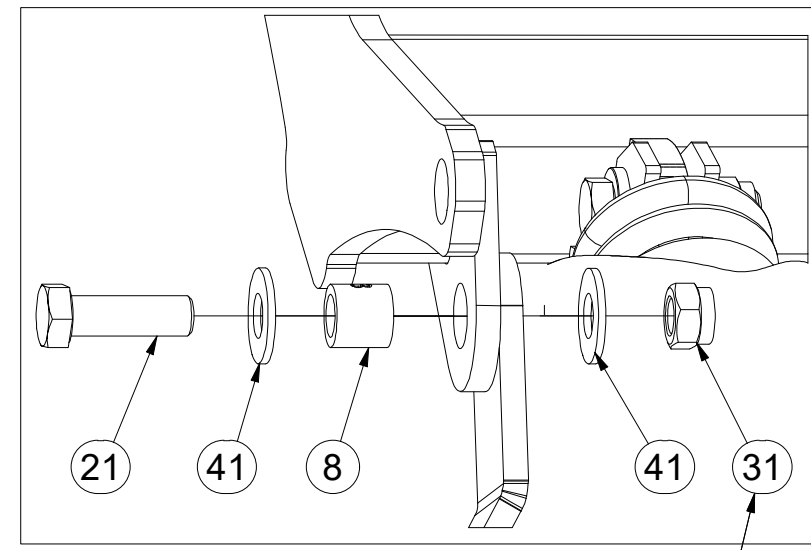
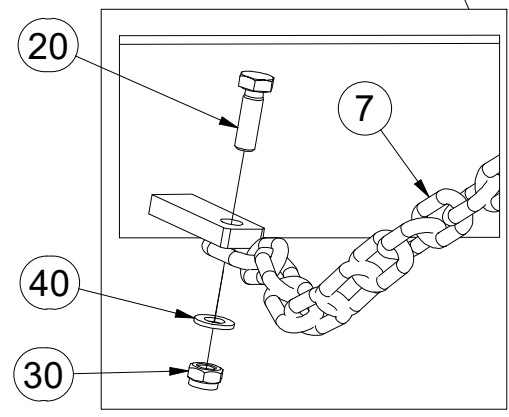
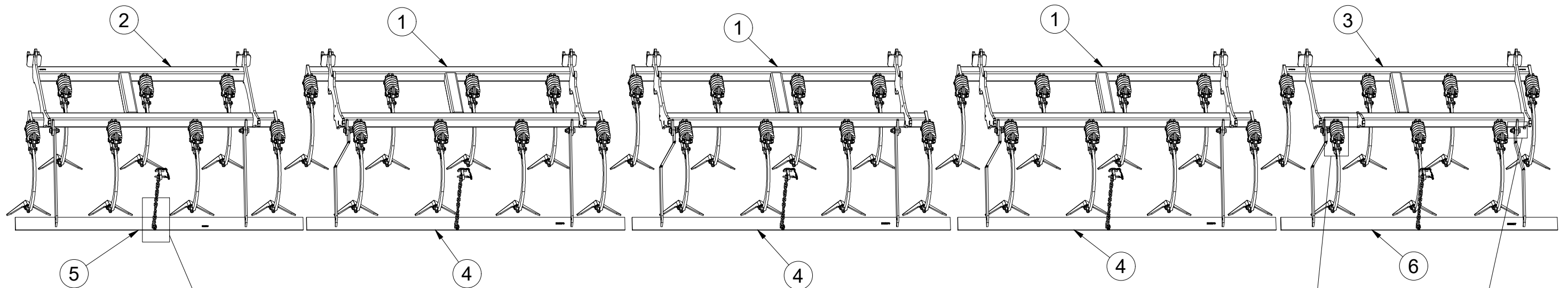

60Nm

Pos.	Part Number	Pcs.	Pos.	Part Number	Pcs.
1	VZ00015183	3	8	4022223	10
2	3012484	1	20	m01092	5
3	3012485	1	21	m04355	10
4	3009576	3	30	m04503	5
5	3005376	1	31	m03683	10
6	3009577	1	40	m01203	5
7	4001641	5	41	m05651	20

ⒸZ SADA RADLIC

Ⓓ SCHARSATZ

Ⓕ KIT DE SOCS

ⒼB SET OF PLOUGHSHARES

ⒺU КОМПЛЕКТ ЛАП

ⒽL ZESTAW REDLIC



**3012484**

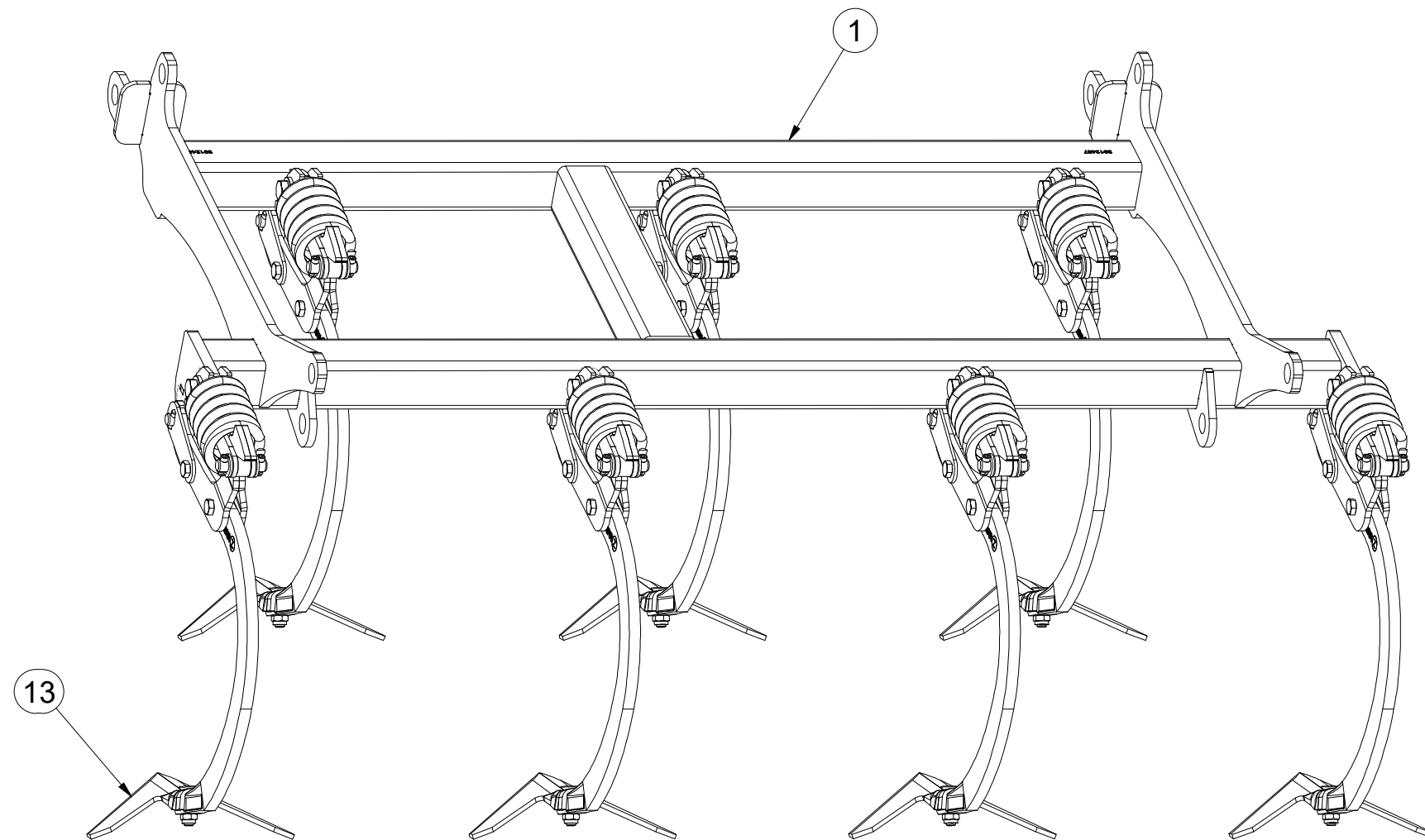
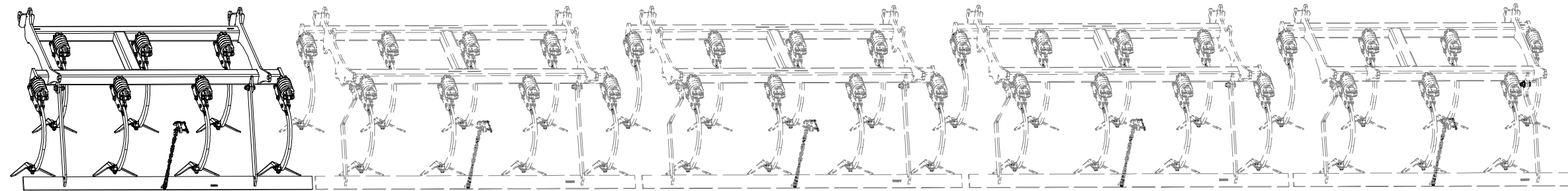

Pos.	Part Number	Pcs.
1	3012487	1
13	3000236-KOO	7

ⒸZ SADA RADLIC

Ⓓ SCHARSATZ

Ⓕ KIT DE SOCS

ⒼB SET OF PLOUGHSHARES

ⒺU КОМПЛЕКТ ЛАП

ⒻL ZESTAW REDLIC



**3012484**

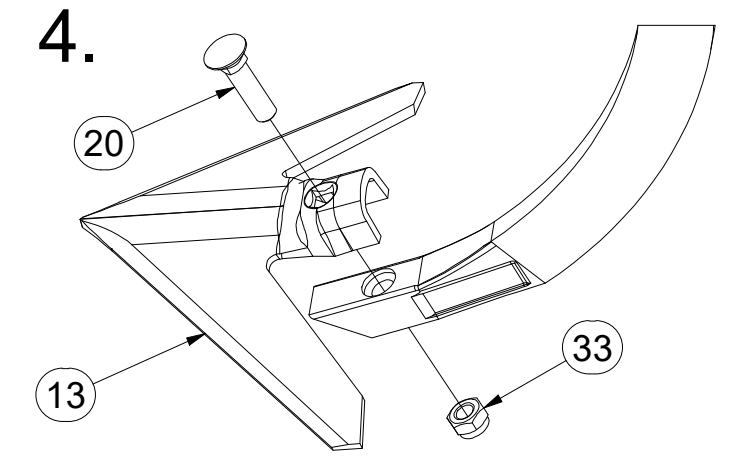
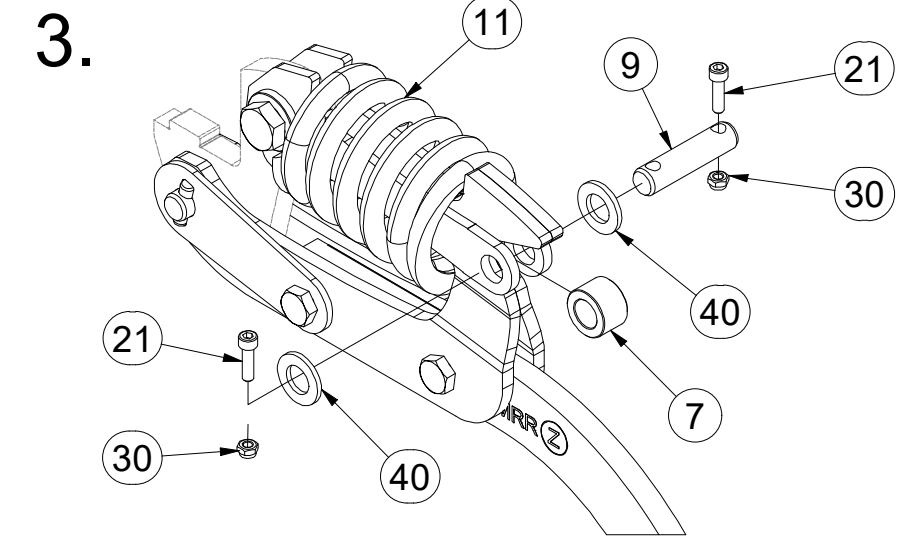
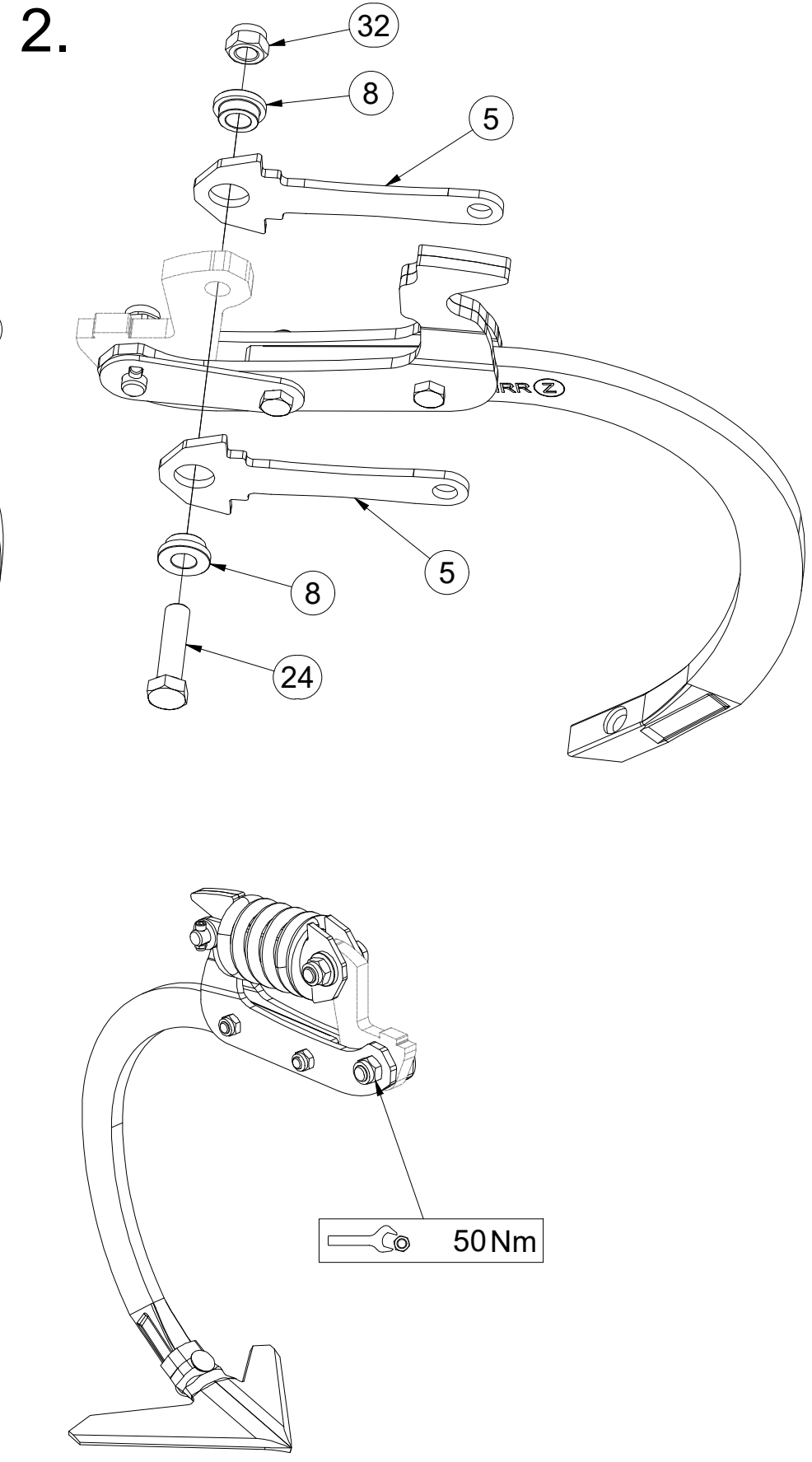
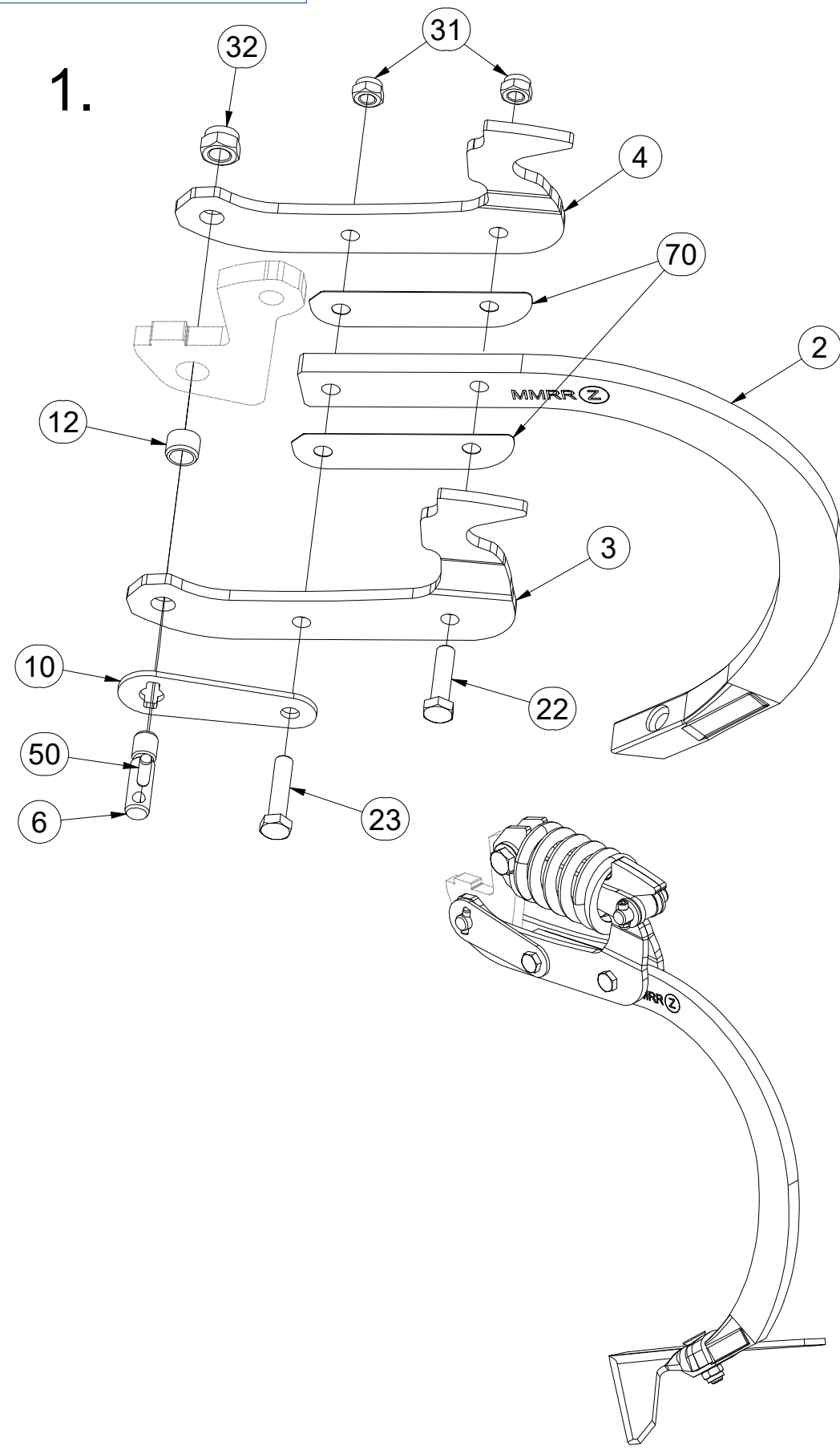

Pos.	Part Number	Pcs.	Pos.	Part Number	Pcs.
2	9005683	7	20	m10440	7
3	3012358	7	21	m15215	14
4	3012359	7	22	m06077	7
5	4024906	14	23	m03339	7
6	4024918	7	24	m14482	7
7	4009624	7	30	m05560	14
8	4014252	14	31	m04301	14
9	4015783	7	32	m03683	14
10	VZ00003688	7	33	m21001	7
11	m18880	7	40	m14971	14
12	m18882	7	50	m18826	7
13	3000236-KOO	7	70	4014863	14

ⒸZ SADA RADLIC

Ⓓ SCHARSATZ

Ⓕ KIT DE SOCS

ⒼB SET OF PLOUGHSHARES

ⒺU КОМПЛЕКТ ЛАП

ⒽL ZESTAW REDLIC



**VZ00015183**

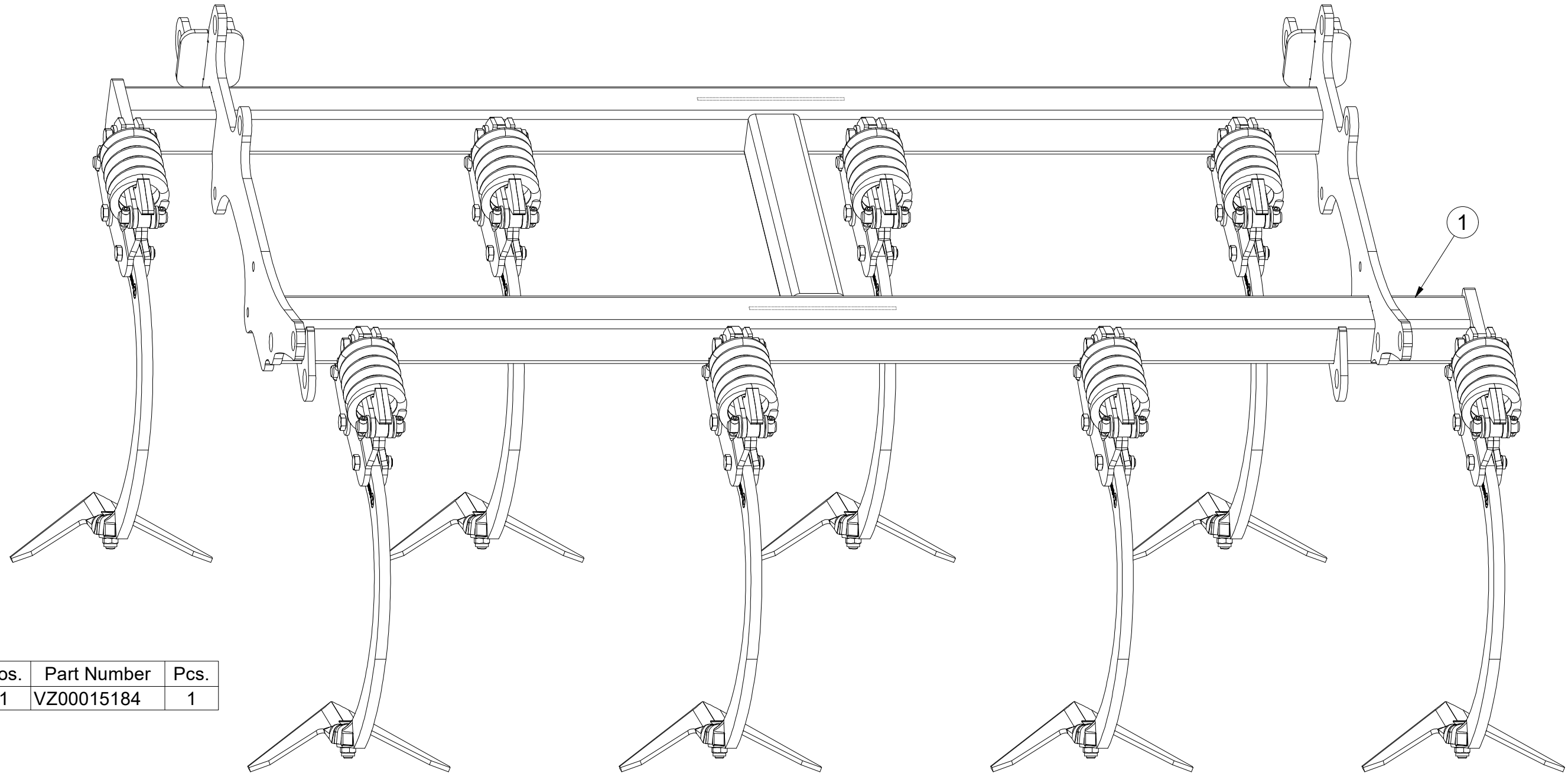
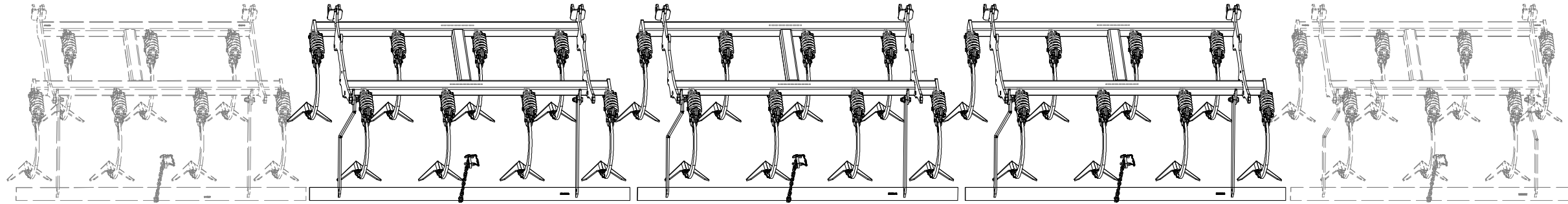

Pos.	Part Number	Pcs.
1	VZ00015184	1

Ⓒ SADA RADLIC

Ⓓ SCHARSATZ

Ⓕ KIT DE SOCS

**VZ00015183**

Ⓖ SET OF PLOUGHSHARES

Ⓡ КОМПЛЕКТ ЛАП

Ⓢ ZESTAW REDLIC

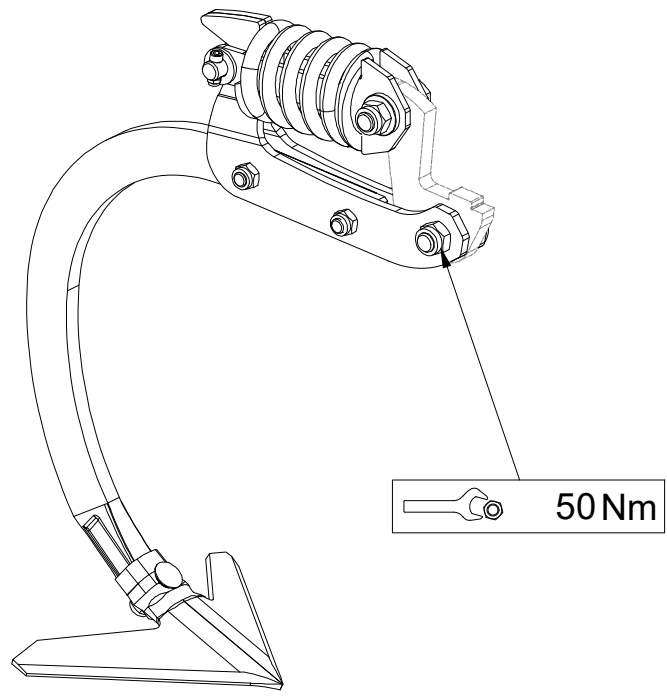
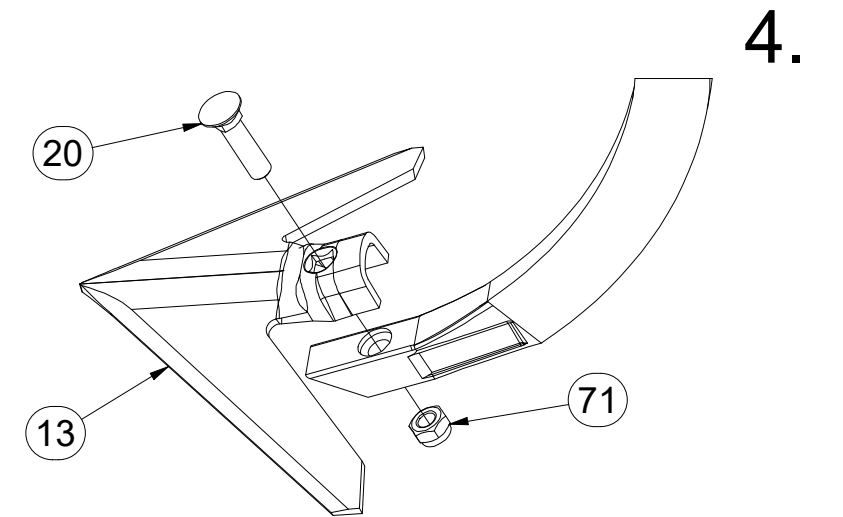
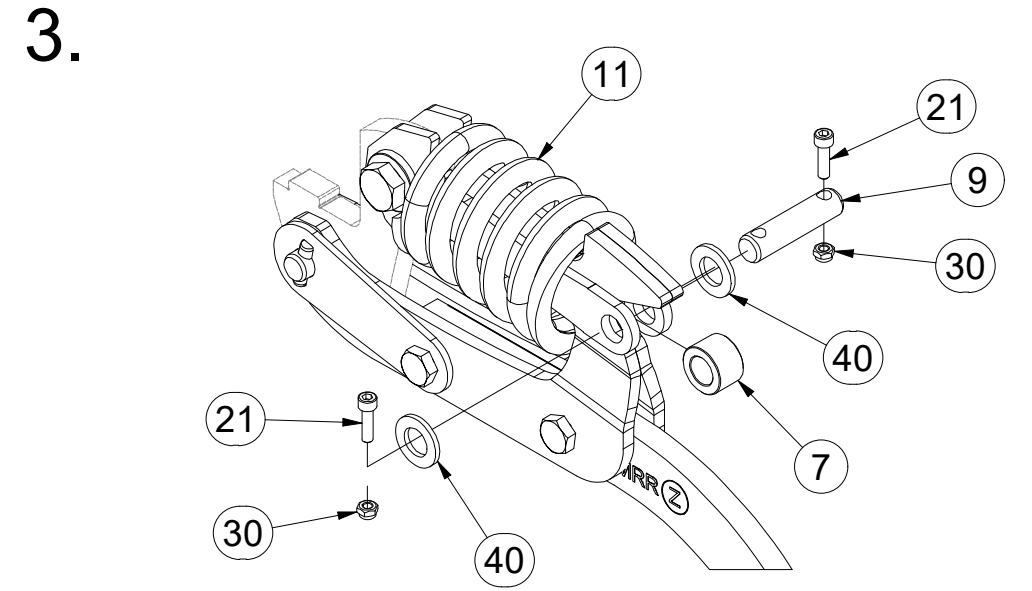
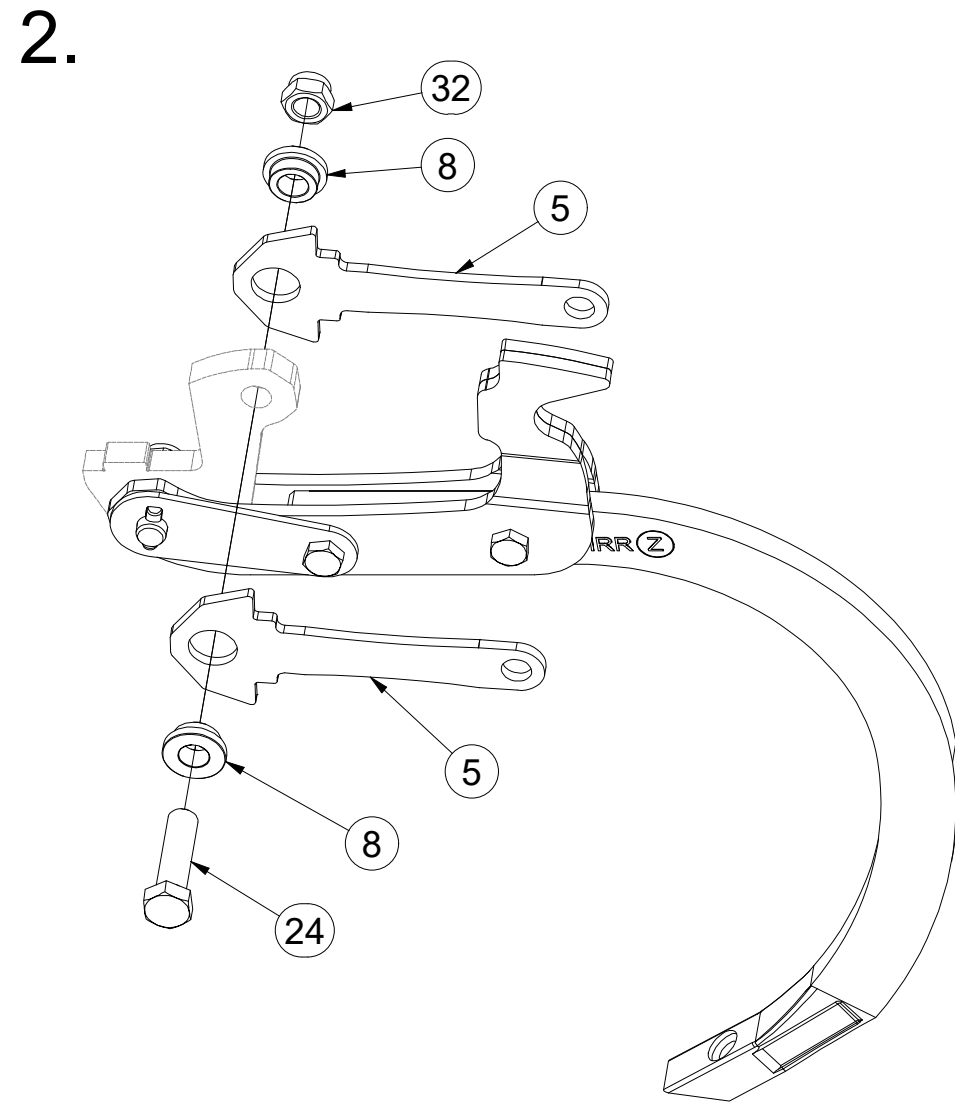
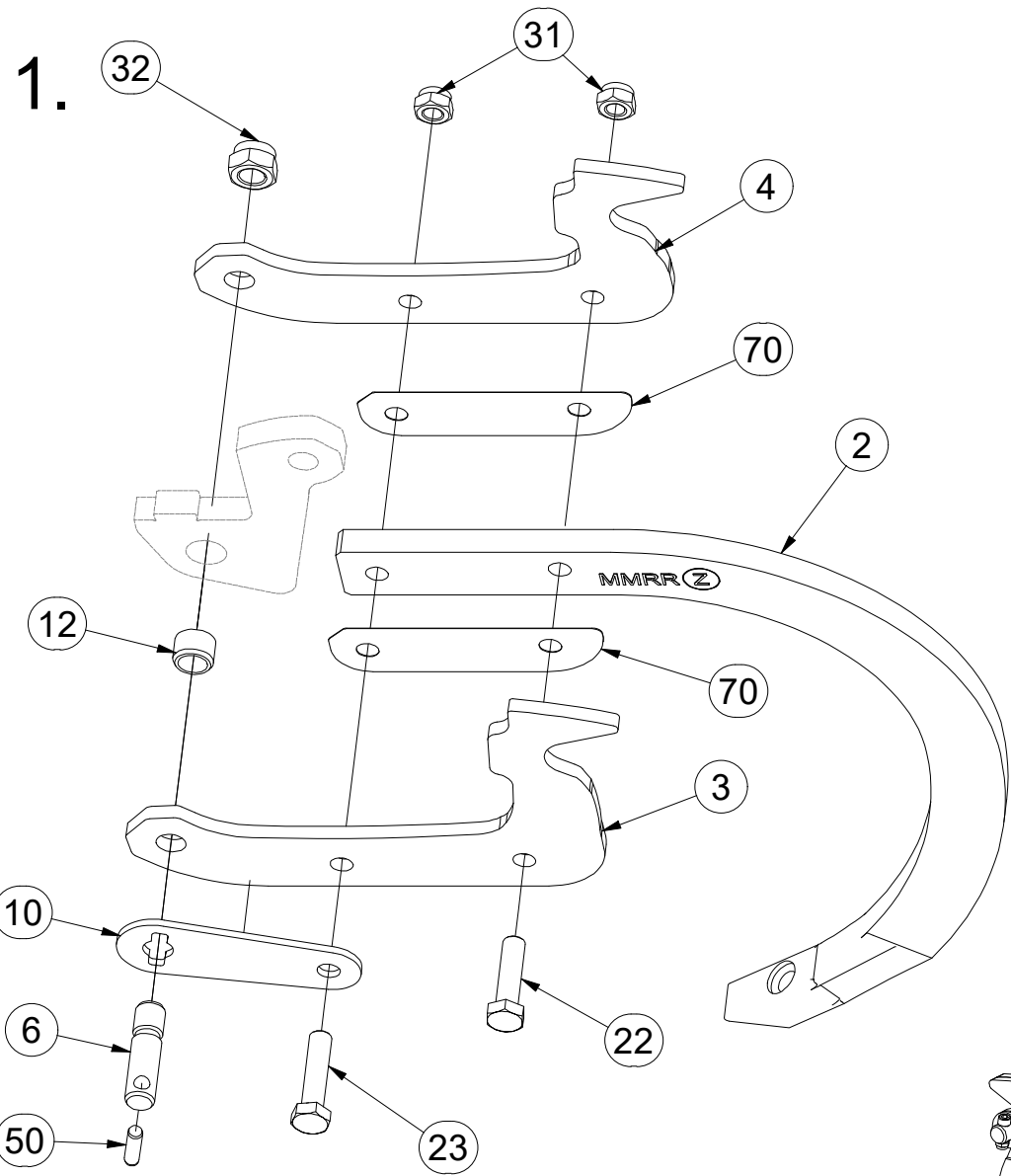

Pos.	Part Number	Pcs.	Pos.	Part Number	Pcs.
2	9005683	8	20	m10440	8
3	3012358	8	21	m15215	16
4	3012359	8	22	m06077	8
5	4024906	16	23	m03339	8
6	4024918	8	24	m14482	8
7	4009624	8	30	m05560	16
8	4014252	16	31	m04301	16
9	4015783	8	32	m03683	16
10	VZ00003688	8	40	m14971	16
11	m18880	8	50	m18826	8
12	m18882	8	70	4014863	16
13	3000236-KOO	8	71	m21001	8

Ⓒ SADA RADLIC

Ⓓ SCHARSATZ

Ⓕ KIT DE SOCS

**3012485**

Ⓖ SET OF PLOUGHSHARES

Ⓡ КОМПЛЕКТ ЛАП

Ⓟ ZESTAW REDLIC

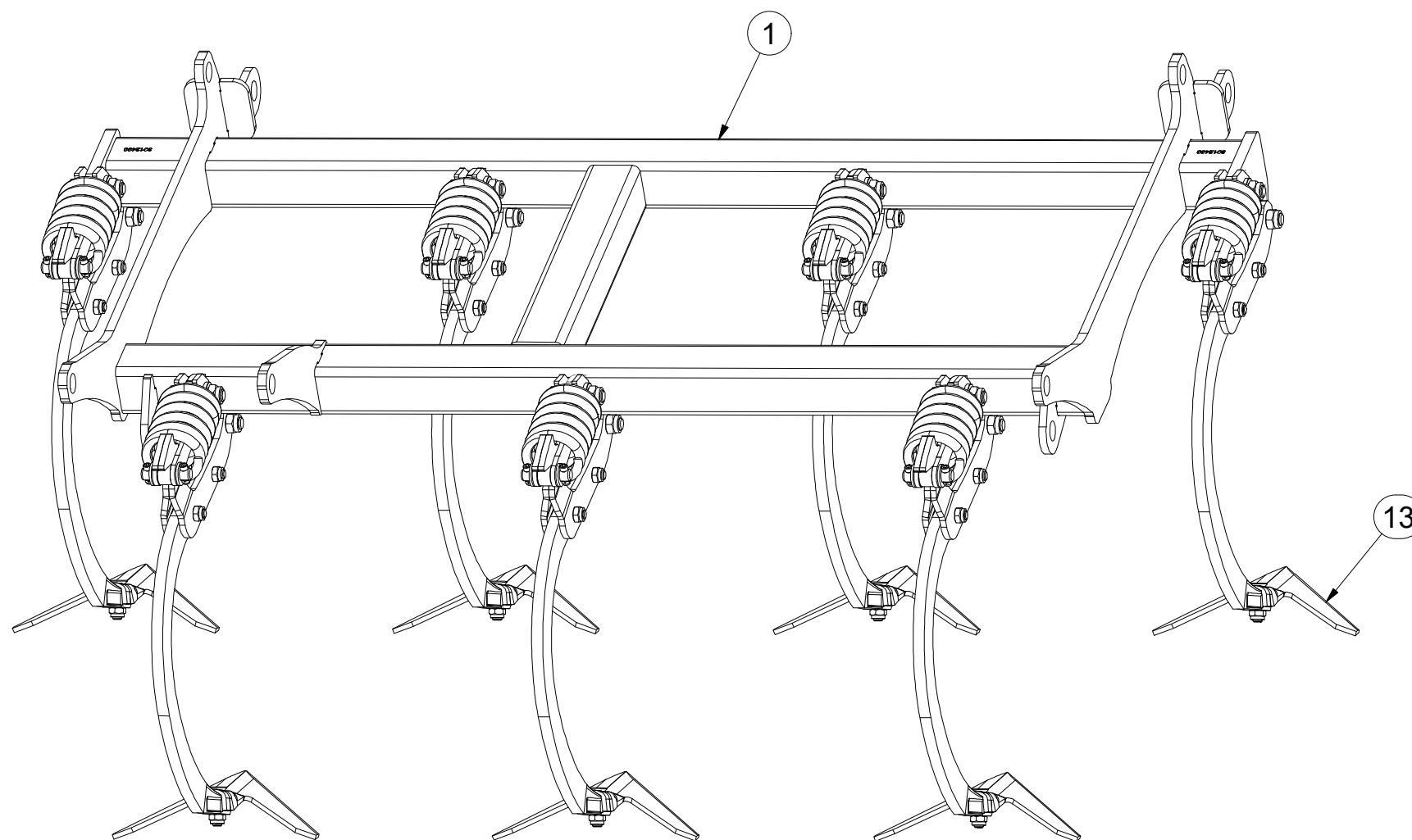
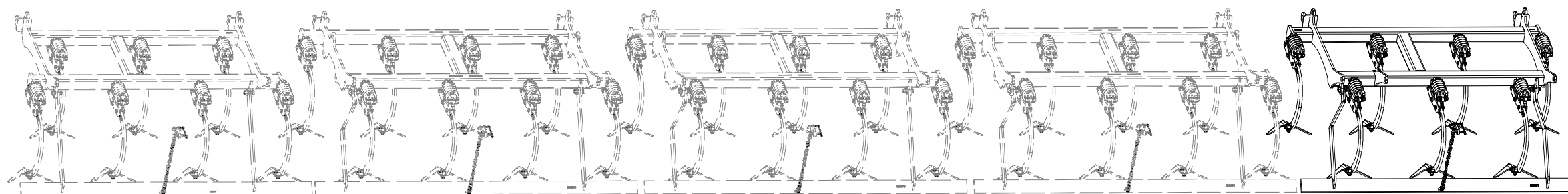

Pos.	Part Number	Pcs.
1	3012488	1
13	3000236-KOO	7

Ⓒ SADA RADLIC

Ⓓ SCHARSATZ

Ⓕ KIT DE SOCS

Ⓖ SET OF PLOUGHSHARES

Ⓡ КОМПЛЕКТ ЛАП

Ⓢ ZESTAW REDLIC



**3012485**

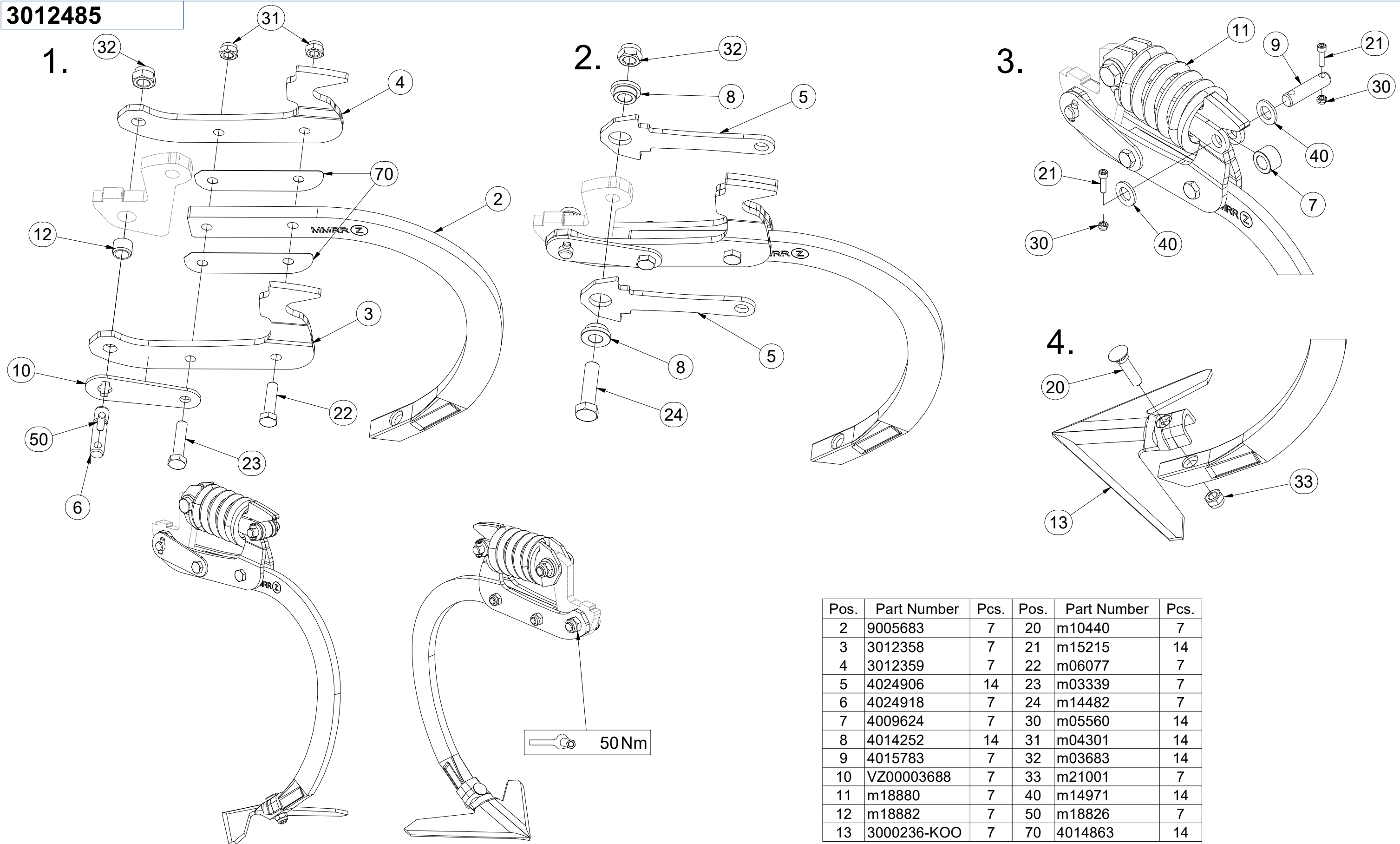

Pos.	Part Number	Pcs.	Pos.	Part Number	Pcs.
2	9005683	7	20	m10440	7
3	3012358	7	21	m15215	14
4	3012359	7	22	m06077	7
5	4024906	14	23	m03339	7
6	4024918	7	24	m14482	7
7	4009624	7	30	m05560	14
8	4014252	14	31	m04301	14
9	4015783	7	32	m03683	14
10	VZ00003688	7	33	m21001	7
11	m18880	7	40	m14971	14
12	m18882	7	50	m18826	7
13	3000236-KOO	7	70	4014863	14

(CZ) SADA ZADNÍCH VÁLČŮ  
 (D) SATZ HINTERE WALZEN  
 (F) KIT DE ROULEAUX ARRIÈRE

(GB) SET OF REAR ROLLERS  
 (RU) КОМПЛЕКТ ЗАДНИХ КАТКОВ  
 (PL) ZESTAW TYLNYCH WAŁÓW



**VZ00019842**

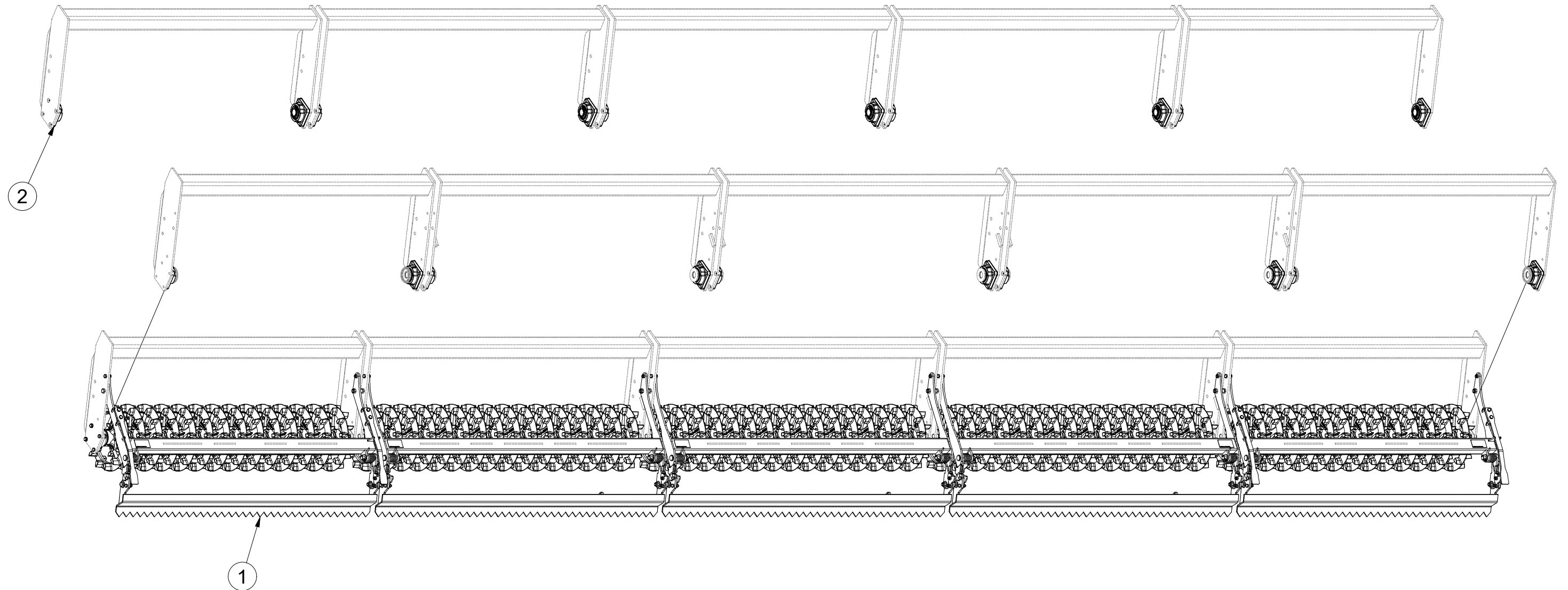

Pos.	Part Number	Pcs.
1	VZ00031011	1
2	VZ00012472	1



- Ⓒ SADA ZADNÍCH VÁLCŮ
- Ⓓ SATZ HINTERE WALZEN
- Ⓕ KIT DE ROULEAUX ARRIÈRE

- Ⓖ SET OF REAR ROLLERS
- Ⓡ КОМПЛЕКТ ЗАДНИХ КАТКОВ
- Ⓟ ZESTAW TYLNYCH WAŁÓW



**VZ00031011**

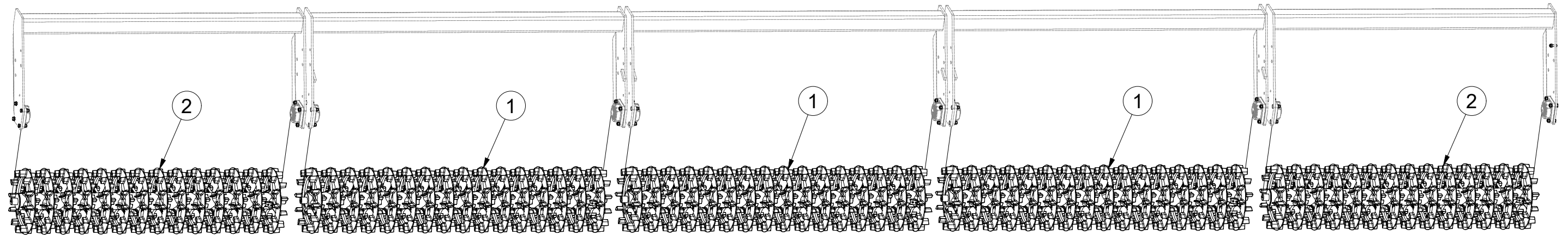
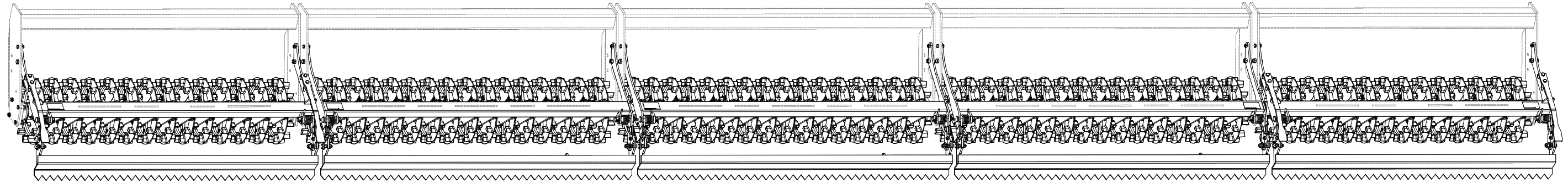

Pos.	Part Number	Pcs.
1	VZ00018566	3
2	VZ00023214	2

CZ SADA ZADNÍCH VÁLČŮ  
 D SATZ HINTERE WALZEN  
 F KIT DE ROULEAUX ARRIÈRE

GB SET OF REAR ROLLERS  
 RU КОМПЛЕКТ ЗАДНИХ КАТКОВ  
 PL ZESTAW TYLNYCH WAŁÓW



**VZ00031011**

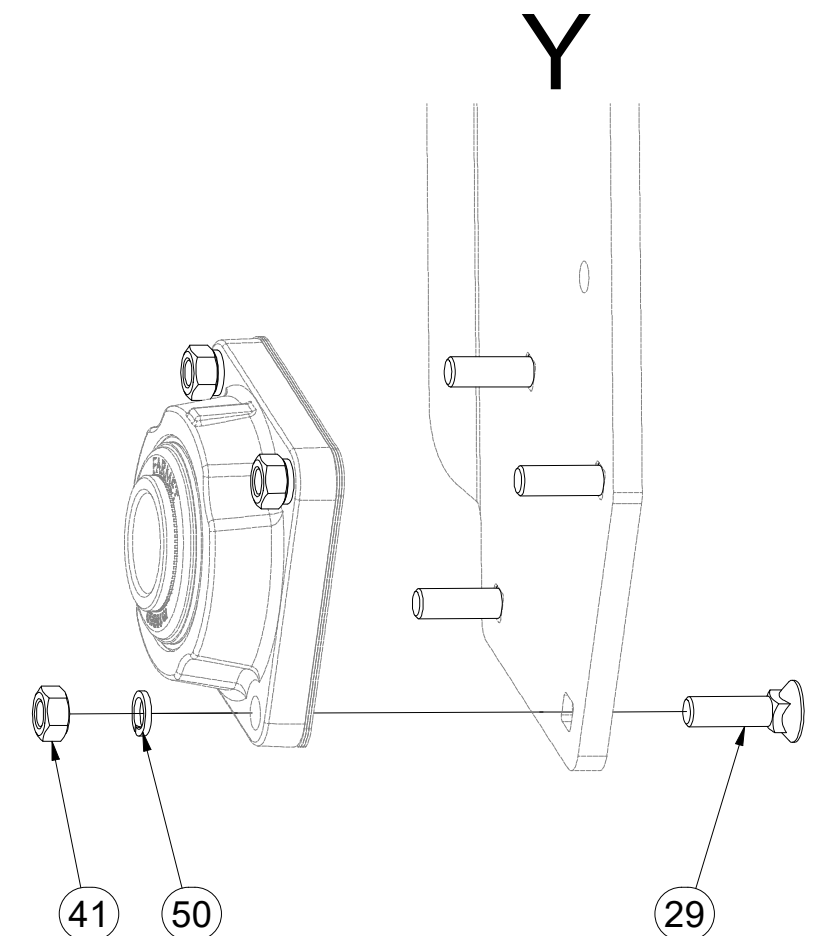
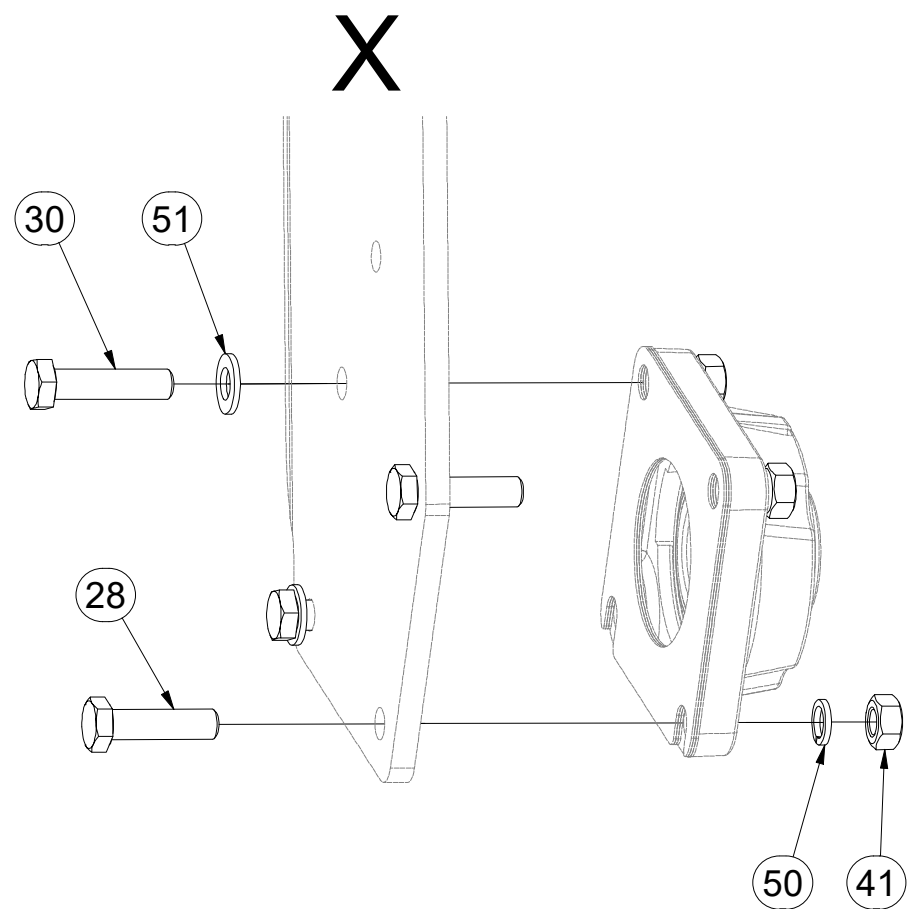

Pos.	Part Number	Pcs.
28	m06077	4
29	m03519	32
30	m03339	4
41	m01305	40
50	m03988	40
51	m17741	4

CZ SADA ZADNÍCH VÁLČŮ  
 D SATZ HINTERE WALZEN  
 F KIT DE ROULEAUX ARRIÈRE

GB SET OF REAR ROLLERS  
 RU КОМПЛЕКТ ЗАДНИХ КАТКОВ  
 PL ZESTAW TYLNYCH WAŁÓW



**VZ00031011**

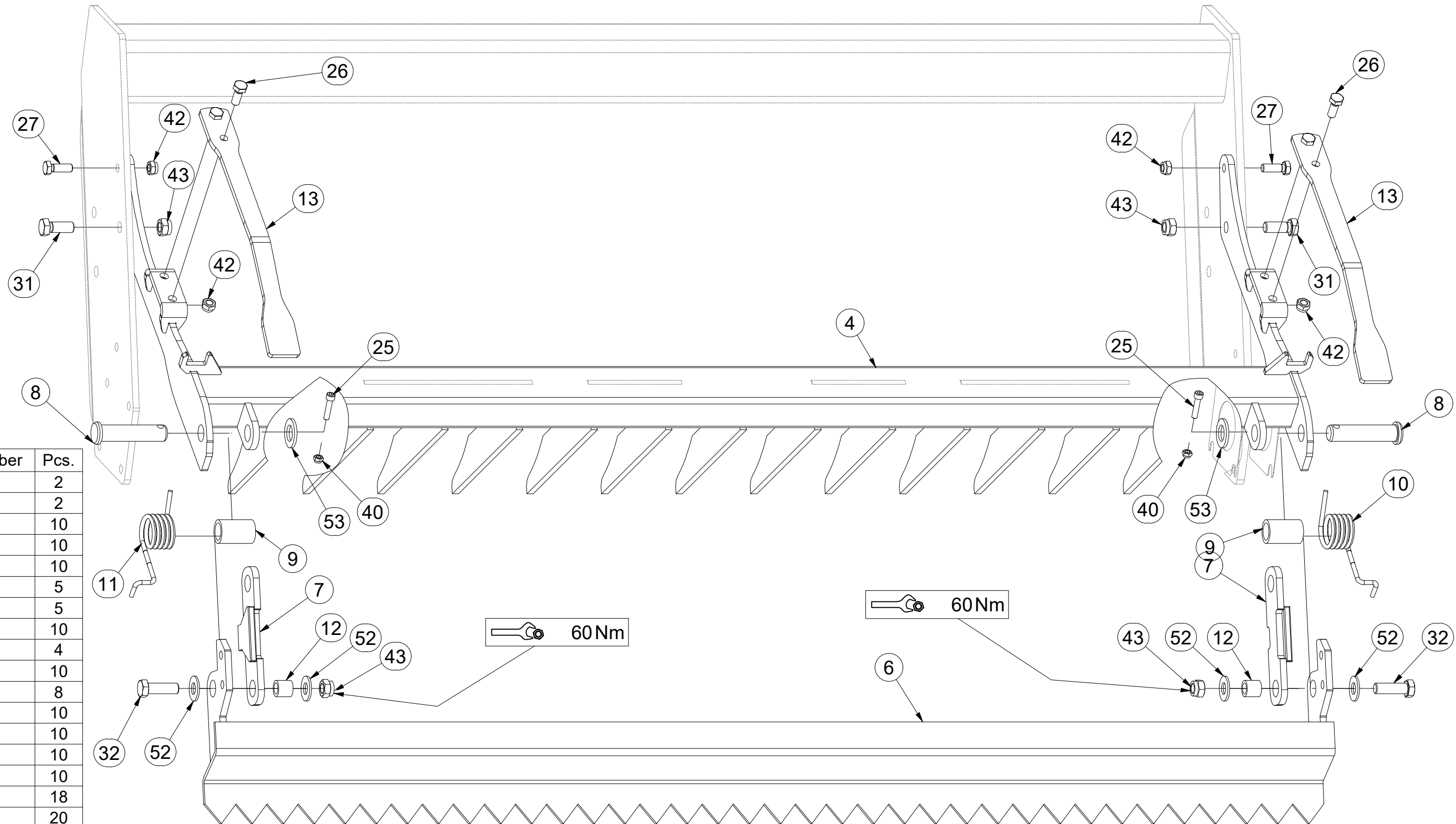
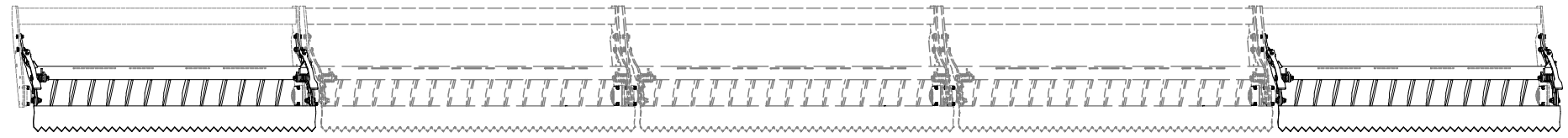

Pos.	Part Number	Pcs.
4	3011283	2
6	3003051	2
7	4024903	10
8	4015778	10
9	9002979	10
10	m12303	5
11	m12304	5
12	4022223	10
13	3011285	4
25	m09464	10
26	m11688	8
27	m04343	10
31	m01129	10
32	m04355	10
40	m04503	10
42	m04301	18
43	m03683	20
52	m05651	20
53	m14028	10

CZ SADA ZADNÍCH VÁLČŮ  
 D SATZ HINTERE WALZEN  
 F KIT DE ROULEAUX ARRIÈRE

GB SET OF REAR ROLLERS  
 RU КОМПЛЕКТ ЗАДНИХ КАТКОВ  
 PL ZESTAW TYLNYCH WAŁÓW



**VZ00031011**

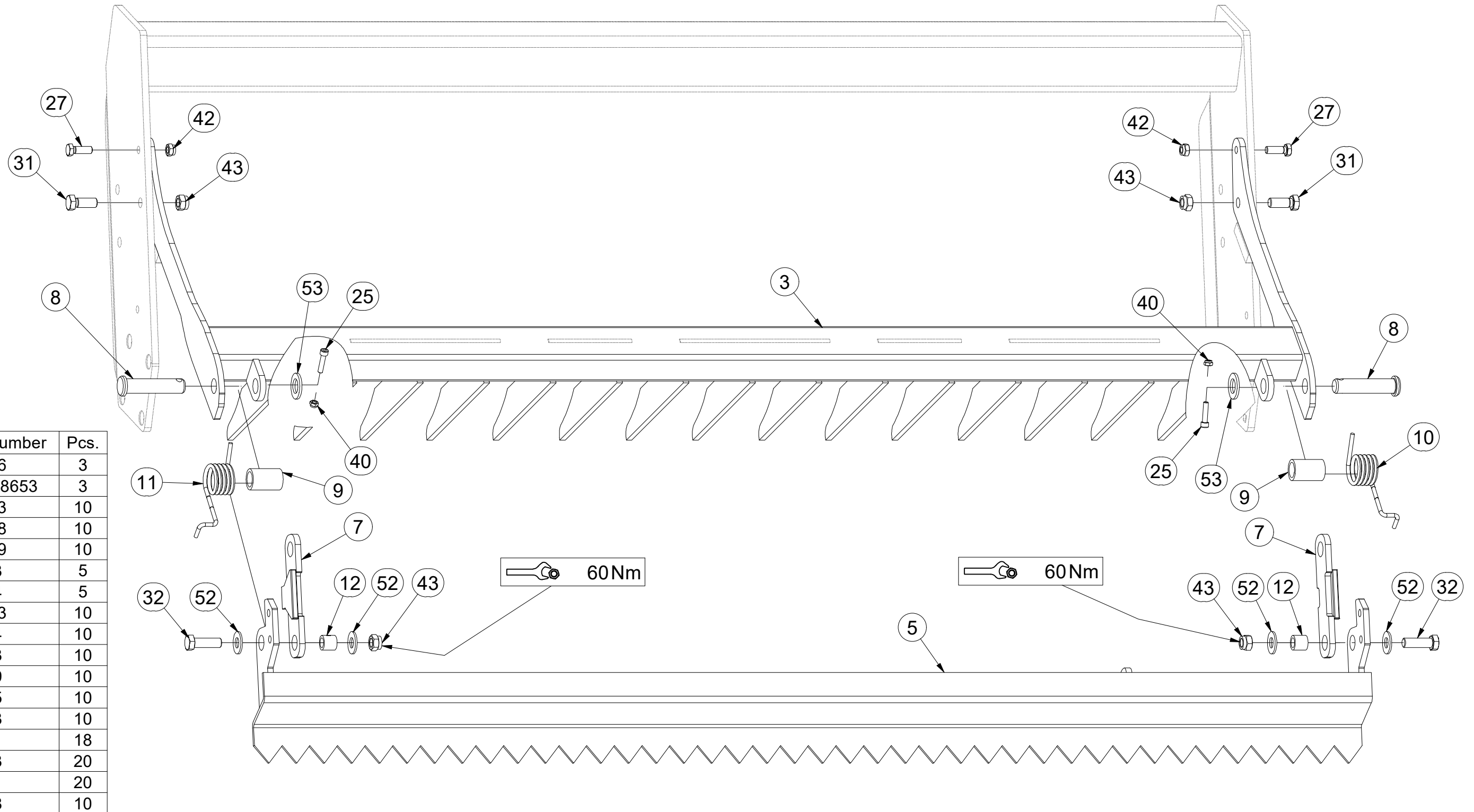
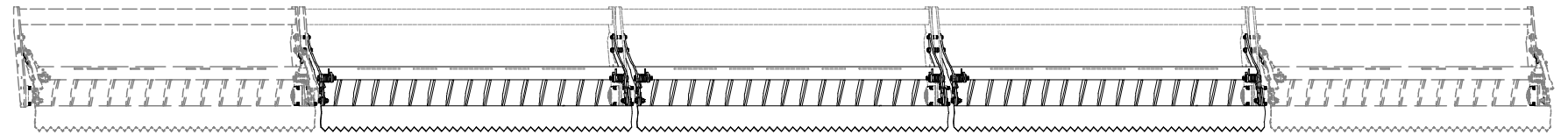

Pos.	Part Number	Pcs.
3	3004896	3
5	VZ00018653	3
7	4024903	10
8	4015778	10
9	9002979	10
10	m12303	5
11	m12304	5
12	4022223	10
25	m09464	10
27	m04343	10
31	m01129	10
32	m04355	10
40	m04503	10
42	m04301	18
43	m03683	20
52	m05651	20
53	m14028	10

CZ SADA ZADNÍCH VÁLČŮ  
 D SATZ HINTERE WALZEN  
 F KIT DE ROULEAUX ARRIÈRE

GB SET OF REAR ROLLERS  
 RU КОМПЛЕКТ ЗАДНИХ КАТКОВ  
 PL ZESTAW TYLNYCH WAŁÓW



**VZ00031011**

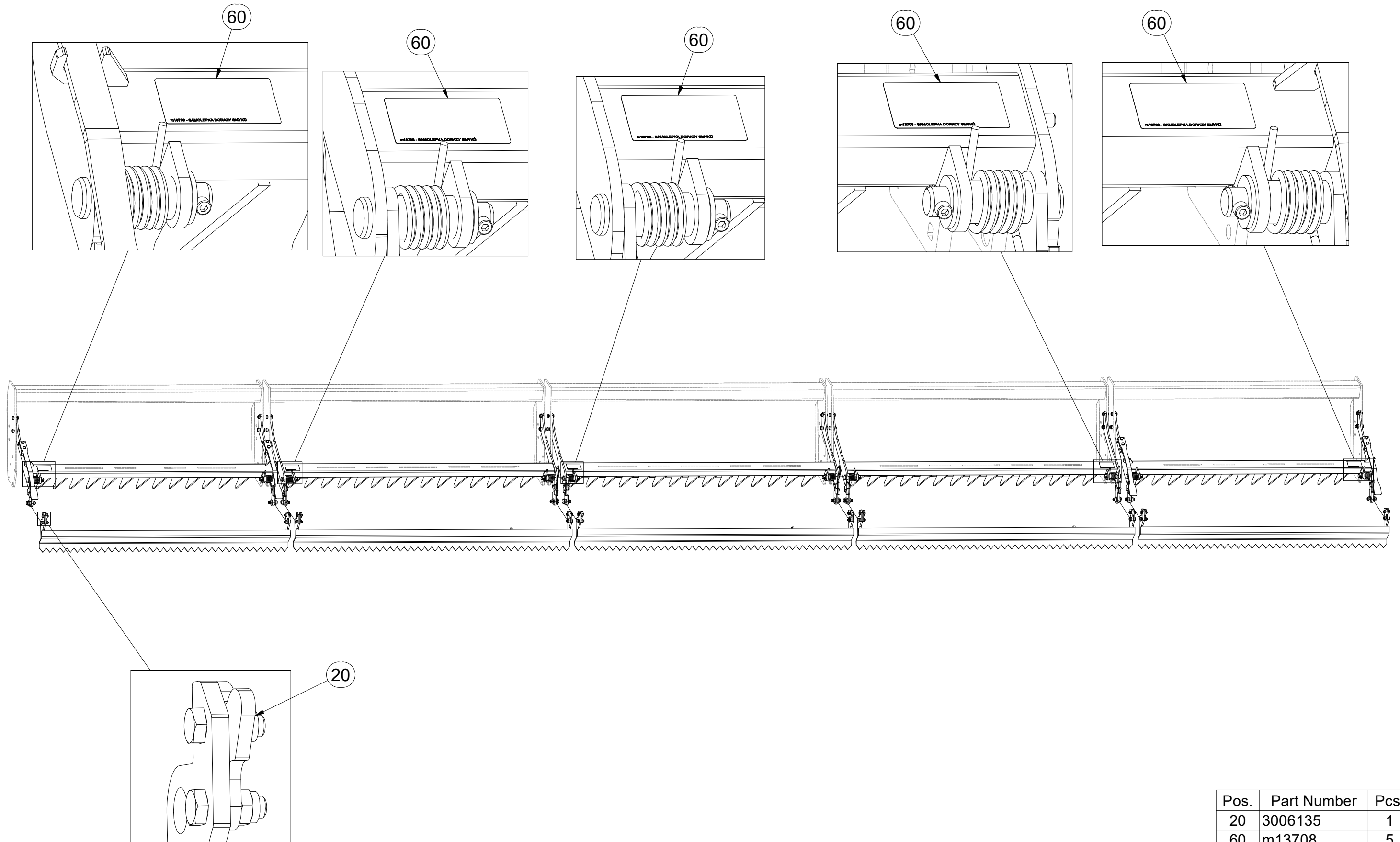

Pos.	Part Number	Pcs.
20	3006135	1
60	m13708	5

Ⓒ SADA ZADNÍCH VÁLCŮ  
Ⓓ SATZ HINTERE WALZEN  
Ⓕ KIT DE ROULEAUX ARRIÈRE

Ⓖ SET OF REAR ROLLERS  
Ⓡ КОМПЛЕКТ ЗАДНИХ КАТКОВ  
Ⓟ ZESTAW TYLNYCH WAŁÓW

**Farmet**

**VZ00018566**

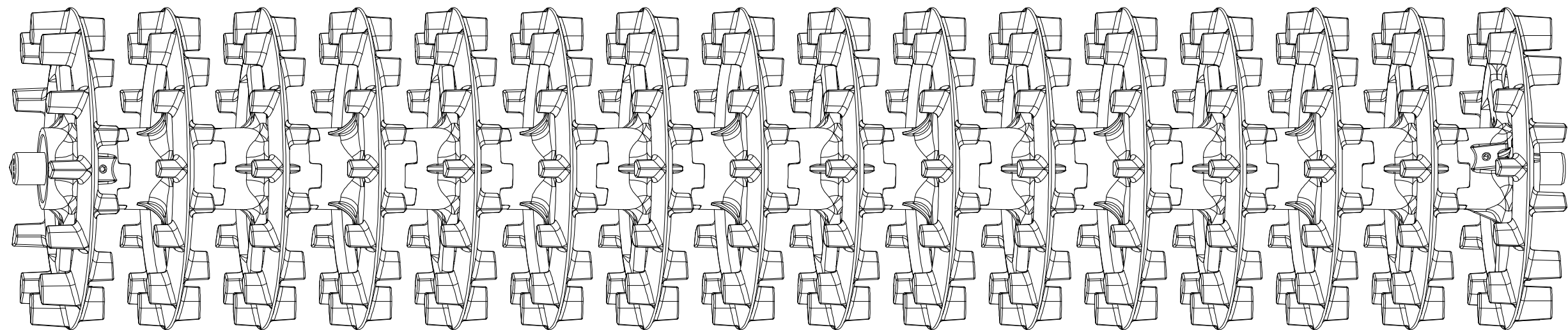
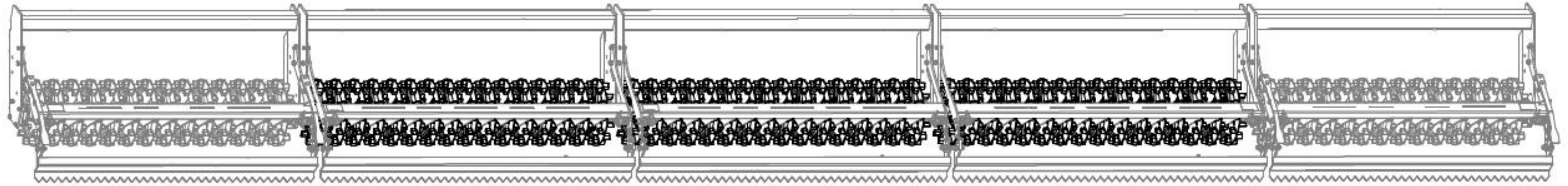

CZ SADA ZADNÍCH VÁLCŮ  
 D SATZ HINTERE WALZEN  
 F KIT DE ROULEAUX ARRIÈRE

GB SET OF REAR ROLLERS  
 RU КОМПЛЕКТ ЗАДНИХ КАТКОВ  
 PL ZESTAW TYLNYCH WAŁÓW



**VZ00018566**

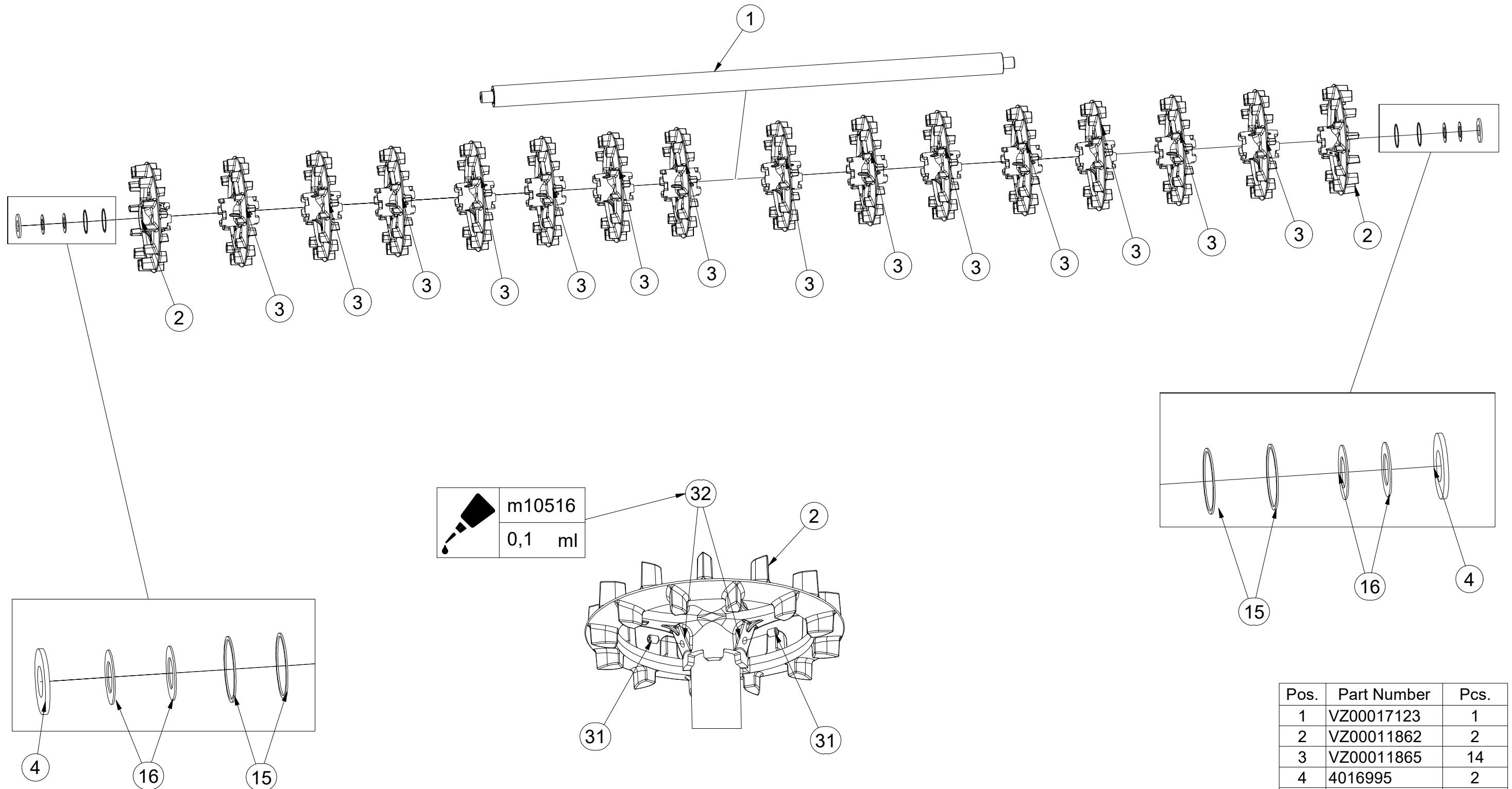

Pos.	Part Number	Pcs.
1	VZ00017123	1
2	VZ0001862	2
3	VZ0001865	14
4	4016995	2
15	4010015	4
16	4024556	4
31	m13958	4
32	m10516	0,00 ml

Ⓒ SADA ZADNÍCH VÁLCŮ

Ⓓ SATZ HINTERE WALZEN

Ⓕ KIT DE ROULEAUX ARRIÈRE

**VZ00023214**

Ⓖ SET OF REAR ROLLERS

Ⓡ КОМПЛЕКТ ЗАДНИХ КАТКОВ

Ⓟ ZESTAW TYLNYCH WAŁÓW

**Farmet**

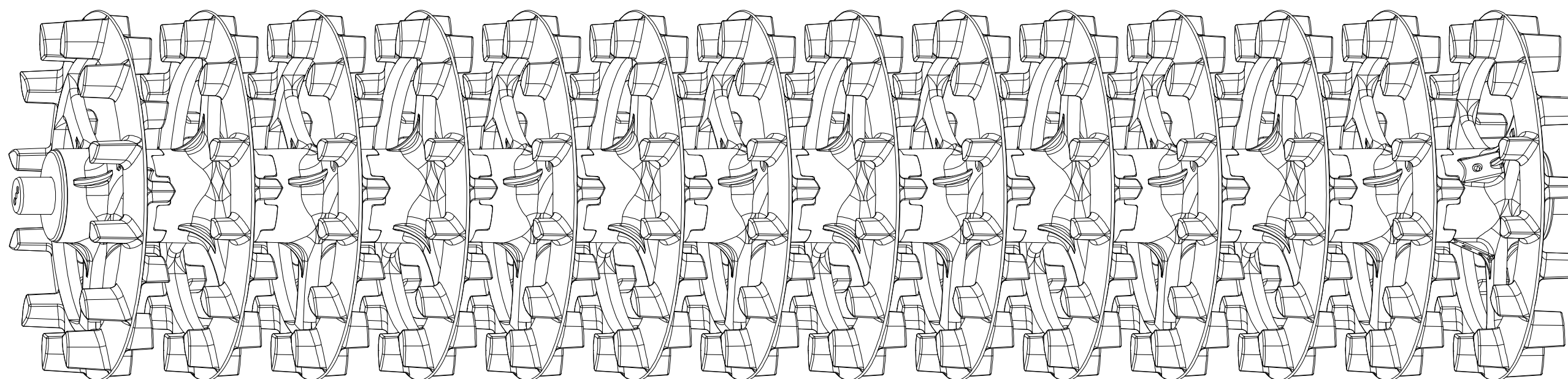
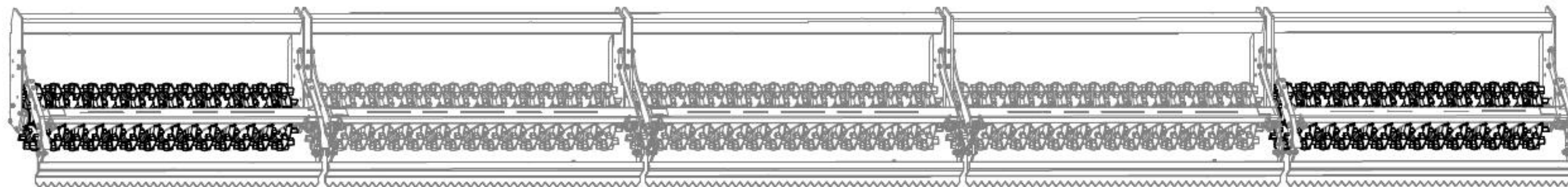



CZ SADA ZADNÍCH VÁLCŮ  
 D SATZ HINTERE WALZEN  
 F KIT DE ROULEAUX ARRIÈRE

GB SET OF REAR ROLLERS  
 RU КОМПЛЕКТ ЗАДНИХ КАТКОВ  
 PL ZESTAW TYLNYCH WAŁÓW



**VZ00023214**

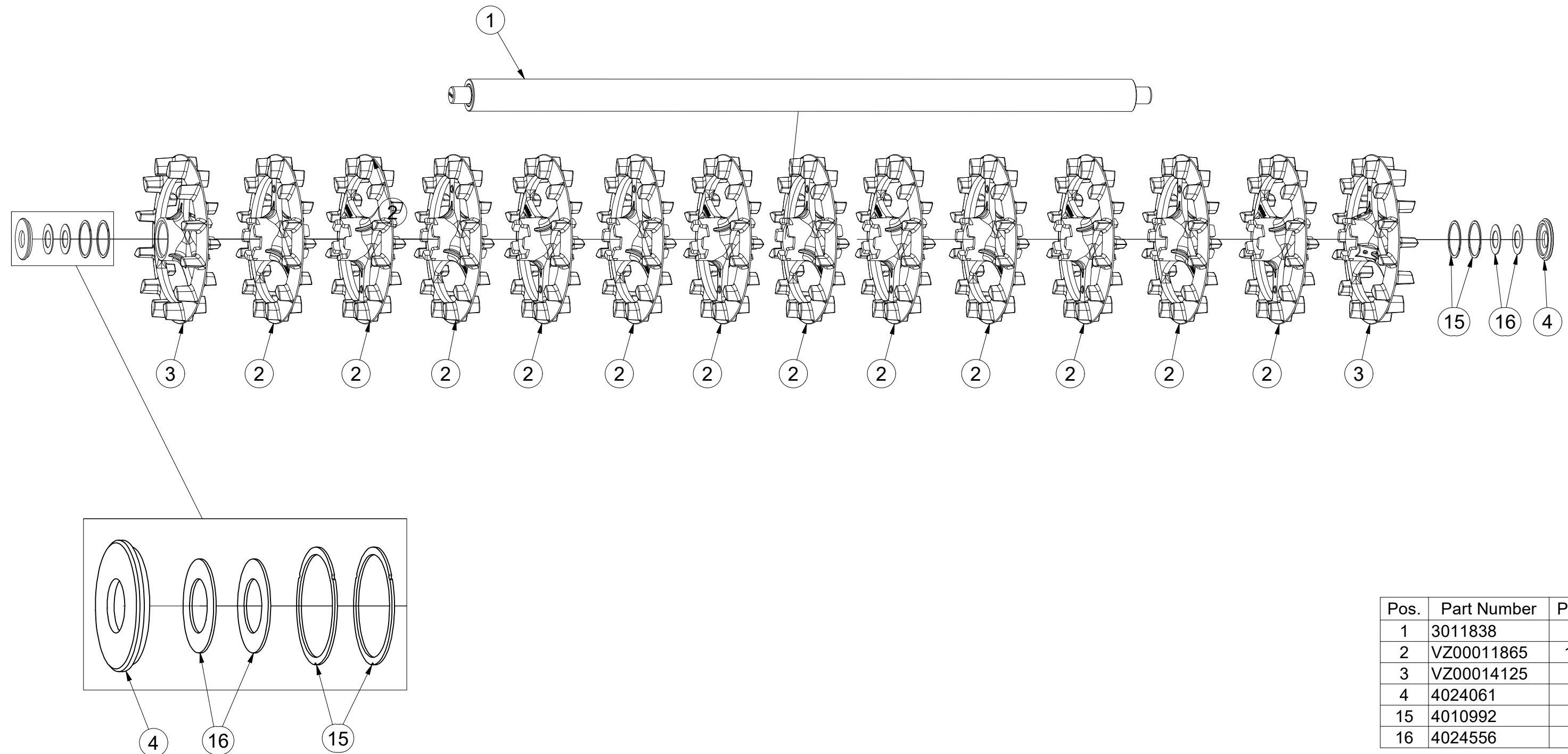

Pos.	Part Number	Pcs.
1	3011838	1
2	VZ00011865	12
3	VZ00014125	2
4	4024061	2
15	4010992	4
16	4024556	4

- Ⓒ SADA ZADNÍCH VÁLCŮ
- Ⓓ SATZ HINTERE WALZEN
- Ⓕ KIT DE ROULEAUX ARRIÈRE

- Ⓒ SET OF REAR ROLLERS
- Ⓓ КОМПЛЕКТ ЗАДНИХ КАТКОВ
- Ⓕ ZESTAW TYLNYCH WAŁÓW



**VZ00023214**

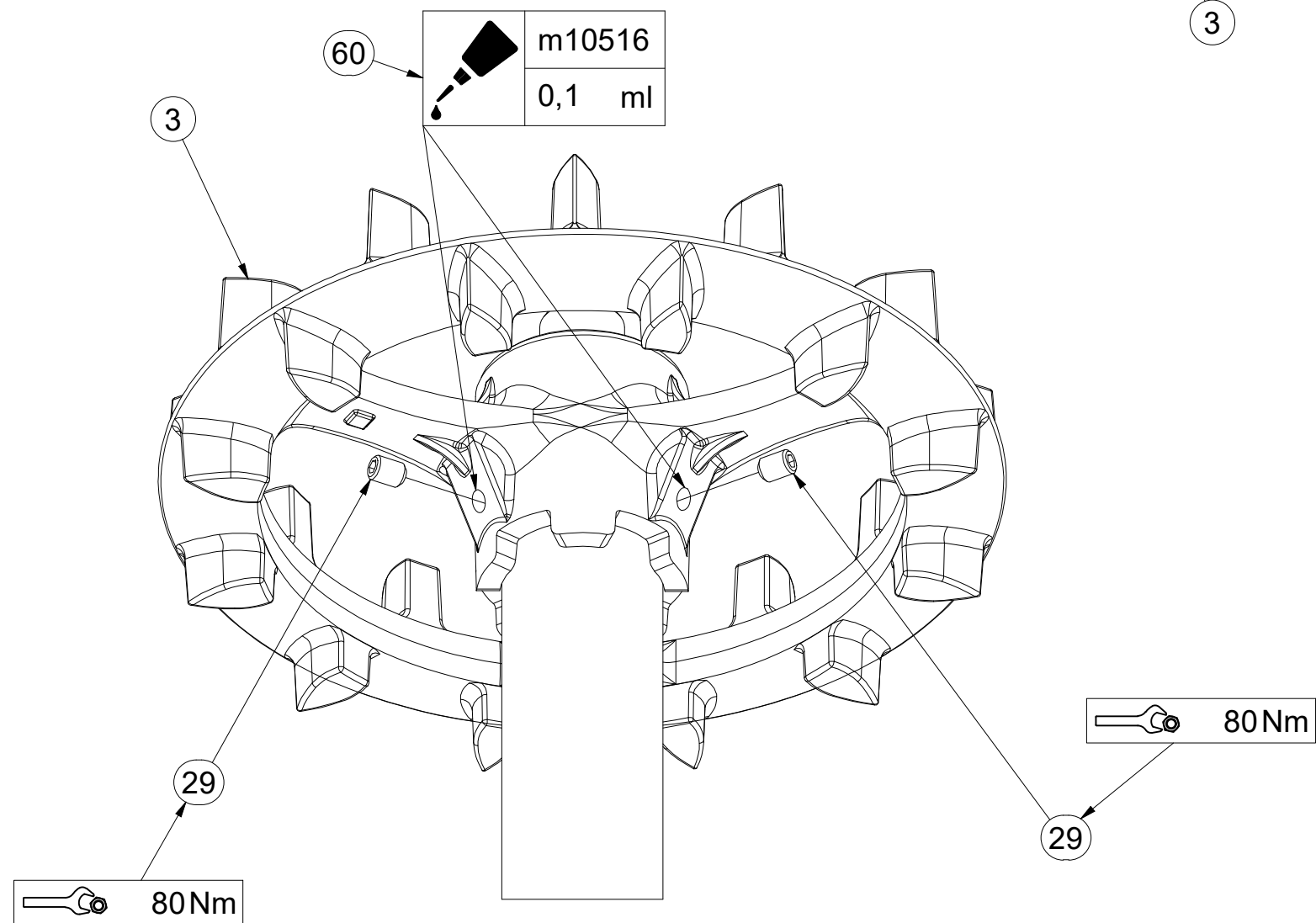
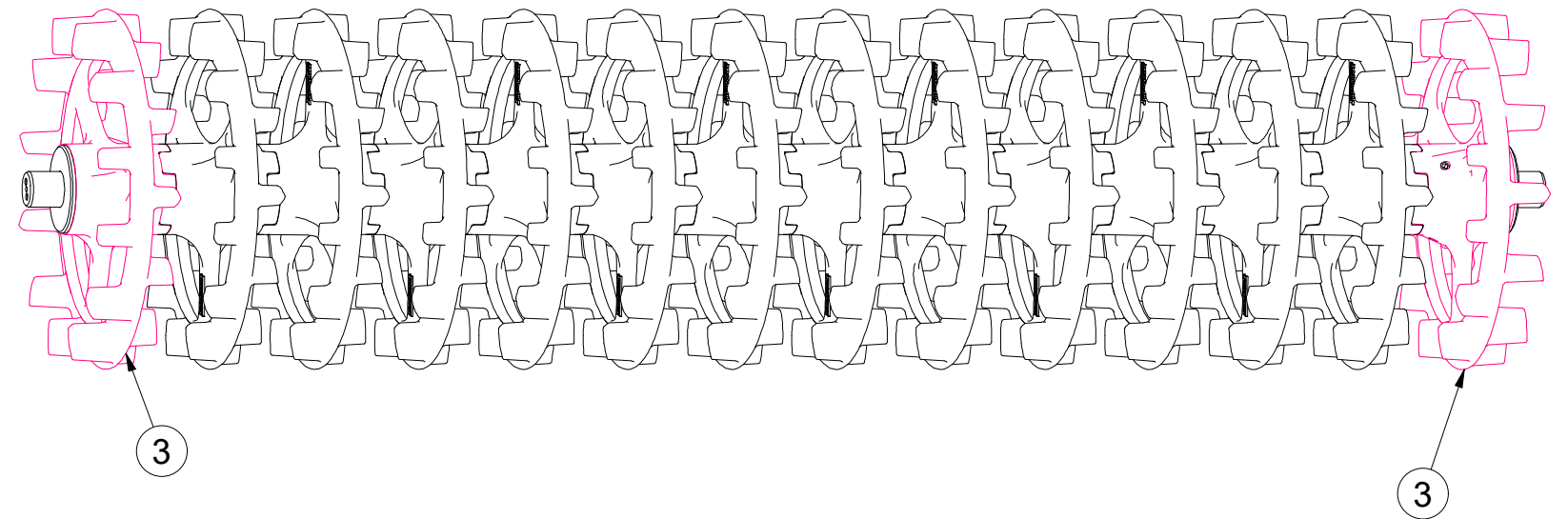

Pos.	Part Number	Pcs.
3	VZ00014125	2
29	m13958	4
60	m10516	0,40 ml

- ⒸZ SADA LOŽISEK
- Ⓓ SATZ LAGER
- Ⓕ F KIT DE ROULEMENTS

- ⒸB SET OF BEARINGS
- ⒸR КОМПЛЕКТ ПОДШИПНИКОВ
- ⒸL ZESTAW ŁOŻYSK



**VZ00012472**

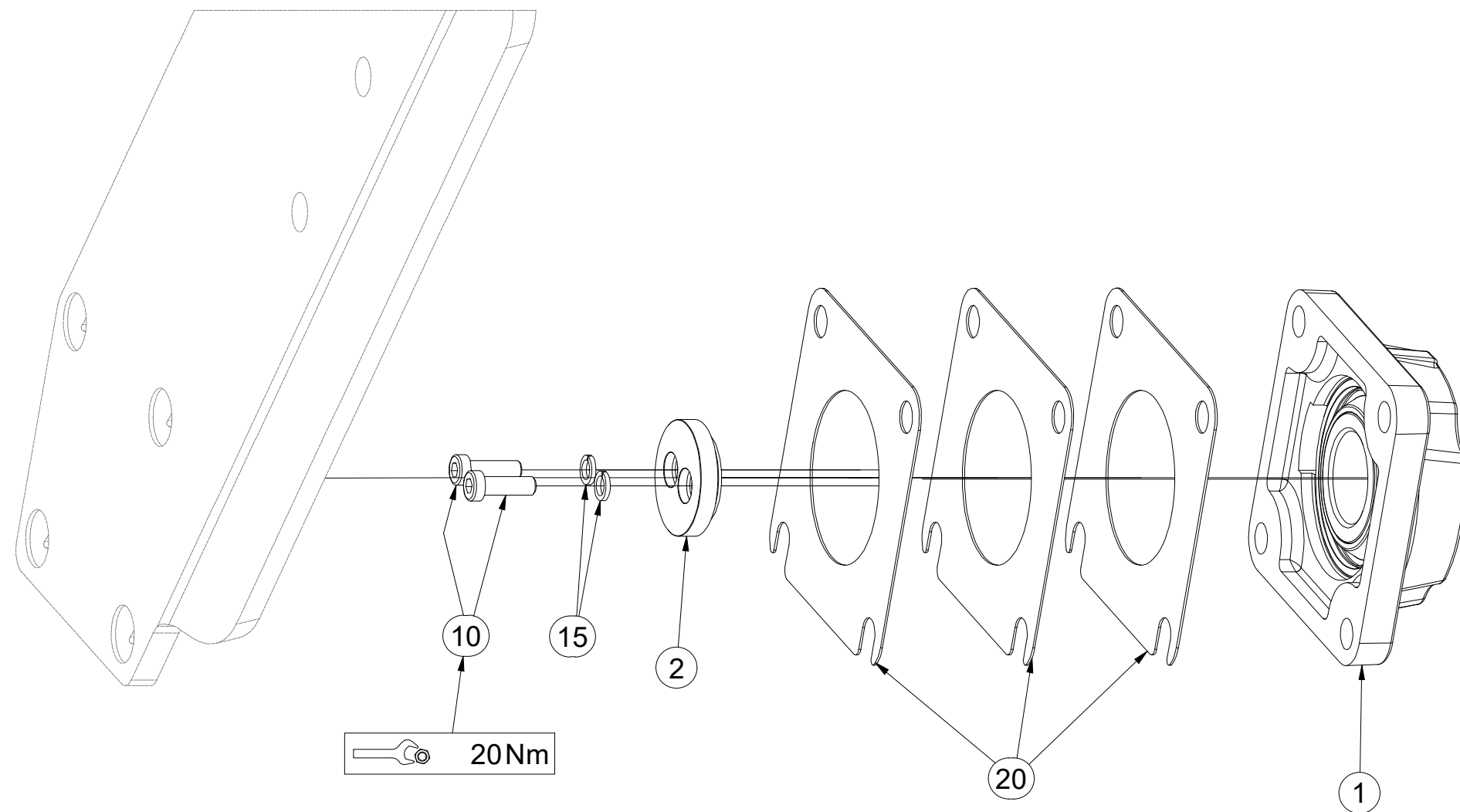
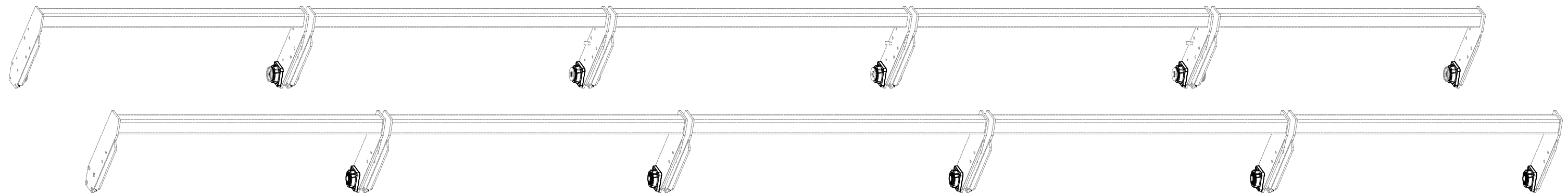

Pos.	Part Number	Pcs.
1	m18650	20
2	4024753	20
10	m23338	40
15	m01202	40
20	4016809	60

ⒸZ SADA DORAZŮ ZADNÍCH SMYKŮ

Ⓓ ANSCHLAGSATZ FÜR HINTERE ACKERSCHLEPPEN

Ⓕ KIT DE BUTÉES DES NIVELEURS ARRIÈRE

**3006135**

ⒼB SET OF REAR LEVELLING BAR STOPS

ⓇU КОМПЛЕКТ УПОРОВ ЗАДНИХ БОРОН

ⓅL ZESTAW DOCISKÓW TYLNYCH WŁÓK

**Farmet**

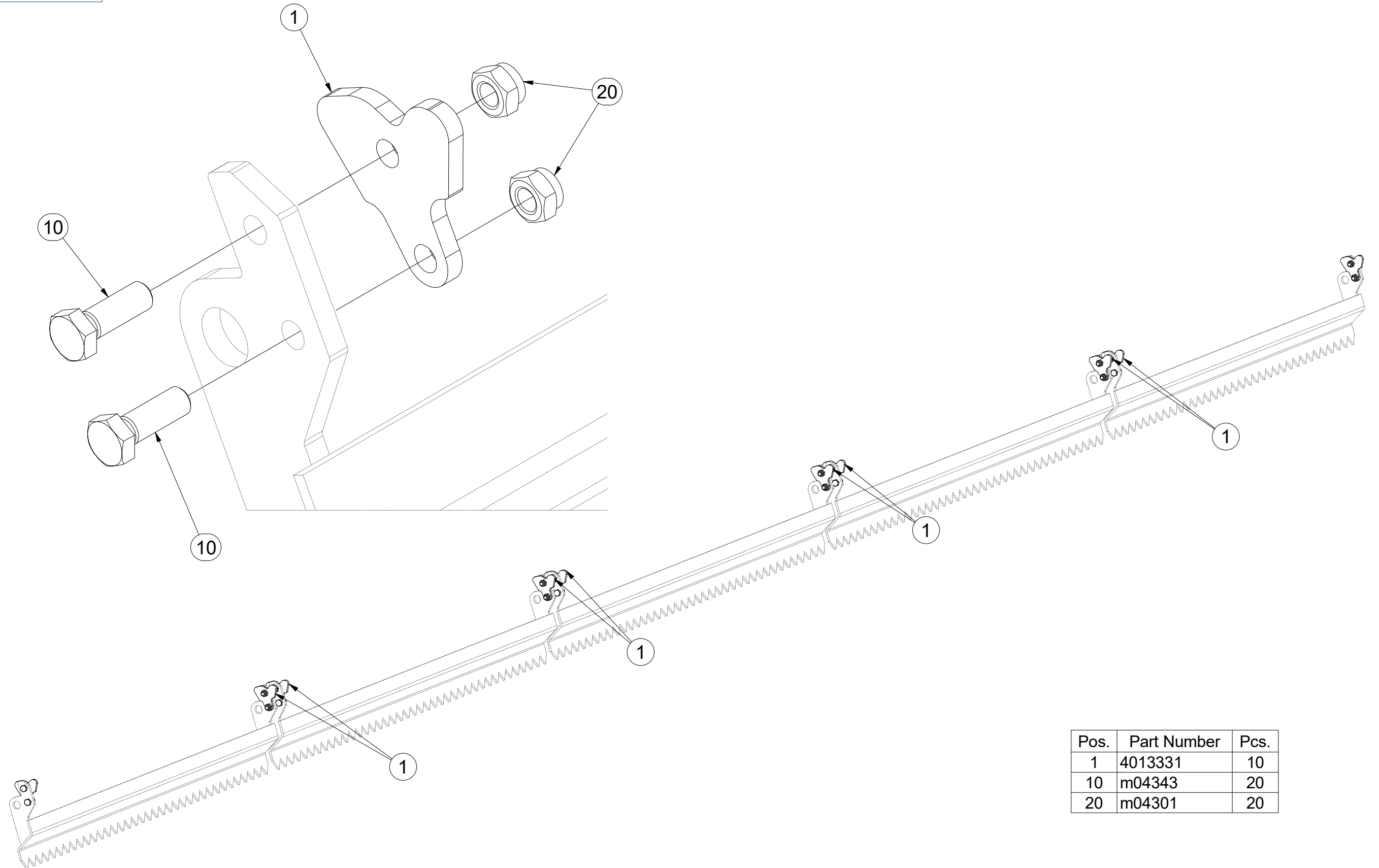

Pos.	Part Number	Pcs.
1	4013331	10
10	m04343	20
20	m04301	20

Ⓒ CZ SADA NÁPRAVY

Ⓓ D SATZ AUFHÄNGUNG

Ⓕ F KIT DE L'ESSIEU

Ⓒ GB AXLE SET

Ⓒ RU КОМПЛЕКТ ОСИ КОЛЁС

Ⓒ PL ZESTAW OSI

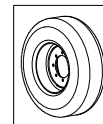

**3012633**

	M18x1,5-265Nm
	280 kPa

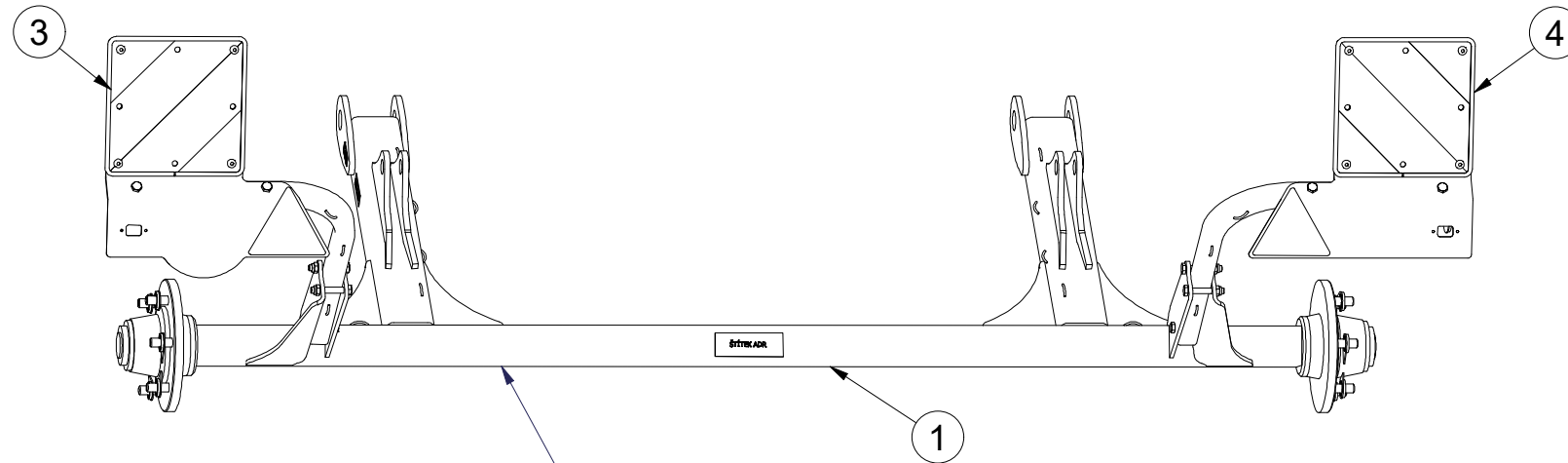

# A80RM600

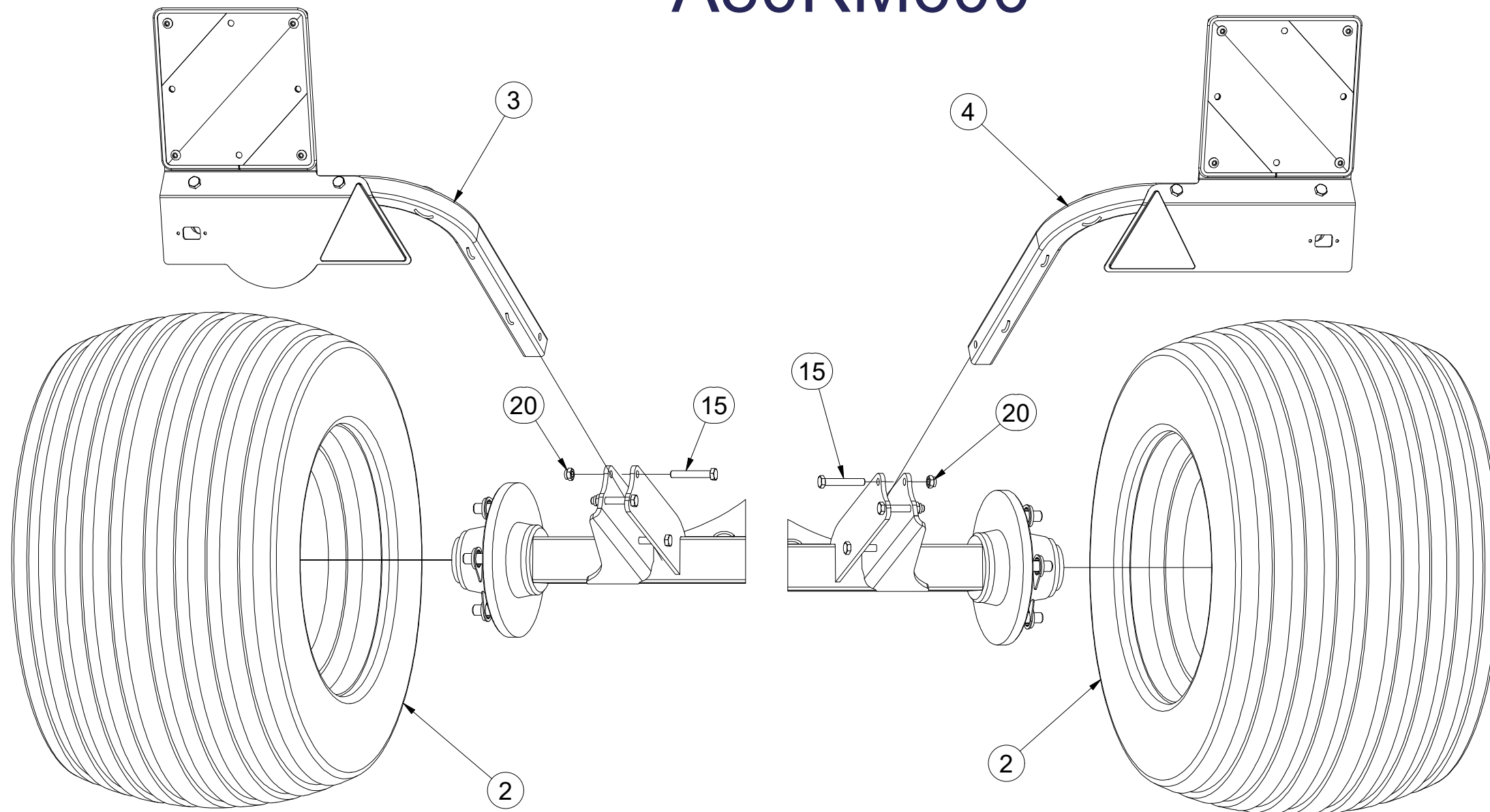
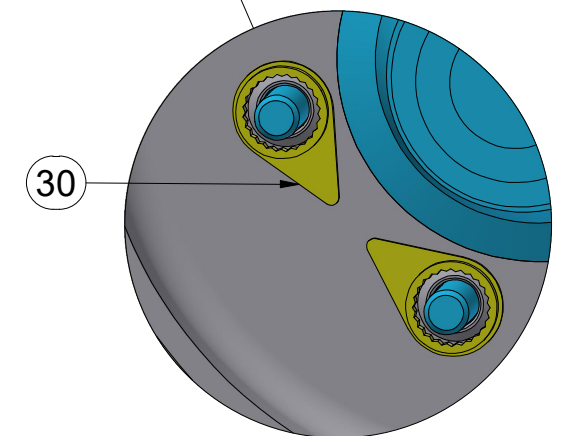
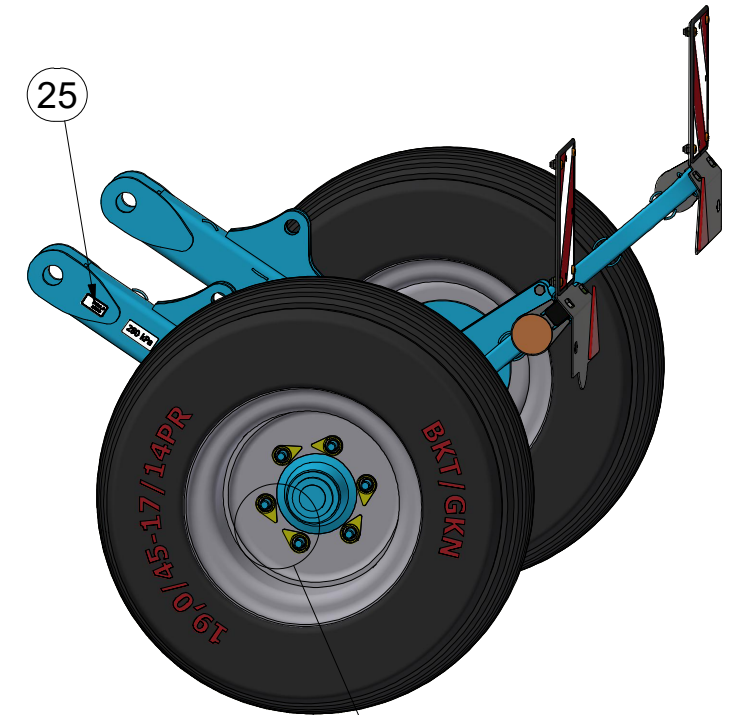

Pos.	Part Number	Pcs.
1	3012632	1
2	m19870	2
3	3012367	1
4	3012389	1
15	m12493	6
20	m04301	6
25	m19732	2
30	m19657	12

ⒸZ NÁPRAVA

ⒹACHSE

ⒻESSIEU

ⒸGB AXLE

ⒸRU OCB

ⒸPL OS



**A80RM600**

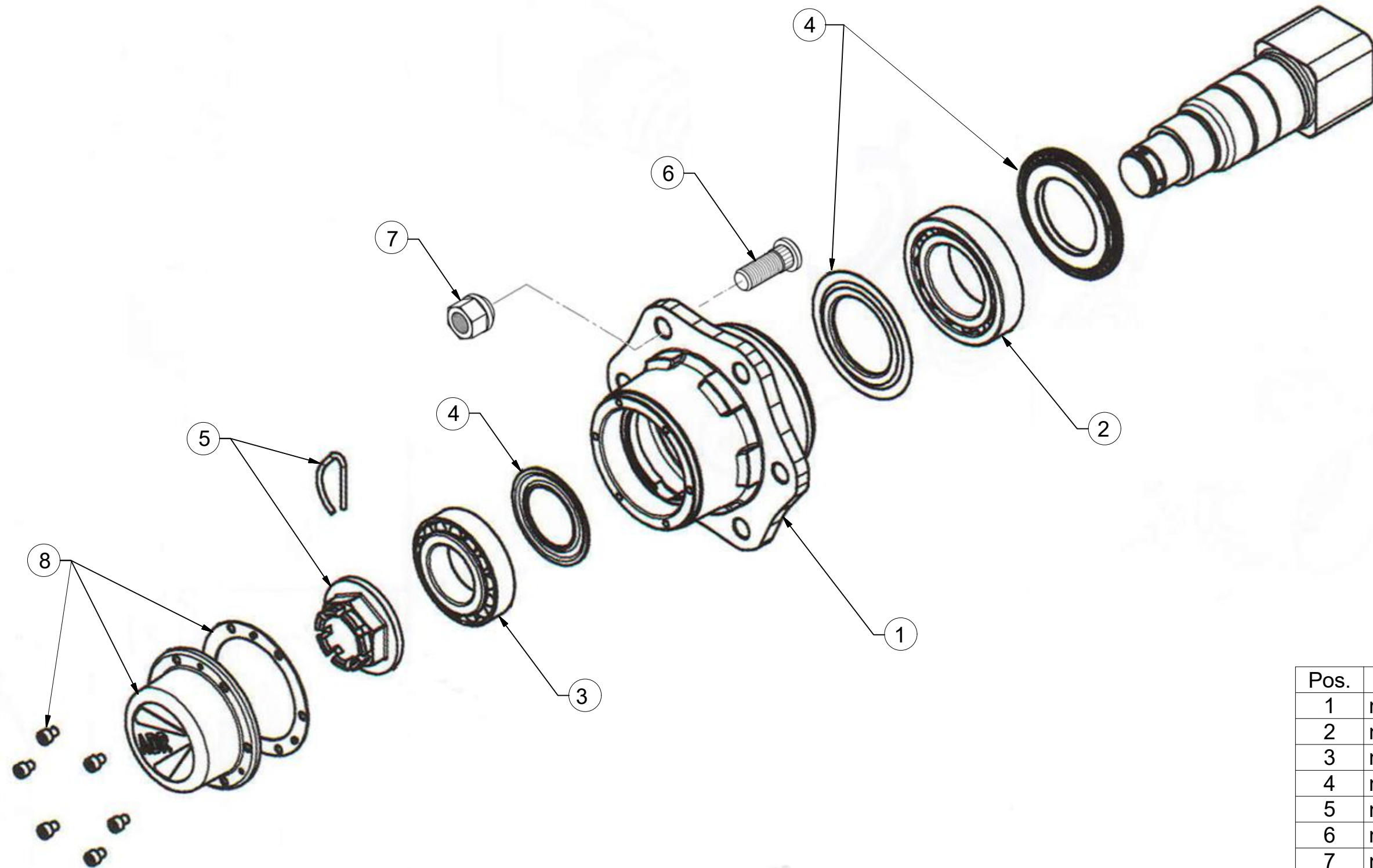

Pos.	Part Number	Pcs.
1	m12567	2
2	m07153	2
3	m07154	2
4	m12565	2
5	m08168	2
6	m08148	12
7	m08163	12
8	m12566	2

ⒸZ TERČ ZADNÍ LEVÝ

Ⓓ SCHILD, HINTERES, LINKES

Ⓕ CIBLE ARRIÈRE GAUCHE

**3012367**

ⒸB LEFT REAR DISC

Ⓔ ЩИТОК ЗАДНИЙ ЛЕВЫЙ

Ⓗ TARCZA TYLNA LEWA

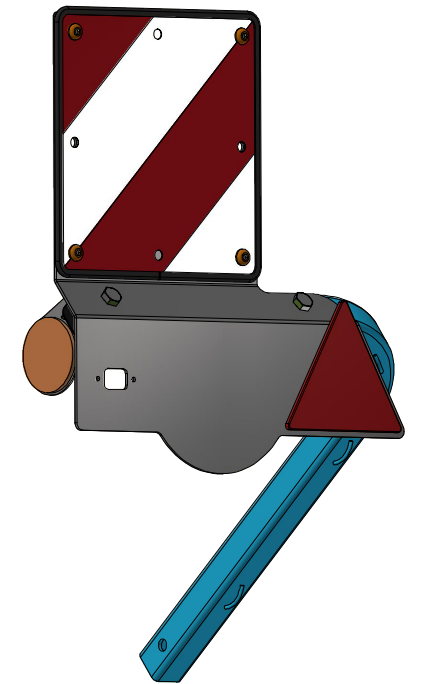
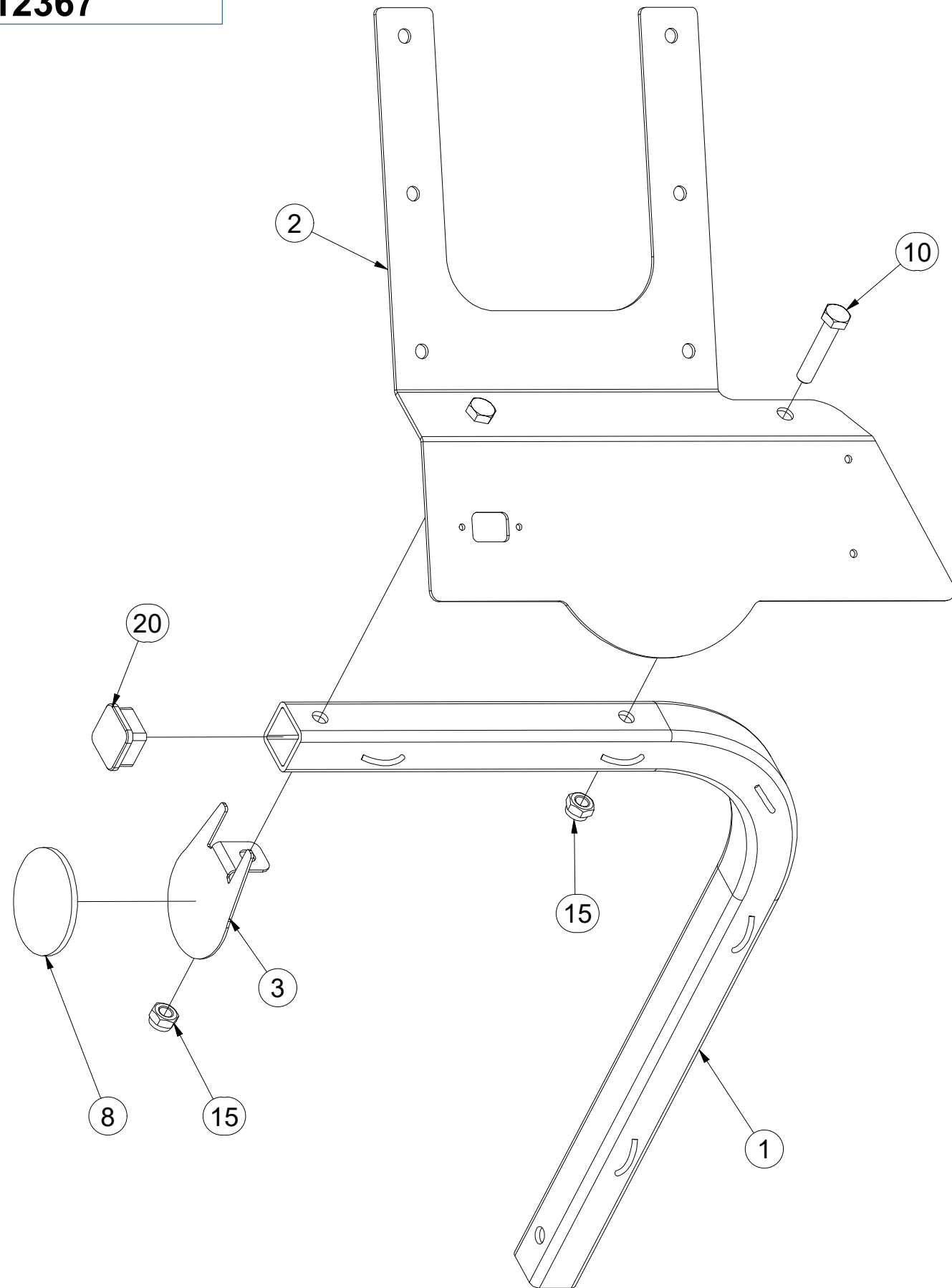

Pos.	Part Number	Pcs.
1	3012364	1
2	3012365	1
3	4024926	1
8	m02579	1
10	m01131	2
15	m04301	2
20	m12689	1

ⒸZ TERČ ZADNÍ LEVÝ

Ⓓ SCHILD, HINTERES, LINKES

Ⓕ CIBLE ARRIÈRE GAUCHE

ⒼB LEFT REAR DISC

ⒶU ЩИТОК ЗАДНИЙ ЛЕВЫЙ

ⒶL TARCZA TYLNA LEWA



**3012367**

Pos.	Part Number	Pcs.
5	m18855	1
6	9005707	1
7	m02497	1
11	m16637	4
16	m03775	4
25	m01209	4

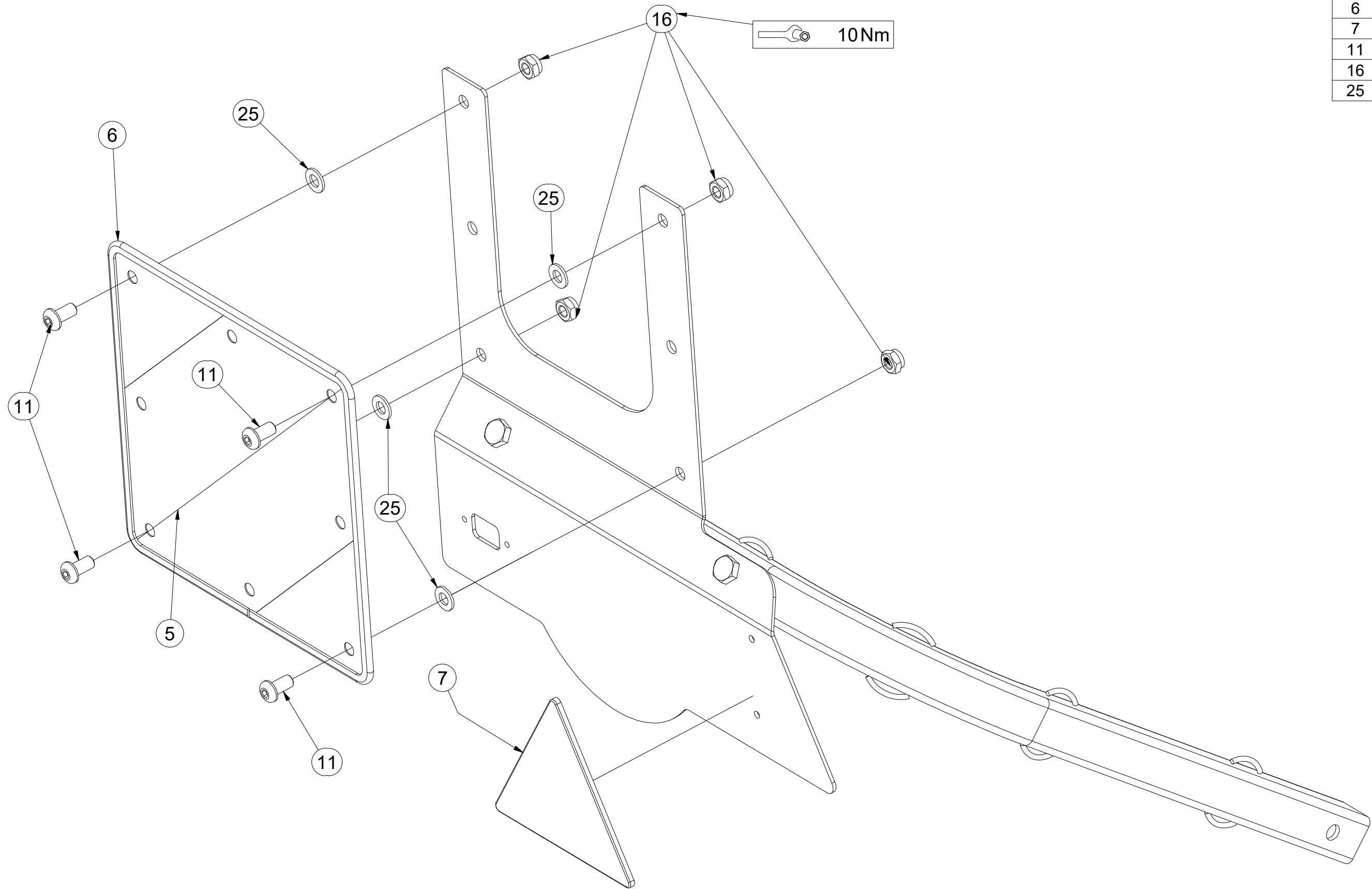



ⒸZ TERČ ZADNÍ PRAVÝ

Ⓓ SCHILD, HINTERES, RECHTES

Ⓕ CIBLE ARRIÈRE DROITE

**3012389**

ⒼB RIGHT REAR DISC

ⒺЩИТОК ЗАДНИЙ ПРАВЫЙ

ⒽL TARCZA TYLNA PRAWA

**Farmet**

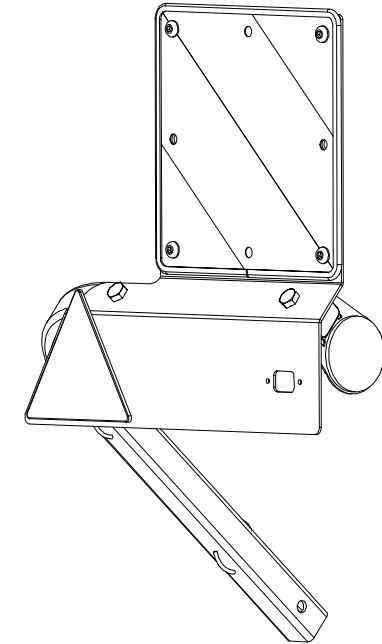
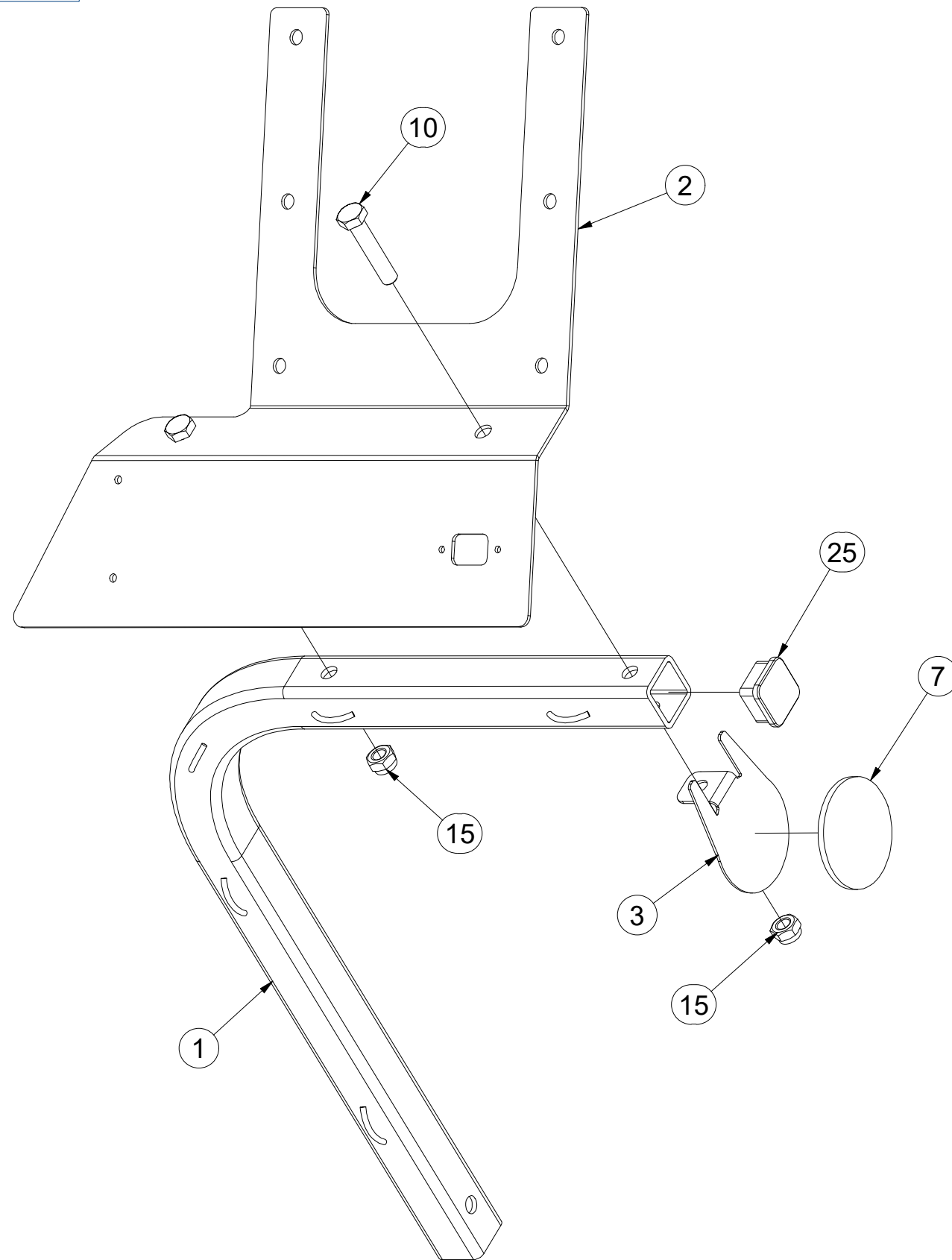

Pos.	Part Number	Pcs.
1	3012364	1
2	3012390	1
3	4024926	1
7	m02579	1
10	m01131	2
15	m04301	2
25	m12689	1

ⒸZ TERČ ZADNÍ PRAVÝ

Ⓓ SCHILD, HINTERES, RECHTES

Ⓕ CIBLE ARRIÈRE DROITE

ⒼB RIGHT REAR DISC

Ⓐ RU ЩИТОК ЗАДНИЙ ПРАВЫЙ

Ⓐ PL TARCZA TYLNA PRAWA

**Farmet**

**3012389**

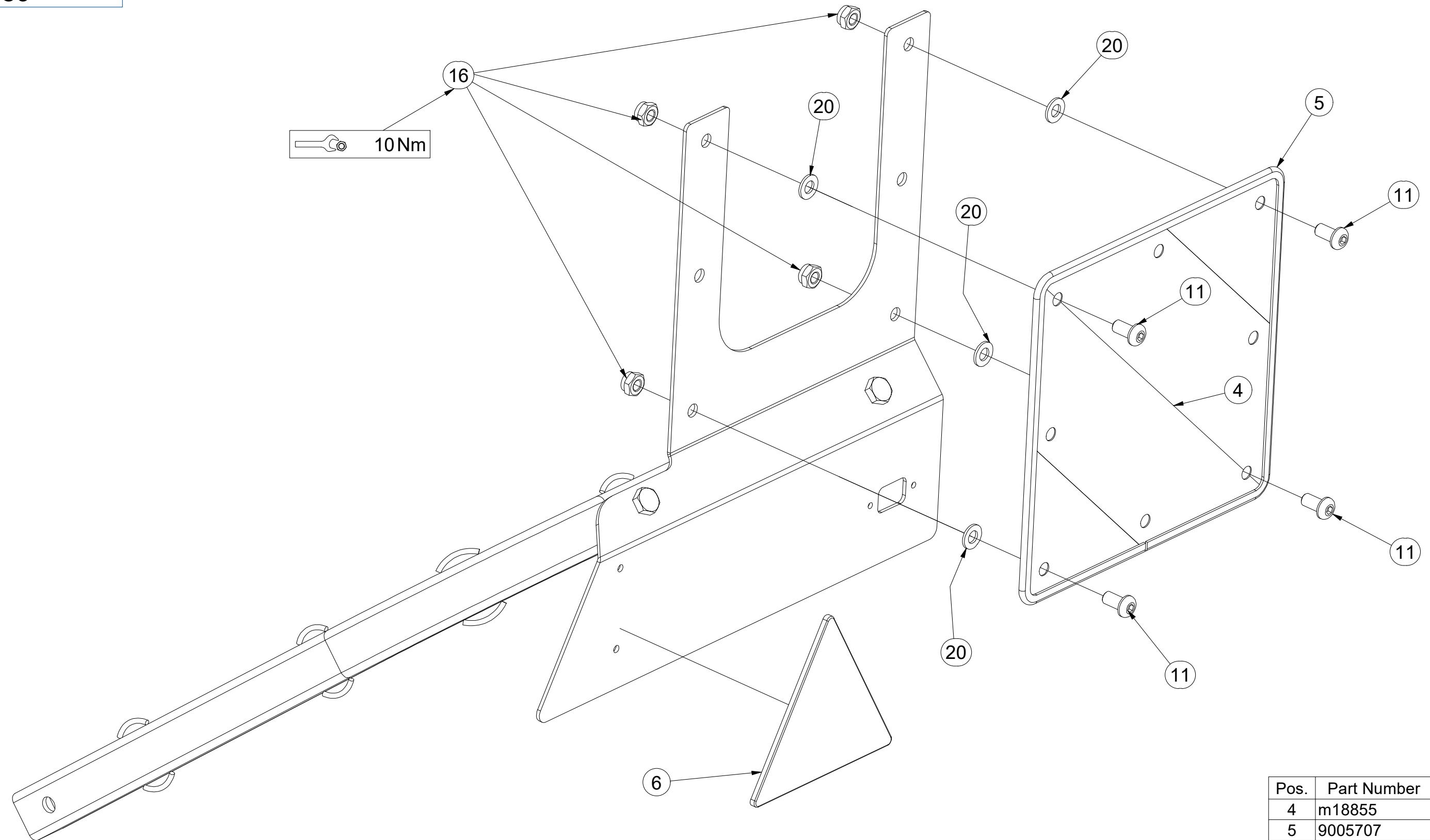

Pos.	Part Number	Pcs.
4	m18855	1
5	9005707	1
6	m02497	1
11	m16637	4
16	m03775	4
20	m01209	4

Ⓒ SAMOLEPKY STROJE

Ⓓ AUFKLEBER MASCHINEN

Ⓕ VOITURE MACHINES

Ⓖ STICKERS MACHINES

Ⓡ СТИКЕРЫ МАШИНЫ

Ⓟ NAKLEJKI MASZYNY



**4026236**

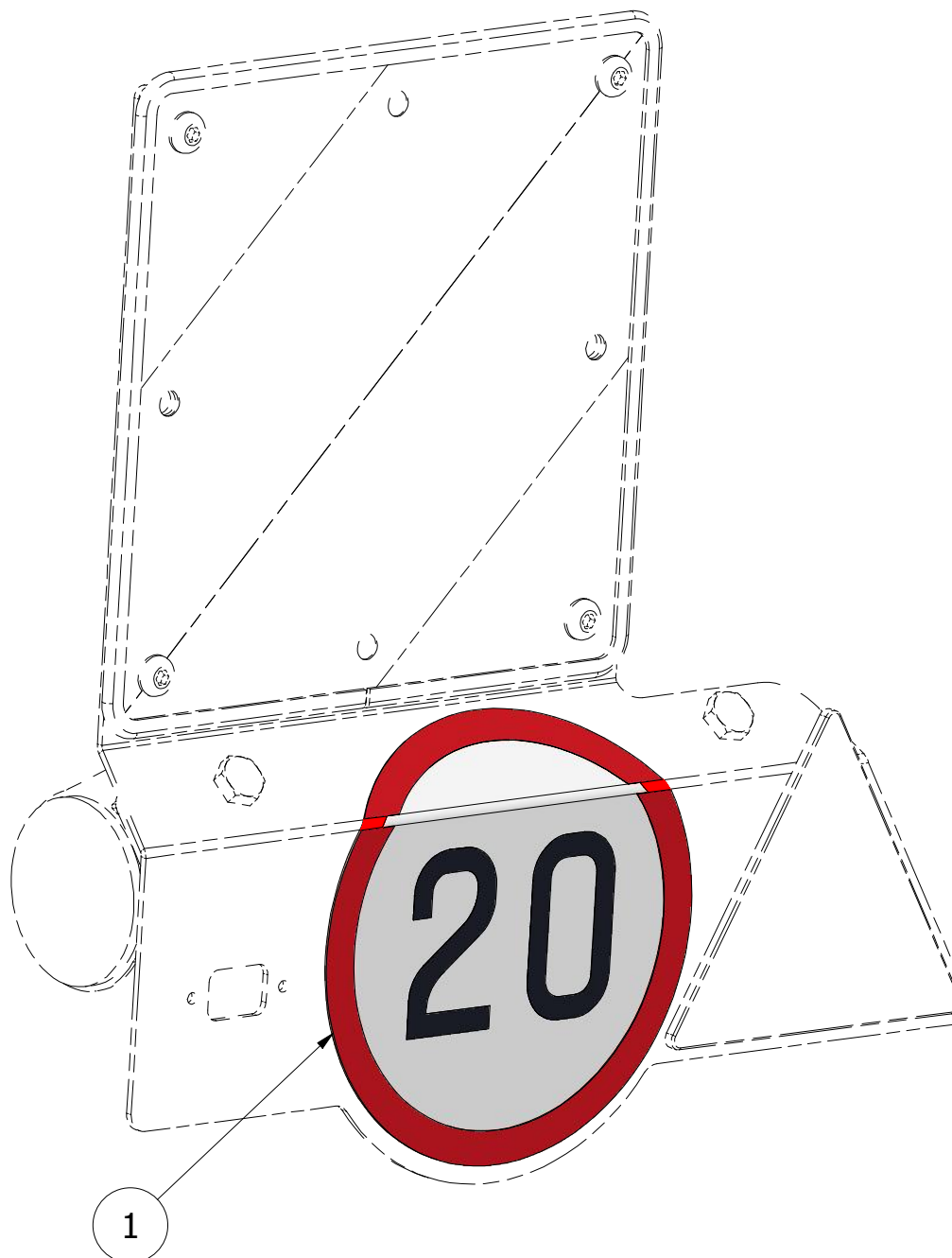

Pos.	Part Number	Pcs.
1	m04406	1

Ⓒ SOUPRAVA TĚSNIVA PÍSTNIC

Ⓓ KOLBENSTANGENDICHTUNGSMITTELSATZ

Ⓕ SET DE GARNITURE DES TIGES DE PISTON

Ⓖ SEALING SET FOR PISTON RODS

Ⓡ КОМПЛЕКТ ПРОКЛАДОК ЦИЛИНДРОВ

Ⓟ ZESTAW USZCZELEK TRZPIENIA TŁOKA

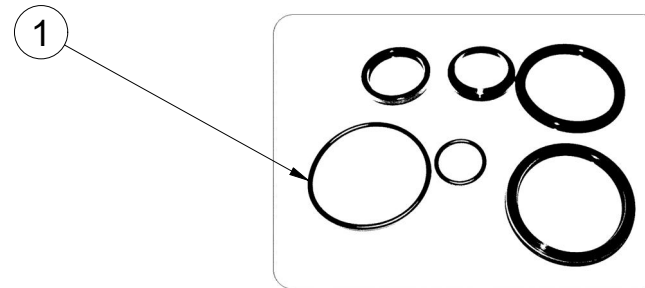
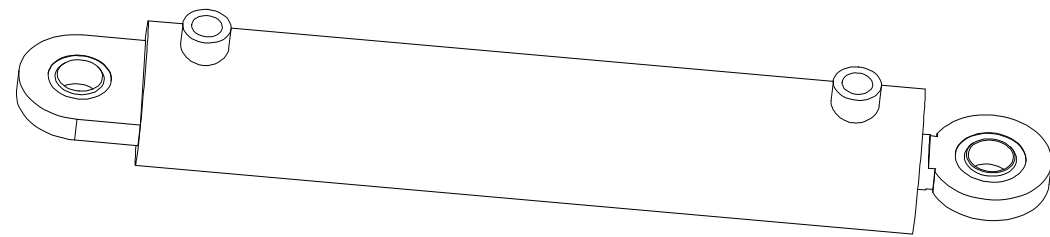

VZ00004544 - $\varnothing 80/\varnothing 40-400$		
Pos	Part number	Pcs
1	m20702	4

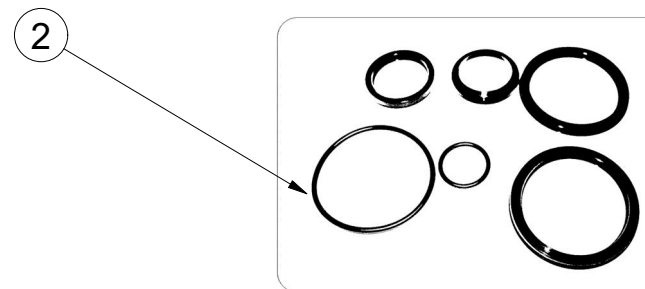
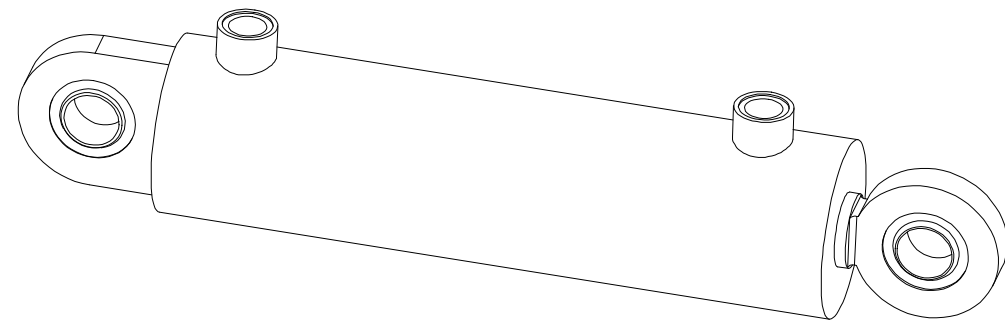

VZ00004549 - $\varnothing 80/\varnothing 40-250$		
Pos	Part number	Pcs
2	m20702	2

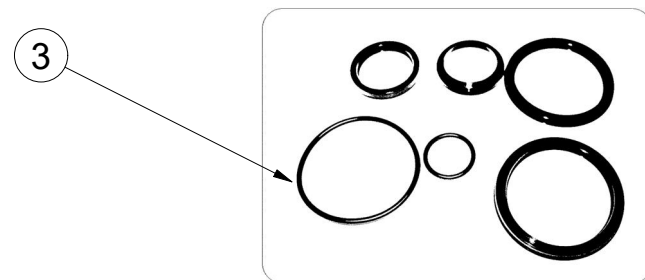
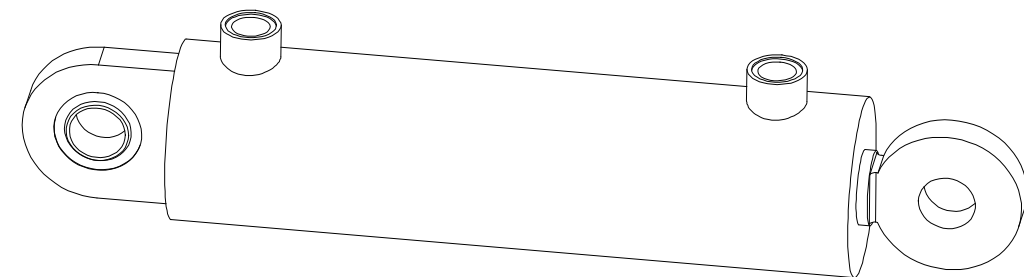

VZ00004551 - $\varnothing 80/\varnothing 40-250$		
Pos	Part number	Pcs
3	m20702	1

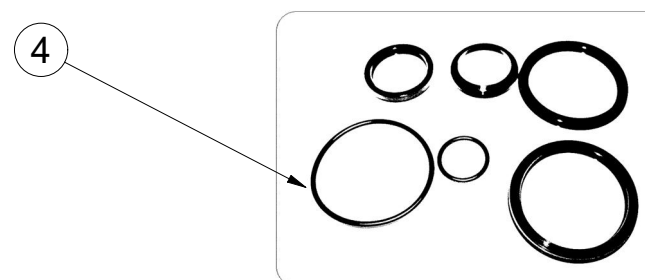
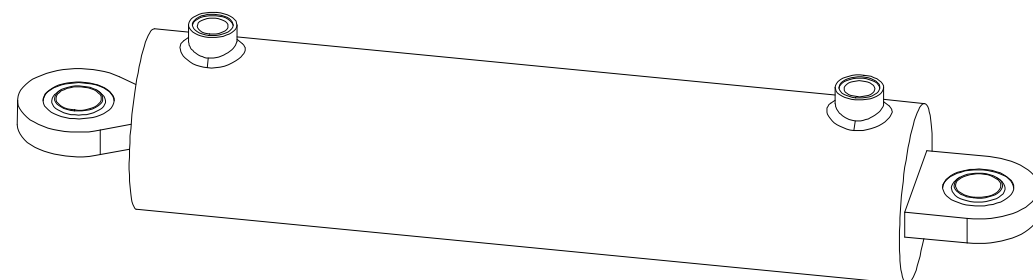

VZ00013004 - $\varnothing 100/\varnothing 45-400$		
Pos	Part number	Pcs
4	m05504	1

Ⓒ SVĚTELNÁ SADA

Ⓓ LEUCHTENSATZ

Ⓕ KIT LUMINEUX

Ⓖ LIGHTING SET

Ⓡ ОСВЕТИТЕЛЬНЫЙ КОМПЛЕКТ

Ⓟ ZESTAW OŚWIETLENIA



**3012742**

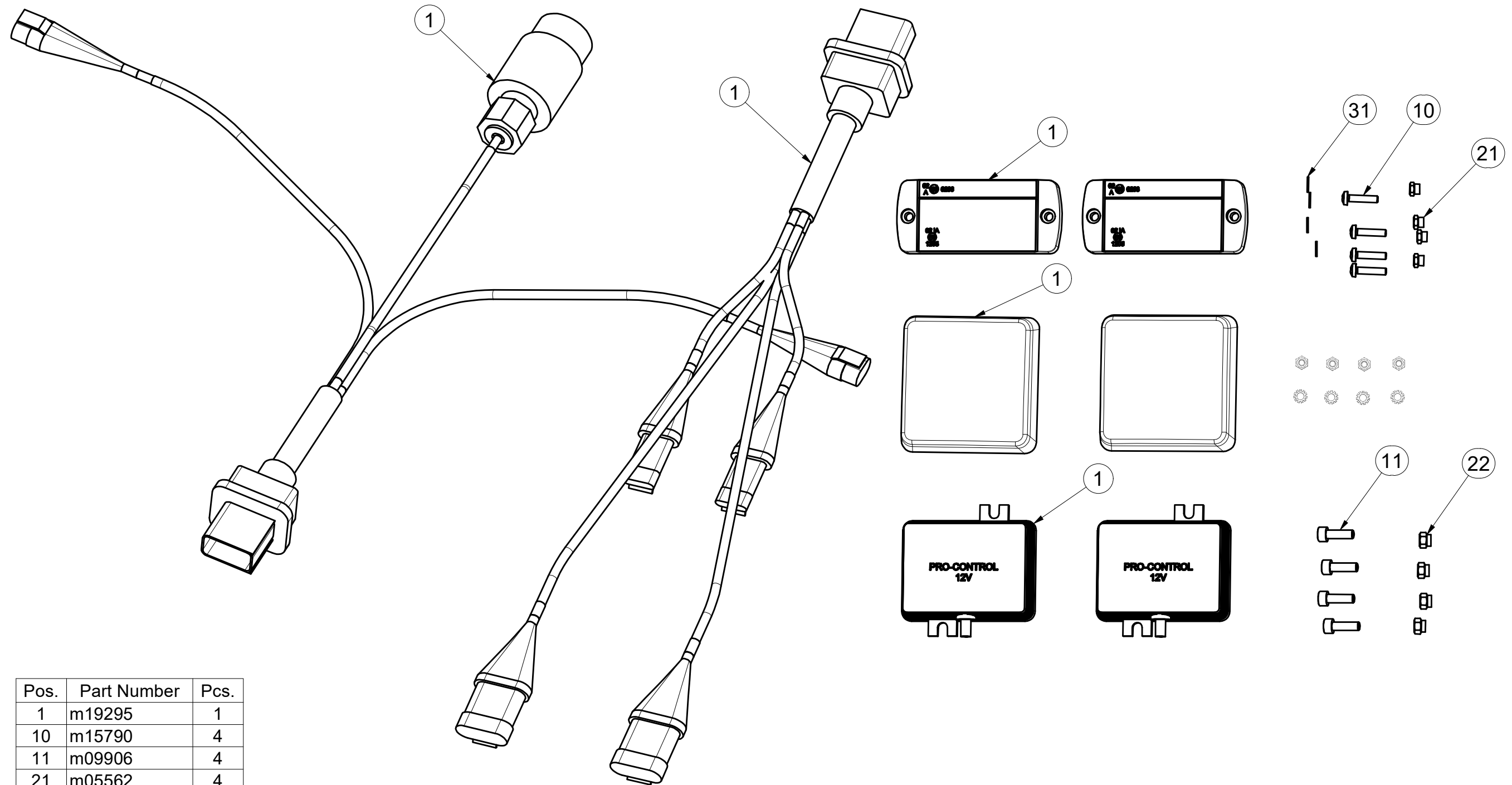

Pos.	Part Number	Pcs.
1	m19295	1
10	m15790	4
11	m09906	4
21	m05562	4
22	m06236	4
31	m05597	4

Ⓒ SVĚTELNÁ SADA

Ⓓ LEUCHTENSATZ

Ⓕ KIT LUMINEUX

Ⓖ LIGHTING SET

Ⓡ ОСВЕТИТЕЛЬНЫЙ КОМПЛЕКТ

Ⓟ ZESTAW OŚWIETLENIA

**Farmet**

**3012742**

Pos.	Part Number	Pcs.
13	m19295	1
40	m05566	30

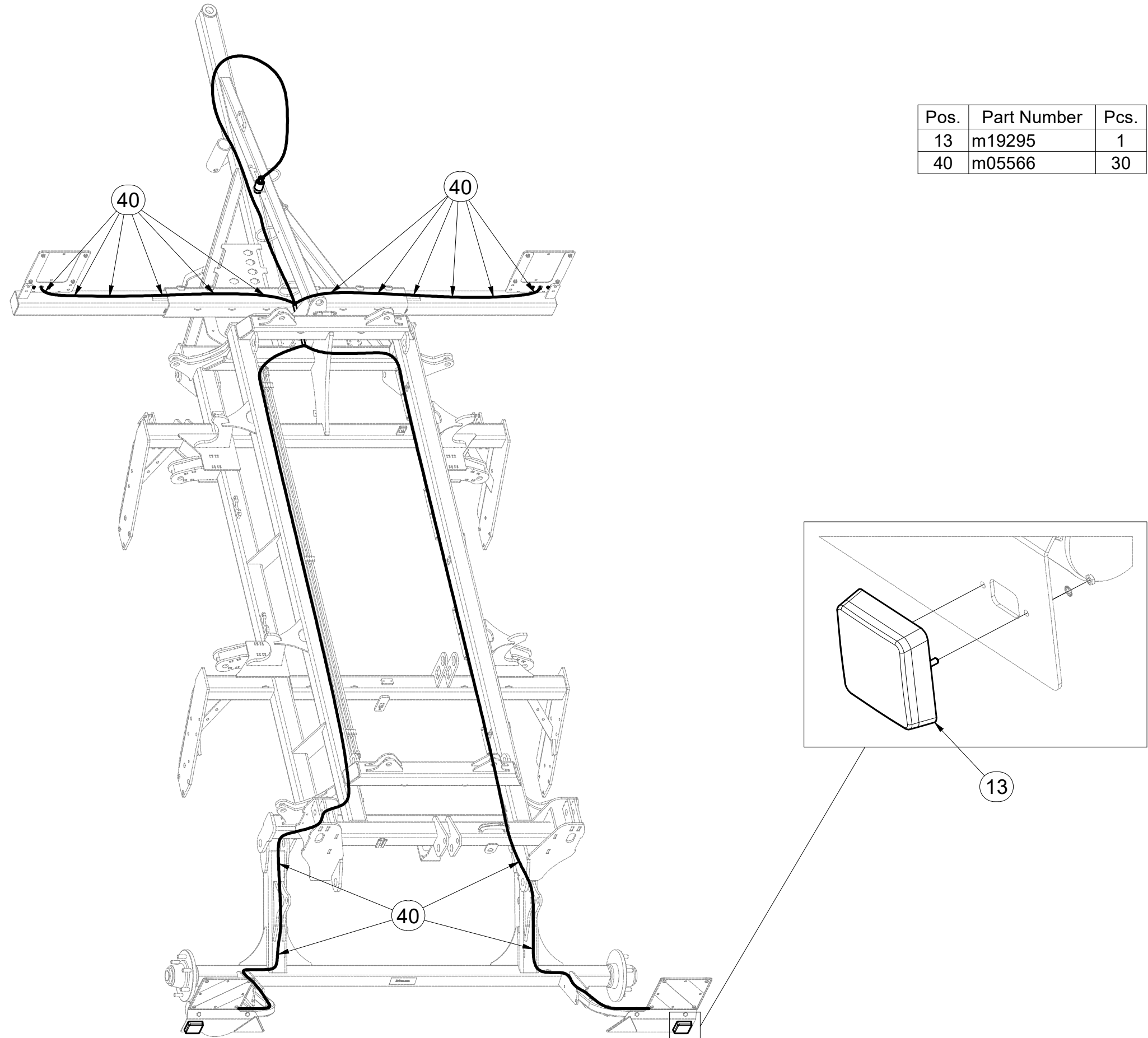

Ⓒ SVĚTELNÁ SADA

Ⓓ LEUCHTENSATZ

Ⓕ KIT LUMINEUX

Ⓖ LIGHTING SET

Ⓡ ОСВЕТИТЕЛЬНЫЙ КОМПЛЕКТ

Ⓢ ZESTAW OŚWIETLENIA



**3012742**

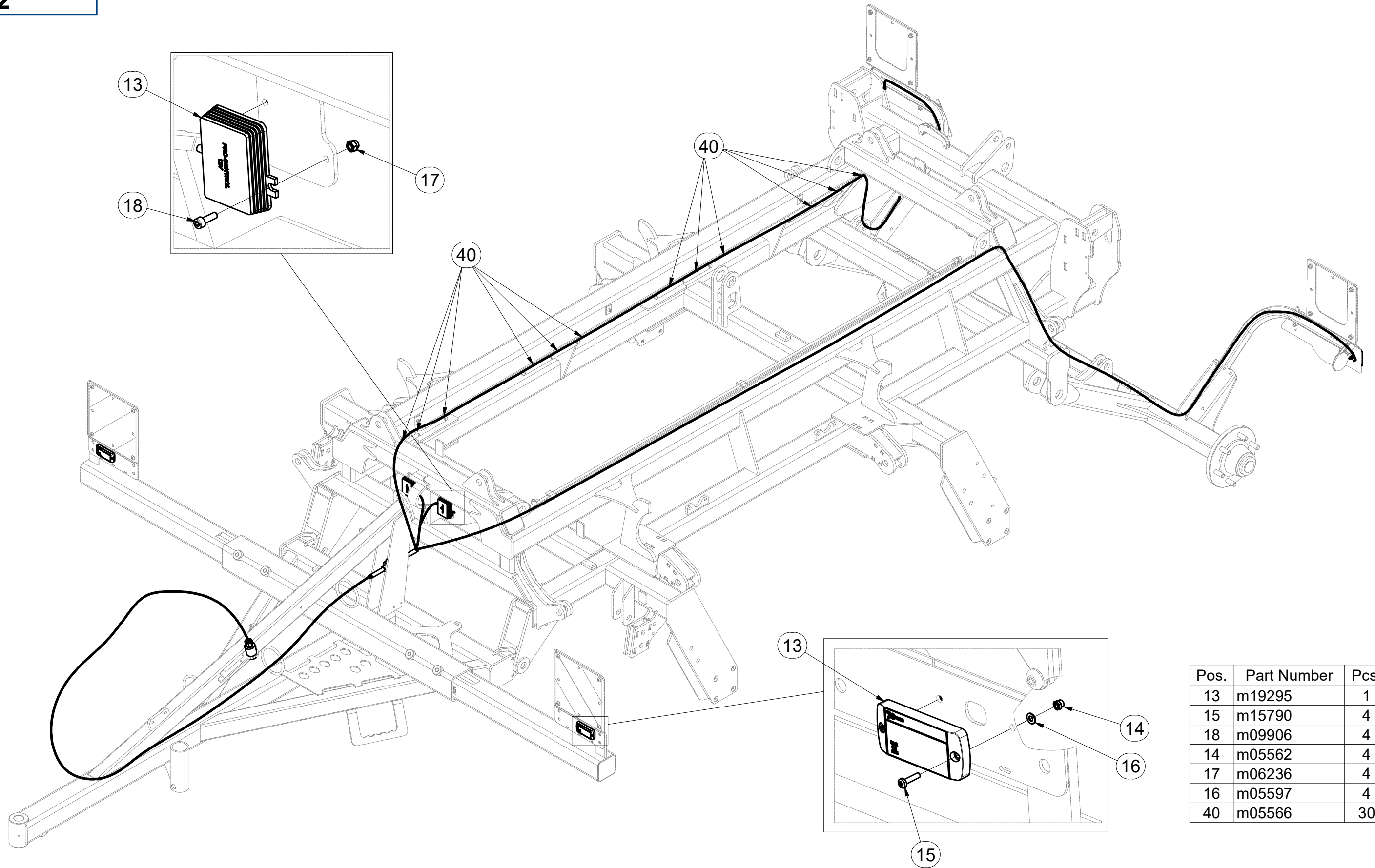

Pos.	Part Number	Pcs.
13	m19295	1
15	m15790	4
18	m09906	4
14	m05562	4
17	m06236	4
16	m05597	4
40	m05566	30

Ⓒ SVĚTELNÁ SADA

Ⓓ LEUCHTENSATZ

Ⓕ KIT LUMINEUX

**m19295**

Ⓖ LIGHTING SET

Ⓡ ОСВЕТИТЕЛЬНЫЙ КОМПЛЕКТ

Ⓢ ZESTAW OŚWIETLENIA

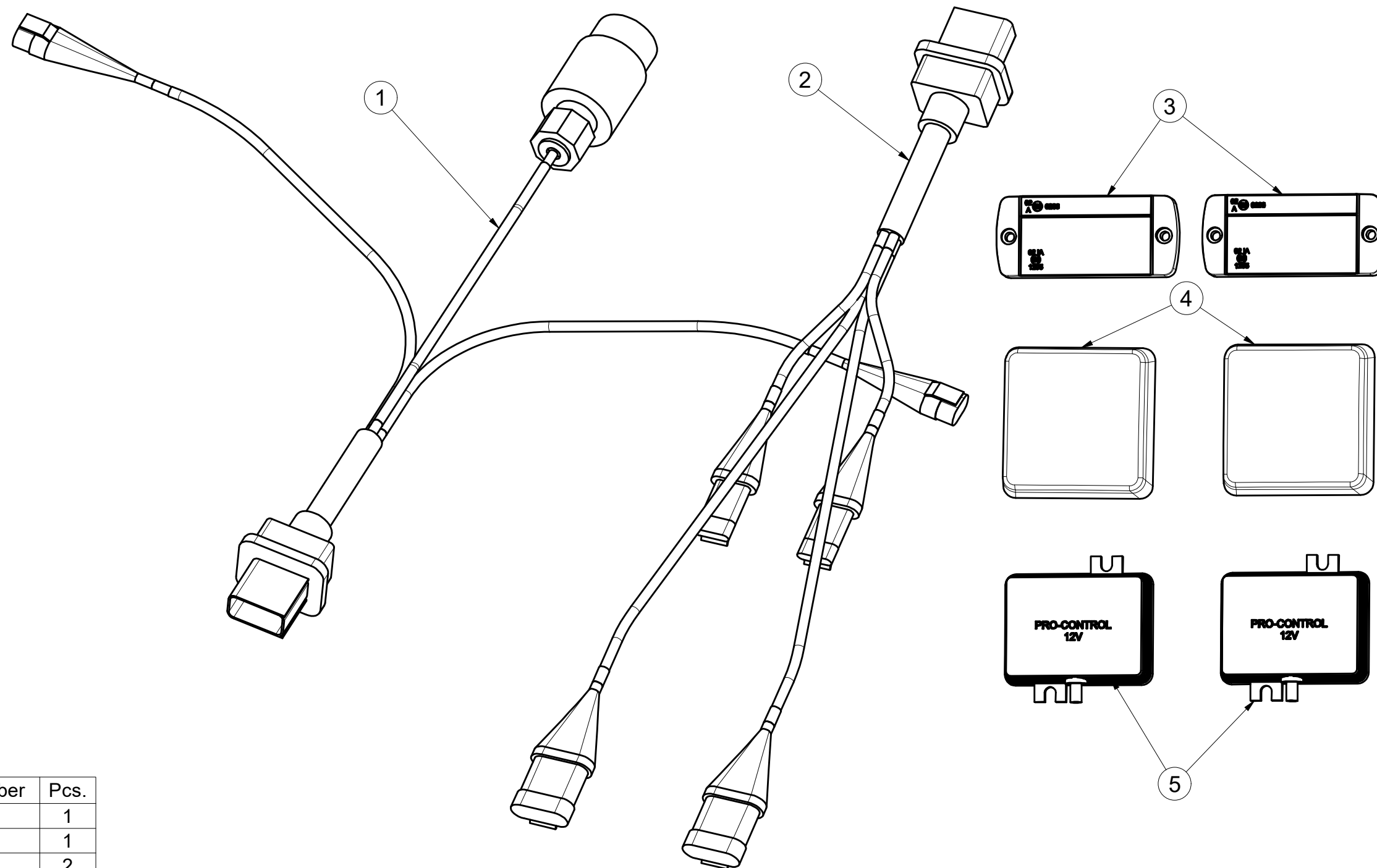

Pos.	Part Number	Pcs.
1	m14779	1
2	m14778	1
3	m14776	2
4	m19044	2
5	m14777	2



- Ⓒ UTAHOVACÍ MOMENTY ŠROUBŮ  
 Ⓓ ANZUGMOMENTE VON SCHRAUBEN  
 Ⓕ COUPLES DE SERRAGE DES VIS

- Ⓖ SCREW TIGHTENING TORQUE  
 Ⓔ МОМЕНТЫ ЗАЖАТИЯ БОЛТОВ  
 Ⓗ MOMENTY DOKRĘCANIA ŚRUB



P		5.8	8.8	10.9	12.9	Z	
D	R	Mu	Mu	Mu	Mu	DIN 7991	ISO 10642
mm	mm	Nm	Nm	Nm	Nm	Nm	Nm
M6	1	6	9	13	15	7,2	7,9
M8	1,25	14	22	32	38	17	19
M10	1,5	29	44	64	75	35	38
M12	1,75	49	76	111	130	58	65
M14	2	79	120	176	206	93	100
M16	2	123	188	276	323	144	158
M18	2,5	169	257	378	443	-	220
M20	2,5	239	365	536	628	-	310
M22	2,5	329	529	738	864	-	420
M24	3	413	629	924	1082	-	530
M27	3	613	934	1372	1606	-	-
M30	3,5	832	1267	1862	2179	-	-
M33	3,5	1130	1723	2530	2961	-	-
M36	4	1451	2210	3246	3799	-	-
M39	4	1885	2872	4217	4936	-	-
M42	4,5	2322	3538	5196	6080	-	-
M45	4,5	2909	4433	6511	7619	-	-
M48	5	3513	535	7862	9200	-	-
M52	5	4524	6895	10123	11849	-	-
M56	5,5	5636	8589	12614	14761	-	-

- Mu - Ⓒ UTAHOVACÍ MOMENT  
 Ⓓ ANZUGMOMENTE  
 Ⓕ COUPLE DE SERRAGE  
 Ⓖ TIGHTENING TORQUE  
 Ⓔ МОМЕНТ ЗАЖАТИЯ  
 Ⓗ MOMENT DOKRĘCANIA
- D - Ⓒ JMENOVITÝ PRŮMĚR  
 Ⓓ NENNDURCHMESSER  
 Ⓕ DIAMETRE NOMINAL  
 Ⓖ NOMINAL DIAMETER  
 Ⓔ НОМИНАЛЬНЫЙ ДИАМЕТР  
 Ⓗ ŚREDNICA NOMINALNA
- R - Ⓒ ROZTEČ ZÁVITU - STOUPÁNÍ  
 Ⓓ GEWINDESTEIFUNG  
 Ⓕ PAS DE FILET - PAS  
 Ⓖ SCREW PITCH – LEAD  
 Ⓔ ШАГ РЕЗЬБЫ  
 Ⓗ ROZSTAW GWINTU - SKOKI
- P - Ⓒ PEVNOST  
 Ⓓ FESTIGKEIT  
 Ⓕ RÉSISTANCE  
 Ⓖ STRENGTH  
 Ⓔ ПРОЧНОСТЬ  
 Ⓗ WYTRZYMA OŚĆ
- Z - Ⓒ ZÁPUSTNÉ ŠROUBY  
 Ⓓ SENKKOPFSCHRAUBEN  
 Ⓕ VIS A TETE FRAISEE  
 Ⓖ COUNTERSUNK SCREWS  
 Ⓔ БОЛТЫ С УТОПЛЕННОЙ ГОЛОВКОЙ  
 Ⓗ ŚRUBY Z ŁBEM STOŻKOWYM PŁASKIM

- Ⓒ Hodnoty momentů jsou poníženy o -10% oproti tabulkovým hodnotám. Šroubové spoje utahujte dle vyznačeného utahovacího momentu v dokumentaci. Pokud není utahovací moment v dokumentaci vyznačen, utahujte dle obecné tabulky. Pokud je v dokumentaci definován spoj šroubu a matice o různých pevnostech, vždy utahujte na moment komponenty nižší.
- Ⓓ Die Werte der Anzugsmomente sind um 10 % gegenüber den Tabellenwerten verringert. Ziehen Sie die Schraubverbindungen gemäß dem in der Dokumentation festgeschriebenen Anzugsmoment an. Sofern das Anzugsmoment nicht in der Dokumentation aufgeführt ist, ziehen Sie sie gemäß der allgemeinen Tabelle an. Wenn in der Dokumentation eine Verbindung von Schraube und Mutter mit verschiedene Festigkeiten definiert ist, wird immer mit dem Moment des Bauteils mit der geringeren Festigkeit angezogen.
- Ⓕ Les valeurs des couples de serrage sont baissées de 10% par rapport aux valeurs de tableau. Serrez les raccords à vis selon le couple de serrage indiqué dans les documents. Si le couple de serrage n'est pas indiqué dans les documents, serrez selon le tableau général. Si les documents définissent un assemblage par boulon de diverses résistances, serrez toujours au moment de la composante avec résistance inférieure.
- Ⓖ The torque values are reduced by 10% compared to the table values. Tighten the screw joints according to the tightening torque stated in the documentation. If the tightening torque is not stated in the documentation, tighten according to the general table. If there is a joint with a screw and a nut at different strengths in the documentation, always tighten to the torque of the component with lower strength.
- Ⓔ Значения моментов затяжки уменьшены на 10% по сравнению с данными в таблице. Резьбовые соединения зажимайте с установленным в документации моментом зажатия. Если в документации не указан момент зажатия, то зажимайте по действующей в общем таблице. Если в документации установлено соединение из болта и гайки различной прочности, всегда зажимайте с моментом для компонента с меньшей прочностью.
- Ⓗ Wartości momentów dokręcania są obniżone o 10% w stosunku do wartości z tabeli. Połączenia śrubowe należy dokręcać zgodnie z momentem obrotowym w dokumentacji. Jeśli w dokumentacji nie ma podanego momentu obrotowego, należy dokręcać zgodnie z ogólną tabelą. Jeśli w dokumentacji zdefiniowane jest połączenie ze śrubą nakrętką różnych wytrzymałościach, zawsze należy dokręcać zachowując moment dokręcania komponentu z niższą wytrzymałością.

- Ⓒ UTAHOVACÍ MOMENTY ŠROUBŮ  
 Ⓓ ANZUGMOMENTE VON SCHRAUBEN  
 Ⓕ COUPLES DE SERRAGE DES VIS

- Ⓖ SCREW TIGHTENING TORQUE  
 Ⓡ МОМЕНТЫ ЗАЖАТИЯ БОЛТОВ  
 Ⓟ MOMENTY DOKRĘCANIA ŚRUB



- Ⓒ **OBECNÝ PŘEDPIS UTAHOVÁNÍ ZAJIŠTĚNÍ ČEPOVÝCH SPOJŮ:**  
 Ⓓ **ALLGEMEINE VORSCHRIFT FÜR DAS ANZIEHEN VON BOLZENVERBINDUNGEN:**  
 Ⓕ **CONSIGNE GENERALE POUR LE SERRAGE DES ARTICULATIONS CYLINDRIQUES:**  
 Ⓖ **GENERAL INSTRUCTION FOR TIGHTENING THE SECURING OF PIN JOINTS:**  
 Ⓡ **ОБЩЕЕ ОПИСАНИЕ ЗАЖАТИЯ ПРЕДОХРАНЕНИЯ СОЕДИНЕНИЙ ПАЛЬЦАМИ:**  
 Ⓟ **OGÓLNE ZASADY DOKRĘCANIA ZABEZPIECZENIA POŁĄCZEŃ CZOPEM:**



**X**

M8, M10, M12

M14

**M**

09-15Nm

15-25Nm

- X - Ⓒ ROZMĚR ŠROUBU  
 Ⓓ SCHRAUBENGRÖSSE  
 Ⓕ DIMENSIONS DE LA VIS

- Ⓖ BOLT DIMENSION  
 Ⓡ РАЗМЕР БОЛТА  
 Ⓟ ROZMIAR ŚRUBY

- M - Ⓒ ORIENTAČNÍ MOMENT  
 Ⓓ ANZUGSMOMENT  
 Ⓕ COUPLE D'ORIENTATION

- Ⓖ ORIENTATION TORQUE  
 Ⓡ ОРИЕНТАЦИОННЫЙ МОМЕНТ  
 Ⓟ ORIENTACYJNY MOMENT

- Ⓒ Tyto spoje není nutné ověřovat kontrolou momentovým klíčem = stačí vizuálně kontrolovat sešroubování.  
 Ⓓ Diese Verbindungen müssen nicht mit einem Drehmomentschlüssel überprüft werden = es genügt, die Verschraubung visuell zu kontrollieren.  
 Ⓕ Il n'est pas nécessaire de contrôler le serrage à l'aide d'une clé dynamométrique = un contrôle visuel de l'assemblage suffit.  
 Ⓖ These joints do not have to be verified by checking with a torque wrench = visual inspection of bolting is sufficient.  
 Ⓡ Эти соединения не нужно контролировать динамометрическим ключом = достаточно визуально проверять прикручивание.  
 Ⓟ Nie trzeba sprawdzać tych połączeń kluczem dynamometrycznym = wystarczy wizualnie skontrolować dokręcenie.