

ⒸZ KATALOG NÁHRADNÍCH DÍLŮ ⒸB CATALOGUE OF SPARE PARTS ⒸD ERSATZTEILLISTE  
ⒸRU КАТАЛОГ ЗАПАСНЫХ ЧАСТЕЙ ⒸF CATALOGUE DES PIÈCES DE RECHANGE ⒸPL KATALOG CZĘŚCI ZAMIENNYCH

# SOFTER 8 PS

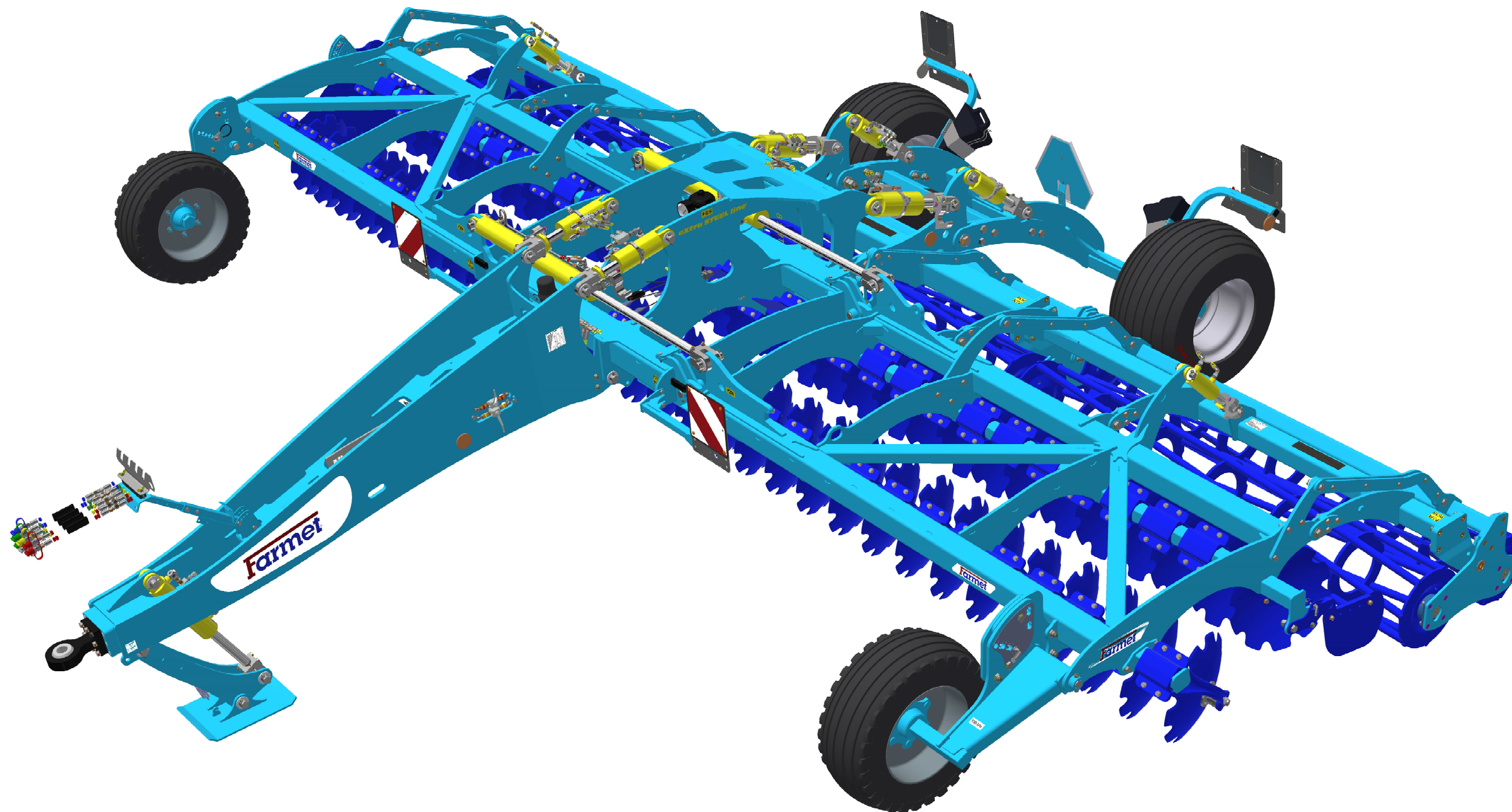

ⒸZ Platnost pro vrcholové | výrobní číslo stroje ⒸB Validity for the top | serial number of the machine  
ⒸD Gültigkeit für die Haupt- | Herstellungsnummer der Maschine ⒸRU Действительно для главного | заводского номера машины  
ⒸF Validité du numéro de référence | de série de la machine ⒸPL Obowiązuje dla numeru głównego | seryjnego maszyny

**9336140 | 2023/0595**

ⒸZ NAVIGACE STROJE

Ⓓ NAVIGATION DER MASCHINE

Ⓕ NAVIGATION DE LA MACHINE

ⒸB NAVIGATION OF THE MACHINE

ⒸU НАВИГАЦИЯ МАШИНЫ

ⒸL NAWIGACJA MASZYNY

**Farmet**

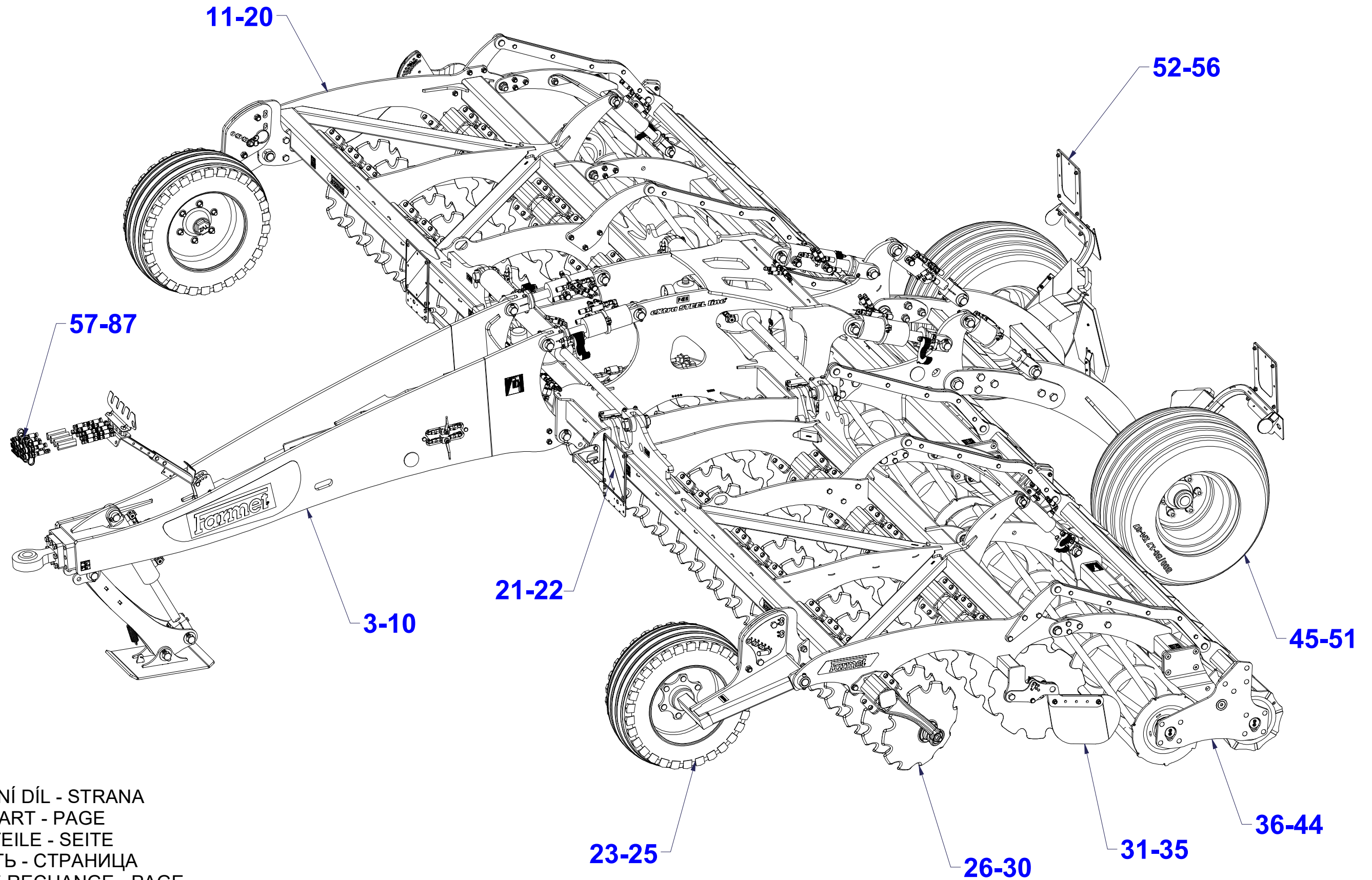

ⒸZ NÁHRADNÍ DÍL - STRANA

ⒸB SPARE PART - PAGE

Ⓓ ERSATZTEILE - SEITE

ⒸU ЗАПЧАСТЬ - СТРАНИЦА

Ⓕ PIÈCE DE RECHANGE - PAGE

ⒸL CZĘŚCI ZAMIENNE - STRONA

ⒸZ OJ MONT

Ⓓ DEICHSEL MONTIERT

Ⓕ TIMON MONTÉ

**3012701**

ⒼB MONT DRAWBAR

Ⓔ RU ДЫШЛО МОНТ.

ⒽL DYSZEL MONT

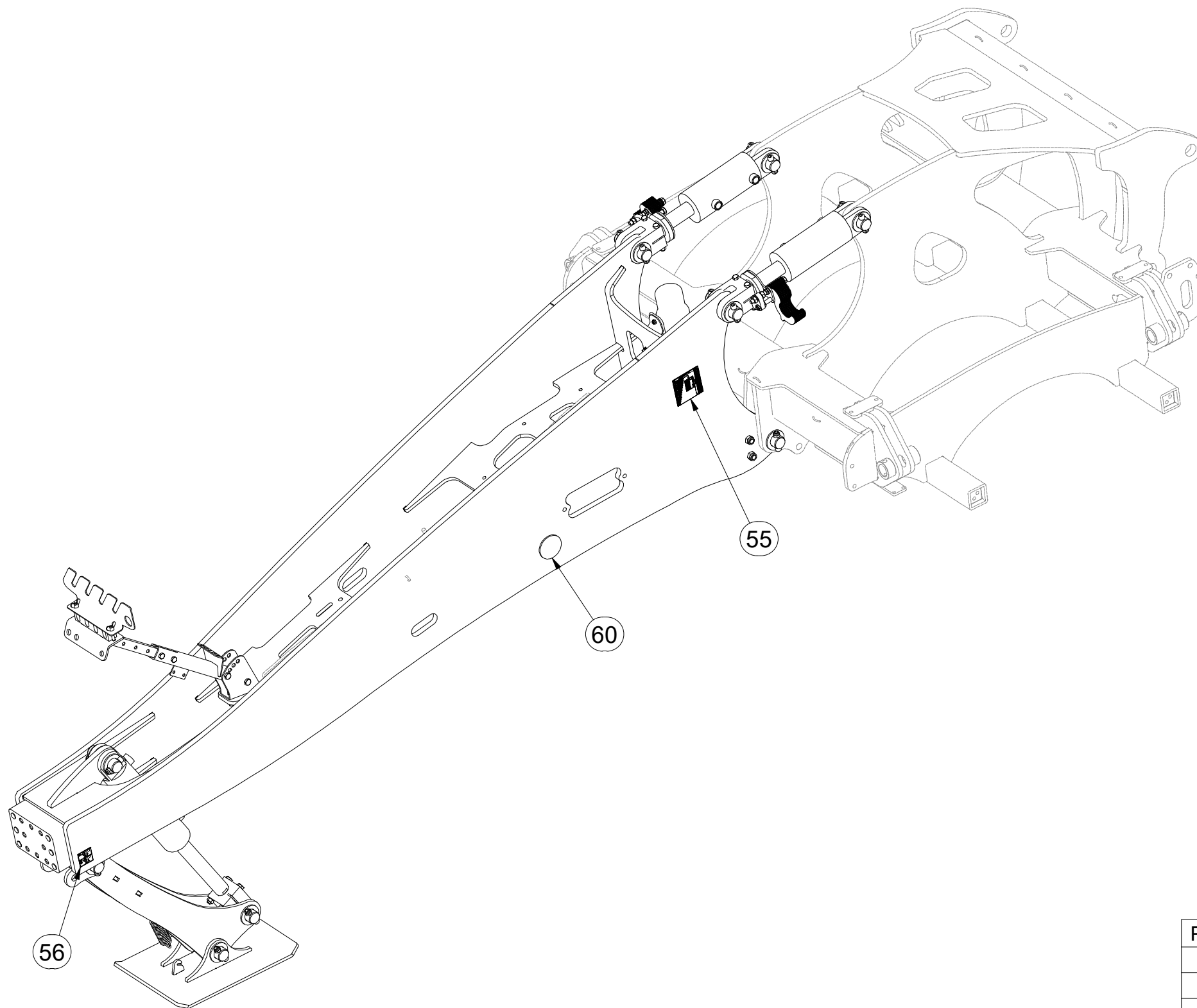

| Pos. | Part Number | Pcs. |
|------|-------------|------|
| 55   | m15025      | 1    |
| 56   | m16849      | 1    |
| 60   | m02579      | 2    |

ⒸZ OJ MONT

Ⓓ DEICHSEL MONTIERT

Ⓕ TIMON MONTÉ

**3012701**

ⒼB MONT DRAWBAR

ⒺD ДЫШЛО МОНТ.

ⒽL DYSZEL MONT

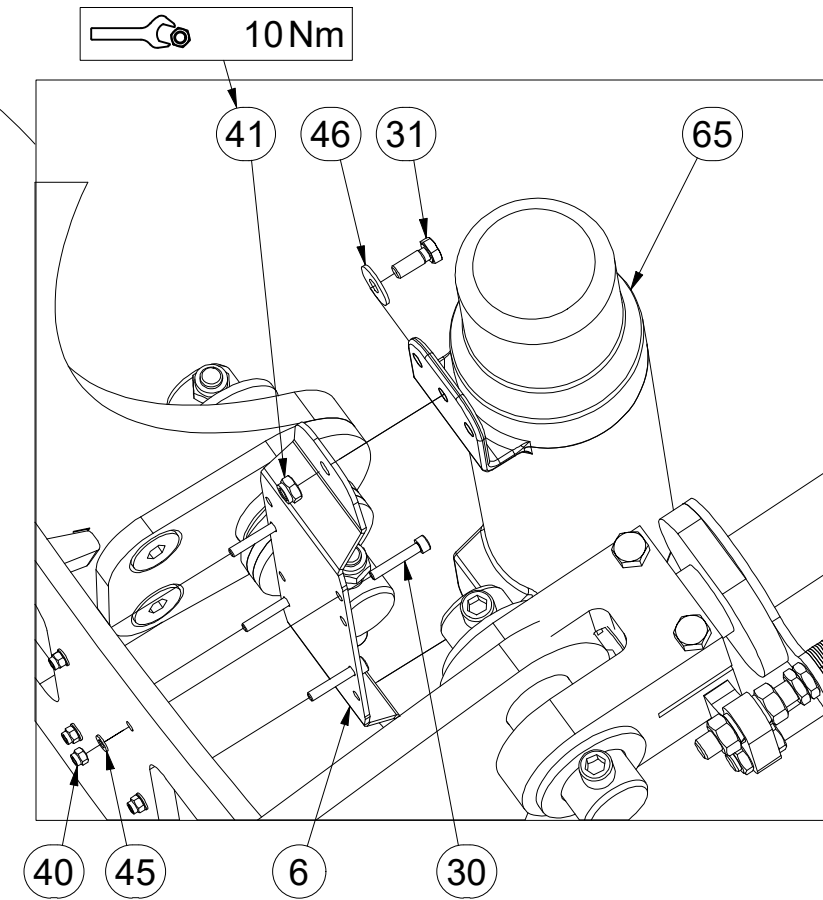
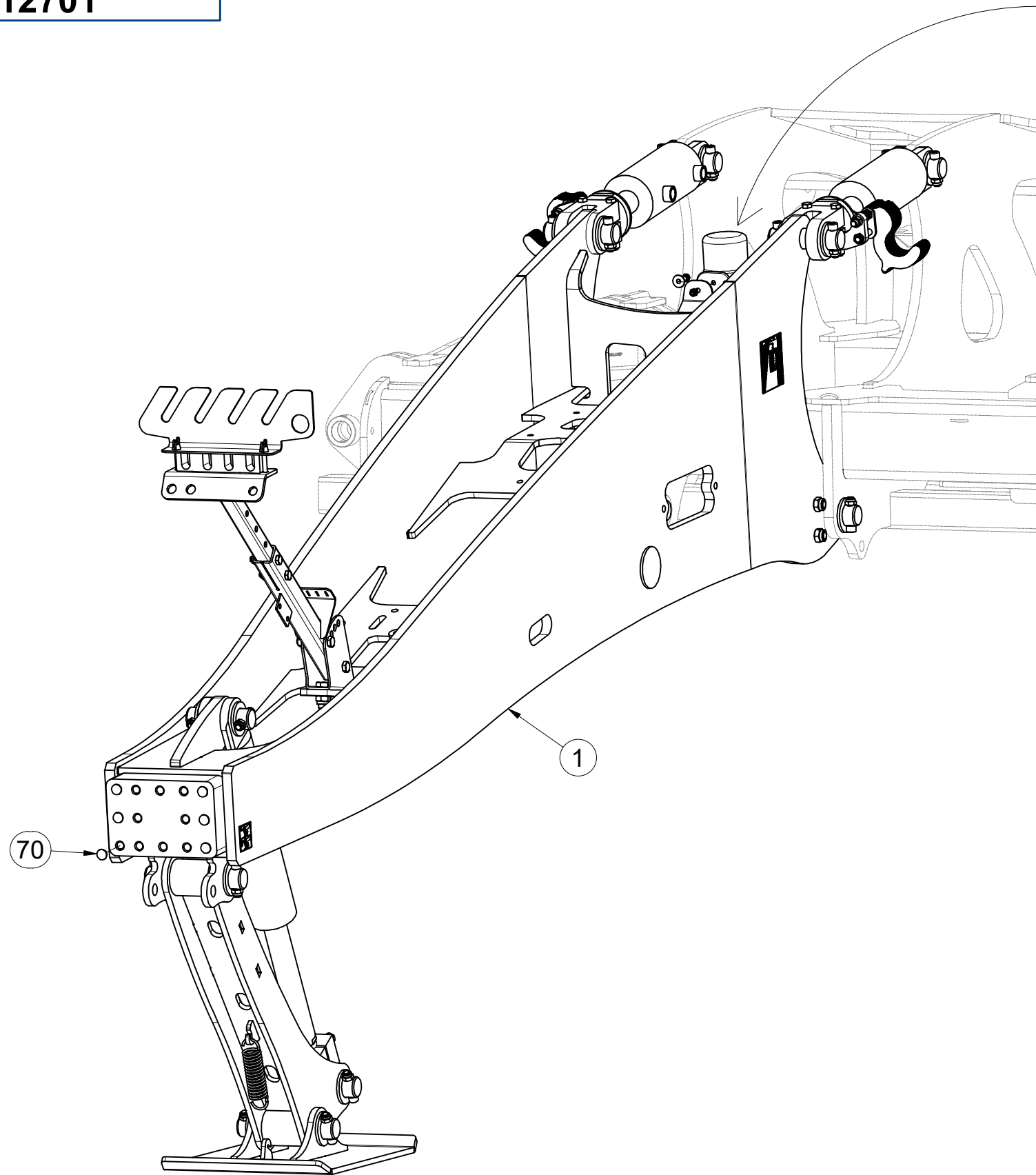

| Pos. | Part Number | Pcs. |
|------|-------------|------|
| 1    | 2001269     | 1    |
| 6    | 4017879     | 1    |
| 30   | m10029      | 4    |
| 31   | m01089      | 2    |
| 40   | m06236      | 4    |
| 41   | m04503      | 2    |
| 45   | m04164      | 4    |
| 46   | m07936      | 2    |
| 65   | m15900      | 1    |
| 70   | m12433      | 6    |

ⒸZ OJ MONT

Ⓓ DEICHSEL MONTIERT

Ⓕ TIMON MONTÉ

ⒸB MONT DRAWBAR

ⒸR ДЫШЛО МОНТ.

ⒸL DYSZEL MONT



**3012701**

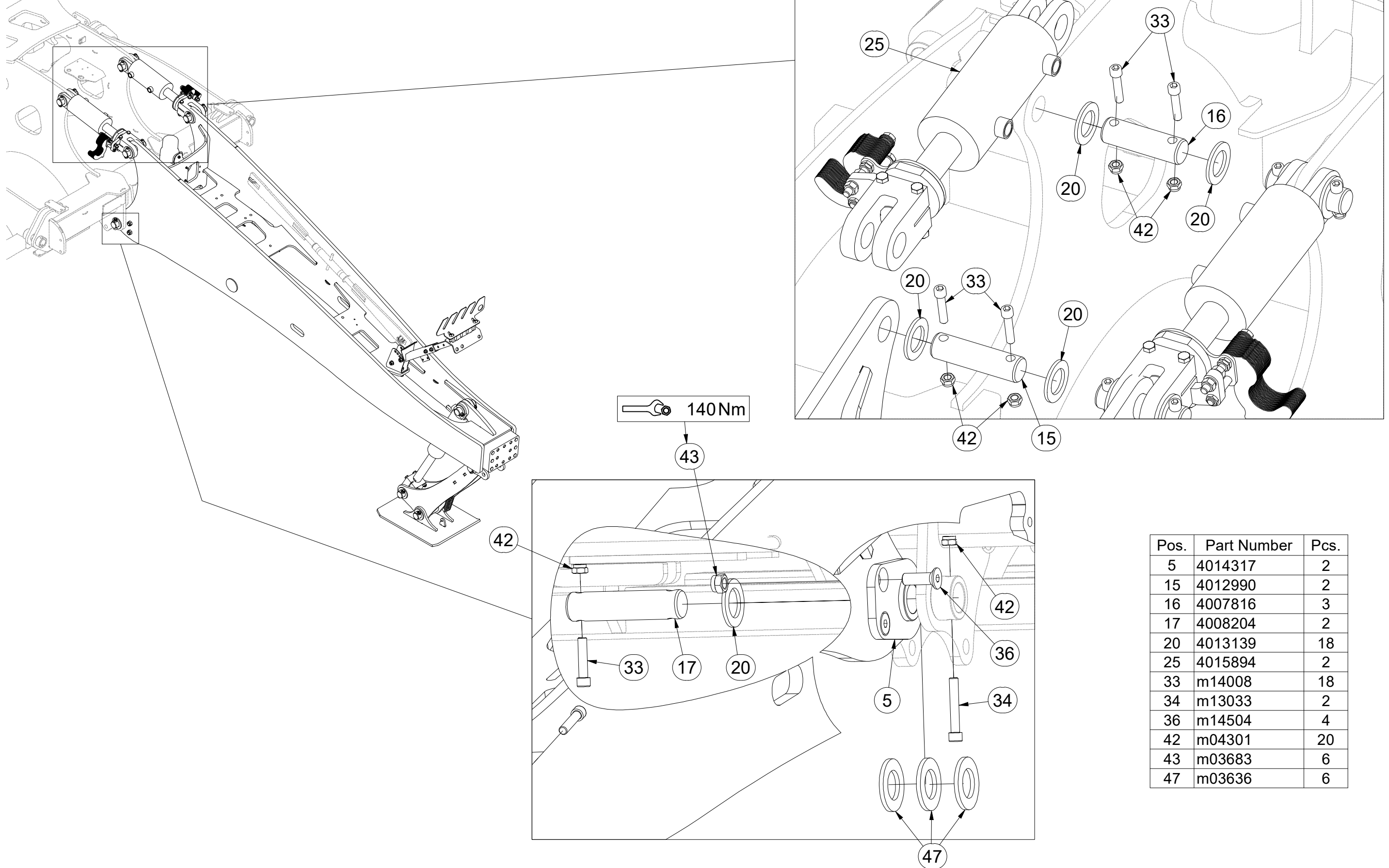

| Pos. | Part Number | Pcs. |
|------|-------------|------|
| 5    | 4014317     | 2    |
| 15   | 4012990     | 2    |
| 16   | 4007816     | 3    |
| 17   | 4008204     | 2    |
| 20   | 4013139     | 18   |
| 25   | 4015894     | 2    |
| 33   | m14008      | 18   |
| 34   | m13033      | 2    |
| 36   | m14504      | 4    |
| 42   | m04301      | 20   |
| 43   | m03683      | 6    |
| 47   | m03636      | 6    |

ⒸZ OJ MONT

Ⓓ DEICHSEL MONTIERT

Ⓕ TIMON MONTÉ

ⒼB MONT DRAWBAR

Ⓔ RU ДЫШЛО МОНТ.

ⒽL DYSZEL MONT



**3012701**

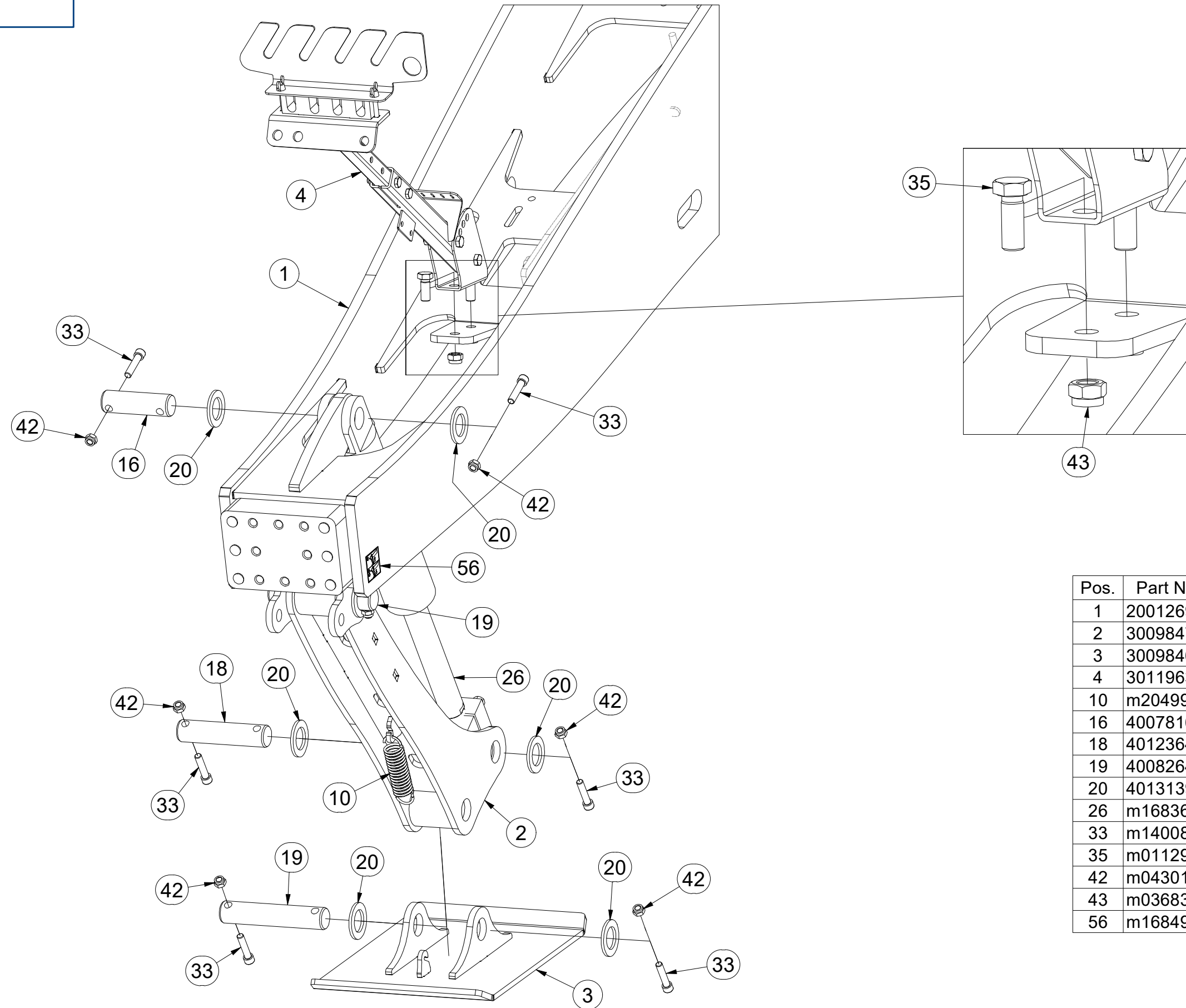

| Pos. | Part Number | Pcs. |
|------|-------------|------|
| 1    | 2001269     | 1    |
| 2    | 3009847     | 1    |
| 3    | 3009846     | 1    |
| 4    | 3011963     | 1    |
| 10   | m20499      | 1    |
| 16   | 4007816     | 3    |
| 18   | 4012364     | 1    |
| 19   | 4008264     | 2    |
| 20   | 4013139     | 18   |
| 26   | m16836      | 1    |
| 33   | m14008      | 18   |
| 35   | m01129      | 2    |
| 42   | m04301      | 20   |
| 43   | m03683      | 6    |
| 56   | m16849      | 1    |

CZ TELESKOPICKÝ DRŽÁK HADIC  
 D TELESKOPSCHLAUCHHALTER  
 F SUPPORT DE TUYAU TÉLESCOPIQUE

GB TELESCOPIC HOSE HOLDER  
 RU ТЕЛЕСКОПИЧЕСКИЙ ДЕРЖАТЕЛЬ ШЛАНГА  
 PL TELESKOPOWY UCHWYT NA WAŻ



**3011963**

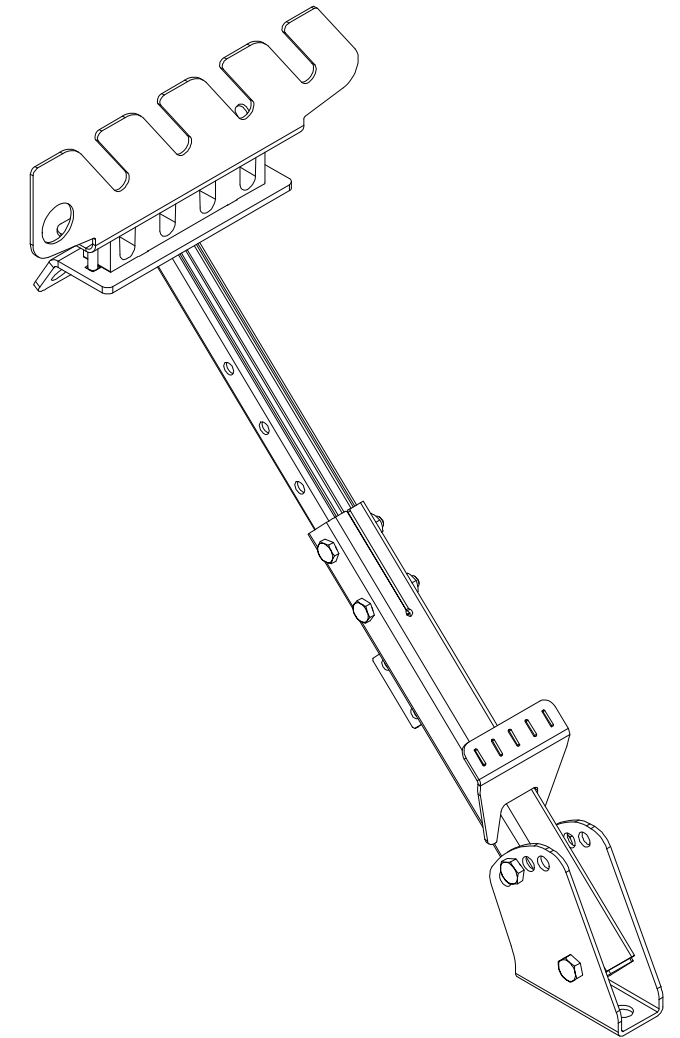
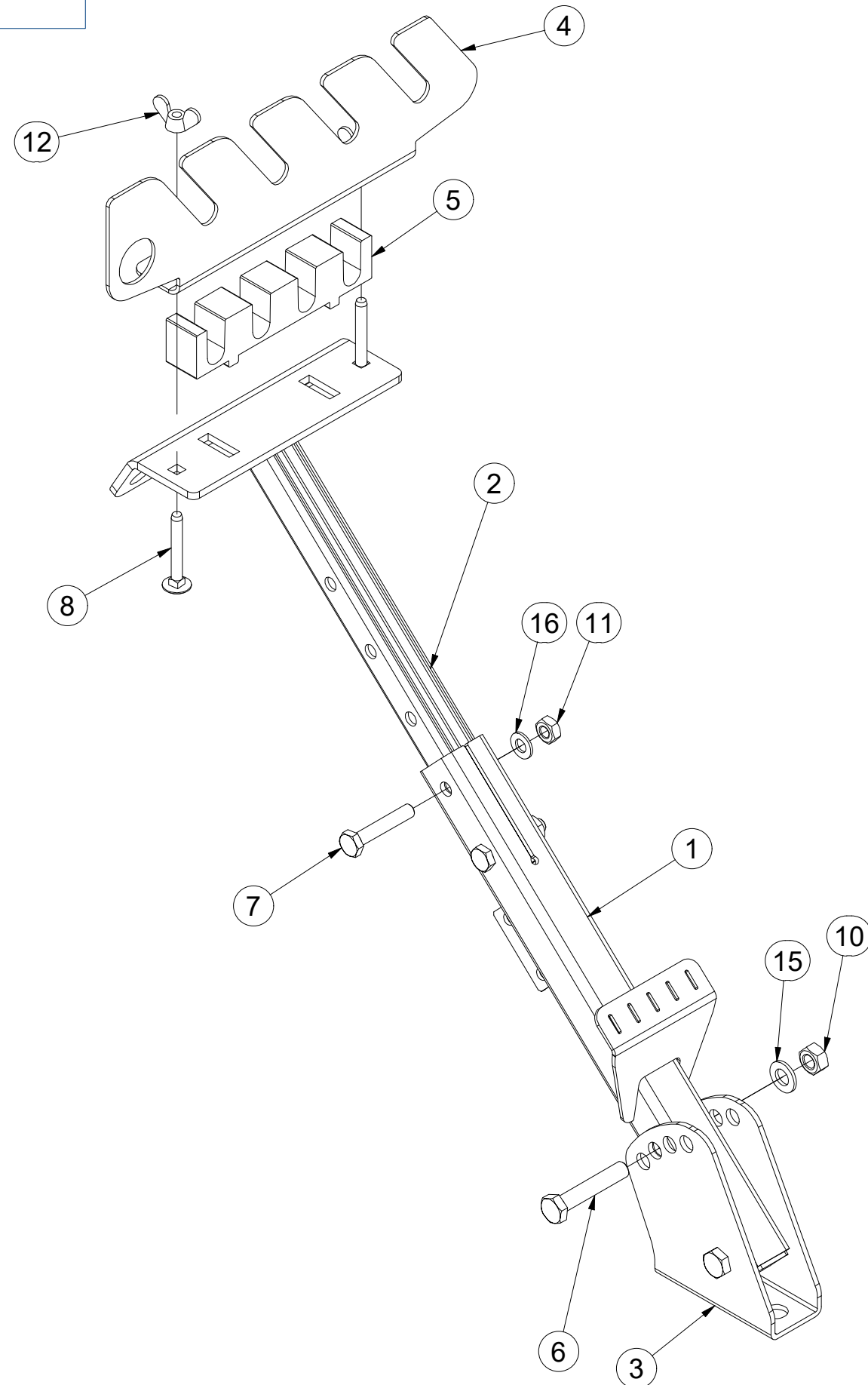

| Pos. | Part Number | Pcs. |
|------|-------------|------|
| 1    | 3011662     | 1    |
| 2    | 3011689     | 1    |
| 3    | 3011659     | 1    |
| 4    | 4023572     | 1    |
| 5    | m22642      | 1    |
| 6    | m05898      | 2    |
| 7    | m06253      | 2    |
| 8    | m09247      | 2    |
| 10   | m01305      | 2    |
| 11   | m01299      | 2    |
| 12   | m01316      | 2    |
| 15   | m01214      | 2    |
| 16   | m01209      | 2    |

ⒸZ TÁHLO  
Ⓓ STANGE  
Ⓕ TIGE DE TRACTION

ⒼB DRAWBAR  
Ⓔ RU ТЯГА  
ⒼL PRĘT



**VZ00006988**

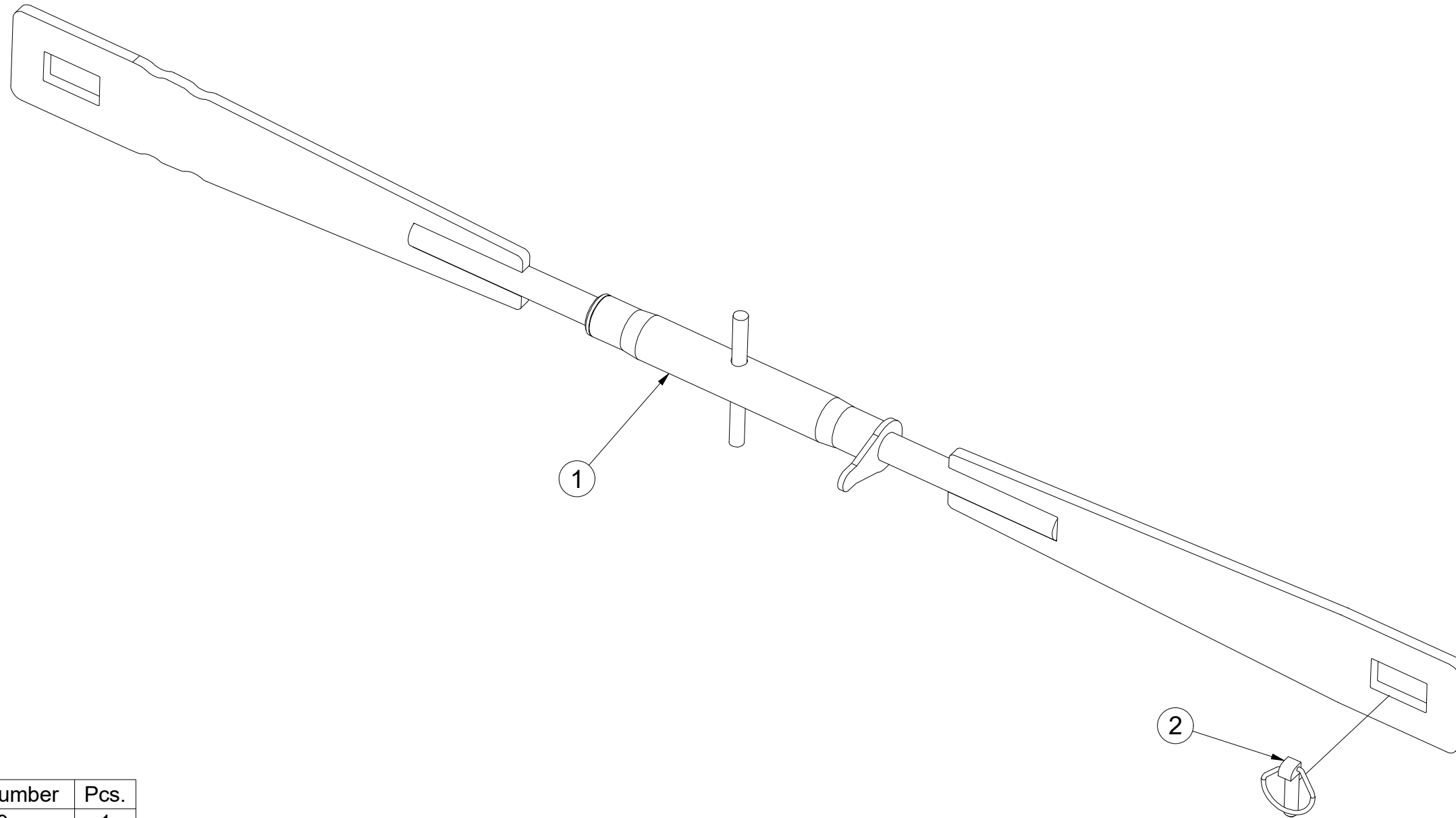

| Pos. | Part Number | Pcs. |
|------|-------------|------|
| 1    | 4009359     | 1    |
| 2    | m02505      | 1    |



Ⓒ SPOJOVACÍ TÁHLO  
Ⓓ VERBINDUNGSSTANGE  
Ⓕ TIGE DE RACCORDEMENT

Ⓖ CONNECTING ROD  
Ⓡ СОЕДИНИТЕЛЬНАЯ ТЯГА  
Ⓟ KORBOWÓD

**Farmet**

**4009359**

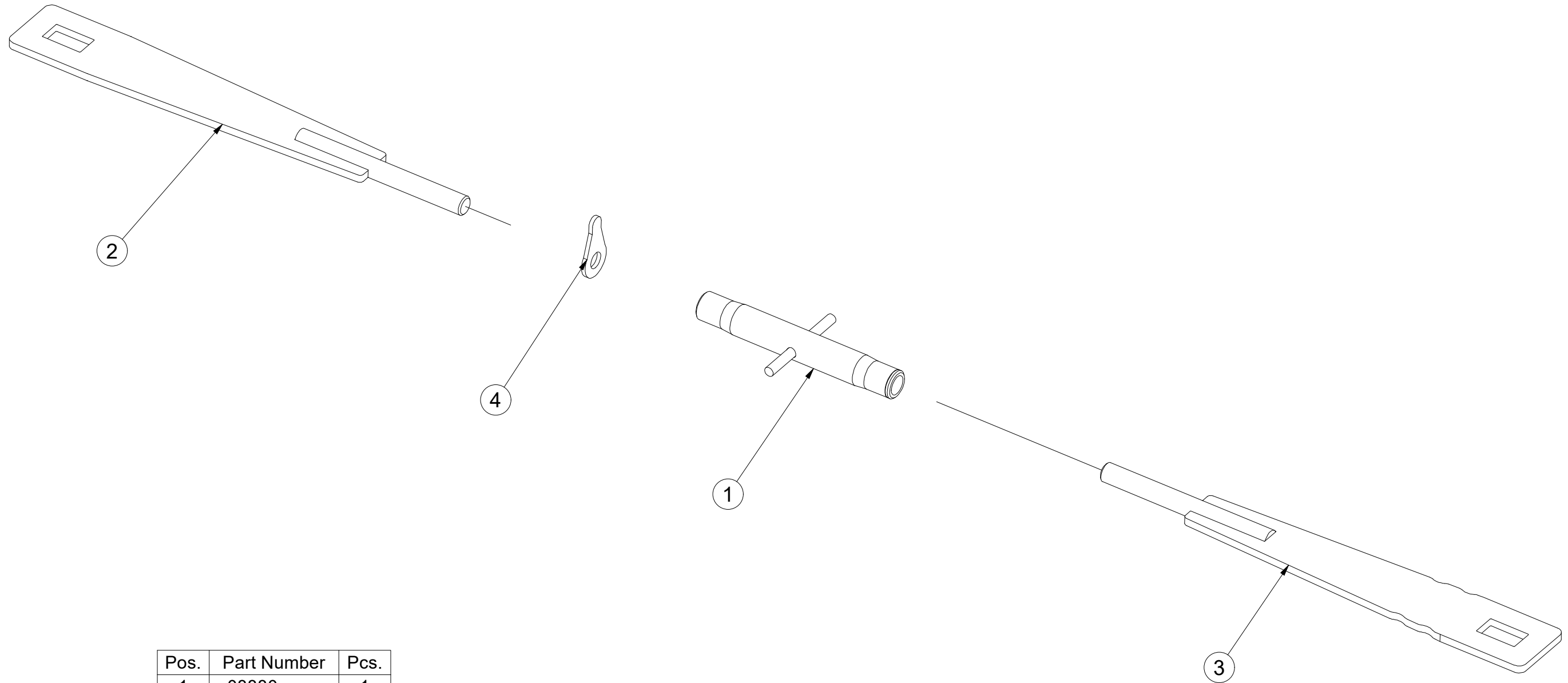

| Pos. | Part Number | Pcs. |
|------|-------------|------|
| 1    | m08880      | 1    |
| 2    | 4009356     | 1    |
| 3    | 4009360     | 1    |
| 4    | m08881      | 1    |

Ⓒ SADA TAŽNÉHO OKA

Ⓓ ZUGÖSESATZ

Ⓕ KIT DE L'ŒILLET DE TRACTION

Ⓖ TOWING LUG SET

Ⓡ КОМПЛЕКТ ТЯГОВОГО ДЫШЛА

Ⓟ ZESTAW UCHA HOLOWNICZEGO



**4013529**

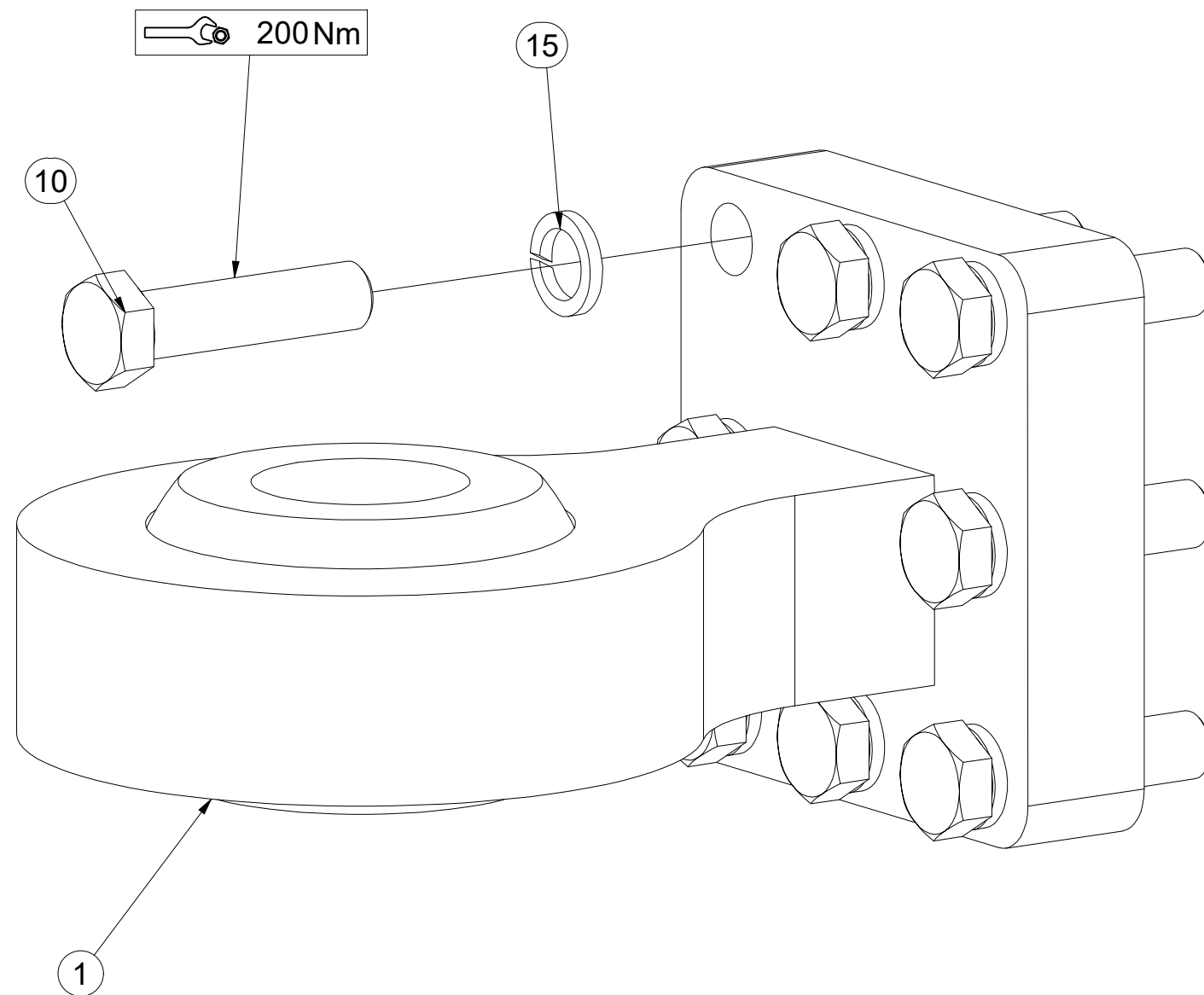

| Pos. | Part Number | Pcs. |
|------|-------------|------|
| 1    | m13263      | 1    |
| 10   | m21355      | 8    |
| 15   | m02157      | 8    |

Ⓒ ZÁKLAD STROJE

Ⓓ UNTERBAU DER MASCHINE

Ⓕ BÂTI DE LA MACHINE

**VZ00030336**

Ⓖ FOOTING OF THE MACHINE

Ⓡ ОСНОВАНИЕ МАШИНЫ

Ⓢ PODSTAWA MASZINY

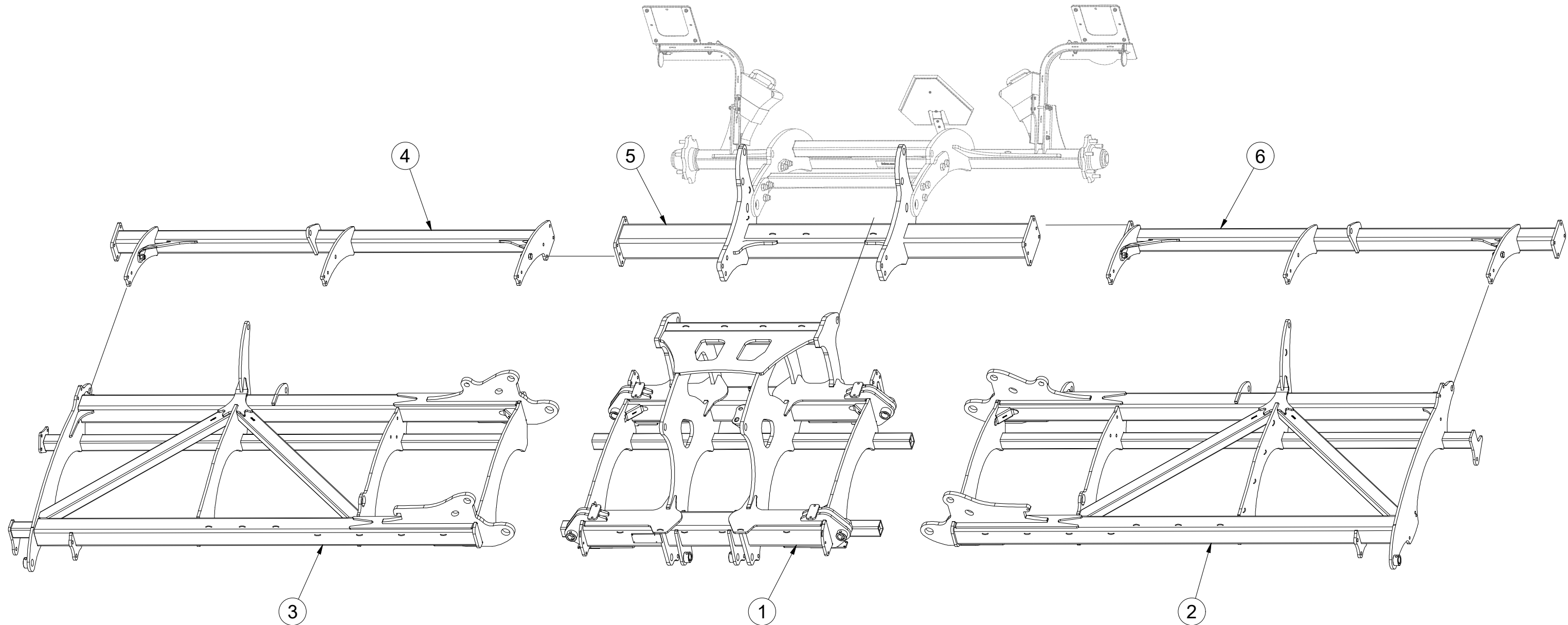

| Pos. | Part Number | Pcs. |
|------|-------------|------|
| 1    | 1000587     | 1    |
| 2    | 2001276     | 1    |
| 3    | VZ00030337  | 1    |
| 4    | 3008715     | 1    |
| 5    | 3008716     | 1    |
| 6    | 3008714     | 1    |

Ⓒ ZÁKLAD STROJE

Ⓓ UNTERBAU DER MASCHINE

Ⓕ BÂTI DE LA MACHINE

Ⓖ FOOTING OF THE MACHINE

Ⓡ ОСНОВАНИЕ МАШИНЫ

Ⓢ PODSTAWA MASZYNY



**VZ00030336**

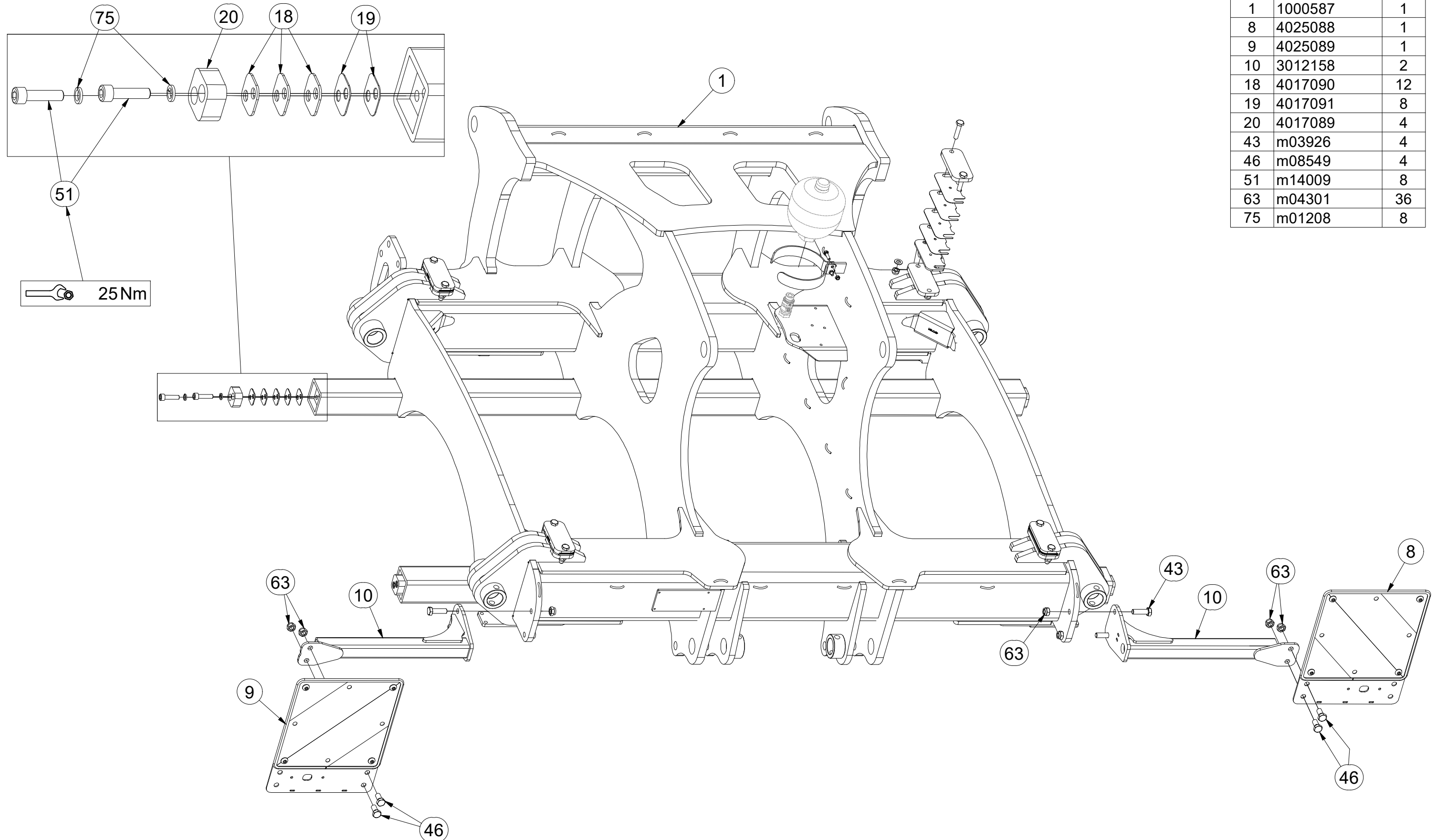

| Pos. | Part Number | Pcs. |
|------|-------------|------|
| 1    | 1000587     | 1    |
| 8    | 4025088     | 1    |
| 9    | 4025089     | 1    |
| 10   | 3012158     | 2    |
| 18   | 4017090     | 12   |
| 19   | 4017091     | 8    |
| 20   | 4017089     | 4    |
| 43   | m03926      | 4    |
| 46   | m08549      | 4    |
| 51   | m14009      | 8    |
| 63   | m04301      | 36   |
| 75   | m01208      | 8    |

Ⓒ ZÁKLAD STROJE

Ⓓ UNTERBAU DER MASCHINE

Ⓕ BÂTI DE LA MACHINE

Ⓖ FOOTING OF THE MACHINE

Ⓡ ОСНОВАНИЕ МАШИНЫ

Ⓢ PODSTAWA MASZYNY



**VZ00030336**

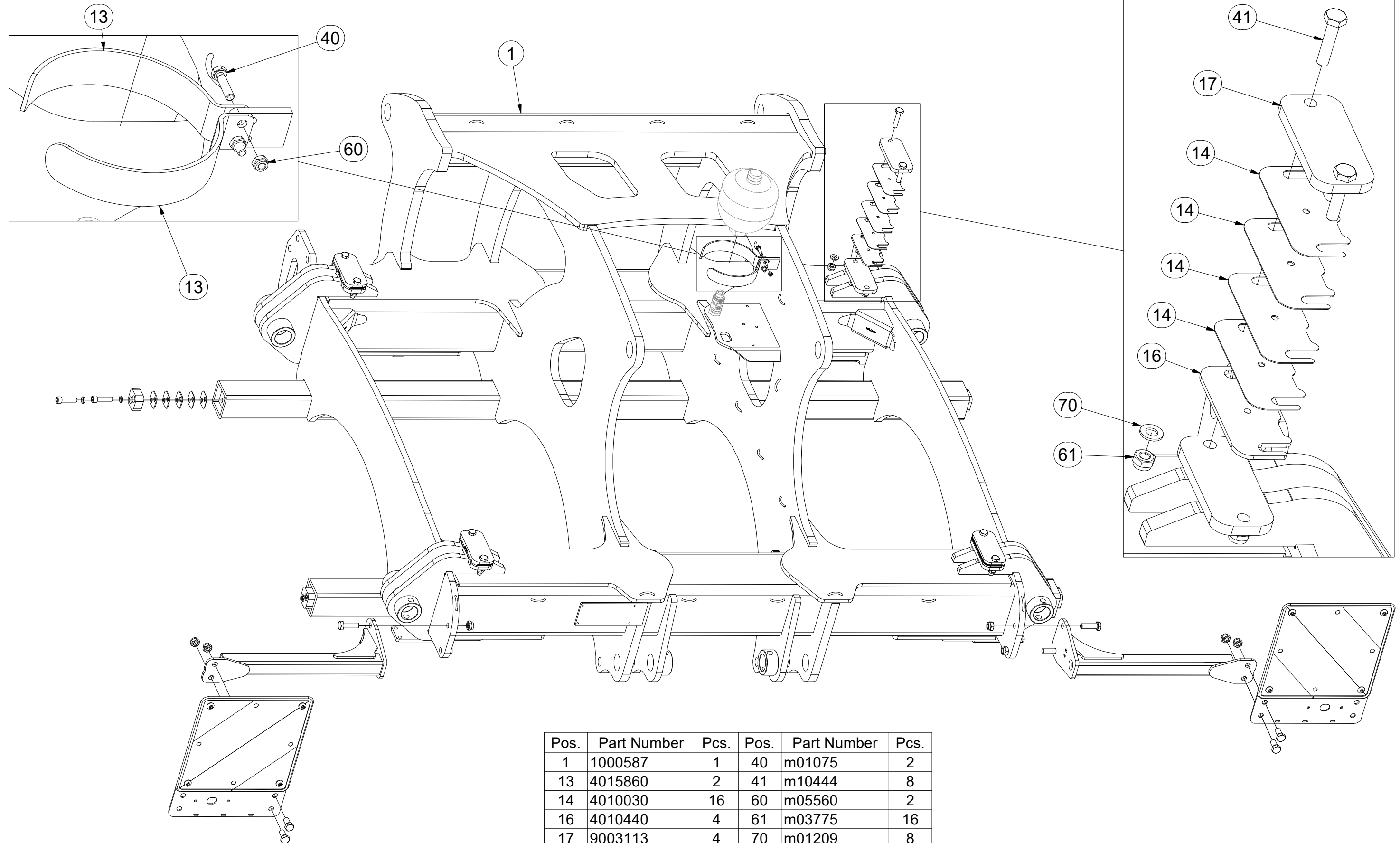

| Pos. | Part Number | Pcs. | Pos. | Part Number | Pcs. |
|------|-------------|------|------|-------------|------|
| 1    | 1000587     | 1    | 40   | m01075      | 2    |
| 13   | 4015860     | 2    | 41   | m10444      | 8    |
| 14   | 4010030     | 16   | 60   | m05560      | 2    |
| 16   | 4010440     | 4    | 61   | m03775      | 16   |
| 17   | 9003113     | 4    | 70   | m01209      | 8    |

☉ ZÁKLAD STROJE

Ⓧ UNTERBAU DER MASCHINE

Ⓧ BÂTI DE LA MACHINE

**VZ00030336**

Ⓧ FOOTING OF THE MACHINE

Ⓧ ОСНОВАНИЕ МАШИНЫ

Ⓧ PODSTAWA MASZYNY

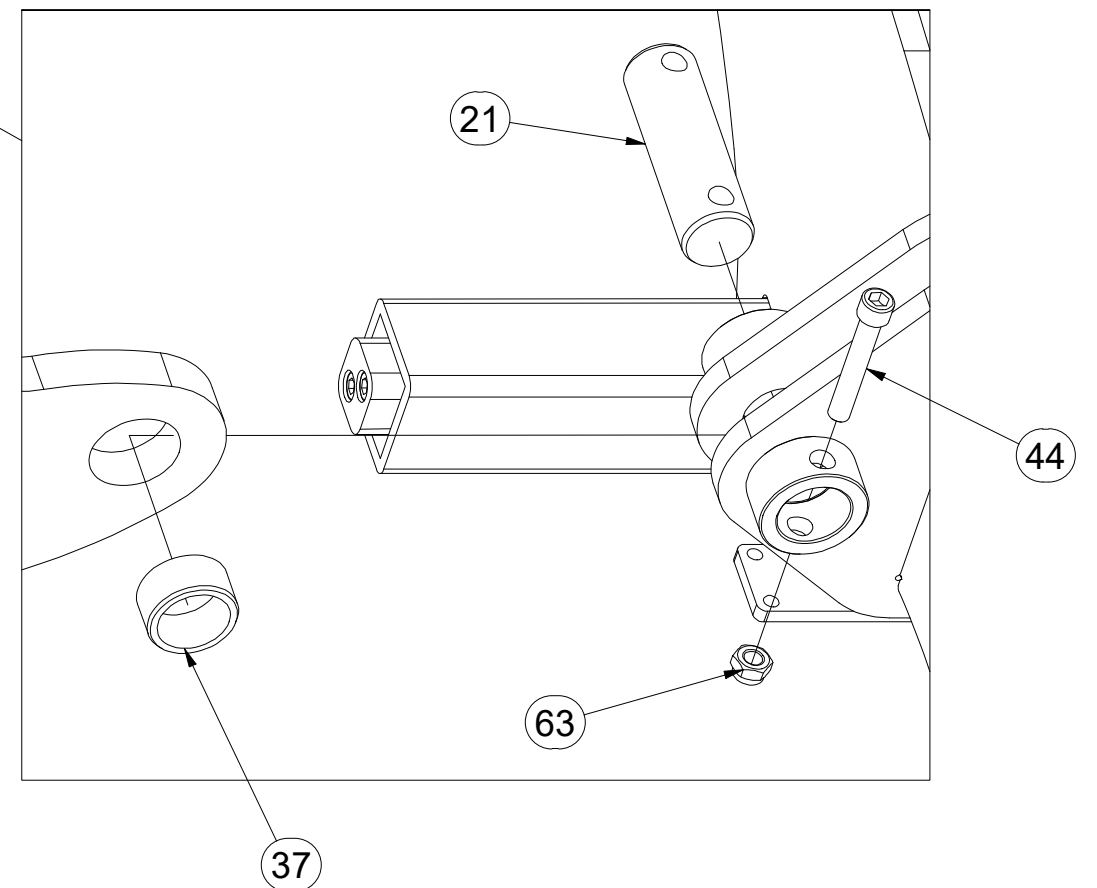
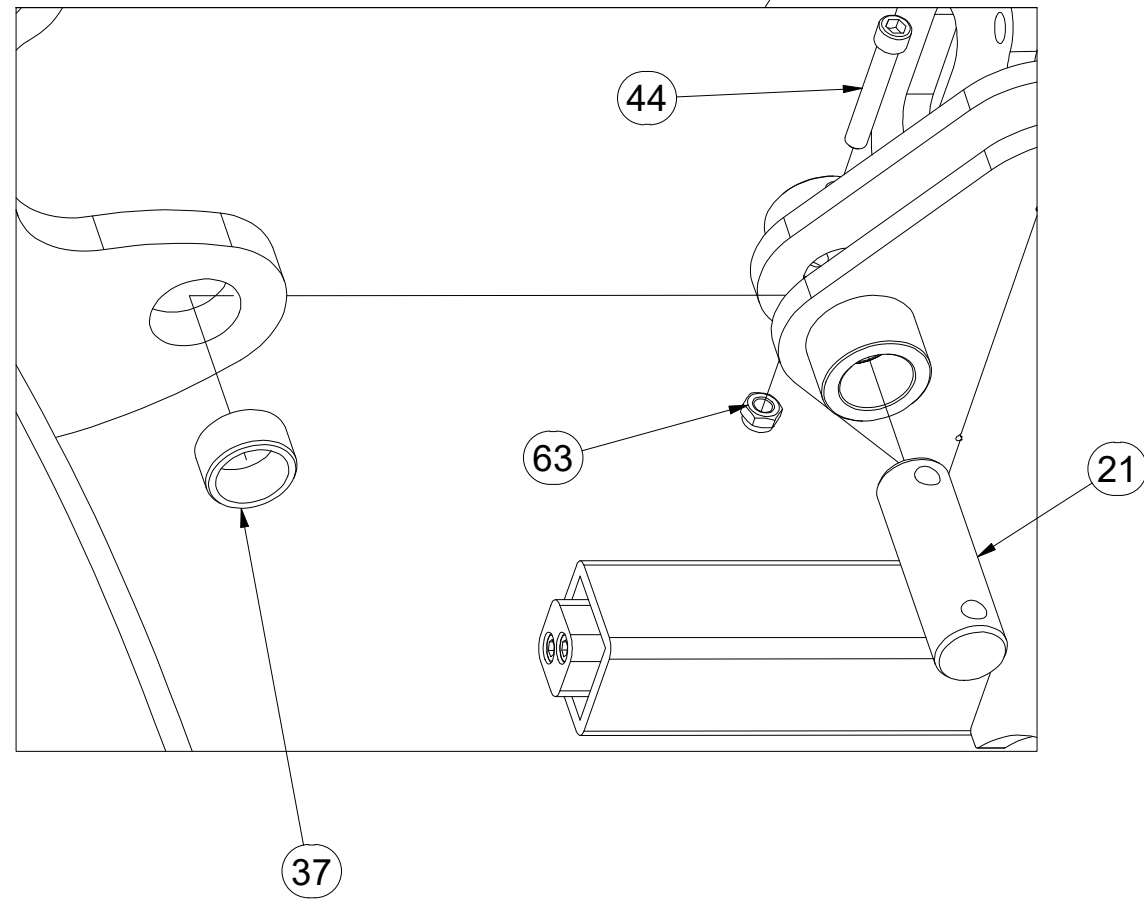
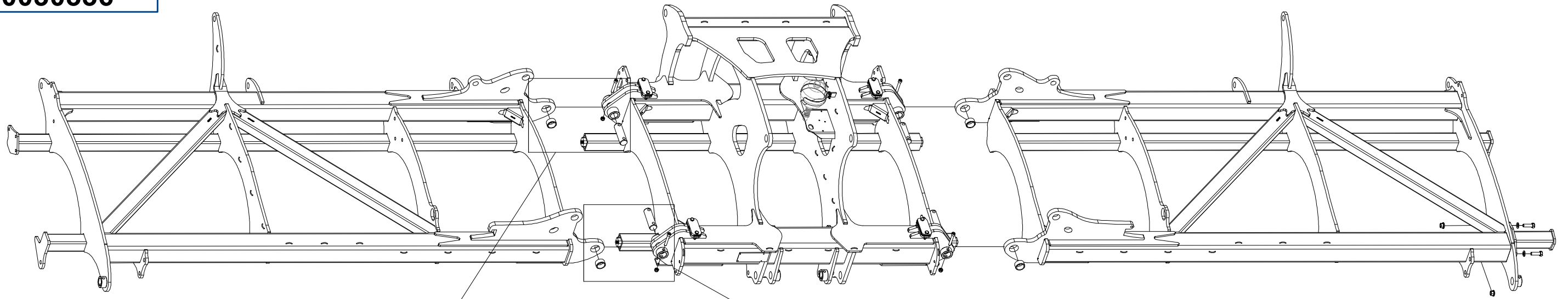

| Pos. | Part Number | Pcs. |
|------|-------------|------|
| 21   | 4007816     | 8    |
| 37   | m15002      | 4    |
| 44   | m13033      | 4    |
| 63   | m04301      | 36   |

Ⓒ ZÁKLAD STROJE

Ⓓ UNTERBAU DER MASCHINE

Ⓕ BÂTI DE LA MACHINE

**VZ00030336**

Ⓖ FOOTING OF THE MACHINE

Ⓡ ОСНОВАНИЕ МАШИНЫ

Ⓢ PODSTAWA MASZYNY

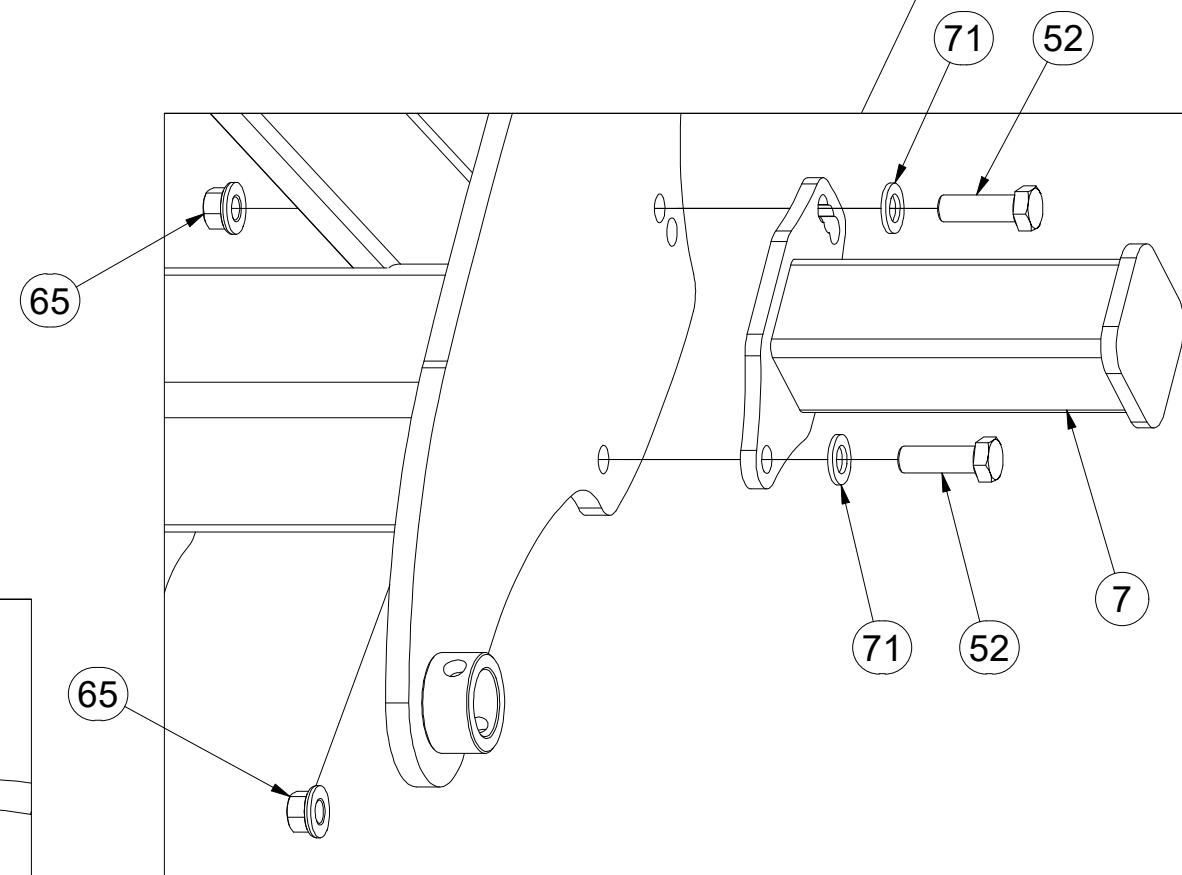
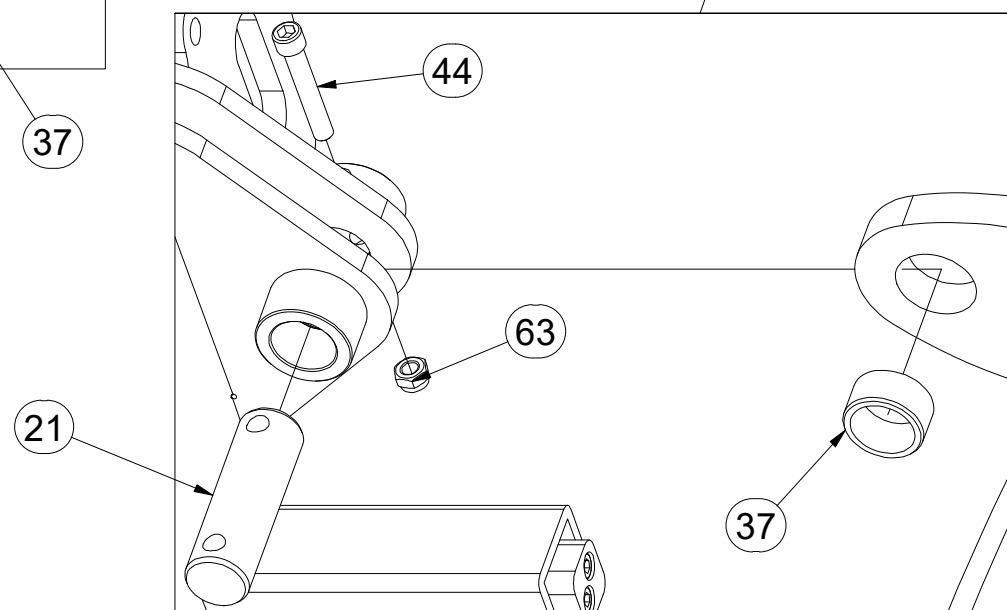
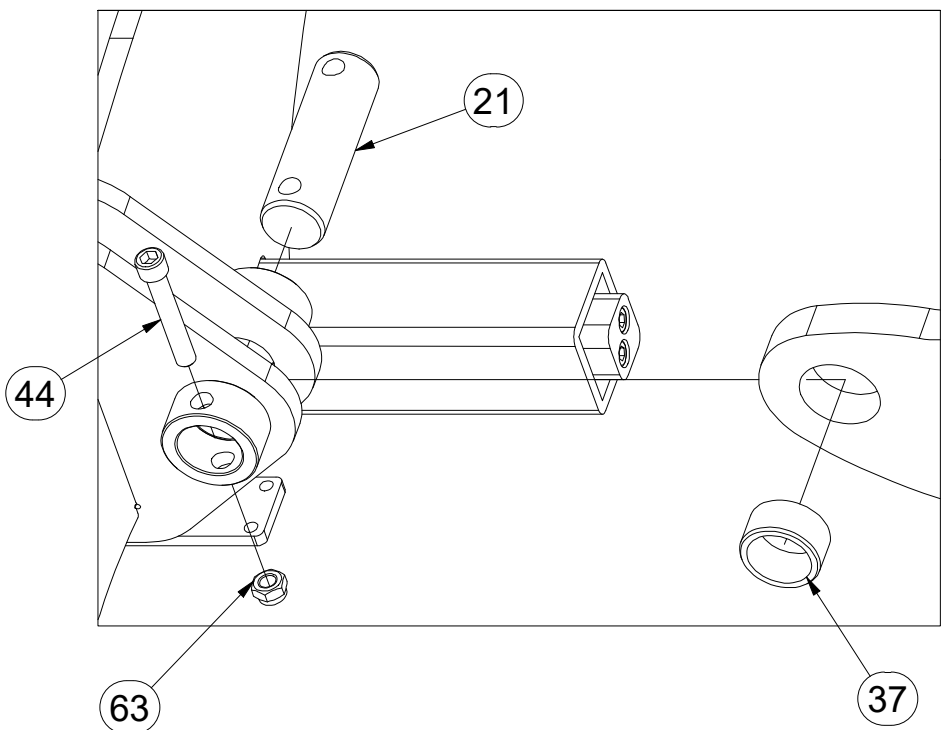
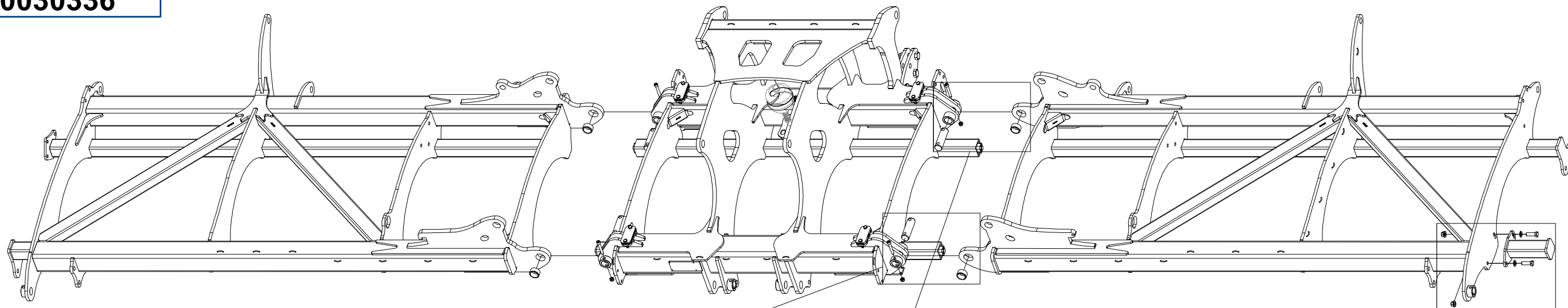

| Pos. | Part Number | Pcs. |
|------|-------------|------|
| 7    | 3007071     | 1    |
| 21   | 4007816     | 8    |
| 37   | m15002      | 4    |
| 44   | m13033      | 4    |
| 52   | m04355      | 2    |
| 63   | m04301      | 36   |
| 65   | m15730      | 2    |
| 71   | m01219      | 2    |

☉ ZÁKLAD STROJE

☉ UNTERBAU DER MASCHINE

☉ BÂTI DE LA MACHINE

☉ FOOTING OF THE MACHINE

☉ ОСНОВАНИЕ МАШИНЫ

☉ PODSTAWA MASZYNY



**VZ00030336**

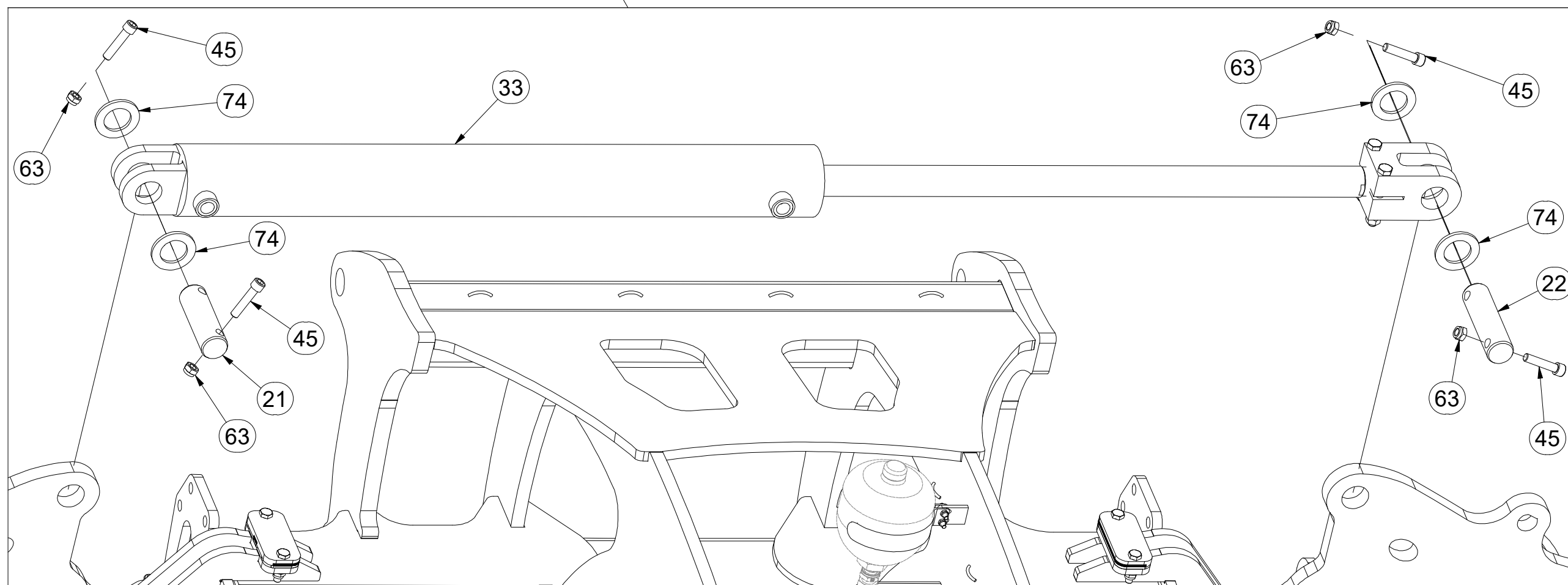
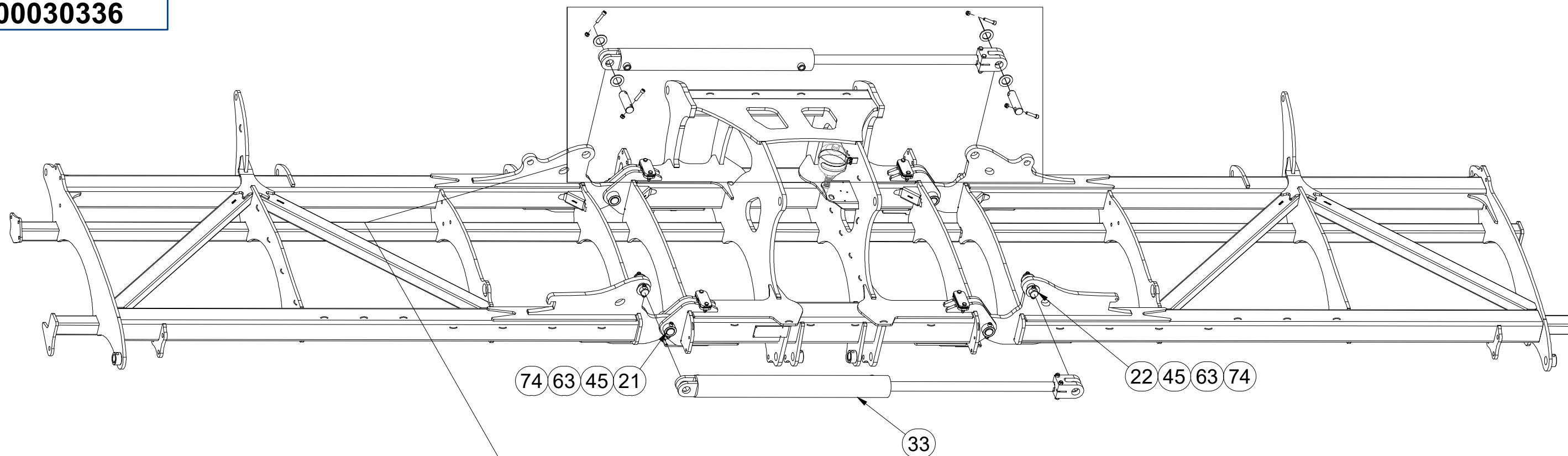

| Pos. | Part Number | Pcs. |
|------|-------------|------|
| 21   | 4007816     | 8    |
| 22   | 4012990     | 8    |
| 33   | m21525      | 2    |
| 45   | m14008      | 24   |
| 63   | m04301      | 36   |
| 74   | 4013139     | 24   |



Ⓒ ZÁKLAD STROJE

Ⓓ UNTERBAU DER MASCHINE

Ⓕ BÂTI DE LA MACHINE

Ⓖ FOOTING OF THE MACHINE

Ⓡ ОСНОВАНИЕ МАШИНЫ

Ⓢ PODSTAWA MASZYNY



**VZ00030336**

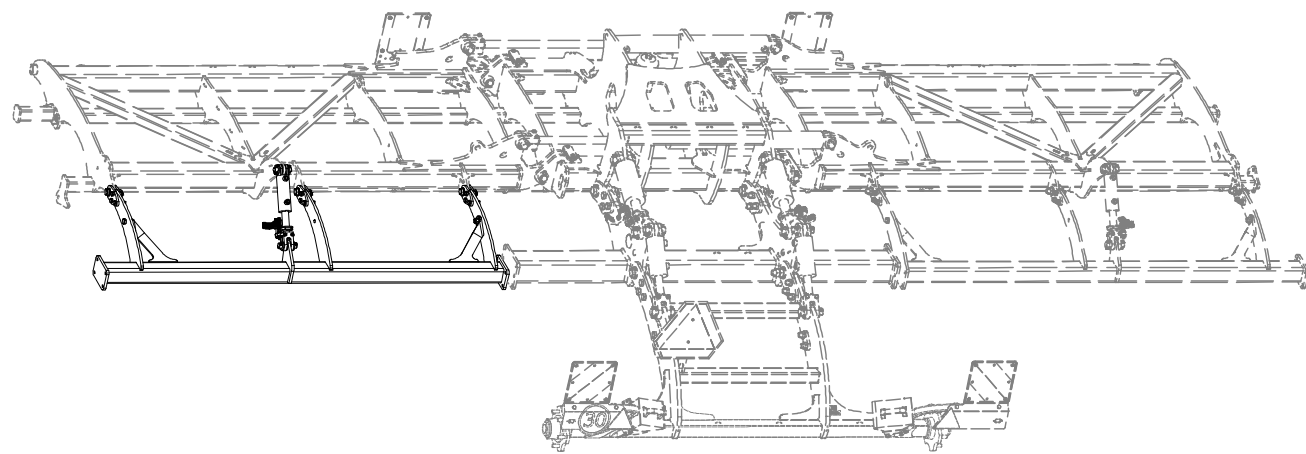
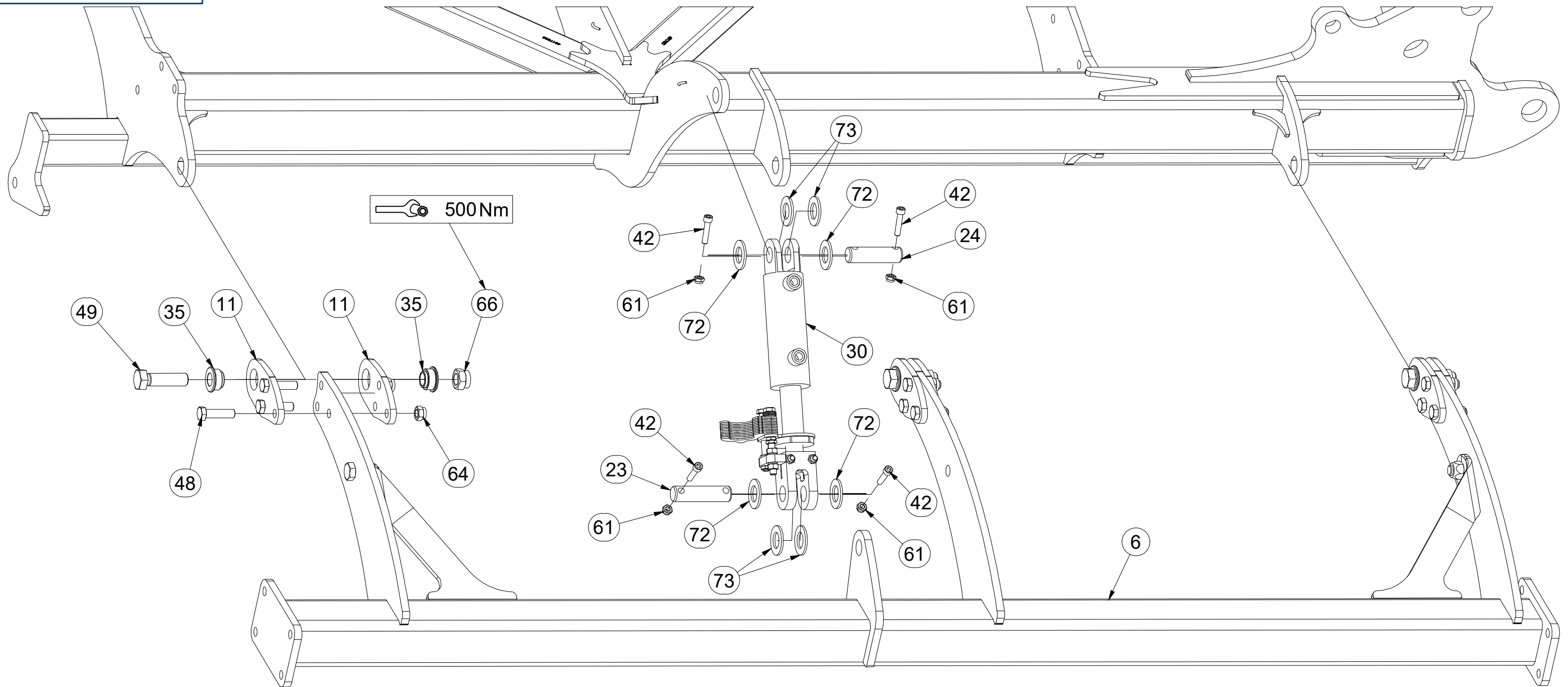

| Pos. | Part Number | Pcs. | Pos. | Part Number | Pcs. |
|------|-------------|------|------|-------------|------|
| 6    | 3008714     | 1    | 48   | m14482      | 18   |
| 11   | 4014704     | 12   | 49   | m08532      | 6    |
| 23   | 4007639     | 2    | 61   | m03775      | 16   |
| 24   | 4007584     | 2    | 64   | m03683      | 18   |
| 30   | 4015781     | 2    | 66   | m07147      | 12   |
| 35   | m14506      | 12   | 72   | m14029      | 8    |
| 42   | m14143      | 8    | 73   | m02866      | 8    |

Ⓒ ZÁKLAD STROJE

Ⓓ UNTERBAU DER MASCHINE

Ⓕ BÂTI DE LA MACHINE

Ⓖ FOOTING OF THE MACHINE

Ⓡ ОСНОВАНИЕ МАШИНЫ

Ⓟ PODSTAWA MASZYNY



**VZ00030336**

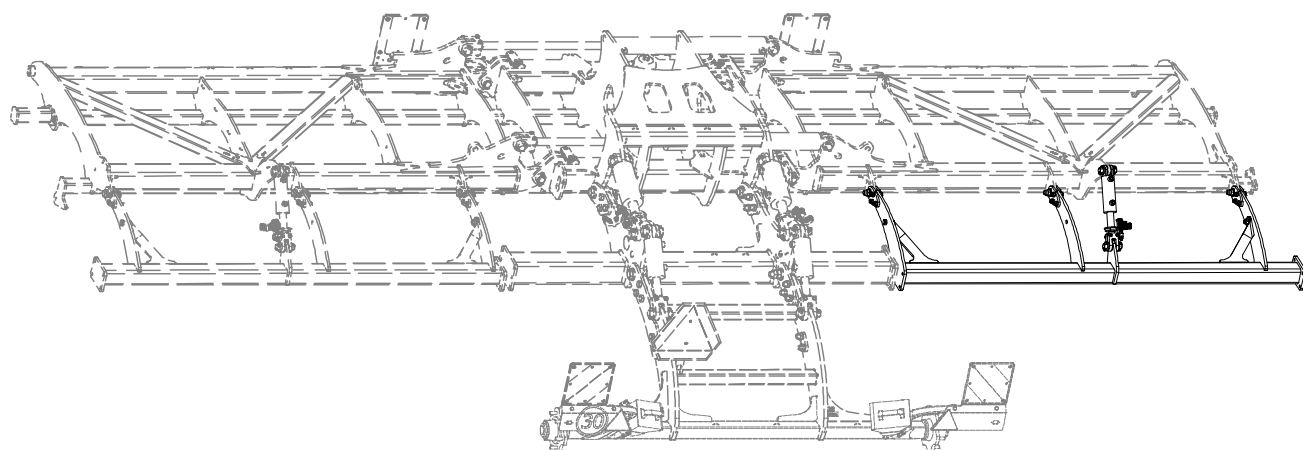
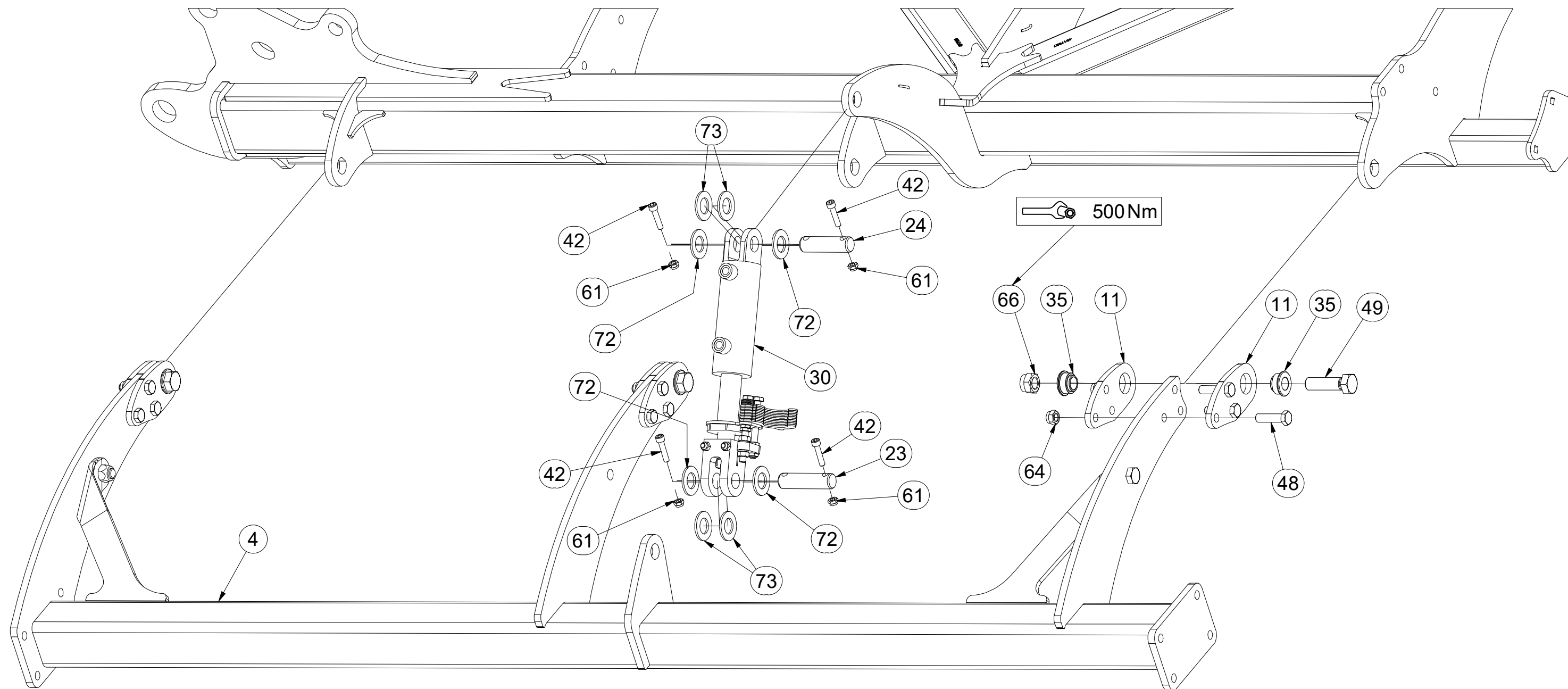

| Pos. | Part Number | Pcs. | Pos. | Part Number | Pcs. |
|------|-------------|------|------|-------------|------|
| 4    | 3008715     | 1    | 48   | m14482      | 18   |
| 11   | 4014704     | 12   | 49   | m08532      | 6    |
| 23   | 4007639     | 2    | 61   | m03775      | 16   |
| 24   | 4007584     | 2    | 64   | m03683      | 18   |
| 30   | 4015781     | 2    | 66   | m07147      | 12   |
| 35   | m14506      | 12   | 72   | m14029      | 8    |
| 42   | m14143      | 8    | 73   | m02866      | 8    |

☉ ZÁKLAD STROJE

Ⓧ UNTERBAU DER MASCHINE

Ⓧ BÂTI DE LA MACHINE

**VZ00030336**

Ⓧ FOOTING OF THE MACHINE

Ⓧ ОСНОВАНИЕ МАШИНЫ

Ⓧ PODSTAWA MASZYNY

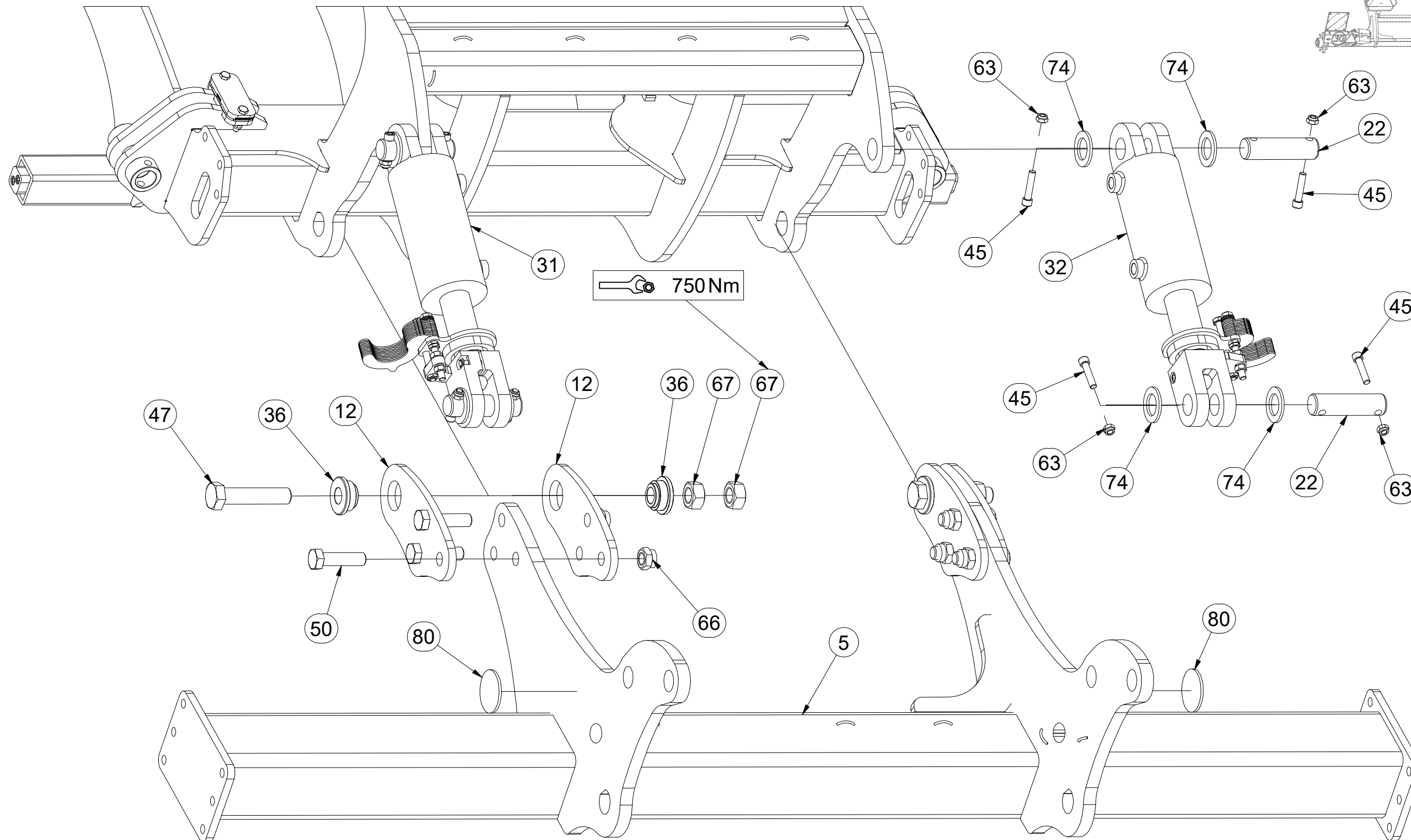
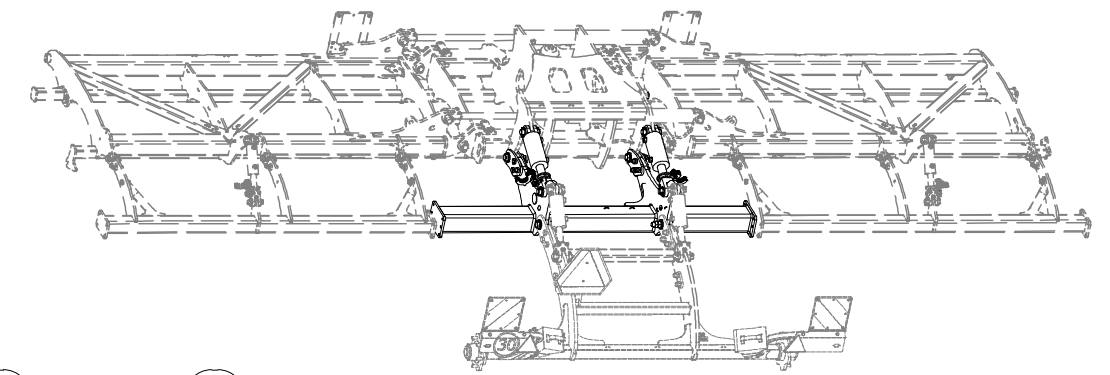

| Pos. | Part Number | Pcs. |
|------|-------------|------|
| 5    | 3008716     | 1    |
| 12   | 4015673     | 4    |
| 22   | 4012990     | 8    |
| 31   | VZ00011042  | 1    |
| 32   | VZ00011113  | 1    |
| 36   | m14505      | 8    |
| 45   | m14008      | 24   |
| 47   | m14856      | 4    |
| 50   | m14495      | 6    |
| 63   | m04301      | 36   |
| 66   | m07147      | 12   |
| 67   | m01309      | 8    |
| 74   | 4013139     | 24   |
| 80   | m02579      | 2    |

☉ ZÁKLAD STROJE

Ⓧ UNTERBAU DER MASCHINE

Ⓧ BÂTI DE LA MACHINE

Ⓧ FOOTING OF THE MACHINE

Ⓧ ОСНОВАНИЕ МАШИНЫ

Ⓧ PODSTAWA MASZYNY



**VZ00030336**

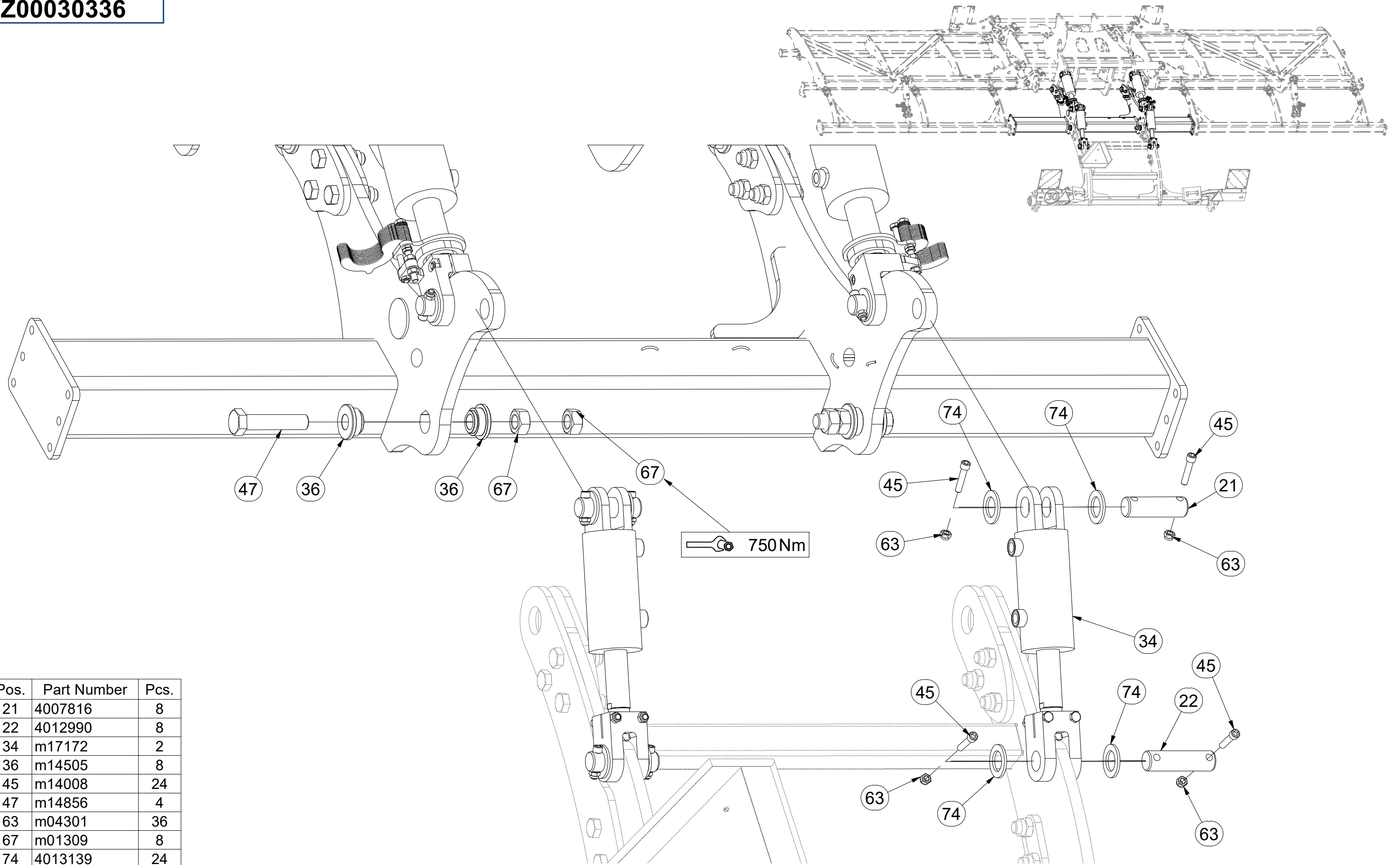

| Pos. | Part Number | Pcs. |
|------|-------------|------|
| 21   | 4007816     | 8    |
| 22   | 4012990     | 8    |
| 34   | m17172      | 2    |
| 36   | m14505      | 8    |
| 45   | m14008      | 24   |
| 47   | m14856      | 4    |
| 63   | m04301      | 36   |
| 67   | m01309      | 8    |
| 74   | 4013139     | 24   |

CZ TERČ PŘEDNÍ  
 D SCHILD, VORDERES  
 F CIBLE AVANT

GB FRONT DISC  
 RU ЩИТОК ПЕРЕДНИЙ  
 PL TARCZA PRZEDNIA



**4025088**

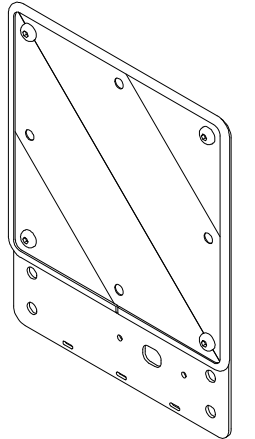
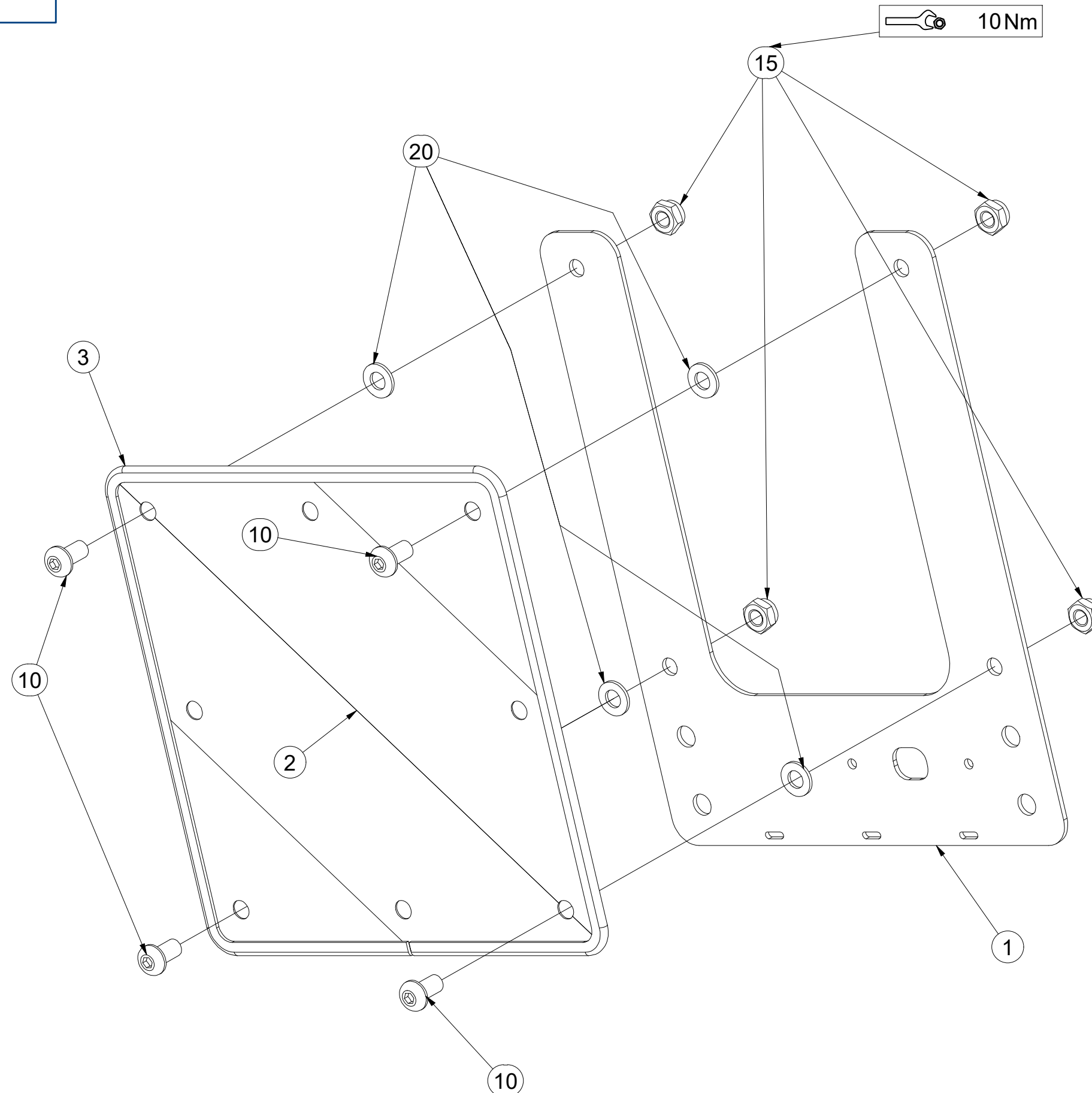

| Pos. | Part Number | Pcs. |
|------|-------------|------|
| 1    | 4025090     | 1    |
| 2    | m18855      | 1    |
| 3    | 9005707     | 1    |
| 10   | m16637      | 4    |
| 15   | m03775      | 4    |
| 20   | m01209      | 4    |

CZ TERČ PŘEDNÍ  
 D SCHILD, VORDERES  
 F CIBLE AVANT

GB FRONT DISC  
 RU ЩИТОК ПЕРЕДНИЙ  
 PL TARCZA PRZEDNIA



**4025089**

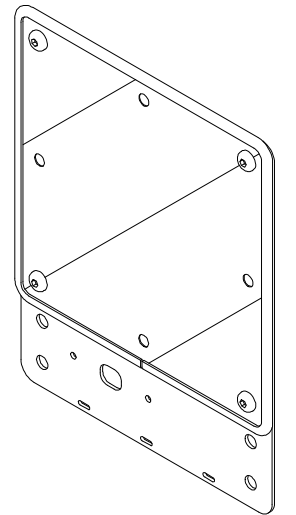
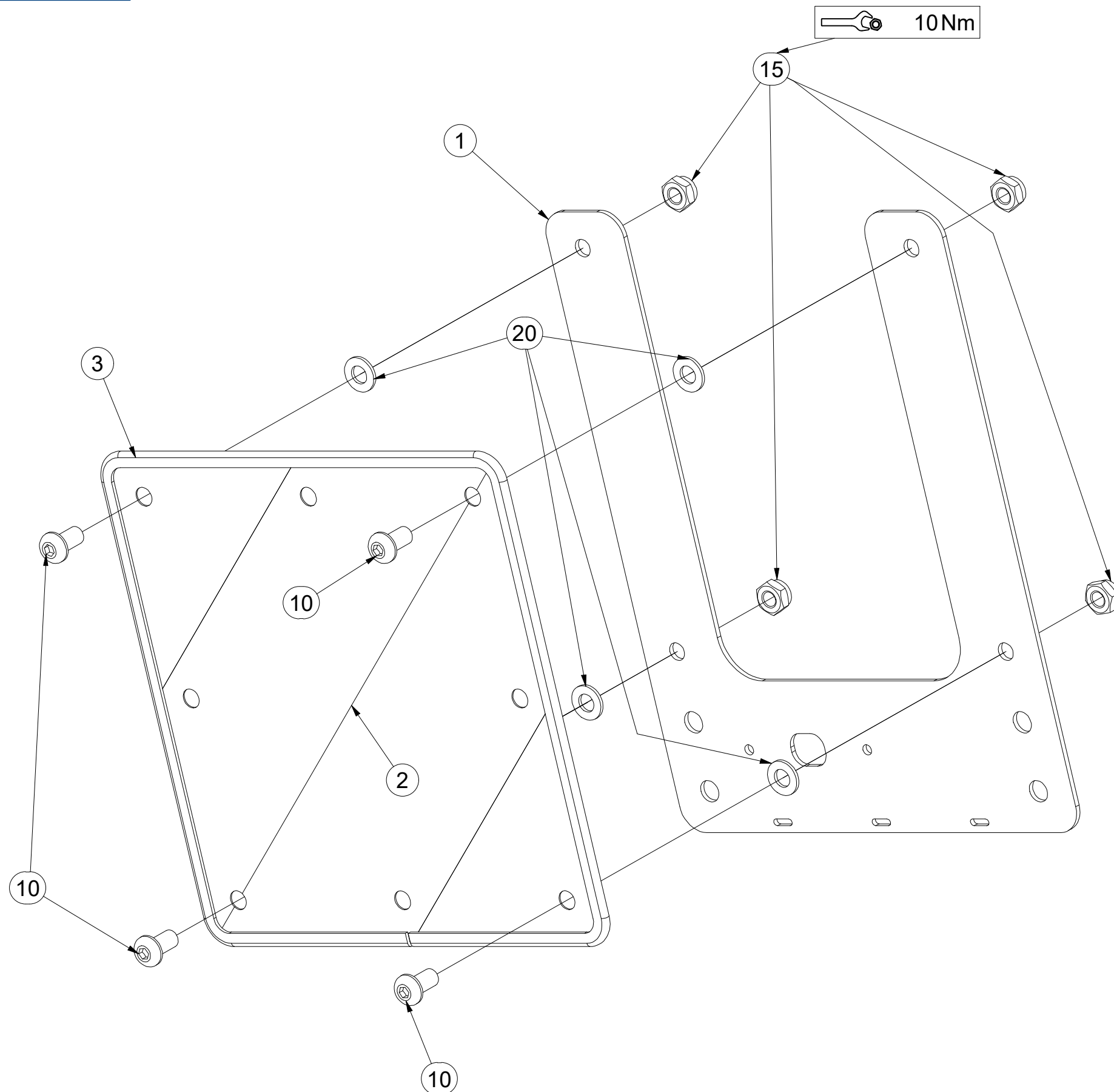

| Pos. | Part Number | Pcs. |
|------|-------------|------|
| 1    | 4025090     | 1    |
| 2    | m18855      | 1    |
| 3    | 9005707     | 1    |
| 10   | m16637      | 4    |
| 15   | m03775      | 4    |
| 20   | m01209      | 4    |

☉ KOPÍROVACÍ KOLA

☉ KOPIERRÄDER

☉ COPIAGE DU TERRAIN

☉ TRACING WHEELS

☉ КОПИРУЮЩЕЕ КОЛЕСА

☉ KOŁA KOPIUJĄCE



**3011554**

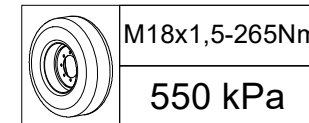
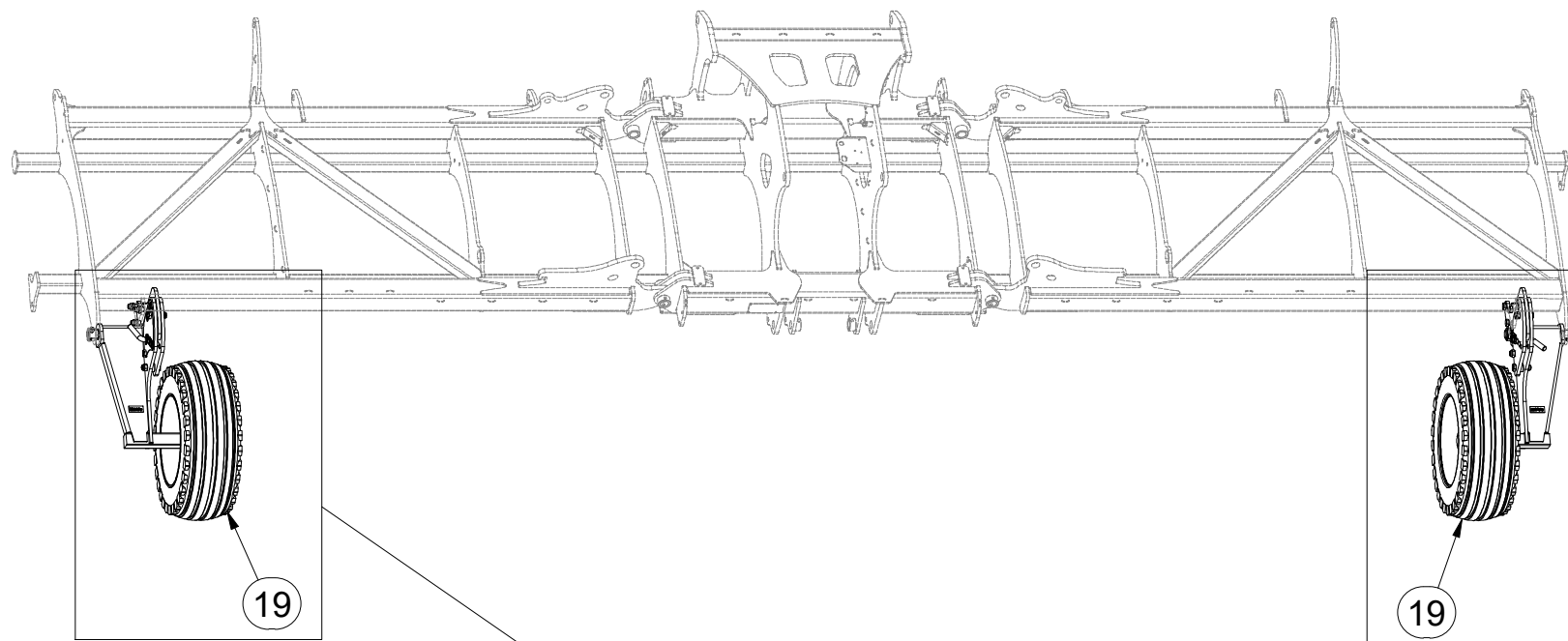

| Pos. | Part Number | Pcs. | Pos. | Part Number | Pcs. |
|------|-------------|------|------|-------------|------|
| 1    | 3011468     | 1    | 15   | 4011764     | 2    |
| 2    | 3011469     | 1    | 19   | m21946      | 2    |
| 3    | VZ00019975  | 1    | 20   | m13033      | 2    |
| 4    | VZ00019977  | 1    | 21   | m22861      | 6    |
| 5    | 4008355     | 2    | 22   | m05723      | 6    |
| 6    | 4008058     | 6    | 30   | m04301      | 2    |
| 7    | 4008312     | 1    | 31   | m05648      | 6    |
| 8    | 4008315     | 1    | 32   | m20599      | 6    |
| 9    | 4017145     | 2    | 40   | m10454      | 2    |
| 10   | 4015722     | 4    | 41   | m15782      | 2    |
| 11   | 4017146     | 2    | 42   | m12467      | 2    |
|      |             |      | 45   | m04958      | 2    |

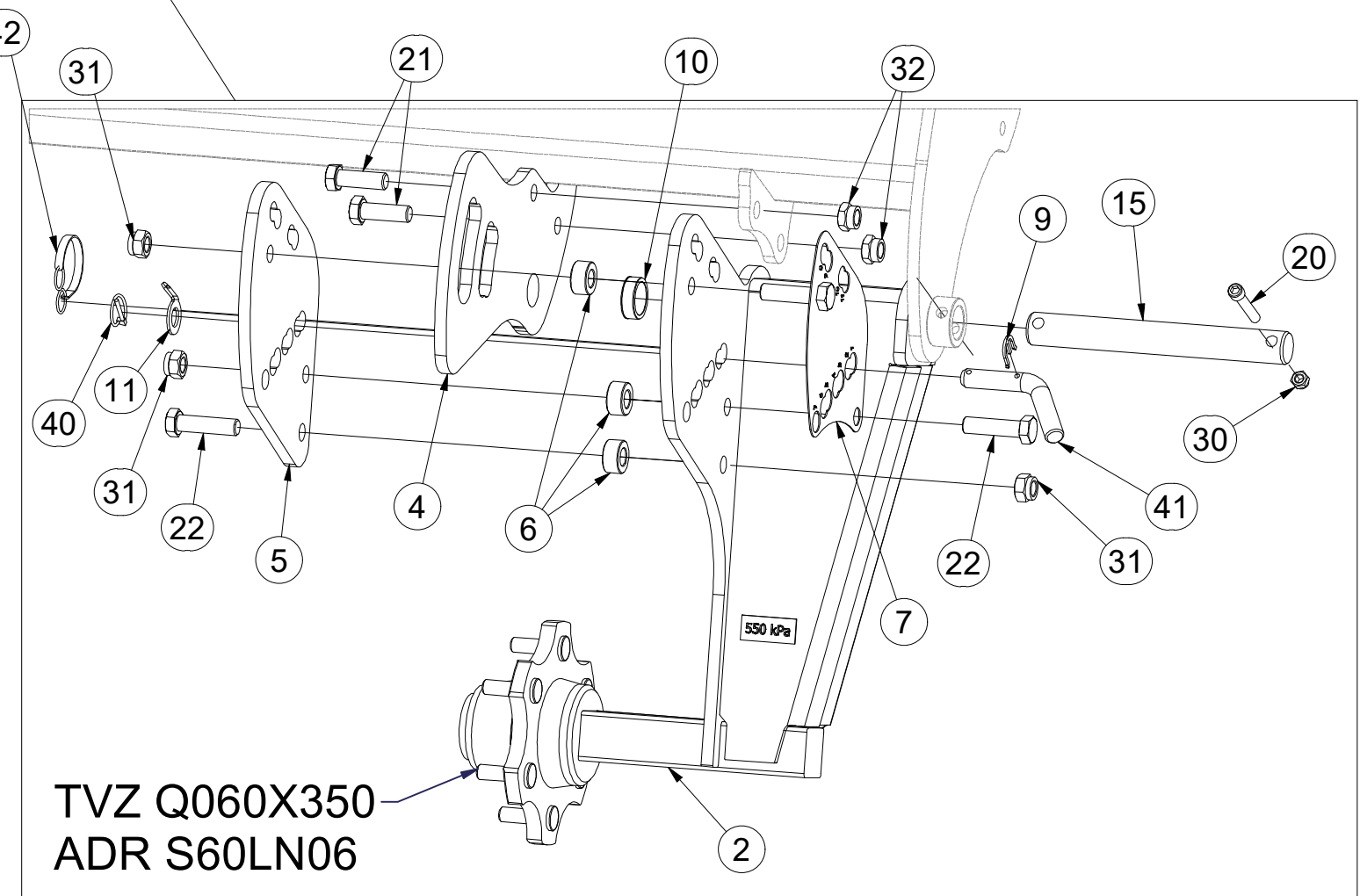
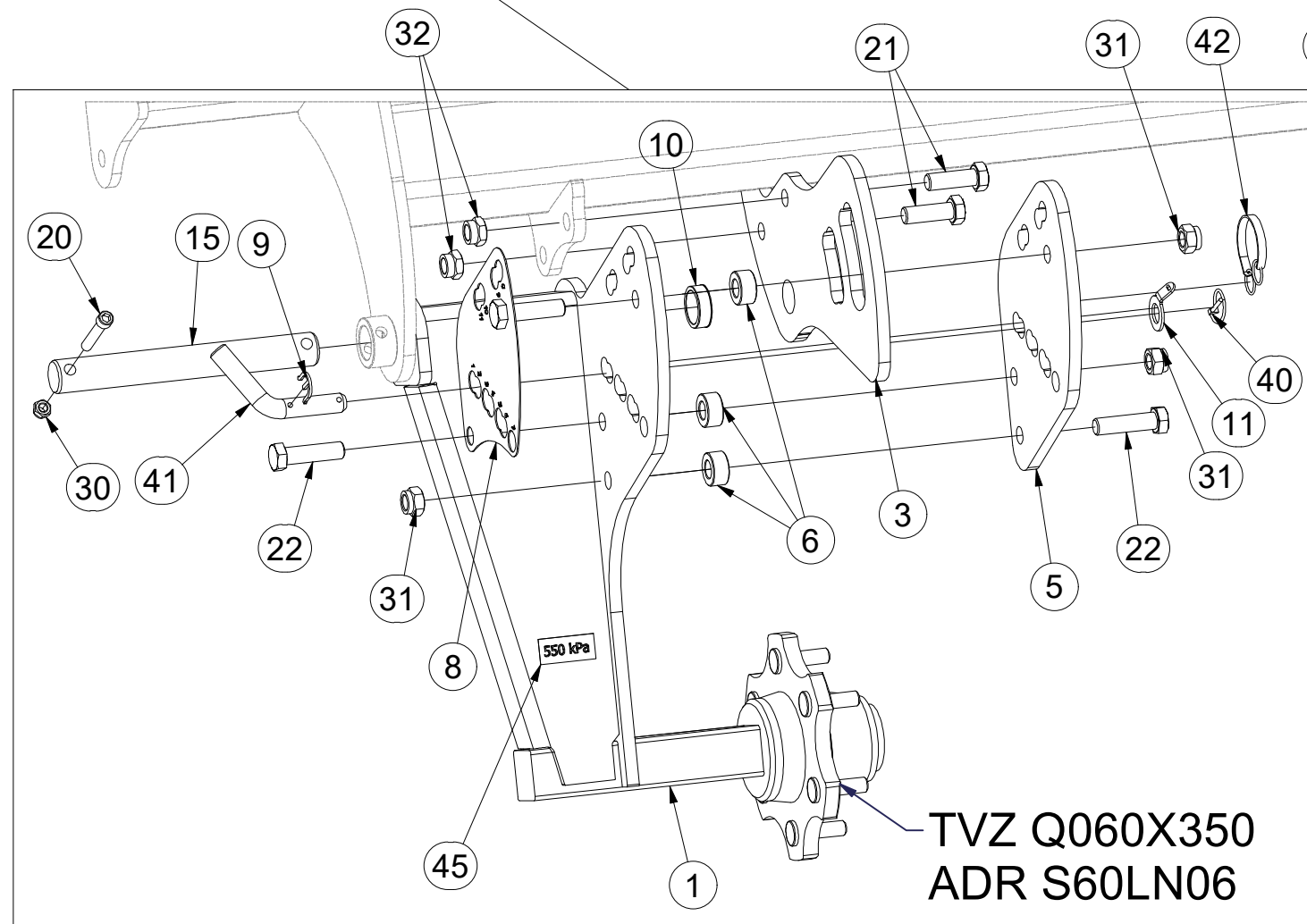

Ⓒ NÁPRAVA

Ⓓ ACHSE

Ⓕ ESSIEU

**Q060X350**

Ⓖ AXLE

Ⓡ OCB

Ⓟ OS

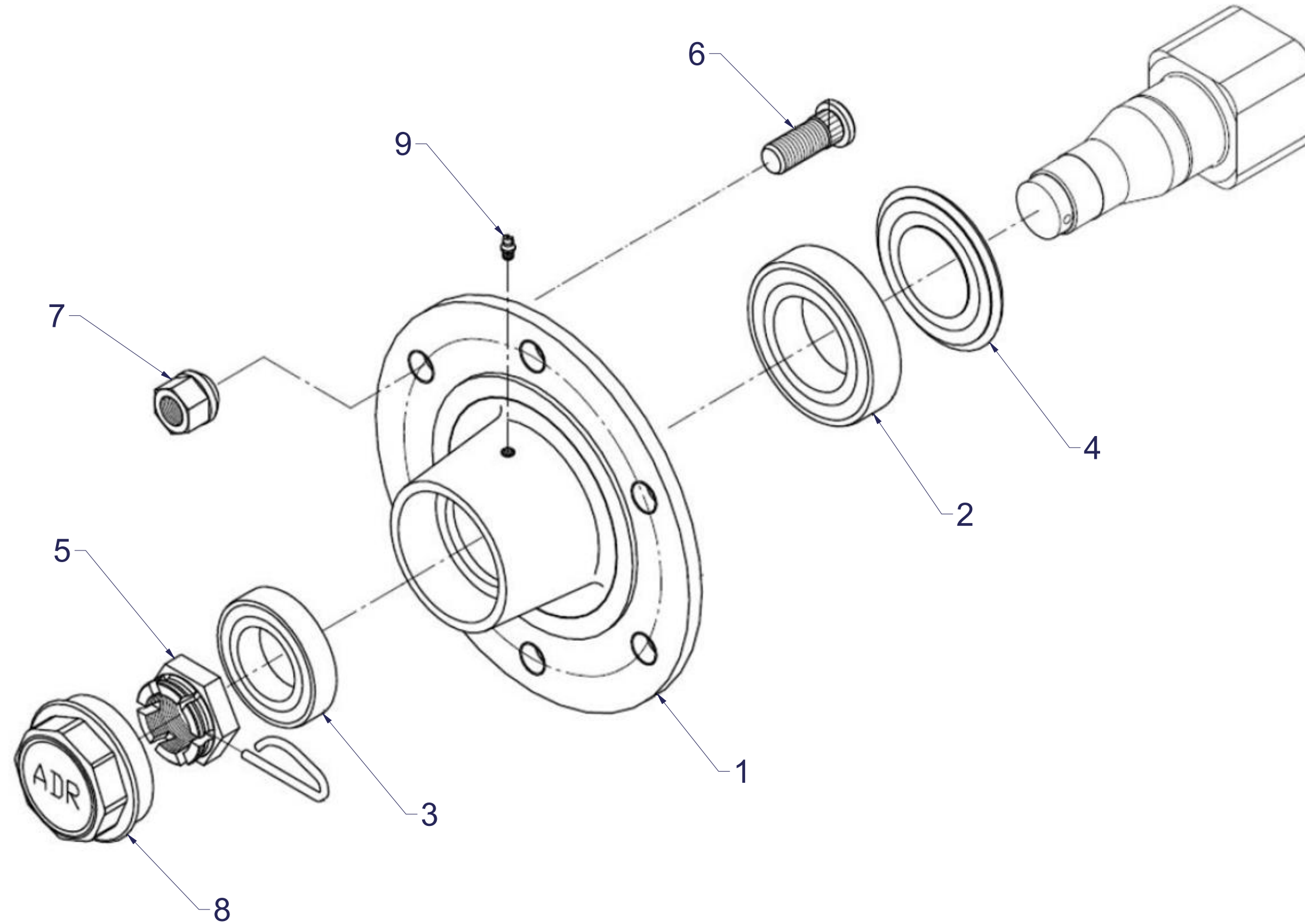

| Pos. | Part Number | Pcs. |
|------|-------------|------|
| 1    | m21713      | 1    |
| 2    | m07151      | 1    |
| 3    | m07152      | 1    |
| 4    | m21717      | 1    |
| 5    | m08169      | 1    |
| 6    | m08148      | 6    |
| 7    | m08163      | 6    |
| 8    | m21725      | 1    |
| 9    | m05698      | 1    |



Ⓒ NÁPRAVA

Ⓓ ACHSE

Ⓕ ESSIEU

Ⓖ AXLE

Ⓒ OCB

Ⓗ OS



**S60LN06**

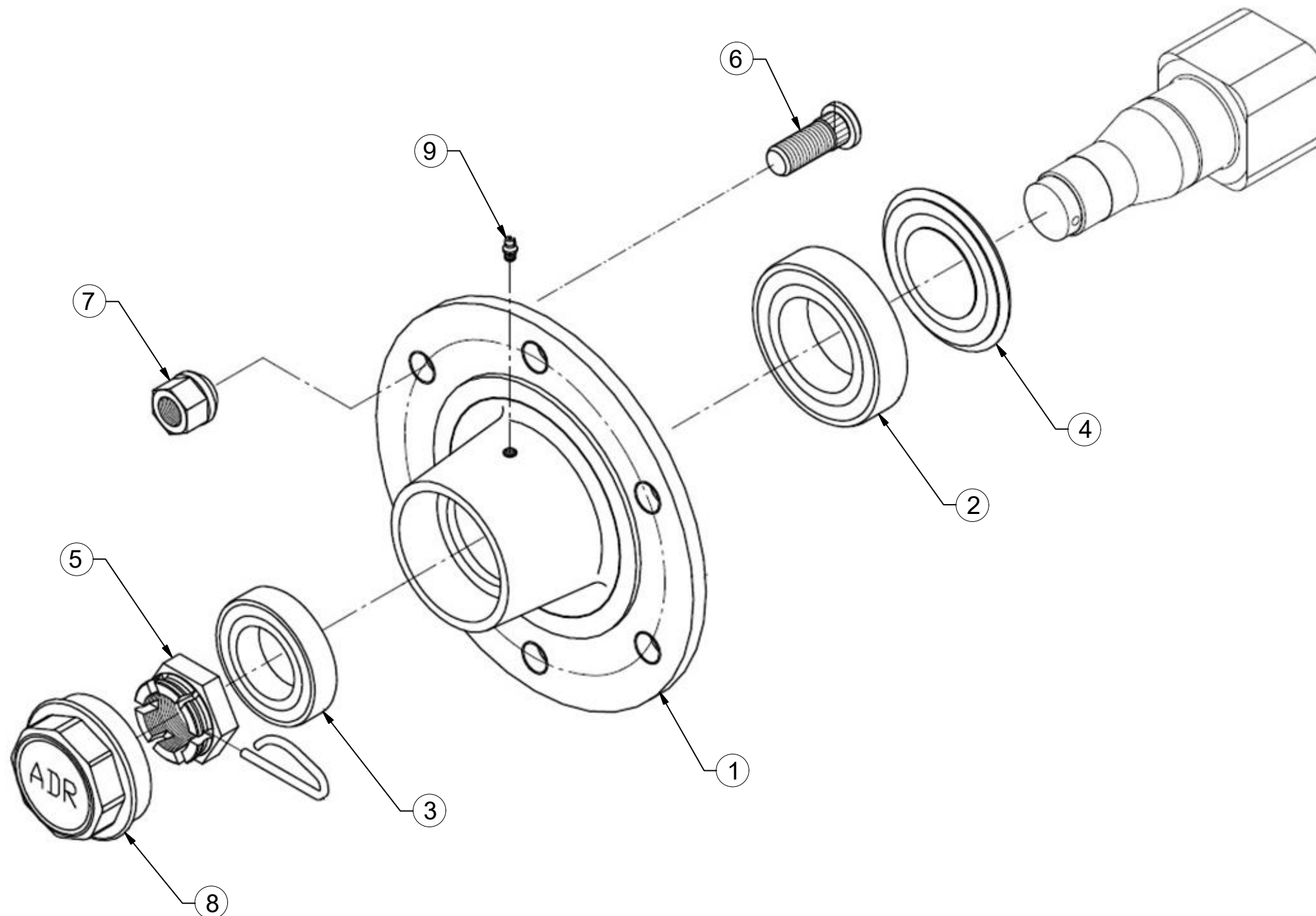

| Pos. | Part Number | Pcs. |
|------|-------------|------|
| 1    | m15631      | 1    |
| 2    | m07151      | 1    |
| 3    | m07152      | 1    |
| 4    | m15058      | 1    |
| 5    | m08169      | 1    |
| 6    | m08148      | 6    |
| 7    | m08163      | 6    |
| 8    | m15123      | 1    |
| 9    | m05698      | 1    |

CZ SADA DISKŮ  
 D SCHEIBENSATZ  
 F KIT DE DISQUES

GB DISC SET  
 RU КОМПЛЕКТ ДИСКОВ  
 PL ZESTAW TALERZY



**VZ00024356**

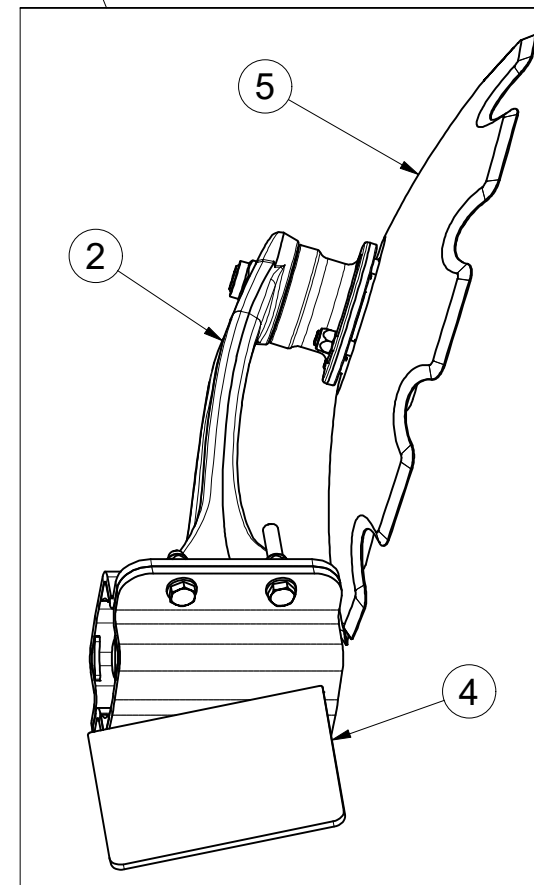
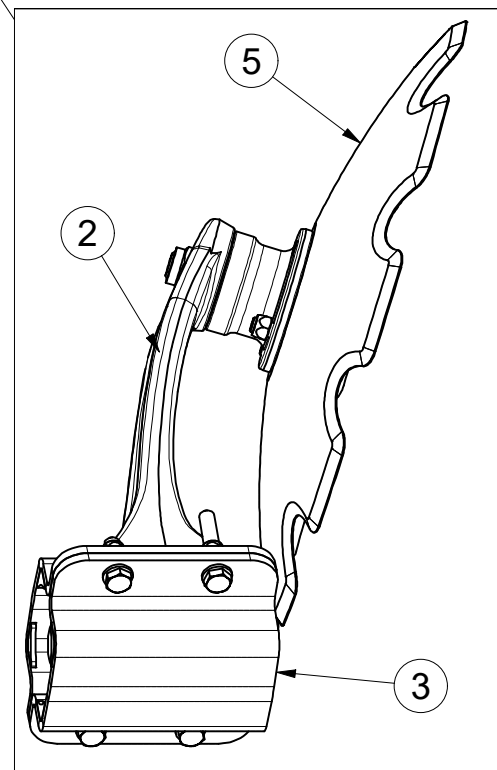
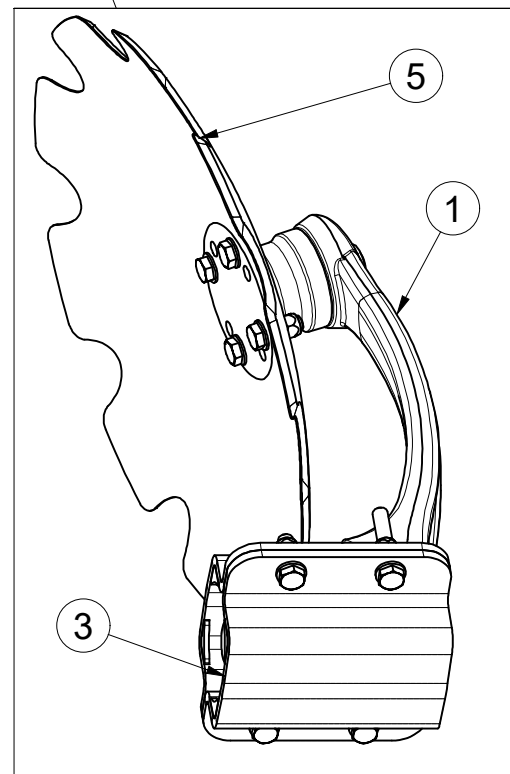
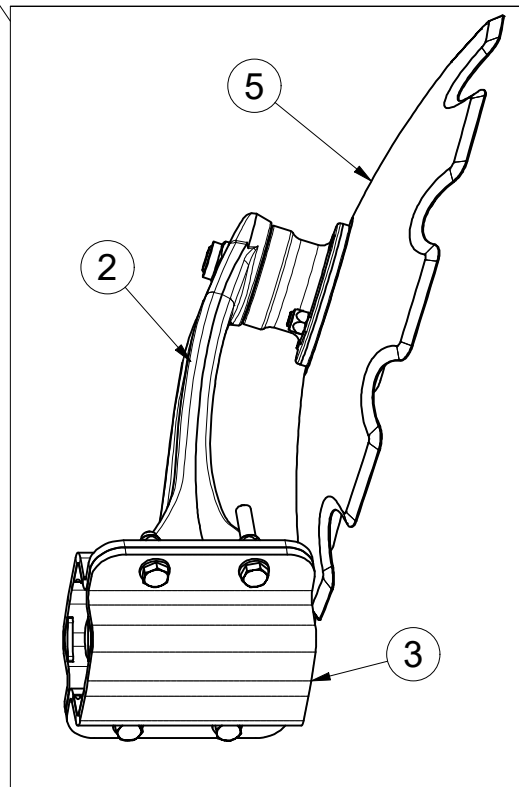
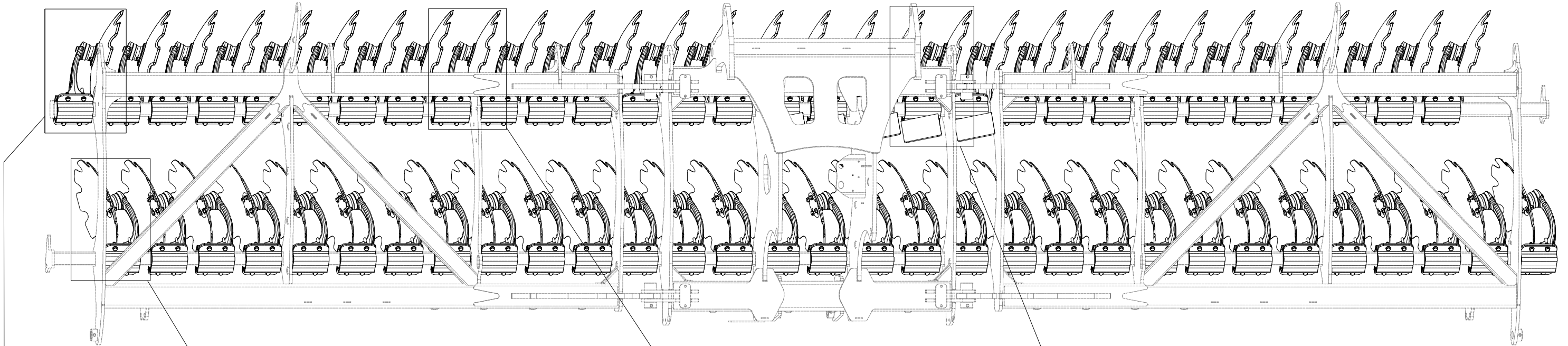

| Pos. | Part Number | Pcs. |
|------|-------------|------|
| 1    | 3008374     | 31   |
| 2    | 3008375     | 30   |
| 3    | 9004269     | 56   |
| 4    | 4016392     | 5    |
| 5    | 3007653     | 61   |

CZ PŘEDNÍ DISK  
 D SCHEIBE, VORDERE  
 F DISQUE AVANT

GB FRONT DISC  
 RU ДИСК ПЕРЕДНИЙ  
 PL TALERZ PRZEDNI



**3008374**

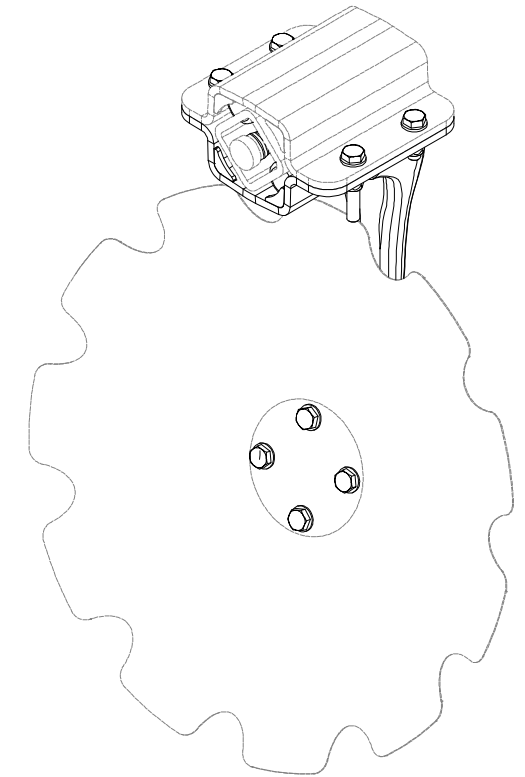
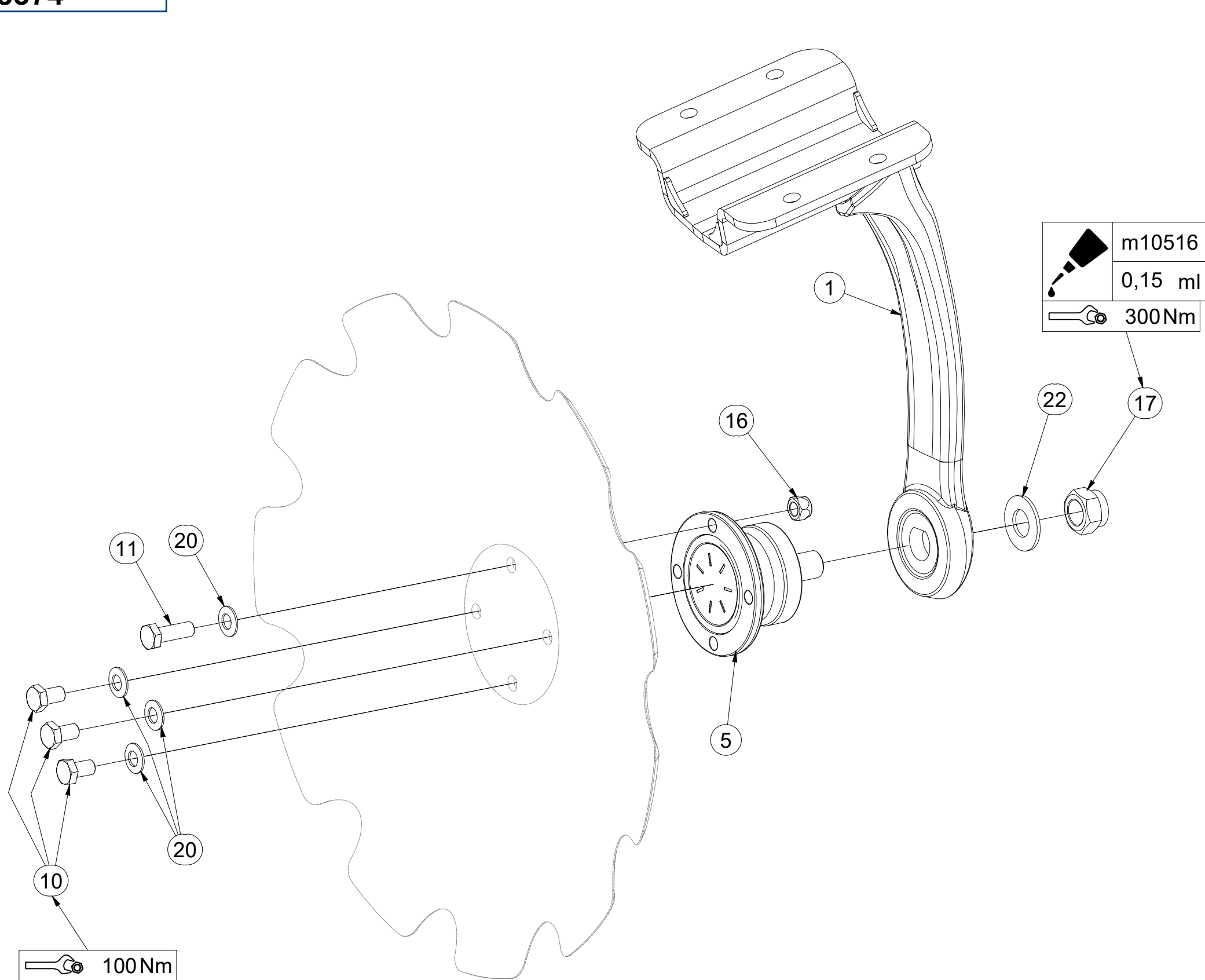

| Pos. | Part Number | Pcs. |
|------|-------------|------|
| 1    | 3008382     | 1    |
| 5    | m11308      | 1    |
| 10   | m11309      | 3    |
| 11   | m11559      | 1    |
| 16   | m11560      | 1    |
| 17   | m11313      | 1    |
| 20   | m17545      | 4    |
| 22   | VZ00011395  | 1    |

CZ PŘEDNÍ DISK  
 D SCHEIBE, VORDERE  
 F DISQUE AVANT

GB FRONT DISC  
 RU ДИСК ПЕРЕДНИЙ  
 PL TALERZ PRZEDNI



**3008374**

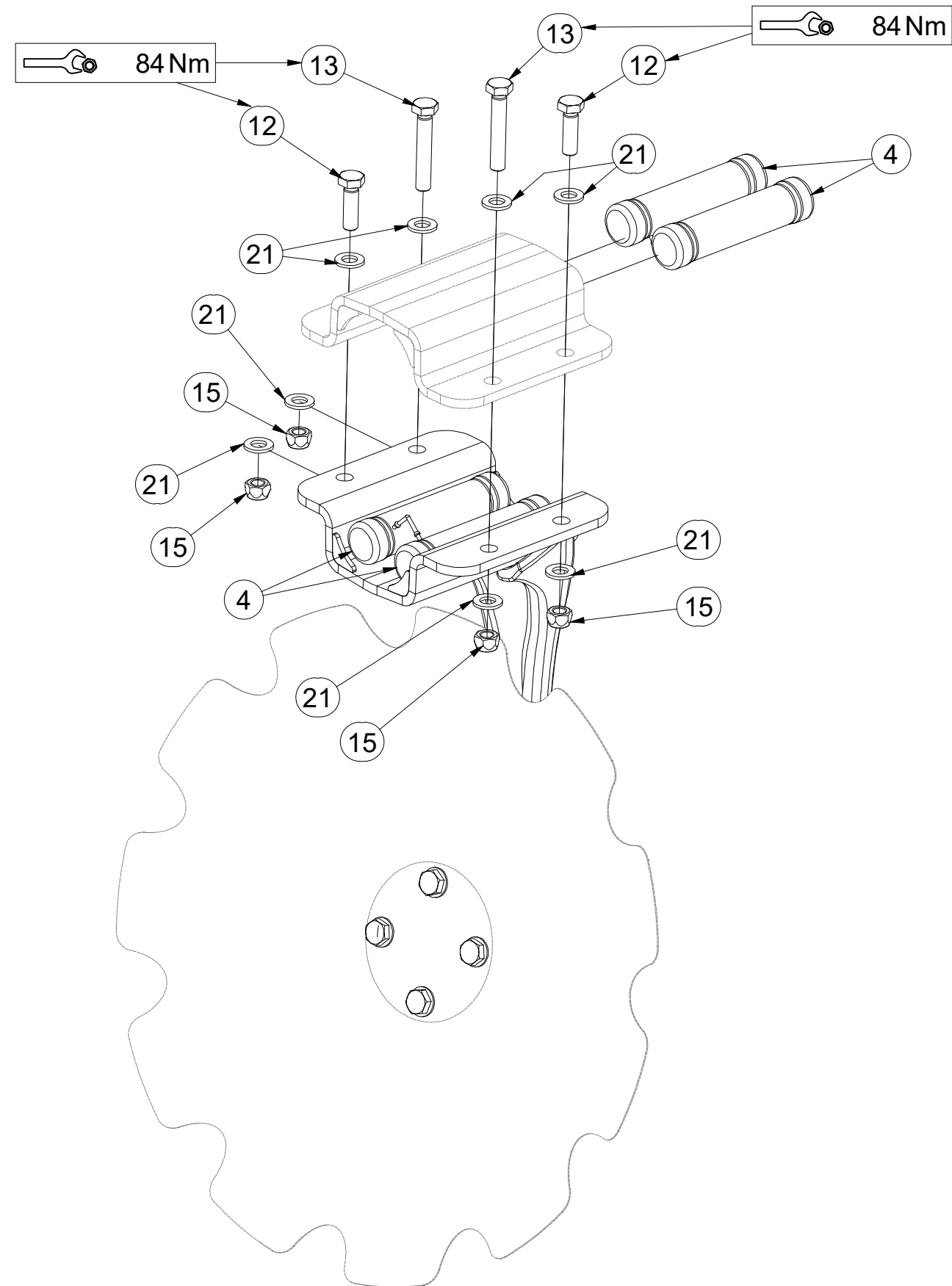

| Pos. | Part Number | Pcs. |
|------|-------------|------|
| 4    | VZ00003901  | 4    |
| 12   | m17657      | 2    |
| 13   | m17653      | 2    |
| 15   | m12134      | 4    |
| 21   | m17741      | 8    |

CZ ZADNÍ DISK  
 D SCHEIBE, HINTERE  
 F DISQUE ARRIÈRE

GB REAR DISC  
 RU ДИСК ЗАДНИЙ  
 PL TALERZ TYLNY



**3008375**

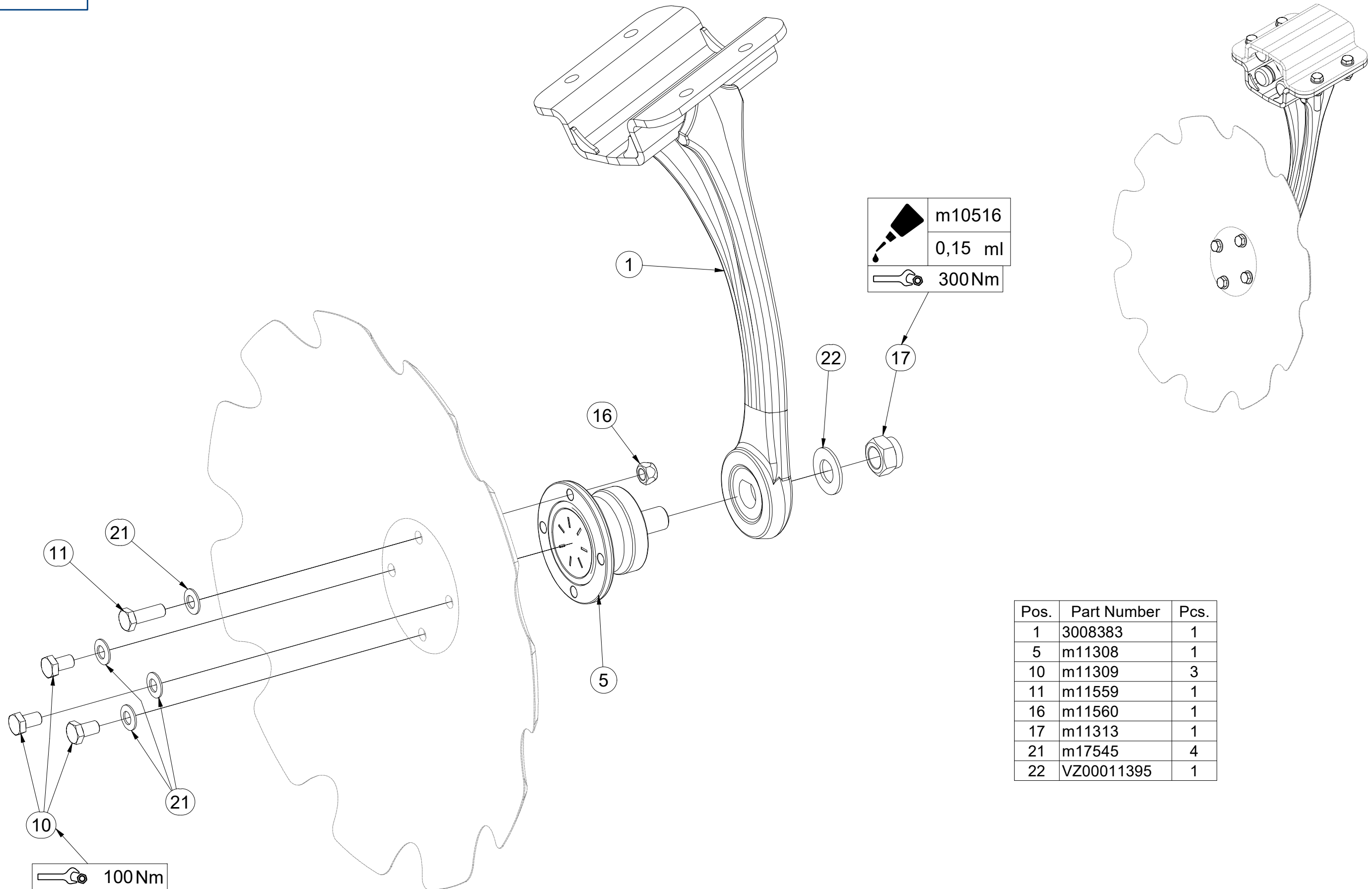

| Pos. | Part Number | Pcs. |
|------|-------------|------|
| 1    | 3008383     | 1    |
| 5    | m11308      | 1    |
| 10   | m11309      | 3    |
| 11   | m11559      | 1    |
| 16   | m11560      | 1    |
| 17   | m11313      | 1    |
| 21   | m17545      | 4    |
| 22   | VZ00011395  | 1    |

CZ ZADNÍ DISK  
 D SCHEIBE, HINTERE  
 F DISQUE ARRIÈRE

GB REAR DISC  
 RU ДИСК ЗАДНИЙ  
 PL TALERZ TYLNY



**3008375**

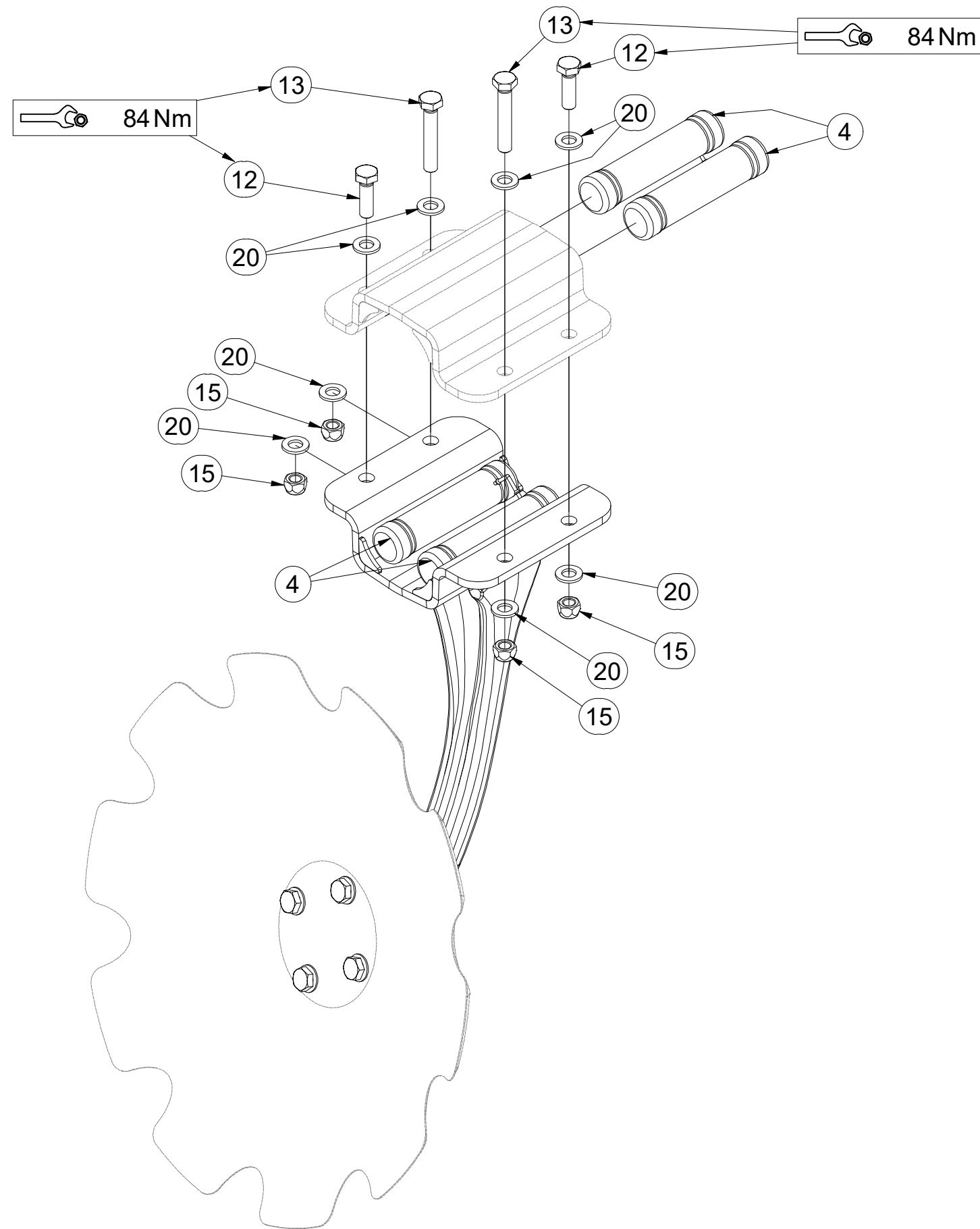

| Pos. | Part Number | Pcs. |
|------|-------------|------|
| 4    | VZ00003901  | 4    |
| 12   | m17657      | 2    |
| 13   | m17653      | 2    |
| 15   | m12134      | 4    |
| 20   | m17741      | 8    |

CZ DEFLEKTOR LEVÝ  
 D DEFLEKTOR, LINKER  
 F DÉFLECTEUR GAUCHE

GB DEFLECTOR LEFT  
 RU ДЕФЛЕКТОР ЛЕВЫЙ  
 PL DEFLEKTOR LEWY



**3009574**

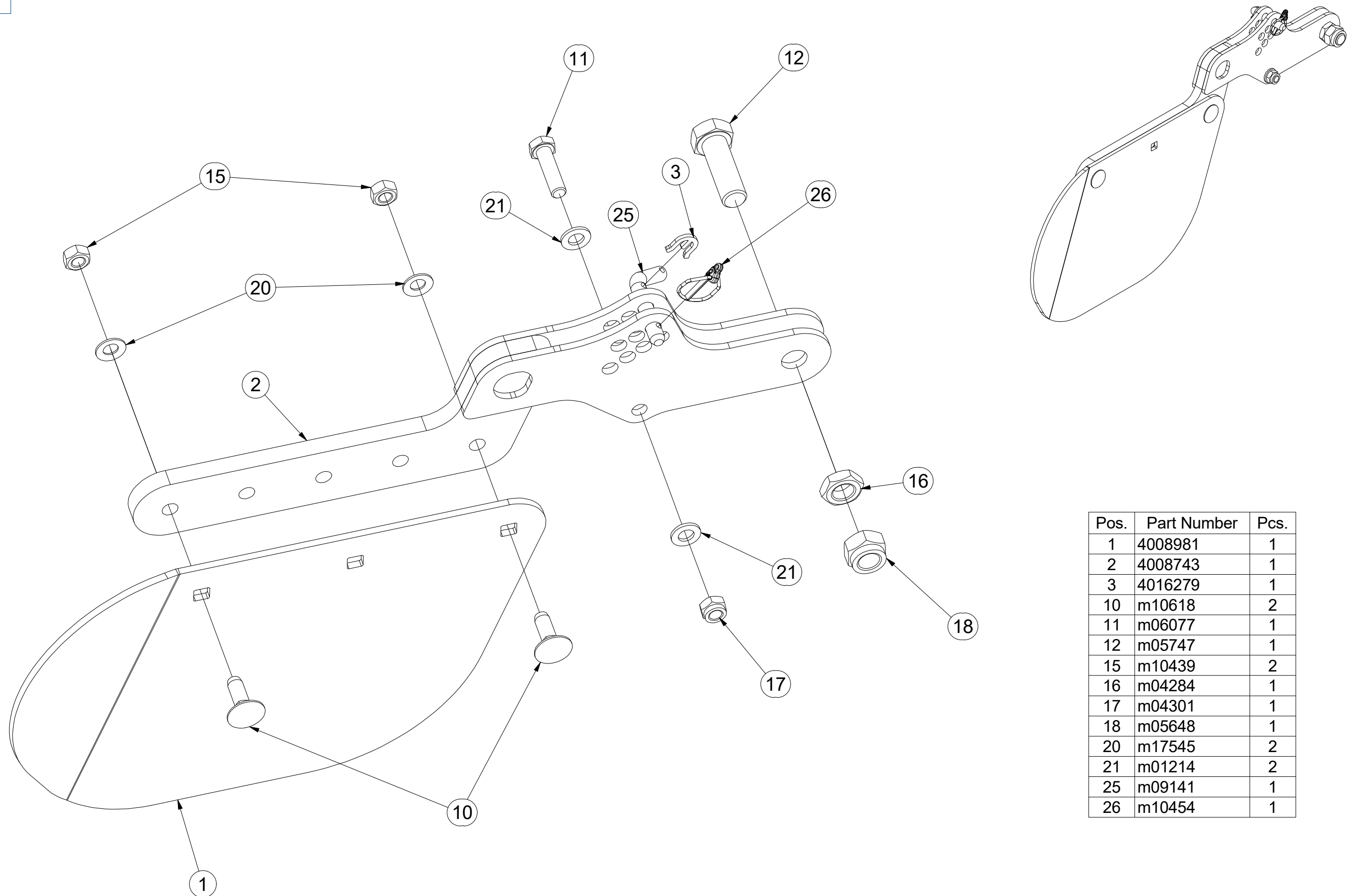

| Pos. | Part Number | Pcs. |
|------|-------------|------|
| 1    | 4008981     | 1    |
| 2    | 4008743     | 1    |
| 3    | 4016279     | 1    |
| 10   | m10618      | 2    |
| 11   | m06077      | 1    |
| 12   | m05747      | 1    |
| 15   | m10439      | 2    |
| 16   | m04284      | 1    |
| 17   | m04301      | 1    |
| 18   | m05648      | 1    |
| 20   | m17545      | 2    |
| 21   | m01214      | 2    |
| 25   | m09141      | 1    |
| 26   | m10454      | 1    |

ⒸZ DEFLEKTOR PRAVÝ  
Ⓓ DEFLEKTOR, RECHTER  
Ⓕ D'EFLECTEUR DROIT

**VZ00029983**

ⒸB DEFLECTOR RIGHT  
Ⓔ ДЕФЛЕКТОР ПРАВЫЙ  
ⒸL DEFLEKTOR PRAWY

**Farmet**

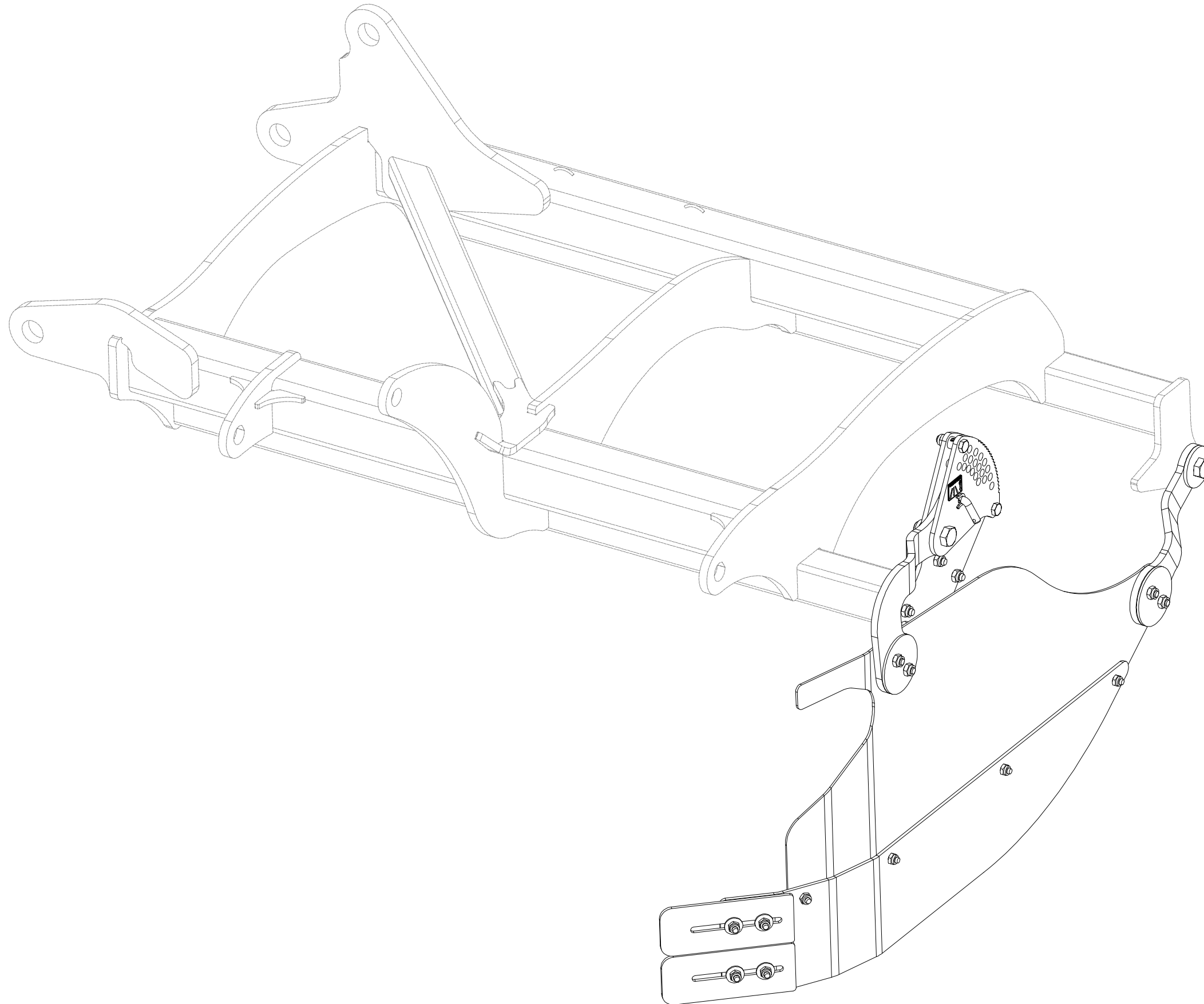



CZ DEFLEKTOR PRAVÝ  
 D DEFLEKTOR, RECHTER  
 F DÉFLECTEUR DROIT

GB DEFLECTOR RIGHT  
 RU ДЕФЛЕКТОР ПРАВЫЙ  
 PL DEFLEKTOR PRAWY



**VZ00029983**

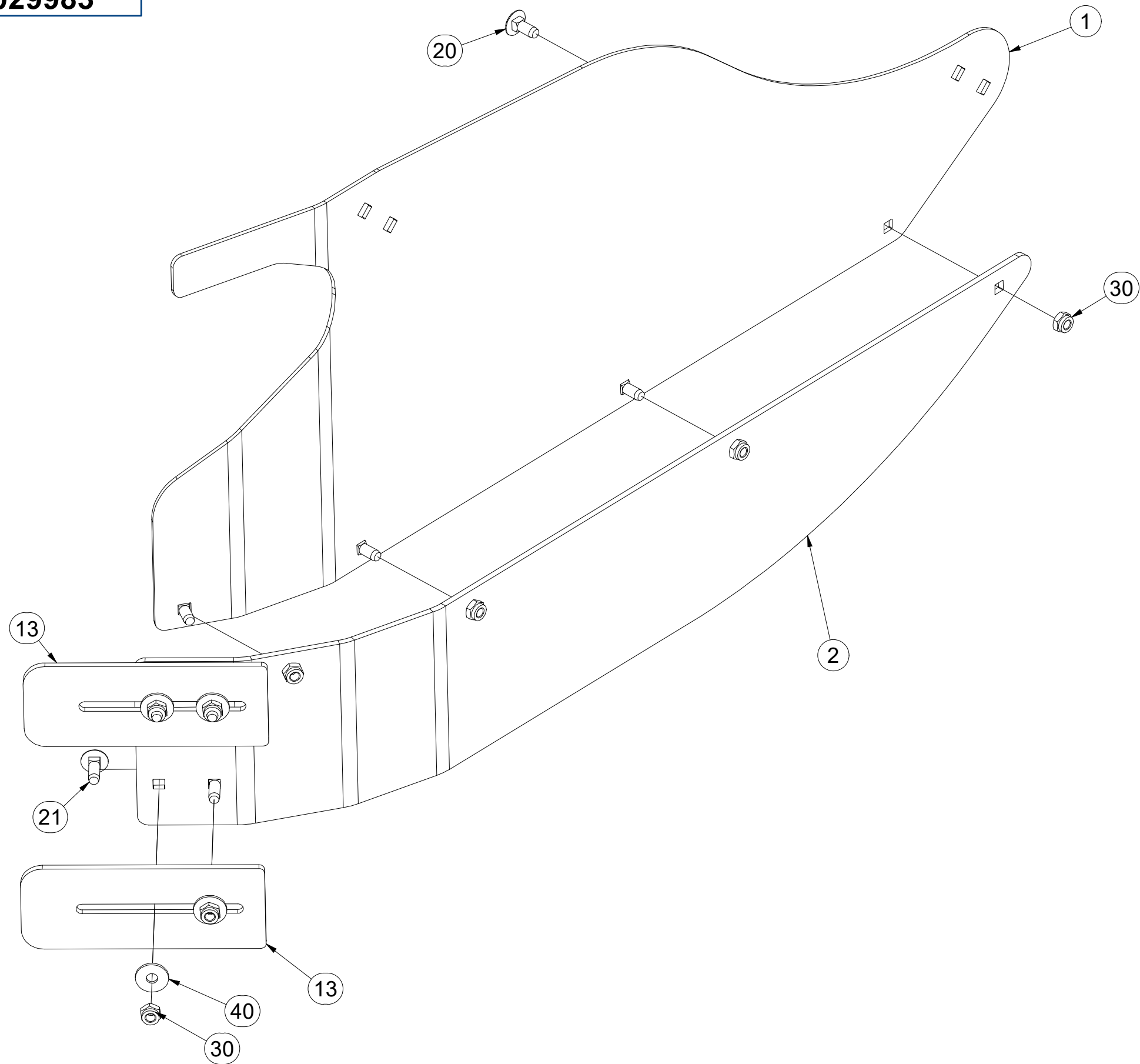

| Pos. | Part Number | Pcs. |
|------|-------------|------|
| 1    | VZ00023005  | 1    |
| 2    | VZ00022377  | 1    |
| 13   | VZ00022131  | 2    |
| 20   | m03129      | 4    |
| 21   | m19153      | 4    |
| 30   | m03775      | 8    |
| 40   | m16981      | 4    |

CZ DEFLEKTOR PRAVÝ  
 D DEFLEKTOR, RECHTER  
 F DÉFLECTEUR DROIT

GB DEFLECTOR RIGHT  
 RU ДЕФЛЕКТОР ПРАВЫЙ  
 PL DEFLEKTOR PRAWY



**VZ00029983**

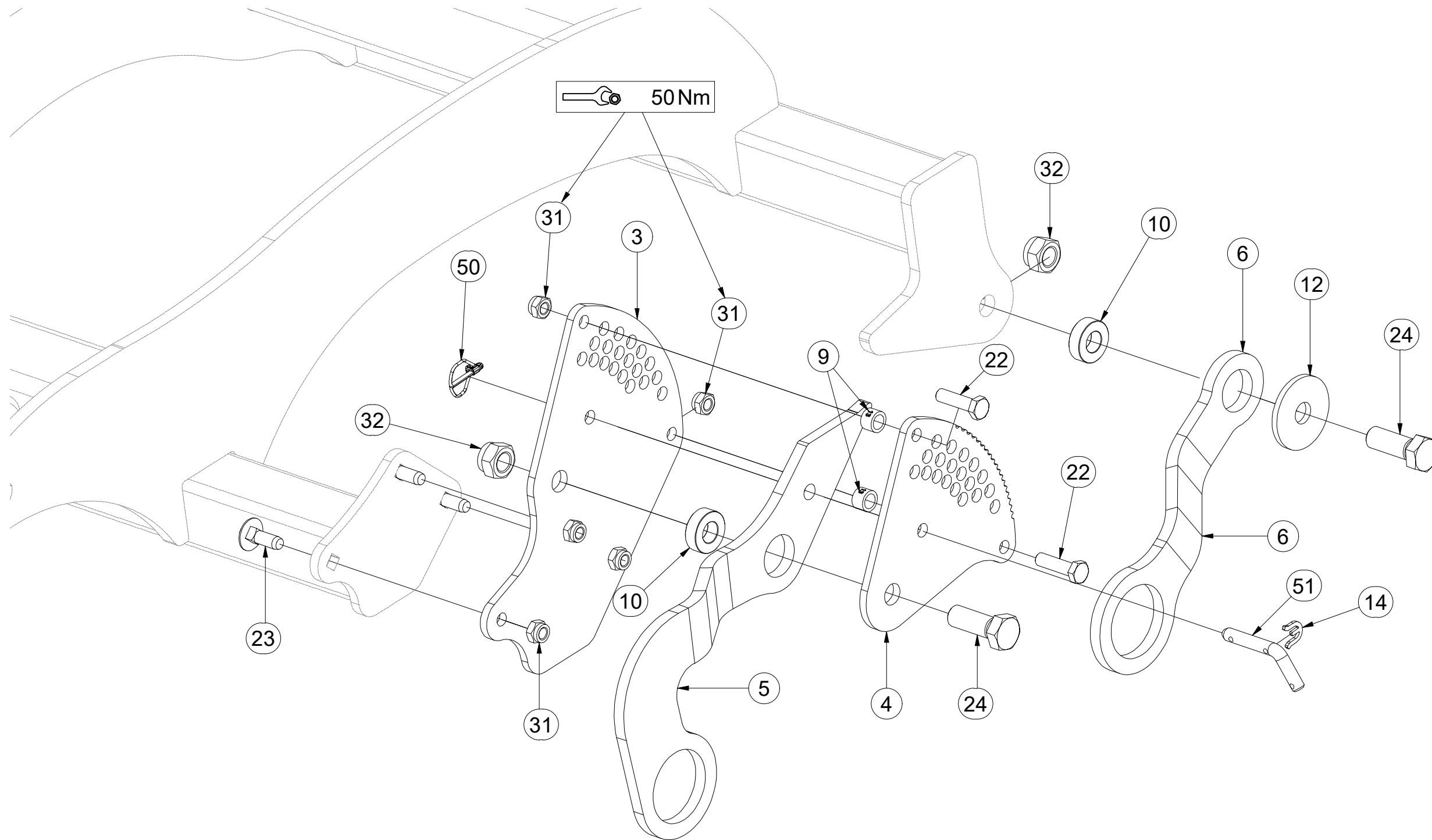

| Pos. | Part Number | Pcs. |
|------|-------------|------|
| 3    | VZ00029973  | 1    |
| 4    | VZ00028051  | 1    |
| 5    | VZ00028107  | 1    |
| 6    | VZ00022038  | 1    |
| 9    | VZ00022102  | 2    |
| 10   | VZ00022394  | 2    |
| 12   | VZ00022044  | 1    |
| 14   | 4016279     | 1    |
| 22   | m06077      | 2    |
| 23   | m10618      | 7    |
| 24   | m12771      | 2    |
| 31   | m04301      | 9    |
| 32   | m05648      | 2    |
| 50   | m10454      | 1    |
| 51   | m09141      | 1    |

CZ DEFLEKTOR PRAVÝ  
 D DEFLEKTOR, RECHTER  
 F DÉFLECTEUR DROIT

GB DEFLECTOR RIGHT  
 RU ДЕФЛЕКТОР ПРАВЫЙ  
 PL DEFLEKTOR PRAWY



**VZ00029983**

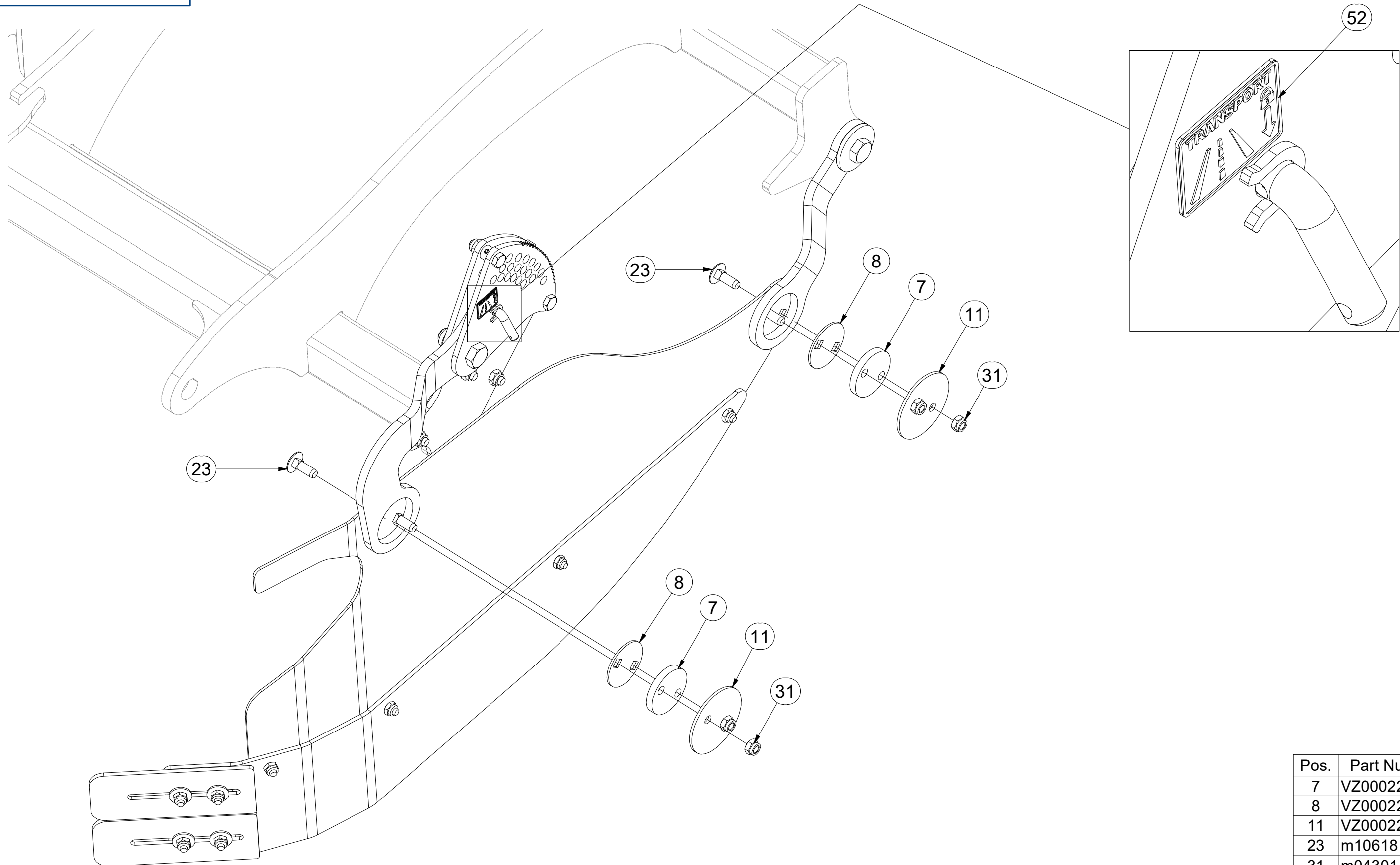

| Pos. | Part Number | Pcs. |
|------|-------------|------|
| 7    | VZ00022395  | 2    |
| 8    | VZ00022432  | 2    |
| 11   | VZ00022433  | 2    |
| 23   | m10618      | 7    |
| 31   | m04301      | 9    |
| 52   | m22872      | 1    |

- Ⓒ SADA ZADNÍCH VÁLČŮ
- Ⓓ SATZ HINTERE WALZEN
- Ⓕ KIT DE ROULEAUX ARRIÈRE

- Ⓖ SET OF REAR ROLLERS
- Ⓡ КОМПЛЕКТ ЗАДНИХ КАТКОВ
- Ⓟ ZESTAW TYLNYCH WAŁÓW



**VZ00018132**

| Pos. | Part Number | Pcs. |
|------|-------------|------|
| 1    | 2000759     | 2    |
| 2    | 2000760     | 1    |
| 3    | 3010651     | 2    |
| 4    | VZ00019231  | 1    |

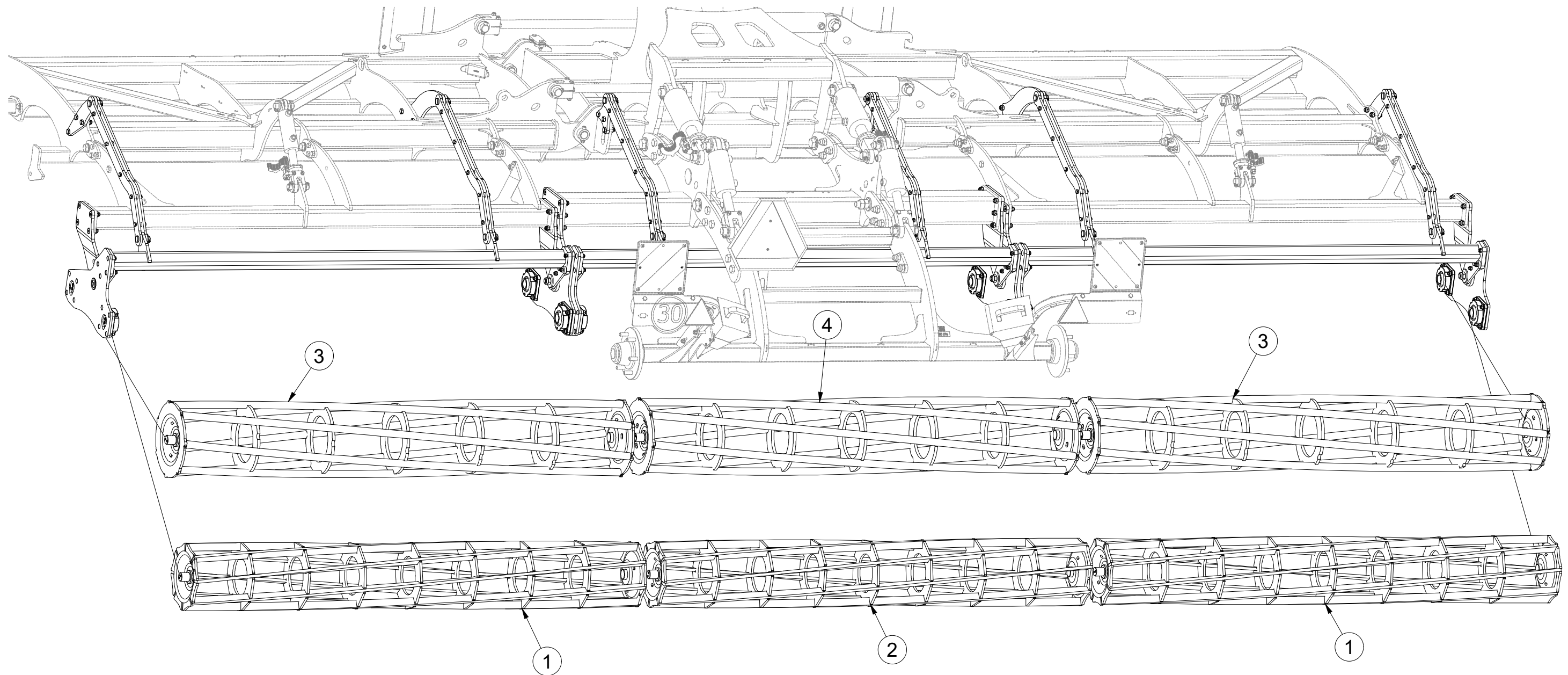
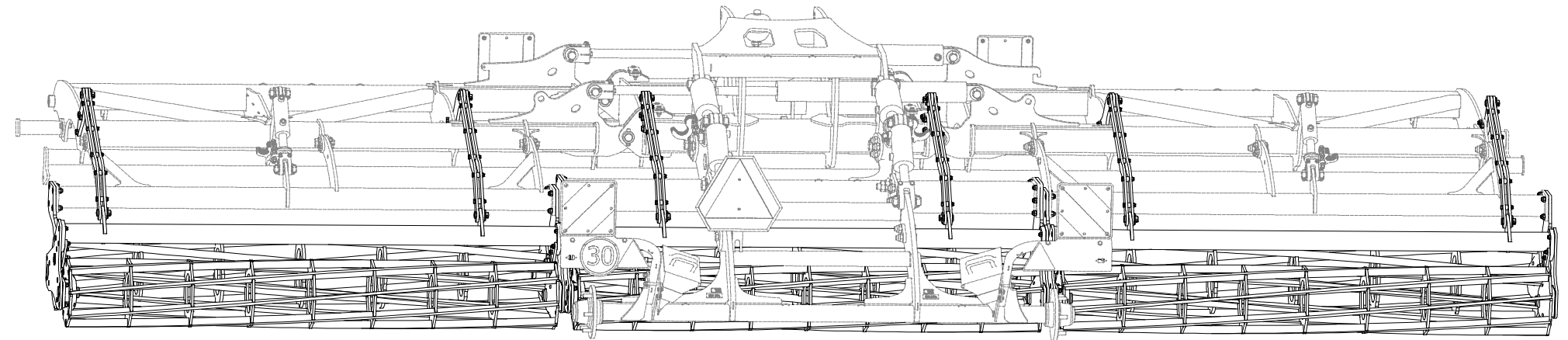

CZ SADA ZADNÍCH VÁLČŮ  
 D SATZ HINTERE WALZEN  
 F KIT DE ROULEAUX ARRIÈRE

GB SET OF REAR ROLLERS  
 RU КОМПЛЕКТ ЗАДНИХ КАТКОВ  
 PL ZESTAW TYLNYCH WAŁÓW



**VZ00018132**

| Pos. | Part Number | Pcs. | Pos. | Part Number | Pcs. |
|------|-------------|------|------|-------------|------|
| 5    | VZ00018145  | 1    | 26   | m14991      | 6    |
| 8    | 3008728     | 3    | 33   | m19364      | 6    |
| 9    | 3008729     | 3    | 34   | m19365      | 18   |
| 13   | 3008700     | 2    | 35   | m14672      | 28   |
| 14   | 3008702     | 2    | 37   | m14992      | 6    |
| 18   | 4015769     | 6    | 41   | m04301      | 24   |
| 21   | 4015792     | 6    | 43   | m03683      | 28   |
| 23   | VZ00003521  | 12   | 45   | m07147      | 6    |

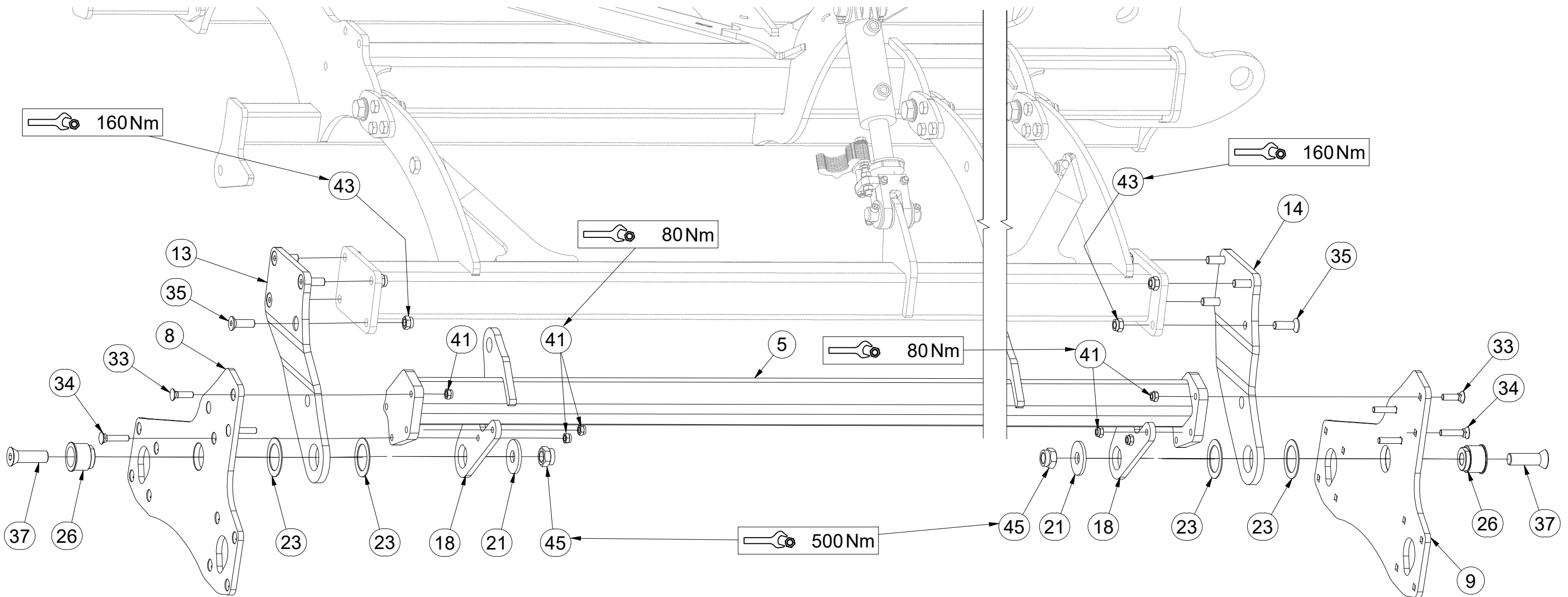
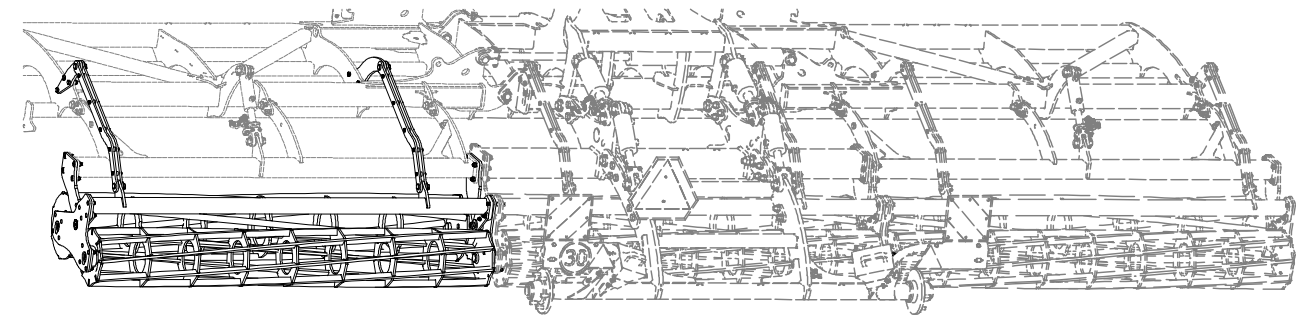

CZ SADA ZADNÍCH VÁLCŮ  
 D SATZ HINTERE WALZEN  
 F KIT DE ROULEAUX ARRIÈRE

GB SET OF REAR ROLLERS  
 RU КОМПЛЕКТ ЗАДНИХ КАТКОВ  
 PL ZESTAW TYLNYCH WAŁÓW



**VZ00018132**

| Pos. | Part Number | Pcs. | Pos. | Part Number | Pcs. |
|------|-------------|------|------|-------------|------|
| 6    | VZ00018146  | 1    | 26   | m14991      | 6    |
| 8    | 3008728     | 3    | 33   | m19364      | 6    |
| 9    | 3008729     | 3    | 34   | m19365      | 18   |
| 13   | 3008700     | 2    | 35   | m14672      | 28   |
| 14   | 3008702     | 2    | 37   | m14992      | 6    |
| 18   | 4015769     | 6    | 41   | m04301      | 24   |
| 21   | 4015792     | 6    | 43   | m03683      | 28   |
| 23   | VZ00003521  | 12   | 45   | m07147      | 6    |

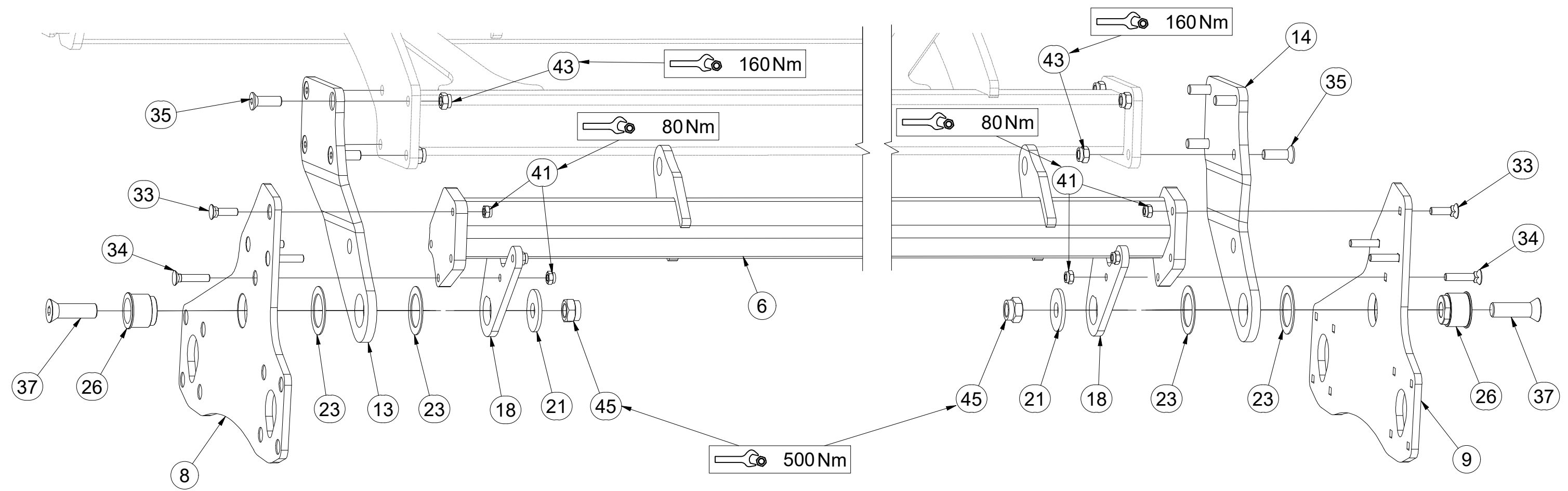
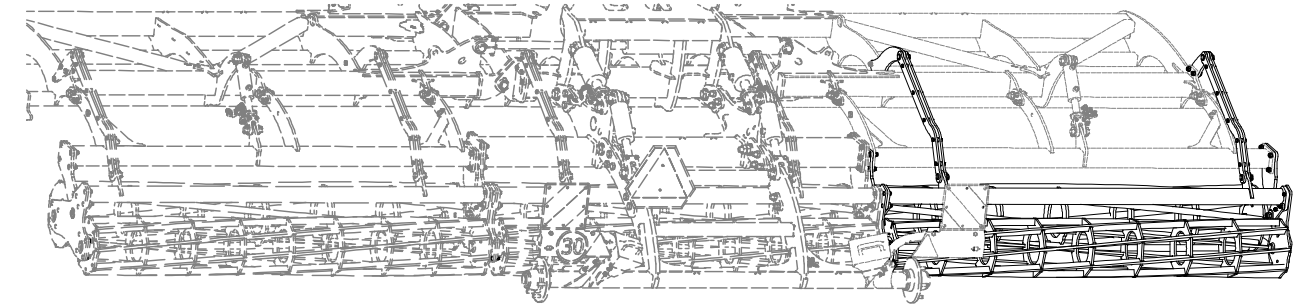

- Ⓒ SADA ZADNÍCH VÁLCŮ
- Ⓓ SATZ HINTERE WALZEN
- Ⓕ KIT DE ROULEAUX ARRIÈRE

- Ⓖ SET OF REAR ROLLERS
- Ⓡ КОМПЛЕКТ ЗАДНИХ КАТКОВ
- Ⓟ ZESTAW TYLNYCH WAŁÓW



**VZ00018132**

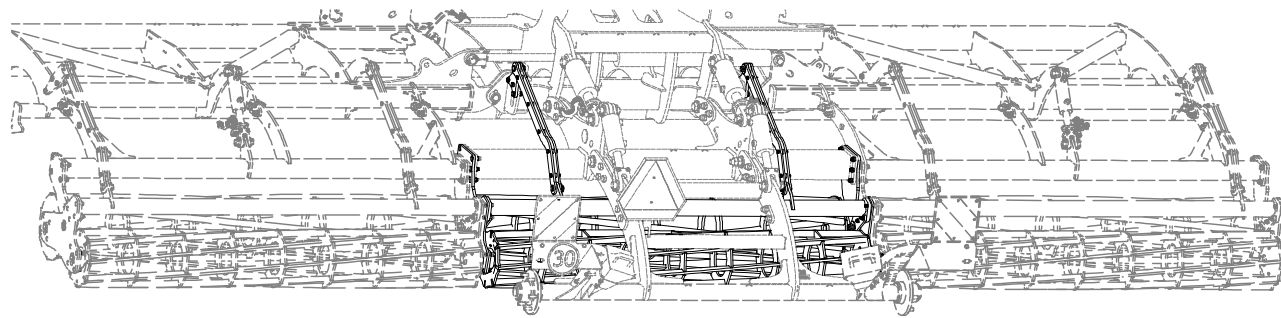

| Pos. | Part Number | Pcs. | Pos. | Part Number | Pcs. |
|------|-------------|------|------|-------------|------|
| 7    | VZ00018148  | 1    | 26   | m14991      | 6    |
| 8    | 3008728     | 3    | 33   | m19364      | 6    |
| 9    | 3008729     | 3    | 34   | m19365      | 18   |
| 11   | 3008717     | 1    | 35   | m14672      | 28   |
| 12   | 3008718     | 1    | 37   | m14992      | 6    |
| 18   | 4015769     | 6    | 41   | m04301      | 24   |
| 21   | 4015792     | 6    | 43   | m03683      | 28   |
| 23   | VZ00003521  | 12   | 45   | m07147      | 6    |

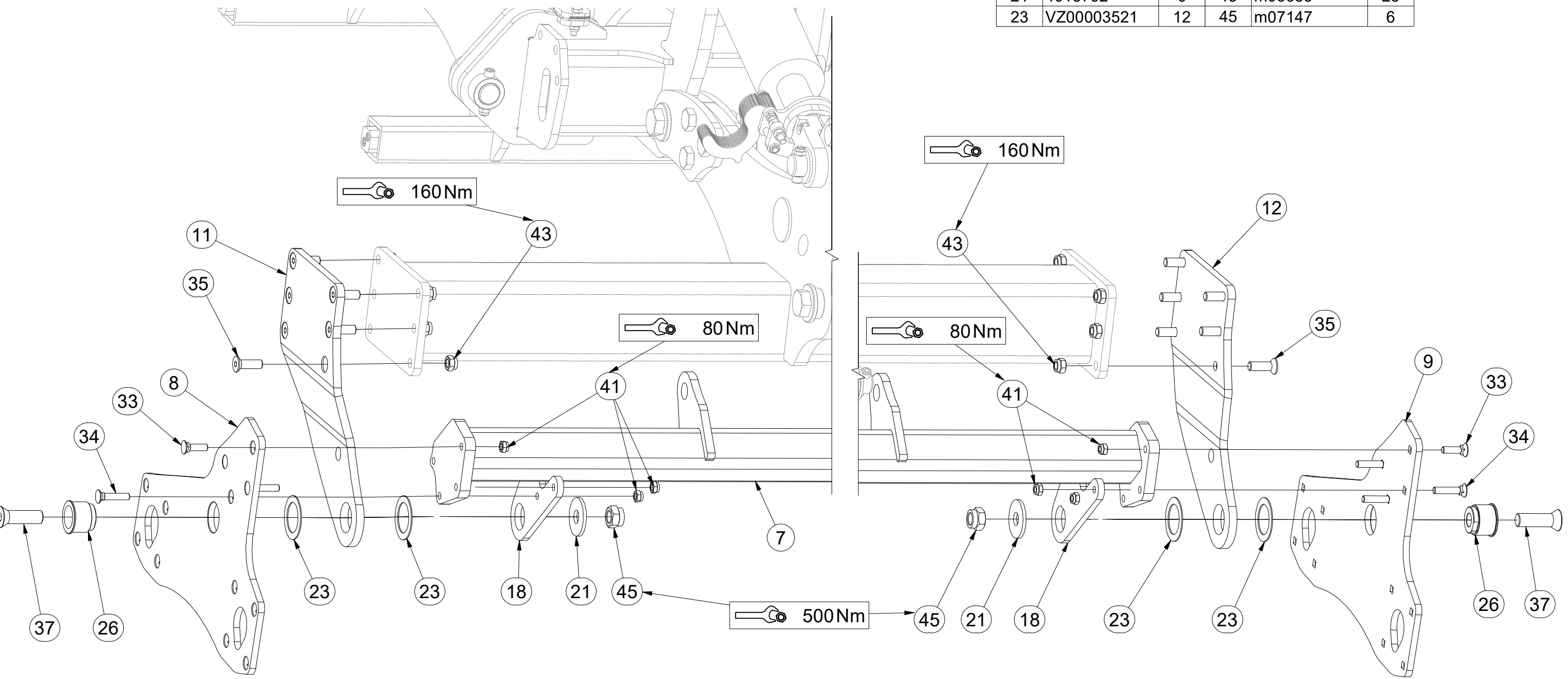

CZ SADA ZADNÍCH VÁLCŮ  
 D SATZ HINTERE WALZEN  
 F KIT DE ROULEAUX ARRIÈRE

GB SET OF REAR ROLLERS  
 RU КОМПЛЕКТ ЗАДНИХ КАТКОВ  
 PL ZESTAW TYLNYCH WAŁÓW



**VZ00018132**

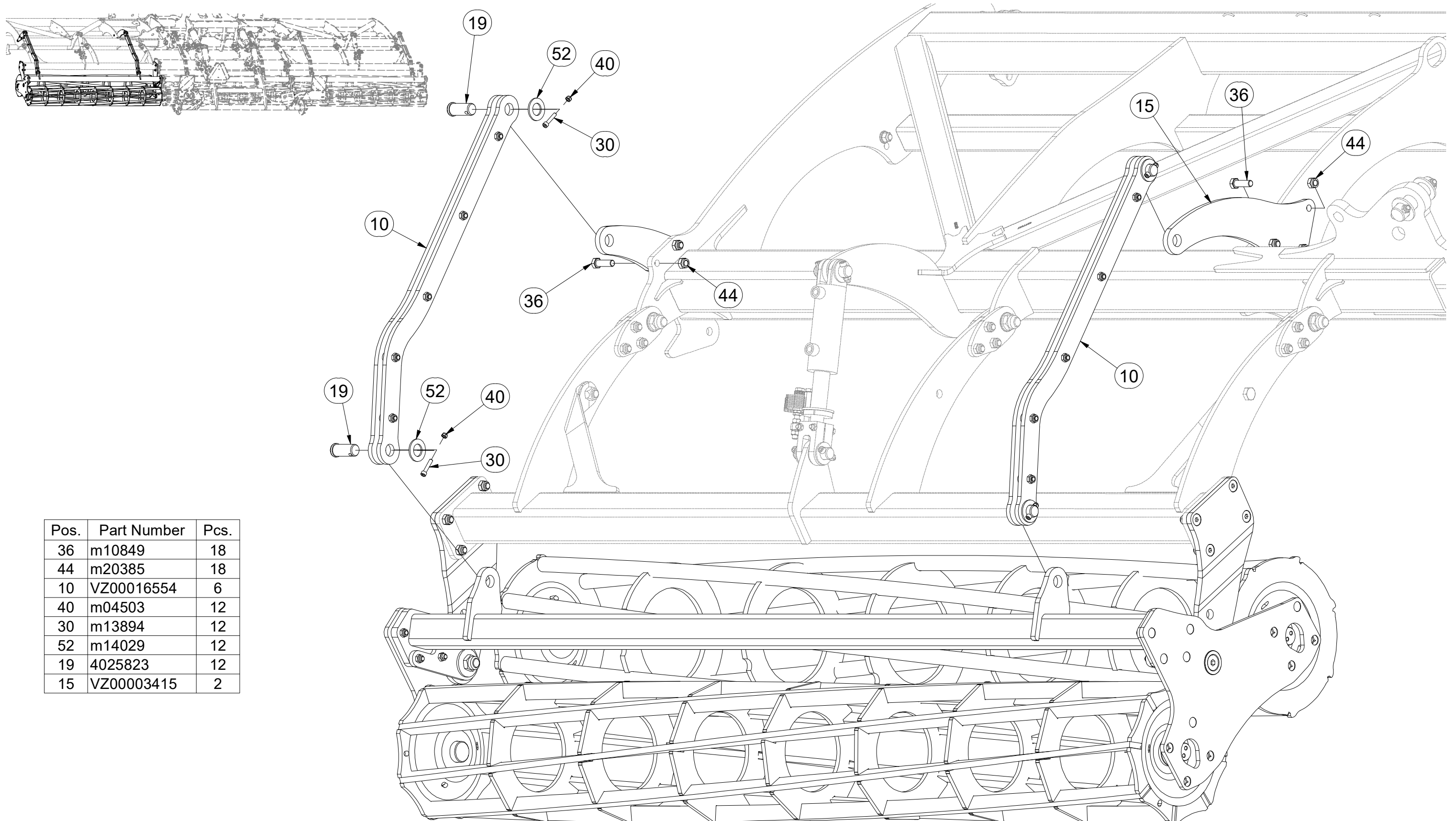

| Pos. | Part Number | Pcs. |
|------|-------------|------|
| 36   | m10849      | 18   |
| 44   | m20385      | 18   |
| 10   | VZ00016554  | 6    |
| 40   | m04503      | 12   |
| 30   | m13894      | 12   |
| 52   | m14029      | 12   |
| 19   | 4025823     | 12   |
| 15   | VZ00003415  | 2    |



CZ SADA ZADNÍCH VÁLCŮ  
 D SATZ HINTERE WALZEN  
 F KIT DE ROULEAUX ARRIÈRE

GB SET OF REAR ROLLERS  
 RU КОМПЛЕКТ ЗАДНИХ КАТКОВ  
 PL ZESTAW TYLNYCH WAŁÓW



**VZ00018132**

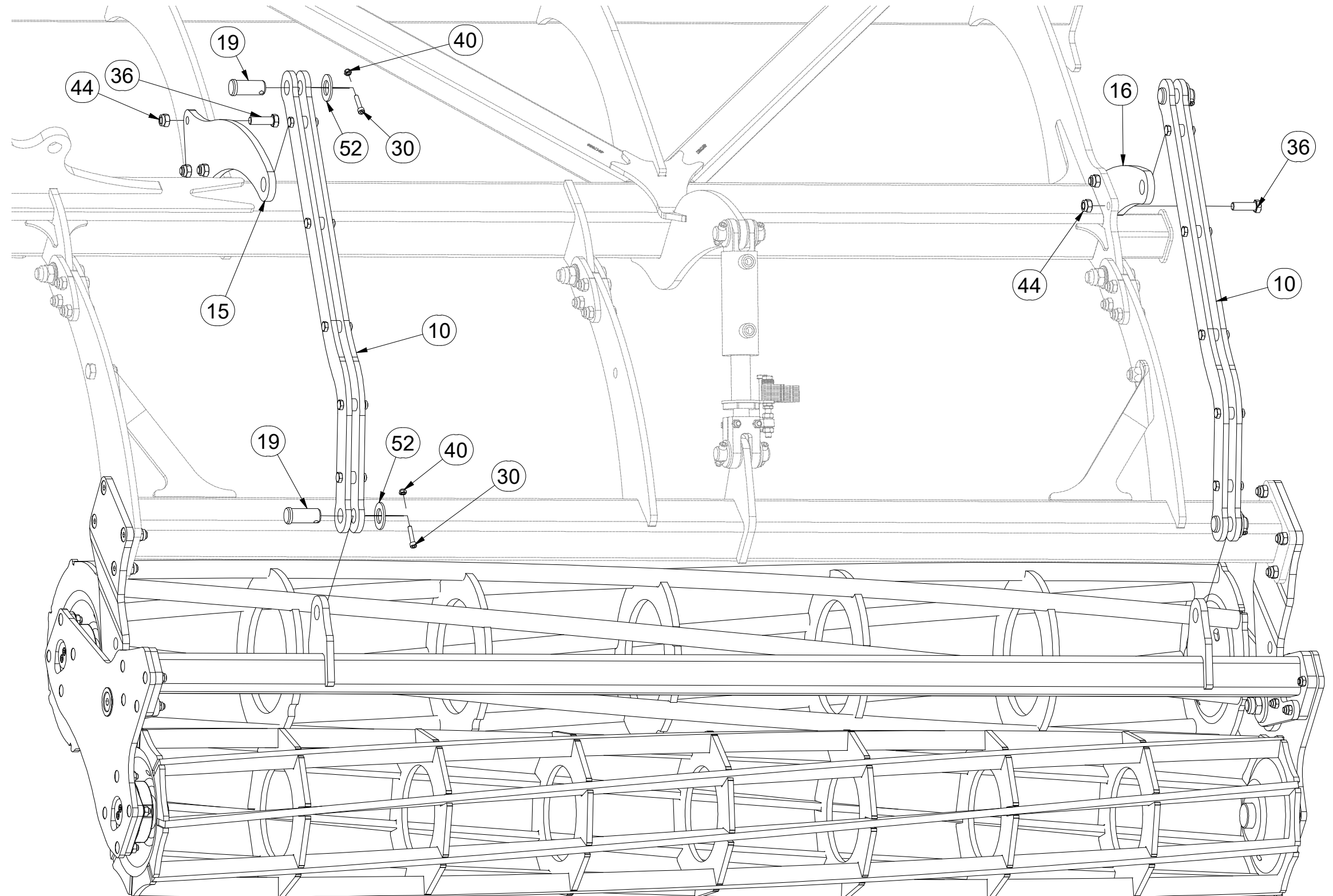
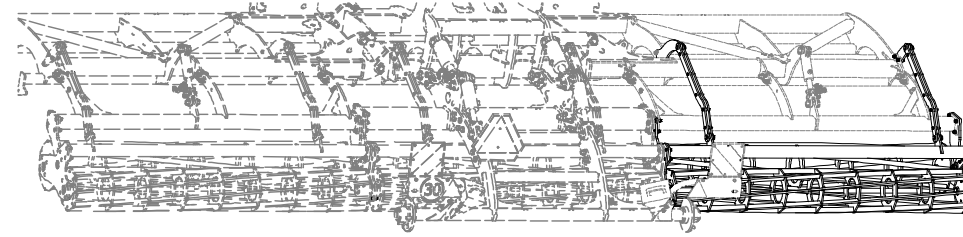

| Pos. | Part Number | Pcs. |
|------|-------------|------|
| 10   | VZ00016554  | 6    |
| 15   | VZ00003415  | 2    |
| 16   | VZ00003423  | 2    |
| 19   | 4025823     | 12   |
| 30   | m13894      | 12   |
| 36   | m10849      | 18   |
| 40   | m04503      | 12   |
| 44   | m20385      | 18   |
| 52   | m14029      | 12   |

CZ SADA ZADNÍCH VÁLČŮ  
 D SATZ HINTERE WALZEN  
 F KIT DE ROULEAUX ARRIÈRE

GB SET OF REAR ROLLERS  
 RU КОМПЛЕКТ ЗАДНИХ КАТКОВ  
 PL ZESTAW TYLNYCH WAŁÓW



**VZ00018132**

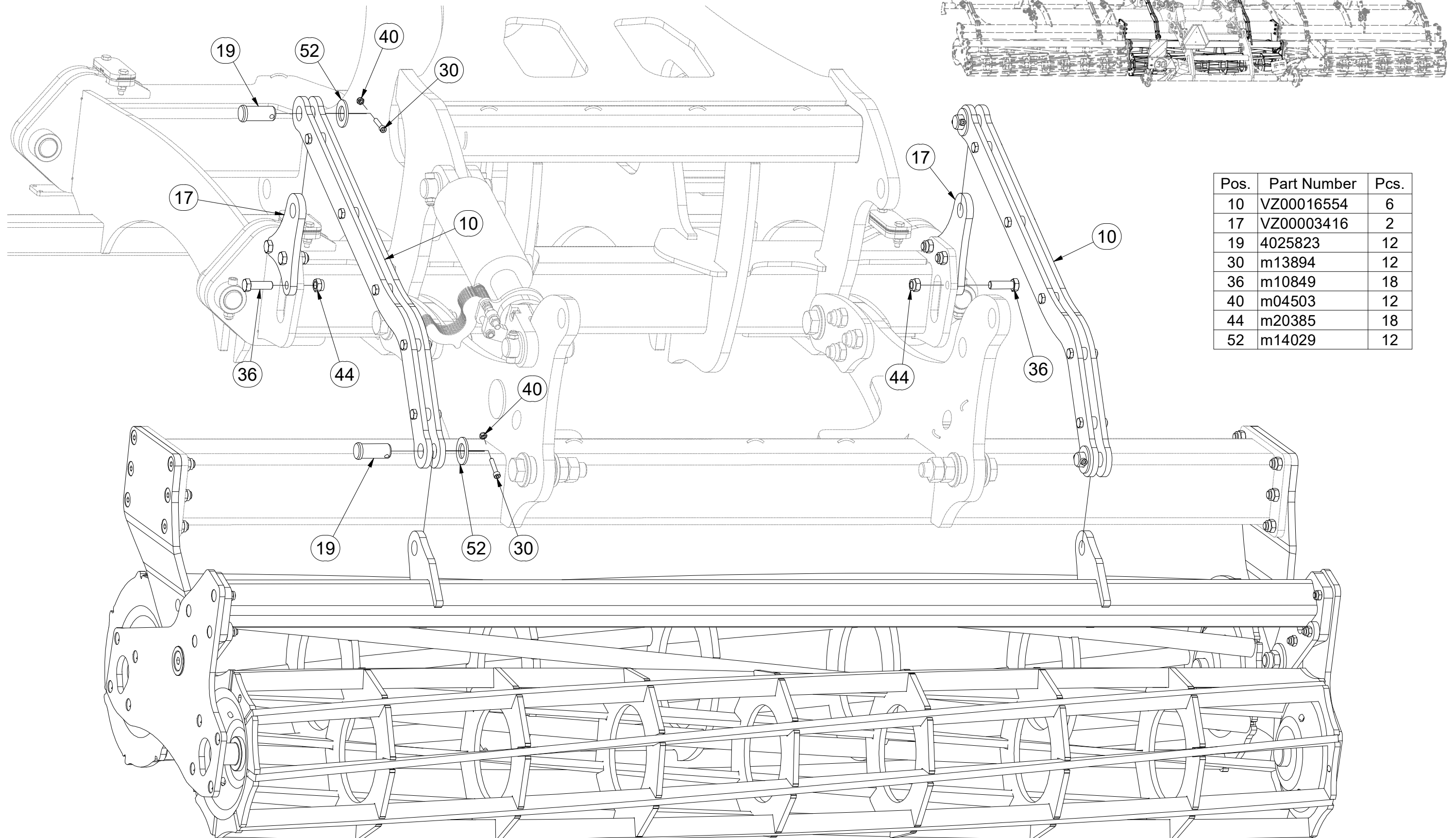

| Pos. | Part Number | Pcs. |
|------|-------------|------|
| 10   | VZ00016554  | 6    |
| 17   | VZ00003416  | 2    |
| 19   | 4025823     | 12   |
| 30   | m13894      | 12   |
| 36   | m10849      | 18   |
| 40   | m04503      | 12   |
| 44   | m20385      | 18   |
| 52   | m14029      | 12   |

- Ⓒ SADA ZADNÍCH VÁLCŮ
- Ⓓ SATZ HINTERE WALZEN
- Ⓕ KIT DE ROULEAUX ARRIÈRE

- Ⓖ SET OF REAR ROLLERS
- Ⓡ КОМПЛЕКТ ЗАДНИХ КАТКОВ
- Ⓟ ZESTAW TYLNYCH WAŁÓW



**VZ00018132**

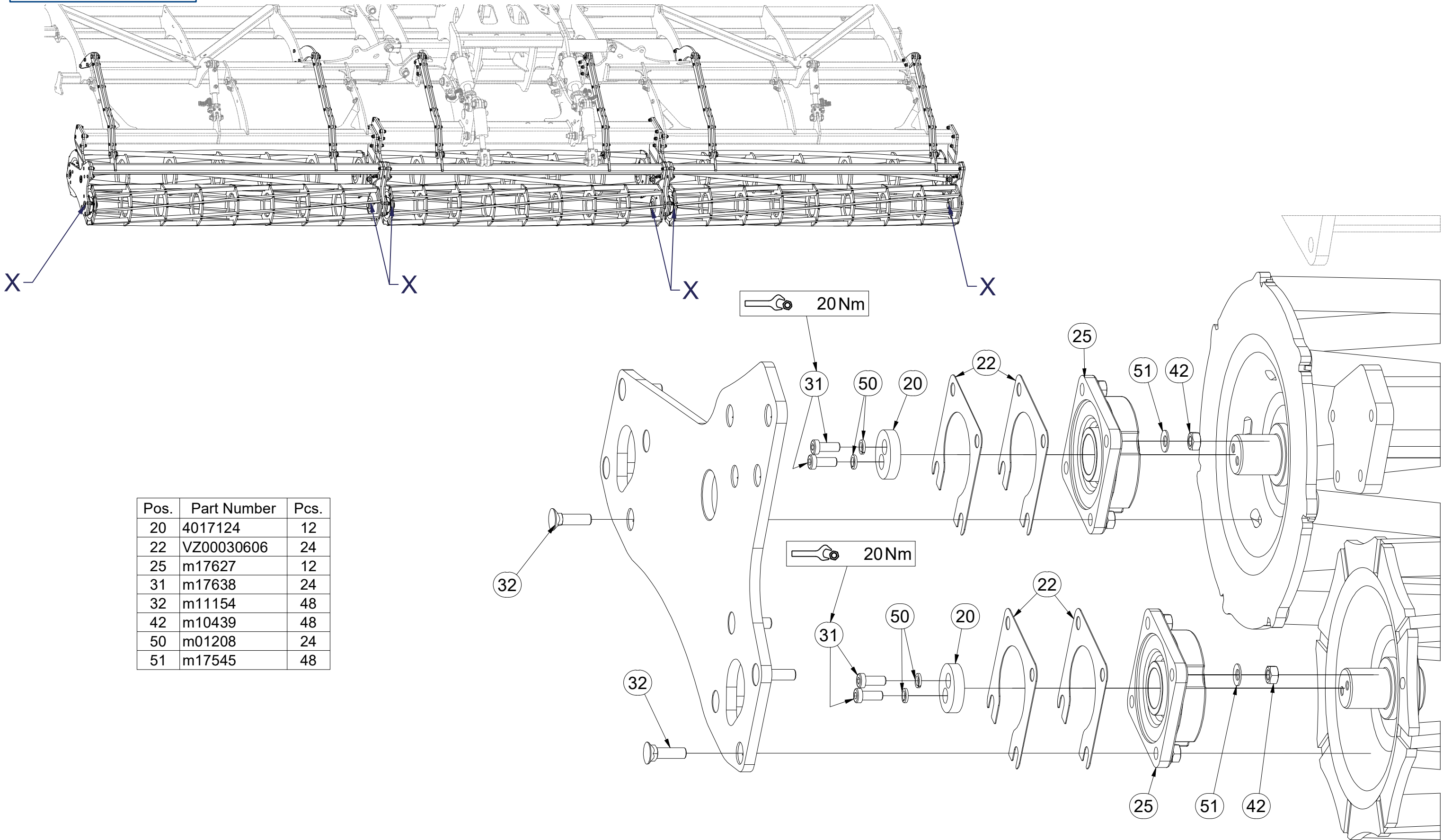

| Pos. | Part Number | Pcs. |
|------|-------------|------|
| 20   | 4017124     | 12   |
| 22   | VZ00030606  | 24   |
| 25   | m17627      | 12   |
| 31   | m17638      | 24   |
| 32   | m11154      | 48   |
| 42   | m10439      | 48   |
| 50   | m01208      | 24   |
| 51   | m17545      | 48   |

CZ TÁHLO  
 D STANGE  
 F TIGE DE TRACTION

GB DRAWBAR  
 RU ТЯГА  
 PL PRĘT



**VZ00016554**

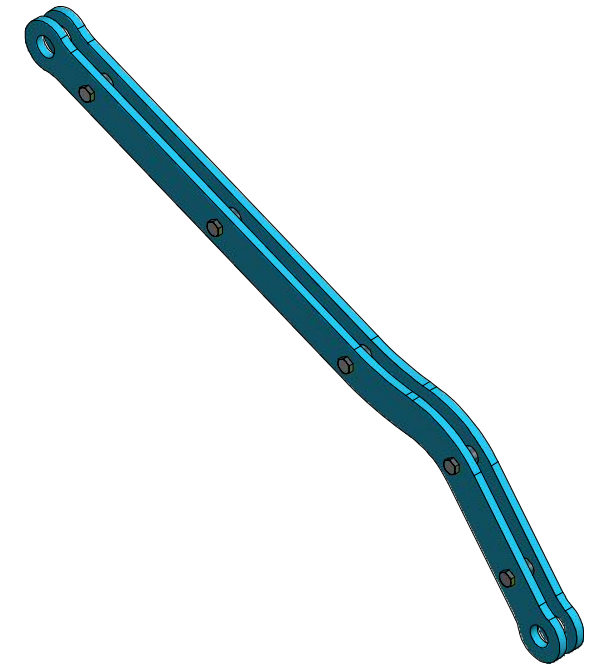
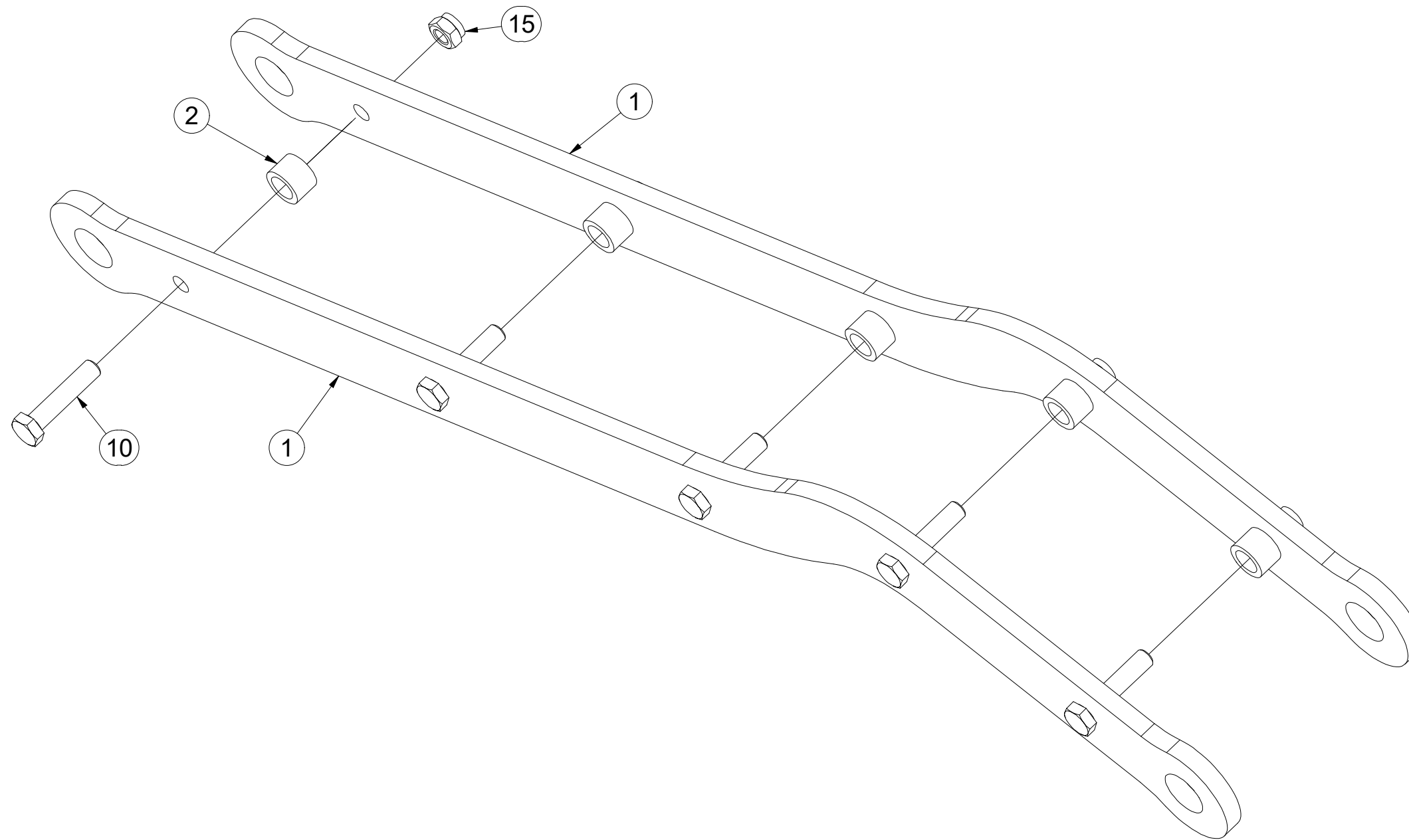

| Pos. | Part Number | Pcs. |
|------|-------------|------|
| 1    | VZ00016555  | 2    |
| 2    | 4006690     | 5    |
| 10   | m04412      | 5    |
| 15   | m04301      | 5    |

- Ⓒ SADA NÁPRAVY
- Ⓓ SATZ AUFHÄNGUNG
- Ⓕ KIT DE L'ESSIEU

- Ⓖ AXLE SET
- Ⓡ КОМПЛЕКТ ОСИ КОЛЁС
- Ⓟ ZESTAW OSI



**VZ00018117**

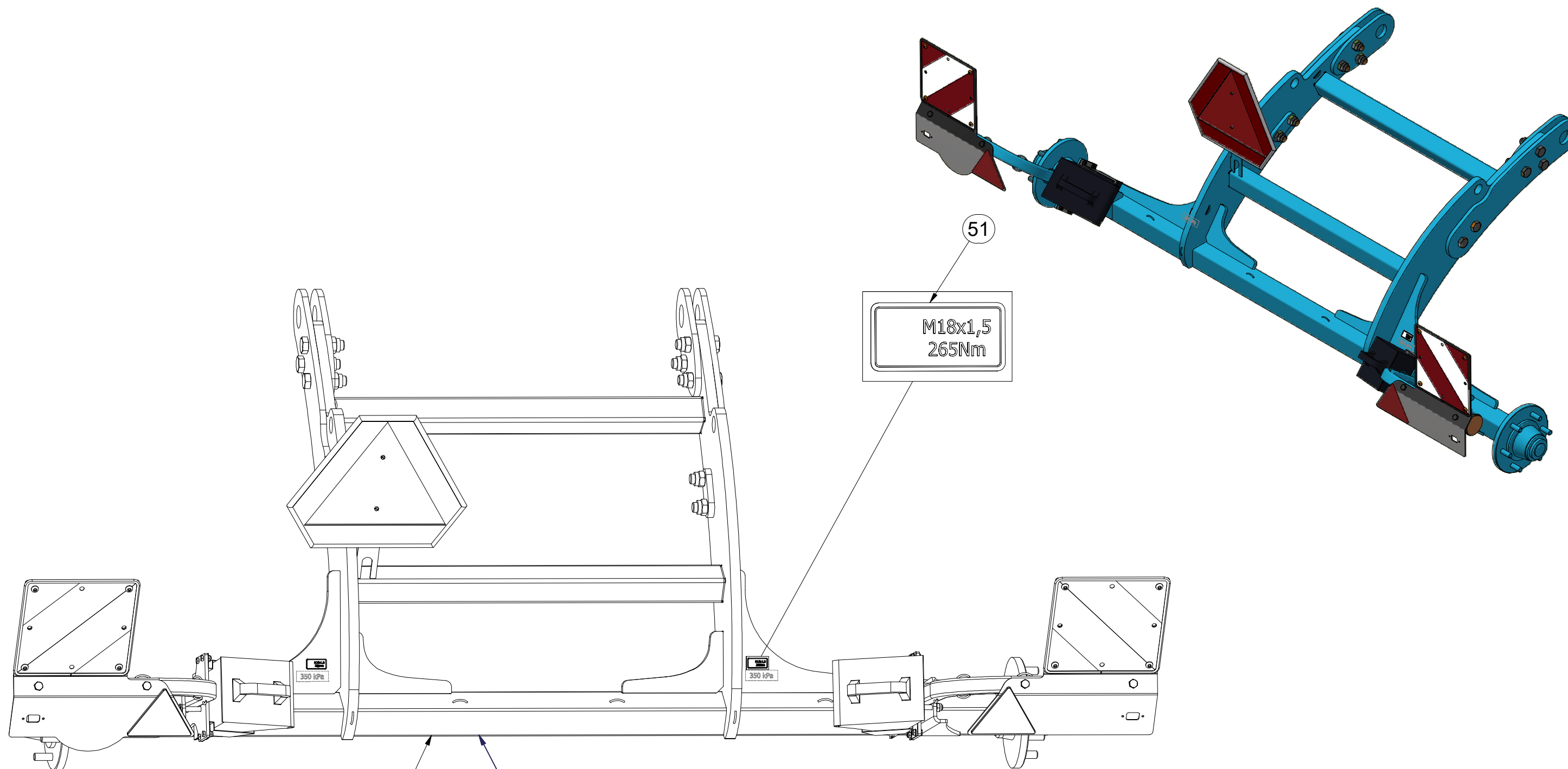

**A80RM600**

| Pos. | Part Number | Pcs. |
|------|-------------|------|
| 1    | 2001187     | 1    |
| 51   | m19732      | 2    |

Ⓒ SADA NÁPRAVY

Ⓓ SATZ AUFHÄNGUNG

Ⓕ KIT DE L'ESSIEU

**VZ00018117**

Ⓖ AXLE SET

Ⓡ КОМПЛЕКТ ОСИ КОЛЁС

Ⓢ ZESTAW OSI

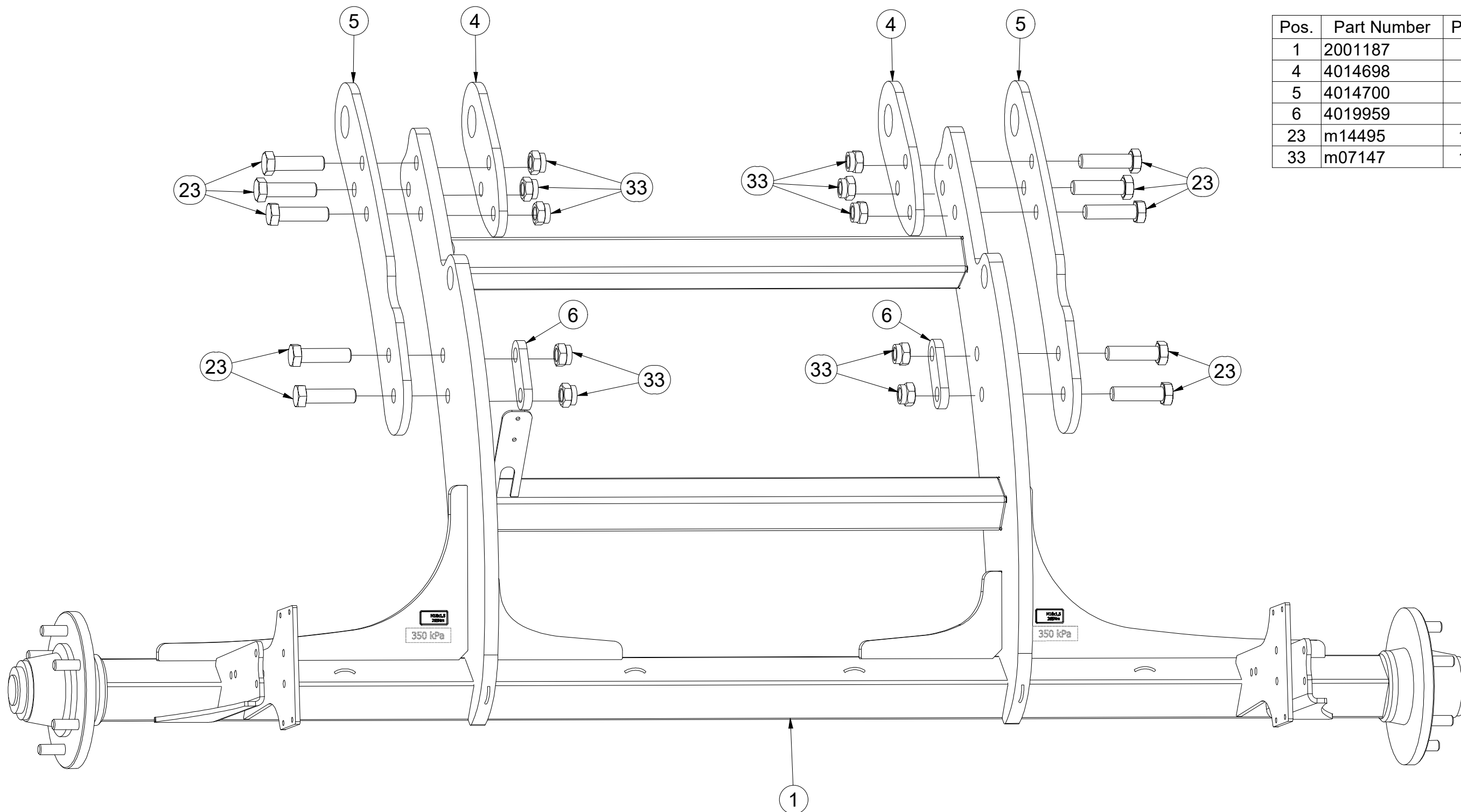

| Pos. | Part Number | Pcs. |
|------|-------------|------|
| 1    | 2001187     | 1    |
| 4    | 4014698     | 2    |
| 5    | 4014700     | 2    |
| 6    | 4019959     | 2    |
| 23   | m14495      | 10   |
| 33   | m07147      | 10   |

Ⓒ SADA NÁPRAVY

Ⓓ SATZ AUFHÄNGUNG

Ⓕ KIT DE L'ESSIEU

Ⓖ AXLE SET

Ⓡ КОМПЛЕКТ ОСИ КОЛЁС

Ⓢ ZESTAW OSI



**VZ00018117**

| Pos. | Part Number | Pcs. |
|------|-------------|------|
| 1    | 2001187     | 1    |
| 2    | 3012367     | 1    |
| 21   | m01089      | 8    |
| 22   | m12493      | 6    |
| 31   | m04503      | 8    |
| 32   | m04301      | 6    |
| 36   | m01203      | 8    |
| 37   | m01214      | 6    |
| 40   | m16186      | 2    |
| 41   | m12572      | 2    |

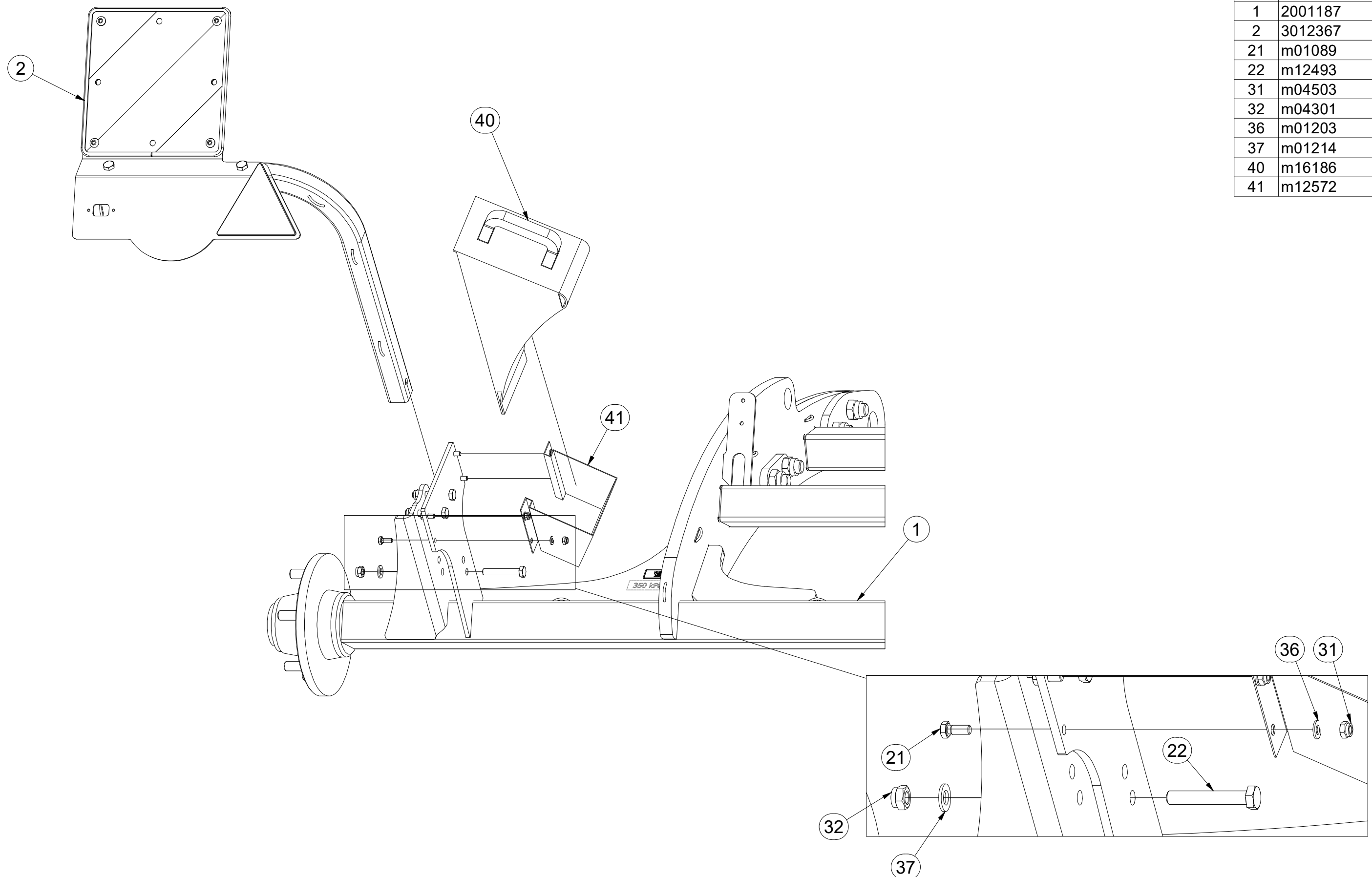

Ⓒ SADA NÁPRAVY

Ⓓ SATZ AUFHÄNGUNG

Ⓕ KIT DE L'ESSIEU

Ⓖ AXLE SET

Ⓡ КОМПЛЕКТ ОСИ КОЛЁС

Ⓢ ZESTAW OSI



**VZ00018117**

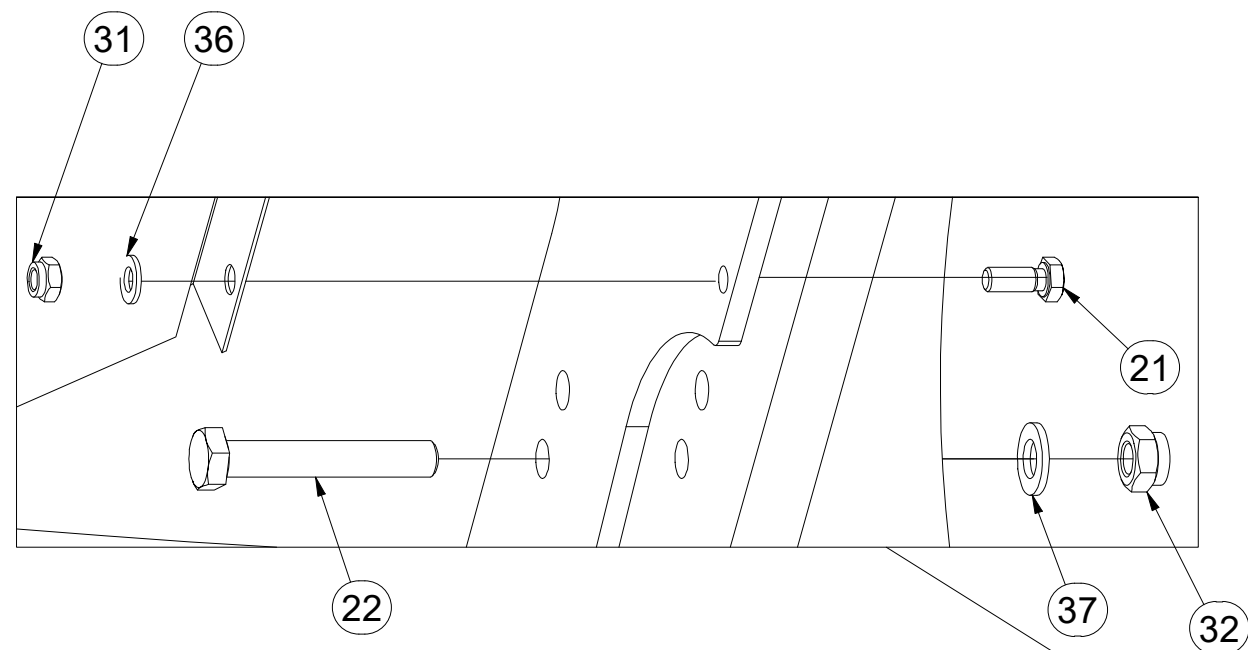

| Pos. | Part Number | Pcs. |
|------|-------------|------|
| 1    | 2001187     | 1    |
| 3    | 3012389     | 1    |
| 21   | m01089      | 8    |
| 22   | m12493      | 6    |
| 31   | m04503      | 8    |
| 32   | m04301      | 6    |
| 36   | m01203      | 8    |
| 37   | m01214      | 6    |
| 40   | m16186      | 2    |
| 41   | m12572      | 2    |

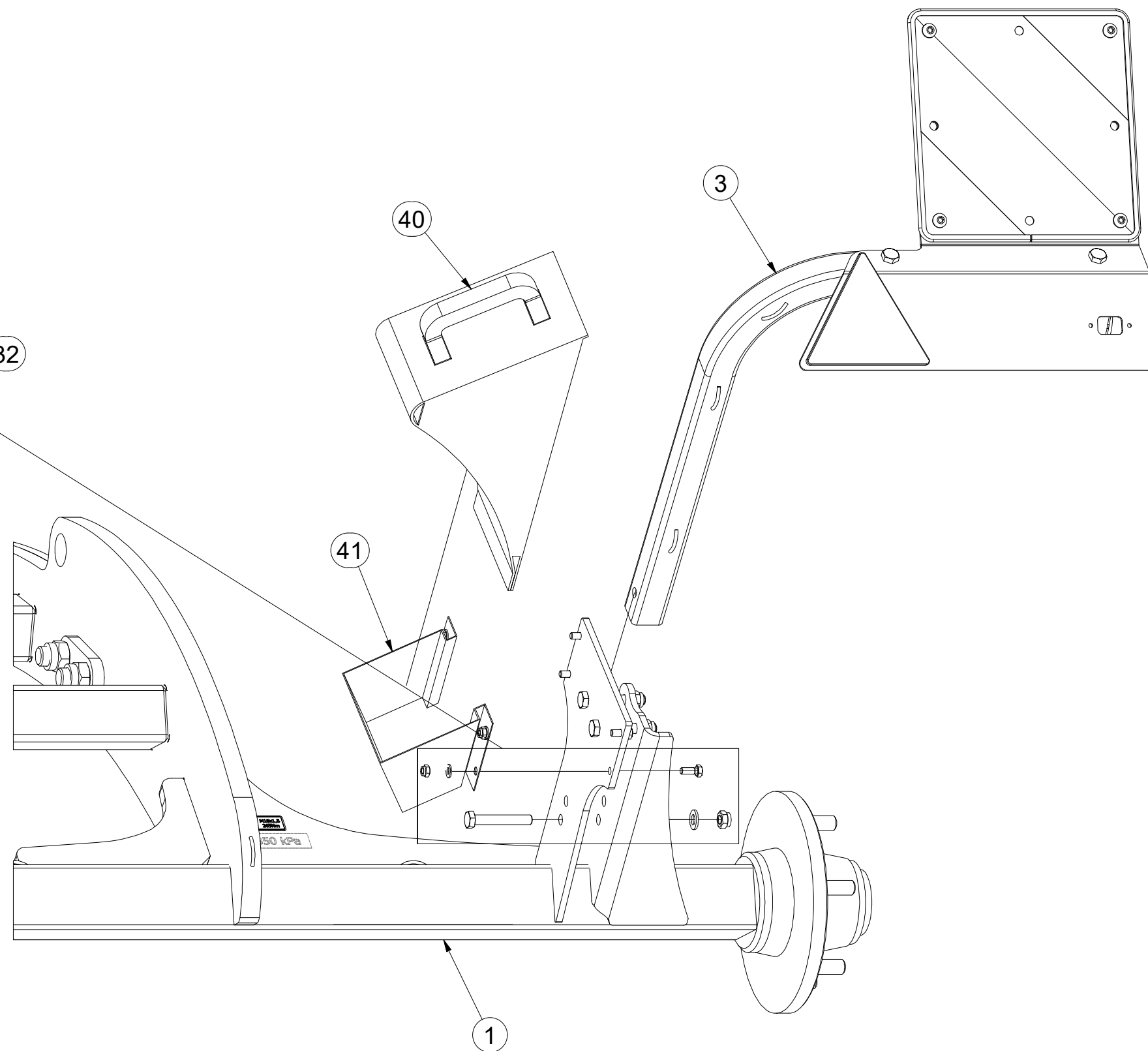



Ⓒ SADA NÁPRAVY

Ⓓ SATZ AUFHÄNGUNG

Ⓕ KIT DE L'ESSIEU

**VZ00018117**

Ⓖ AXLE SET

Ⓡ КОМПЛЕКТ ОСИ КОЛЁС

Ⓢ ZESTAW OSI

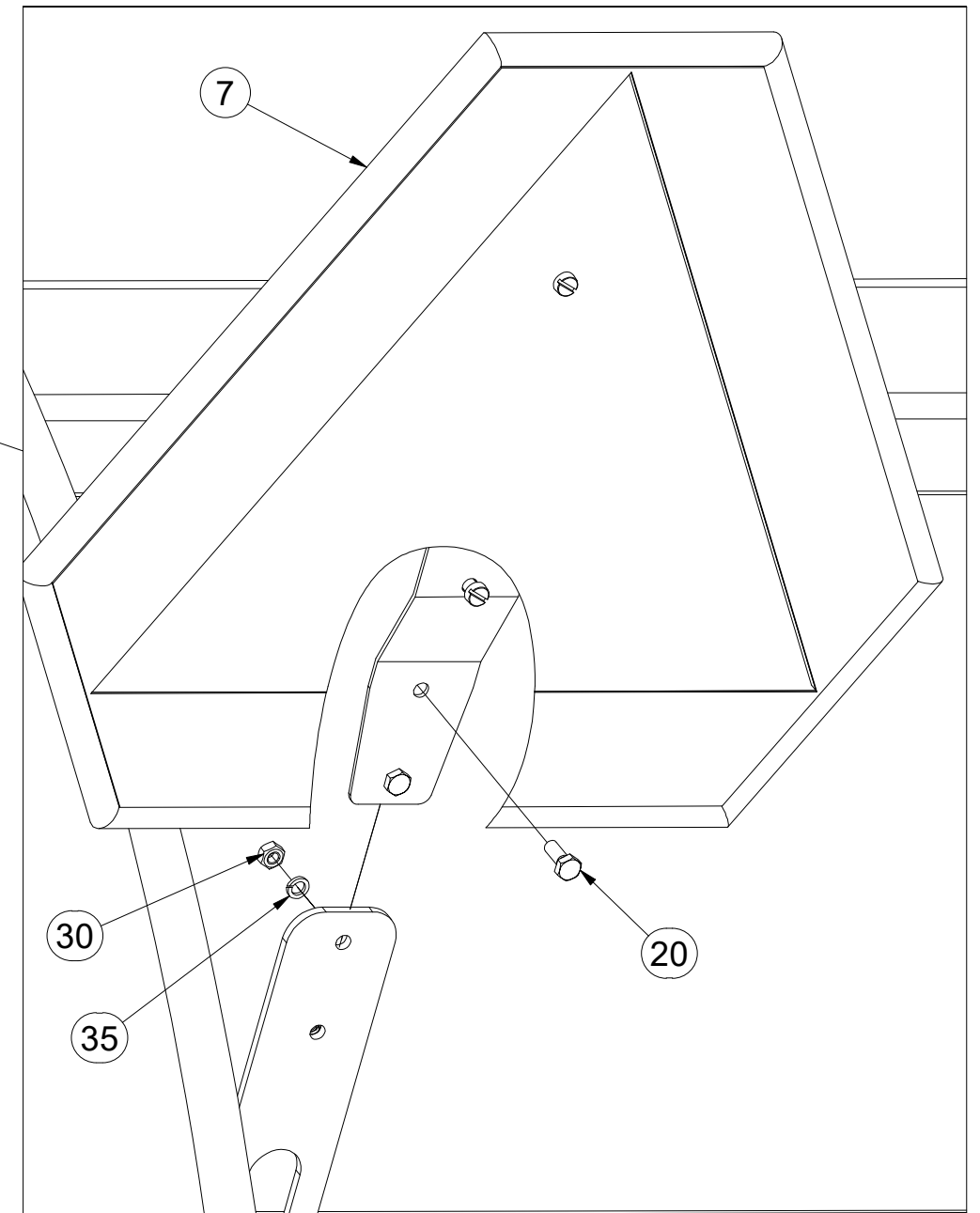
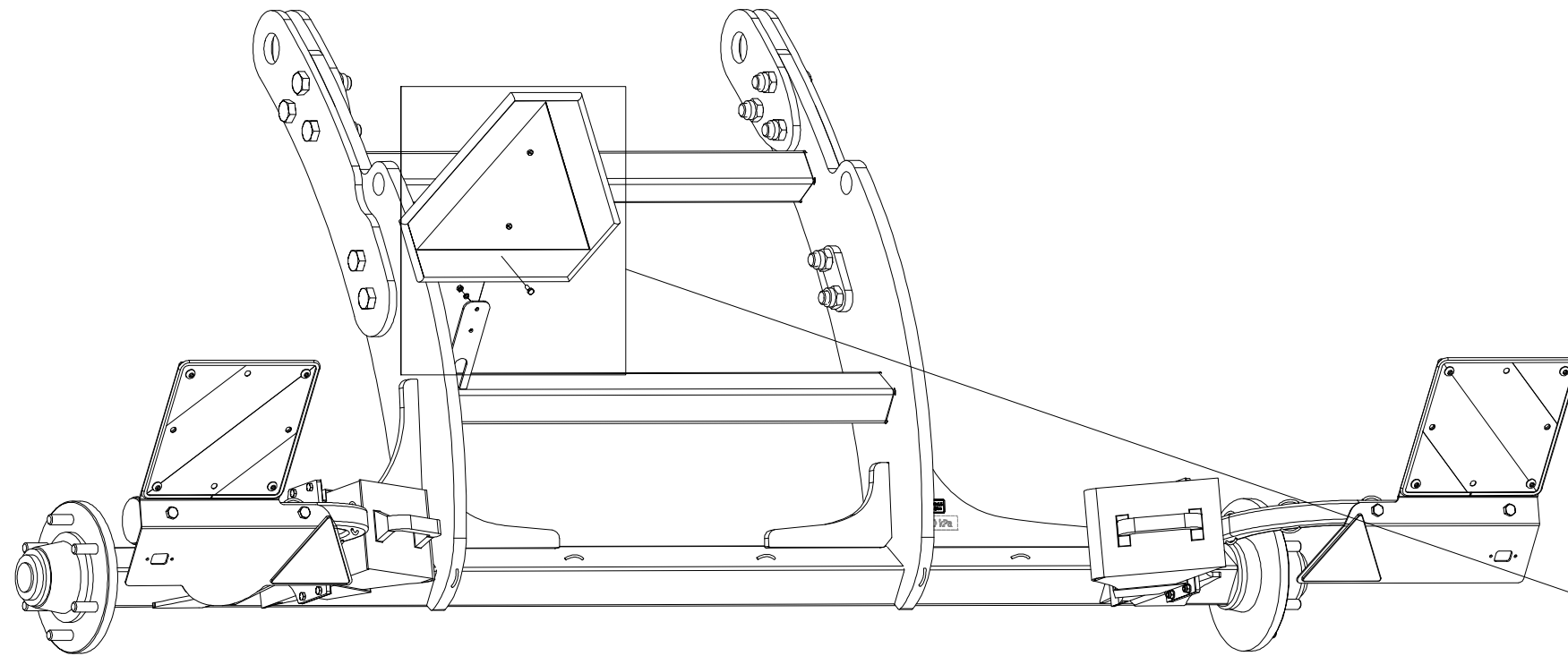

| Pos. | Part Number | Pcs. |
|------|-------------|------|
| 7    | 4007398     | 1    |
| 20   | m01073      | 2    |
| 30   | m01295      | 2    |
| 35   | m01200      | 2    |

Ⓒ NÁPRAVA

Ⓓ ACHSE

Ⓕ ESSIEU

Ⓒ AXLE

Ⓓ OCB

Ⓕ OS



**A80RM600**

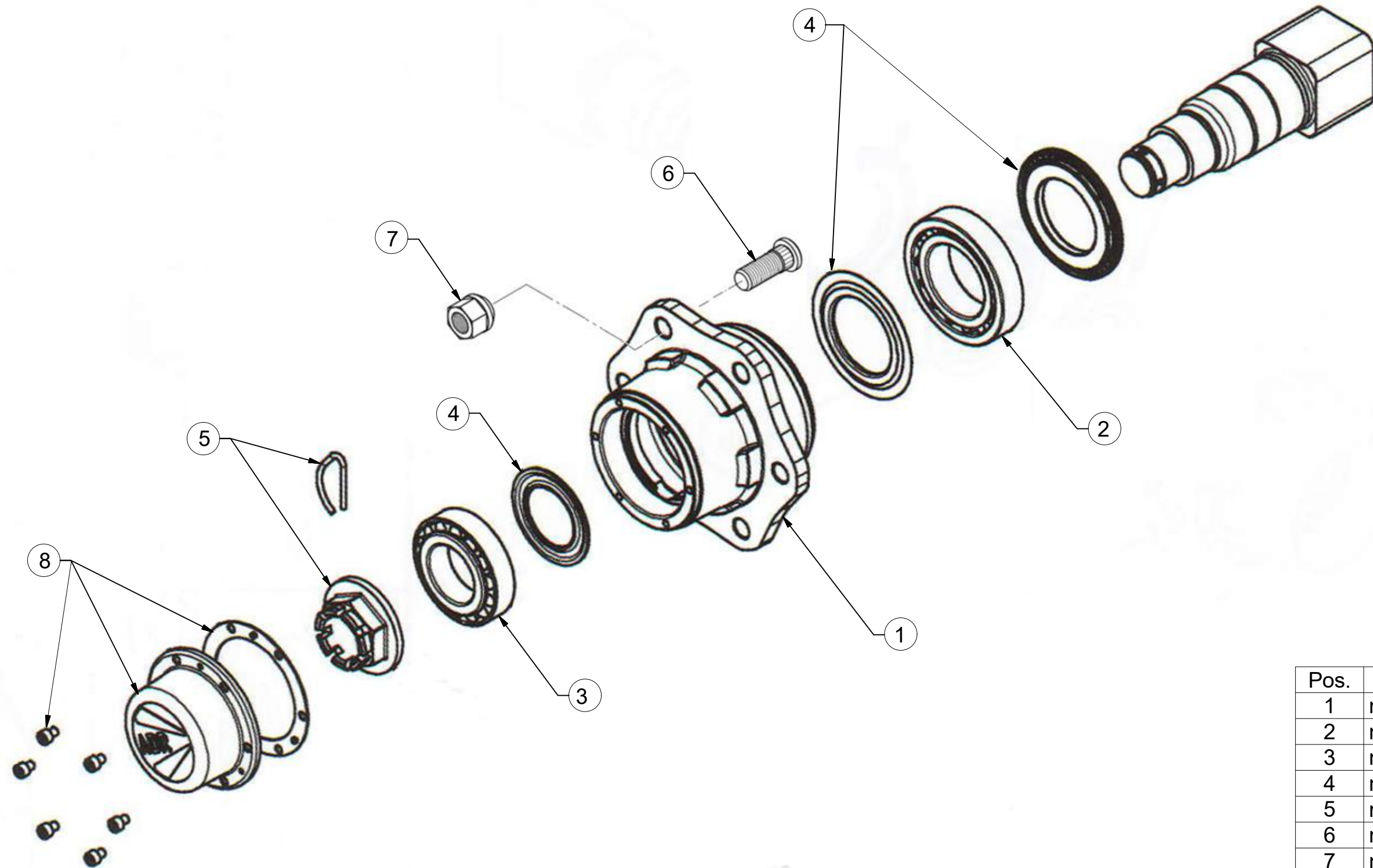

| Pos. | Part Number | Pcs. |
|------|-------------|------|
| 1    | m12567      | 2    |
| 2    | m07153      | 2    |
| 3    | m07154      | 2    |
| 4    | m12565      | 2    |
| 5    | m08168      | 2    |
| 6    | m08148      | 12   |
| 7    | m08163      | 12   |
| 8    | m12566      | 2    |

Ⓒ SADA NÁPRAVY

Ⓓ SATZ AUFHÄNGUNG

Ⓕ KIT DE L'ESSIEU

**VZ00018118**

Ⓖ AXLE SET

Ⓡ КОМПЛЕКТ ОСИ КОЛЁС

Ⓢ ZESTAW OSI

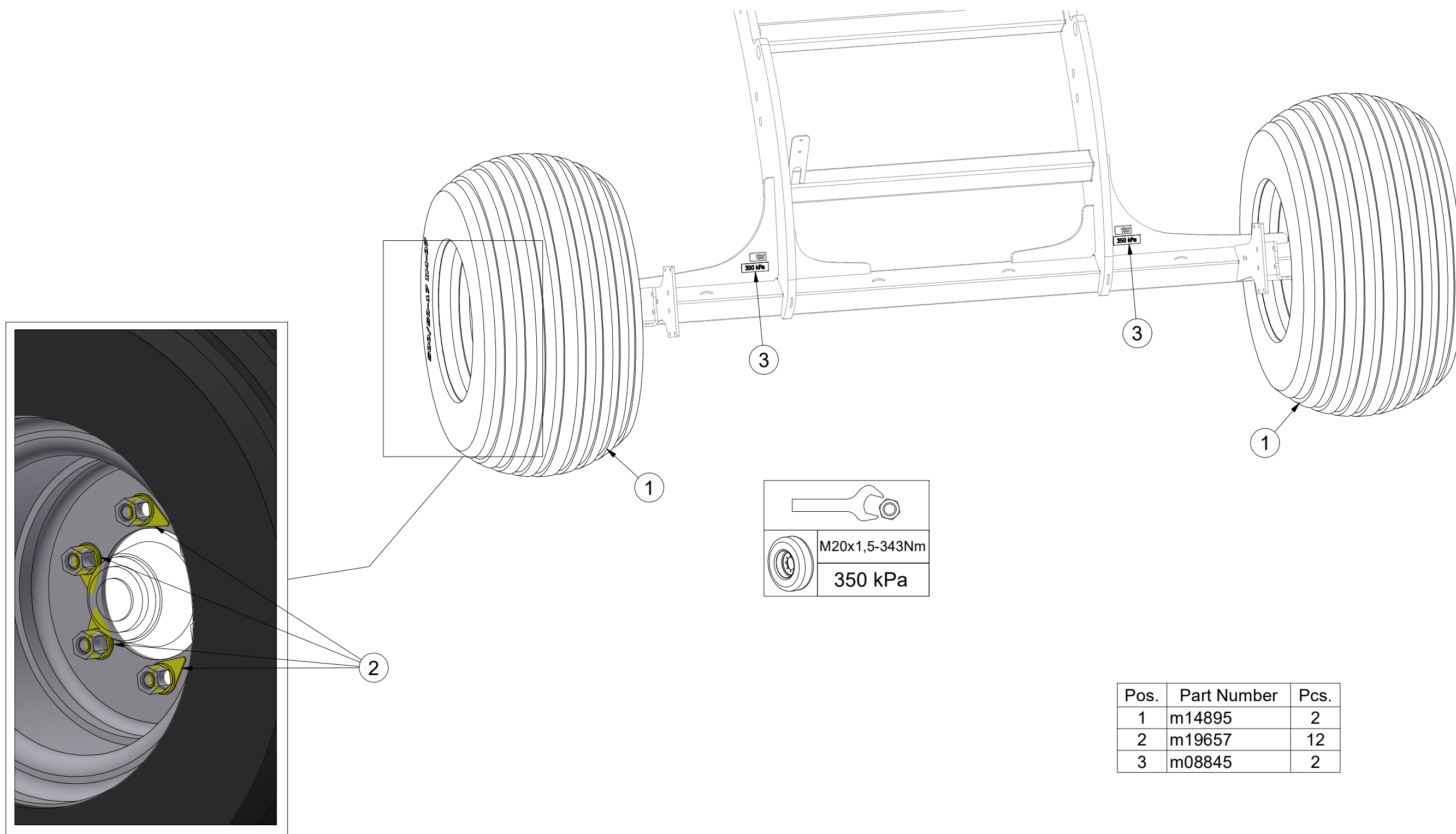

| Pos. | Part Number | Pcs. |
|------|-------------|------|
| 1    | m14895      | 2    |
| 2    | m19657      | 12   |
| 3    | m08845      | 2    |

ⒸZ TERČ ZADNÍ LEVÝ

Ⓓ SCHILD, HINTERES, LINKES

Ⓕ CIBLE ARRIÈRE GAUCHE

**3012367**

ⒼB LEFT REAR DISC

ⒺЩИТОК ЗАДНИЙ ЛЕВЫЙ

ⒽL TARCZA TYLNA LEWA

**Farmet**

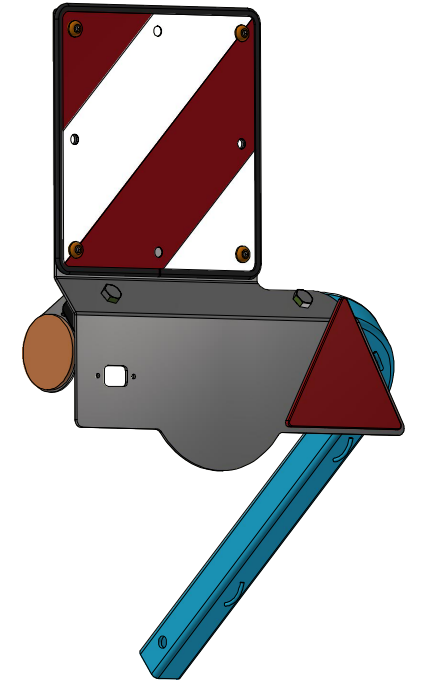
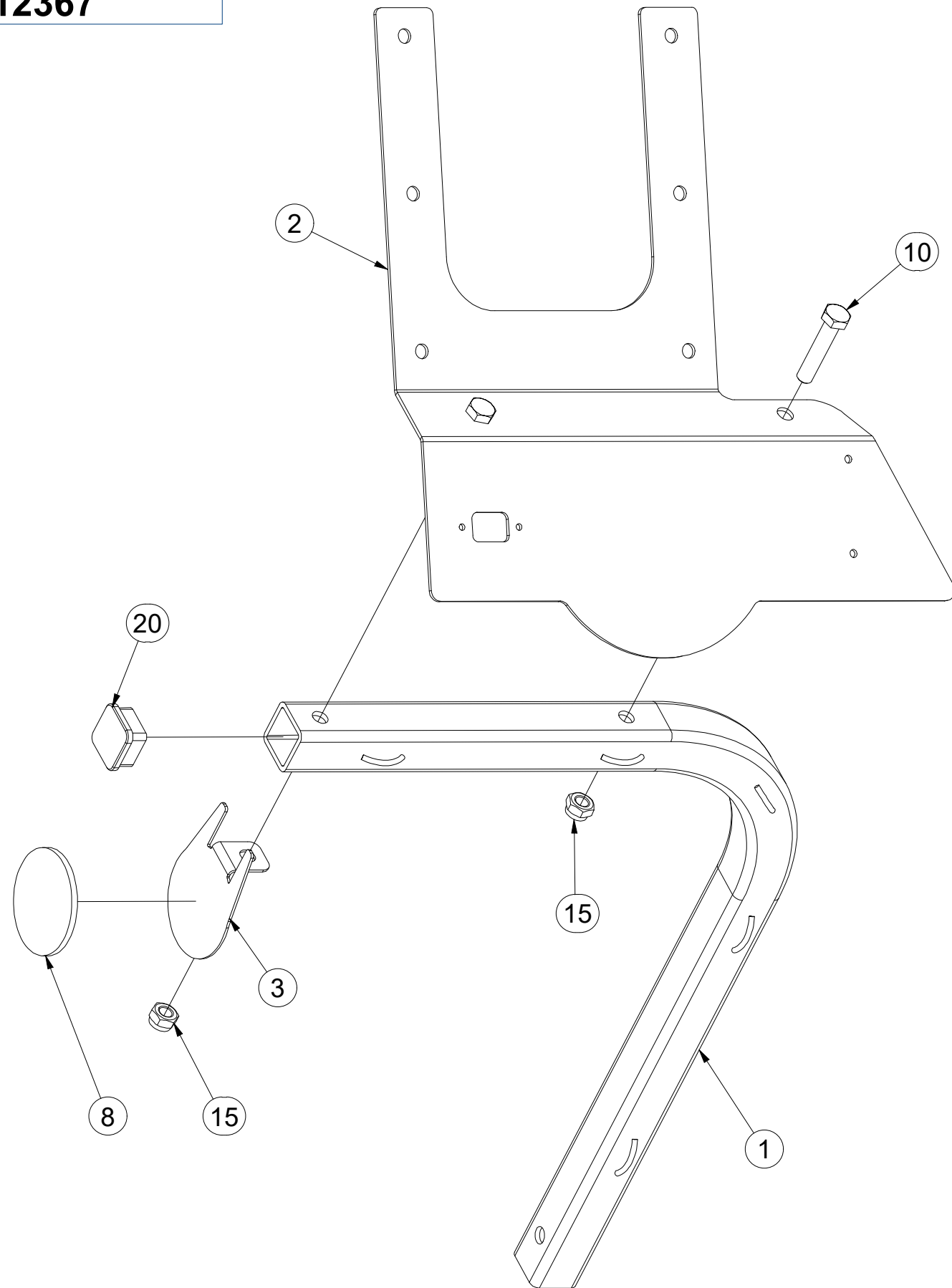

| Pos. | Part Number | Pcs. |
|------|-------------|------|
| 1    | 3012364     | 1    |
| 2    | 3012365     | 1    |
| 3    | 4024926     | 1    |
| 8    | m02579      | 1    |
| 10   | m01131      | 2    |
| 15   | m04301      | 2    |
| 20   | m12689      | 1    |

ⒸZ TERČ ZADNÍ LEVÝ

Ⓓ SCHILD, HINTERES, LINKES

Ⓕ CIBLE ARRIÈRE GAUCHE

ⒼB LEFT REAR DISC

ⒺЩИТОК ЗАДНИЙ ЛЕВЫЙ

ⒶL TARCZA TYLNA LEWA

**Farmet**

**3012367**

| Pos. | Part Number | Pcs. |
|------|-------------|------|
| 5    | m18855      | 1    |
| 6    | 9005707     | 1    |
| 7    | m02497      | 1    |
| 11   | m16637      | 4    |
| 16   | m03775      | 4    |
| 25   | m01209      | 4    |

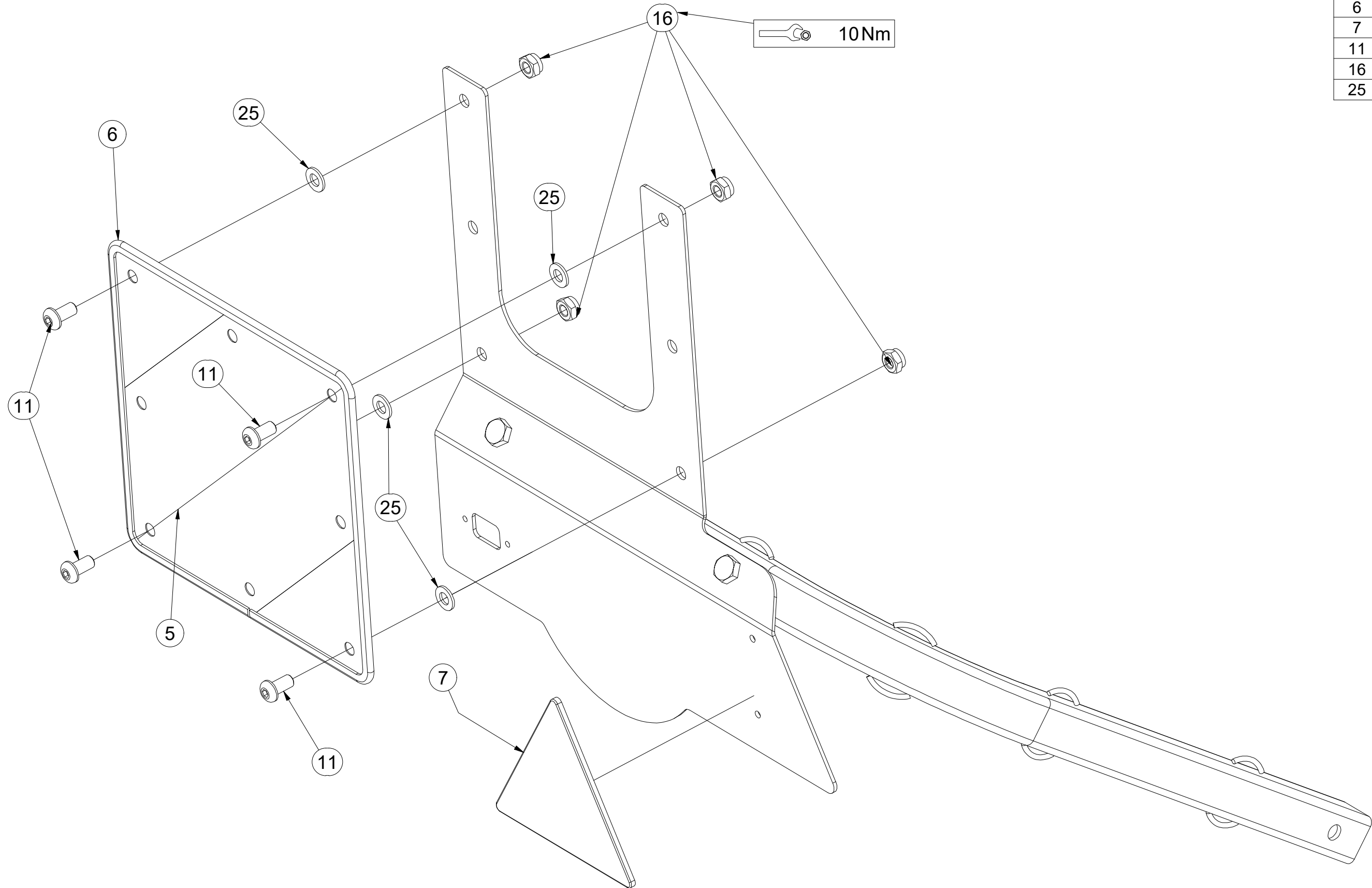

ⒸZ TERČ ZADNÍ PRAVÝ

Ⓓ SCHILD, HINTERES, RECHTES

Ⓕ CIBLE ARRIÈRE DROITE

**3012389**

ⒼB RIGHT REAR DISC

ⒺЩИТОК ЗАДНИЙ ПРАВЫЙ

ⒽL TARCZA TYLNA PRAWA

**Farmet**

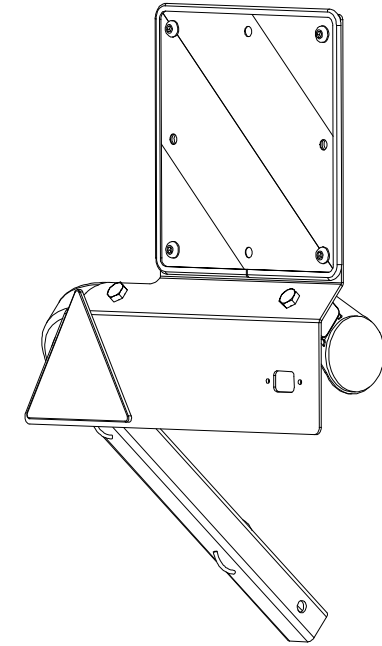
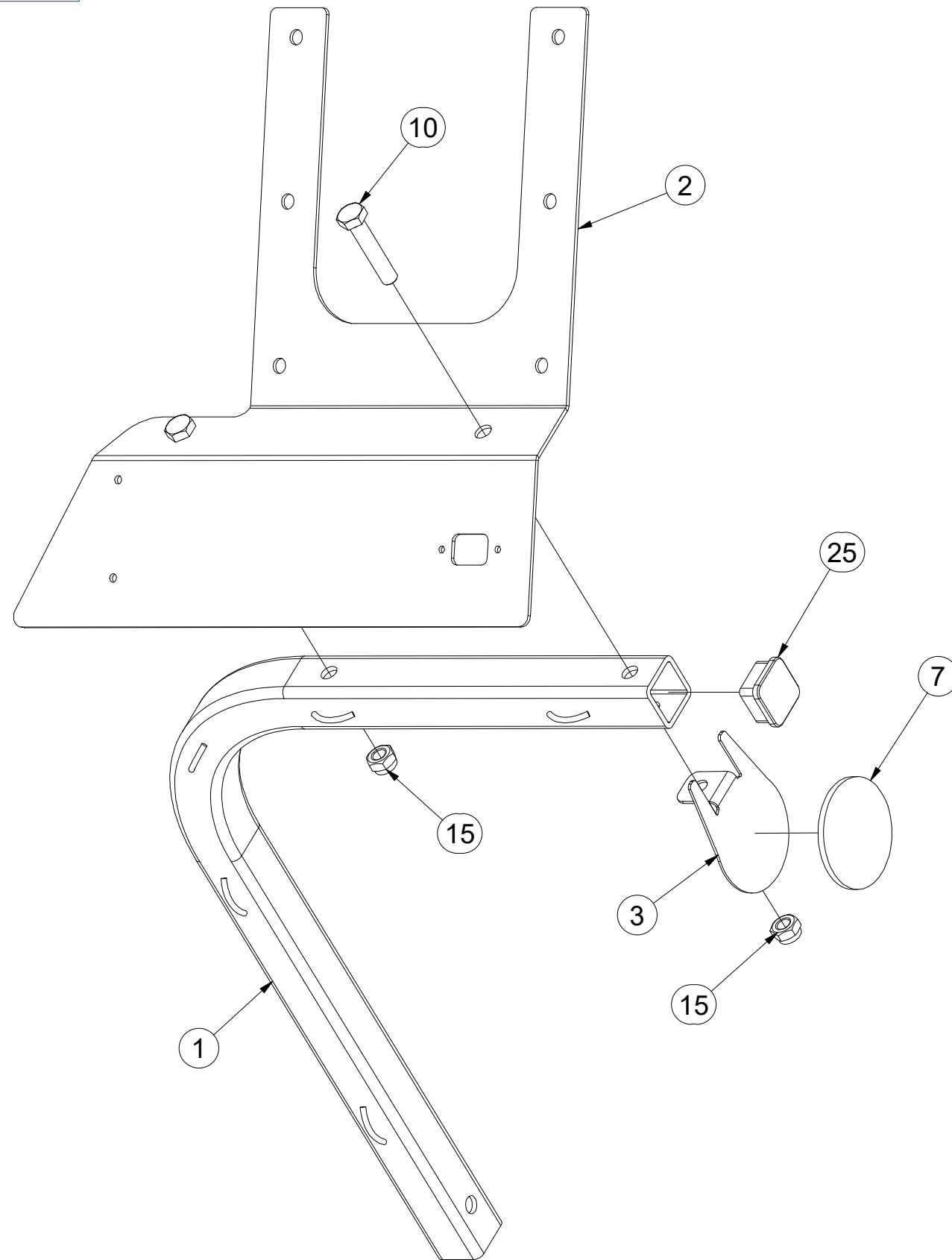

| Pos. | Part Number | Pcs. |
|------|-------------|------|
| 1    | 3012364     | 1    |
| 2    | 3012390     | 1    |
| 3    | 4024926     | 1    |
| 7    | m02579      | 1    |
| 10   | m01131      | 2    |
| 15   | m04301      | 2    |
| 25   | m12689      | 1    |

ⒸZ TERČ ZADNÍ PRAVÝ

Ⓓ SCHILD, HINTERES, RECHTES

Ⓕ CIBLE ARRIÈRE DROITE

ⒼB RIGHT REAR DISC

ⒶU ЩИТОК ЗАДНИЙ ПРАВЫЙ

ⒶL TARCZA TYLNA PRAWA

**Farmet**

**3012389**

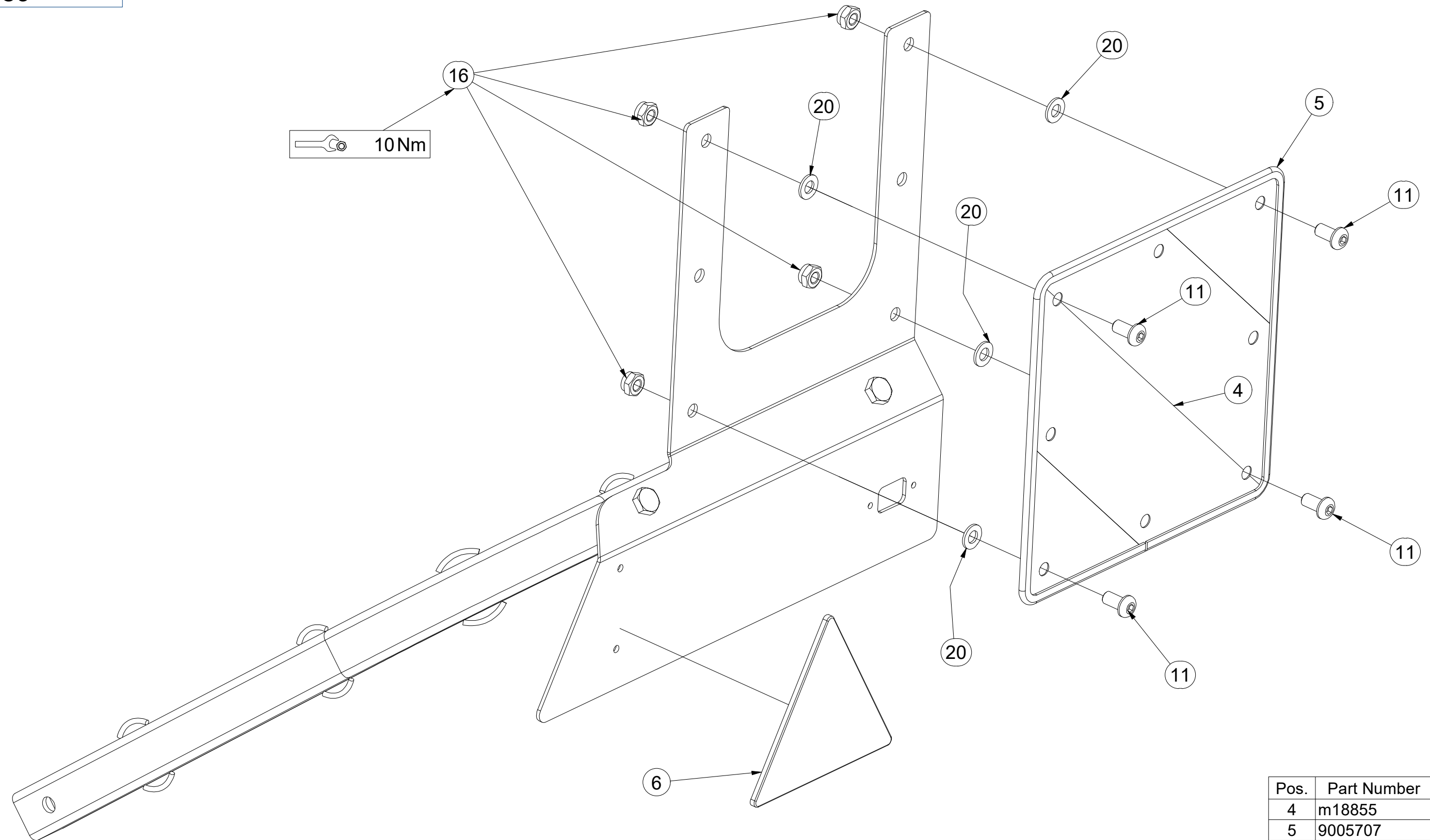

| Pos. | Part Number | Pcs. |
|------|-------------|------|
| 4    | m18855      | 1    |
| 5    | 9005707     | 1    |
| 6    | m02497      | 1    |
| 11   | m16637      | 4    |
| 16   | m03775      | 4    |
| 20   | m01209      | 4    |

Ⓒ VÝSTRAŽNÝ TROJÚHELNÍK

Ⓓ WARNDREIECK

Ⓕ TRIANGLE D'AVERTISSEMENT

Ⓖ EMERGENCY TRIANGLE

Ⓡ ЗНАК АВАРИЙНОЙ ОСТАНОВКИ

Ⓟ TRÓJKAT OSTRZEGAWCZY



**4007398**

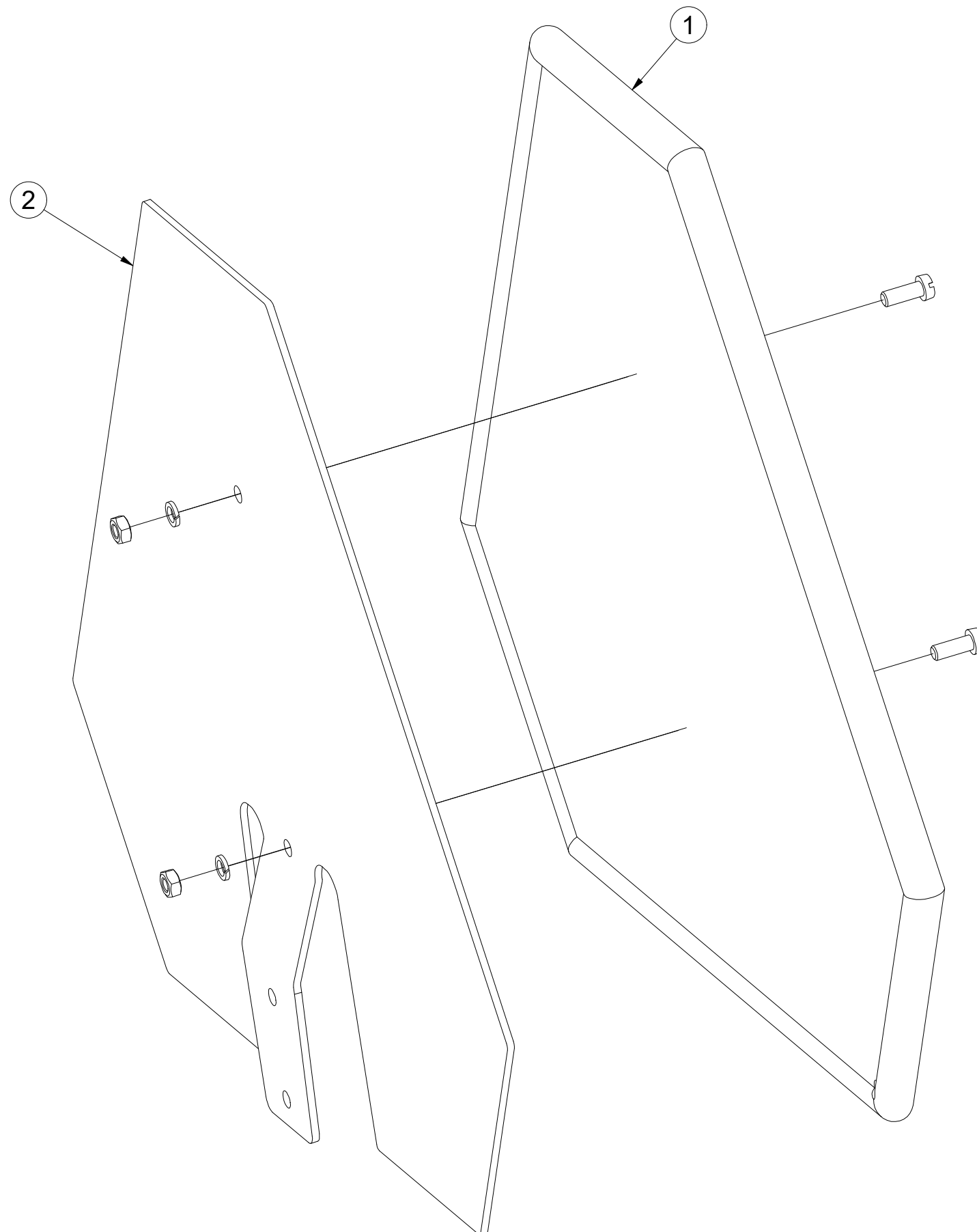
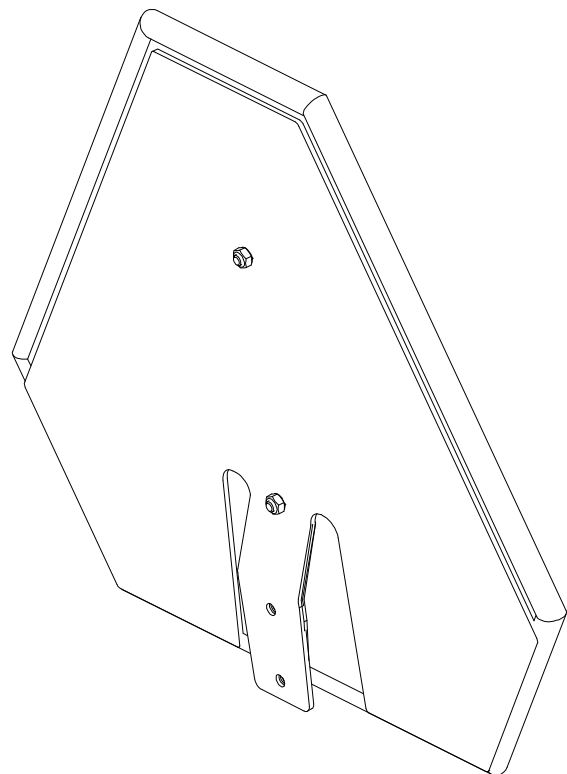

| Pos. | Part Number | Pcs. |
|------|-------------|------|
| 1    | m05371      | 1    |
| 2    | 3003785     | 1    |



ⒸZ HYDRAULICKÝ ROZVOD NÁPRAVY

Ⓓ HYDRAULISCHE VERTEILUNG ACHSE

Ⓕ CONDUIT HYDRAULIQUE DE L'ESSIEU

ⒸB HYDRAULIC AXLE DISTRIBUTION

ⒸR ГИДРАВЛИЧЕСКОЕ РАСПРЕДЕЛЕНИЕ ОСИ

ⒸL HYDRAULICZNY PRZEWÓD OSI

**Farmet**

**VZ00017588**

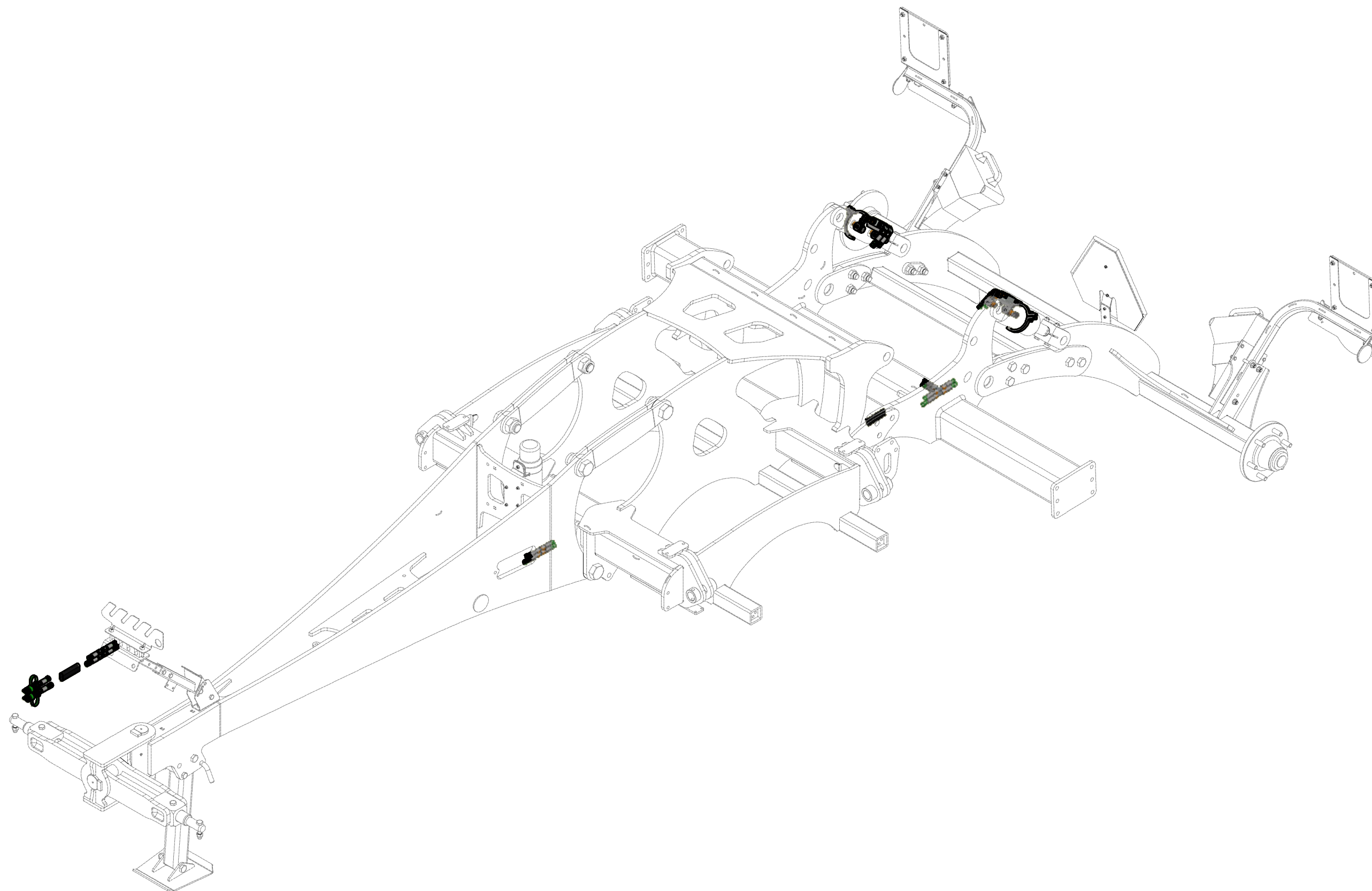

Ⓒ HYDRAULICKÝ ROZVOD NÁPRAVY

Ⓓ HYDRAULISCHE VERTEILUNG ACHSE

Ⓕ CONDUIT HYDRAULIQUE DE L'ESSIEU

Ⓖ HYDRAULIC AXLE DISTRIBUTION

Ⓔ ГИДРАВЛИЧЕСКОЕ РАСПРЕДЕЛЕНИЕ ОСИ

Ⓟ HYDRAULICZNY PRZEWÓD OSI



**VZ00017588**

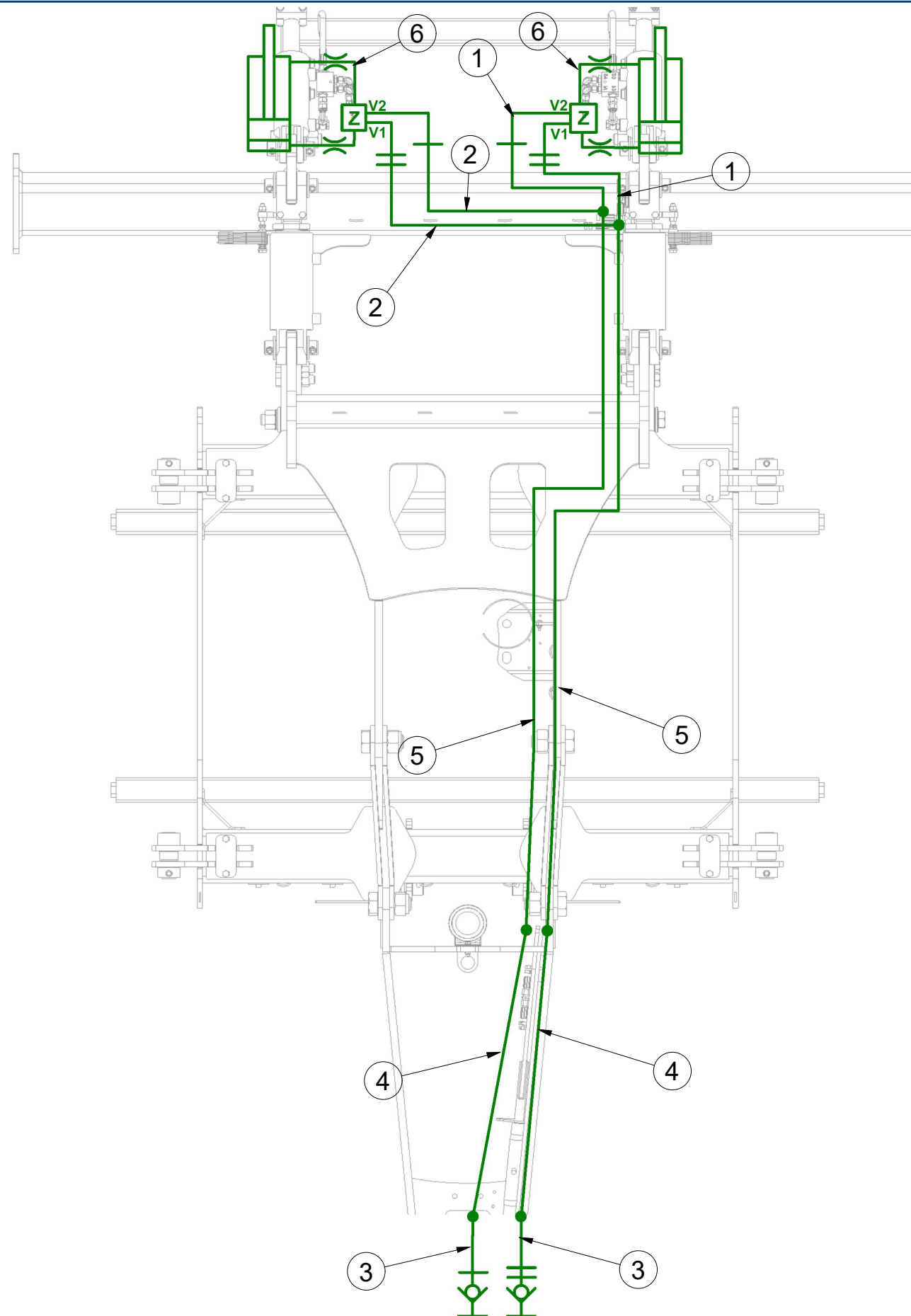

| Pos. | Part Number | Pcs. |
|------|-------------|------|
| 1    | m04827      | 2    |
| 2    | m07360      | 2    |
| 3    | m11696      | 2    |
| 4    | m07650      | 2    |
| 5    | m12022      | 2    |
| 6    | m03845      | 2    |

ⒸZ HYDRAULICKÝ ROZVOD NÁPRAVY

Ⓓ HYDRAULISCHE VERTEILUNG ACHSE

Ⓕ CONDUIT HYDRAULIQUE DE L'ESSIEU

ⒸB HYDRAULIC AXLE DISTRIBUTION

ⒸU ГИДРАВЛИЧЕСКОЕ РАСПРЕДЕЛЕНИЕ ОСИ

ⒸL HYDRAULICZNY PRZEWÓD OSI



**VZ00017588**

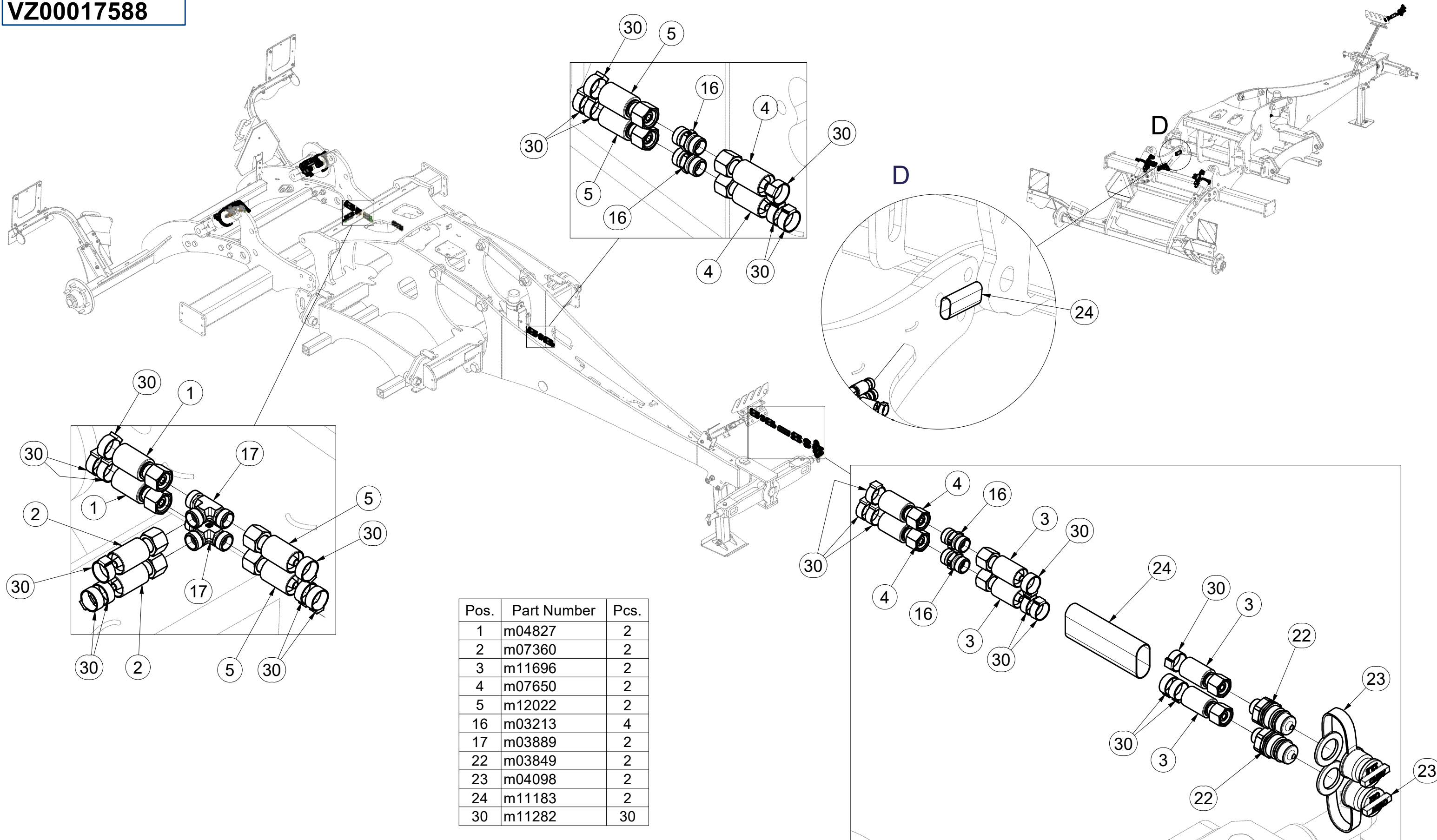

ⒸZ HYDRAULICKÝ ROZVOD NÁPRAVY

Ⓓ HYDRAULISCHE VERTEILUNG ACHSE

Ⓕ CONDUIT HYDRAULIQUE DE L'ESSIEU

**VZ00017588**

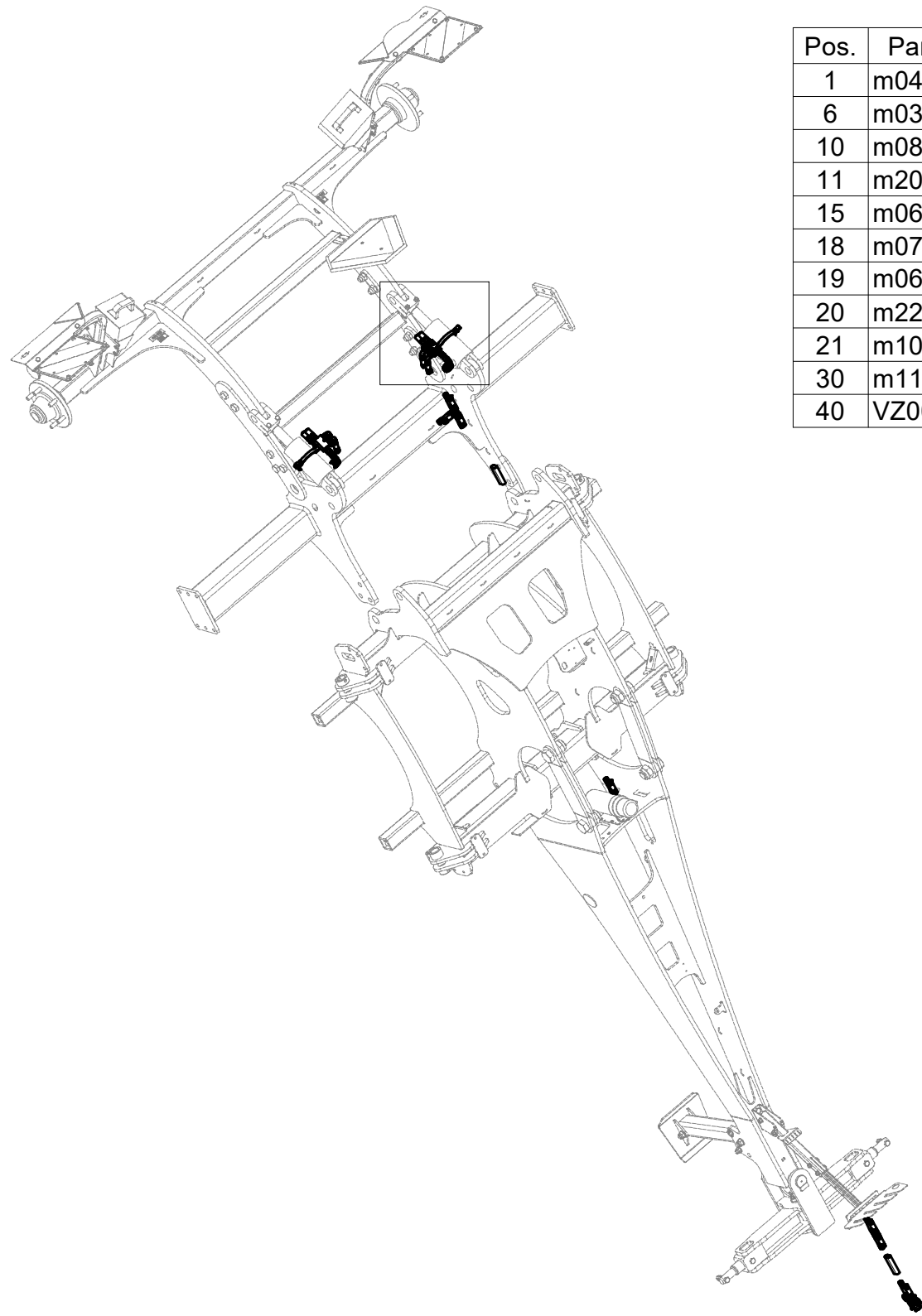

| Pos. | Part Number | Pcs. |
|------|-------------|------|
| 1    | m04827      | 2    |
| 6    | m03845      | 2    |
| 10   | m08083      | 2    |
| 11   | m20912      | 4    |
| 15   | m06528      | 4    |
| 18   | m07654      | 2    |
| 19   | m06803      | 4    |
| 20   | m22306      | 2    |
| 21   | m10776      | 4    |
| 30   | m11282      | 30   |
| 40   | VZ00010409  | 2    |

ⒸGB HYDRAULIC AXLE DISTRIBUTION

ⒸRU ГИДРАВЛИЧЕСКОЕ РАСПРЕДЕЛЕНИЕ ОСИ

ⒸPL HYDRAULICZNY PRZEWÓD OSI

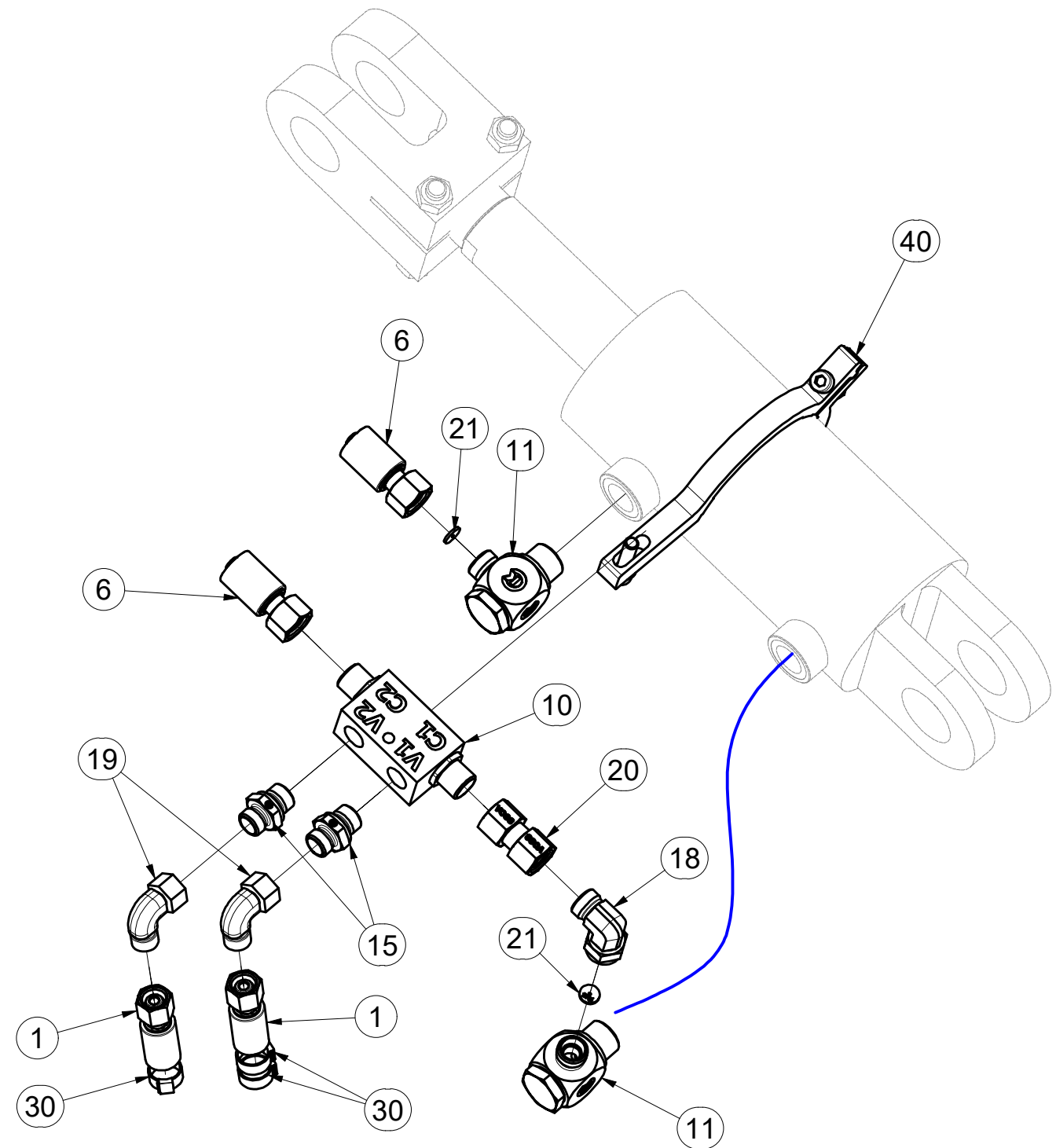

ⒸZ HYDRAULICKÝ ROZVOD NÁPRAVY

Ⓓ HYDRAULISCHE VERTEILUNG ACHSE

Ⓕ CONDUIT HYDRAULIQUE DE L'ESSIEU

ⒸB HYDRAULIC AXLE DISTRIBUTION

ⒸU ГИДРАВЛИЧЕСКОЕ РАСПРЕДЕЛЕНИЕ ОСИ

ⒸL HYDRAULICZNY PRZEWÓD OSI



**VZ00017588**

| Pos. | Part Number | Pcs. |
|------|-------------|------|
| 2    | m07360      | 2    |
| 6    | m03845      | 2    |
| 10   | m08083      | 2    |
| 11   | m20912      | 4    |
| 15   | m06528      | 4    |
| 18   | m07654      | 2    |
| 19   | m06803      | 4    |
| 20   | m22306      | 2    |
| 21   | m10776      | 4    |
| 30   | m11282      | 30   |
| 40   | VZ00010409  | 2    |

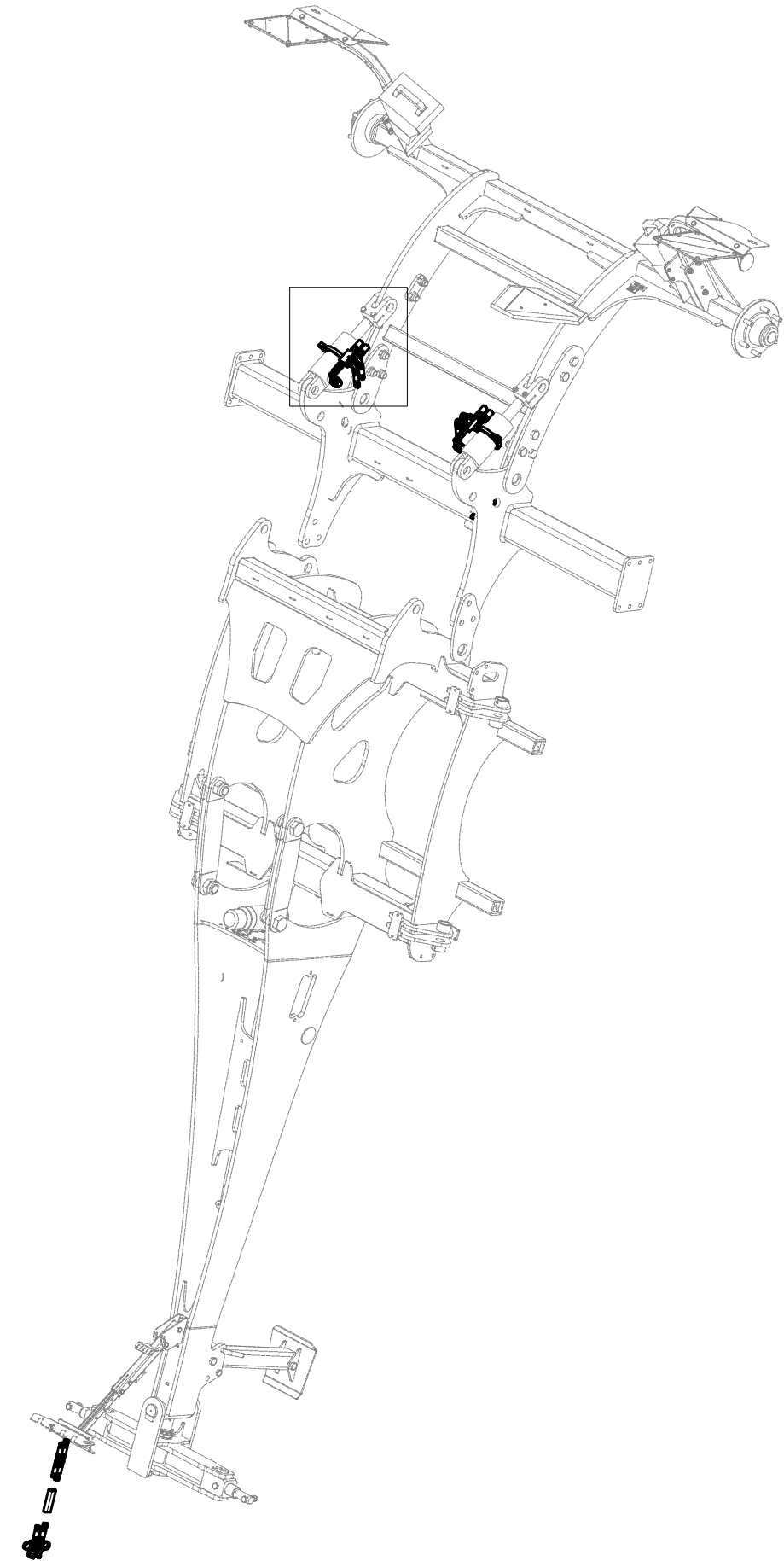
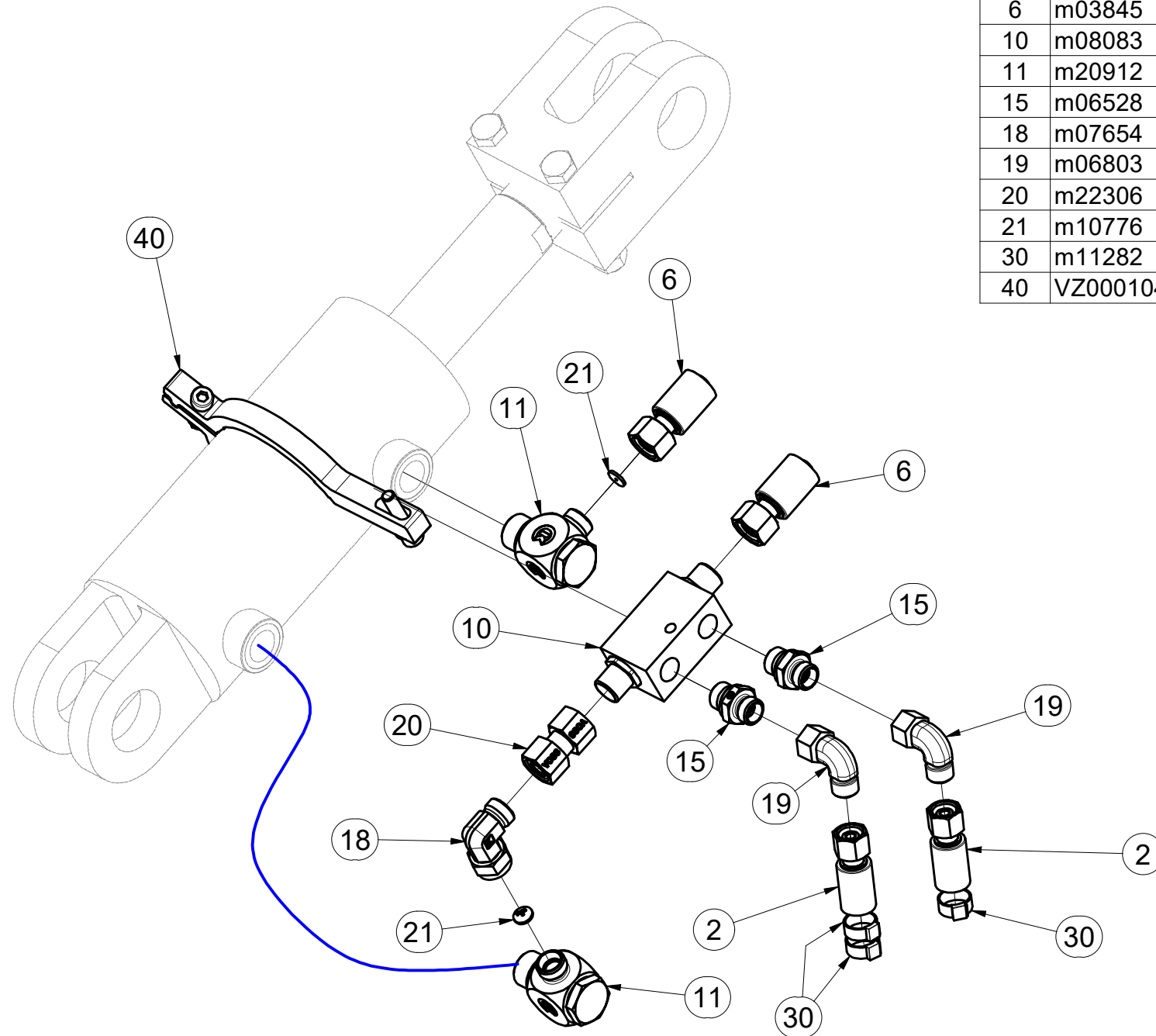

ⒸZ HYDRAULICKÝ ROZVOD SKLÁPĚNÍ

Ⓓ HYDRAULISCHE VERTEILUNG KLAPPMECHANISMUS

Ⓕ CONDUIT HYDRAULIQUE DU BASCULEMENT

ⒸB HYDRAULIC FOLDING DISTRIBUTION

ⒸR ГИДРАВЛИЧЕСКОЕ РАСПРЕДЕЛЕНИЕ СКЛАДЫВАНИЯ

ⒸL HYDRAULICZNY PRZEWÓD SKŁADANIA

**Farmet**

**VZ00017640**

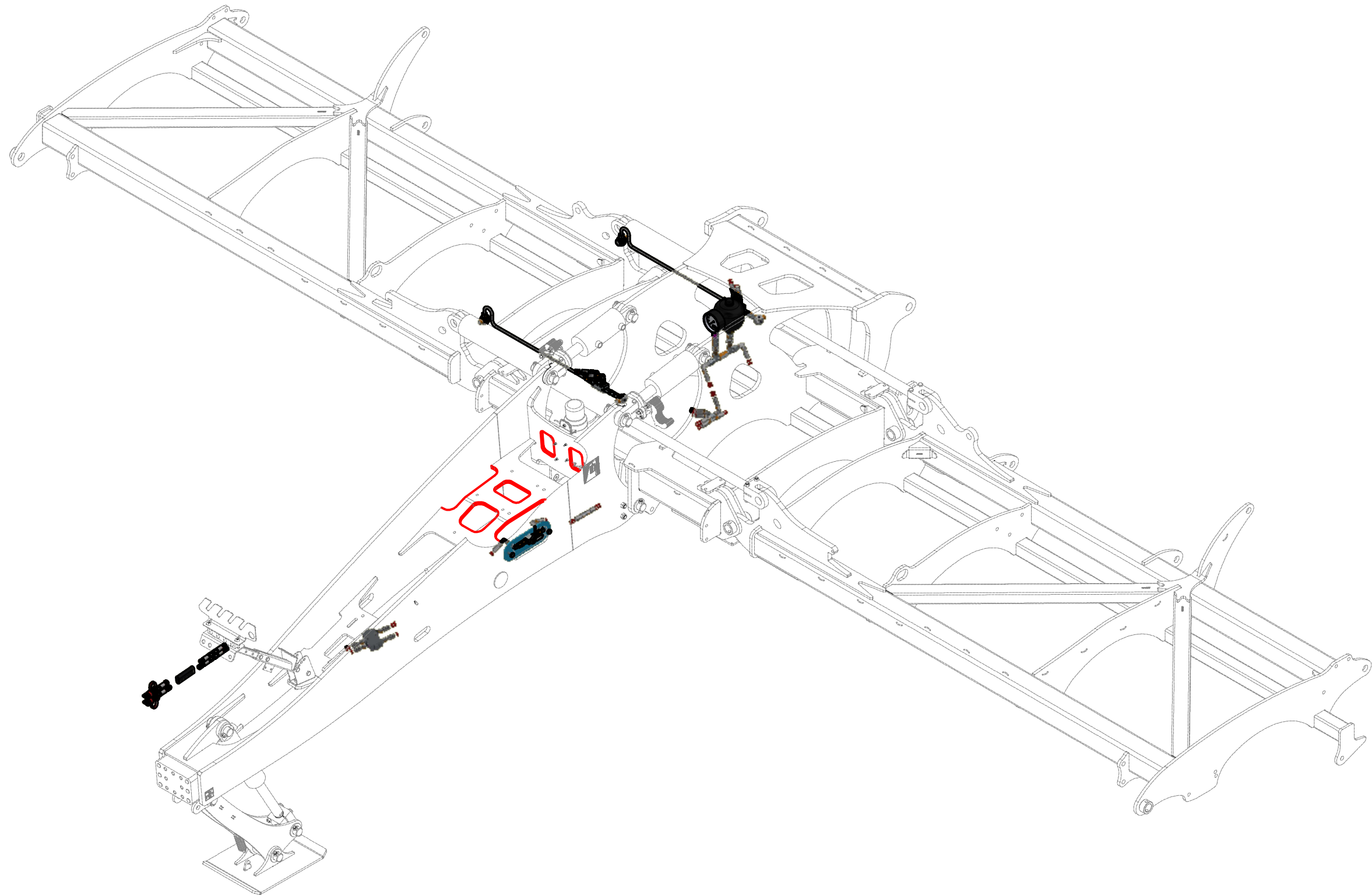

ⒸZ HYDRAULICKÝ ROZVOD SKLÁPĚNÍ

Ⓓ HYDRAULISCHE VERTEILUNG KLAPPMECHANISMUS

Ⓕ CONDUIT HYDRAULIQUE DU BASCULEMENT

ⒸB HYDRAULIC FOLDING DISTRIBUTION

ⒸU ГИДРАВЛИЧЕСКОЕ РАСПРЕДЕЛЕНИЕ СКЛАДЫВАНИЯ

ⒸL HYDRAULICZNY PRZEWÓD SKŁADANIA



**VZ00017640**

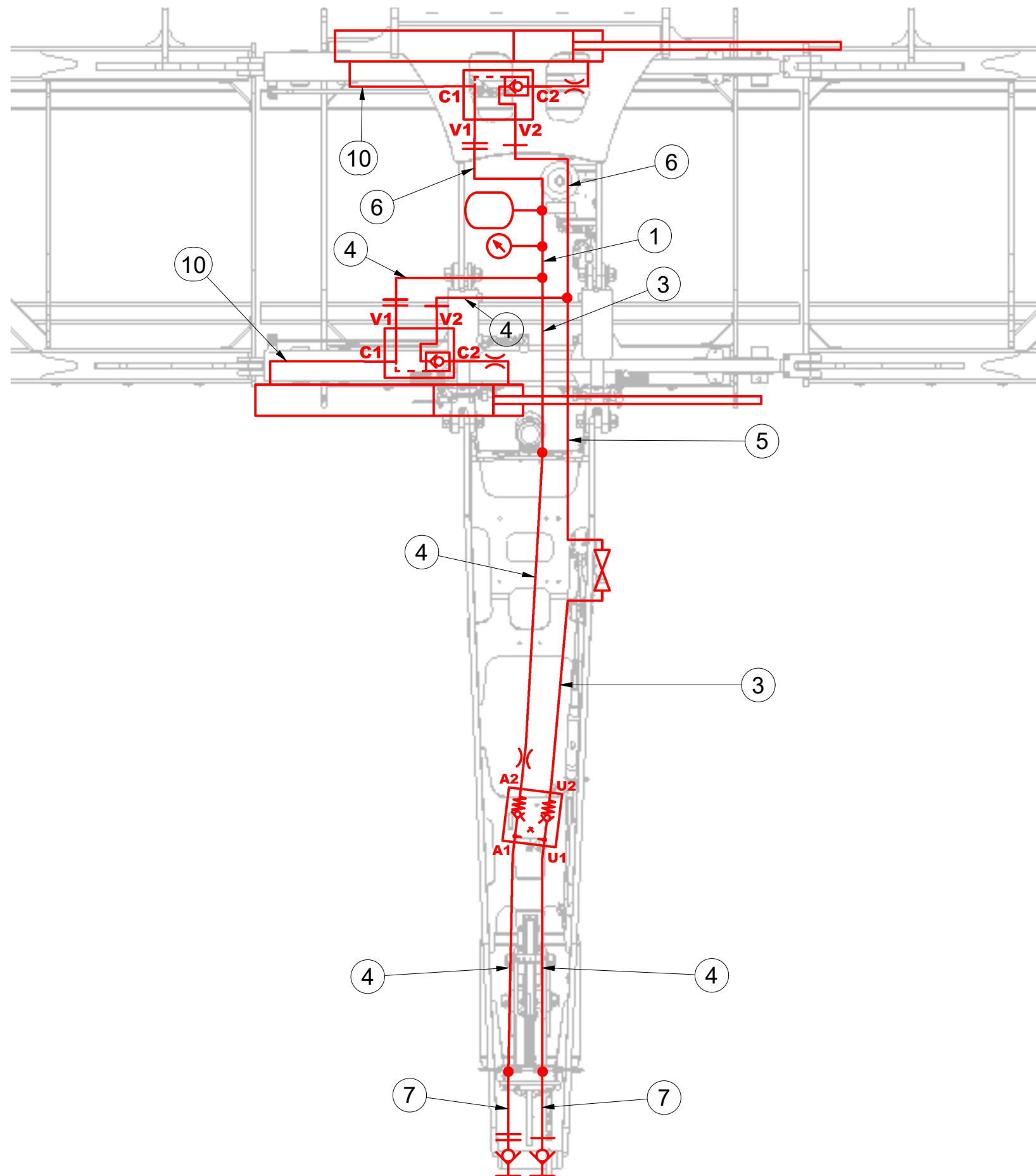

| Pos. | Part Number | Pcs. |
|------|-------------|------|
| 1    | m18625      | 1    |
| 3    | m04033      | 2    |
| 4    | m07647      | 5    |
| 5    | m17043      | 1    |
| 6    | m03952      | 2    |
| 7    | m11696      | 2    |
| 10   | m16714      | 2    |

ⒸZ HYDRAULICKÝ ROZVOD SKLÁPĚNÍ

Ⓓ HYDRAULISCHE VERTEILUNG KLAPPMECHANISMUS

Ⓕ CONDUIT HYDRAULIQUE DU BASCULEMENT

ⒸB HYDRAULIC FOLDING DISTRIBUTION

ⒸU ГИДРАВЛИЧЕСКОЕ РАСПРЕДЕЛЕНИЕ СКЛАДЫВАНИЯ

ⒸL HYDRAULICZNY PRZEWÓD SKŁADANIA



**VZ00017640**

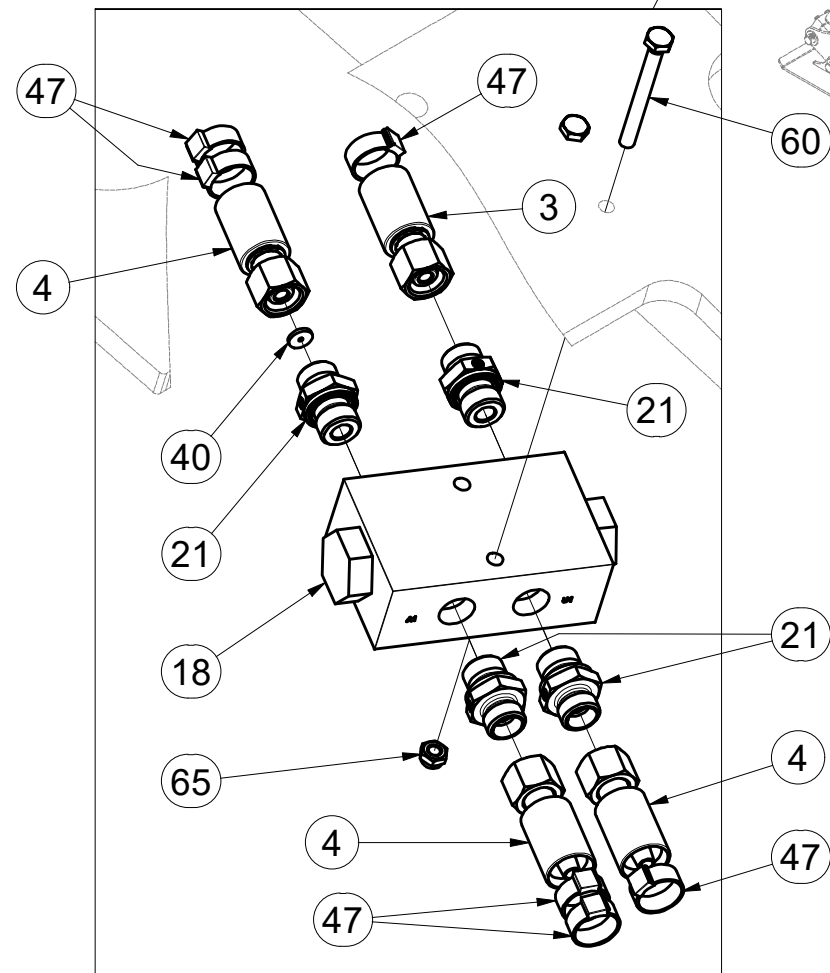
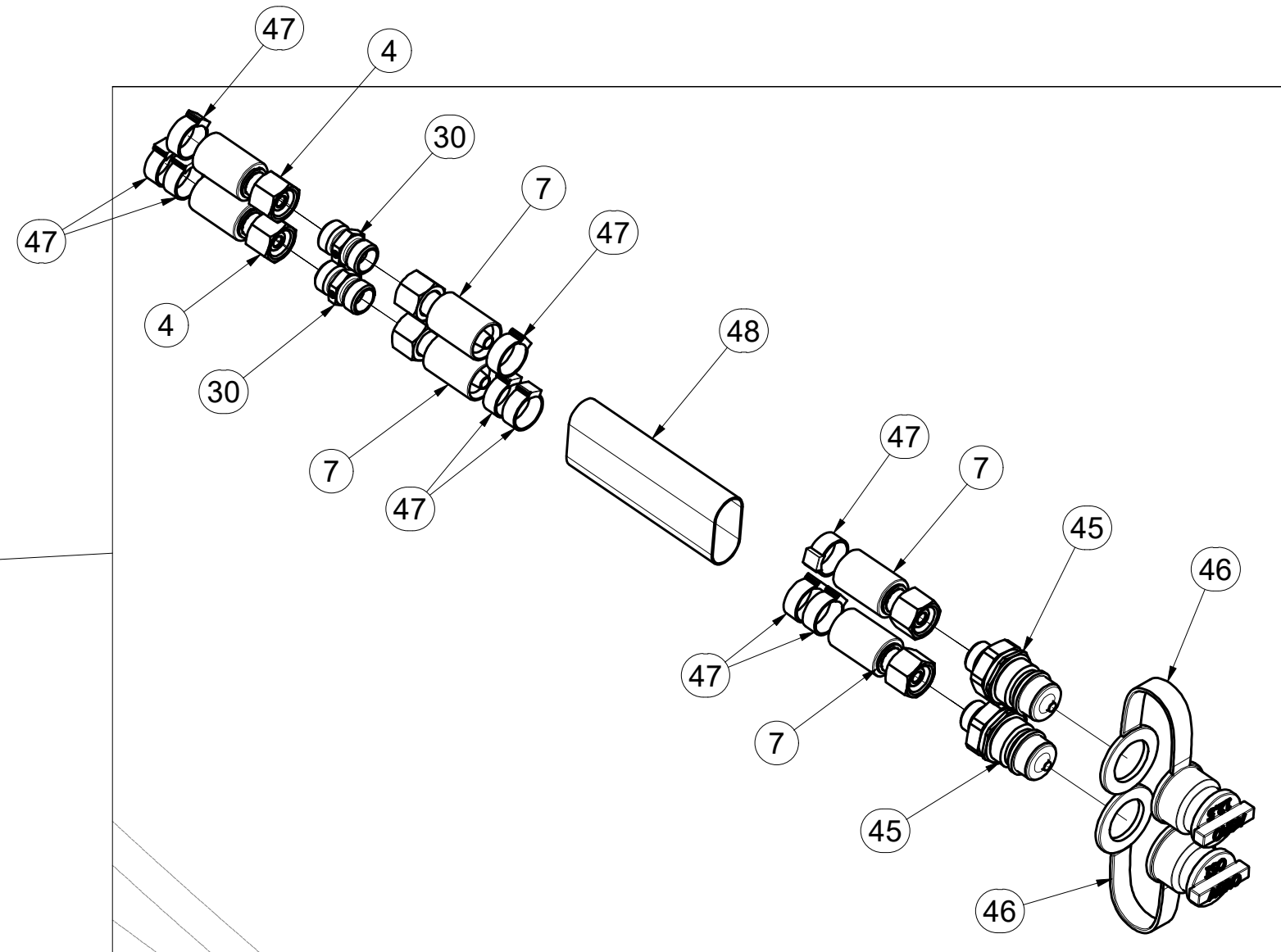
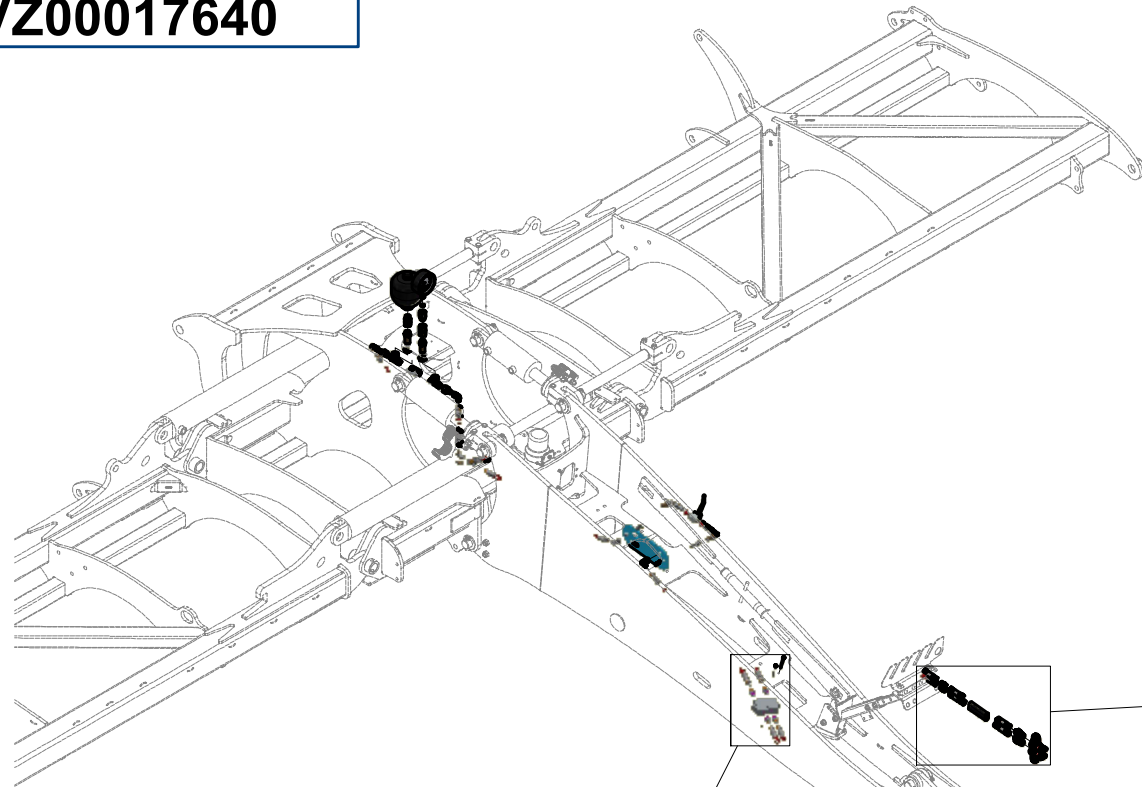

| Pos. | Part Number | Pcs. |
|------|-------------|------|
| 4    | m07647      | 5    |
| 7    | m11696      | 2    |
| 18   | m09911      | 1    |
| 21   | m06528      | 8    |
| 30   | m03213      | 3    |
| 40   | m10777      | 1    |
| 45   | m03849      | 2    |
| 46   | m04022      | 2    |
| 47   | m11294      | 42   |
| 48   | m11183      | 1    |
| 60   | m13696      | 2    |
| 65   | m05560      | 2    |



ⒸZ HYDRAULICKÝ ROZVOD SKLÁPĚNÍ

Ⓓ HYDRAULISCHE VERTEILUNG KLAPPMECHANISMUS

Ⓕ CONDUIT HYDRAULIQUE DU BASCULEMENT

ⒸB HYDRAULIC FOLDING DISTRIBUTION

ⒸU ГИДРАВЛИЧЕСКОЕ РАСПРЕДЕЛЕНИЕ СКЛАДЫВАНИЯ

ⒸL HYDRAULICZNY PRZEWÓD SKŁADANIA

**Farmet**

**VZ00017640**

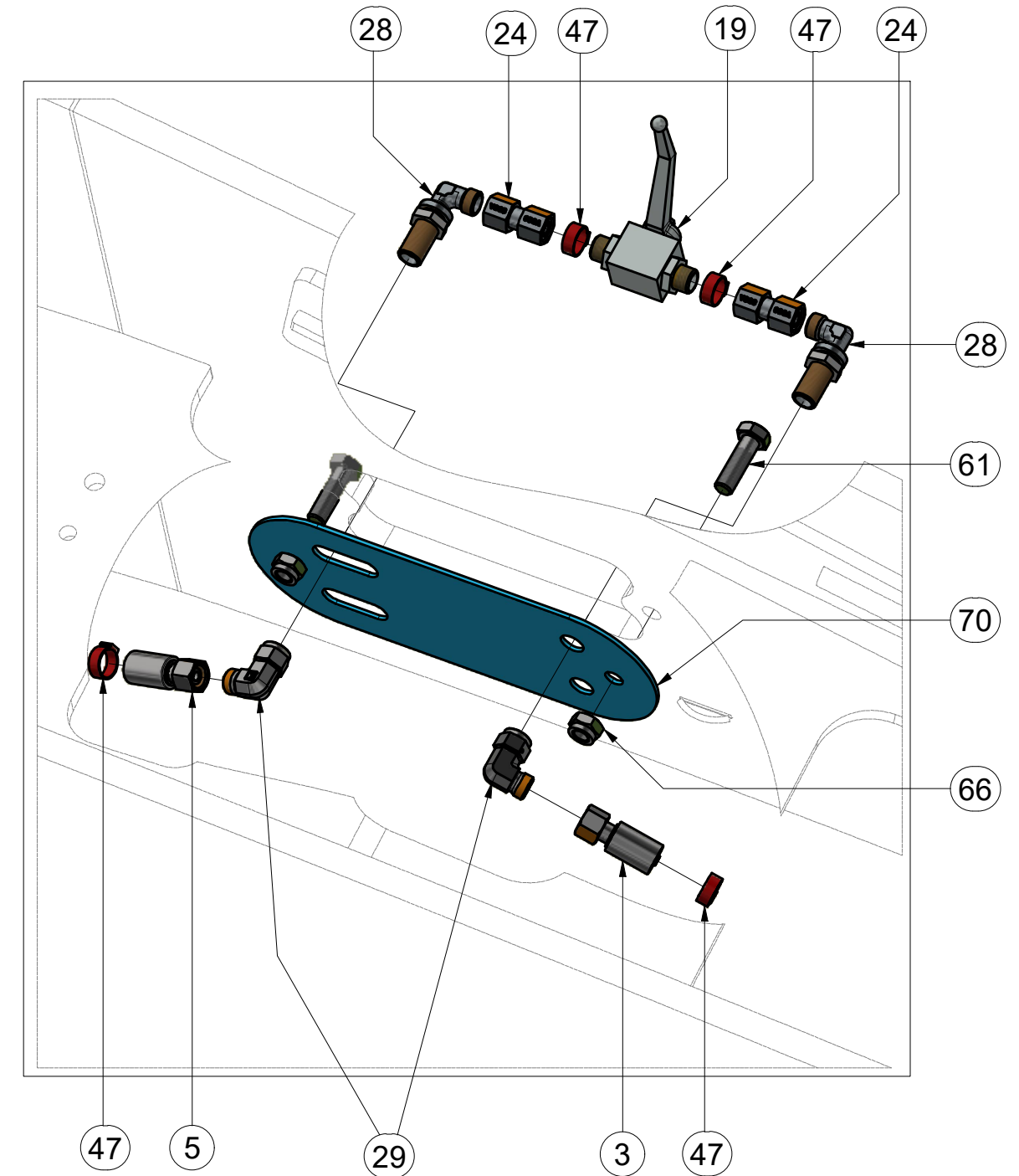
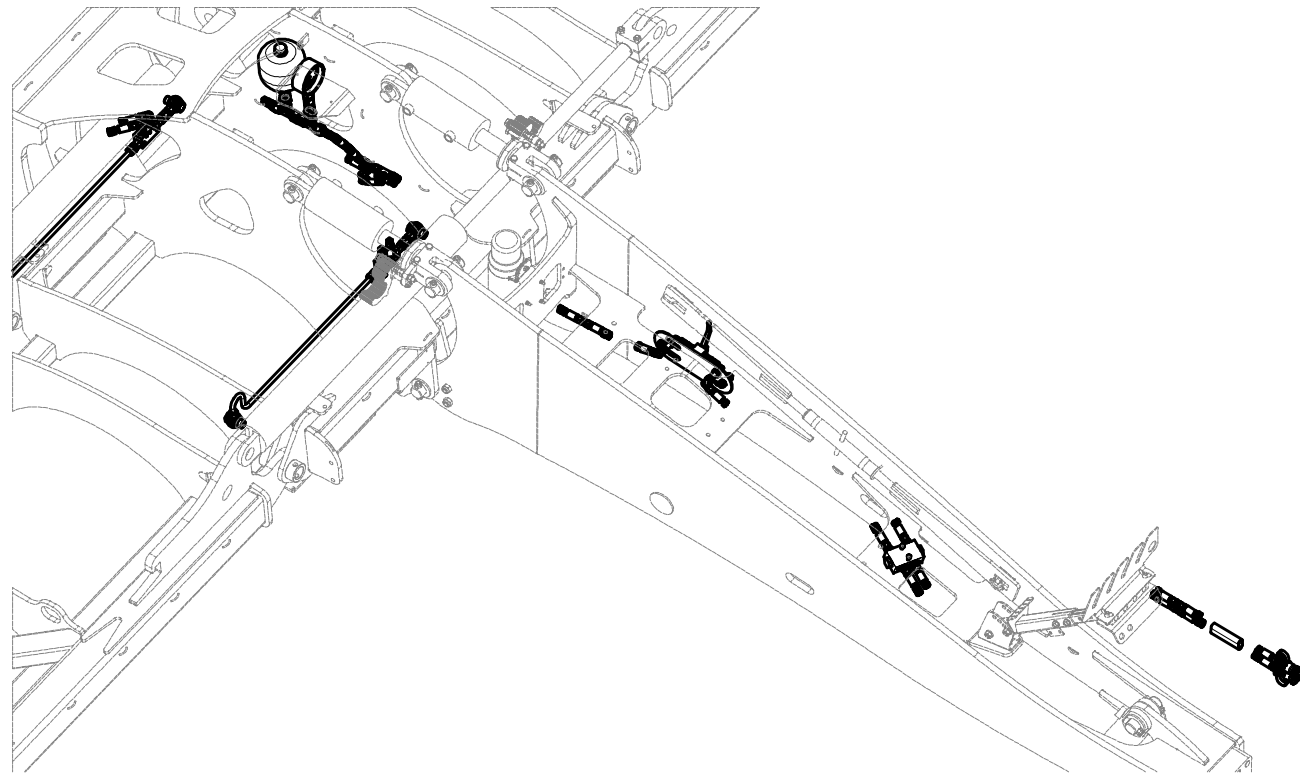

| Pos. | Part Number | Pcs. |
|------|-------------|------|
| 5    | m17043      | 1    |
| 19   | m04623      | 1    |
| 24   | m22305      | 2    |
| 28   | m08391      | 2    |
| 29   | m06803      | 11   |
| 47   | m11294      | 42   |
| 61   | m03926      | 2    |
| 66   | m04301      | 2    |
| 70   | 4025719     | 1    |

ⒸZ HYDRAULICKÝ ROZVOD SKLÁPĚNÍ

Ⓓ HYDRAULISCHE VERTEILUNG KLAPPMECHANISMUS

Ⓕ CONDUIT HYDRAULIQUE DU BASCULEMENT

ⒸB HYDRAULIC FOLDING DISTRIBUTION

ⒸU ГИДРАВЛИЧЕСКОЕ РАСПРЕДЕЛЕНИЕ СКЛАДЫВАНИЯ

ⒸL HYDRAULICZNY PRZEWÓD SKŁADANIA



**VZ00017640**

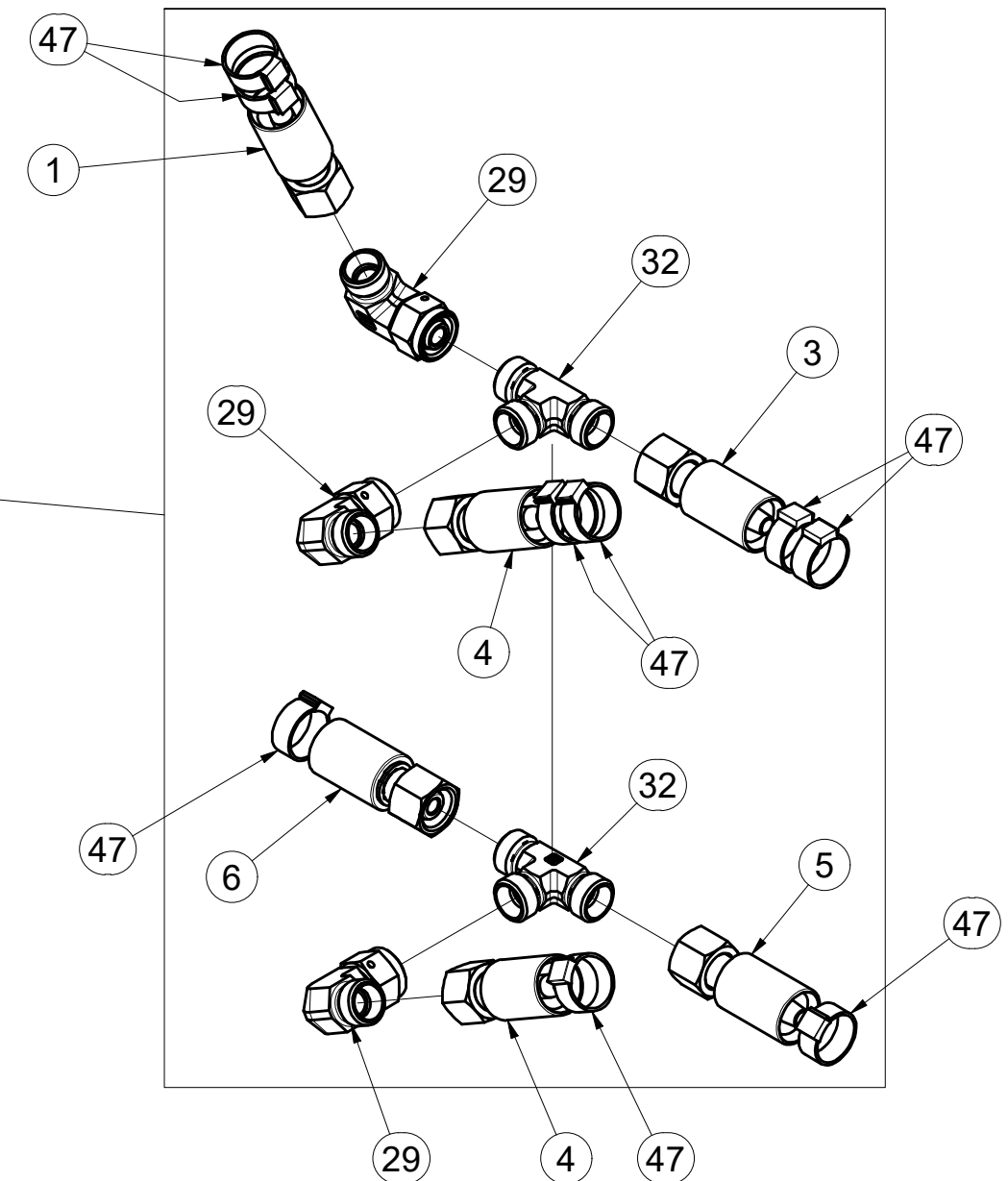
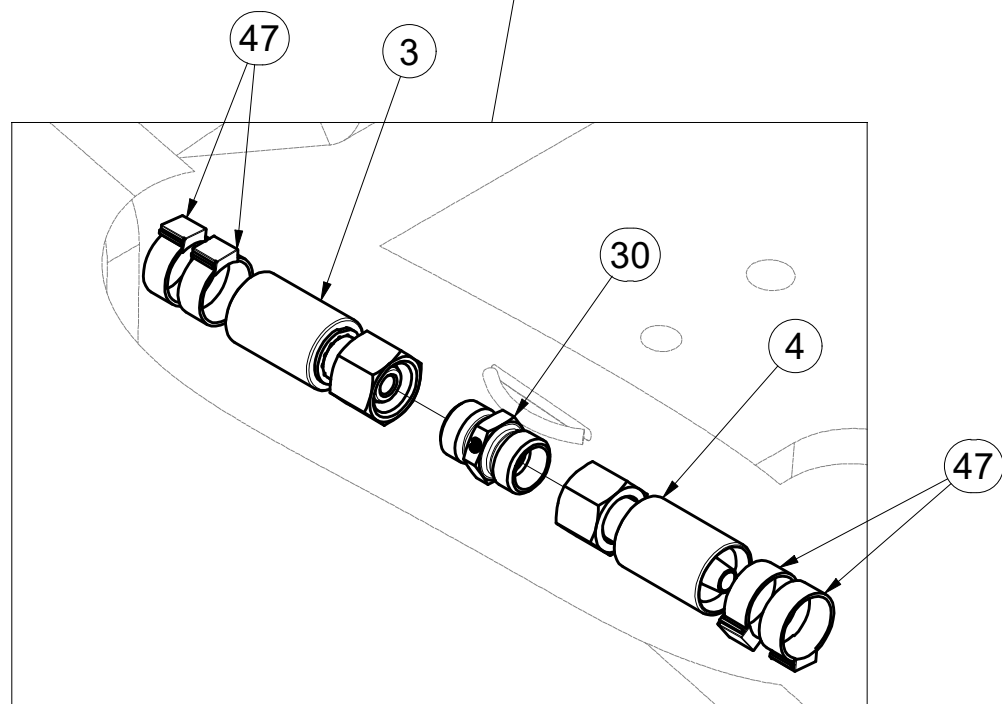
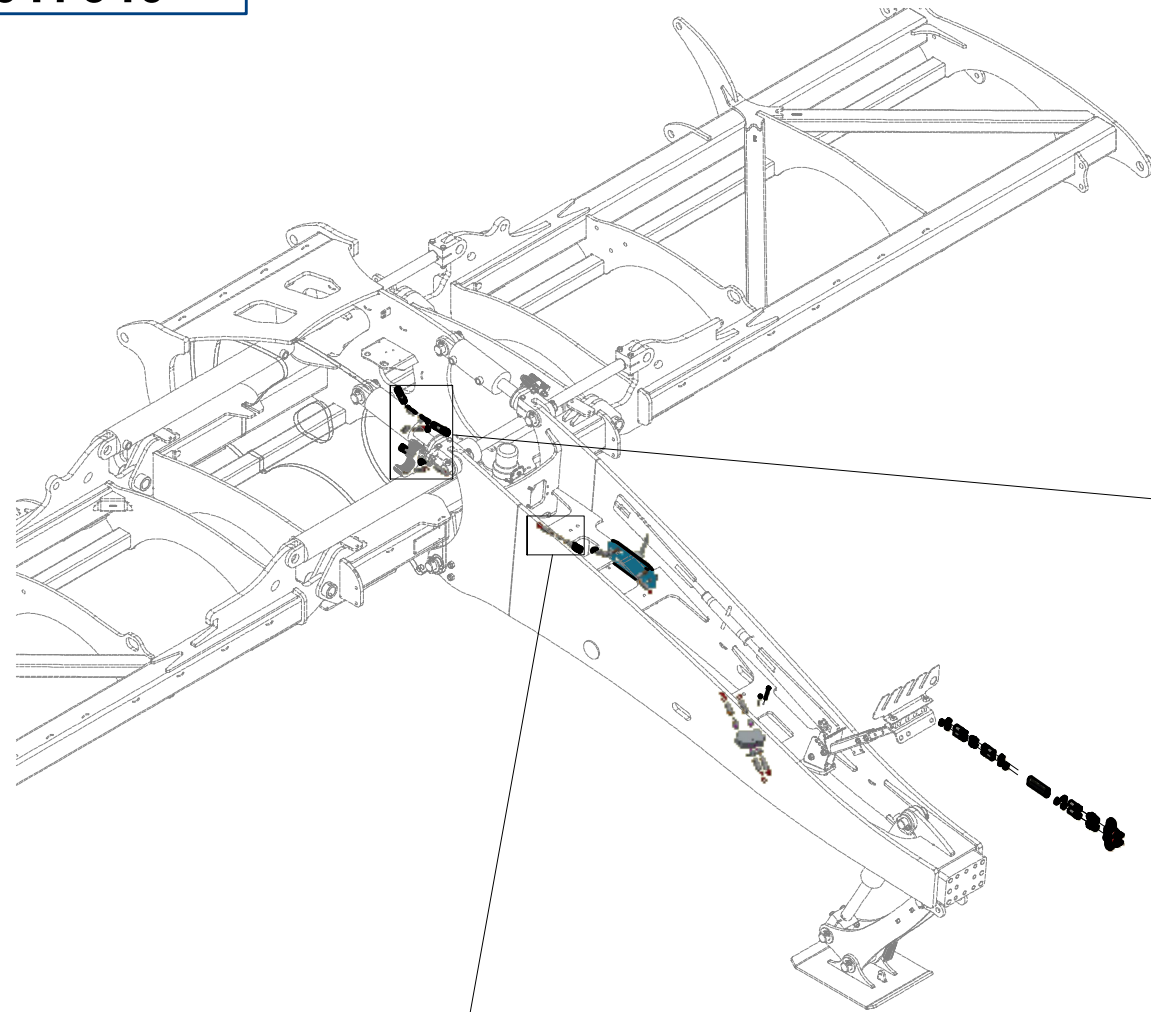

| Pos. | Part Number | Pcs. |
|------|-------------|------|
| 1    | m18625      | 1    |
| 3    | m04033      | 2    |
| 4    | m07647      | 5    |
| 5    | m17043      | 1    |
| 6    | m03952      | 2    |
| 29   | m06803      | 11   |
| 30   | m03213      | 3    |
| 32   | m03889      | 2    |
| 47   | m11294      | 42   |

Ⓒ HYDRAULICKÝ ROZVOD SKLÁPĚNÍ

Ⓓ HYDRAULISCHE VERTEILUNG KLAPPMECHANISMUS

Ⓕ CONDUIT HYDRAULIQUE DU BASCULEMENT

Ⓒ HYDRAULIC FOLDING DISTRIBUTION

Ⓓ ГИДРАВЛИЧЕСКОЕ РАСПРЕДЕЛЕНИЕ СКЛАДЫВАНИЯ

Ⓕ HYDRAULICZNY PRZEWÓD SKŁADANIA



**VZ00017640**

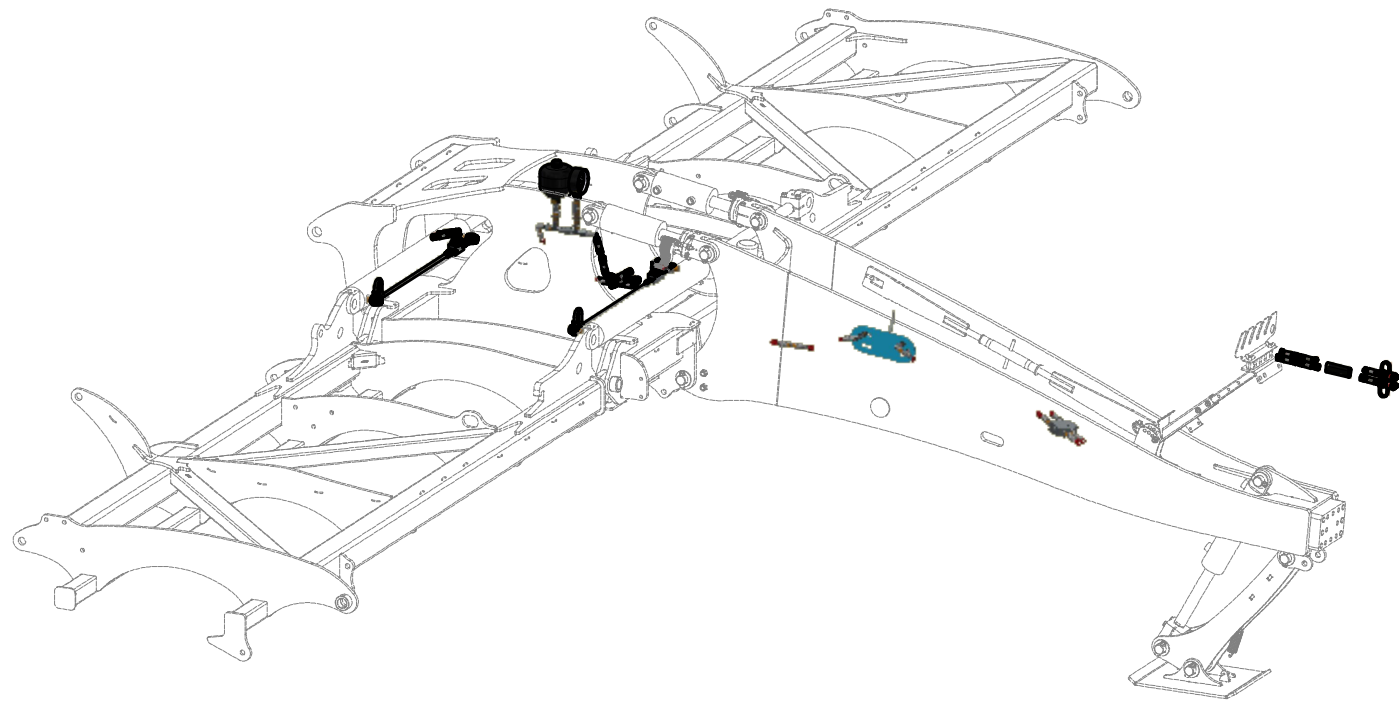

| Pos. | Part Number | Pcs. |
|------|-------------|------|
| 1    | m18625      | 1    |
| 6    | m03952      | 2    |
| 13   | m11974      | 1    |
| 15   | m09910      | 1    |
| 16   | m05518      | 1    |
| 22   | m07993      | 1    |
| 25   | m22307      | 2    |
| 27   | m08533      | 2    |
| 29   | m06803      | 11   |
| 31   | m09625      | 2    |
| 33   | m06879      | 2    |
| 38   | m04320      | 1    |
| 47   | m11294      | 42   |

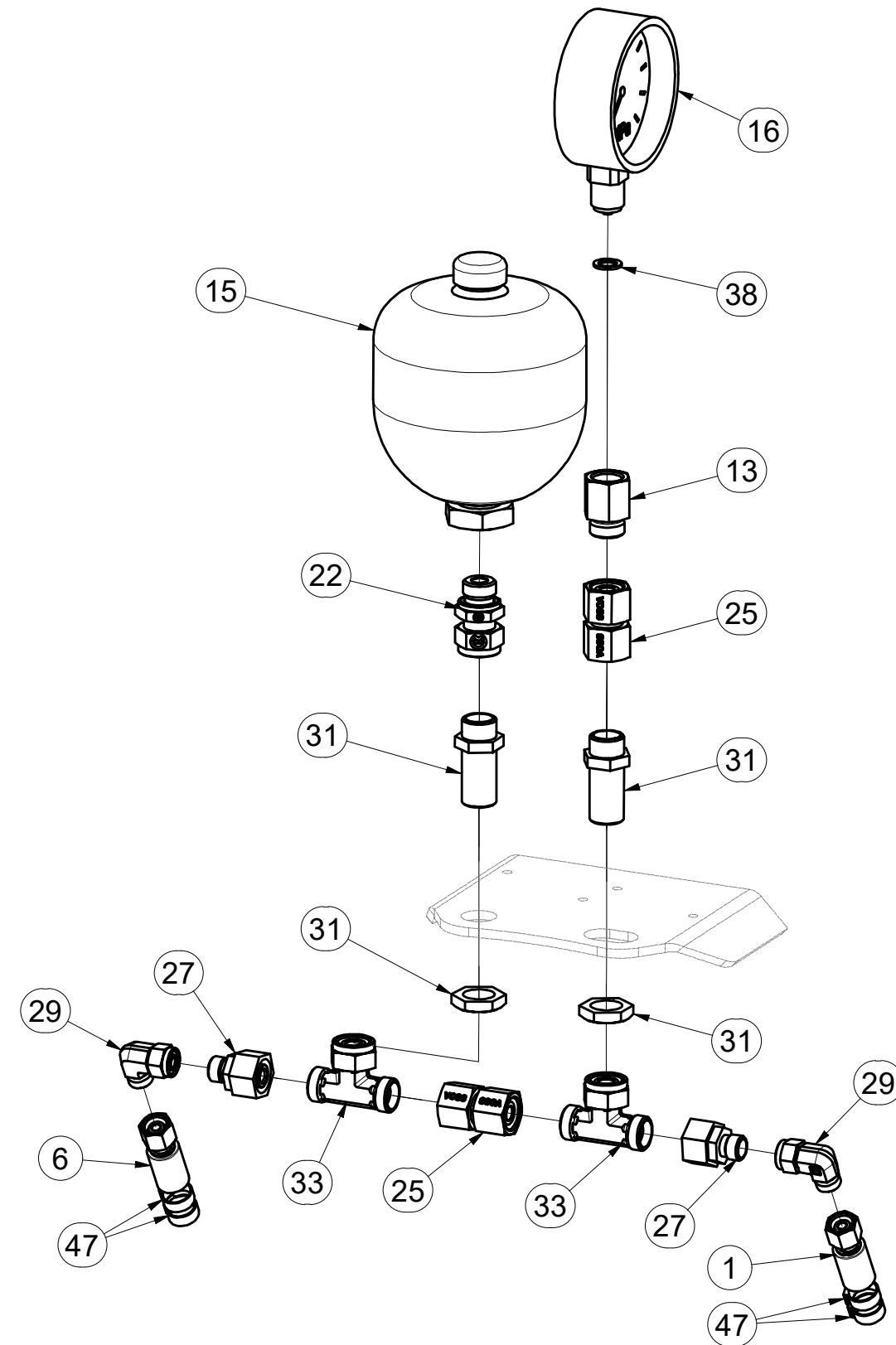

ⒸZ HYDRAULICKÝ ROZVOD SKLÁPĚNÍ

Ⓓ HYDRAULISCHE VERTEILUNG KLAPPMECHANISMUS

Ⓕ CONDUIT HYDRAULIQUE DU BASCULEMENT

ⒸB HYDRAULIC FOLDING DISTRIBUTION

ⒸU ГИДРАВЛИЧЕСКОЕ РАСПРЕДЕЛЕНИЕ СКЛАДЫВАНИЯ

ⒸL HYDRAULICZNY PRZEWÓD SKŁADANIA

**Farmet**

**VZ00017640**

| Pos. | Part Number | Pcs. |
|------|-------------|------|
| 6    | m03952      | 2    |
| 10   | m16714      | 2    |
| 17   | m11103      | 2    |
| 20   | m20912      | 4    |
| 21   | m06528      | 8    |
| 23   | m06320      | 4    |
| 26   | m22306      | 2    |
| 29   | m06803      | 11   |
| 35   | m17321      | 4    |
| 39   | m10774      | 2    |
| 47   | m11294      | 42   |

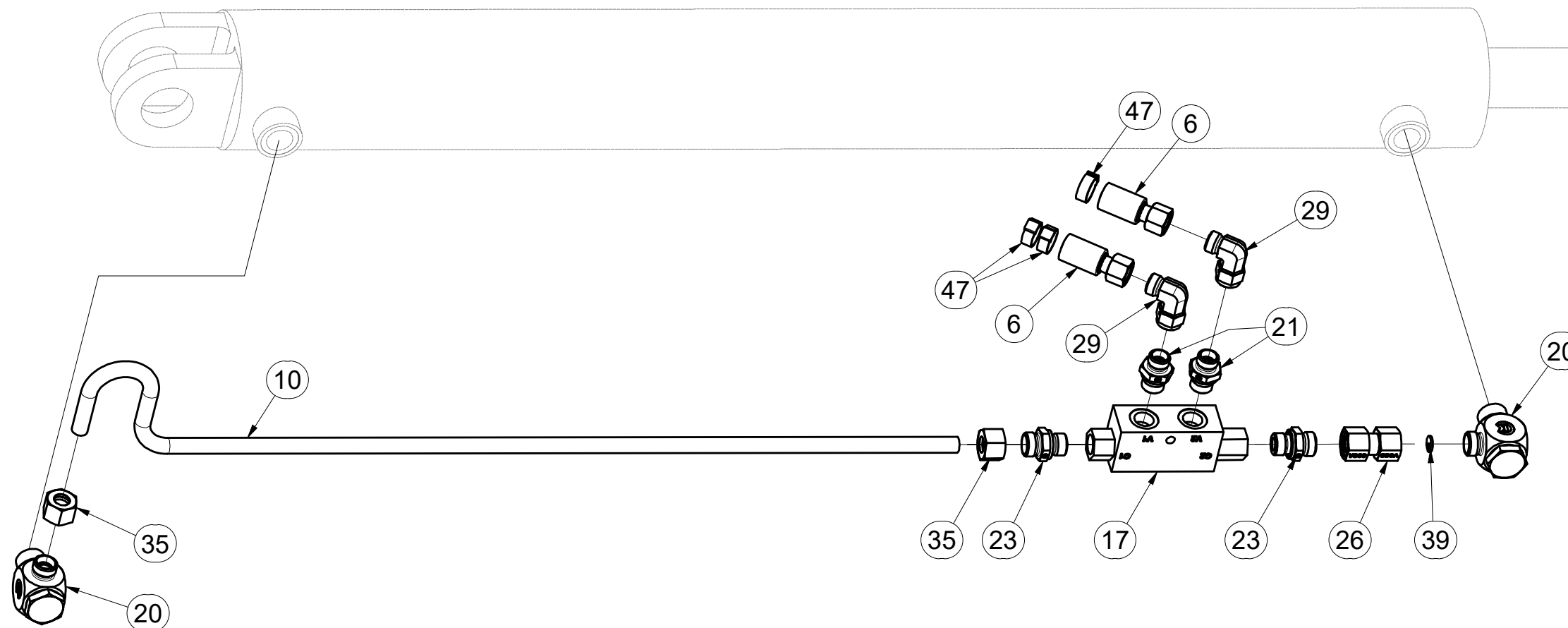
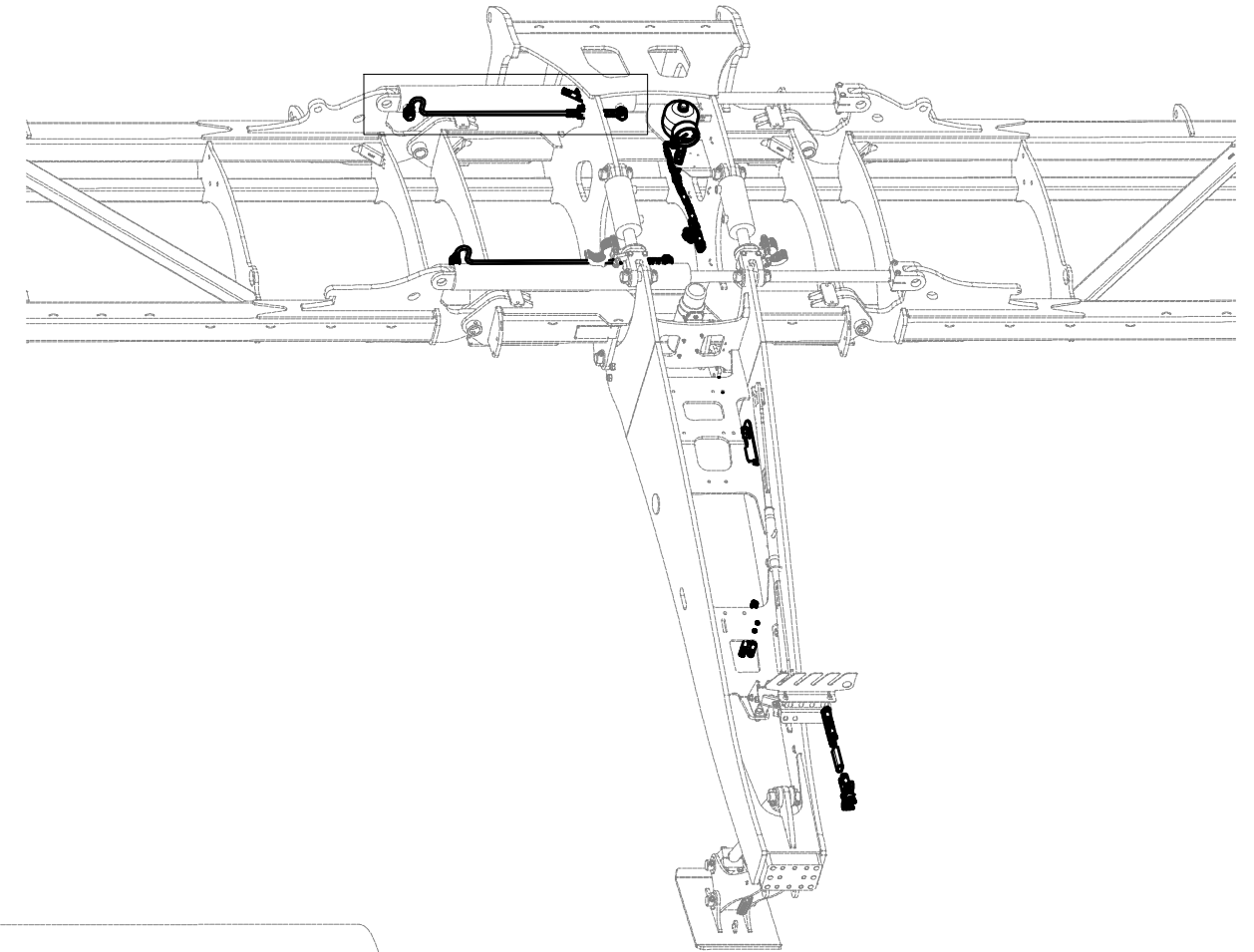

ⒸZ HYDRAULICKÝ ROZVOD SKLÁPĚNÍ

Ⓓ HYDRAULISCHE VERTEILUNG KLAPPMECHANISMUS

Ⓕ CONDUIT HYDRAULIQUE DU BASCULEMENT

ⒸB HYDRAULIC FOLDING DISTRIBUTION

ⒸU ГИДРАВЛИЧЕСКОЕ РАСПРЕДЕЛЕНИЕ СКЛАДЫВАНИЯ

ⒸL HYDRAULICZNY PRZEWÓD SKŁADANIA



**VZ00017640**

| Pos. | Part Number | Pcs. |
|------|-------------|------|
| 4    | m07647      | 5    |
| 10   | m16714      | 2    |
| 17   | m11103      | 2    |
| 20   | m20912      | 4    |
| 21   | m06528      | 8    |
| 23   | m06320      | 4    |
| 26   | m22306      | 2    |
| 29   | m06803      | 11   |
| 35   | m17321      | 4    |
| 39   | m10774      | 2    |
| 47   | m11294      | 42   |

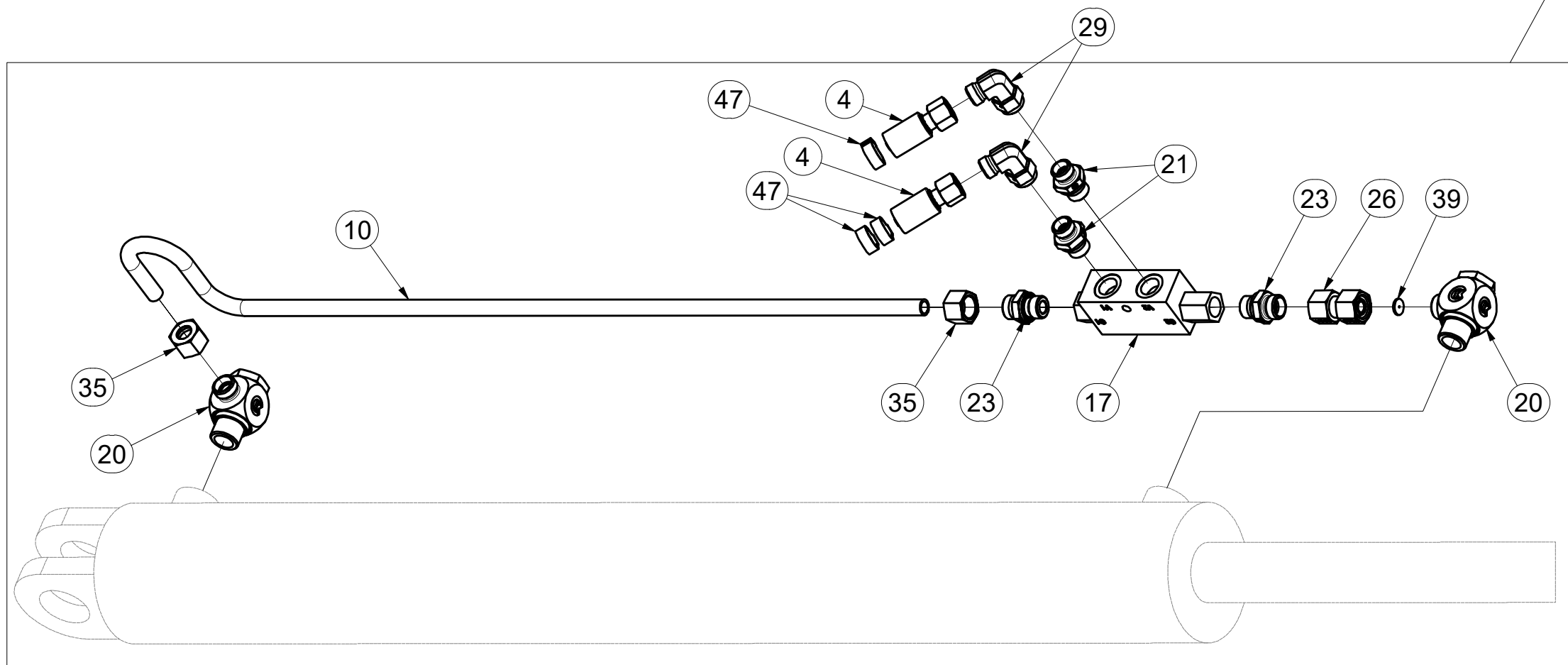
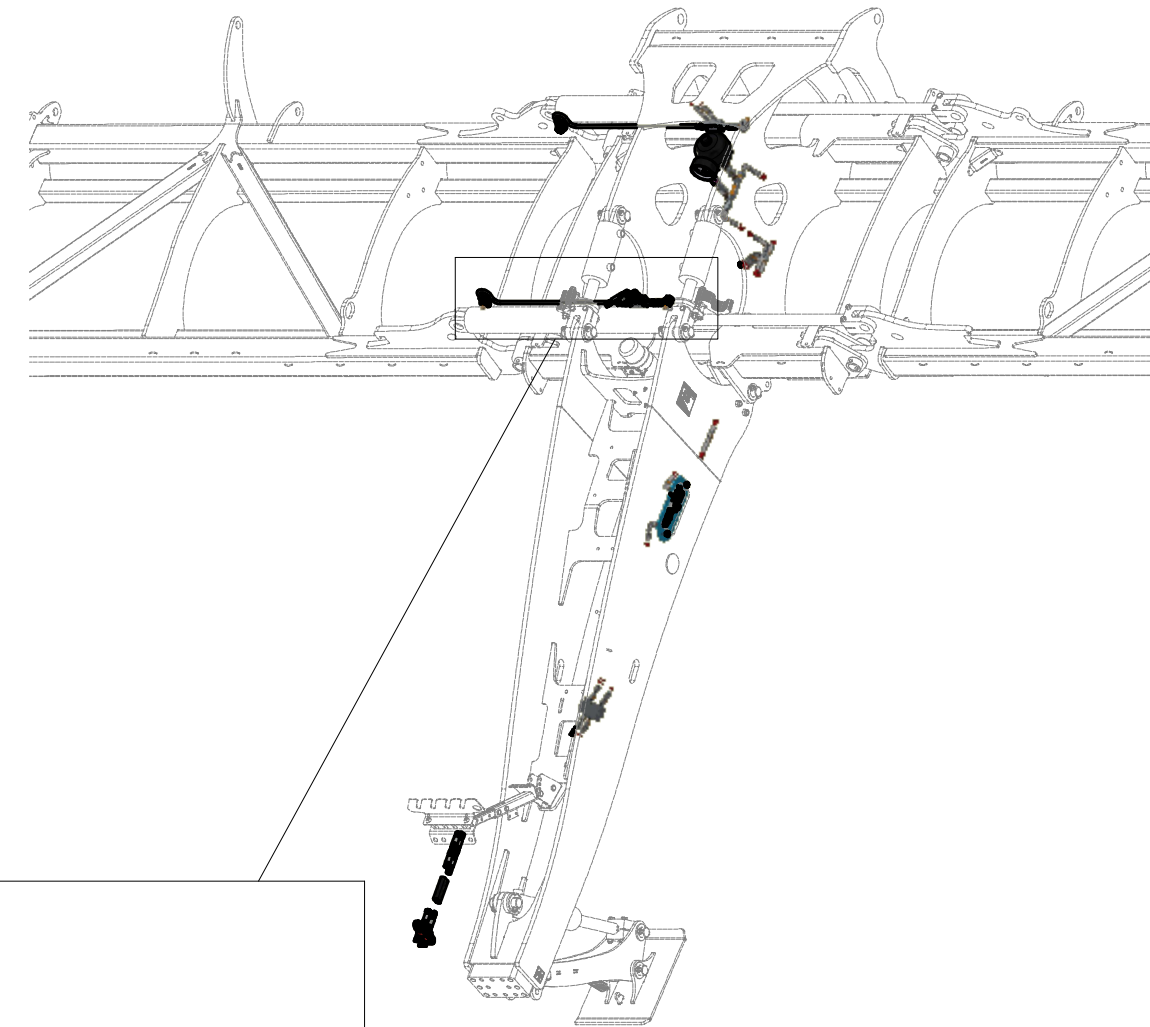

ⒸZ HYDRAULICKÝ ROZVOD - ZAHLUBOVÁNÍ

Ⓓ HYDRAULISCHE VERTEILUNG - EINSENKUNG

Ⓕ CONDUIT HYDRAULIQUE - L'ENFONCEMENT

ⒸB HYDRAULIC DISTRIBUTION - RECESSING

ⒸR ГИДРАВЛИЧЕСКОЕ РАСПРЕДЕЛЕНИЕ - ЗАГЛУБЛЕНИЕ

ⒸL HYDRAULICZNY PRZEWÓD - ZAGŁĘBIENIA

**Farmet**

**VZ00017764**

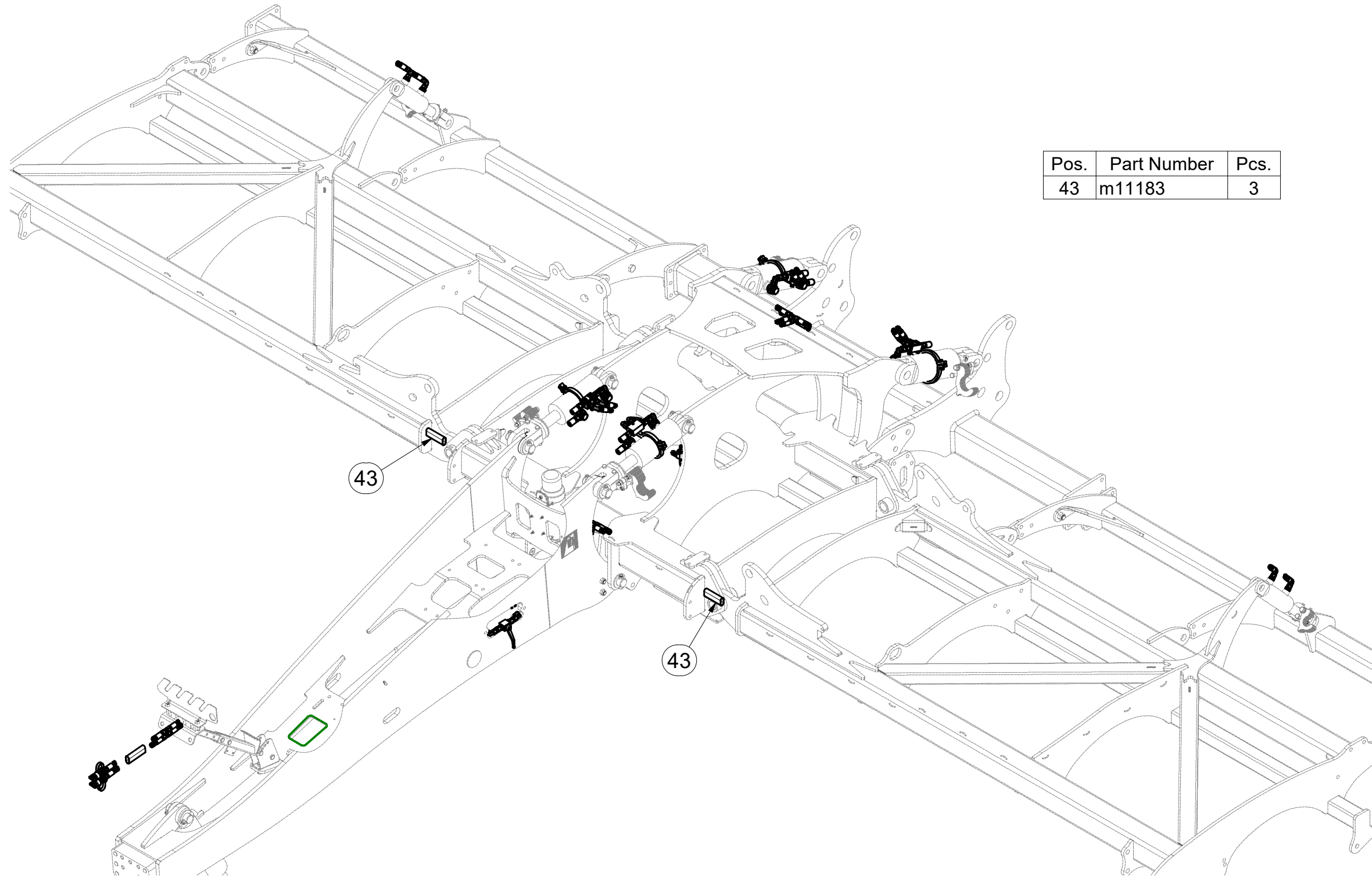

| Pos. | Part Number | Pcs. |
|------|-------------|------|
| 43   | m11183      | 3    |

ⒸZ HYDRAULICKÝ ROZVOD - ZAHLUBOVÁNÍ

Ⓓ HYDRAULISCHE VERTEILUNG - EINSENKUNG

Ⓕ CONDUIT HYDRAULIQUE - L'ENFONCEMENT

ⒸB HYDRAULIC DISTRIBUTION - RECESSING

ⒸU ГИДРАВЛИЧЕСКОЕ РАСПРЕДЕЛЕНИЕ - ЗАГЛУБЛЕНИЕ

ⒸL HYDRAULICZNY PRZEWÓD - ZAGŁĘBIENIA



**VZ00017764**

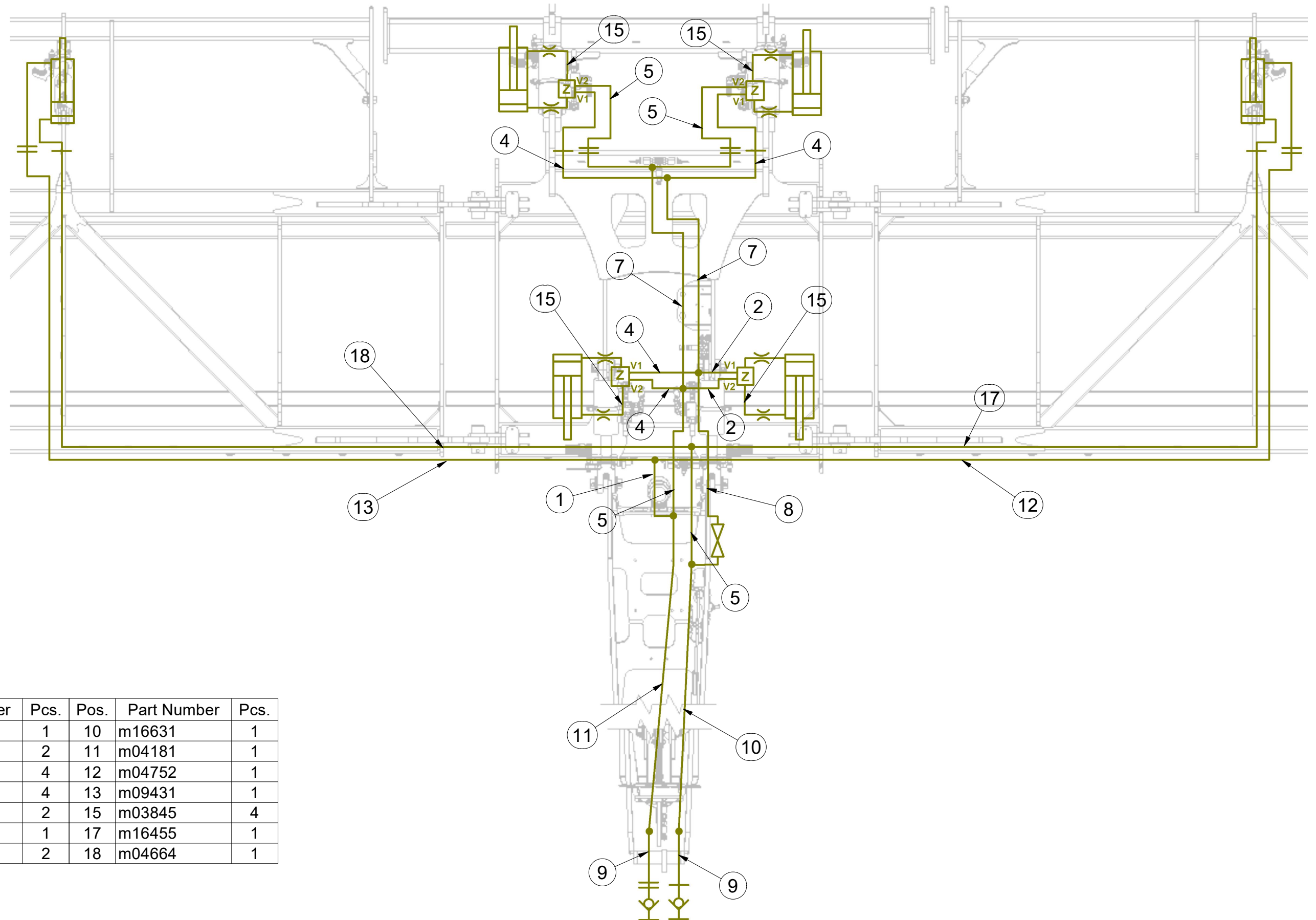

| Pos. | Part Number | Pcs. | Pos. | Part Number | Pcs. |
|------|-------------|------|------|-------------|------|
| 1    | m17441      | 1    | 10   | m16631      | 1    |
| 2    | m09628      | 2    | 11   | m04181      | 1    |
| 4    | m07909      | 4    | 12   | m04752      | 1    |
| 5    | m04033      | 4    | 13   | m09431      | 1    |
| 7    | m07647      | 2    | 15   | m03845      | 4    |
| 8    | m03952      | 1    | 17   | m16455      | 1    |
| 9    | m11696      | 2    | 18   | m04664      | 1    |

Ⓒ HYDRAULICKÝ ROZVOD - ZAHLUBOVÁNÍ

Ⓓ HYDRAULISCHE VERTEILUNG - EINSENKUNG

Ⓕ CONDUIT HYDRAULIQUE - L'ENFONCEMENT

Ⓖ HYDRAULIC DISTRIBUTION - RECESSING

Ⓡ ГИДРАВЛИЧЕСКОЕ РАСПРЕДЕЛЕНИЕ - ЗАГЛУБЛЕНИЕ

Ⓟ HYDRAULICZNY PRZEWÓD - ZAGŁĘBIENIA



**VZ00017764**

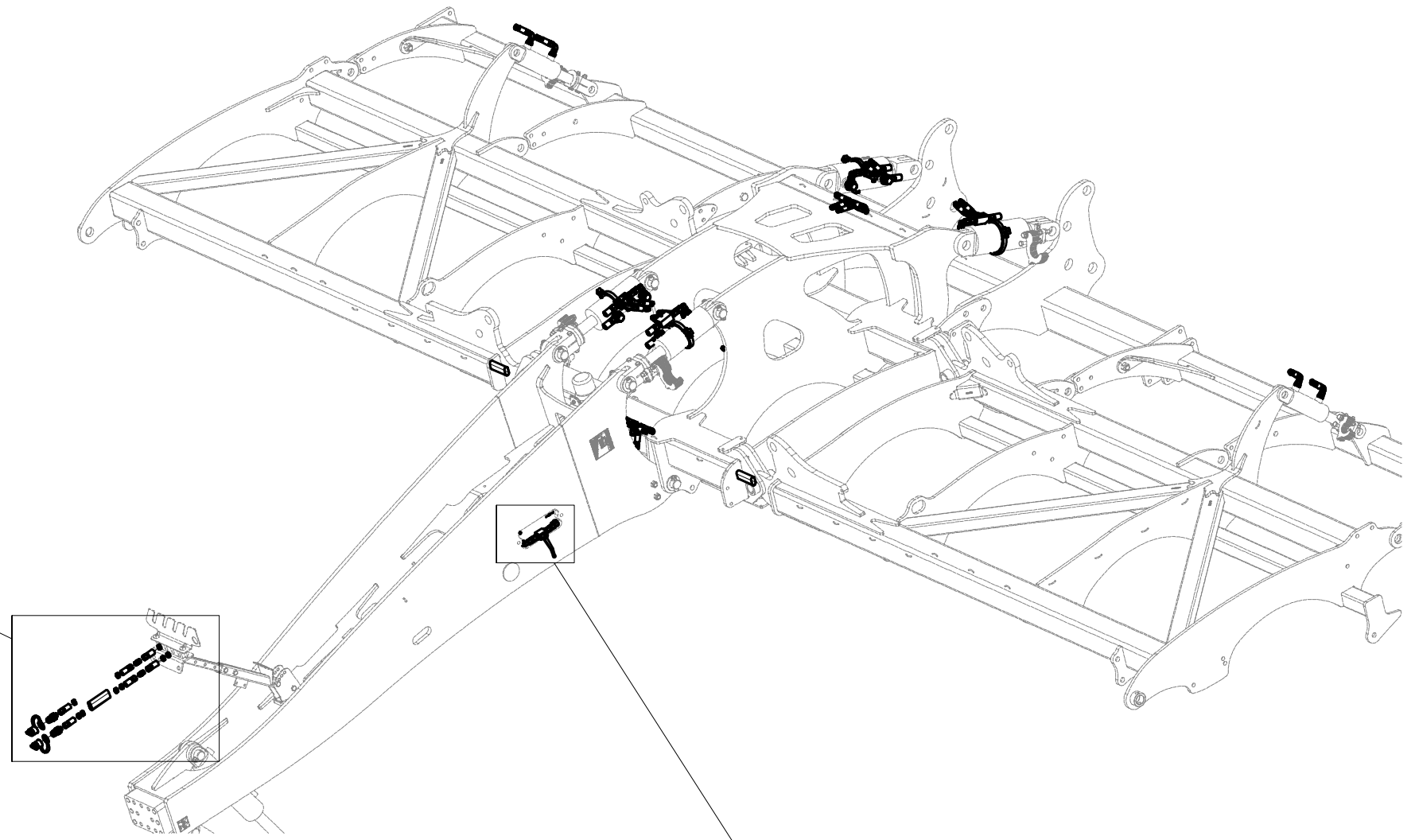
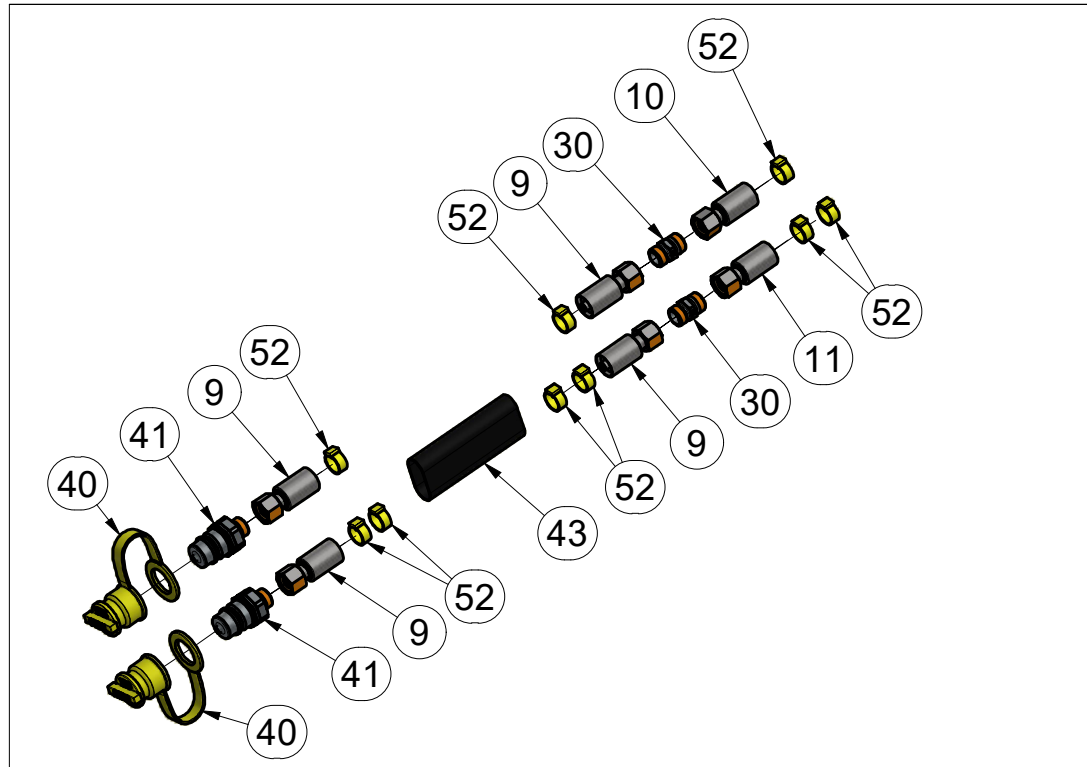

| Pos. | Part Number | Pcs. |
|------|-------------|------|
| 5    | m04033      | 4    |
| 8    | m03952      | 1    |
| 9    | m11696      | 2    |
| 10   | m16631      | 1    |
| 11   | m04181      | 1    |
| 21   | m04623      | 1    |
| 30   | m03213      | 2    |
| 31   | m06803      | 16   |
| 33   | m22305      | 2    |
| 34   | m07567      | 3    |
| 37   | m08391      | 2    |
| 40   | m04023      | 2    |
| 41   | m03849      | 2    |
| 43   | m11183      | 3    |
| 52   | m11289      | 68   |

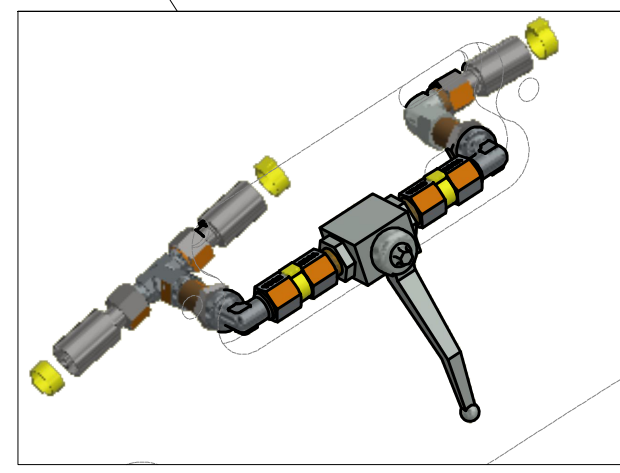
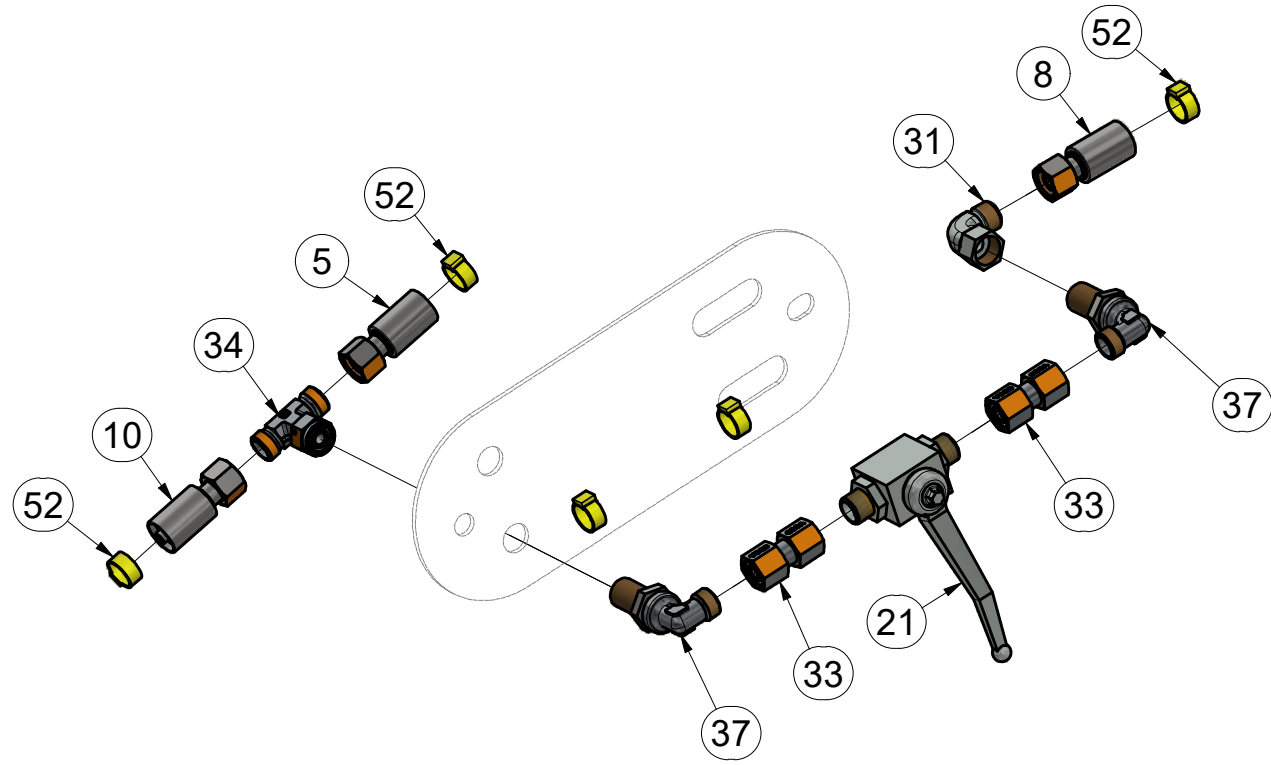



ⒸZ HYDRAULICKÝ ROZVOD - ZAHLUBOVÁNÍ

Ⓓ HYDRAULISCHE VERTEILUNG - EINSENKUNG

Ⓕ CONDUIT HYDRAULIQUE - L'ENFONCEMENT

ⒸB HYDRAULIC DISTRIBUTION - RECESSING

ⒸU ГИДРАВЛИЧЕСКОЕ РАСПРЕДЕЛЕНИЕ - ЗАГЛУБЛЕНИЕ

ⒸL HYDRAULICZNY PRZEWÓD - ZAGŁĘBIENIA



**VZ00017764**

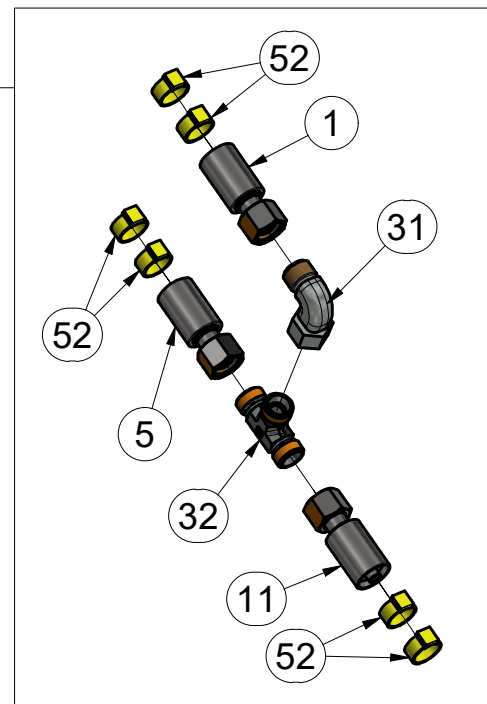
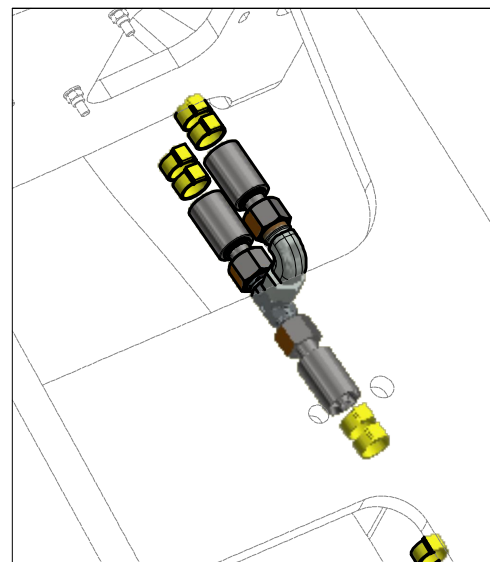
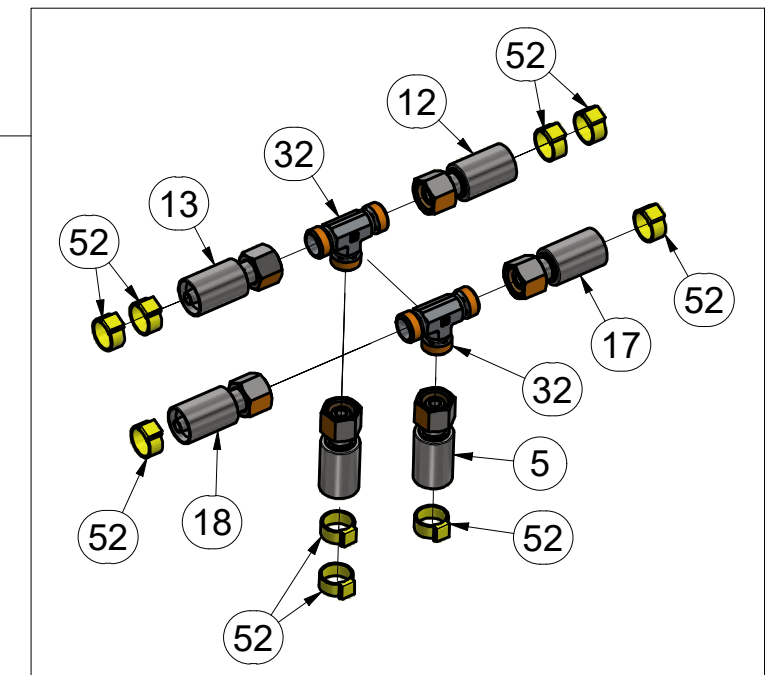
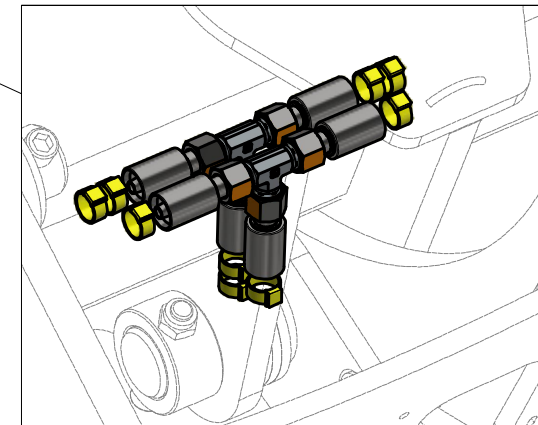
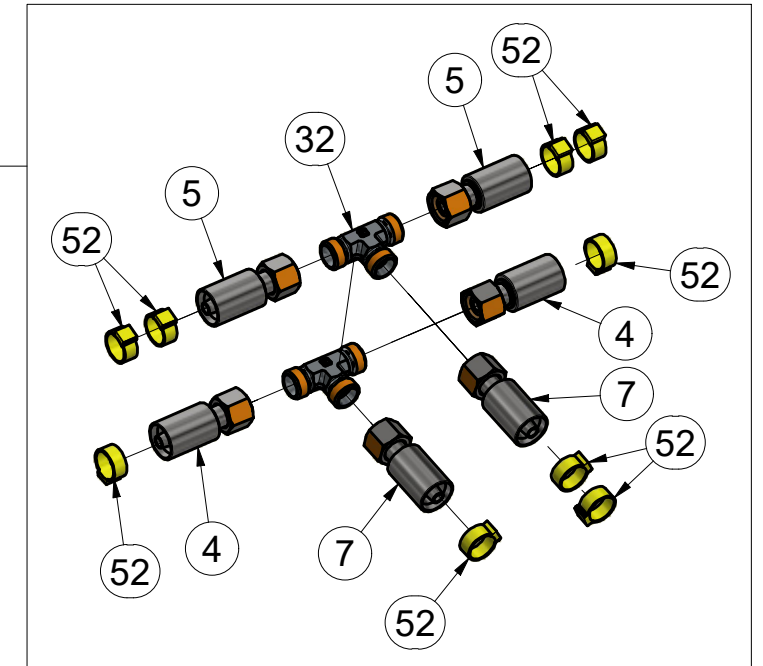
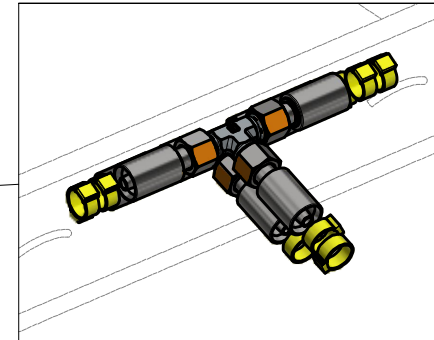
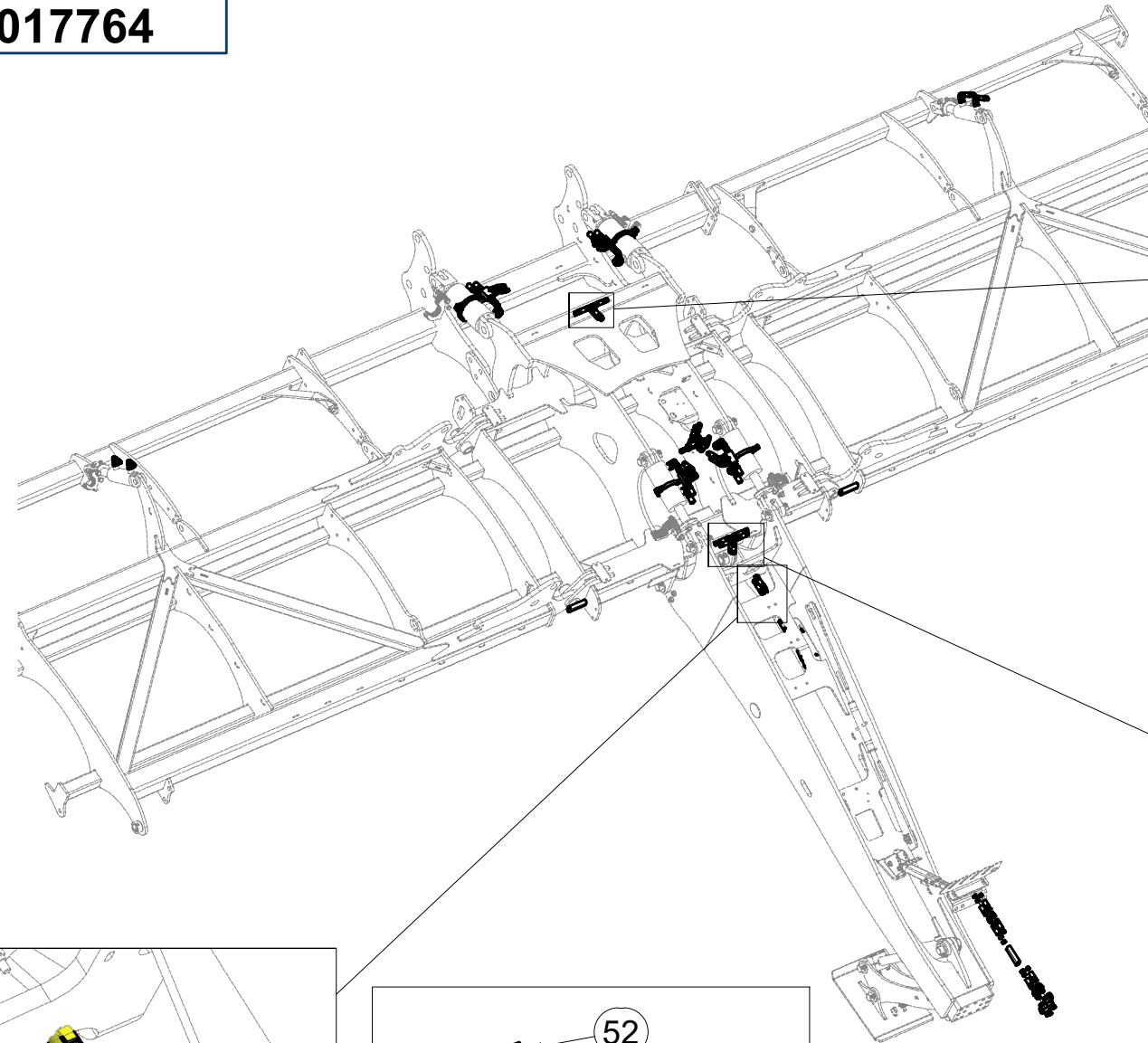

| Pos. | Part Number | Pcs. | Pos. | Part Number | Pcs. |
|------|-------------|------|------|-------------|------|
| 1    | m17441      | 1    | 13   | m09431      | 1    |
| 4    | m07909      | 4    | 17   | m16455      | 1    |
| 5    | m04033      | 4    | 18   | m04664      | 1    |
| 7    | m07647      | 2    | 31   | m06803      | 16   |
| 11   | m04181      | 1    | 32   | m03889      | 7    |
| 12   | m04752      | 1    | 52   | m11289      | 68   |

ⒸZ HYDRAULICKÝ ROZVOD - ZAHLUBOVÁNÍ

Ⓓ HYDRAULISCHE VERTEILUNG - EINSENKUNG

Ⓕ CONDUIT HYDRAULIQUE - L'ENFONCEMENT

ⒸGB HYDRAULIC DISTRIBUTION - RECESSING

ⒸRU ГИДРАВЛИЧЕСКОЕ РАСПРЕДЕЛЕНИЕ - ЗАГЛУБЛЕНИЕ

ⒸPL HYDRAULICZNY PRZEWÓD - ZAGŁĘBIENIA



**VZ00017764**

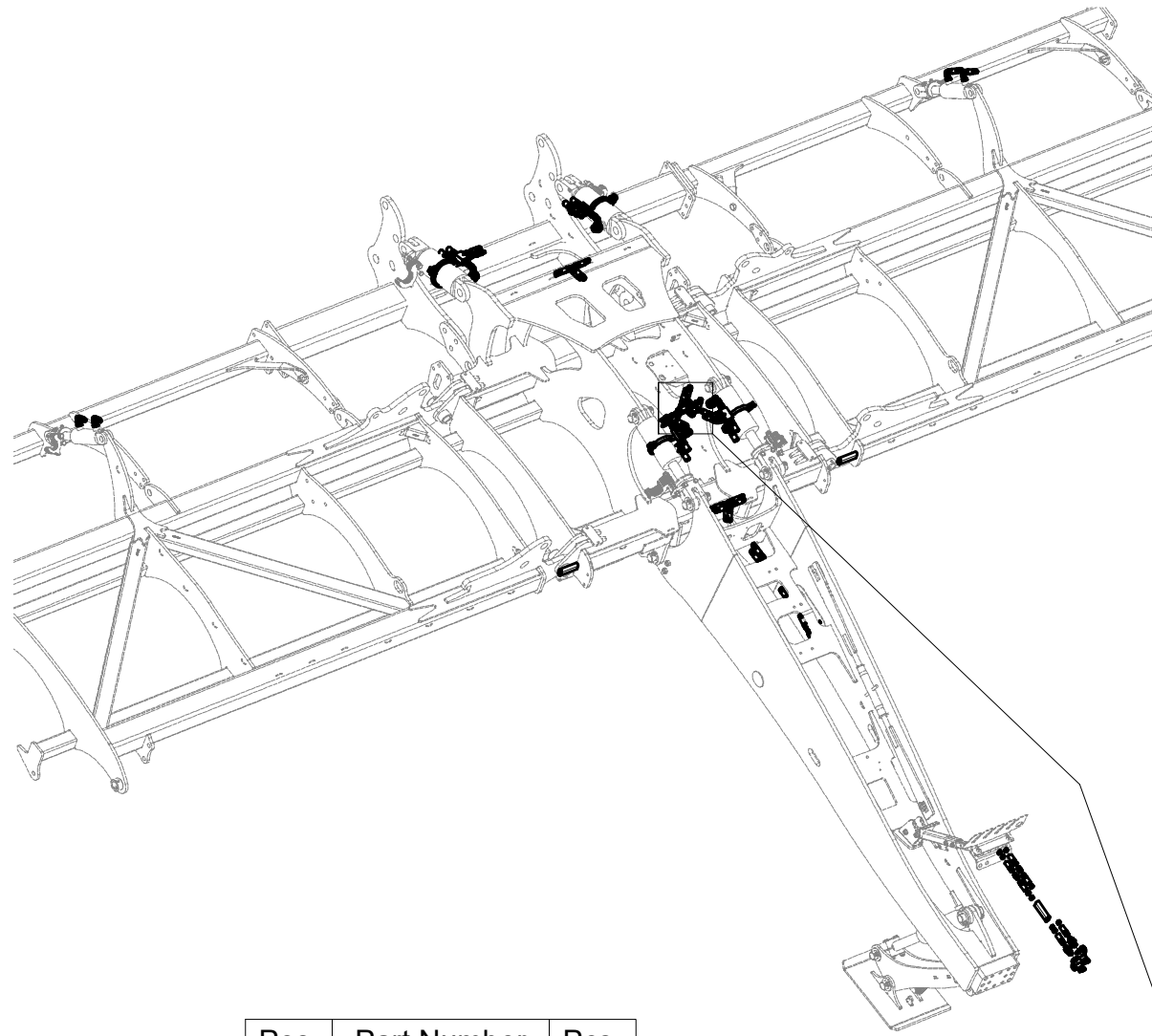

| Pos. | Part Number | Pcs. |
|------|-------------|------|
| 2    | m09628      | 2    |
| 4    | m07909      | 4    |
| 5    | m04033      | 4    |
| 7    | m07647      | 2    |
| 8    | m03952      | 1    |
| 31   | m06803      | 16   |
| 32   | m03889      | 7    |
| 34   | m07567      | 3    |
| 52   | m11289      | 68   |

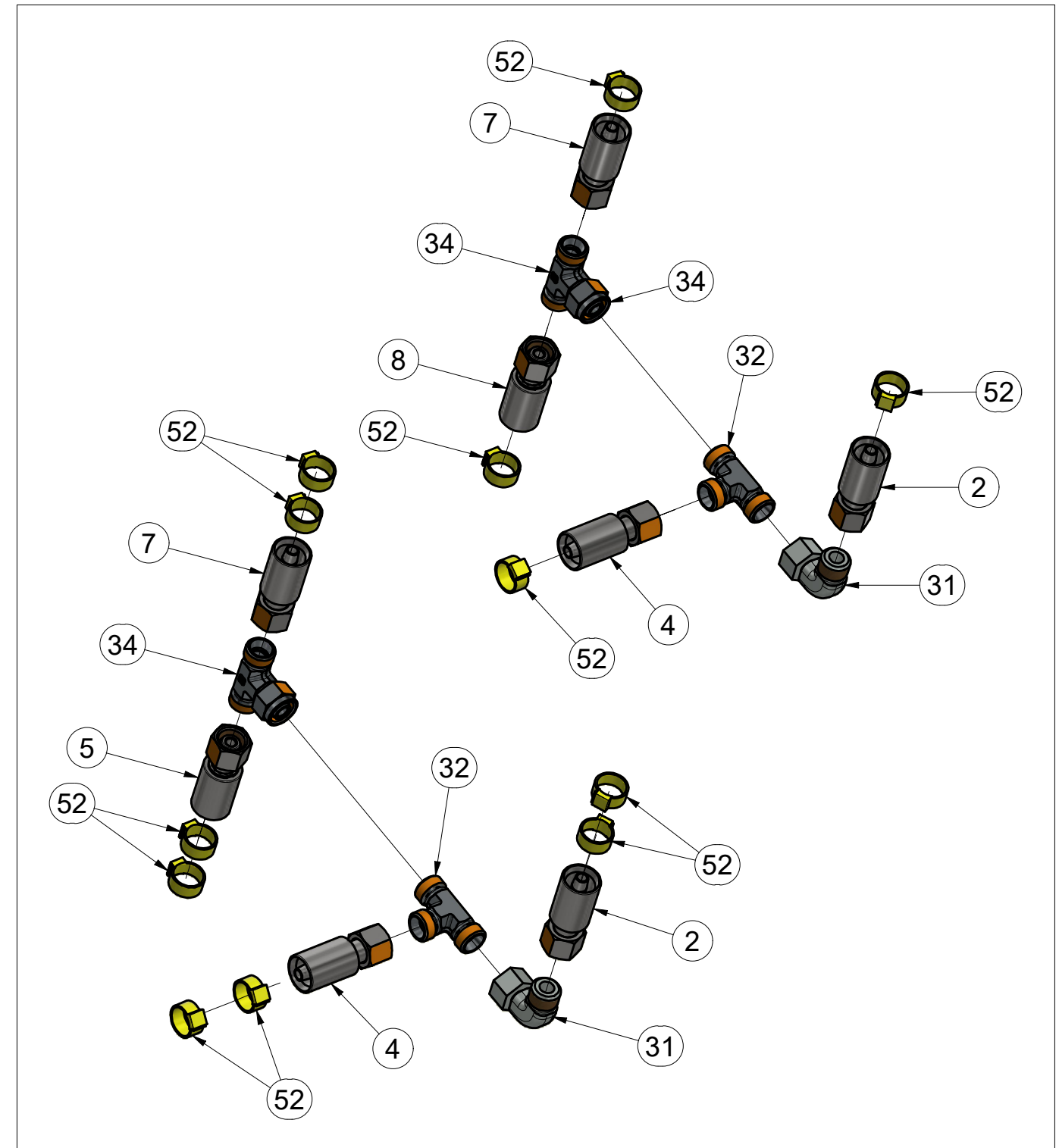
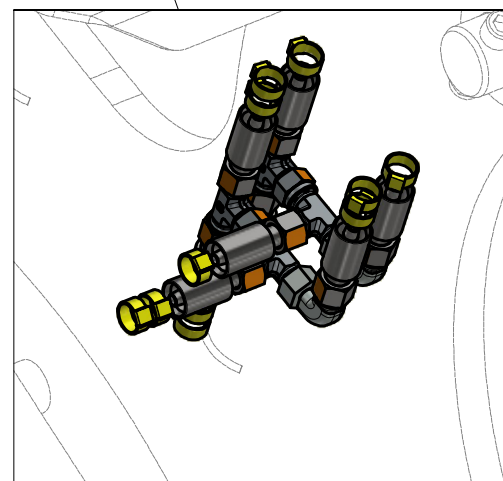

ⒸZ HYDRAULICKÝ ROZVOD - ZAHLUBOVÁNÍ

Ⓓ HYDRAULISCHE VERTEILUNG - EINSENKUNG

Ⓕ CONDUIT HYDRAULIQUE - L'ENFONCEMENT

ⒸB HYDRAULIC DISTRIBUTION - RECESSING

ⒸU ГИДРАВЛИЧЕСКОЕ РАСПРЕДЕЛЕНИЕ - ЗАГЛУБЛЕНИЕ

ⒸL HYDRAULICZNY PRZEWÓD - ZAGŁĘBIENIA



**VZ00017764**

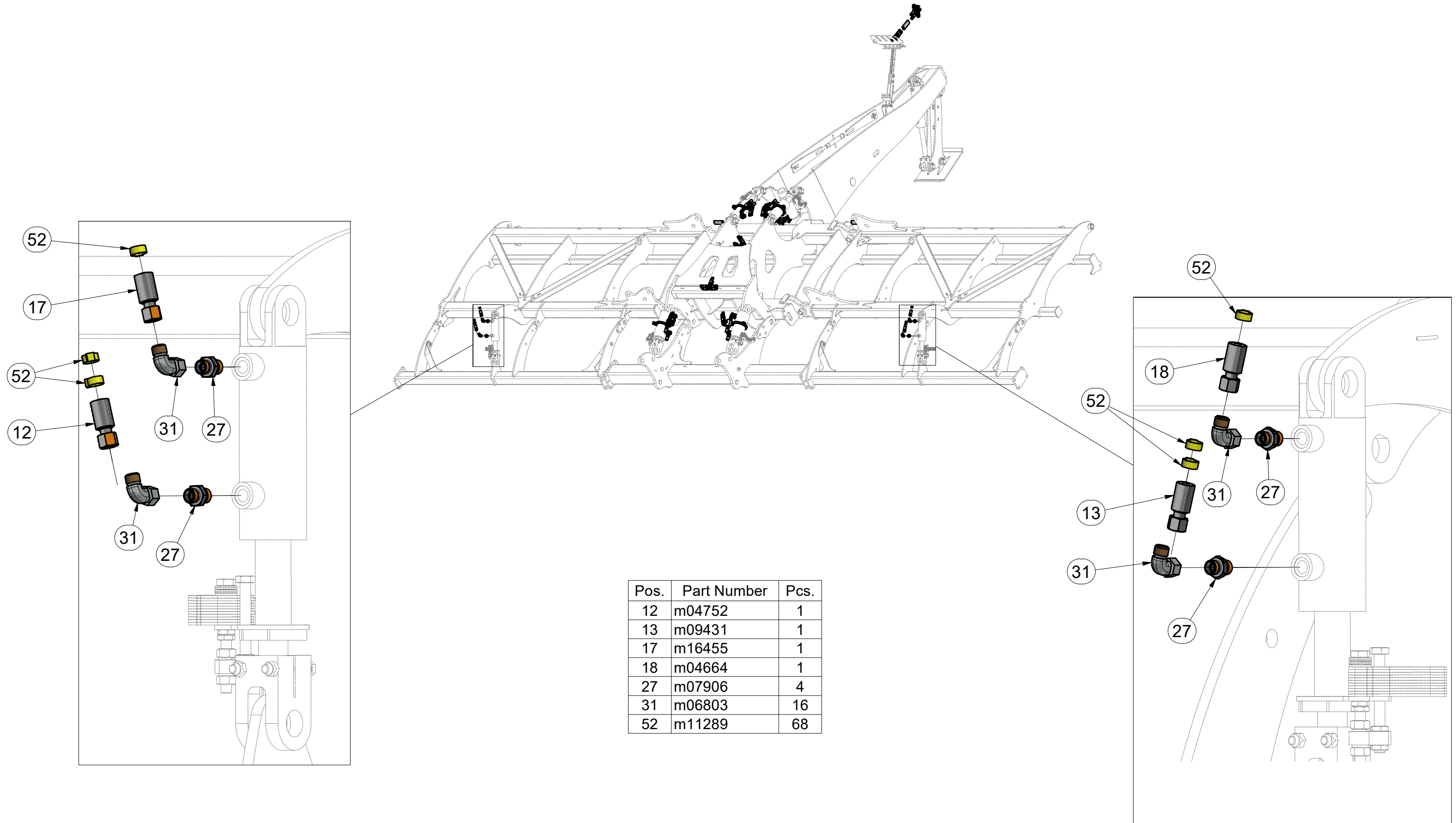

ⒸZ HYDRAULICKÝ ROZVOD - ZAHLUBOVÁNÍ

Ⓓ HYDRAULISCHE VERTEILUNG - EINSENKUNG

Ⓕ CONDUIT HYDRAULIQUE - L'ENFONCEMENT

ⒸB HYDRAULIC DISTRIBUTION - RECESSING

ⒸU ГИДРАВЛИЧЕСКОЕ РАСПРЕДЕЛЕНИЕ - ЗАГЛУБЛЕНИЕ

ⒸL HYDRAULICZNY PRZEWÓD - ZAGŁĘBIENIA



**VZ00017764**

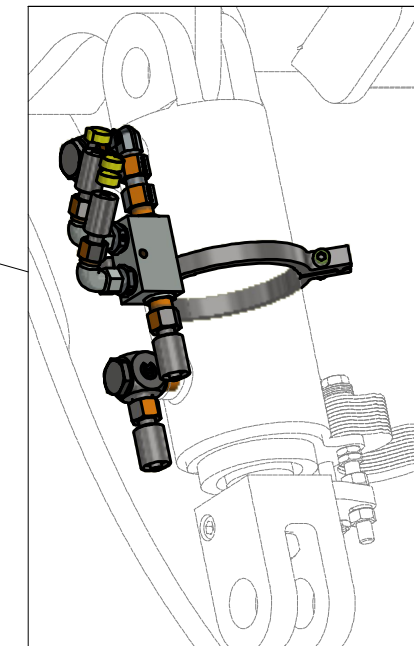
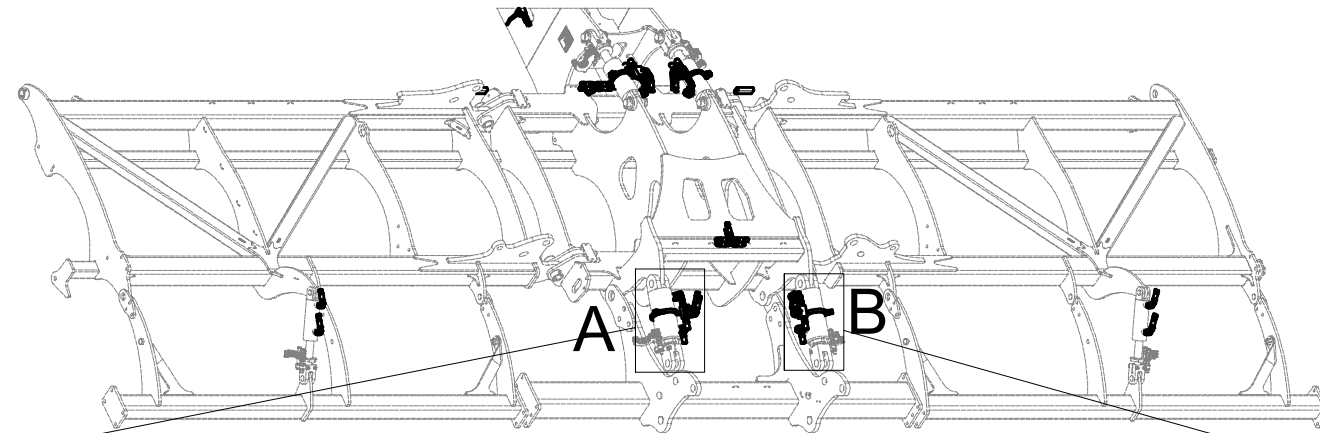
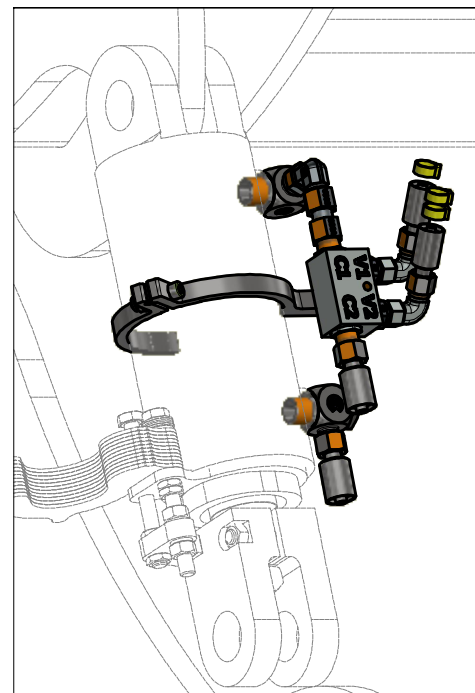

| Pos. | Part Number | Pcs. | Pos. | Part Number | Pcs. |
|------|-------------|------|------|-------------|------|
| 4    | m07909      | 4    | 31   | m06803      | 16   |
| 5    | m04033      | 4    | 35   | m22306      | 4    |
| 15   | m03845      | 4    | 36   | m07654      | 4    |
| 20   | m08083      | 4    | 45   | m10762      | 8    |
| 25   | m20912      | 8    | 52   | m11289      | 68   |
| 26   | m06528      | 8    | 61   | VZ00010112  | 2    |

**A**

**B**

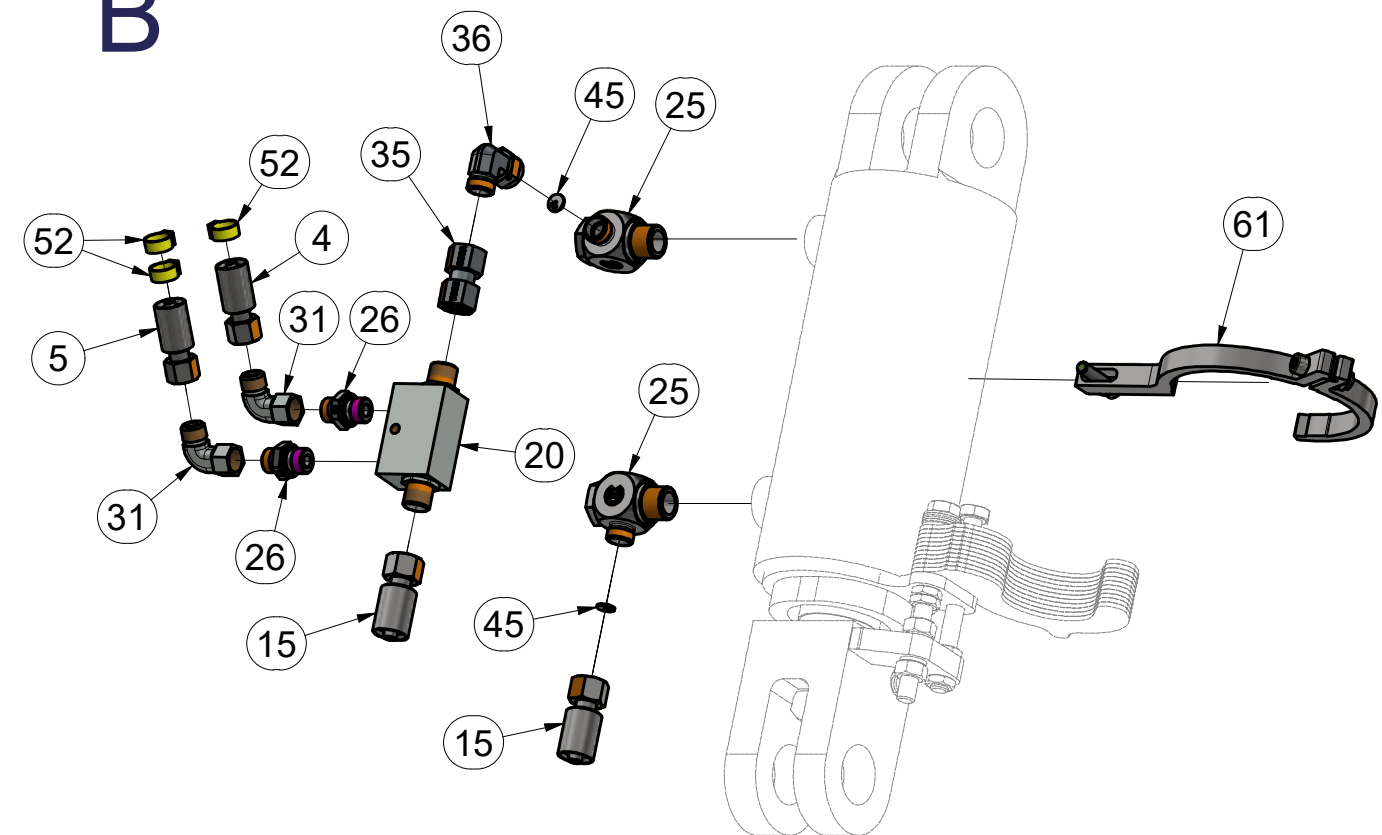
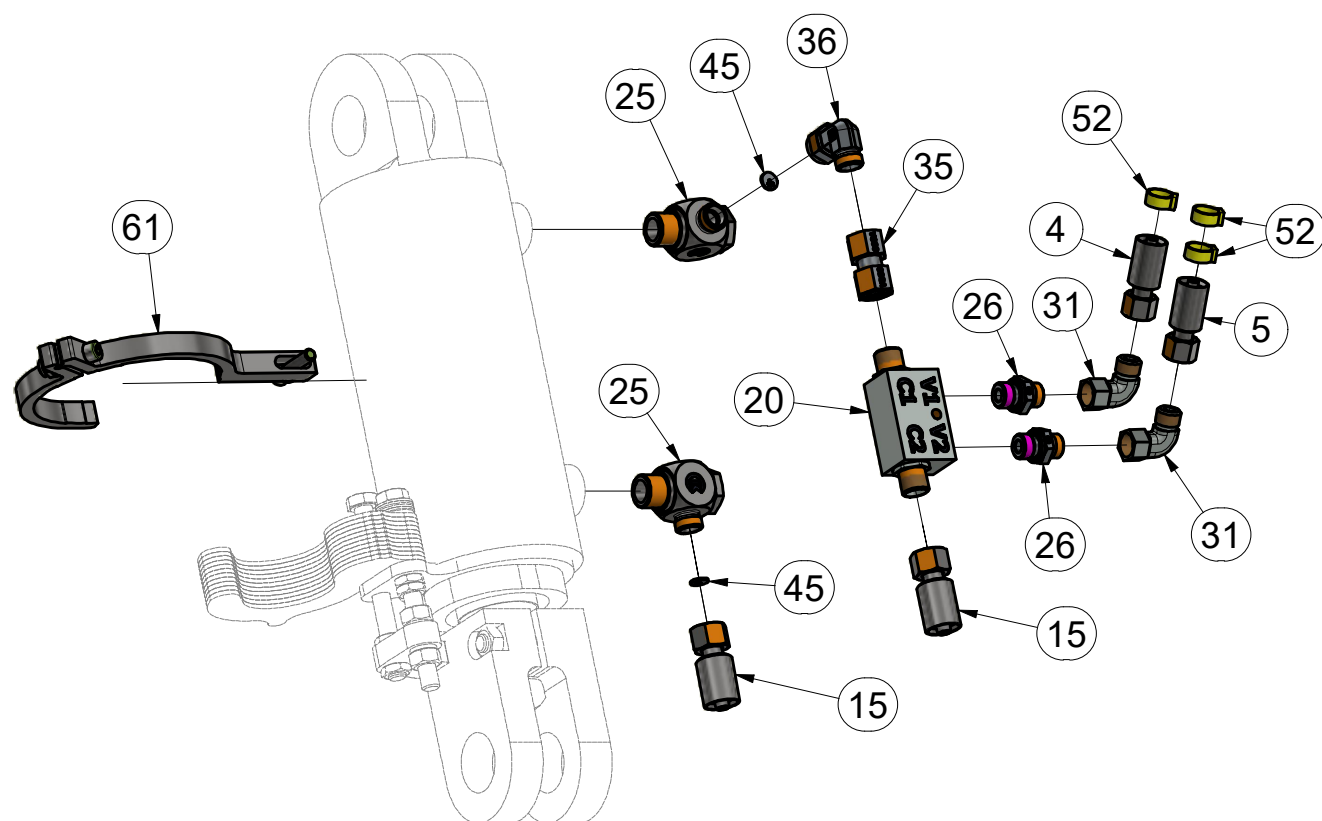

Ⓒ HYDRAULICKÝ ROZVOD - ZAHLUBOVÁNÍ

Ⓓ HYDRAULISCHE VERTEILUNG - EINSENKUNG

Ⓕ CONDUIT HYDRAULIQUE - L'ENFONCEMENT

Ⓖ HYDRAULIC DISTRIBUTION - RECESSING

Ⓔ ГИДРАВЛИЧЕСКОЕ РАСПРЕДЕЛЕНИЕ - ЗАГЛУБЛЕНИЕ

Ⓟ HYDRAULICZNY PRZEWÓD - ZAGŁĘBIENIA



**VZ00017764**

| Pos. | Part Number | Pcs. | Pos. | Part Number | Pcs. |
|------|-------------|------|------|-------------|------|
| 4    | m07909      | 4    | 35   | m22306      | 4    |
| 15   | m03845      | 4    | 36   | m07654      | 4    |
| 20   | m08083      | 4    | 45   | m10762      | 8    |
| 25   | m20912      | 8    | 52   | m11289      | 68   |
| 26   | m06528      | 8    | 60   | VZ00010409  | 2    |
| 31   | m06803      | 16   |      |             |      |

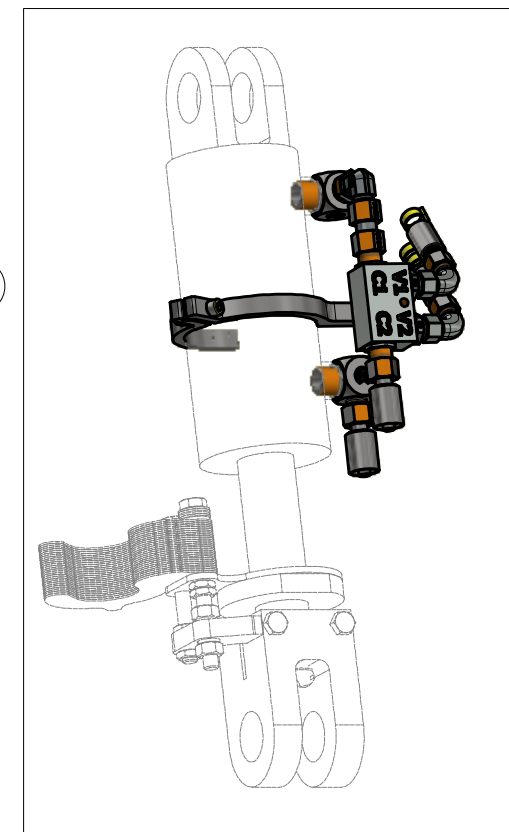
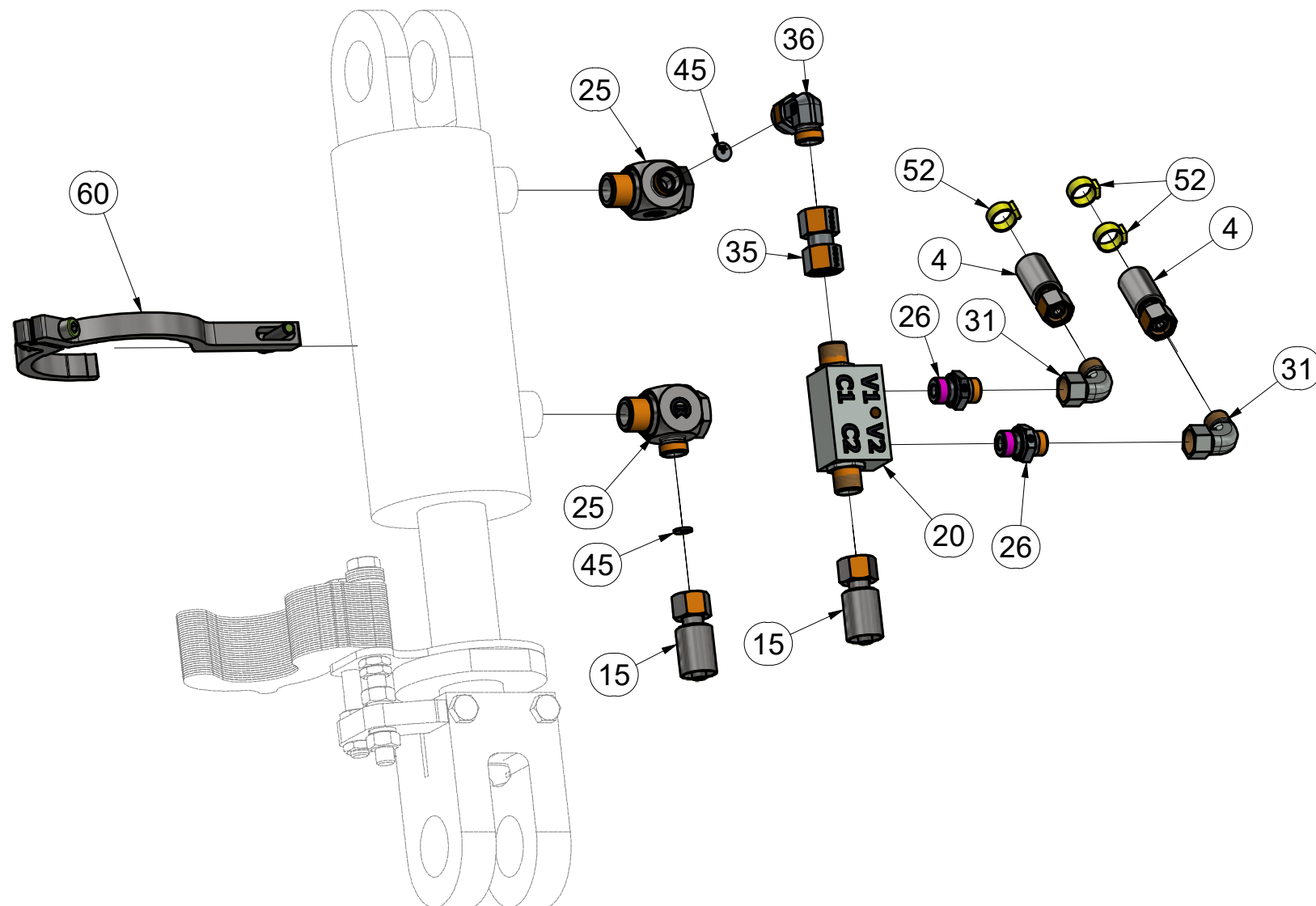
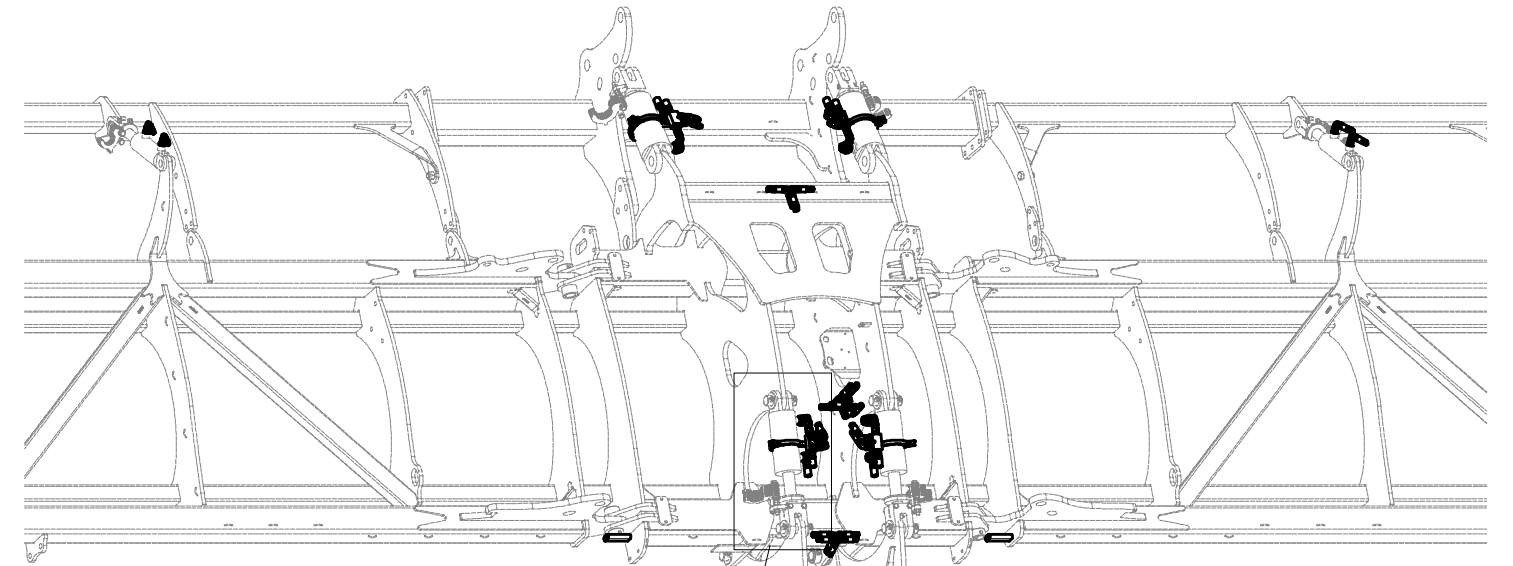

ⒸZ HYDRAULICKÝ ROZVOD - ZAHLUBOVÁNÍ

Ⓓ HYDRAULISCHE VERTEILUNG - EINSENKUNG

Ⓕ CONDUIT HYDRAULIQUE - L'ENFONCEMENT

ⒸB HYDRAULIC DISTRIBUTION - RECESSING

ⒸU ГИДРАВЛИЧЕСКОЕ РАСПРЕДЕЛЕНИЕ - ЗАГЛУБЛЕНИЕ

ⒸL HYDRAULICZNY PRZEWÓD - ZAGŁĘBIENIA

**Farmet**

**VZ00017764**

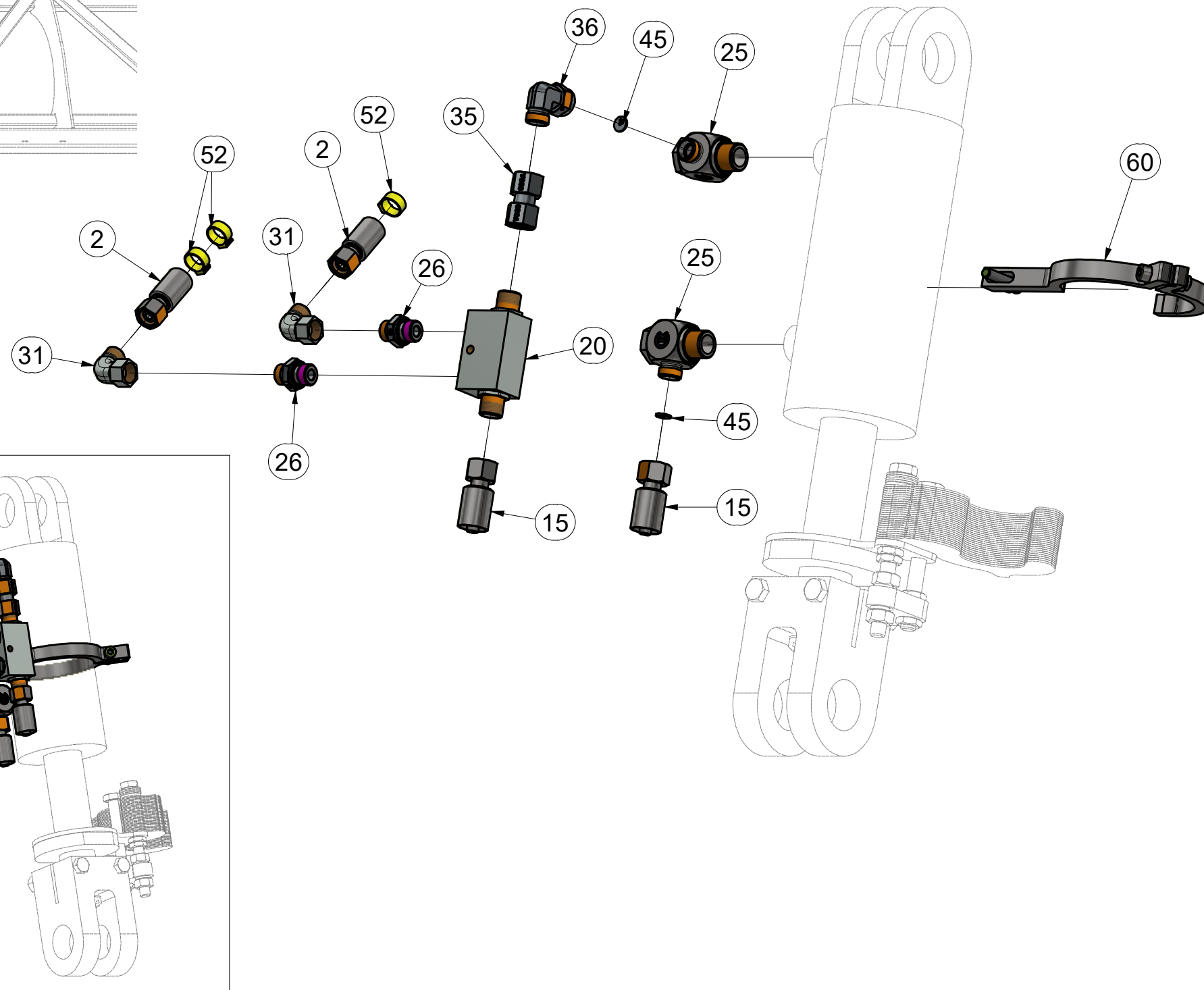
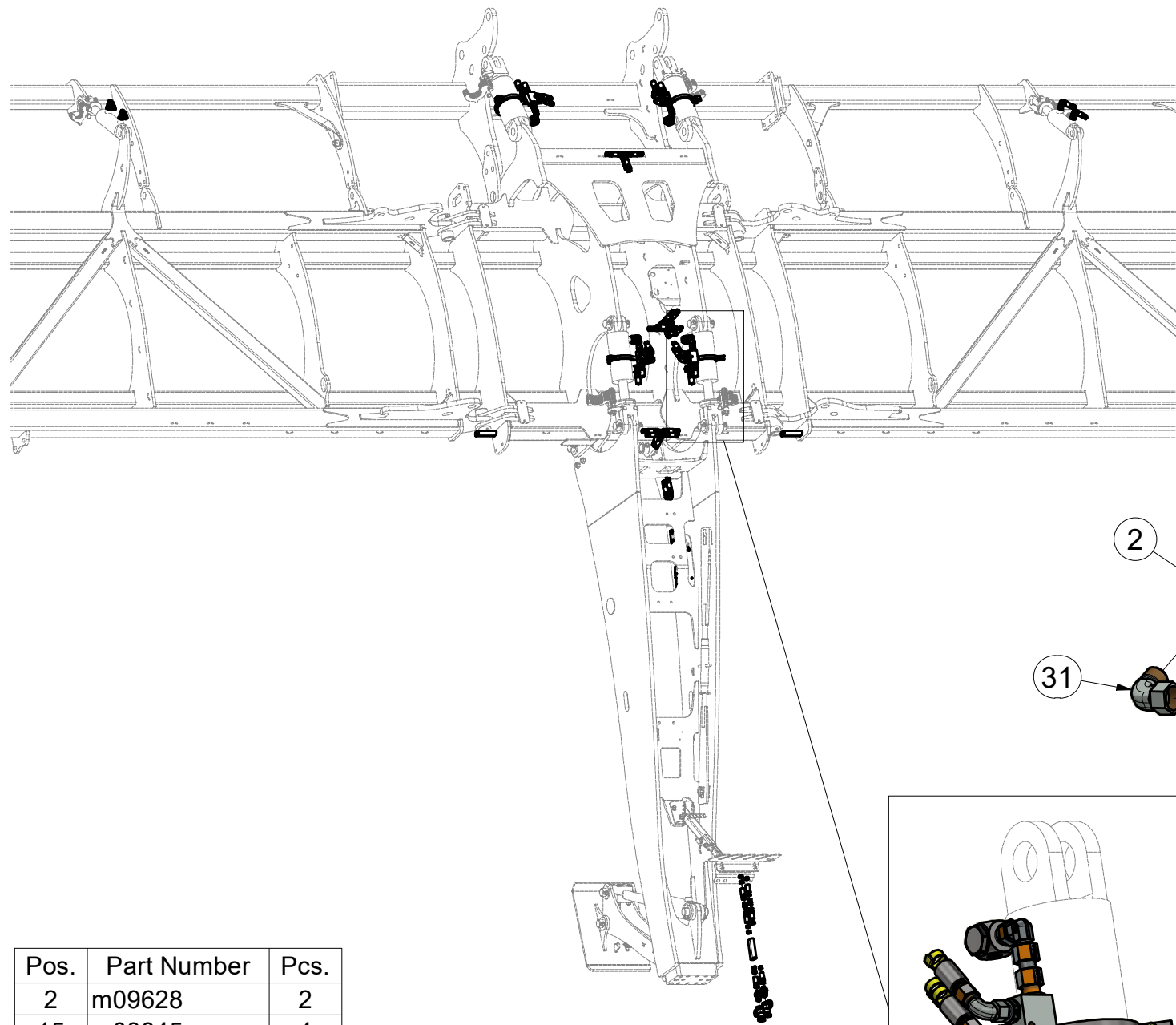

| Pos. | Part Number | Pcs. |
|------|-------------|------|
| 2    | m09628      | 2    |
| 15   | m03845      | 4    |
| 20   | m08083      | 4    |
| 25   | m20912      | 8    |
| 26   | m06528      | 8    |
| 31   | m06803      | 16   |
| 35   | m22306      | 4    |
| 36   | m07654      | 4    |
| 45   | m10762      | 8    |
| 52   | m11289      | 68   |
| 60   | VZ00010409  | 2    |

ⒸZ HYDRAULIKA STROJE

Ⓓ HYDRAULIK DER MASCHINE

Ⓕ HYDRAULIQUE DE LA MACHINE

ⒸB MACHINE HYDRAULICS

ⒸR ГИДРАВЛИКА МАШИНЫ

ⒸL HYDRAULIKA MASZYNY



**VZ00017842**

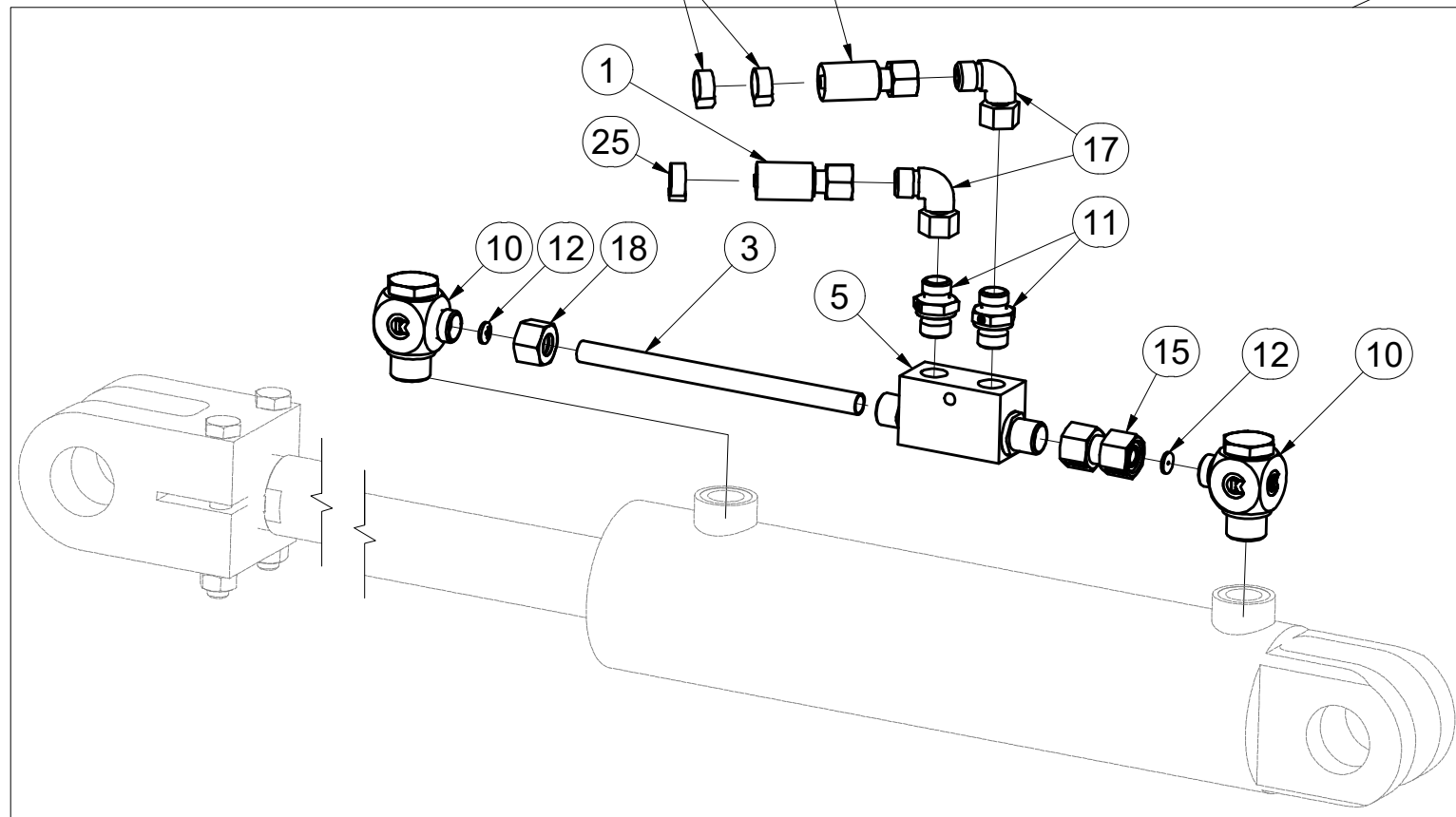
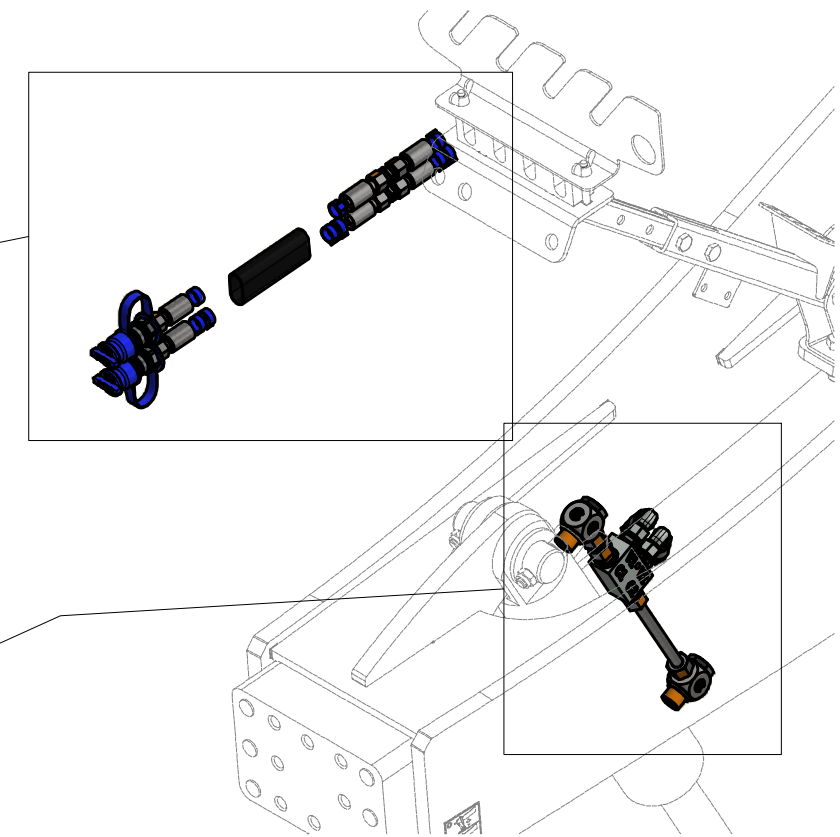
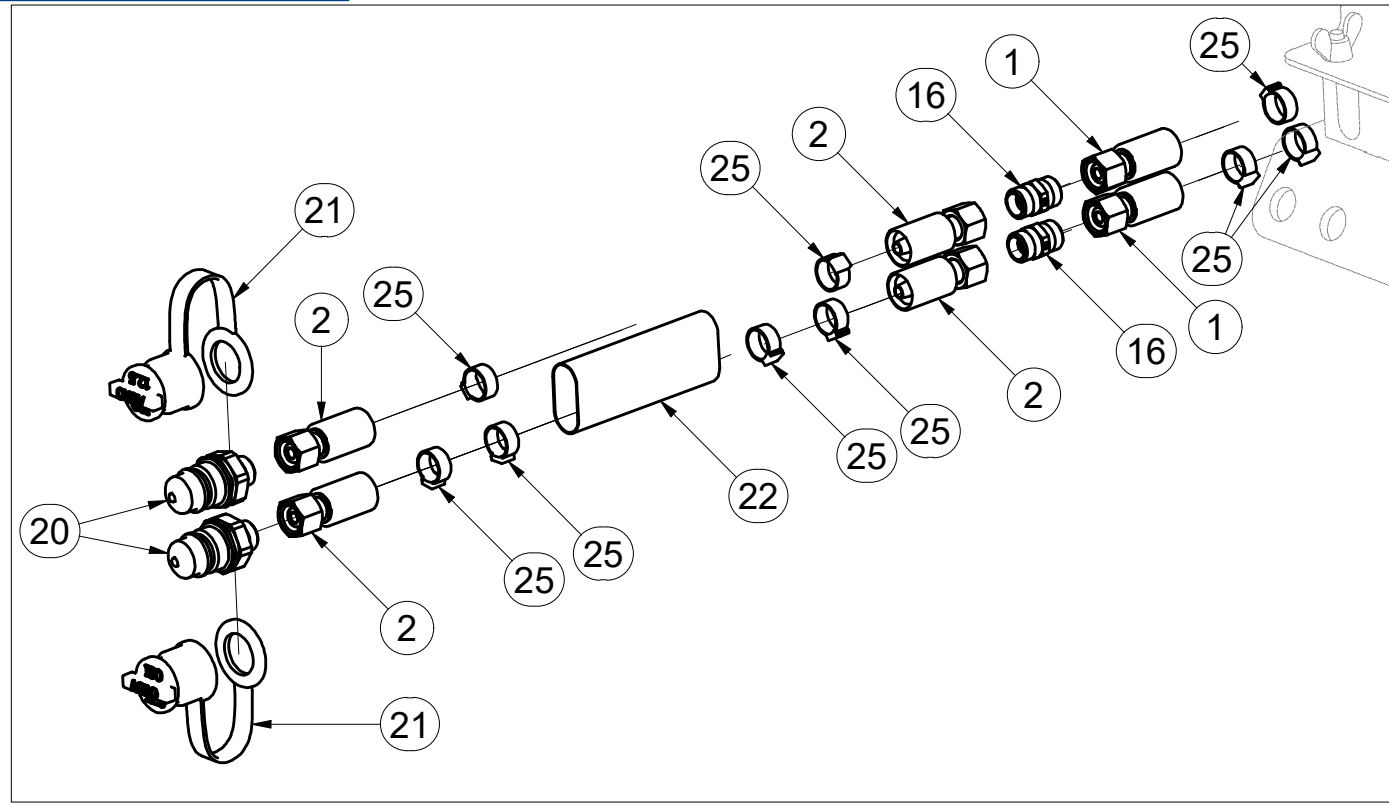

| Pos. | Part Number | Pcs. | Pos. | Part Number | Pcs. |
|------|-------------|------|------|-------------|------|
| 1    | m05762      | 2    | 16   | m03213      | 2    |
| 2    | m11696      | 2    | 17   | m06803      | 2    |
| 3    | m20005      | 1    | 18   | m17321      | 2    |
| 5    | m08083      | 1    | 20   | m03849      | 2    |
| 10   | m20912      | 2    | 21   | m03743      | 2    |
| 11   | m06528      | 2    | 22   | m11183      | 1    |
| 12   | m10776      | 2    | 25   | m11253      | 12   |
| 15   | m22306      | 1    |      |             |      |

Ⓒ PÍSTNICE 63/40-95

Ⓓ KOLBENSTANGE 63/40-95

Ⓕ TIGE DE PISTON 63/40-95

Ⓖ PISTON ROD 63/40-95

Ⓡ ЦИЛИНДР 63/40-95

Ⓟ TRZPIEŃ TŁOKA 63/40-95



**4015781**

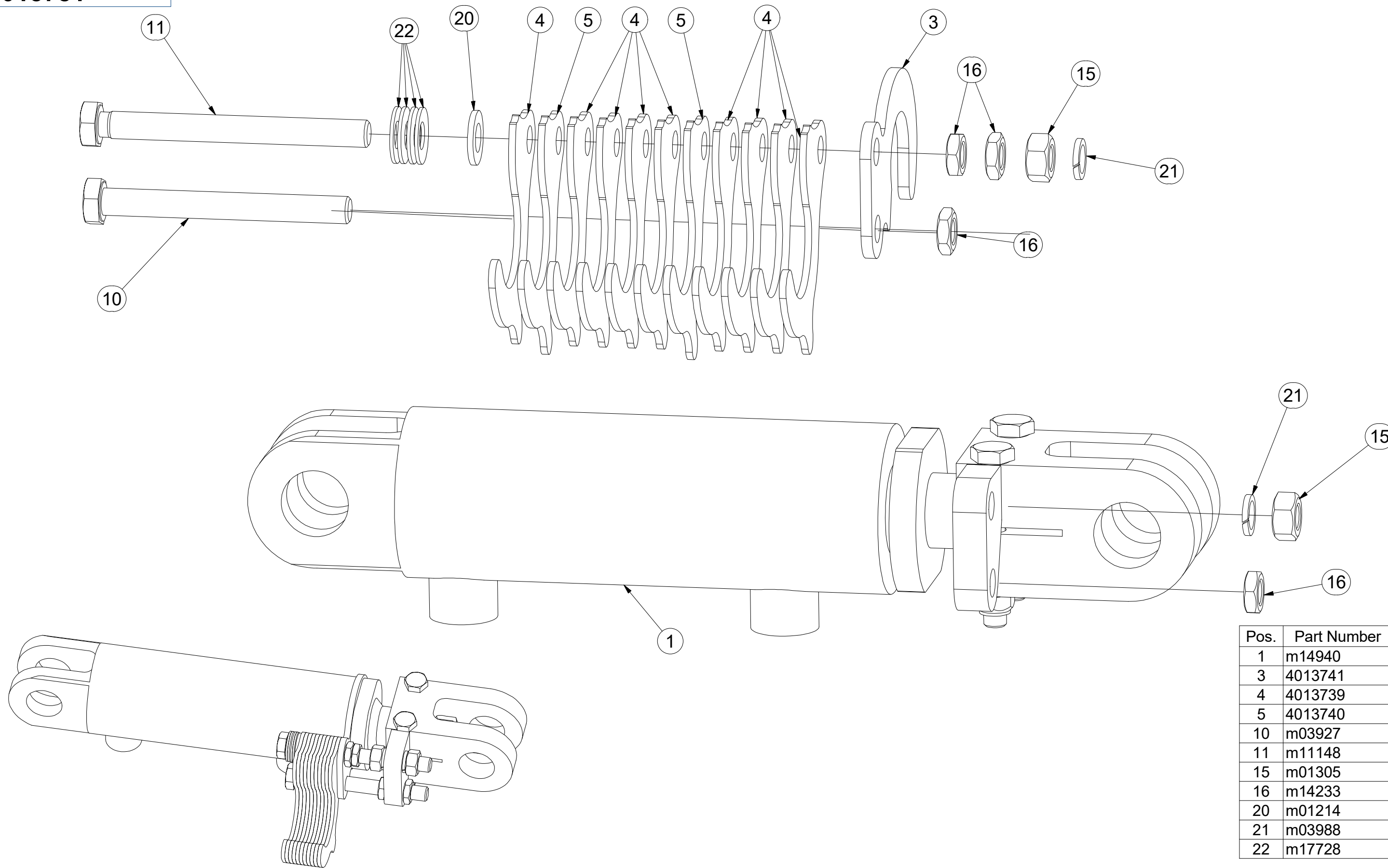

| Pos. | Part Number | Pcs. |
|------|-------------|------|
| 1    | m14940      | 1    |
| 3    | 4013741     | 1    |
| 4    | 4013739     | 9    |
| 5    | 4013740     | 2    |
| 10   | m03927      | 1    |
| 11   | m11148      | 1    |
| 15   | m01305      | 2    |
| 16   | m14233      | 4    |
| 20   | m01214      | 1    |
| 21   | m03988      | 2    |
| 22   | m17728      | 4    |



Ⓒ PÍSTNICE 90/45-100

Ⓓ KOLBENSTANGE 90/45-100

Ⓕ TIGE DE PISTON 90/45-100

Ⓒ PISTON ROD 90/45-100

Ⓓ ЦИЛИНДР 90/45-100

Ⓒ TRZPIEŃ TŁOKA 90/45-100



**4015894**

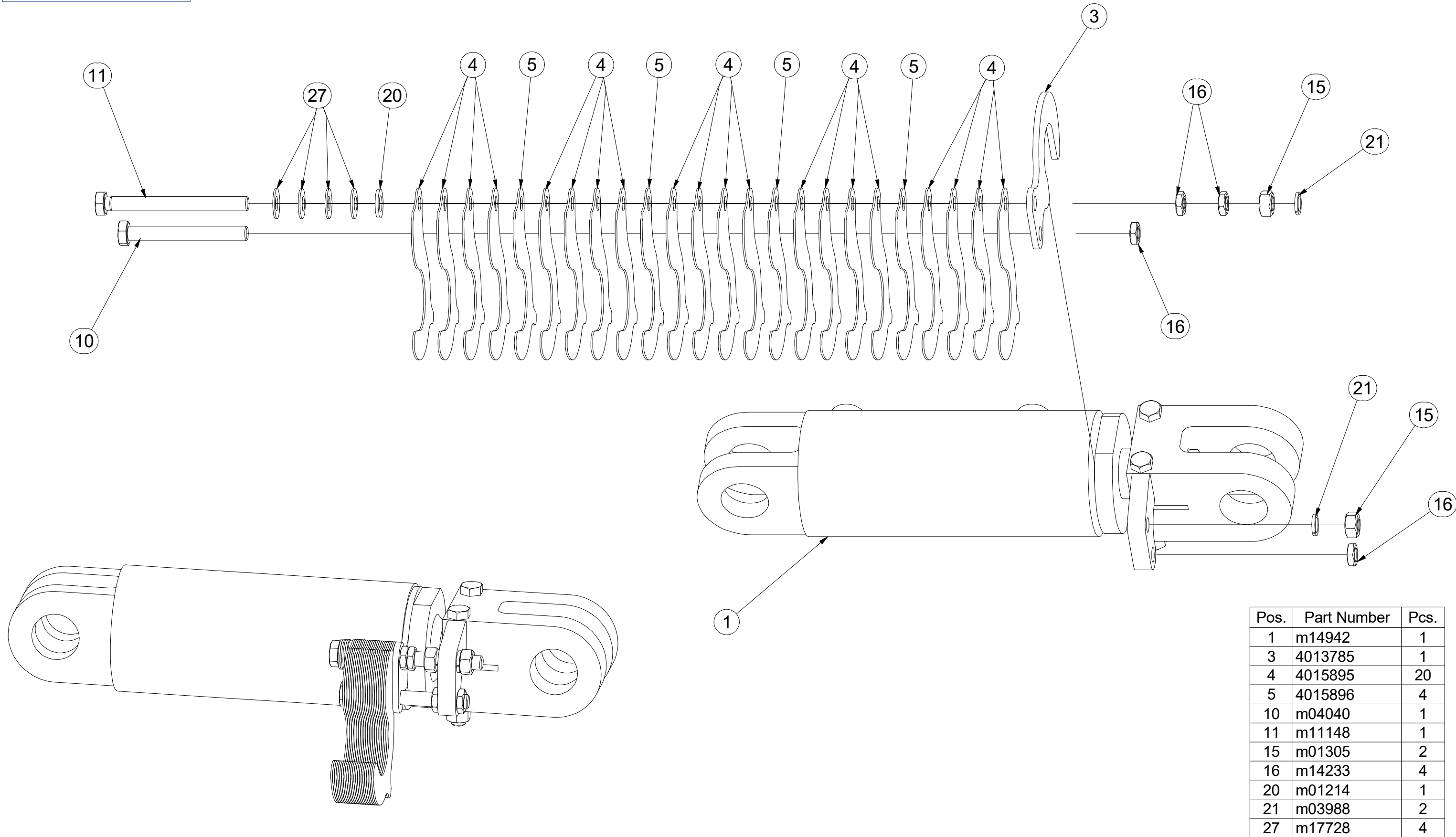

| Pos. | Part Number | Pcs. |
|------|-------------|------|
| 1    | m14942      | 1    |
| 3    | 4013785     | 1    |
| 4    | 4015895     | 20   |
| 5    | 4015896     | 4    |
| 10   | m04040      | 1    |
| 11   | m11148      | 1    |
| 15   | m01305      | 2    |
| 16   | m14233      | 4    |
| 20   | m01214      | 1    |
| 21   | m03988      | 2    |
| 27   | m17728      | 4    |

Ⓒ PÍSTNICE 110/56-100

Ⓓ KOLBENSTANGE 110/56-100

Ⓕ TIGE DE PISTON 110/56-100

Ⓖ PISTON ROD 110/56-100

Ⓔ ЦИЛИНДР 110/56-100

Ⓟ TRZPIEŃ TŁOKA 110/56-100



**VZ00011042**

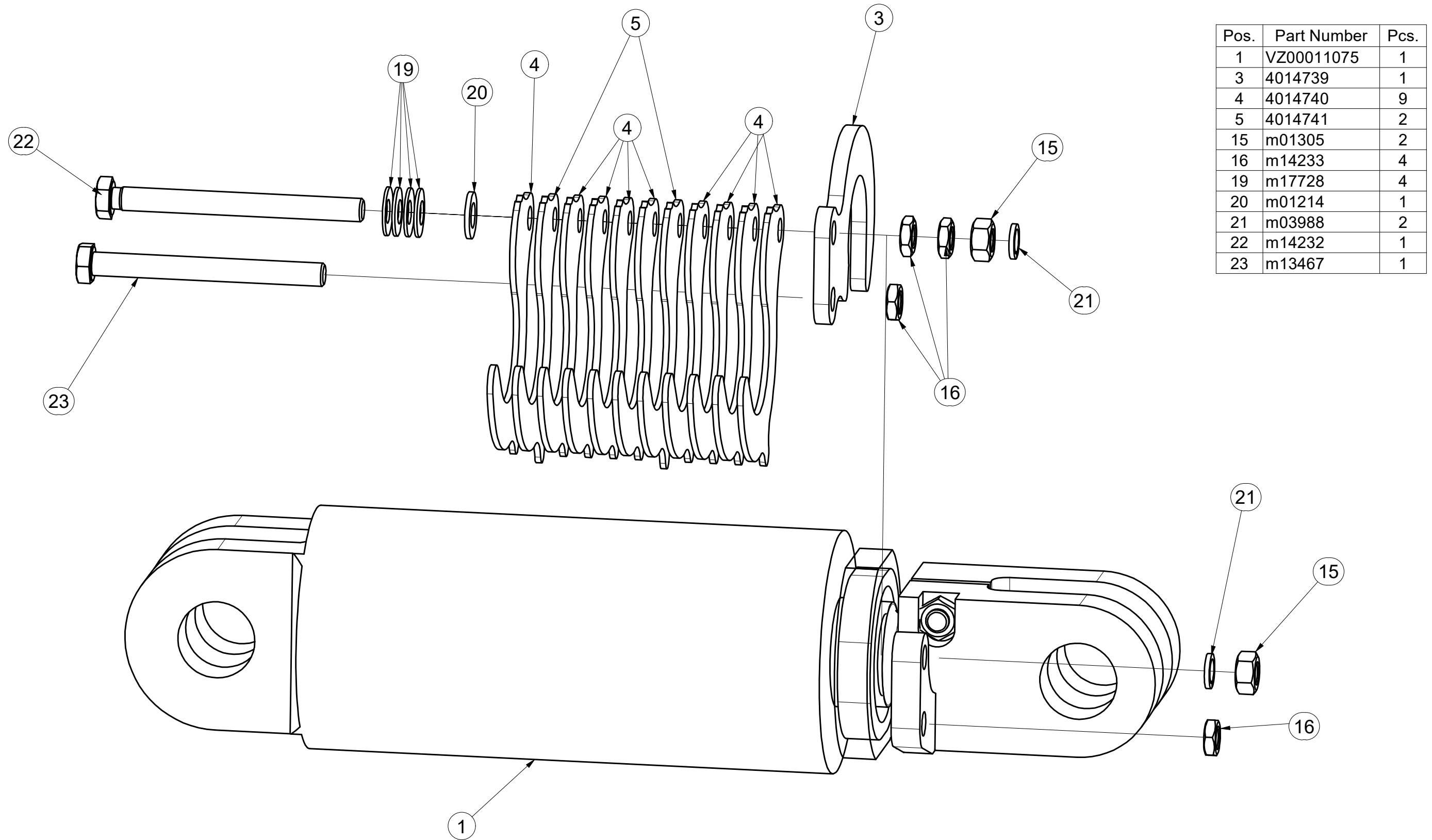

| Pos. | Part Number | Pcs. |
|------|-------------|------|
| 1    | VZ00011075  | 1    |
| 3    | 4014739     | 1    |
| 4    | 4014740     | 9    |
| 5    | 4014741     | 2    |
| 15   | m01305      | 2    |
| 16   | m14233      | 4    |
| 19   | m17728      | 4    |
| 20   | m01214      | 1    |
| 21   | m03988      | 2    |
| 22   | m14232      | 1    |
| 23   | m13467      | 1    |

Ⓒ PÍSTNICE 110/56-100

Ⓓ KOLBENSTANGE 110/56-100

Ⓕ TIGE DE PISTON 110/56-100

Ⓖ PISTON ROD 110/56-100

Ⓡ ЦИЛИНДР 110/56-100

Ⓟ TRZPIEŃ TŁOKA 110/56-100

**Farmet**

**VZ00011075**

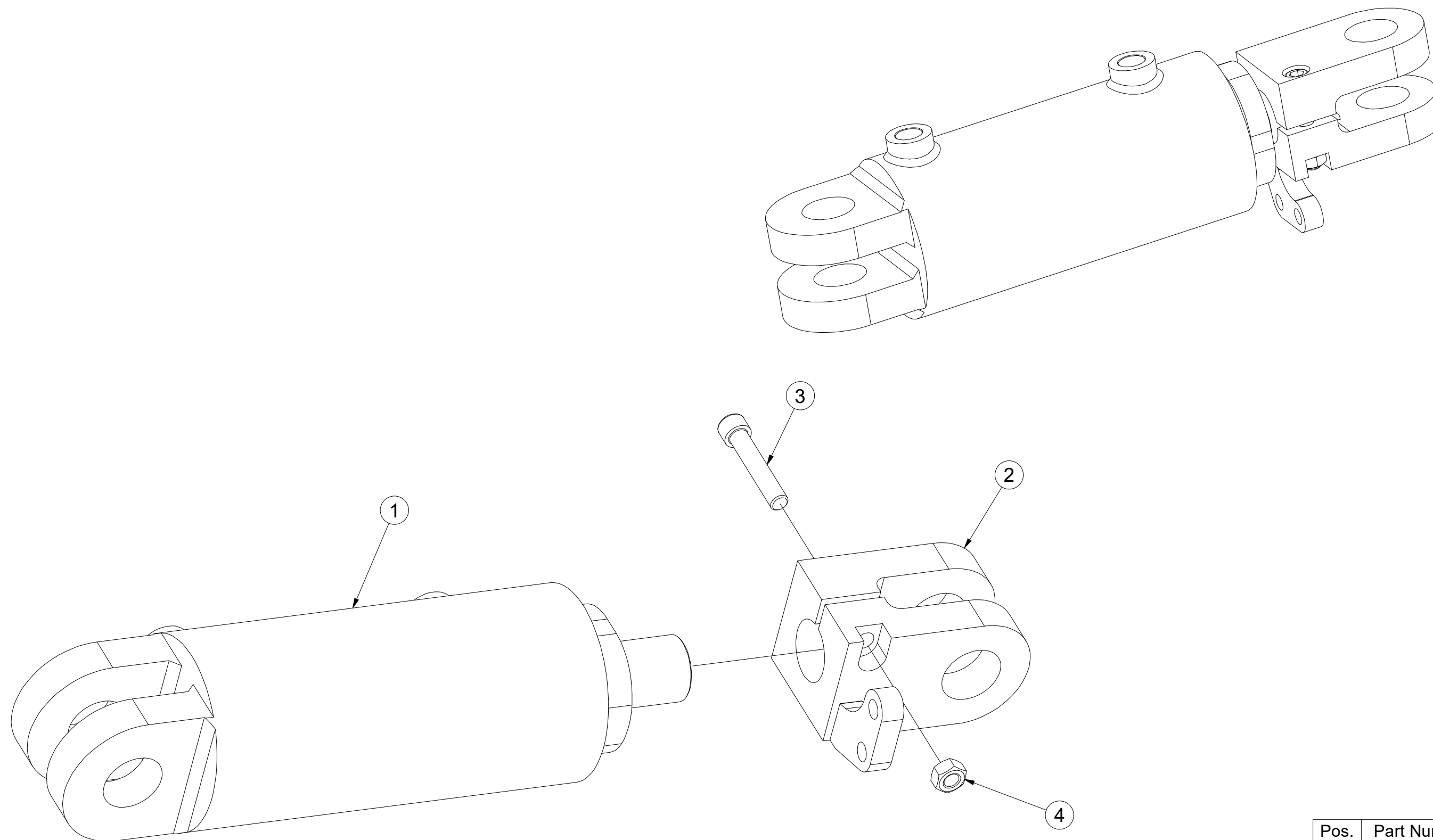

| Pos. | Part Number | Pcs. |
|------|-------------|------|
| 1    | m21020      | 1    |
| 2    | m20347      | 1    |
| 3    | m14867      | 1    |
| 4    | m10439      | 1    |

Ⓒ PÍSTNICE 110/56-100

Ⓓ KOLBENSTANGE 110/56-100

Ⓕ TIGE DE PISTON 110/56-100

Ⓖ PISTON ROD 110/56-100

Ⓡ ЦИЛИНДР 110/56-100

Ⓟ TRZPIEŃ TŁOKA 110/56-100



**VZ00011113**

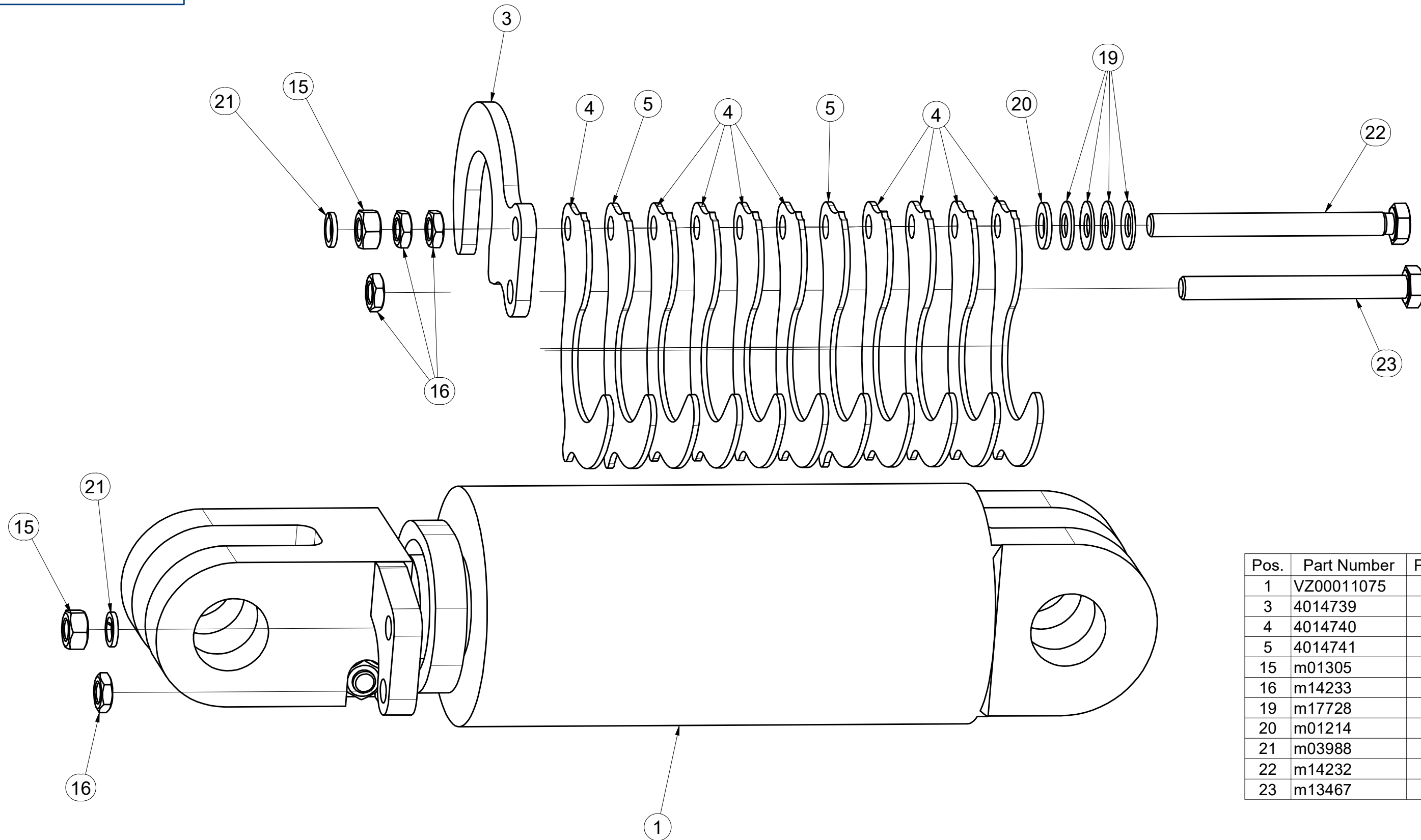

| Pos. | Part Number | Pcs. |
|------|-------------|------|
| 1    | VZ00011075  | 1    |
| 3    | 4014739     | 1    |
| 4    | 4014740     | 9    |
| 5    | 4014741     | 2    |
| 15   | m01305      | 2    |
| 16   | m14233      | 4    |
| 19   | m17728      | 4    |
| 20   | m01214      | 1    |
| 21   | m03988      | 2    |
| 22   | m14232      | 1    |
| 23   | m13467      | 1    |

CZ DRŽÁK  
 D HALTER  
 F SUPPORT

GB HOLDER  
 RU ДЕРЖАТЕЛЬ  
 PL UCHWYT



**VZ00010112**

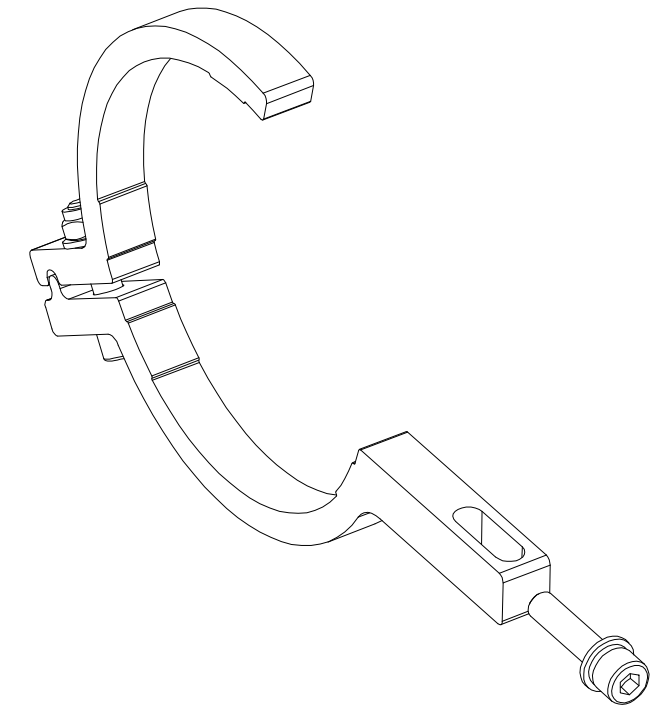
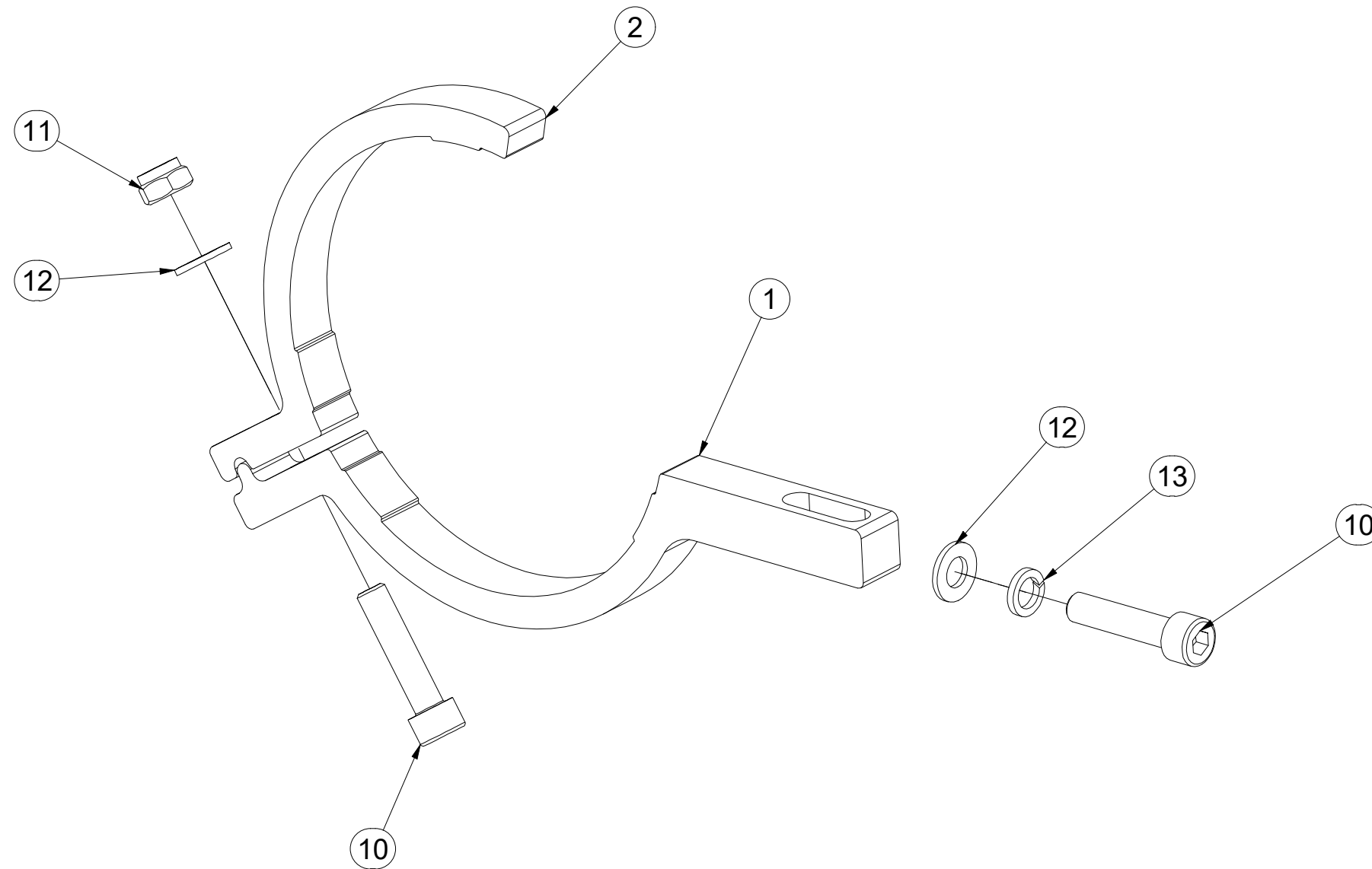

| Pos. | Part Number | Pcs. |
|------|-------------|------|
| 1    | VZ00010113  | 1    |
| 2    | VZ00010114  | 1    |
| 10   | m09464      | 2    |
| 11   | m04503      | 1    |
| 12   | m01203      | 2    |
| 13   | m01202      | 1    |

- ⒸZ DRŽÁK
- Ⓓ HALTER
- Ⓕ SUPPORT

- ⒼB HOLDER
- ⒶRU ДЕРЖАТЕЛЬ
- ⒶPL UCHWYT



**VZ00010409**

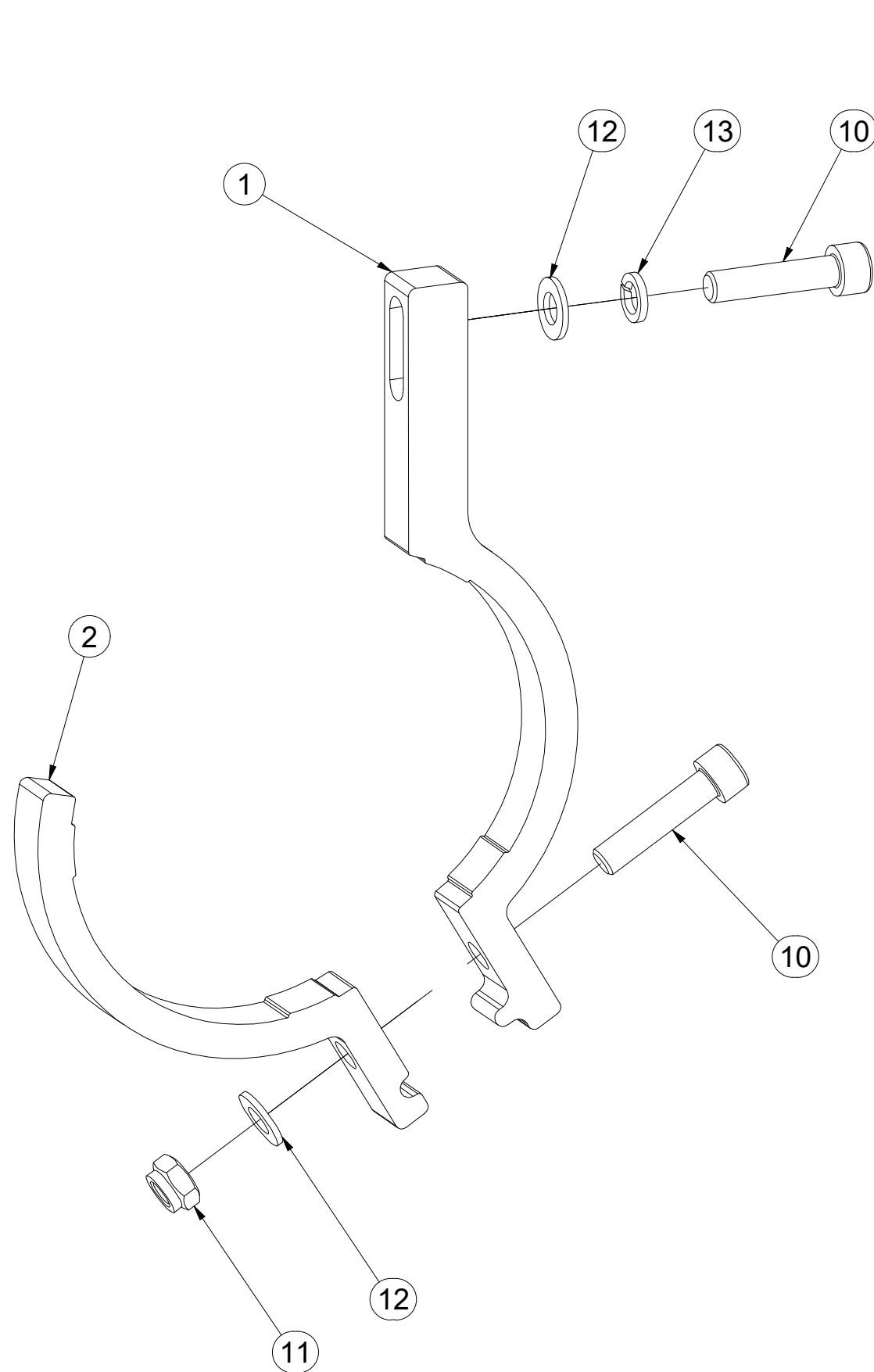

| Pos. | Part Number | Pcs. |
|------|-------------|------|
| 1    | VZ00010410  | 1    |
| 2    | VZ00010408  | 1    |
| 10   | m09464      | 2    |
| 11   | m04503      | 1    |
| 12   | m01203      | 2    |
| 13   | m01202      | 1    |

ⒸZ SOUPRAVA TĚSNIVA PÍSTNIC

Ⓓ KOLBENSTANGENDICHTUNGSMITTELSATZ

Ⓕ SET DE GARNITURE DES TIGES DE PISTON

ⒼB SEALING SET FOR PISTON RODS

ⒺU КОМПЛЕКТ ПРОКЛАДОК ЦИЛИНДРОВ

ⒻL ZESTAW USZCZELEK TRZPIENIA TŁOKA

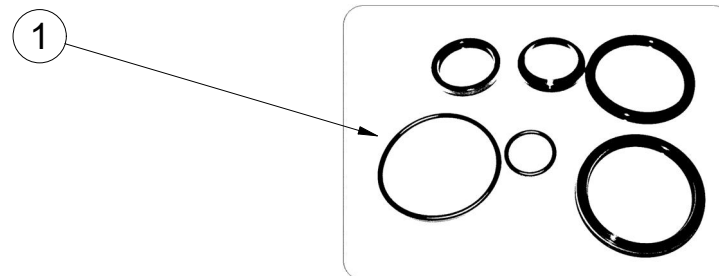
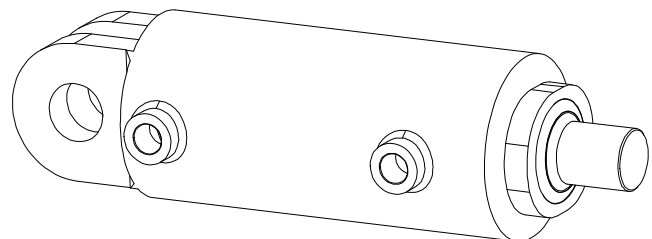

| m21020 - Ø110/Ø56-100 |             |     |
|-----------------------|-------------|-----|
| Pos                   | Part number | Pcs |
| 1                     | m15376      | 2   |

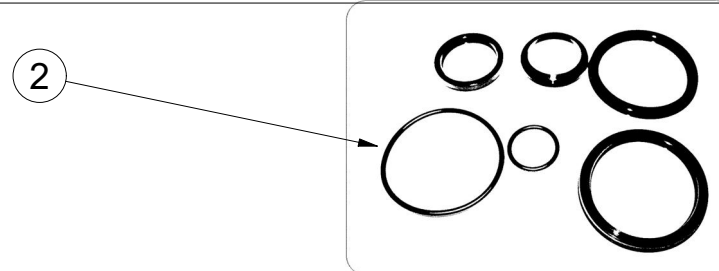
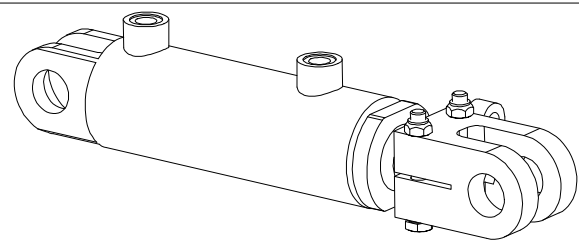

| m14940- Ø63/Ø40-95 |             |     |
|--------------------|-------------|-----|
| Pos                | Part number | Pcs |
| 2                  | m15372      | 2   |

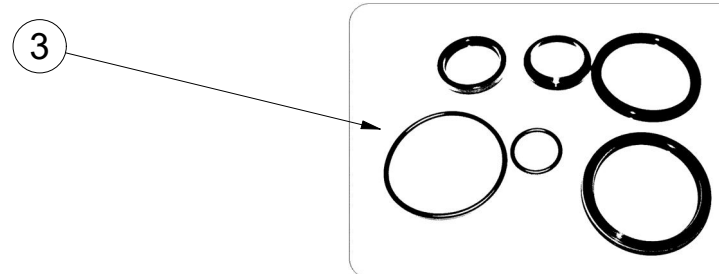
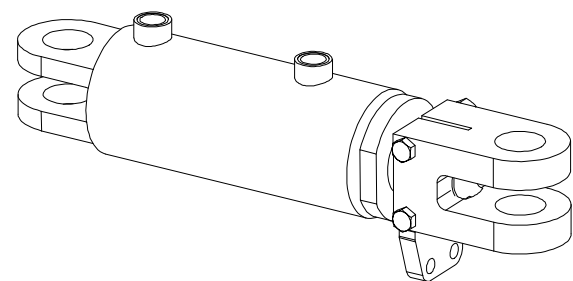

| m14942 - Ø90/Ø45-100 |             |     |
|----------------------|-------------|-----|
| Pos                  | Part number | Pcs |
| 3                    | m15374      | 2   |

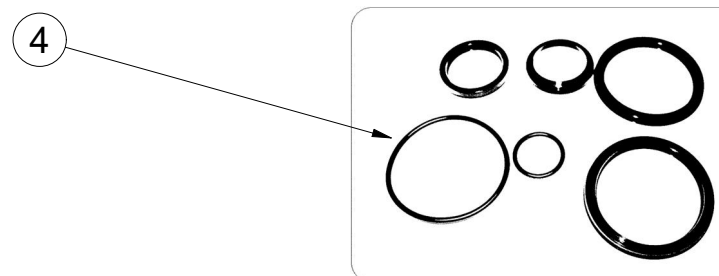
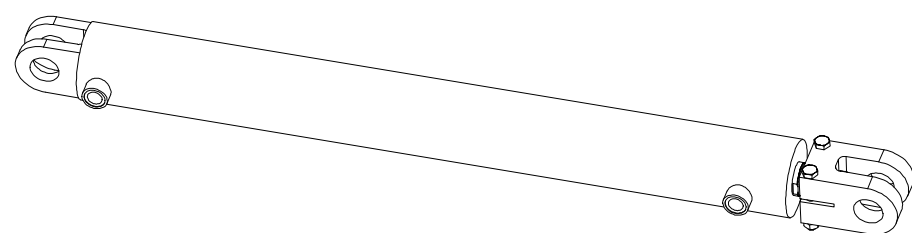

| m21525 - Ø90/Ø45-830 |             |     |
|----------------------|-------------|-----|
| Pos                  | Part number | Pcs |
| 4                    | m22828      | 2   |

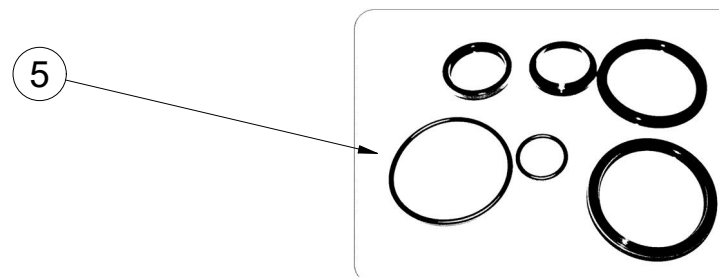
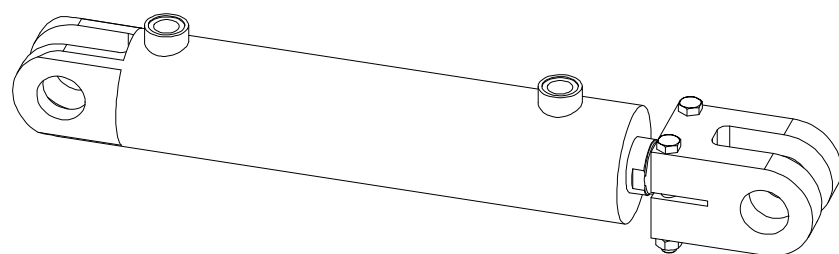

| m16836 - Ø80/Ø45-280 |             |     |
|----------------------|-------------|-----|
| Pos                  | Part number | Pcs |
| 5                    | m15373      | 1   |

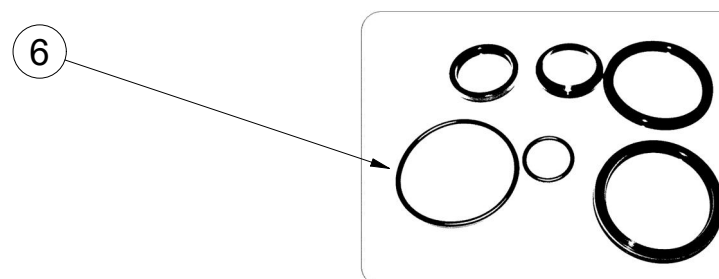
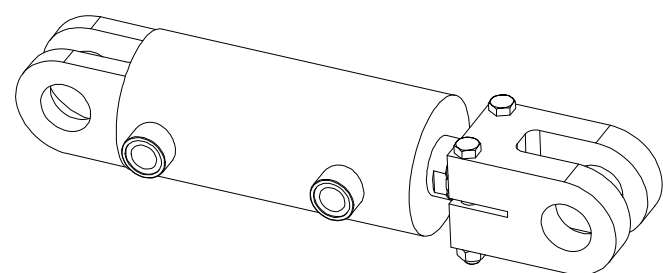

| m17172- Ø90/Ø45-100 |             |     |
|---------------------|-------------|-----|
| Pos                 | Part number | Pcs |
| 6                   | m15374      | 2   |

Ⓒ SAMOLEPKY STROJE

Ⓓ AUFKLEBER MASCHINEN

Ⓕ VOITURE MACHINES

Ⓖ STICKERS MACHINES

Ⓔ СТИКЕРЫ МАШИНЫ

Ⓗ NAKLEJKI MASZYNY



**m18691**

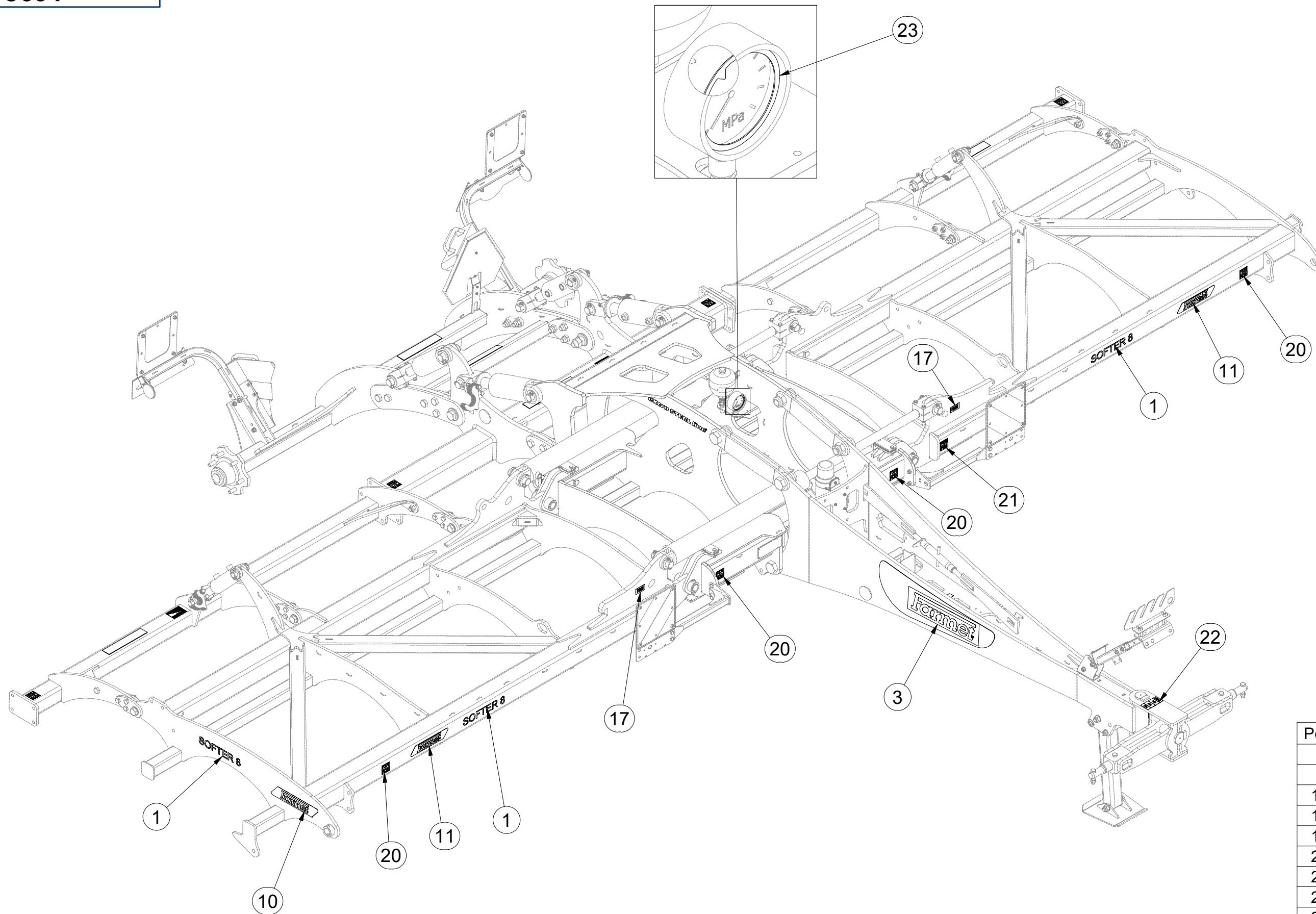

| Pos. | Part Number | Pcs. |
|------|-------------|------|
| 1    | m14964      | 7    |
| 3    | m13102      | 1    |
| 10   | m13117      | 2    |
| 11   | m13116      | 5    |
| 17   | m04368      | 4    |
| 20   | m11297      | 8    |
| 21   | m11296      | 2    |
| 22   | m11295      | 1    |
| 23   | m17300      | 1    |



CZ SAMOLEPKY STROJE  
 D AUFKLEBER MASCHINEN  
 F VOITURE MACHINES

GB STICKERS MACHINES  
 RU СТИКЕРЫ МАШИНЫ  
 PL NAKLEJKI MASZYNY



**m18691**

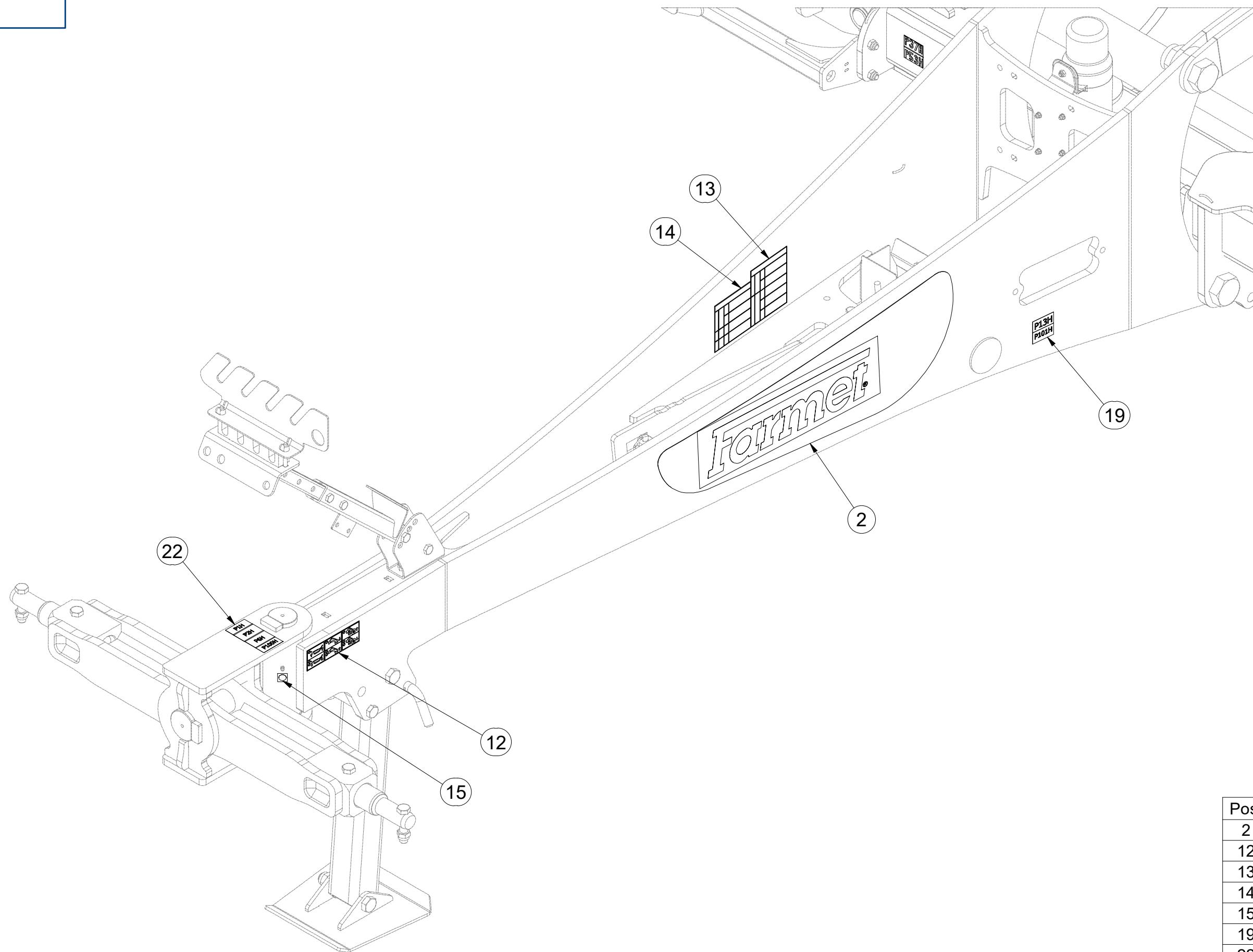

| Pos. | Part Number | Pcs. |
|------|-------------|------|
| 2    | m13101      | 1    |
| 12   | m21969      | 1    |
| 13   | m11788      | 1    |
| 14   | m11787      | 1    |
| 15   | m03320      | 1    |
| 19   | m11299      | 1    |
| 22   | m11295      | 1    |

☉ SAMOLEPKY STROJE

☉ AUFKLEBER MASCHINEN

☉ VOITURE MACHINES

☉ STICKERS MACHINES

☉ СТИКЕРЫ МАШИНЫ

☉ NAKLEJKI MASZYNY



**m18691**

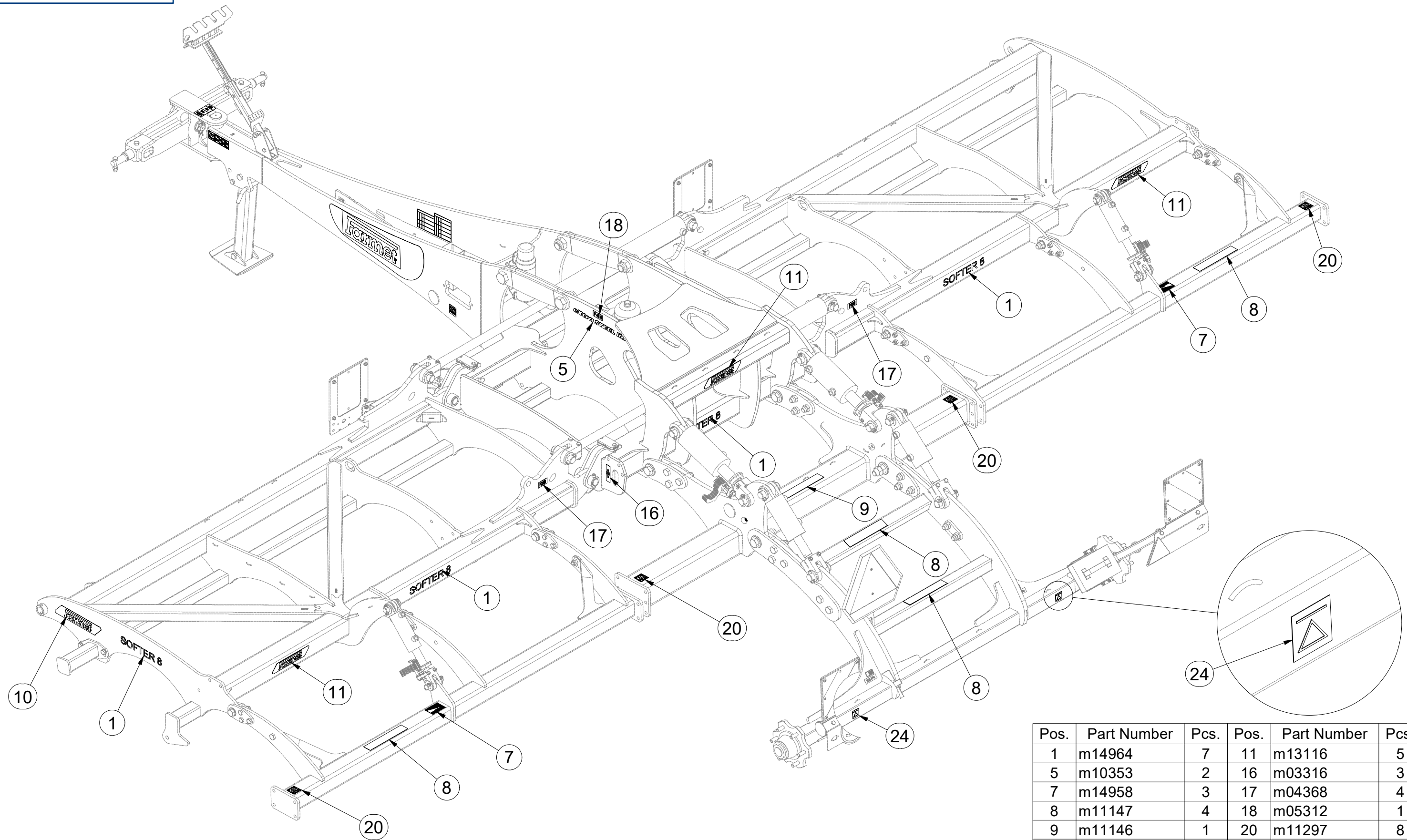

| Pos. | Part Number | Pcs. | Pos. | Part Number | Pcs. |
|------|-------------|------|------|-------------|------|
| 1    | m14964      | 7    | 11   | m13116      | 5    |
| 5    | m10353      | 2    | 16   | m03316      | 3    |
| 7    | m14958      | 3    | 17   | m04368      | 4    |
| 8    | m11147      | 4    | 18   | m05312      | 1    |
| 9    | m11146      | 1    | 20   | m11297      | 8    |
| 10   | m13117      | 2    | 24   | m03512      | 2    |

Ⓒ SAMOLEPKY STROJE

Ⓓ AUFKLEBER MASCHINEN

Ⓕ VOITURE MACHINES

Ⓖ STICKERS MACHINES

Ⓡ СТИКЕРЫ МАШИНЫ

Ⓟ NAKLEJKI MASZYNY



**4025230**

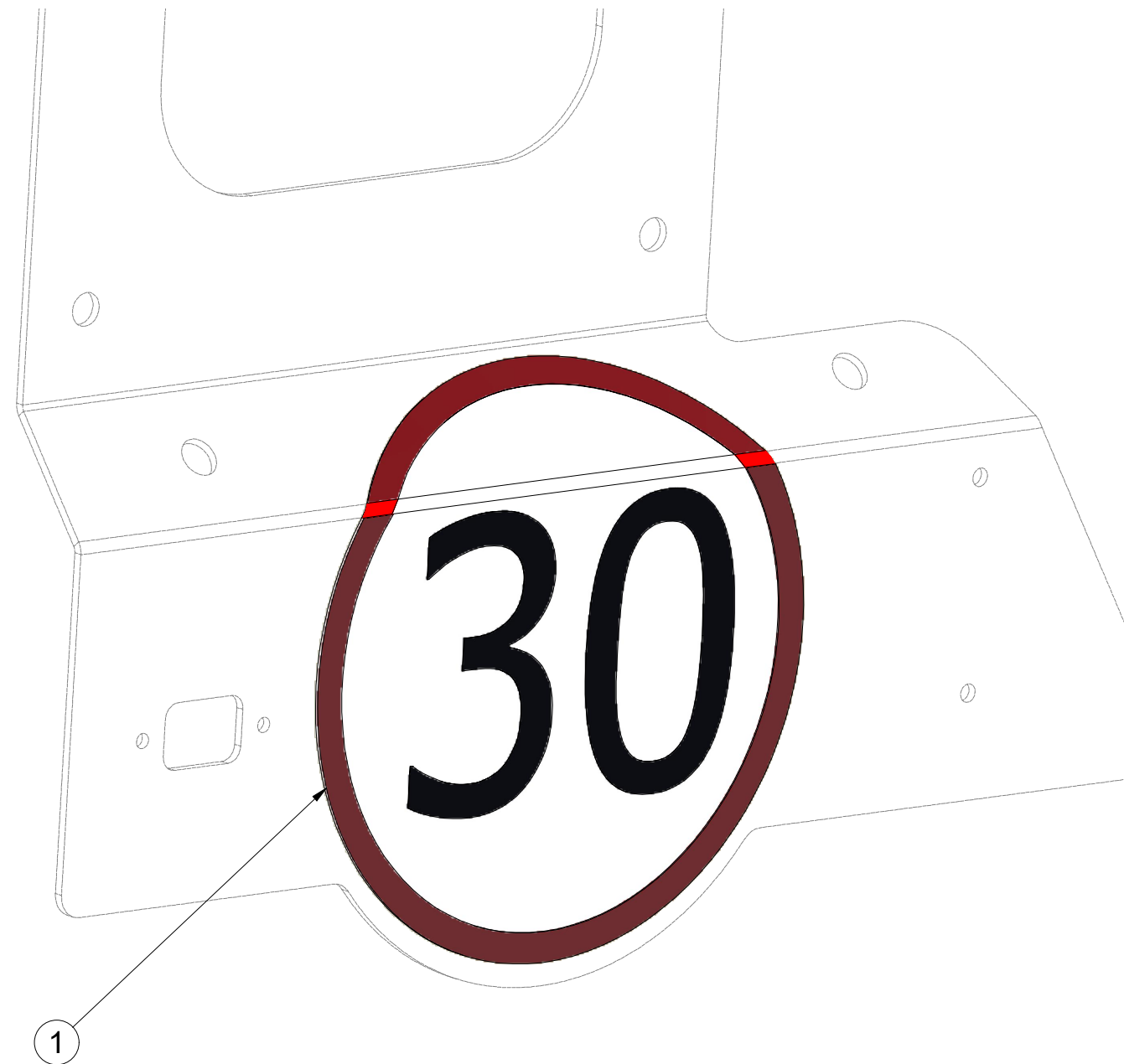

| Pos. | Part Number | Pcs. |
|------|-------------|------|
| 1    | m19161      | 1    |

Ⓒ SVĚTELNÁ SADA

Ⓓ LEUCHTENSATZ

Ⓕ KIT LUMINEUX

Ⓖ LIGHTING SET

Ⓡ ОСВЕТИТЕЛЬНЫЙ КОМПЛЕКТ

Ⓢ ZESTAW OŚWIETLENIA



**3012492**

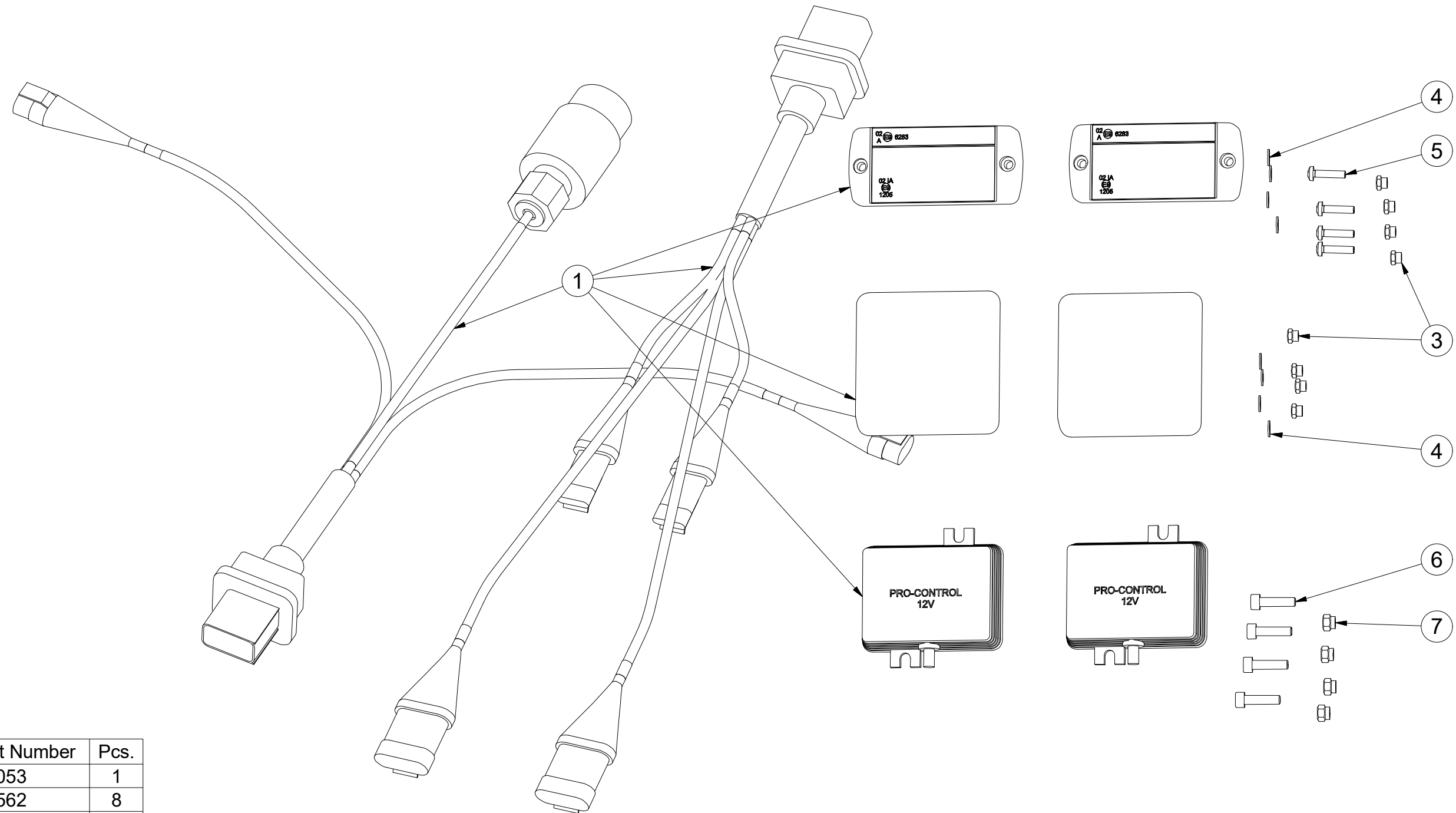

| Pos. | Part Number | Pcs. |
|------|-------------|------|
| 1    | m19053      | 1    |
| 3    | m05562      | 8    |
| 4    | m05597      | 8    |
| 5    | m15790      | 4    |
| 6    | m10591      | 4    |
| 7    | m06236      | 4    |

Ⓒ SVĚTELNÁ SADA

Ⓓ LEUCHTENSATZ

Ⓕ KIT LUMINEUX

**m19053**

Ⓖ LIGHTING SET

Ⓡ ОСВЕТИТЕЛЬНЫЙ КОМПЛЕКТ

Ⓟ ZESTAW OŚWIETLENIA

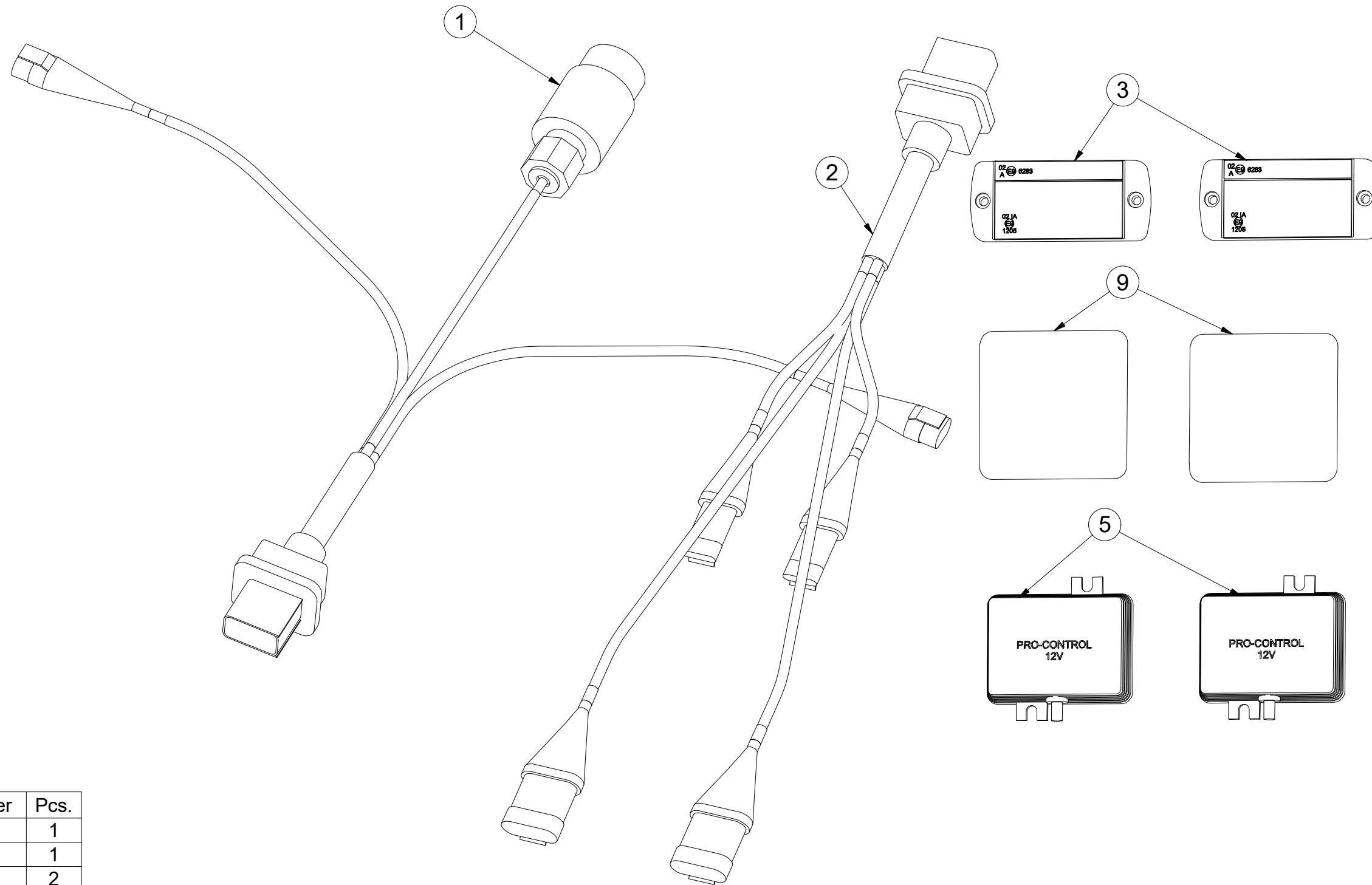

| Pos. | Part Number | Pcs. |
|------|-------------|------|
| 1    | m14779      | 1    |
| 2    | m14778      | 1    |
| 3    | m14776      | 2    |
| 5    | m14777      | 2    |
| 9    | m19044      | 2    |

- Ⓒ UTAHOVACÍ MOMENTY ŠROUBŮ  
 Ⓓ ANZUGMOMENTE VON SCHRAUBEN  
 Ⓕ COUPLES DE SERRAGE DES VIS

- Ⓒ SCREW TIGHTENING TORQUE  
 Ⓓ МОМЕНТЫ ЗАЖАТИЯ БОЛТОВ  
 Ⓕ MOMENTY DOKRĘCANIA ŚRUB



| P   |      | 5.8  | 8.8  | 10.9  | 12.9  | Z        |           |
|-----|------|------|------|-------|-------|----------|-----------|
| D   | R    | Mu   | Mu   | Mu    | Mu    | DIN 7991 | ISO 10642 |
| mm  | mm   | Nm   | Nm   | Nm    | Nm    | Nm       | Nm        |
| M6  | 1    | 6    | 9    | 13    | 15    | 7,2      | 7,9       |
| M8  | 1,25 | 14   | 22   | 32    | 38    | 17       | 19        |
| M10 | 1,5  | 29   | 44   | 64    | 75    | 35       | 38        |
| M12 | 1,75 | 49   | 76   | 111   | 130   | 58       | 65        |
| M14 | 2    | 79   | 120  | 176   | 206   | 93       | 100       |
| M16 | 2    | 123  | 188  | 276   | 323   | 144      | 158       |
| M18 | 2,5  | 169  | 257  | 378   | 443   | -        | 220       |
| M20 | 2,5  | 239  | 365  | 536   | 628   | -        | 310       |
| M22 | 2,5  | 329  | 529  | 738   | 864   | -        | 420       |
| M24 | 3    | 413  | 629  | 924   | 1082  | -        | 530       |
| M27 | 3    | 613  | 934  | 1372  | 1606  | -        | -         |
| M30 | 3,5  | 832  | 1267 | 1862  | 2179  | -        | -         |
| M33 | 3,5  | 1130 | 1723 | 2530  | 2961  | -        | -         |
| M36 | 4    | 1451 | 2210 | 3246  | 3799  | -        | -         |
| M39 | 4    | 1885 | 2872 | 4217  | 4936  | -        | -         |
| M42 | 4,5  | 2322 | 3538 | 5196  | 6080  | -        | -         |
| M45 | 4,5  | 2909 | 4433 | 6511  | 7619  | -        | -         |
| M48 | 5    | 3513 | 535  | 7862  | 9200  | -        | -         |
| M52 | 5    | 4524 | 6895 | 10123 | 11849 | -        | -         |
| M56 | 5,5  | 5636 | 8589 | 12614 | 14761 | -        | -         |

- Mu - Ⓒ UTAHOVACÍ MOMENT  
 Ⓓ ANZUGMOMENTE  
 Ⓕ COUPLE DE SERRAGE  
 Ⓒ TIGHTENING TORQUE  
 Ⓓ МОМЕНТ ЗАЖАТИЯ  
 Ⓕ MOMENT DOKRĘCANIA
- D - Ⓒ JMENOVITÝ PRŮMĚR  
 Ⓓ NENNDURCHMESSER  
 Ⓕ DIAMETRE NOMINAL  
 Ⓒ NOMINAL DIAMETER  
 Ⓓ НОМИНАЛЬНЫЙ ДИАМЕТР  
 Ⓕ ŚREDNICA NOMINALNA
- R - Ⓒ ROZTEČ ZÁVITU - STOUPÁNÍ  
 Ⓓ GEWINDESTEIGUNG  
 Ⓕ PAS DE FILET - PAS  
 Ⓒ SCREW PITCH – LEAD  
 Ⓓ ШАГ РЕЗЬБЫ  
 Ⓕ ROZSTAW GWINTU - SKOKI
- P - Ⓒ PEVNOST  
 Ⓓ FESTIGKEIT  
 Ⓕ RÉSISTANCE  
 Ⓒ STRENGTH  
 Ⓓ ПРОЧНОСТЬ  
 Ⓕ WYTRZYMA OŚĆ
- Z - Ⓒ ZÁPUSTNÉ ŠROUBY  
 Ⓓ SENKKOPFSCHRAUBEN  
 Ⓕ VIS A TETE FRAISEE  
 Ⓒ COUNTERSUNK SCREWS  
 Ⓓ БОЛТЫ С УТОПЛЕННОЙ ГОЛОВКОЙ  
 Ⓕ ŚRUBY Z ŁBEM STOŻKOWYM PŁASKIM

- Ⓒ Hodnoty momentů jsou poníženy o -10% oproti tabulkovým hodnotám. Šroubové spoje utahujte dle vyznačeného utahovacího momentu v dokumentaci. Pokud není utahovací moment v dokumentaci vyznačen, utahujte dle obecné tabulky. Pokud je v dokumentaci definován spoj šroubu a matice o různých pevnostech, vždy utahujte na moment komponenty nižší.
- Ⓓ Die Werte der Anzugsmomente sind um 10 % gegenüber den Tabellenwerten verringert. Ziehen Sie die Schraubverbindungen gemäß dem in der Dokumentation festgeschriebenen Anzugsmoment an. Sofern das Anzugsmoment nicht in der Dokumentation aufgeführt ist, ziehen Sie sie gemäß der allgemeinen Tabelle an. Wenn in der Dokumentation eine Verbindung von Schraube und Mutter mit verschiedene Festigkeiten definiert ist, wird immer mit dem Moment des Bauteils mit der geringeren Festigkeit angezogen.
- Ⓕ Les valeurs des couples de serrage sont baissées de 10% par rapport aux valeurs de tableau. Serrez les raccords à vis selon le couple de serrage indiqué dans les documents. Si le couple de serrage n'est pas indiqué dans les documents, serrez selon le tableau général. Si les documents définissent un assemblage par boulon de diverses résistances, serrez toujours au moment de la composante avec résistance inférieure.
- Ⓒ The torque values are reduced by 10% compared to the table values. Tighten the screw joints according to the tightening torque stated in the documentation. If the tightening torque is not stated in the documentation, tighten according to the general table. If there is a joint with a screw and a nut at different strengths in the documentation, always tighten to the torque of the component with lower strength.
- Ⓓ Значения моментов затяжки уменьшены на 10% по сравнению с данными в таблице. Резьбовые соединения зажимайте с установленным в документации моментом зажатия. Если в документации не указан момент зажатия, то зажимайте по действующей в общем таблице. Если в документации установлено соединение из болта и гайки различной прочности, всегда зажимайте с моментом для компонента с меньшей прочностью.
- Ⓕ Wartości momentów dokręcania są obniżone o 10% w stosunku do wartości z tabeli. Połączenia śrubowe należy dokręcać zgodnie z momentem obrotowym w dokumentacji. Jeśli w dokumentacji nie ma podanego momentu obrotowego, należy dokręcać zgodnie z ogólną tabelą. Jeśli w dokumentacji zdefiniowane jest połączenie ze śrubą nakrętką różnych wytrzymałościach, zawsze należy dokręcać zachowując moment dokręcania komponentu z niższą wytrzymałością.

- Ⓒ UTAHOVACÍ MOMENTY ŠROUBŮ  
 Ⓓ ANZUGMOMENTE VON SCHRAUBEN  
 Ⓕ COUPLES DE SERRAGE DES VIS

- Ⓒ SCREW TIGHTENING TORQUE  
 Ⓓ МОМЕНТЫ ЗАЖАТИЯ БОЛТОВ  
 Ⓕ MOMENTY DOKRĘCANIA ŚRUB



- Ⓒ **OBECNÝ PŘEDPIS UTAHOVÁNÍ ZAJIŠTĚNÍ ČEPOVÝCH SPOJŮ:**  
 Ⓓ **ALLGEMEINE VORSCHRIFT FÜR DAS ANZIEHEN VON BOLZENVERBINDUNGEN:**  
 Ⓕ **CONSIGNE GENERALE POUR LE SERRAGE DES ARTICULATIONS CYLINDRIQUES:**  
 Ⓒ **GENERAL INSTRUCTION FOR TIGHTENING THE SECURING OF PIN JOINTS:**  
 Ⓓ **ОБЩЕЕ ОПИСАНИЕ ЗАЖАТИЯ ПРЕДОХРАНЕНИЯ СОЕДИНЕНИЙ ПАЛЬЦАМИ:**  
 Ⓕ **OGÓLNE ZASADY DOKRĘCANIA ZABEZPIECZENIA POŁĄCZEŃ CZOPEM:**



**X**

M8, M10, M12

M14

**M**

09-15Nm

15-25Nm

- X - Ⓒ ROZMĚR ŠROUBU  
 Ⓓ SCHRAUBENGRÖSSE  
 Ⓕ DIMENSIONS DE LA VIS

- Ⓒ BOLT DIMENSION  
 Ⓓ РАЗМЕР БОЛТА  
 Ⓕ ROZMIAR ŚRUBY

- M - Ⓒ ORIENTAČNÍ MOMENT  
 Ⓓ ANZUGSMOMENT  
 Ⓕ COUPLE D'ORIENTATION

- Ⓒ ORIENTATION TORQUE  
 Ⓓ ОРИЕНТАЦИОННЫЙ МОМЕНТ  
 Ⓕ ORIENTACYJNY MOMENT

- Ⓒ Tyto spoje není nutné ověřovat kontrolou momentovým klíčem = stačí vizuálně kontrolovat sešroubování.  
 Ⓓ Diese Verbindungen müssen nicht mit einem Drehmomentschlüssel überprüft werden = es genügt, die Verschraubung visuell zu kontrollieren.  
 Ⓕ Il n'est pas nécessaire de contrôler le serrage à l'aide d'une clé dynamométrique = un contrôle visuel de l'assemblage suffit.  
 Ⓒ These joints do not have to be verified by checking with a torque wrench = visual inspection of bolting is sufficient.  
 Ⓓ Эти соединения не нужно контролировать динамометрическим ключом = достаточно визуально проверять прикручивание.  
 Ⓕ Nie trzeba sprawdzać tych połączeń kluczem dynamometrycznym = wystarczy wizualnie skontrolować dokręcenie.