

The effective technology and complex services

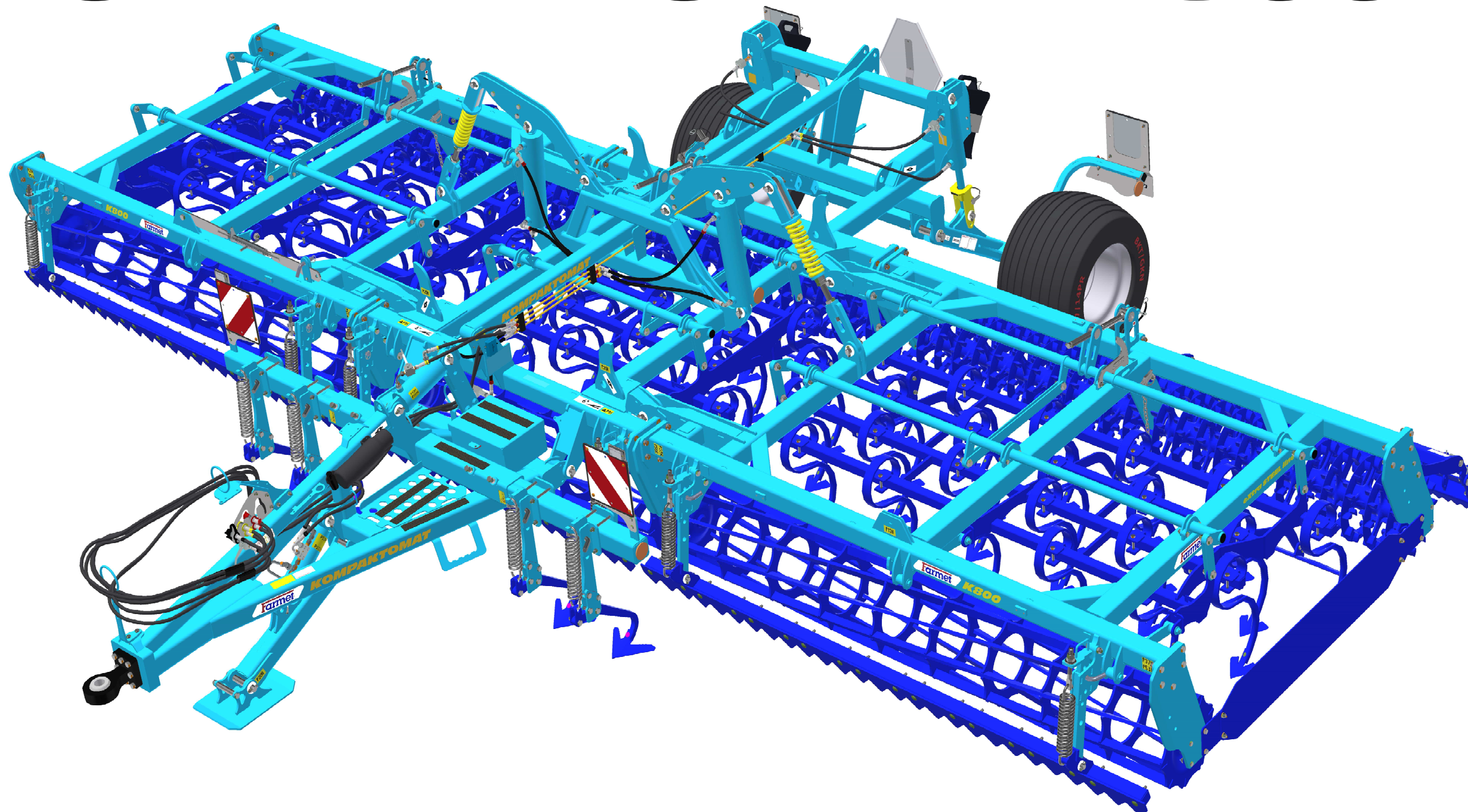

ⒸZ KATALOG NÁHRADNÍCH DÍLŮ ⒸB CATALOGUE OF SPARE PARTS ⒸD ERSATZTEILLISTE  
ⒸRU КАТАЛОГ ЗАПАСНЫХ ЧАСТЕЙ ⒸF CATALOGUE DES PIÈCES DE RECHANGE ⒸPL KATALOG CZĘŚCI ZAMIENNYCH

# КОМПАКТОМАТ K800PSL



ⒸZ Platnost pro vrcholové | výrobní číslo stroje ⒸB Validity for the top | serial number of the machine  
ⒸD Gültigkeit für die Haupt- | Herstellungsnummer der Maschine ⒸRU Действительно для главного | заводского номера машины  
ⒸF Validité du numéro de référence | de série de la machine ⒸPL Obowiązuje dla numeru głównego | seryjnego maszyny

9330106 | 2024/0102

Farmet a. s.  
Jiřinková 276  
552 03 Česká Skalice, CZ

phone: +420 491 450 111  
GSM: +420 774 715 738

Id. No.: 46504931  
Tax Id. No.: CZ46504931

web: [www.farmet.eu](http://www.farmet.eu)  
e-mail: [dzt@farmet.cz](mailto:dzt@farmet.cz)

ⒸZ NAVIGACE STROJE

Ⓓ NAVIGATION DER MASCHINE

Ⓕ NAVIGATION DE LA MACHINE

ⒸB NAVIGATION OF THE MACHINE

ⒸU НАВИГАЦИЯ МАШИНЫ

ⒸL NAWIGACJA MASZYNY

**Farmet**

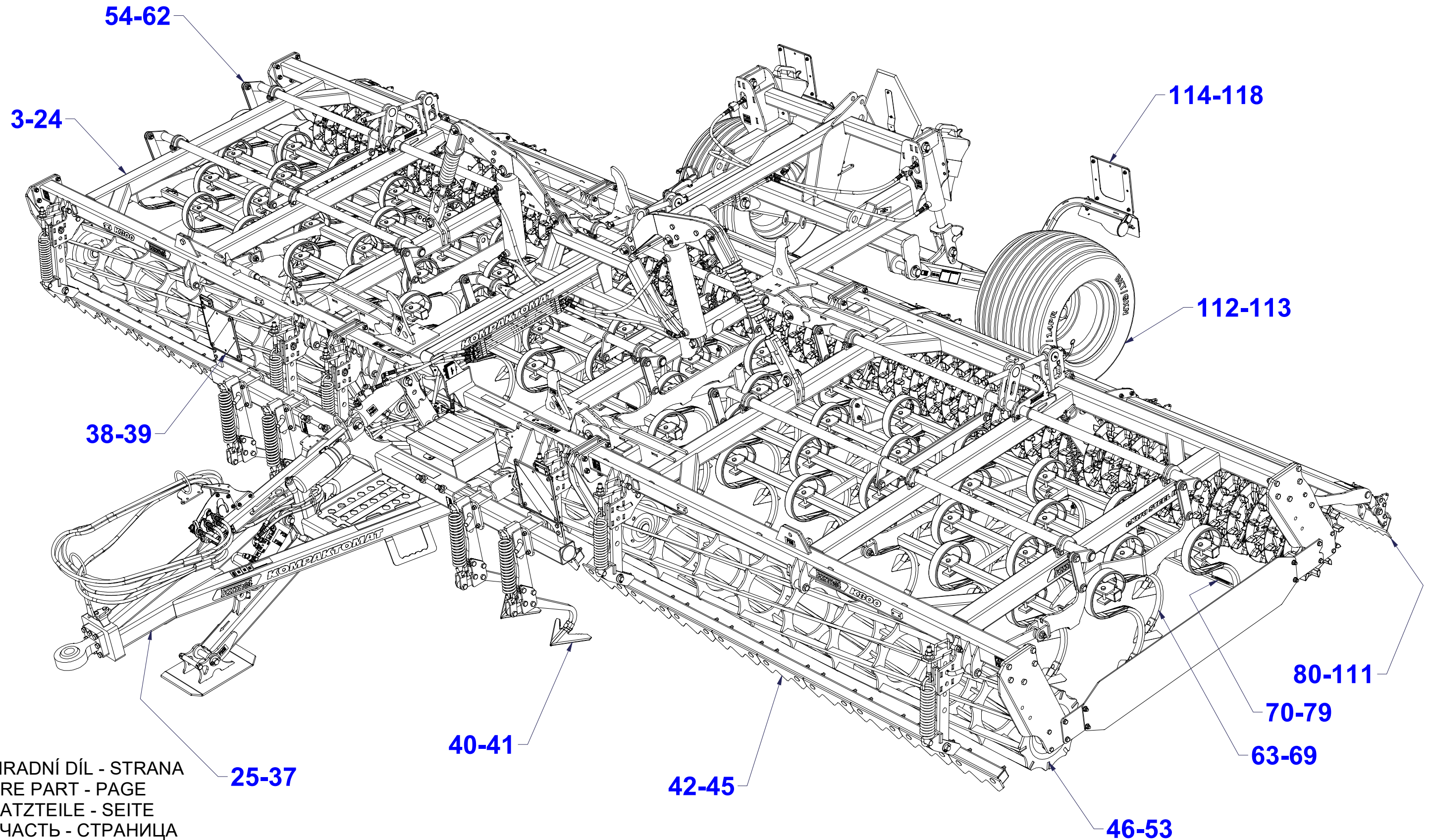

ⒸZ NÁHRADNÍ DÍL - STRANA

ⒸB SPARE PART - PAGE

Ⓓ ERSATZTEILE - SEITE

ⒸU ЗАПЧАСТЬ - СТРАНИЦА

Ⓕ PIÈCE DE RECHANGE - PAGE

ⒸL CZĘŚCI ZAMIENNE - STRONA

☉ POLOTOVAR STROJE

☉ MASCHINEN-HALBFABRIKAT

☉ MACHINE - SEMI-PRODUIT

☉ SEMIFINISHED MACHINE

☉ ПОЛУФАБРИКАТ МАШИНЫ

☉ PÓŁFABRYKAT MASZYN



VZ00042795

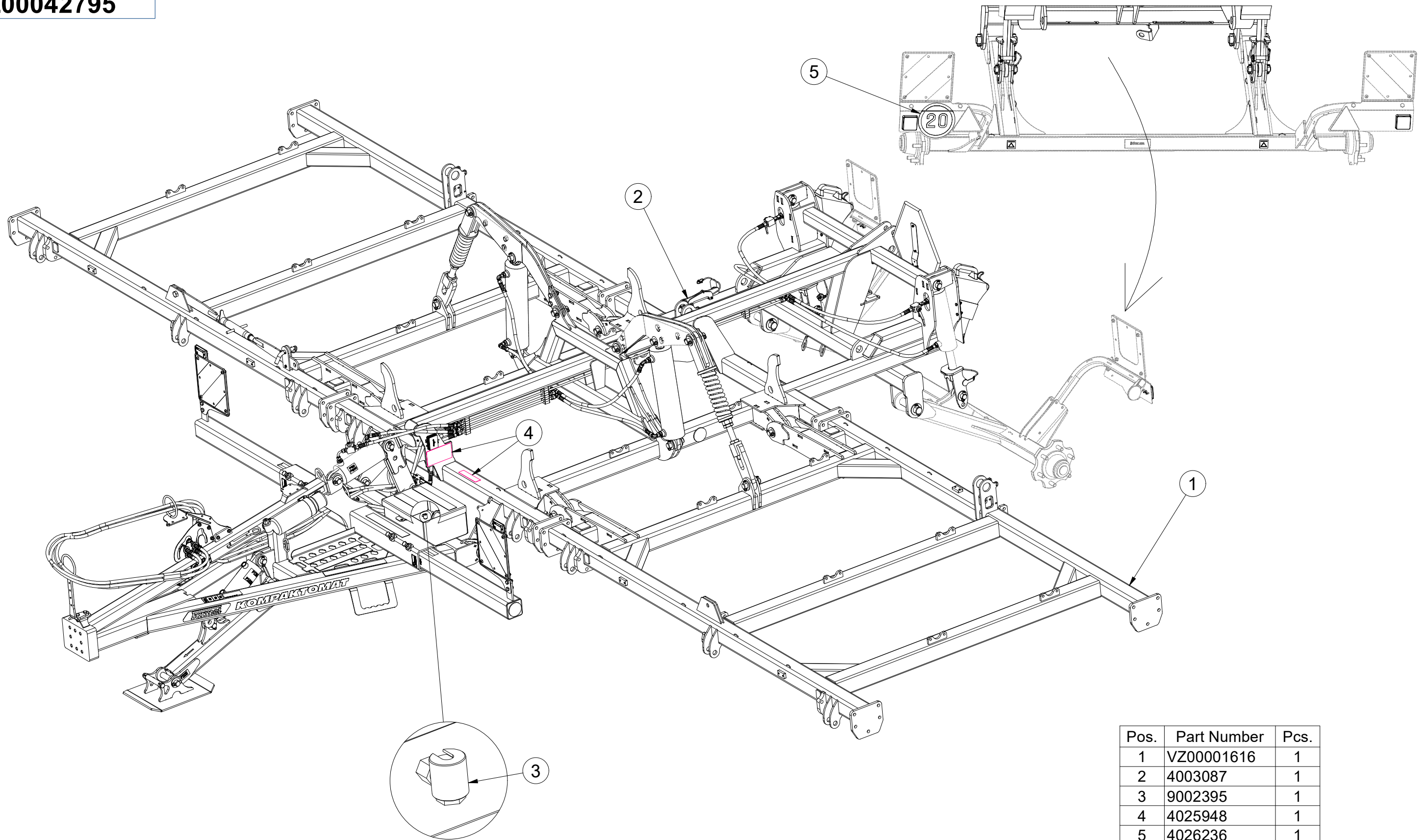

Pos.	Part Number	Pcs.
1	VZ00001616	1
2	4003087	1
3	9002395	1
4	4025948	1
5	4026236	1

Ⓒ NASAZOVACÍ KLIKA

Ⓓ MONTAGEGRIF

Ⓕ POIGNÉE DE MONTAGE

**4003087**

Ⓖ MOUNTING HANDLE

Ⓡ МОНТАЖНАЯ РУЧКА

Ⓢ UCHWYT MONTAŻOWY

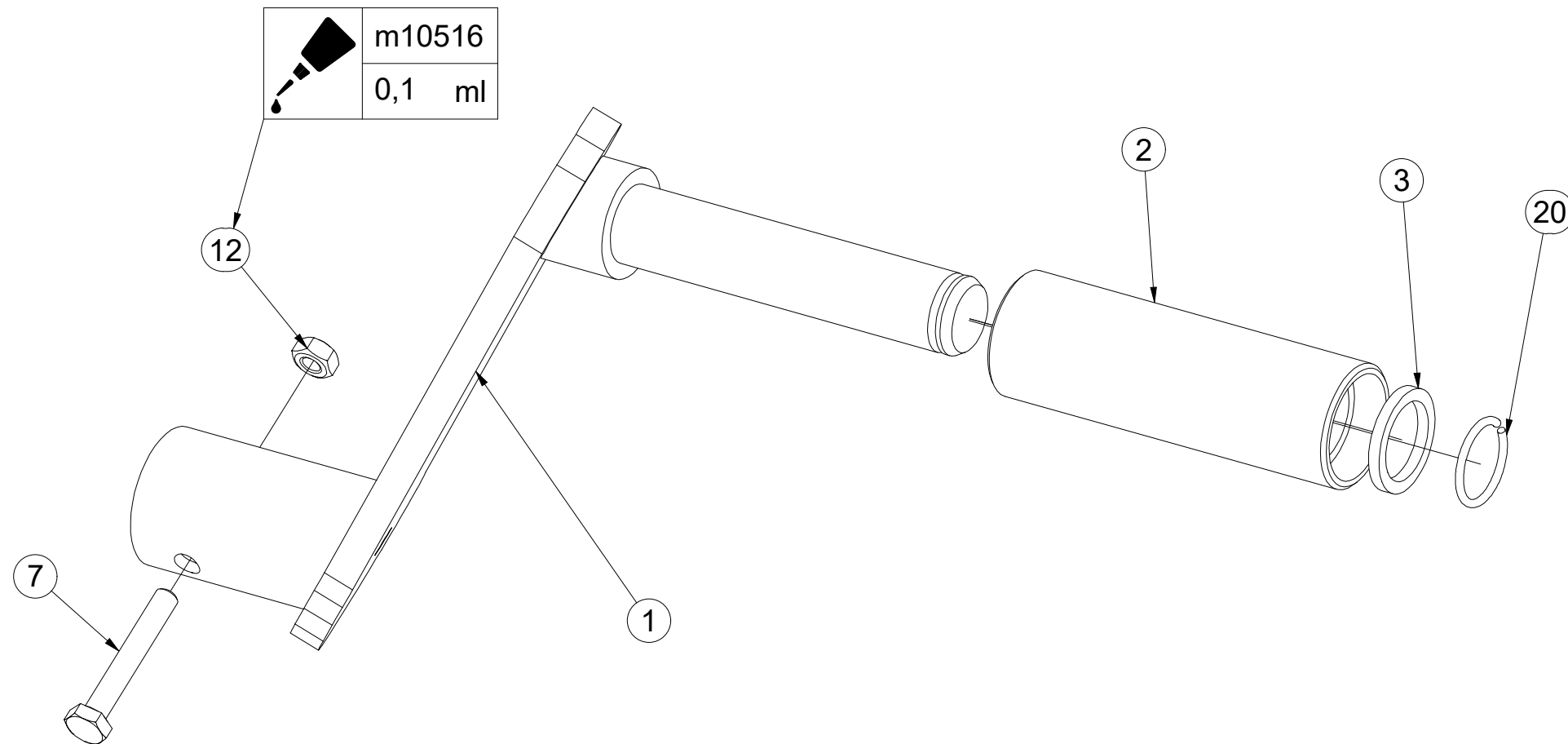
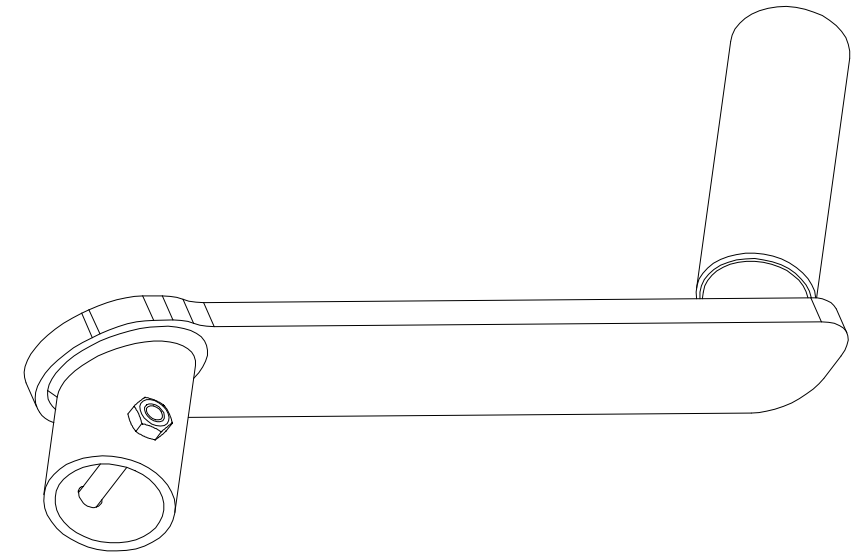

Pos.	Part Number	Pcs.
1	4003092	1
2	4001533	1
3	4004828	1
7	m04641	1
12	m01295	1
20	m06561	1
25	m10516	0,1

Ⓒ POLOTOVAR STROJE

Ⓓ MASCHINEN-HALBFABRIKAT

Ⓕ MACHINE - SEMI-PRODUIT

Ⓖ SEMIFINISHED MACHINE

Ⓡ ПОЛУФАБРИКАТ МАШИНЫ

Ⓟ PÓLFABRYKAT MASZYN



**VZ0001616**

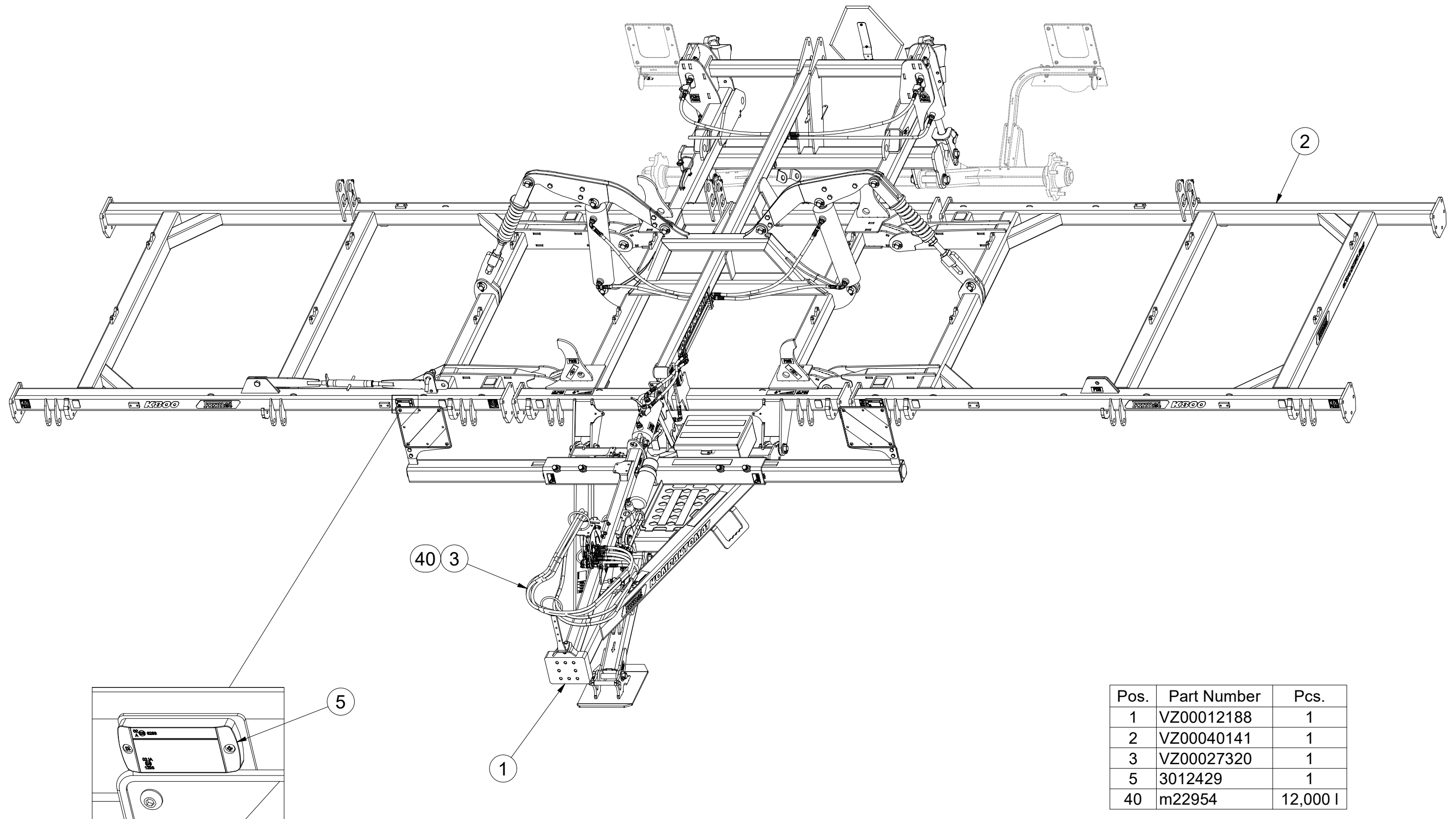

Pos.	Part Number	Pcs.
1	VZ00012188	1
2	VZ00040141	1
3	VZ00027320	1
5	3012429	1
40	m22954	12,000 I

Ⓒ POLOTOVAR STROJE

Ⓓ MASCHINEN-HALBFABRIKAT

Ⓕ MACHINE - SEMI-PRODUIT

Ⓖ SEMIFINISHED MACHINE

Ⓡ ПОЛУФАБРИКАТ МАШИНЫ

Ⓢ РÓЉФАБРЫКАТ МАСЗЫНЫ



**VZ00001616**

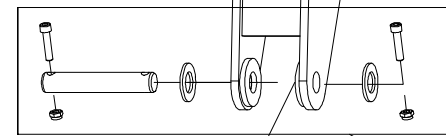
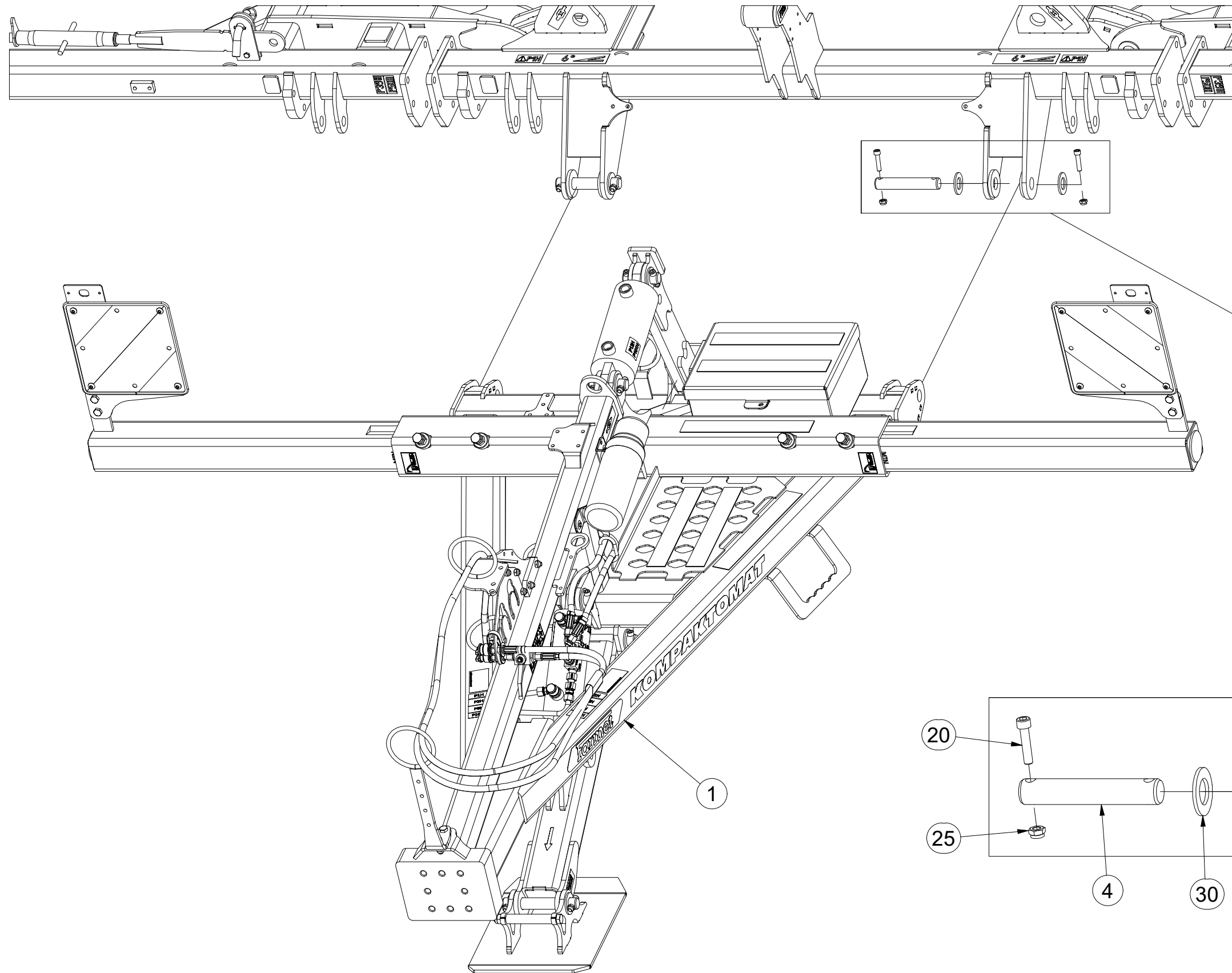

Pos.	Part Number	Pcs.
1	VZ00012188	1
4	4011050	2
20	m14143	4
25	m03775	4
30	m14029	4

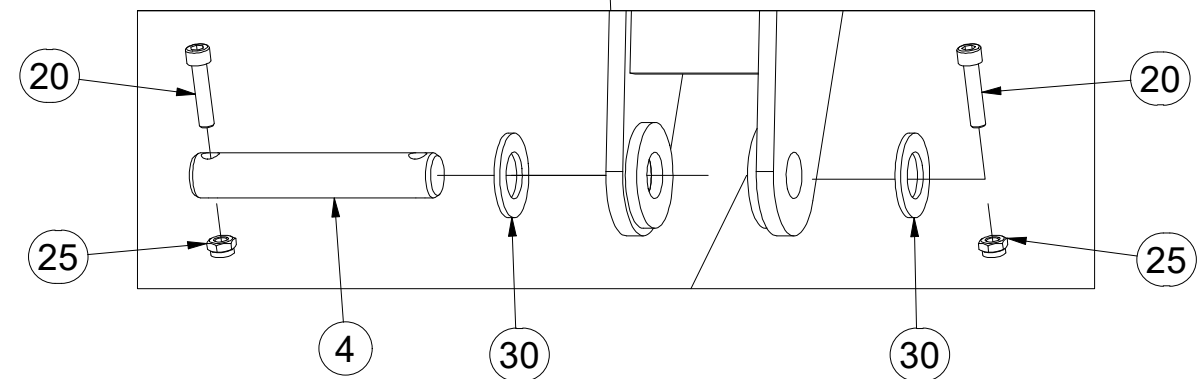

Ⓒ POLOTOVAR STROJE

Ⓓ MASCHINEN-HALBFABRIKAT

Ⓕ MACHINE - SEMI-PRODUIT

Ⓖ SEMIFINISHED MACHINE

Ⓡ ПОЛУФАБРИКАТ МАШИНЫ

Ⓟ PÓŁFABRYKAT MASZYNY



**VZ00040141**

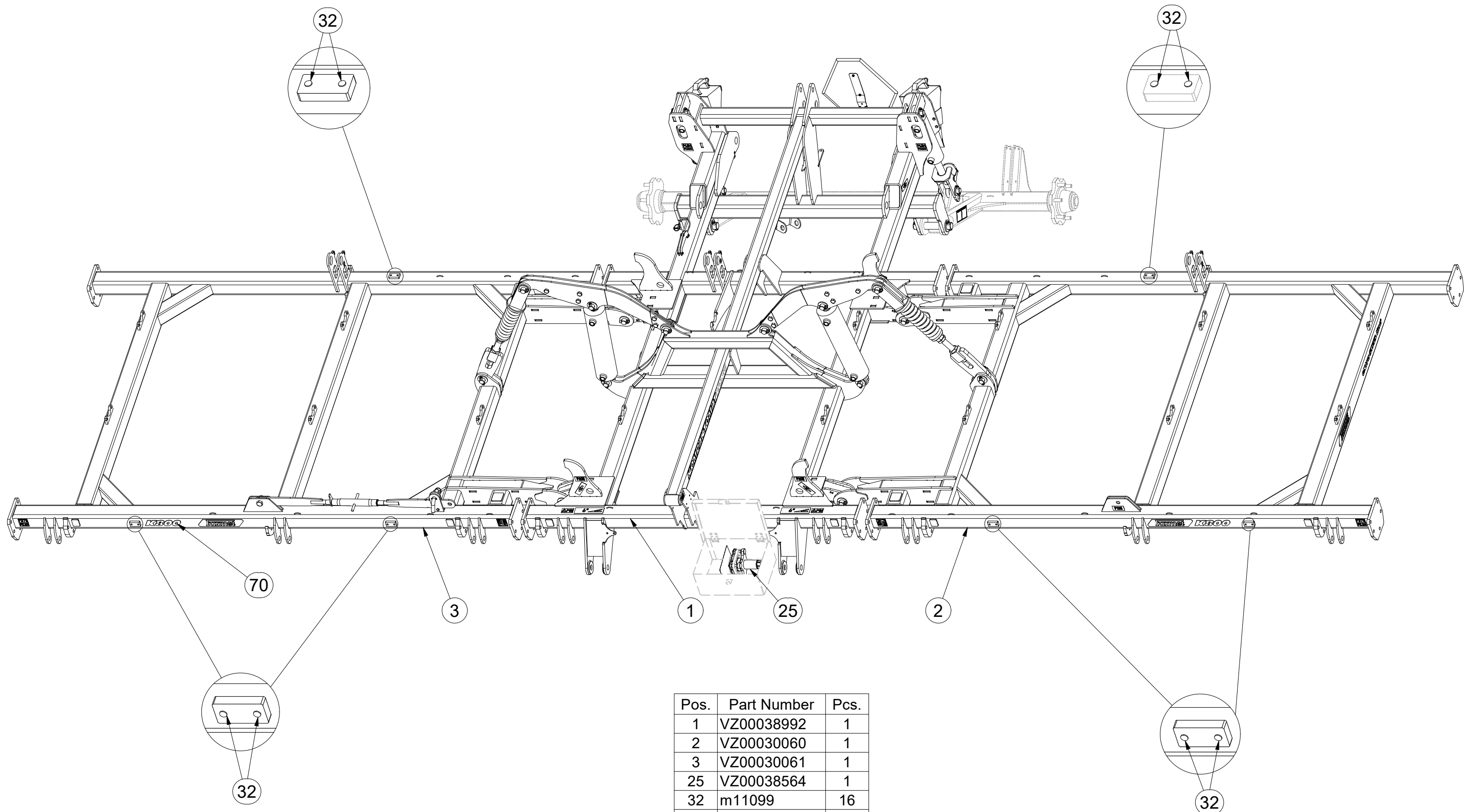

Pos.	Part Number	Pcs.
1	VZ00038992	1
2	VZ00030060	1
3	VZ00030061	1
25	VZ00038564	1
32	m11099	16
70	m22758	1

☉ POLOTOVAR STROJE

Ⓧ MASCHINEN-HALBFABRIKAT

Ⓧ MACHINE - SEMI-PRODUIT

Ⓧ SEMIFINISHED MACHINE

Ⓧ ПОЛУФАБРИКАТ МАШИНЫ

Ⓧ PÓLFABRYKAT MASZYN



**VZ00040141**

Pos.	Part Number	Pcs.
1	VZ00038992	1
2	VZ00030060	1
6	4021664	2
9	4005363	2
10	4007641	4
12	4014569	2
13	4007584	2
33	m02579	2
42	m14143	36
50	m03775	36
54	m04043	2
61	m14029	36

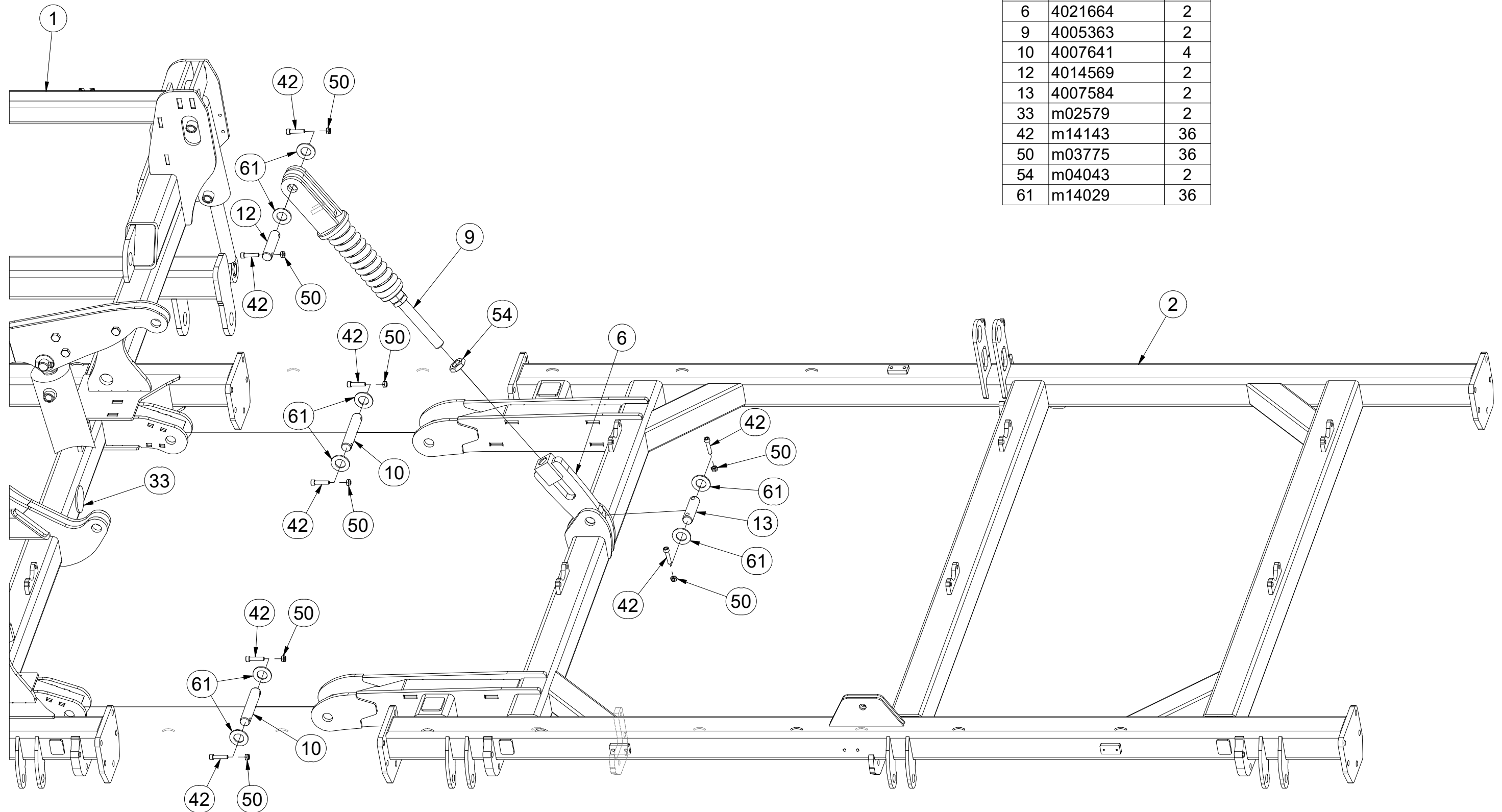



Ⓒ POLOTOVAR STROJE

Ⓓ MASCHINEN-HALBFABRIKAT

Ⓕ MACHINE - SEMI-PRODUIT

Ⓖ SEMIFINISHED MACHINE

Ⓡ ПОЛУФАБРИКАТ МАШИНЫ

Ⓢ PÓLFABRYKAT MASZYN



**VZ00040141**

Pos.	Part Number	Pcs.	Pos.	Part Number	Pcs.
1	VZ00038992	1	33	m02579	2
3	VZ00030061	1	35	m10454	2
6	4021664	2	41	m01096	1
9	4005363	2	42	m14143	36
10	4007641	4	44	m04241	1
12	4014569	2	50	m03775	36
13	4007584	2	51	m04503	9
18	4003966	1	53	m05648	1
19	4012011	1	54	m04043	2
			61	m14029	36

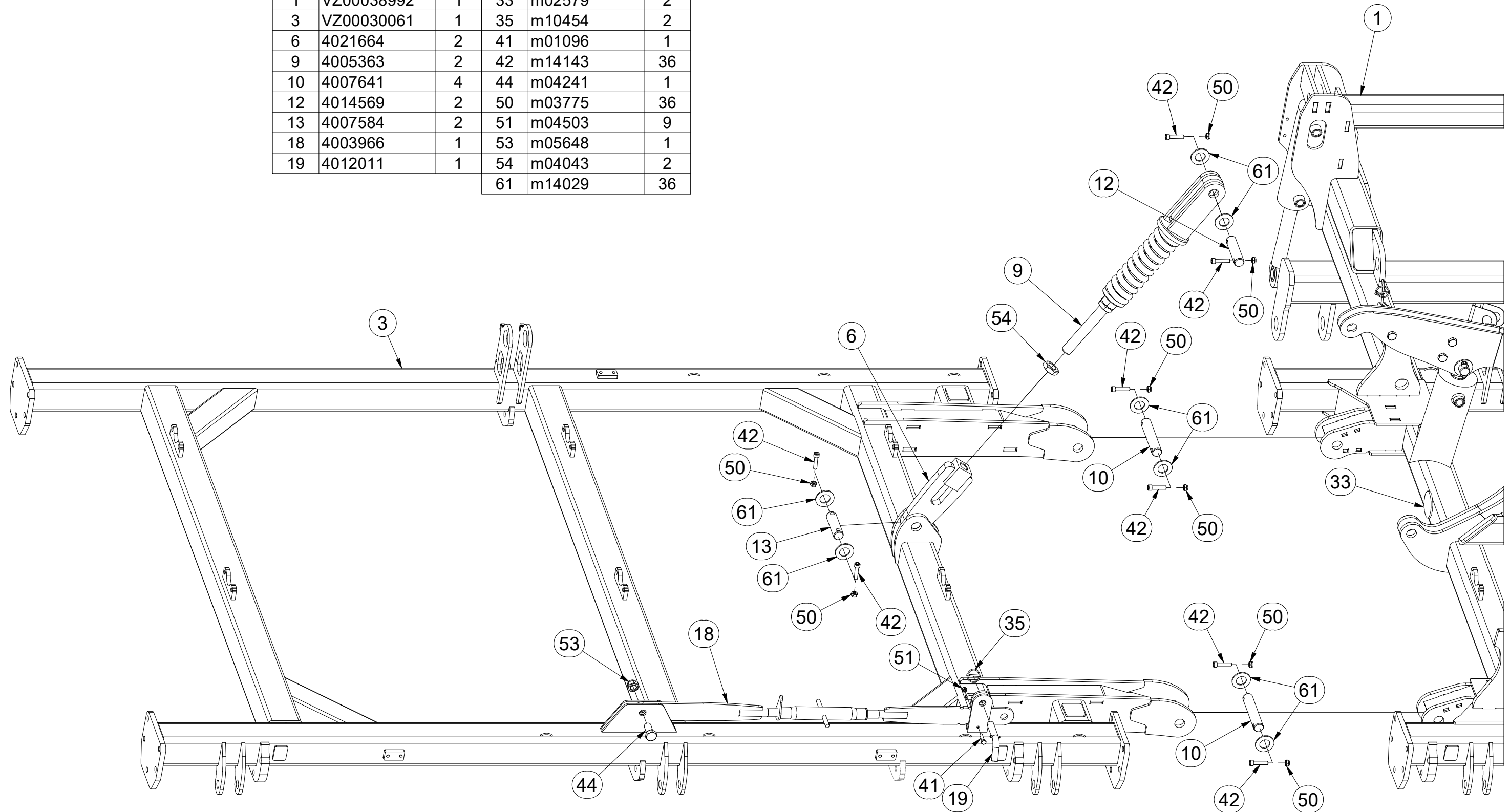

Ⓒ POLOTOVAR STROJE

Ⓓ MASCHINEN-HALBFABRIKAT

Ⓕ MACHINE - SEMI-PRODUIT

Ⓖ SEMIFINISHED MACHINE

Ⓡ ПОЛУФАБРИКАТ МАШИНЫ

Ⓟ PÓŁFABRYKAT MASZYNY



**VZ00040141**

Pos.	Part Number	Pcs.
1	VZ00038992	1
4	VZ00040412	1
5	VZ00040413	1
7	VZ00013004	2
11	4007640	4
15	4008234	4
42	m14143	36
50	m03775	36
61	m14029	36

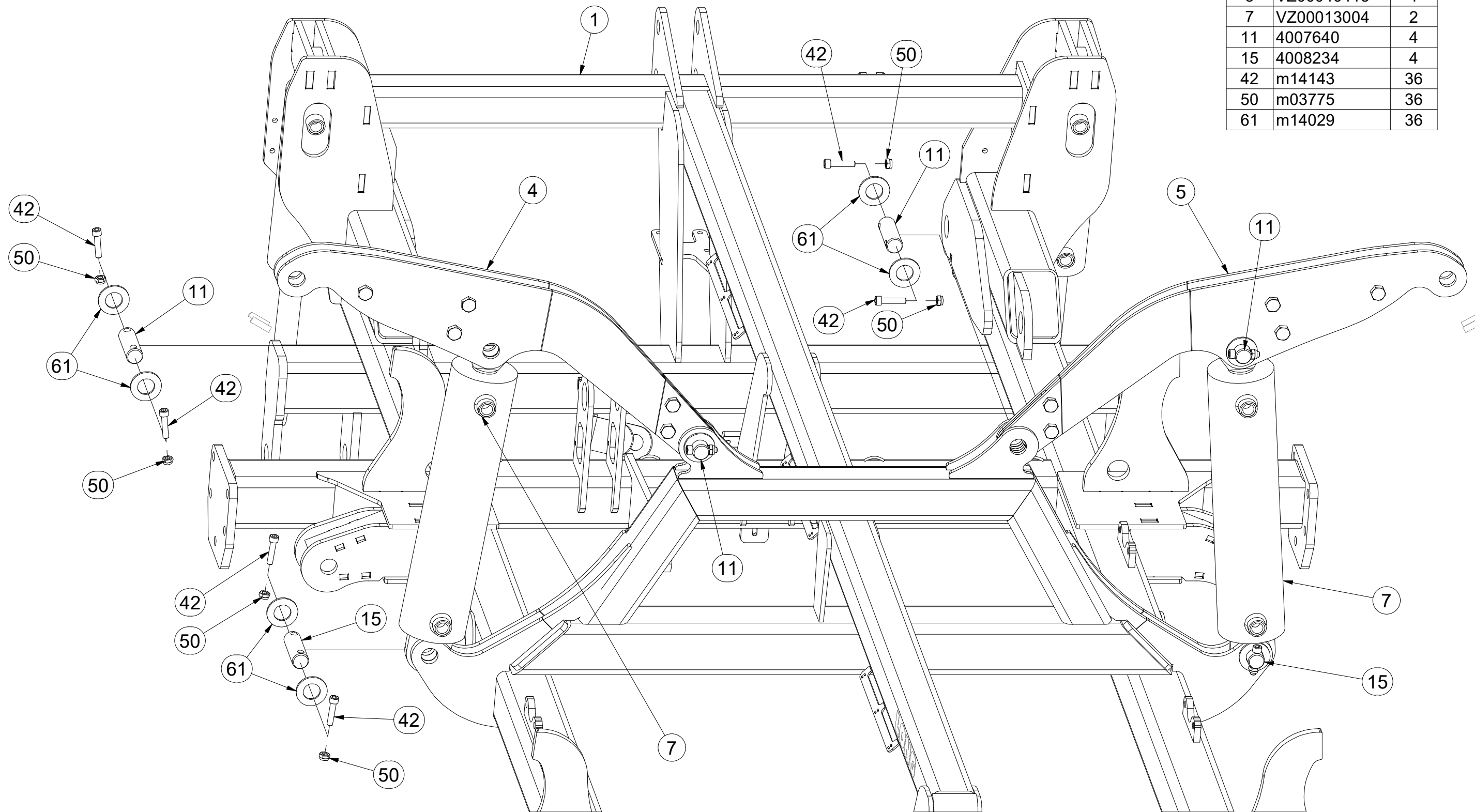

☉ POLOTOVAR STROJE

☉ MASCHINEN-HALBFABRIKAT

☉ MACHINE - SEMI-PRODUIT

☉ SEMIFINISHED MACHINE

☉ ПОЛУФАБРИКАТ МАШИНЫ

☉ PÓLFABRYKAT MASZYNY



**VZ00040141**

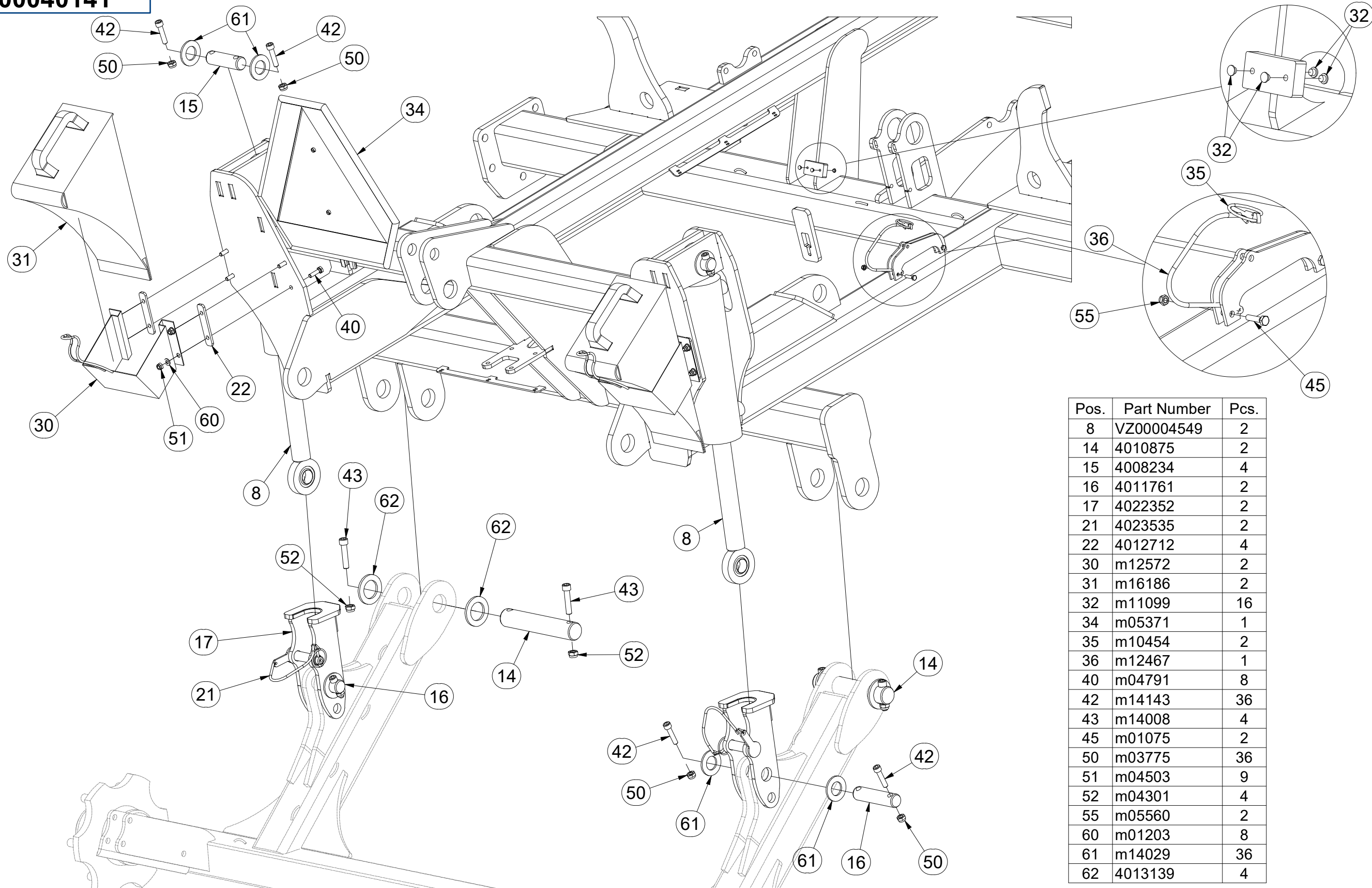

Pos.	Part Number	Pcs.
8	VZ00004549	2
14	4010875	2
15	4008234	4
16	4011761	2
17	4022352	2
21	4023535	2
22	4012712	4
30	m12572	2
31	m16186	2
32	m11099	16
34	m05371	1
35	m10454	2
36	m12467	1
40	m04791	8
42	m14143	36
43	m14008	4
45	m01075	2
50	m03775	36
51	m04503	9
52	m04301	4
55	m05560	2
60	m01203	8
61	m14029	36
62	4013139	4

Ⓒ POLOTOVAR STROJE

Ⓓ MASCHINEN-HALBFABRIKAT

Ⓕ MACHINE - SEMI-PRODUIT

Ⓖ SEMIFINISHED MACHINE

Ⓡ ПОЛУФАБРИКАТ МАШИНЫ

Ⓟ PÓŁFABRYKAT MASZYNY



**m22758**

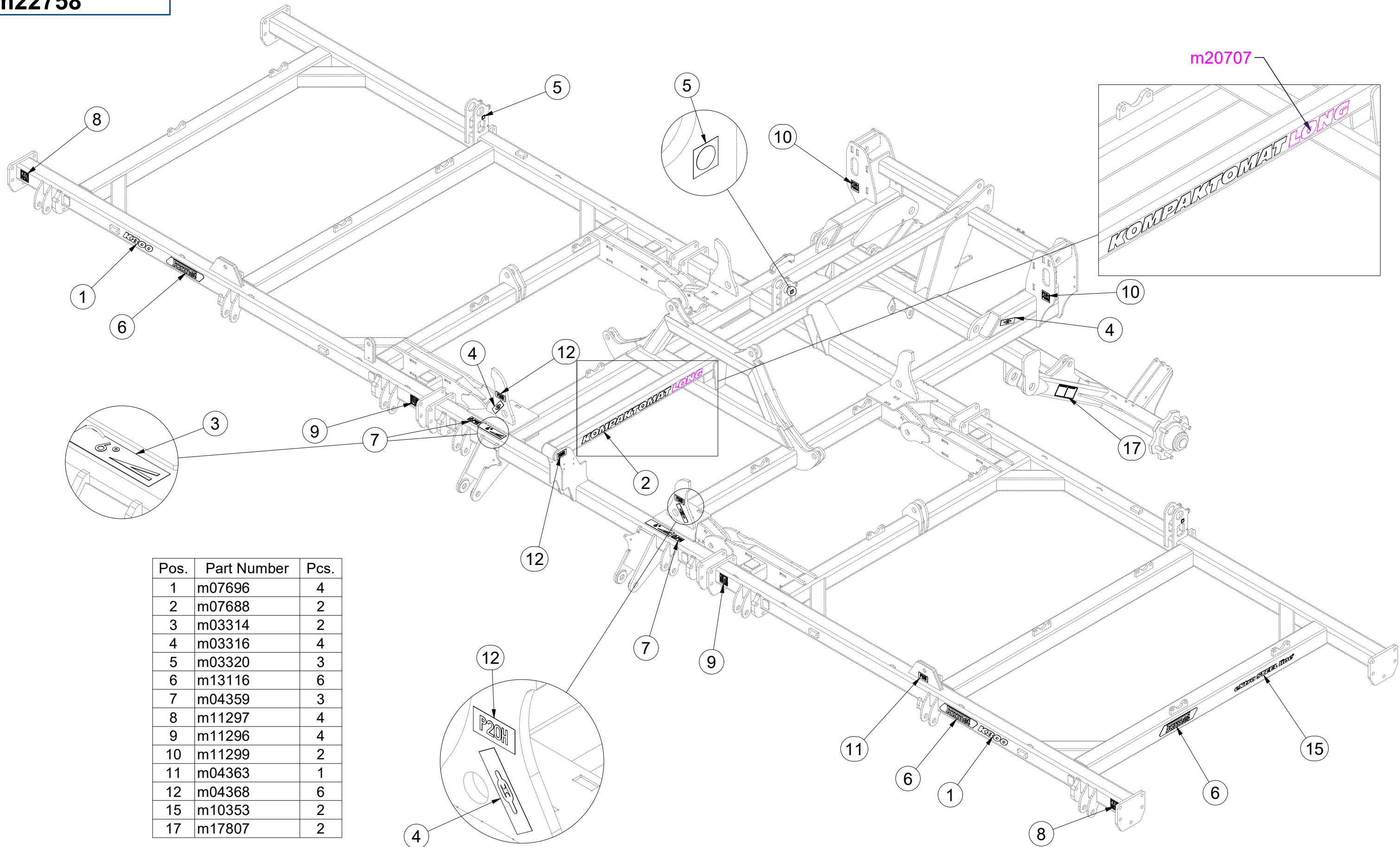

Pos.	Part Number	Pcs.
1	m07696	4
2	m07688	2
3	m03314	2
4	m03316	4
5	m03320	3
6	m13116	6
7	m04359	3
8	m11297	4
9	m11296	4
10	m11299	2
11	m04363	1
12	m04368	6
15	m10353	2
17	m17807	2

Ⓒ POLOTOVAR STROJE

Ⓓ MASCHINEN-HALBFABRIKAT

Ⓕ MACHINE - SEMI-PRODUIT

Ⓖ SEMIFINISHED MACHINE

Ⓡ ПОЛУФАБРИКАТ МАШИНЫ

Ⓟ PÓŁFABRYKAT MASZYN



**m22758**

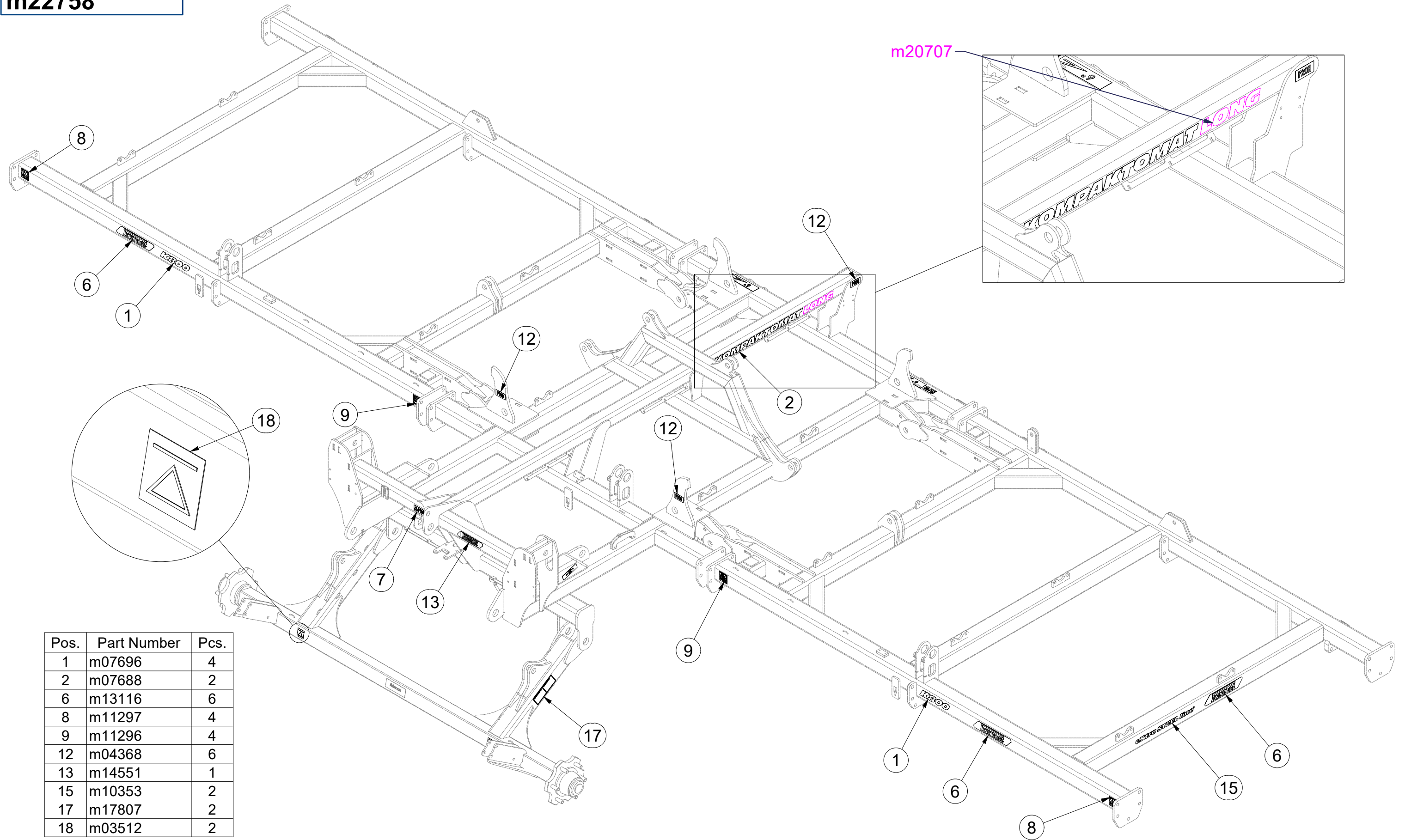

Pos.	Part Number	Pcs.
1	m07696	4
2	m07688	2
6	m13116	6
8	m11297	4
9	m11296	4
12	m04368	6
13	m14551	1
15	m10353	2
17	m17807	2
18	m03512	2

(CZ) RÁM  
 (D) RAHMEN  
 (F) CHASSIS

(GB) FRAME  
 (RU) ПАМА  
 (PL) RAMA



**VZ00040412**

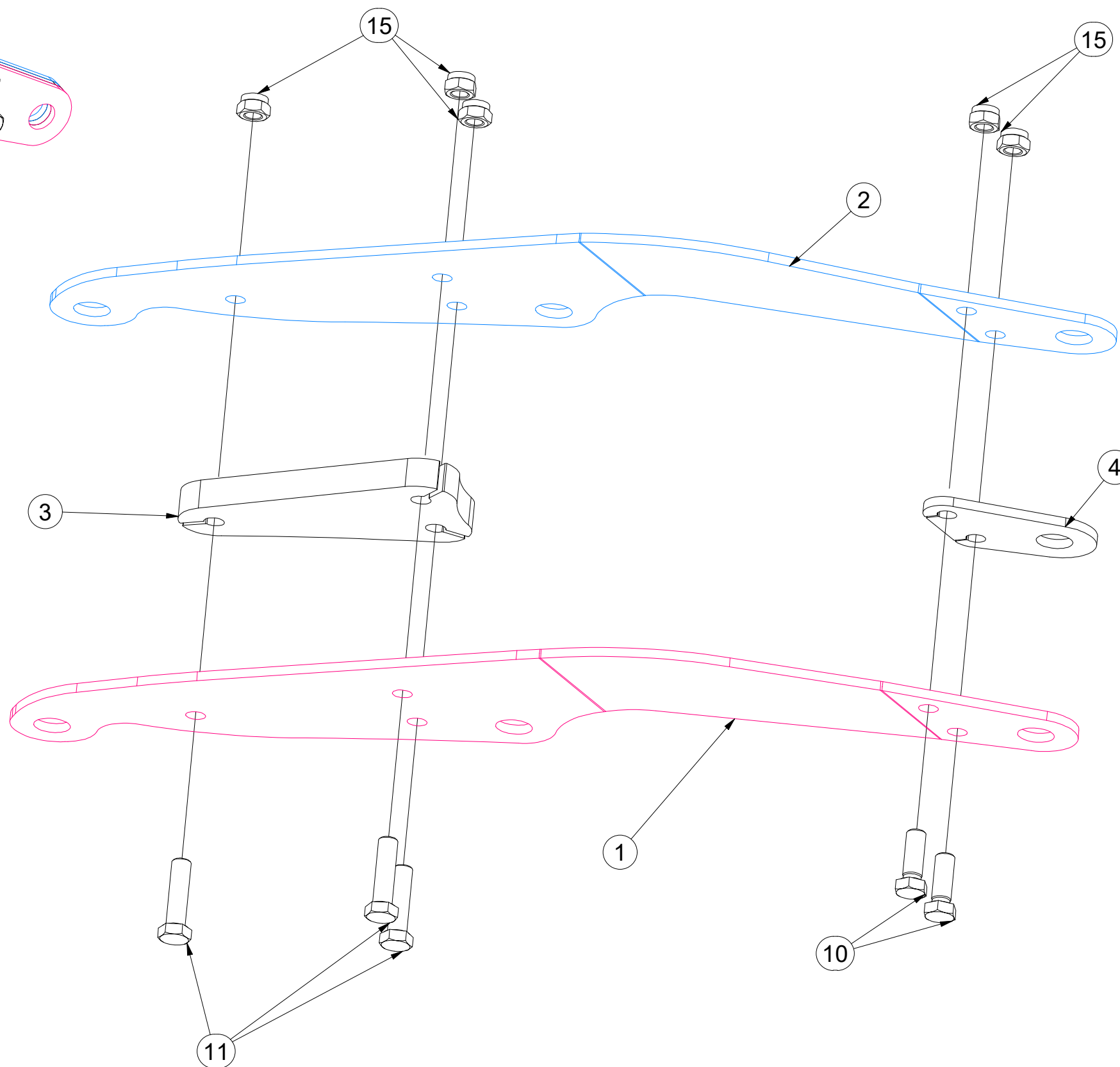
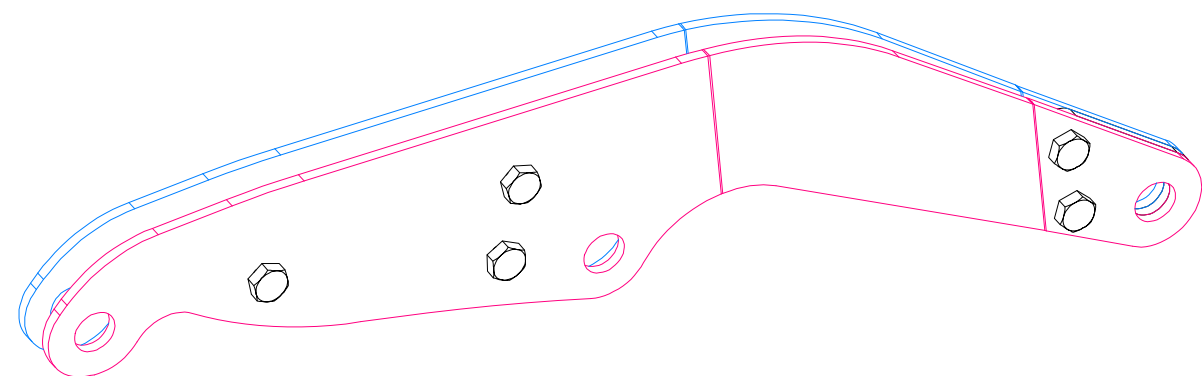

Pos.	Part Number	Pcs.
1	VZ00040414	1
2	VZ00040415	1
3	VZ00004778	1
4	VZ00002684	1
10	m02254	2
11	m00619	3
15	m03683	5

(CZ) RÁM  
 (D) RAHMEN  
 (F) CHASSIS

(GB) FRAME  
 (RU) ПАМА  
 (PL) RAMA



**VZ00040413**

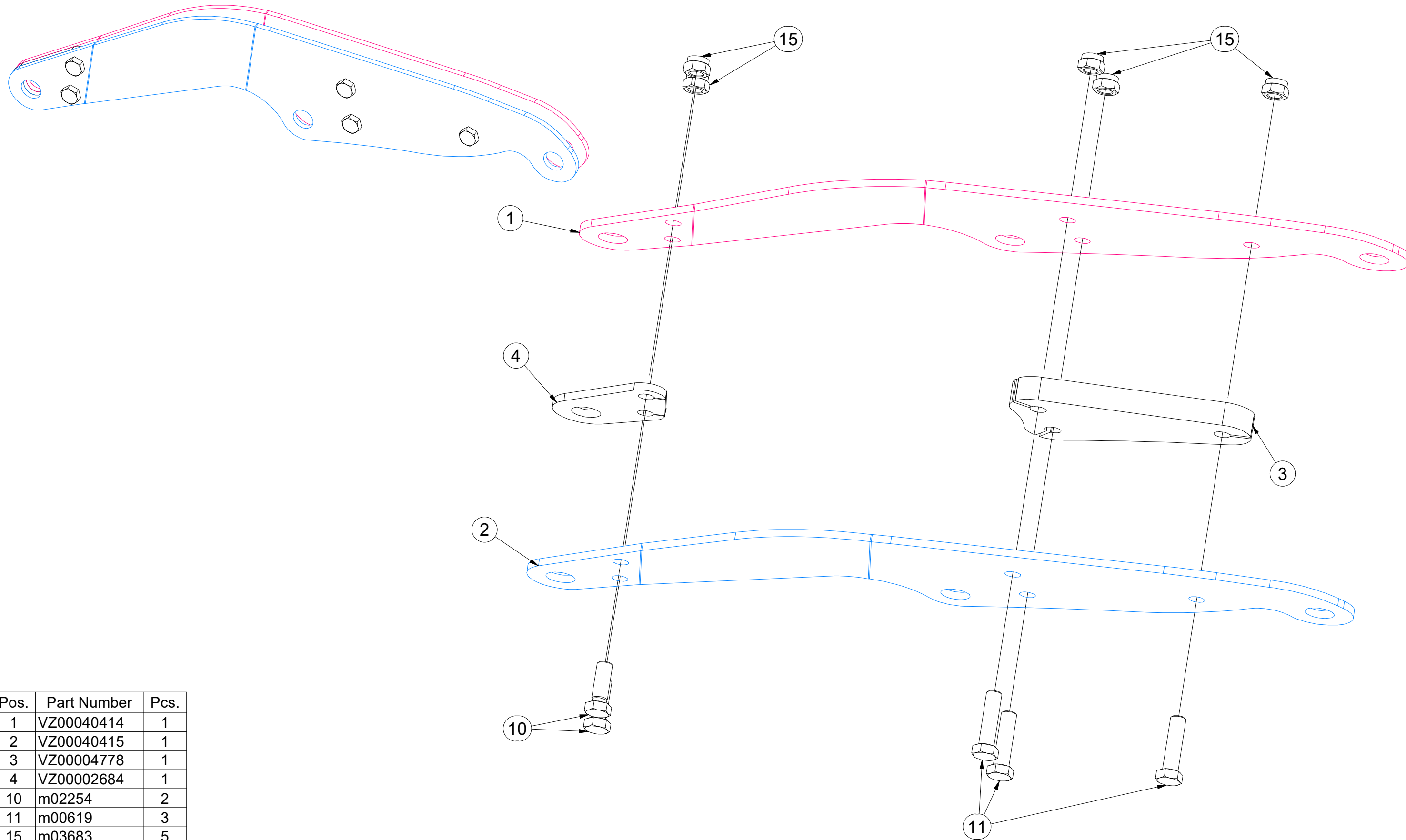

Pos.	Part Number	Pcs.
1	VZ00040414	1
2	VZ00040415	1
3	VZ00004778	1
4	VZ00002684	1
10	m02254	2
11	m00619	3
15	m03683	5

ⒸZ HYDRAULIKA STROJE

Ⓓ HYDRAULIK DER MASCHINE

Ⓕ HYDRAULIQUE DE LA MACHINE

**VZ00027320**

ⒸB MACHINE HYDRAULICS

Ⓔ ГИДРАВЛИКА МАШИНЫ

Ⓖ HYDRAULIKA MASZYN

**Farmet**

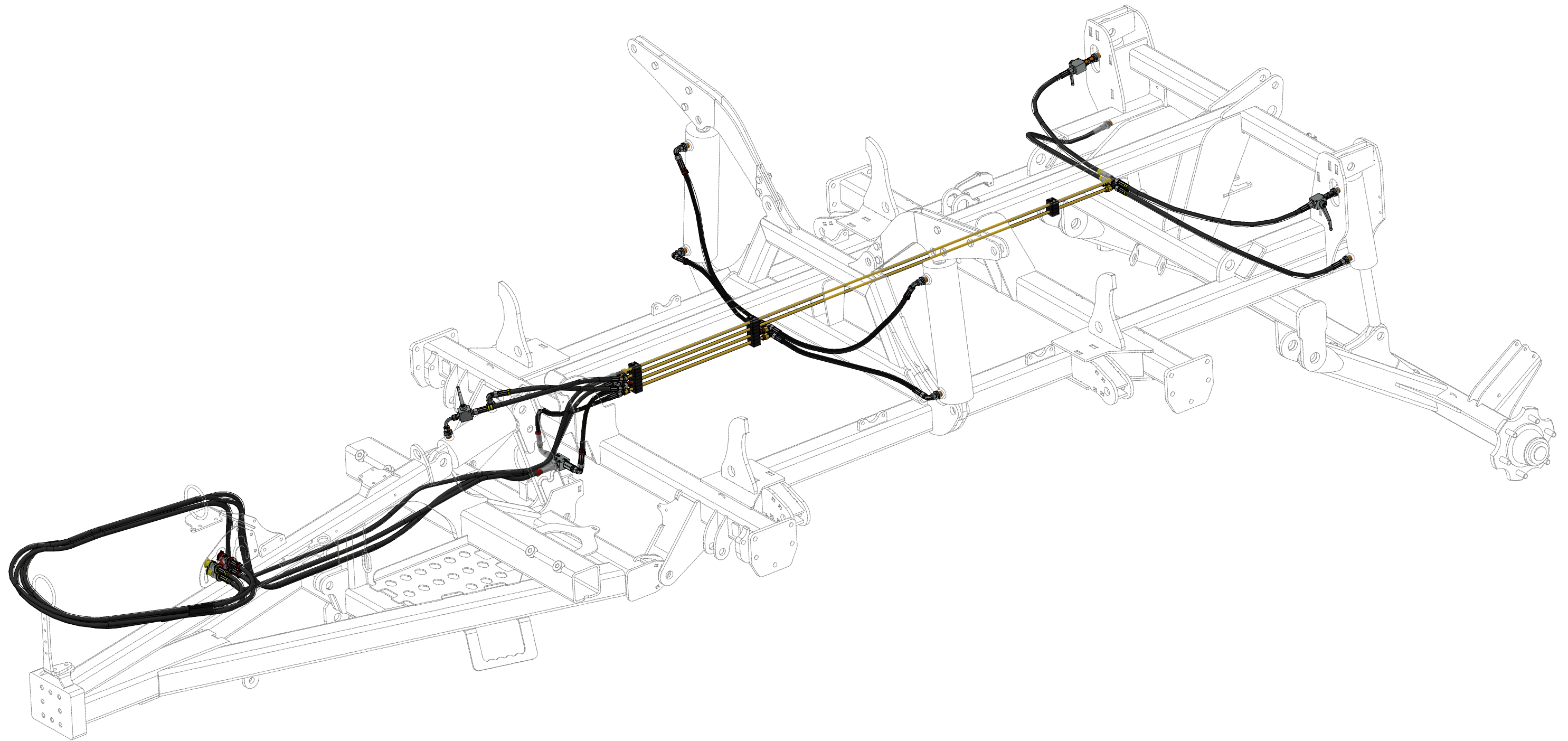



ⒸZ HYDRAULIKA STROJE

Ⓓ HYDRAULIK DER MASCHINE

Ⓕ HYDRAULIQUE DE LA MACHINE

ⒸB MACHINE HYDRAULICS

ⒸR ГИДРАВЛИКА МАШИНЫ

ⒸL HYDRAULIKA MASZYN



**VZ00027320**

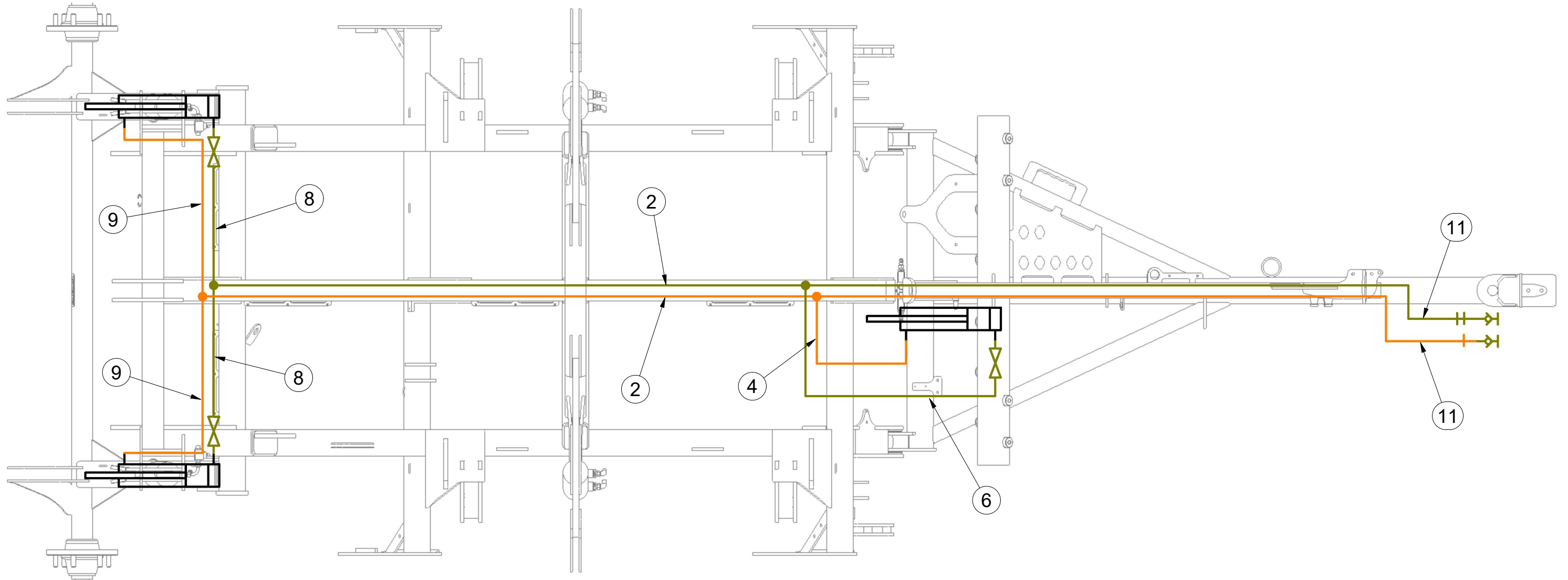

Pos.	Part Number	Pcs.
2	m04803	2
4	m09629	1
6	m07909	3
8	m07364	2
9	m04669	2
11	m04664	2

ⒸZ HYDRAULIKA STROJE

Ⓓ HYDRAULIK DER MASCHINE

Ⓕ HYDRAULIQUE DE LA MACHINE

ⒼB MACHINE HYDRAULICS

Ⓔ RU ГИДРАВЛИКА МАШИНЫ

Ⓗ PL HYDRAULIKA MASZYN



VZ00027320

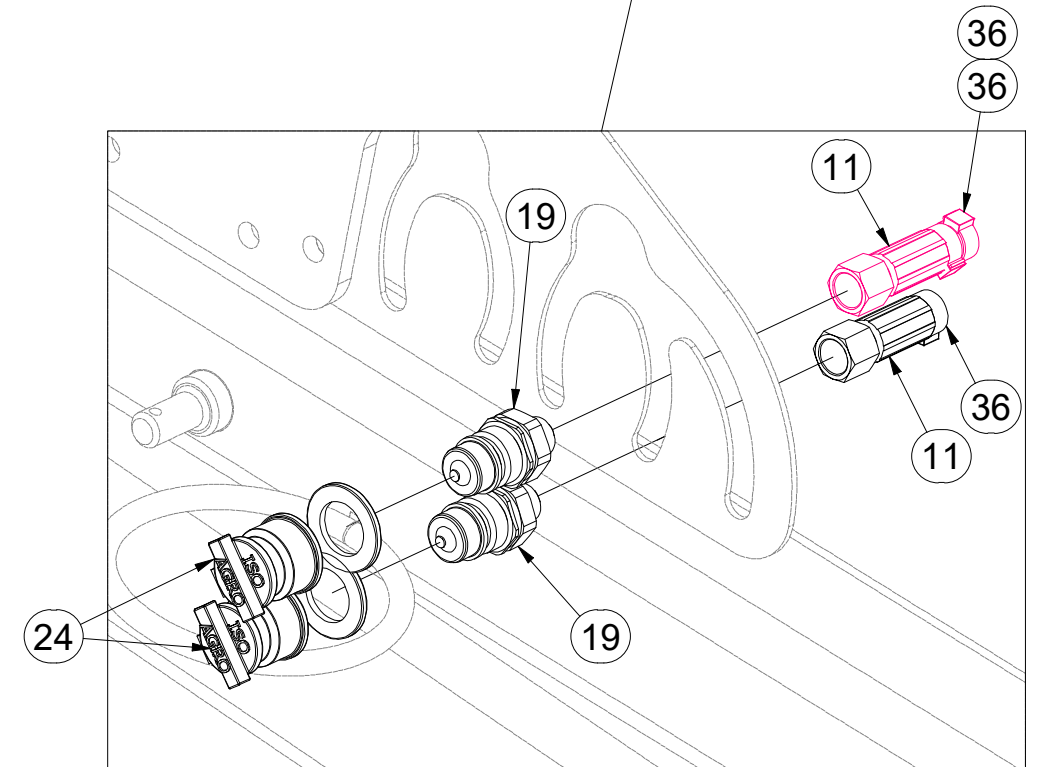
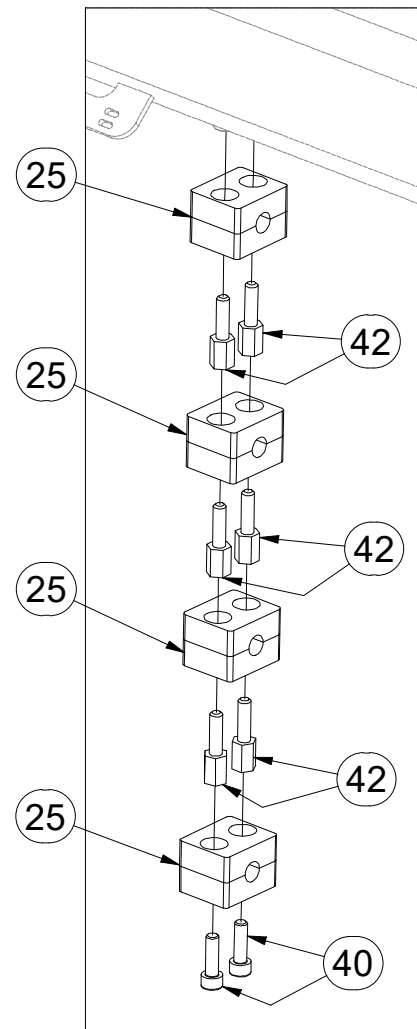
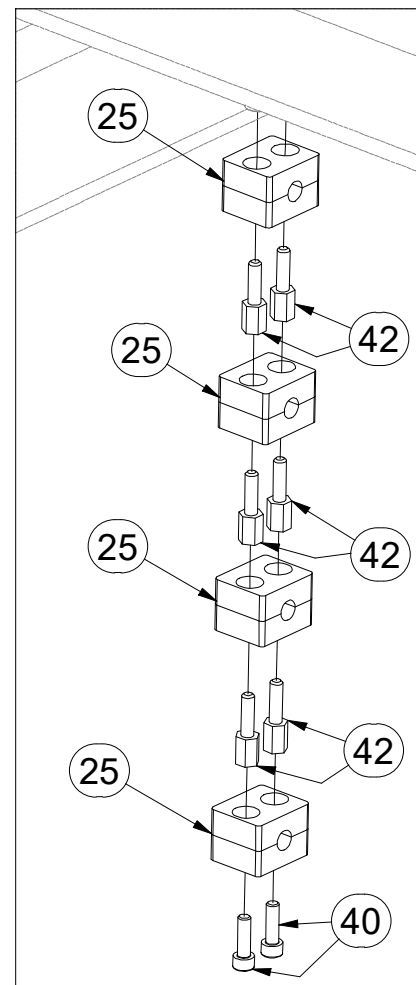
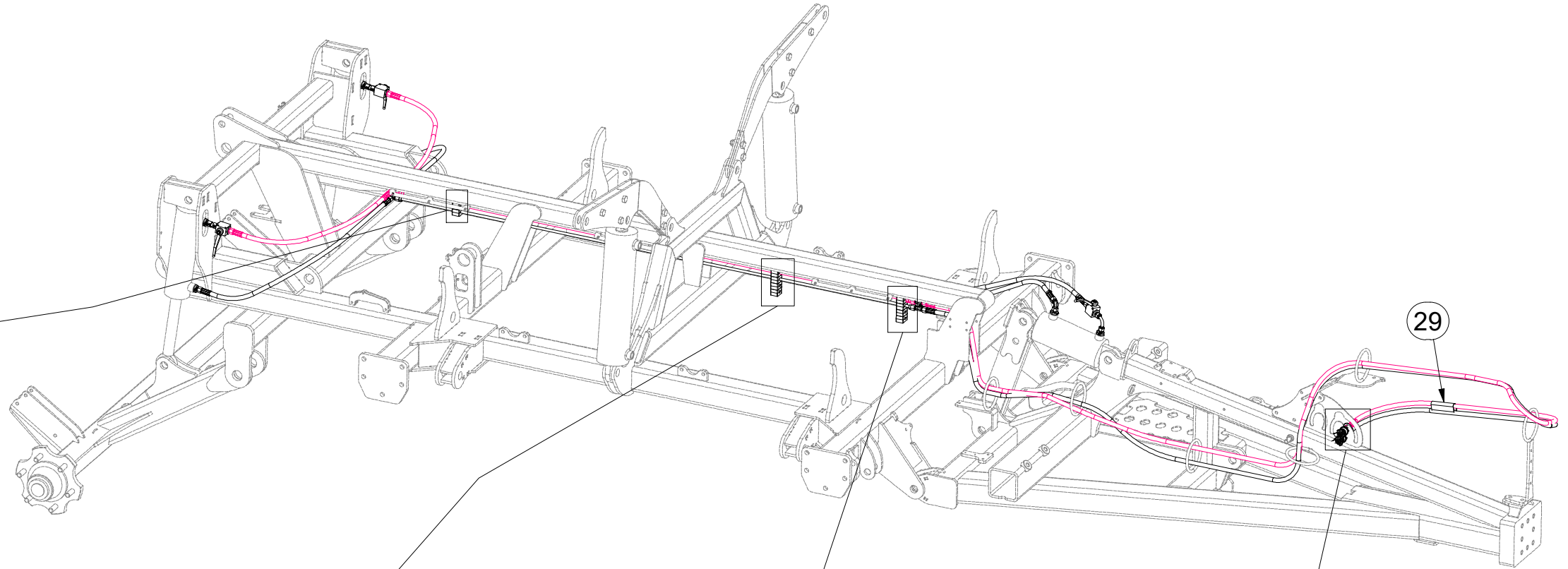
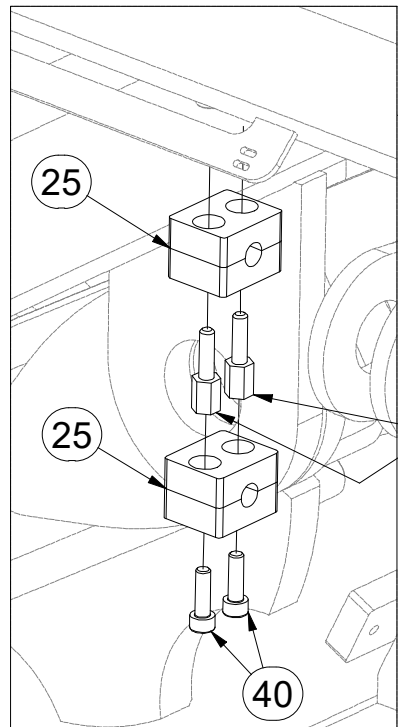
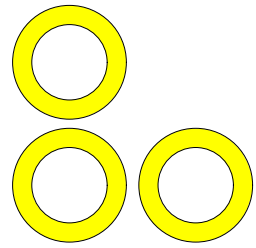

Pos.	Part Number	Pcs.
11	m04664	2
19	m03849	4
24	m04023	2
25	m04009	10
29	m11183	2
36	m11289	18
40	m04346	6
42	m04021	14

Ⓒ HYDRAULIKA STROJE

Ⓓ HYDRAULIK DER MASCHINE

Ⓕ HYDRAULIQUE DE LA MACHINE

Ⓖ MACHINE HYDRAULICS

Ⓡ ГИДРАВЛИКА МАШИНЫ

Ⓟ HYDRAULIKA MASZYNY



**VZ00027320**

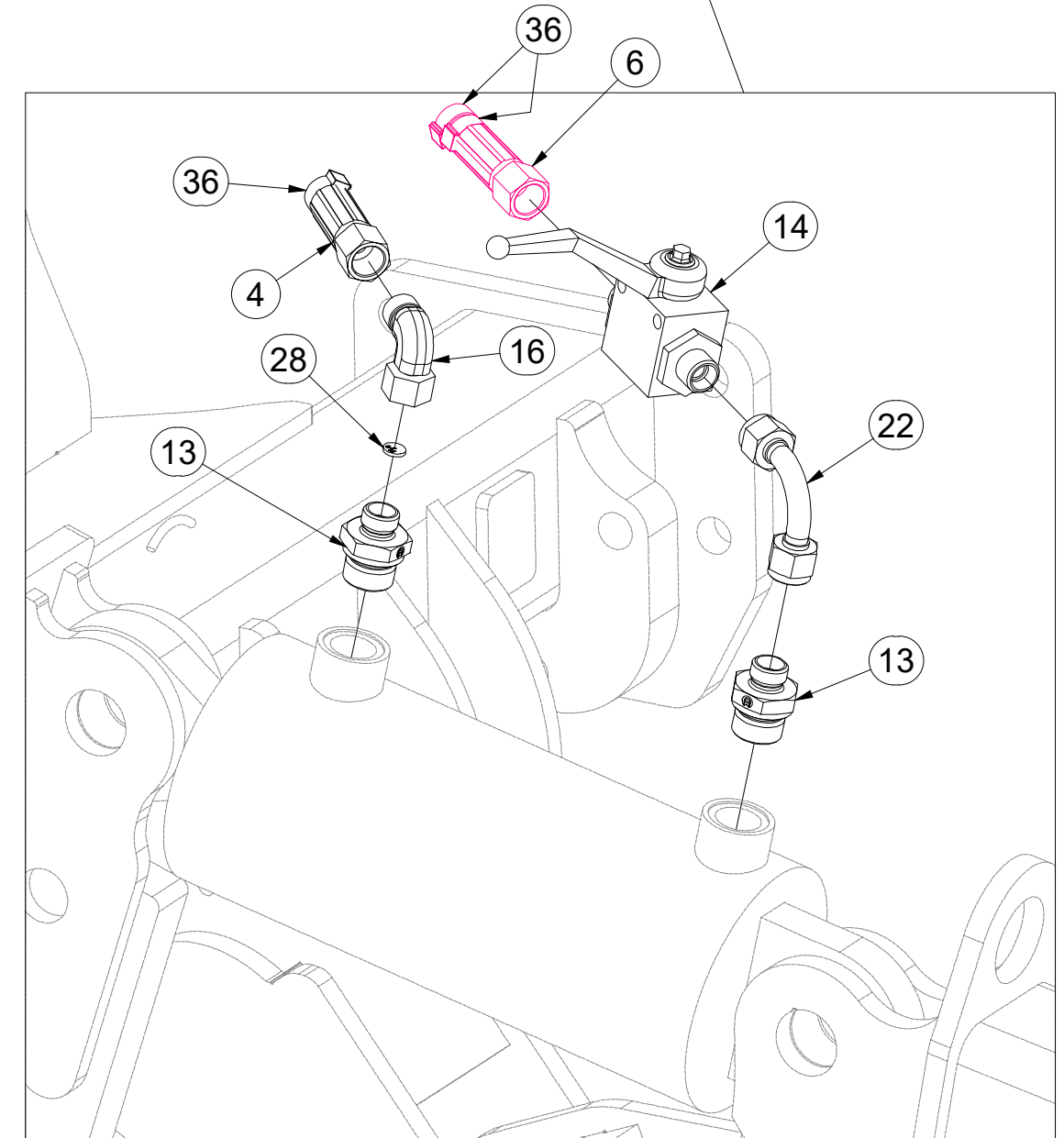
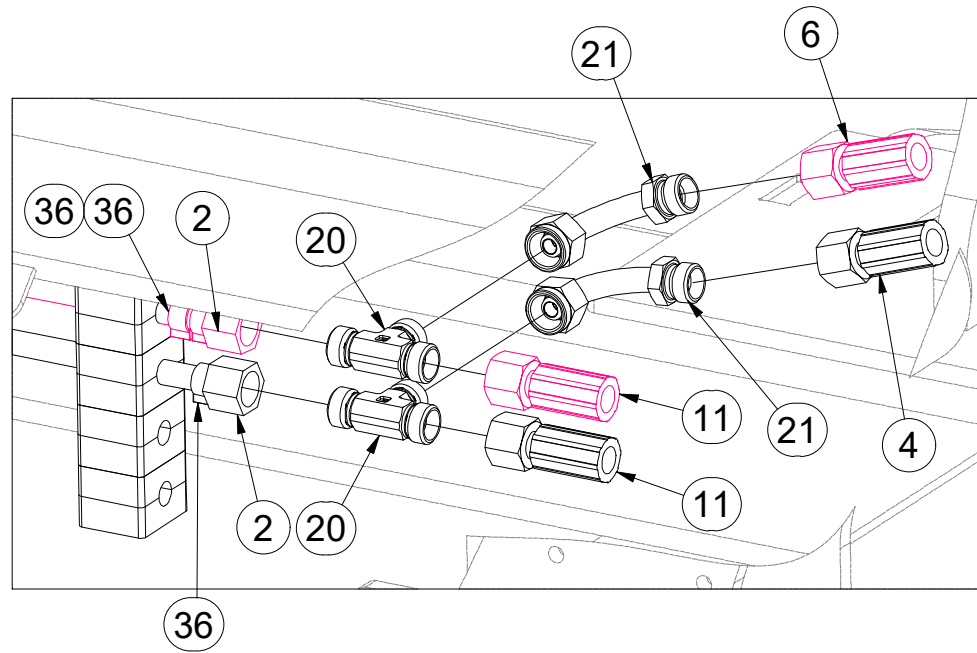
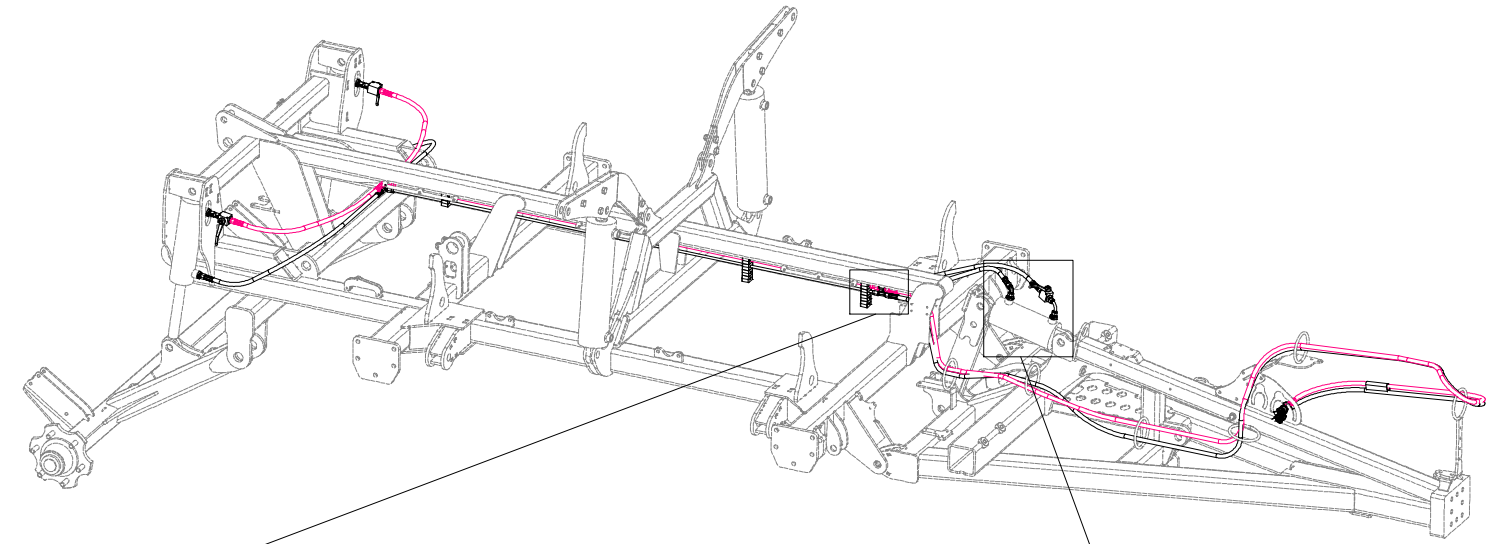
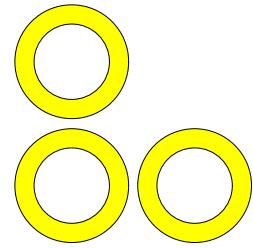

Pos.	Part Number	Pcs.
2	m04803	2
4	m09629	1
6	m07909	3
11	m04664	2
13	m09934	10
14	m04623	3
16	m06803	7
20	m03889	6
21	m04024	2
22	m04621	1
28	m10779	1
36	m11289	18

CZ HYDRAULIKA STROJE  
 D HYDRAULIK DER MASCHINE  
 F HYDRAULIQUE DE LA MACHINE

GB MACHINE HYDRAULICS  
 RU ГИДРАВЛИКА МАШИНЫ  
 PL HYDRAULIKA MASZYN



**VZ00027320**

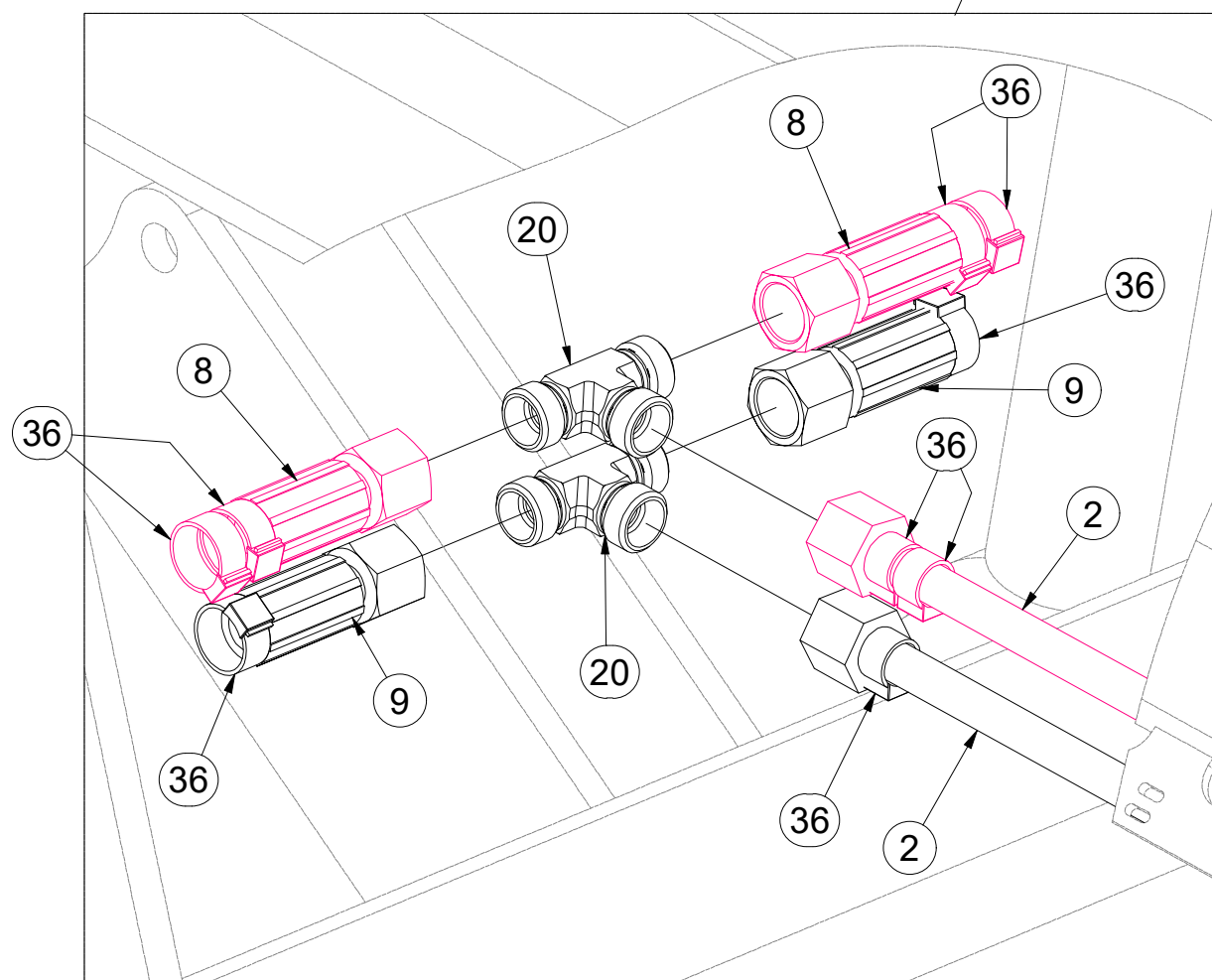
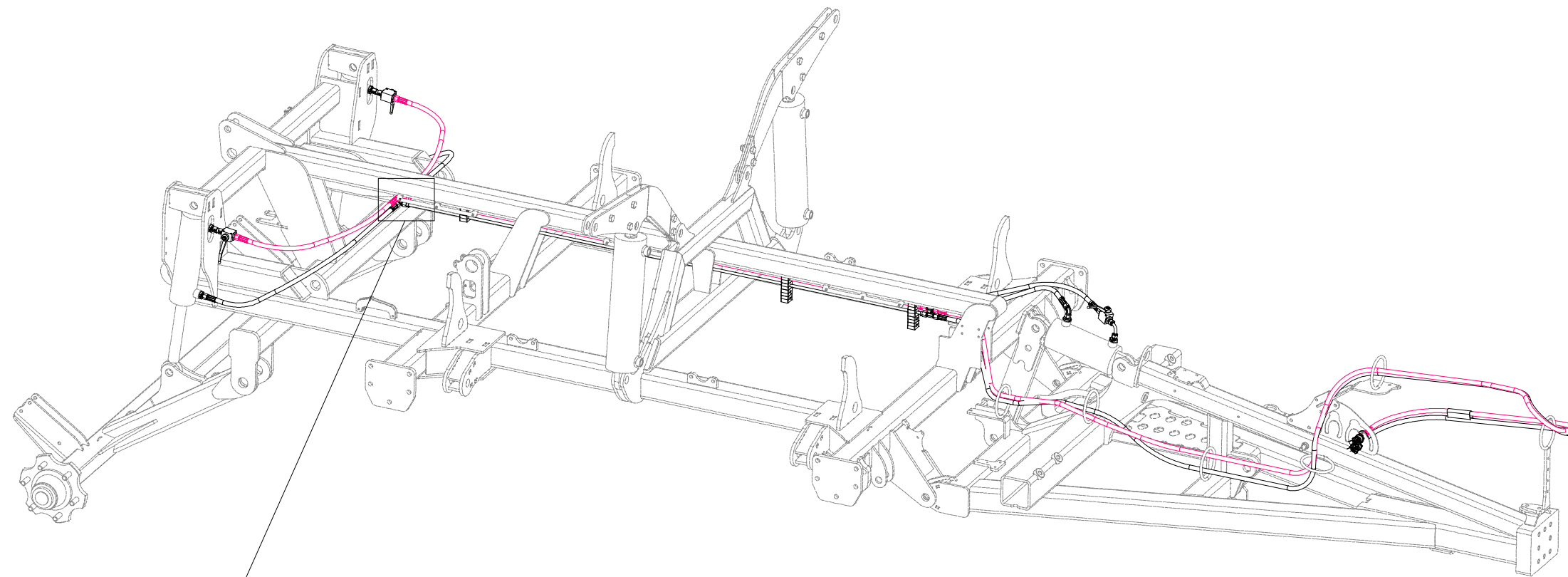
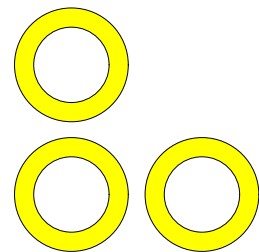

Pos.	Part Number	Pcs.
2	m04803	2
8	m07364	2
9	m04669	2
20	m03889	6
36	m11289	18

ⒸZ HYDRAULIKA STROJE

Ⓓ HYDRAULIK DER MASCHINE

Ⓕ HYDRAULIQUE DE LA MACHINE

ⒸB MACHINE HYDRAULICS

ⒸR ГИДРАВЛИКА МАШИНЫ

ⒸL HYDRAULIKA MASZYN



VZ00027320

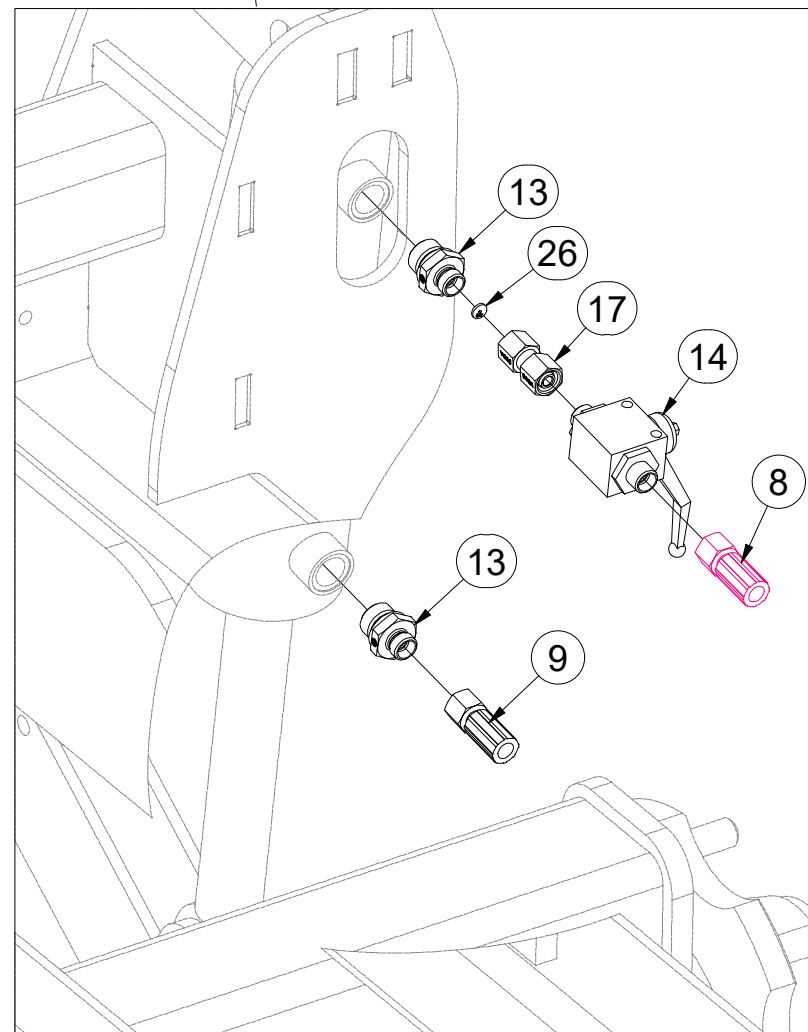
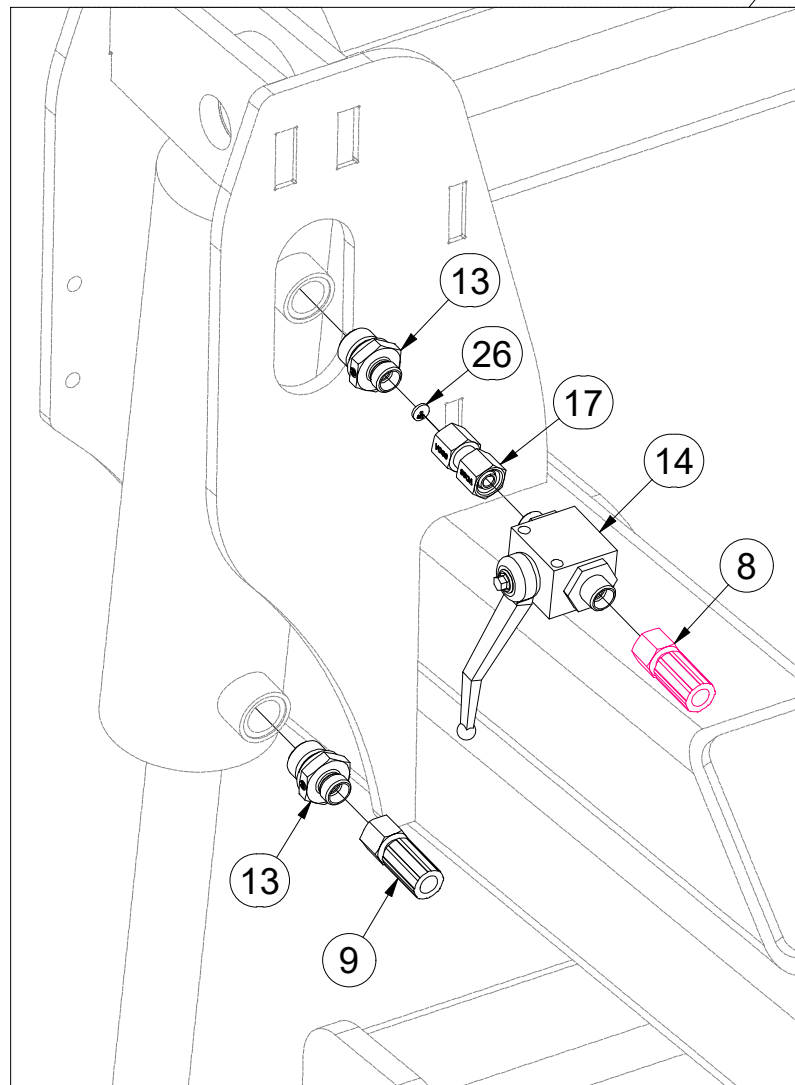
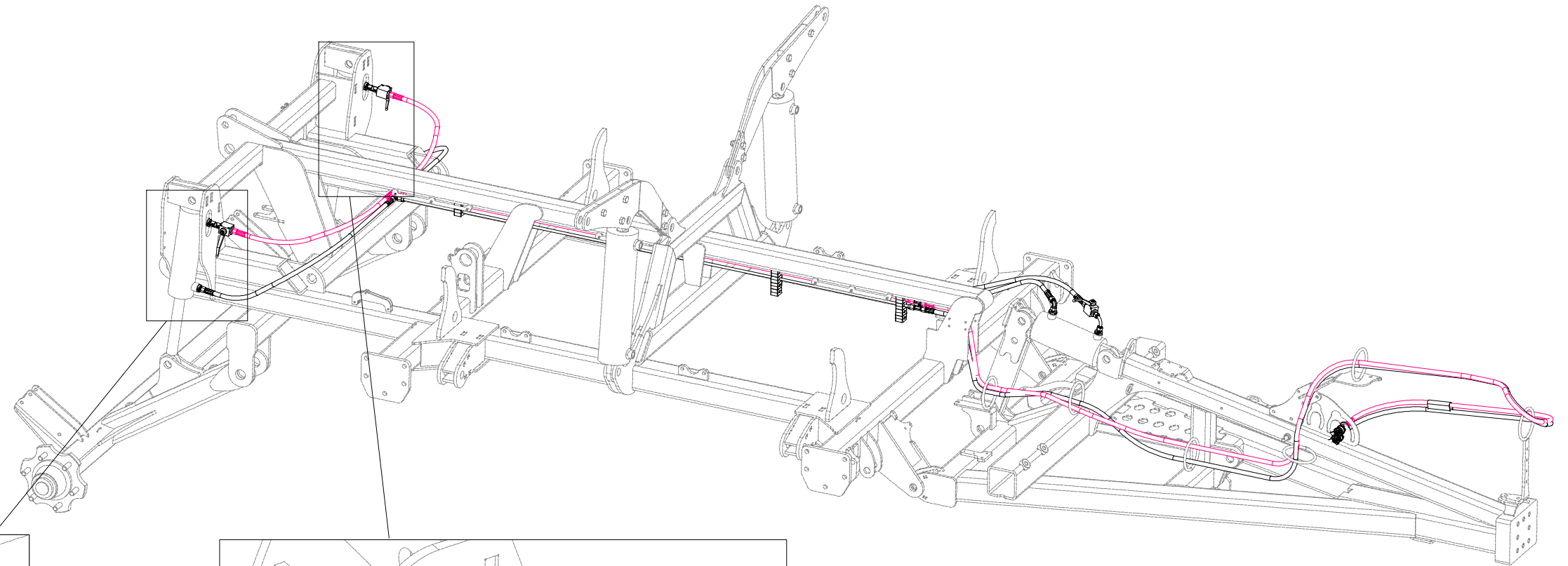
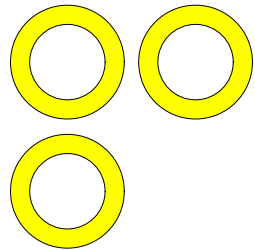

Pos.	Part Number	Pcs.
8	m07364	2
9	m04669	2
13	m09934	10
14	m04623	3
17	m22305	2
26	m10777	2

**VZ00027320**

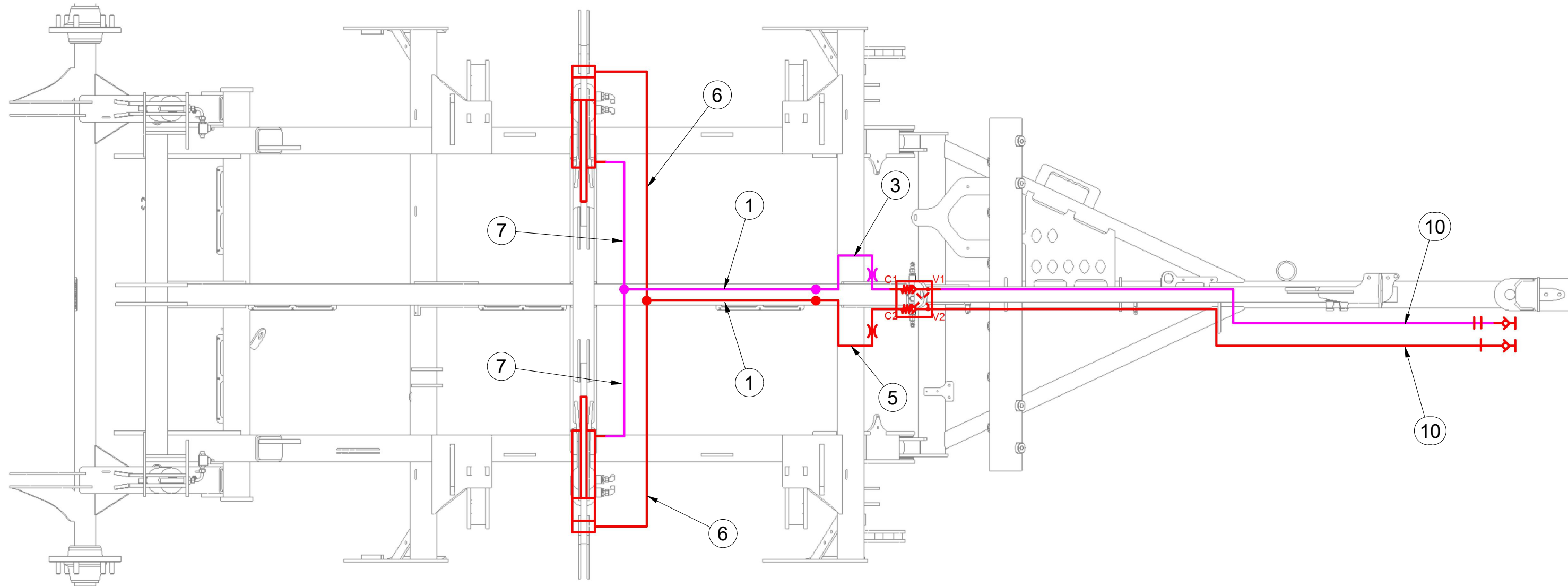

Pos.	Part Number	Pcs.
1	m03975	2
3	m11000	1
5	m04761	1
6	m07909	3
7	m07646	2
10	m04310	2

ⒸZ HYDRAULIKA STROJE

ⒸD HYDRAULIK DER MASCHINE

ⒸF HYDRAULIQUE DE LA MACHINE

ⒸB MACHINE HYDRAULICS

ⒸRU ГИДРАВЛИКА МАШИНЫ

ⒸPL HYDRAULIKA MASZYN



**VZ00027320**

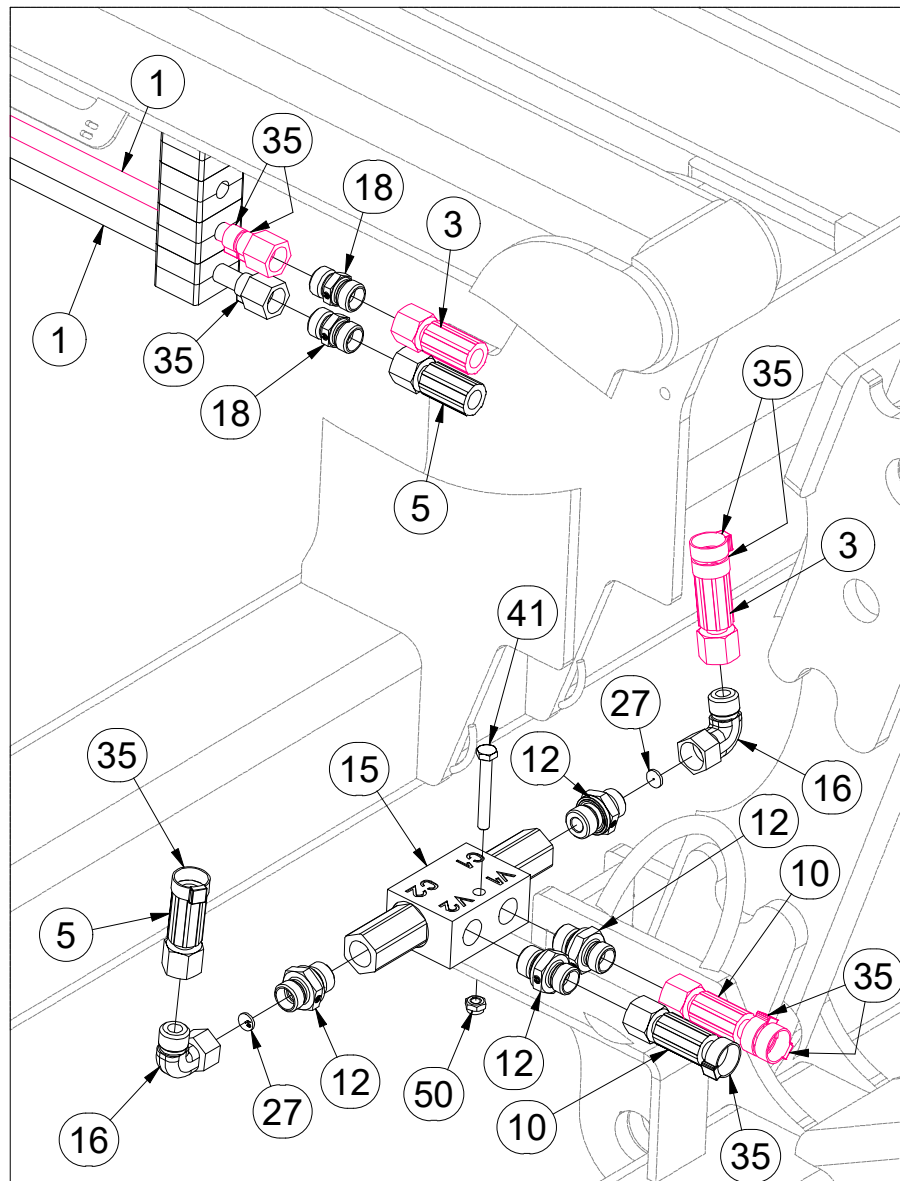
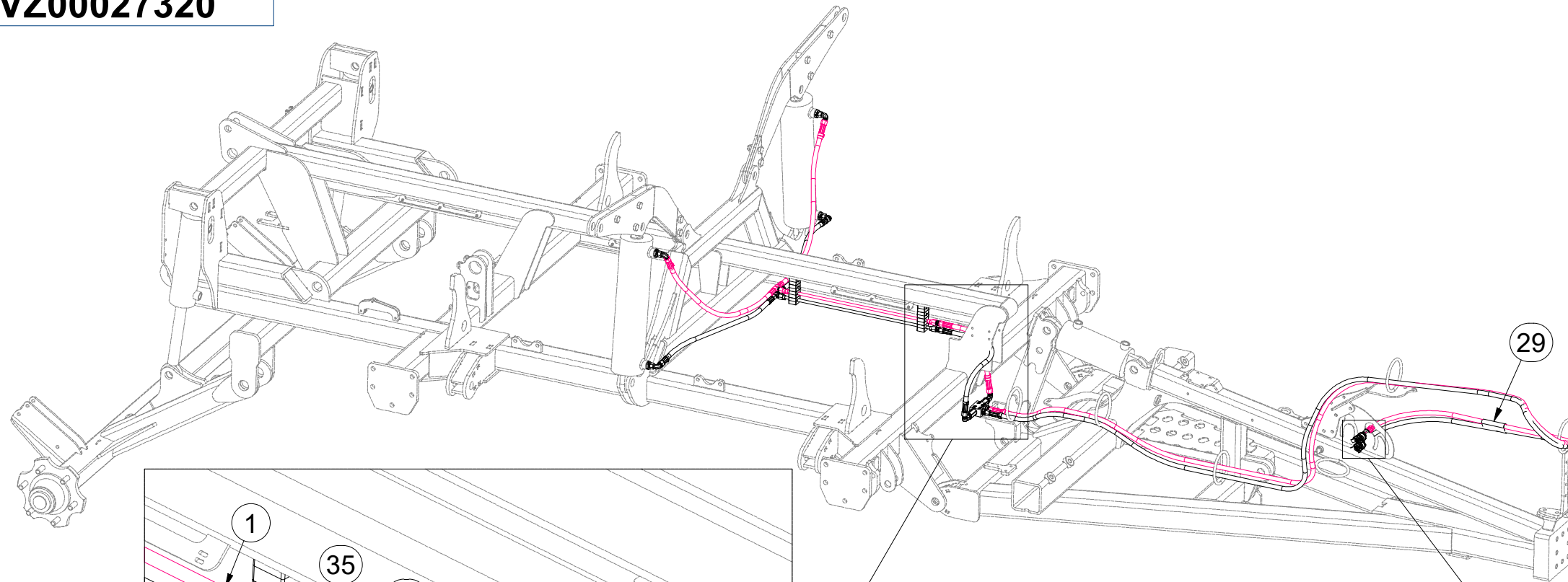
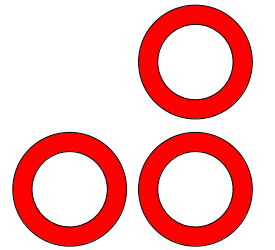

Pos.	Part Number	Pcs.
1	m03975	2
3	m11000	1
5	m04761	1
10	m04310	2
12	m06528	4
15	m06673	1
16	m06803	7
18	m03213	2
19	m03849	4
23	m04022	2
27	m10780	2
29	m11183	2
35	m11294	21
41	m05561	1
50	m05560	1

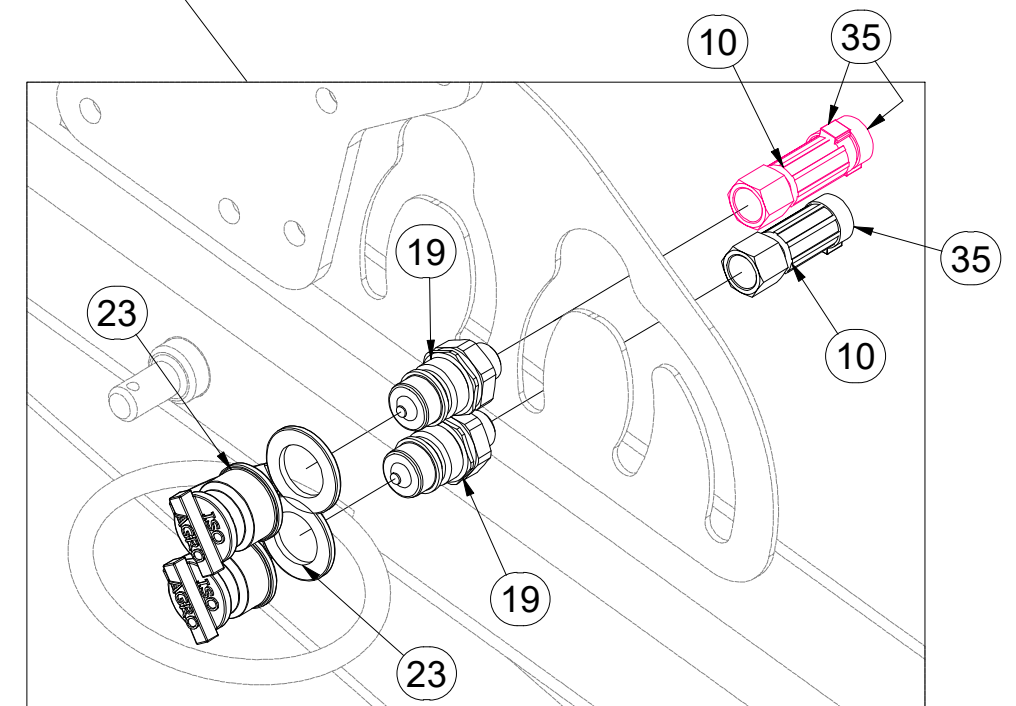

ⒸZ HYDRAULIKA STROJE

Ⓓ HYDRAULIK DER MASCHINE

Ⓕ HYDRAULIQUE DE LA MACHINE

ⒸB MACHINE HYDRAULICS

ⒸR ГИДРАВЛИКА МАШИНЫ

ⒸL HYDRAULIKA MASZYNY



**VZ00027320**

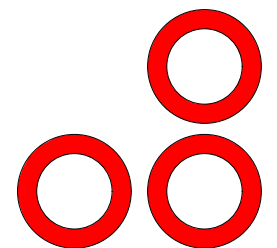
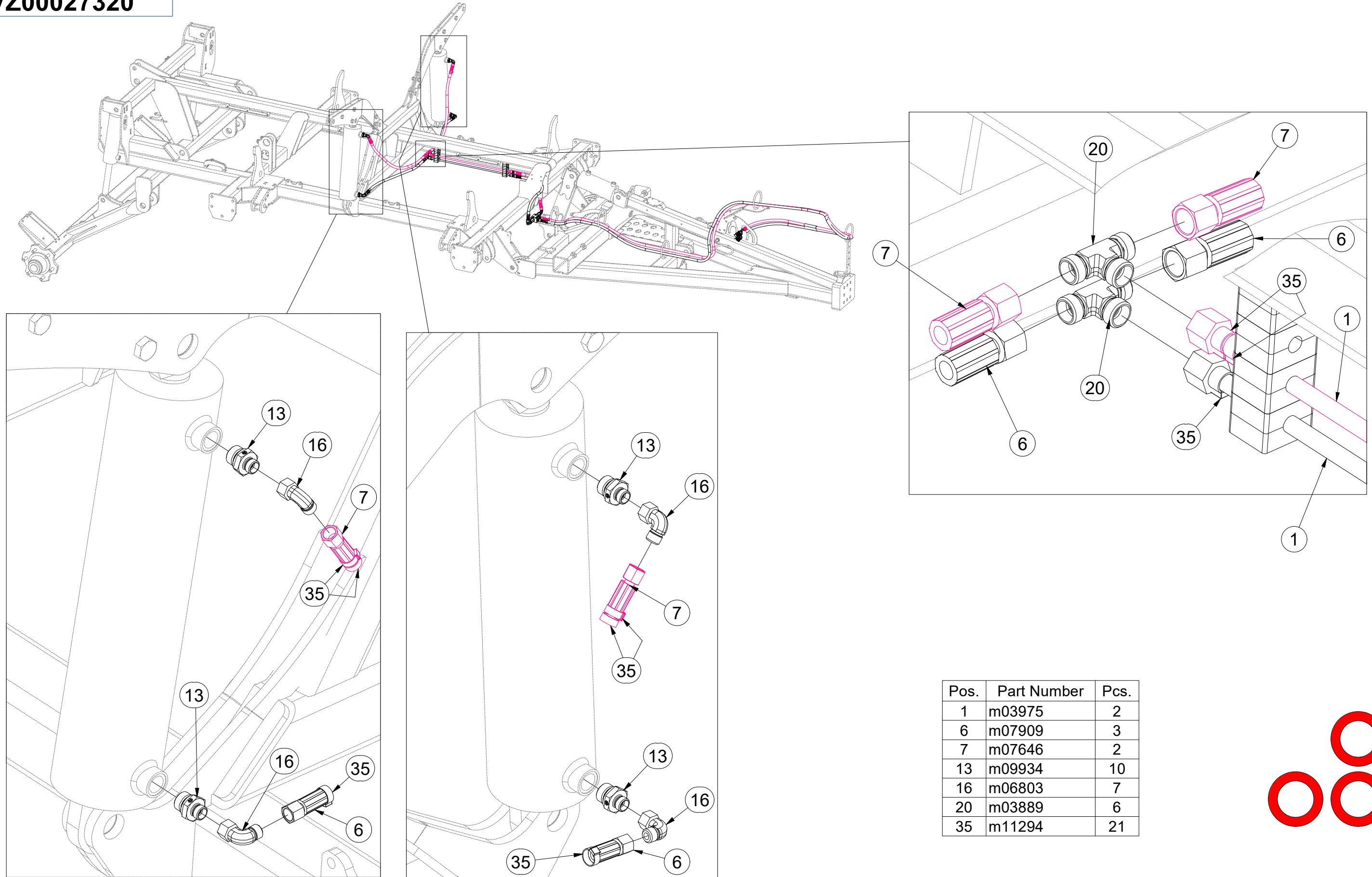



- ⒸZ OJ MONT
- Ⓓ DEICHSEL MONTIERT
- Ⓕ TIMON MONTÉ

- ⒼB MONT DRAWBAR
- ⒽU ДЫШЛО МОНТ.
- ⒽL DYSZEL MONT



**VZ00012188**

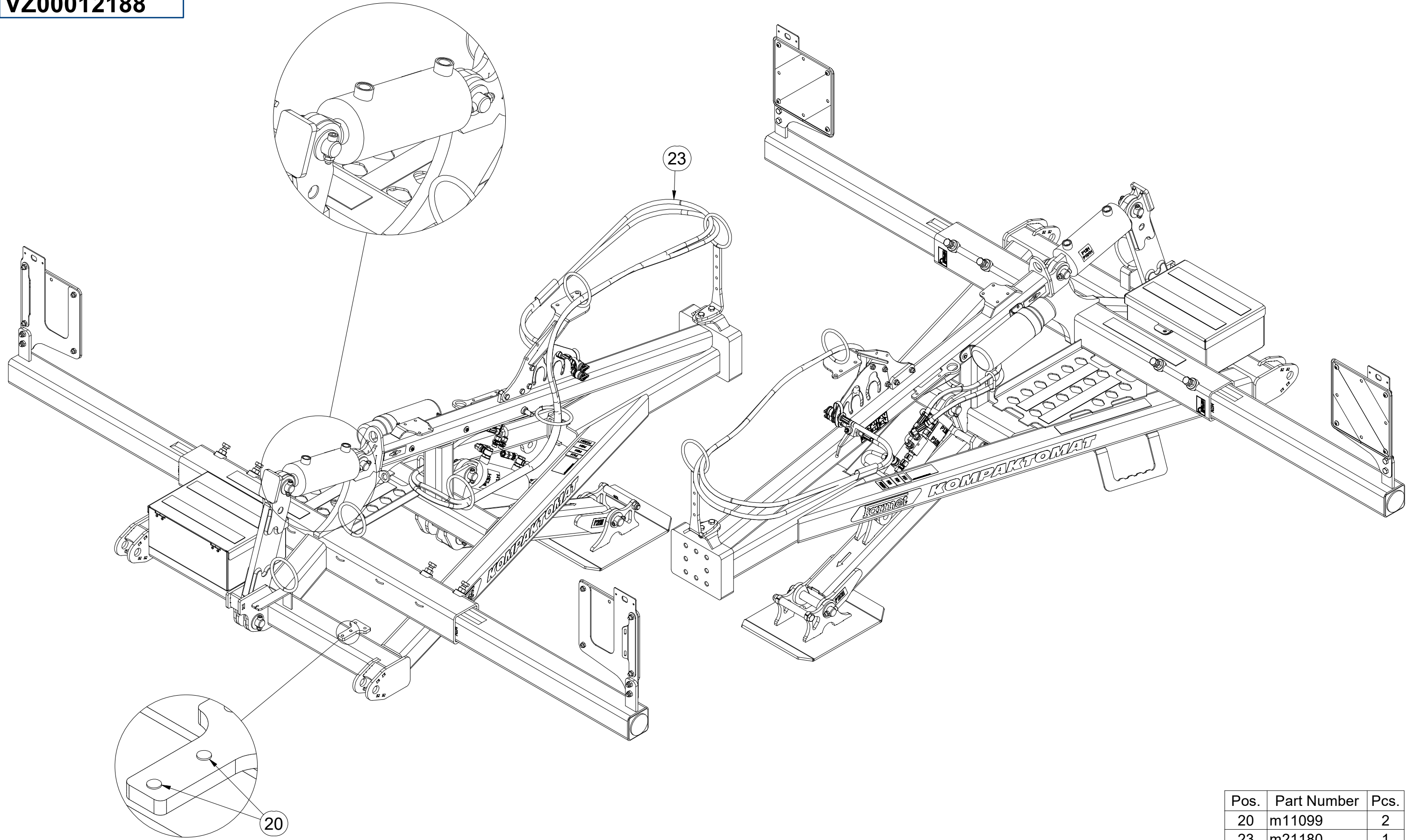

Pos.	Part Number	Pcs.
20	m11099	2
23	m21180	1

Ⓒ OJ MONT

Ⓓ DEICHSEL MONTIERT

Ⓕ TIMON MONTÉ

Ⓖ MONT DRAWBAR

Ⓡ ДЫШЛО МОНТ.

Ⓟ DYSZEL MONT



**VZ00012188**

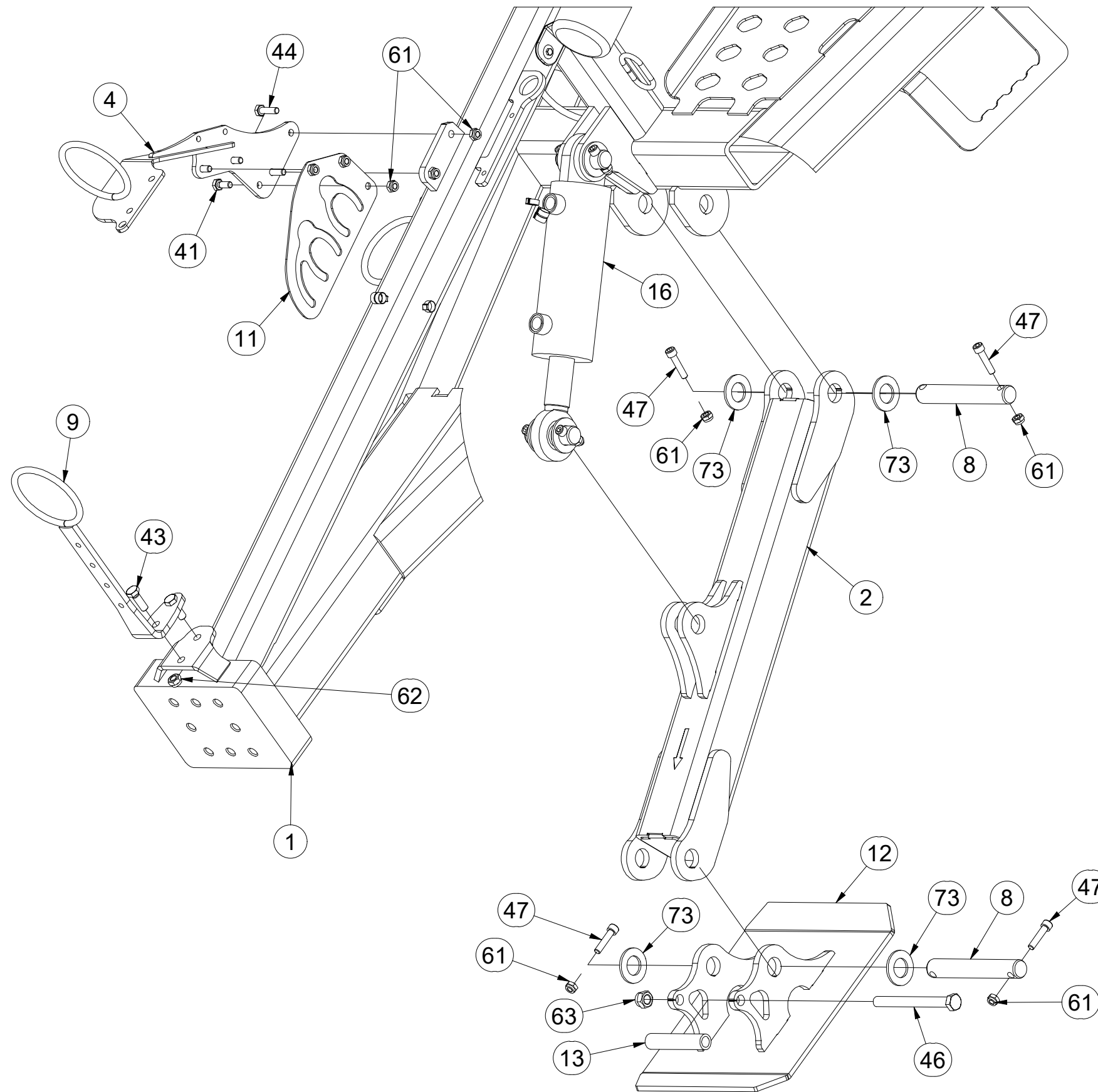

Pos.	Part Number	Pcs.
1	2001126	1
2	3011119	1
4	3012460	1
8	4015702	2
9	4019191	1
11	4020971	1
12	4022481	1
13	4022490	1
16	VZ00024031	1
41	m03681	3
43	m04343	2
44	m04613	2
46	m13041	1
47	m14143	14
61	m03775	19
62	m04301	6
63	m03683	1
73	m14029	14

ⒸZ OJ MONT

Ⓓ DEICHSEL MONTIERT

Ⓕ TIMON MONTÉ

**VZ00012188**

ⒸB MONT DRAWBAR

ⒸR ДЫШЛО МОНТ.

ⒸL DYSZEL MONT

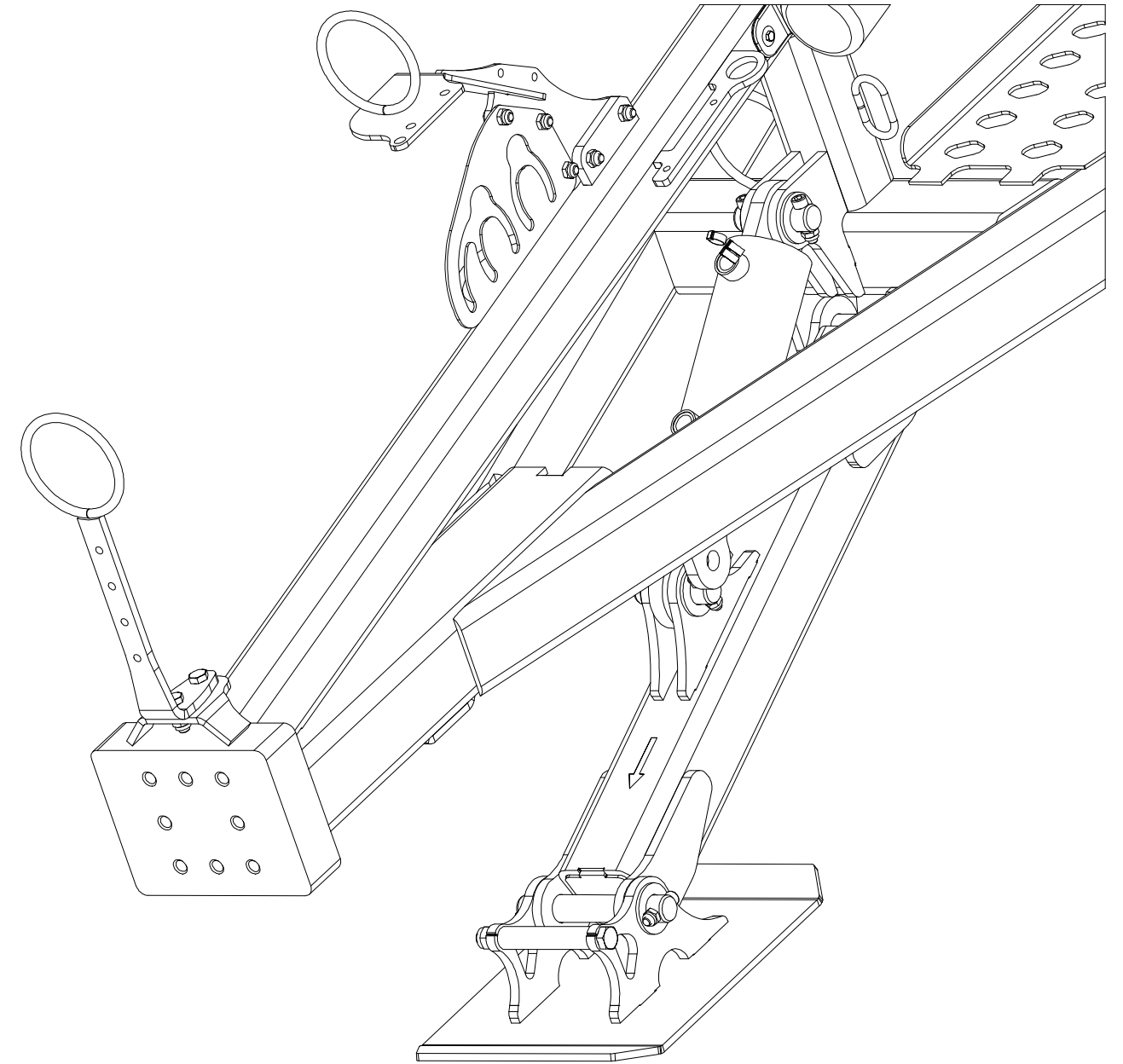
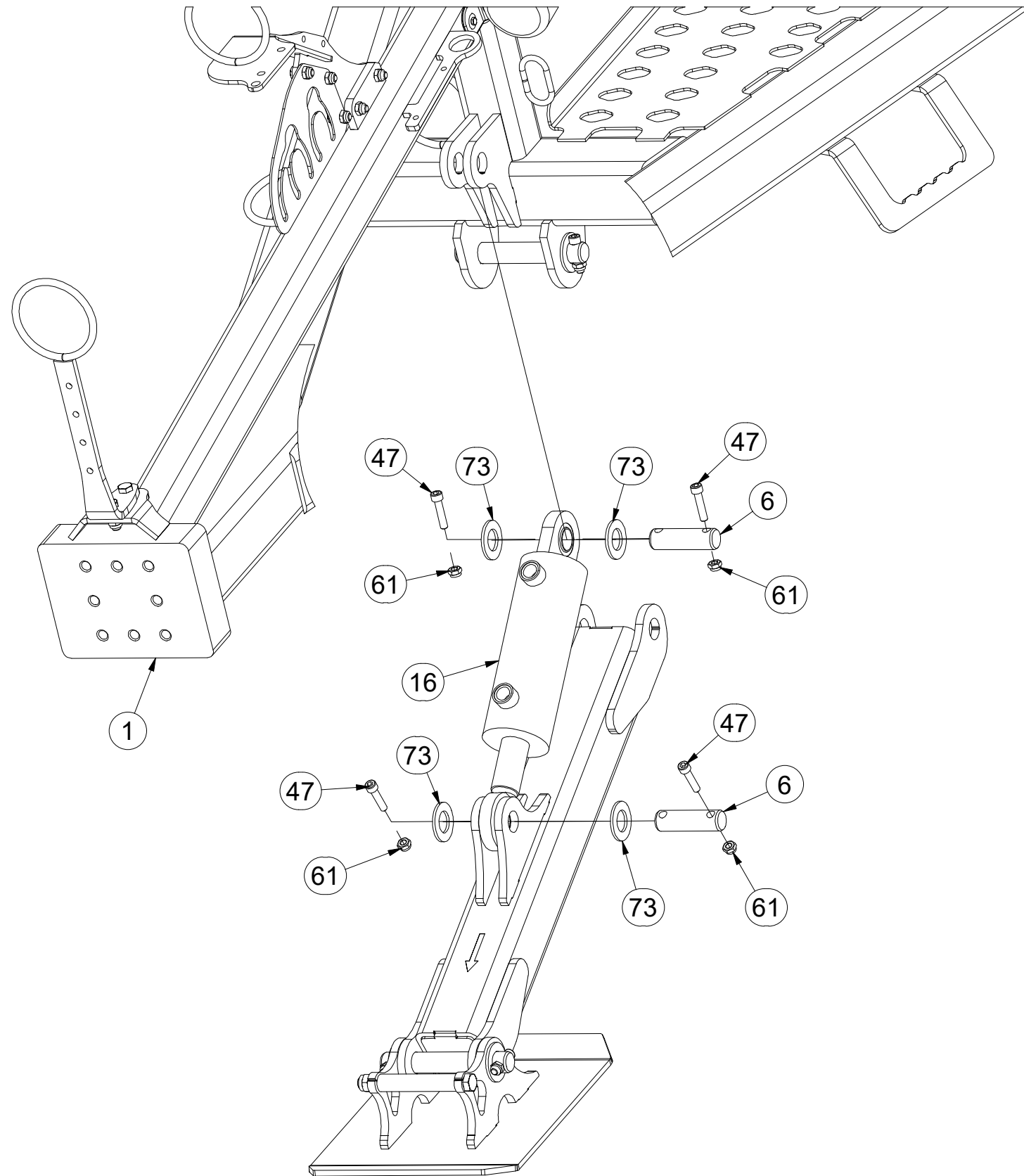

Pos.	Part Number	Pcs.
1	2001126	1
6	4008234	3
16	VZ00024031	1
47	m14143	14
61	m03775	19
73	m14029	14

Ⓒ CZ OJ MONT

Ⓓ DEICHSEL MONTIERT

Ⓕ TIMON MONTÉ

**VZ00012188**

Ⓖ GB MONT DRAWBAR

Ⓡ RU ДЫШЛО МОНТ.

Ⓟ PL DYSZEL MONT

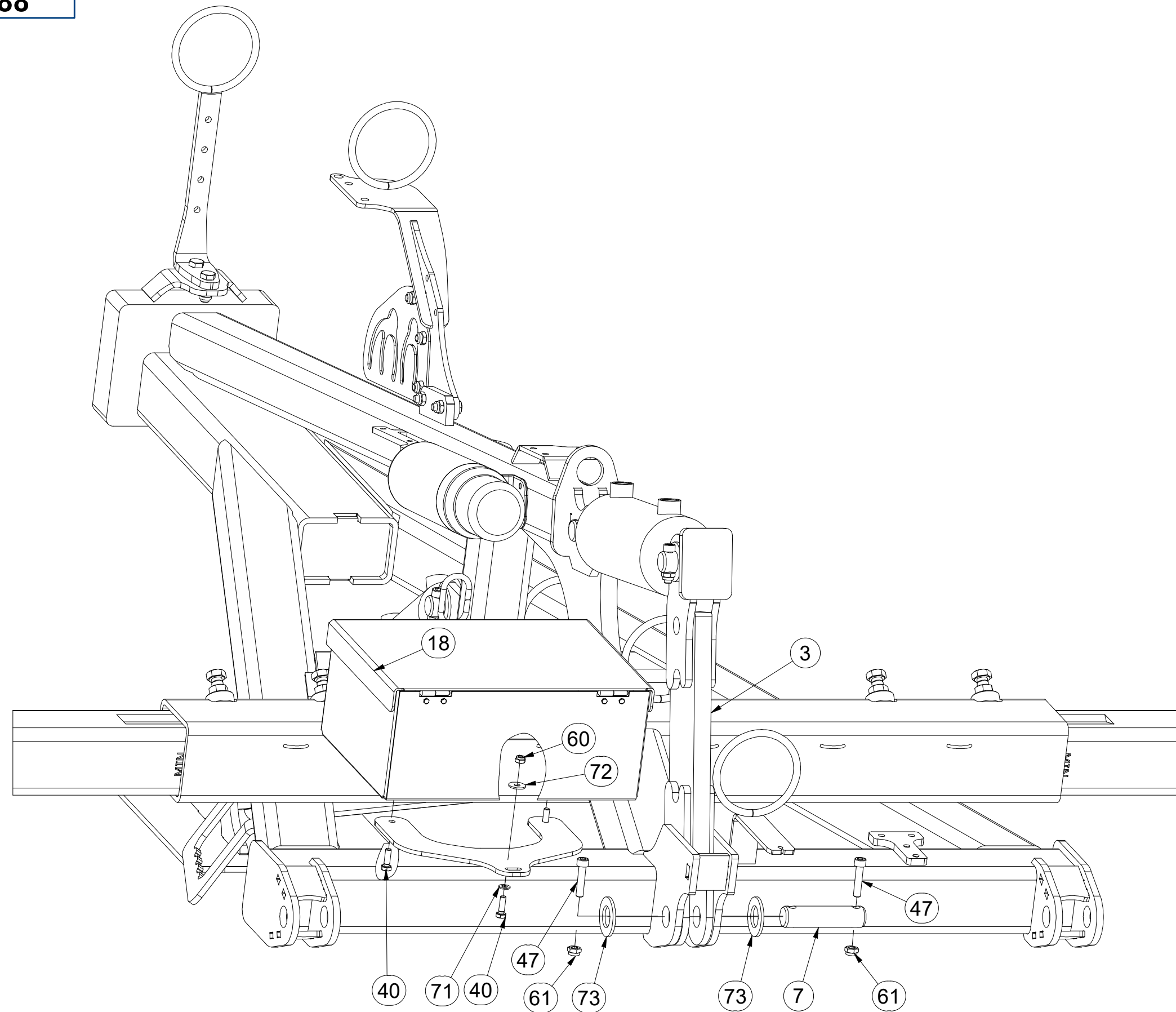

Pos.	Part Number	Pcs.
3	3011506	1
7	4014569	1
18	m12296	1
40	m01092	3
47	m14143	14
60	m04503	3
61	m03775	19
71	m01203	1
72	m07936	3
73	m14029	14

ⒸZ OJ MONT

Ⓓ DEICHSEL MONTIERT

Ⓕ TIMON MONTÉ

ⒸB MONT DRAWBAR

ⒸR ДЫШЛО МОНТ.

ⒸL DYSZEL MONT



**VZ00012188**

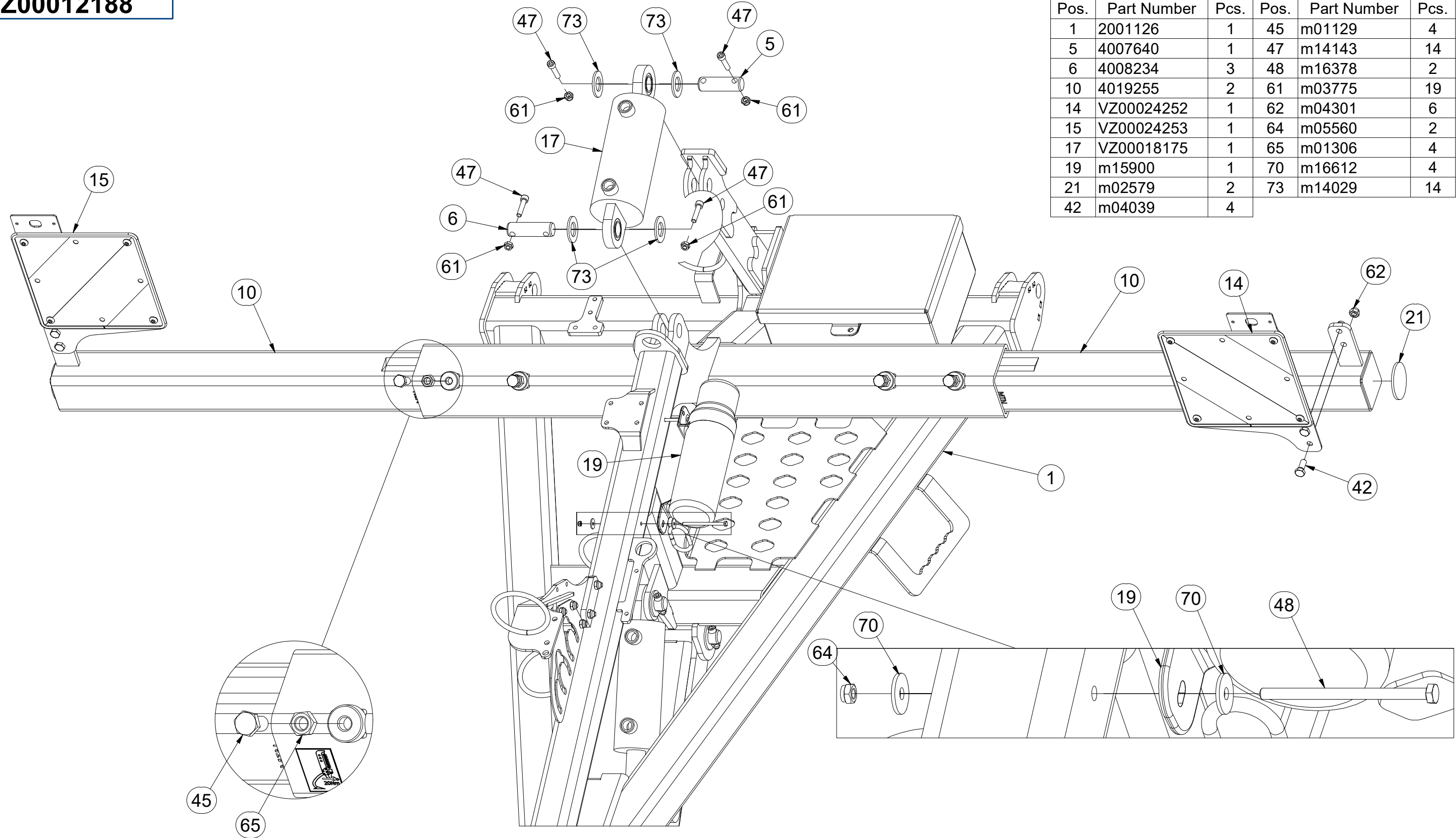

Pos.	Part Number	Pcs.	Pos.	Part Number	Pcs.
1	2001126	1	45	m01129	4
5	4007640	1	47	m14143	14
6	4008234	3	48	m16378	2
10	4019255	2	61	m03775	19
14	VZ00024252	1	62	m04301	6
15	VZ00024253	1	64	m05560	2
17	VZ00018175	1	65	m01306	4
19	m15900	1	70	m16612	4
21	m02579	2	73	m14029	14
42	m04039	4			

ⒸZ OJ MONT

Ⓓ DEICHSEL MONTIERT

Ⓕ TIMON MONTÉ

**m21180**

ⒼB MONT DRAWBAR

ⒺD ДЫШЛО МОНТ.

ⒽL DYSZEL MONT

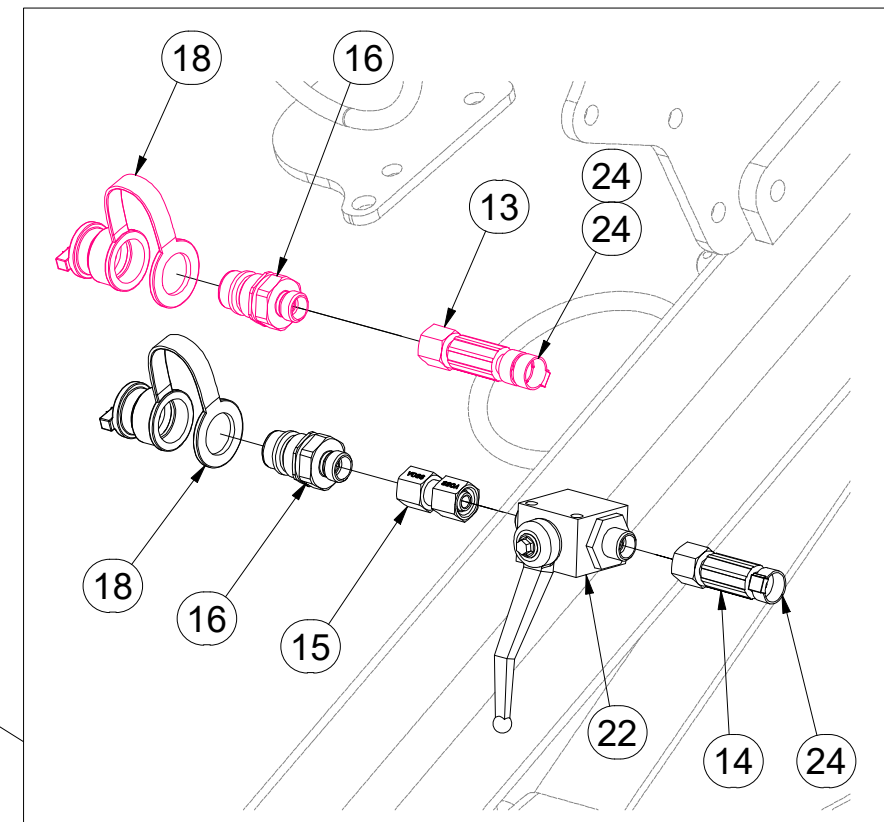
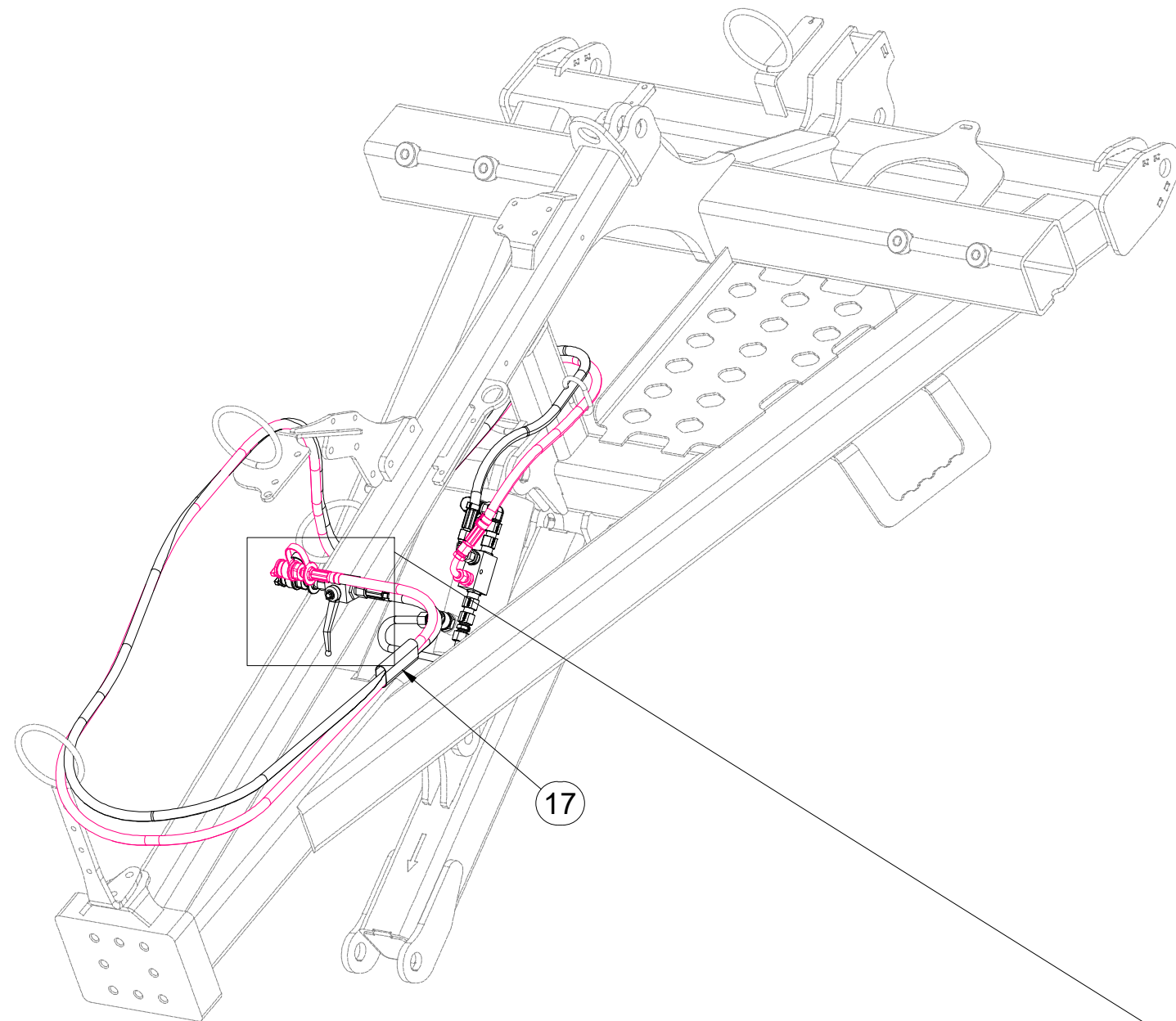

Pos.	Part Number	Pcs.
13	m12025	1
14	m16372	1
15	m22305	1
16	m03849	2
17	m11183	1
18	m04622	2
22	m04623	1
24	m05566	6

Ⓒ CZ OJ MONT

Ⓓ DEICHSEL MONTIERT

Ⓕ TIMON MONTÉ

**m21180**

Ⓖ GB MONT DRAWBAR

Ⓡ RU ДЫШЛО МОНТ.

Ⓟ PL DYSZEL MONT

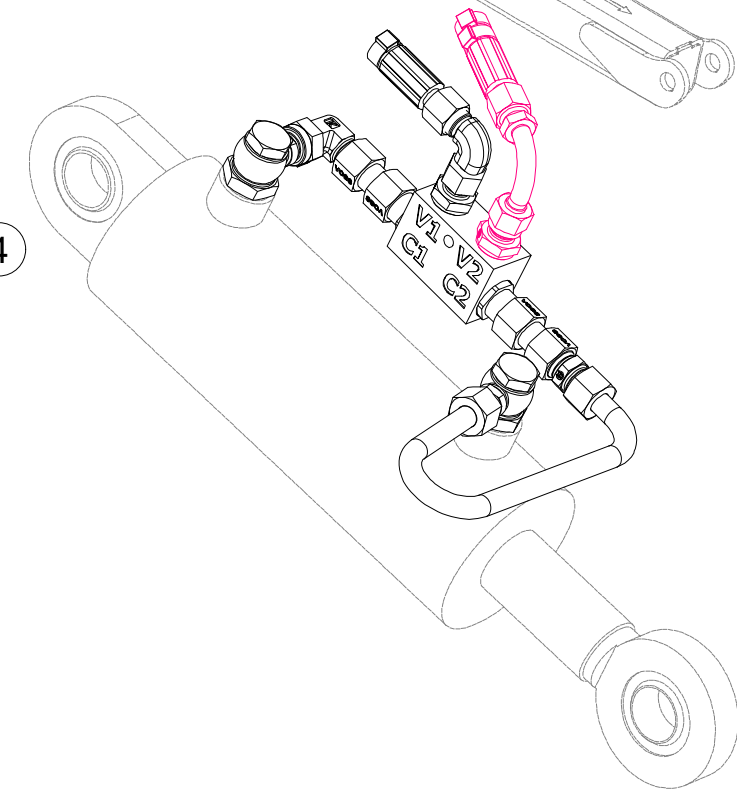
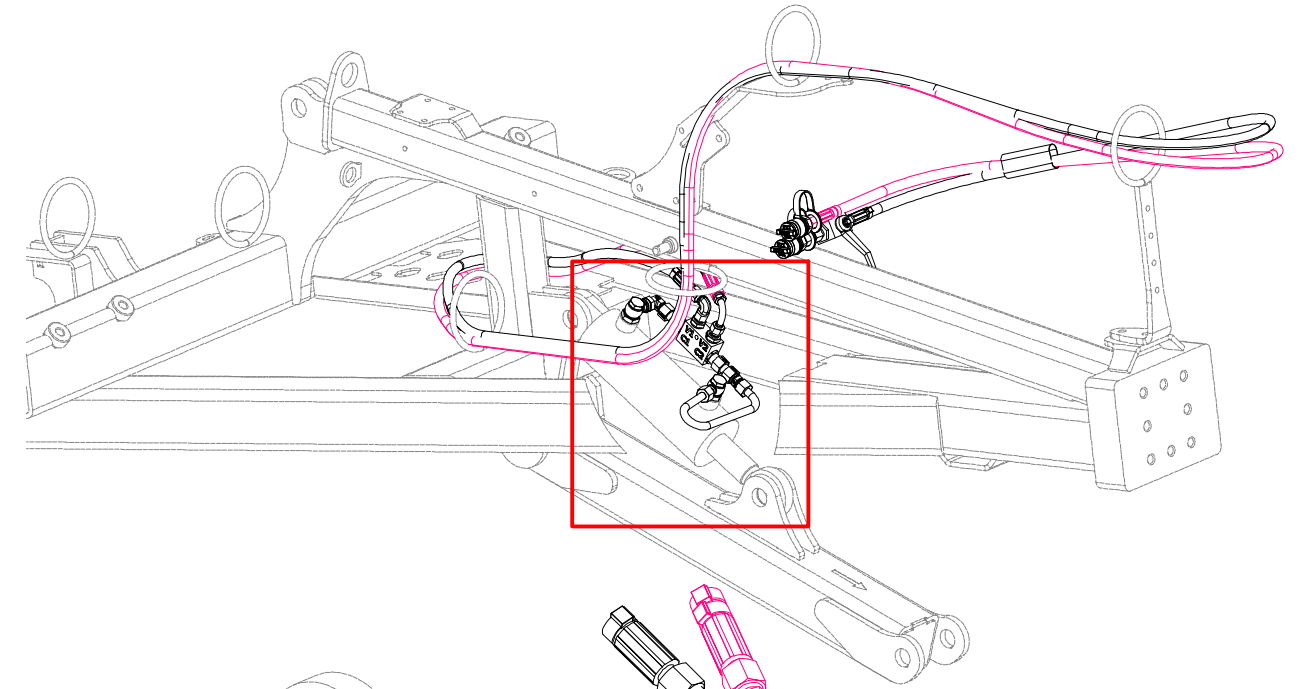
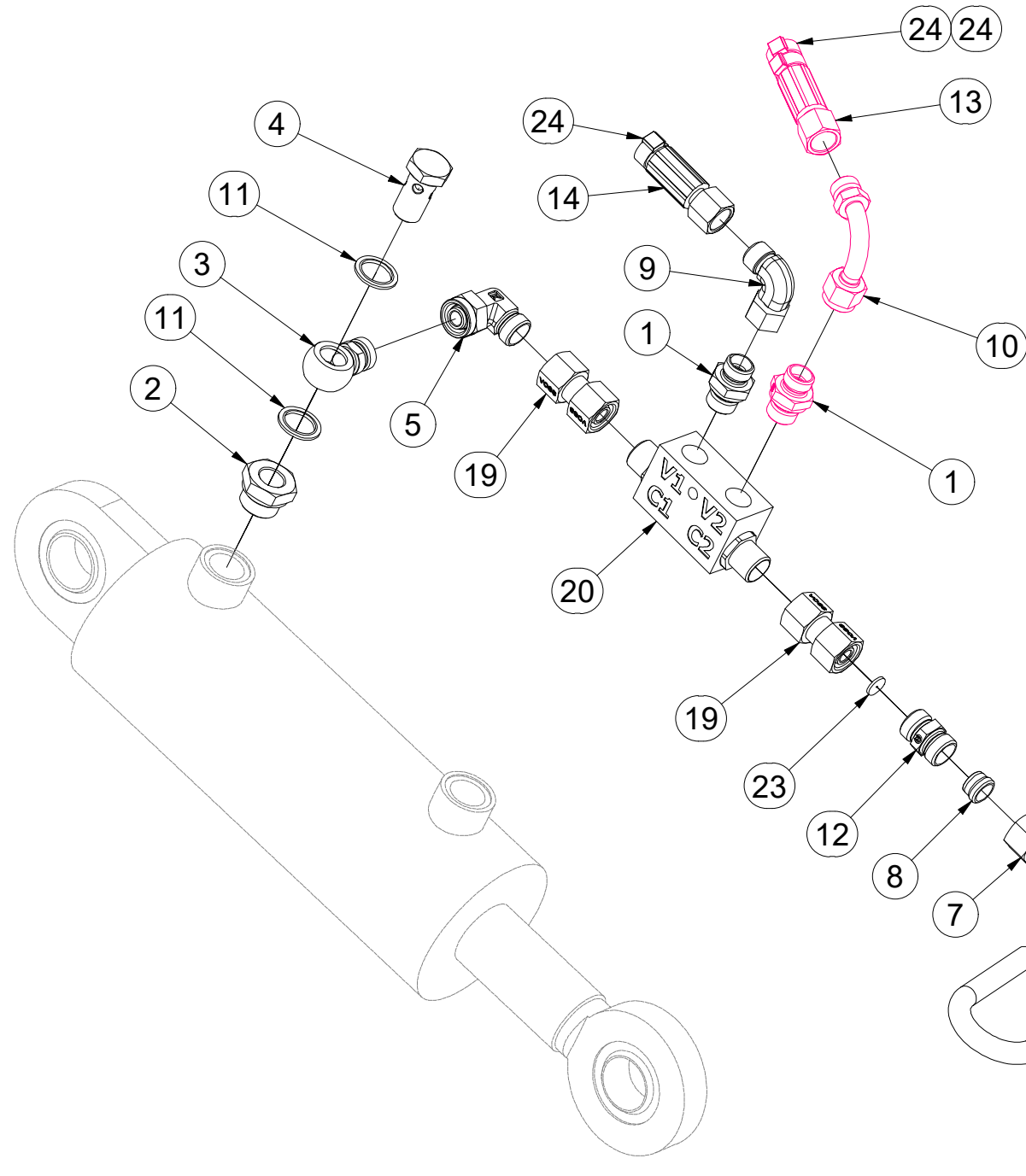

Pos.	Part Number	Pcs.	Pos.	Part Number	Pcs.
1	m06528	2	10	m04024	1
2	m08462	2	11	m12442	4
3	m08461	2	12	m16910	1
4	m08460	2	13	m12025	1
5	m07654	1	14	m16372	1
6	VZ00022659	1	19	m22306	2
7	m08861	2	20	m08083	1
8	m08862	2	23	m10774	2
9	m06803	1	24	m05566	6

☉ SAMOLEPKY STROJE

☉ AUFKLEBER MASCHINEN

☉ VOITURE MACHINES

☉ STICKERS MACHINES

☉ СТИКЕРЫ МАШИНЫ

☉ NAKLEJKI MASZYNY



**m19075**

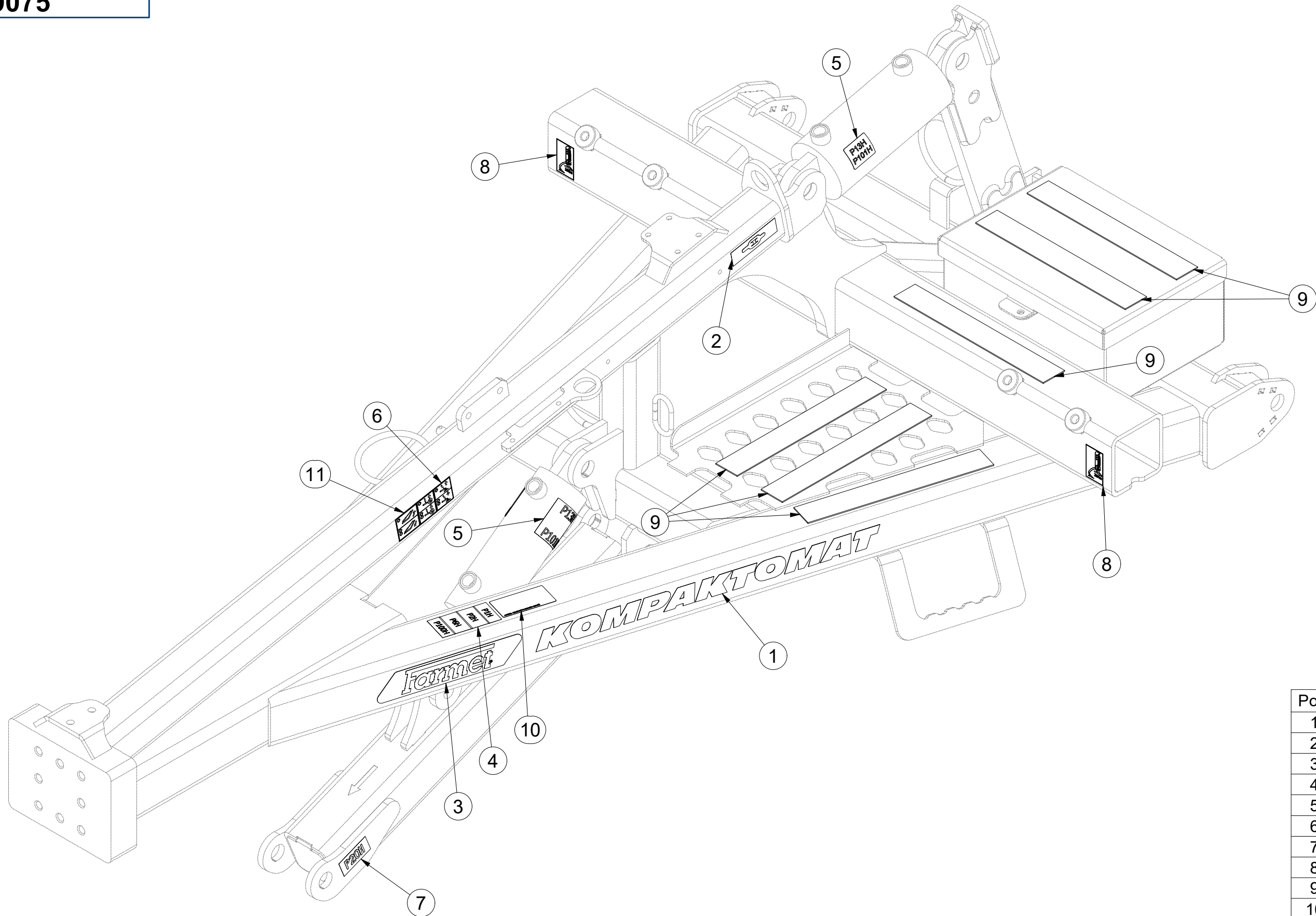

Pos.	Part Number	Pcs.
1	m07688	2
2	m03316	2
3	m13116	2
4	m11295	2
5	m11299	3
6	m17224	1
7	m04368	2
8	m10180	2
9	m11146	6
10	m13708	2
11	m11291	1



☉ SAMOLEPKY STROJE

☉ AUFKLEBER MASCHINEN

☉ VOITURE MACHINES

☉ STICKERS MACHINES

☉ СТИКЕРЫ МАШИНЫ

☉ NAKLEJKI MASZYNY



**m19075**

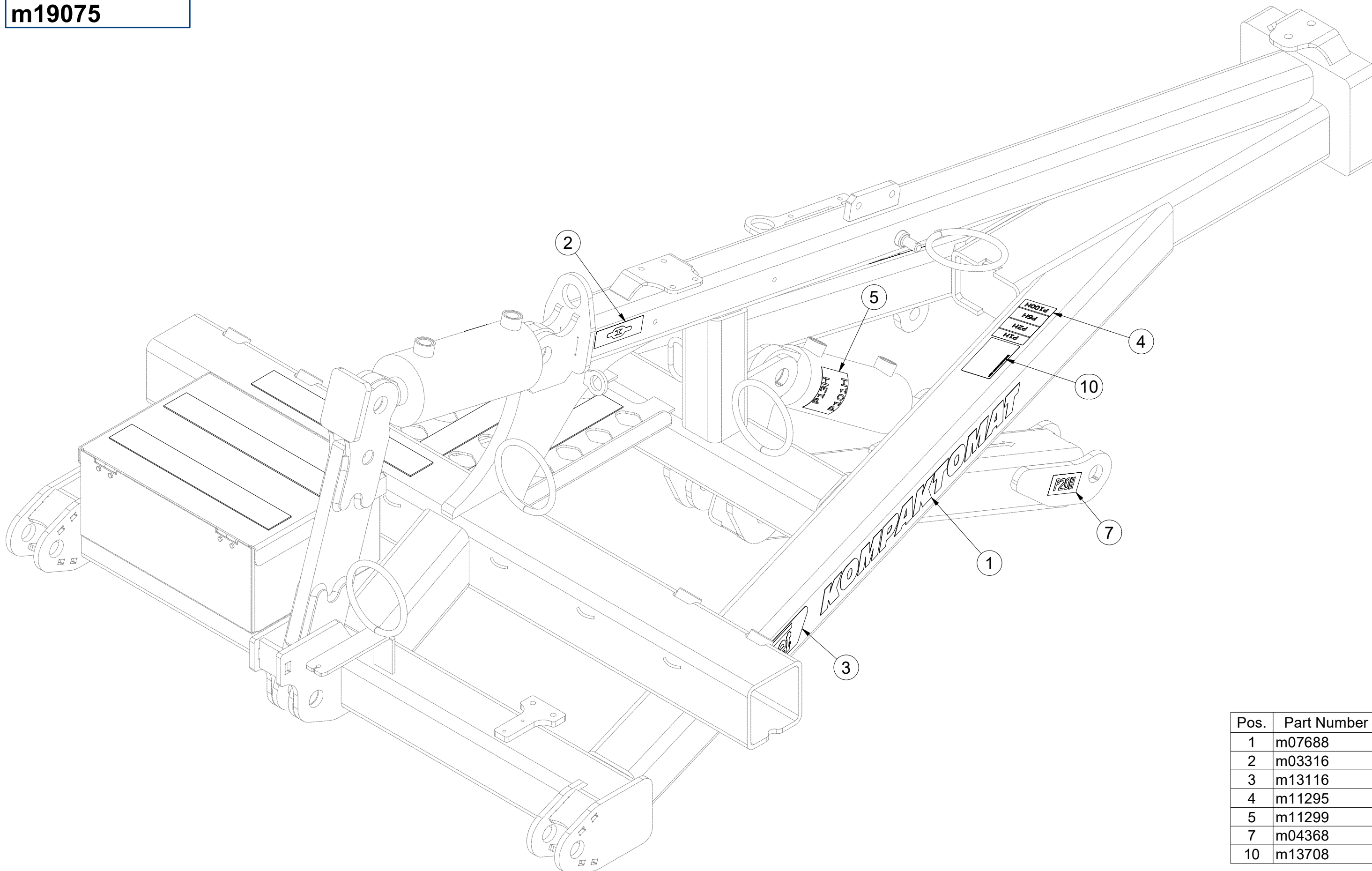

Pos.	Part Number	Pcs.
1	m07688	2
2	m03316	2
3	m13116	2
4	m11295	2
5	m11299	3
7	m04368	2
10	m13708	2

Ⓒ SPOJOVACÍ TÁHLO  
Ⓓ VERBINDUNGSSTANGE  
Ⓕ TIGE DE RACCORDEMENT

Ⓖ CONNECTING ROD  
Ⓡ СОЕДИНИТЕЛЬНАЯ ТЯГА  
Ⓟ KORBOWÓD



**4003966**

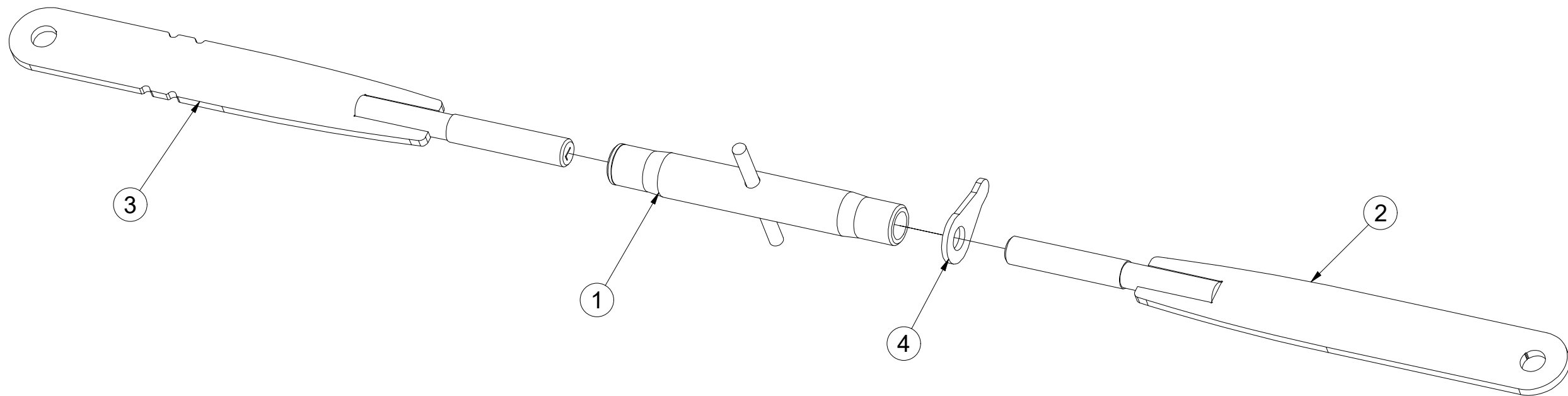
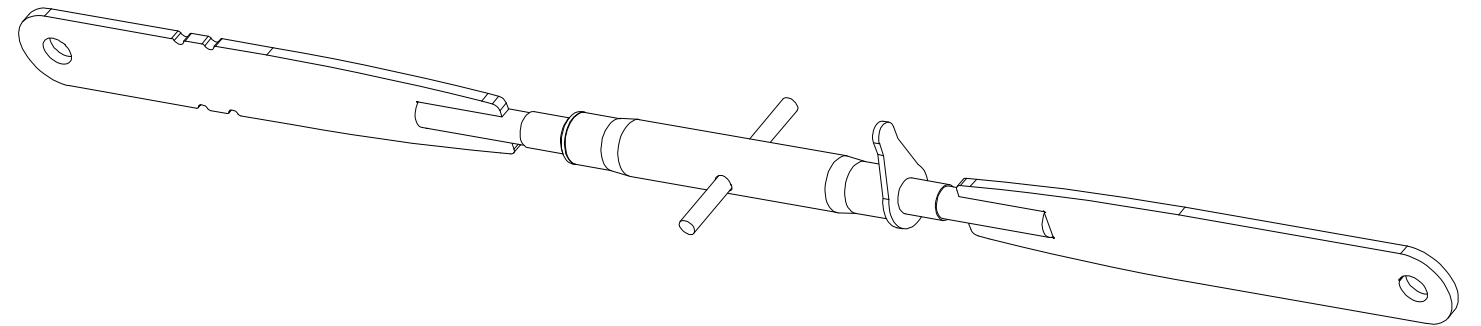

Pos.	Part Number	Pcs.
1	m08880	1
2	4023421	1
3	4023423	1
4	m08881	1

Ⓒ SADA DORAZŮ  
Ⓓ ANSCHLAGSATZ  
Ⓕ KIT DE BUTÉES

**4022352**

Ⓖ SET OF BAR STOPS  
Ⓡ КОМПЛЕКТ УПОРОВ  
Ⓢ ZESTAW DOCISKÓW

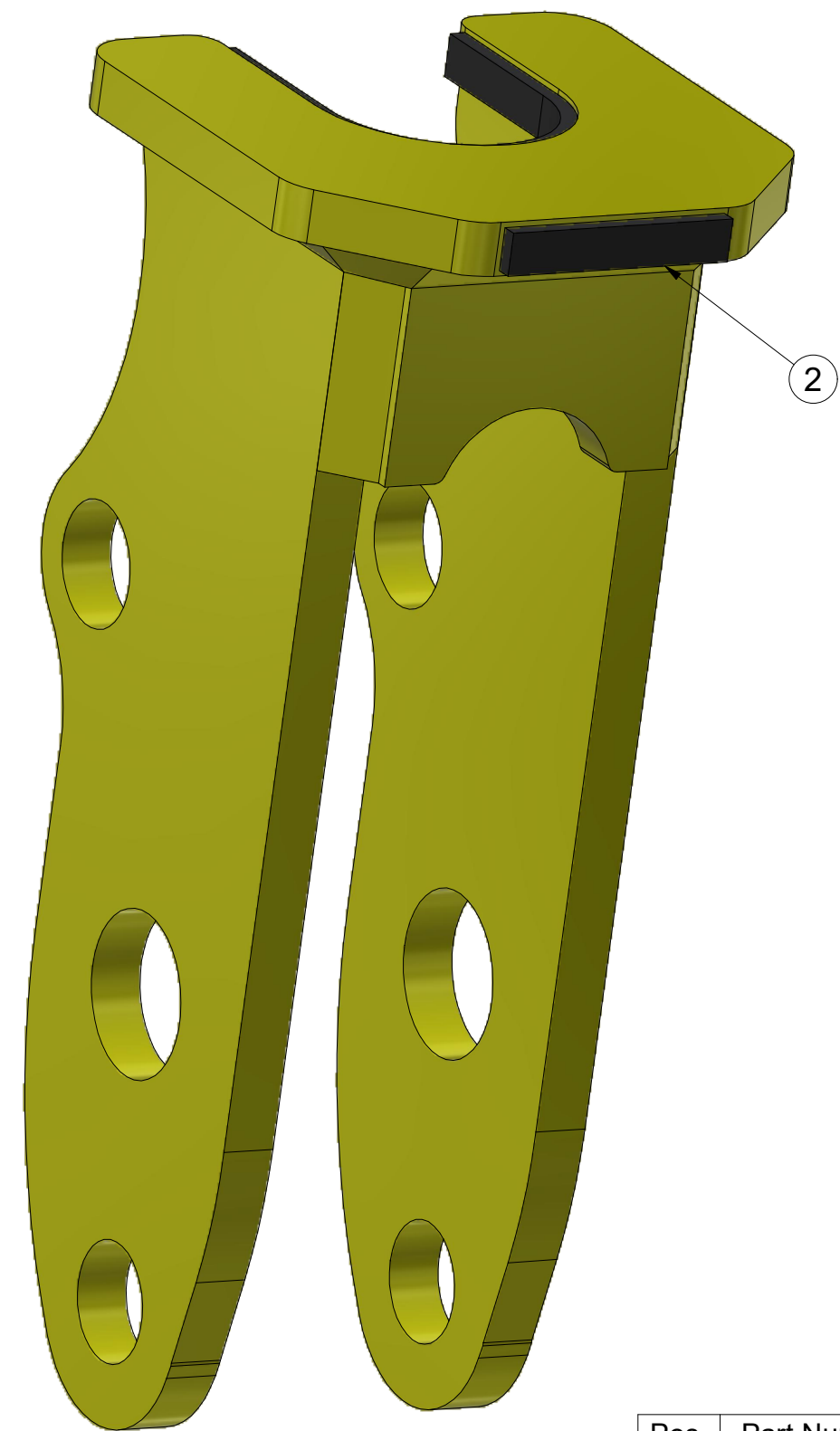
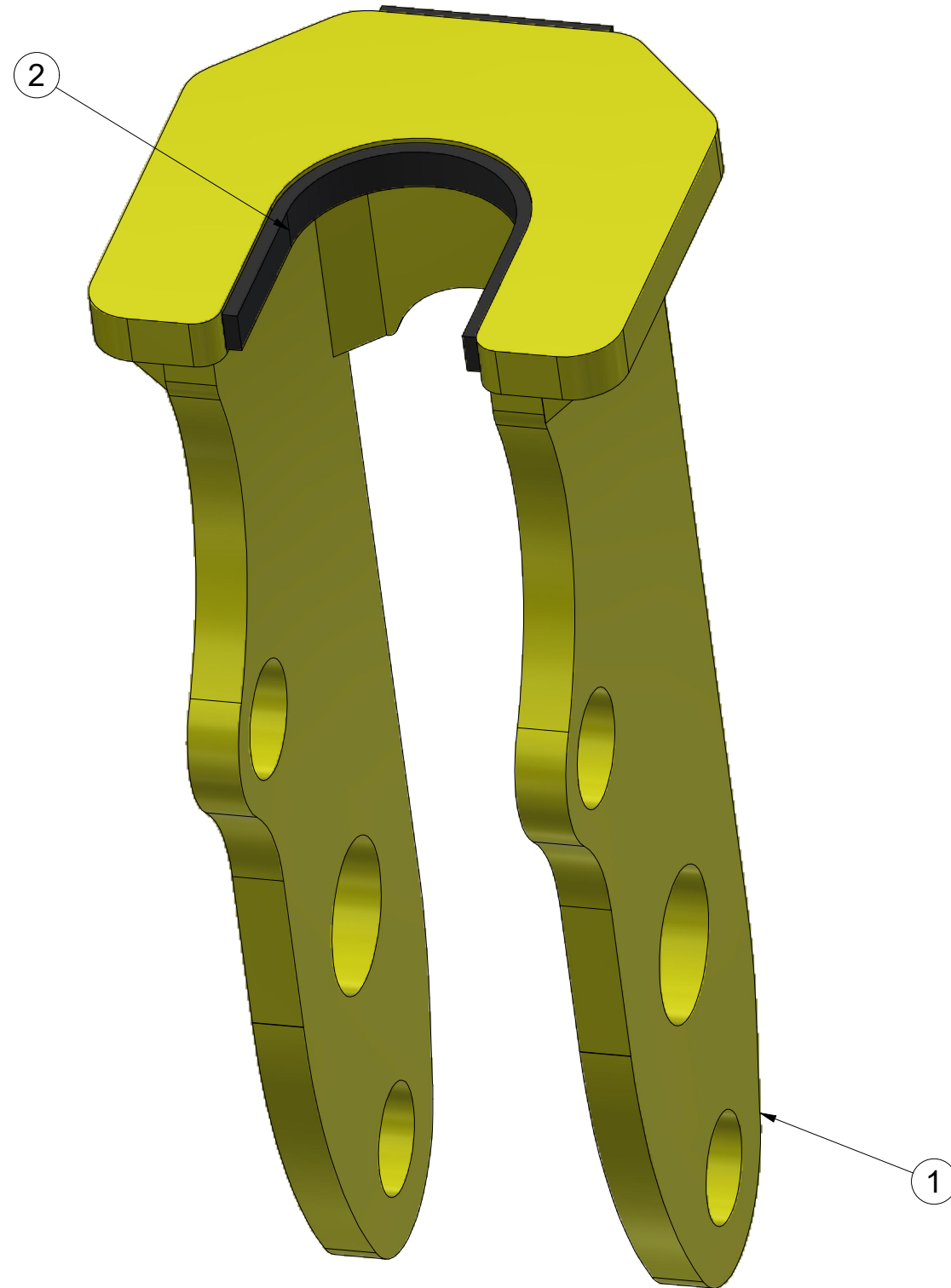

Pos.	Part Number	Pcs.
1	3011045	1
2	m09566	0,225 m

ⒸZ TÁHLO SKLÁPĚNÍ

Ⓓ ZUGSTANGE ZUR KIPPUNG

Ⓕ TIGES DE L'ESSIEU

**4005363**

ⒼB TILTING PULL ROD

ⒺU ТЯГИ ТРАНСПОРТНОЙ ОСИ

ⒽL SPRZĘGI OSI

**Farmet**

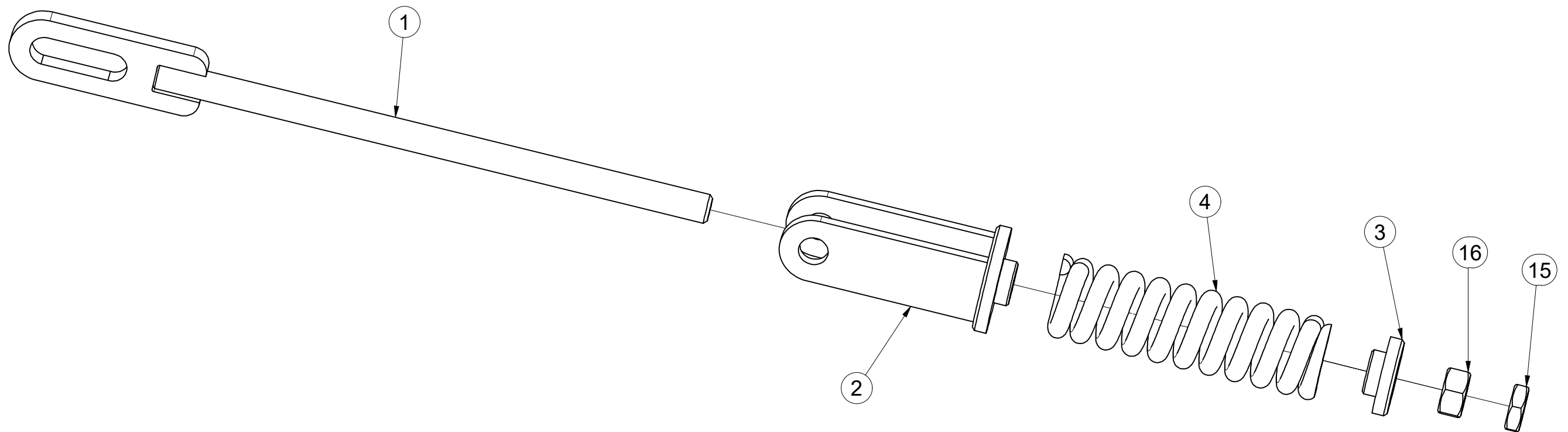
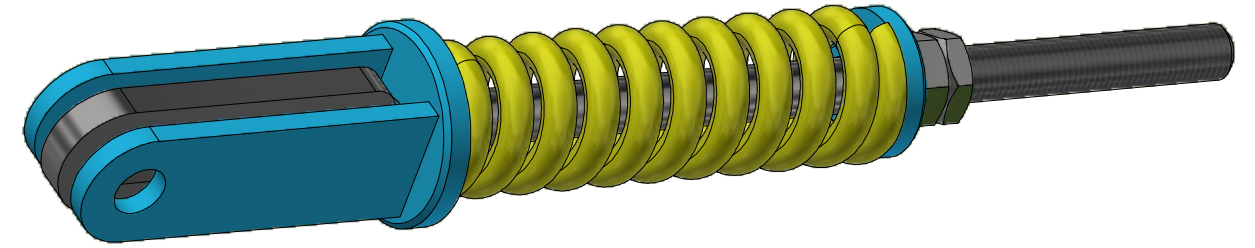

Pos.	Part Number	Pcs.
1	4005358	1
2	4005361	1
3	4000023	1
4	m06482	1
15	m04043	1
16	m01309	1

Ⓒ SADA TAŽNÉHO OKA

Ⓓ ZUGÖSESATZ

Ⓕ KIT DE L'ŒILLET DE TRACTION

Ⓖ TOWING LUG SET

Ⓡ КОМПЛЕКТ ТЯГОВОГО ДЫШЛА

Ⓟ ZESTAW UCHA HOLOWNICZEGO



**4013529**

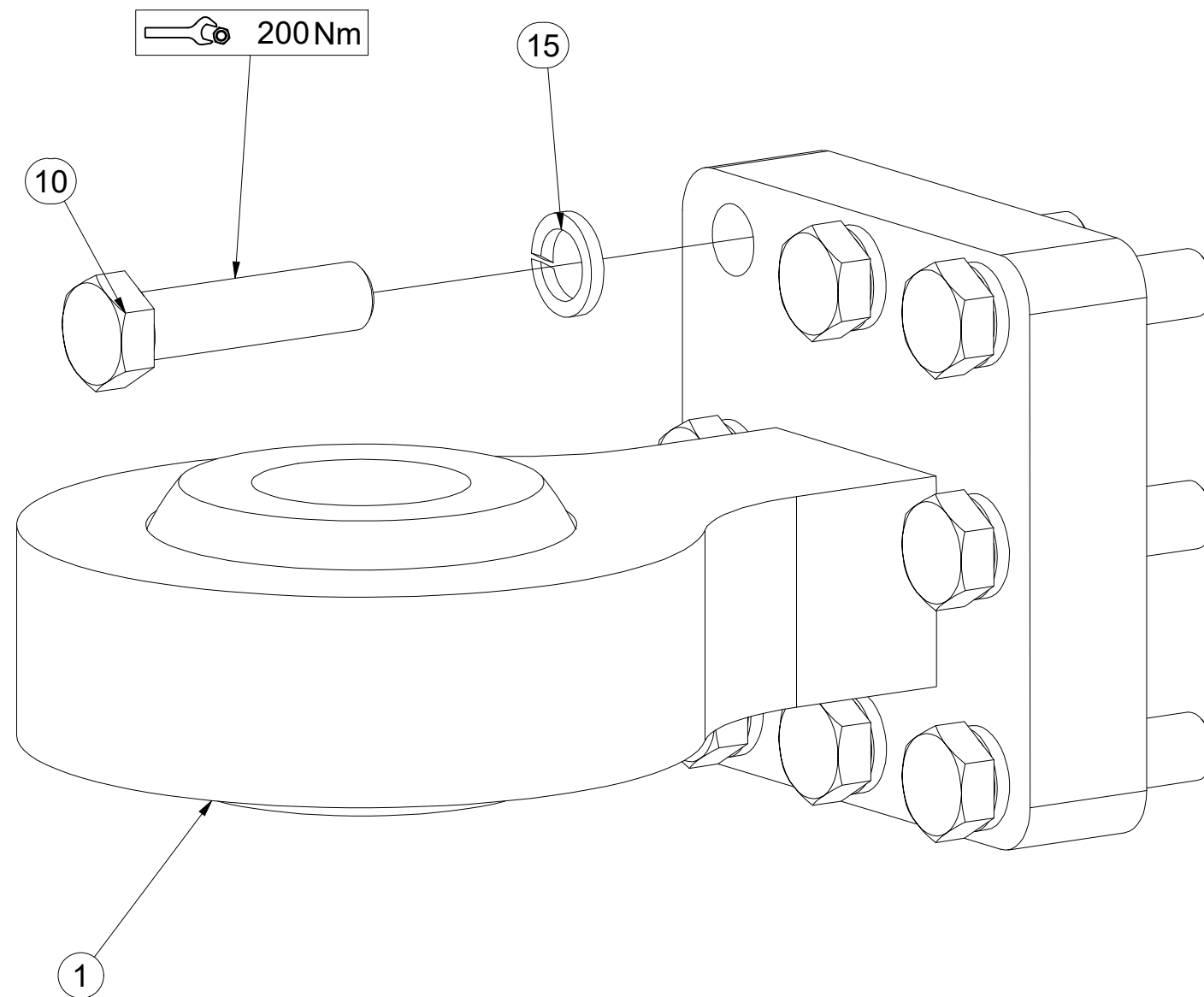

Pos.	Part Number	Pcs.
1	m13263	1
10	m21355	8
15	m02157	8

- ⒸZ TERČ PŘEDNÍ LEVÝ
- Ⓓ SCHILD, VORDERES, LINKES
- Ⓕ CIBLE AVANT GAUCHE

- ⒸB LEFT FRONT DISC
- ⒹU ЩИТОК ПЕРЕДНИЙ ЛЕВЫЙ
- ⒹL TARCZA PRZEDNIA LEWA



**VZ00024252**

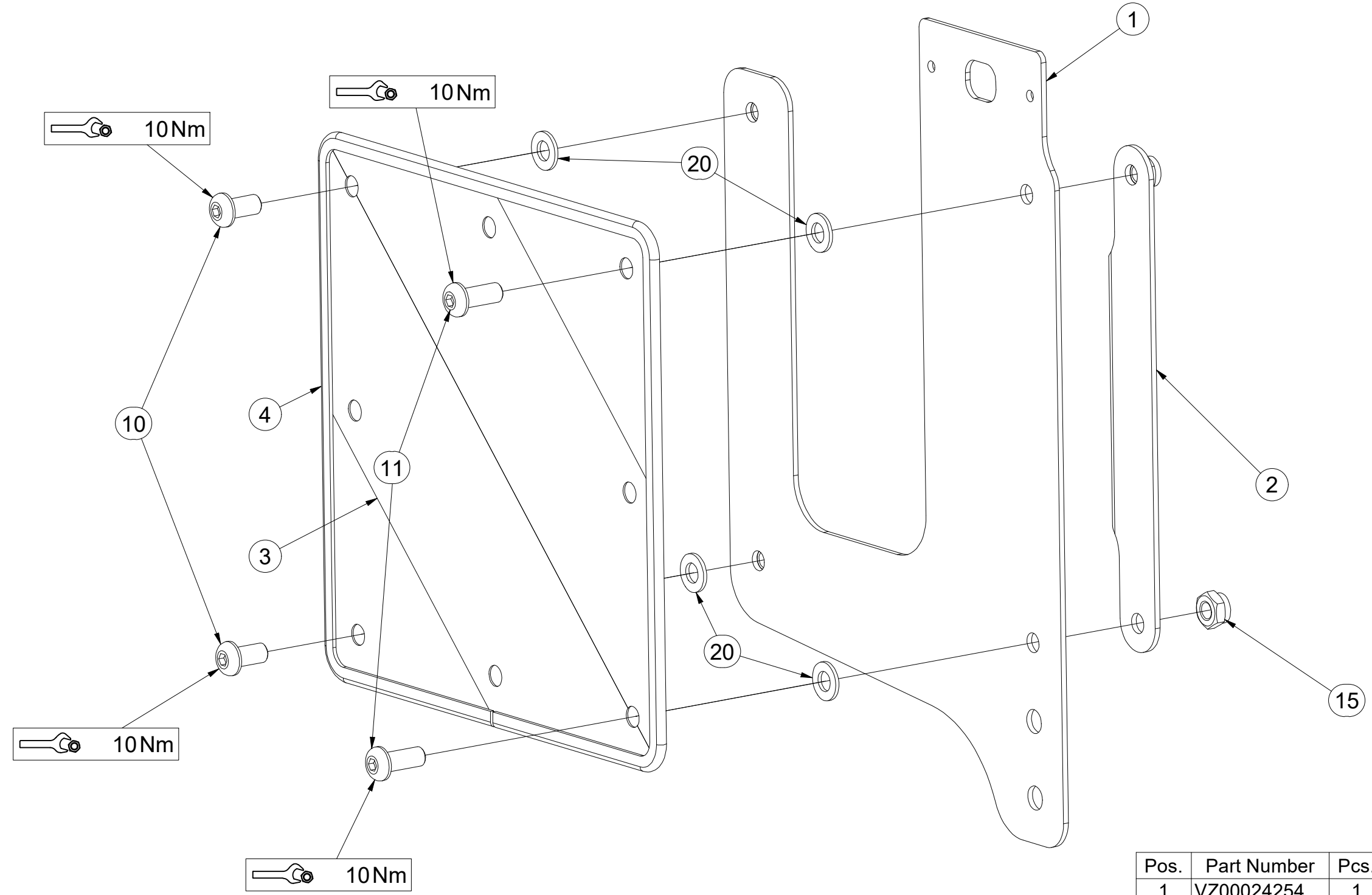

Pos.	Part Number	Pcs.
1	VZ00024254	1
2	VZ00024261	1
3	m18855	1
4	9005707	1
10	m16637	2
11	m16688	2
15	m03775	4
20	m01209	4

ⒸZ TERČ PŘEDNÍ PRAVÝ

Ⓓ SCHILD, VORDERES, RECHTES

Ⓕ CIBLE AVANT DROITE

**VZ00024253**

ⒸB RIGHT FRONT DISC

ⒺЩИТОК ПЕРЕДНИЙ ПРАВЫЙ

ⒼL TARCZA PRZEDNIA PRAWA

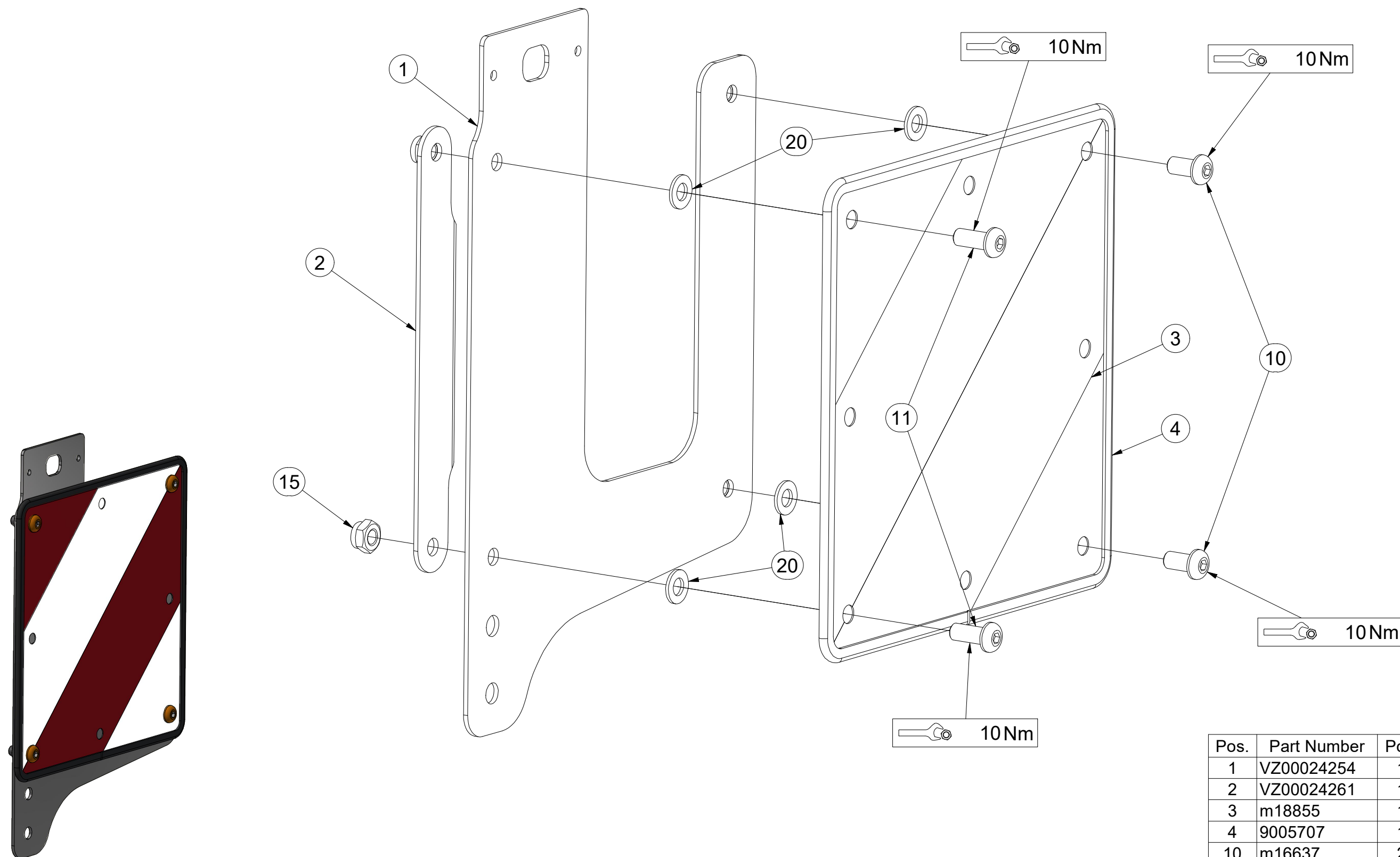

Pos.	Part Number	Pcs.
1	VZ00024254	1
2	VZ00024261	1
3	m18855	1
4	9005707	1
10	m16637	2
11	m16688	2
15	m03775	4
20	m01209	4

Ⓒ SADA KYPŘIČŮ STOP

Ⓓ SPURENLOCKERERSATZ

Ⓕ KIT DE CULTIVATEURS DE TRACES

**3005535**

Ⓖ SET OF TRACK CULTIVATORS

Ⓡ КОМПЛЕКТ РЫХЛИТЕЛЕЙ КОЛЕИ

Ⓟ ZESTAW SPULCHNIACZY ŚLADÓW

**Farmet**

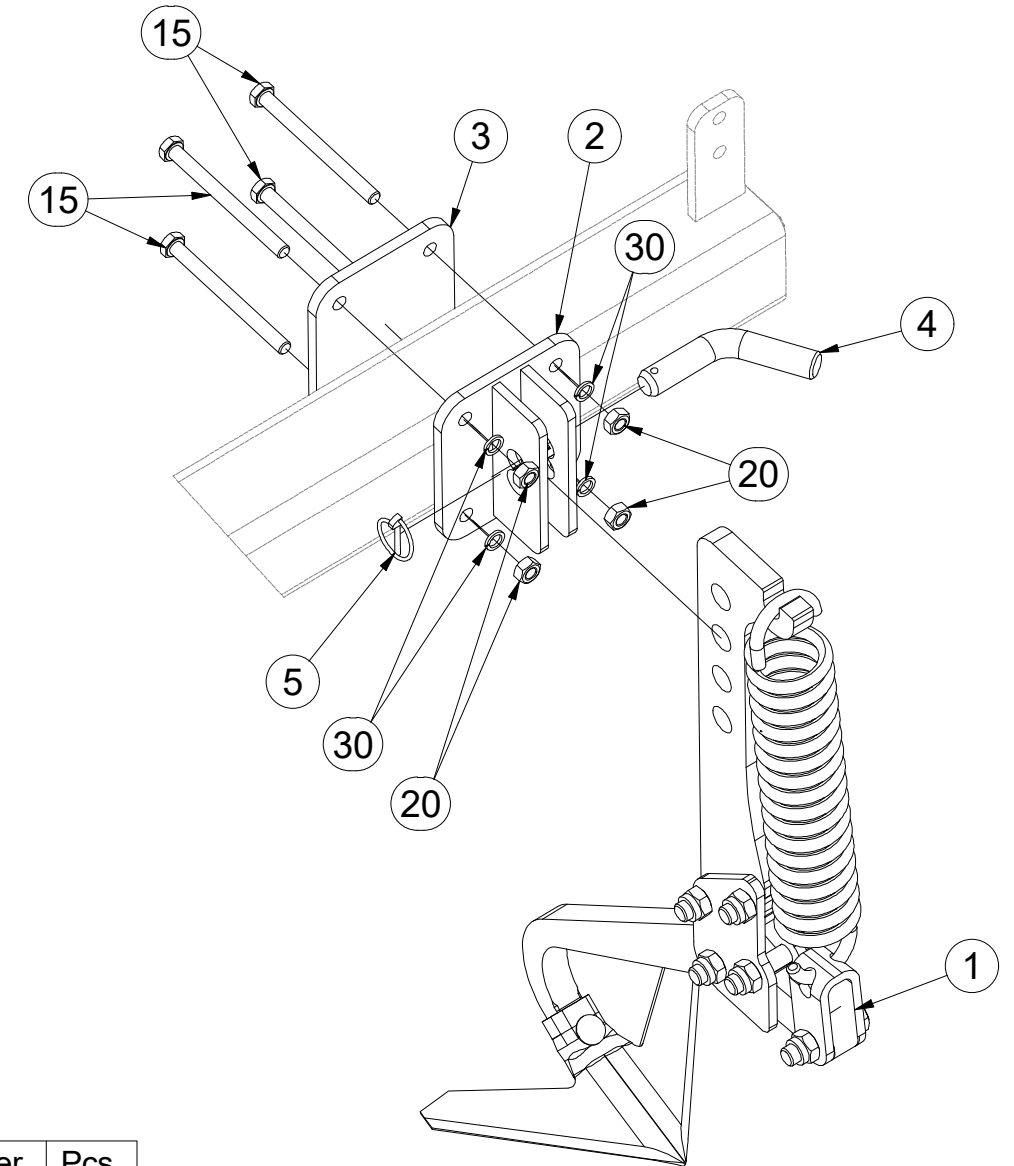
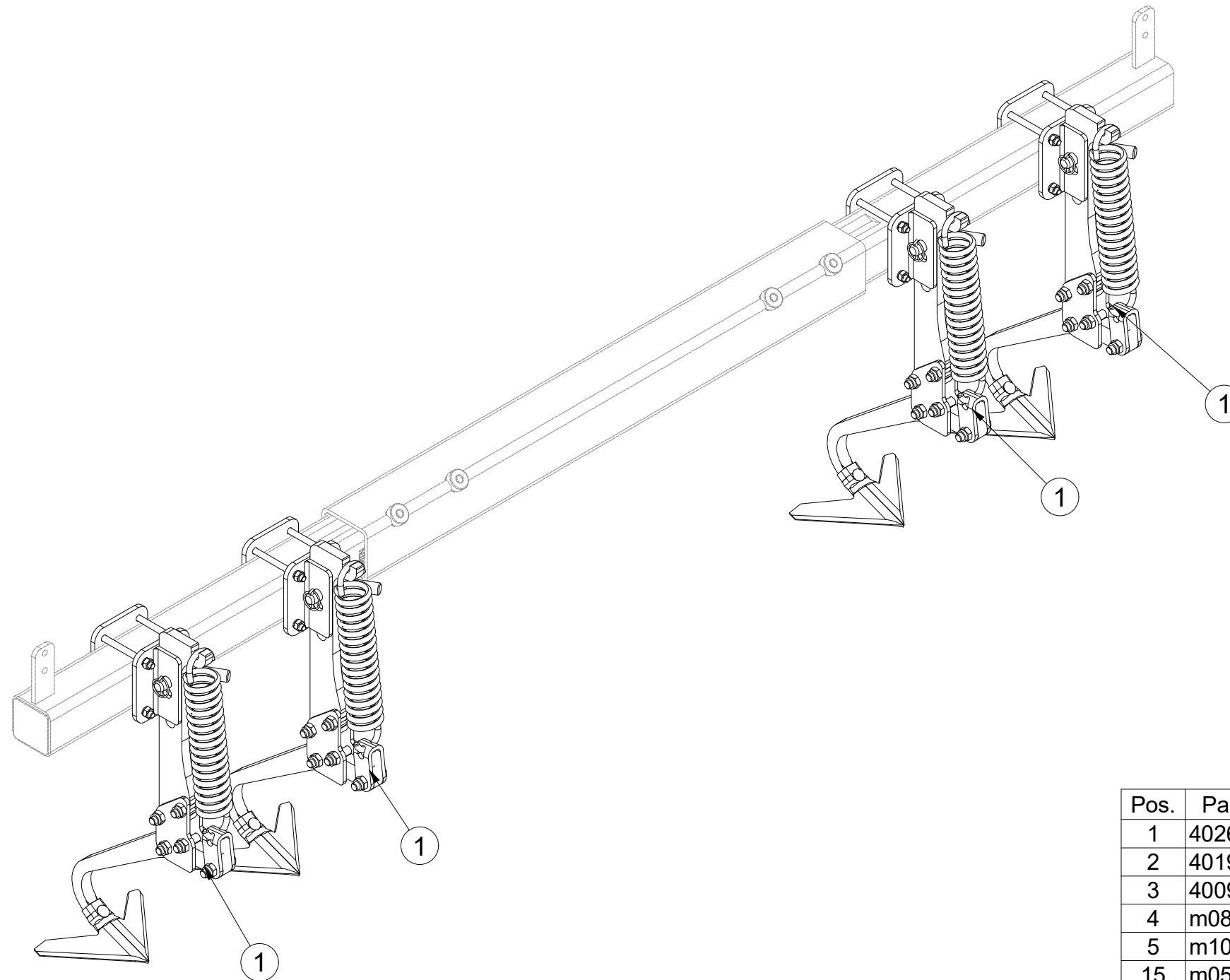

Pos.	Part Number	Pcs.
1	4026045	4
2	4019042	4
3	4009468	4
4	m08885	4
5	m10454	4
15	m05946	16
20	m01305	16
30	m03988	16



Ⓒ KYPŘIČ STOP

Ⓓ SPURENLOCKERER

Ⓕ CULTIVATEUR DES TRACES

Ⓖ TRACK CULTIVATOR

Ⓡ РЫХЛИТЕЛЬ КОЛЕИ

Ⓟ SPULCHNIARKA STÓP



**4026045**

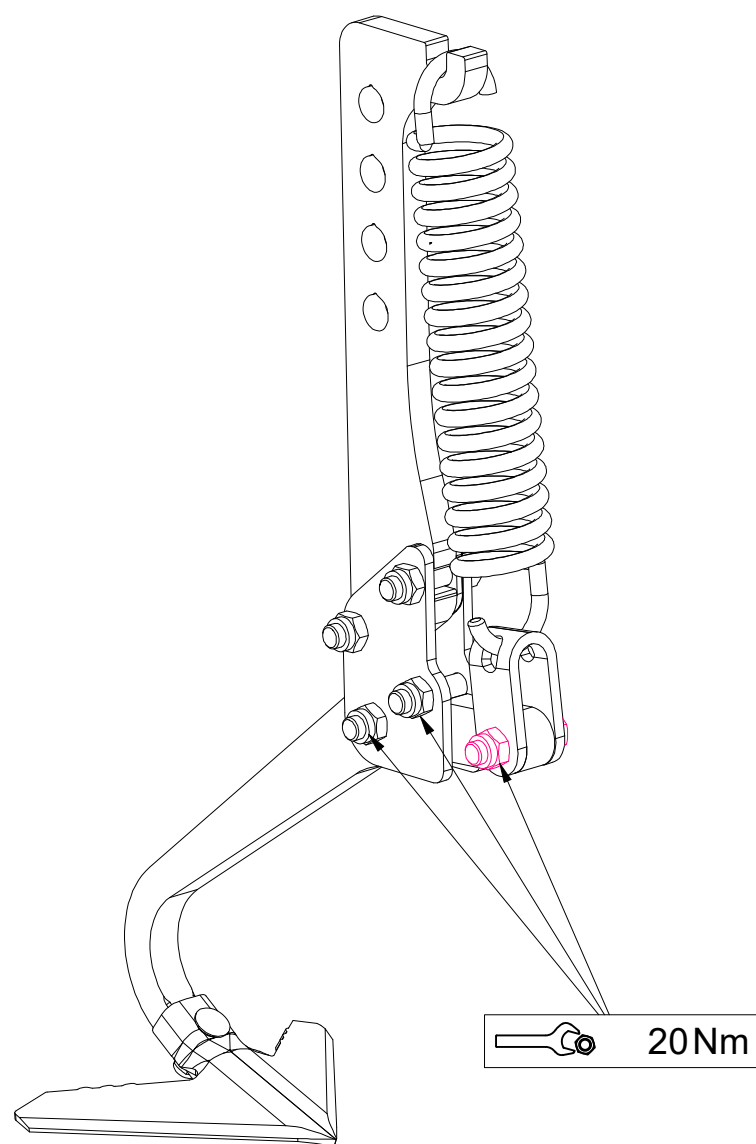

Pos.	Part Number	Pcs.
1	4017307	1
2	4025591	1
3	4005582	2
4	3000236-KOO	1
5	4005445	1
6	m02597	1
7	4005591	1
8	4026202	1
20	m10440	1
22	m06587	5
30	m21001	1
31	m03683	5

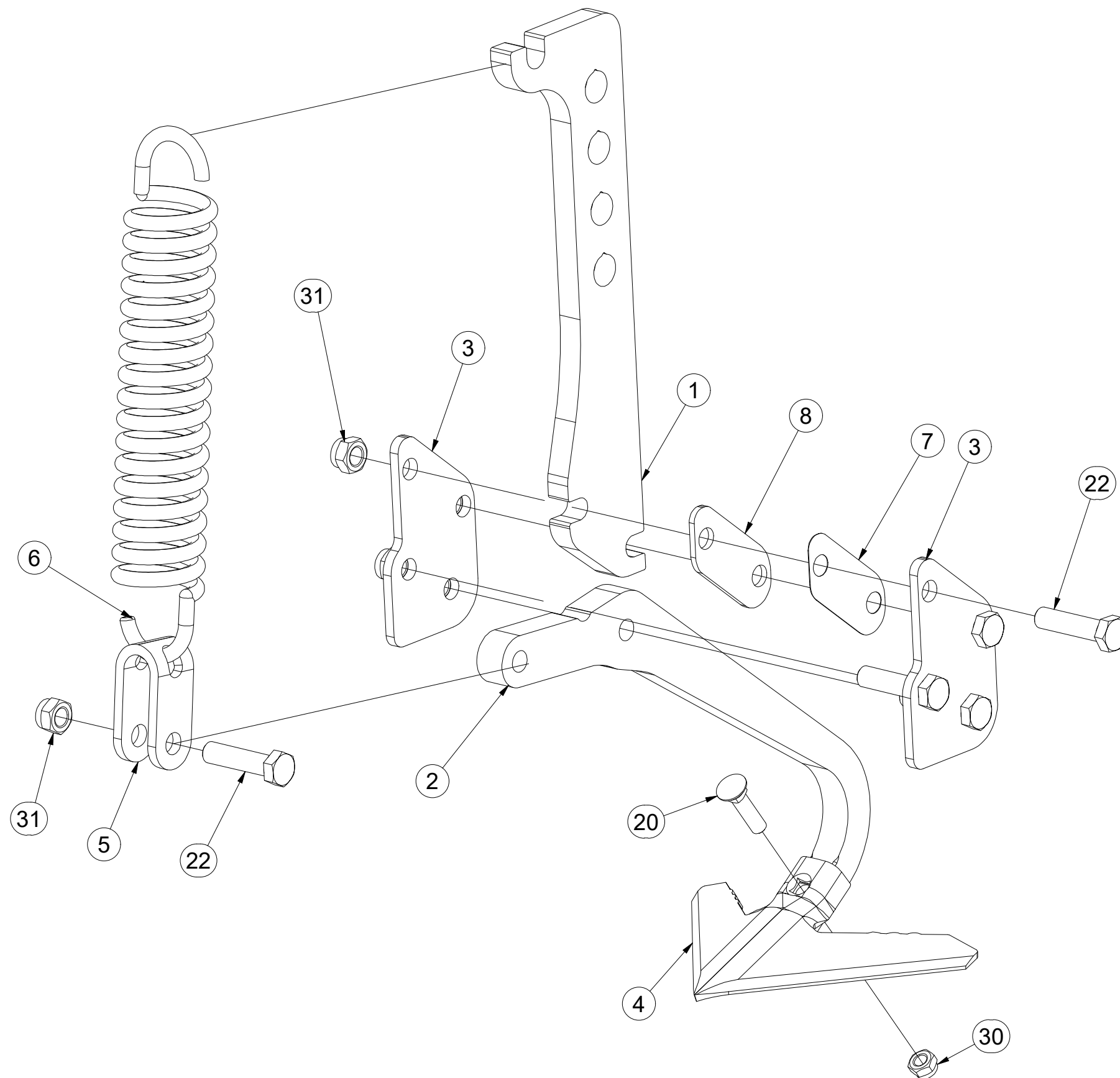

ⒸZ SADA PŘEDNÍCH SMYKŮ

Ⓓ SATZ VORDERE ACKERSCHLEPPEN

Ⓕ KIT DE NIVELEURS AVANT

**VZ00003070**

ⒼB SET OF FRONT LEVELLING BARS

ⒺU КОМПЛЕКТ ПЕРЕДНИХ БОРОН

ⒽL ZESTAW PRZEDNICH WŁÓK

**Farmet**

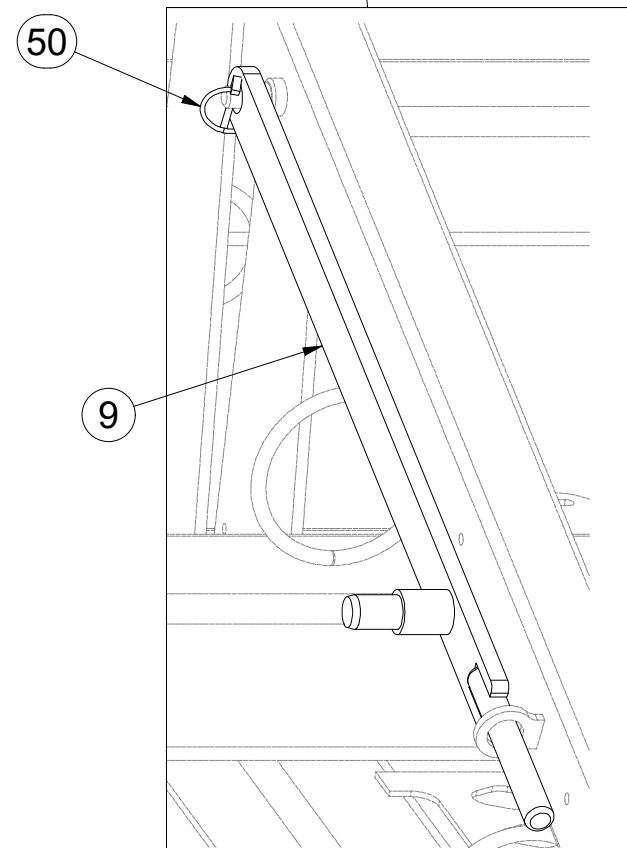
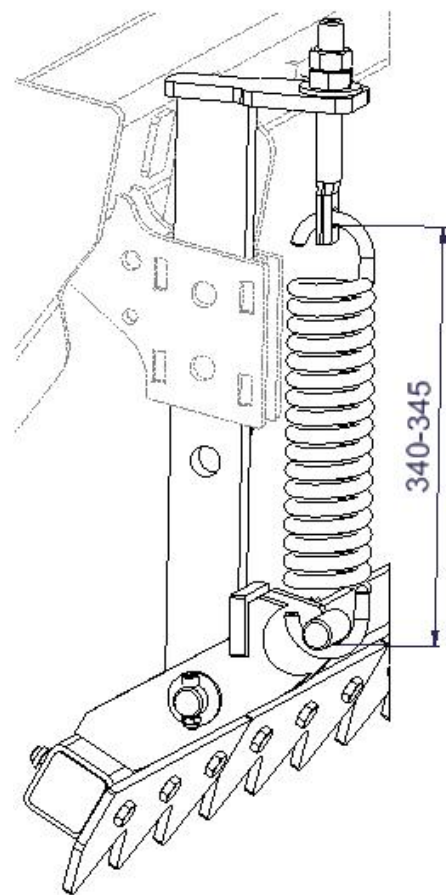
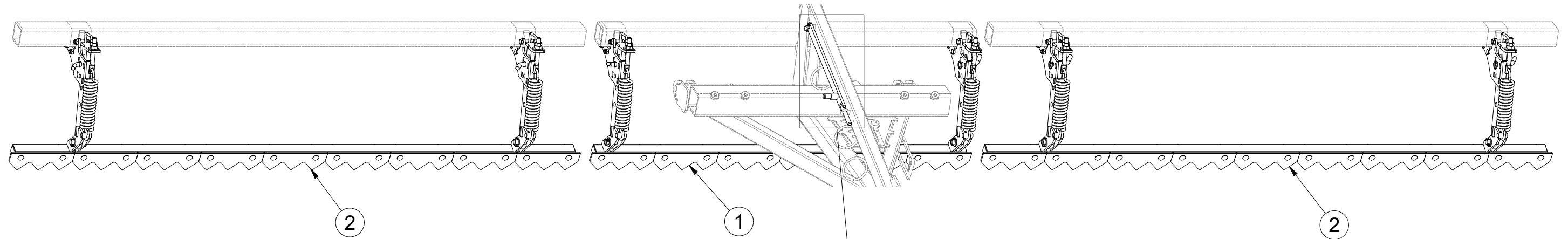

Pos.	Part Number	Pcs.
1	VZ00003364	1
2	VZ00003369	2
9	4006829	1
50	m10454	7

Ⓒ SADA PŘEDNÍCH SMYKŮ

Ⓓ SATZ VORDERE ACKERSCHLEPPEN

Ⓕ KIT DE NIVELEURS AVANT

Ⓖ SET OF FRONT LEVELLING BARS

Ⓡ КОМПЛЕКТ ПЕРЕДНИХ БОРОН

Ⓟ ZESTAW PRZEDNICH WŁÓK



VZ00003070

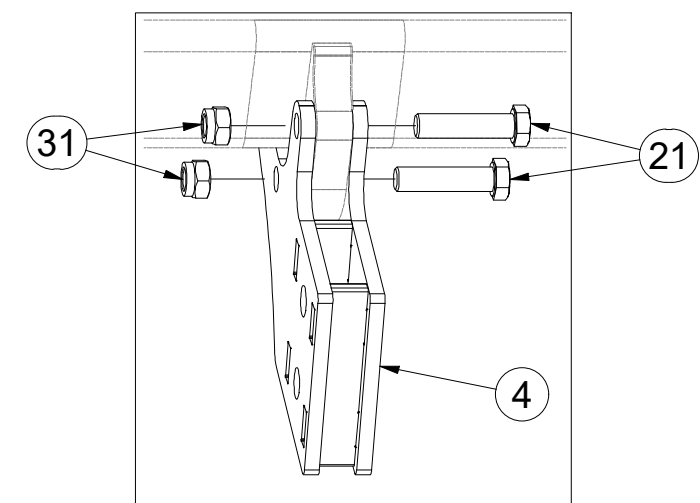
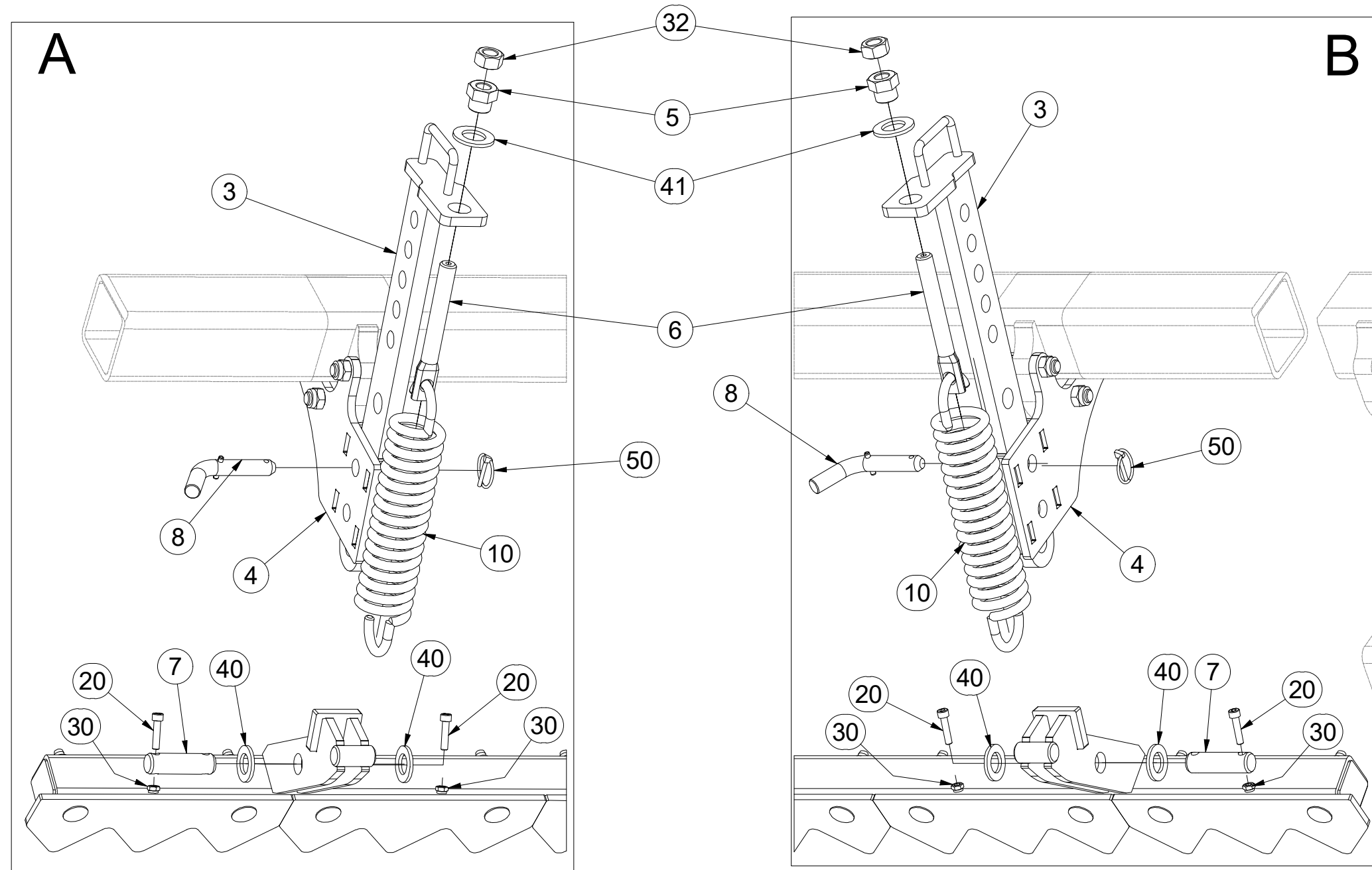
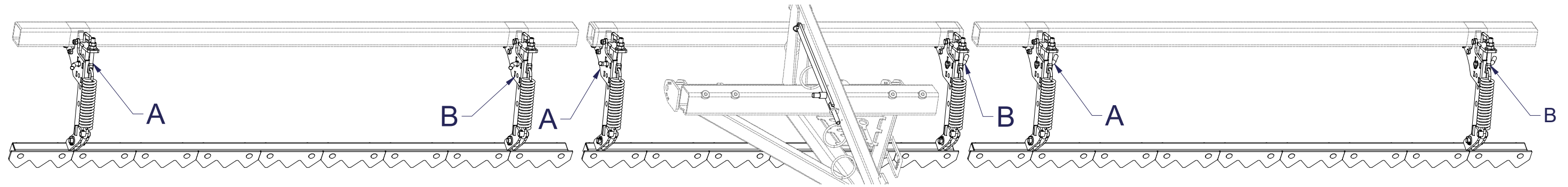

Pos.	Part Number	Pcs.
3	3008686	6
5	4000189	6
6	4003401	6
7	4010390	6
8	4012011	6
4	VZ00003279	6
41	m01225	6
32	m01307	6
10	m02597	6
31	m03683	18
30	m04503	12
21	m06587	18
20	m09464	12
50	m10454	7
40	m14028	12

Ⓒ PŘEDNÍ SMYK

Ⓓ VORDERE ACKERSCHLEIFE

Ⓕ NIVELEUR AVANT

Ⓖ FRONT LEVELLER

Ⓡ ПЕРЕДНЯЯ БОРОНА

Ⓟ PRZEDNIA WŁÓKA

**Farmet**

**VZ00003364**

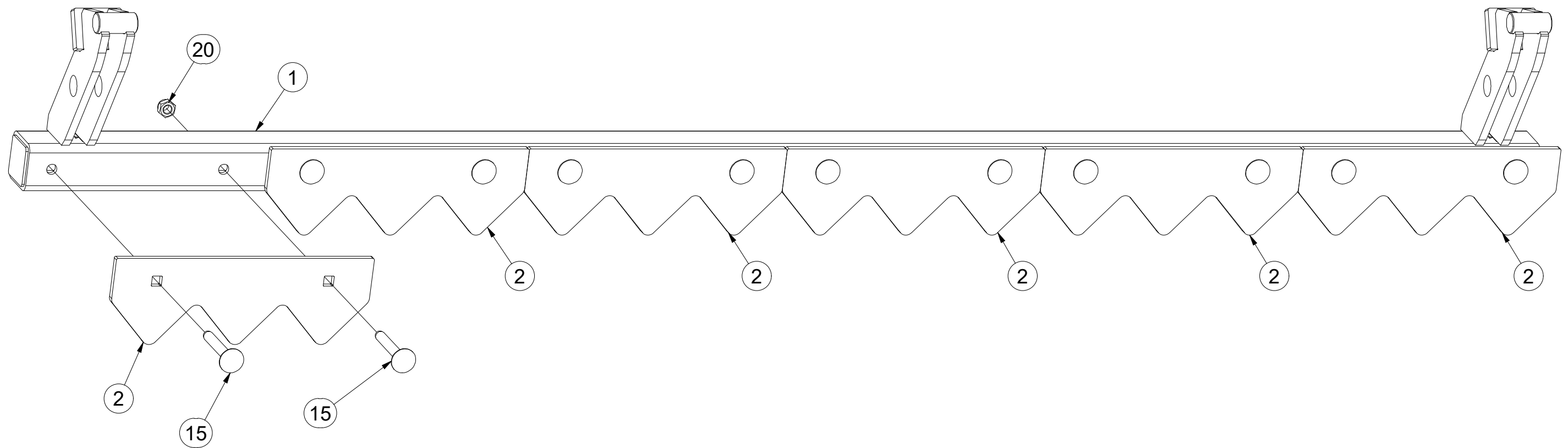
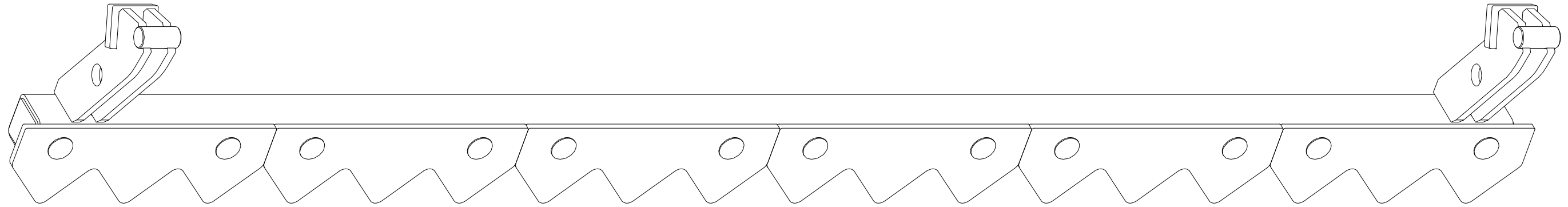

Pos.	Part Number	Pcs.
1	VZ00003365	1
2	VZ00003366	6
15	m08339	12
20	m04301	12

Ⓒ PŘEDNÍ SMYK

Ⓓ VORDERE ACKERSCHLEIFE

Ⓕ NIVELEUR AVANT

Ⓖ FRONT LEVELLER

Ⓡ ПЕРЕДНЯЯ БОРОНА

Ⓟ PRZEDNIA WŁÓKA

**Farmet**

**VZ00003369**

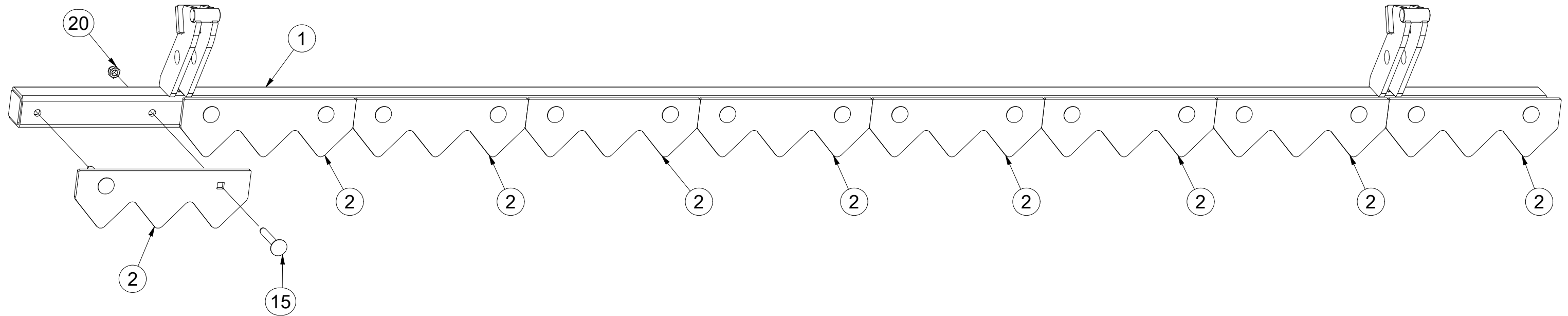
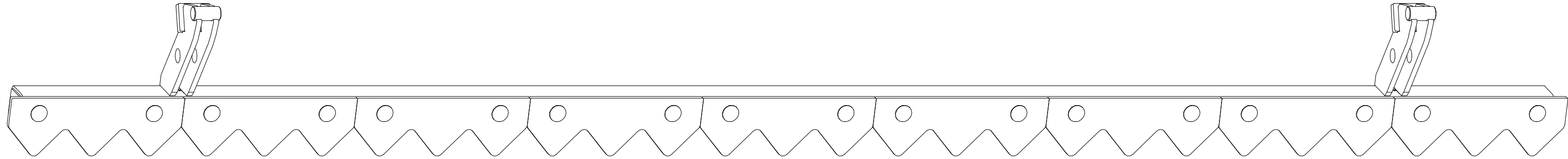

Pos.	Part Number	Pcs.
1	VZ00003370	1
2	VZ00003366	9
15	m08339	18
20	m04301	18

ⒸZ SADA PŘEDNÍCH VÁLCŮ

Ⓓ SATZ VORDERE WALZEN

Ⓕ KIT DE ROULEAUX AVANT

**VZ00040128**

ⒼB SET OF FRONT ROLLERS

ⒺU КОМПЛЕКТ ПЕРЕДНИХ КАТКОВ

ⒼL ZESTAW PRZEDNICH WAŁÓW

**Farmet**

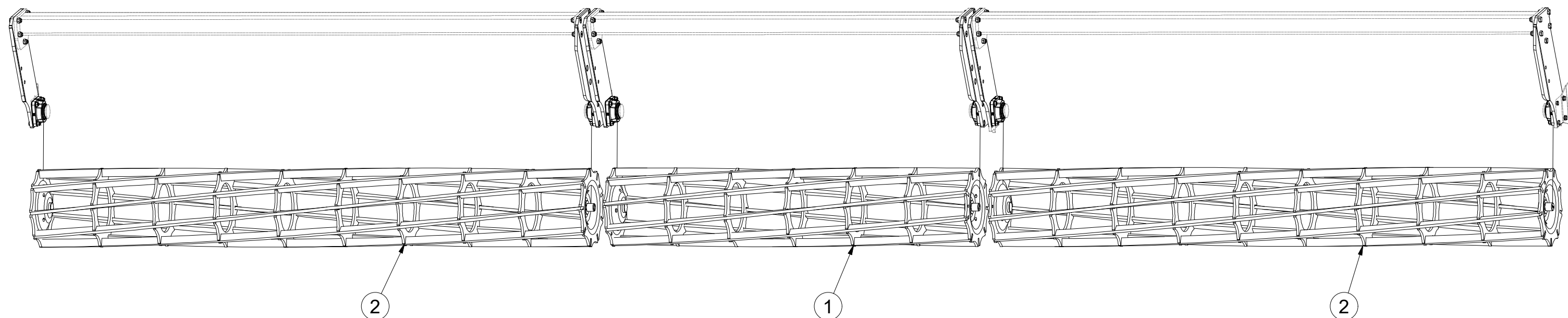

Pos.	Part Number	Pcs.
1	VZ00037622	1
2	VZ00039726	2

ⒸZ SADA PŘEDNÍCH VÁLCŮ

Ⓓ SATZ VORDERE WALZEN

Ⓕ KIT DE ROULEAUX AVANT

ⒼB SET OF FRONT ROLLERS

ⒺR КОМПЛЕКТ ПЕРЕДНИХ КАТКОВ

ⒺP ZESTAW PRZEDNICH WAŁÓW



**VZ00040128**

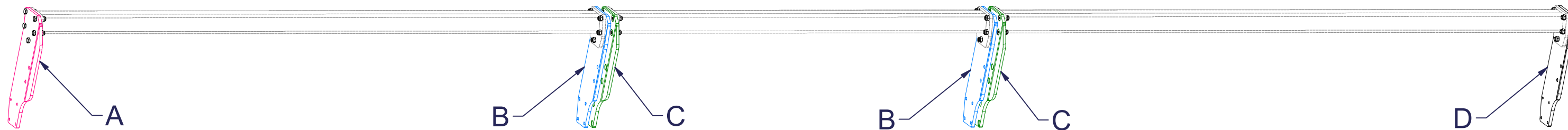

Pos.	Part Number	Pcs.
3	VZ00008662	2
4	VZ00008663	2
5	VZ00008664	1
6	VZ00008665	1
15	m14672	20
16	m10849	10
20	m20385	30

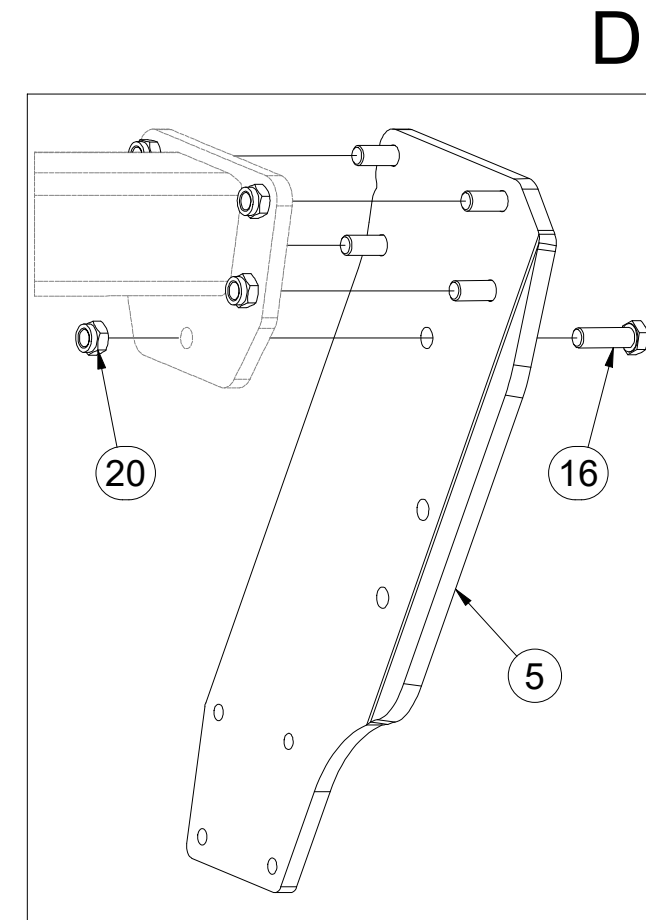
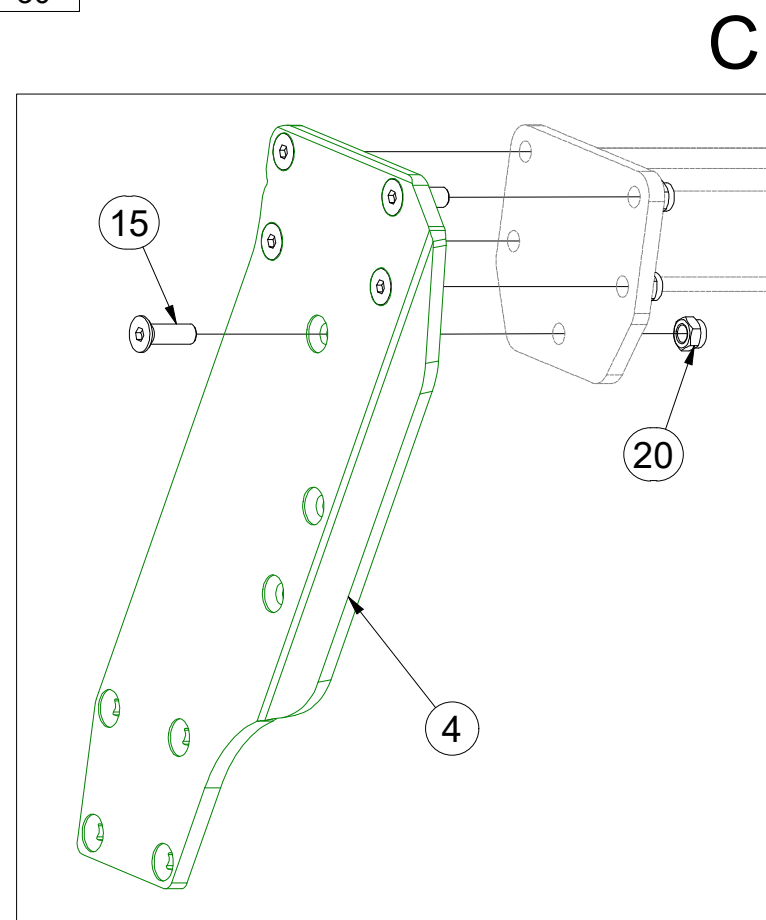
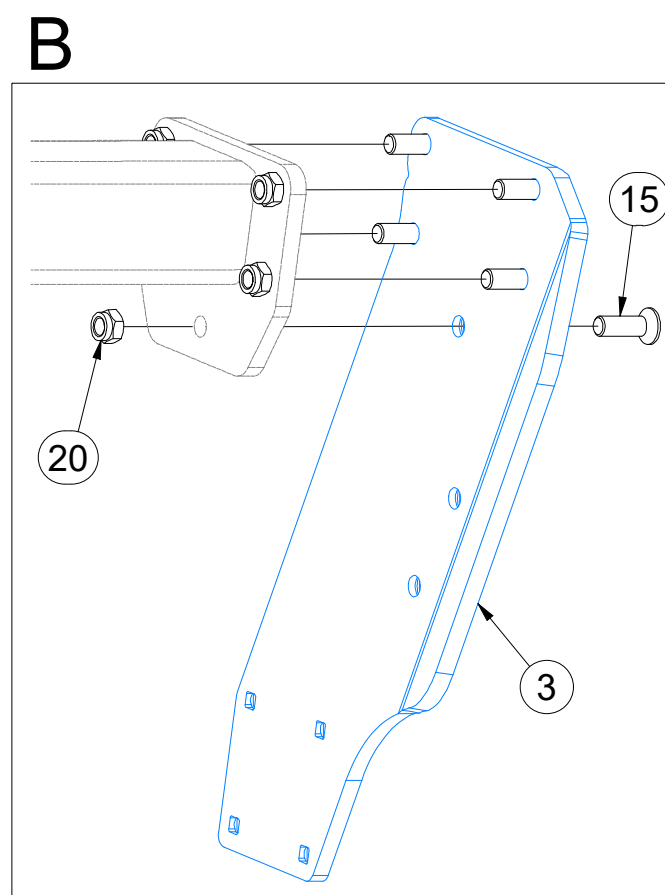
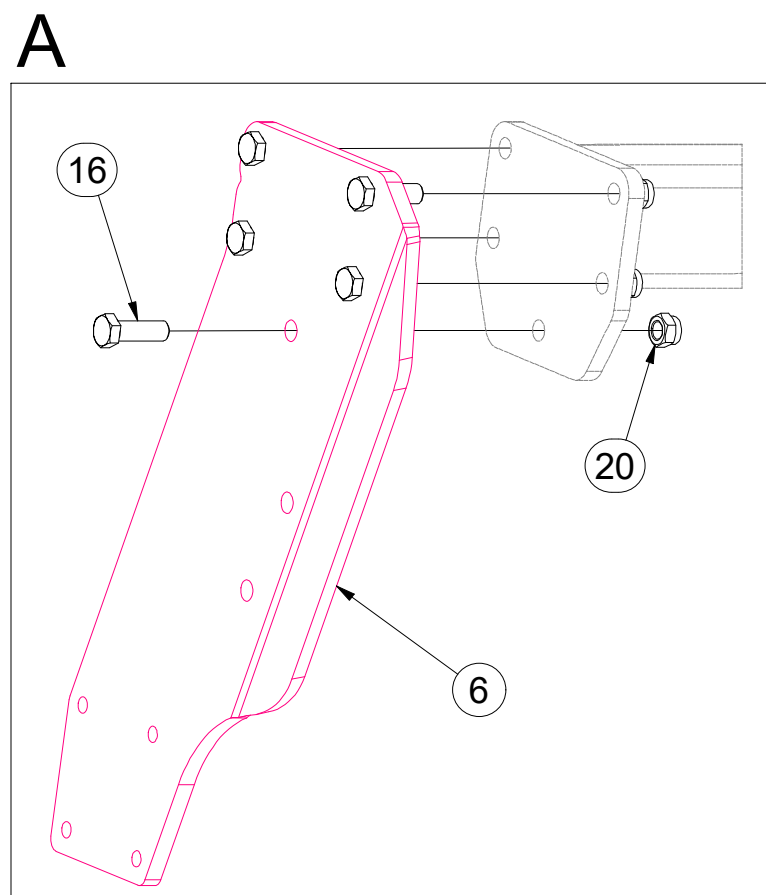

Ⓒ SADA PŘEDNÍCH VÁLCŮ

Ⓓ SATZ VORDERE WALZEN

Ⓕ KIT DE ROULEAUX AVANT

Ⓖ SET OF FRONT ROLLERS

Ⓡ КОМПЛЕКТ ПЕРЕДНИХ КАТКОВ

Ⓟ ZESTAW PRZEDNICH WAŁÓW

**Farmet**

**VZ00040128**



Pos.	Part Number	Pcs.
10	VZ00038060	4
11	VZ00040131	2

A

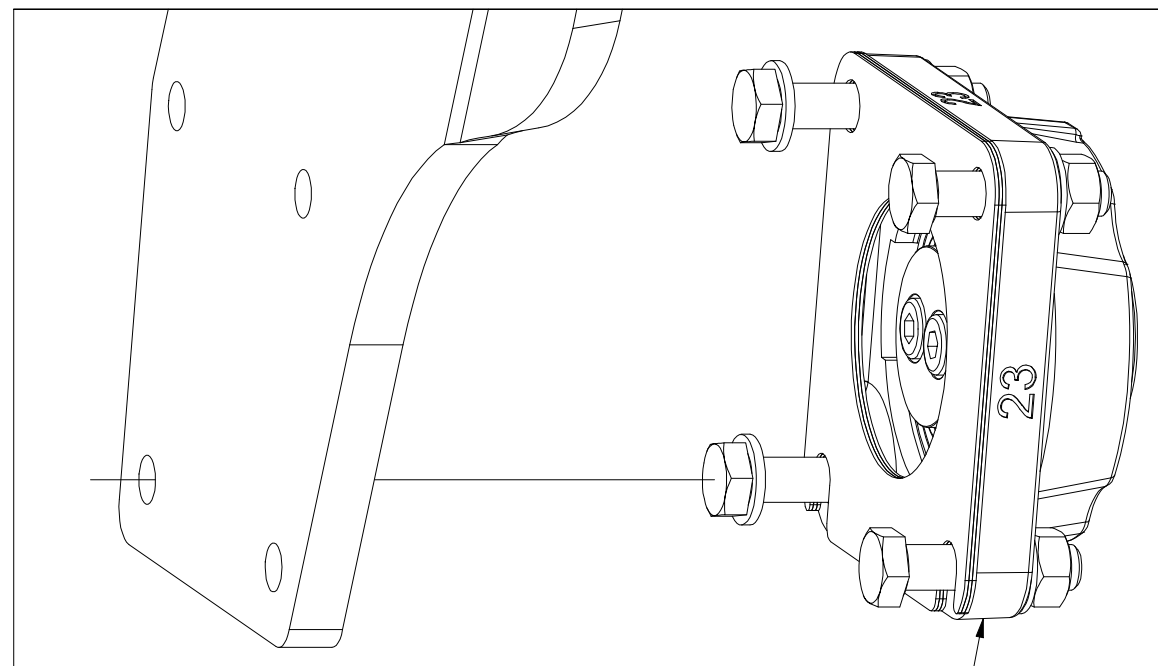

11

B

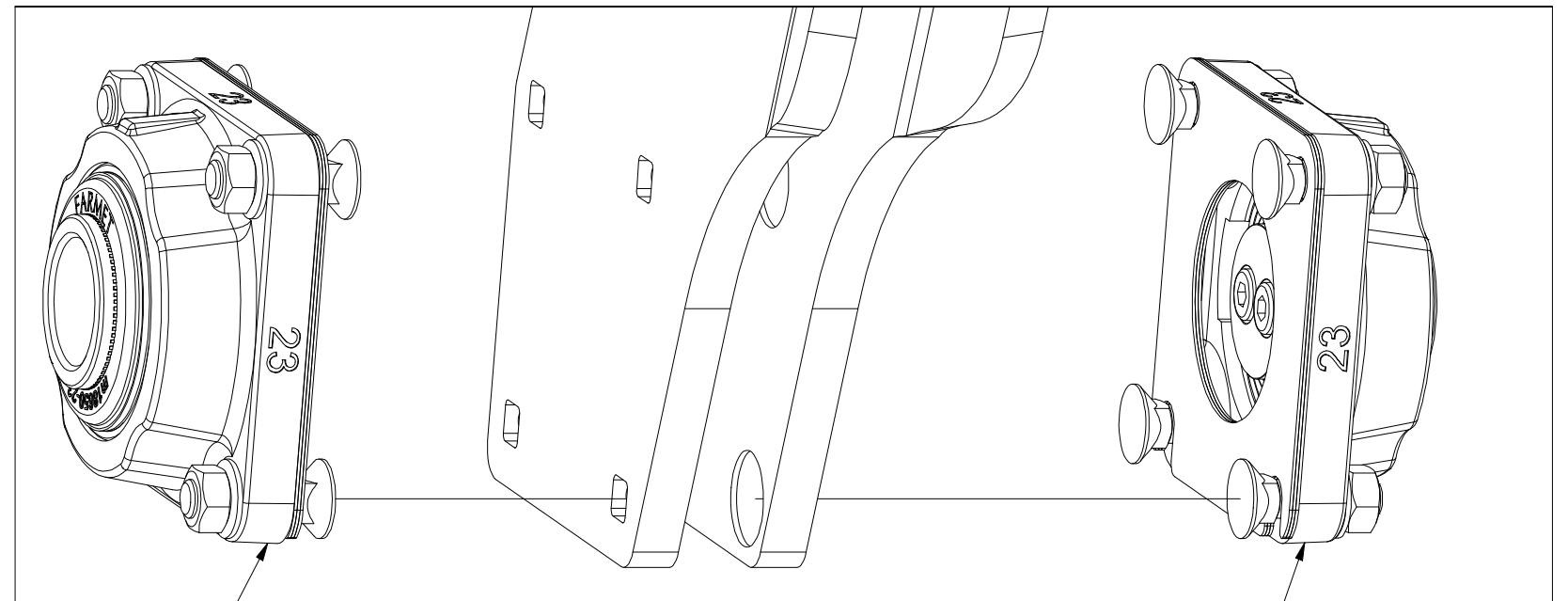

10

10



CZ SADA LOŽISEK  
 D SATZ LAGER  
 F KIT DE ROULEMENTS

GB SET OF BEARINGS  
 RU КОМПЛЕКТ ПОДШИПНИКОВ  
 PL ZESTAW ŁOŻYSK



**VZ00038060**

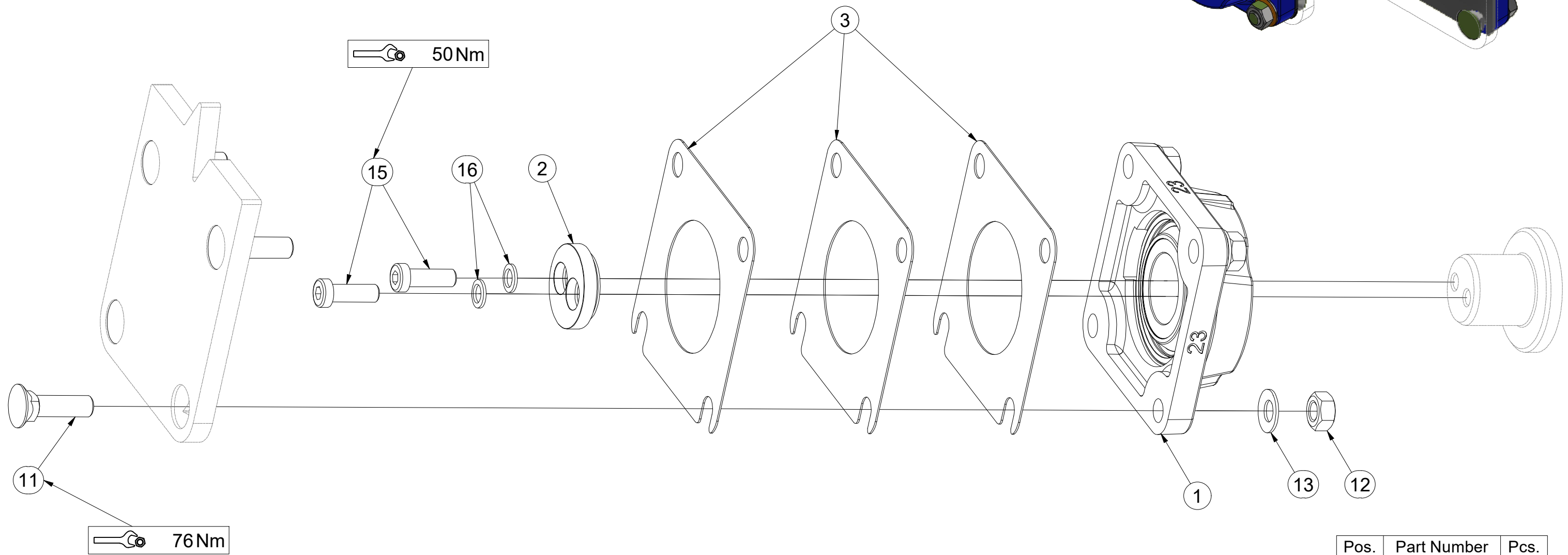
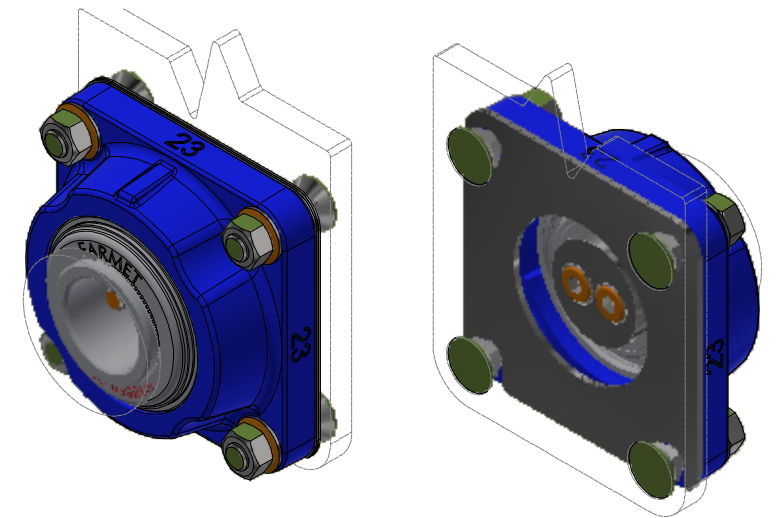

Pos.	Part Number	Pcs.
1	m18650-23	1
2	VZ00038211	1
3	4016809	3
11	m03519	4
12	m01305	4
13	m17545	4
15	m24320	2
16	m24356	2

CZ SADA LOŽISEK  
 D SATZ LAGER  
 F KIT DE ROULEMENTS

GB SET OF BEARINGS  
 RU КОМПЛЕКТ ПОДШИПНИКОВ  
 PL ZESTAW ŁOŻYSK



**VZ00040131**

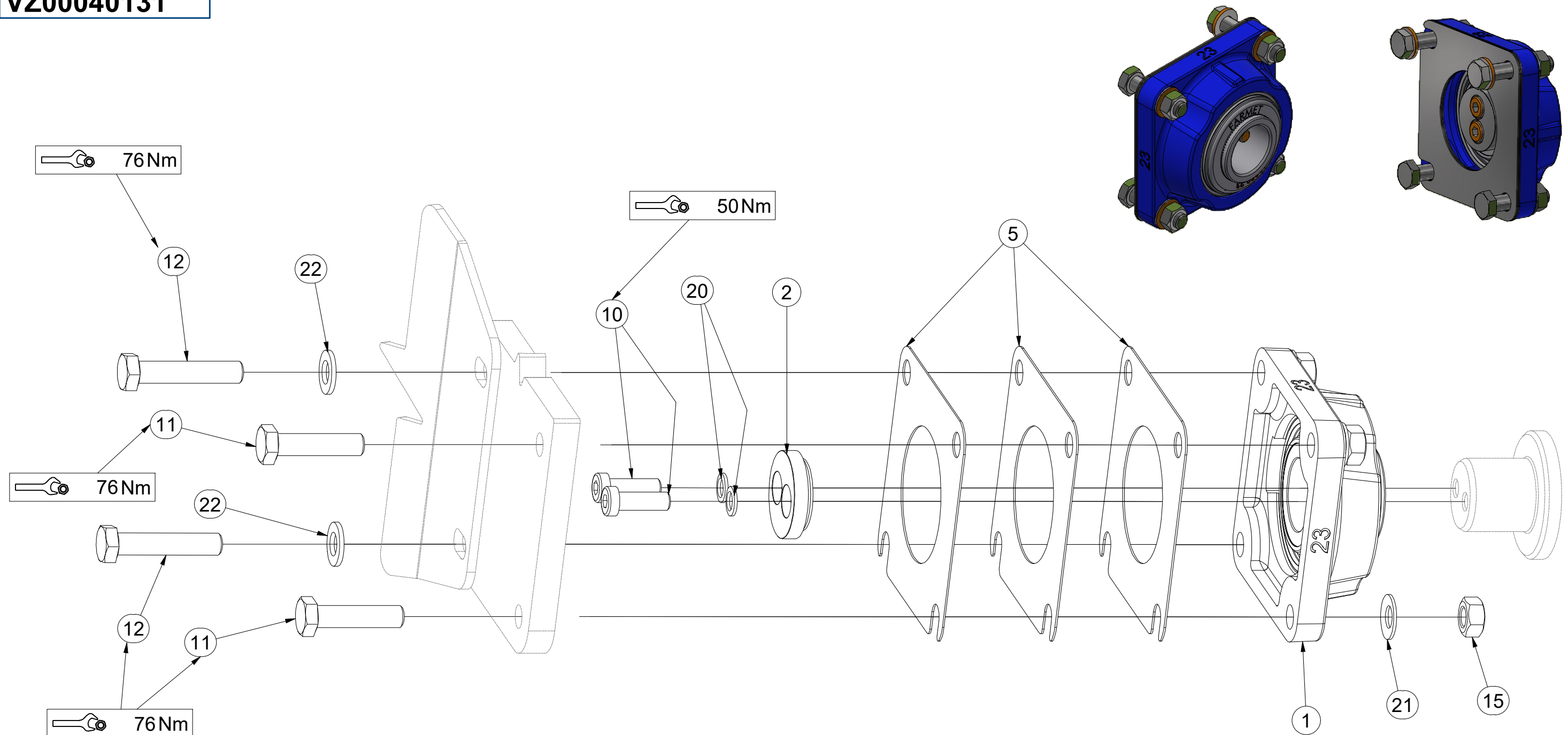

Pos.	Part Number	Pcs.
1	m18650-23	1
2	VZ00038211	1
5	4016809	3
10	m24320	2
11	m03339	2
12	m01131	2
15	m01305	4
20	m24356	2
21	m17545	4
22	m17741	2

**VZ00038564**

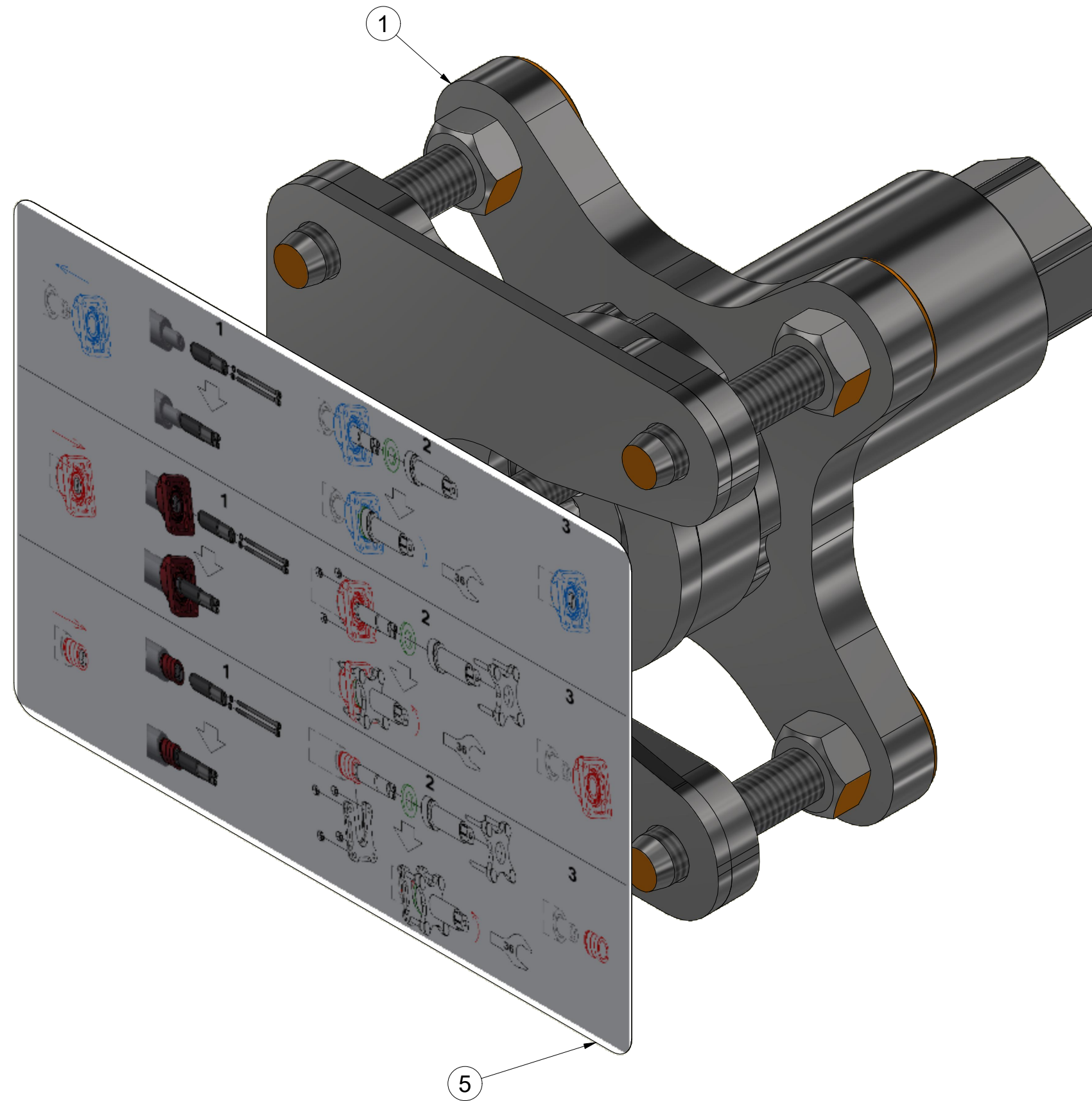

Pos.	Part Number	Pcs.
1	VZ00040530	1
5	m24596	1

VZ00040530

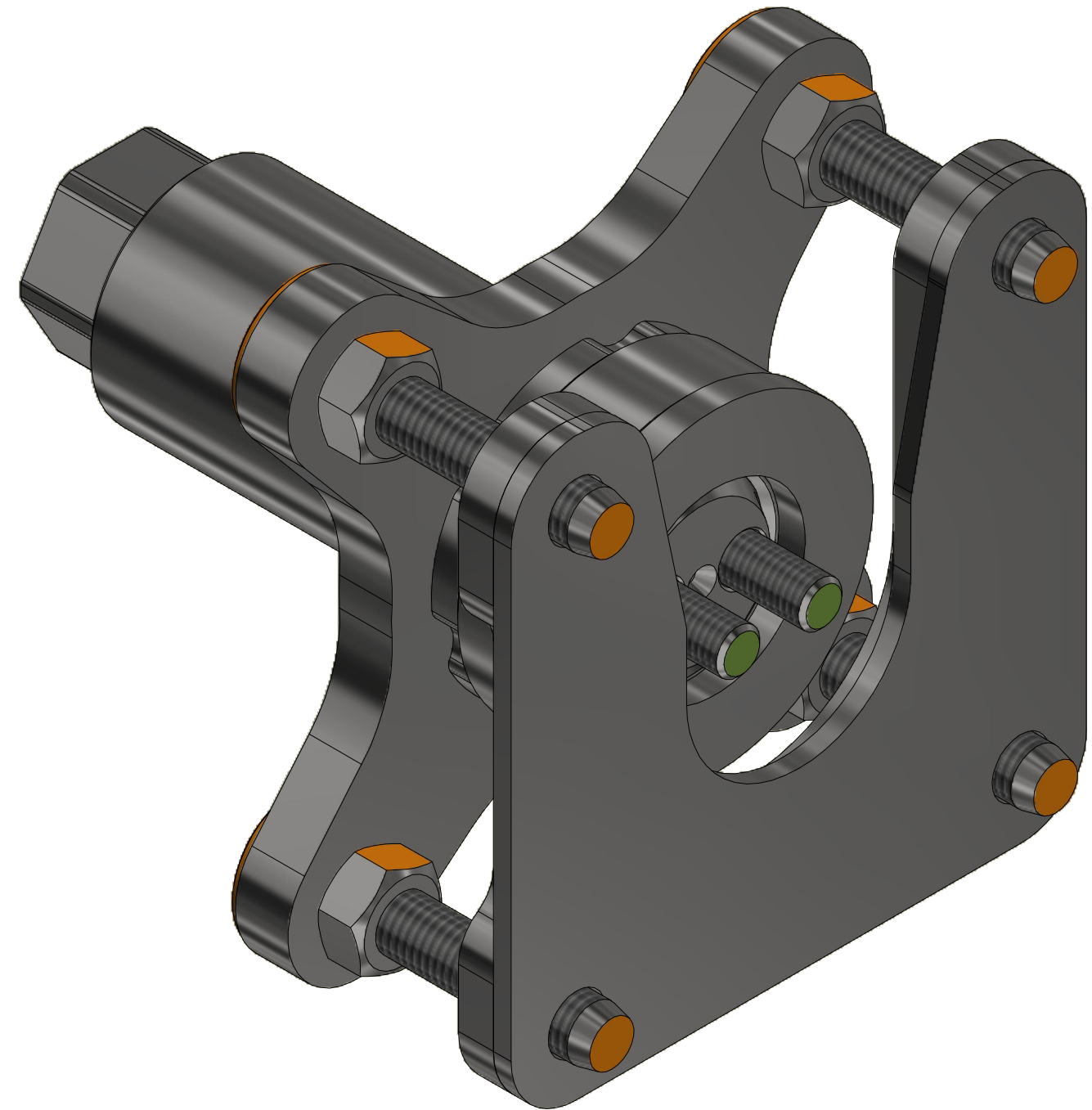
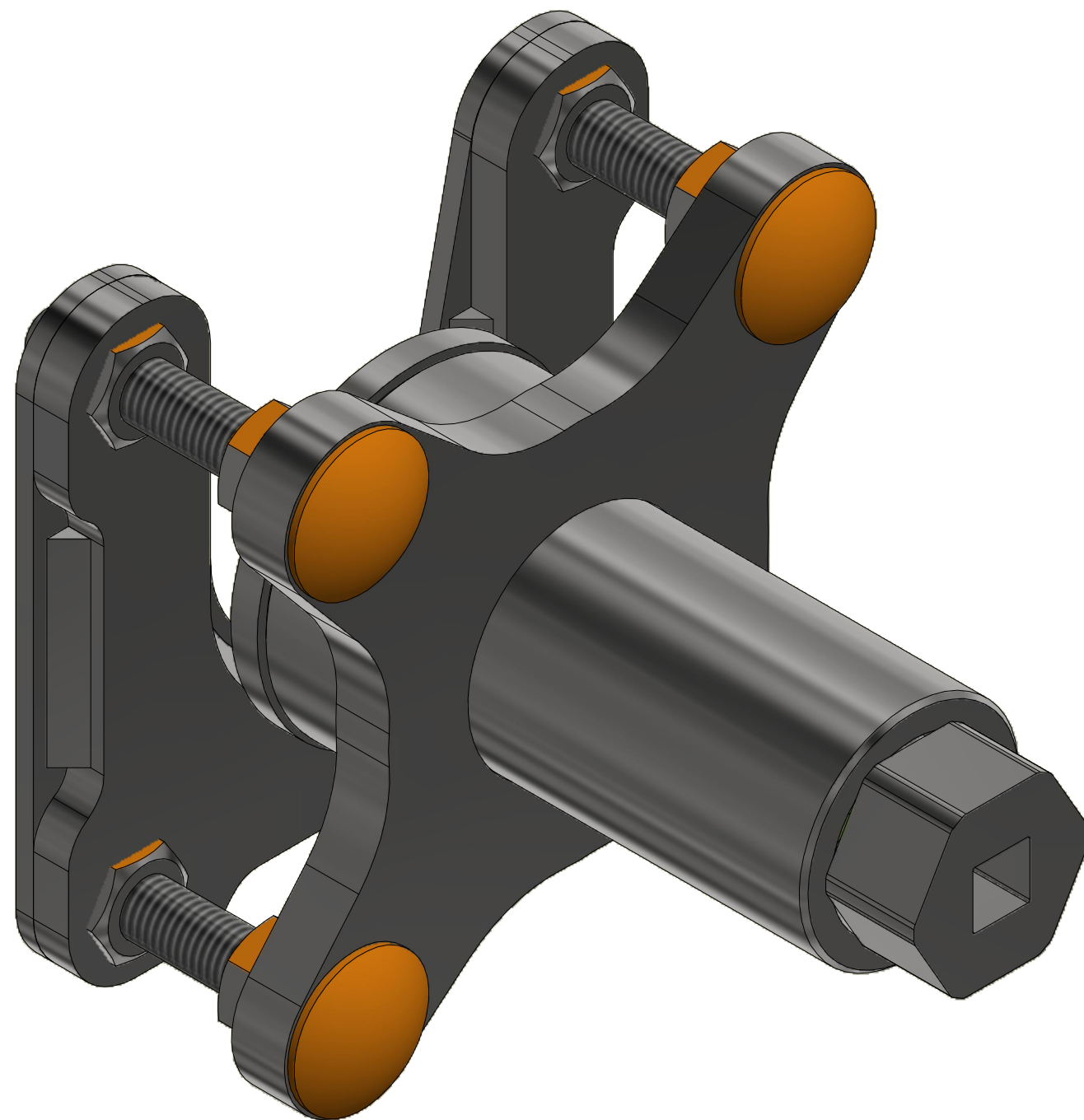

**VZ00040530**

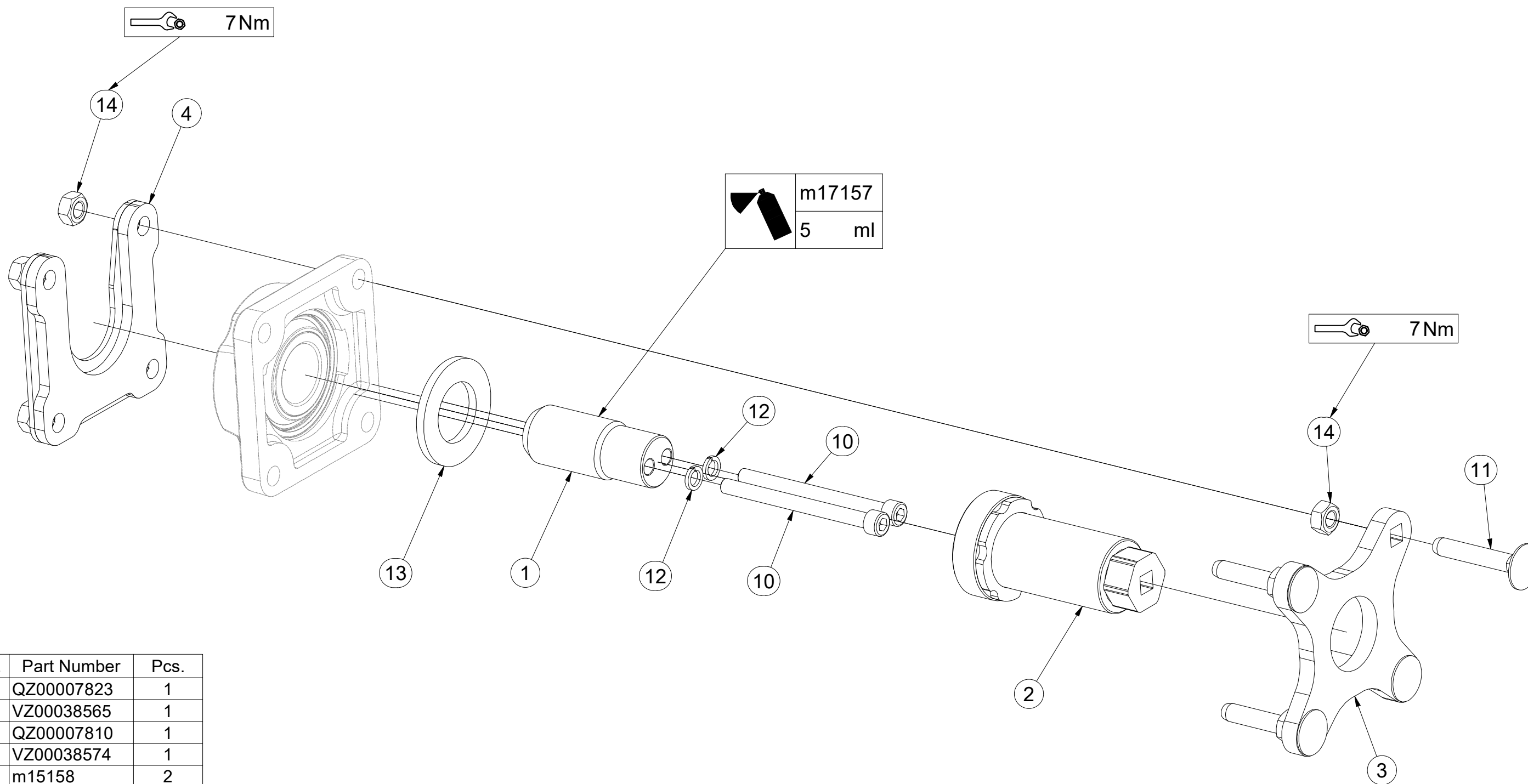

Pos.	Part Number	Pcs.
1	QZ00007823	1
2	VZ00038565	1
3	QZ00007810	1
4	VZ00038574	1
10	m15158	2
11	m17684	4
12	m01208	2
13	m03636	1
14	m10439	8
20	m17157	5,00 ml

Ⓒ SADA OVLÁDÁNÍ RADLICE

Ⓓ STEUERSATZ PFLUGSCHAR/PFLUGSCHAREN

Ⓕ KIT DE COMMANDE DU SOC/DES SOCS

Ⓖ SET OF PLOUGHSHARE CONTROL

Ⓡ КОМПЛЕКТ УПРАВЛЕНИЯ ЛАПЫ/ЛАП

Ⓢ ZESTAW STEROWANIA REDLIÇA/RADLICAMI



**VZ00038374**

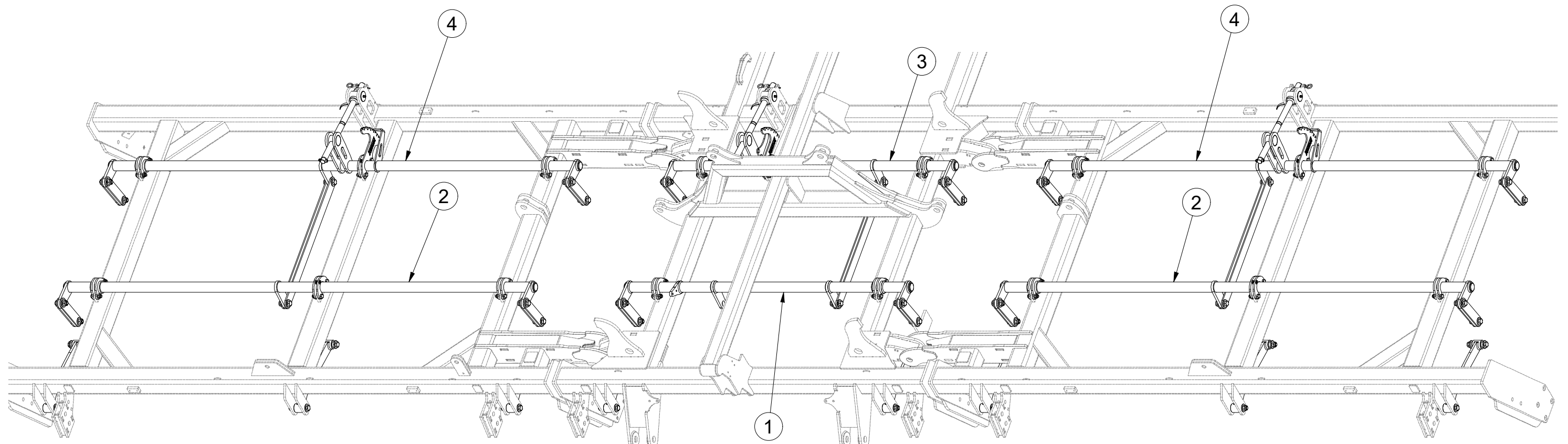

Pos.	Part Number	Pcs.
1	VZ00007199	1
2	3002863	2
3	VZ00039394	1
4	3002864	2

Ⓒ SADA OVLÁDÁNÍ RADLICE

Ⓓ STEUERSATZ PFLUGSCHAR/PFLUGSCHAREN

Ⓕ KIT DE COMMANDE DU SOC/DES SOCS

**VZ00038374**

Pos.	Part Number	Pcs.
1	VZ00007199	1
3	VZ00039394	1
10	4005332	24
26	m10130	12
32	m06077	34
42	m04301	34

Ⓖ SET OF PLOUGHSHARE CONTROL

Ⓔ КОМПЛЕКТ УПРАВЛЕНИЯ ЛАПЫ/ЛАП

Ⓗ ZESTAW STEROWANIA REDLICA/RADLICAMI

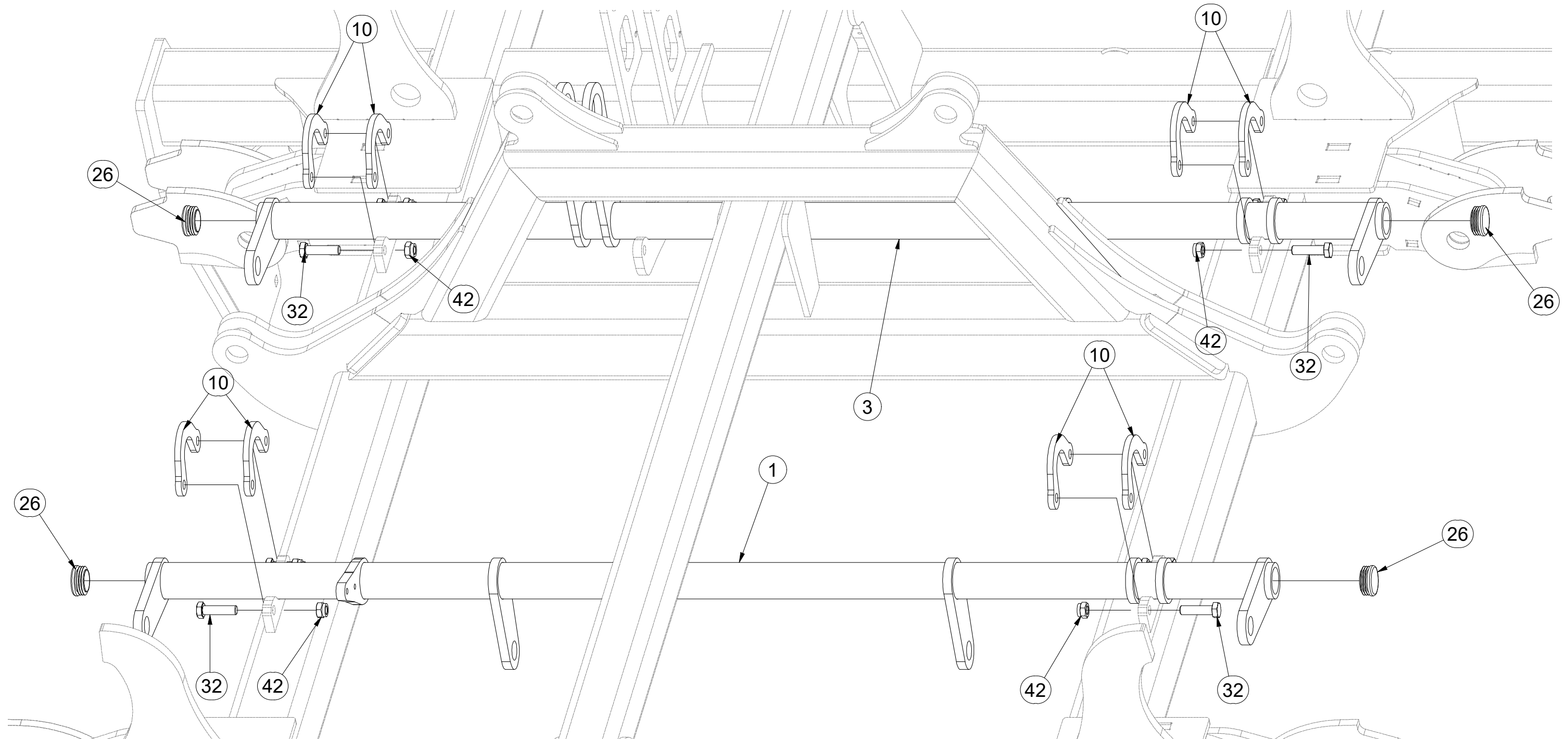
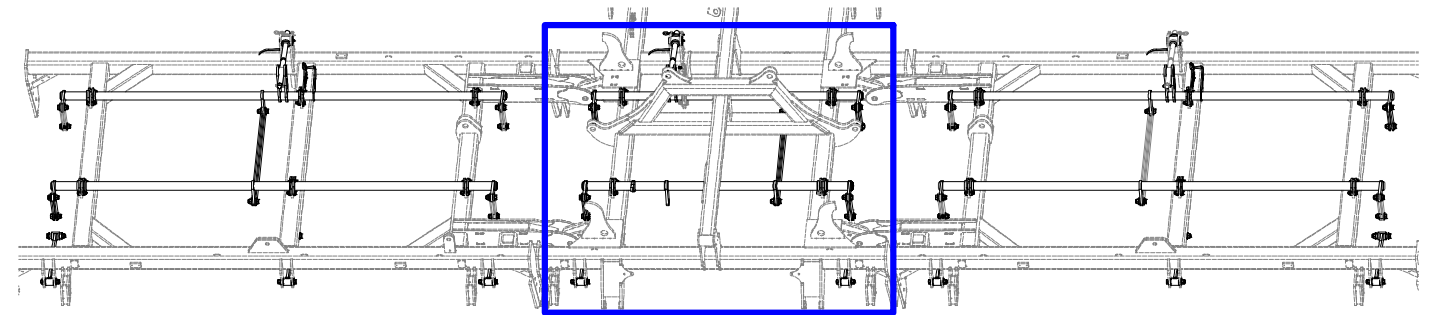

Ⓒ SADA OVLÁDÁNÍ RADLICE

Ⓓ STEUERSATZ PFLUGSCHAR/PFLUGSCHAREN

Ⓕ KIT DE COMMANDE DU SOC/DES SOCS

Ⓖ SET OF PLOUGHSHARE CONTROL

Ⓡ КОМПЛЕКТ УПРАВЛЕНИЯ ЛАПЫ/ЛАП

Ⓟ ZESTAW STEROWANIA REDLIĆ/RADLICAMI



**VZ00038374**

Pos.	Part Number	Pcs.
2	3002863	2
4	3002864	2
9	4022084	7
10	4005332	24
26	m10130	12
32	m06077	34
42	m04301	34

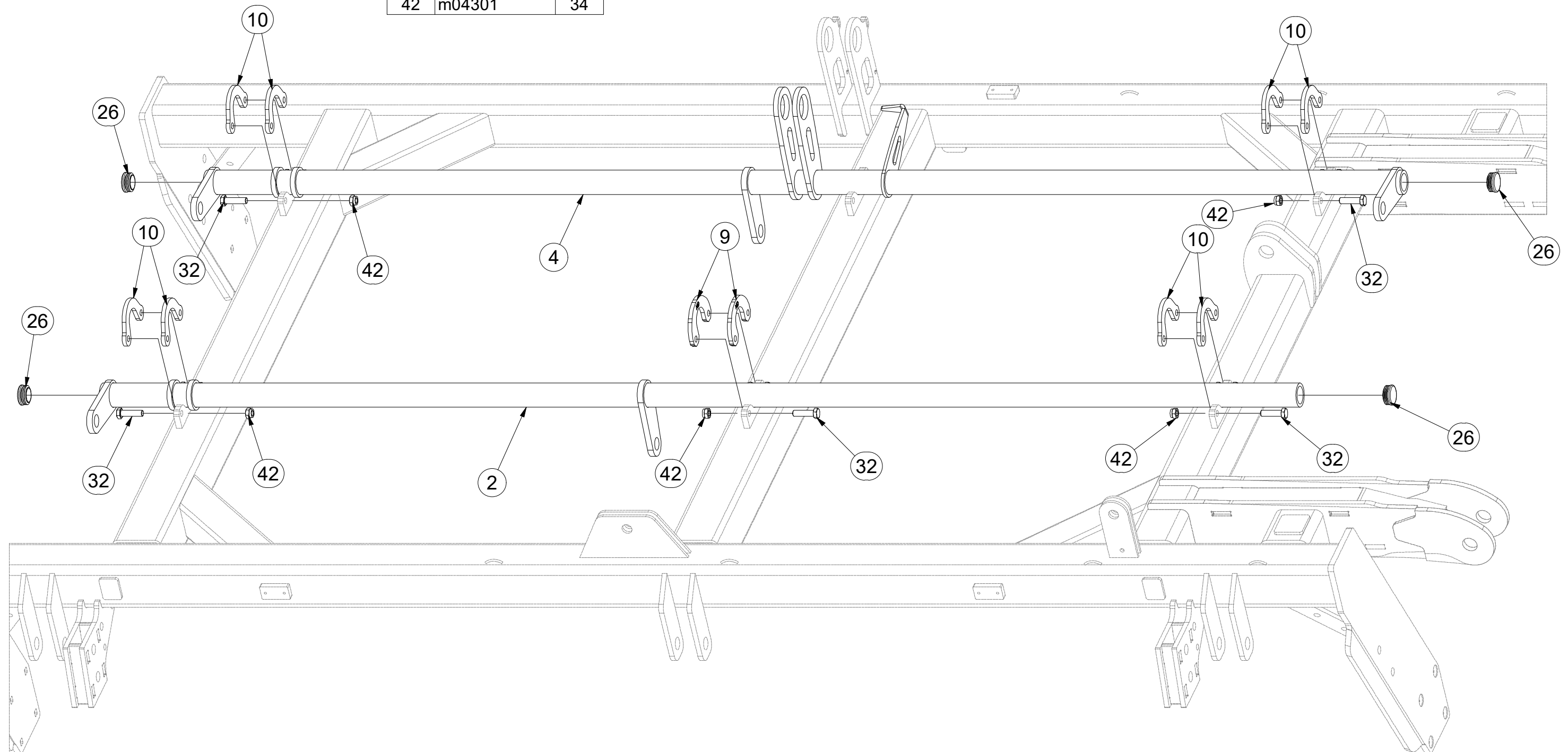
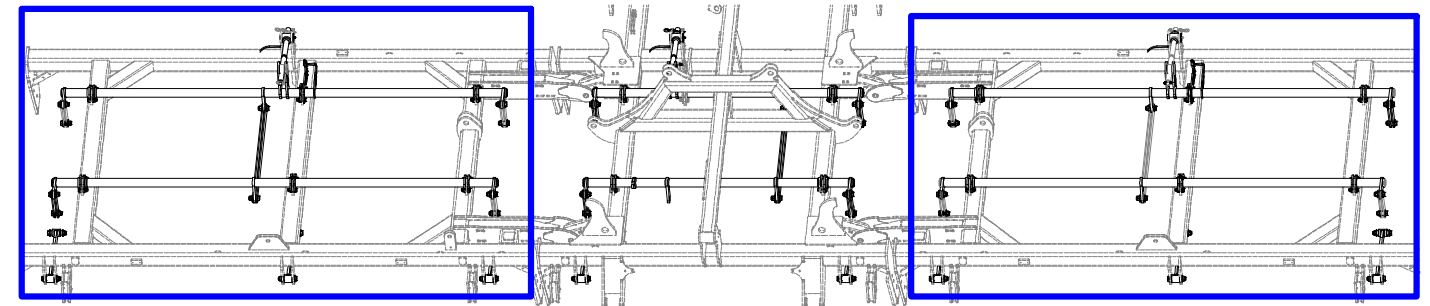



Ⓒ SADA OVLÁDÁNÍ RADLICE

Ⓓ STEUERSATZ PFLUGSCHAR/PFLUGSCHAREN

Ⓕ KIT DE COMMANDE DU SOC/DES SOCS

Ⓖ SET OF PLOUGHSHARE CONTROL

Ⓔ КОМПЛЕКТ УПРАВЛЕНИЯ ЛАПЫ/ЛАП

Ⓗ ZESTAW STEROWANIA REDLIĆA/RADLICAMI



**VZ00038374**

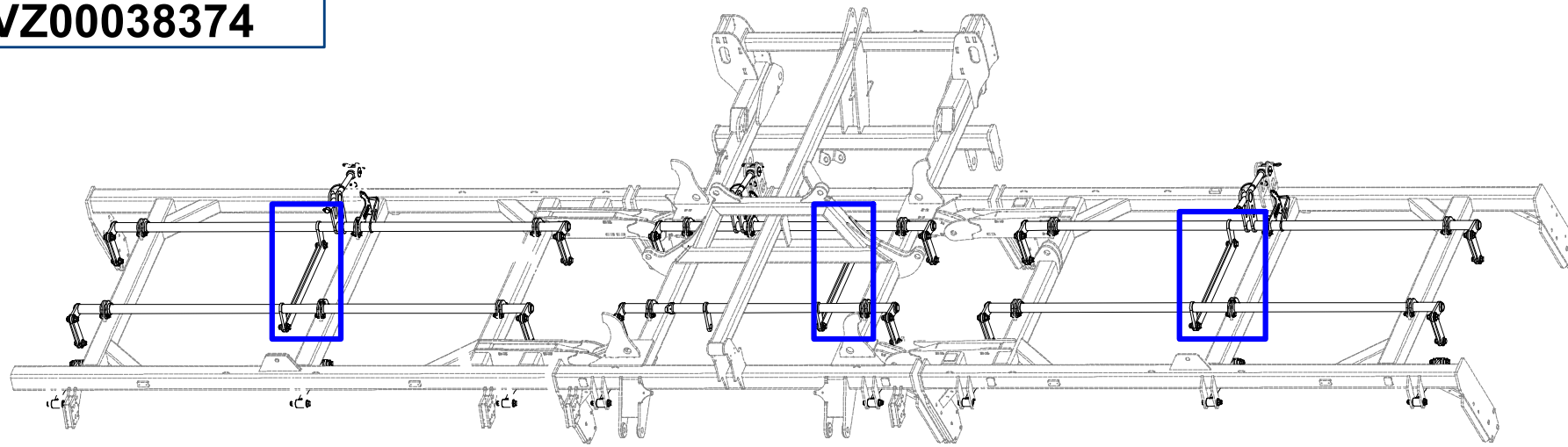

Pos.	Part Number	Pcs.
6	4005334	6
14	4002265	30
33	m04355	30
43	m03683	46
50	m05651	92

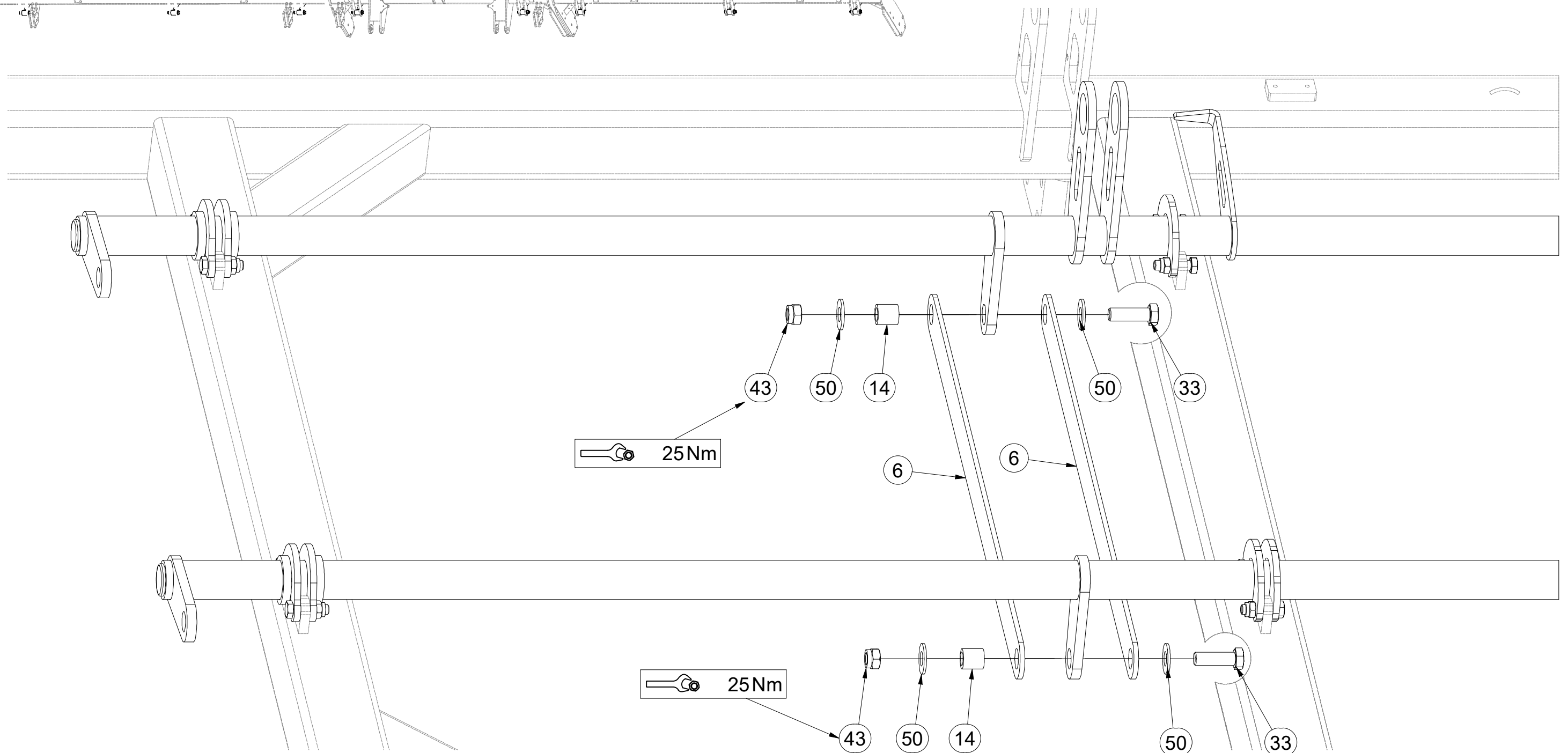

ⒸZ SADA OVLÁDÁNÍ RADLICE

Ⓓ STEUERSATZ PFLUGSCHAR/PFLUGSCHAREN

Ⓕ KIT DE COMMANDE DU SOC/DES SOCS

ⒸB SET OF PLOUGHSHARE CONTROL

ⒸU КОМПЛЕКТ УПРАВЛЕНИЯ ЛАПЫ/ЛАП

ⒸL ZESTAW STEROWANIA REDLICA/RADLICAMI



**VZ00038374**

Pos.	Part Number	Pcs.
18	VZ00039935	1
30	m12431	3
40	m05560	3

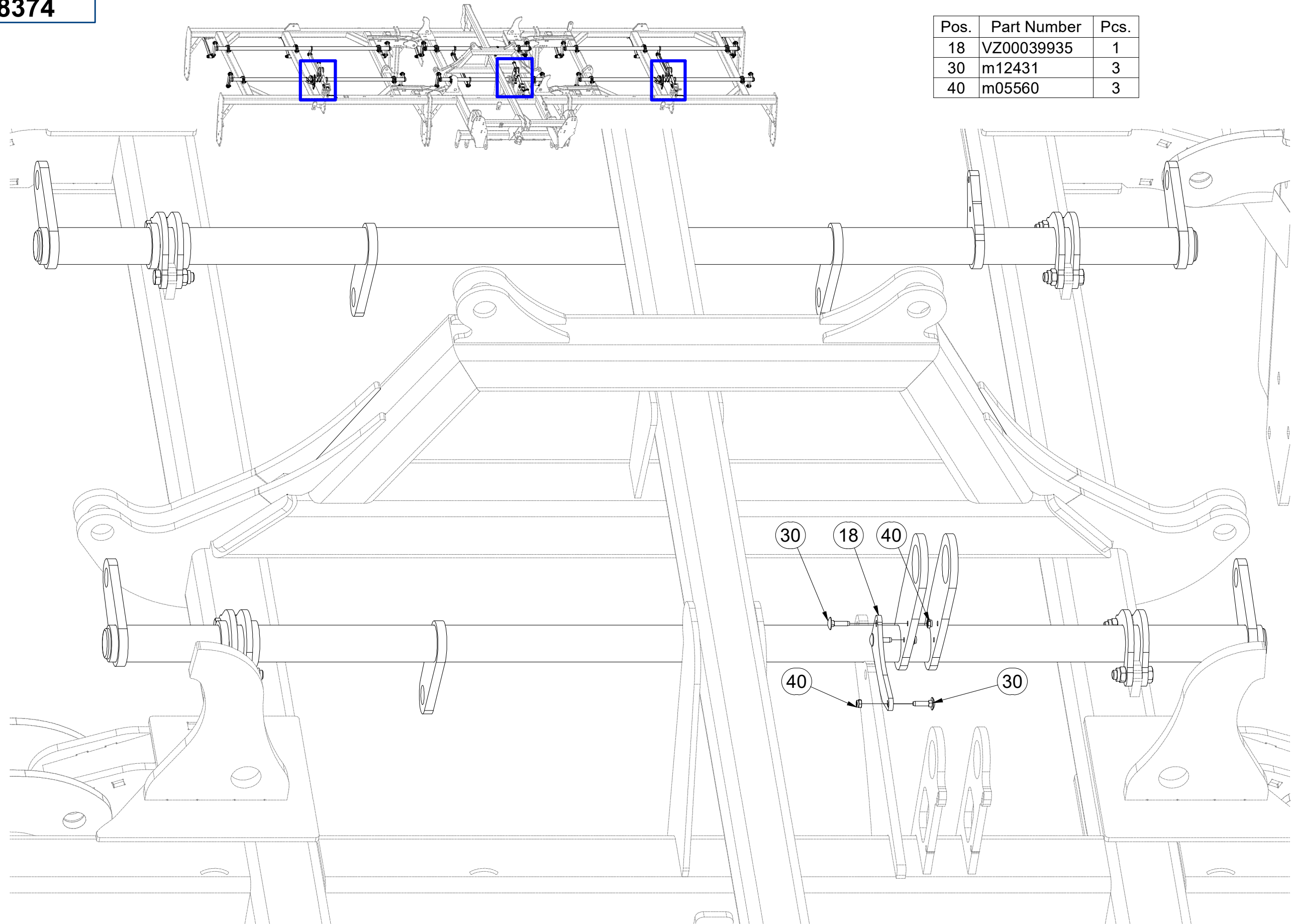

Ⓒ SADA OVLÁDÁNÍ RADLICE

Ⓓ STEUERSATZ PFLUGSCHAR/PFLUGSCHAREN

Ⓕ KIT DE COMMANDE DU SOC/DES SOCS

Ⓖ SET OF PLOUGHSHARE CONTROL

Ⓡ КОМПЛЕКТ УПРАВЛЕНИЯ ЛАПЫ/ЛАП

Ⓢ ZESTAW STEROWANIA REDLIĆ/RADLICAMI



**VZ00038374**

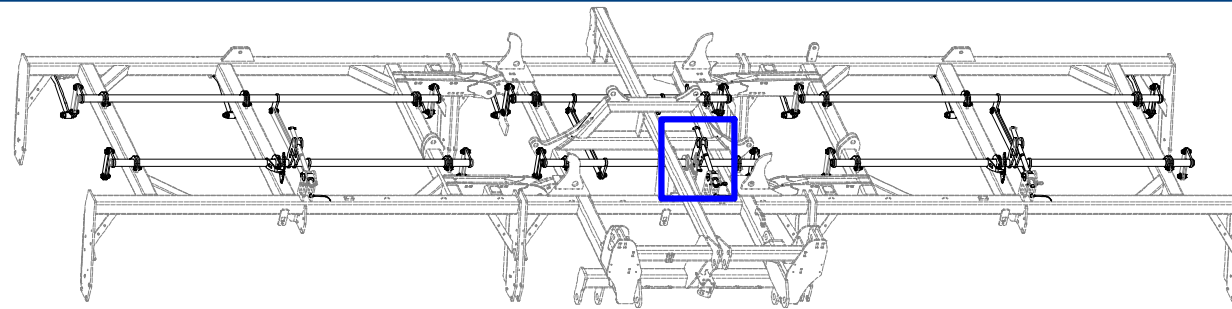

Pos.	Part Number	Pcs.
9	4022084	7
17	VZ00037139	3
32	m06077	34
42	m04301	34

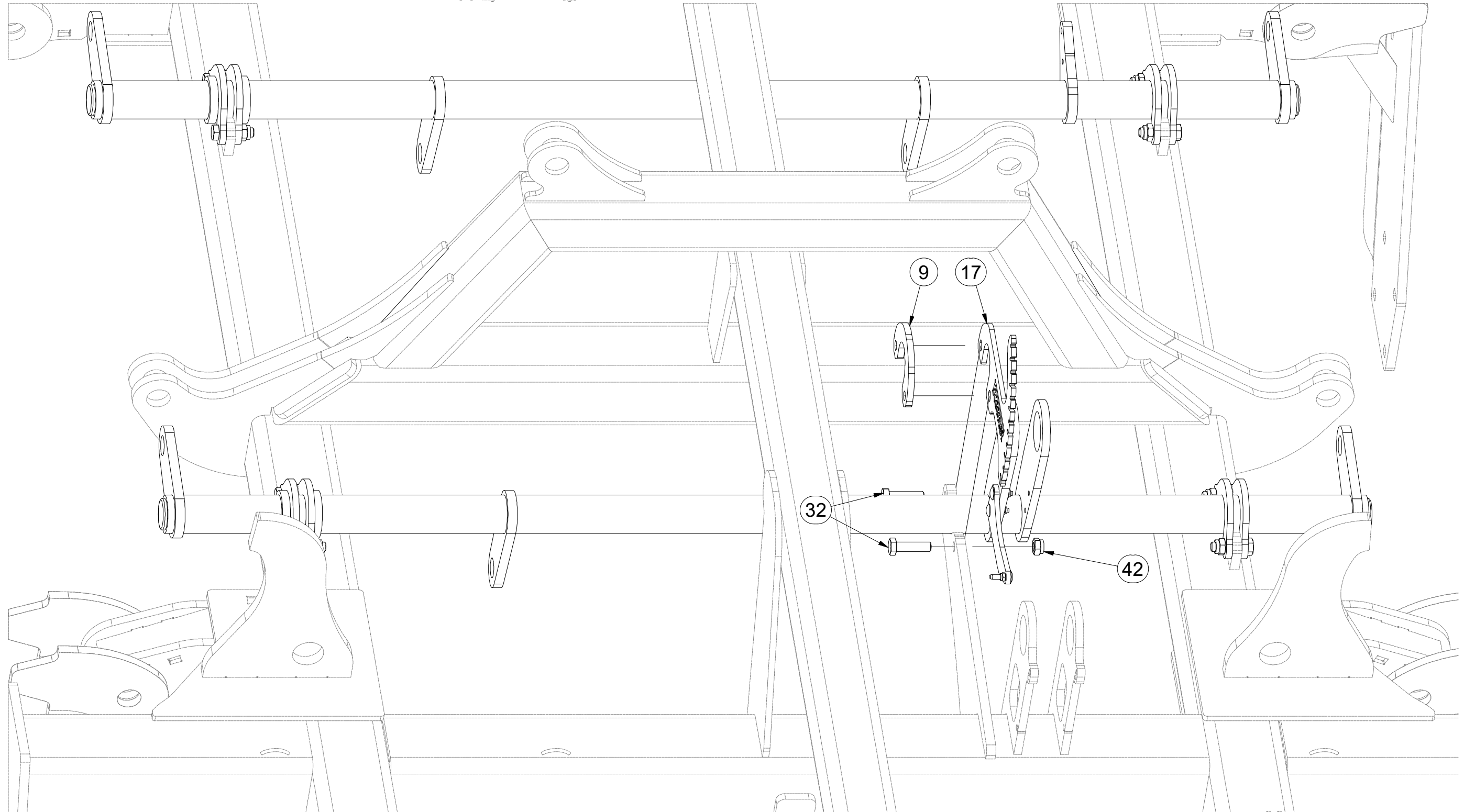

Ⓒ SADA OVLÁDÁNÍ RADLICE

Ⓓ STEUERSATZ PFLUGSCHAR/PFLUGSCHAREN

Ⓕ KIT DE COMMANDE DU SOC/DES SOCS

**VZ00038374**

Ⓖ SET OF PLOUGHSHARE CONTROL

Ⓔ КОМПЛЕКТ УПРАВЛЕНИЯ ЛАПЫ/ЛАП

Ⓗ ZESTAW STEROWANIA REDLIĆA/RADLICAMI

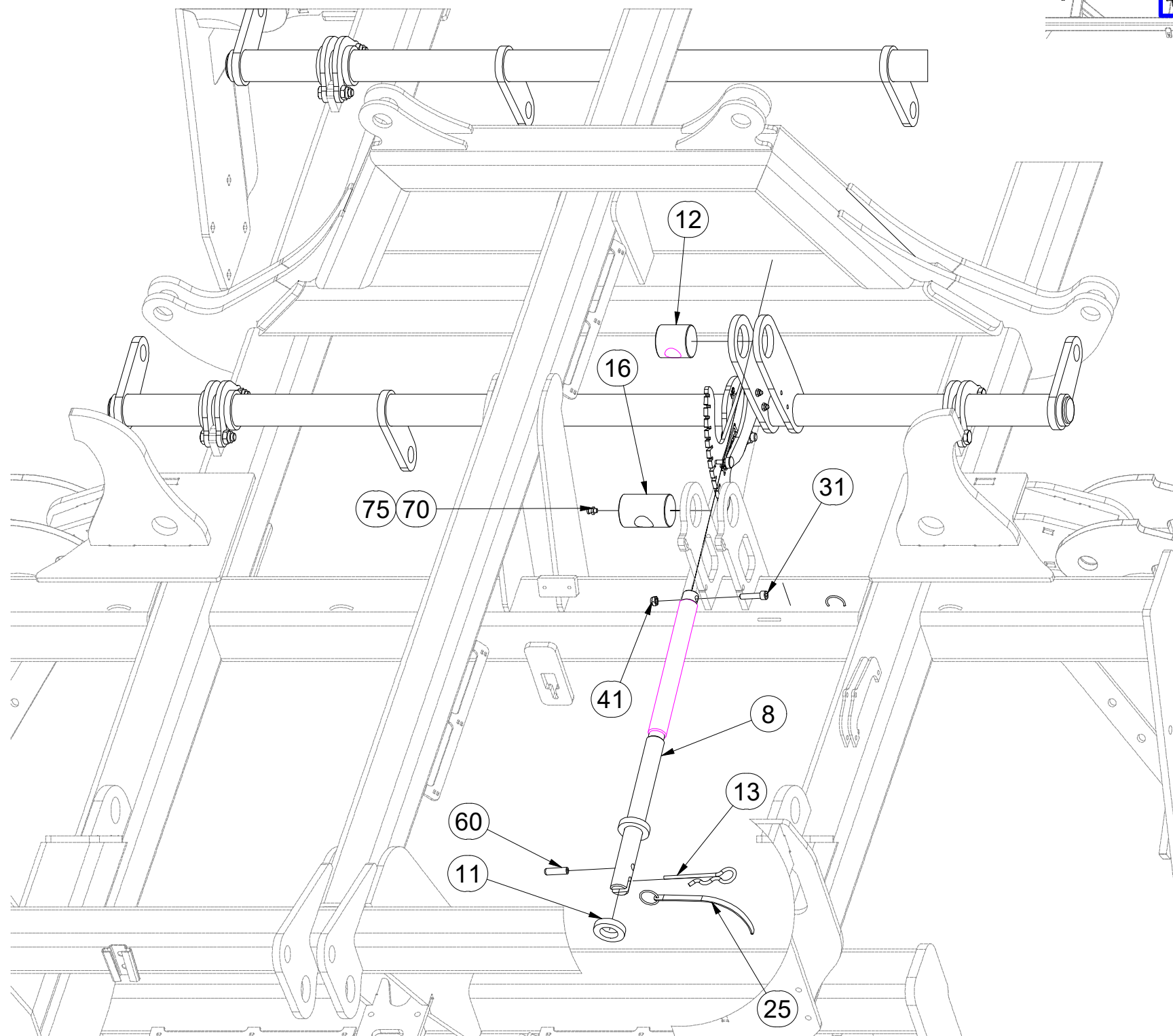
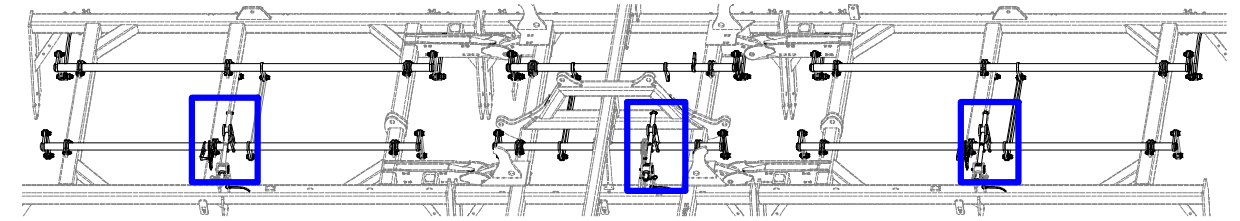

Pos.	Part Number	Pcs.
8	4024250	3
11	9002560	3
12	4005340	3
13	m09988	3
16	9002114	3
25	m12467	3
31	m09464	3
41	m04503	3
60	m10736	3
70	m10451	3
75	m01999	0,100 kg

Ⓒ SADA OVLÁDÁNÍ RADLICE

Ⓓ STEUERSATZ PFLUGSCHAR/PFLUGSCHAREN

Ⓕ KIT DE COMMANDE DU SOC/DES SOCS

Ⓖ SET OF PLOUGHSHARE CONTROL

Ⓡ КОМПЛЕКТ УПРАВЛЕНИЯ ЛАПЫ/ЛАП

Ⓢ ZESTAW STEROWANIA REDLIĆA/RADLICAMI



**VZ00038374**

Pos.	Part Number	Pcs.
5	4005333	24
14	4002265	30
33	m04355	30
43	m03683	46
50	m05651	92

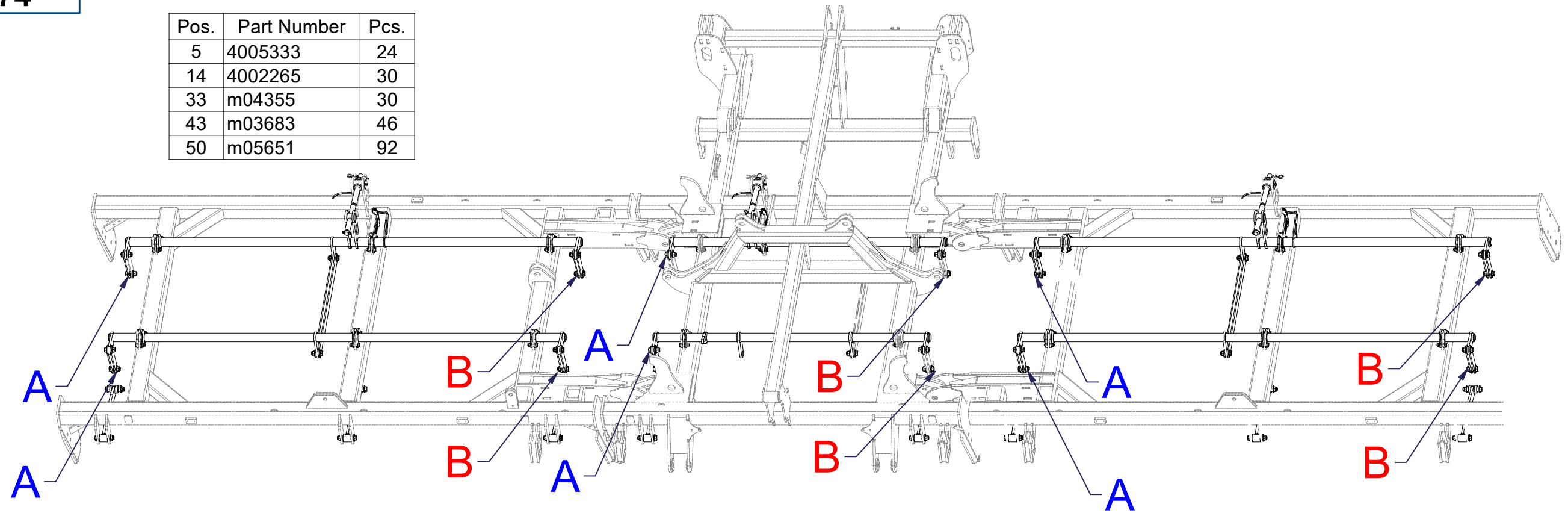

**A**

**B**

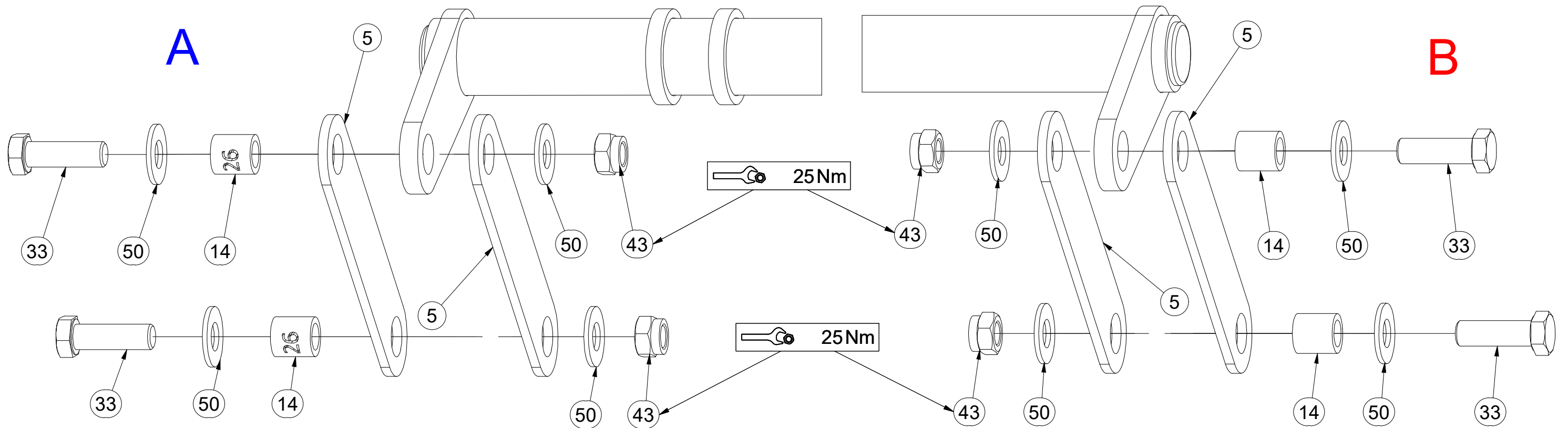

Ⓒ SADA OVLÁDÁNÍ RADLICE

Ⓓ STEUERSATZ PFLUGSCHAR/PFLUGSCHAREN

Ⓕ KIT DE COMMANDE DU SOC/DES SOCS

Ⓖ SET OF PLOUGHSHARE CONTROL

Ⓡ КОМПЛЕКТ УПРАВЛЕНИЯ ЛАПЫ/ЛАП

Ⓟ ZESTAW STEROWANIA REDLIĆA/RADLICAMI



**VZ00038374**

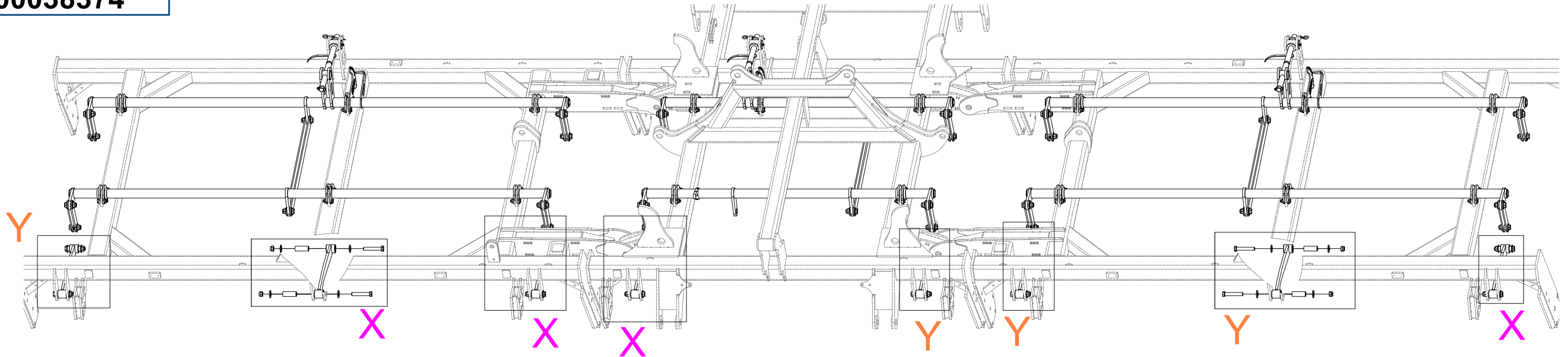

Pos.	Part Number	Pcs.
7	VZ00003342	8
15	9001426	16
34	m07673	16
43	m03683	46
50	m05651	92

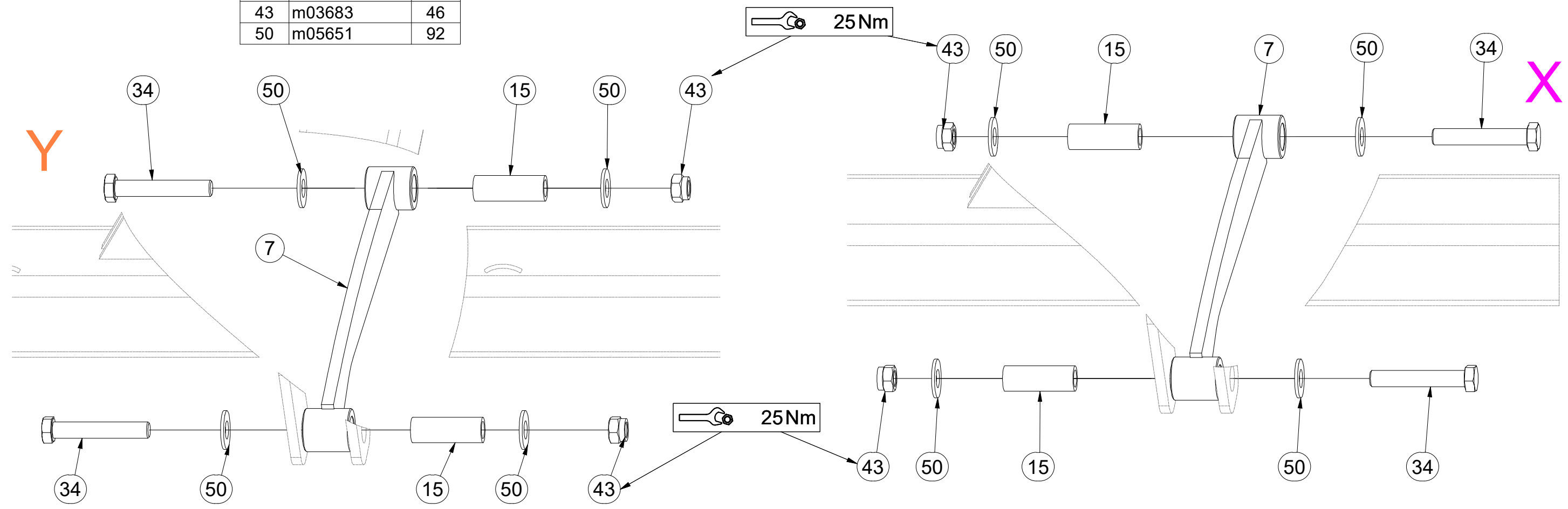

ⒸZ SADA RADLIC

Ⓓ SCHARSATZ

Ⓕ KIT DE SOCS

**VZ00043059**

ⒼB SET OF PLOUGHSHARES

ⒺU КОМПЛЕКТ ЛАП

ⒽL ZESTAW REDLIC

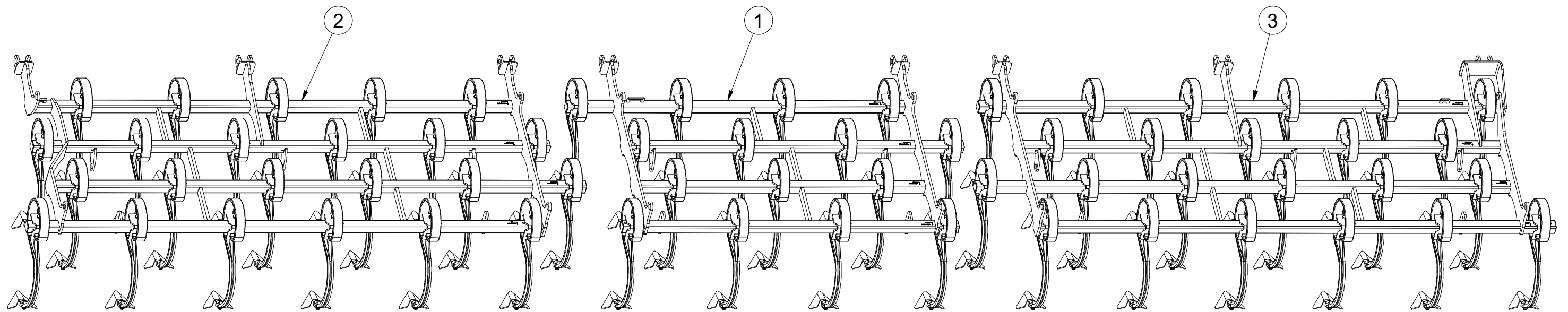

Pos.	Part Number	Pcs.
1	VZ00037601	1
2	VZ00042811	1
3	VZ00042813	1

CZ STŘEDNÍ RÁM  
 D RAHMEN, MITTLERE  
 F CHASSIS CENTRAL

GB CENTRAL FRAME  
 RU СРЕДНЯЯ РАМА  
 PL SREDNIA RAMA



**VZ00037601**

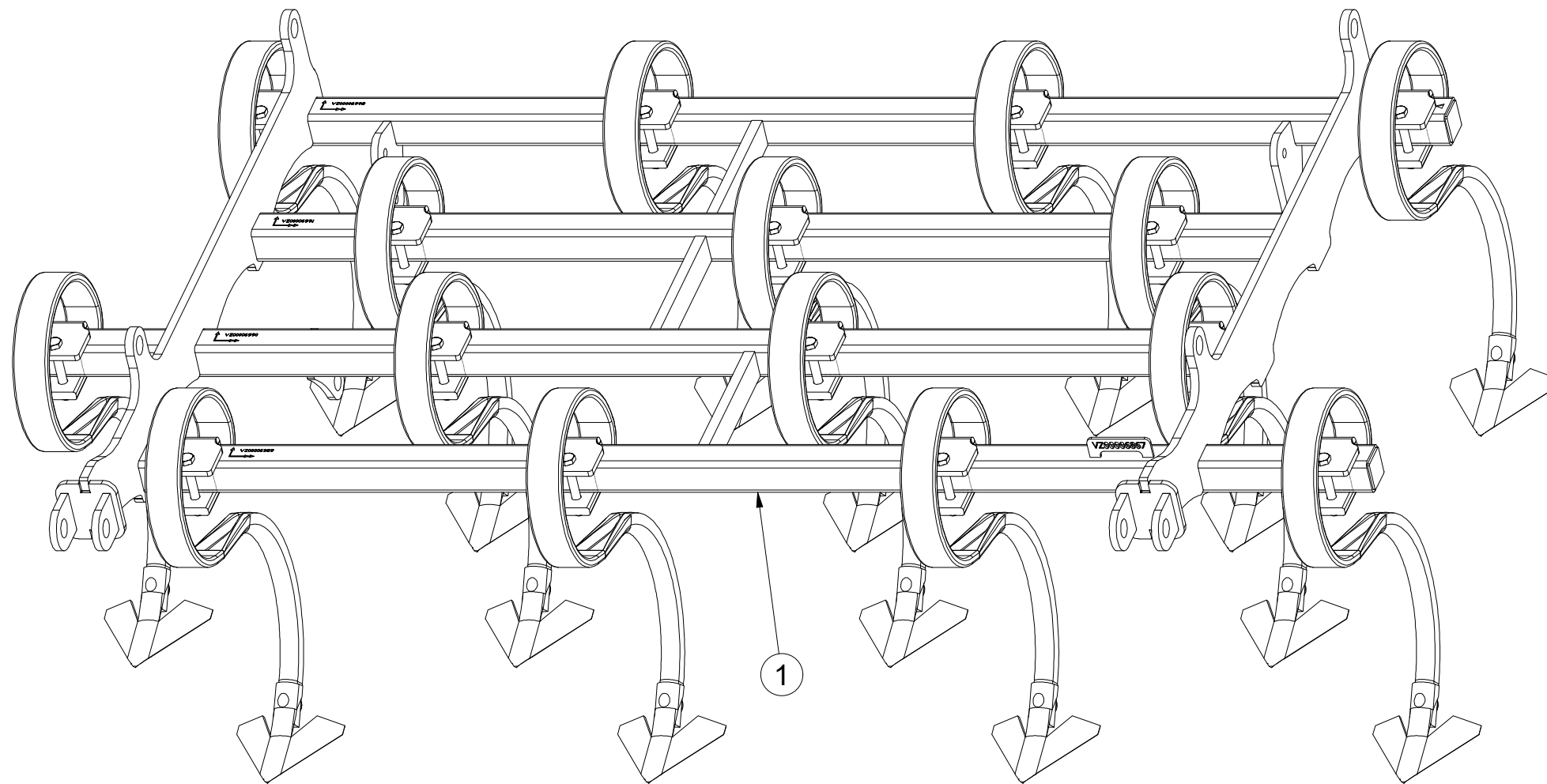
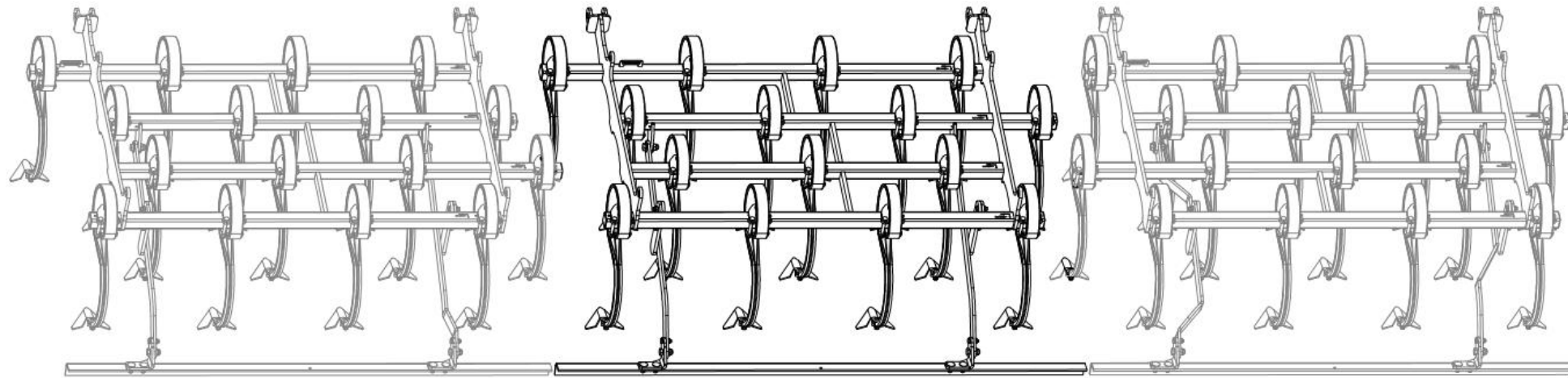

Pos.	Part Number	Pcs.
1	VZ00006867	1



Ⓒ STŘEDNÍ RÁM

Ⓓ RAHMEN, MITTLERE

Ⓕ CHASSIS CENTRAL

Ⓒ CENTRAL FRAME

Ⓓ СРЕДНЯЯ РАМА

Ⓕ SREDNIA RAMA



**VZ00037601**

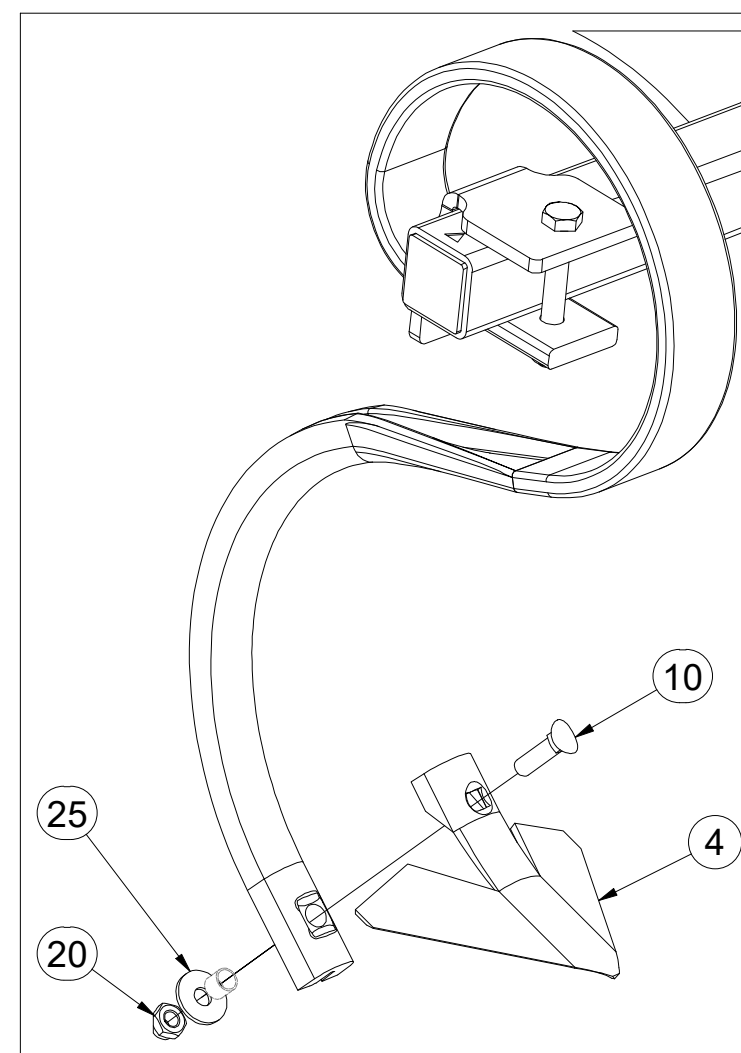
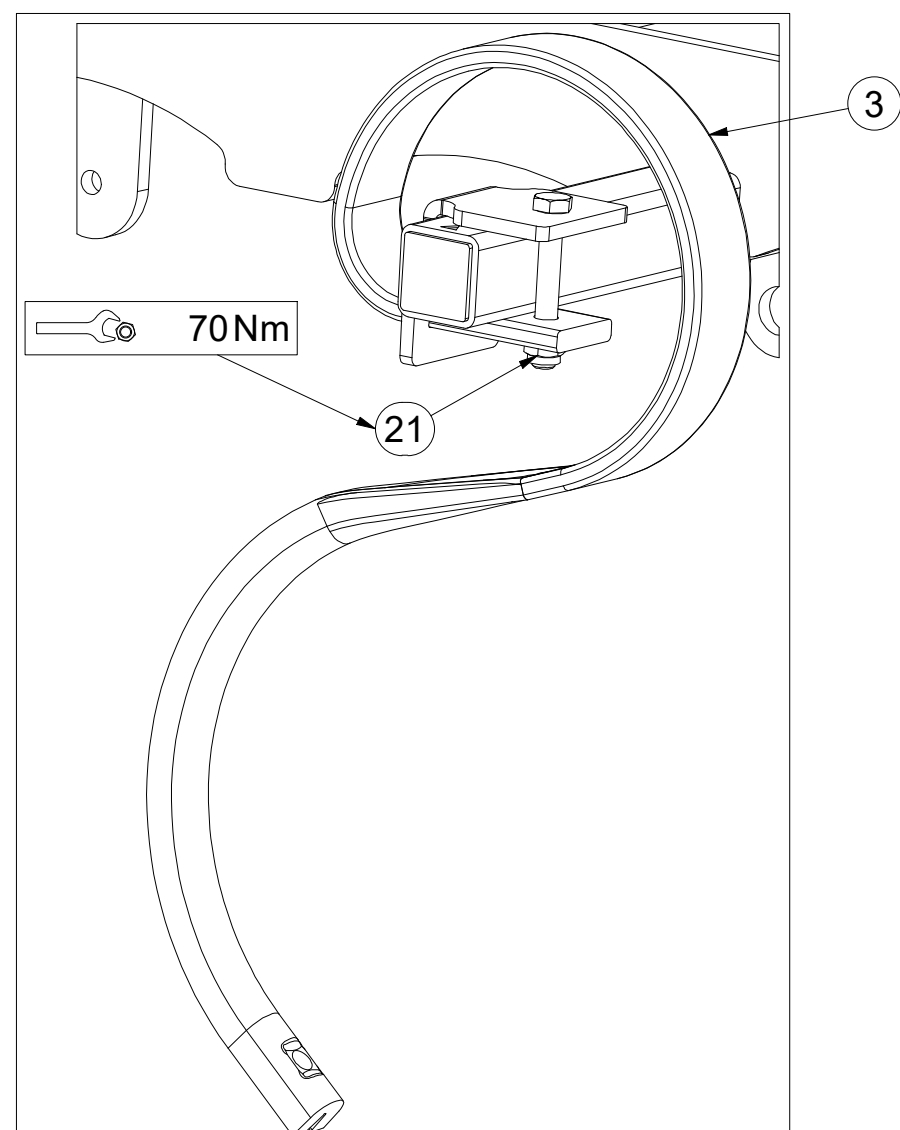
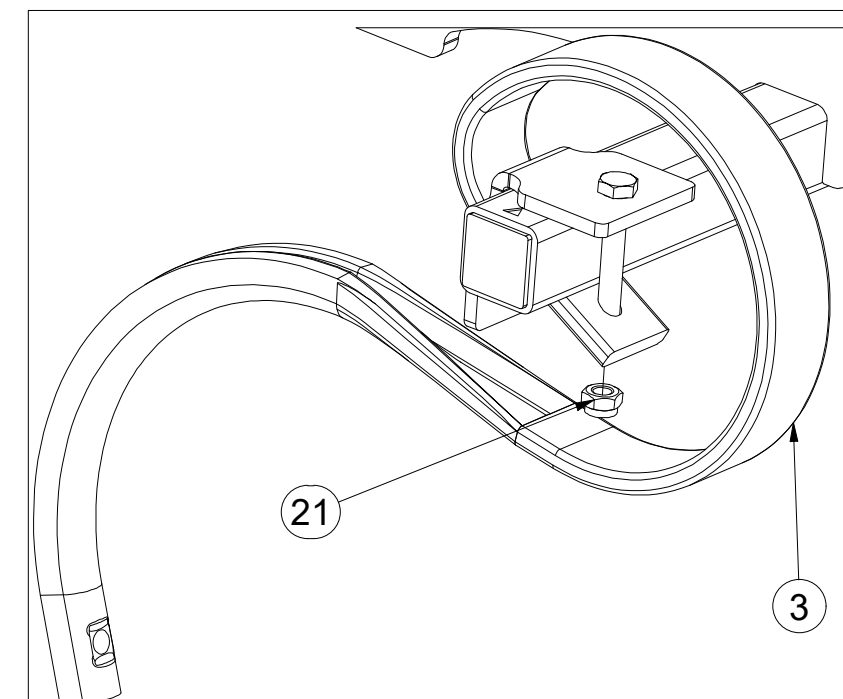
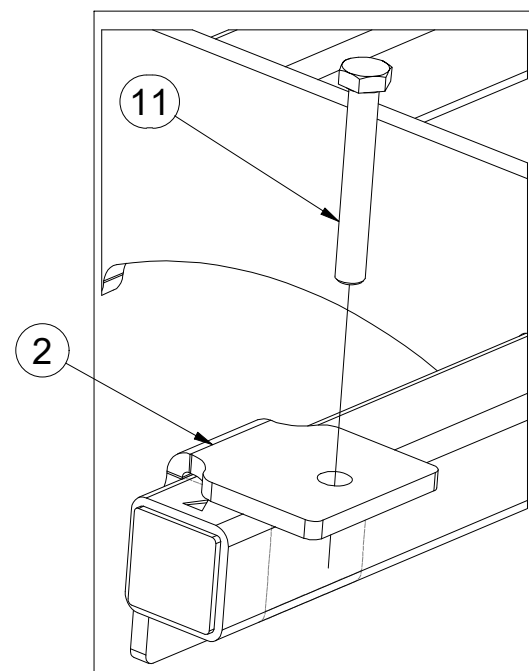

Pos.	Part Number	Pcs.
2	VZ00037383	15
3	VZ00006979	15
4	VZ00006975	15
10	m20483	15
11	m11904	15
20	m03775	15
21	m21001	15
25	m16981	15

Ⓒ RÁM LEVÝ  
Ⓓ LINKER RAHMEN  
Ⓕ CHASSIS GAUCHE

Ⓖ LEFT FRAME  
Ⓡ РАМА ЛЕВАЯ  
Ⓟ RAMA LEWA



**VZ00042811**

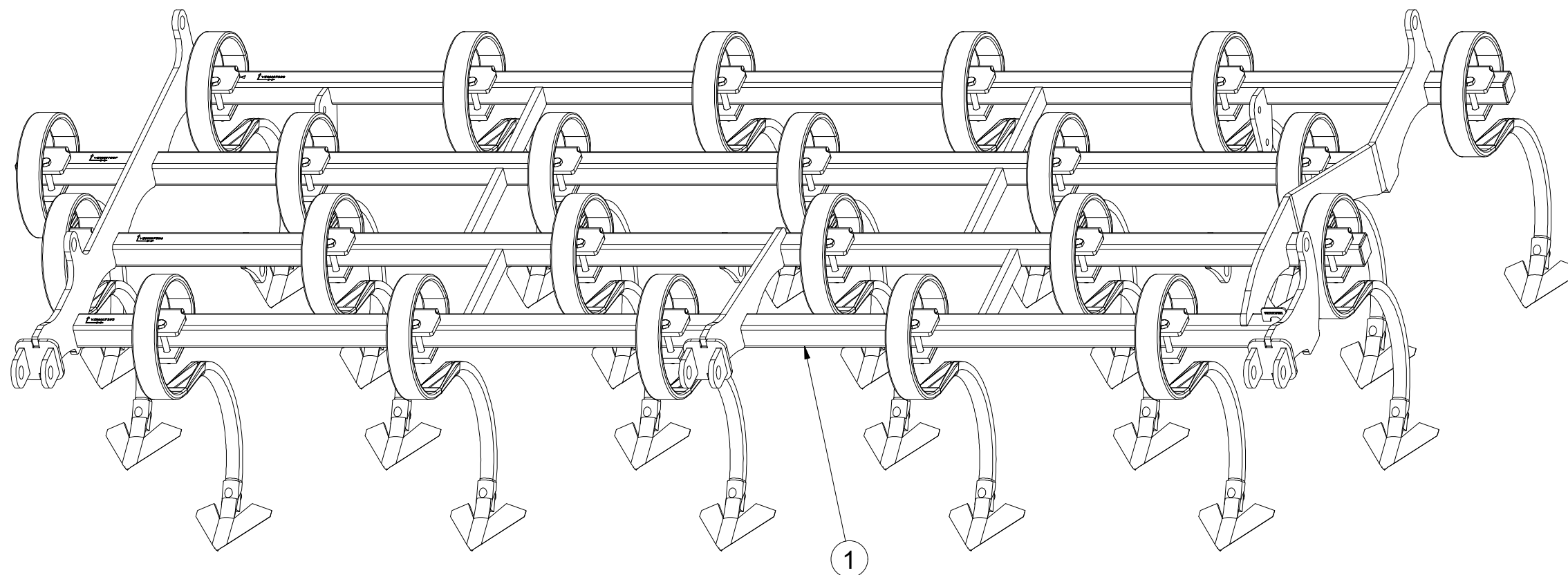
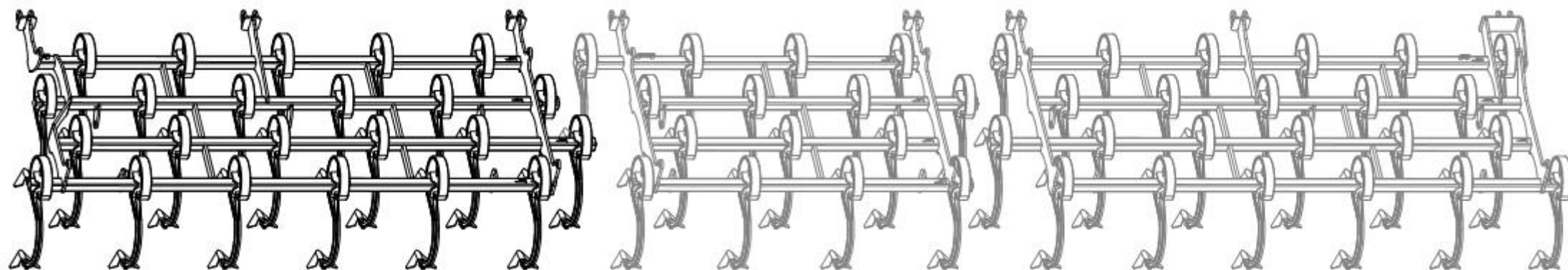

Pos.	Part Number	Pcs.
1	VZ00007381	1

- Ⓒ RÁM LEVÝ
- Ⓓ LINKER RAHMEN
- Ⓕ CHASSIS GAUCHE

- Ⓖ LEFT FRAME
- Ⓡ РАМА ЛЕВАЯ
- Ⓟ RAMA LEWA



**VZ00042811**

Pos.	Part Number	Pcs.
2	VZ00006979	23
3	VZ00006975	23
4	VZ00037383	23
10	m20483	23
11	m11904	23
15	m03775	23
16	m21001	23
20	m16981	23

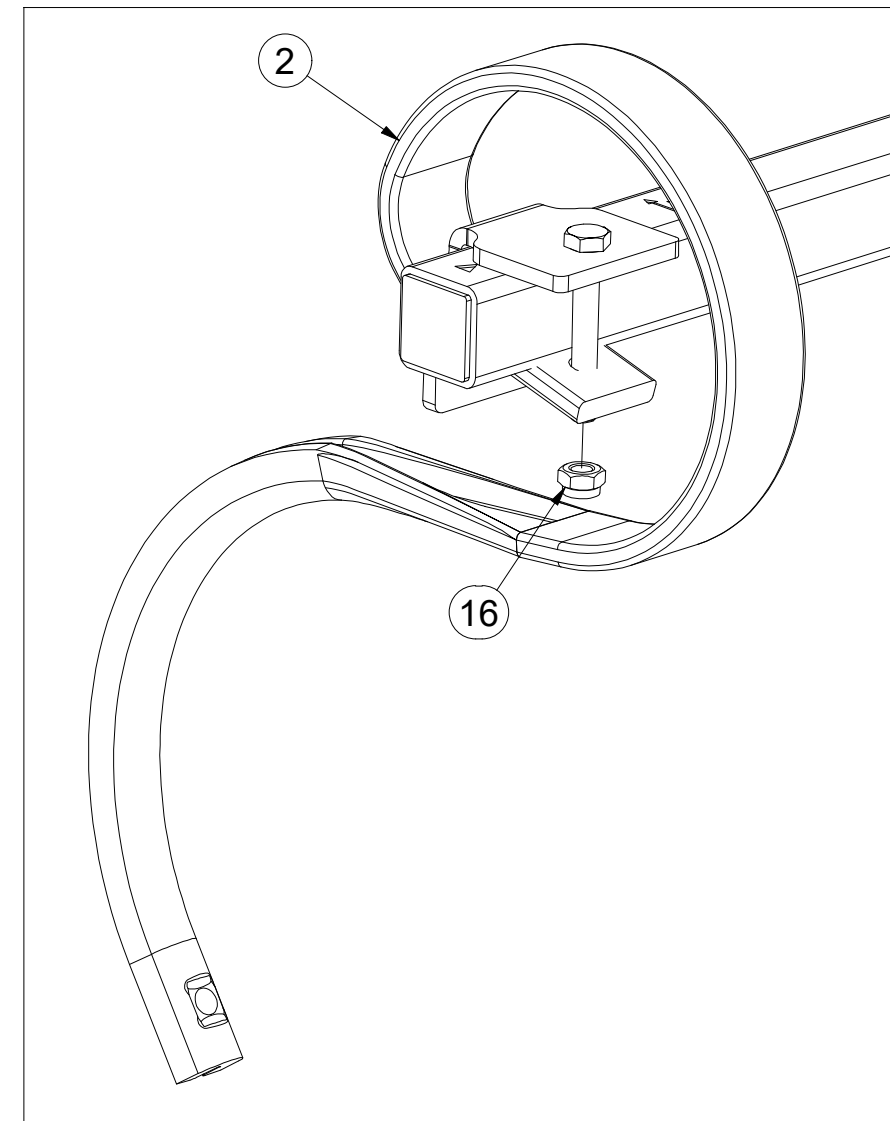
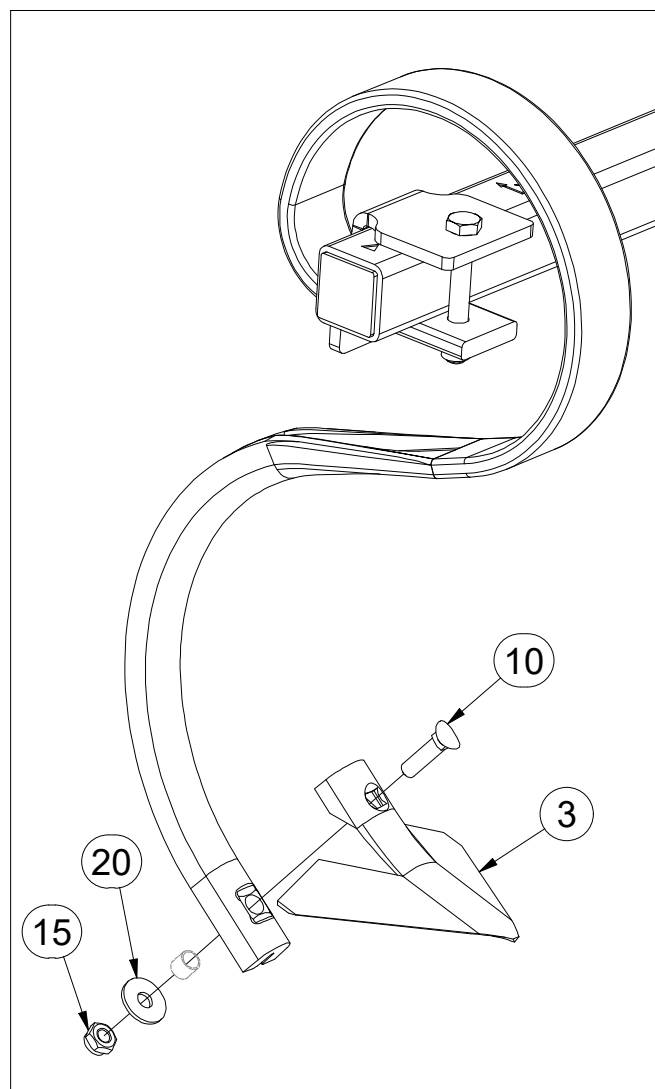
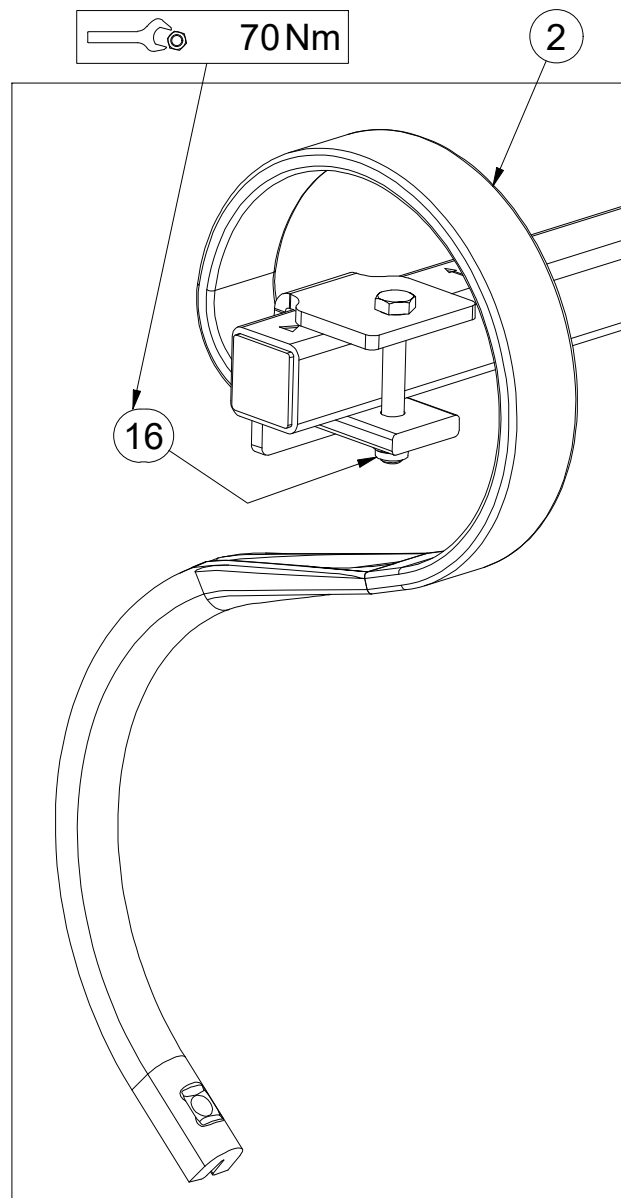
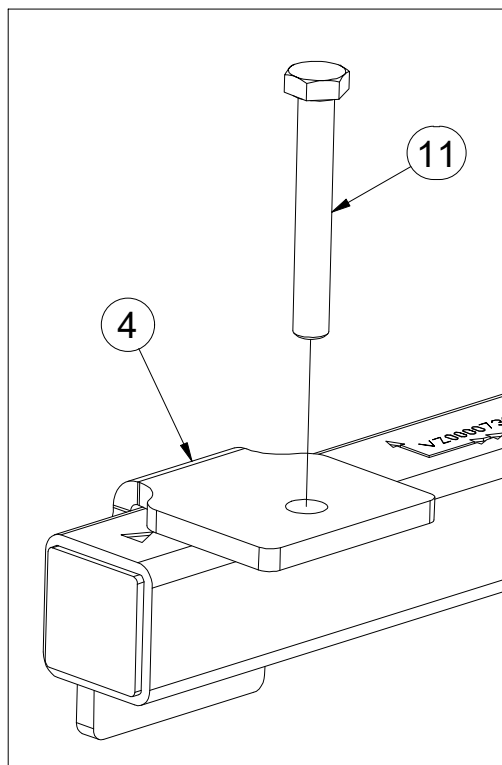

ⒸZ RÁM PRAVÝ  
Ⓓ RECHTER RAHMEN  
Ⓕ CHASSIS DROIT

ⒸB RIGHT FRAME  
ⒹU PAMA ПРАВАЯ  
ⒸL RAMA PRAWA



**VZ00042813**

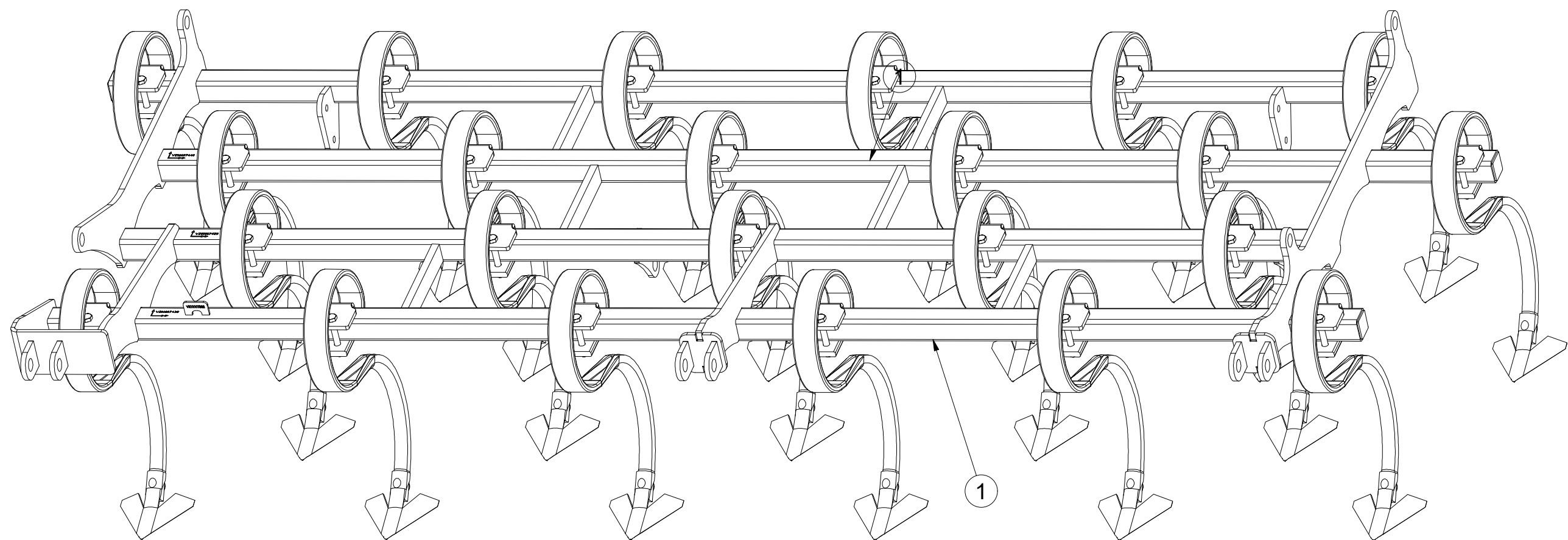
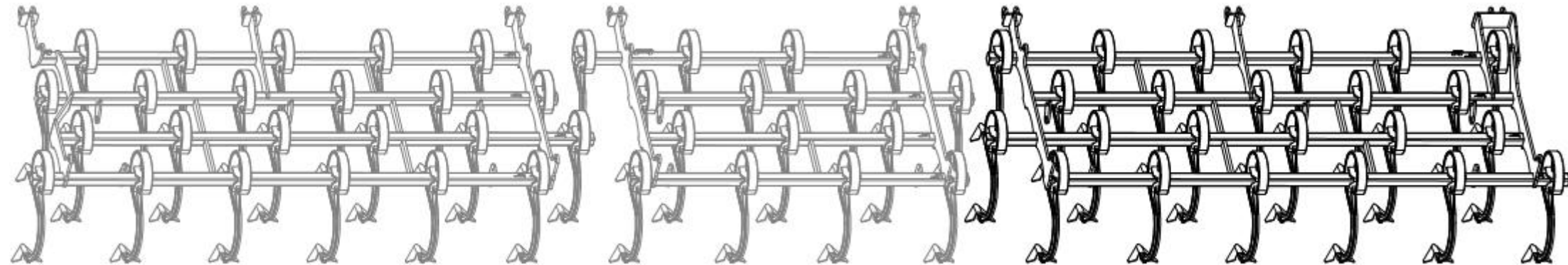

Pos.	Part Number	Pcs.
1	VZ00007382	1

Ⓒ RÁM PRAVÝ

Ⓓ RECHTER RAHMEN

Ⓕ CHASSIS DROIT

Ⓖ RIGHT FRAME

Ⓡ РАМА ПРАВАЯ

Ⓢ RAMA PRAWA



**VZ00042813**

Pos.	Part Number	Pcs.
2	VZ00006975	23
3	VZ00006979	23
4	VZ00037383	23
10	m20483	23
11	m11904	23
15	m03775	23
16	m21001	23
20	m16981	23

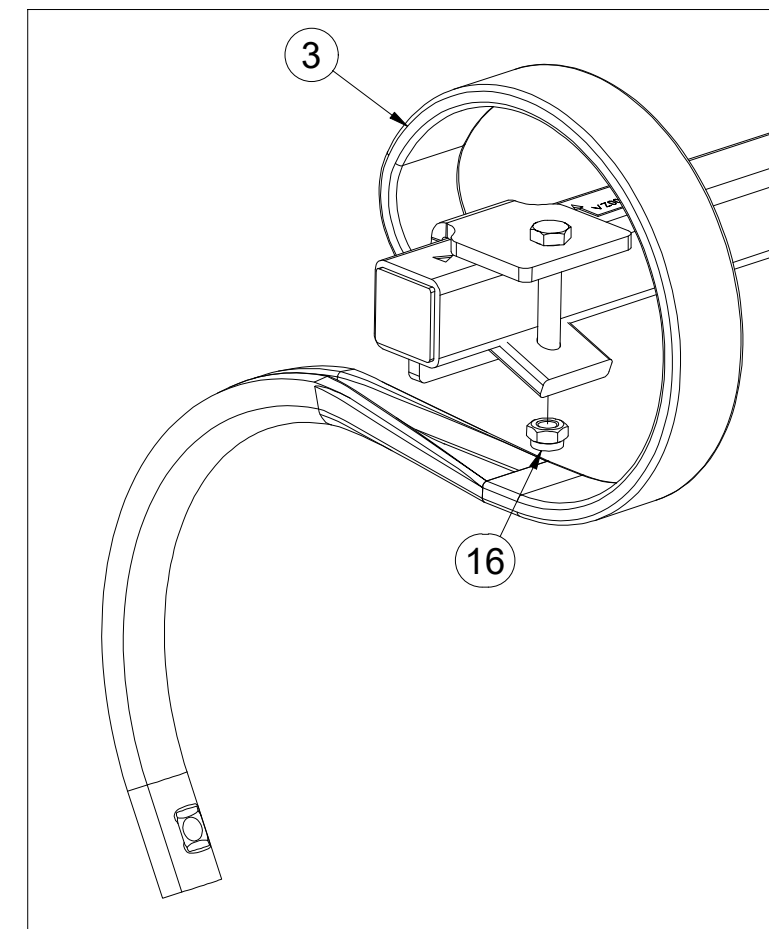
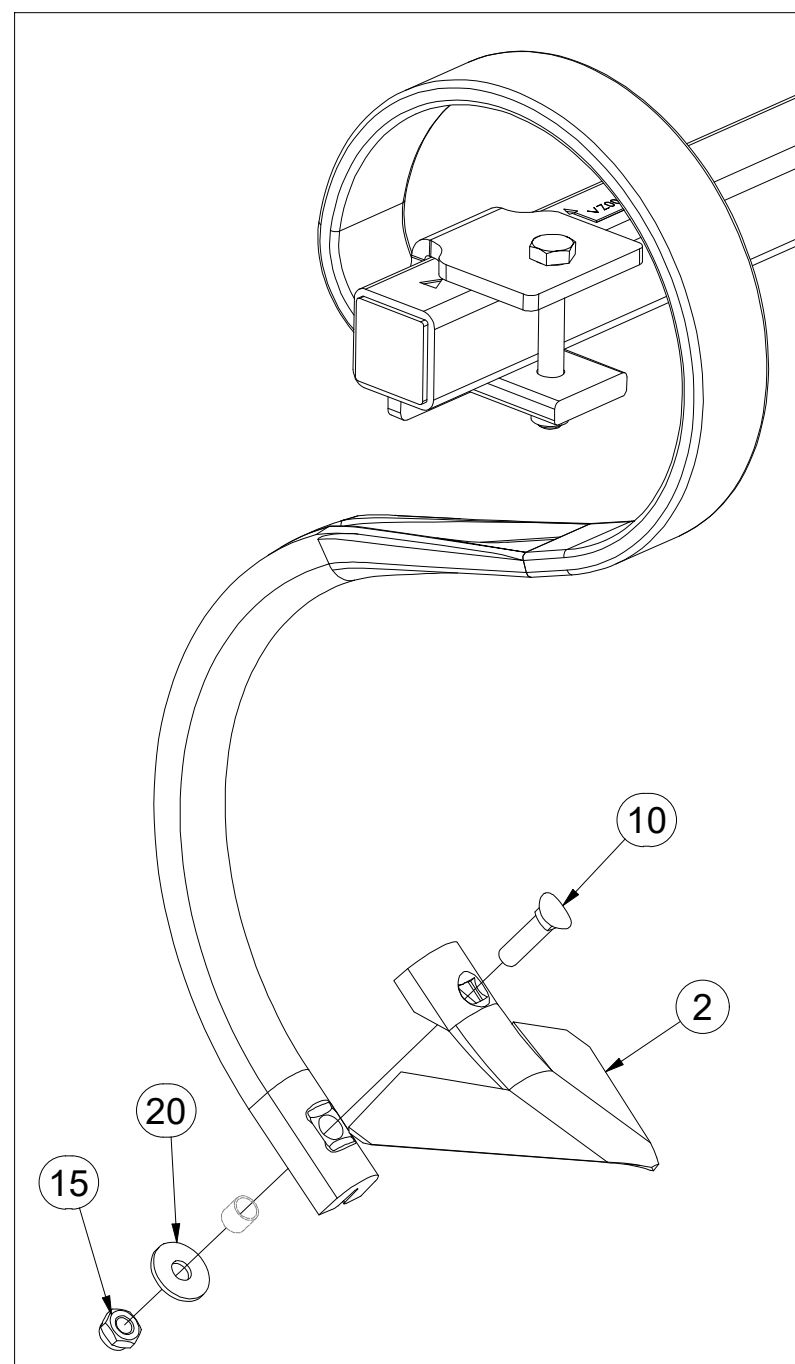
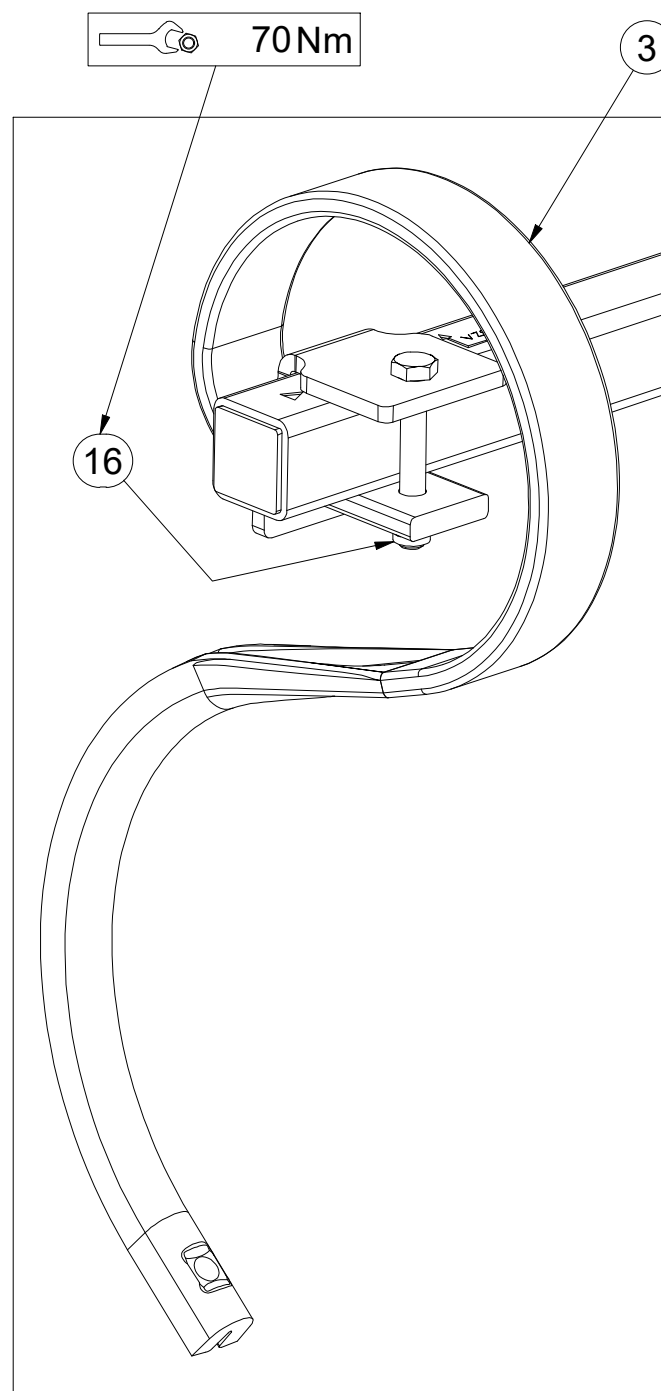
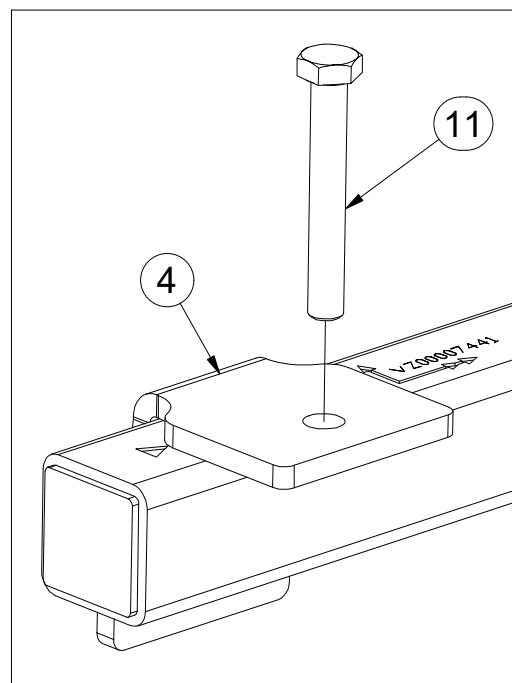

ⒸZ SADA SMYKŮ RADLIC

Ⓓ SATZ SCHARSCHLEPPEN

Ⓕ KIT DE NIVELEURS DES SOCS

**VZ00043060**

ⒼB SET OF PLOUGHSHARE LEVELLING BARS

ⒺU КОМПЛЕКТ БОРОН ЛАП

ⒽL ZESTAW WŁÓK REDLIC

**Farmet**

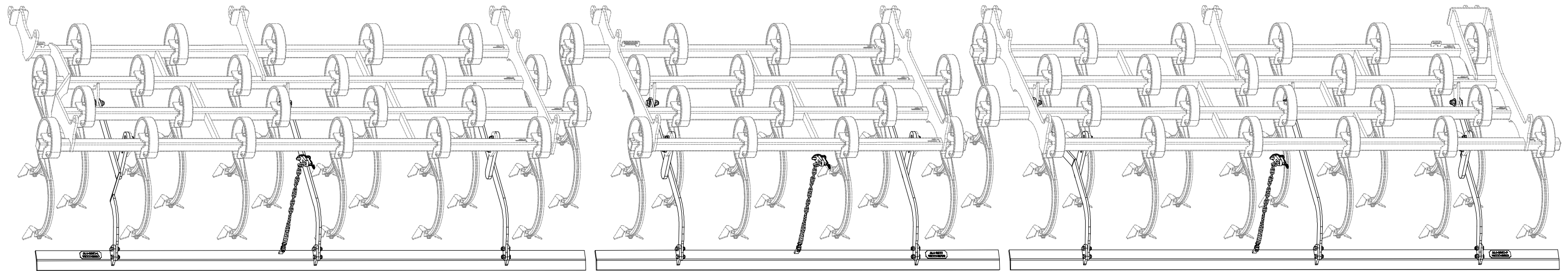

ⒸZ SADA SMYKŮ RADLIC

Ⓓ SATZ SCHARSCHLEPPEN

Ⓕ KIT DE NIVELEURS DES SOCS

ⒼB SET OF PLOUGHSHARE LEVELLING BARS

ⒺU КОМПЛЕКТ БОРОН ЛАП

ⒽL ZESTAW WŁÓK REDLIC



**VZ00043060**

Pos.	Part Number	Pcs.
7	VZ00042797	5
8	VZ00042814	1
12	4022223	8
23	m04355	8
32	m03683	8
41	m05651	16

1.

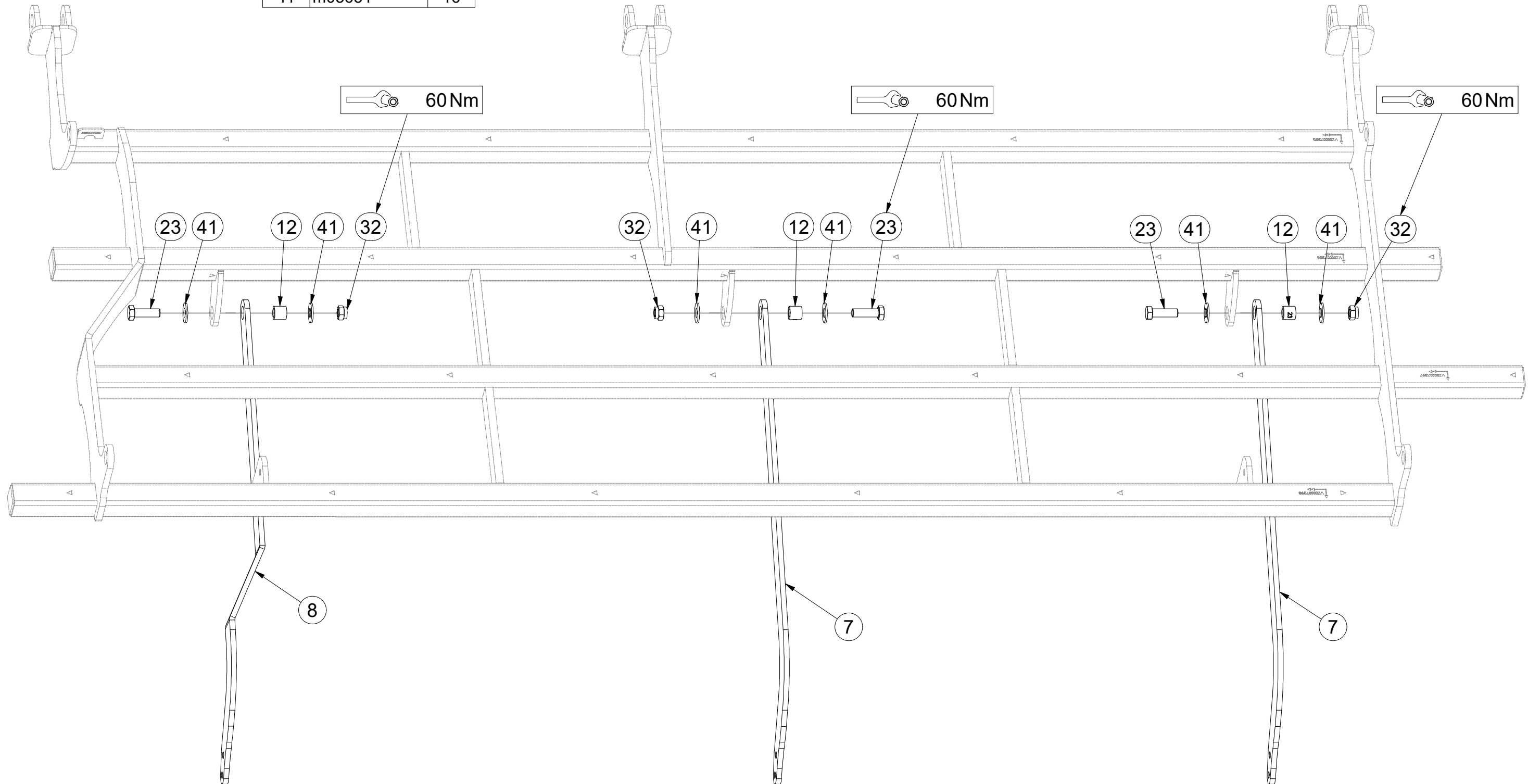
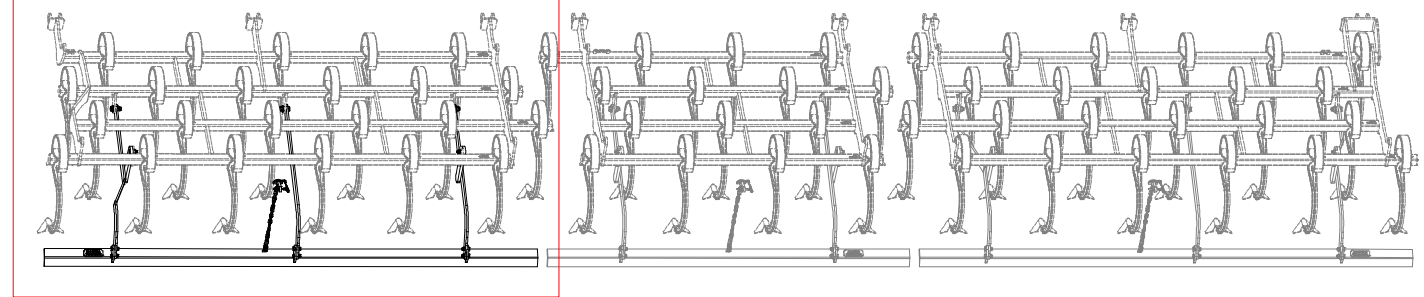

Ⓒ SADA SMYKŮ RADLIC

Ⓓ SATZ SCHARSCHLEPPEN

Ⓕ KIT DE NIVELEURS DES SOCS

Ⓖ SET OF PLOUGHSHARE LEVELLING BARS

Ⓡ КОМПЛЕКТ БОРОН ЛАП

Ⓟ ZESTAW WŁÓK REDLIC



VZ00043060

2.

Pos.	Part Number	Pcs.
7	VZ00042797	5
8	VZ00042814	1
11	VZ00042831	6
22	m02491	12
31	m04301	28

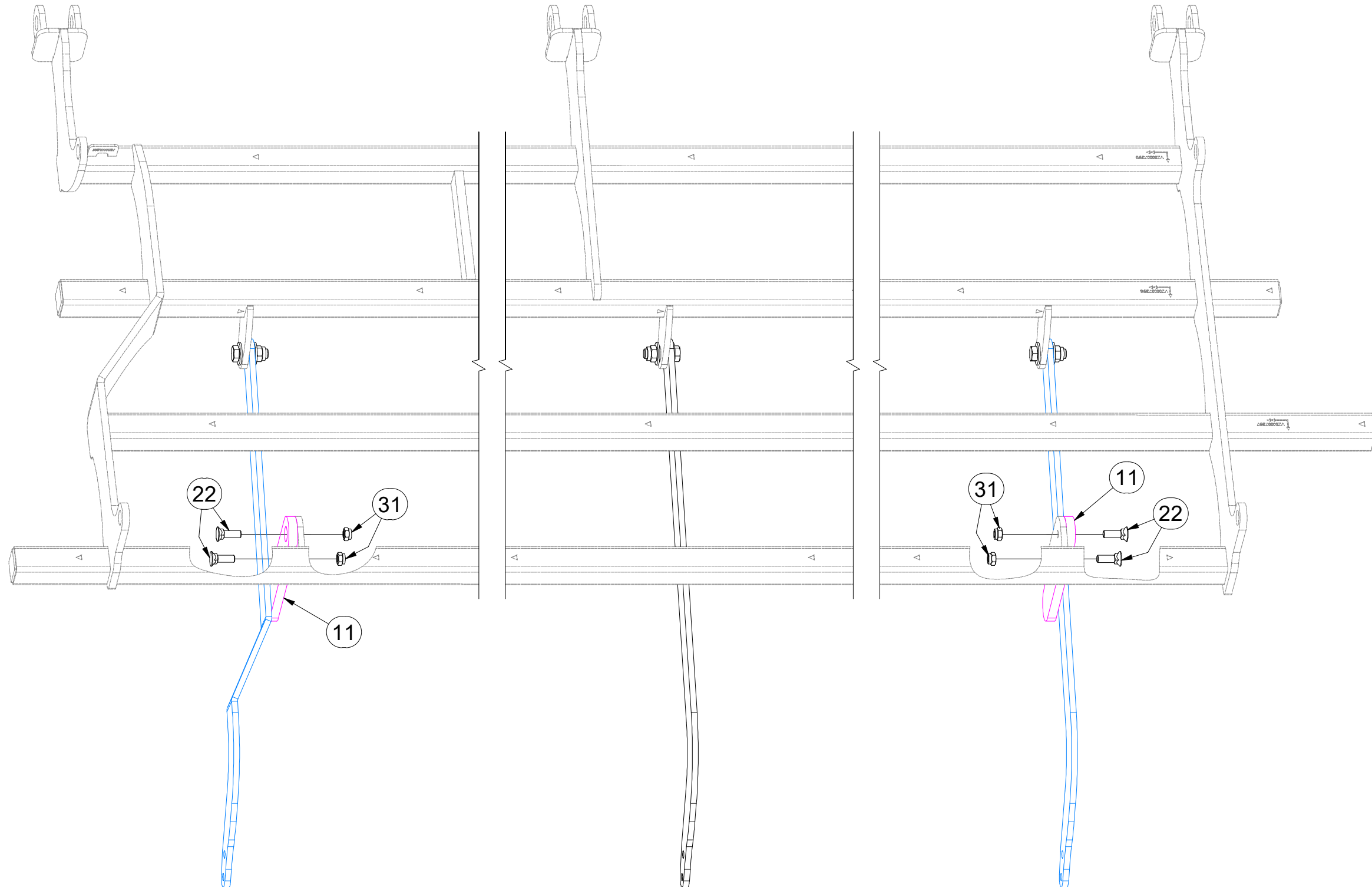
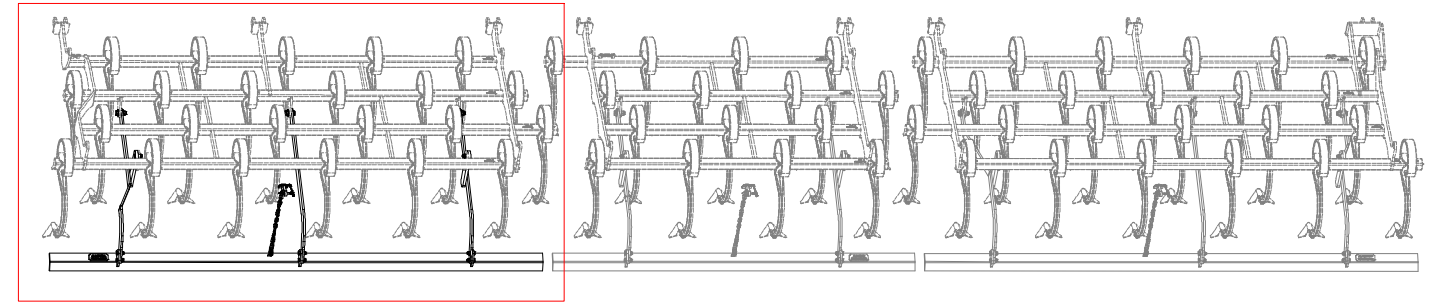



- Ⓒ SADA SMYKŮ RADLIC
- Ⓓ SATZ SCHARSCHLEPPEN
- Ⓕ KIT DE NIVELEURS DES SOCS

- Ⓖ SET OF PLOUGHSHARE LEVELLING BARS
- Ⓡ КОМПЛЕКТ БОРОН ЛАП
- Ⓟ ZESTAW WŁÓK REDLIC



**VZ00043060**

1.

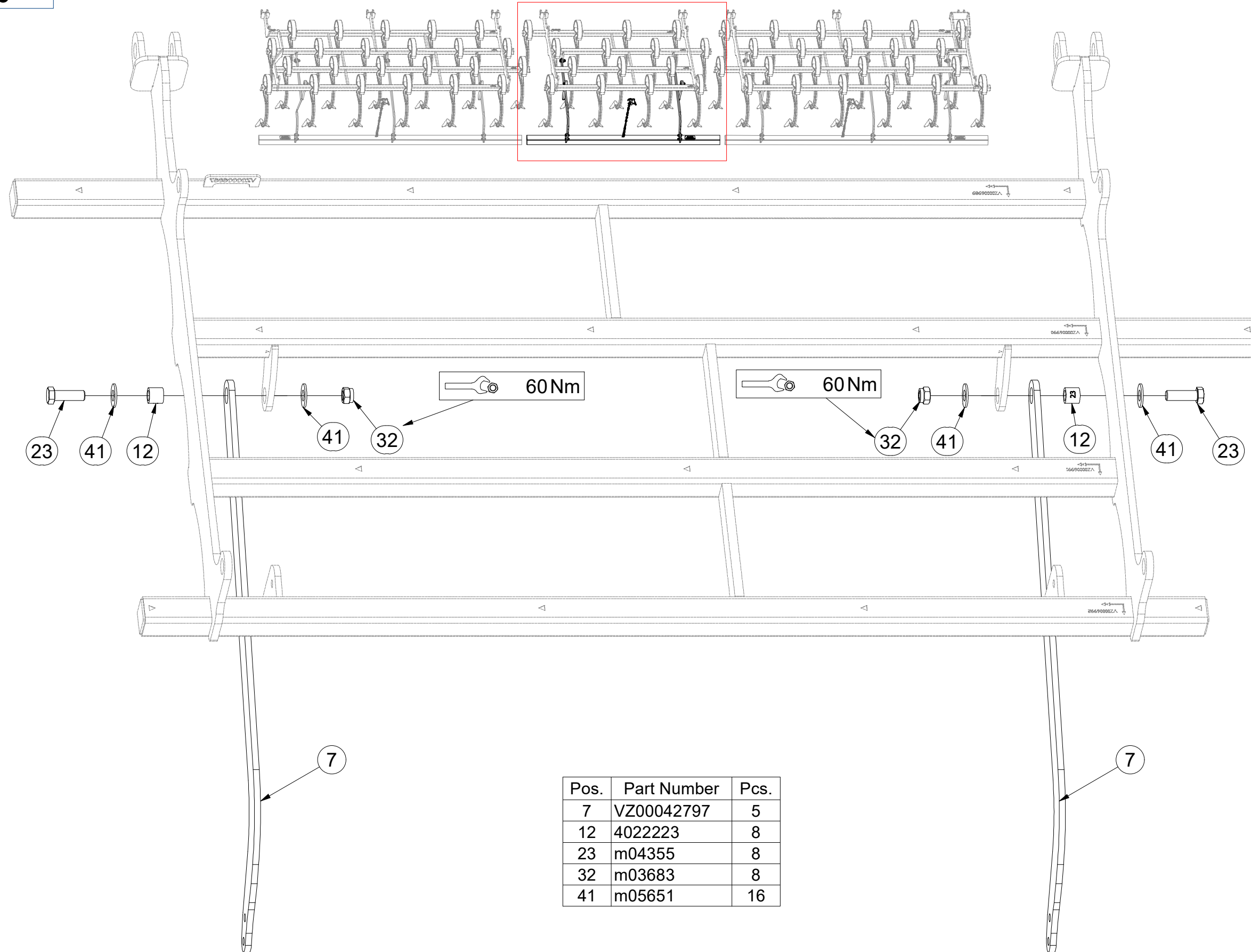

Pos.	Part Number	Pcs.
7	VZ00042797	5
12	4022223	8
23	m04355	8
32	m03683	8
41	m05651	16

- Ⓒ SADA SMYKŮ RADLIC
- Ⓓ SATZ SCHARSCHLEPPEN
- Ⓕ KIT DE NIVELEURS DES SOCS

- Ⓖ SET OF PLOUGHSHARE LEVELLING BARS
- Ⓡ КОМПЛЕКТ БОРОН ЛАП
- Ⓟ ZESTAW WŁÓK REDLIC



VZ00043060

2.

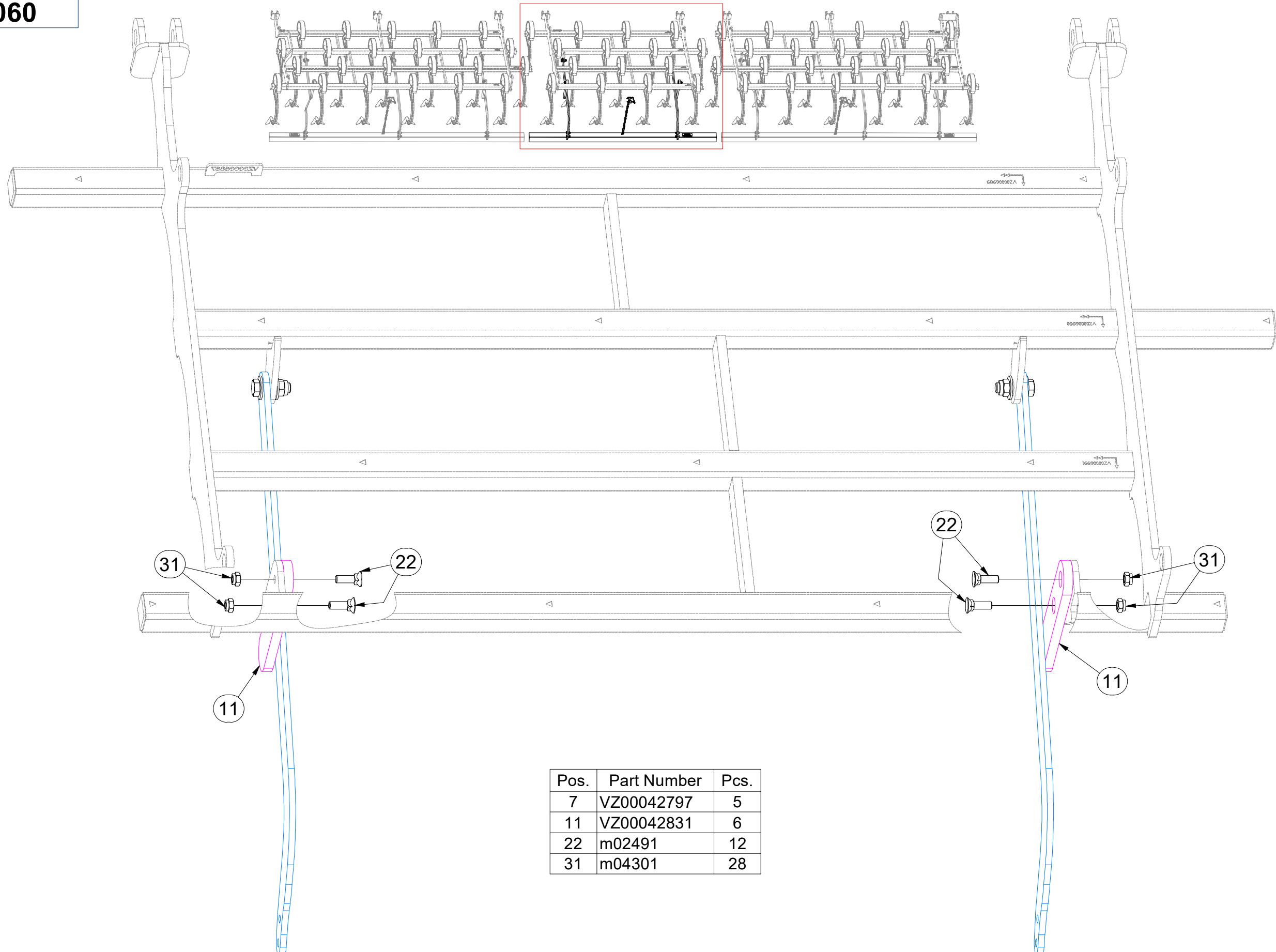

Pos.	Part Number	Pcs.
7	VZ00042797	5
11	VZ00042831	6
22	m02491	12
31	m04301	28

ⒸZ SADA SMYKŮ RADLIC

Ⓓ SATZ SCHARSCHLEPPEN

Ⓕ KIT DE NIVELEURS DES SOCS

ⒸB SET OF PLOUGHSHARE LEVELLING BARS

ⒸU КОМПЛЕКТ БОРОН ЛАП

ⒸL ZESTAW WŁÓK REDLIC



**VZ00043060**

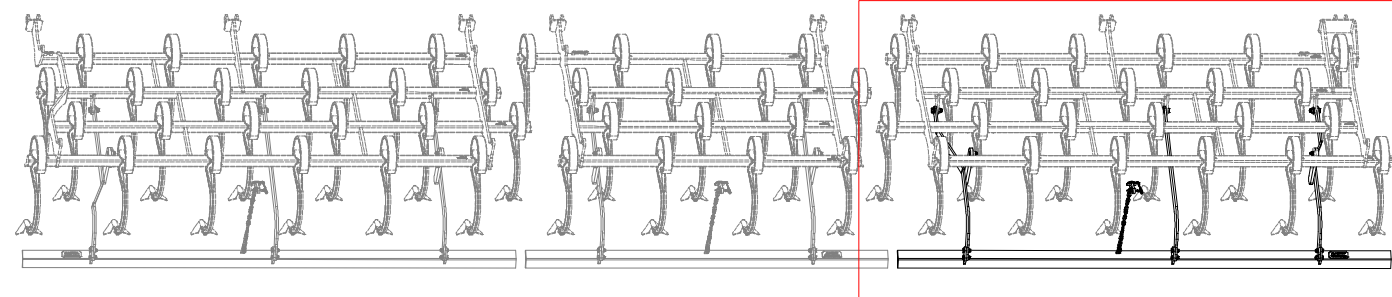

Pos.	Part Number	Pcs.
7	VZ00042797	5
9	VZ00042817	1
10	VZ00042815	1
11	VZ00042831	6
12	4022223	8
22	m02491	12
23	m04355	8
31	m04301	28
32	m03683	8
41	m05651	16

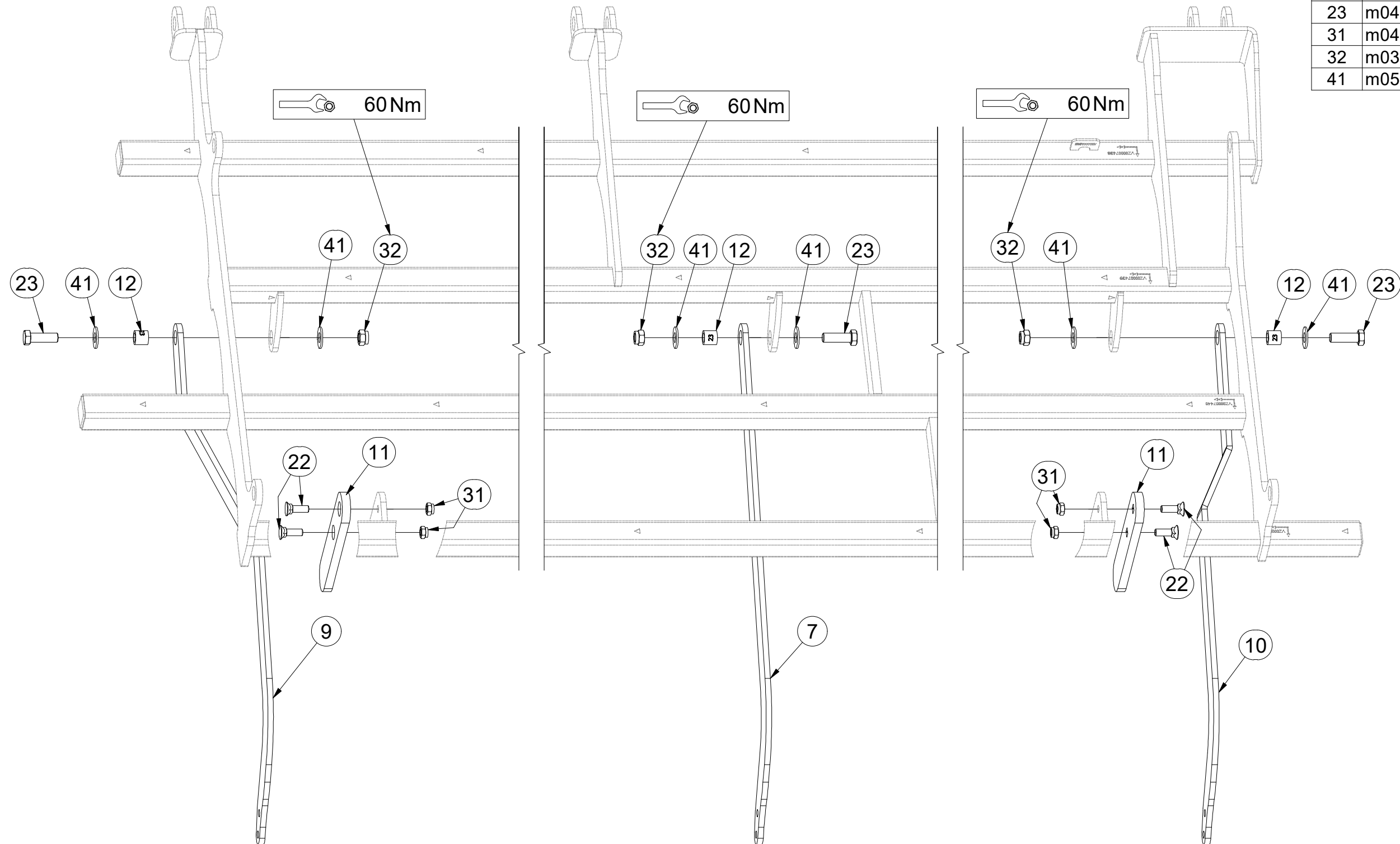

Ⓒ CZ SADA SMYKŮ RADLIC

Ⓓ SATZ SCHARSCHLEPPEN

Ⓕ KIT DE NIVELEURS DES SOCS

Ⓖ GB SET OF PLOUGHSHARE LEVELLING BARS

Ⓡ RU КОМПЛЕКТ БОРОН ЛАП

Ⓟ PL ZESTAW WŁÓK REDLIC



**VZ00043060**

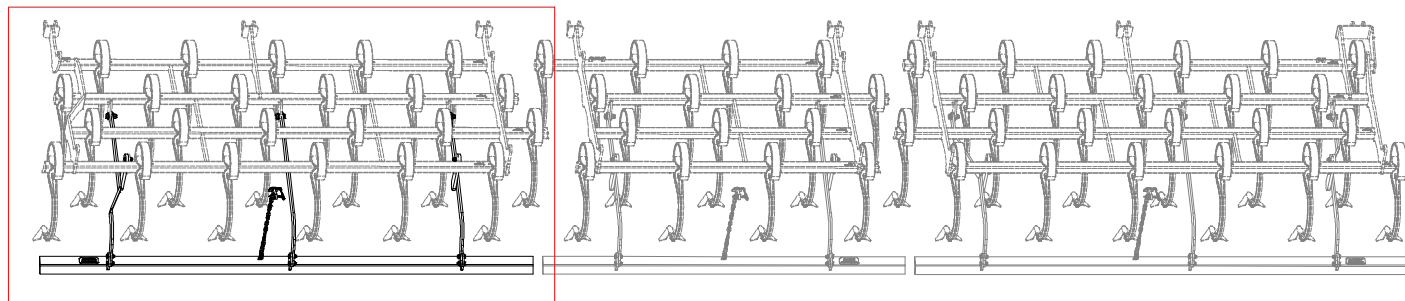

Pos.	Part Number	Pcs.
5	VZ00042810	1
21	m04343	16
31	m04301	28

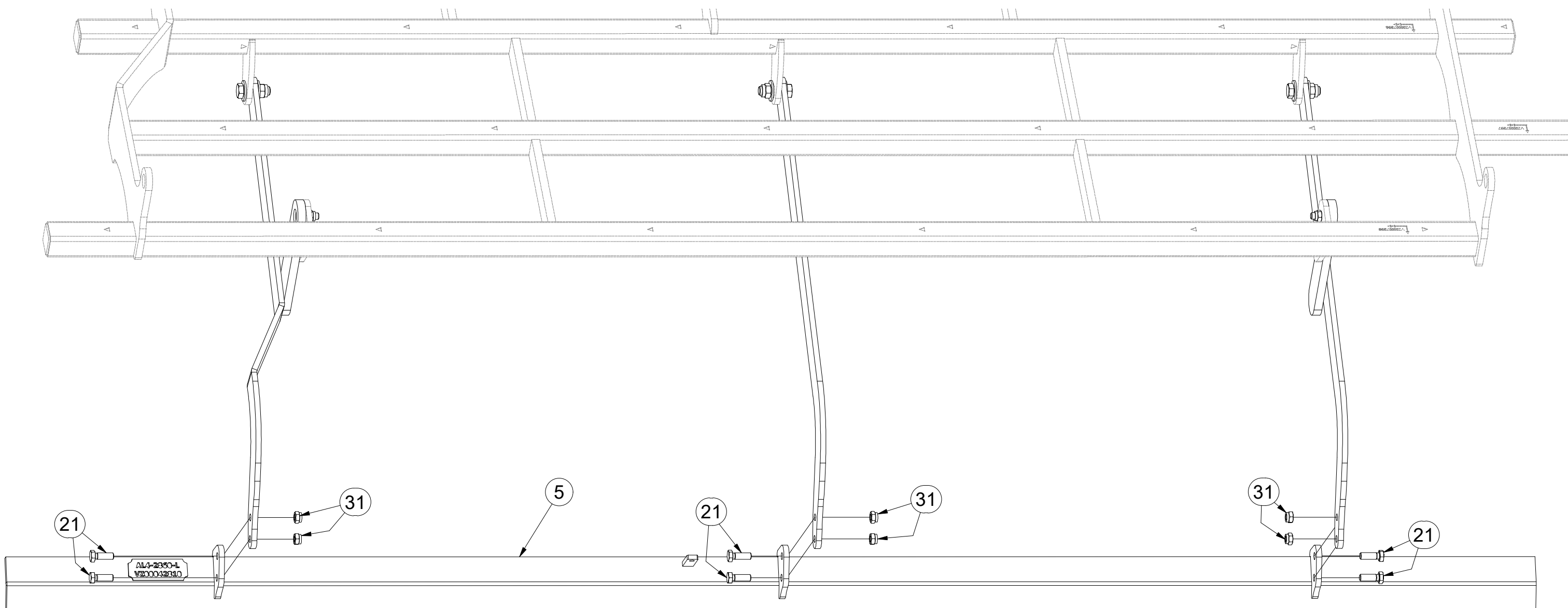

ⒸZ SADA SMYKŮ RADLIC

Ⓓ SATZ SCHARSCHLEPPEN

Ⓕ KIT DE NIVELEURS DES SOCS

ⒸGB SET OF PLOUGHSHARE LEVELLING BARS

ⒸRU КОМПЛЕКТ БОРОН ЛАП

ⒸPL ZESTAW WŁÓK REDLIC



**VZ00043060**

Pos.	Part Number	Pcs.
4	VZ00042798	1
21	m04343	16
31	m04301	28

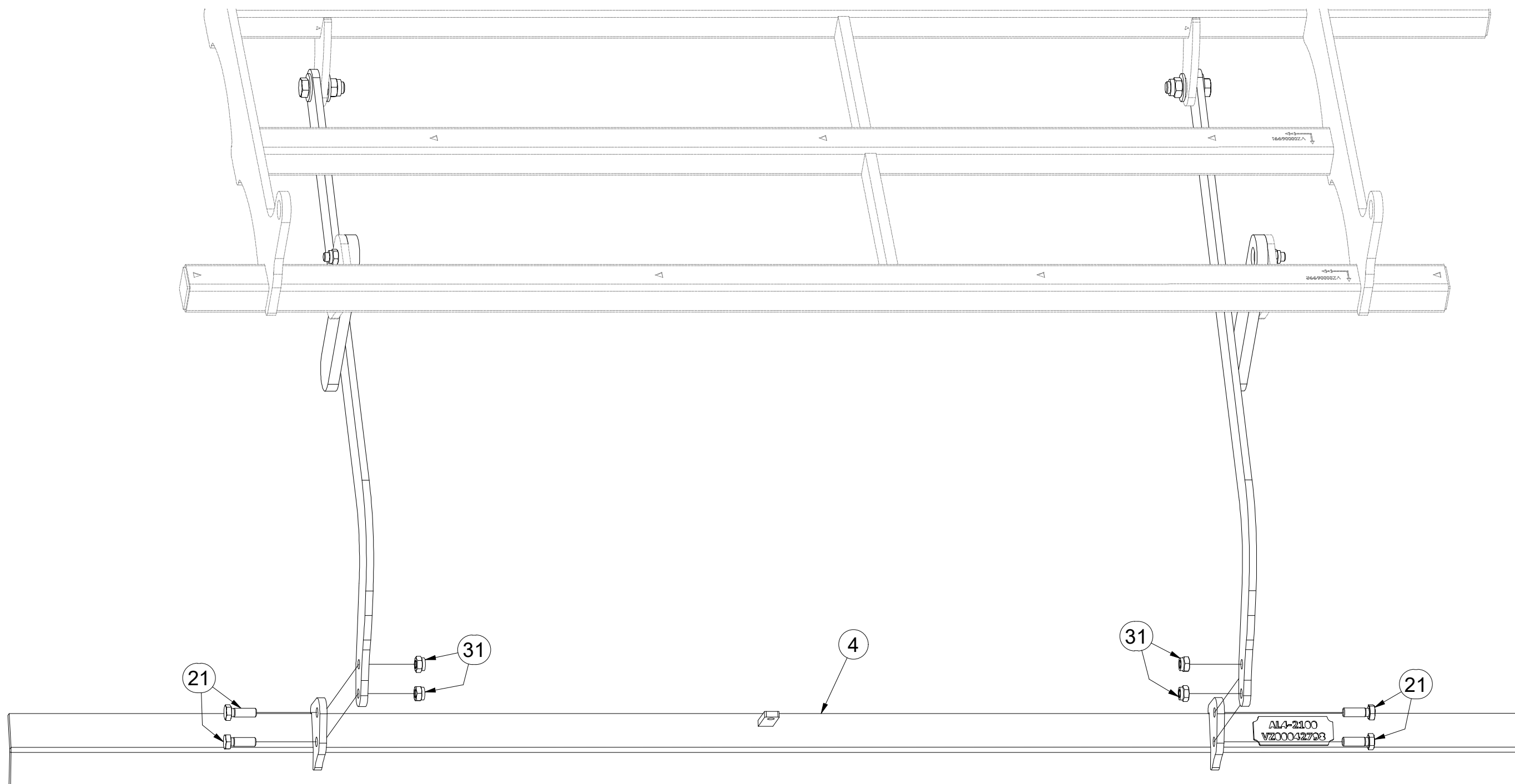
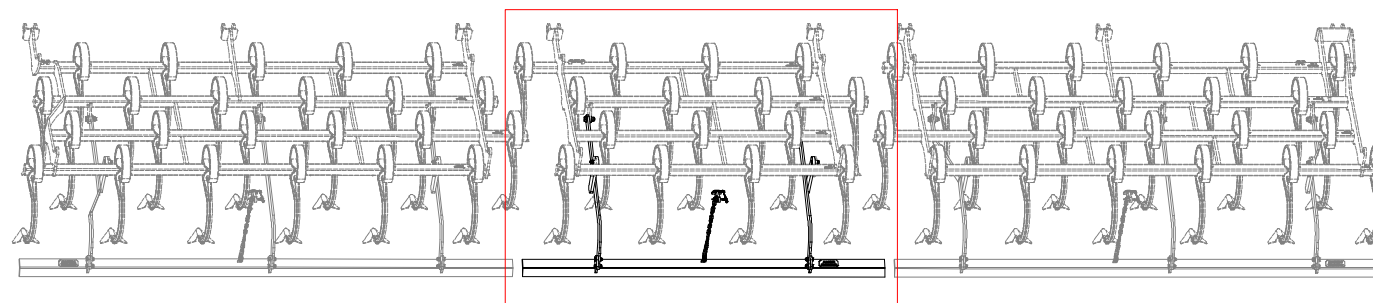

ⒸZ SADA SMYKŮ RADLIC

Ⓓ SATZ SCHARSCHLEPPEN

Ⓕ KIT DE NIVELEURS DES SOCS

ⒸGB SET OF PLOUGHSHARE LEVELLING BARS

ⒸRU КОМПЛЕКТ БОРОН ЛАП

ⒸPL ZESTAW WŁÓK REDLIC



**VZ00043060**

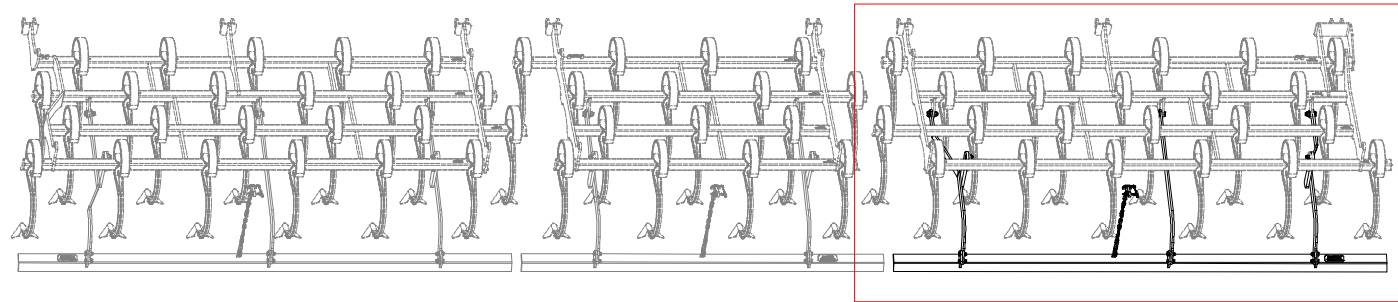

Pos.	Part Number	Pcs.
6	VZ00042812	1
21	m04343	16
31	m04301	28

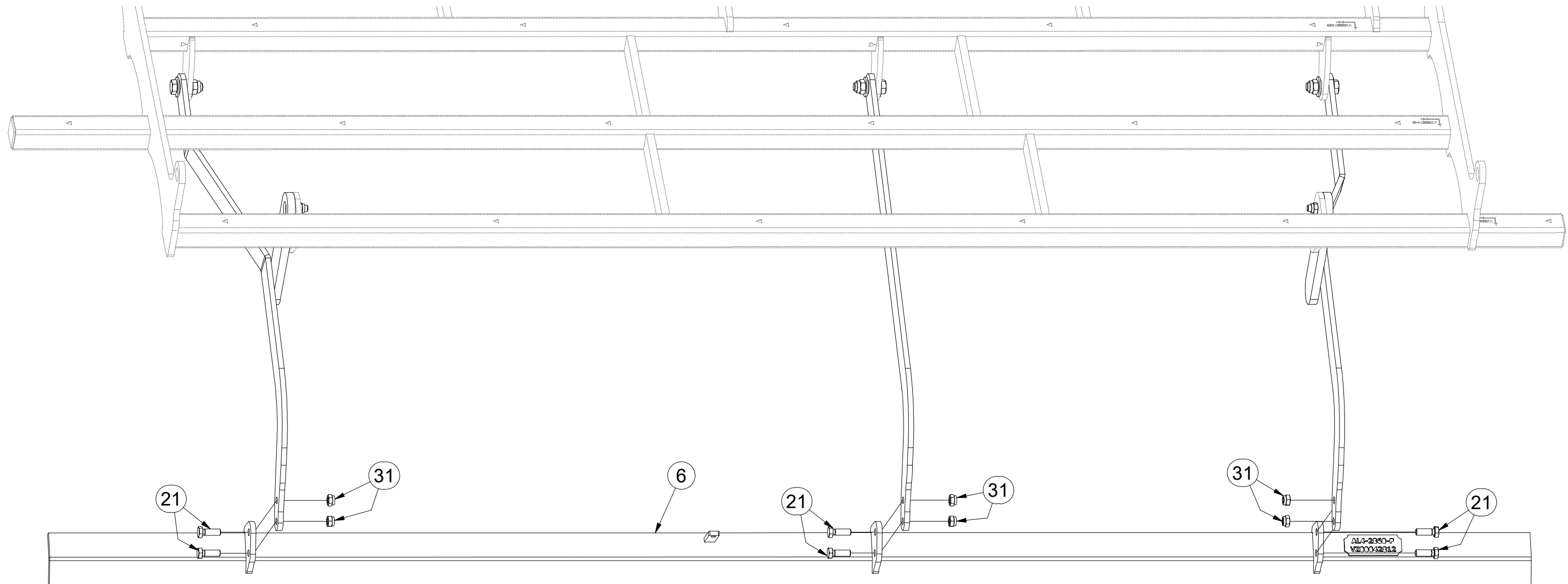

- Ⓒ SADA SMYKŮ RADLIC
- Ⓓ SATZ SCHARSCHLEPPEN
- Ⓕ KIT DE NIVELEURS DES SOCS

- Ⓖ SET OF PLOUGHSHARE LEVELLING BARS
- Ⓡ КОМПЛЕКТ БОРОН ЛАП
- Ⓟ ZESTAW WŁÓK REDLIC



**VZ00043060**

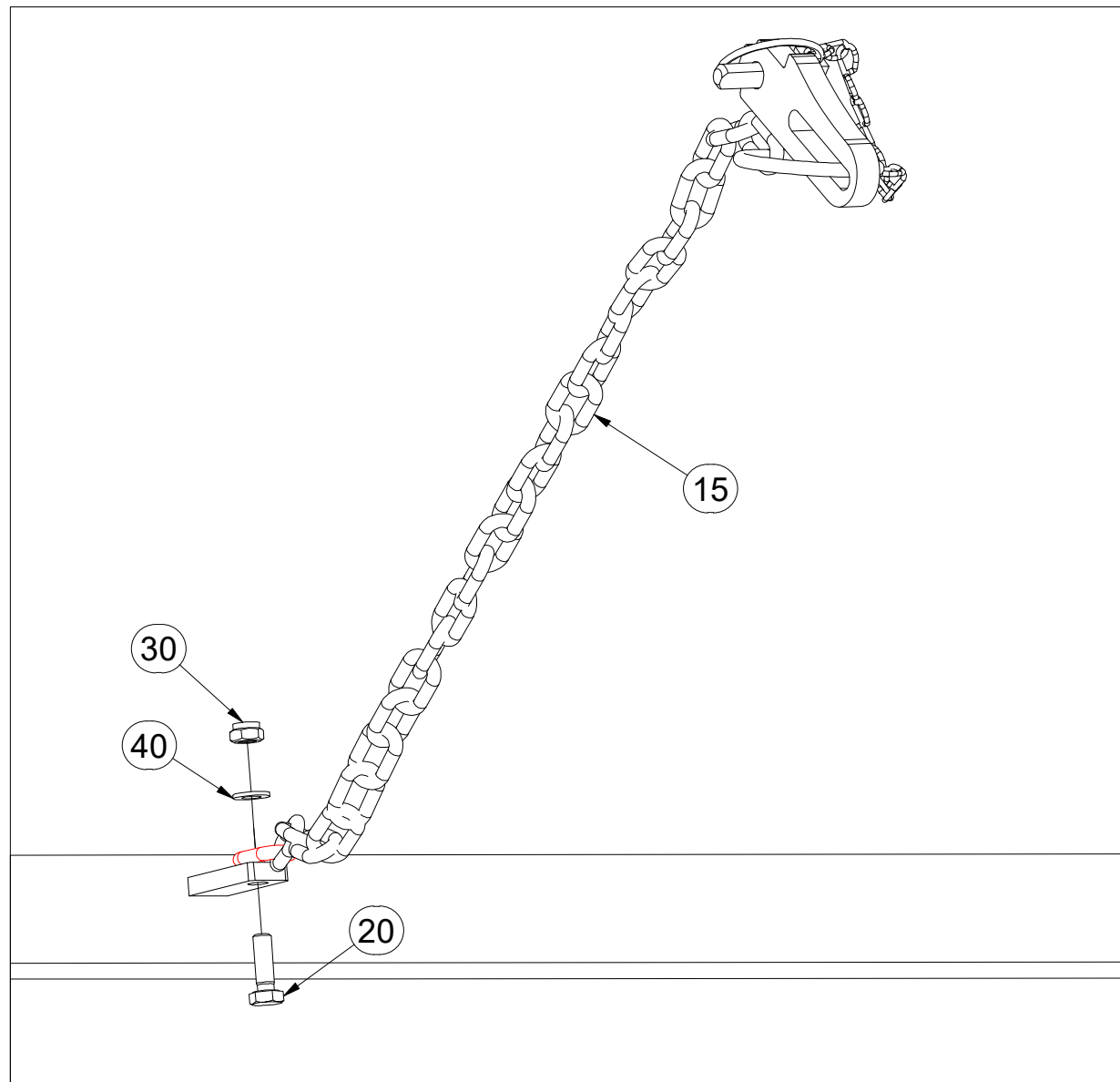
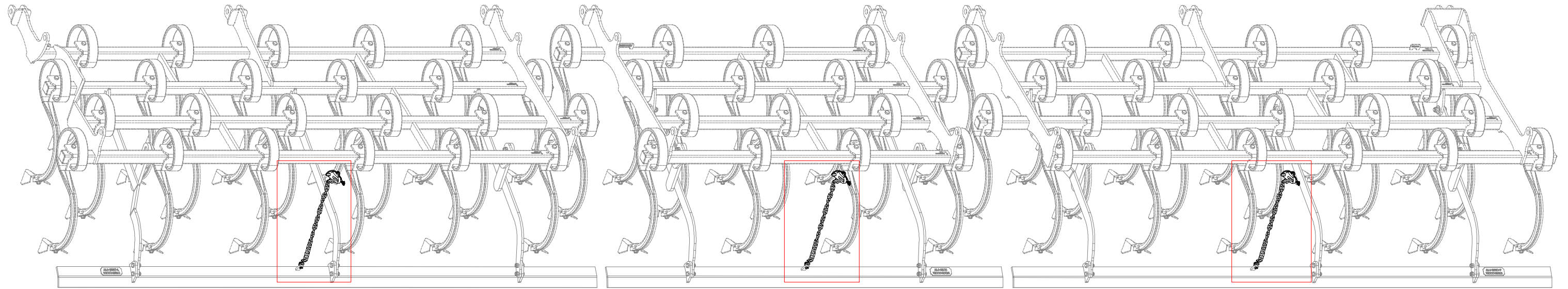

Pos.	Part Number	Pcs.
15	4001641	3
20	m01092	3
30	m04503	3
40	m01203	3

- Ⓒ SADA ZADNÍCH VÁLCŮ
- Ⓓ SATZ HINTERE WALZEN
- Ⓕ KIT DE ROULEAUX ARRIÈRE

- Ⓖ SET OF REAR ROLLERS
- Ⓡ КОМПЛЕКТ ЗАДНИХ КАТКОВ
- Ⓟ ZESTAW TYLNYCH WAŁÓW



**VZ00042789**

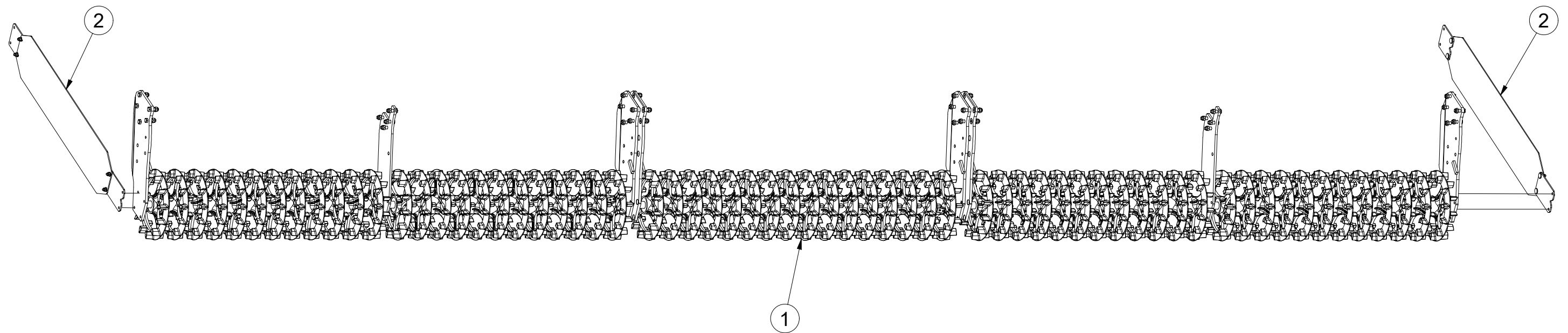

Pos.	Part Number	Pcs.
1	VZ00042791	1
2	VZ00019393	2



ⒸZ SADA ZADNÍCH VÁLCŮ

Ⓓ SATZ HINTERE WALZEN

Ⓕ KIT DE ROULEAUX ARRIÈRE

**VZ00042791**

ⒼB SET OF REAR ROLLERS

ⓇU КОМПЛЕКТ ЗАДНИХ КАТКОВ

ⓅL ZESTAW TYLNYCH WAŁÓW

**Farmet**

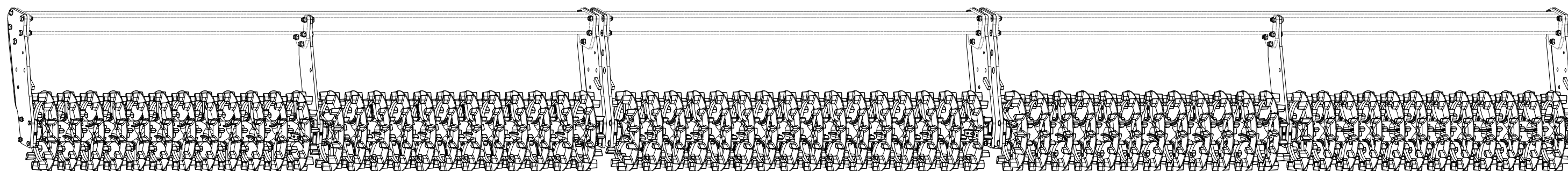

CZ SADA ZADNÍCH VÁLCŮ  
 D SATZ HINTERE WALZEN  
 F KIT DE ROULEAUX ARRIÈRE

GB SET OF REAR ROLLERS  
 RU КОМПЛЕКТ ЗАДНИХ КАТКОВ  
 PL ZESTAW TYLNYCH WAŁÓW



**VZ00042791**

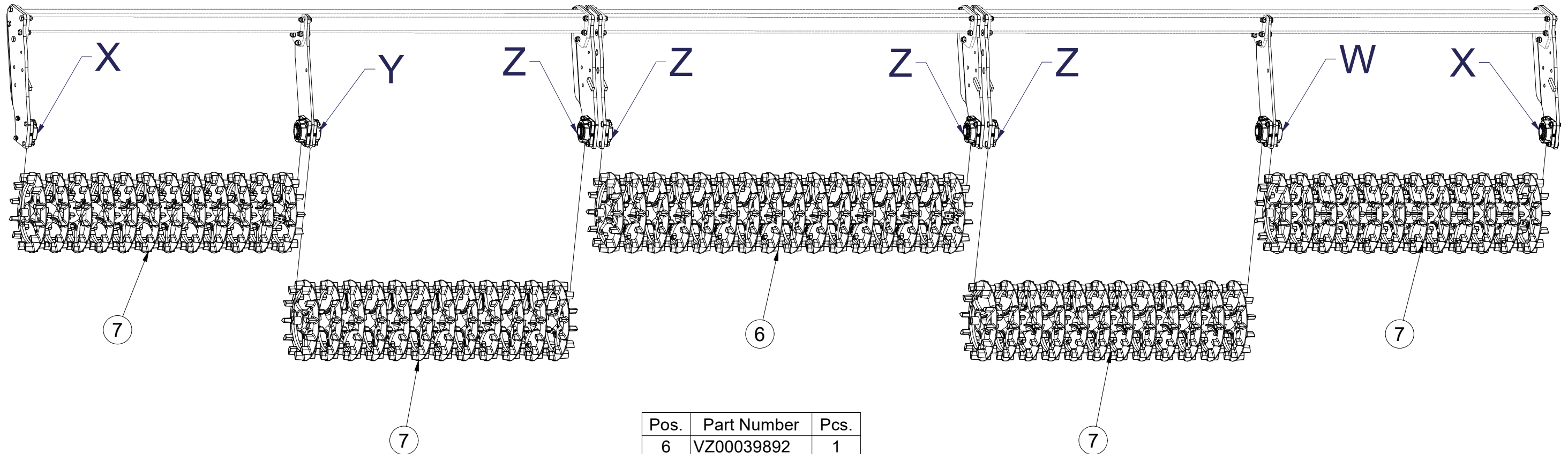

Pos.	Part Number	Pcs.
6	VZ00039892	1
7	VZ00039893	4
10	VZ00038060	4
11	VZ00040131	2
12	VZ00039820	2
13	VZ00039821	2

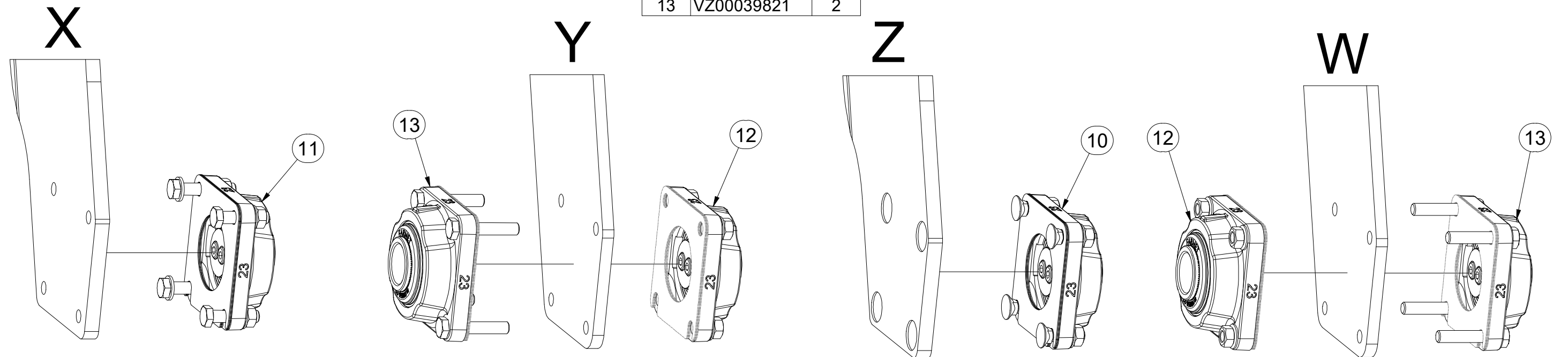

- Ⓒ SADA ZADNÍCH VÁLČŮ
- Ⓓ SATZ HINTERE WALZEN
- Ⓕ KIT DE ROULEAUX ARRIÈRE

- Ⓖ SET OF REAR ROLLERS
- Ⓡ КОМПЛЕКТ ЗАДНИХ КАТКОВ
- Ⓟ ZESTAW TYLNYCH WAŁÓW



**VZ00042791**

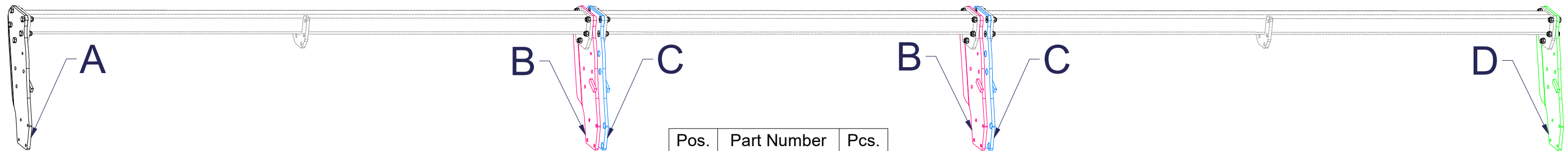

Pos.	Part Number	Pcs.
1	VZ00003134	2
2	VZ00003135	2
4	VZ00006678	1
5	VZ00006680	1
20	m14672	20
21	m10849	18
25	m20385	38

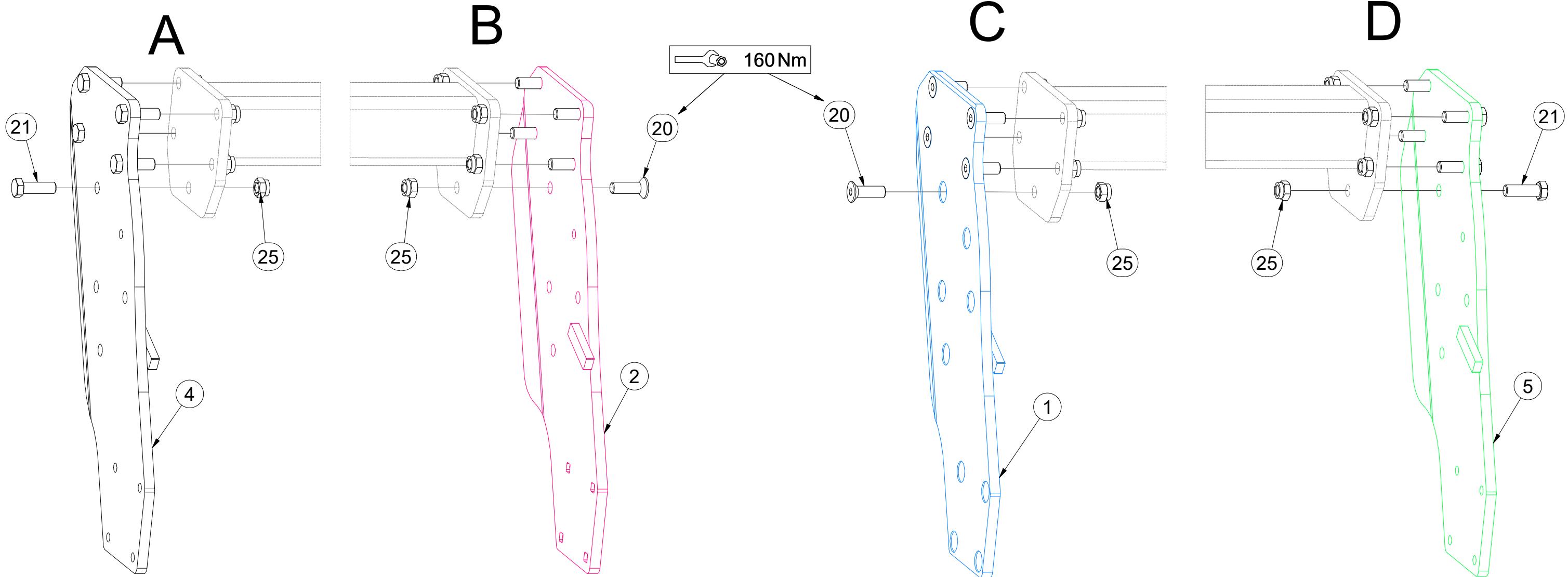

- ⒸZ SADA ZADNÍCH VÁLCŮ
- Ⓓ SATZ HINTERE WALZEN
- Ⓕ KIT DE ROULEAUX ARRIÈRE

- ⒼB SET OF REAR ROLLERS
- ⒹU КОМПЛЕКТ ЗАДНИХ КАТКОВ
- ⒹL ZESTAW TYLNYCH WAŁÓW



**VZ00042791**

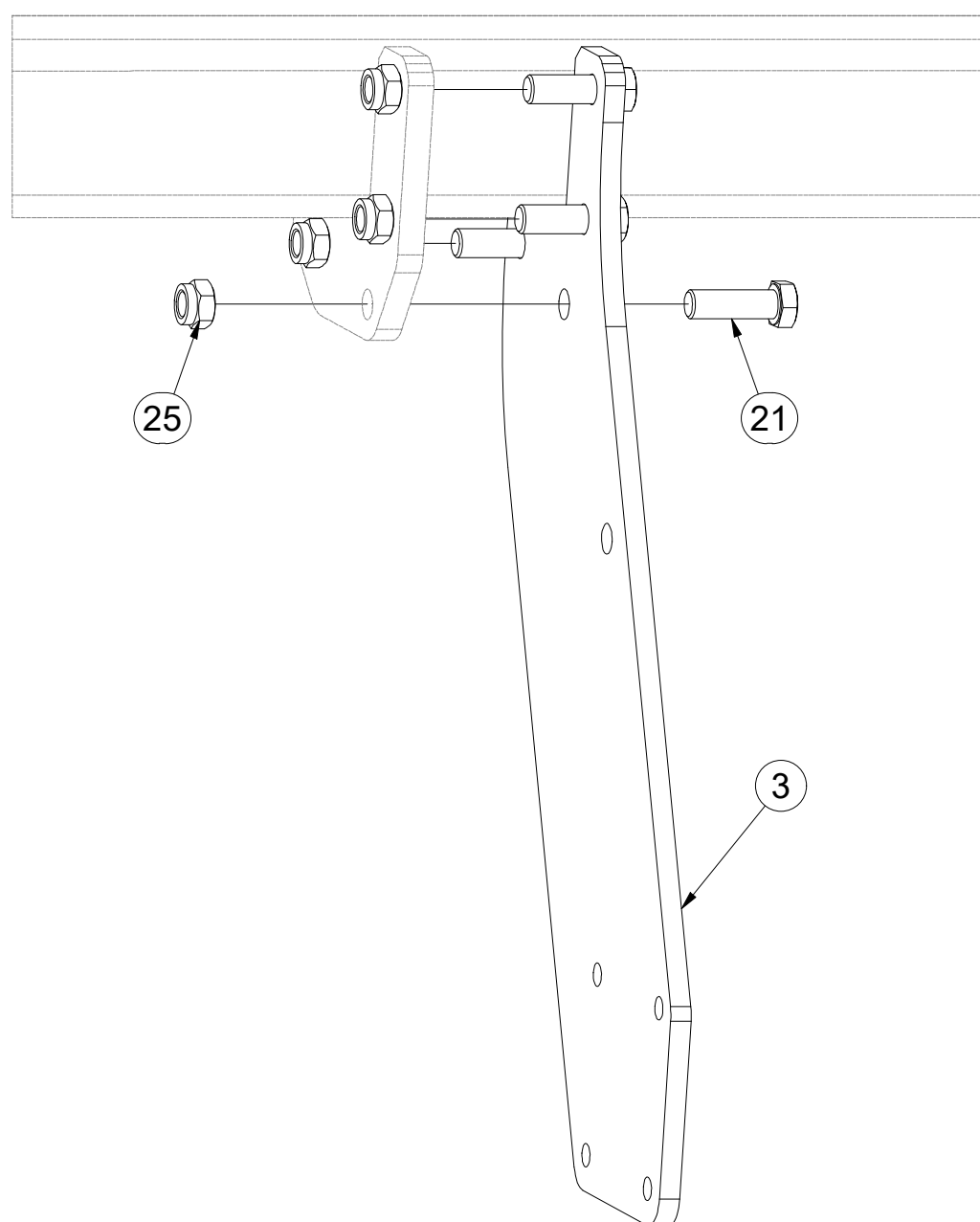

Pos.	Part Number	Pcs.
3	VZ00003151	2
21	m10849	18
25	m20385	38

(CZ) BOČNICE  
 (D) BORDWAND  
 (F) PAROI

(GB) SIDEBORD  
 (RU) БОКОВИНА  
 (PL) PANELE BOCZNE



**VZ00019393**

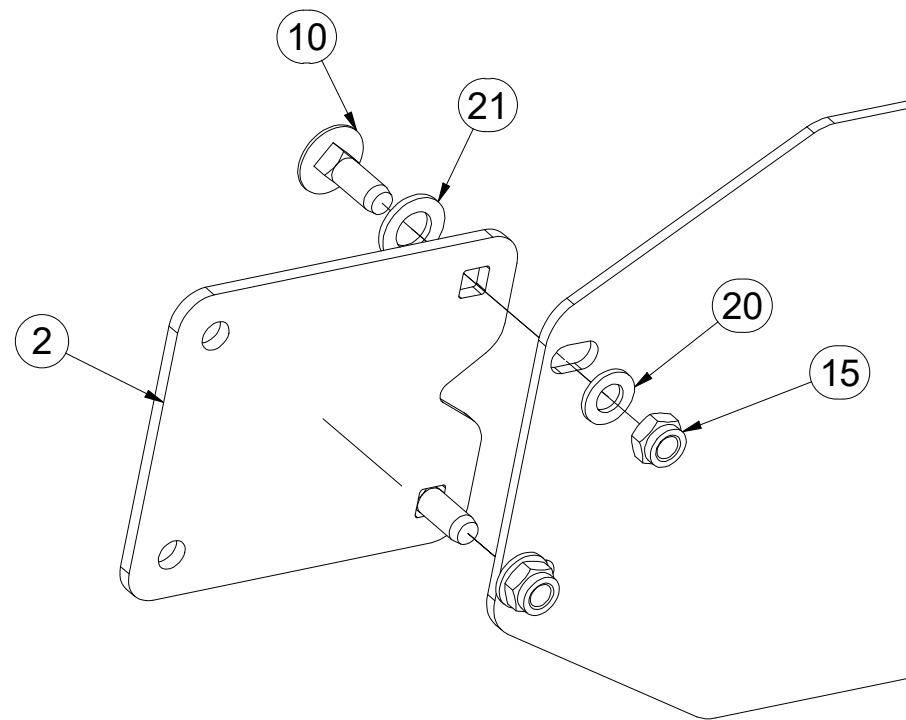
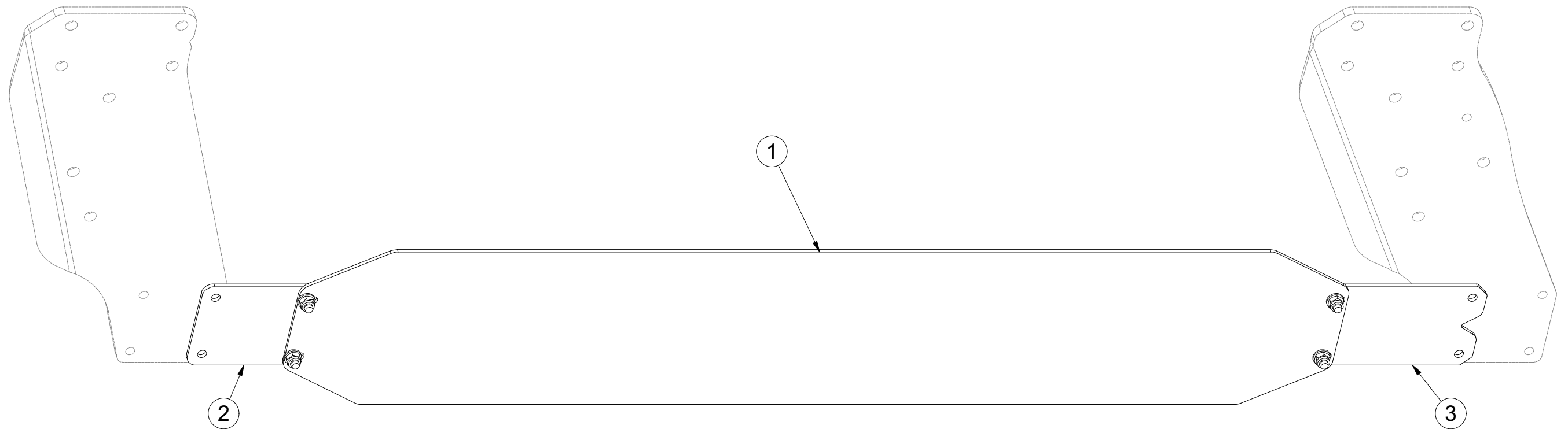

Pos.	Part Number	Pcs.
1	4005373	1
2	VZ00018256	1
3	VZ00018259	1
10	m10618	4
15	m04301	4
20	m17741	4
21	m01219	4

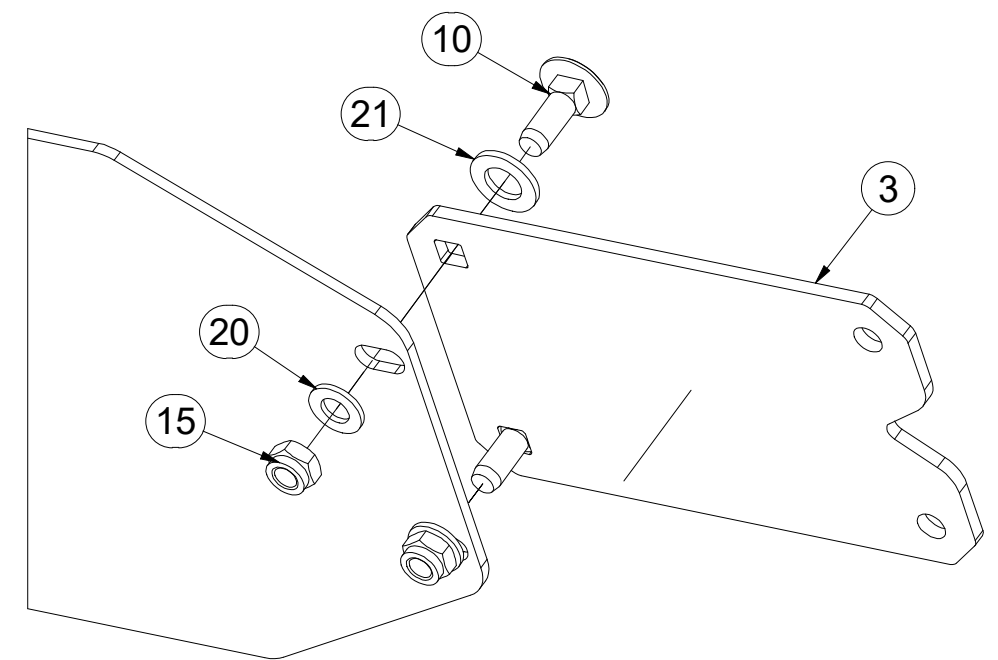

Ⓒ SADA ZADNÍCH VÁLCŮ

Ⓓ SATZ HINTERE WALZEN

Ⓕ KIT DE ROULEAUX ARRIÈRE

**VZ00039892**

Ⓖ SET OF REAR ROLLERS

Ⓡ КОМПЛЕКТ ЗАДНИХ КАТКОВ

Ⓟ ZESTAW TYLNYCH WAŁÓW

**Farmet**

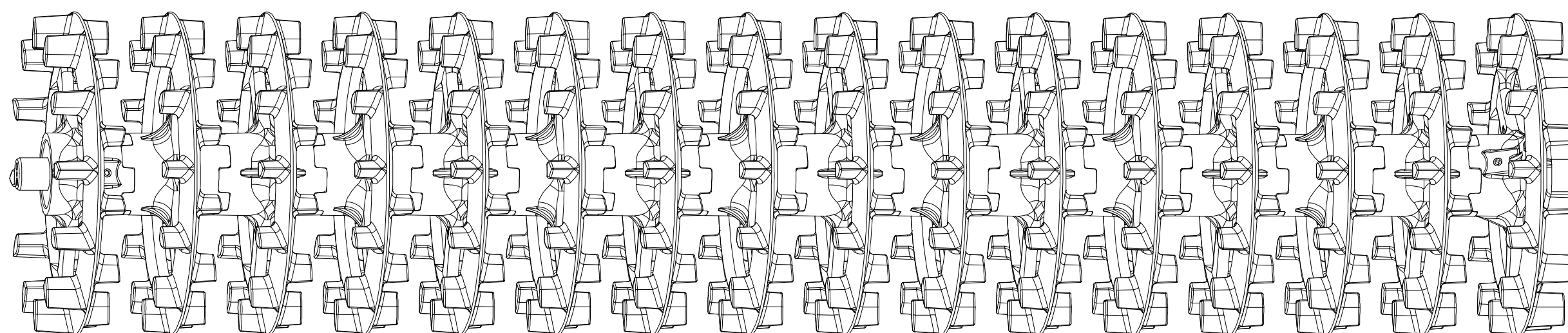
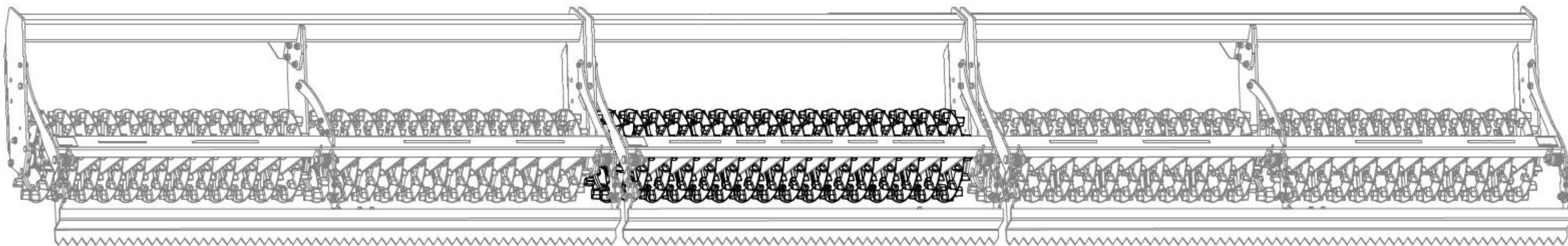

CZ SADA ZADNÍCH VÁLČŮ  
 D SATZ HINTERE WALZEN  
 F KIT DE ROULEAUX ARRIÈRE

GB SET OF REAR ROLLERS  
 RU КОМПЛЕКТ ЗАДНИХ КАТКОВ  
 PL ZESTAW TYLNYCH WAŁÓW



**VZ00039892**

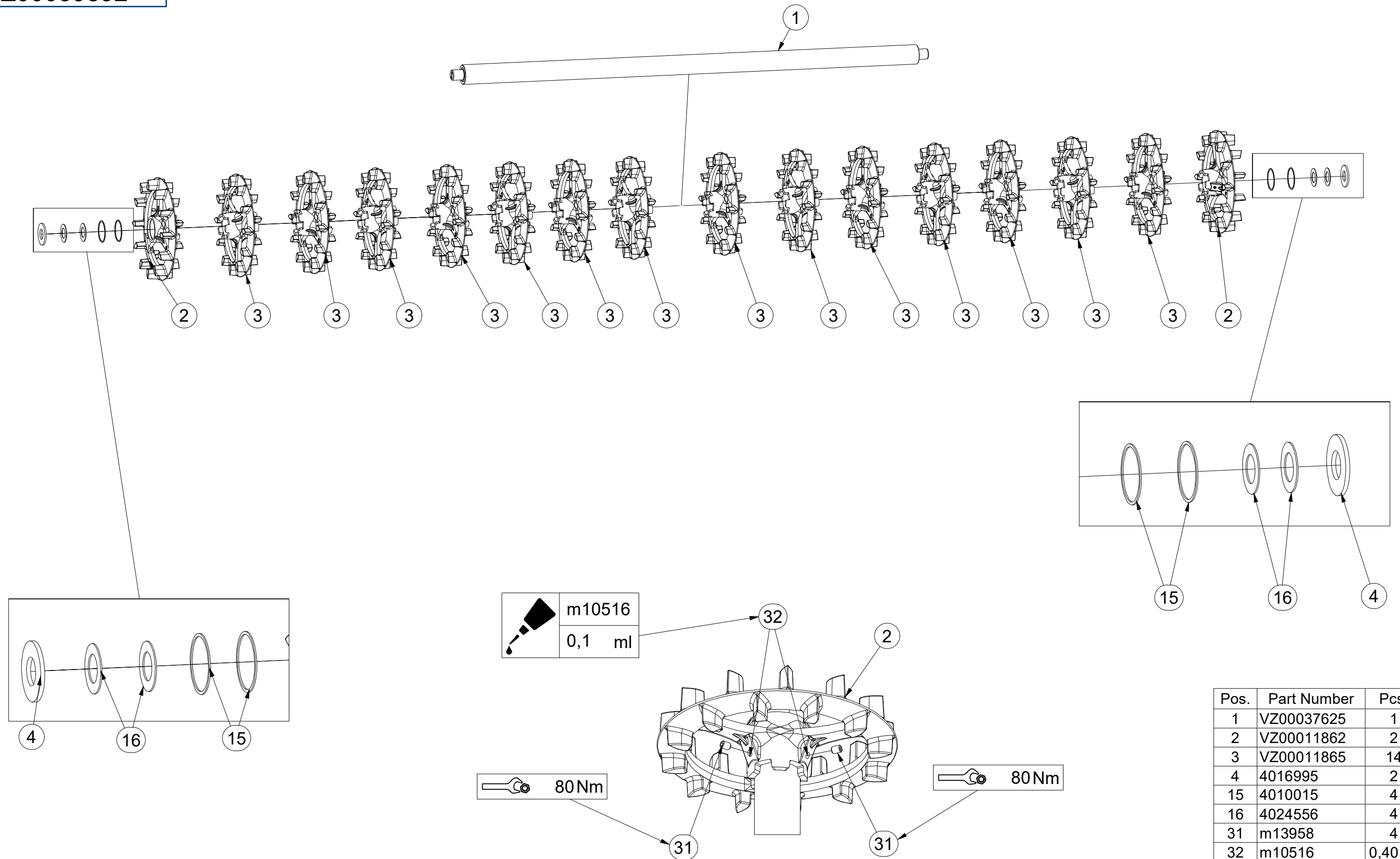

Pos.	Part Number	Pcs.
1	VZ00037625	1
2	VZ00011862	2
3	VZ00011865	14
4	4016995	2
15	4010015	4
16	4024556	4
31	m13958	4
32	m10516	0,40 ml

- Ⓒ SADA ZADNÍCH VÁLCŮ
- Ⓓ SATZ HINTERE WALZEN
- Ⓕ KIT DE ROULEAUX ARRIÈRE

**VZ00039893**

- Ⓖ SET OF REAR ROLLERS
- Ⓡ КОМПЛЕКТ ЗАДНИХ КАТКОВ
- Ⓟ ZESTAW TYLNYCH WAŁÓW

**Farmet**

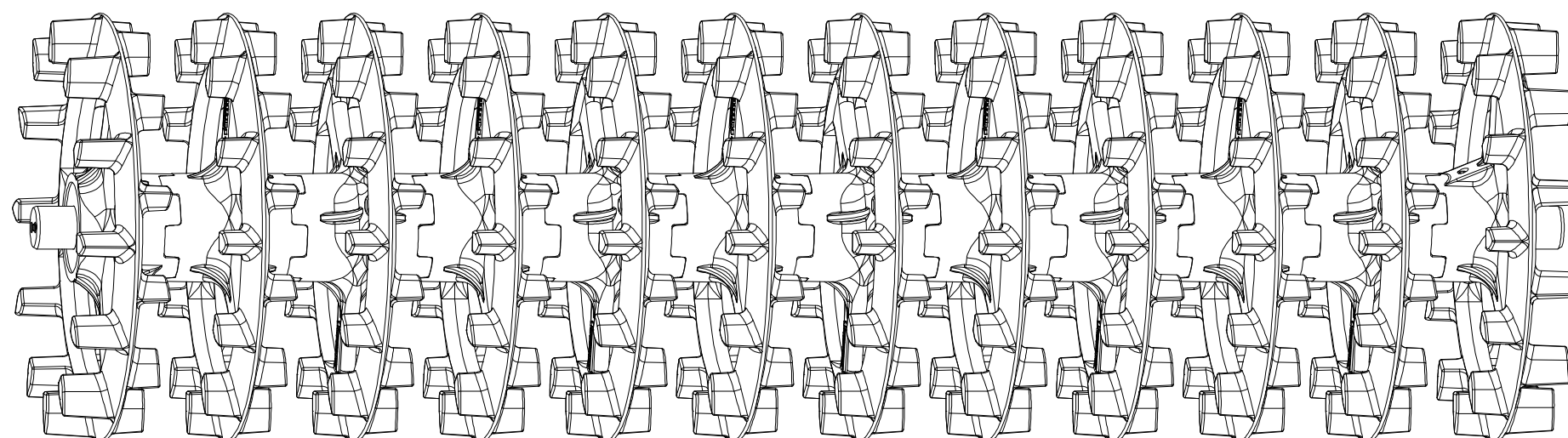
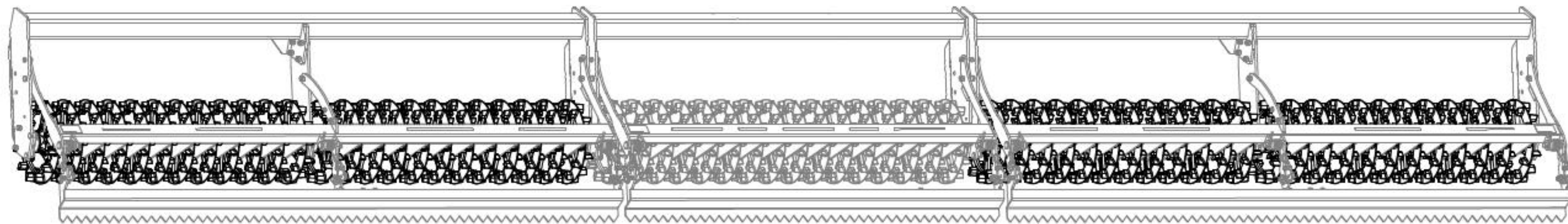



CZ SADA ZADNÍCH VÁLCŮ  
 D SATZ HINTERE WALZEN  
 F KIT DE ROULEAUX ARRIÈRE

GB SET OF REAR ROLLERS  
 RU КОМПЛЕКТ ЗАДНИХ КАТКОВ  
 PL ZESTAW TYLNYCH WAŁÓW



**VZ00039893**

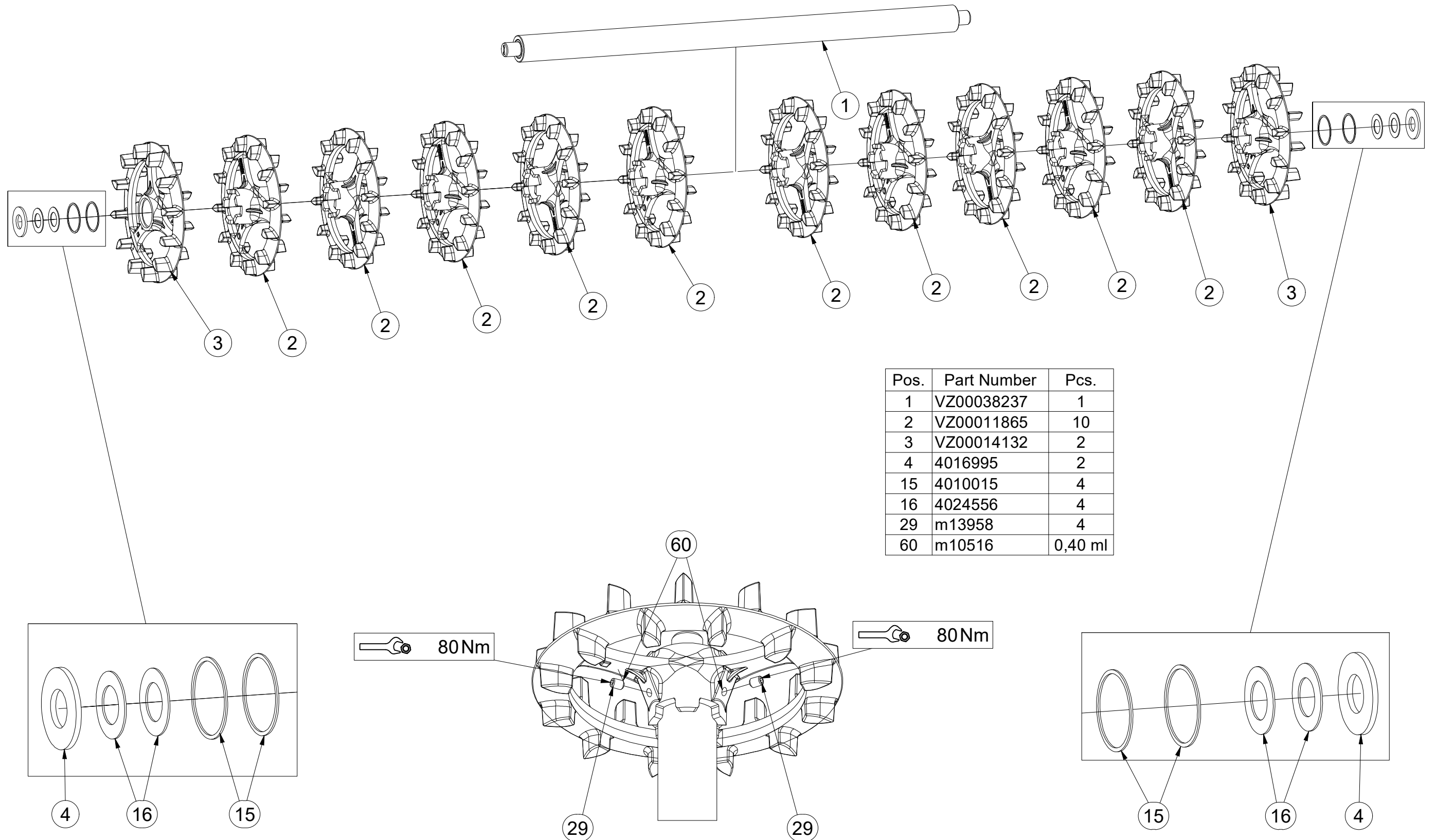

ⒸZ SMYKY ZADNÍCH VÁLCŮ

Ⓓ SCHLEIFE HINTERE WALZE

Ⓕ NIVELEUR ARRIÈRE ROULEAUX

**VZ00041675**

ⒸGB REAR ROLLERS LEVELLERS

ⒸRU БОРОНЫ ЗАДНИХ КАТКОВ

ⒸPL WŁÓKY TYLNYCH WAŁÓW

**Farmet**

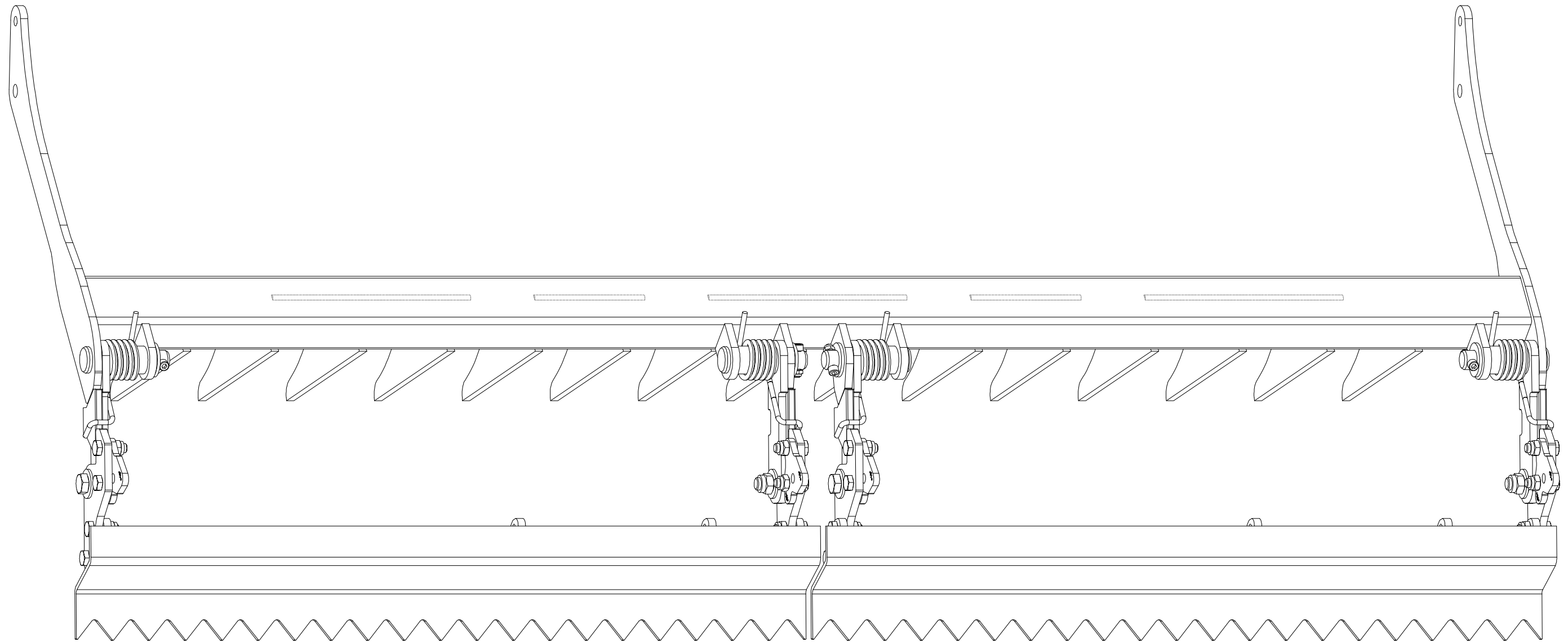



CZ SMYKY ZADNÍCH VÁLCŮ  
 D SCHLEIFE HINTERE WALZE  
 F NIVELEUR ARRIÈRE ROULEAUX

GB REAR ROLLERS LEVELLERS  
 RU БОРОНЫ ЗАДНИХ КАТКОВ  
 PL WŁÓKY TYLNYCH WAŁOW



**VZ00041675**

Pos.	Part Number	Pcs.
10	VZ00038536	4
21	m04343	8
31	m04301	8

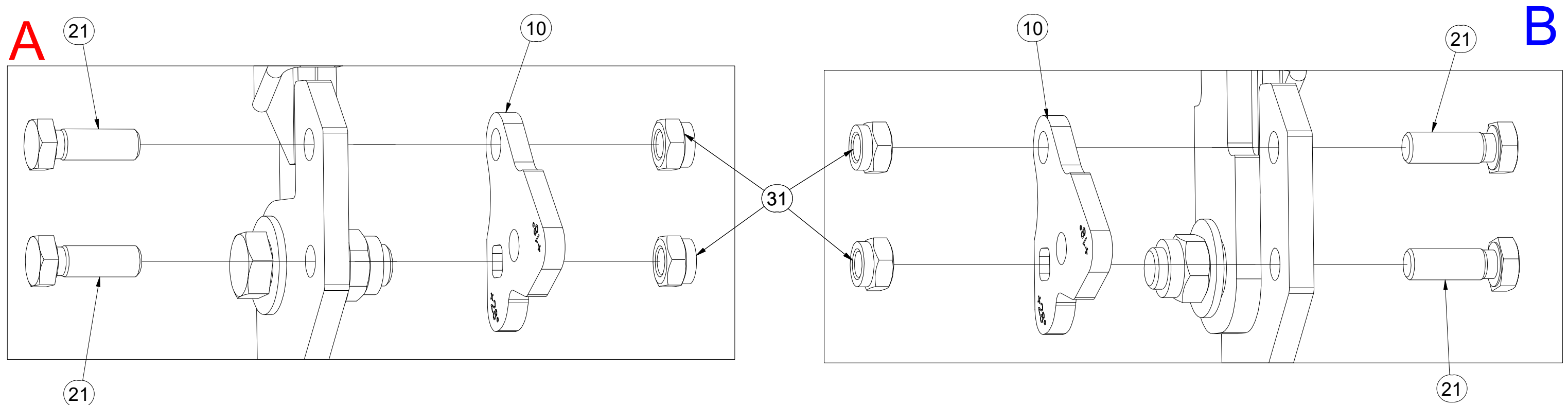
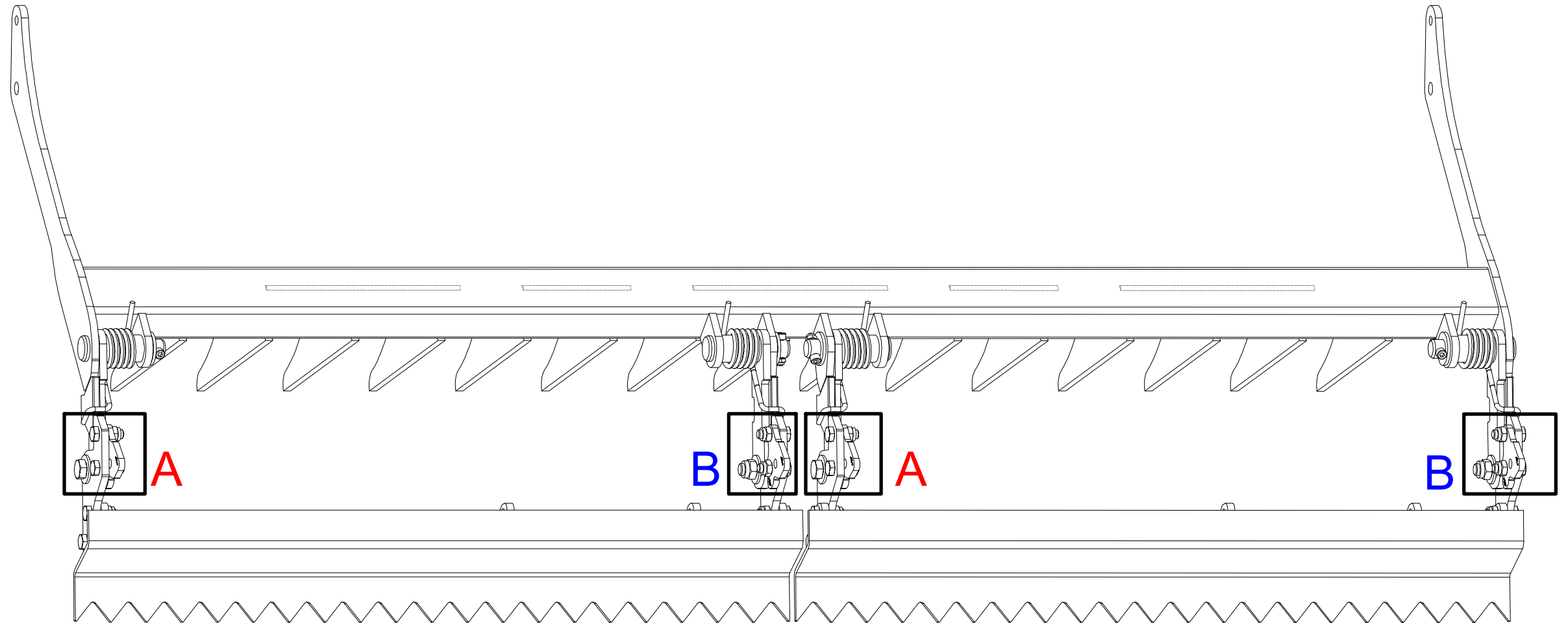

ⒸZ SMYKY ZADNÍCH VÁLCŮ

Ⓓ SCHLEIFE HINTERE WALZE

Ⓕ NIVELEUR ARRIÈRE ROULEAUX

**VZ00041881**

ⒼB REAR ROLLERS LEVELLERS

ⒺB БОРОНЫ ЗАДНИХ КАТКОВ

ⒽL WŁÓKY TYLNYCH WAŁOW

**Farmet**

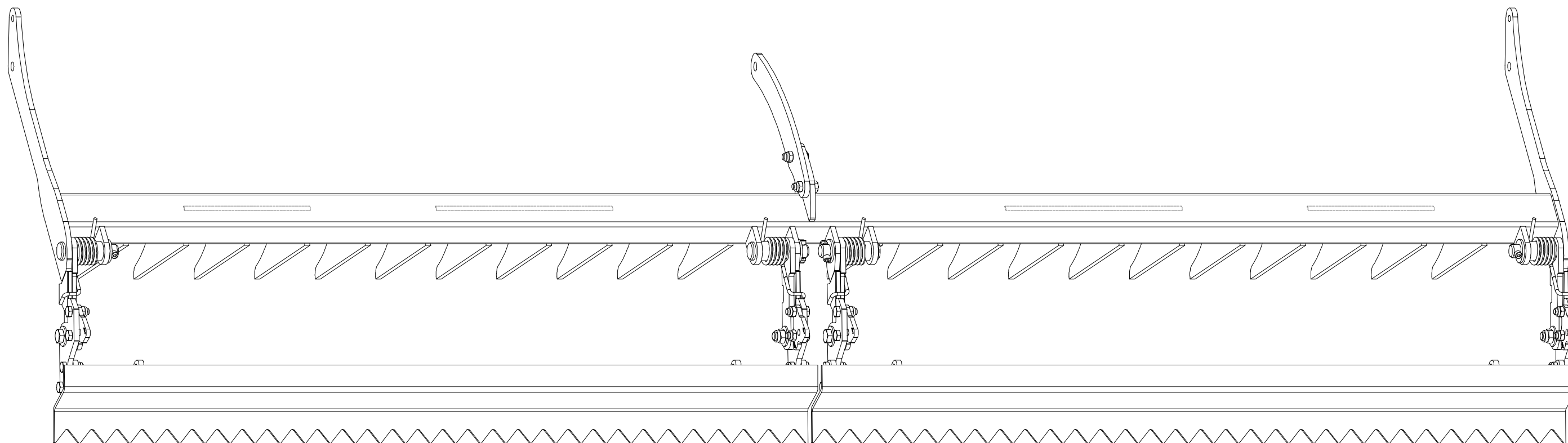

CZ SMYKY ZADNÍCH VÁLCŮ  
 D SCHLEIFE HINTERE WALZE  
 F NIVELEUR ARRIÈRE ROULEAUX

GB REAR ROLLERS LEVELLERS  
 RU БОРОНЫ ЗАДНИХ КАТКОВ  
 PL WŁÓKY TYLNYCH WAŁOW



**VZ00041881**

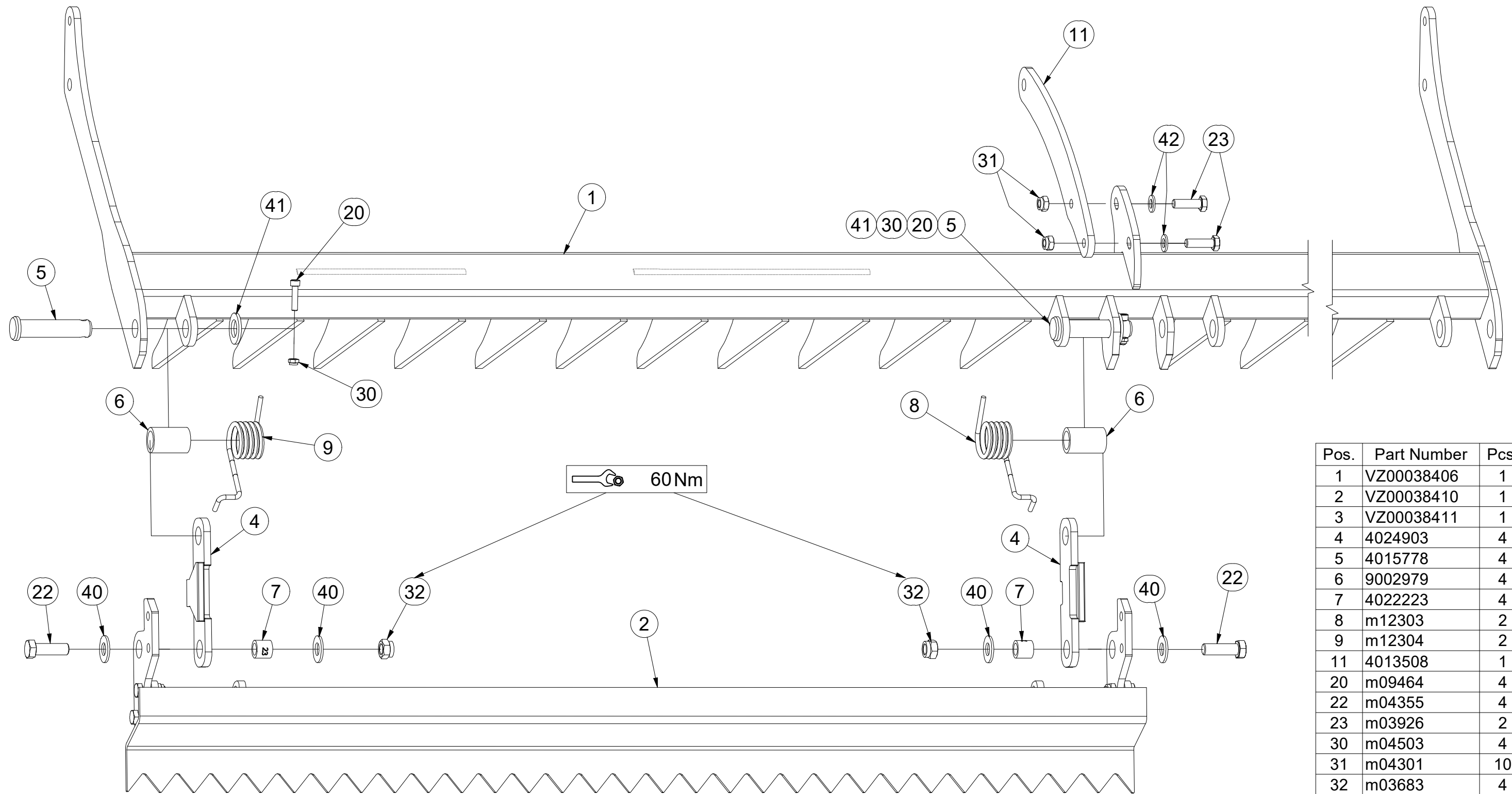

Pos.	Part Number	Pcs.
1	VZ00038406	1
2	VZ00038410	1
3	VZ00038411	1
4	4024903	4
5	4015778	4
6	9002979	4
7	4022223	4
8	m12303	2
9	m12304	2
11	4013508	1
20	m09464	4
22	m04355	4
23	m03926	2
30	m04503	4
31	m04301	10
32	m03683	4
40	m05651	8
41	m14028	4
42	m17741	2

Ⓒ SMYKY ZADNÍCH VÁLCŮ

Ⓓ SCHLEIFE HINTERE WALZE

Ⓕ NIVELEUR ARRIÈRE ROULEAUX

Ⓒ REAR ROLLERS LEVELLERS

Ⓓ БОРОНЫ ЗАДНИХ КАТКОВ

Ⓕ WŁÓKY TYLNYCH WAŁOW



**VZ00041881**

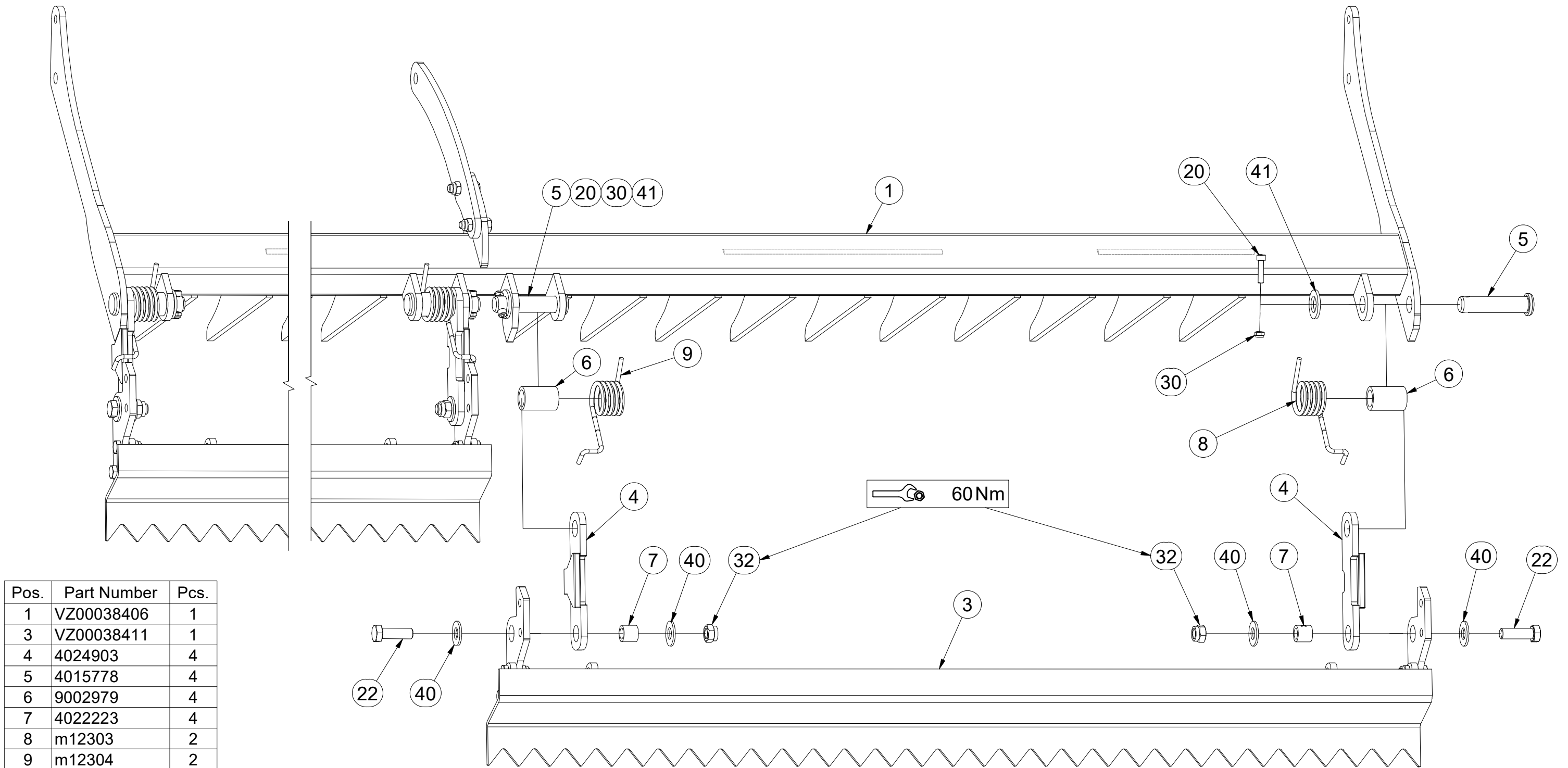

Pos.	Part Number	Pcs.
1	VZ00038406	1
3	VZ00038411	1
4	4024903	4
5	4015778	4
6	9002979	4
7	4022223	4
8	m12303	2
9	m12304	2
20	m09464	4
22	m04355	4
30	m04503	4
32	m03683	4
40	m05651	8
41	m14028	4

CZ SMYKY ZADNÍCH VÁLCŮ  
 D SCHLEIFE HINTERE WALZE  
 F NIVELEUR ARRIÈRE ROULEAUX

GB REAR ROLLERS LEVELLERS  
 RU БОРОНЫ ЗАДНИХ КАТКОВ  
 PL WŁÓKY TYLNYCH WAŁOW



**VZ00041881**

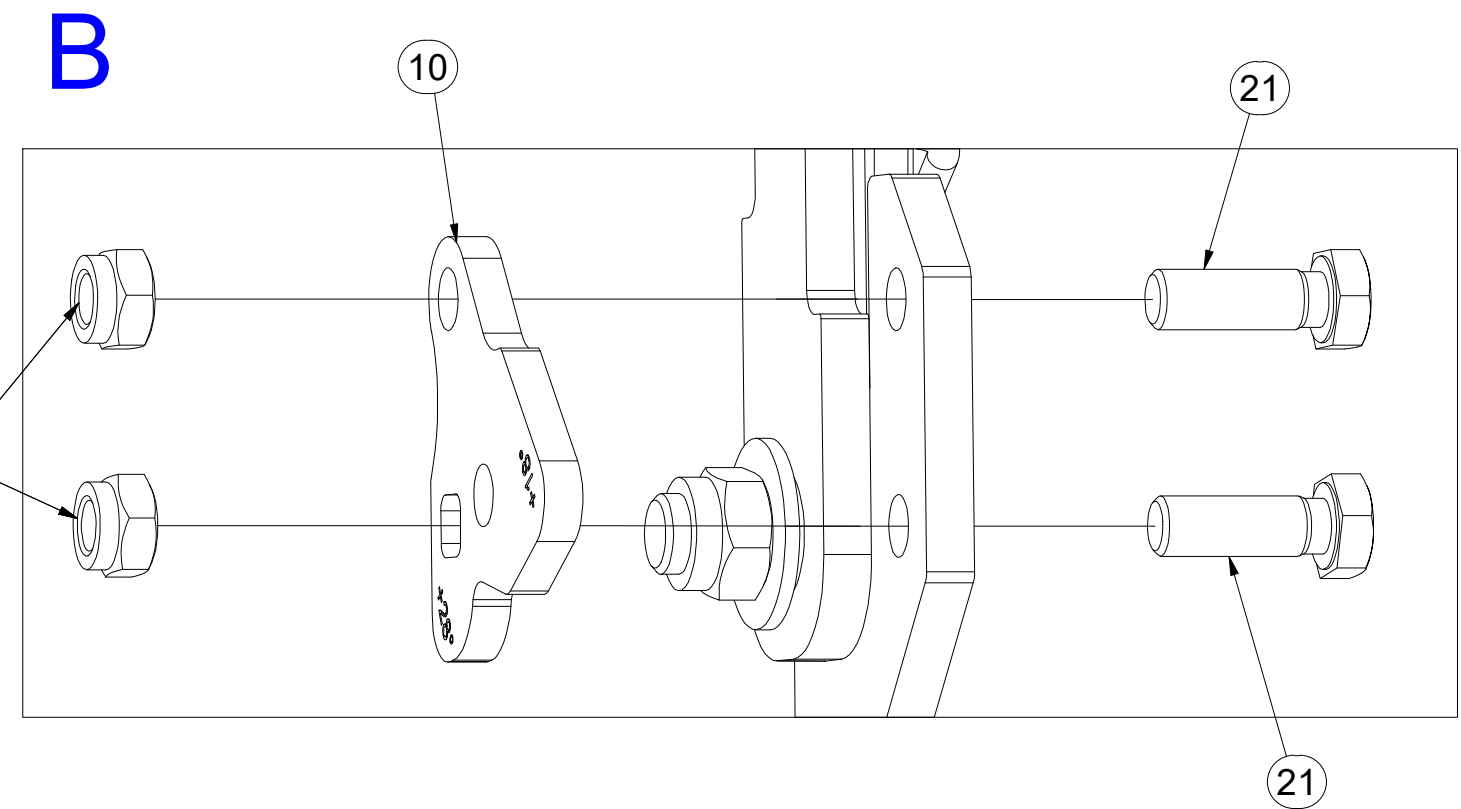
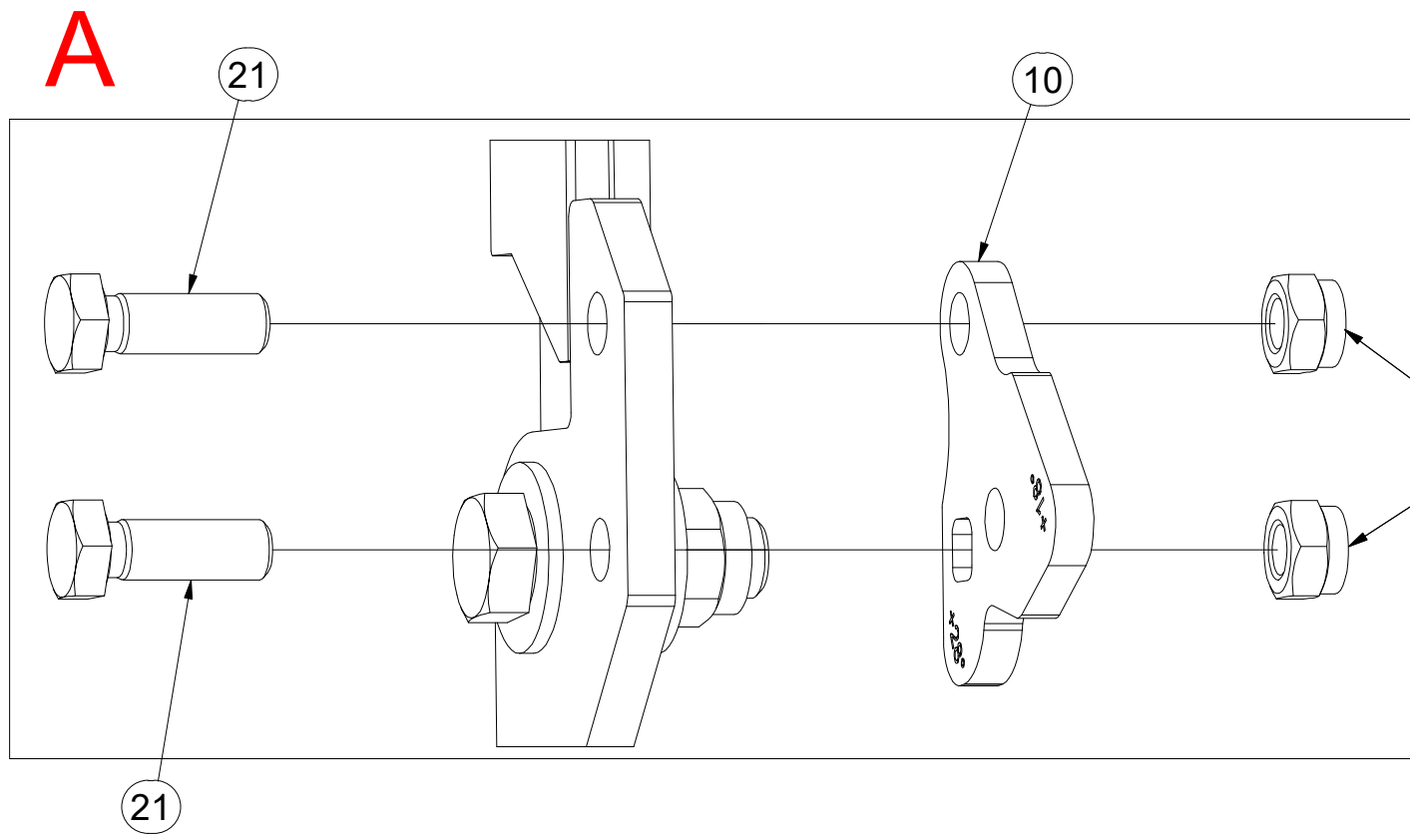
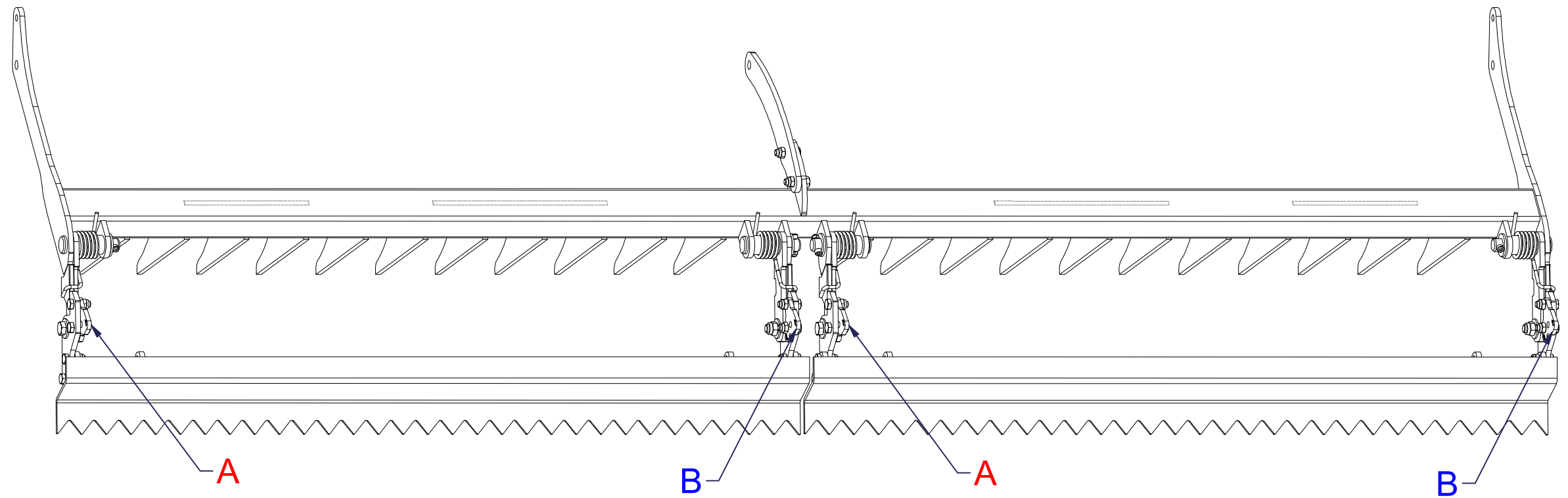

Pos.	Part Number	Pcs.
10	VZ00038536	4
21	m04343	8
31	m04301	10



- Ⓒ SADA ZADNÍCH VÁLČŮ
- Ⓓ SATZ HINTERE WALZEN
- Ⓕ KIT DE ROULEAUX ARRIÈRE

- Ⓖ SET OF REAR ROLLERS
- Ⓡ КОМПЛЕКТ ЗАДНИХ КАТКОВ
- Ⓟ ZESTAW TYLNYCH WAŁÓW



**VZ00042792**

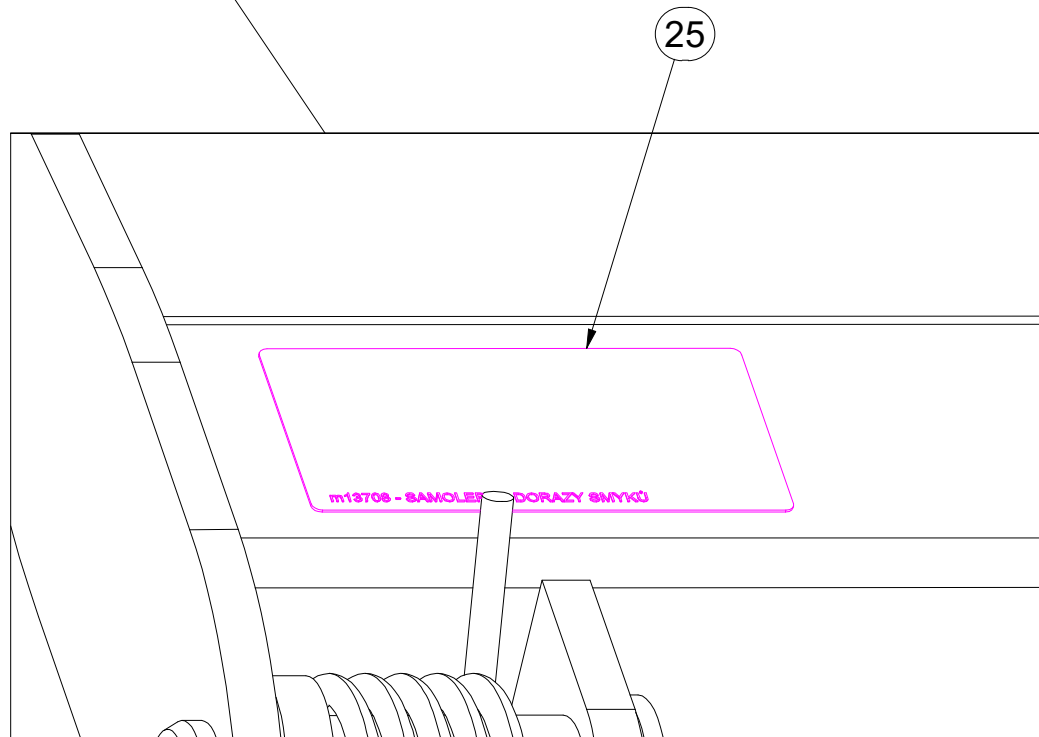
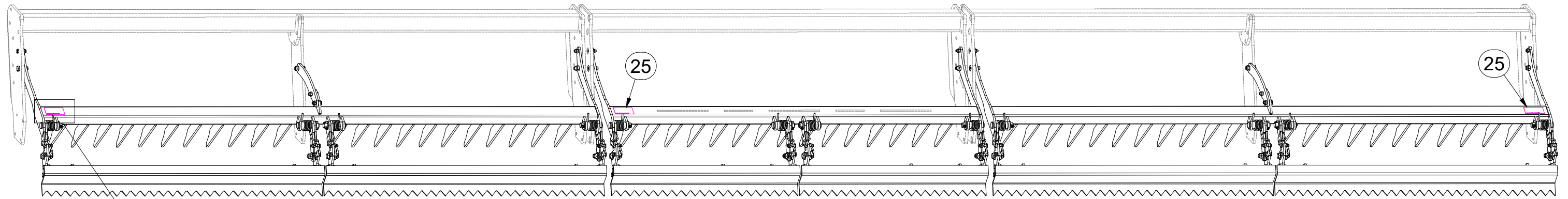

Pos.	Part Number	Pcs.
25	m13708	3

- ⒸZ SADA ZADNÍCH VÁLČŮ
- Ⓓ SATZ HINTERE WALZEN
- Ⓕ KIT DE ROULEAUX ARRIÈRE

- ⒼB SET OF REAR ROLLERS
- ⒺR КОМПЛЕКТ ЗАДНИХ КАТКОВ
- ⒼL ZESTAW TYLNYCH WAŁÓW



**VZ00042792**

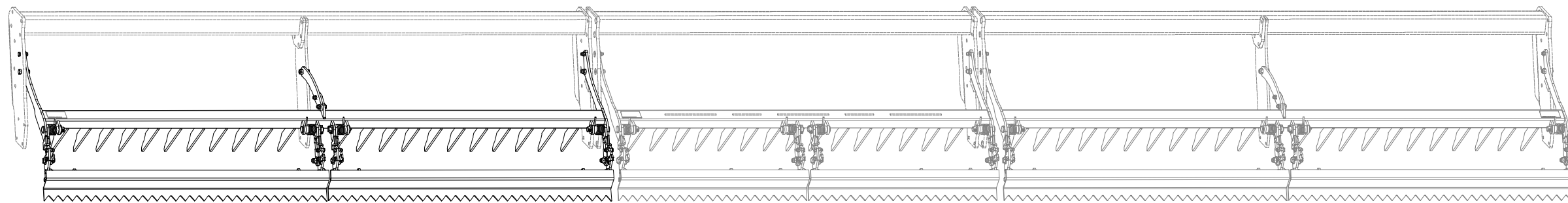

Pos.	Part Number	Pcs.
2	VZ00041881	2
10	m03926	2
11	m01129	2
12	m19996	4
13	m02254	2
14	m14672	4
20	m04301	6
21	m03683	8

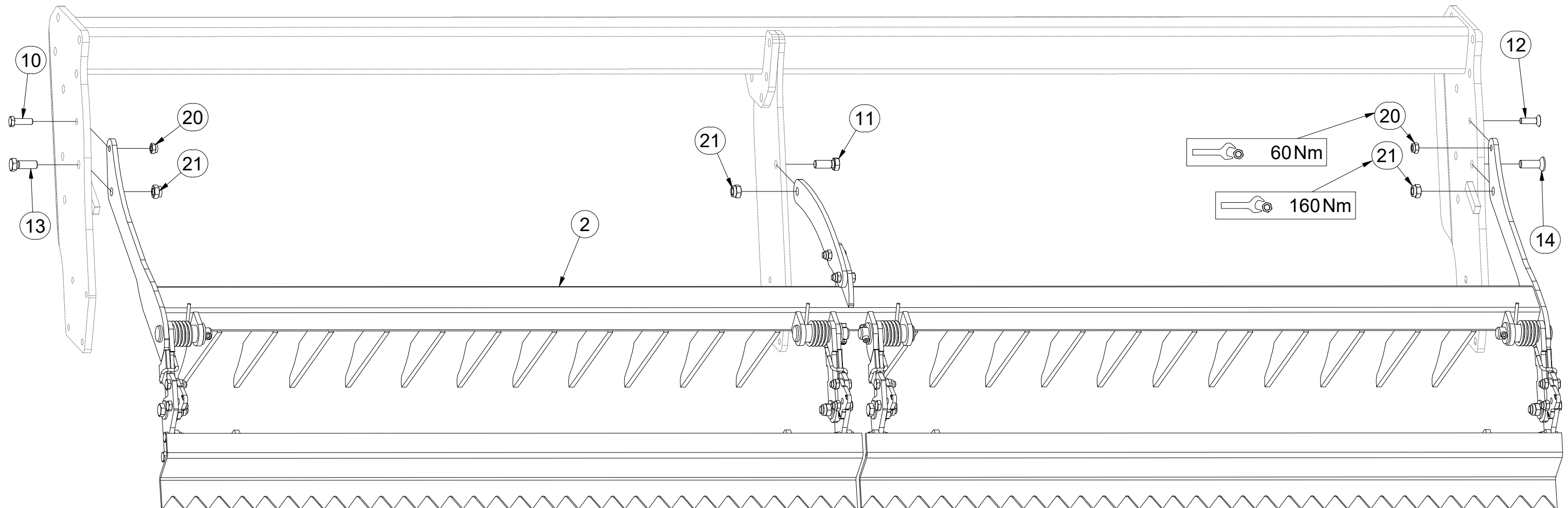

- Ⓒ SADA ZADNÍCH VÁLCŮ
- Ⓓ SATZ HINTERE WALZEN
- Ⓕ KIT DE ROULEAUX ARRIÈRE

- Ⓖ SET OF REAR ROLLERS
- Ⓡ КОМПЛЕКТ ЗАДНИХ КАТКОВ
- Ⓟ ZESTAW TYLNYCH WAŁÓW



**VZ00042792**

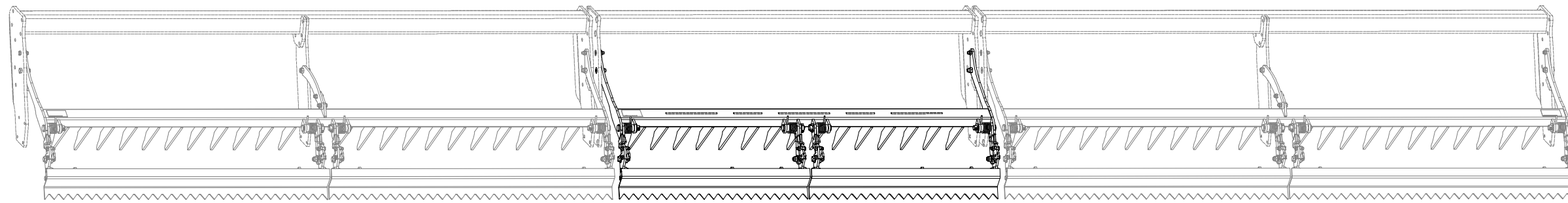

Pos.	Part Number	Pcs.
1	VZ00041675	1
12	m19996	4
14	m14672	4
20	m04301	6
21	m03683	8

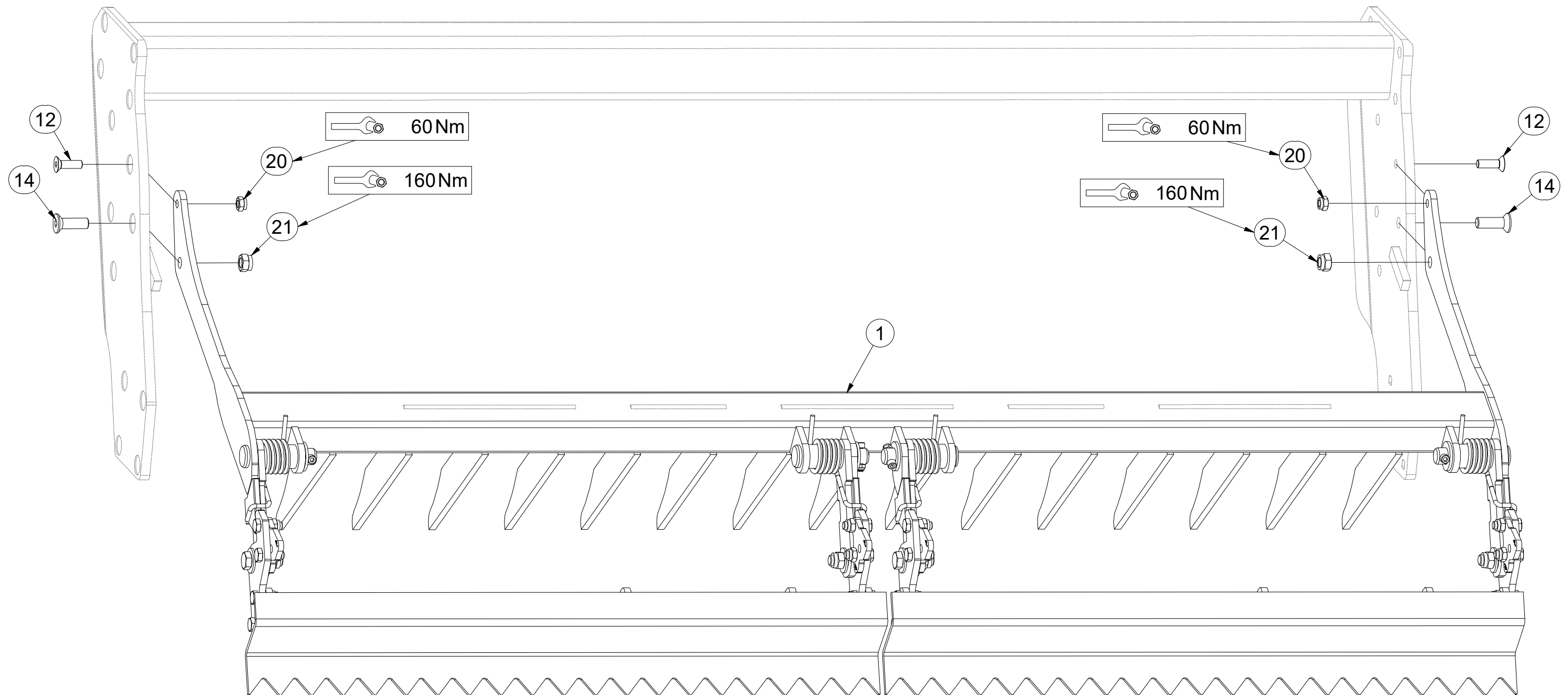

- Ⓒ SADA ZADNÍCH VÁLCŮ
- Ⓓ SATZ HINTERE WALZEN
- Ⓕ KIT DE ROULEAUX ARRIÈRE

- Ⓖ SET OF REAR ROLLERS
- Ⓡ КОМПЛЕКТ ЗАДНИХ КАТКОВ
- Ⓟ ZESTAW TYLNYCH WAŁÓW



**VZ00042792**

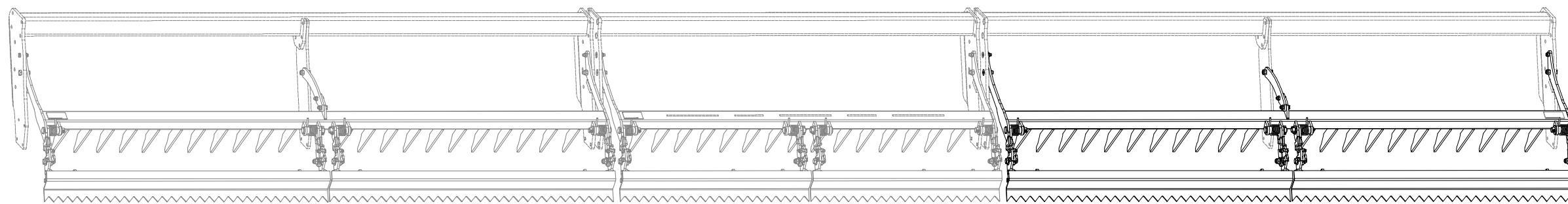

Pos.	Part Number	Pcs.
2	VZ00041881	2
10	m03926	2
11	m01129	2
12	m19996	4
13	m02254	2
14	m14672	4
20	m04301	6
21	m03683	8

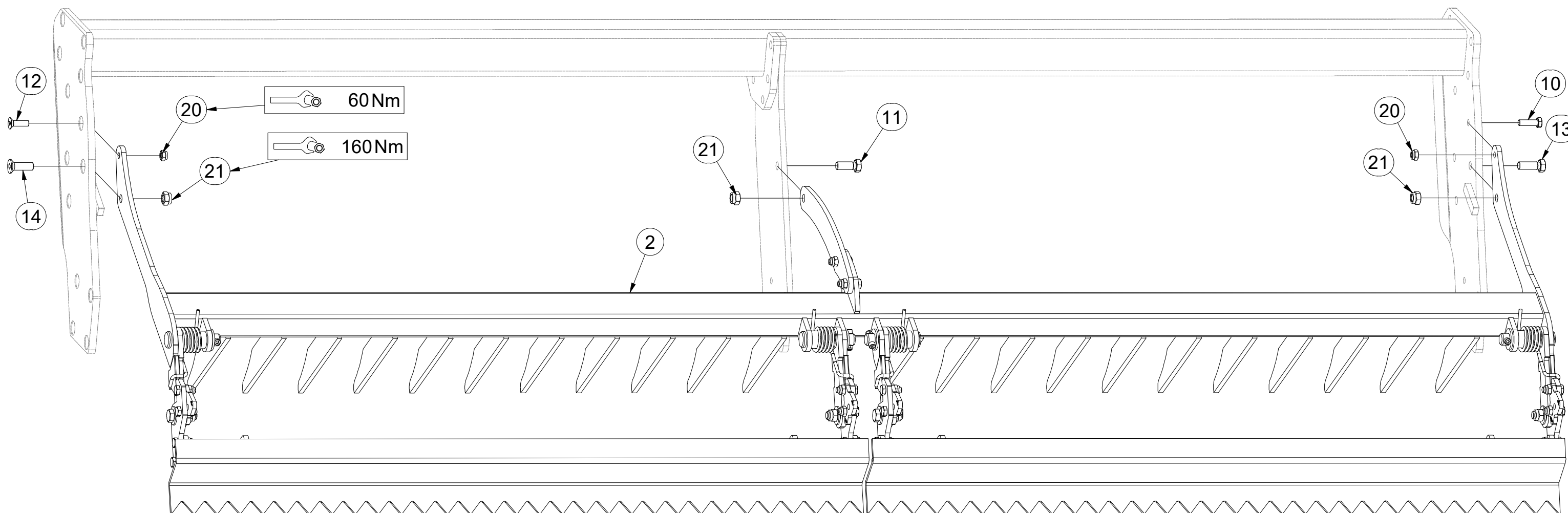

Ⓒ SMYK

Ⓓ ACKERSCHLEIFE

Ⓕ NIVELEUR

Ⓖ LEVELLER

Ⓡ БОРОНА

Ⓟ WŁÓKA



**VZ00034296**

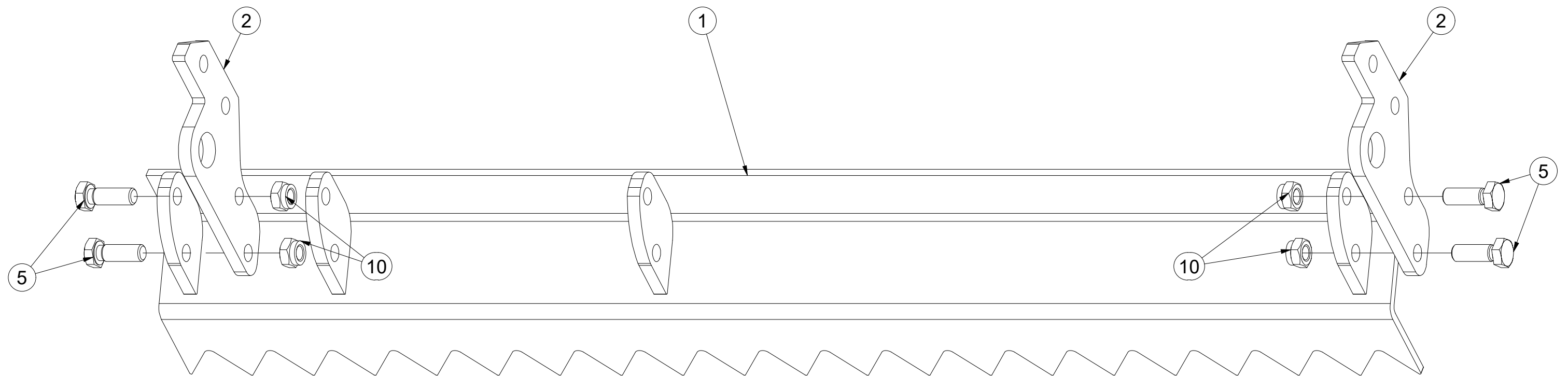

Pos.	Part Number	Pcs.
1	VZ00034293	1
2	VZ00014941	2
5	m04343	4
10	m04301	4

Ⓒ SMYK

Ⓓ ACKERSCHLEIFE

Ⓕ NIVELEUR

Ⓖ LEVELLER

Ⓡ БОРОНА

Ⓟ WŁÓKA



**VZ00034297**

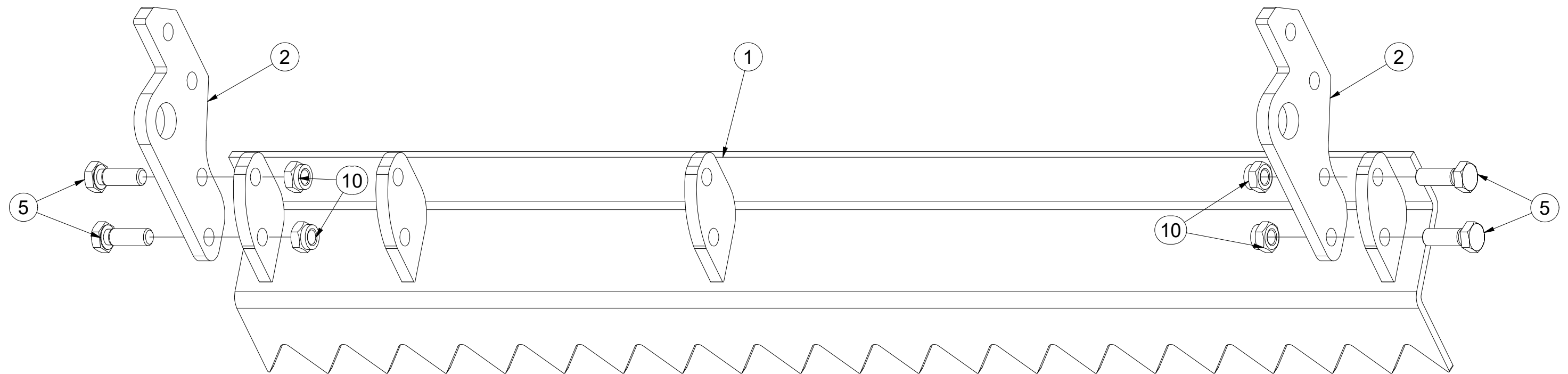

Pos.	Part Number	Pcs.
1	VZ00034293	1
2	VZ00014941	2
5	m04343	4
10	m04301	4

Ⓒ SMYK

Ⓓ ACKERSCHLEIFE

Ⓕ NIVELEUR

**VZ00038410**

Ⓖ LEVELLER

Ⓡ БОРОНА

Ⓟ WŁÓKA

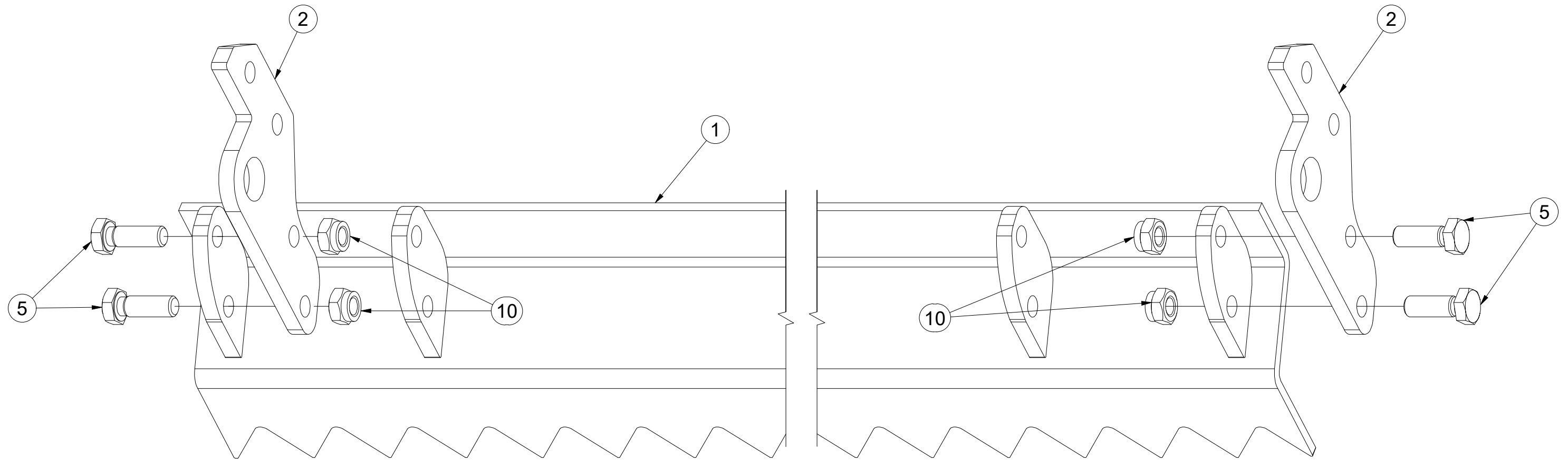

Pos.	Part Number	Pcs.
1	VZ00042095	1
2	VZ00014941	2
5	m04343	4
10	m04301	4

Ⓒ SMYK

Ⓓ ACKERSCHLEIFE

Ⓕ NIVELEUR

**VZ00038411**

Ⓖ LEVELLER

Ⓡ БОРОНА

Ⓟ WŁÓKA

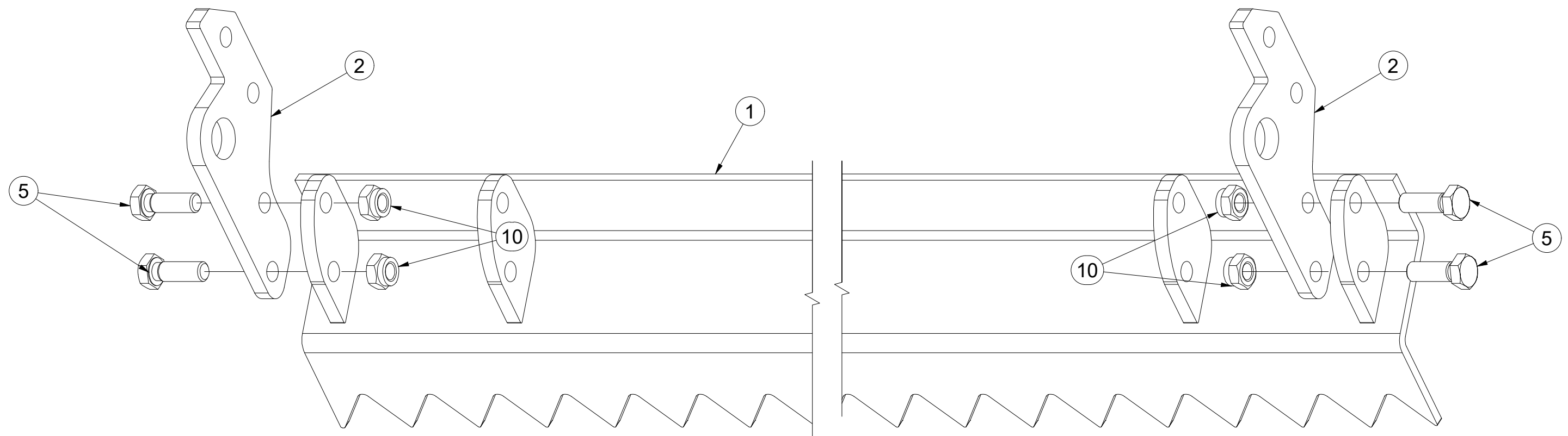

Pos.	Part Number	Pcs.
1	VZ00042095	1
2	VZ00014941	2
5	m04343	4
10	m04301	4



CZ SADA LOŽISEK  
 D SATZ LAGER  
 F KIT DE ROULEMENTS

GB SET OF BEARINGS  
 RU КОМПЛЕКТ ПОДШИПНИКОВ  
 PL ZESTAW ŁOŻYSK



**VZ00038060**

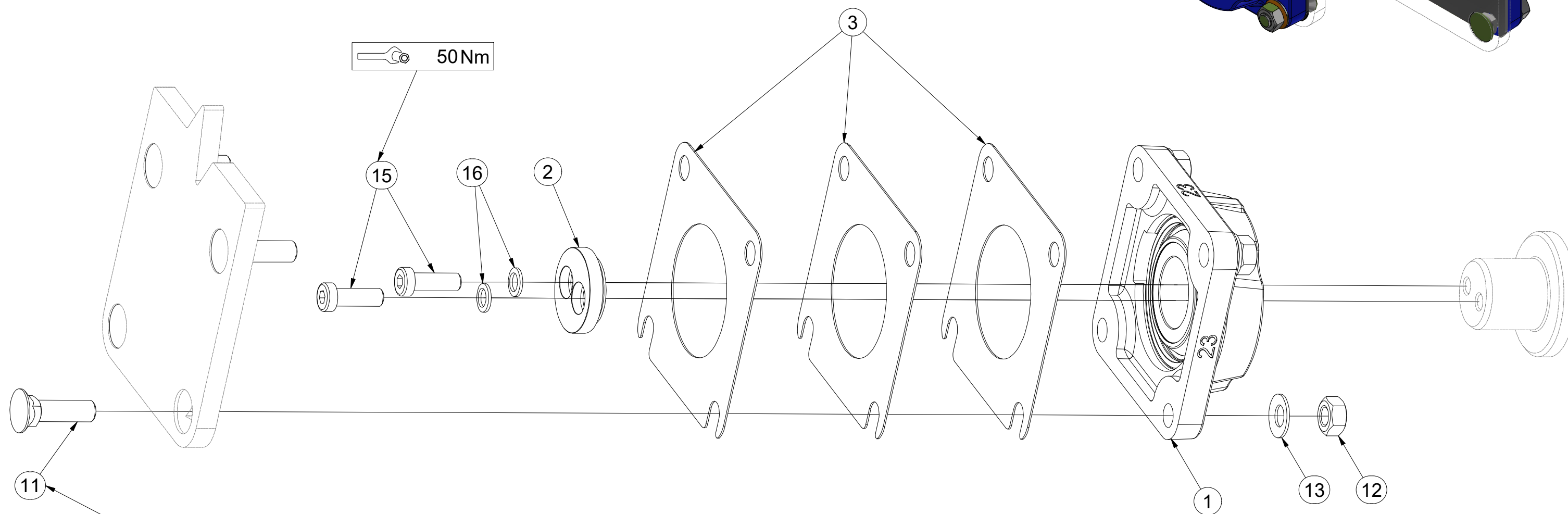
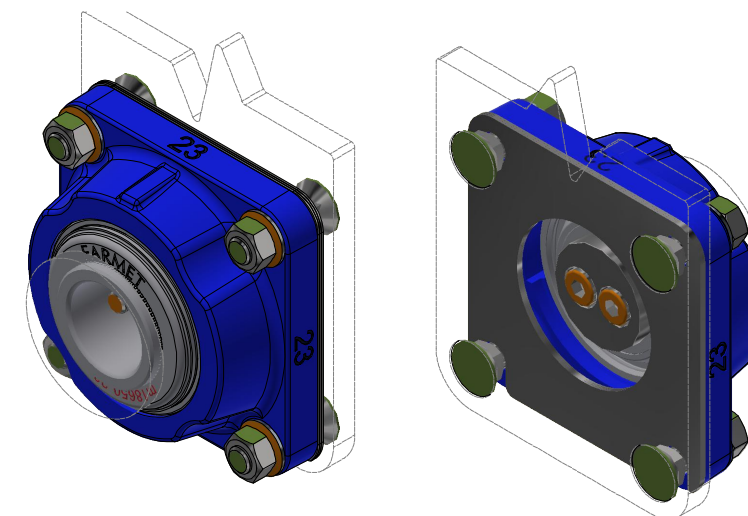

Pos.	Part Number	Pcs.
1	m18650-23	1
2	VZ00038211	1
3	4016809	3
11	m03519	4
12	m01305	4
13	m17545	4
15	m24320	2
16	m24356	2

CZ SADA LOŽISEK  
 D SATZ LAGER  
 F KIT DE ROULEMENTS

GB SET OF BEARINGS  
 RU КОМПЛЕКТ ПОДШИПНИКОВ  
 PL ZESTAW ŁOŻYSK



**VZ00040131**

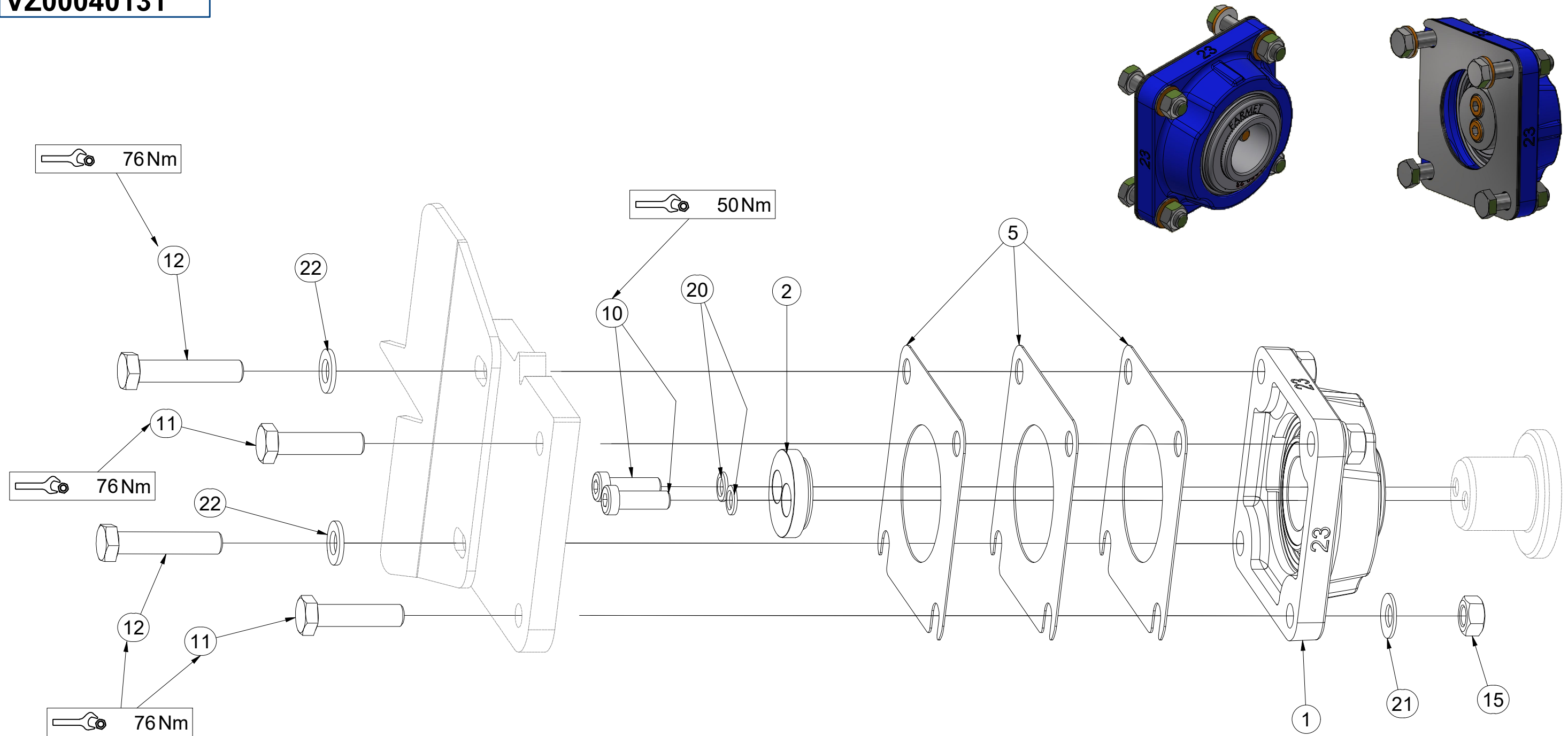

Pos.	Part Number	Pcs.
1	m18650-23	1
2	VZ00038211	1
5	4016809	3
10	m24320	2
11	m03339	2
12	m01131	2
15	m01305	4
20	m24356	2
21	m17545	4
22	m17741	2

- Ⓒ SADA LOŽISEK
- Ⓓ SATZ LAGER
- Ⓕ KIT DE ROULEMENTS

- Ⓒ SET OF BEARINGS
- Ⓔ КОМПЛЕКТ ПОДШИПНИКОВ
- Ⓖ ZESTAW ŁOŻYSK



**VZ00039821**

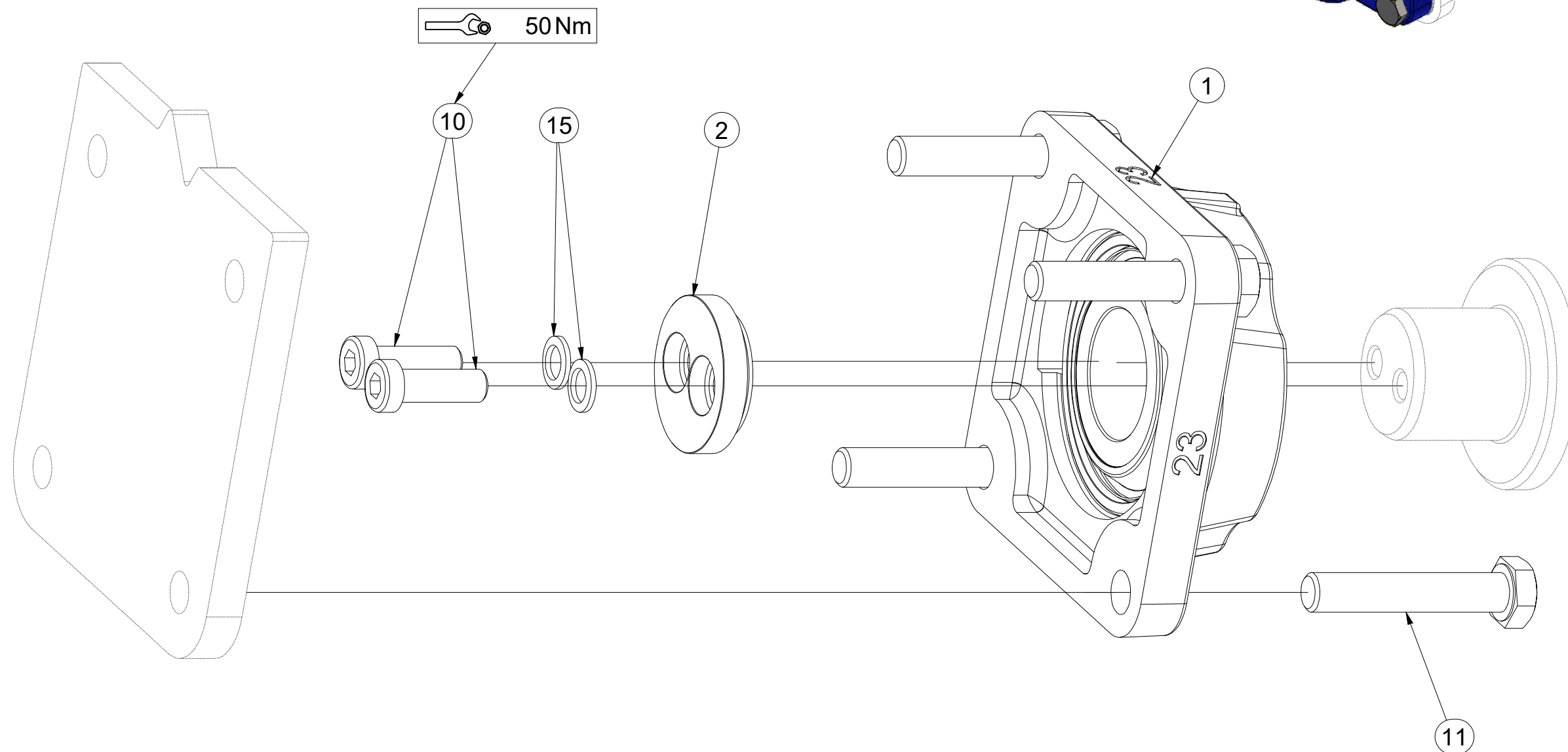
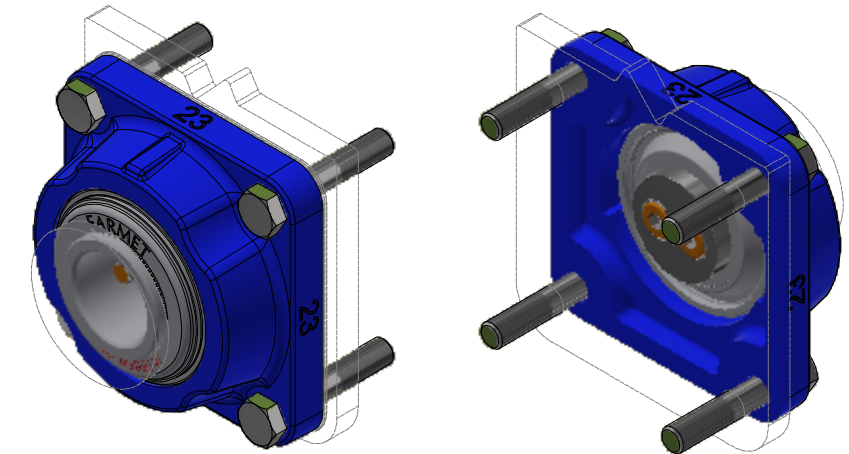

Pos.	Part Number	Pcs.
1	m18650-23	1
2	VZ00038211	1
10	m24320	2
11	m05898	4
15	m24356	2

- Ⓒ SADA LOŽISEK
- Ⓓ SATZ LAGER
- Ⓕ KIT DE ROULEMENTS

- Ⓒ SET OF BEARINGS
- Ⓔ КОМПЛЕКТ ПОДШИПНИКОВ
- Ⓖ ZESTAW ŁOŻYSK



**VZ00039820**

Pos.	Part Number	Pcs.
1	m18650-23	1
2	VZ00038211	1
10	m24320	2
15	m01305	4
21	m17545	4
20	m24356	2

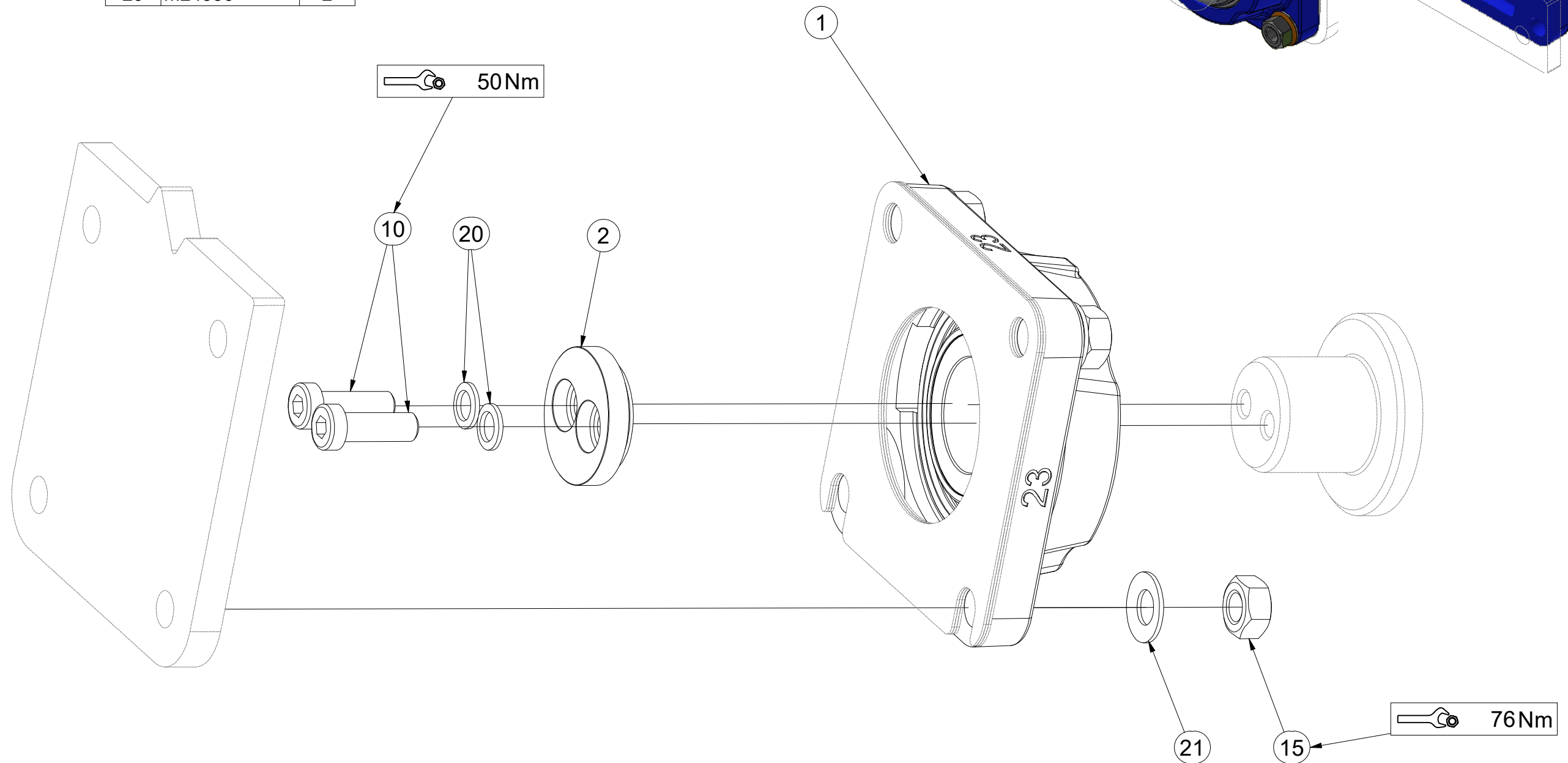
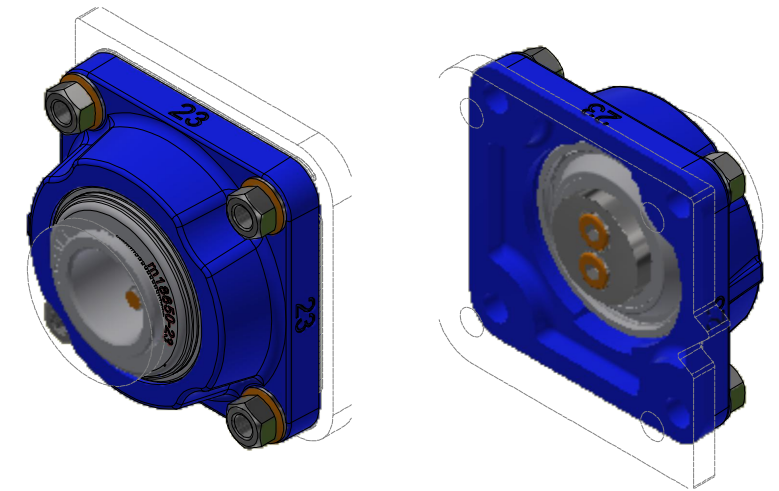

VZ00038564

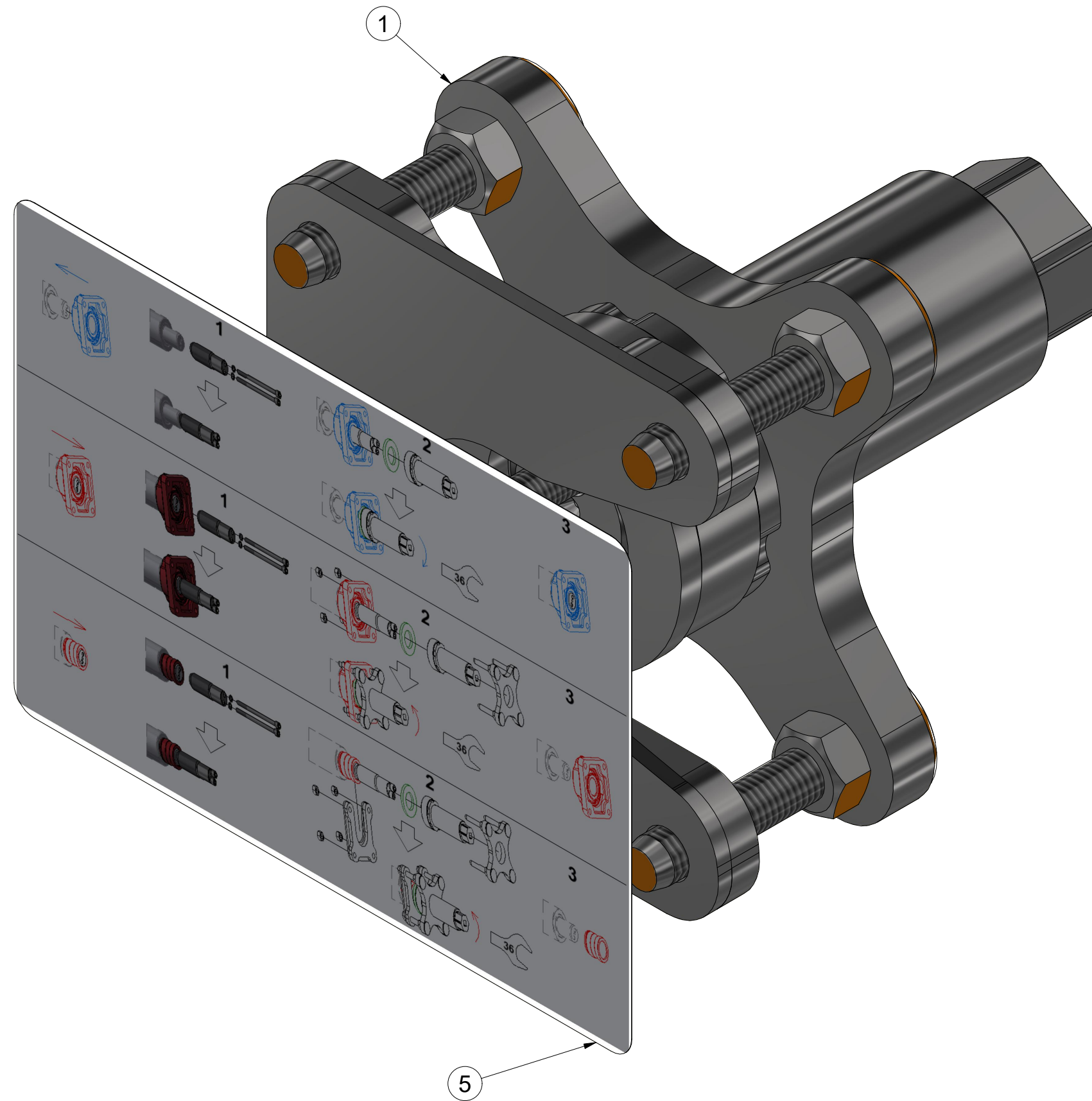

Pos.	Part Number	Pcs.
1	VZ00040530	1
5	m24596	1

VZ00040530

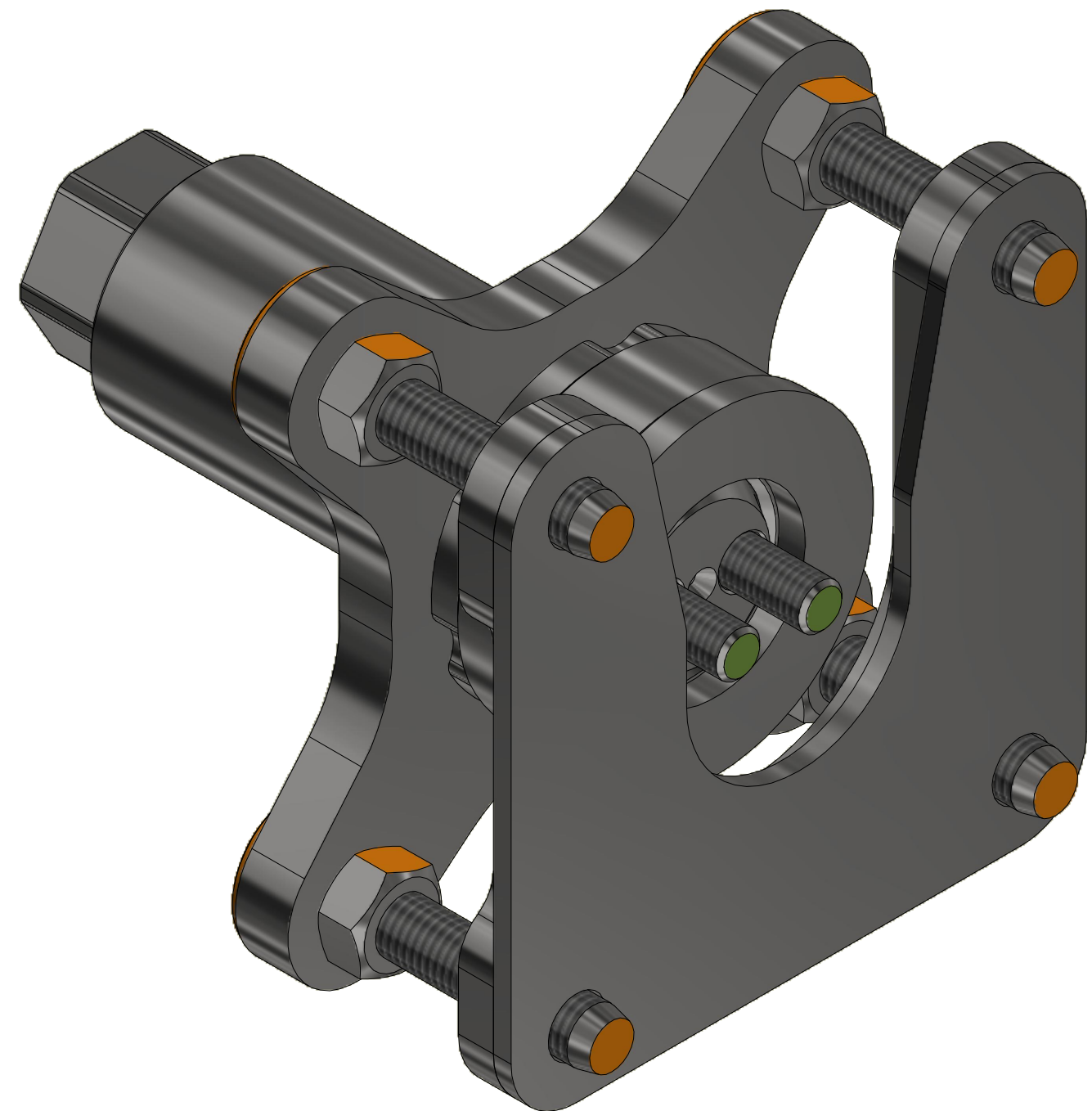
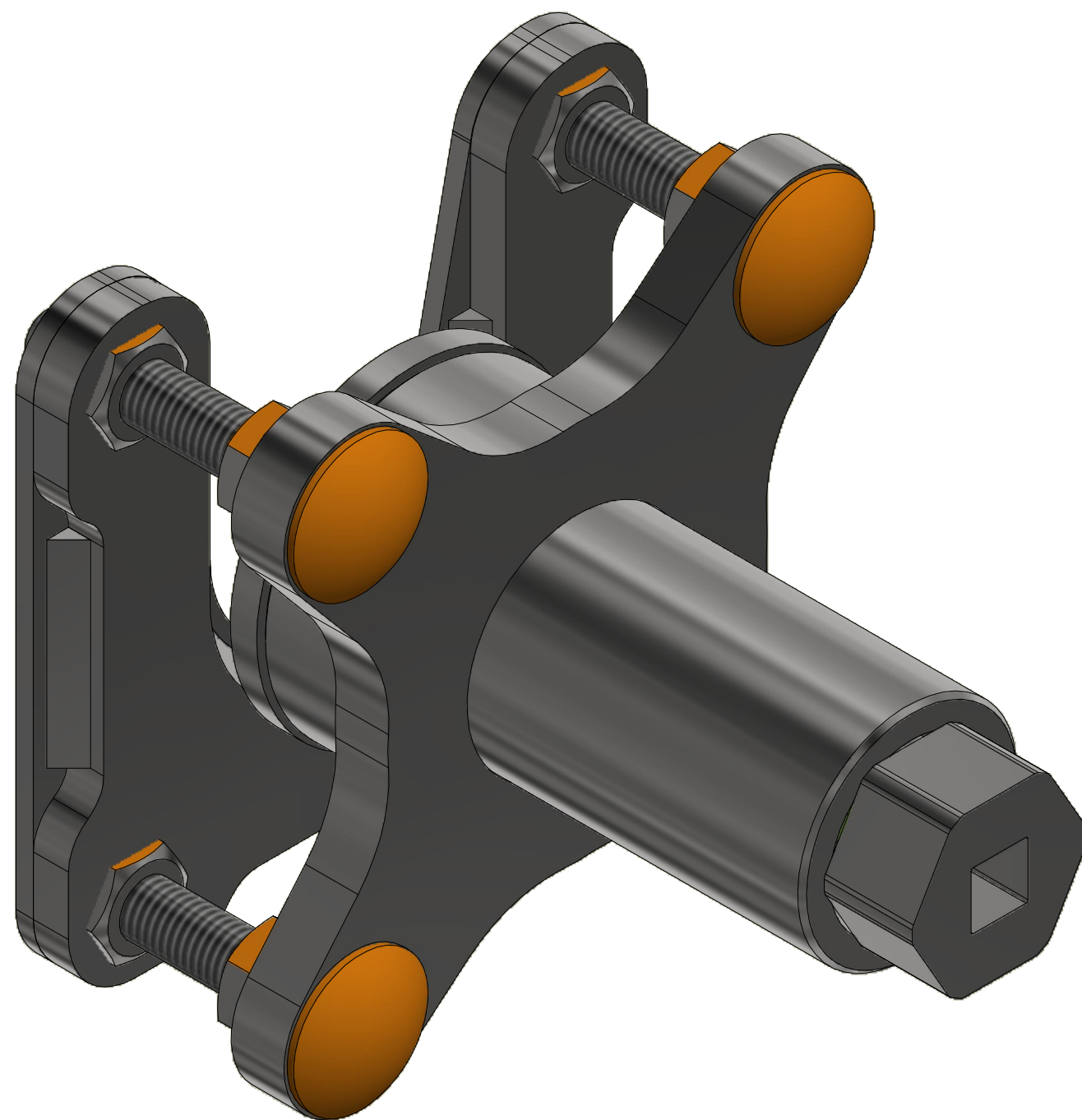

**VZ00040530**

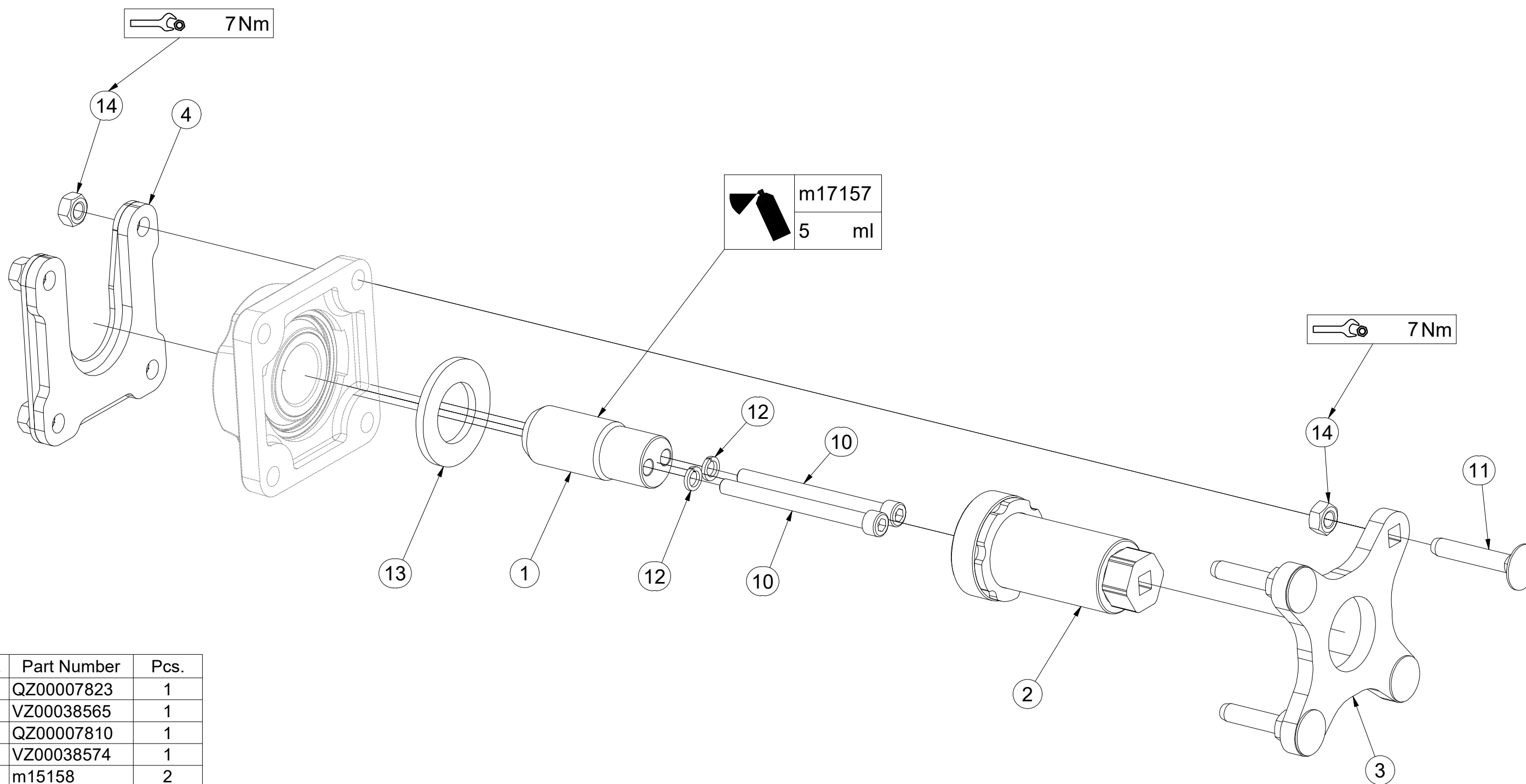

Pos.	Part Number	Pcs.
1	QZ00007823	1
2	VZ00038565	1
3	QZ00007810	1
4	VZ00038574	1
10	m15158	2
11	m17684	4
12	m01208	2
13	m03636	1
14	m10439	8
20	m17157	5,00 ml

CZ SADA NÁPRAVY  
 D SATZ AUFHÄNGUNG  
 F KIT DE L'ESSIEU

GB AXLE SET  
 RU КОМПЛЕКТ ОСИ КОЛЁС  
 PL ZESTAW OSI



**3012633**

M18x1,5-265Nm  
 280 kPa

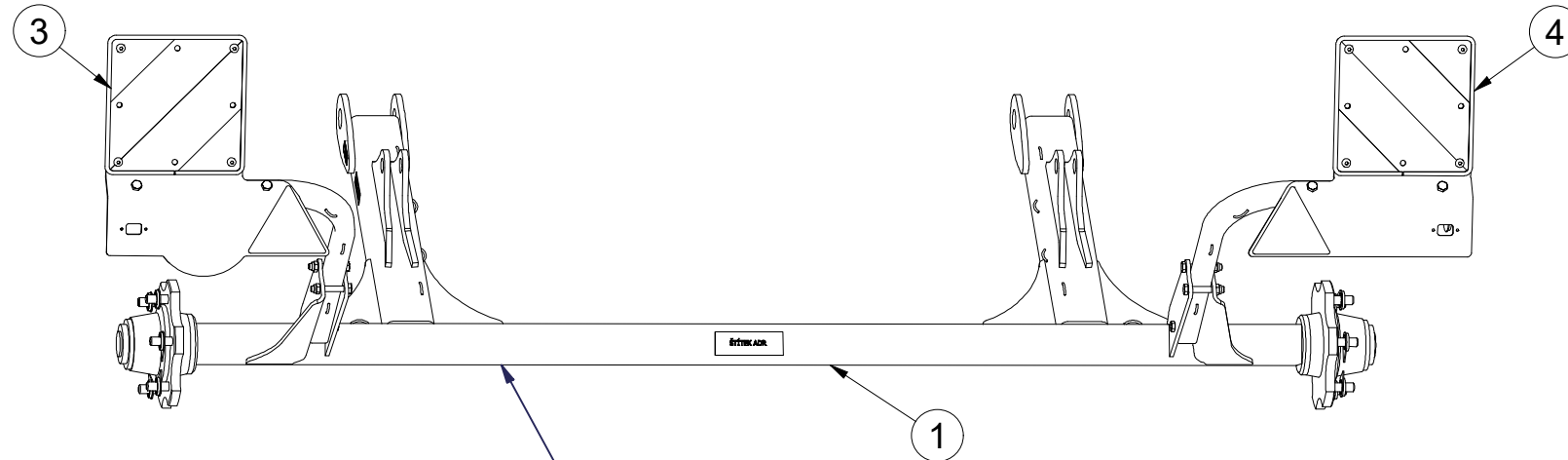

# A80RM600012

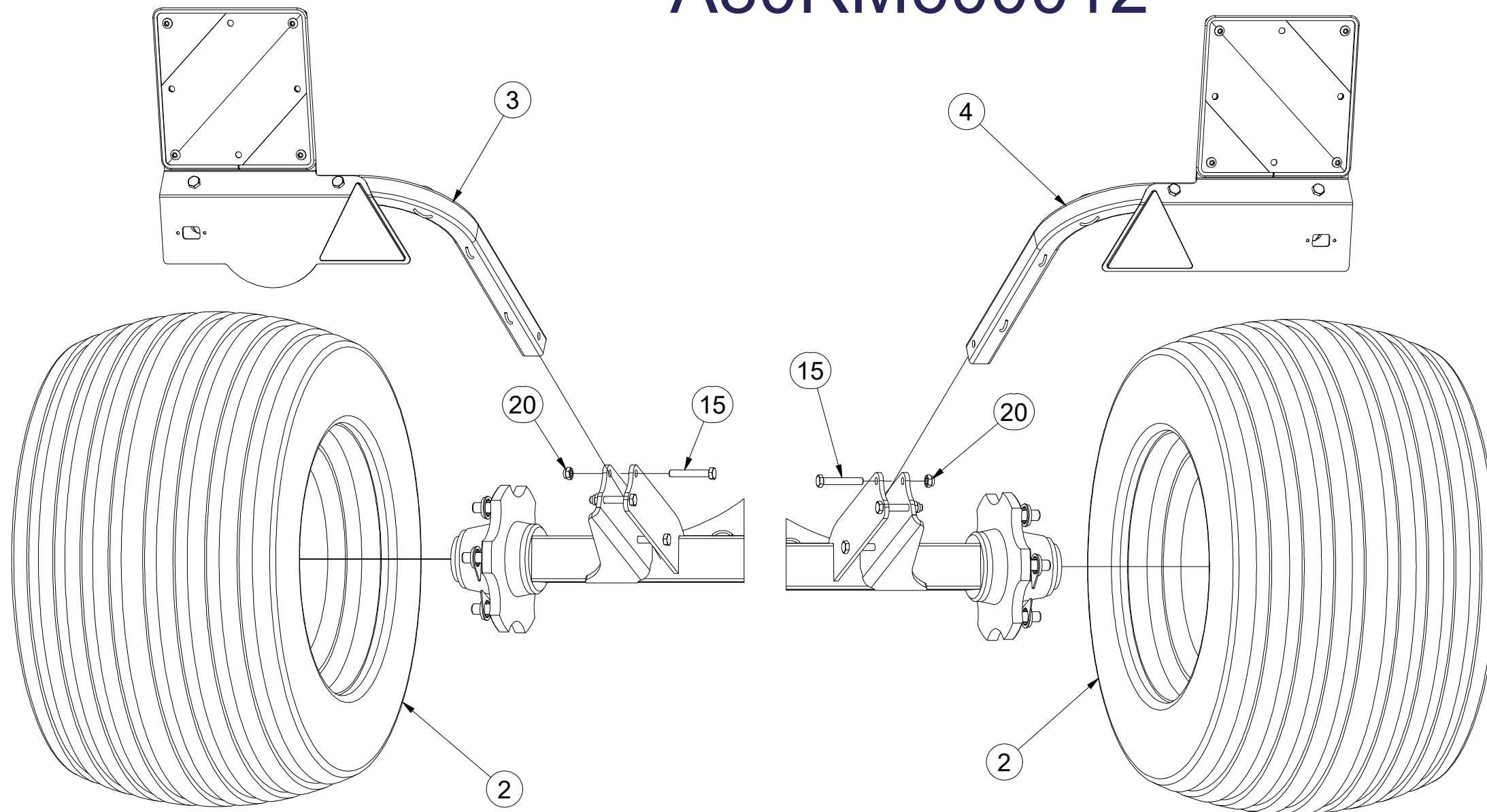
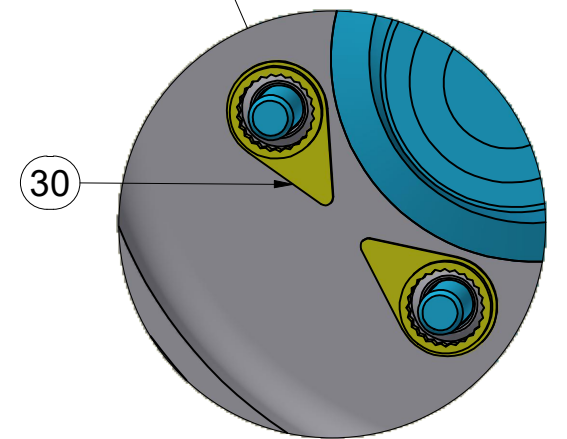
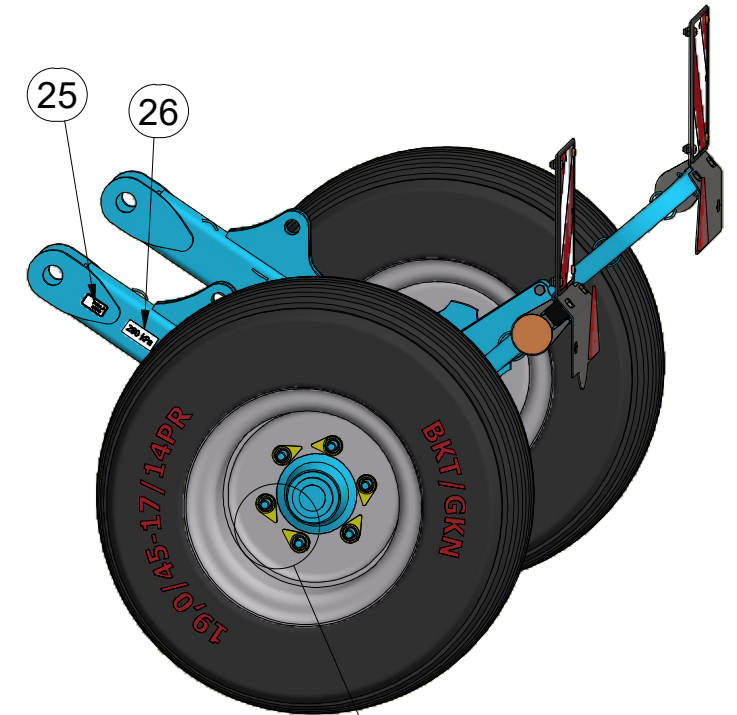

Pos.	Part Number	Pcs.
1	3012632	1
2	m19870	2
3	3012367	1
4	3012389	1
15	m12493	6
20	m04301	6
25	m19732	2
26	m21945	2
30	m19657	12



Ⓒ NÁPRAVA

Ⓓ ACHSE

Ⓕ ESSIEU

Ⓒ AXLE

Ⓓ OCB

Ⓕ OS



**A80RM60012**

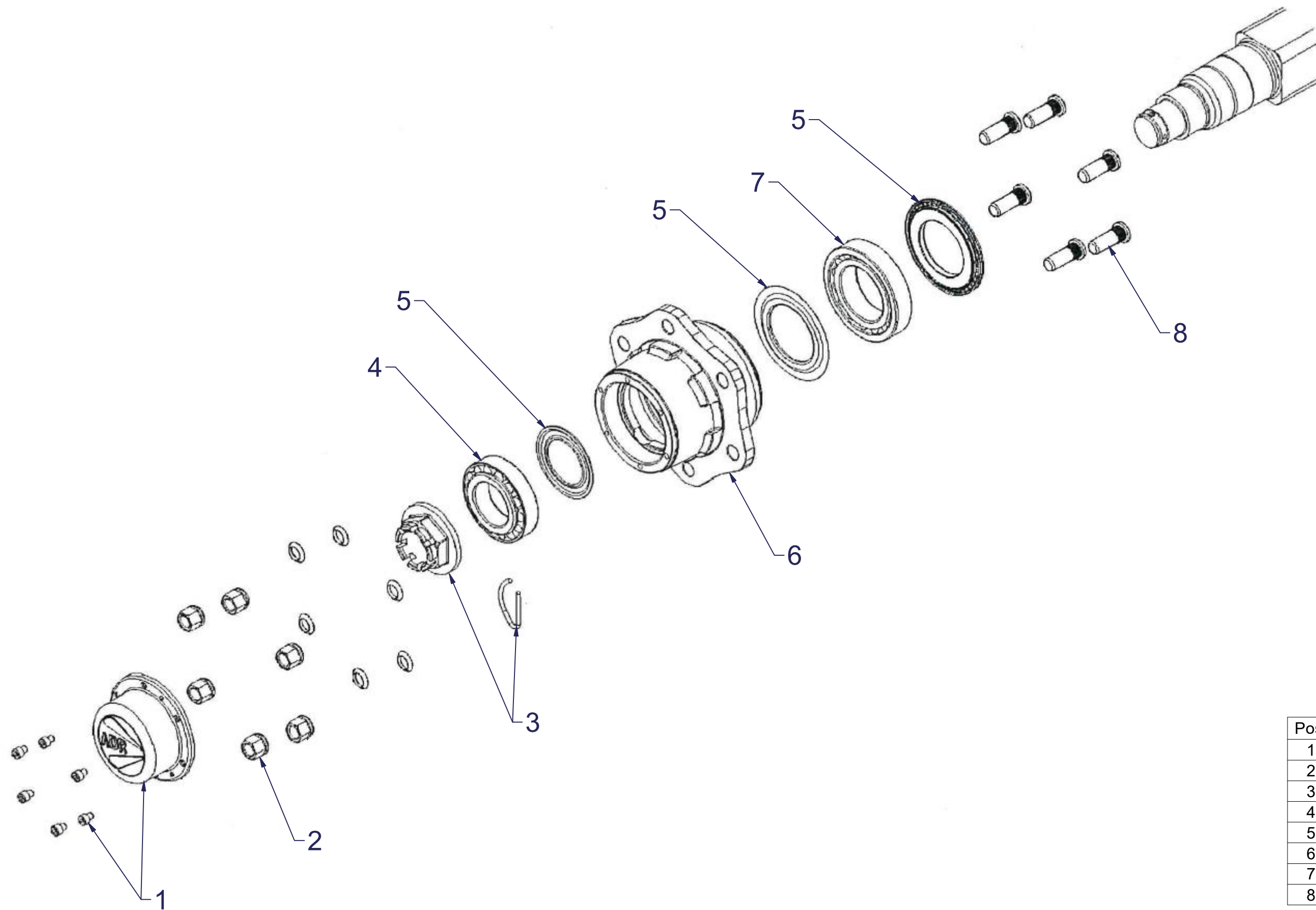

Pos.	Part Number	Pcs.
1	m12566	2
2	m08163	12
3	m08168	2
4	m07153	2
5	m08156	2
6	m12567	2
7	m07154	2
8	m08148	12

ⒸZ TERČ ZADNÍ LEVÝ

Ⓓ SCHILD, HINTERES, LINKES

Ⓕ CIBLE ARRIÈRE GAUCHE

**3012367**

ⒸB LEFT REAR DISC

ⒸU ЩИТОК ЗАДНИЙ ЛЕВЫЙ

ⒸL TARCZA TYLNA LEWA

**Farmet**

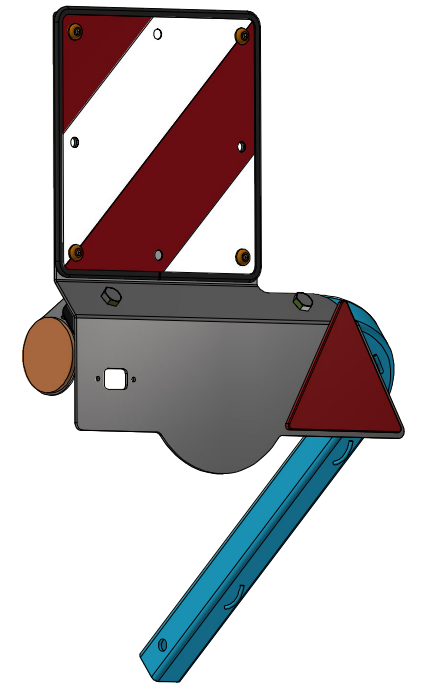
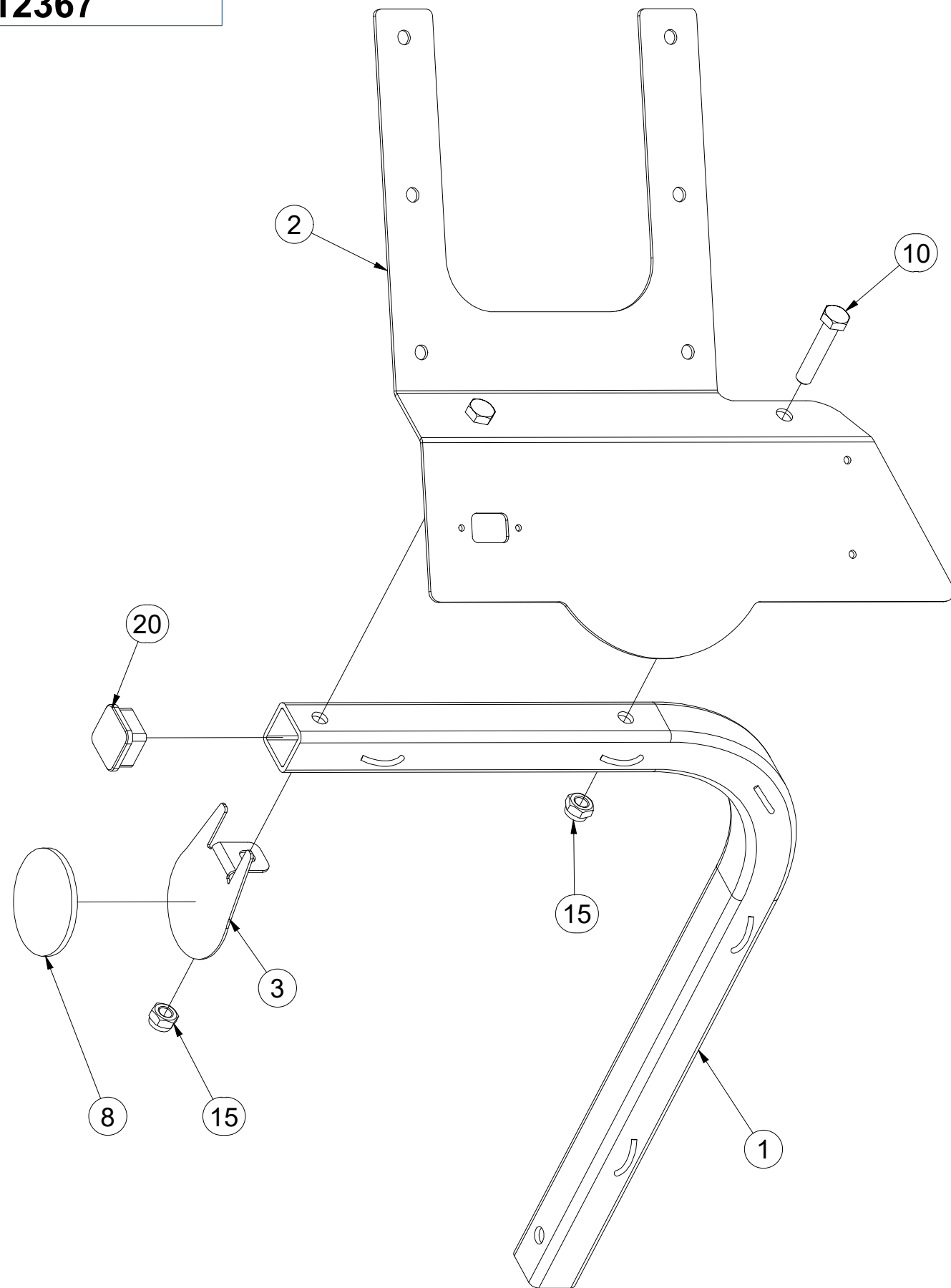

Pos.	Part Number	Pcs.
1	3012364	1
2	3012365	1
3	4024926	1
8	m02579	1
10	m01131	2
15	m04301	2
20	m12689	1

ⒸZ TERČ ZADNÍ LEVÝ

Ⓓ SCHILD, HINTERES, LINKES

Ⓕ CIBLE ARRIÈRE GAUCHE

ⒼB LEFT REAR DISC

ⒶU ЩИТОК ЗАДНИЙ ЛЕВЫЙ

ⒶL TARCZA TYLNA LEWA



**3012367**

Pos.	Part Number	Pcs.
5	m18855	1
6	9005707	1
7	m02497	1
11	m16637	4
16	m03775	4
25	m01209	4

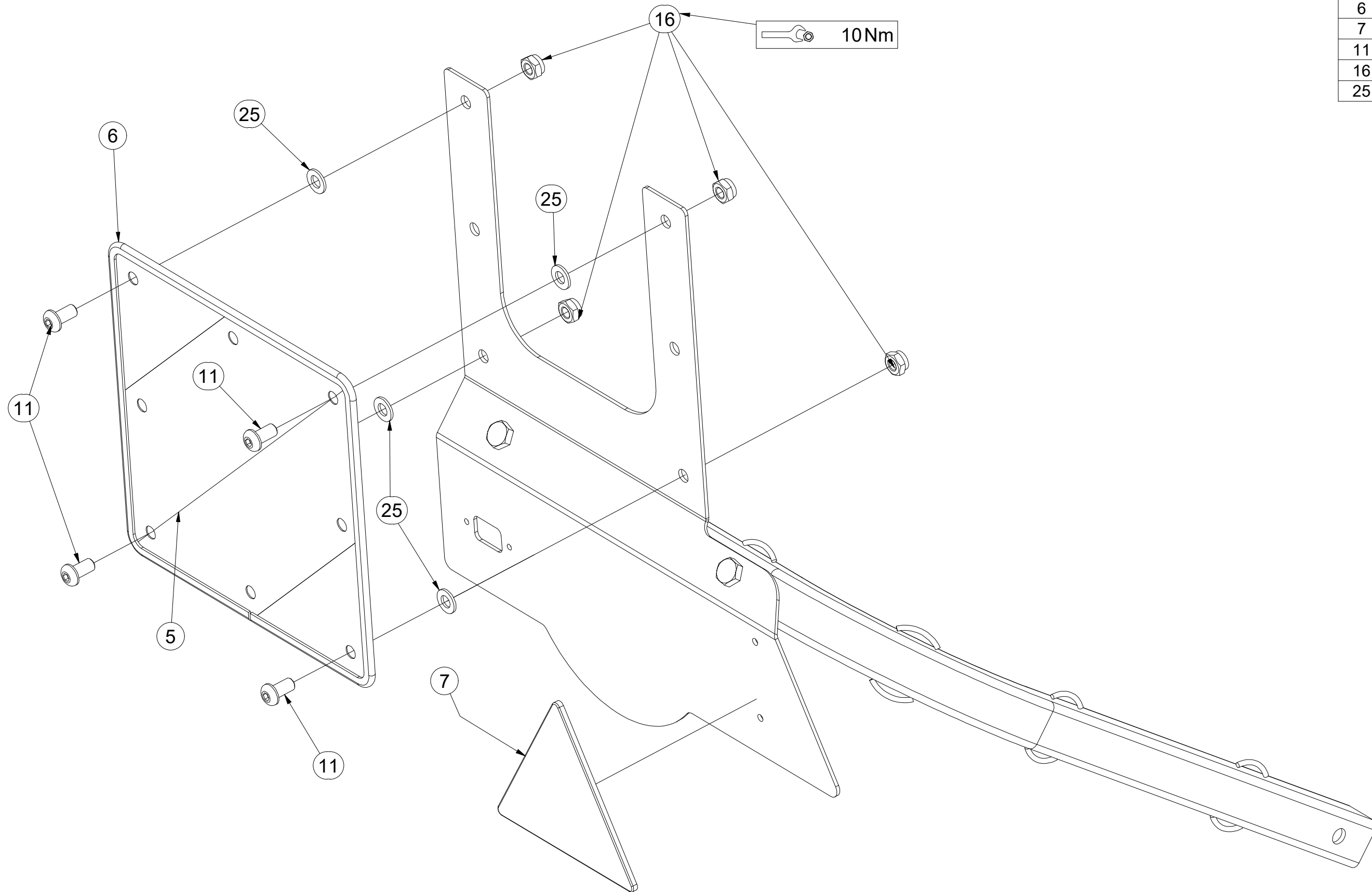

ⒸZ TERČ ZADNÍ PRAVÝ

Ⓓ SCHILD, HINTERES, RECHTES

Ⓕ CIBLE ARRIÈRE DROITE

**3012389**

ⒼB RIGHT REAR DISC

ⒺЩИТОК ЗАДНИЙ ПРАВЫЙ

ⒽL TARCZA TYLNA PRAWA

**Farmet**

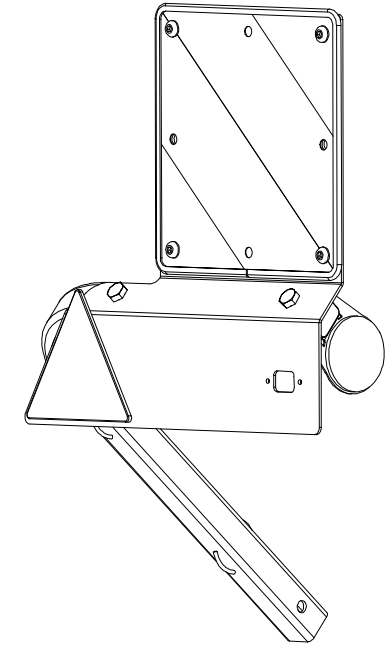
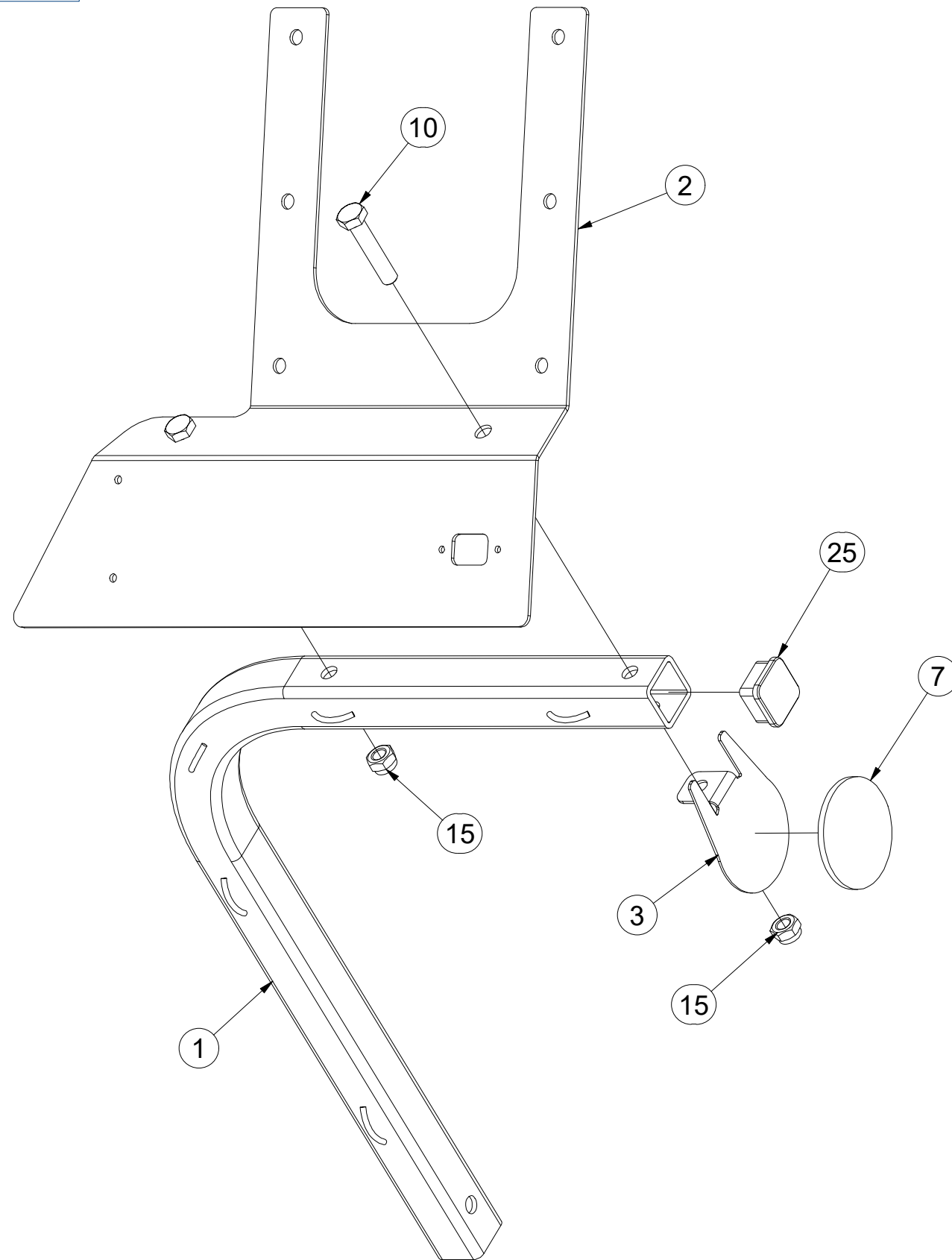

Pos.	Part Number	Pcs.
1	3012364	1
2	3012390	1
3	4024926	1
7	m02579	1
10	m01131	2
15	m04301	2
25	m12689	1

ⒸZ TERČ ZADNÍ PRAVÝ

Ⓓ SCHILD, HINTERES, RECHTES

Ⓕ CIBLE ARRIÈRE DROITE

ⒼB RIGHT REAR DISC

ⒶU ЩИТОК ЗАДНИЙ ПРАВЫЙ

ⒶL TARCZA TYLNA PRAWA

**Farmet**

**3012389**

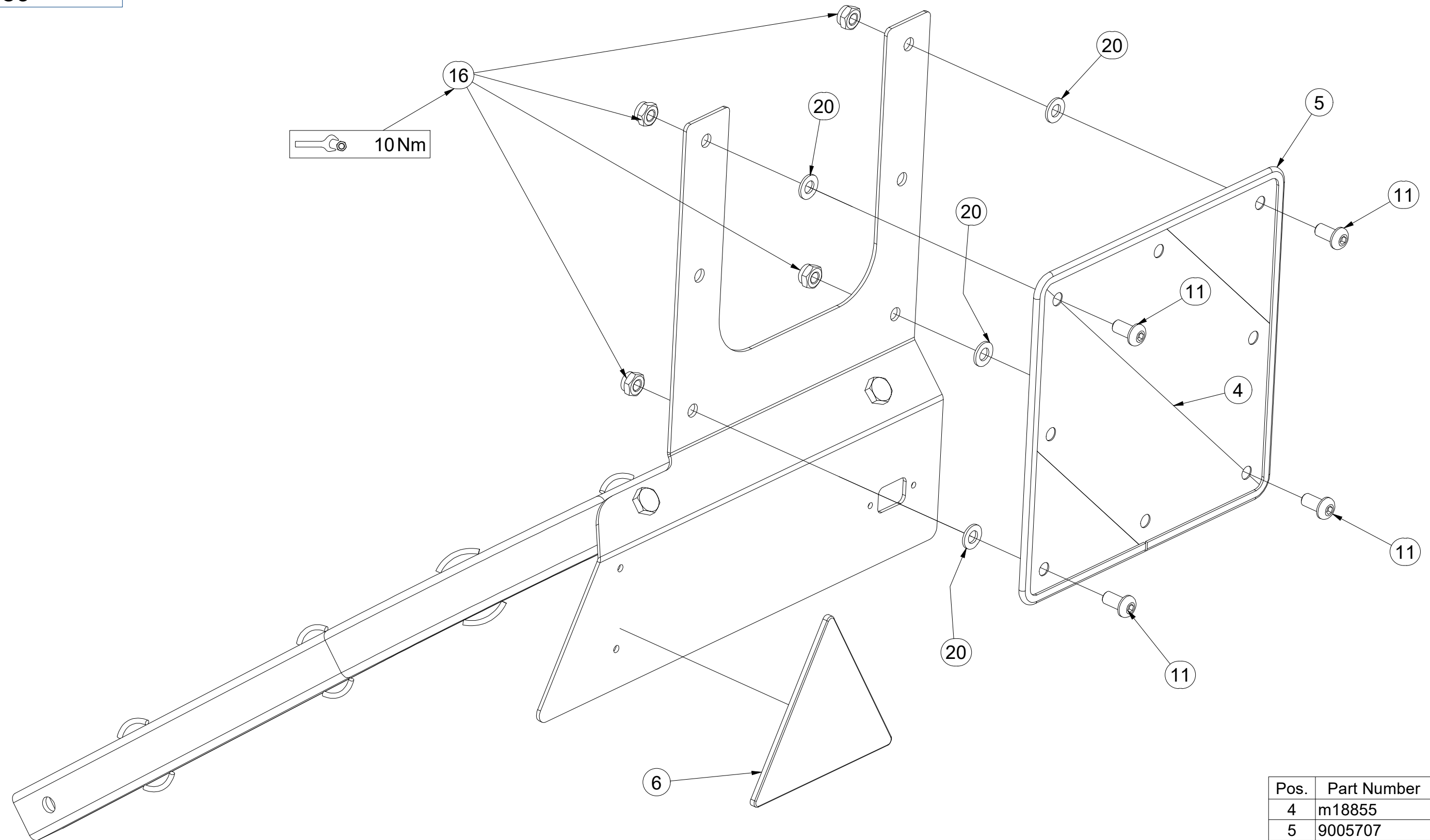

Pos.	Part Number	Pcs.
4	m18855	1
5	9005707	1
6	m02497	1
11	m16637	4
16	m03775	4
20	m01209	4

Ⓒ SAMOLEPKY STROJE

Ⓓ AUFKLEBER MASCHINEN

Ⓕ VOITURE MACHINES

Ⓖ STICKERS MACHINES

Ⓡ СТИКЕРЫ МАШИНЫ

Ⓟ NAKLEJKI MASZYNY



**4026236**

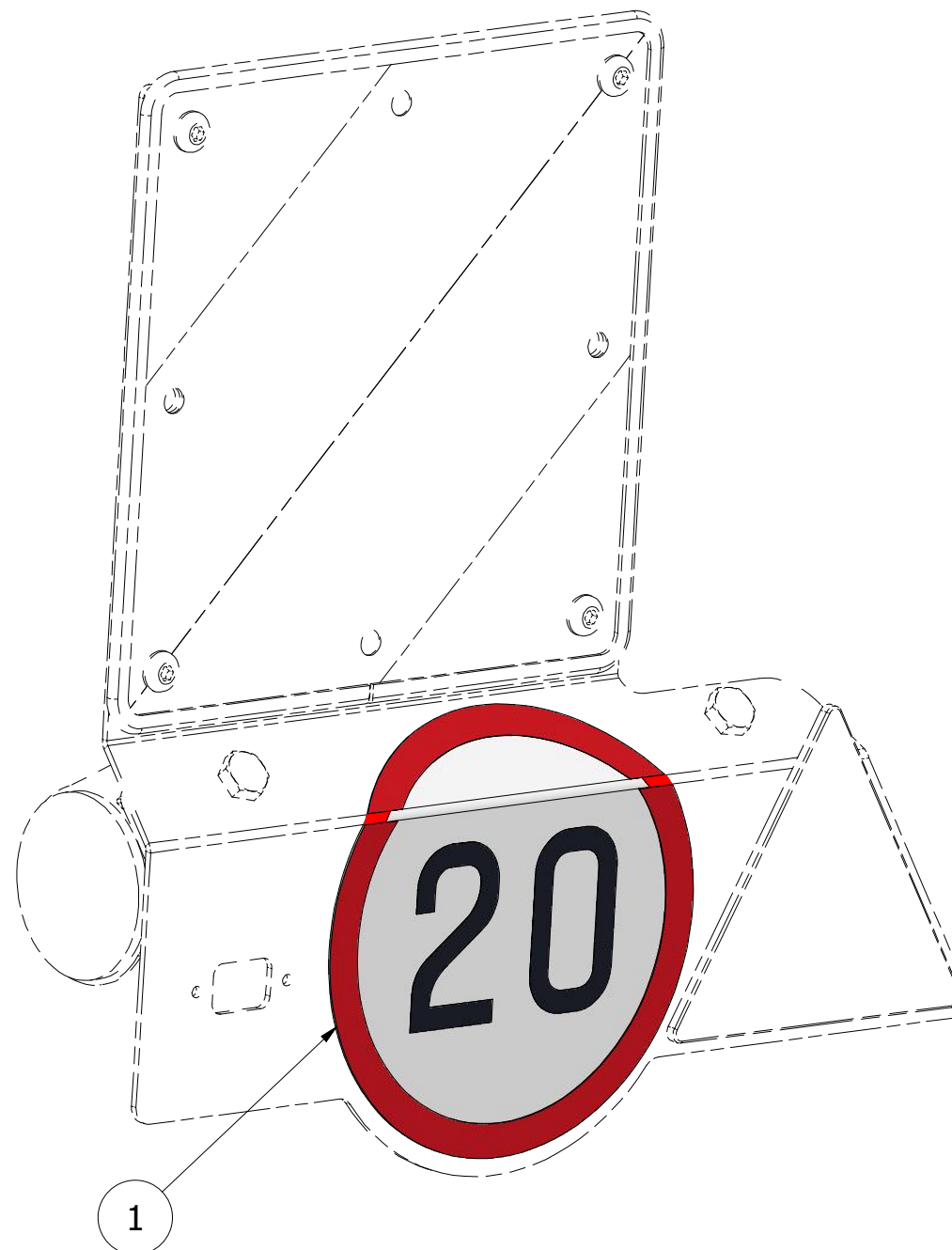

Pos.	Part Number	Pcs.
1	m04406	1

Ⓒ SOUPRAVA TĚSNIVA PÍSTNIC

Ⓓ KOLBENSTANGENDICHTUNGSMITTELSATZ

Ⓕ SET DE GARNITURE DES TIGES DE PISTON

Ⓖ SEALING SET FOR PISTON RODS

Ⓡ КОМПЛЕКТ ПРОКЛАДОК ЦИЛИНДРОВ

Ⓟ ZESTAW USZCZELEK TRZPIENIA TŁOKA



1



VZ00024031 - Ø80/Ø40-250		
Pos	Part number	Pcs
1	m20702	1

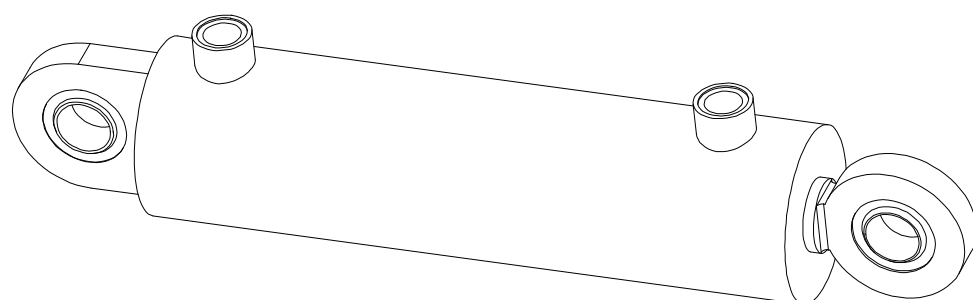

2



VZ00004549 - Ø80/Ø40-250		
Pos	Part number	Pcs
2	m20702	2

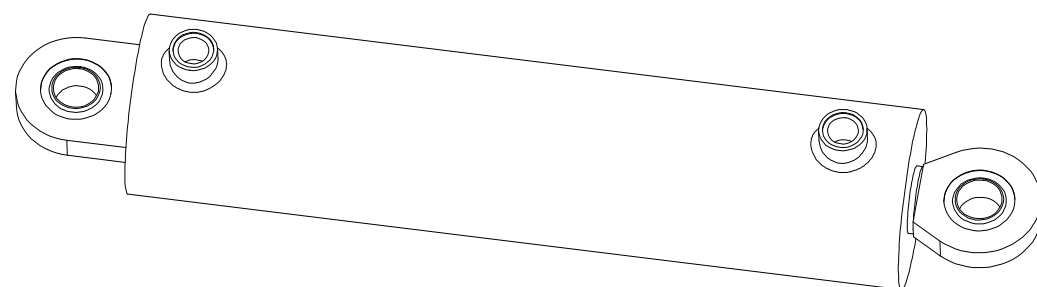

3



VZ00013004 - Ø100/Ø45-400		
Pos	Part number	Pcs
3	m22614	2

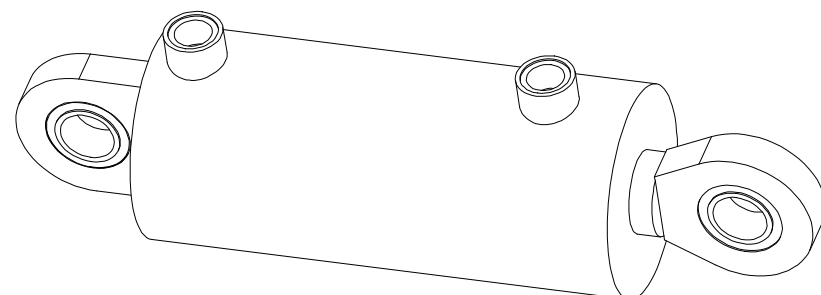

4



VZ00018175 - Ø100/Ø45-160		
Pos	Part number	Pcs
4	m22614	1

Ⓒ SVĚTELNÁ SADA

Ⓓ LEUCHTENSATZ

Ⓕ KIT LUMINEUX

Ⓖ LIGHTING SET

Ⓡ ОСВЕТИТЕЛЬНЫЙ КОМПЛЕКТ

Ⓟ ZESTAW OŚWIETLENIA



**3012429**

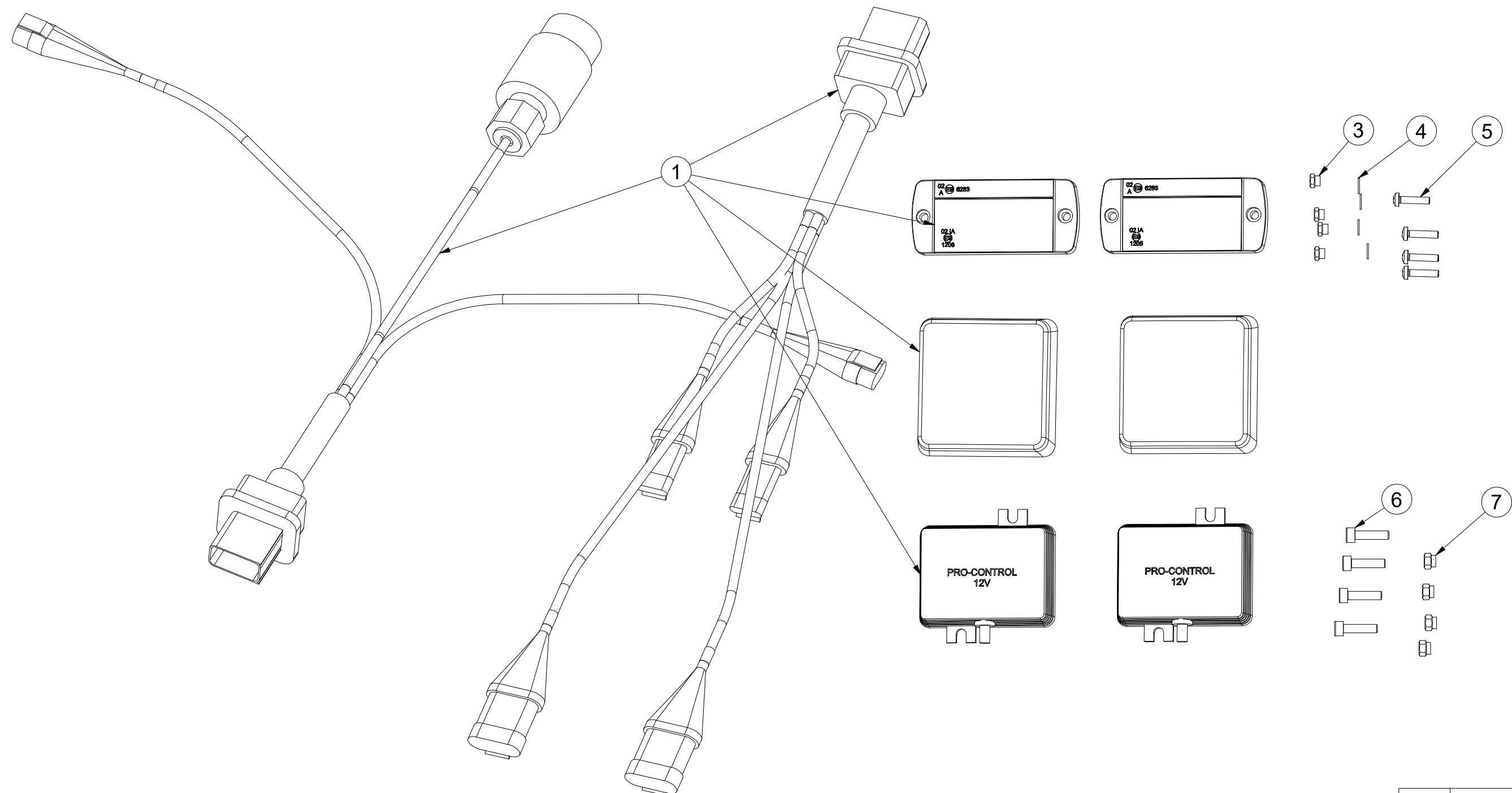

Pos.	Part Number	Pcs.
1	m19043	1
3	m05562	4
4	m05597	4
5	m15790	4
6	m10591	4
7	m06236	4



Ⓒ SVĚTELNÁ SADA

Ⓓ LEUCHTENSATZ

Ⓕ KIT LUMINEUX

Ⓒ LIGHTING SET

Ⓒ ОСВЕТИТЕЛЬНЫЙ КОМПЛЕКТ

Ⓒ ZESTAW OŚWIETLENIA



**3012429**

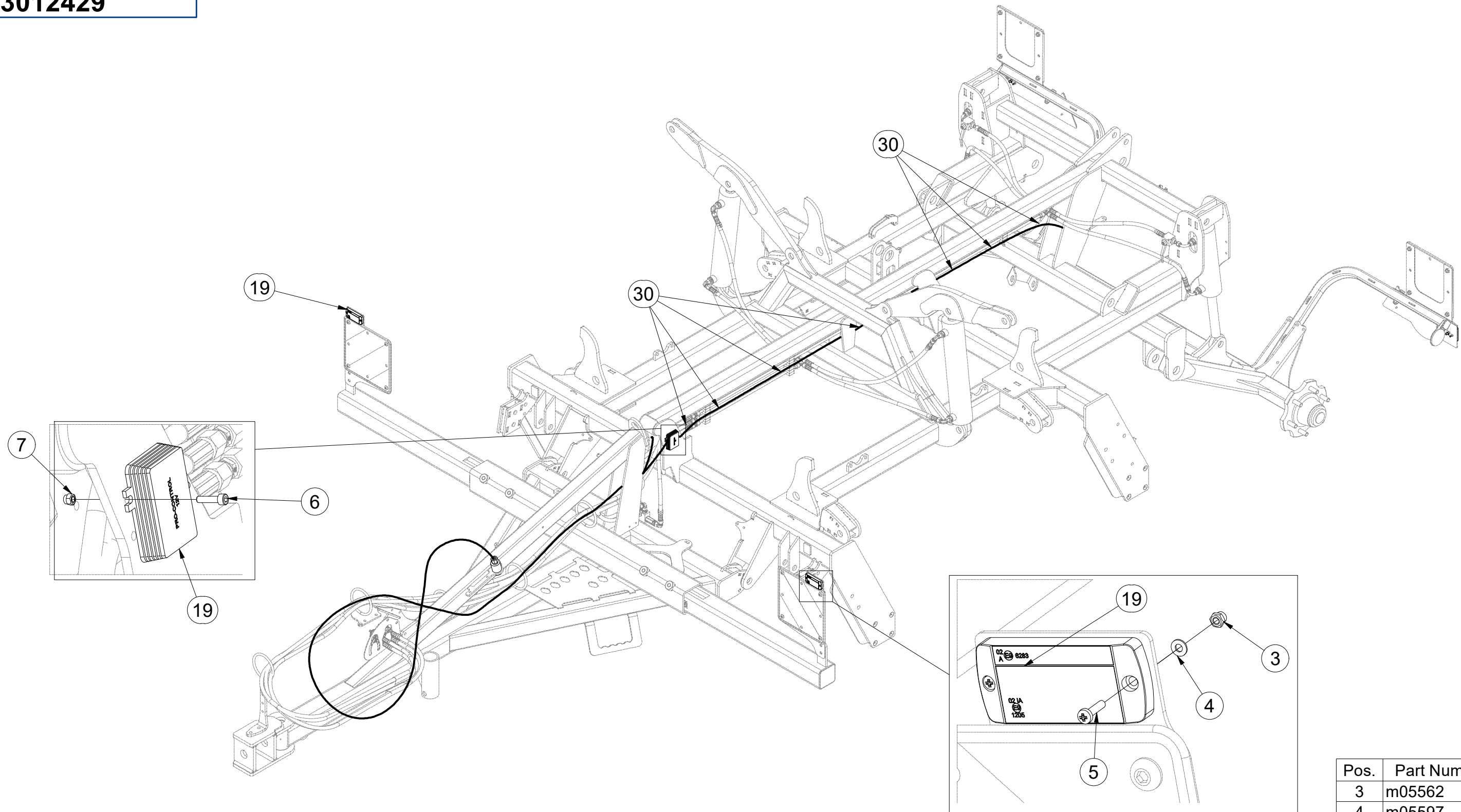

Pos.	Part Number	Pcs.
3	m05562	4
4	m05597	4
5	m15790	4
6	m10591	4
7	m06236	4
19	m19043	1
30	m05566	50

Ⓒ SVĚTELNÁ SADA

Ⓓ LEUCHTENSATZ

Ⓕ KIT LUMINEUX

Ⓖ LIGHTING SET

Ⓡ ОСВЕТИТЕЛЬНЫЙ КОМПЛЕКТ

Ⓟ ZESTAW OŚWIETLENIA

**Farmet**

**3012429**

Pos.	Part Number	Pcs.
19	m19043	1
30	m05566	50

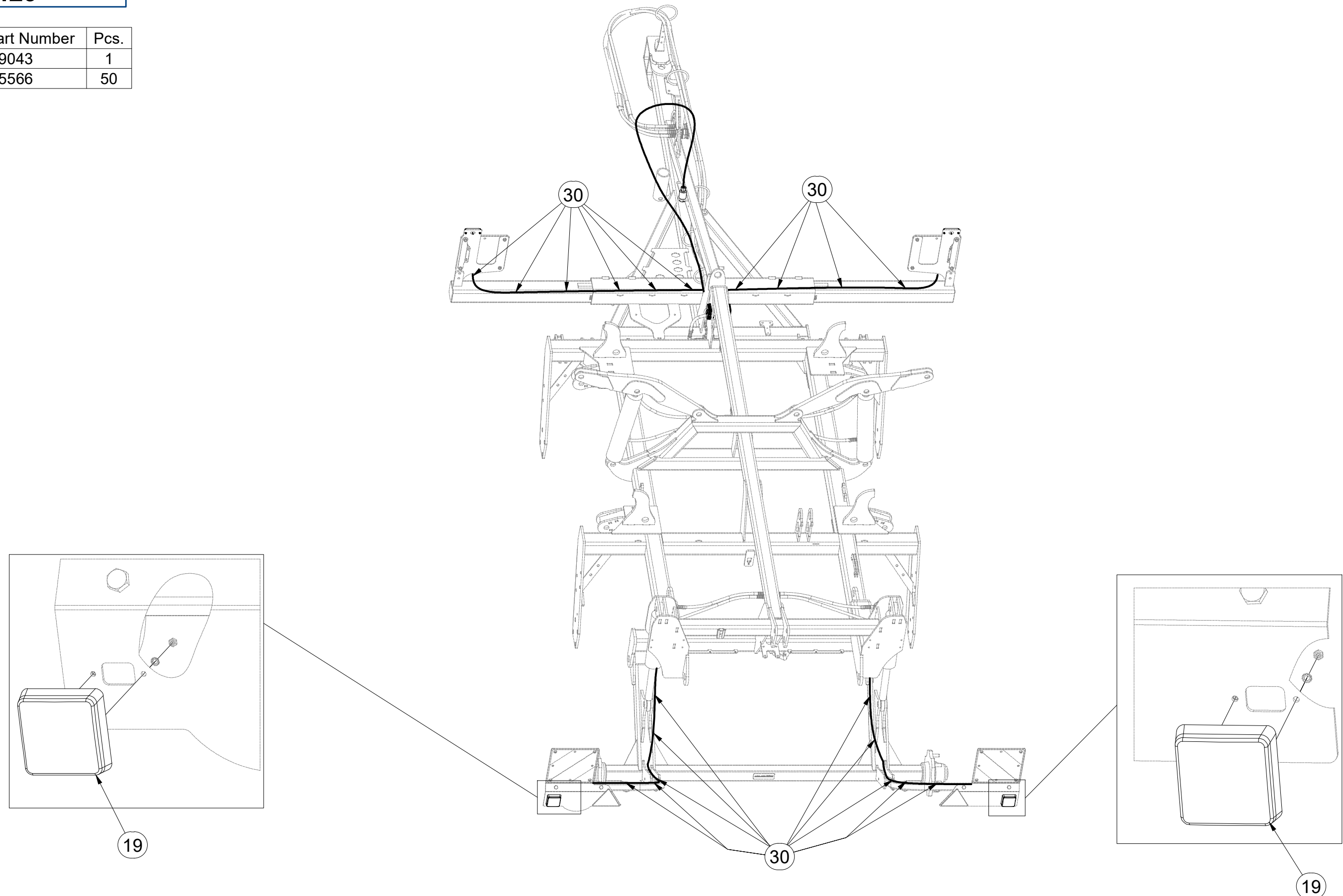

Ⓒ SVĚTELNÁ SADA

Ⓓ LEUCHTENSATZ

Ⓕ KIT LUMINEUX

Ⓖ LIGHTING SET

Ⓡ ОСВЕТИТЕЛЬНЫЙ КОМПЛЕКТ

Ⓟ ZESTAW OŚWIETLENIA

**Farmet**

**m19043**

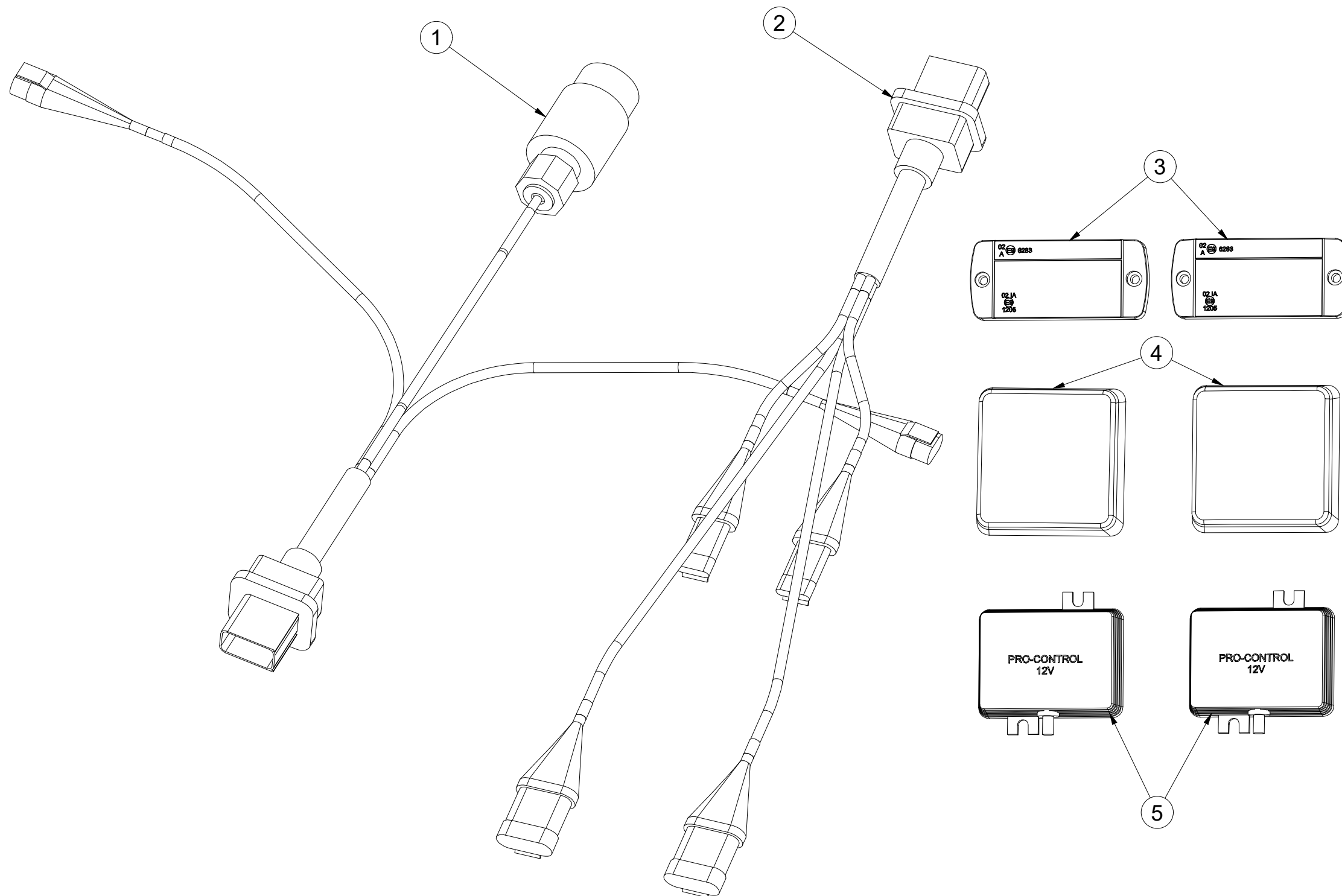

Pos.	Part Number	Pcs.
1	m14779	1
2	m14778	1
3	m14776	2
4	m19044	2
5	m14777	2

- Ⓒ UTAHOVACÍ MOMENTY ŠROUBŮ  
 Ⓓ ANZUGMOMENTE VON SCHRAUBEN  
 Ⓕ COUPLES DE SERRAGE DES VIS

- Ⓒ SCREW TIGHTENING TORQUE  
 Ⓓ МОМЕНТЫ ЗАЖАТИЯ БОЛТОВ  
 Ⓕ MOMENTY DOKRĘCANIA ŚRUB



P		5.8	8.8	10.9	12.9	Z	
D	R	Mu	Mu	Mu	Mu	DIN 7991	ISO 10642
mm	mm	Nm	Nm	Nm	Nm	Nm	Nm
M6	1	6	9	13	15	7,2	7,9
M8	1,25	14	22	32	38	17	19
M10	1,5	29	44	64	75	35	38
M12	1,75	49	76	111	130	58	65
M14	2	79	120	176	206	93	100
M16	2	123	188	276	323	144	158
M18	2,5	169	257	378	443	-	220
M20	2,5	239	365	536	628	-	310
M22	2,5	329	529	738	864	-	420
M24	3	413	629	924	1082	-	530
M27	3	613	934	1372	1606	-	-
M30	3,5	832	1267	1862	2179	-	-
M33	3,5	1130	1723	2530	2961	-	-
M36	4	1451	2210	3246	3799	-	-
M39	4	1885	2872	4217	4936	-	-
M42	4,5	2322	3538	5196	6080	-	-
M45	4,5	2909	4433	6511	7619	-	-
M48	5	3513	535	7862	9200	-	-
M52	5	4524	6895	10123	11849	-	-
M56	5,5	5636	8589	12614	14761	-	-

- Mu - Ⓒ UTAHOVACÍ MOMENT  
 Ⓓ ANZUGMOMENTE  
 Ⓕ COUPLE DE SERRAGE  
 Ⓒ TIGHTENING TORQUE  
 Ⓓ МОМЕНТ ЗАЖАТИЯ  
 Ⓕ MOMENT DOKRĘCANIA
- D - Ⓒ JMENOVITÝ PRŮMĚR  
 Ⓓ NENNDURCHMESSER  
 Ⓕ DIAMETRE NOMINAL  
 Ⓒ NOMINAL DIAMETER  
 Ⓓ НОМИНАЛЬНЫЙ ДИАМЕТР  
 Ⓕ ŚREDNICA NOMINALNA
- R - Ⓒ ROZTEČ ZÁVITU - STOUPÁNÍ  
 Ⓓ GEWINDESTEIGUNG  
 Ⓕ PAS DE FILET - PAS  
 Ⓒ SCREW PITCH – LEAD  
 Ⓓ ШАГ РЕЗЬБЫ  
 Ⓕ ROZSTAW GWINTU - SKOKI
- P - Ⓒ PEVNOST  
 Ⓓ FESTIGKEIT  
 Ⓕ RÉSISTANCE  
 Ⓒ STRENGTH  
 Ⓓ ПРОЧНОСТЬ  
 Ⓕ WYTRZYMA OŚĆ
- Z - Ⓒ ZÁPUSTNÉ ŠROUBY  
 Ⓓ SENKKOPFSCHRAUBEN  
 Ⓕ VIS A TETE FRAISEE  
 Ⓒ COUNTERSUNK SCREWS  
 Ⓓ БОЛТЫ С УТОПЛЕННОЙ ГОЛОВКОЙ  
 Ⓕ ŚRUBY Z ŁBEM STOŻKOWYM PŁASKIM

- Ⓒ Hodnoty momentů jsou poníženy o -10% oproti tabulkovým hodnotám. Šroubové spoje utahujte dle vyznačeného utahovacího momentu v dokumentaci. Pokud není utahovací moment v dokumentaci vyznačen, utahujte dle obecné tabulky. Pokud je v dokumentaci definován spoj šroubu a matice o různých pevnostech, vždy utahujte na moment komponenty nižší.
- Ⓓ Die Werte der Anzugsmomente sind um 10 % gegenüber den Tabellenwerten verringert. Ziehen Sie die Schraubverbindungen gemäß dem in der Dokumentation festgeschrieben Anzugsmoment an. Sofern das Anzugsmoment nicht in der Dokumentation aufgeführt ist, ziehen Sie sie gemäß der allgemeinen Tabelle an. Wenn in der Dokumentation eine Verbindung von Schraube und Mutter mit verschiedene Festigkeiten definiert ist, wird immer mit dem Moment des Bauteils mit der geringeren Festigkeit angezogen.
- Ⓕ Les valeurs des couples de serrage sont baissées de 10% par rapport aux valeurs de tableau. Serrez les raccords à vis selon le couple de serrage indiqué dans les documents. Si le couple de serrage n'est pas indiqué dans les documents, serrez selon le tableau général. Si les documents définissent un assemblage par boulon de diverses résistances, serrez toujours au moment de la composante avec résistance inférieure.
- Ⓒ The torque values are reduced by 10% compared to the table values. Tighten the screw joints according to the tightening torque stated in the documentation. If the tightening torque is not stated in the documentation, tighten according to the general table. If there is a joint with a screw and a nut at different strengths in the documentation, always tighten to the torque of the component with lower strength.
- Ⓓ Значения моментов затяжки уменьшены на 10% по сравнению с данными в таблице. Резьбовые соединения зажимайте с установленным в документации моментом зажатия. Если в документации не указан момент зажатия, то зажимайте по действующей в общем таблице. Если в документации установлено соединение из болта и гайки различной прочности, всегда зажимайте с моментом для компонента с меньшей прочностью.
- Ⓕ Wartości momentów dokręcania są obniżone o 10% w stosunku do wartości z tabeli. Połączenia śrubowe należy dokręcać zgodnie z momentem obrotowym w dokumentacji. Jeśli w dokumentacji nie ma podanego momentu obrotowego, należy dokręcać zgodnie z ogólną tabelą. Jeśli w dokumentacji zdefiniowane jest połączenie ze śrubą nakrętką różnych wytrzymałościach, zawsze należy dokręcać zachowując moment dokręcania komponentu z niższą wytrzymałością.

- Ⓒ UTAHOVACÍ MOMENTY ŠROUBŮ  
 Ⓓ ANZUGMOMENTE VON SCHRAUBEN  
 Ⓕ COUPLES DE SERRAGE DES VIS

- Ⓖ SCREW TIGHTENING TORQUE  
 Ⓡ MOMENTY ZAJATIA BOLTOB  
 Ⓟ MOMENTY DOKRĘCANIA ŚRUB



- Ⓒ **OBECNÝ PŘEDPIS UTAHOVÁNÍ ZAJIŠTĚNÍ ČEPOVÝCH SPOJŮ:**  
 Ⓓ **ALLGEMEINE VORSCHRIFT FÜR DAS ANZIEHEN VON BOLZENVERBINDUNGEN:**  
 Ⓕ **CONSIGNE GENERALE POUR LE SERRAGE DES ARTICULATIONS CYLINDRIQUES:**  
 Ⓖ **GENERAL INSTRUCTION FOR TIGHTENING THE SECURING OF PIN JOINTS:**  
 Ⓡ **ОБЩЕЕ ОПИСАНИЕ ЗАЖАТИЯ ПРЕДОХРАНЕНИЯ СОЕДИНЕНИЙ ПАЛЬЦАМИ:**  
 Ⓟ **OGÓLNE ZASADY DOKRĘCANIA ZABEZPIECZENIA POŁĄCZEŃ CZOPEM:**



**X**

M8, M10, M12

M14

**M**

09-15Nm

15-25Nm

- X - Ⓒ ROZMĚR ŠROUBU  
 Ⓓ SCHRAUBENGRÖSSE  
 Ⓕ DIMENSIONS DE LA VIS

- Ⓖ BOLT DIMENSION  
 Ⓡ РАЗМЕР БОЛТА  
 Ⓟ ROZMIAR ŚRUBY

- M - Ⓒ ORIENTAČNÍ MOMENT  
 Ⓓ ANZUGSMOMENT  
 Ⓕ COUPLE D'ORIENTATION

- Ⓖ ORIENTATION TORQUE  
 Ⓡ ОРИЕНТАЦИОННЫЙ МОМЕНТ  
 Ⓟ ORIENTACYJNY MOMENT

- Ⓒ Tyto spoje není nutné ověřovat kontrolou momentovým klíčem = stačí vizuálně kontrolovat sešroubování.  
 Ⓓ Diese Verbindungen müssen nicht mit einem Drehmomentschlüssel überprüft werden = es genügt, die Verschraubung visuell zu kontrollieren.  
 Ⓕ Il n'est pas nécessaire de contrôler le serrage à l'aide d'une clé dynamométrique = un contrôle visuel de l'assemblage suffit.  
 Ⓖ These joints do not have to be verified by checking with a torque wrench = visual inspection of bolting is sufficient.  
 Ⓡ Эти соединения не нужно контролировать динамометрическим ключом = достаточно визуально проверять прикручивание.  
 Ⓟ Nie trzeba sprawdzać tych połączeń kluczem dynamometrycznym = wystarczy wizualnie skontrolować dokręcenie.