

ⒸZ KATALOG NÁHRADNÍCH DÍLŮ ⒸB CATALOGUE OF SPARE PARTS ⒸD ERSATZTEILLISTE
ⒸRU КАТАЛОГ ЗАПАСНЫХ ЧАСТЕЙ ⒸF CATALOGUE DES PIÈCES DE RECHANGE ⒸPL KATALOG CZĘŚCI ZAMIENNYCH

КОМПАКТМАТ K600PS

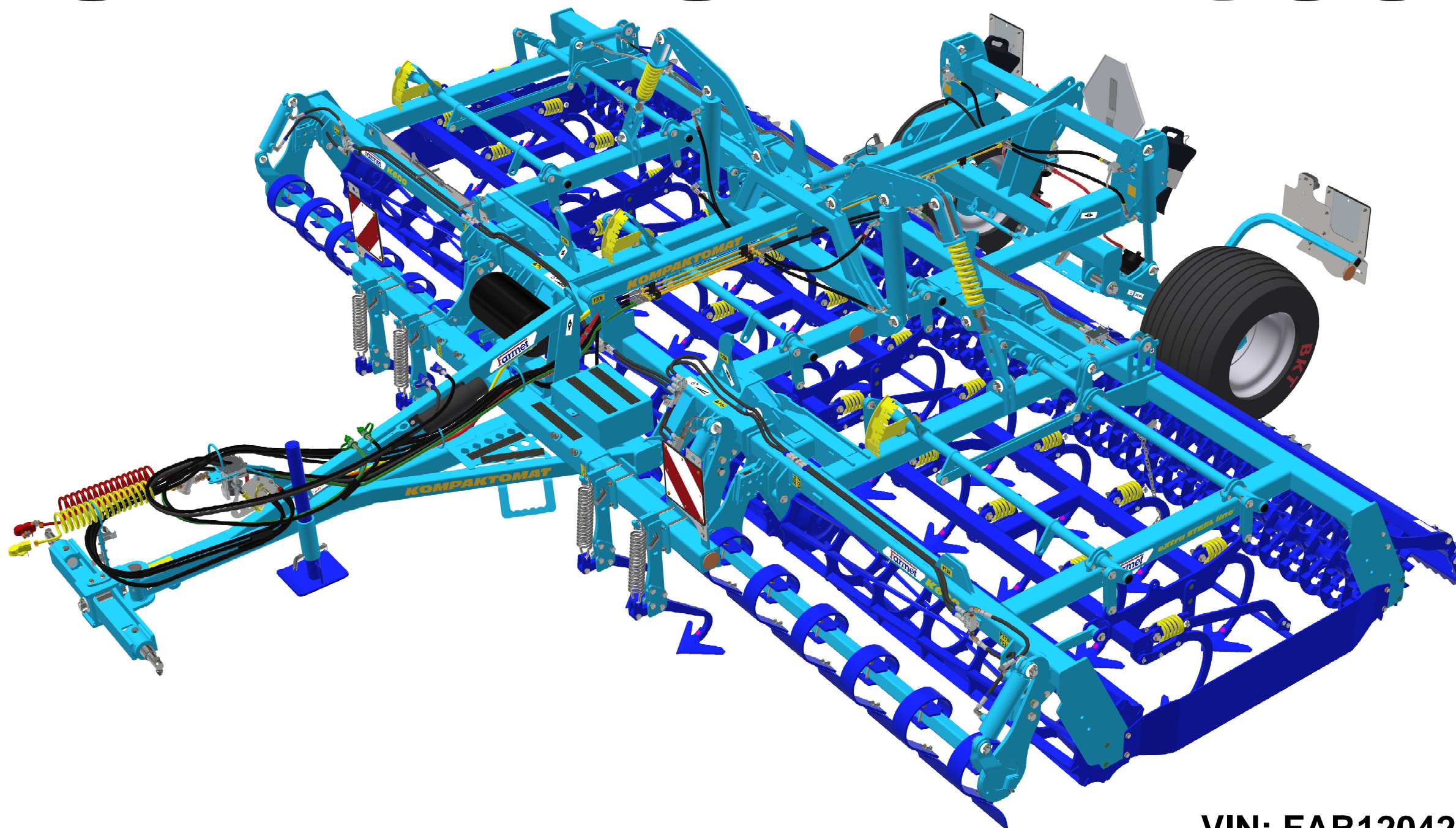

ⒸZ Platnost pro vrcholové | výrobní číslo stroje ⒸB Validity for the top | serial number of the machine
ⒸD Gültigkeit für die Haupt- | Herstellungsnummer der Maschine ⒸRU Действительно для главного | заводского номера машины
ⒸF Validité du numéro de référence | de série de la machine ⒸPL Obowiązuje dla numeru głównego | seryjnego maszyny

VIN: FAR12042VR0000306
9333862 | 2024/0306

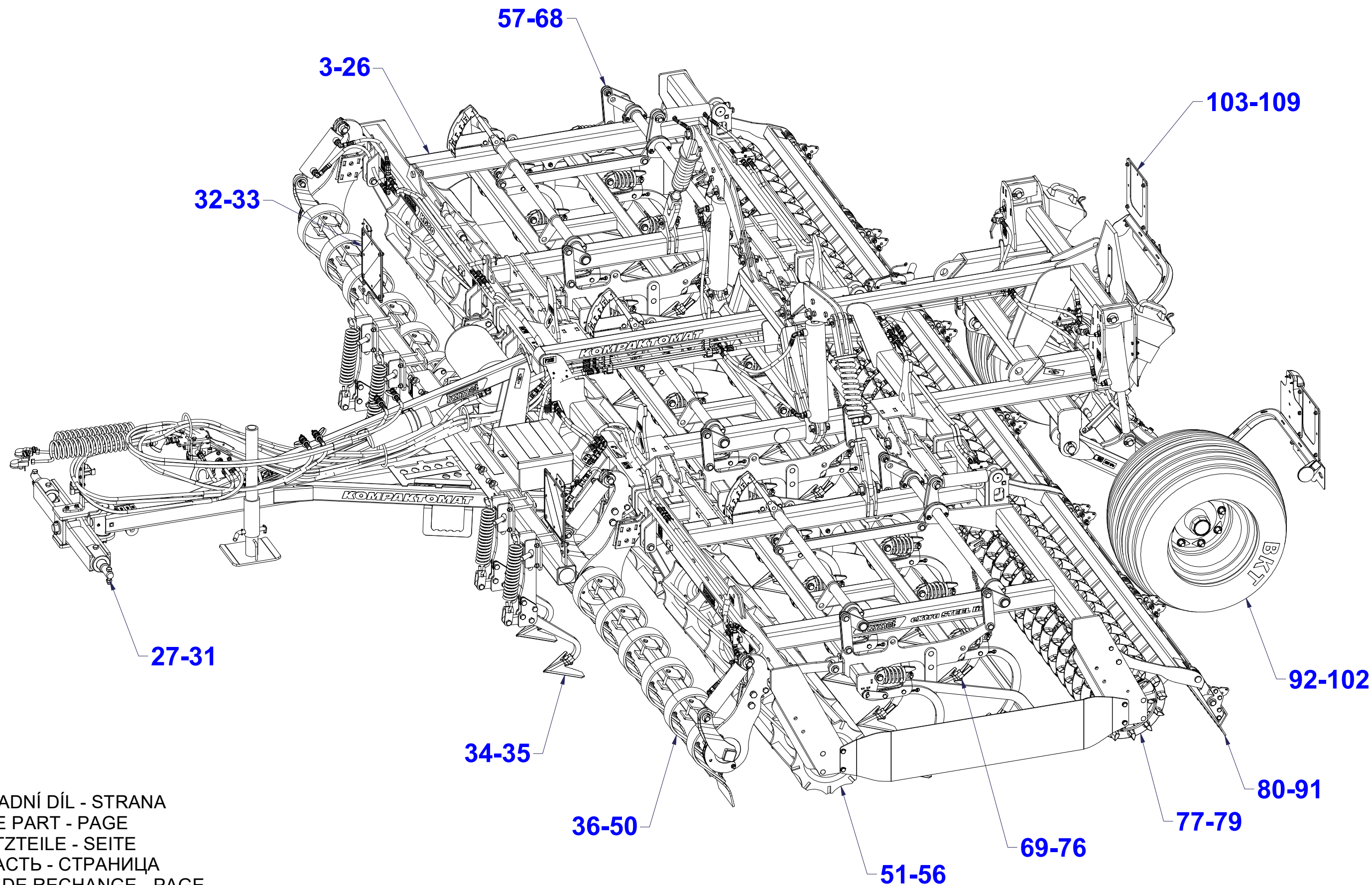

☉ POLOTOVAR STROJE

☐ MASCHINEN-HALBFABRIKAT

☐ MACHINE - SEMI-PRODUIT

☉ SEMIFINISHED MACHINE

☐ ПОЛУФАБРИКАТ МАШИНЫ

☐ PÓLFABRYKAT MASZYNY



VZ00018740

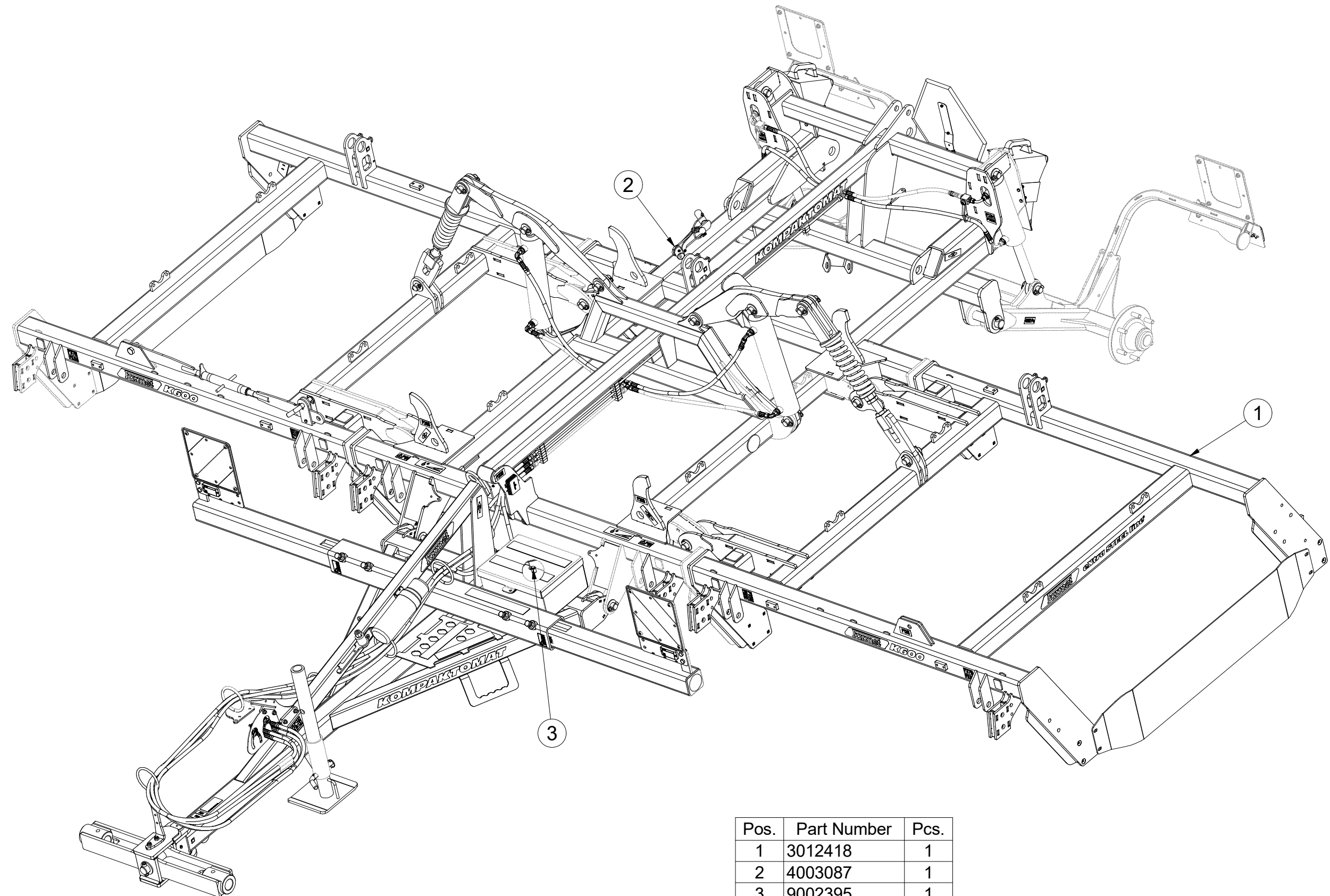

Pos.	Part Number	Pcs.
1	3012418	1
2	4003087	1
3	9002395	1

Ⓒ NASAZOVACÍ KLIKA

Ⓓ MONTAGEGRIF

Ⓕ POIGNÉE DE MONTAGE

4003087

Ⓖ MOUNTING HANDLE

Ⓡ МОНТАЖНАЯ РУЧКА

Ⓢ UCHWYT MONTAŻOWY

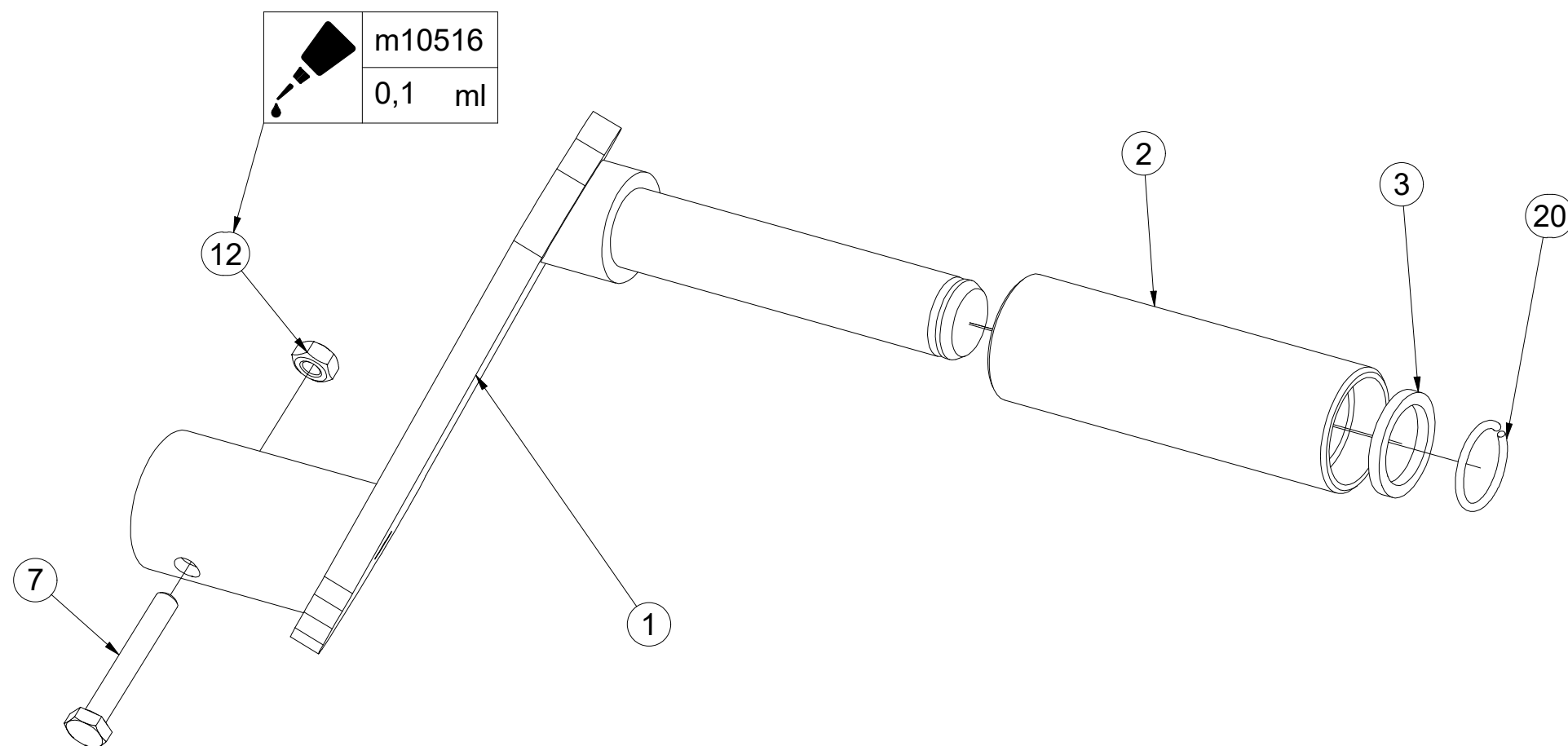
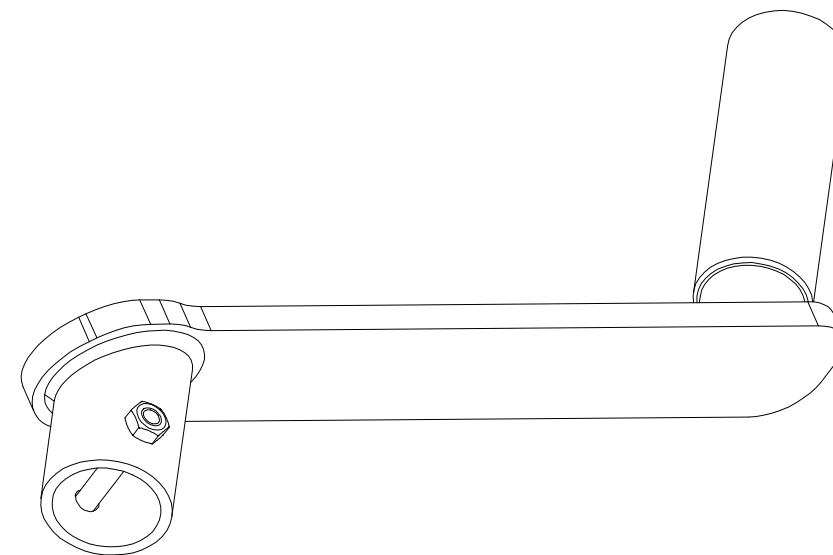

Pos.	Part Number	Pcs.
1	4003092	1
2	4001533	1
3	4004828	1
7	m04641	1
12	m01295	1
20	m06561	1
25	m10516	0,1

Ⓒ POLOTOVAR STROJE

Ⓓ MASCHINEN-HALBFABRIKAT

Ⓕ MACHINE - SEMI-PRODUIT

Ⓖ SEMIFINISHED MACHINE

Ⓡ ПОЛУФАБРИКАТ МАШИНЫ

Ⓟ PÓŁFABRYKAT MASZYN



3012418

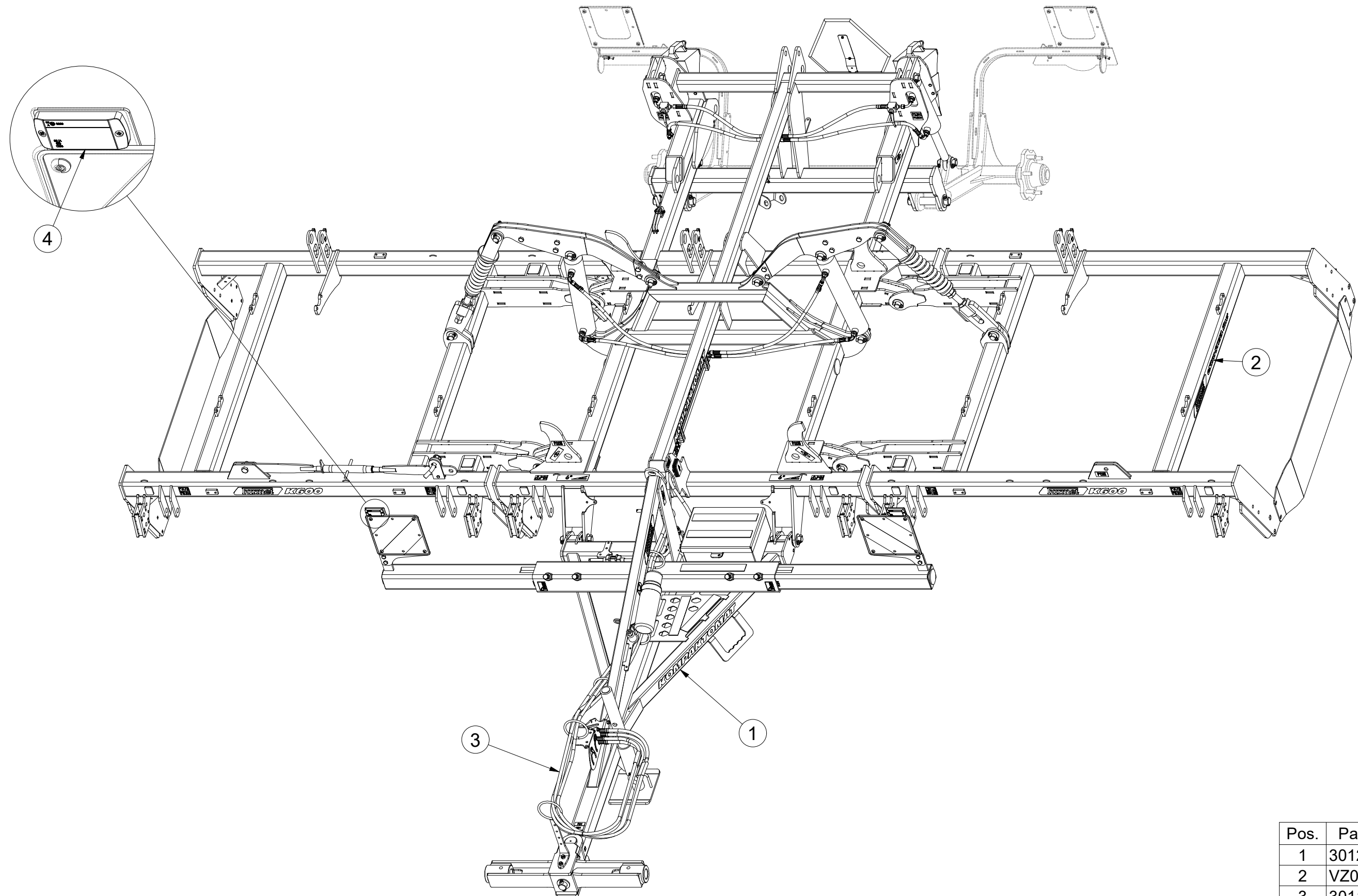

Pos.	Part Number	Pcs.
1	3012414	1
2	VZ00039968	1
3	3011328	1
4	3012429	1

☉ POLOTOVAR STROJE

☉ MASCHINEN-HALBFABRIKAT

☉ MACHINE - SEMI-PRODUIT

☉ SEMIFINISHED MACHINE

☉ ПОЛУФАБРИКАТ МАШИНЫ

☉ PÓLFABRYKAT MASZYNY



3012418

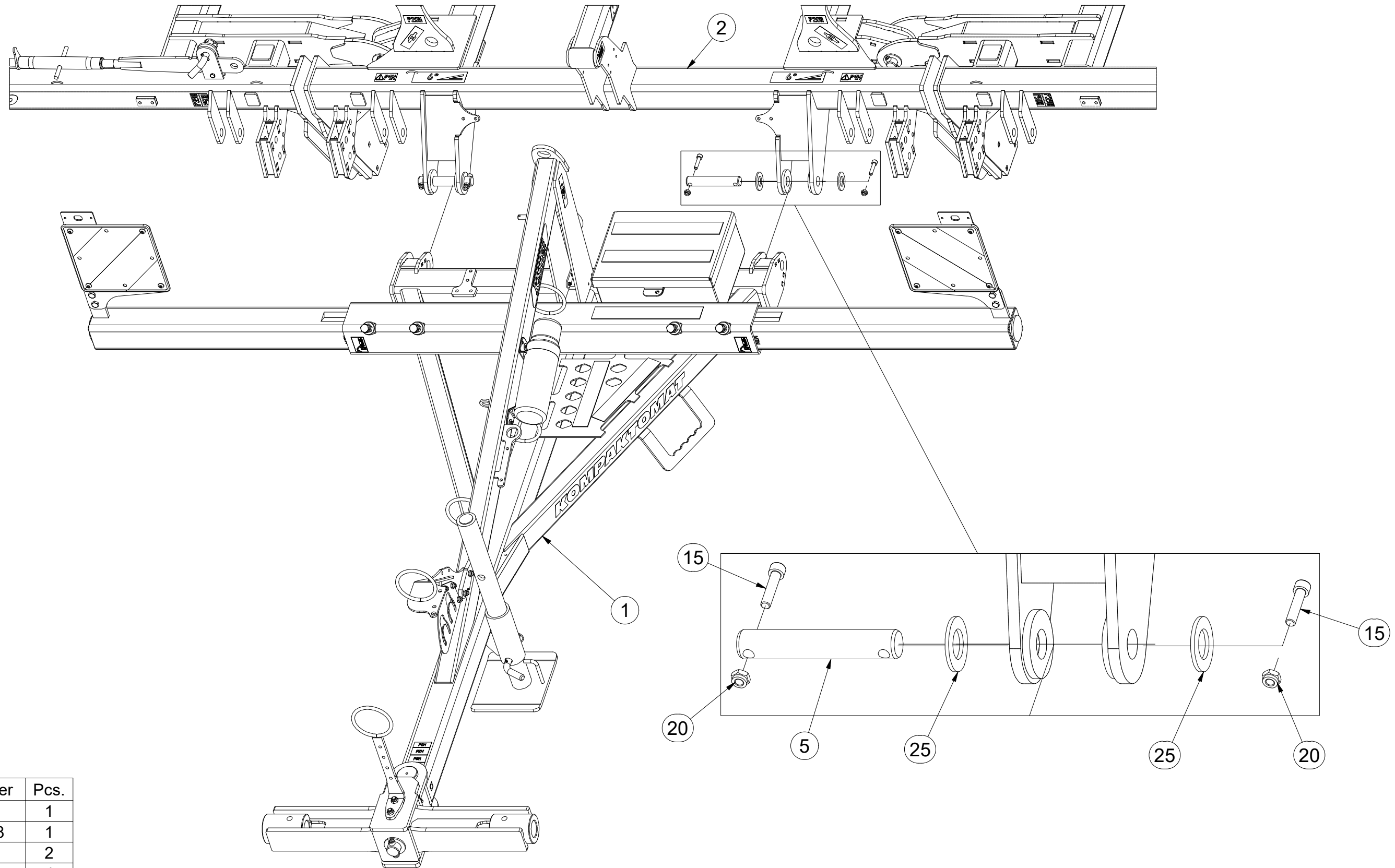

Pos.	Part Number	Pcs.
1	3012414	1
2	VZ00039968	1
5	4011050	2
15	m14143	4
20	m03775	4
25	m14029	4

☉ POLOTOVAR STROJE

☉ MASCHINEN-HALBFABRIKAT

☉ MACHINE - SEMI-PRODUIT

☉ SEMIFINISHED MACHINE

☉ ПОЛУФАБРИКАТ МАШИНЫ

☉ PÓLFABRYKAT MASZYNY



VZ00039968

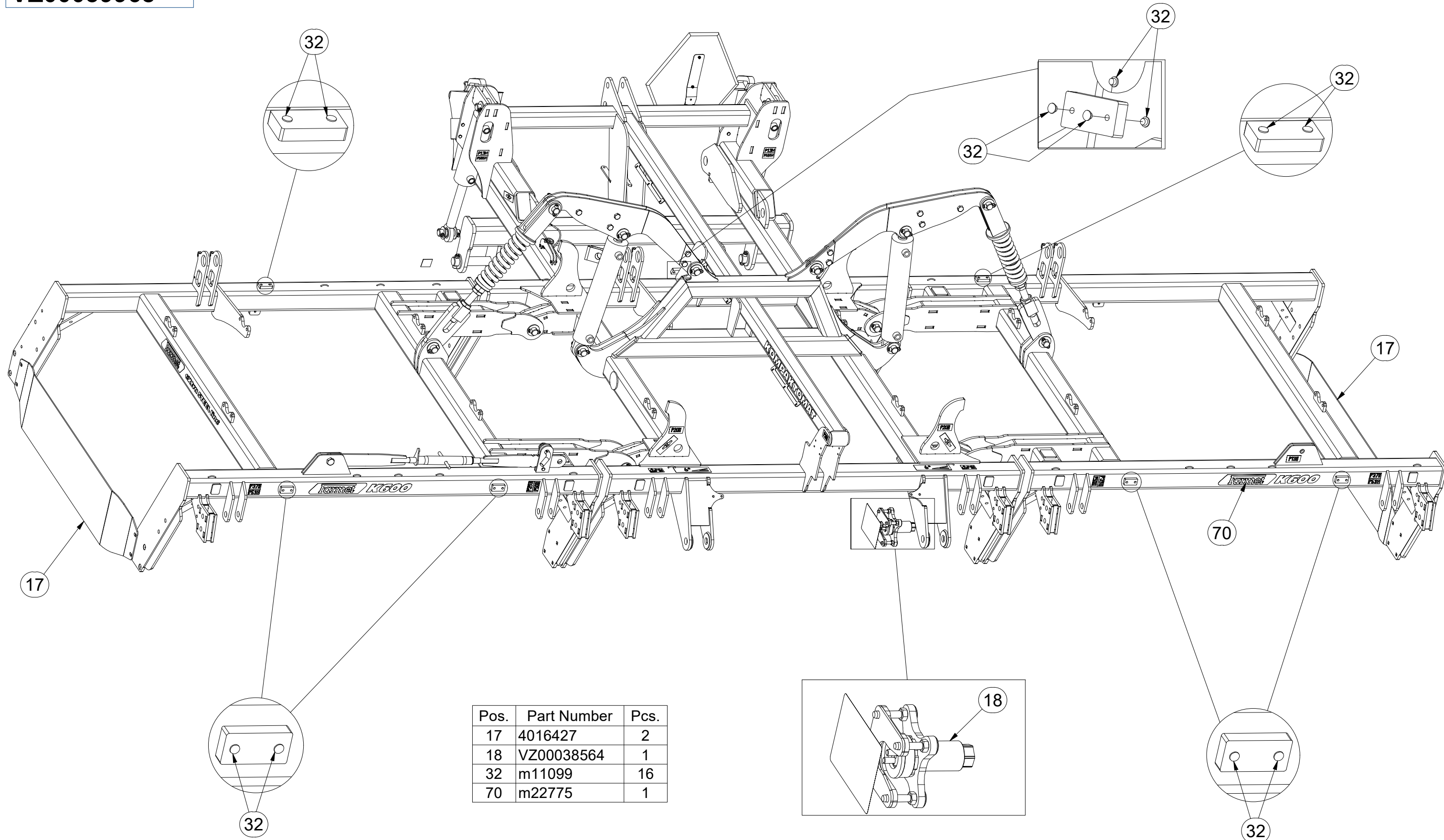

Pos.	Part Number	Pcs.
17	4016427	2
18	VZ00038564	1
32	m11099	16
70	m22775	1

☉ POLOTOVAR STROJE

☉ MASCHINEN-HALBFABRIKAT

☉ MACHINE - SEMI-PRODUIT

☉ SEMIFINISHED MACHINE

☉ ПОЛУФАБРИКАТ МАШИНЫ

☉ PÓLFABRYKAT MASZYNY



VZ00039968

Pos.	Part Number	Pcs.	Pos.	Part Number	Pcs.
1	VZ00039066	1	30	m02579	2
2	VZ00039096	1	42	m01096	1
6	4005363	2	43	m14143	36
7	4021664	2	45	m04241	1
10	4003966	1	51	m04503	9
12	4014569	2	52	m03775	36
13	4007584	2	54	m05648	1
15	4007641	4	55	m04043	2
24	4012011	1	61	m14029	36
25	m10454	2			

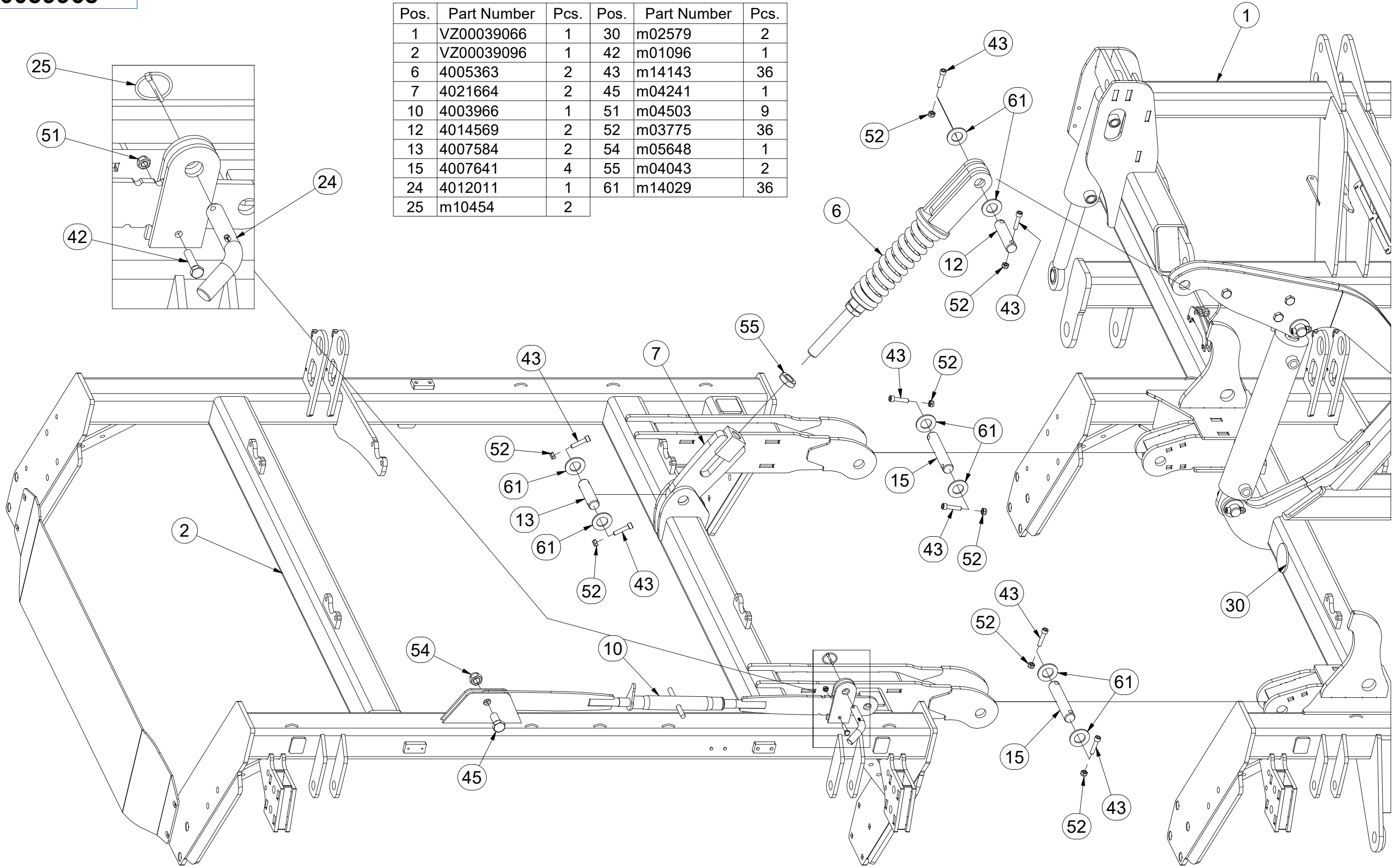

Ⓒ POLOTOVAR STROJE

Ⓓ MASCHINEN-HALBFABRIKAT

Ⓕ MACHINE - SEMI-PRODUIT

Ⓖ SEMIFINISHED MACHINE

Ⓡ ПОЛУФАБРИКАТ МАШИНЫ

Ⓟ PÓŁFABRYKAT MASZYN



VZ00039968

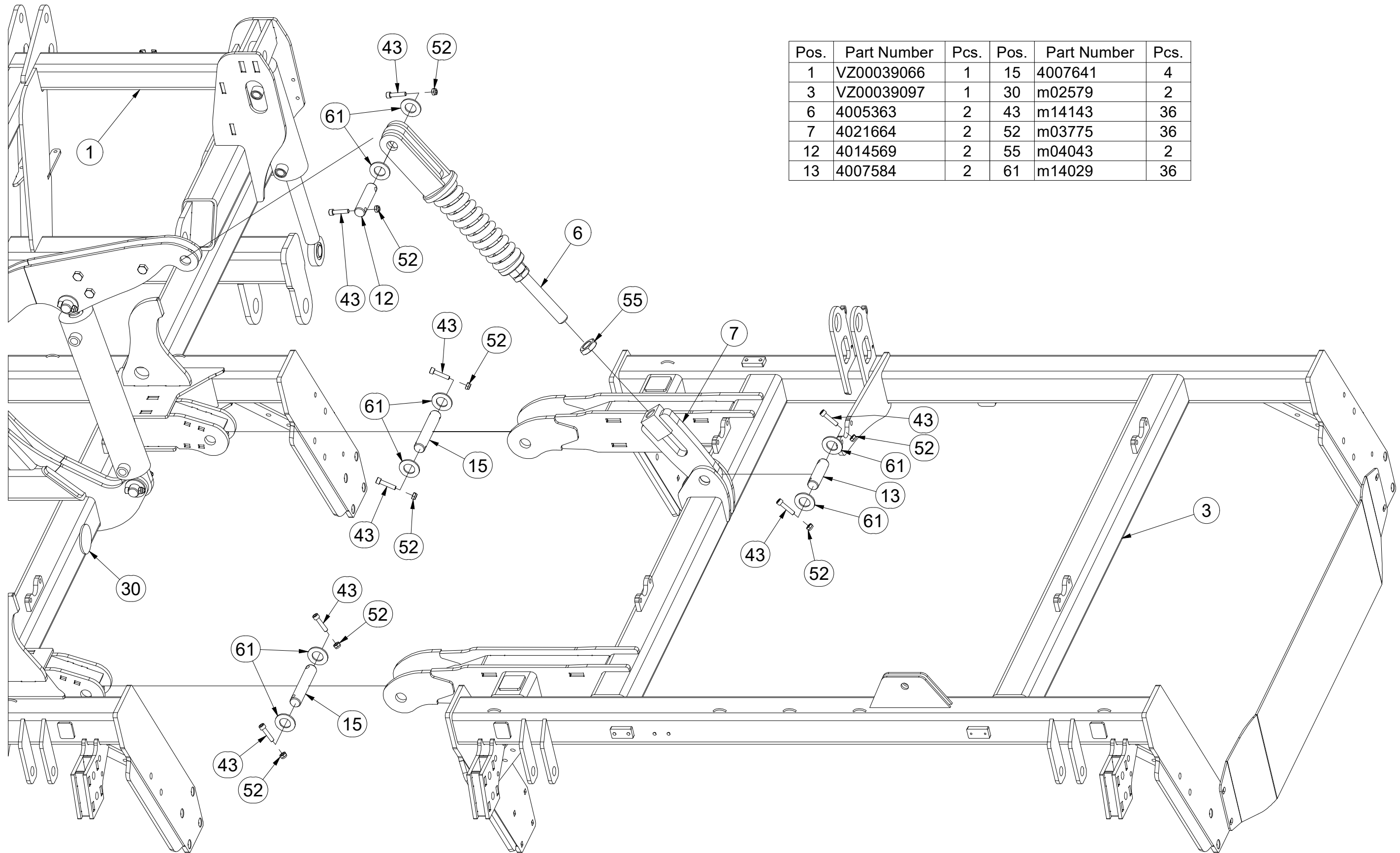

Pos.	Part Number	Pcs.	Pos.	Part Number	Pcs.
1	VZ00039066	1	15	4007641	4
3	VZ00039097	1	30	m02579	2
6	4005363	2	43	m14143	36
7	4021664	2	52	m03775	36
12	4014569	2	55	m04043	2
13	4007584	2	61	m14029	36

☉ POLOTOVAR STROJE

☉ MASCHINEN-HALBFABRIKAT

☉ MACHINE - SEMI-PRODUIT

☉ SEMIFINISHED MACHINE

☉ ПОЛУФАБРИКАТ МАШИНЫ

☉ PÓLFABRYKAT MASZYNY



VZ00039968

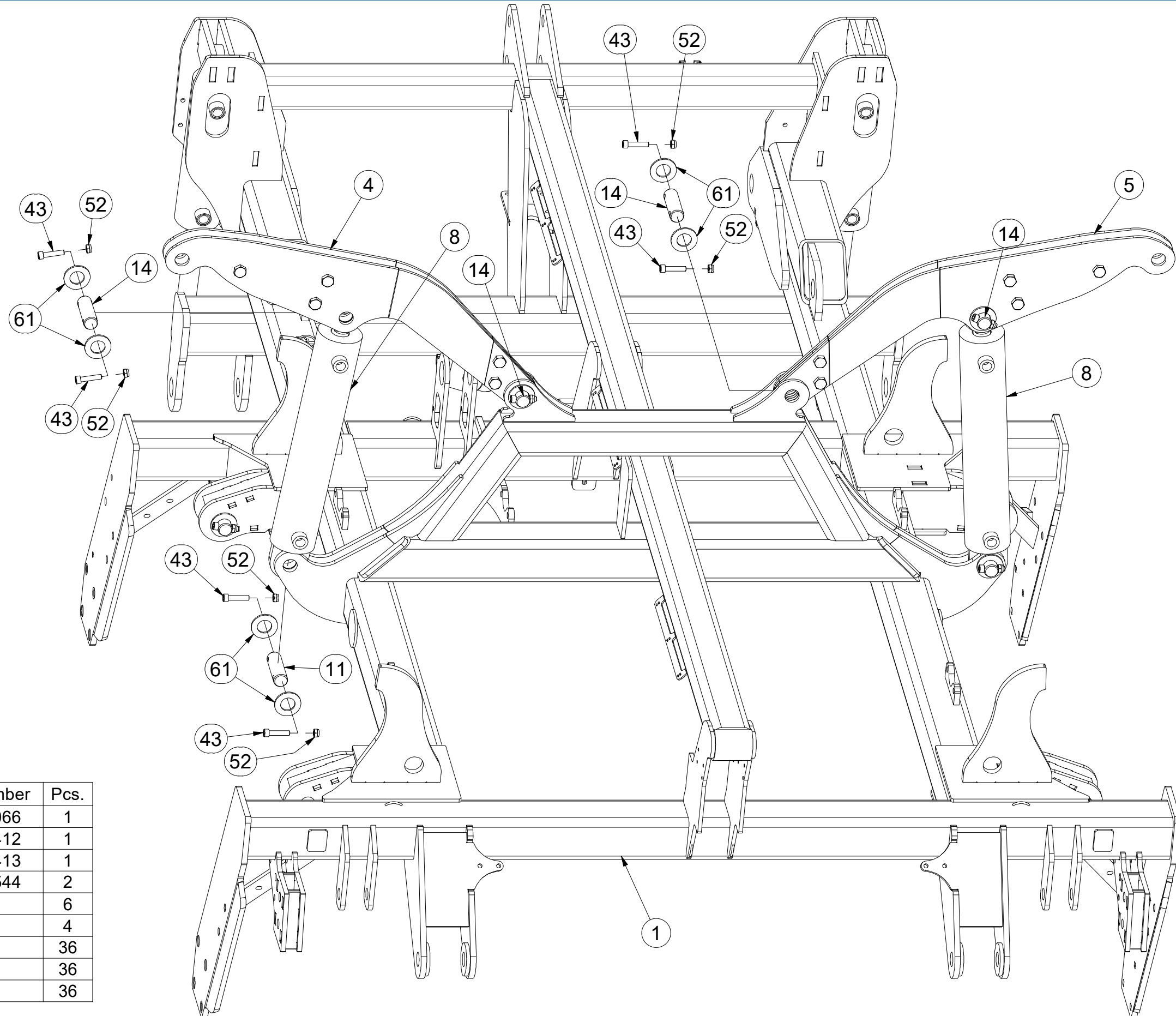

Pos.	Part Number	Pcs.
1	VZ00039066	1
4	VZ00040412	1
5	VZ00040413	1
8	VZ00004544	2
11	4008234	6
14	4007640	4
43	m14143	36
52	m03775	36
61	m14029	36

Ⓒ POLOTOVAR STROJE

Ⓓ MASCHINEN-HALBFABRIKAT

Ⓕ MACHINE - SEMI-PRODUIT

Ⓖ SEMIFINISHED MACHINE

Ⓡ ПОЛУФАБРИКАТ МАШИНЫ

Ⓢ PÓŁFABRYKAT MASZYNY



VZ00039968

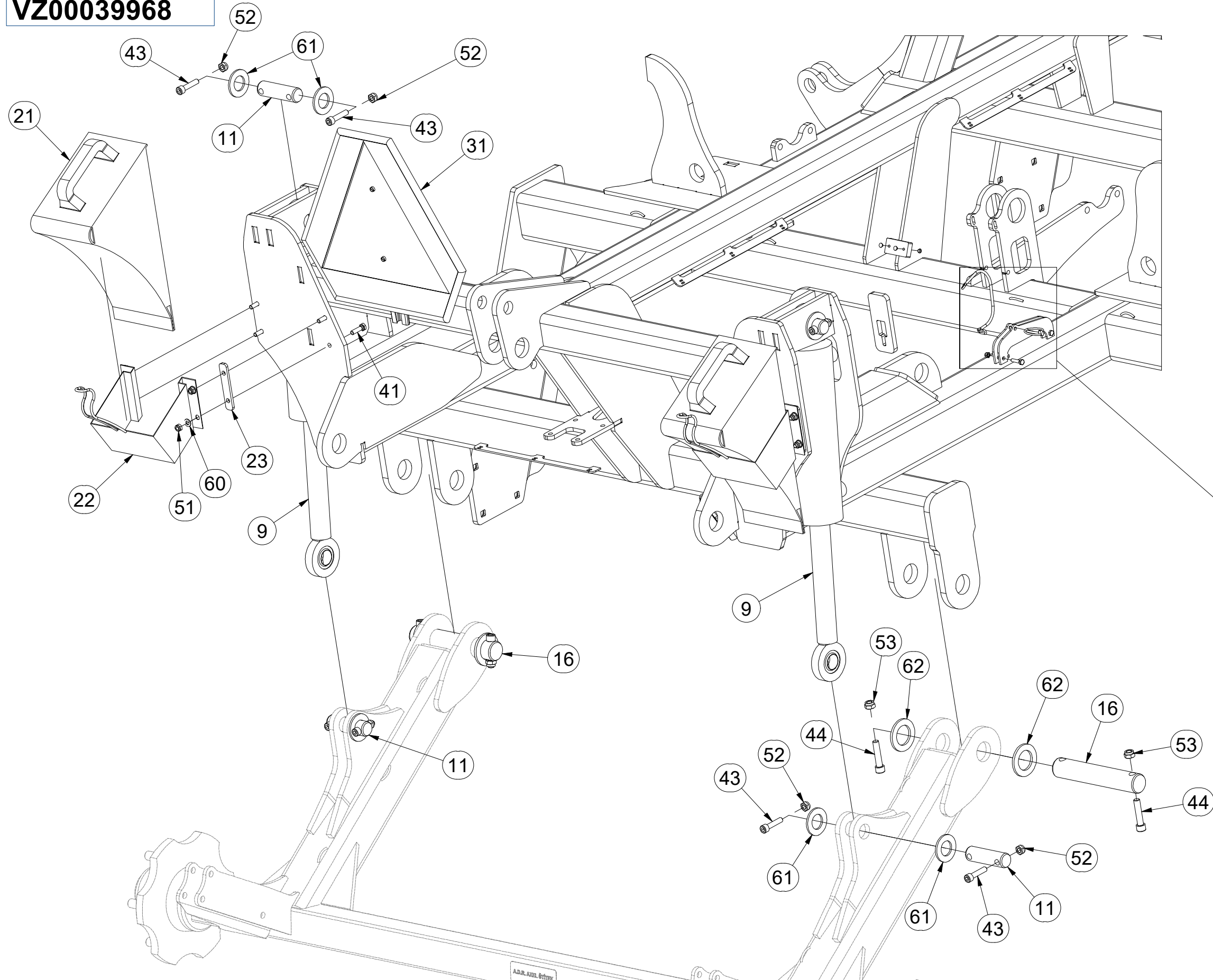

Pos.	Part Number	Pcs.
9	VZ00004549	2
11	4008234	6
25	m10454	2
21	m16186	2
22	m12572	2
23	4012712	4
16	4010875	2
31	m05371	1
33	m12467	1
40	m01075	2
41	m04791	8
43	m14143	36
44	m14008	4
50	m05560	2
51	m04503	9
52	m03775	36
53	m04301	4
60	m01203	8
61	m14029	36
62	4013139	4

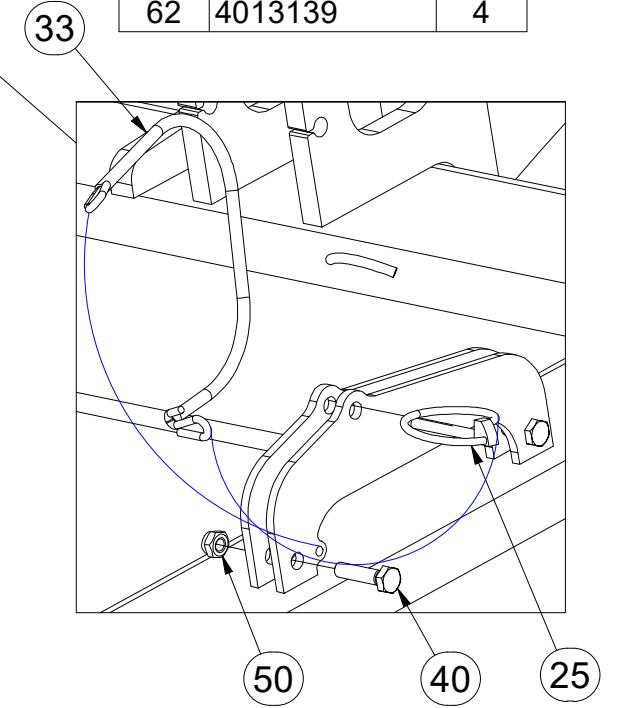

ⒸZ SAMOLEPKY STROJE

Ⓓ AUFKLEBER MASCHINEN

Ⓕ VOITURE MACHINES

ⒸB STICKERS MACHINES

ⒸU СТИКЕРЫ МАШИНЫ

ⒸL NAKLEJKI MASZYNY



m22775

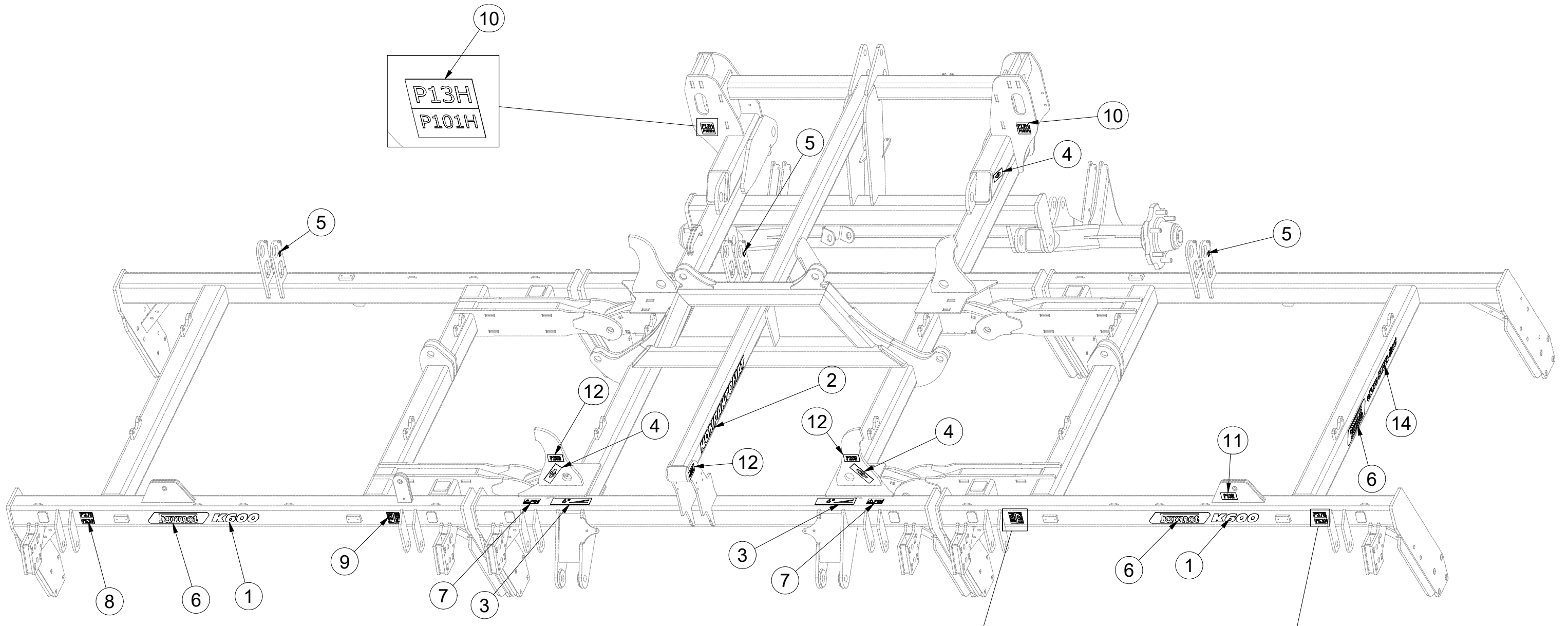

Pos.	Part Number	Pcs.	Pos.	Part Number	Pcs.
1	m07693	4	7	m04359	3
2	m07688	2	8	m11297	4
3	m03314	2	9	m11296	4
4	m03316	4	10	m11299	2
5	m03320	3	11	m04363	1
6	m13116	6	12	m04368	6
			14	m10353	2

- Ⓒ SAMOLEPKY STROJE
- Ⓓ AUFKLEBER MASCHINEN
- Ⓕ VOITURE MACHINES

- Ⓖ STICKERS MACHINES
- Ⓡ СТИКЕРЫ МАШИНЫ
- Ⓟ NAKLEJKI MASZYNY



m22775

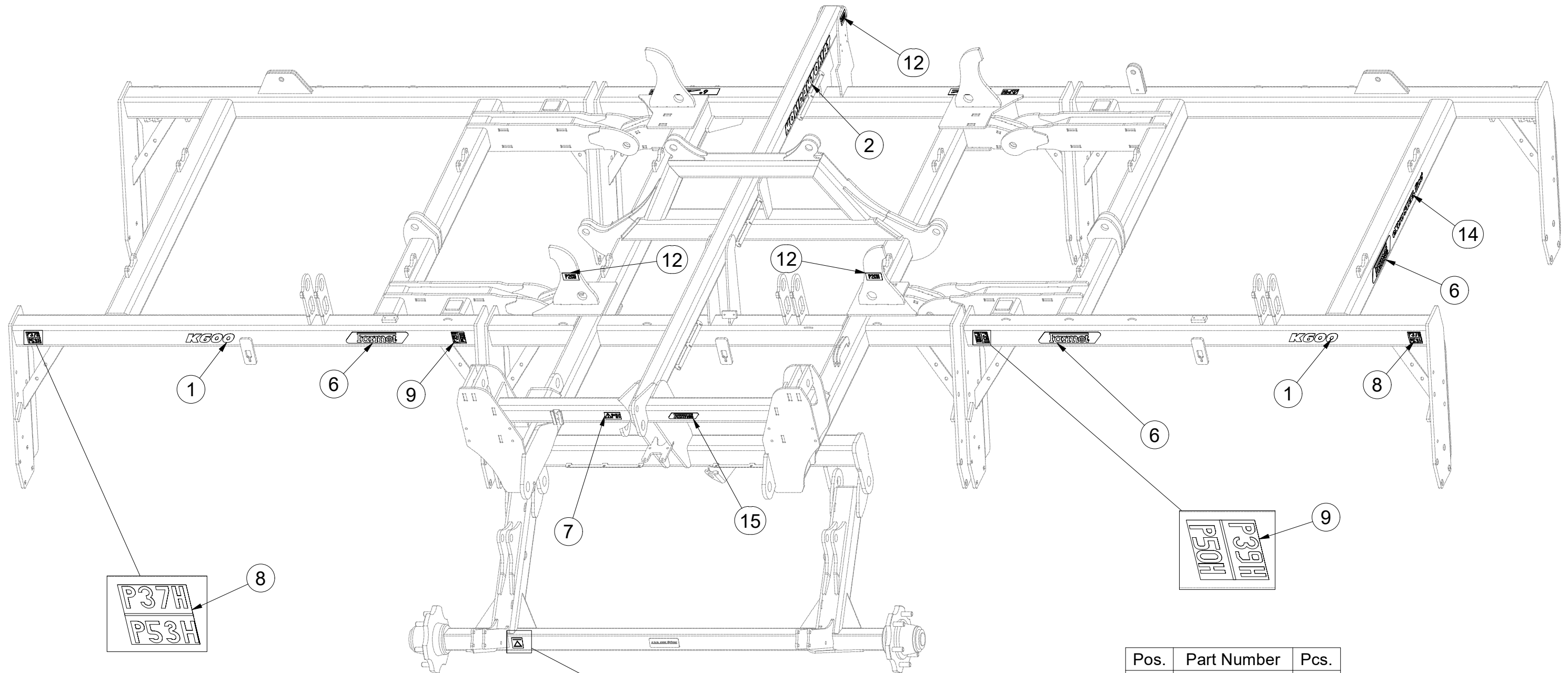

Pos.	Part Number	Pcs.
1	m07693	4
2	m07688	2
6	m13116	6
7	m04359	3
8	m11297	4
9	m11296	4
12	m04368	6
14	m10353	2
15	m13401	1
17	m03512	2

- Ⓒ RÁM
- Ⓓ RAHMEN
- Ⓕ CHASSIS

- Ⓖ FRAME
- Ⓡ PAMA
- Ⓟ RAMA



VZ00040412

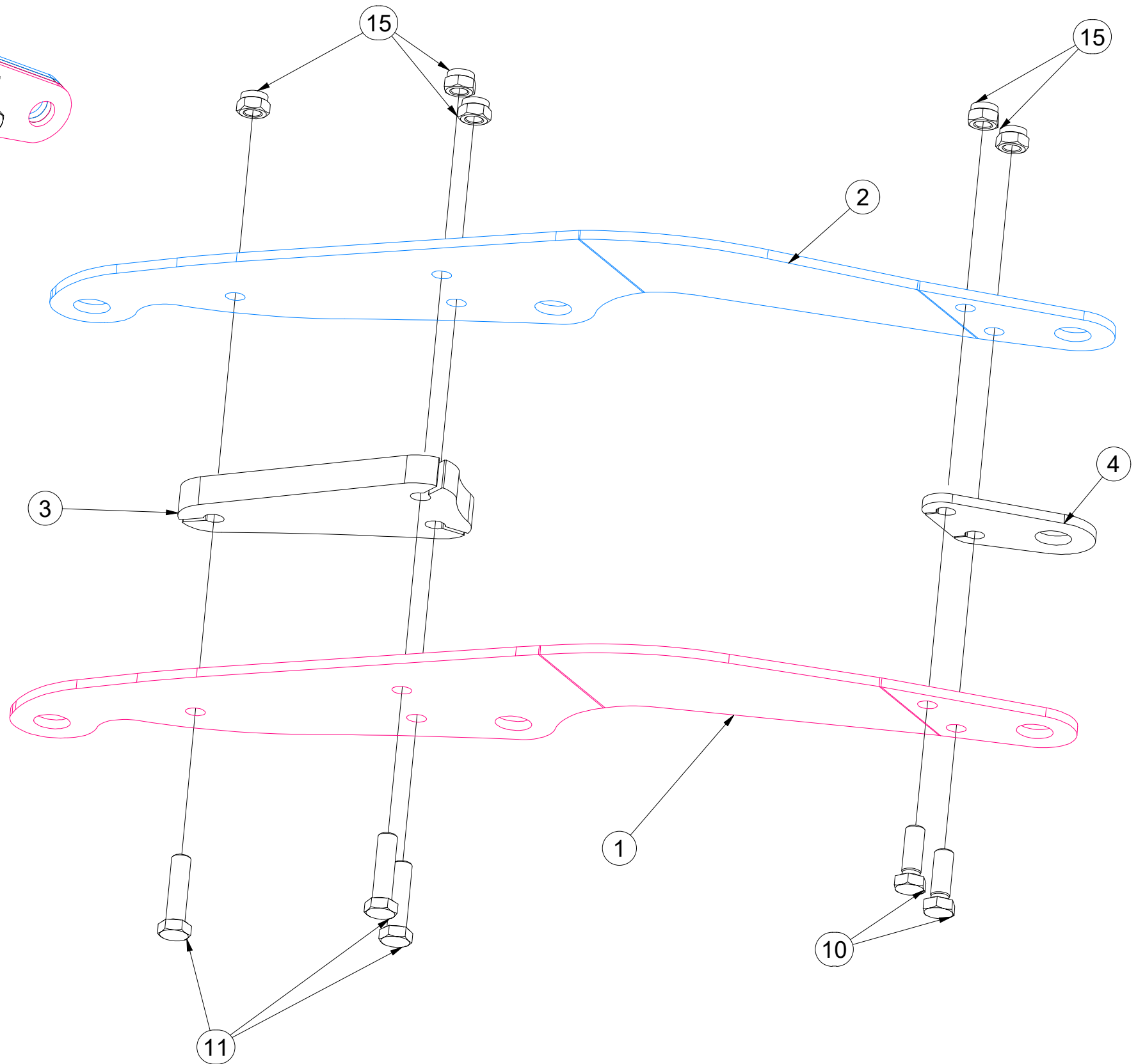
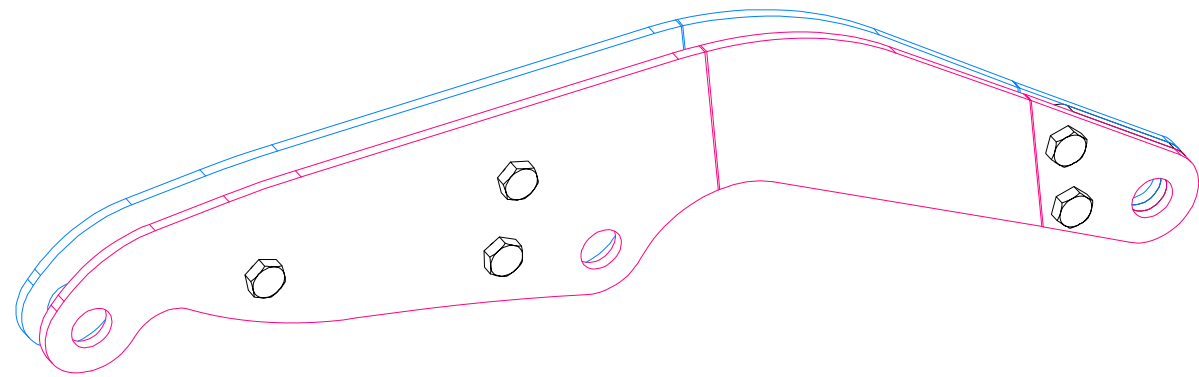

Pos.	Part Number	Pcs.
1	VZ00040414	1
2	VZ00040415	1
3	VZ00004778	1
4	VZ00002684	1
10	m02254	2
11	m00619	3
15	m03683	5

(CZ) RÁM
 (D) RAHMEN
 (F) CHASSIS

(GB) FRAME
 (RU) ПАМА
 (PL) RAMA



VZ00040413

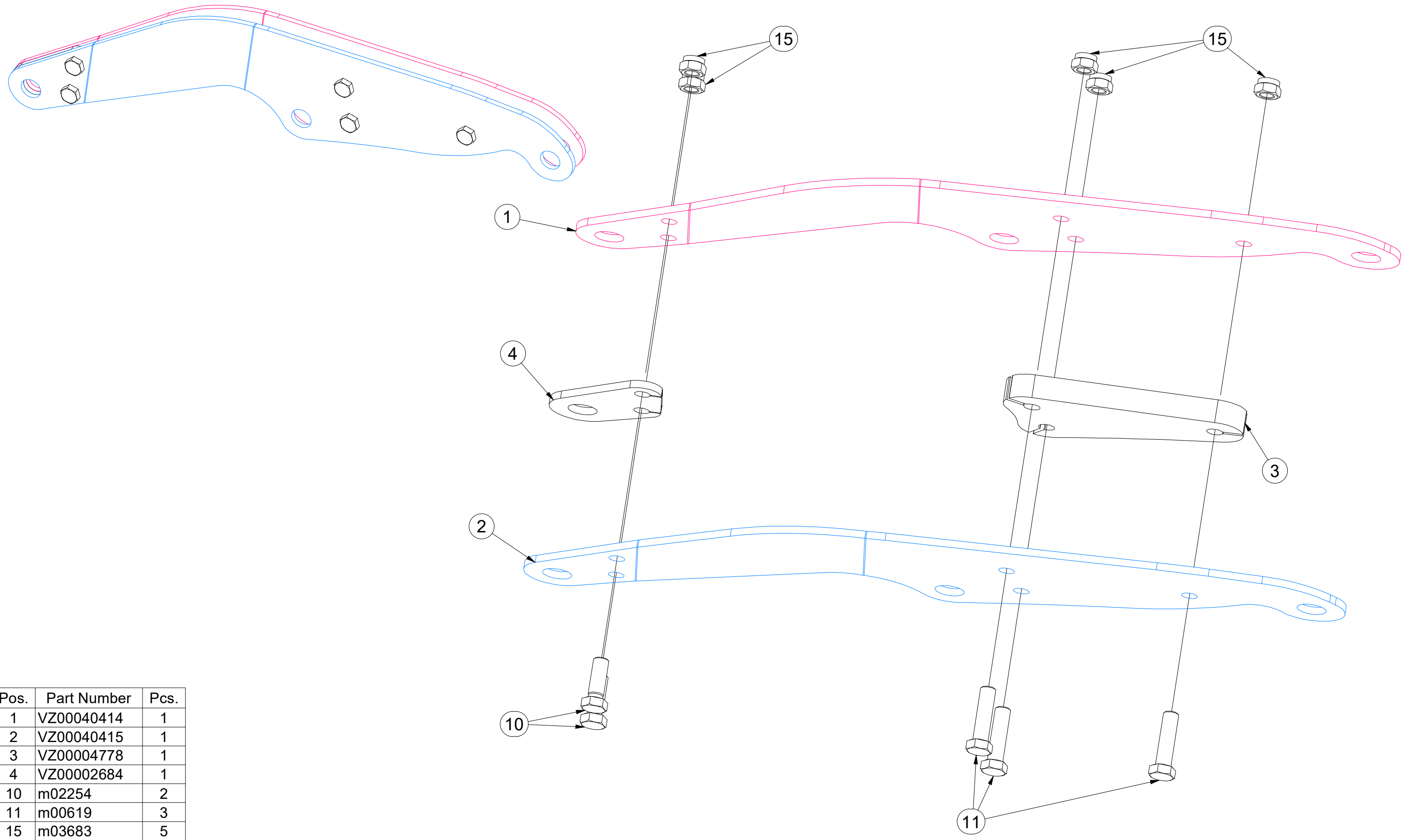

Pos.	Part Number	Pcs.
1	VZ00040414	1
2	VZ00040415	1
3	VZ00004778	1
4	VZ00002684	1
10	m02254	2
11	m00619	3
15	m03683	5

Ⓒ SPOJOVACÍ TÁHLO
Ⓓ VERBINDUNGSSTANGE
Ⓕ TIGE DE RACCORDEMENT

Ⓖ CONNECTING ROD
Ⓡ СОЕДИНИТЕЛЬНАЯ ТЯГА
Ⓟ KORBOWÓD



4003966

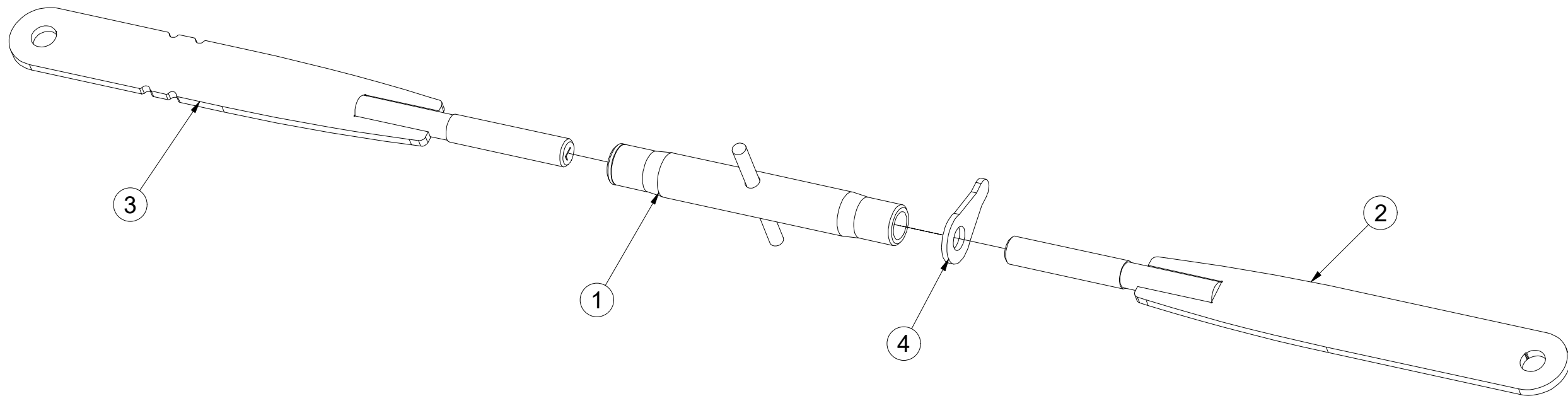
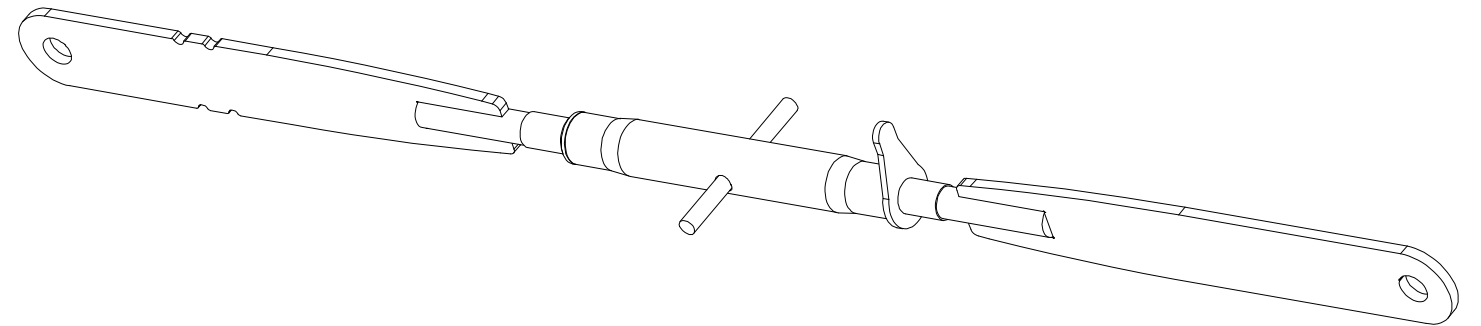

Pos.	Part Number	Pcs.
1	m08880	1
2	4023421	1
3	4023423	1
4	m08881	1

Ⓒ TÁHLO SKLÁPĚNÍ

Ⓓ ZUGSTANGE ZUR KIPPUNG

Ⓕ TIGES DE L'ESSIEU

4005363

Ⓖ TILTING PULL ROD

Ⓡ ТЯГИ ТРАНСПОРТНОЙ ОСИ

Ⓟ SPRZĘGI OSI

Farmet

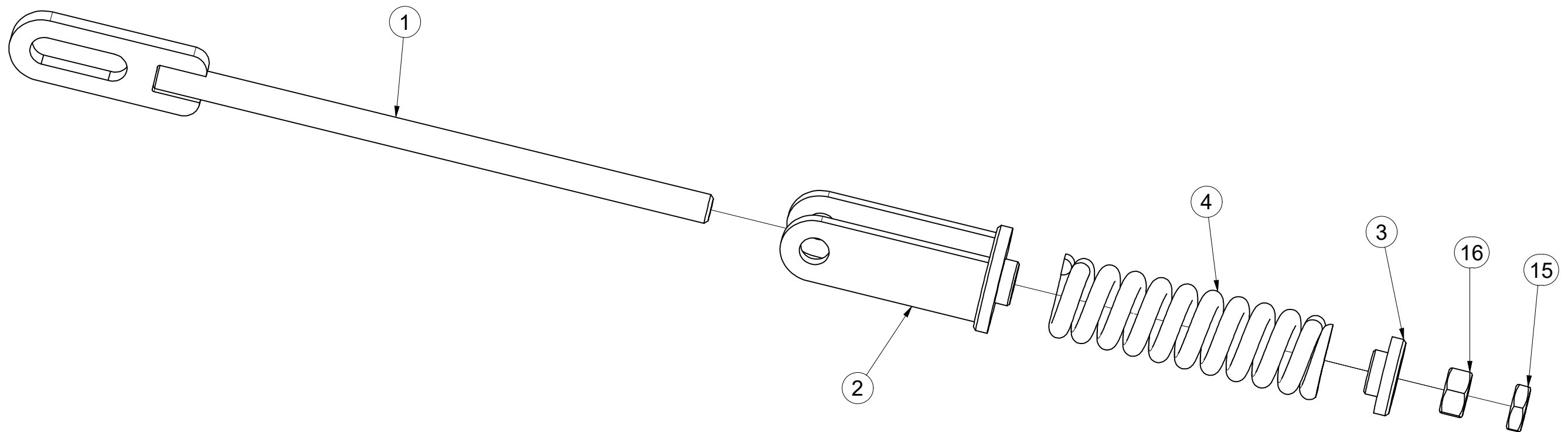
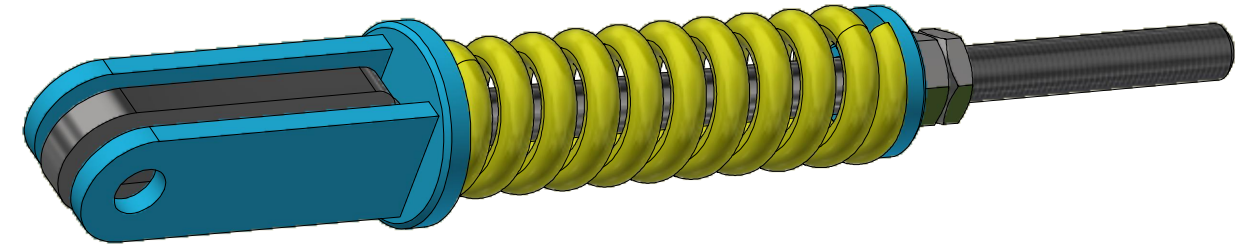

Pos.	Part Number	Pcs.
1	4005358	1
2	4005361	1
3	4000023	1
4	m06482	1
15	m04043	1
16	m01309	1

ⒸZ HYDRAULIKA STROJE

Ⓓ HYDRAULIK DER MASCHINE

Ⓕ HYDRAULIQUE DE LA MACHINE

ⒼB MACHINE HYDRAULICS

Ⓔ RU ГИДРАВЛИКА МАШИНЫ

Ⓗ PL HYDRAULIKA MASZYN



3011328

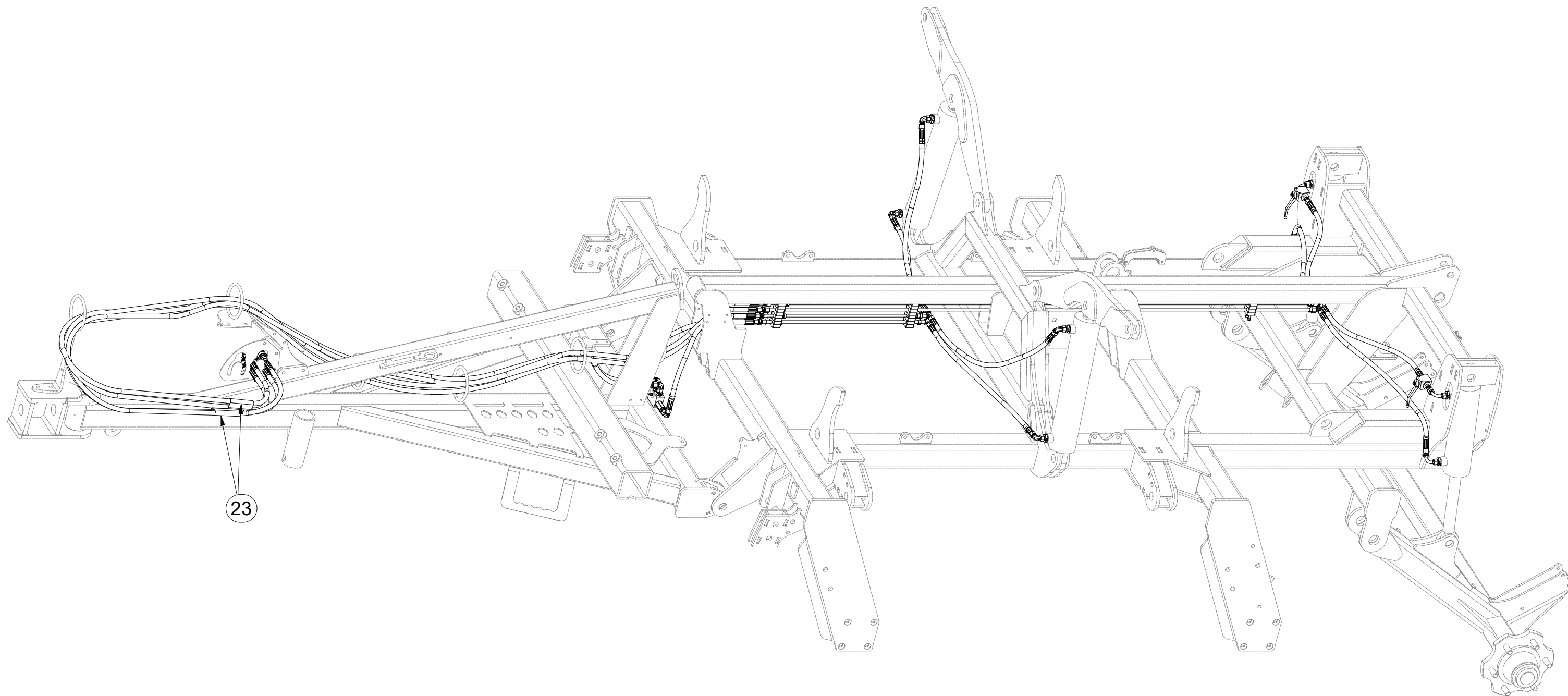

Pos.	Part Number	Pcs.
23	m11183	2

ⒸZ HYDRAULIKA STROJE

Ⓓ HYDRAULIK DER MASCHINE

Ⓕ HYDRAULIQUE DE LA MACHINE

ⒼB MACHINE HYDRAULICS

Ⓔ RU ГИДРАВЛИКА МАШИНЫ

Ⓗ PL HYDRAULIKA MASZYN



3011328

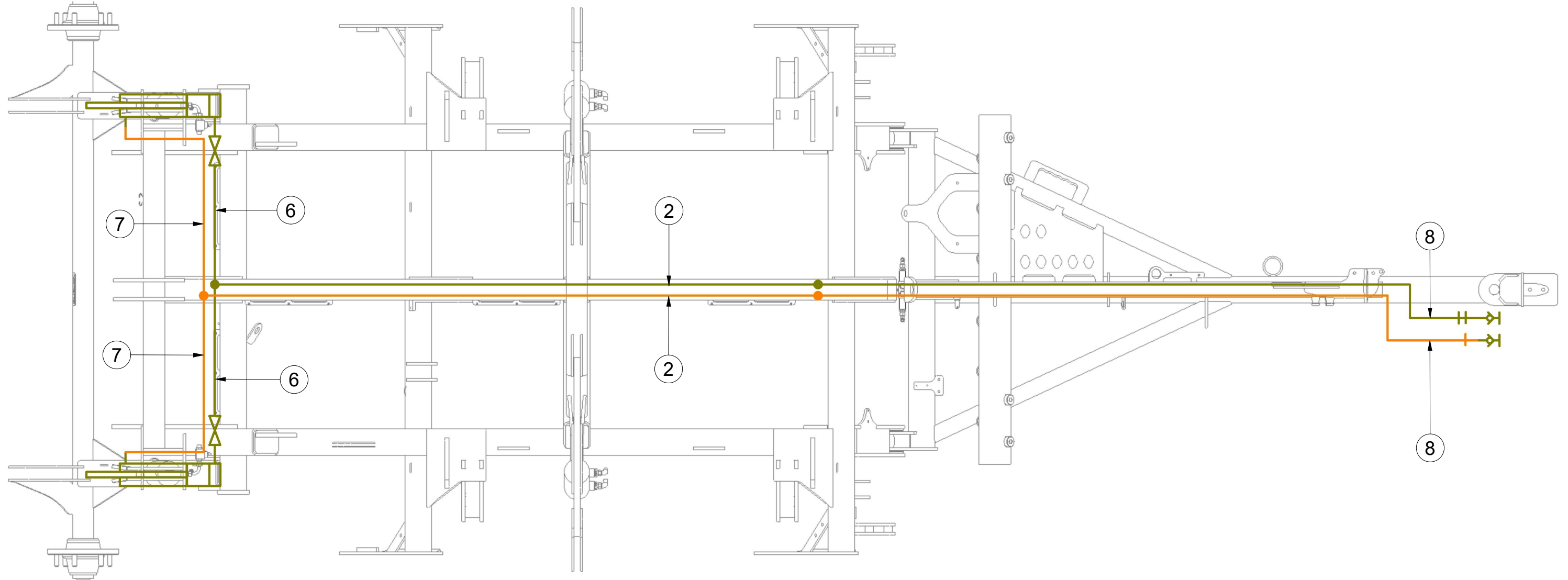

Pos.	Part Number	Pcs.
2	m04803	2
6	m03713	4
7	m04033	2
8	m09431	2

ⒸZ HYDRAULIKA STROJE

ⒸD HYDRAULIK DER MASCHINE

ⒸF HYDRAULIQUE DE LA MACHINE

ⒸGB MACHINE HYDRAULICS

ⒸRU ГИДРАВЛИКА МАШИНЫ

ⒸPL HYDRAULIKA MASZYN



3011328

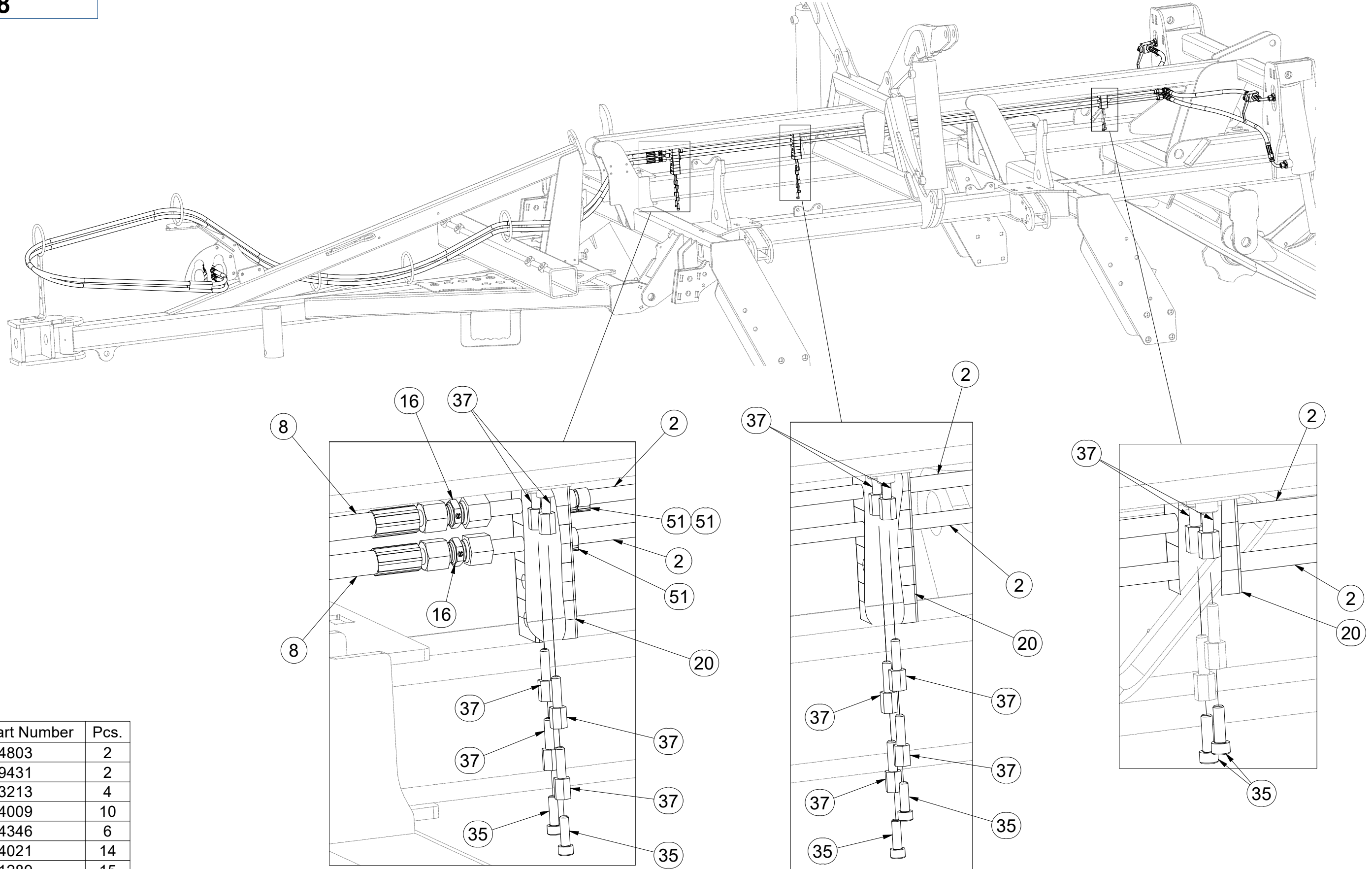

Pos.	Part Number	Pcs.
2	m04803	2
8	m09431	2
16	m03213	4
20	m04009	10
35	m04346	6
37	m04021	14
51	m11289	15

ⒸZ HYDRAULIKA STROJE

Ⓓ HYDRAULIK DER MASCHINE

Ⓕ HYDRAULIQUE DE LA MACHINE

ⒼB MACHINE HYDRAULICS

Ⓔ RU ГИДРАВЛИКА МАШИНЫ

Ⓗ PL HYDRAULIKA MASZYNY



3011328

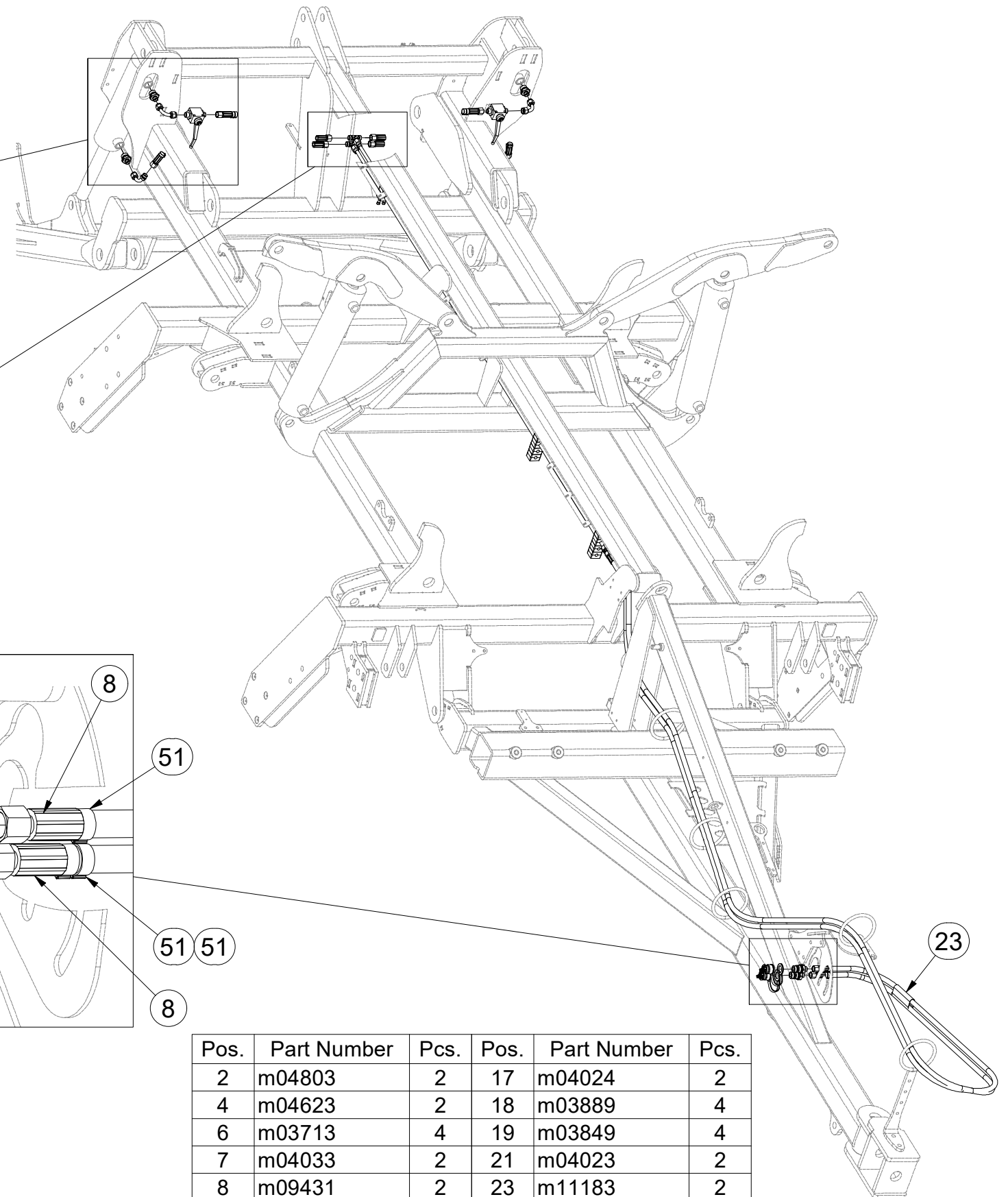
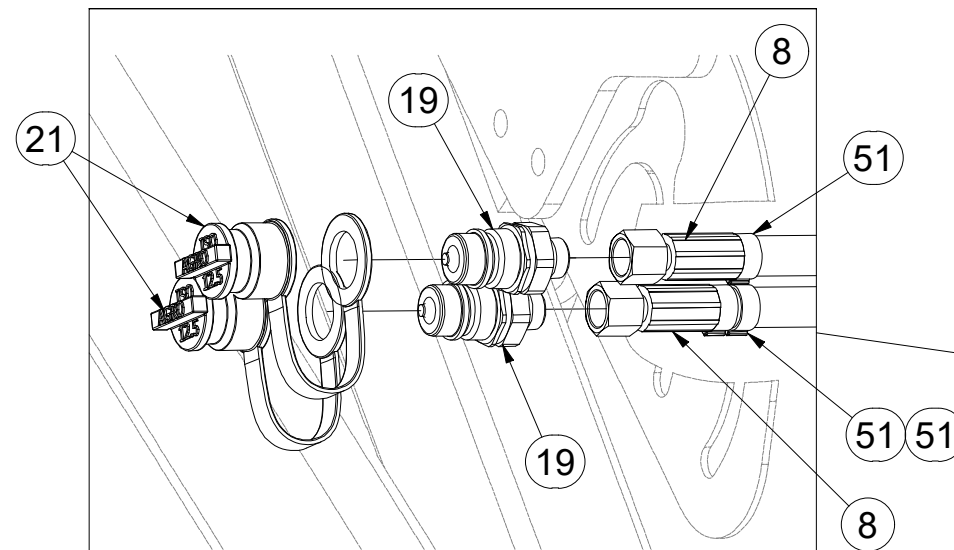
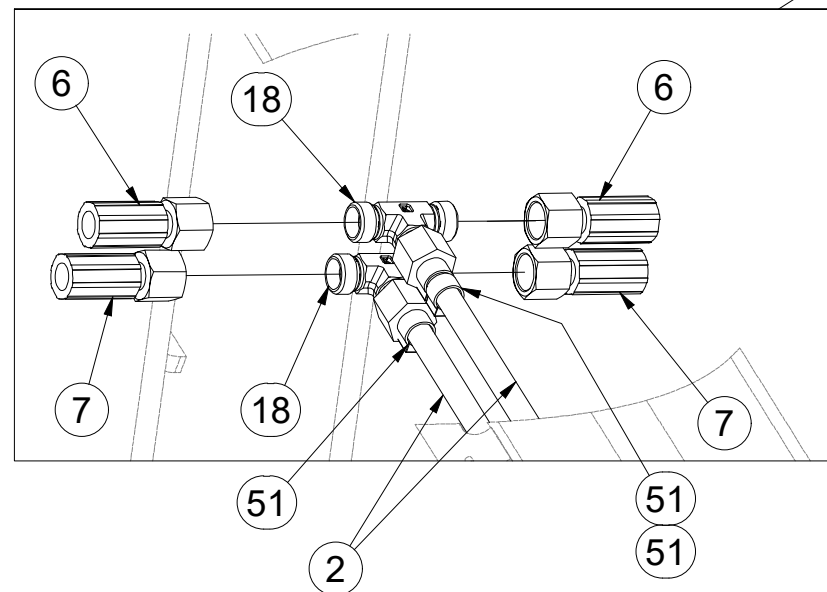
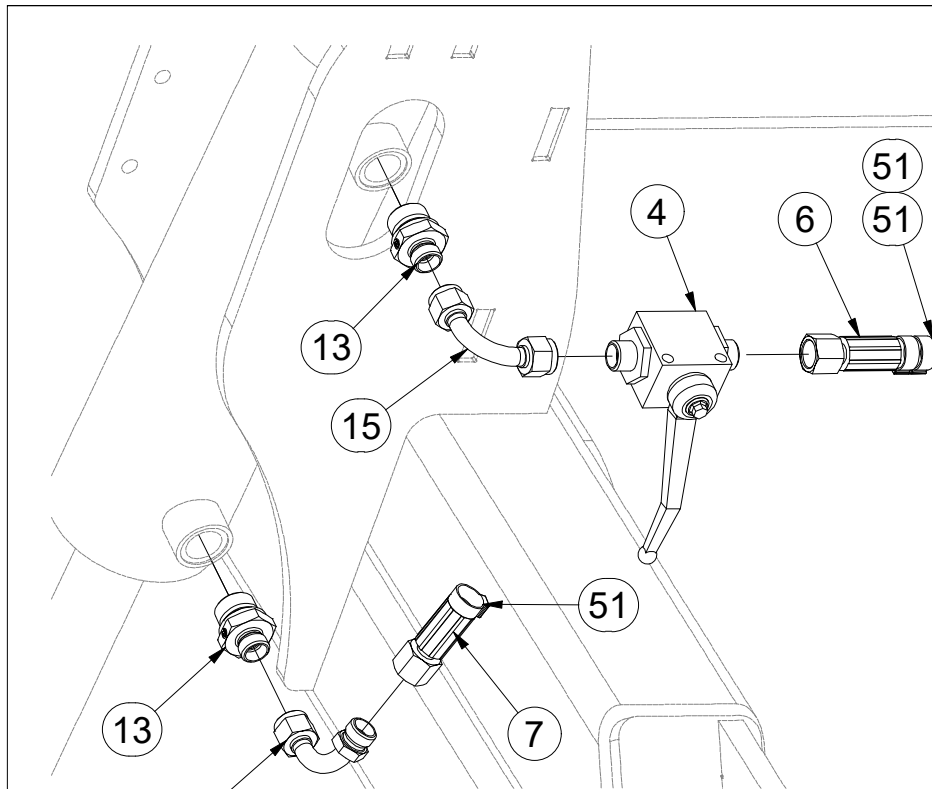

Pos.	Part Number	Pcs.	Pos.	Part Number	Pcs.
2	m04803	2	17	m04024	2
4	m04623	2	18	m03889	4
6	m03713	4	19	m03849	4
7	m04033	2	21	m04023	2
8	m09431	2	23	m11183	2
13	m09934	8	51	m11289	15
15	m04621	2			

Ⓒ HYDRAULIKA STROJE

Ⓓ HYDRAULIK DER MASCHINE

Ⓕ HYDRAULIQUE DE LA MACHINE

Ⓖ MACHINE HYDRAULICS

Ⓡ ГИДРАВЛИКА МАШИНЫ

Ⓟ HYDRAULIKA MASZYN



3011328

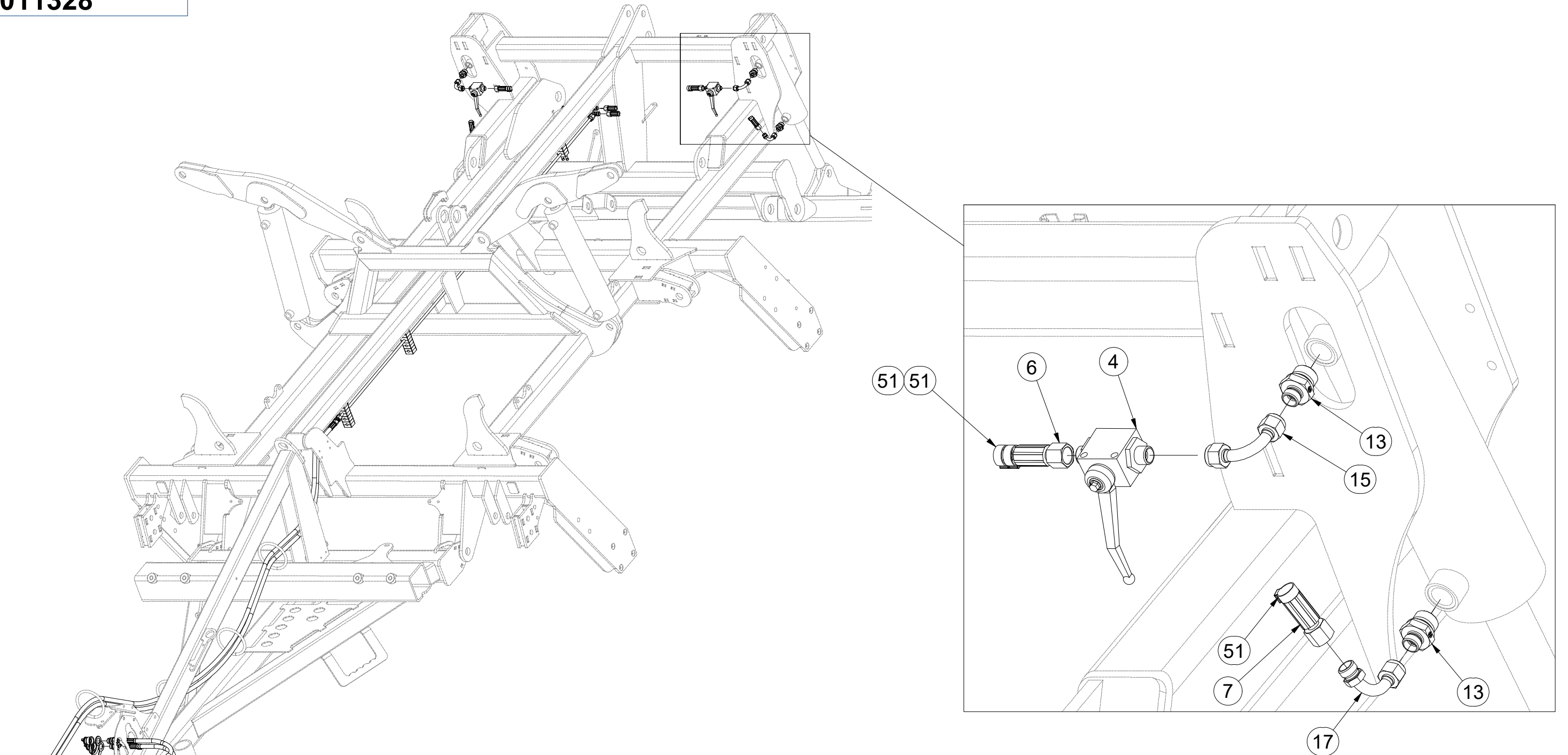

Pos.	Part Number	Pcs.
4	m04623	2
6	m03713	4
7	m04033	2
13	m09934	8
15	m04621	2
17	m04024	2
51	m11289	15

3011328

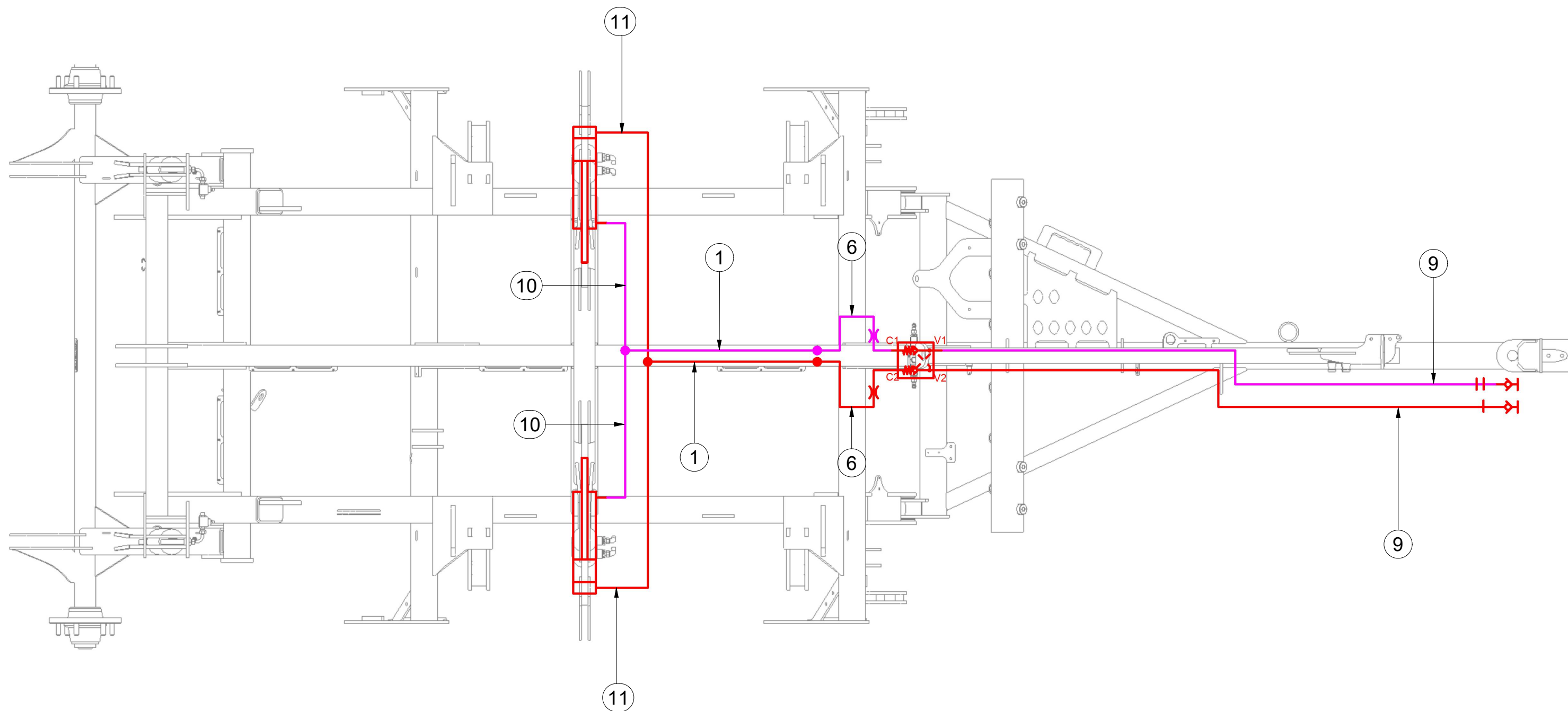

Pos.	Part Number	Pcs.
1	m03975	2
6	m03713	4
9	m04087	2
10	m07646	2
11	m07909	2

3011328

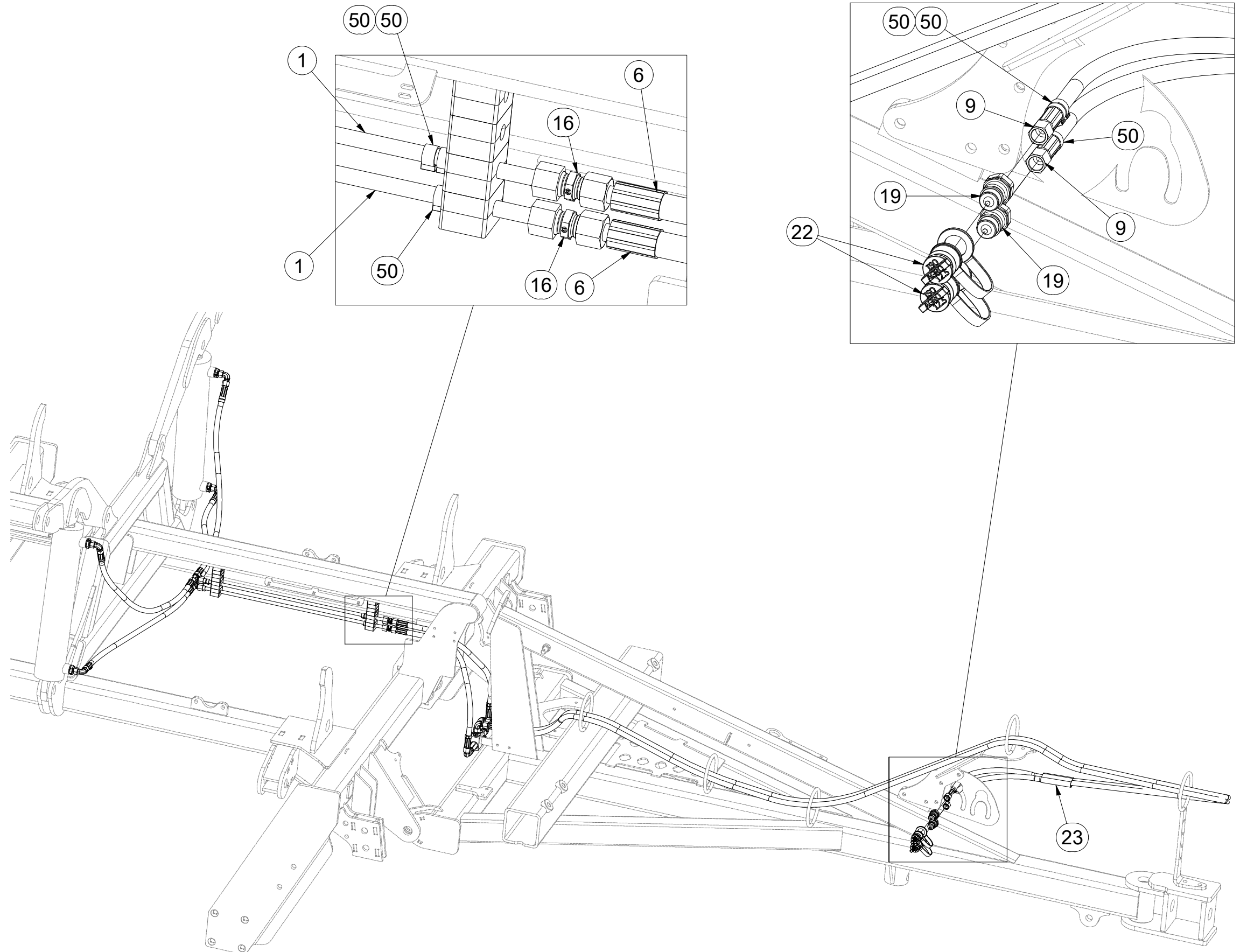

Pos.	Part Number	Pcs.
1	m03975	2
6	m03713	4
9	m04087	2
16	m03213	4
19	m03849	4
22	m04022	2
23	m11183	2
50	m11294	21

ⒸZ HYDRAULIKA STROJE

Ⓓ HYDRAULIK DER MASCHINE

Ⓕ HYDRAULIQUE DE LA MACHINE

ⒸB MACHINE HYDRAULICS

ⒸR ГИДРАВЛИКА МАШИНЫ

ⒸL HYDRAULIKA MASZYNY



3011328

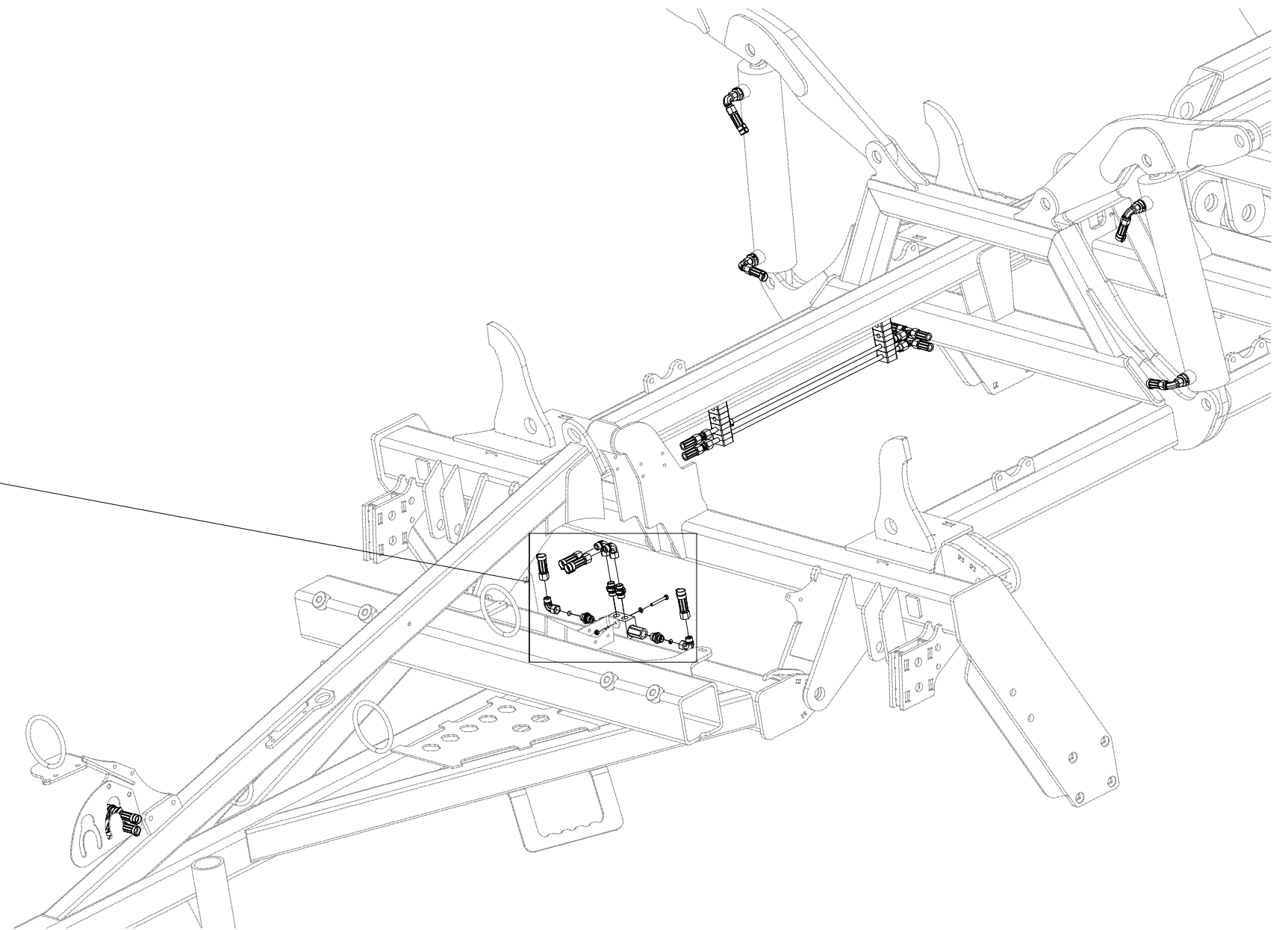
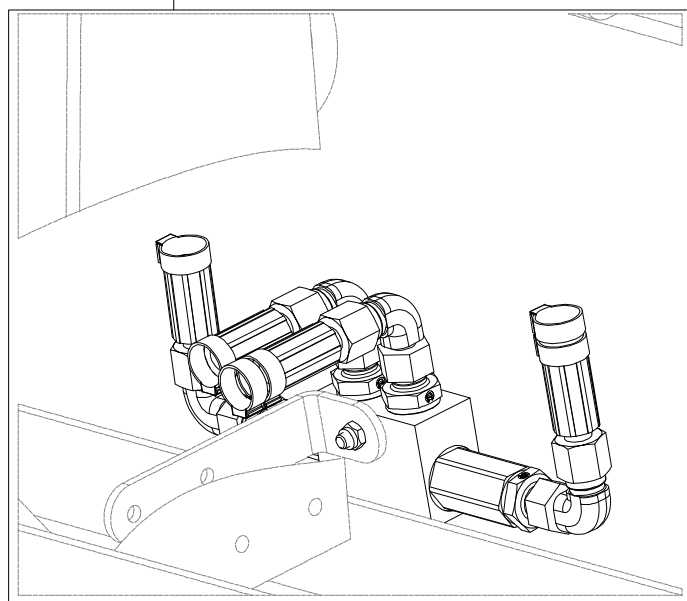
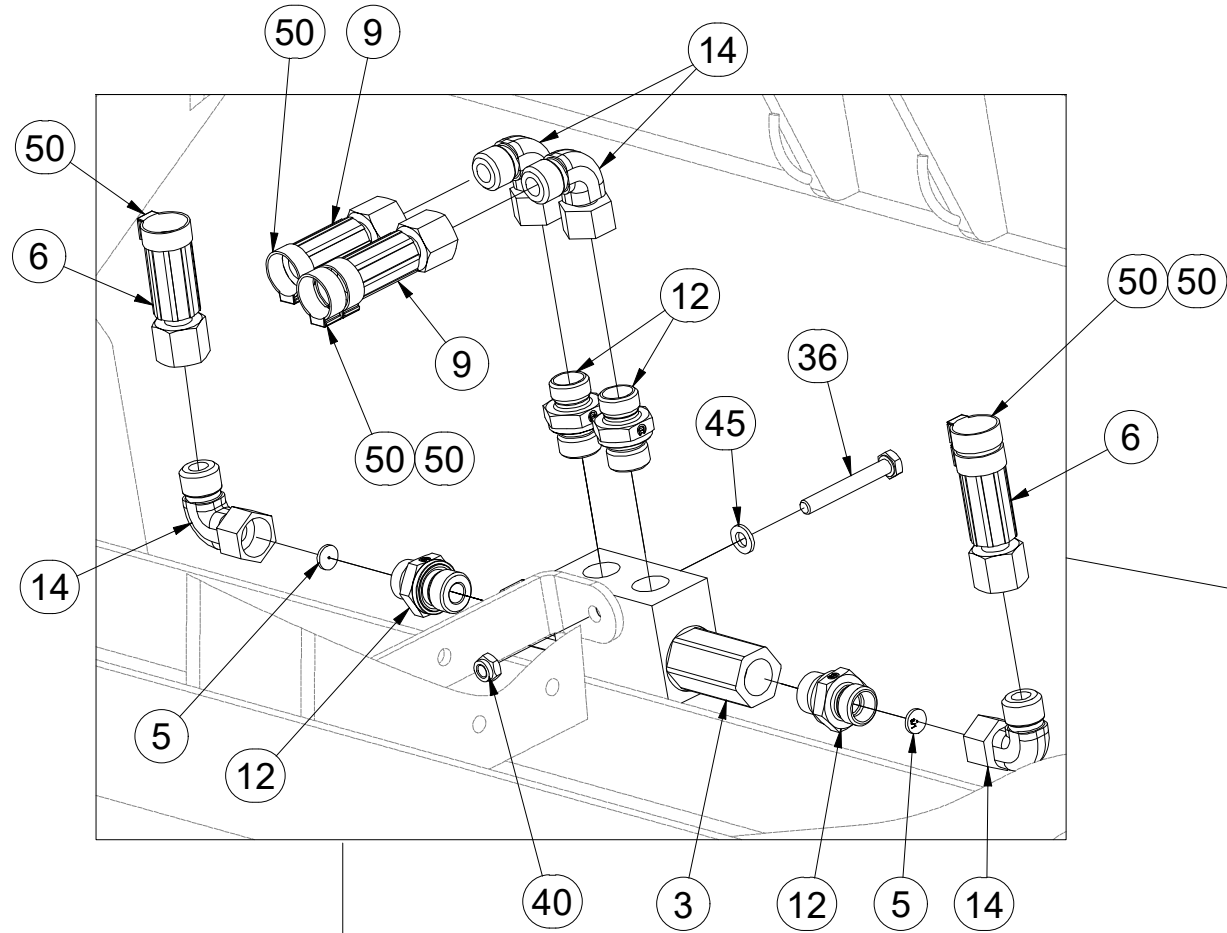

Pos.	Part Number	Pcs.
3	m06673	1
5	m10780	2
6	m03713	4
9	m04087	2
12	m06528	4
14	m06803	8
36	m05561	1
40	m05560	1
45	m01199	1
50	m11294	21

CZ HYDRAULIKA STROJE
 D HYDRAULIK DER MASCHINE
 F HYDRAULIQUE DE LA MACHINE

GB MACHINE HYDRAULICS
 RU ГИДРАВЛИКА МАШИНЫ
 PL HYDRAULIKA MASZYNY



3011328

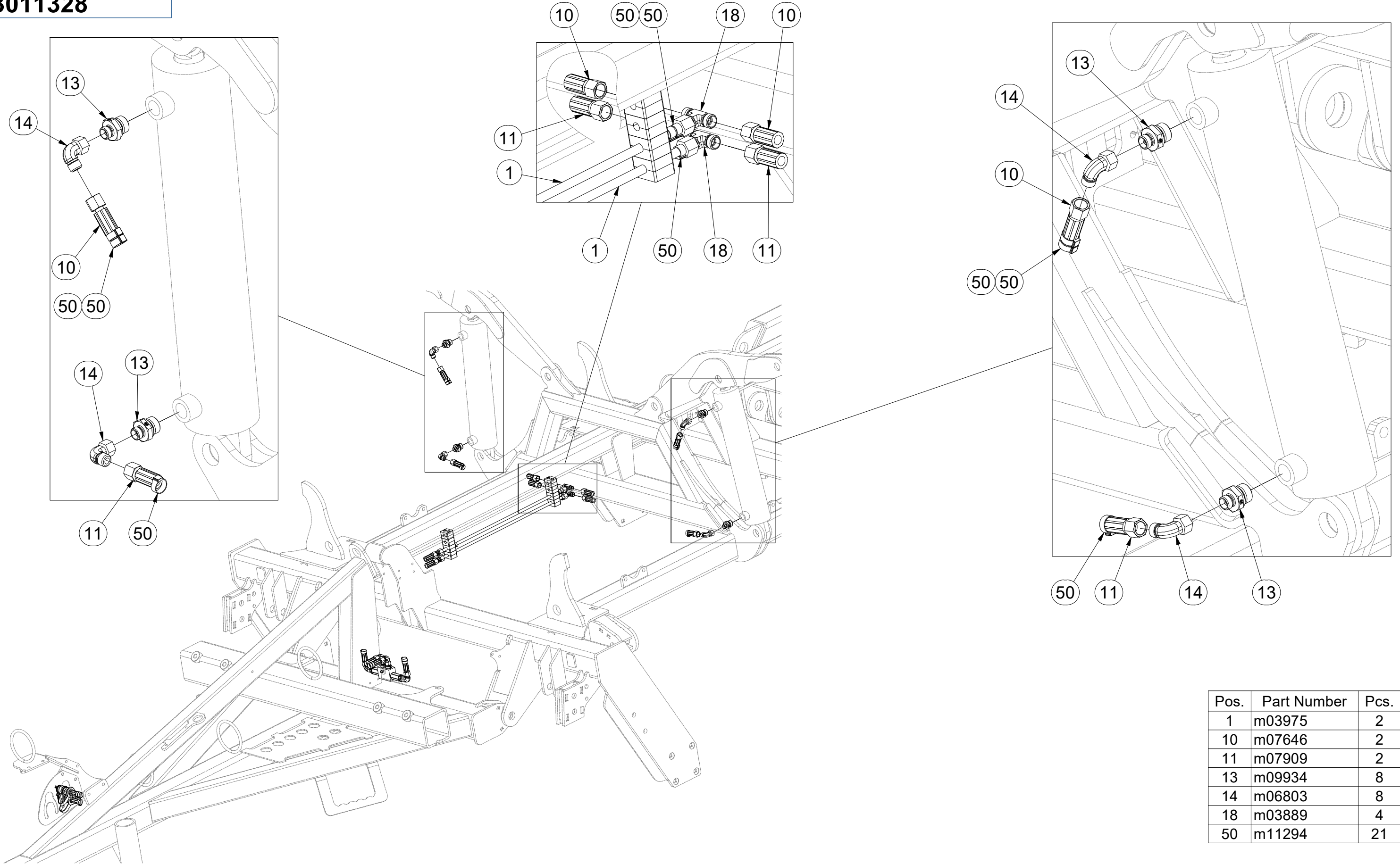

Pos.	Part Number	Pcs.
1	m03975	2
10	m07646	2
11	m07909	2
13	m09934	8
14	m06803	8
18	m03889	4
50	m11294	21

Ⓒ CZ OJ T3

Ⓓ DEICHSEL T3

Ⓕ TIMON T3

3012414

Ⓖ GB TOW BAR T3

Ⓡ RU ДЫШЛО T3

Ⓟ PL DYSZEL T3

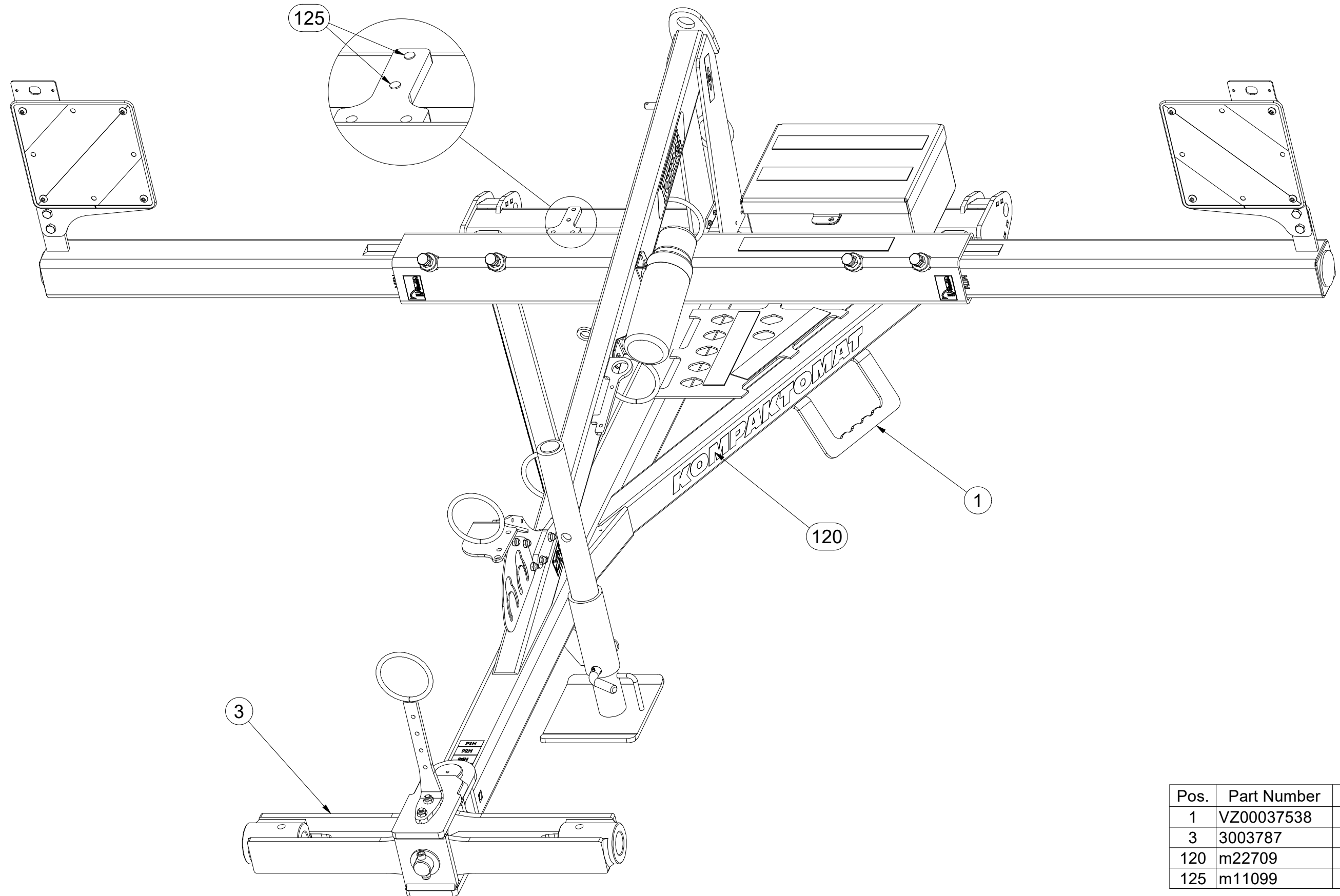

Pos.	Part Number	Pcs.
1	VZ00037538	1
3	3003787	1
120	m22709	1
125	m11099	2

Ⓒ CZ OJ T3

Ⓓ DEICHSEL T3

Ⓕ TIMON T3

Ⓖ GB TOW BAR T3

Ⓡ RU ДЫШЛО T3

Ⓟ PL DYSZEL T3



3012414

Pos.	Part Number	Pcs.	Pos.	Part Number	Pcs.
1	VZ00037538	1	72	m04613	2
2	3009637	1	74	m03926	2
3	3003787	1	75	m03681	3
4	4003744	2	76	m14008	2
5	4008049	1	86	m03775	5
6	4014570	1	88	m04301	8
10	8000647-40207	1	90	m02533	1
11	4012205	1	101	m03866	1
13	3012460	1	102	4013139	2
15	4019191	1	110	m10451	1
17	4008679	1	115	m03959	1
30	m10454	1			

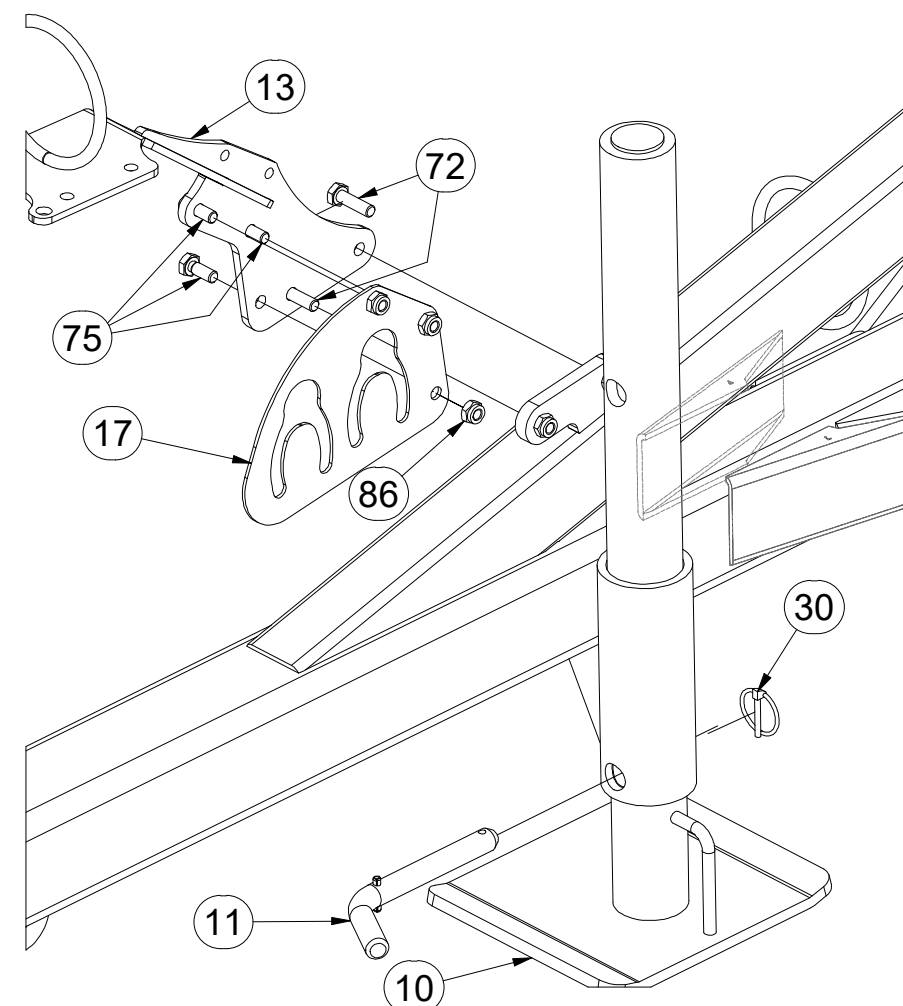
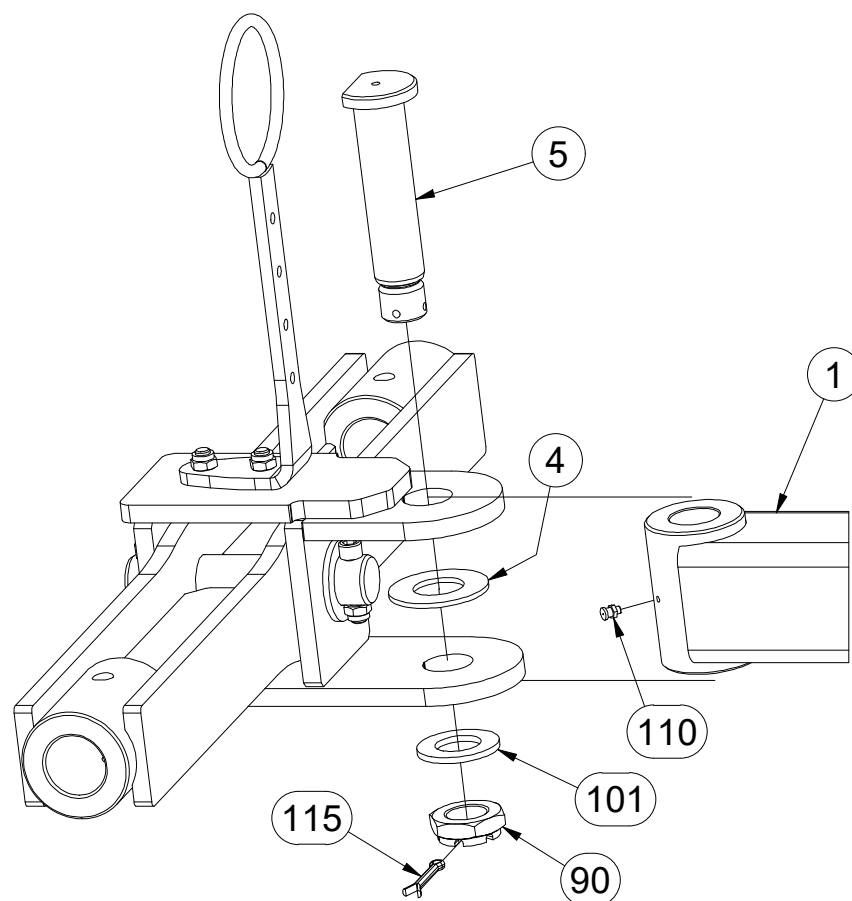
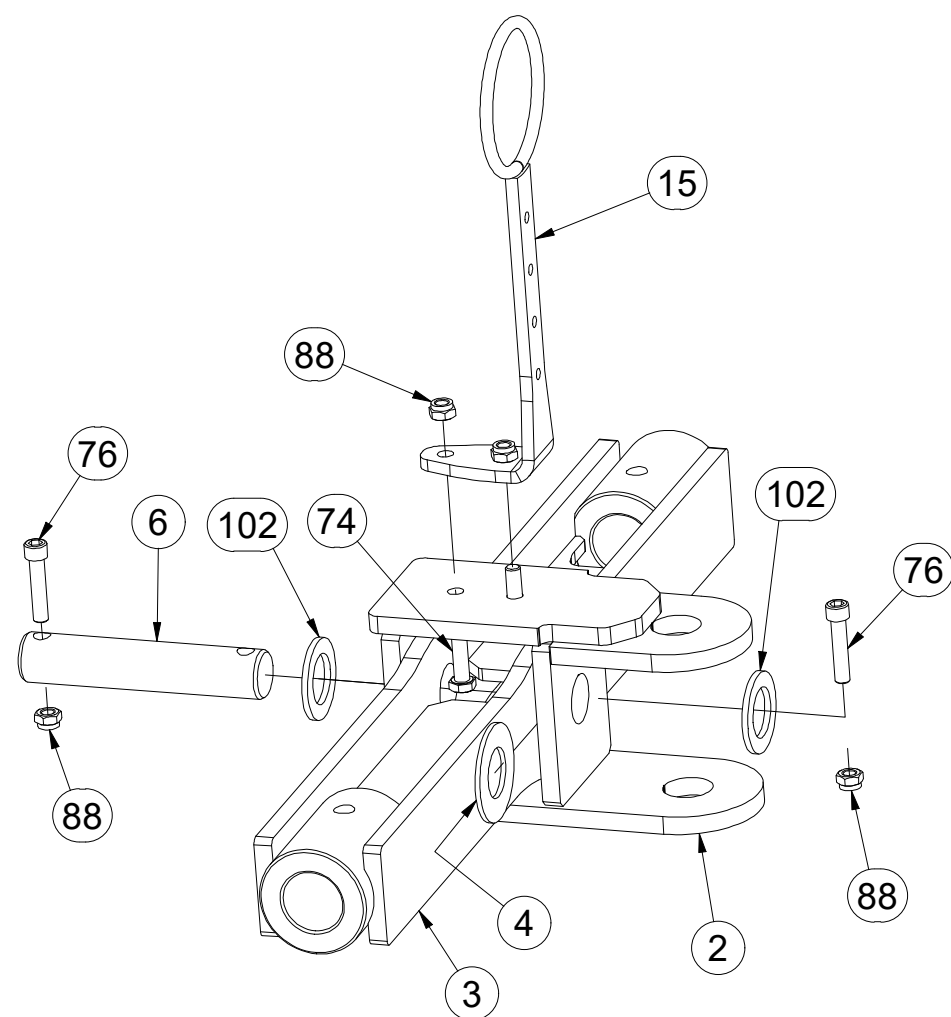
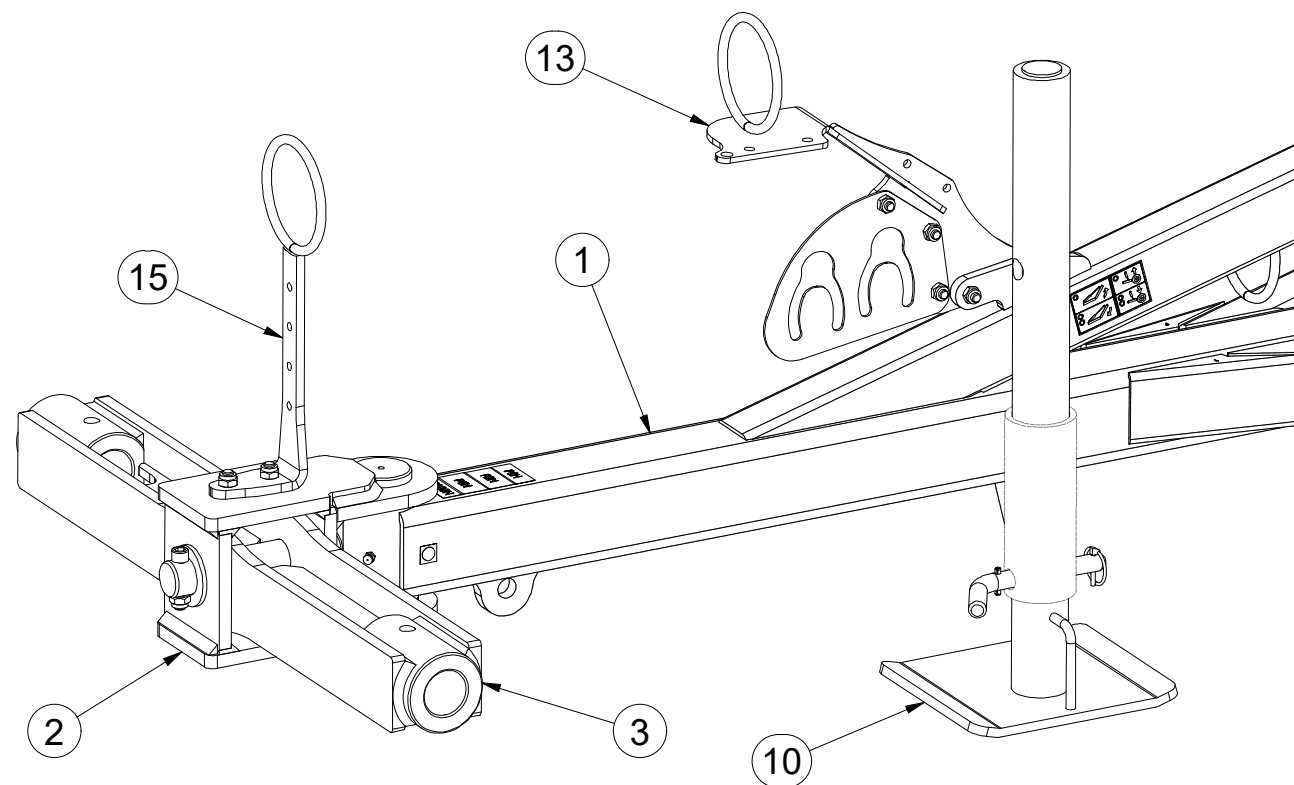

Ⓒ CZ OJ T3

Ⓓ DEICHSEL T3

Ⓕ TIMON T3

Ⓖ GB TOW BAR T3

Ⓡ RU ДЫШЛО T3

Ⓟ PL DYSZEL T3



3012414

Pos.	Part Number	Pcs.	Pos.	Part Number	Pcs.
1	VZ00037538	1	73	m04039	4
7	4019255	2	77	m02254	4
8	VZ00024252	1	78	m17098	2
9	VZ00024253	1	85	m05560	4
12	m12296	1	87	m04503	3
14	4013461	1	88	m04301	8
31	m15900	1	89	m01306	4
50	m02579	2	100	m07936	3
70	m01074	2	103	m16612	4
71	m01092	3			

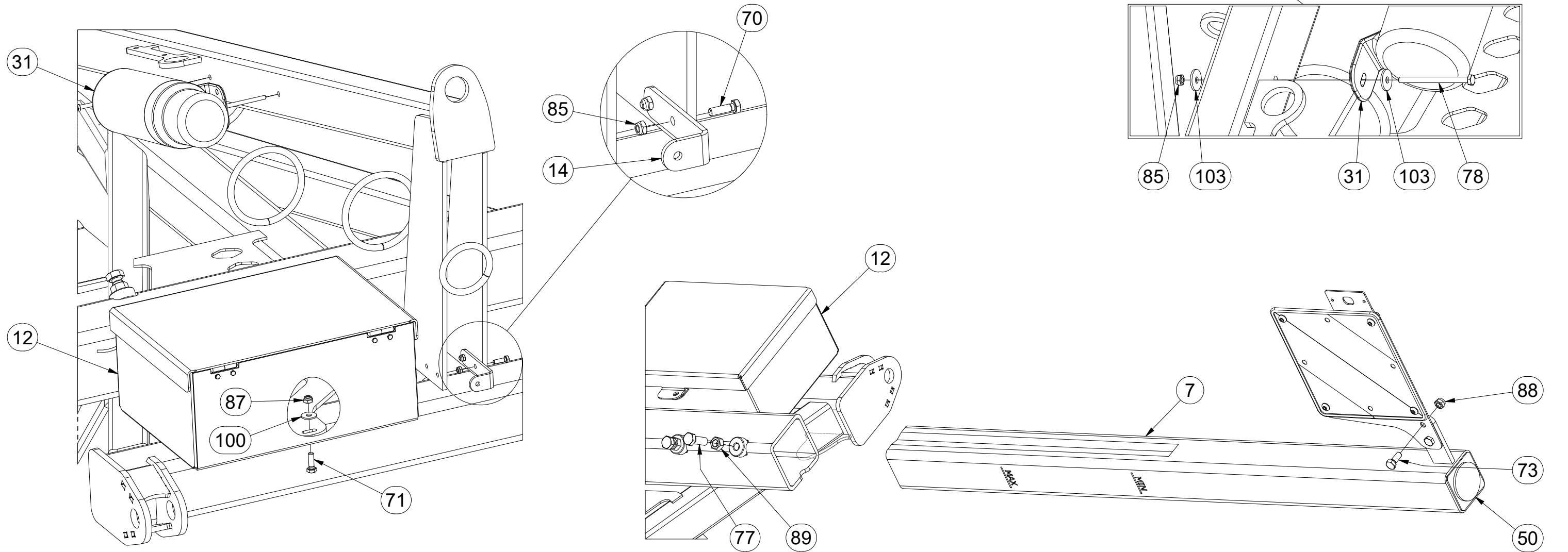
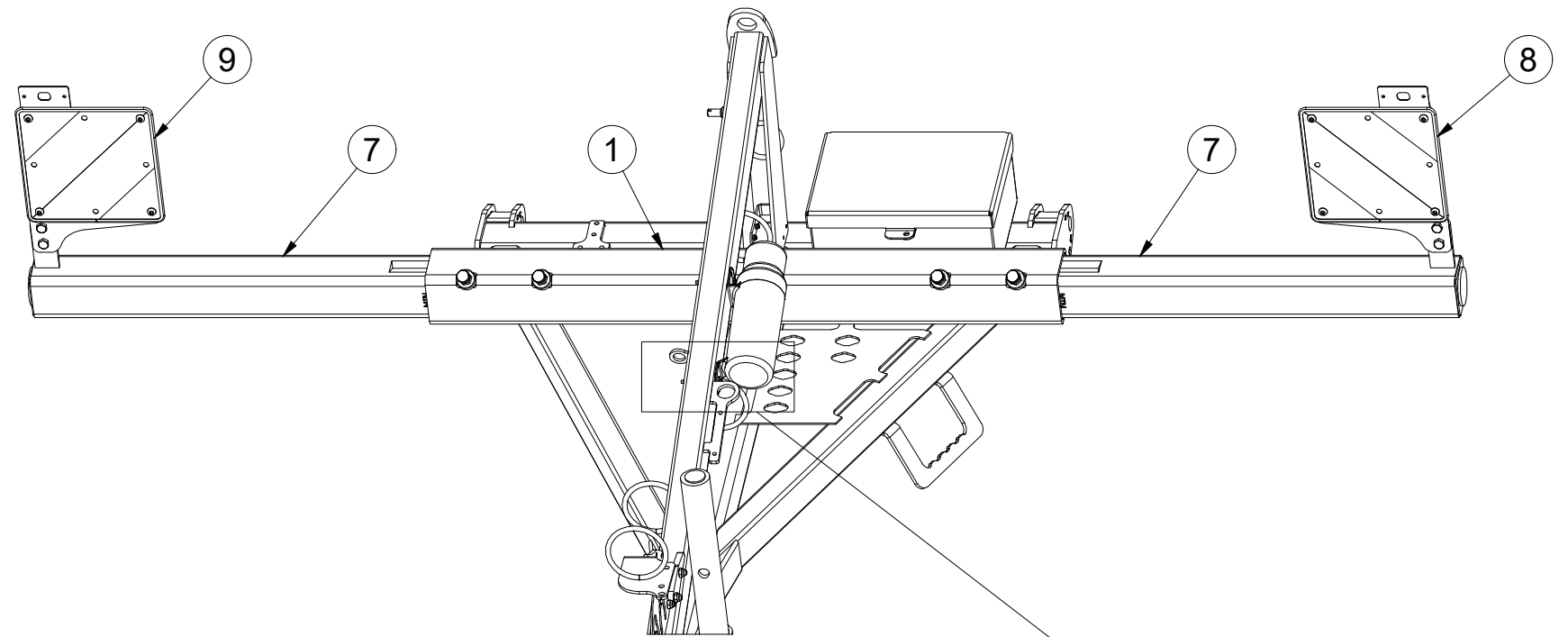

Ⓒ CZ OJ T3

Ⓓ DEICHSEL T3

Ⓕ TIMON T3

m22709

Ⓖ GB TOW BAR T3

Ⓡ RU ДЫШЛО T3

Ⓟ PL DYSZEL T3

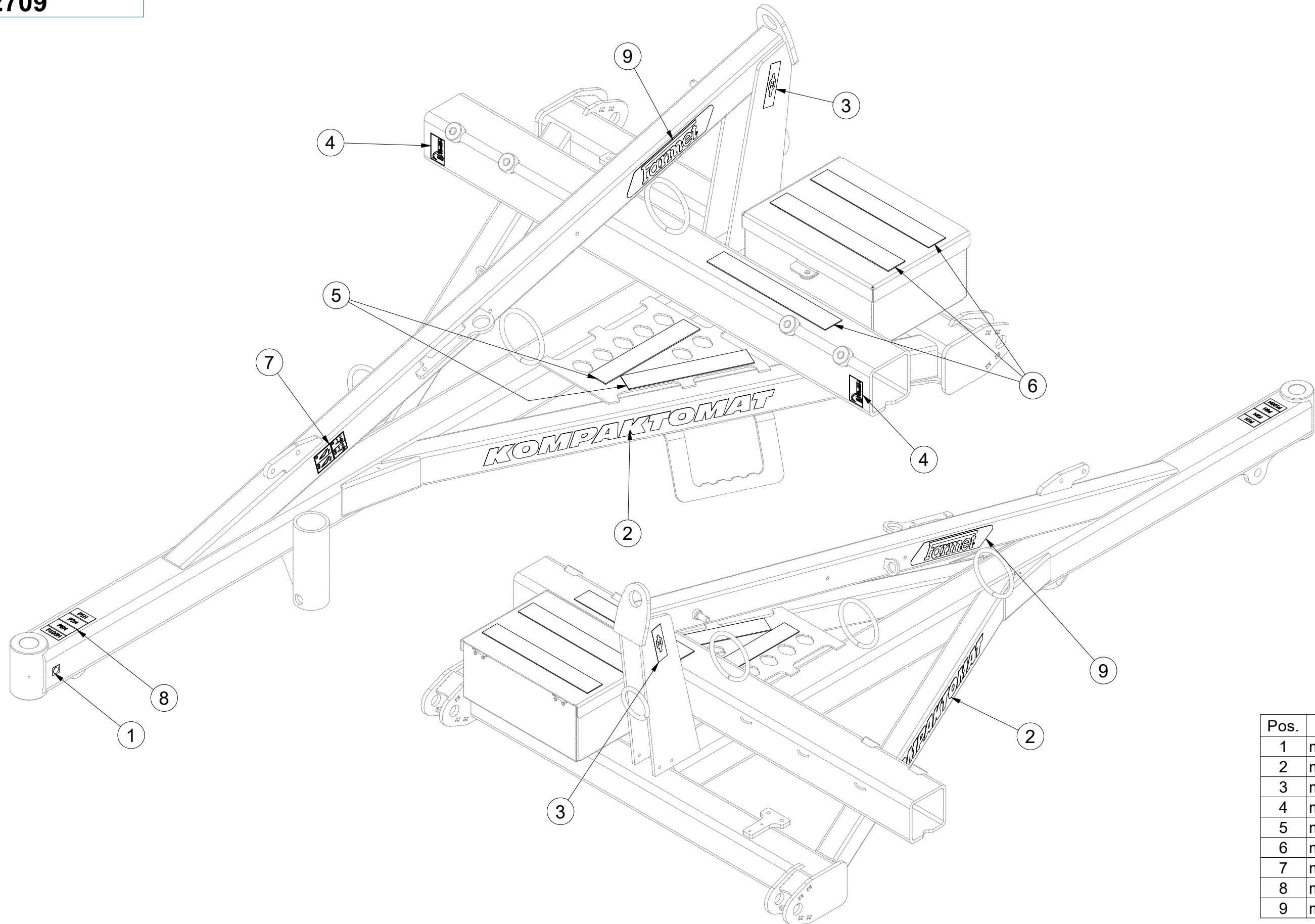

Pos.	Part Number	Pcs.
1	m03320	1
2	m07688	2
3	m03316	2
4	m10180	2
5	m11147	2
6	m11146	3
7	m11291	1
8	m11295	1
9	m13116	2

Ⓒ SADA ČEPŮ TBZ 3

Ⓓ BOLZENSATZ TBZ 3

Ⓕ KIT D'EMBOUITS TBZ 3

3011605

Ⓖ SET OF TBZ 3 PINS

Ⓡ КОМПЛЕКТ ПАЛЬЦЕВ TBZ 3

Ⓟ ZESTAW CZOPÓW TBZ 3

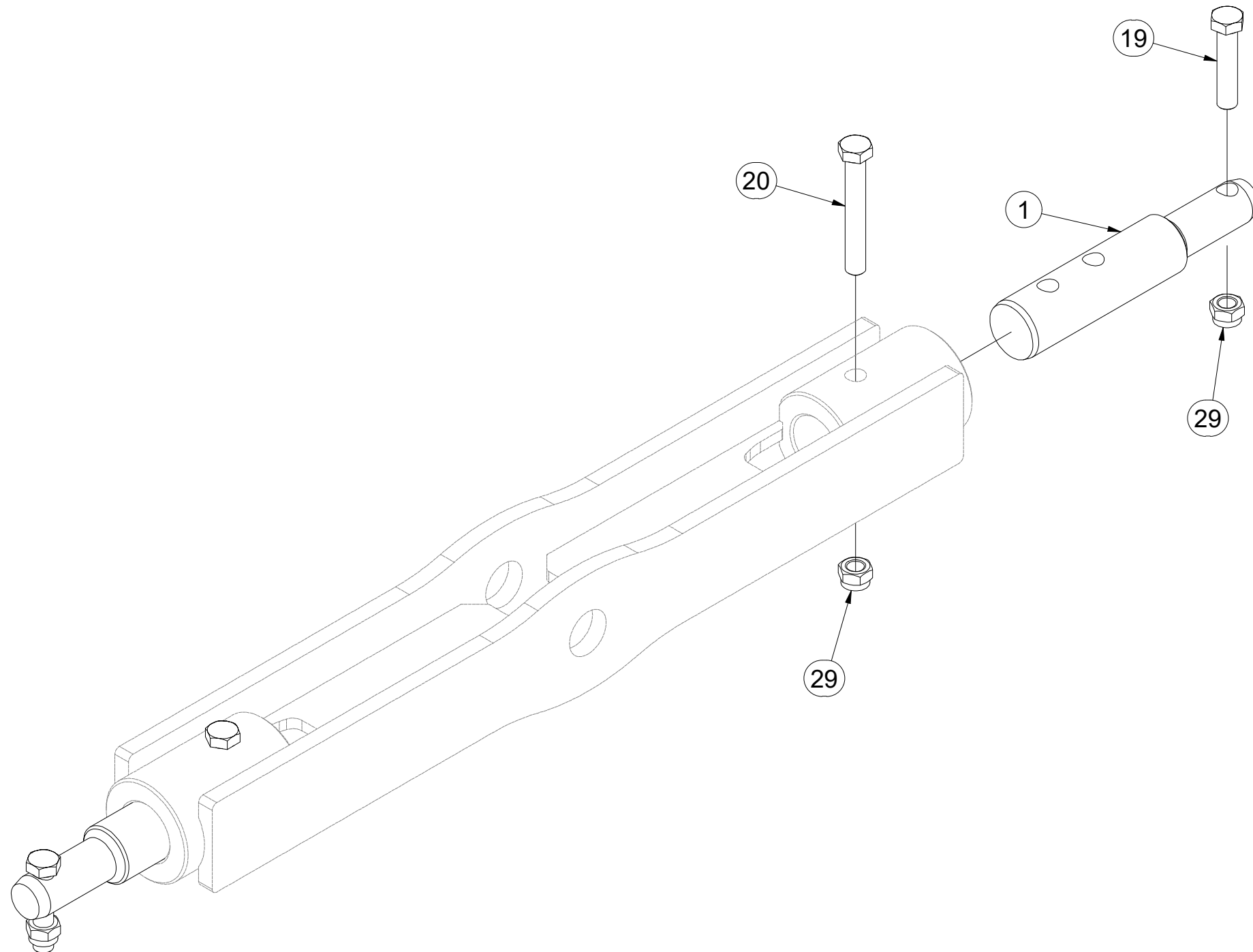
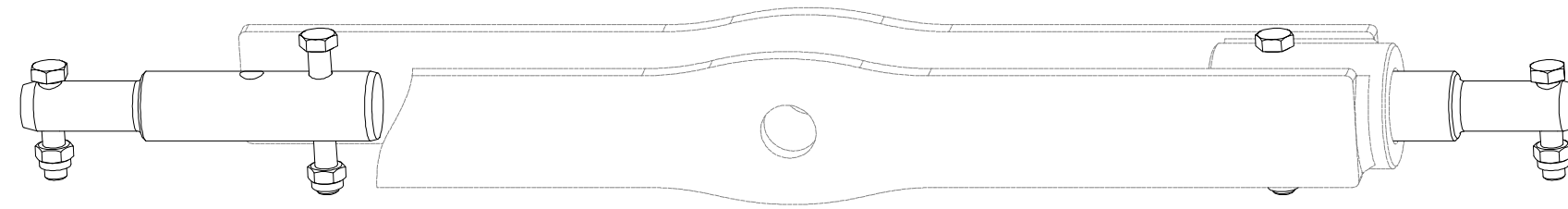

Pos.	Part Number	Pcs.
1	VZ00022884	2
19	m01133	2
20	m02970	2
29	m03683	4

CZ TERČ PŘEDNÍ LEVÝ
 D SCHILD, VORDERES, LINKES
 F CIBLE AVANT GAUCHE

GB LEFT FRONT DISC
 RU ЩИТОК ПЕРЕДНИЙ ЛЕВЫЙ
 PL TARCZA PRZEDNIA LEWA



VZ00024252

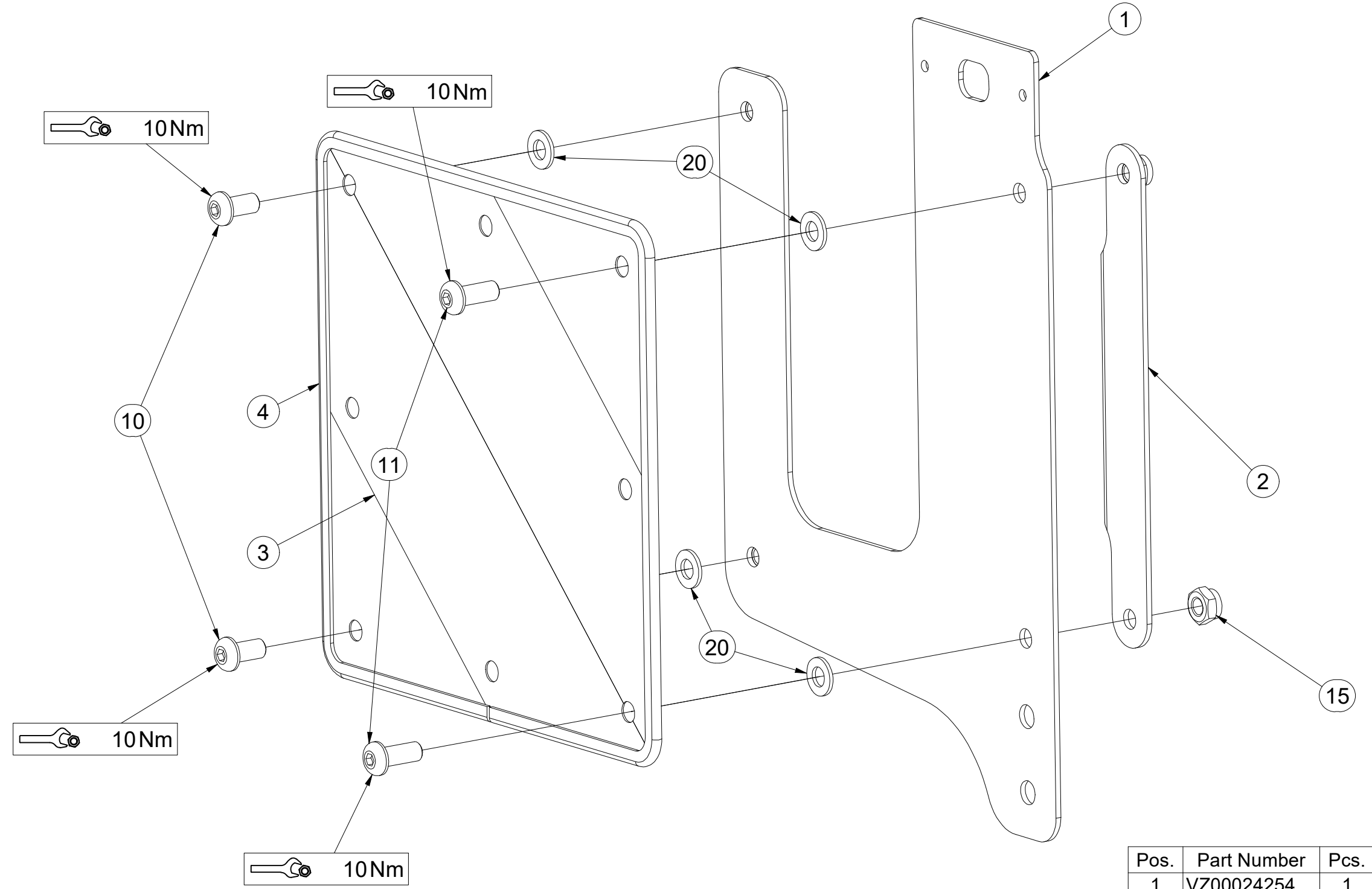

Pos.	Part Number	Pcs.
1	VZ00024254	1
2	VZ00024261	1
3	m18855	1
4	9005707	1
10	m16637	2
11	m16688	2
15	m03775	4
20	m01209	4

ⒸZ TERČ PŘEDNÍ PRAVÝ

Ⓓ SCHILD, VORDERES, RECHTES

Ⓕ CIBLE AVANT DROITE

ⒸB RIGHT FRONT DISC

ⒺЩИТОК ПЕРЕДНИЙ ПРАВЫЙ

Ⓖ TARCZA PRZEDNIA PRAWA



VZ00024253

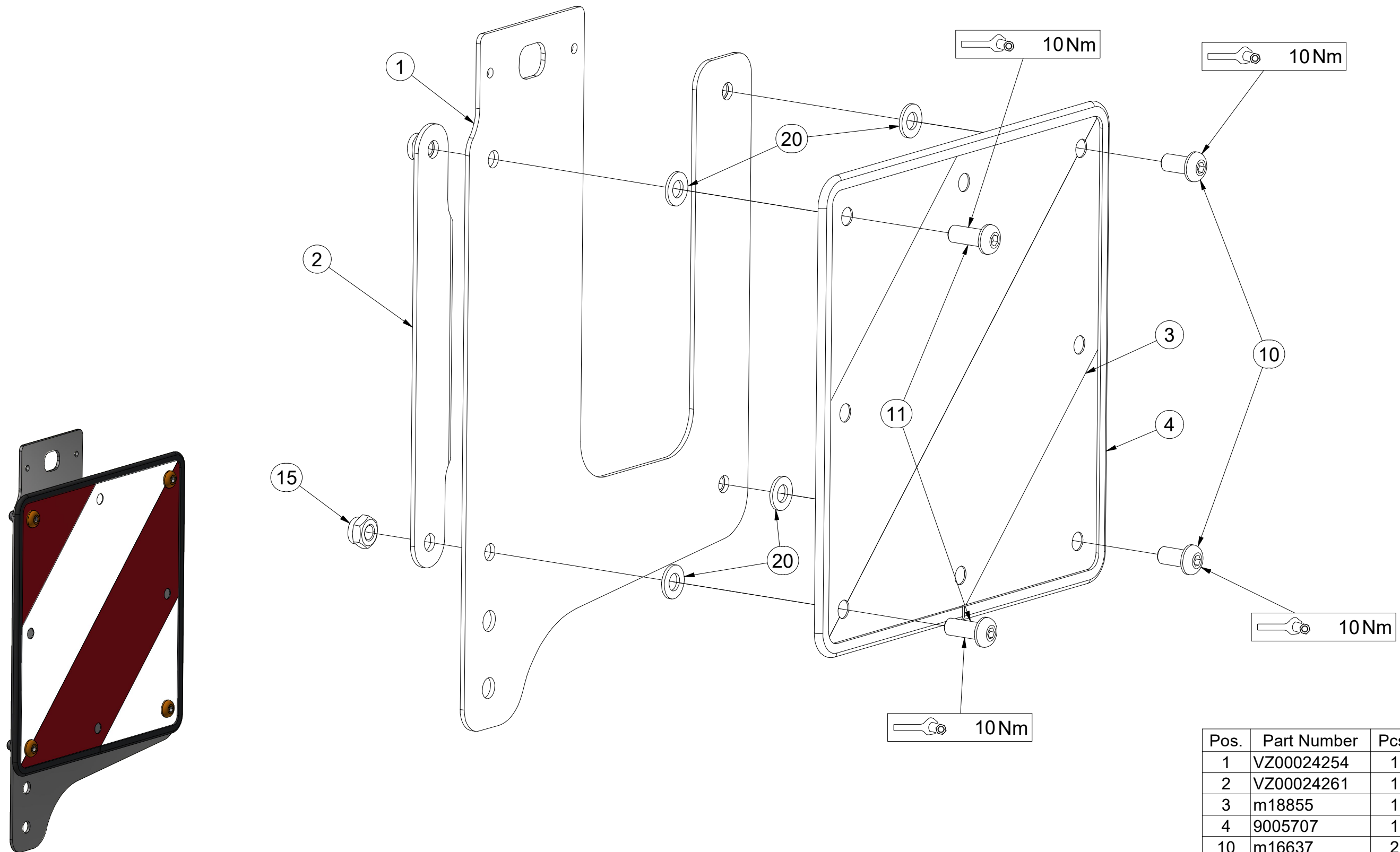

Pos.	Part Number	Pcs.
1	VZ00024254	1
2	VZ00024261	1
3	m18855	1
4	9005707	1
10	m16637	2
11	m16688	2
15	m03775	4
20	m01209	4

Ⓒ SADA KYPŘIČŮ STOP

Ⓓ SPURENLOCKERERSATZ

Ⓕ KIT DE CULTIVATEURS DE TRACES

3005535

Ⓖ SET OF TRACK CULTIVATORS

Ⓡ КОМПЛЕКТ РЫХЛИТЕЛЕЙ КОЛЕИ

Ⓢ ZESTAW SPULCHNIACZY ŚLADÓW

Farmet

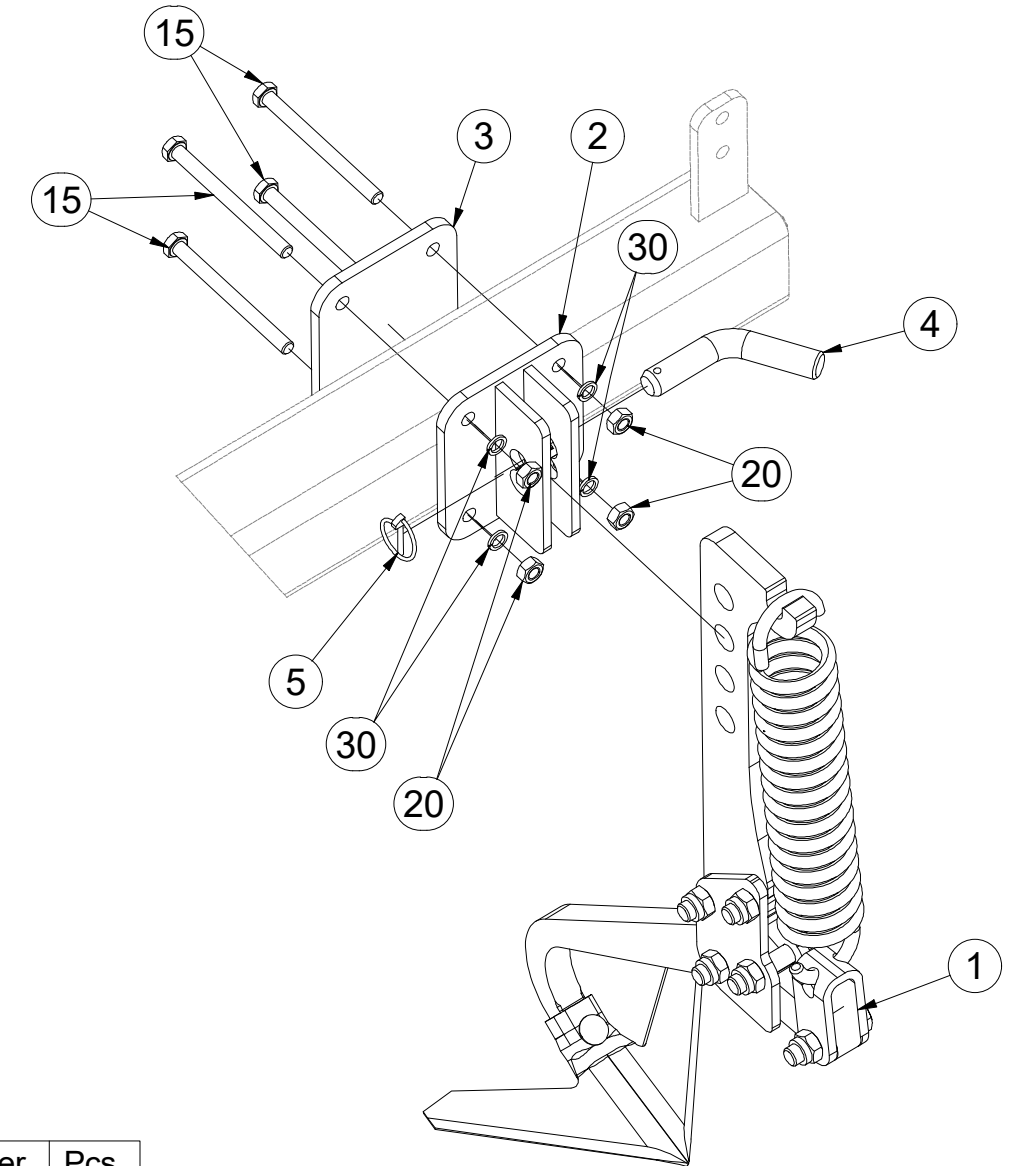
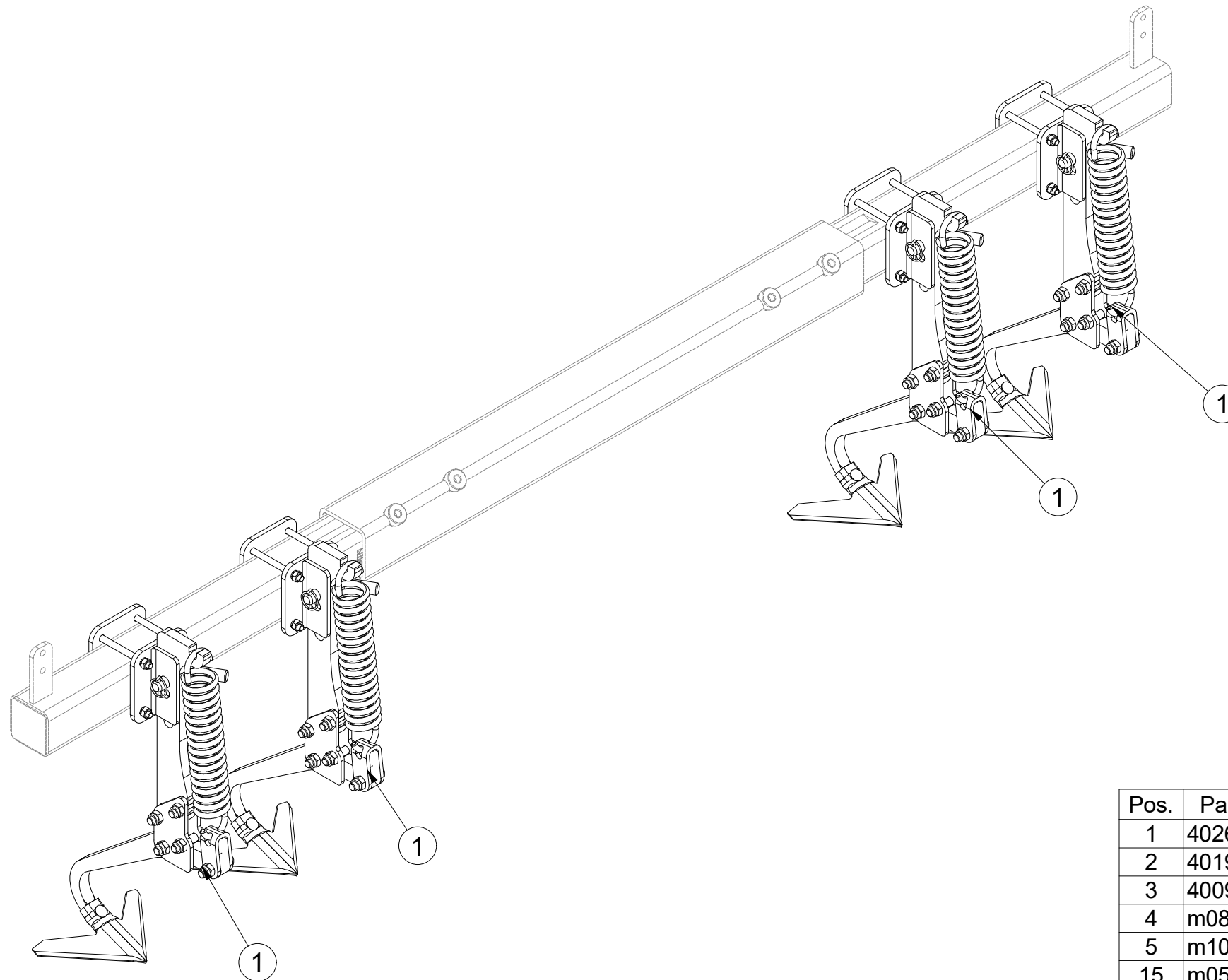

Pos.	Part Number	Pcs.
1	4026045	4
2	4019042	4
3	4009468	4
4	m08885	4
5	m10454	4
15	m05946	16
20	m01305	16
30	m03988	16

Ⓒ KYPŘIČ STOP

Ⓓ SPURENLOCKERER

Ⓕ CULTIVATEUR DES TRACES

Ⓒ TRACK CULTIVATOR

Ⓔ РЫХЛИТЕЛЬ КОЛЕИ

Ⓗ SPULCHNIARKA STÓP



4026045

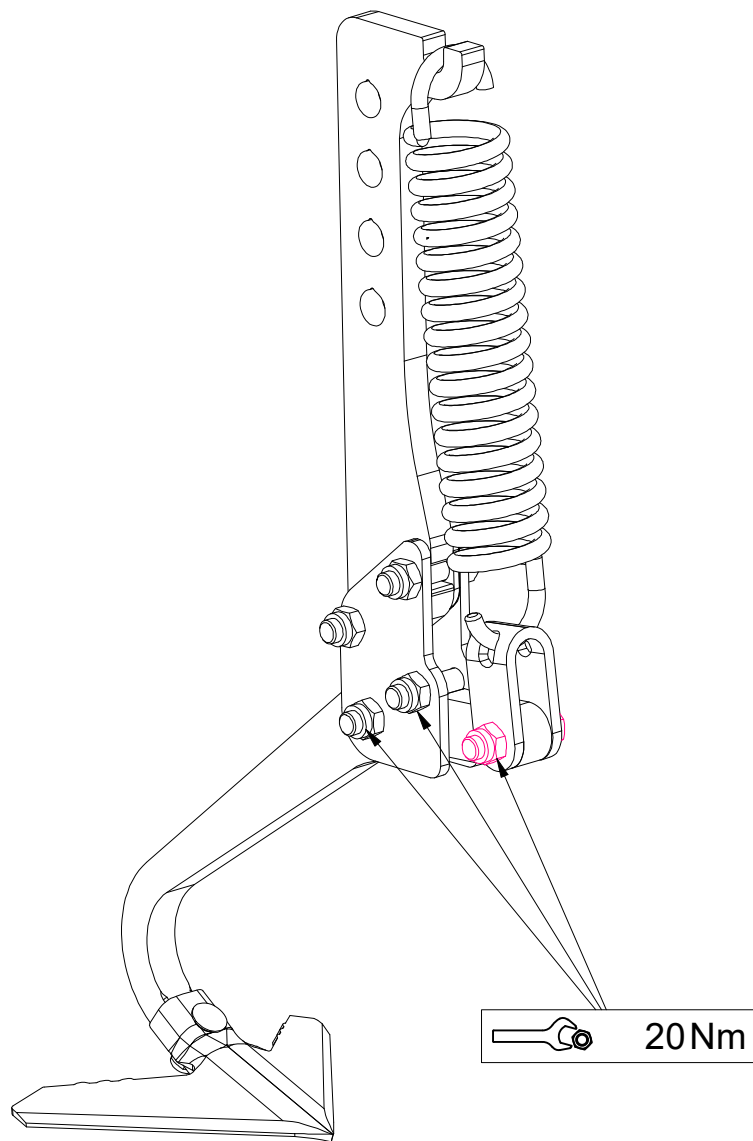

Pos.	Part Number	Pcs.
1	4017307	1
2	4025591	1
3	4005582	2
4	3000236-KOO	1
5	4005445	1
6	m02597	1
7	4005591	1
8	4026202	1
20	m10440	1
22	m06587	5
30	m21001	1
31	m03683	5

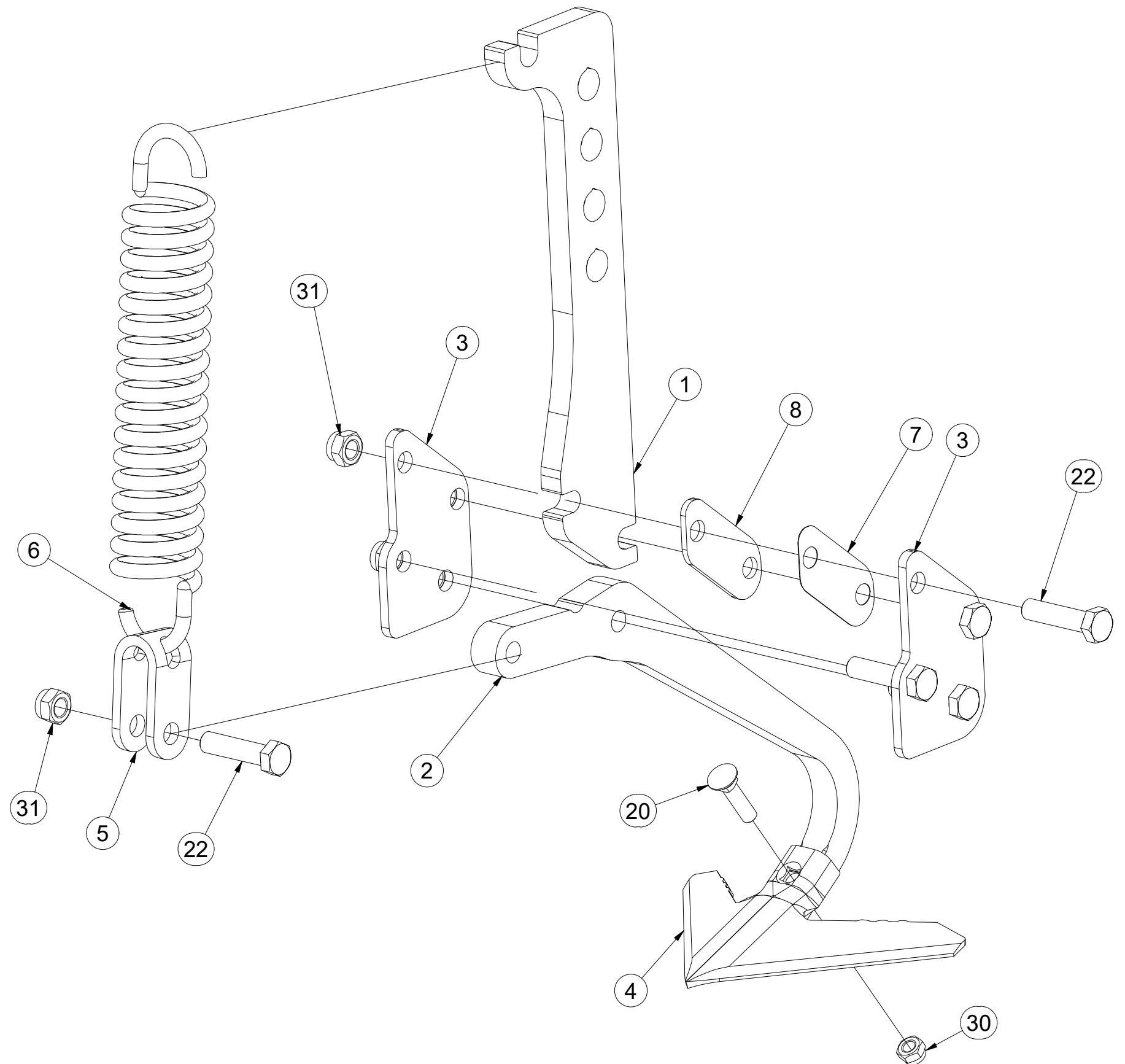

Ⓒ SADA PŘEDNÍCH SMYKŮ

Ⓓ SATZ VORDERE ACKERSCHLEPPEN

Ⓕ KIT DE NIVELEURS AVANT

Ⓖ SET OF FRONT LEVELLING BARS

Ⓡ КОМПЛЕКТ ПЕРЕДНИХ БОРОН

Ⓢ ZESTAW PRZEDNICH WŁÓK

Farmet

VZ00038805

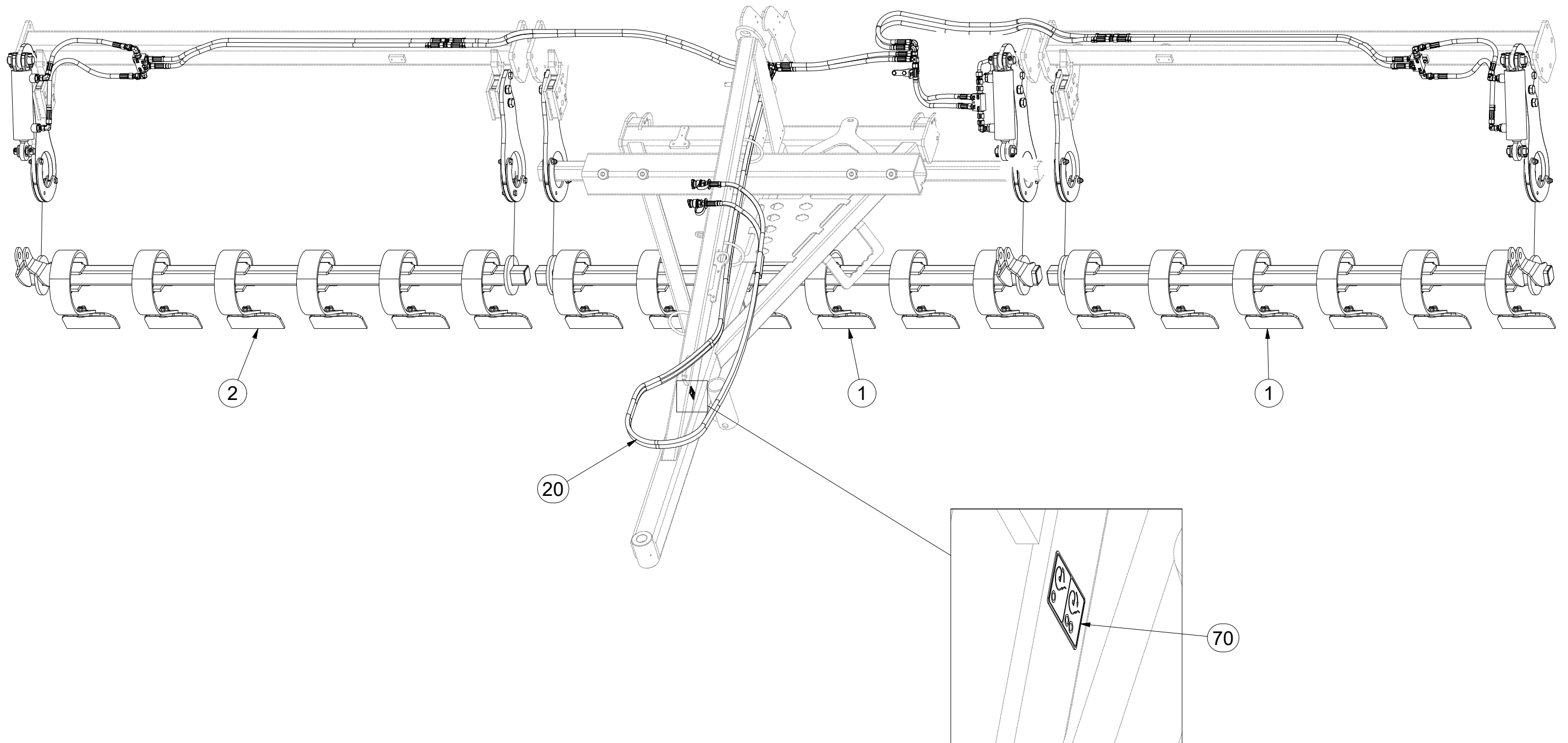

Pos.	Part Number	Pcs.
1	VZ00005418	2
2	VZ00010118	1
20	VZ00037573	1
70	m20272	1

ⒸZ SADA PŘEDNÍCH SMYKŮ

Ⓓ SATZ VORDERE ACKERSCHLEPPEN

Ⓕ KIT DE NIVELEURS AVANT

ⒸB SET OF FRONT LEVELLING BARS

ⒸU КОМПЛЕКТ ПЕРЕДНИХ БОРОН

ⒸL ZESTAW PRZEDNICH WŁÓK



VZ00038805

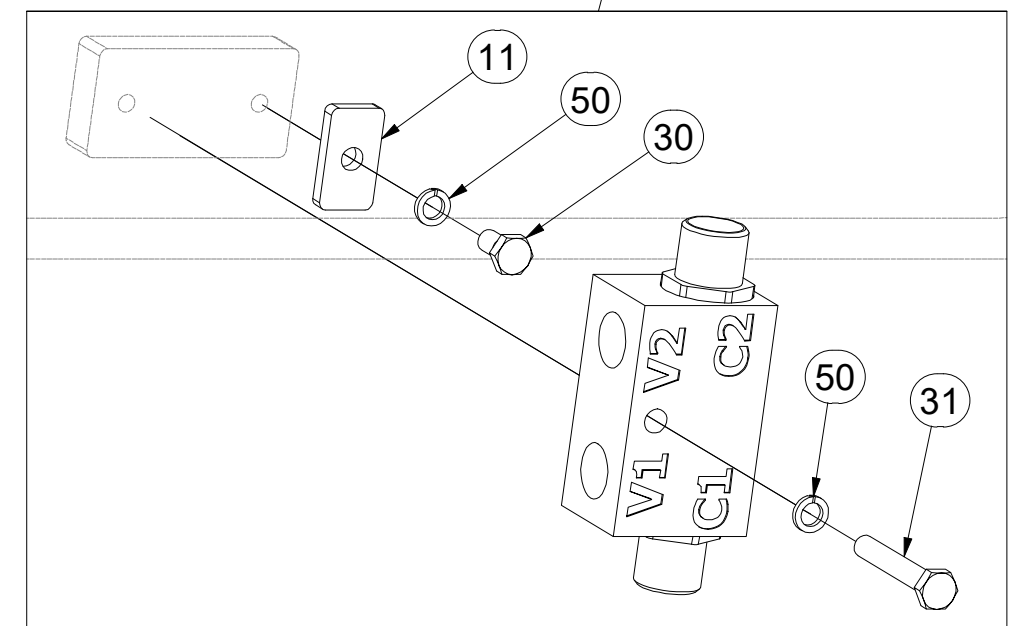
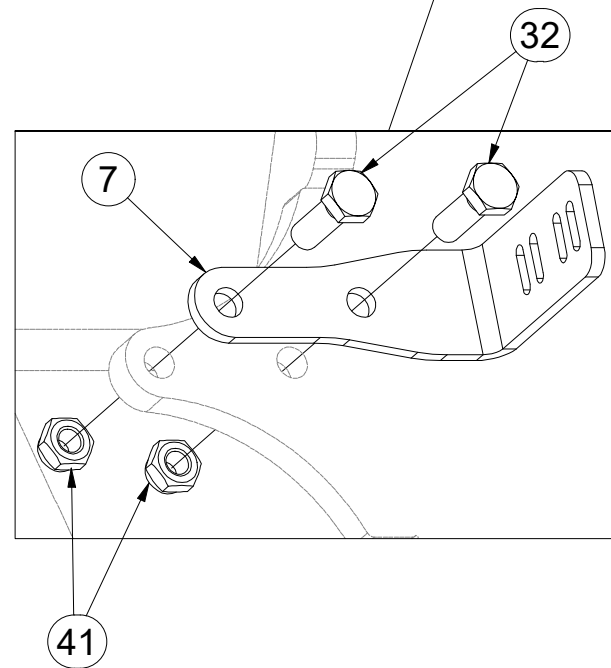
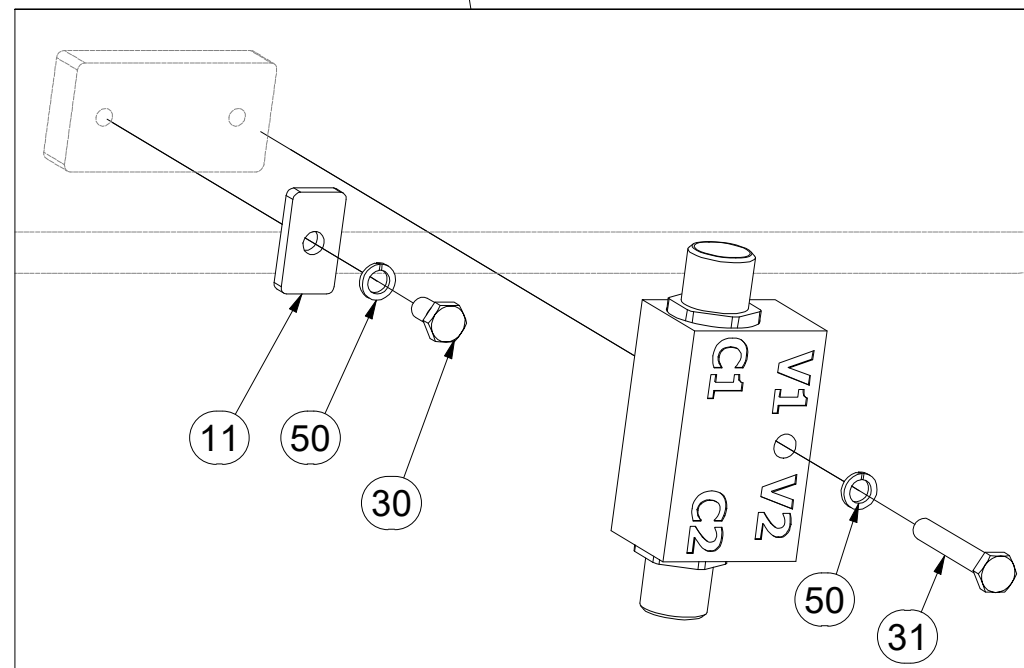
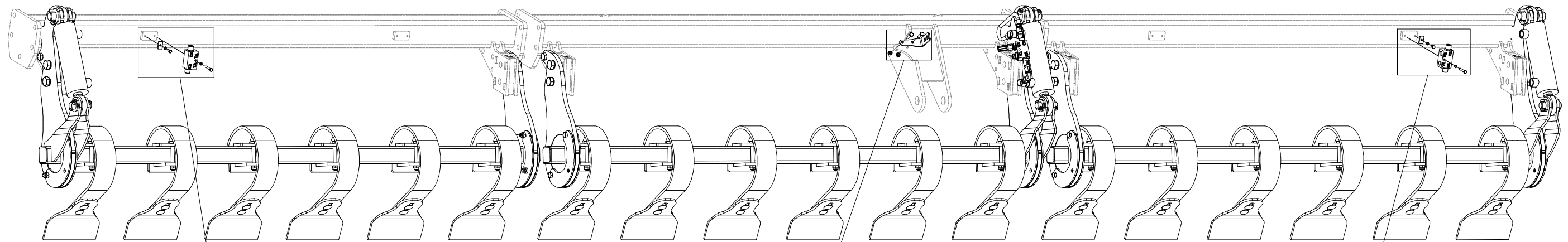

Pos.	Part Number	Pcs.
7	VZ00005362	1
11	VZ00037574	2
30	m05243	2
31	m04641	2
32	m01092	2
41	m04503	8
50	m01200	4

Ⓒ SADA PŘEDNÍCH SMYKŮ

Ⓓ SATZ VORDERE ACKERSCHLEPPEN

Ⓕ KIT DE NIVELEURS AVANT

Ⓖ SET OF FRONT LEVELLING BARS

Ⓡ КОМПЛЕКТ ПЕРЕДНИХ БОРОН

Ⓟ ZESTAW PRZEDNICH WŁÓK



VZ00038805

Pos.	Part Number	Pcs.	Pos.	Part Number	Pcs.
1	VZ00005418	2	35	m06077	13
3	VZ00012151	3	36	m02254	6
4	VZ00012154	3	37	m08378	12
5	4018126	6	42	m04301	13
8	VZ00005460	12	43	m03683	6
9	VZ00013496	6	51	m06279	12
15	VZ00010003	24			

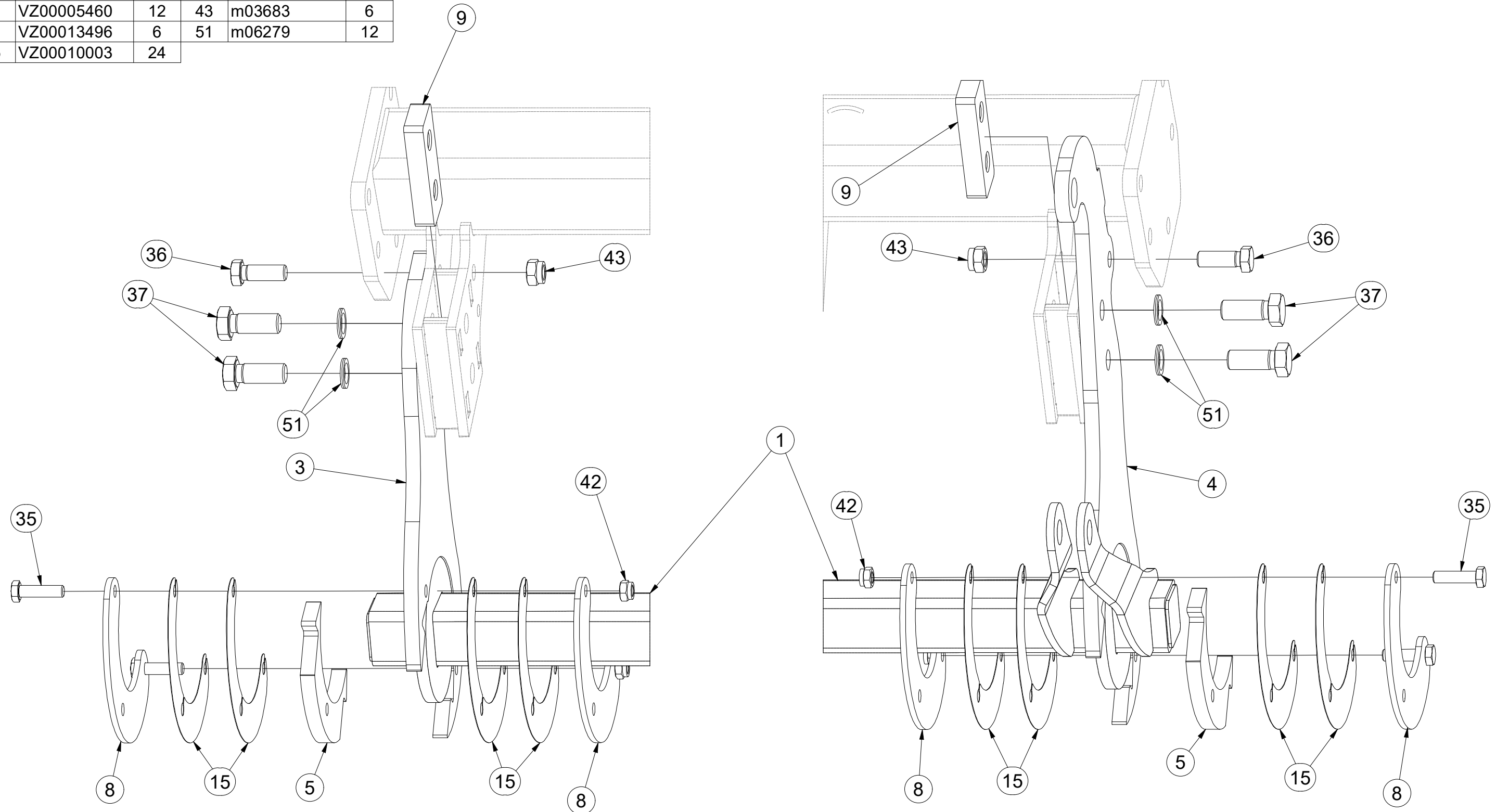
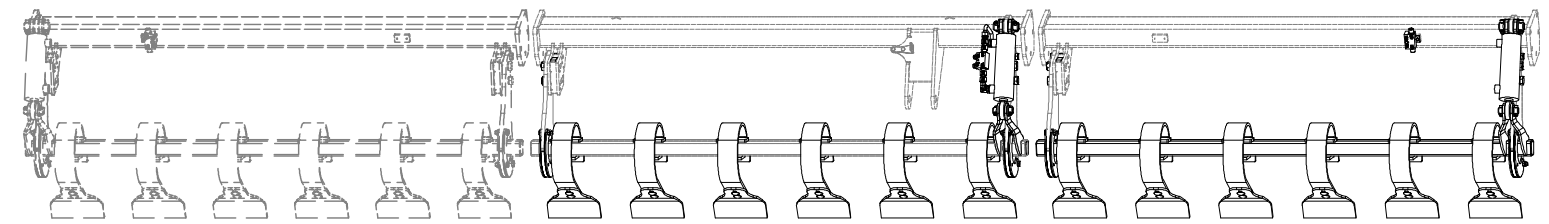

Ⓒ SADA PŘEDNÍCH SMYKŮ

Ⓓ SATZ VORDERE ACKERSCHLEPPEN

Ⓕ KIT DE NIVELEURS AVANT

Ⓖ SET OF FRONT LEVELLING BARS

Ⓡ КОМПЛЕКТ ПЕРЕДНИХ БОРОН

Ⓟ ZESTAW PRZEDNICH WŁÓK



VZ00038805

Pos.	Part Number	Pcs.
2	VZ00010118	1
3	VZ00012151	3
4	VZ00012154	3
5	4018126	6
8	VZ00005460	12
9	VZ00013496	6
15	VZ00010003	24
35	m06077	13
36	m02254	6
37	m08378	12
42	m04301	13
43	m03683	6
51	m06279	12

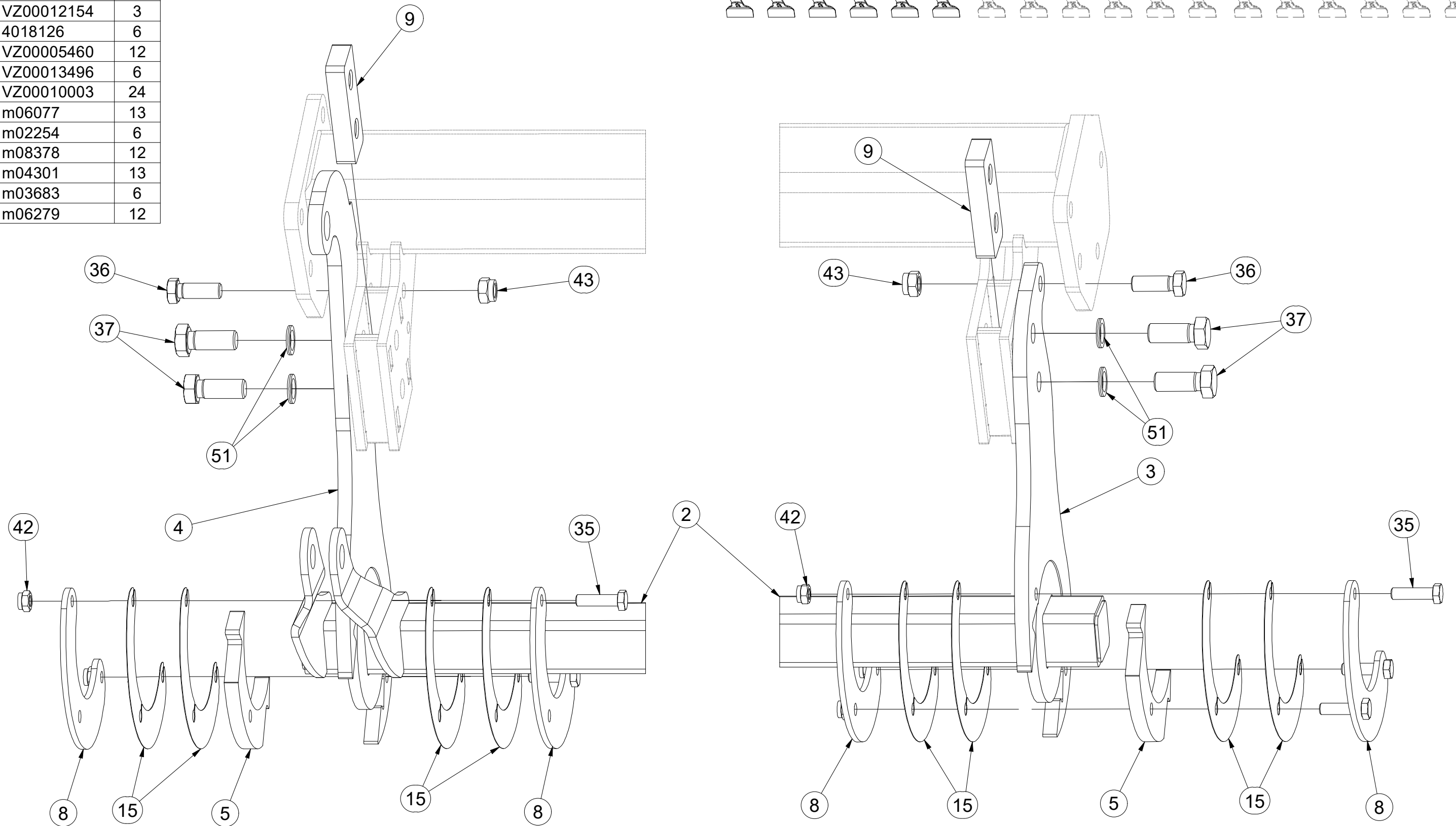
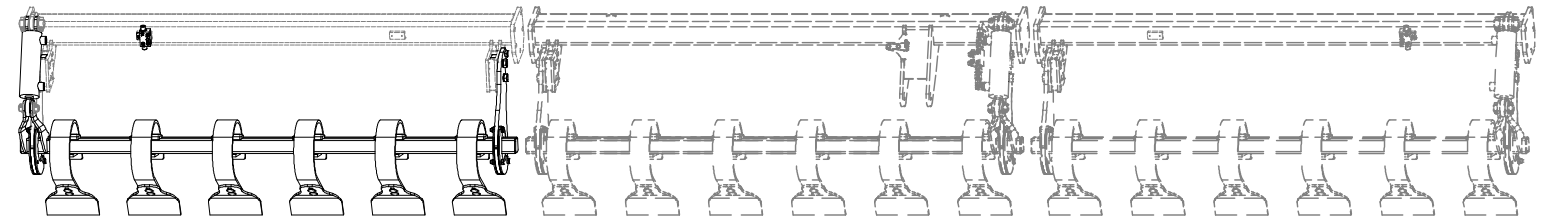

ⒸZ SADA PŘEDNÍCH SMYKŮ

Ⓓ SATZ VORDERE ACKERSCHLEPPEN

Ⓕ KIT DE NIVELEURS AVANT

ⒼB SET OF FRONT LEVELLING BARS

ⒺU КОМПЛЕКТ ПЕРЕДНИХ БОРОН

ⒽL ZESTAW PRZEDNICH WŁÓK



VZ00038805

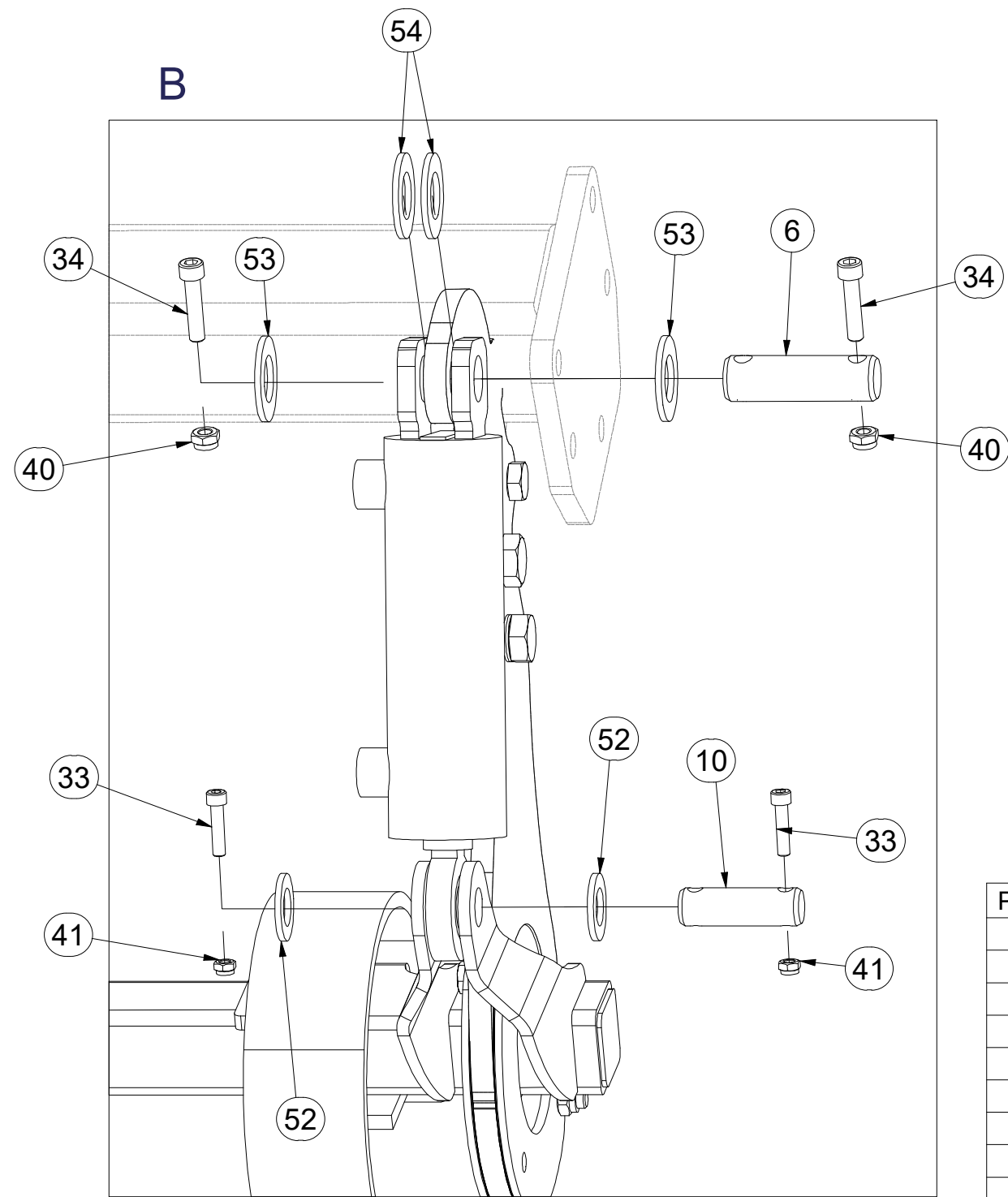
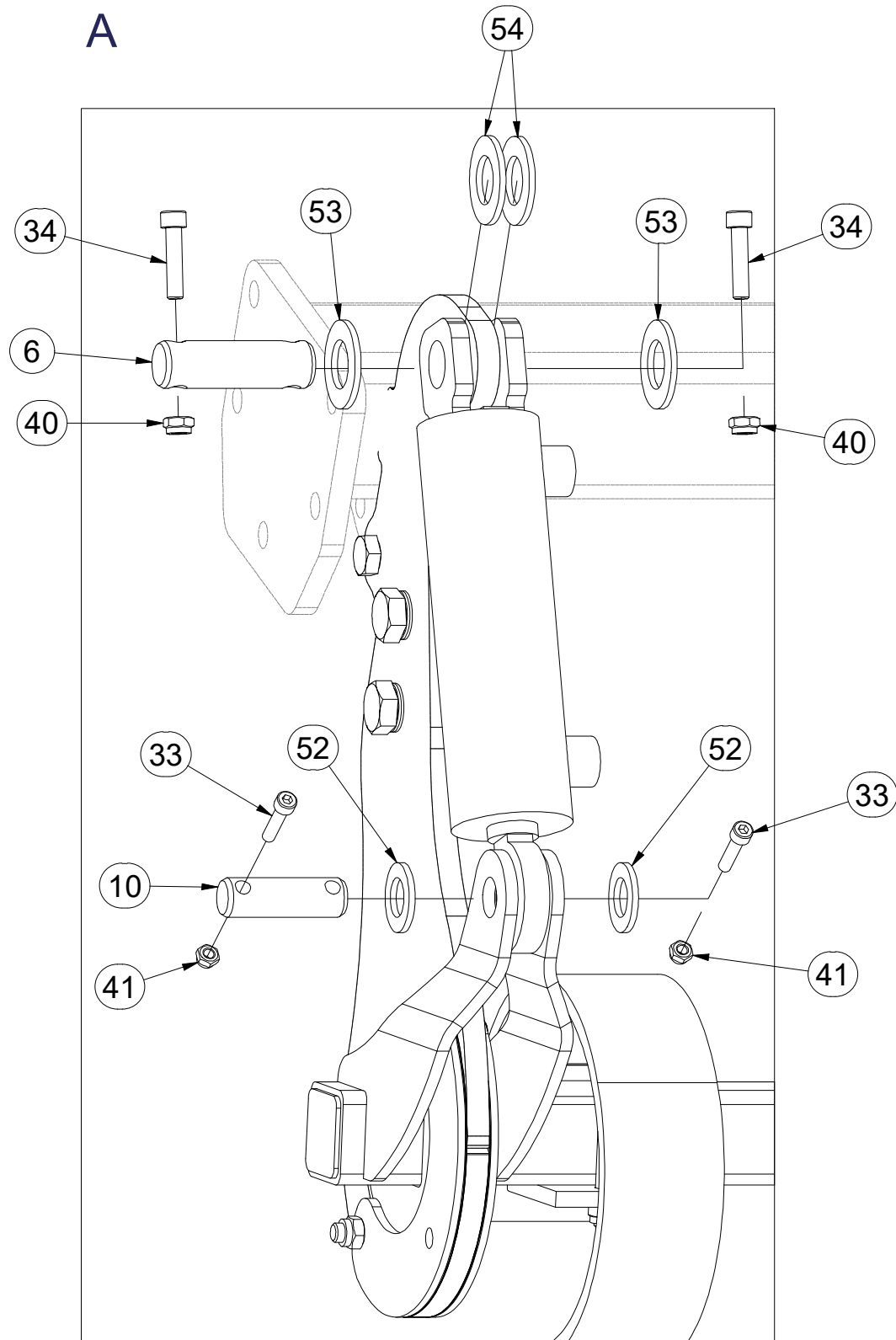
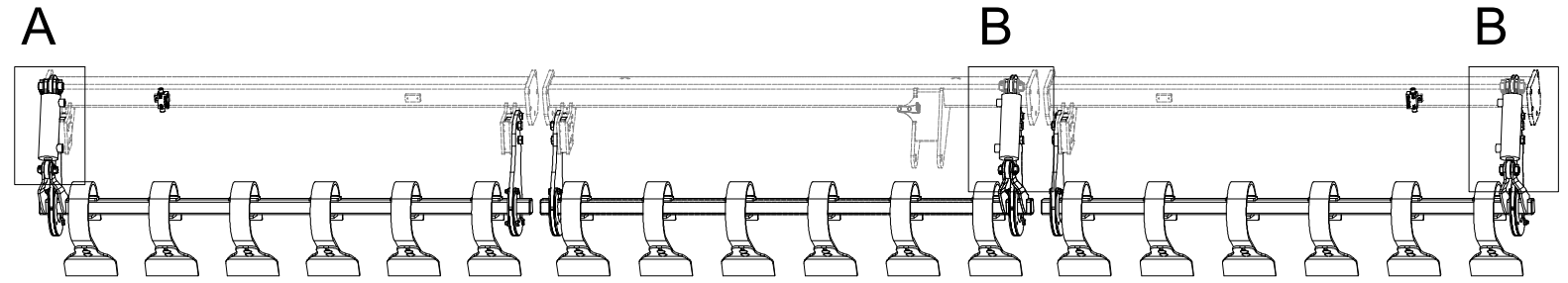

Pos.	Part Number	Pcs.
6	4008234	3
10	4007638	3
33	m09464	6
34	m14143	6
40	m03775	6
41	m04503	8
54	m02866	6
53	m14029	6
52	m14028	6

Ⓒ PŘEDNÍ SMYK

Ⓓ VORDERE ACKERSCHLEIFE

Ⓕ NIVELEUR AVANT

Ⓒ FRONT LEVELLER

Ⓓ ПЕРЕДНЯЯ БОРОНА

Ⓕ PRZEDNIA WŁÓKA



VZ00010118

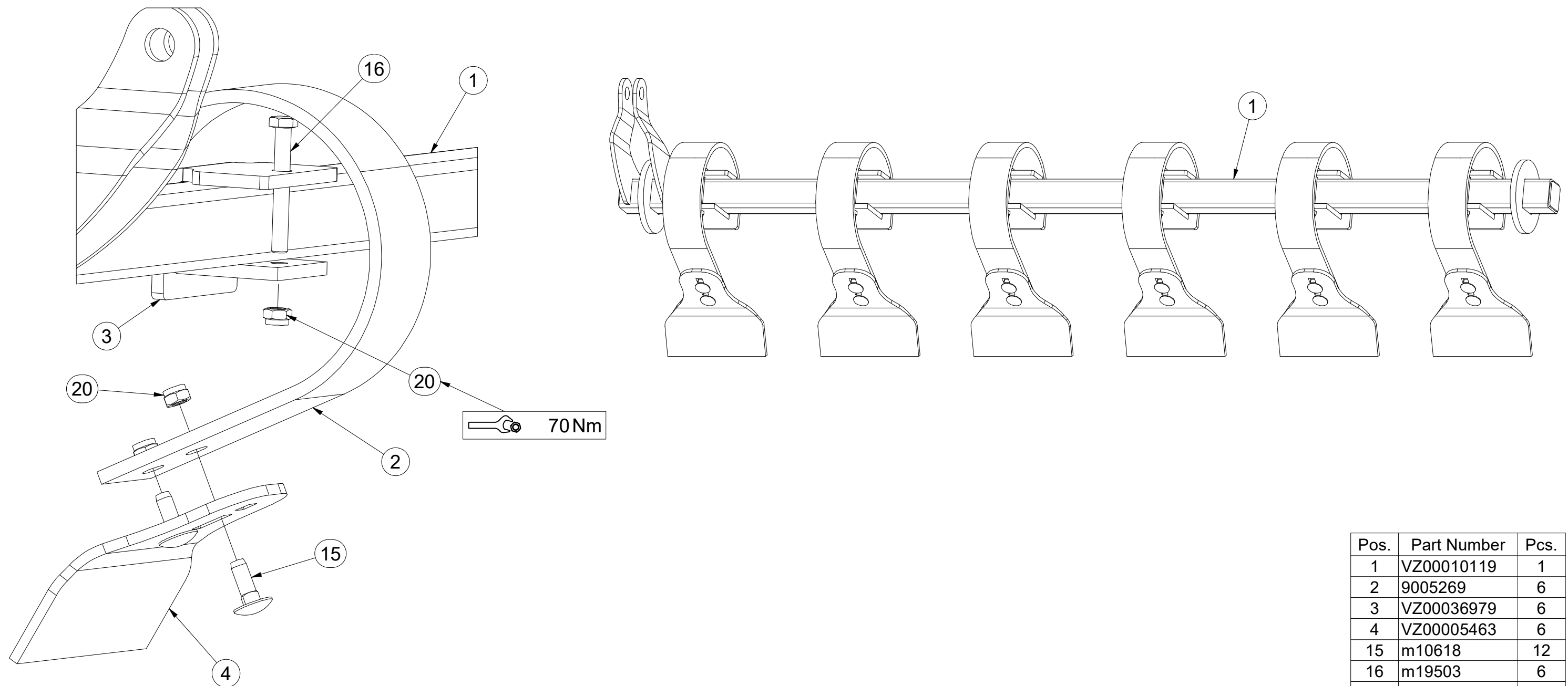
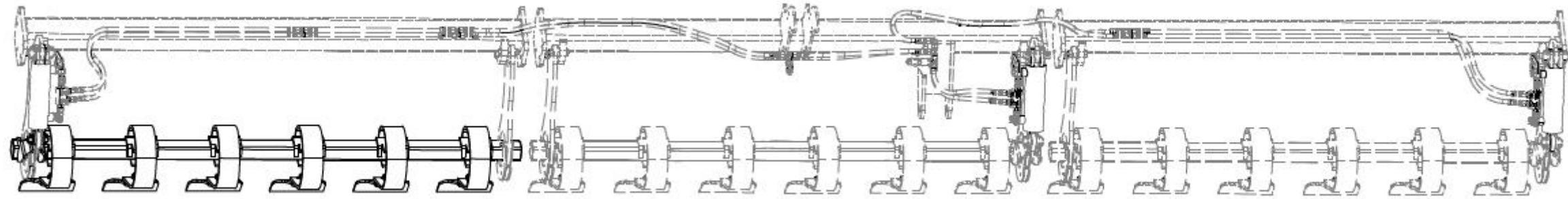

Pos.	Part Number	Pcs.
1	VZ00010119	1
2	9005269	6
3	VZ00036979	6
4	VZ00005463	6
15	m10618	12
16	m19503	6
20	m04301	18

Ⓒ PŘEDNÍ SMYK

Ⓓ VORDERE ACKERSCHLEIFE

Ⓕ NIVELEUR AVANT

Ⓒ FRONT LEVELLER

Ⓓ ПЕРЕДНЯЯ БОРОНА

Ⓕ PRZEDNIA WŁÓKA



VZ00005418

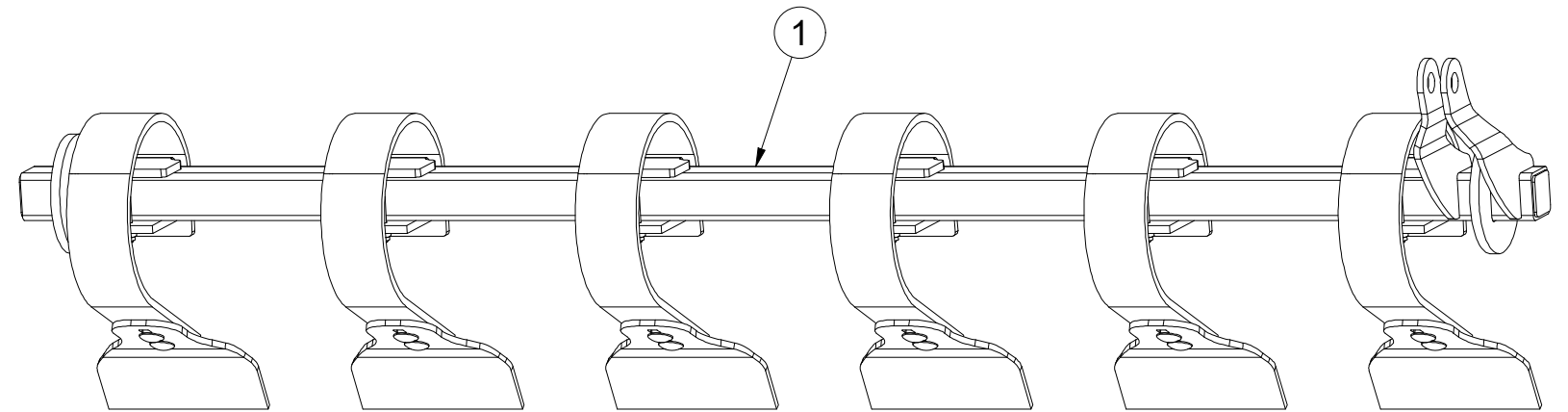
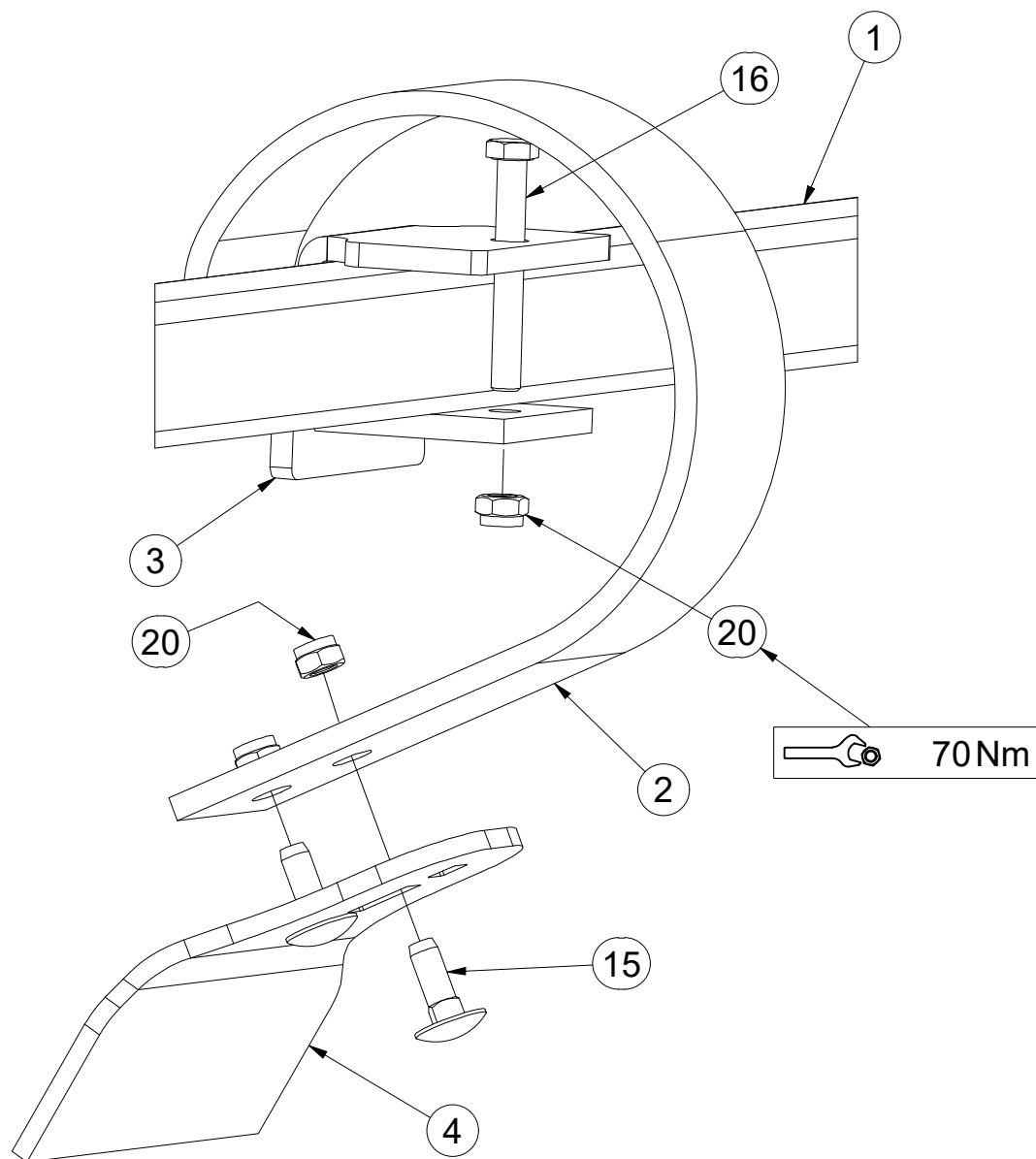
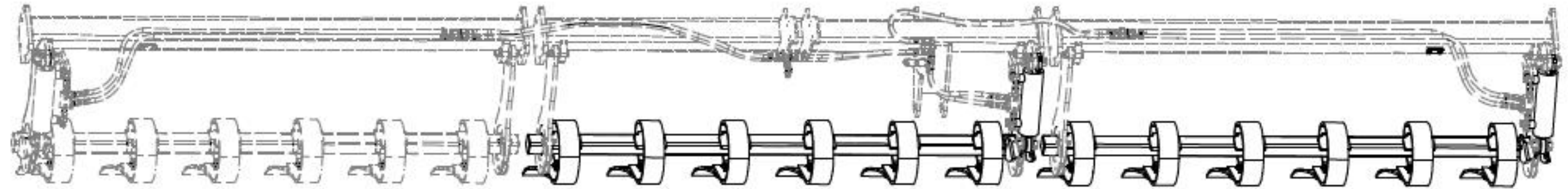

Pos.	Part Number	Pcs.
1	VZ00005233	1
2	9005269	6
3	VZ00036979	6
4	VZ00005463	6
15	m10618	12
16	m19503	6
20	m04301	18

ⒸZ HYDRAULICKÉ OVLÁDÁNÍ PŘEDNÍCH SMYKŮ

Ⓓ HYDRAULISCHE EINSTELLUNG DER VORDEREN ACKERSCHLEIFE

Ⓕ COMMANDE HYDRAULIQUE DES NIVELEURS AVANT

ⒸB HYDRAULIC CONTROL OF FRONT LEVELLERS

ⒸR ГИДРАВЛИЧЕСКОЕ УПРАВЛЕНИЕ ПЕРЕДНИХ БОРОН

ⒸL HYDRAULICZNE STEROWANIE PRZEDNIMI WŁÓKAMI

Farmet

VZ00037573

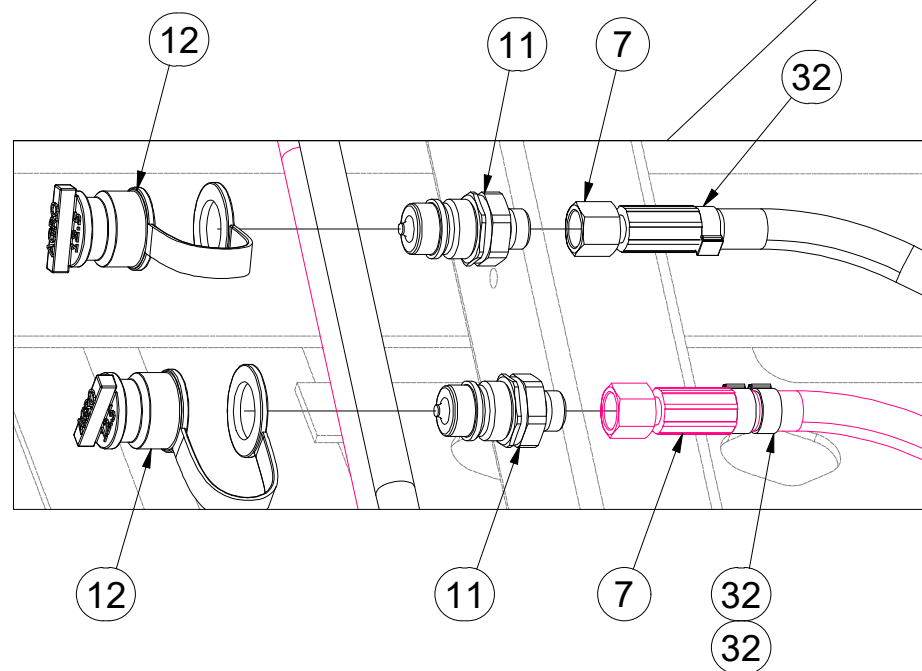
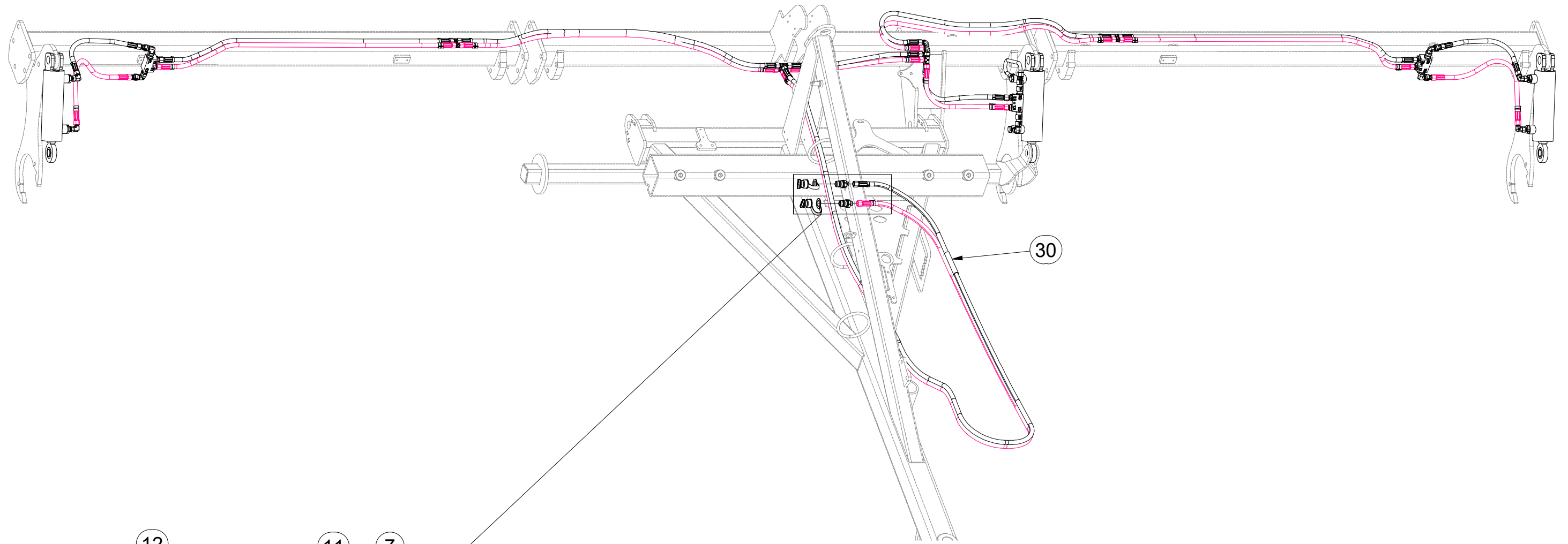

Pos.	Part Number	Pcs.
7	m04087	2
11	m03849	2
12	m03743	2
30	m11183	1
32	m11253	48

ⒸZ HYDRAULICKÉ OVLÁDÁNÍ PŘEDNÍCH SMYKŮ

Ⓓ HYDRAULISCHE EINSTELLUNG DER VORDEREN ACKERSCHLEIFE

Ⓕ COMMANDE HYDRAULIQUE DES NIVELEURS AVANT

ⒸB HYDRAULIC CONTROL OF FRONT LEVELLERS

ⒸU ГИДРАВЛИЧЕСКОЕ УПРАВЛЕНИЕ ПЕРЕДНИХ БОРОН

ⒸL HYDRAULICZNE STEROWANIE PRZEDNIMI WŁÓKAMI

Farmet

VZ00037573

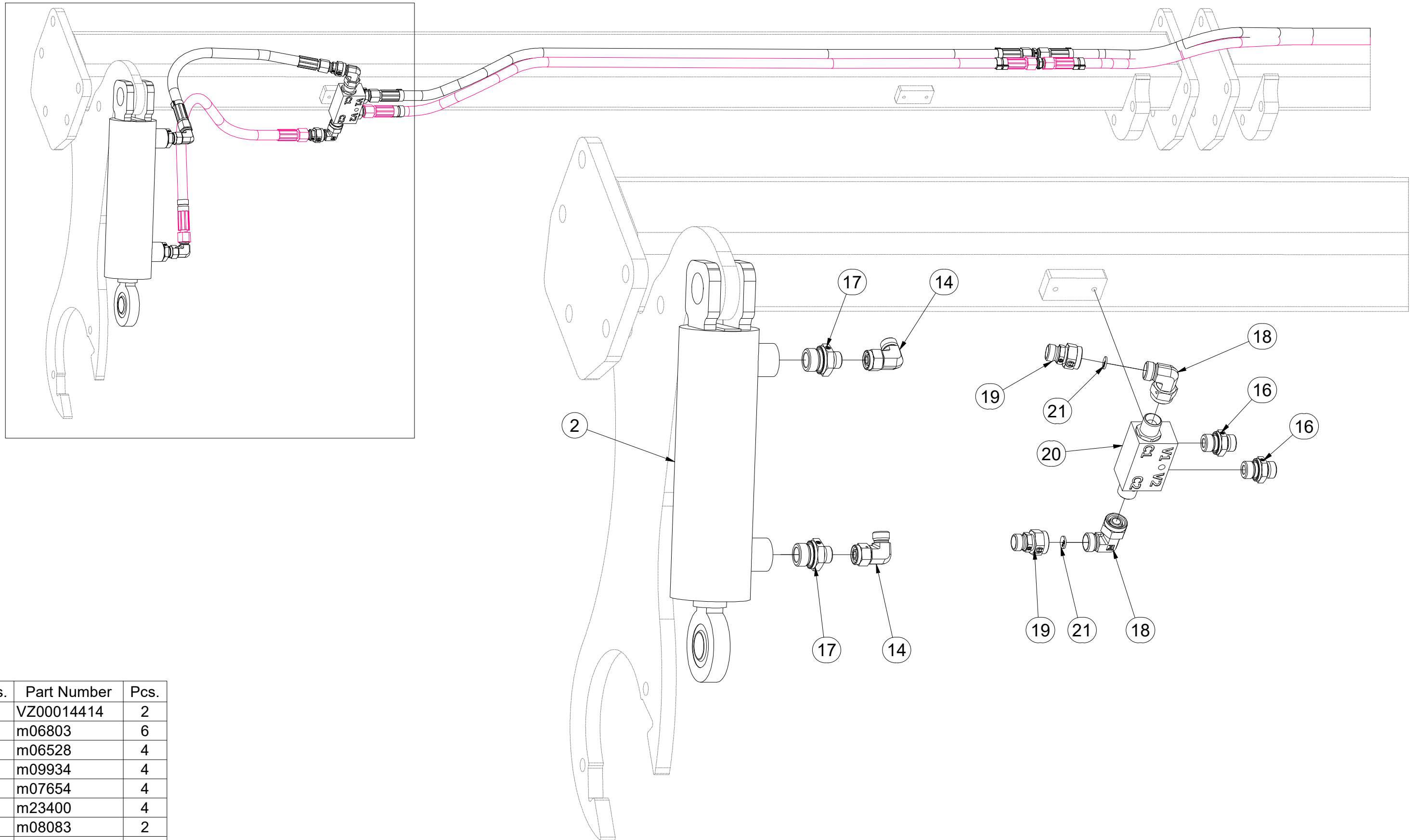

Pos.	Part Number	Pcs.
2	VZ00014414	2
14	m06803	6
16	m06528	4
17	m09934	4
18	m07654	4
19	m23400	4
20	m08083	2
21	m10649	4

ⒸZ HYDRAULICKÉ OVLÁDÁNÍ PŘEDNÍCH SMYKŮ

Ⓓ HYDRAULISCHE EINSTELLUNG DER VORDEREN ACKERSCHLEIFE

Ⓕ COMMANDE HYDRAULIQUE DES NIVELEURS AVANT

ⒸB HYDRAULIC CONTROL OF FRONT LEVELLERS

ⒸR ГИДРАВЛИЧЕСКОЕ УПРАВЛЕНИЕ ПЕРЕДНИХ БОРОН

ⒸL HYDRAULICZNE STEROWANIE PRZEDNIMI WŁÓKAMI



VZ00037573

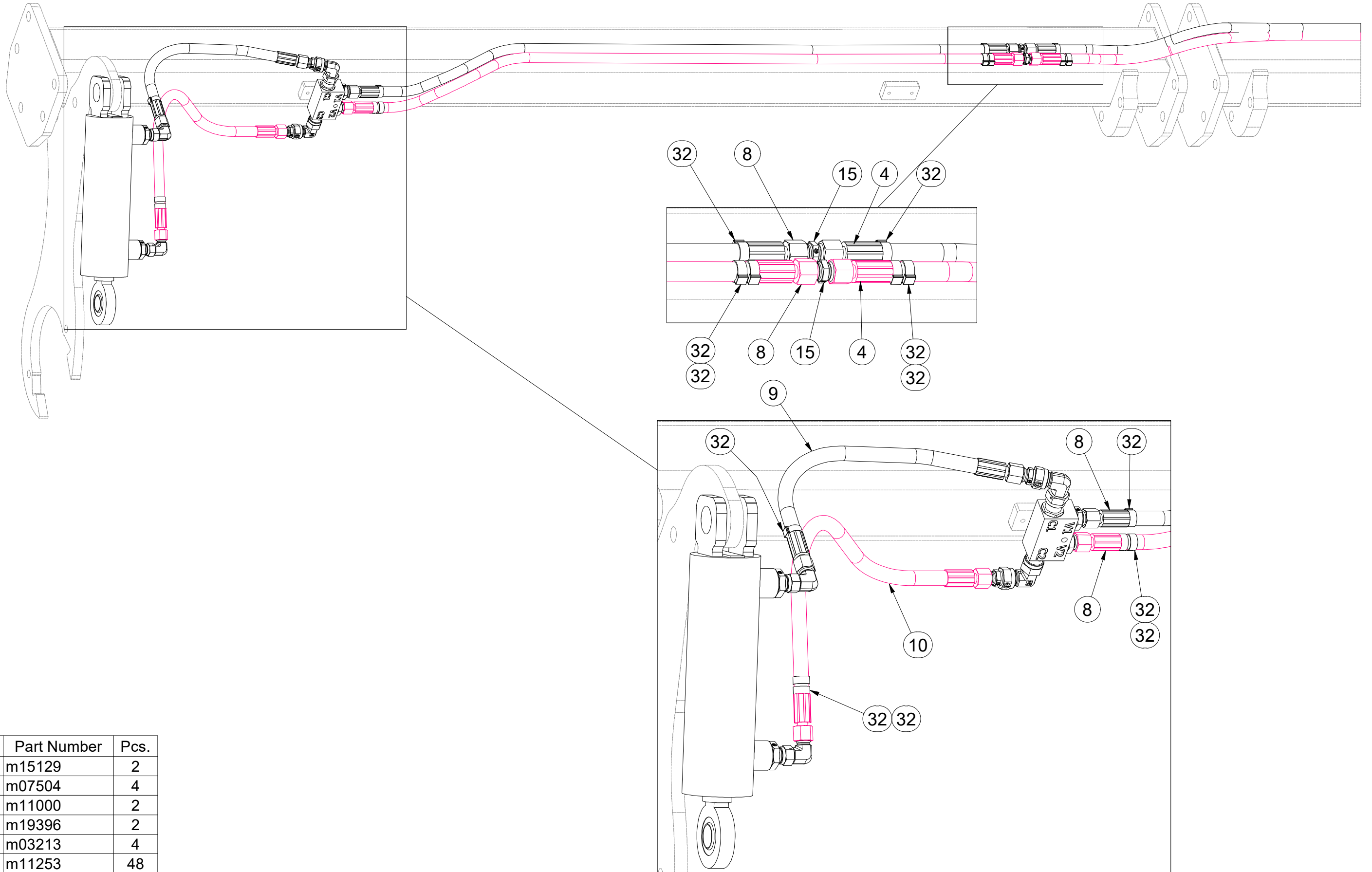

Pos.	Part Number	Pcs.
4	m15129	2
8	m07504	4
9	m11000	2
10	m19396	2
15	m03213	4
32	m11253	48

ⒸZ HYDRAULICKÉ OVLÁDÁNÍ PŘEDNÍCH SMYKŮ

Ⓓ HYDRAULISCHE EINSTELLUNG DER VORDEREN ACKERSCHLEIFE

Ⓕ COMMANDE HYDRAULIQUE DES NIVELEURS AVANT

ⒸB HYDRAULIC CONTROL OF FRONT LEVELLERS

ⒸU ГИДРАВЛИЧЕСКОЕ УПРАВЛЕНИЕ ПЕРЕДНИХ БОРОН

ⒸL HYDRAULICZNE STEROWANIE PRZEDNIAMI WŁÓKAMI



VZ00037573

Pos.	Part Number	Pcs.	Pos.	Part Number	Pcs.
1	VZ00013485	1	6	m17441	2
3	m05210	2	7	m04087	2
4	m15129	2	13	m03889	4
5	m09628	2	14	m06803	6
			32	m11253	48

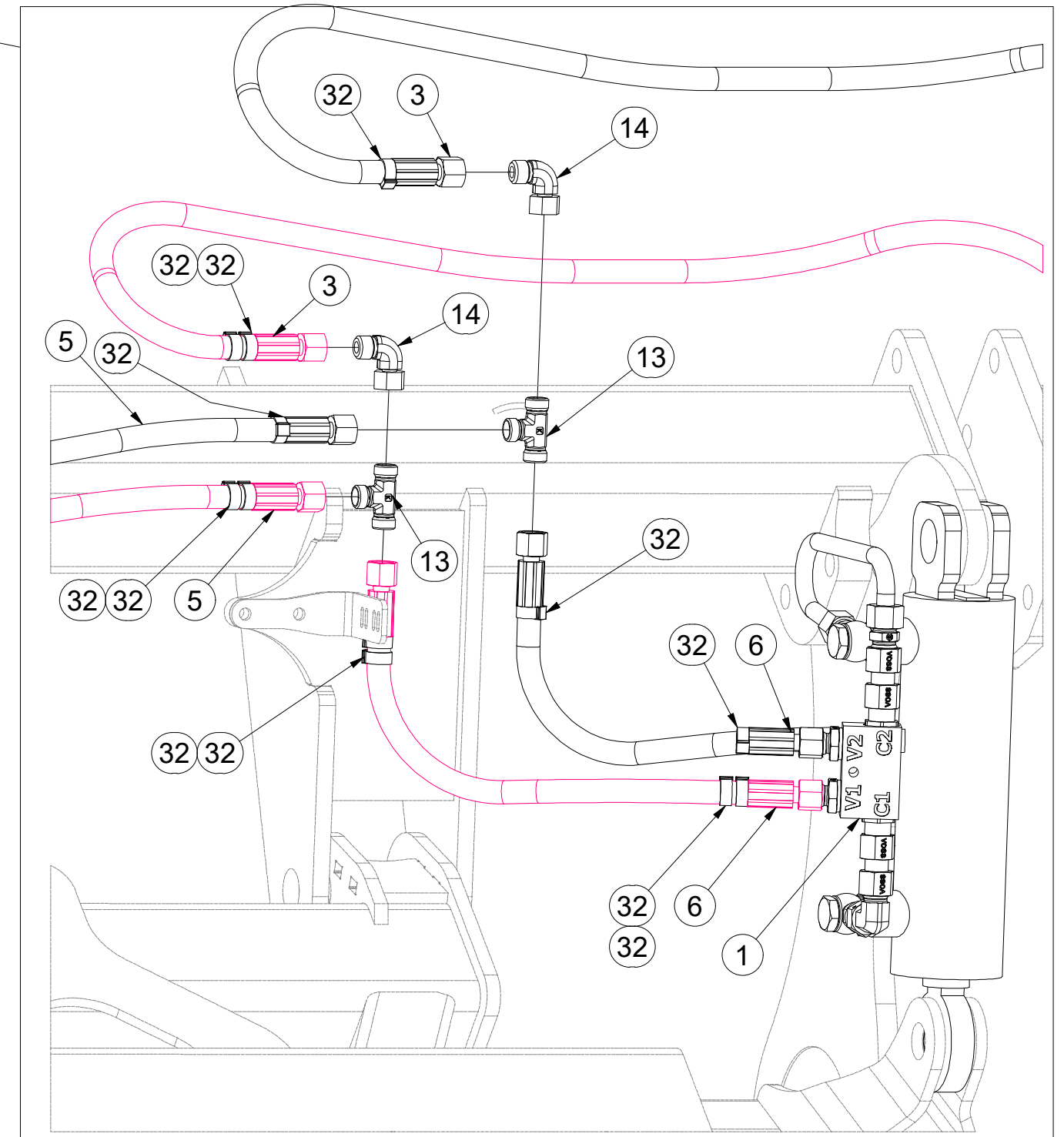
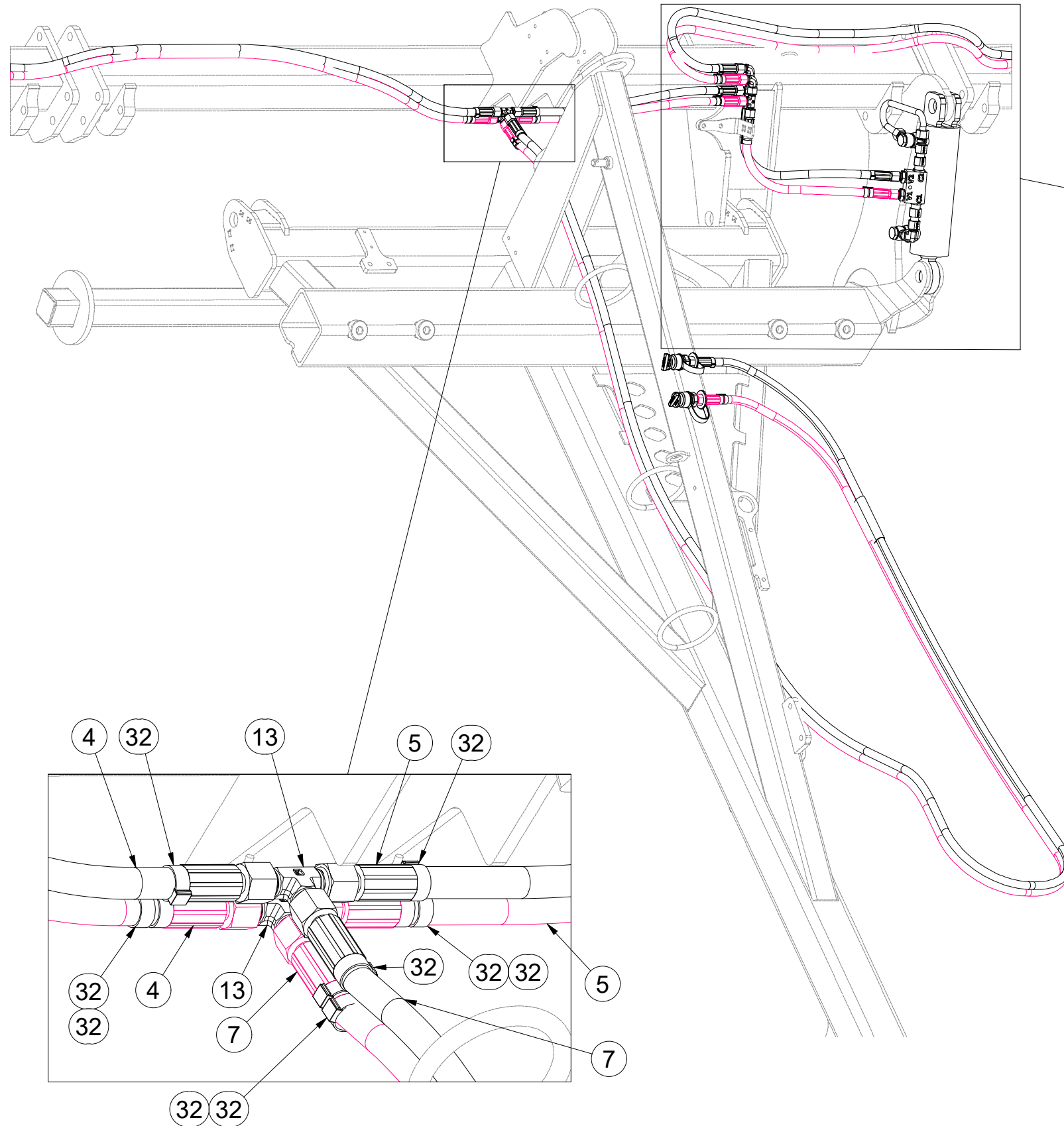

ⒸZ HYDRAULICKÉ OVLÁDÁNÍ PŘEDNÍCH SMYKŮ

Ⓓ HYDRAULISCHE EINSTELLUNG DER VORDEREN ACKERSCHLEIFE

Ⓕ COMMANDE HYDRAULIQUE DES NIVELEURS AVANT

ⒸB HYDRAULIC CONTROL OF FRONT LEVELLERS

Ⓔ ГИДРАВЛИЧЕСКОЕ УПРАВЛЕНИЕ ПЕРЕДНИХ БОРОН

Ⓖ HYDRAULICZNE STEROWANIE PRZEDNIMI WŁÓKAMI

Farmet

VZ00037573

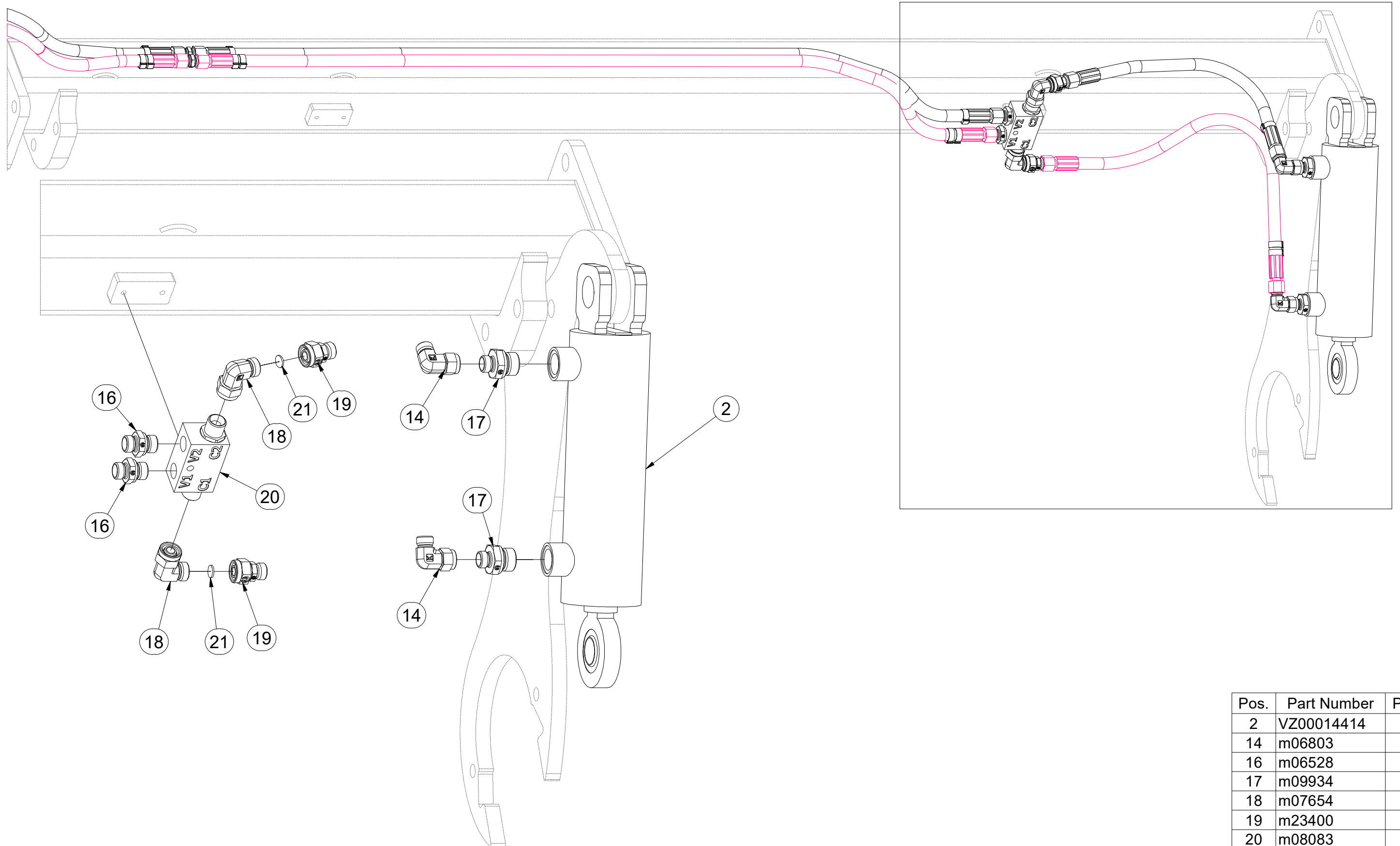

Pos.	Part Number	Pcs.
2	VZ00014414	2
14	m06803	6
16	m06528	4
17	m09934	4
18	m07654	4
19	m23400	4
20	m08083	2
21	m10649	4

ⒸZ HYDRAULICKÉ OVLÁDÁNÍ PŘEDNÍCH SMYKŮ

Ⓓ HYDRAULISCHE EINSTELLUNG DER VORDEREN ACKERSCHLEIFE

Ⓕ COMMANDE HYDRAULIQUE DES NIVELEURS AVANT

ⒼB HYDRAULIC CONTROL OF FRONT LEVELLERS

Ⓔ RU ГИДРАВЛИЧЕСКОЕ УПРАВЛЕНИЕ ПЕРЕДНИХ БОРОН

Ⓗ PL HYDRAULICZNE STEROWANIE PRZEDNIMI WŁÓKAMI



VZ00037573

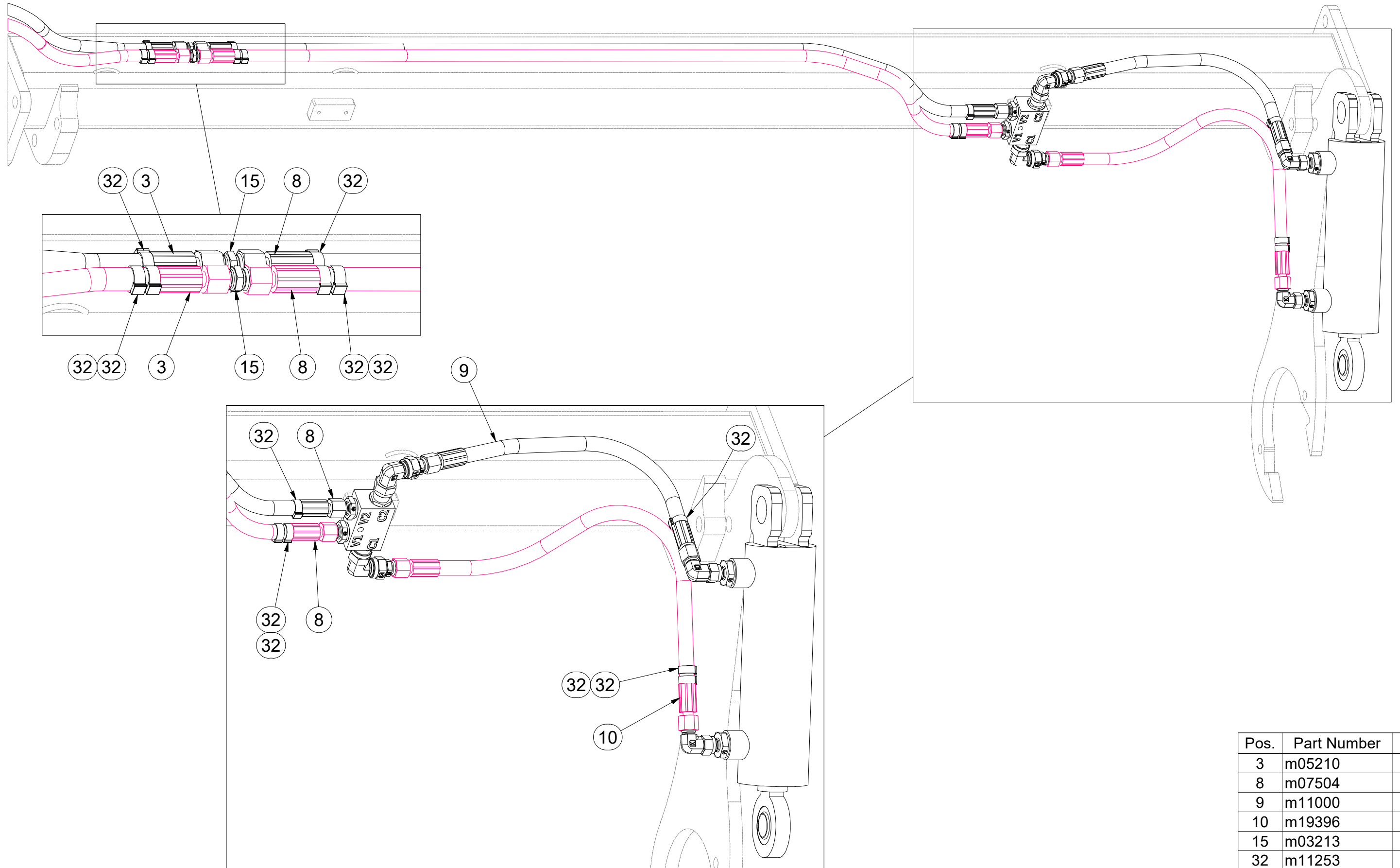

Pos.	Part Number	Pcs.
3	m05210	2
8	m07504	4
9	m11000	2
10	m19396	2
15	m03213	4
32	m11253	48

ⒸZ HYDRAULICKÉ OVLÁDÁNÍ PŘEDNÍCH SMYKŮ

Ⓓ HYDRAULISCHE EINSTELLUNG DER VORDEREN ACKERSCHLEIFE

Ⓕ COMMANDE HYDRAULIQUE DES NIVELEURS AVANT

ⒸB HYDRAULIC CONTROL OF FRONT LEVELLERS

Ⓔ ГИДРАВЛИЧЕСКОЕ УПРАВЛЕНИЕ ПЕРЕДНИХ БОРОН

Ⓗ HYDRAULICZNE STEROWANIE PRZEDNIMI WŁÓKAMI

Farmet

VZ00037573

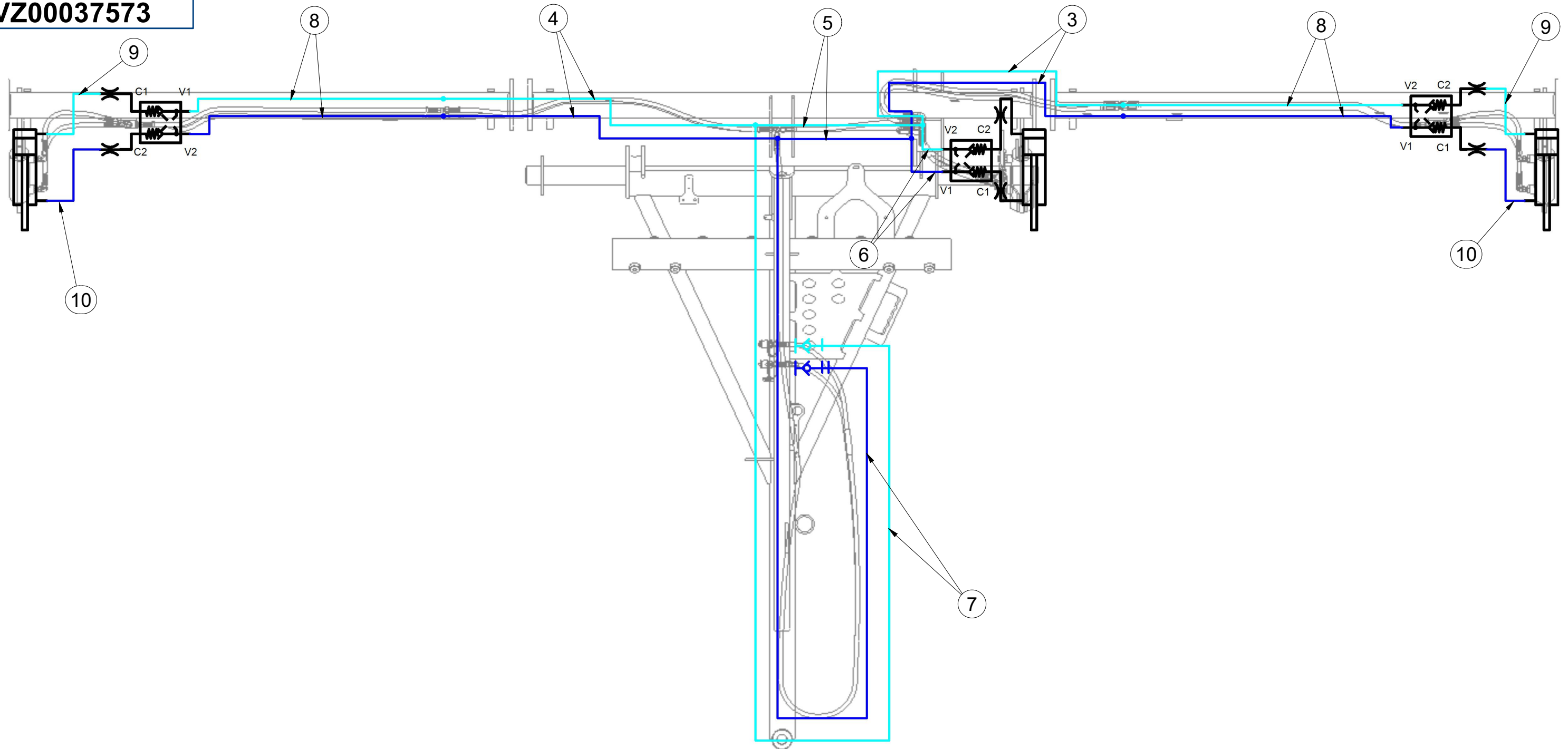

Pos.	Part Number	Pcs.
3	m05210	2
4	m15129	2
5	m09628	2
6	m17441	2
7	m04087	2
8	m07504	4
9	m11000	2
10	m19396	2

Ⓒ PÍSTNICE 63/32-160

Ⓓ KOLBENSTANGE 63/32-160

Ⓕ TIGE DE PISTON 63/32-160

Ⓖ PISTON ROD 63/32-160

Ⓔ ЦИЛИНДР 63/32-160

Ⓟ TRZPIEŃ TŁOKA 63/32-160



VZ00013485

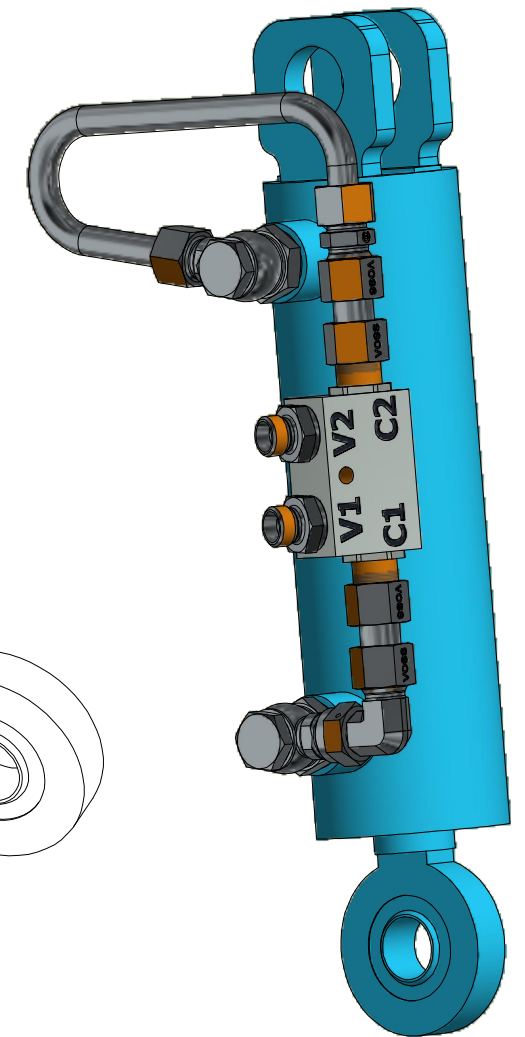
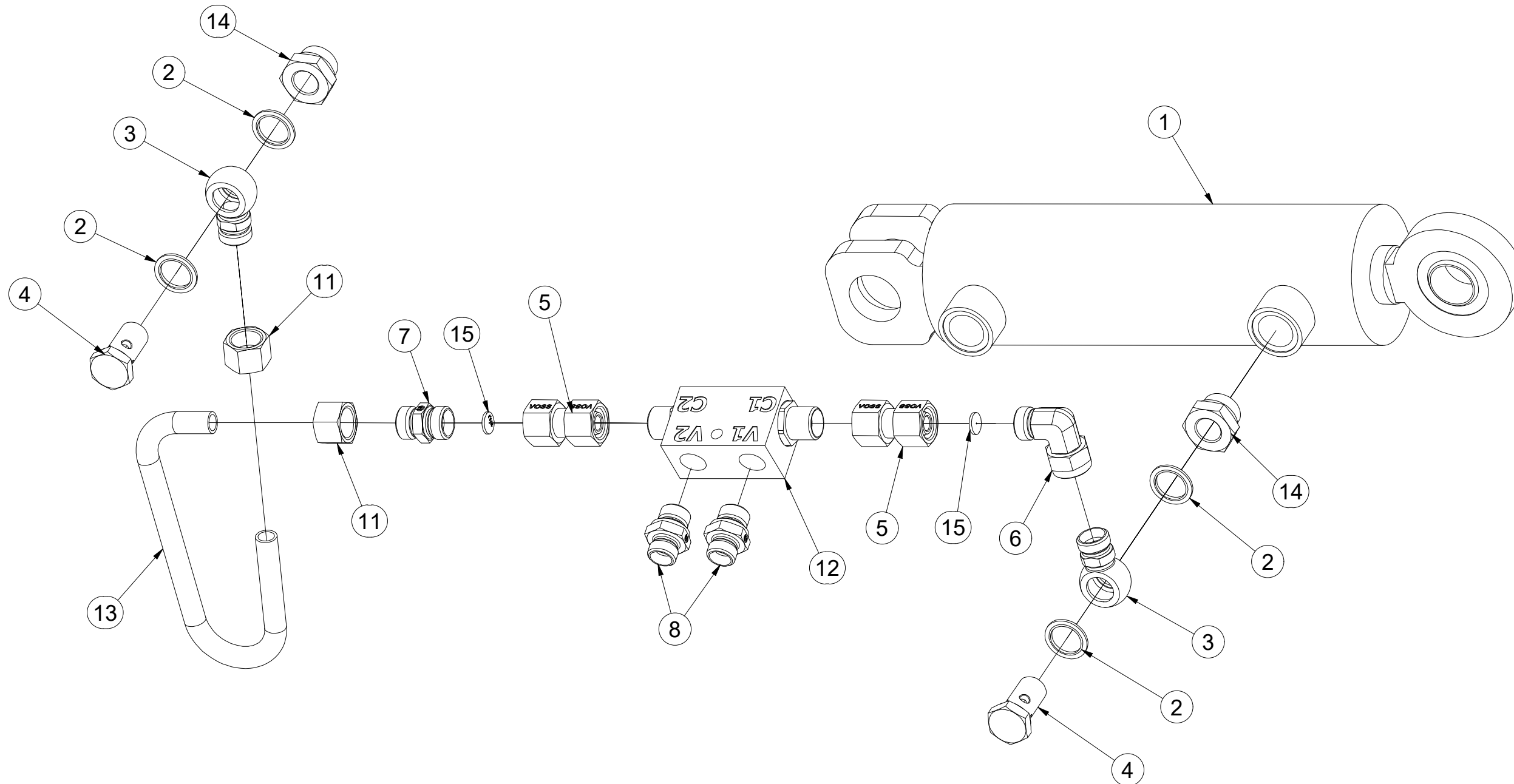

Pos.	Part Number	Pcs.
1	VZ00014414	1
2	m12442	4
3	m08461	2
4	m08460	2
5	m22306	2
6	m07654	1
7	m16910	1
8	m06528	2
11	m17321	2
12	m08083	1
13	VZ00022659	1
14	m08462	2
15	m10649	2

CZ SADA PŘEDNÍCH VÁLCŮ
 D SATZ VORDERE WALZEN
 F KIT DE ROULEAUX AVANT

GB SET OF FRONT ROLLERS
 RU КОМПЛЕКТ ПЕРЕДНИХ КАТКОВ
 PL ZESTAW PRZEDNICH WAŁÓW



VZ00039823

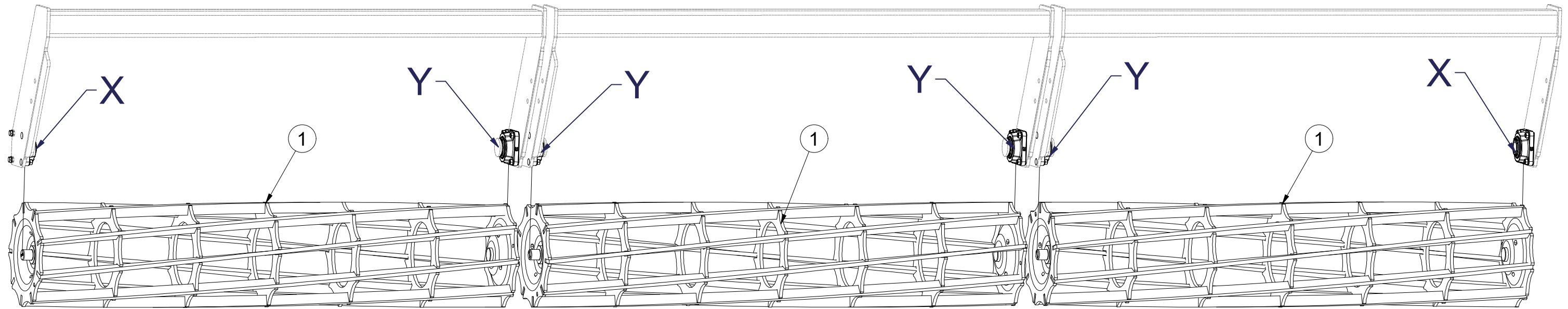

X

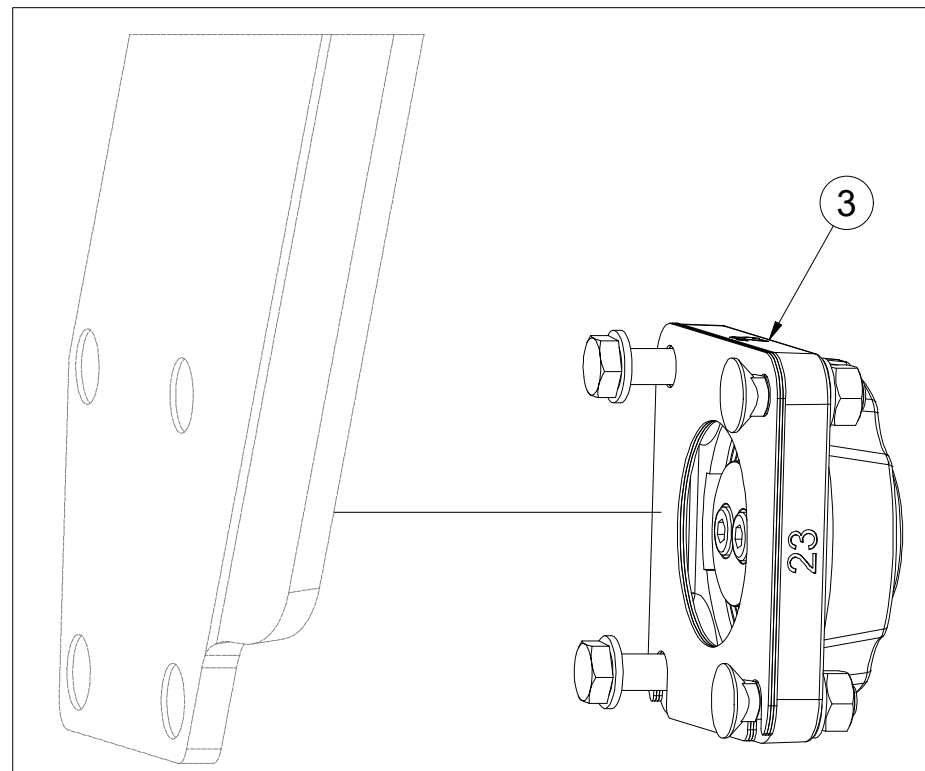

Y

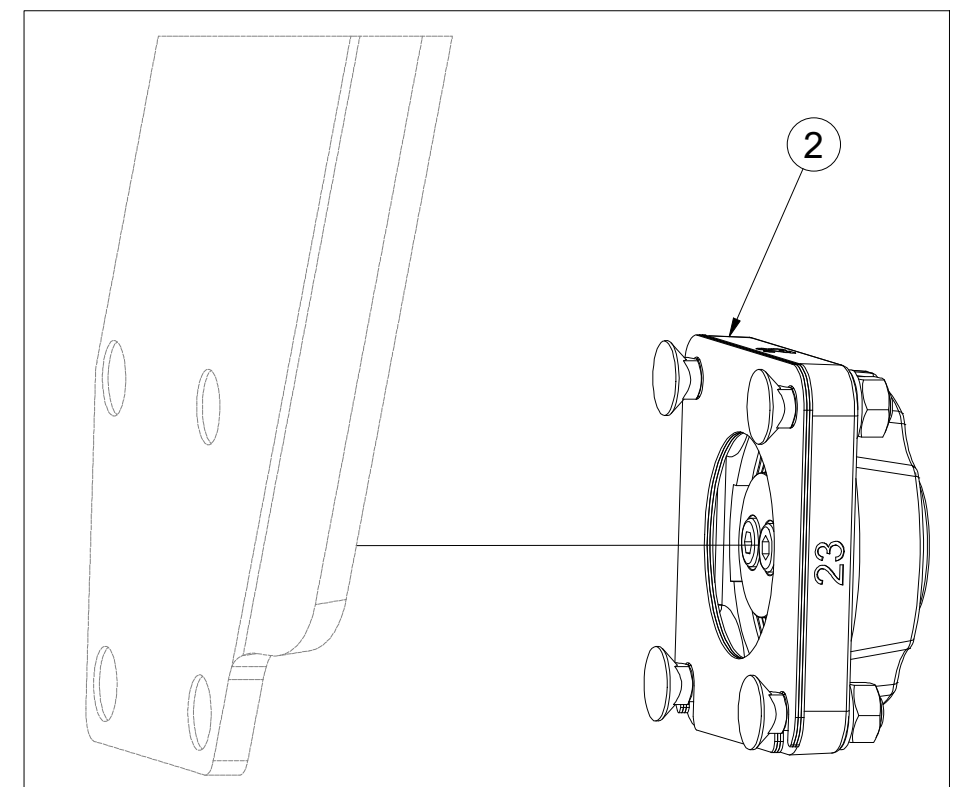

Pos.	Part Number	Pcs.
1	VZ00037622	3
3	VZ00039819	2
2	VZ00038060	4

CZ SADA LOŽISEK
 D SATZ LAGER
 F KIT DE ROULEMENTS

GB SET OF BEARINGS
 RU КОМПЛЕКТ ПОДШИПНИКОВ
 PL ZESTAW ŁOŻYSK



VZ00038060

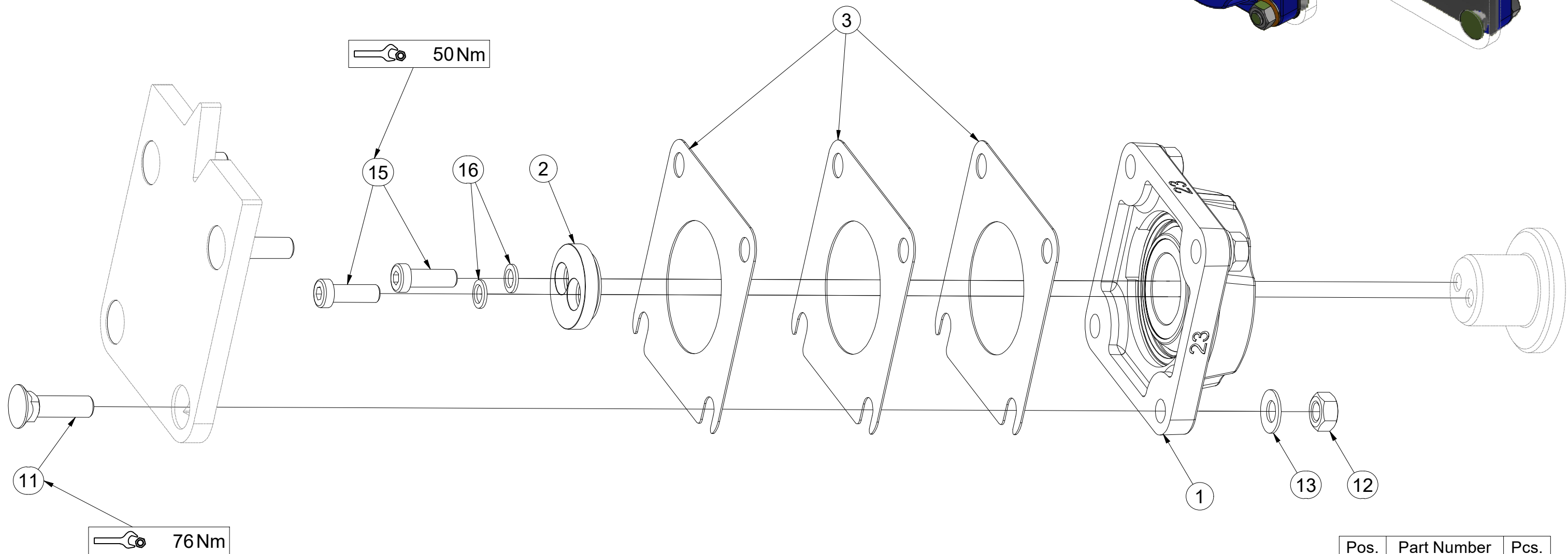
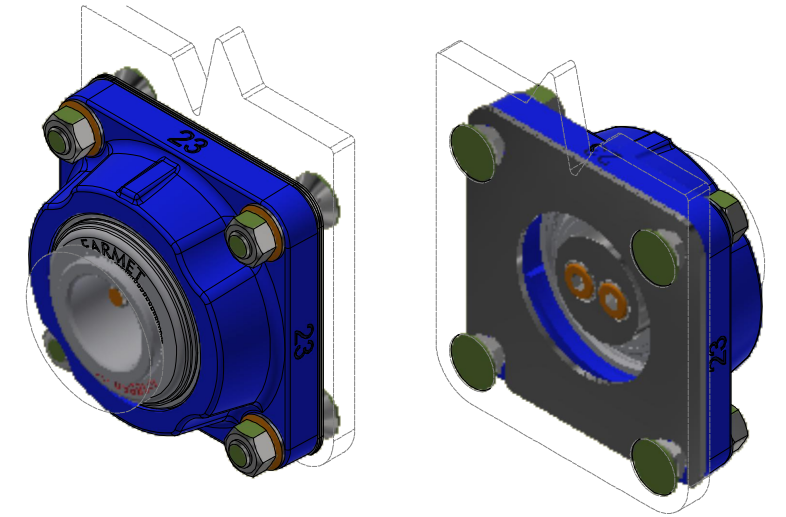

Pos.	Part Number	Pcs.
1	m18650-23	1
2	VZ00038211	1
3	4016809	3
11	m03519	4
12	m01305	4
13	m17545	4
15	m24320	2
16	m24356	2

CZ SADA LOŽISEK
 D SATZ LAGER
 F KIT DE ROULEMENTS

GB SET OF BEARINGS
 RU КОМПЛЕКТ ПОДШИПНИКОВ
 PL ZESTAW ŁOŻYSK



VZ00039819

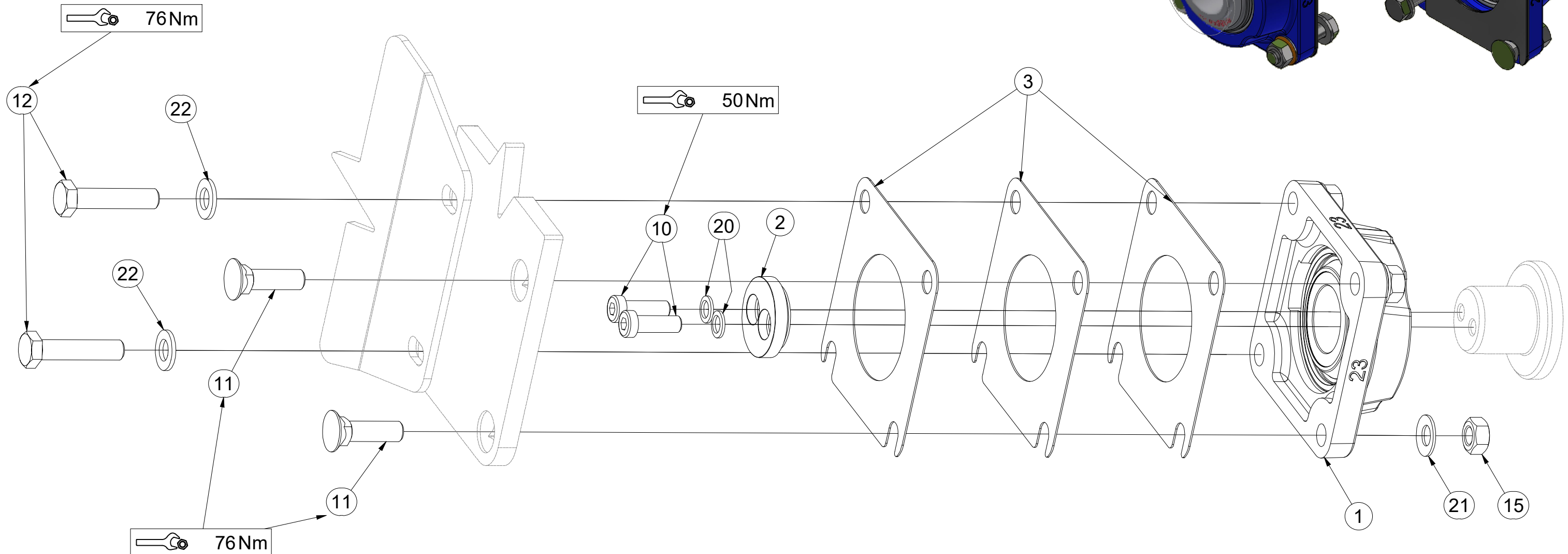
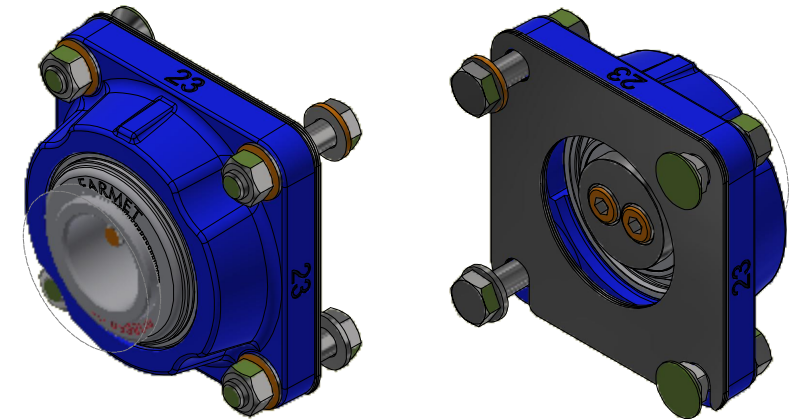

Pos.	Part Number	Pcs.
1	m18650-23	1
2	VZ00038211	1
3	4016809	3
10	m24320	2
11	m03519	2
12	m04412	2
15	m01305	4
20	m24356	2
21	m17545	4
22	m17741	2

VZ00038564

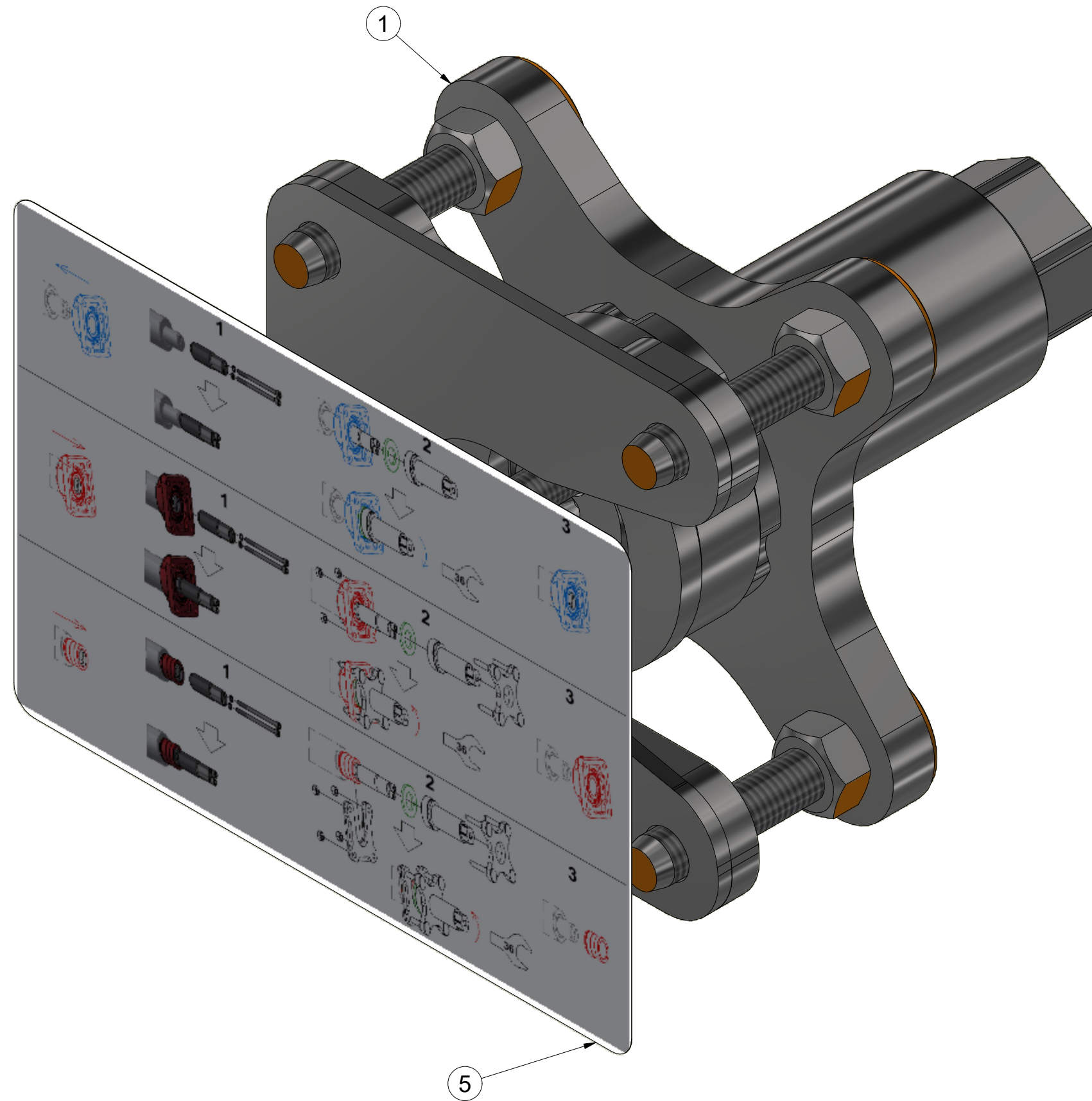

Pos.	Part Number	Pcs.
1	VZ00040530	1
5	m24596	1

VZ00040530

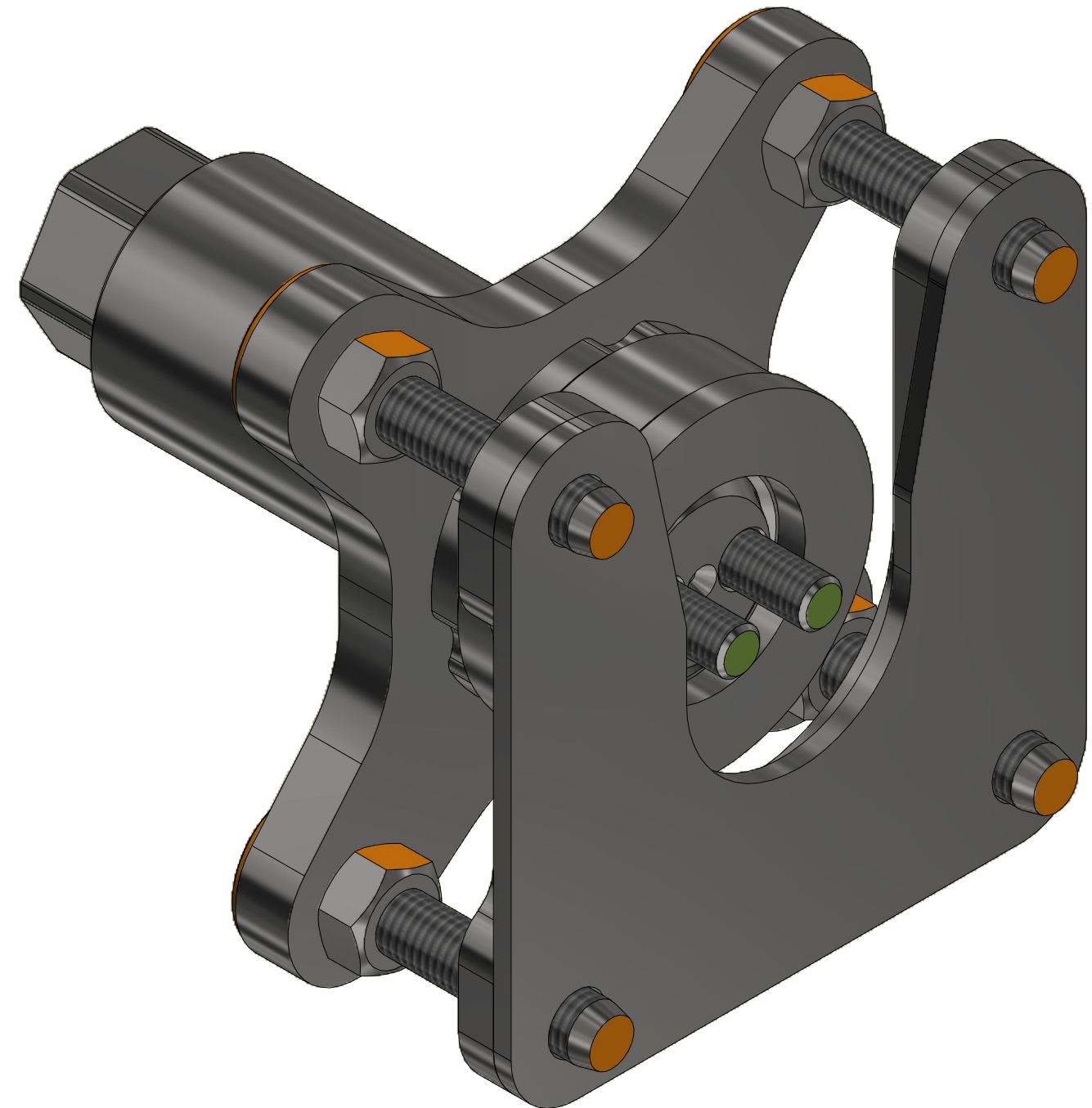
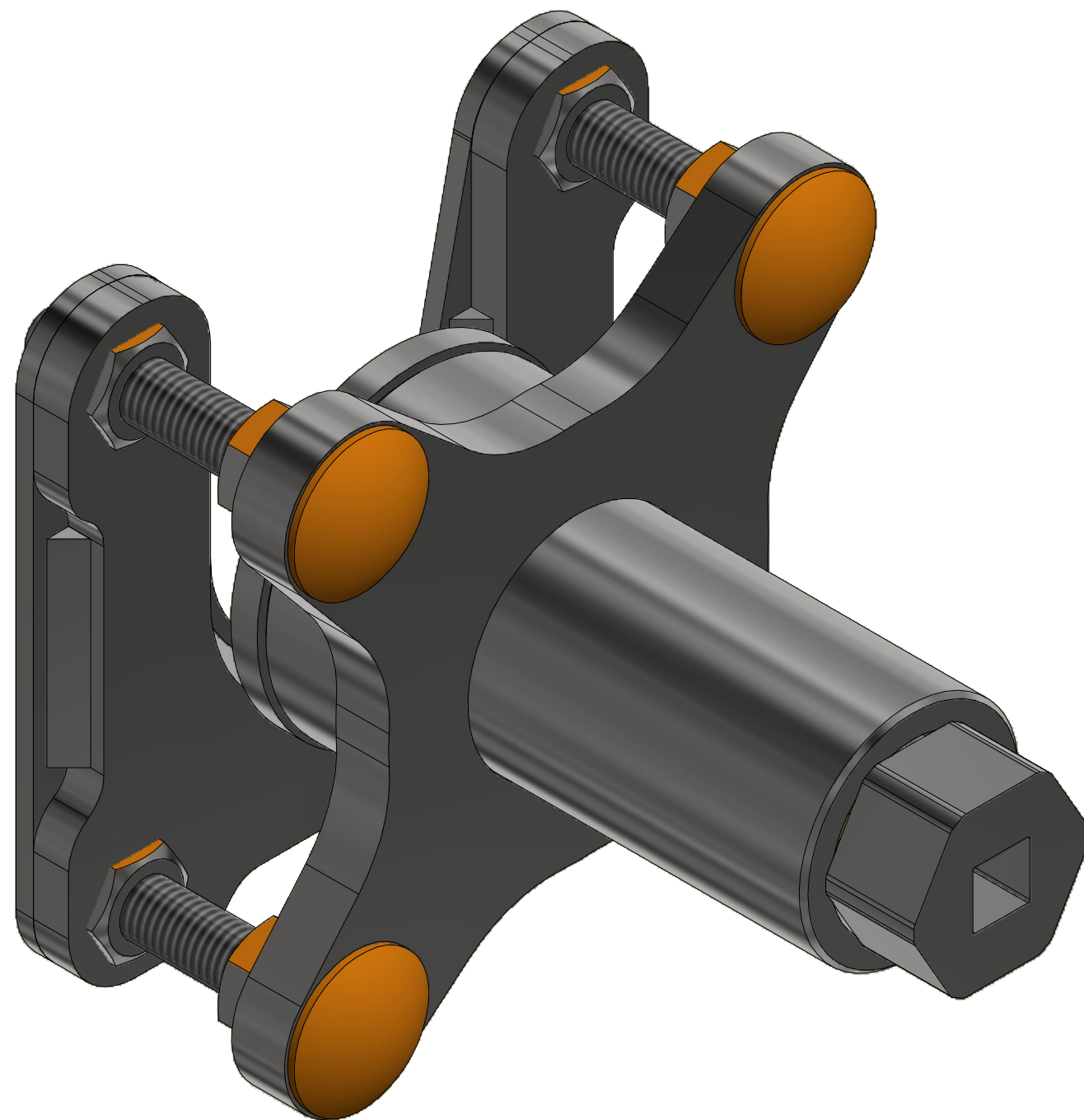

VZ00040530

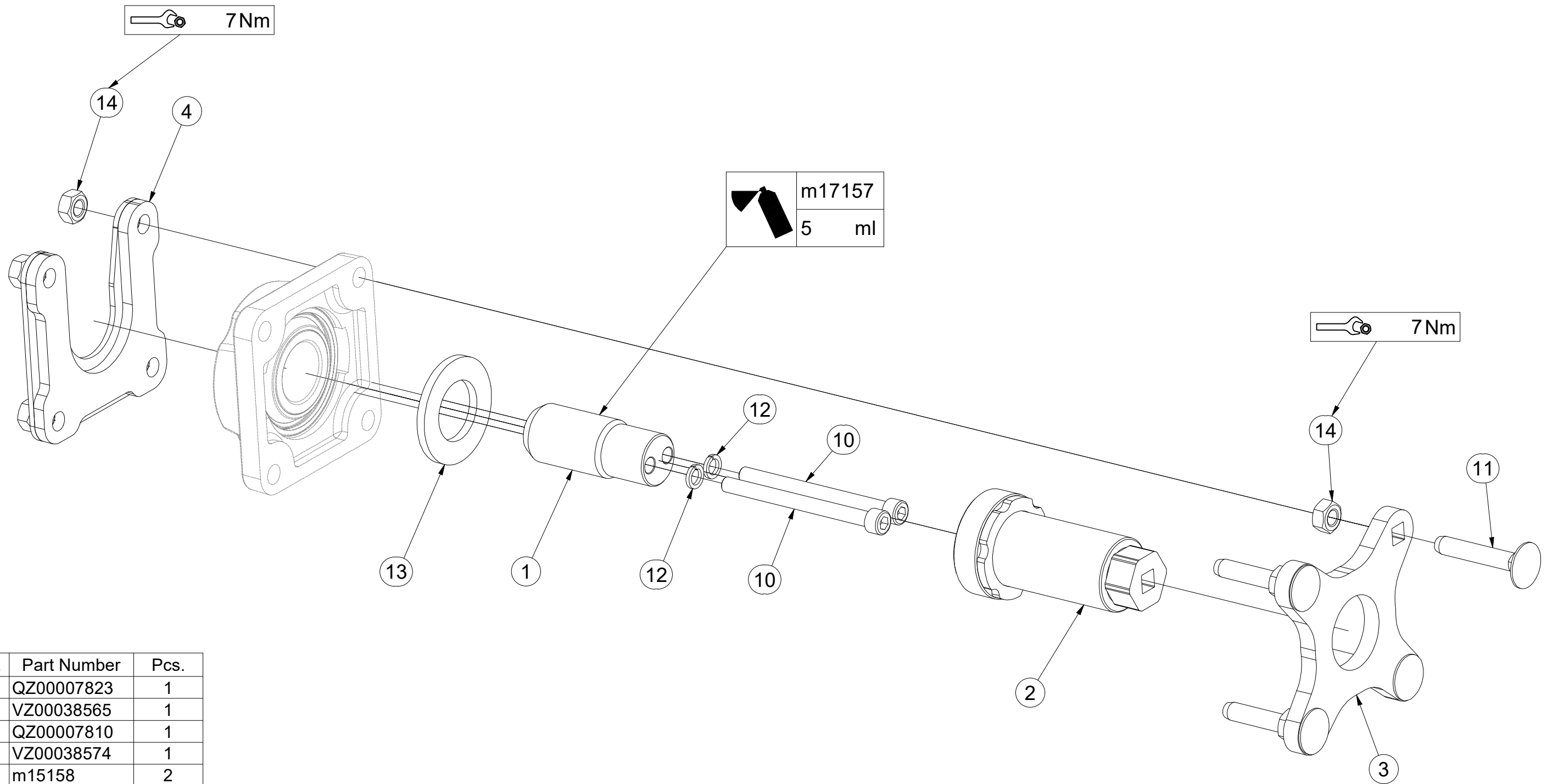

Pos.	Part Number	Pcs.
1	QZ00007823	1
2	VZ00038565	1
3	QZ00007810	1
4	VZ00038574	1
10	m15158	2
11	m17684	4
12	m01208	2
13	m03636	1
14	m10439	8
20	m17157	5,00 ml

Ⓒ SADA OVLÁDÁNÍ RADLIC

Ⓓ STEUERSATZ PFLUGSCHAREN

Ⓕ KIT DE COMMANDE DES SOCS

Ⓖ SET OF PLOUGHSHARE CONTROL

Ⓡ КОМПЛЕКТ УПРАВЛЕНИЯ ЛАП

Ⓟ ZESTAW STEROWANIA RADLICAMI



VZ00043008

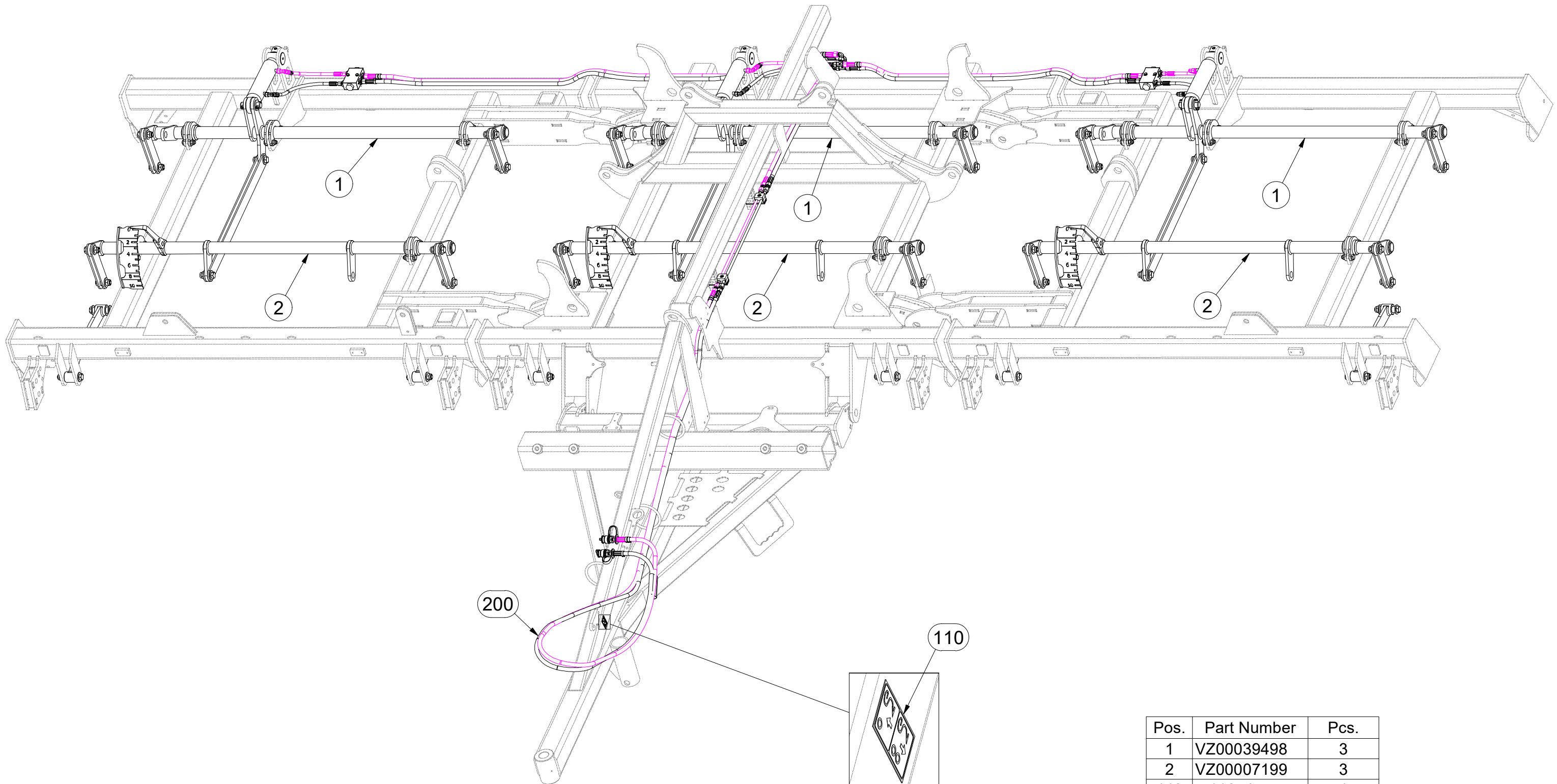

Pos.	Part Number	Pcs.
1	VZ00039498	3
2	VZ00007199	3
110	m11654	1
121	m05566	35
200	m22954	1,500 l

Ⓒ SADA OVLÁDÁNÍ RADLIC

Ⓓ STEUERSATZ PFLUGSCHAREN

Ⓕ KIT DE COMMANDE DES SOCS

Ⓖ SET OF PLOUGHSHARE CONTROL

Ⓔ КОМПЛЕКТ УПРАВЛЕНИЯ ЛАП

Ⓗ ZESTAW STEROWANIA RADLICAMI



VZ00043008

Pos.	Part Number	Pcs.	Pos.	Part Number	Pcs.
1	VZ00039498	3	71	m03926	6
2	VZ00007199	3	72	m06077	24
6	4022084	6	79	m12431	6
7	VZ00039490	3	81	m04301	30
21	4005332	21	84	m05560	6
22	VZ00007253	3	115	m10130	12

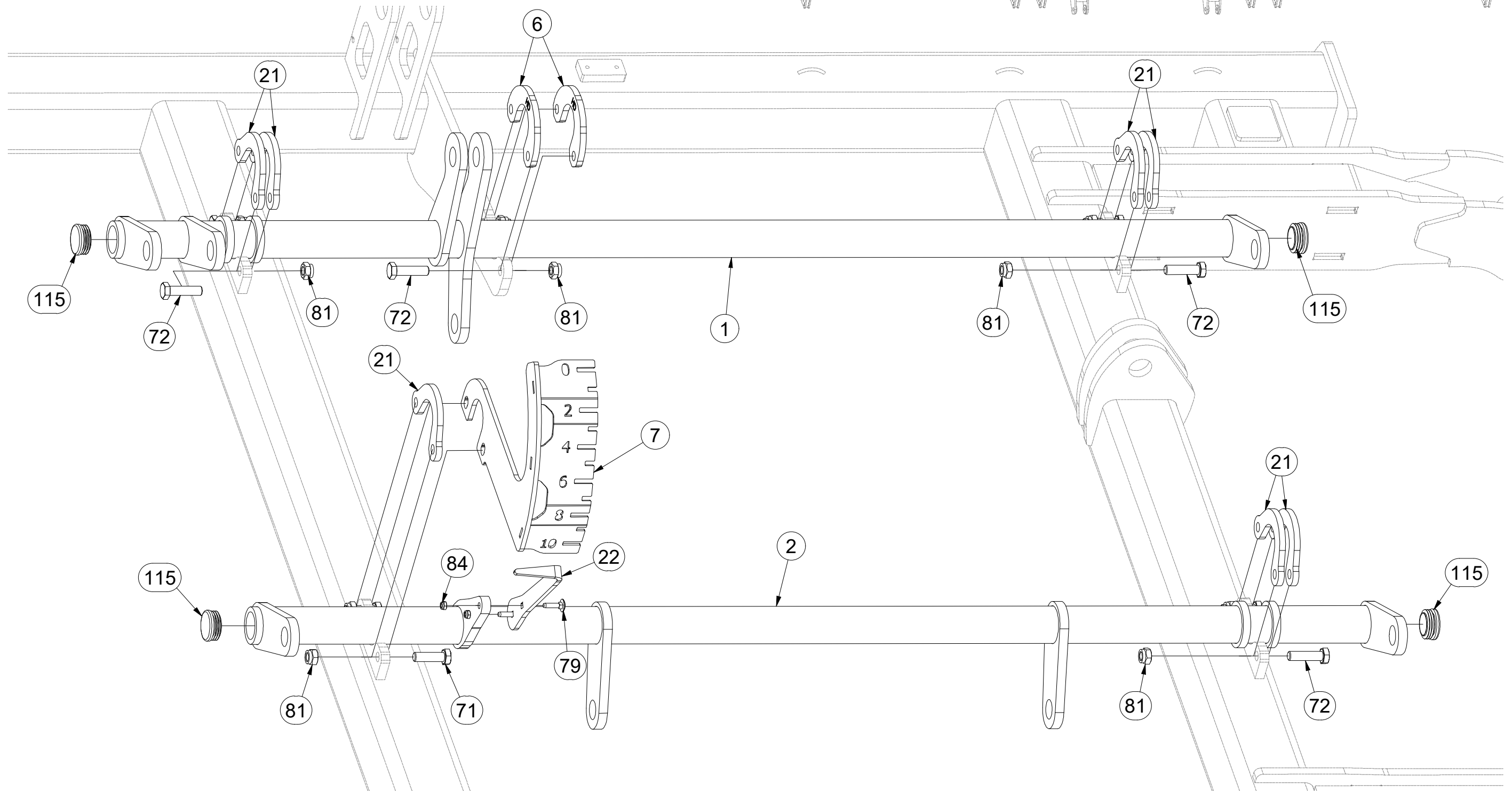
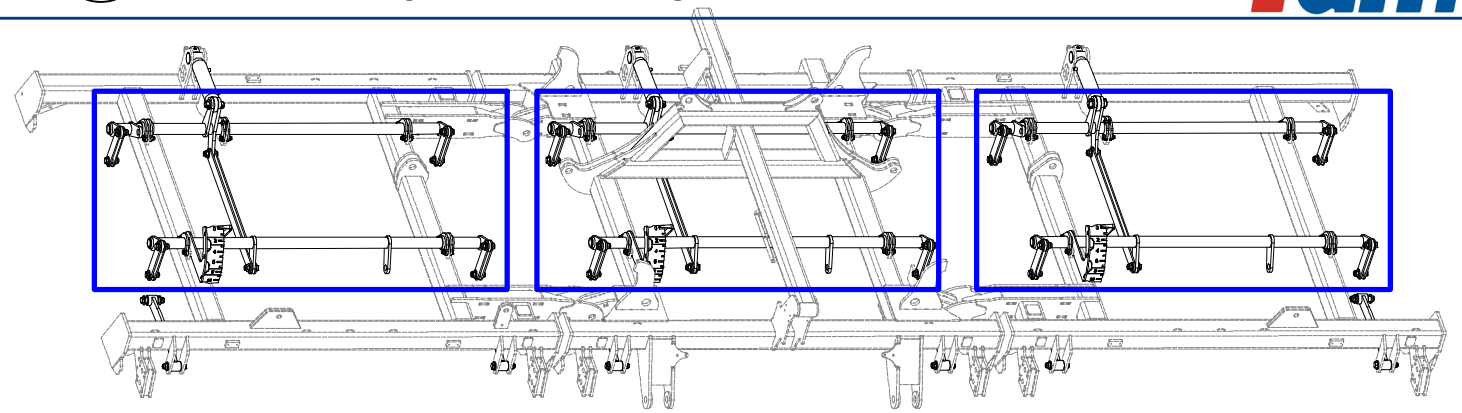

Ⓒ SADA OVLÁDÁNÍ RADLIC

Ⓓ STEUERSATZ PFLUGSCHAREN

Ⓕ KIT DE COMMANDE DES SOCS

Ⓖ SET OF PLOUGHSHARE CONTROL

Ⓡ КОМПЛЕКТ УПРАВЛЕНИЯ ЛАП

Ⓟ ZESTAW STEROWANIA RADLICAMI



VZ00043008

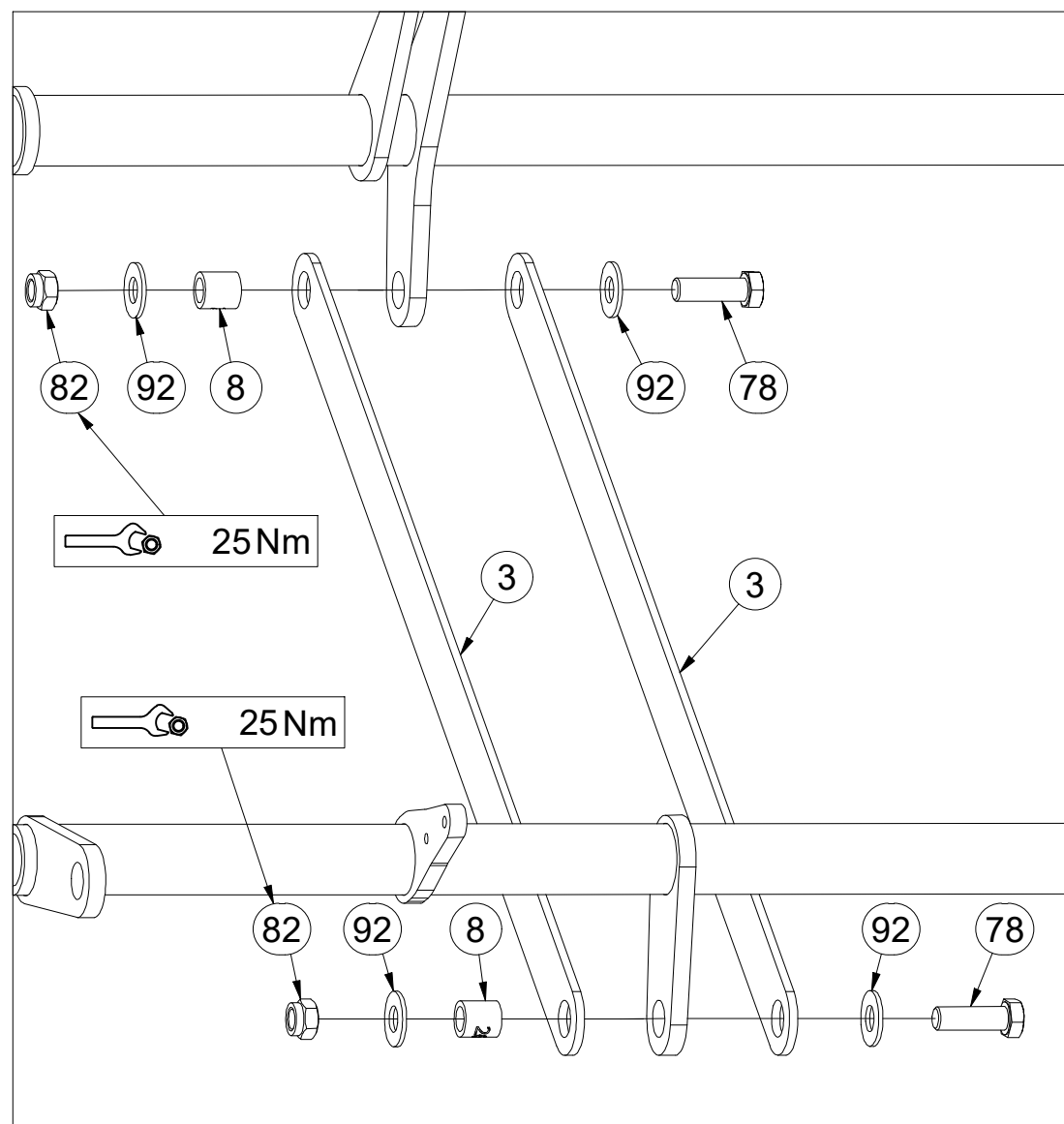
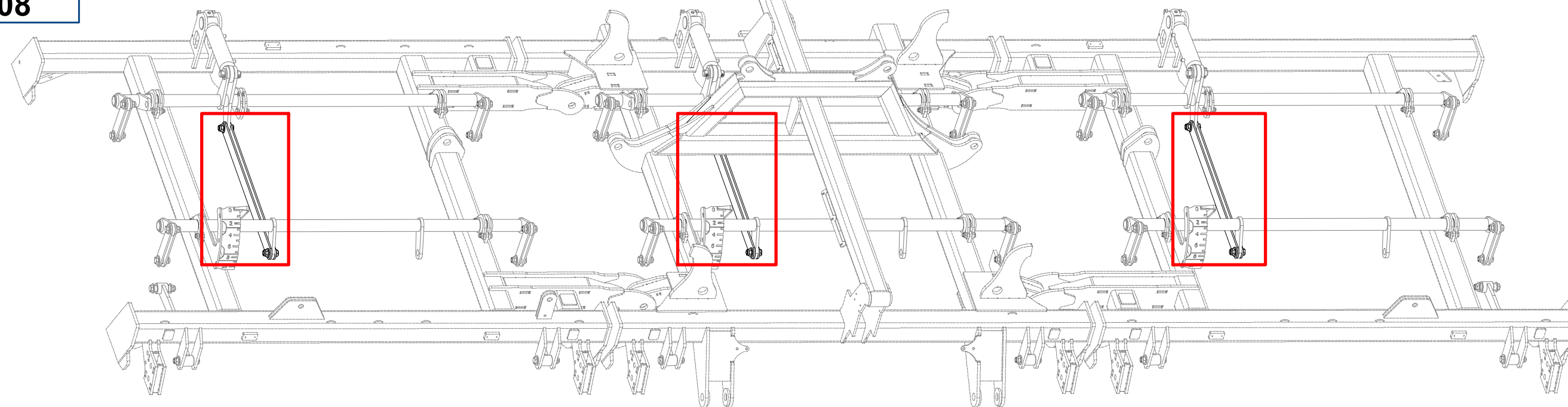

Pos.	Part Number	Pcs.
3	4005334	6
8	4002265	30
78	m04355	30
82	m03683	42
92	m05651	84

CZ SADA OVLÁDÁNÍ RADLIC
 D STEUERSATZ PFLUGSCHAREN
 F KIT DE COMMANDE DES SOCS

GB SET OF PLOUGHSHARE CONTROL
 RU КОМПЛЕКТ УПРАВЛЕНИЯ ЛАП
 PL ZESTAW STEROWANIA RADLICAMI



VZ00043008

Pos.	Part Number	Pcs.
4	4005333	24
8	4002265	30
78	m04355	30
82	m03683	42
92	m05651	84

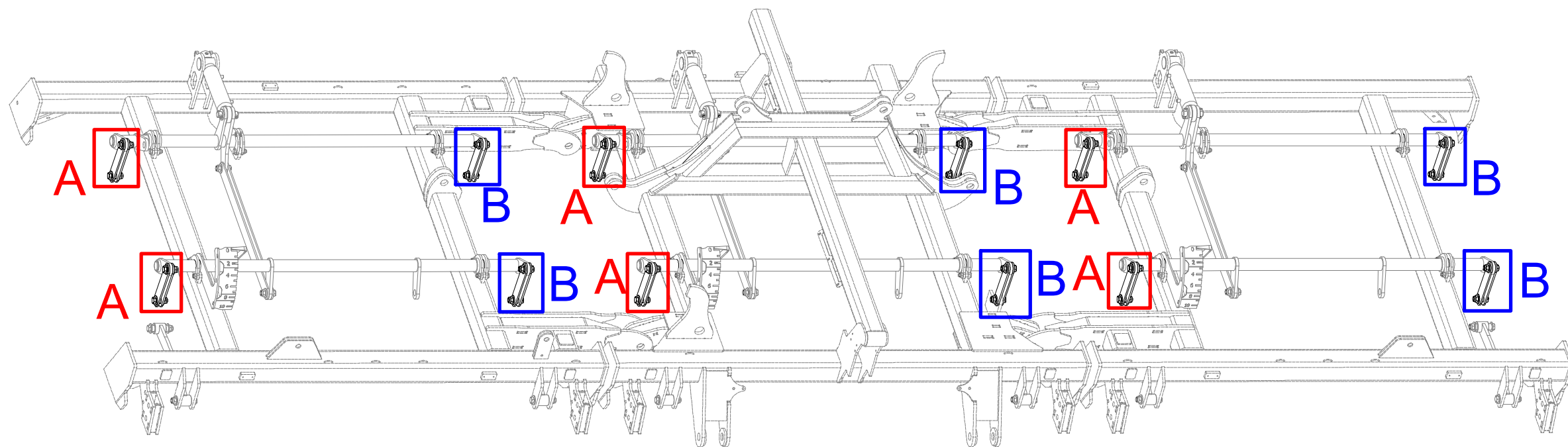

A

B

25Nm

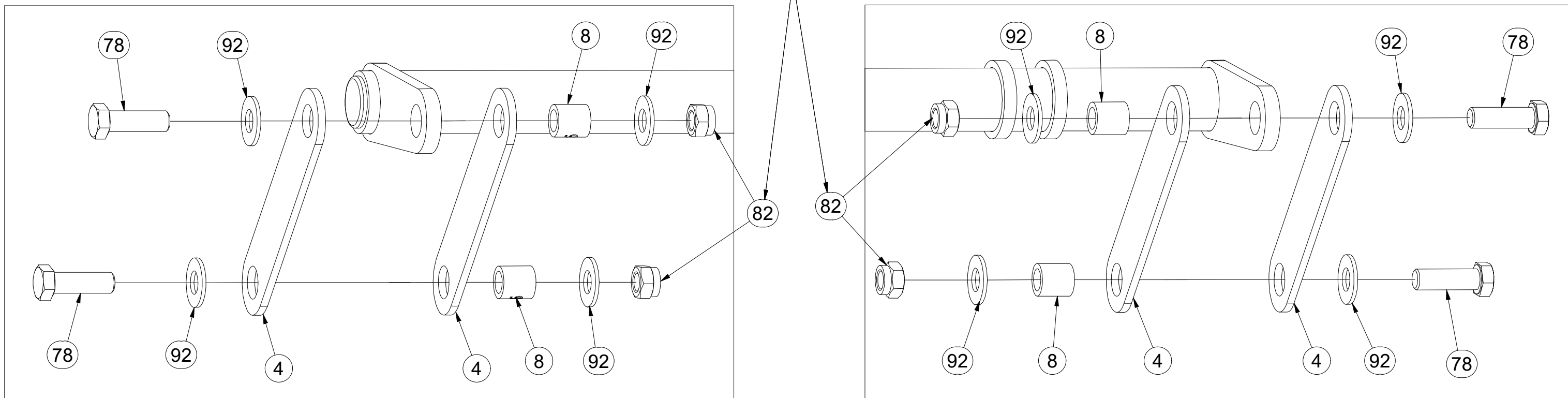

Ⓒ SADA OVLÁDÁNÍ RADLIC

Ⓓ STEUERSATZ PFLUGSCHAREN

Ⓕ KIT DE COMMANDE DES SOCS

Ⓖ SET OF PLOUGHSHARE CONTROL

Ⓔ КОМПЛЕКТ УПРАВЛЕНИЯ ЛАП

Ⓗ ZESTAW STEROWANIA RADLICAMI



VZ00043008

Pos.	Part Number	Pcs.
5	VZ00003342	6
14	9001426	12
74	m07673	12
82	m03683	42
92	m05651	84

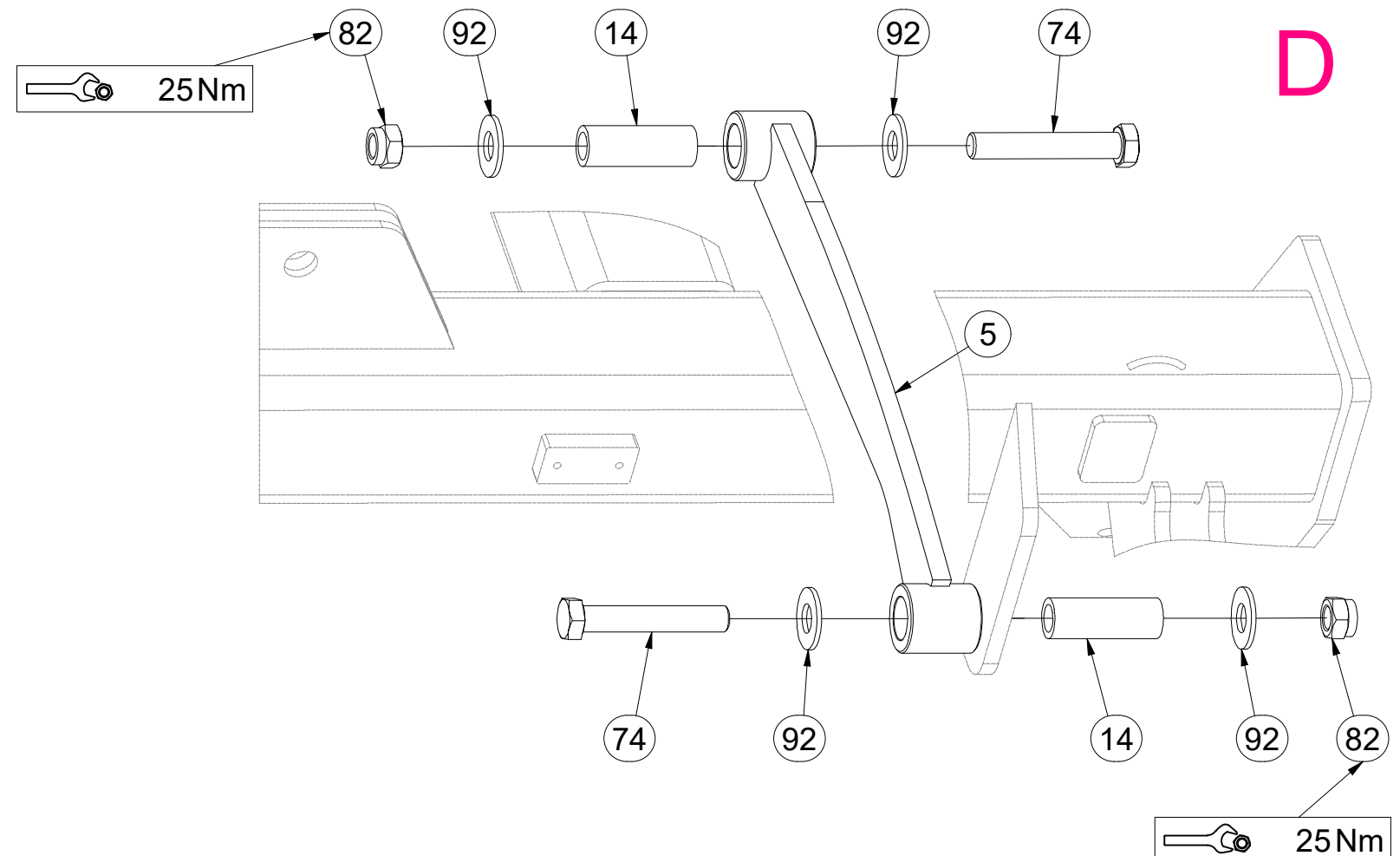
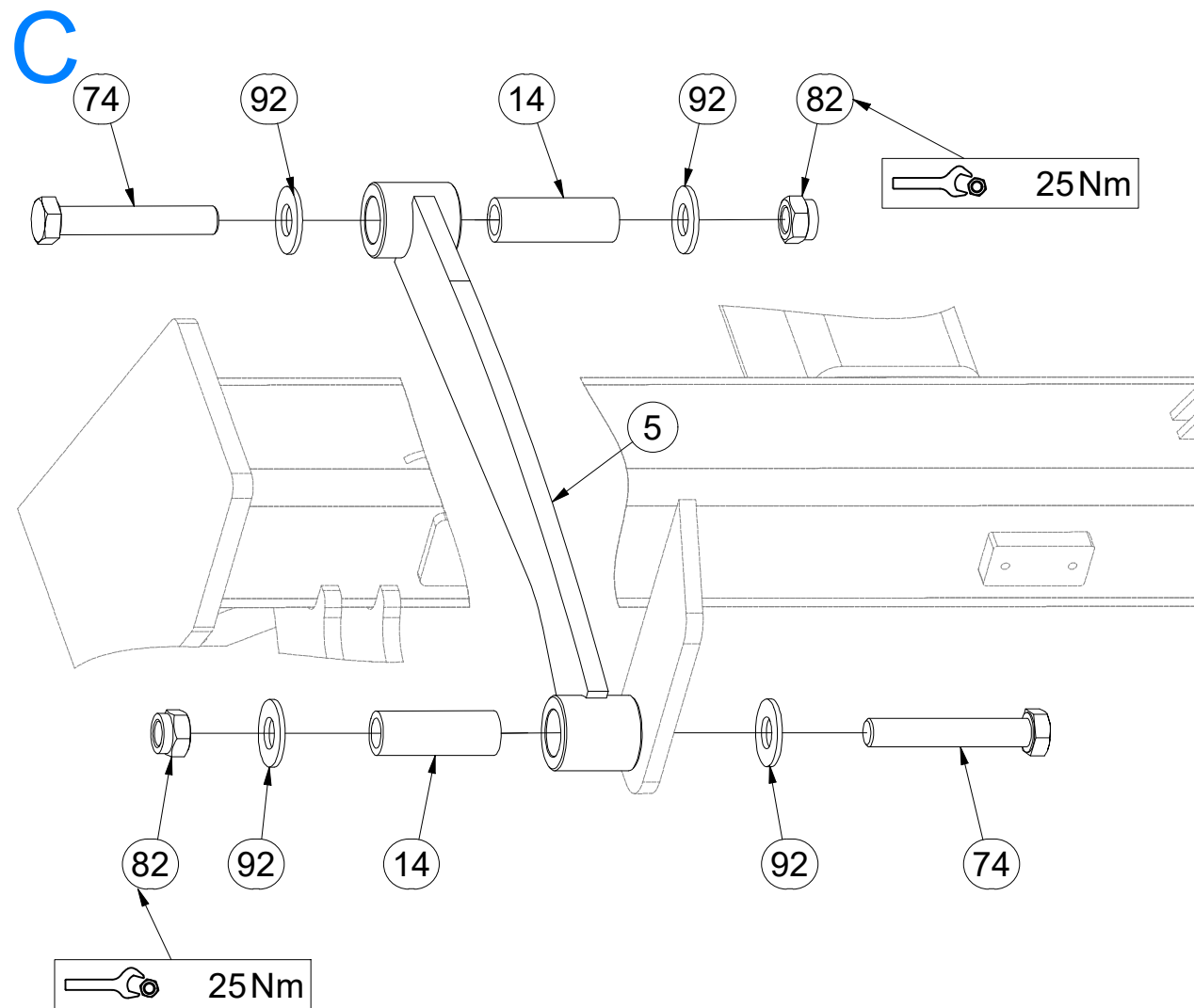
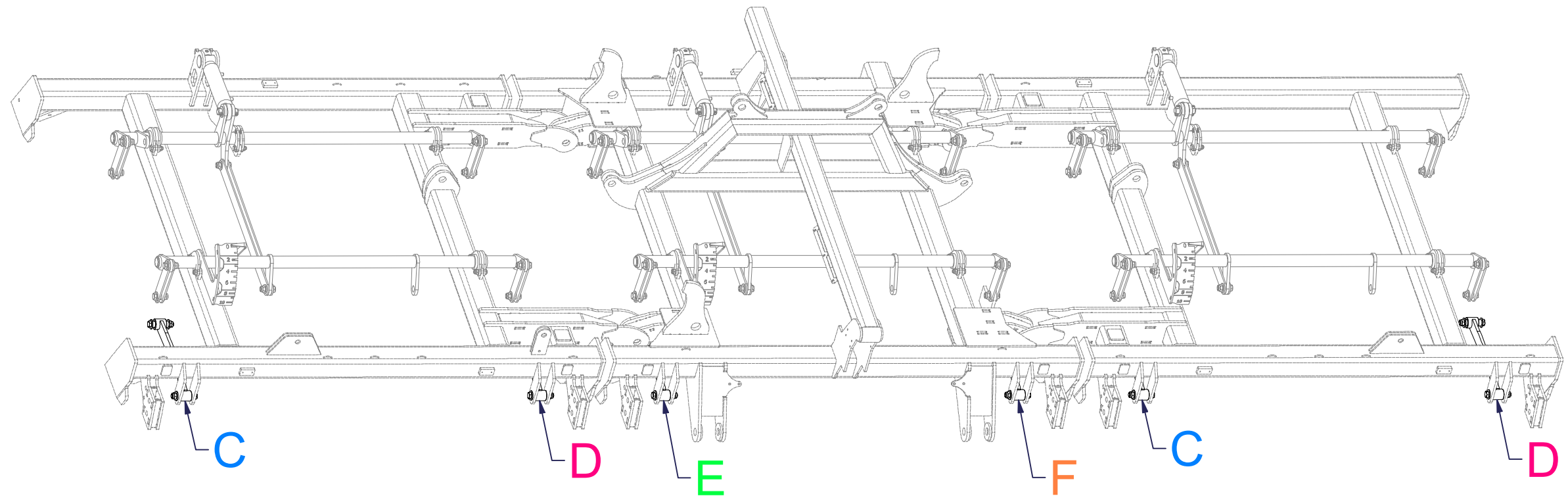

CZ SADA OVLÁDÁNÍ RADLIC
 D STEUERSATZ PFLUGSCHAREN
 F KIT DE COMMANDE DES SOCS

GB SET OF PLOUGHSHARE CONTROL
 RU КОМПЛЕКТ УПРАВЛЕНИЯ ЛАП
 PL ZESTAW STEROWANIA RADLICAMI



VZ00043008

Pos.	Part Number	Pcs.
5	VZ00003342	6
14	9001426	12
74	m07673	12
82	m03683	42
92	m05651	84

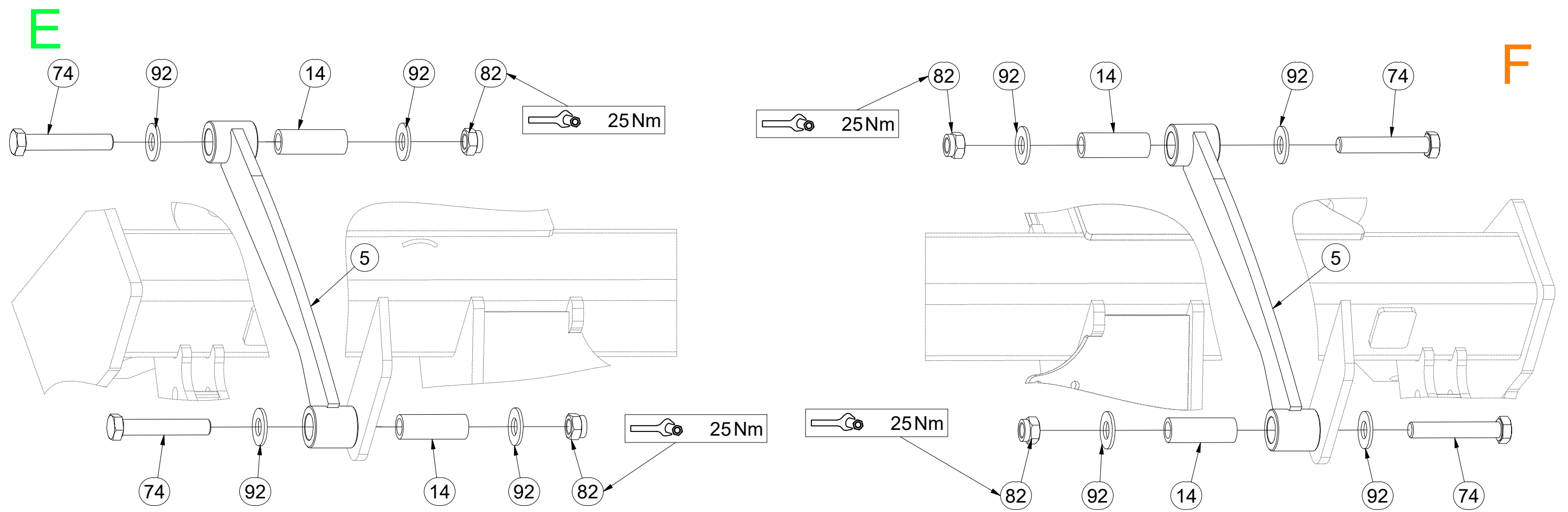
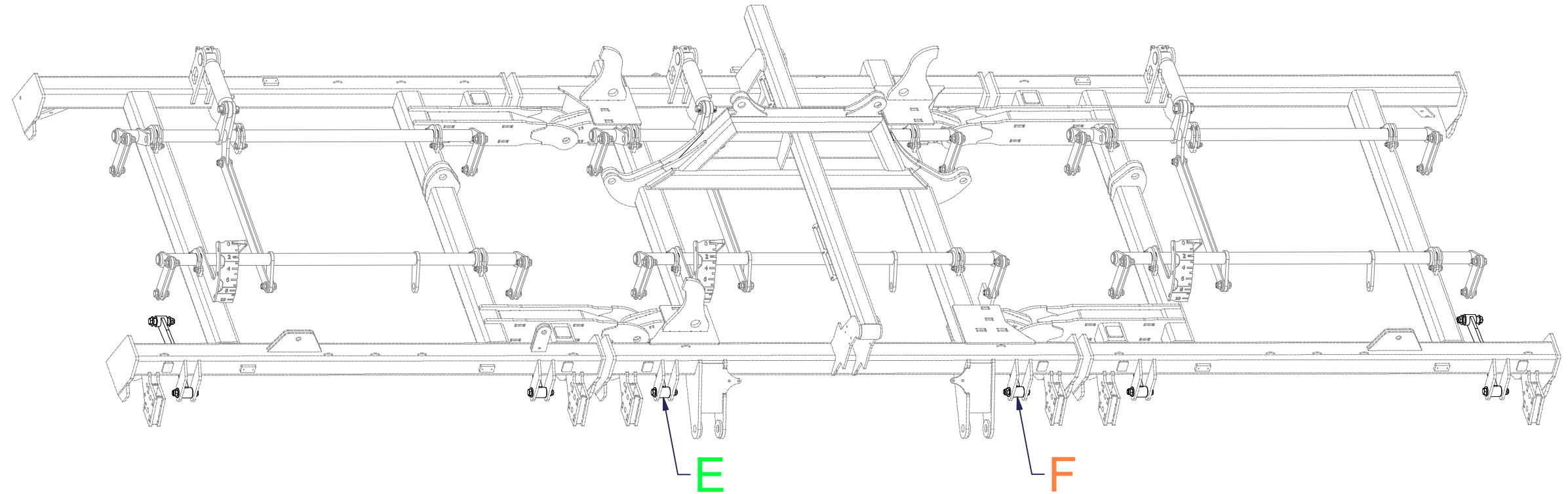

- Ⓒ SADA OVLÁDÁNÍ RADLIC
- Ⓓ STEUERSATZ PFLUGSCHAREN
- Ⓔ KIT DE COMMANDE DES SOCS

- Ⓖ SET OF PLOUGHSHARE CONTROL
- Ⓡ КОМПЛЕКТ УПРАВЛЕНИЯ ЛАП
- Ⓟ ZESTAW STEROWANIA RADLICAMI



VZ00043008

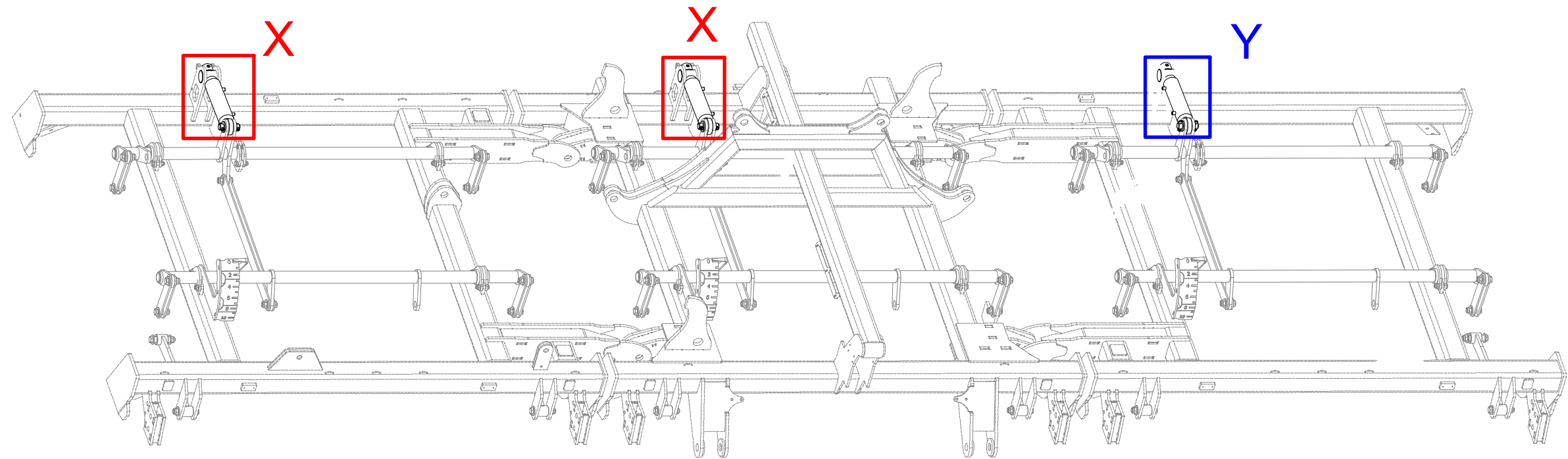

X

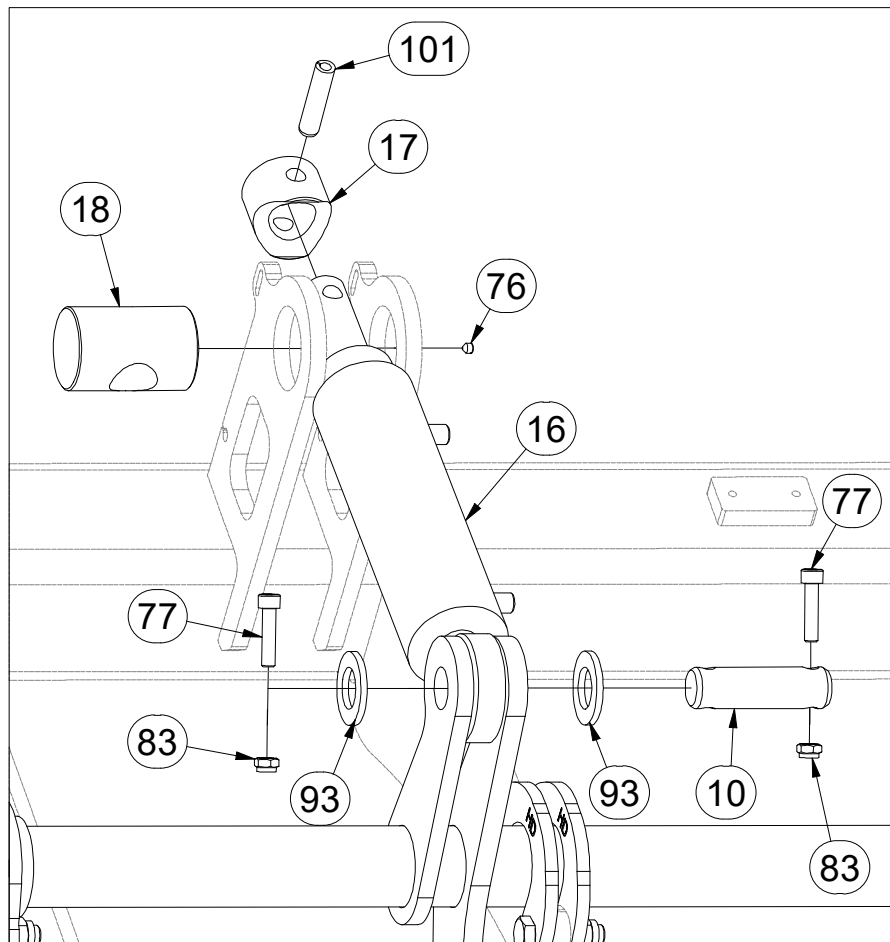

Pos.	Part Number	Pcs.
10	4010390	3
16	VZ00012972	3
17	8000713-40042	3
18	9002114	3
76	m05582	3
77	m09464	6
83	m04503	6
93	m14028	6
101	m05753	3

Y

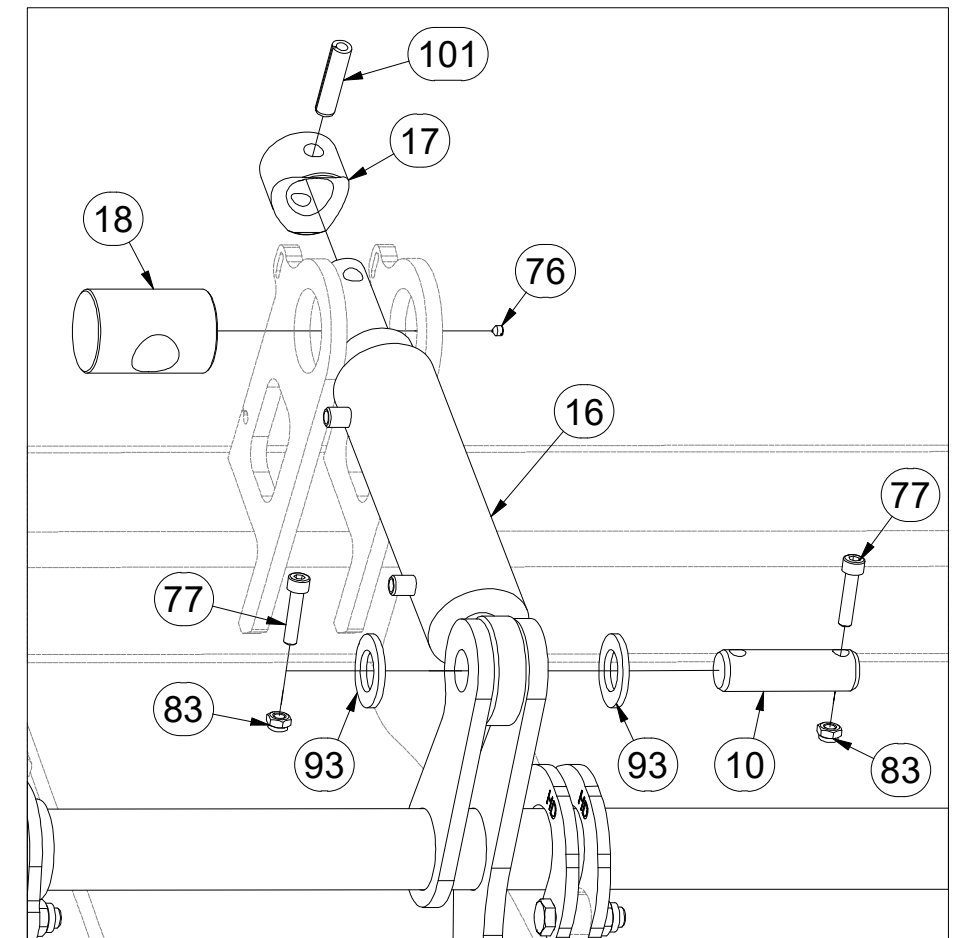

(CZ) SADA OVLÁDÁNÍ RADLIC
 (D) STEUERSATZ PFLUGSCHAREN
 (F) KIT DE COMMANDE DES SOCS

(GB) SET OF PLOUGHSHARE CONTROL
 (RU) КОМПЛЕКТ УПРАВЛЕНИЯ ЛАП
 (PL) ZESTAW STEROWANIA RADLICAMI



VZ00043008

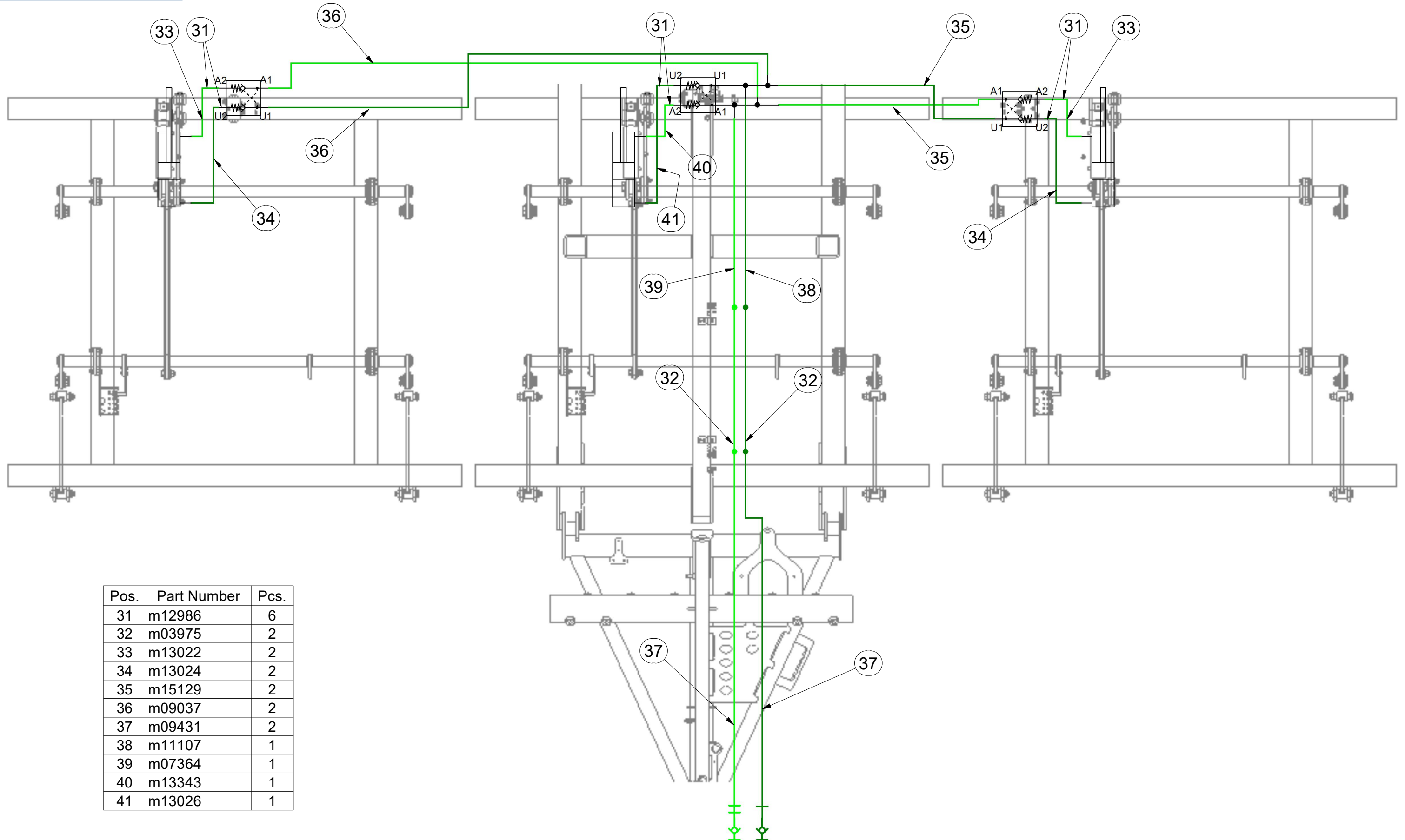

Pos.	Part Number	Pcs.
31	m12986	6
32	m03975	2
33	m13022	2
34	m13024	2
35	m15129	2
36	m09037	2
37	m09431	2
38	m11107	1
39	m07364	1
40	m13343	1
41	m13026	1

Ⓒ SADA OVLÁDÁNÍ RADLIC

Ⓓ STEUERSATZ PFLUGSCHAREN

Ⓕ KIT DE COMMANDE DES SOCS

Ⓖ SET OF PLOUGHSHARE CONTROL

Ⓡ КОМПЛЕКТ УПРАВЛЕНИЯ ЛАП

Ⓟ ZESTAW STEROWANIA RADLICAMI



VZ00043008

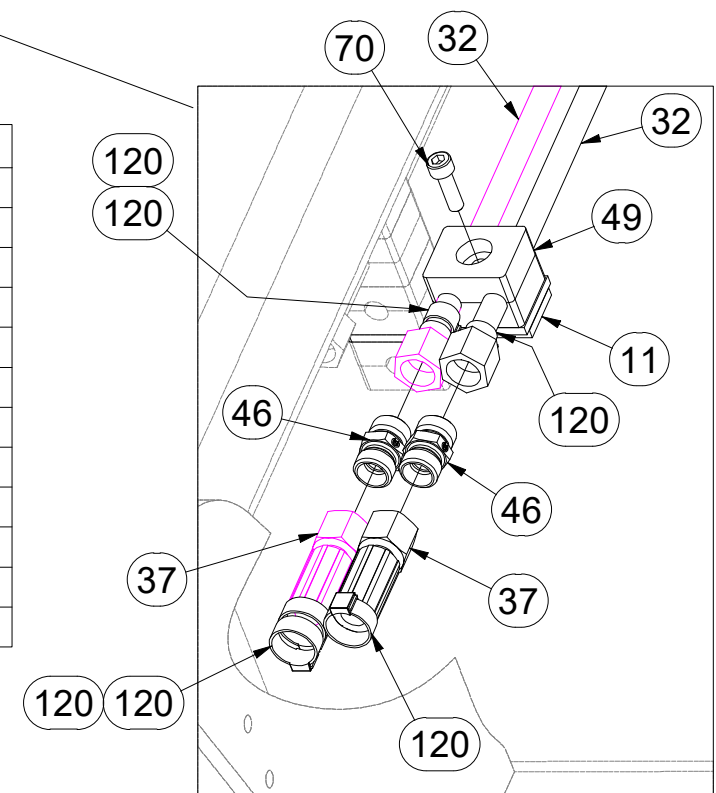
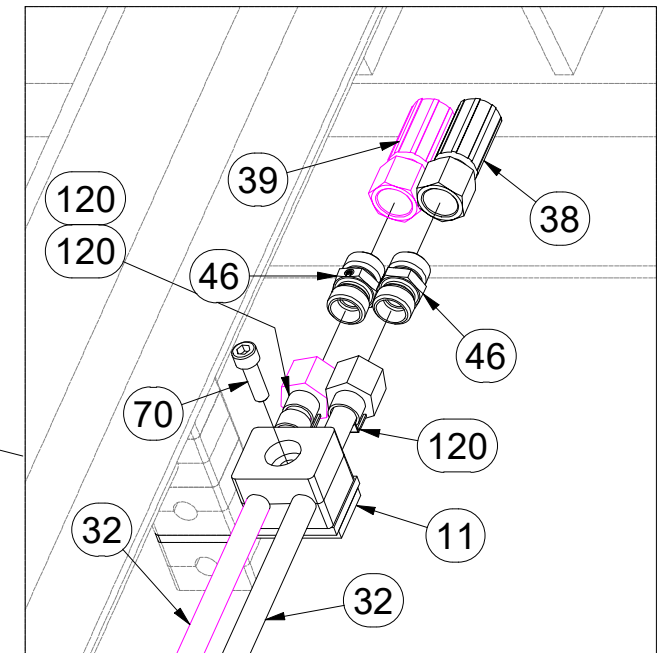
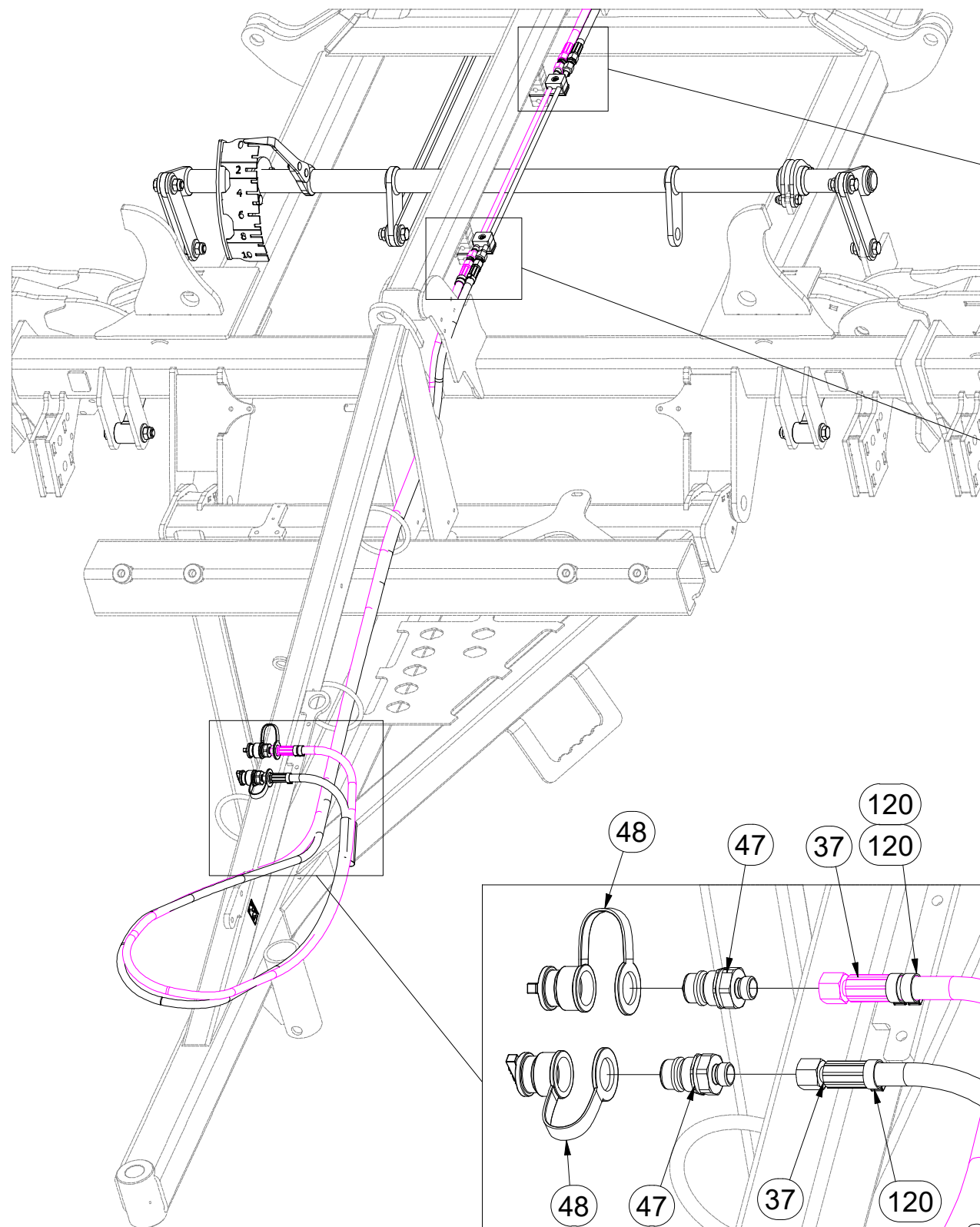

Pos.	Part Number	Pcs.
11	8000713-40018	2
32	m03975	2
37	m09431	2
38	m11107	1
39	m07364	1
46	m03213	4
47	m03849	2
48	m04098	2
49	m05488	2
50	m11183	1
70	m04346	2
120	m11282	36

Ⓒ SADA OVLÁDÁNÍ RADLIC

Ⓓ STEUERSATZ PFLUGSCHAREN

Ⓕ KIT DE COMMANDE DES SOCS

Ⓖ SET OF PLOUGHSHARE CONTROL

Ⓡ КОМПЛЕКТ УПРАВЛЕНИЯ ЛАП

Ⓟ ZESTAW STEROWANIA RADLICAMI



VZ00043008

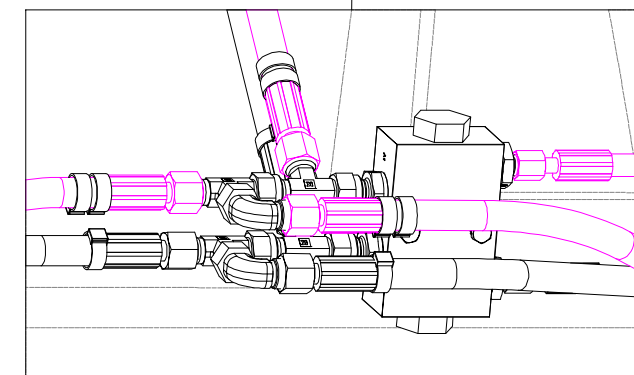
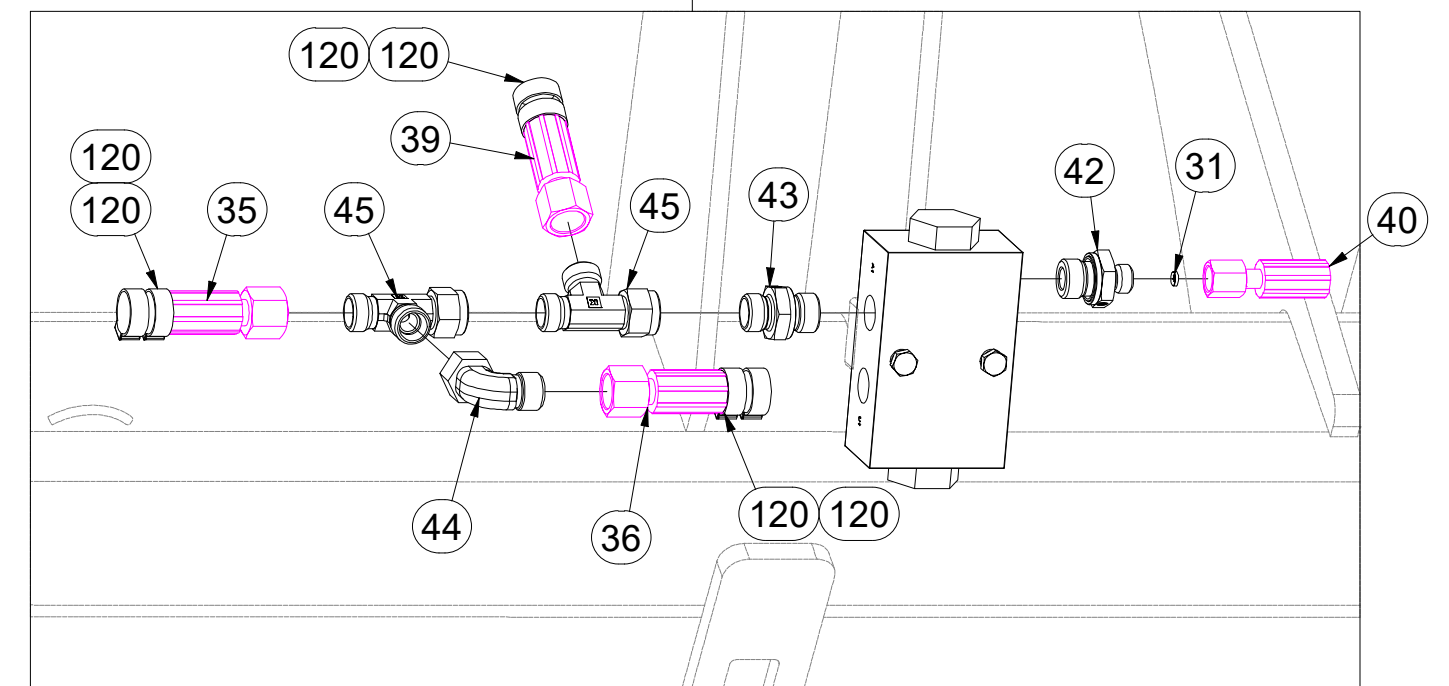
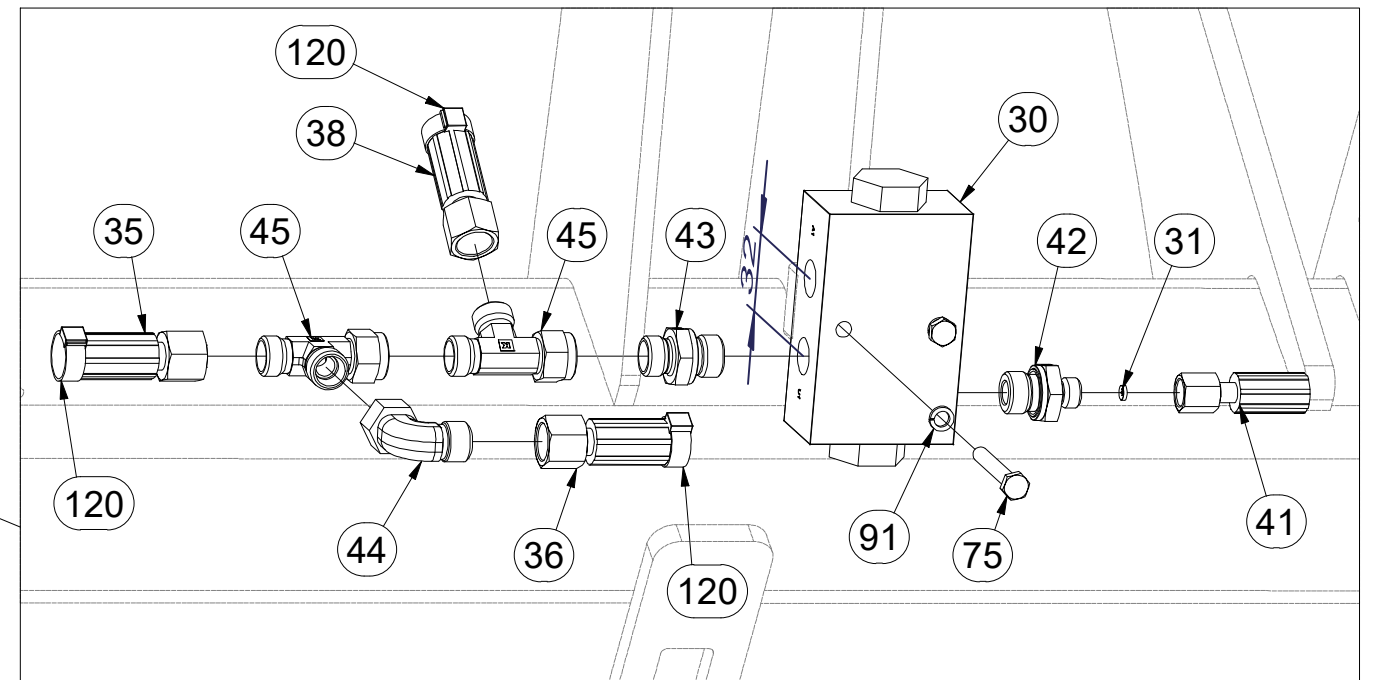
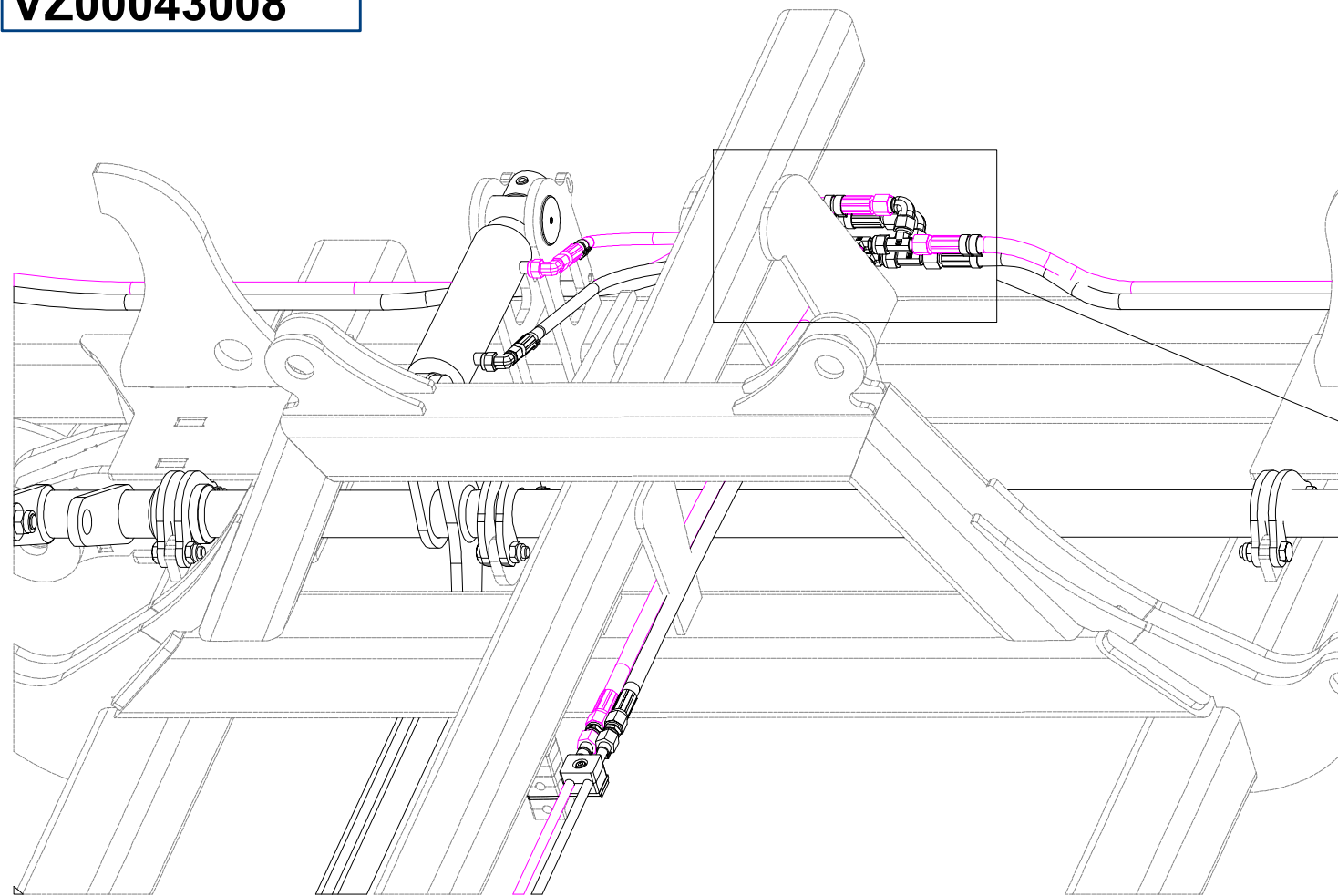

Pos.	Part Number	Pcs.
30	m09911	3
31	m12986	6
35	m15129	2
36	m09037	2
38	m11107	1
39	m07364	1
40	m13343	1
41	m13026	1
42	m12951	6
43	m06528	6
44	m06803	2
45	m07568	4
75	m05561	6
91	m01200	6
120	m11282	36

CZ SADA OVLÁDÁNÍ RADLIC
 D STEUERSATZ PFLUGSCHAREN
 F KIT DE COMMANDE DES SOCS

GB SET OF PLOUGHSHARE CONTROL
 RU КОМПЛЕКТ УПРАВЛЕНИЯ ЛАП
 PL ZESTAW STEROWANIA RADLICAMI



VZ00043008

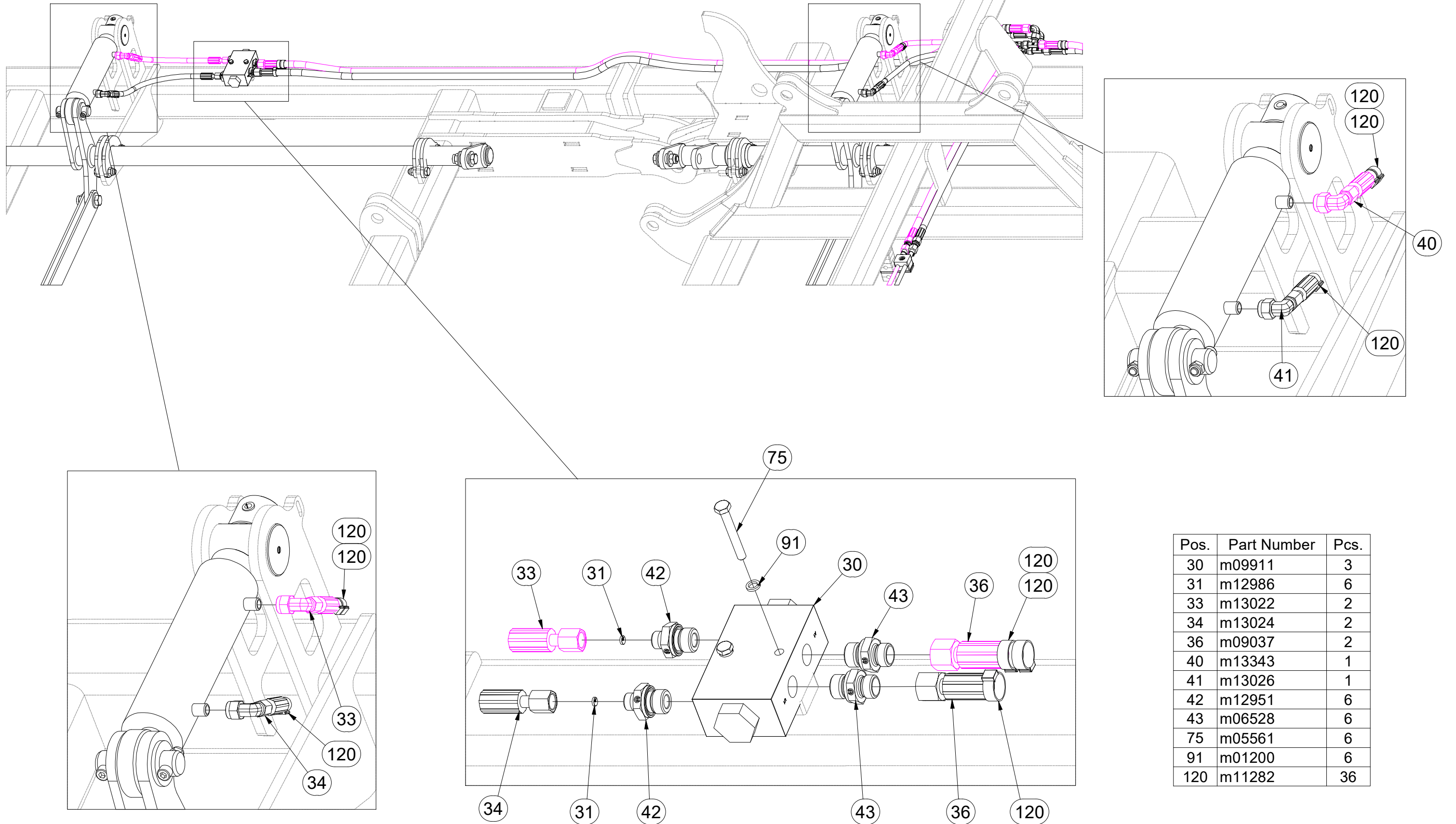

Pos.	Part Number	Pcs.
30	m09911	3
31	m12986	6
33	m13022	2
34	m13024	2
36	m09037	2
40	m13343	1
41	m13026	1
42	m12951	6
43	m06528	6
75	m05561	6
91	m01200	6
120	m11282	36

Ⓒ SADA OVLÁDÁNÍ RADLIC

Ⓓ STEUERSATZ PFLUGSCHAREN

Ⓕ KIT DE COMMANDE DES SOCS

Ⓖ SET OF PLOUGHSHARE CONTROL

Ⓡ КОМПЛЕКТ УПРАВЛЕНИЯ ЛАП

Ⓢ ZESTAW STEROWANIA RADLICAMI



VZ00043008

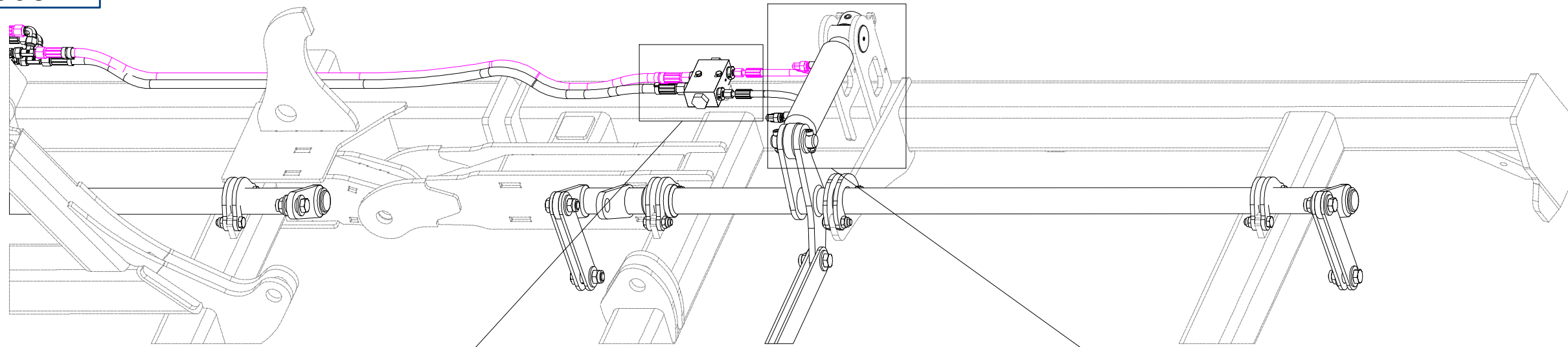

Pos.	Part Number	Pcs.	Pos.	Part Number	Pcs.
30	m09911	3	42	m12951	6
31	m12986	6	43	m06528	6
33	m13022	2	75	m05561	6
34	m13024	2	91	m01200	6
35	m15129	2	120	m11282	36

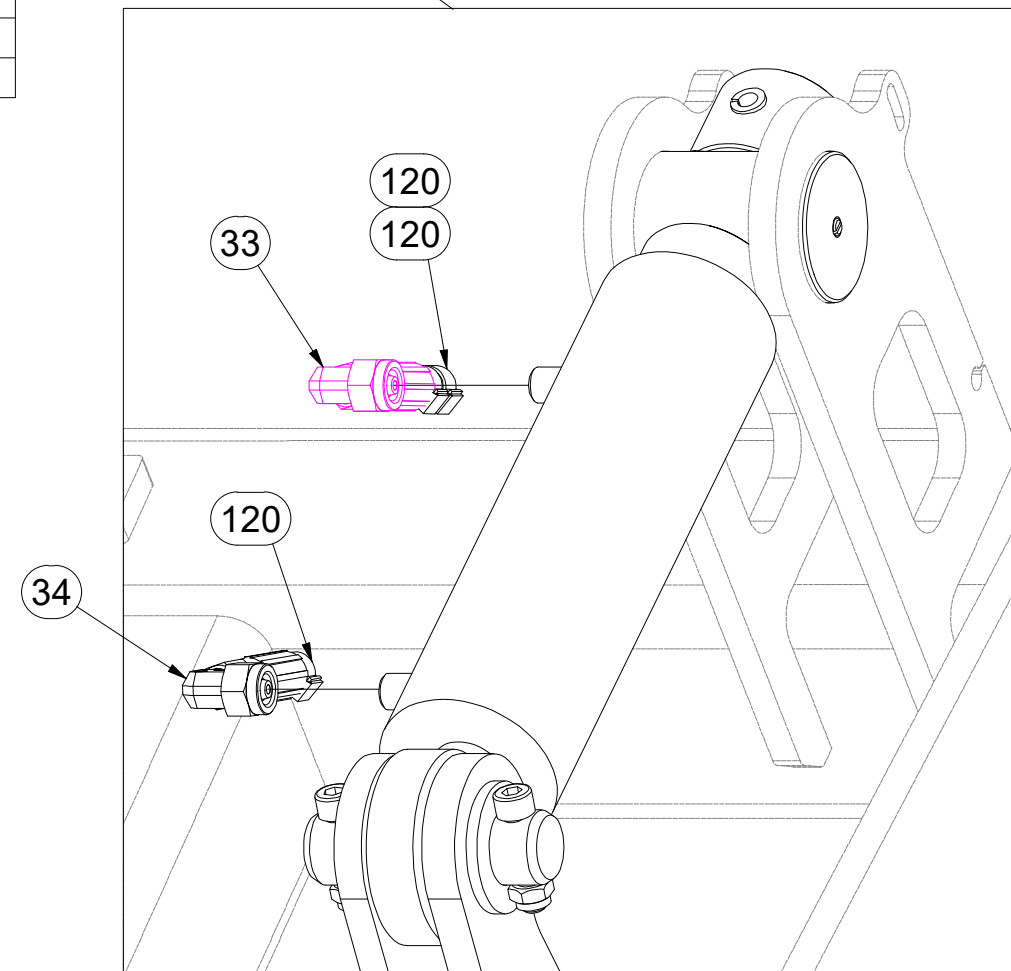
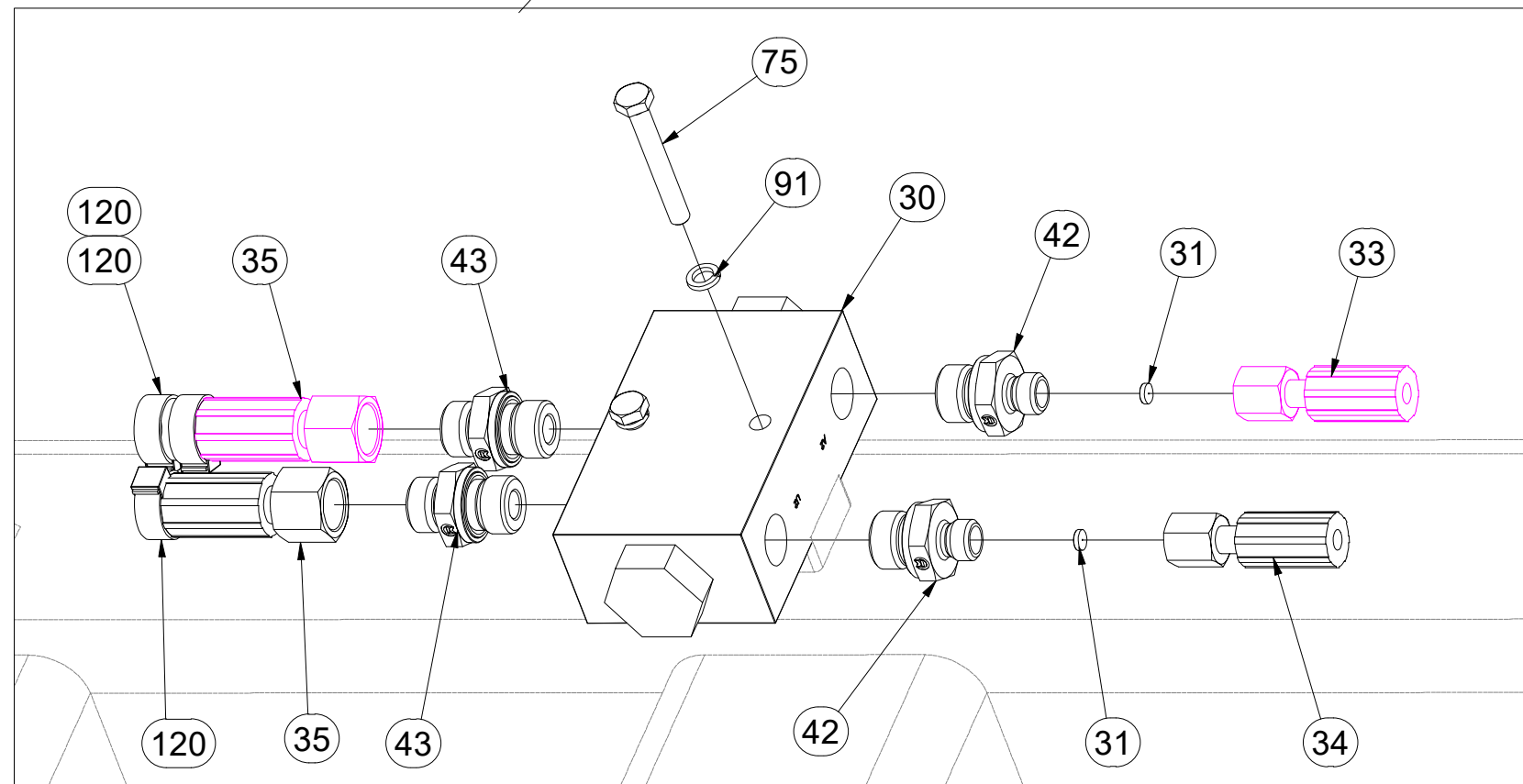

Ⓒ SADA RADLIC

Ⓓ SCHARSATZ

Ⓕ KIT DE SOCS

Ⓖ SET OF PLOUGHSHARES

Ⓡ КОМПЛЕКТ ЛАП

Ⓟ ZESTAW REDLIC



VZ00043051

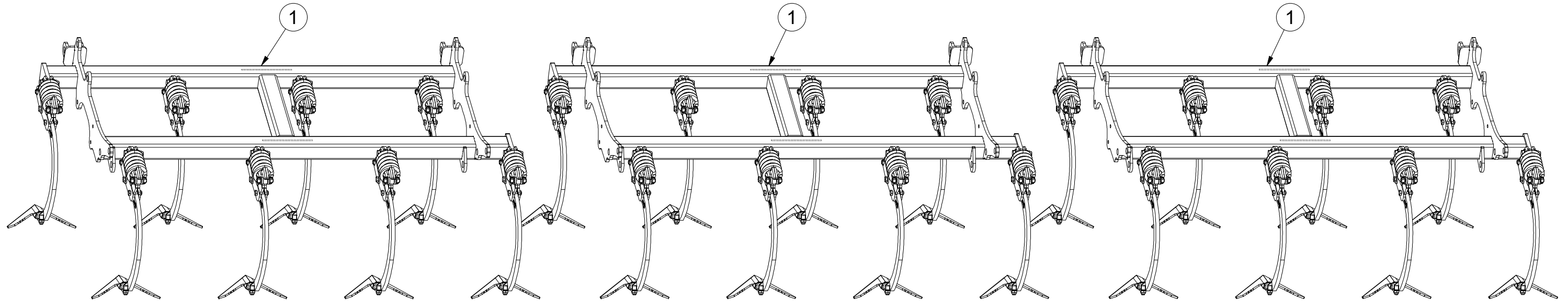

Pos.	Part Number	Pcs.
1	VZ00015183	3

Ⓒ SADA RADLIC

Ⓓ SCHARSATZ

Ⓕ KIT DE SOCS

VZ00015183

Ⓖ SET OF PLOUGHSHARES

Ⓡ КОМПЛЕКТ ЛАП

Ⓟ ZESTAW REDLIC

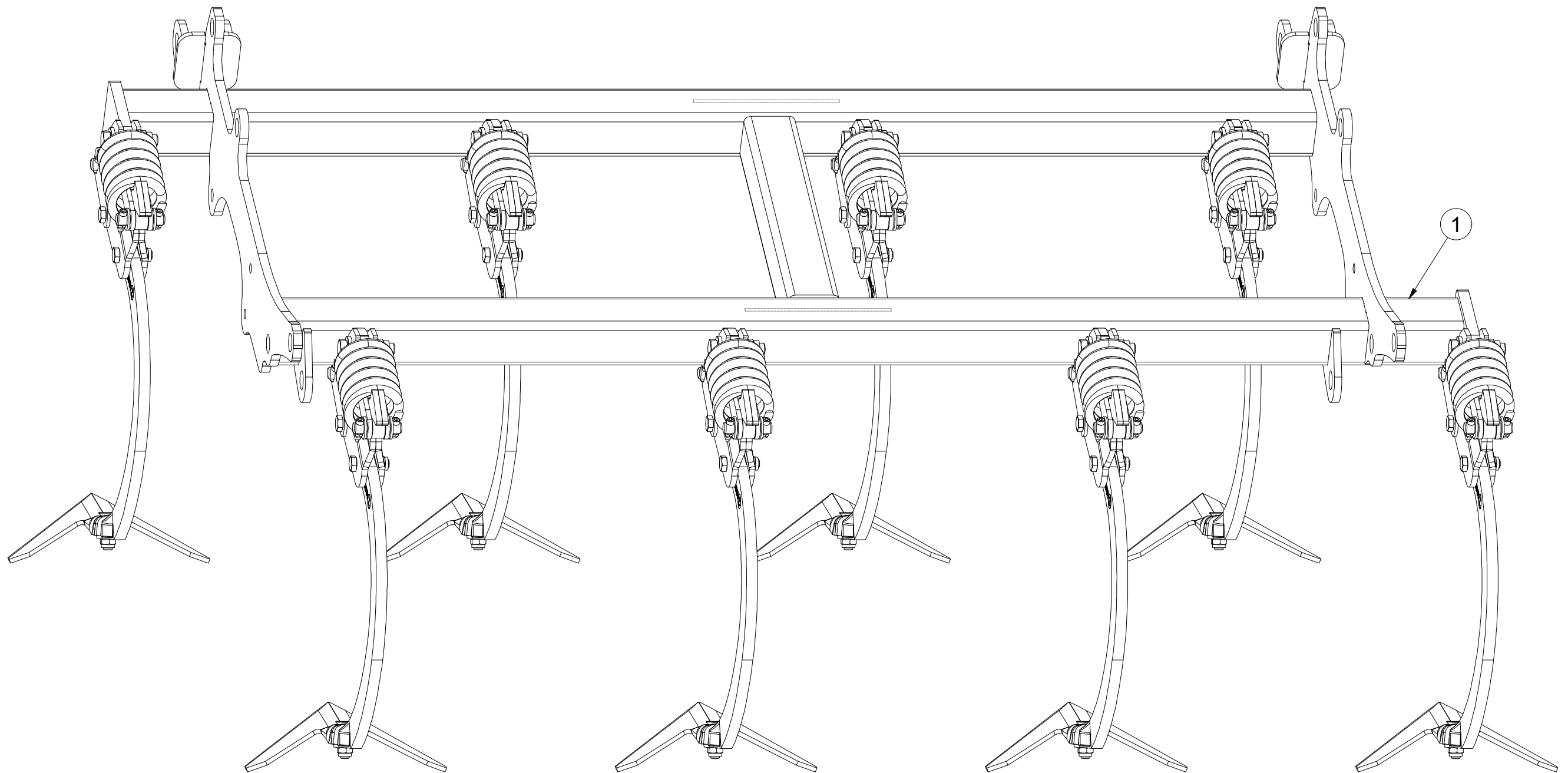

Pos.	Part Number	Pcs.
1	VZ00015184	1

Ⓒ SADA RADLIC

Ⓓ SCHARSATZ

Ⓕ KIT DE SOCS

Ⓖ SET OF PLOUGHSHARES

Ⓡ КОМПЛЕКТ ЛАП

Ⓟ ZESTAW REDLIC



VZ00015183

Pos.	Part Number	Pcs.	Pos.	Part Number	Pcs.	Pos.	Part Number	Pcs.
2	9005683	8	11	m18880	8	30	m05560	16
3	3012358	8	12	m18882	8	31	m04301	16
4	3012359	8	13	3000236-KOO	8	32	m03683	8
5	4024906	16	20	m10440	8	33	m21001	8
6	4024918	8	21	m15215	16	34	m18478	8
7	4009624	8	22	m06077	8	40	m14971	16
8	4014252	16	23	m03339	8	50	m18826	8
9	4015783	8	24	m23536	8	70	4014863	16
10	VZ00003688	8						

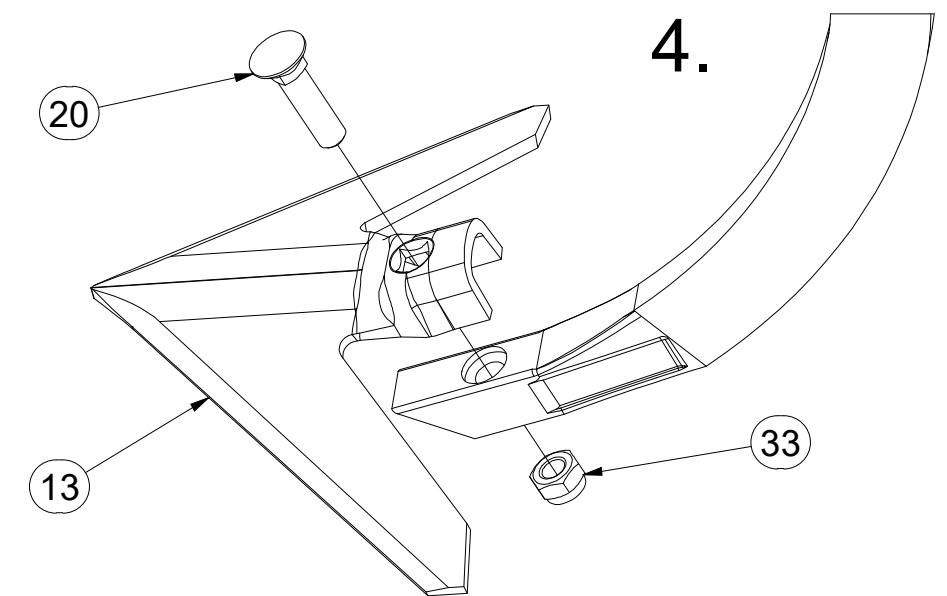
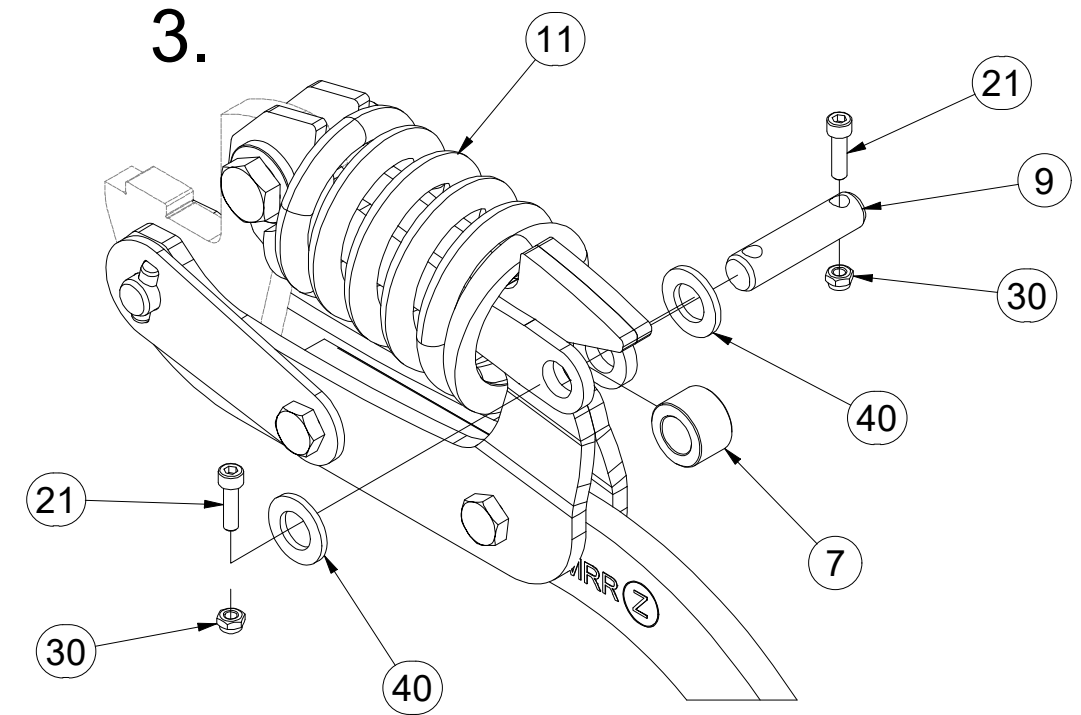
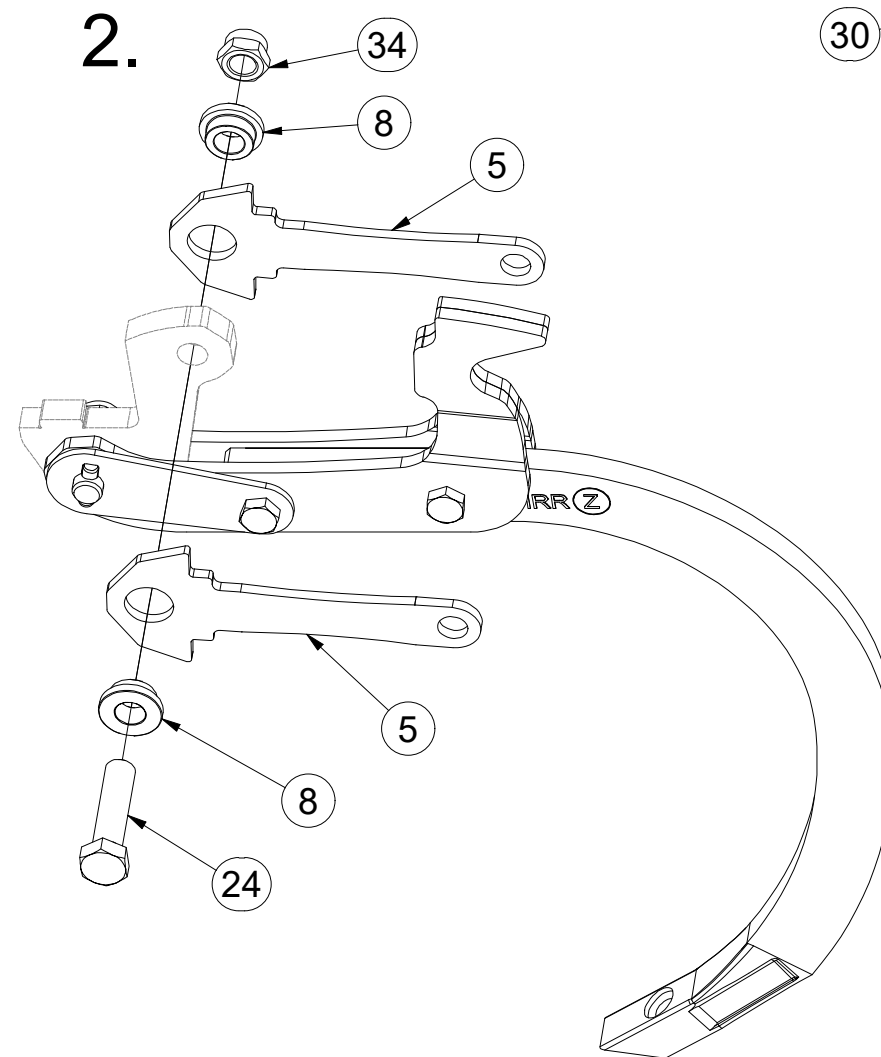
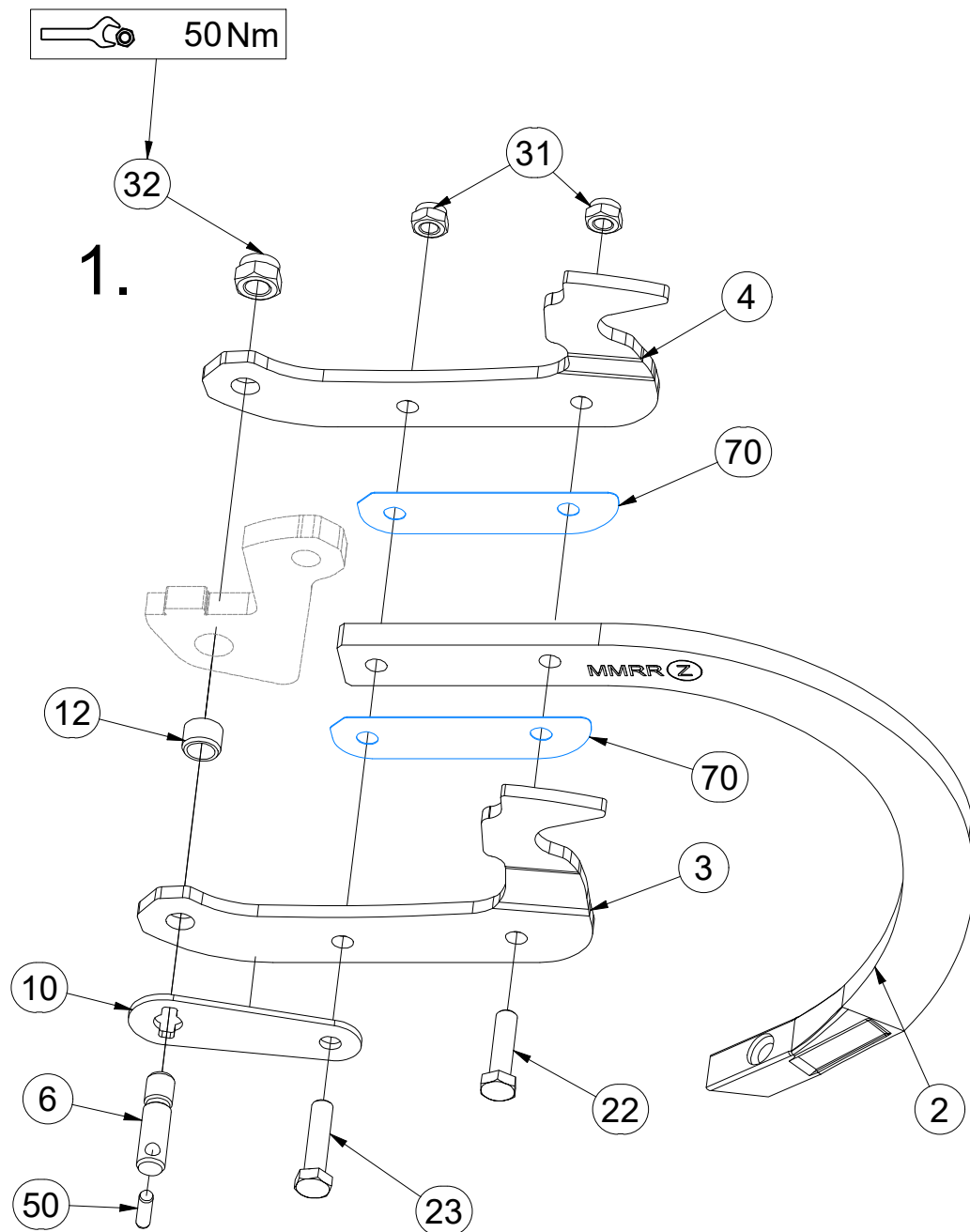

Ⓒ SADA SMYKŮ RADLIC

Ⓓ SATZ SCHARSCHLEPPEN

Ⓕ KIT DE NIVELEURS DES SOCS

Ⓖ SET OF PLOUGHSHARE LEVELLING BARS

Ⓡ КОМПЛЕКТ БОРОН ЛАП

Ⓟ ZESTAW WŁÓK REDLIC

Farmet

VZ00043052

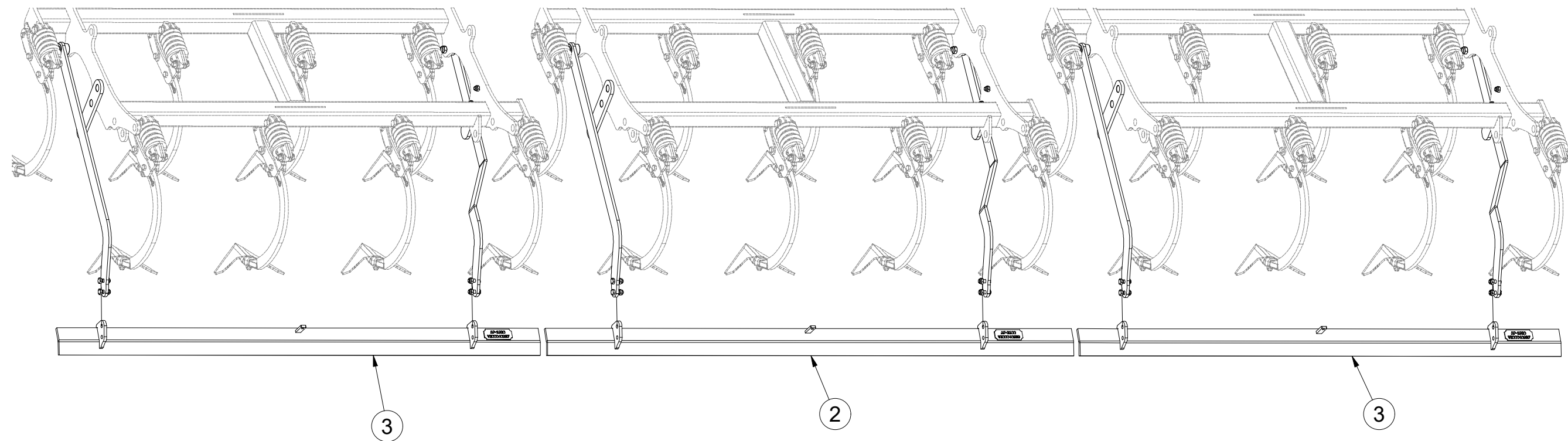

Pos.	Part Number	Pcs.
2	VZ00040939	1
3	VZ00040937	2

Ⓒ SADA SMYKŮ RADLIC

Ⓓ SATZ SCHARSCHLEPPEN

Ⓕ KIT DE NIVELEURS DES SOCS

Ⓖ SET OF PLOUGHSHARE LEVELLING BARS

Ⓡ КОМПЛЕКТ БОРОН ЛАП

Ⓟ ZESTAW WŁÓK REDLIC



VZ00043052

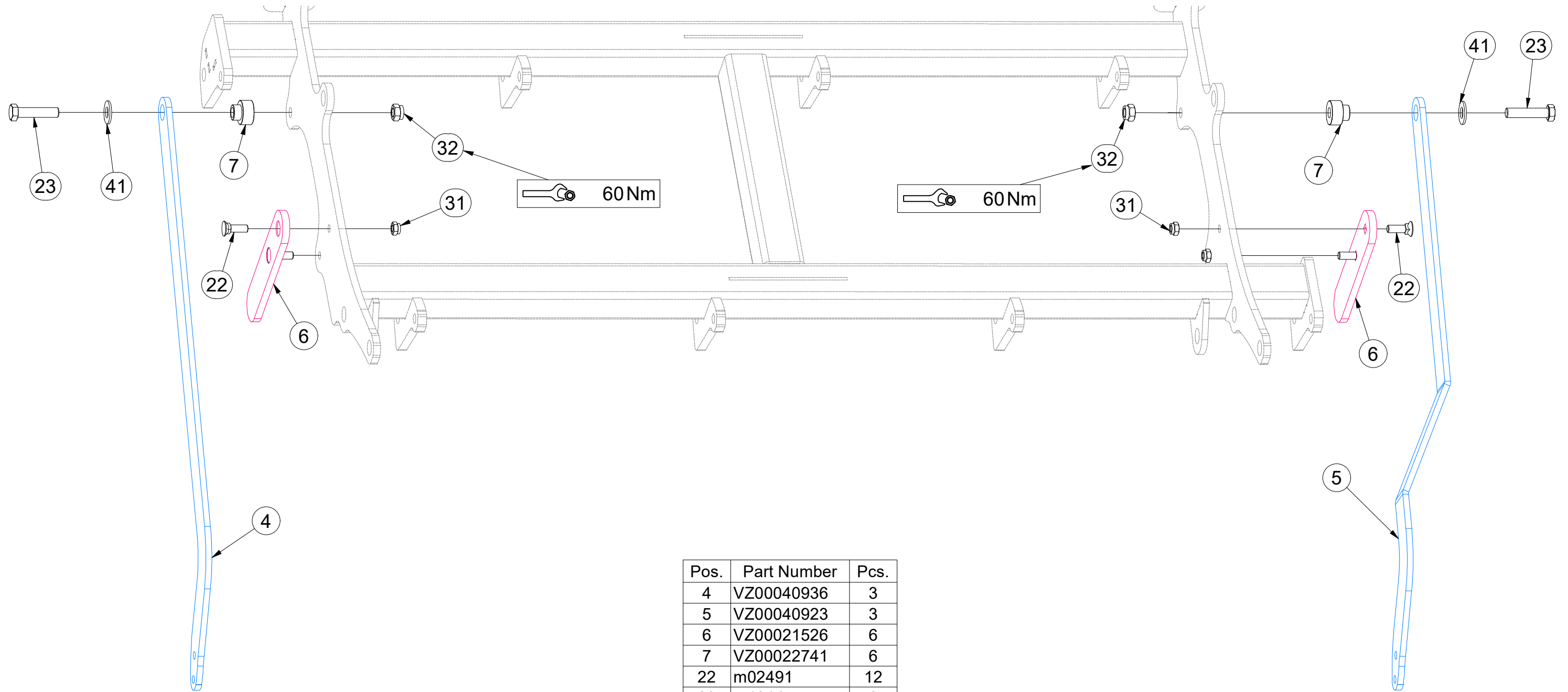

Pos.	Part Number	Pcs.
4	VZ00040936	3
5	VZ00040923	3
6	VZ00021526	6
7	VZ00022741	6
22	m02491	12
23	m18147	6
31	m04301	24
32	m03683	6
41	m05651	6

Ⓒ SADA SMYKŮ RADLIC

Ⓓ SATZ SCHARSCHLEPPEN

Ⓕ KIT DE NIVELEURS DES SOCS

Ⓖ SET OF PLOUGHSHARE LEVELLING BARS

Ⓡ КОМПЛЕКТ БОРОН ЛАП

Ⓟ ZESTAW WŁÓK REDLIC



VZ00043052

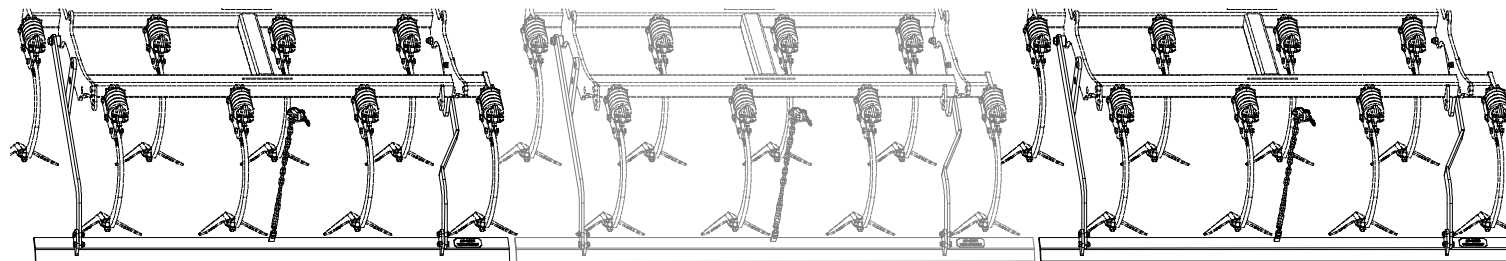

Pos.	Part Number	Pcs.
3	VZ00040937	2
21	m04343	12
31	m04301	24

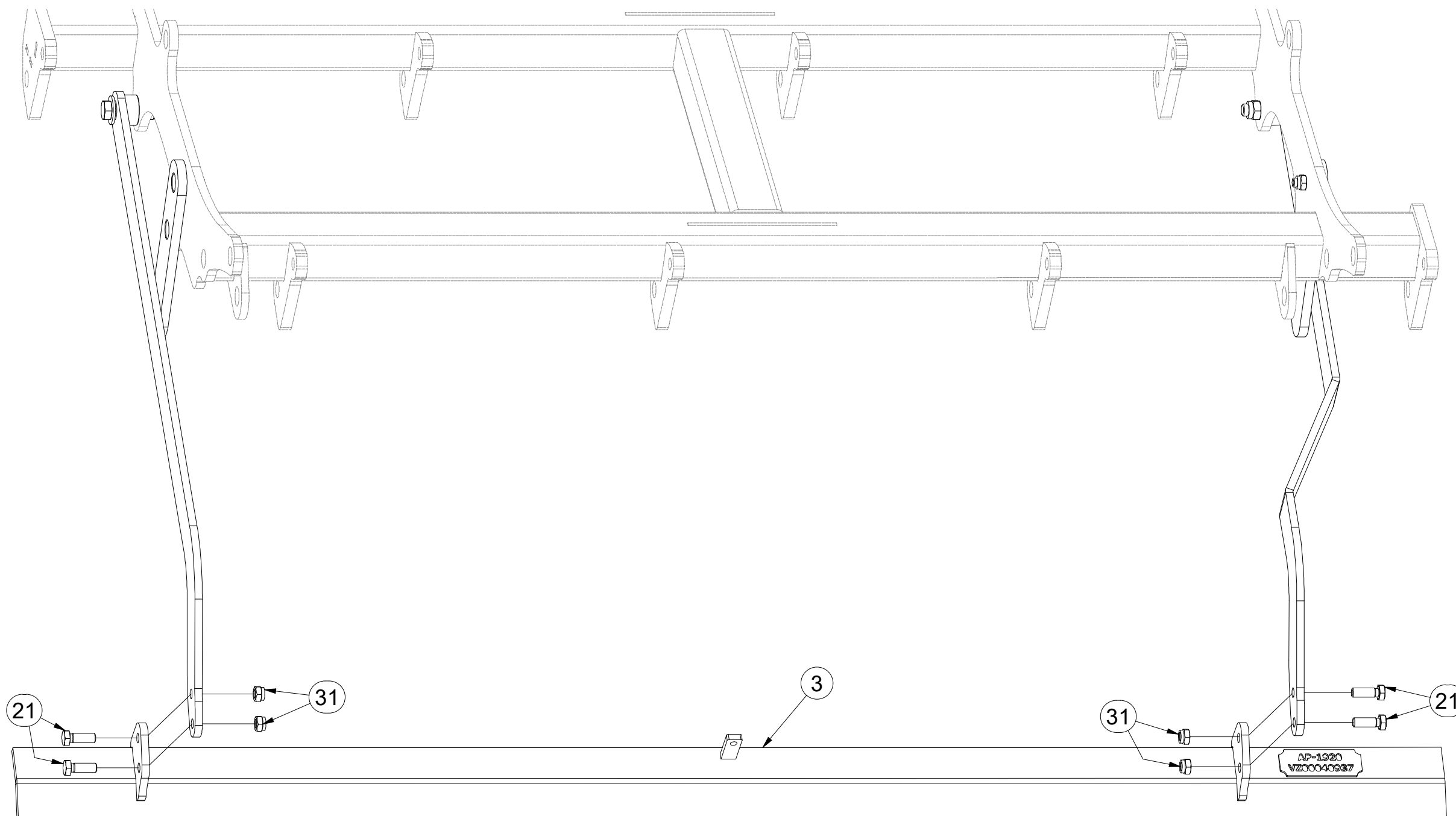

Ⓒ SADA SMYKŮ RADLIC

Ⓓ SATZ SCHARSCHLEPPEN

Ⓕ KIT DE NIVELEURS DES SOCS

Ⓖ SET OF PLOUGHSHARE LEVELLING BARS

Ⓡ КОМПЛЕКТ БОРОН ЛАП

Ⓟ ZESTAW WŁÓK REDLIC



VZ00043052

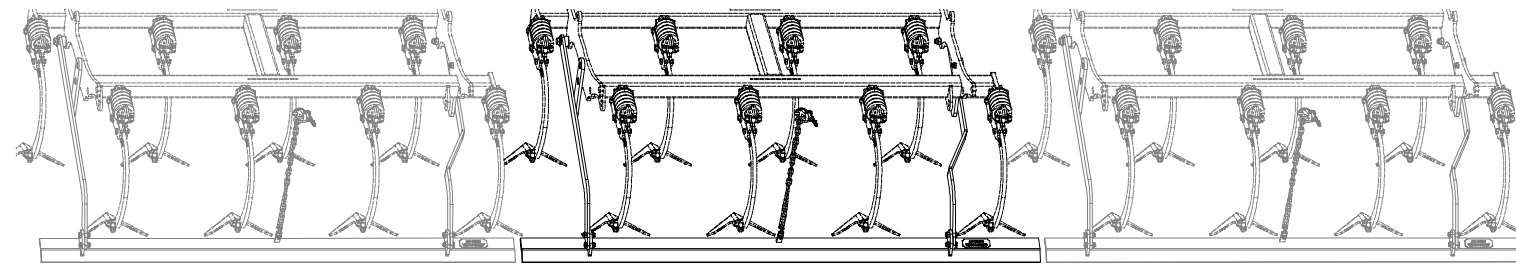

Pos.	Part Number	Pcs.
2	VZ00040939	1
21	m04343	12
31	m04301	24

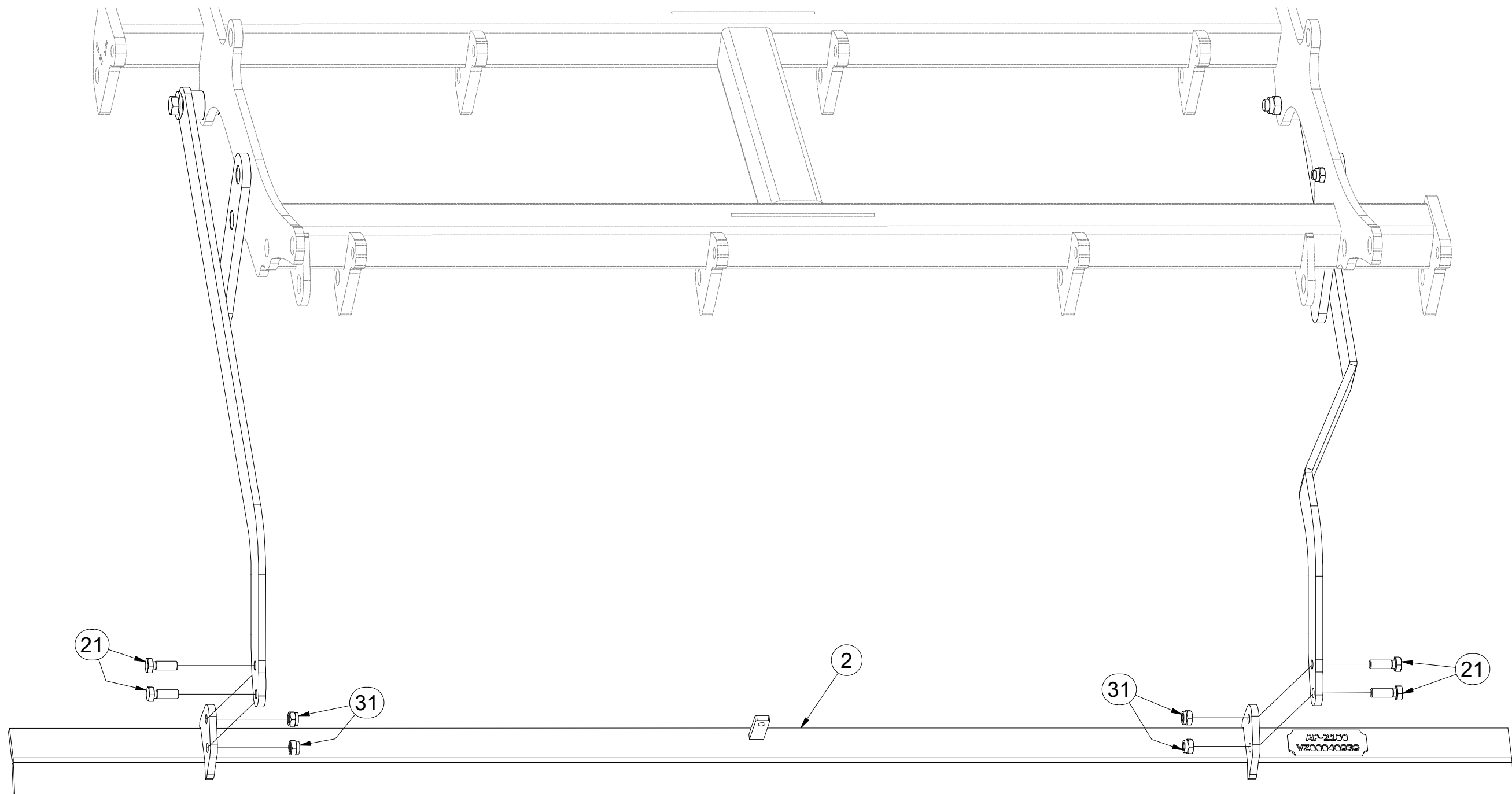

Ⓒ SADA SMYKŮ RADLIC

Ⓓ SATZ SCHARSCHLEPPEN

Ⓕ KIT DE NIVELEURS DES SOCS

Ⓖ SET OF PLOUGHSHARE LEVELLING BARS

Ⓡ КОМПЛЕКТ БОРОН ЛАП

Ⓟ ZESTAW WŁÓK REDLIC



VZ00043052

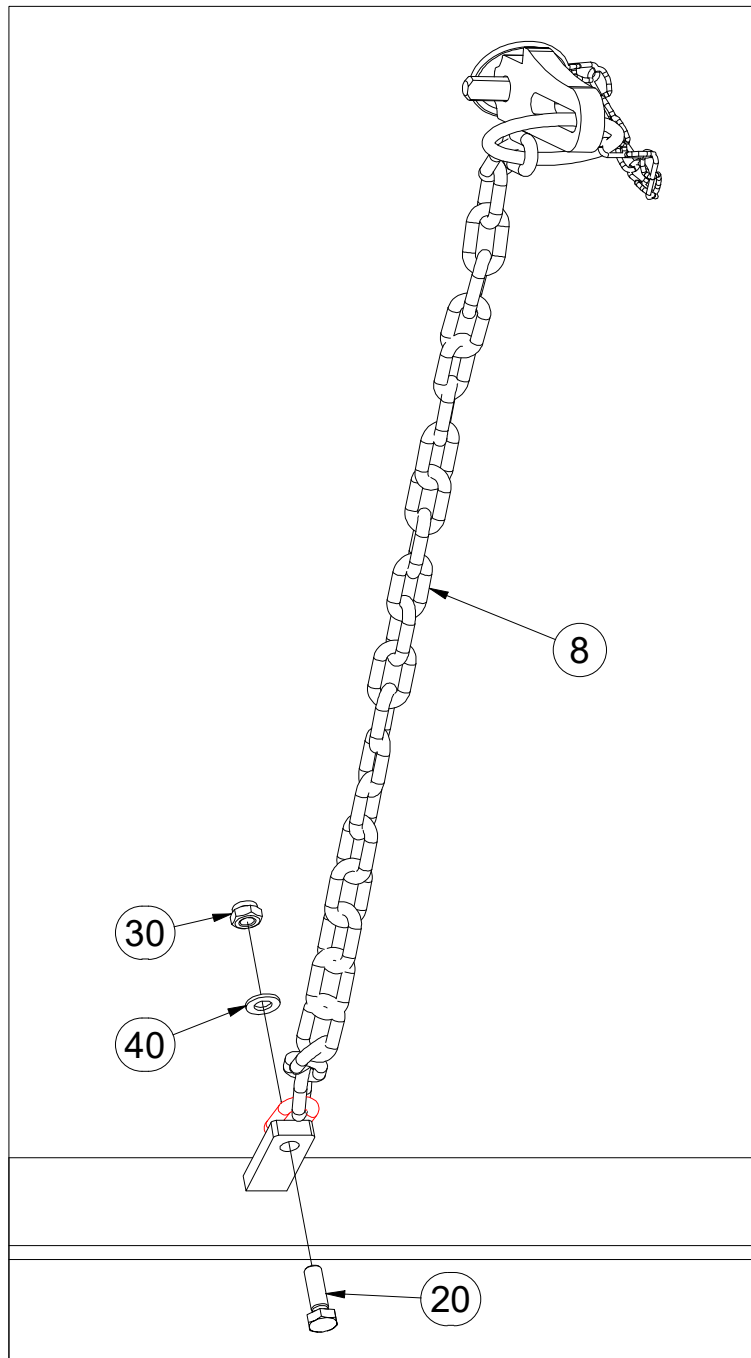
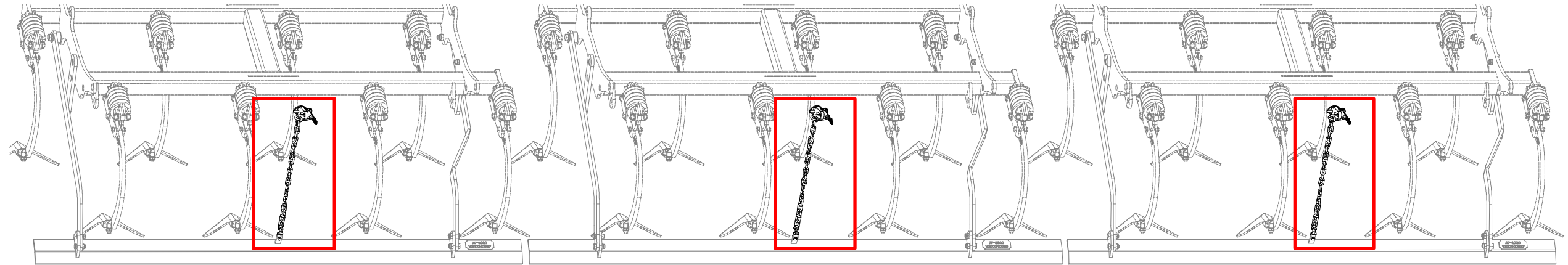

Pos.	Part Number	Pcs.
8	4001641	3
20	m01092	3
30	m04503	3
40	m01203	3

CZ SADA ZADNÍCH VÁLČŮ
 D SATZ HINTERE WALZEN
 F KIT DE ROULEAUX ARRIÈRE

GB SET OF REAR ROLLERS
 RU КОМПЛЕКТ ЗАДНИХ КАТКОВ
 PL ZESTAW TYLNYCH WAŁÓW



VZ00041903

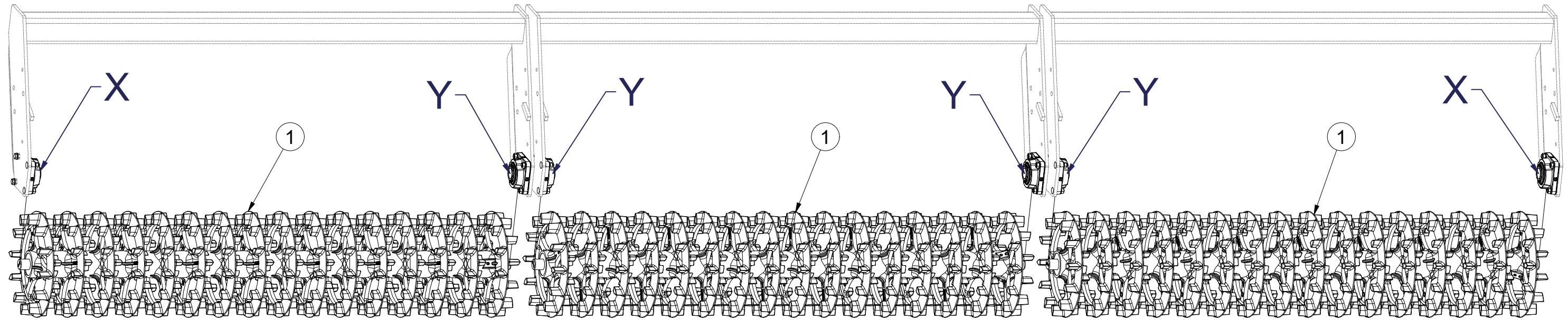

X

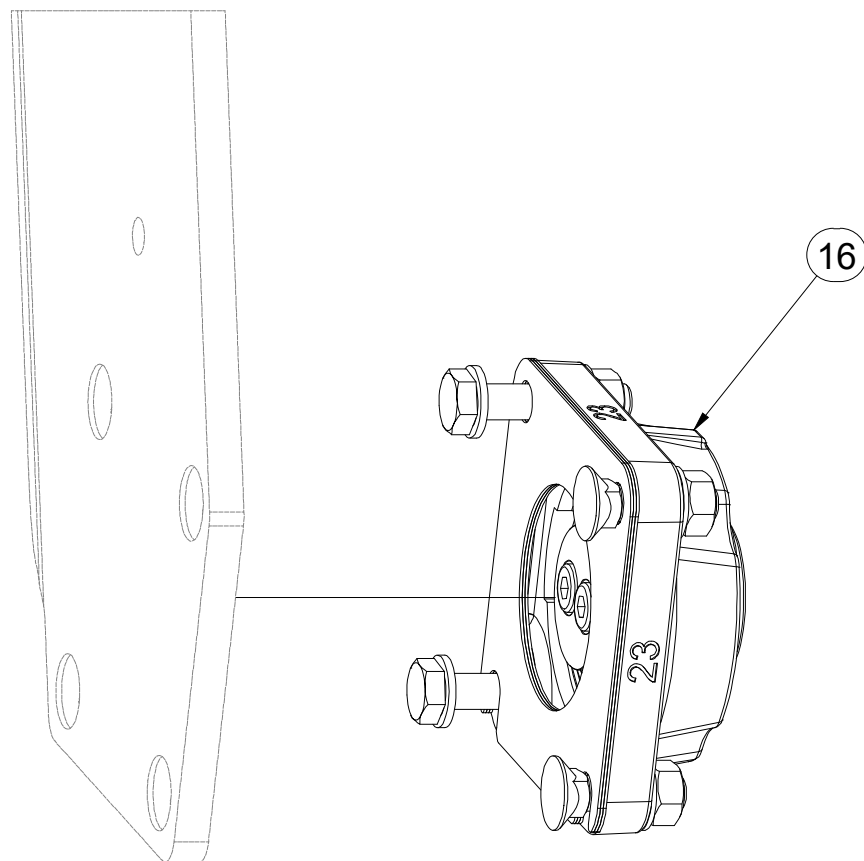

Y

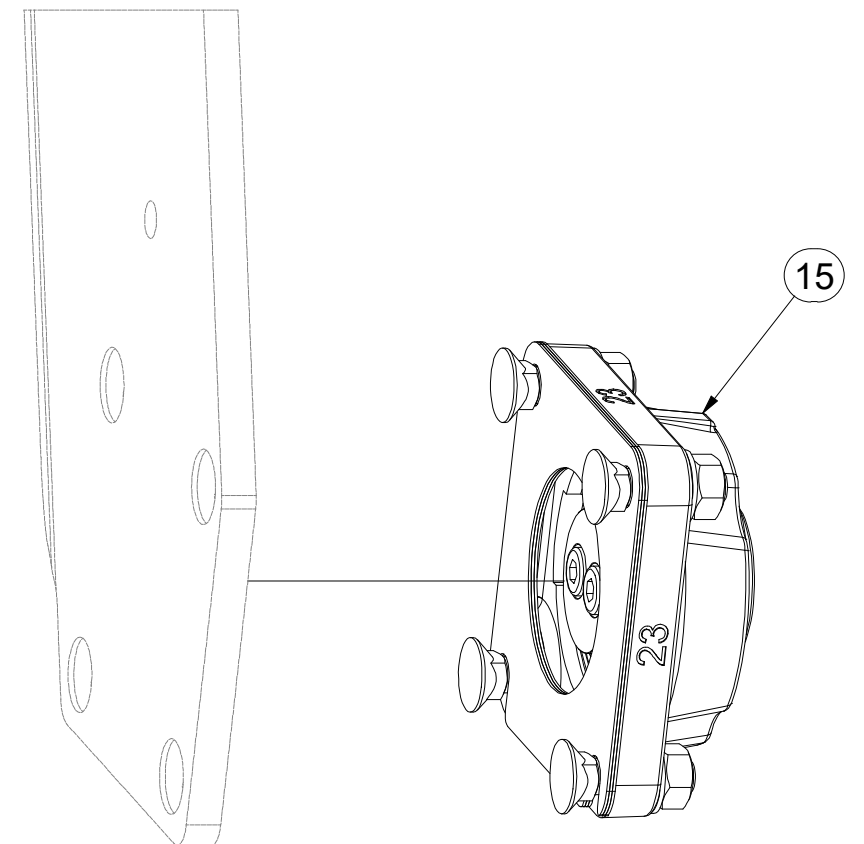

Pos.	Part Number	Pcs.
1	VZ00039892	3
15	VZ00038060	4
16	VZ00039819	2

Ⓒ SADA ZADNÍCH VÁLCŮ

Ⓓ SATZ HINTERE WALZEN

Ⓕ KIT DE ROULEAUX ARRIÈRE

VZ00039892

Ⓖ SET OF REAR ROLLERS

Ⓡ КОМПЛЕКТ ЗАДНИХ КАТКОВ

Ⓟ ZESTAW TYLNYCH WAŁÓW

Farmet

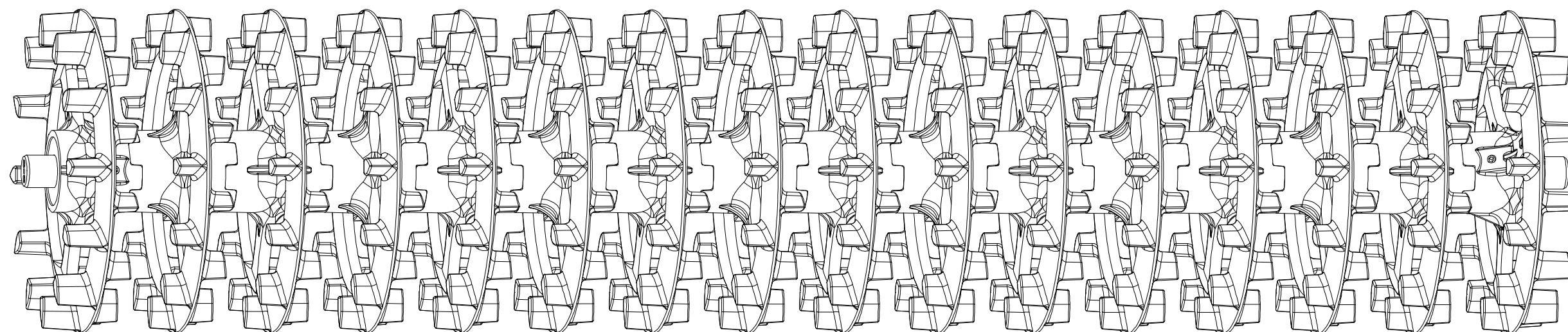

CZ SADA ZADNÍCH VÁLČŮ
 D SATZ HINTERE WALZEN
 F KIT DE ROULEAUX ARRIÈRE

GB SET OF REAR ROLLERS
 RU КОМПЛЕКТ ЗАДНИХ КАТКОВ
 PL ZESTAW TYLNYCH WAŁÓW



VZ00039892

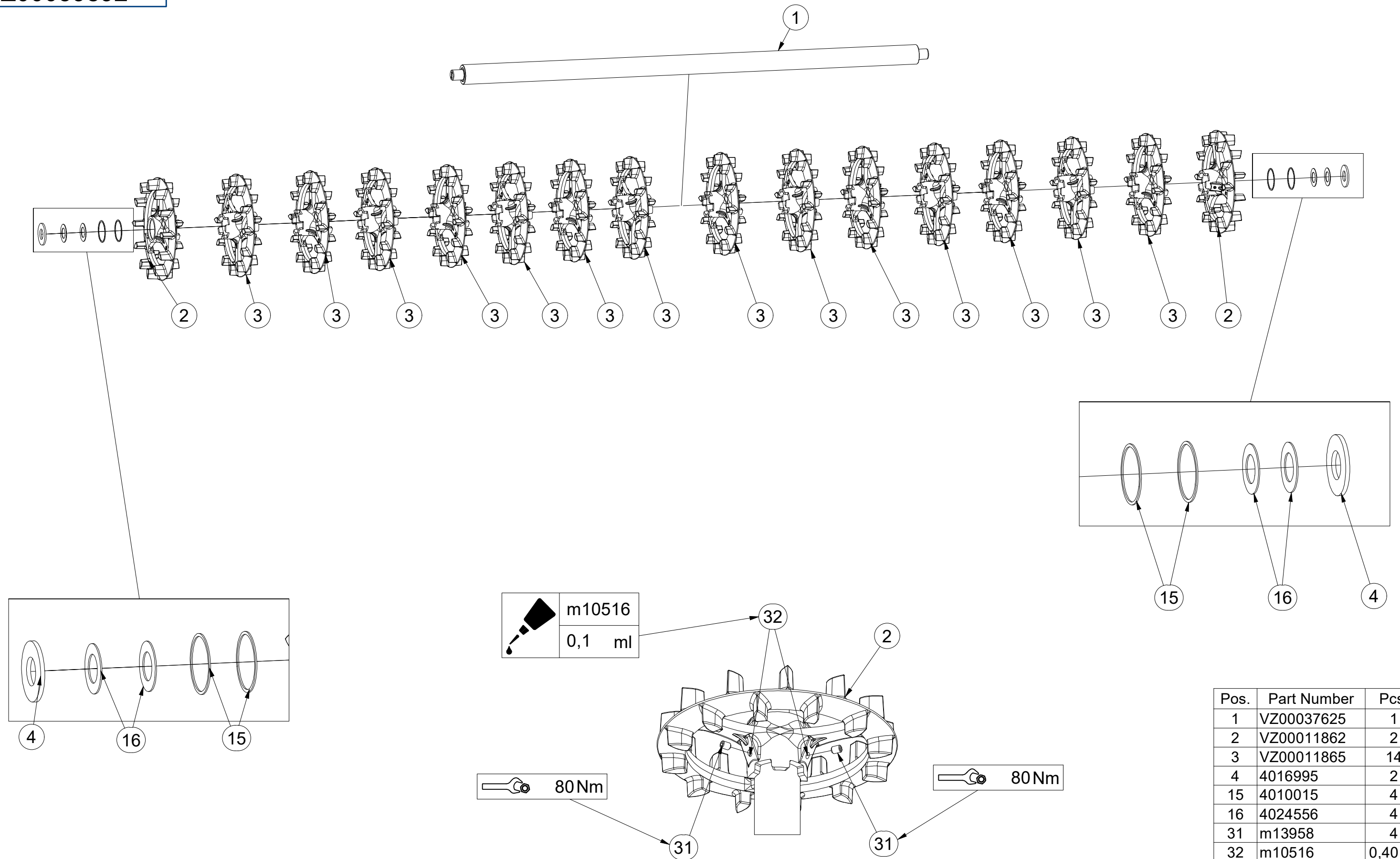

Pos.	Part Number	Pcs.
1	VZ00037625	1
2	VZ00011862	2
3	VZ00011865	14
4	4016995	2
15	4010015	4
16	4024556	4
31	m13958	4
32	m10516	0,40 ml

- Ⓒ SMYKY ZADNÍCH VÁLCŮ
- Ⓓ SCHLEIFE HINTERE WALZE
- Ⓕ NIVELEUR ARRIÈRE ROULEAUX

- Ⓖ REAR ROLLERS LEVELLERS
- Ⓡ БОРОНЫ ЗАДНИХ КАТКОВ
- Ⓟ WŁÓKY TYLNYCH WAŁOW



VZ00041904

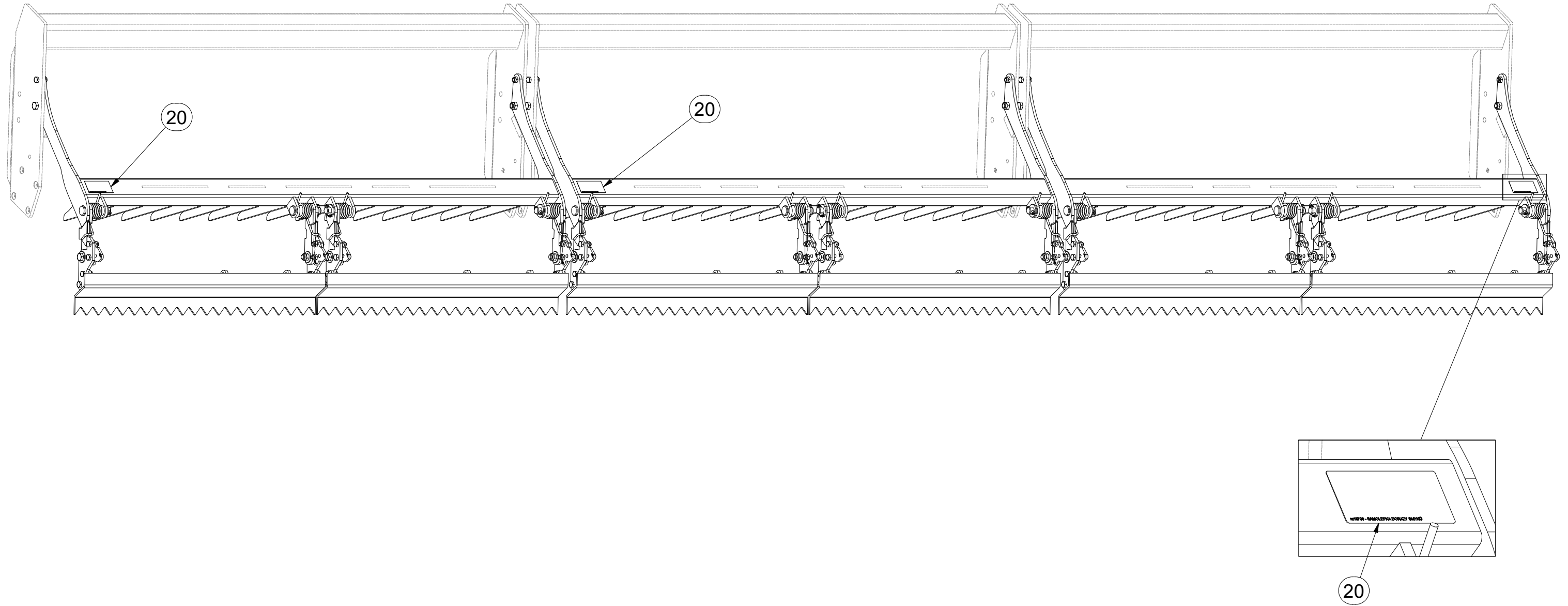

Pos.	Part Number	Pcs.
20	m13708	3

CZ SADA LOŽISEK
 D SATZ LAGER
 F KIT DE ROULEMENTS

GB SET OF BEARINGS
 RU КОМПЛЕКТ ПОДШИПНИКОВ
 PL ZESTAW ŁOŻYSK



VZ00038060

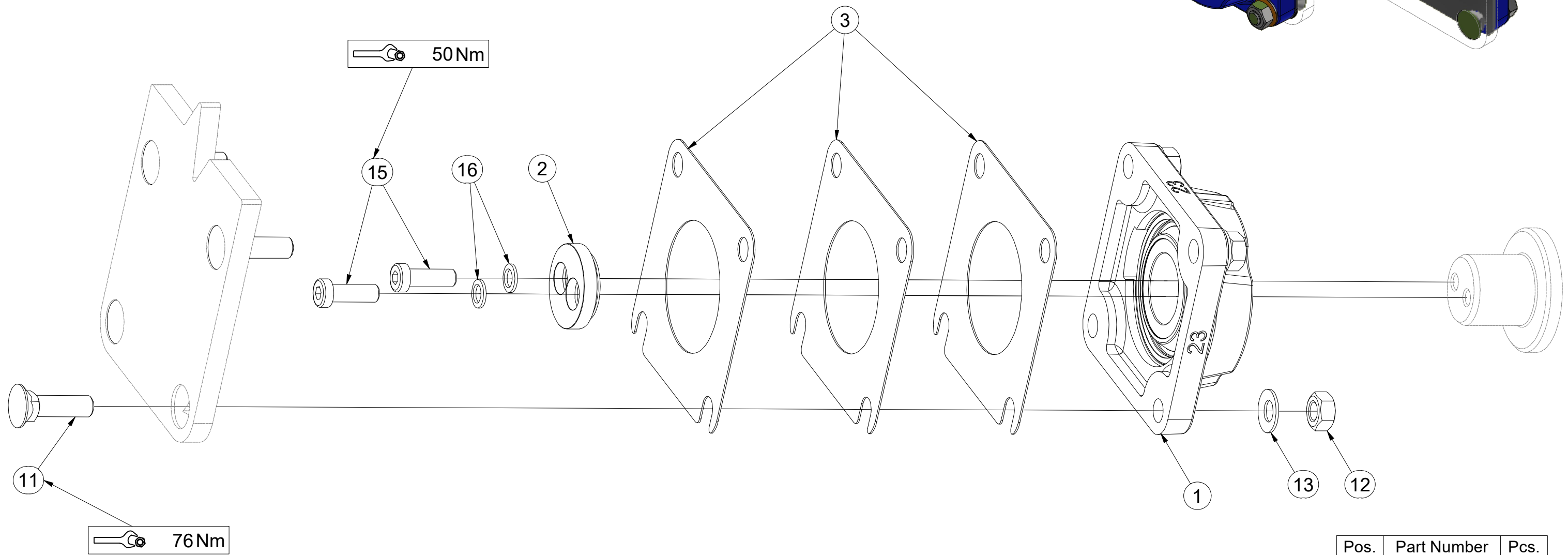
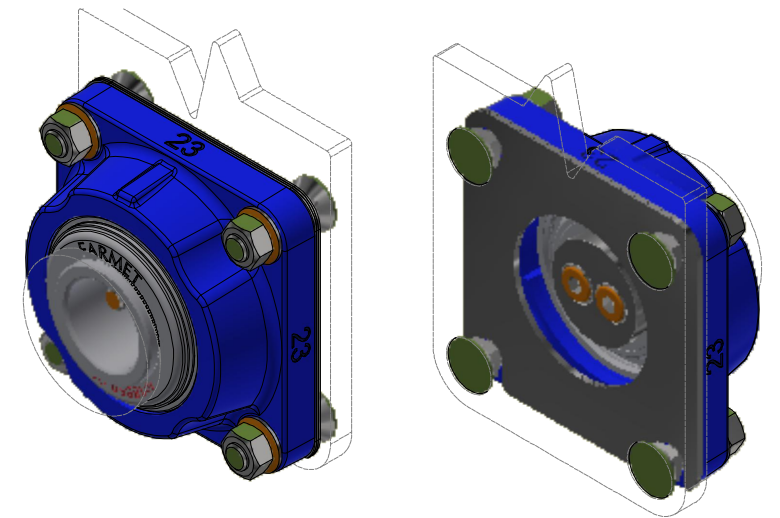

Pos.	Part Number	Pcs.
1	m18650-23	1
2	VZ00038211	1
3	4016809	3
11	m03519	4
12	m01305	4
13	m17545	4
15	m24320	2
16	m24356	2

CZ SADA LOŽISEK
 D SATZ LAGER
 F KIT DE ROULEMENTS

GB SET OF BEARINGS
 RU КОМПЛЕКТ ПОДШИПНИКОВ
 PL ZESTAW ŁOŻYSK



VZ00039819

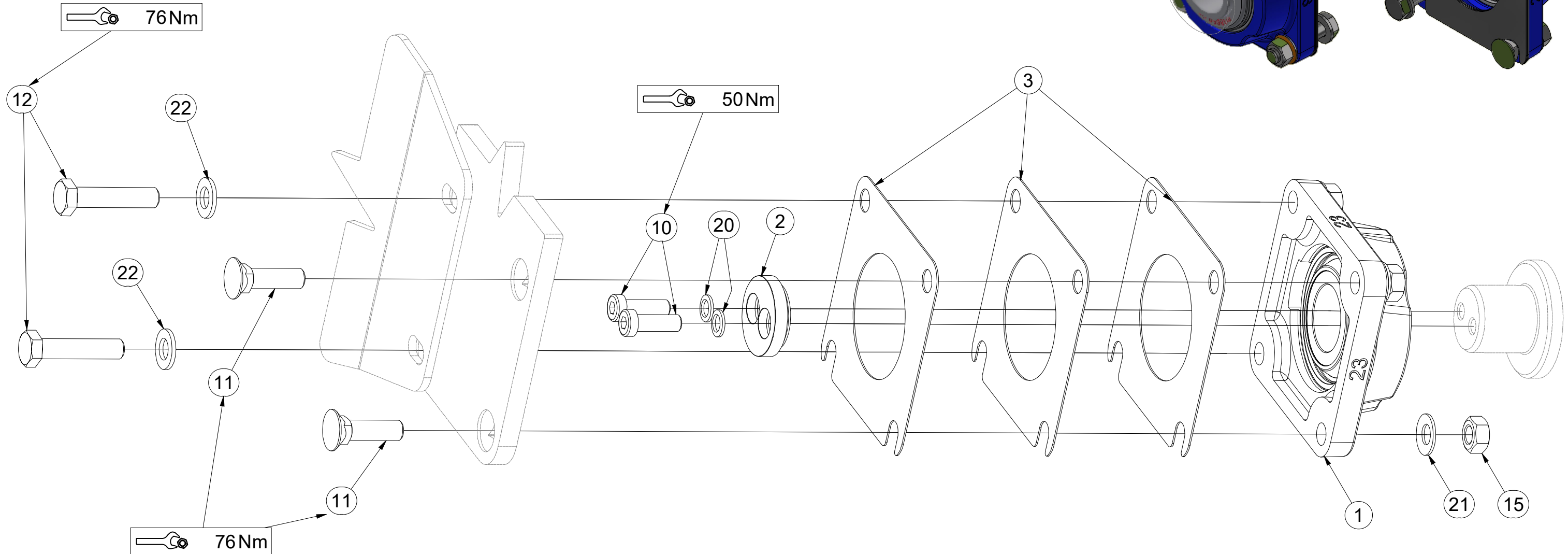
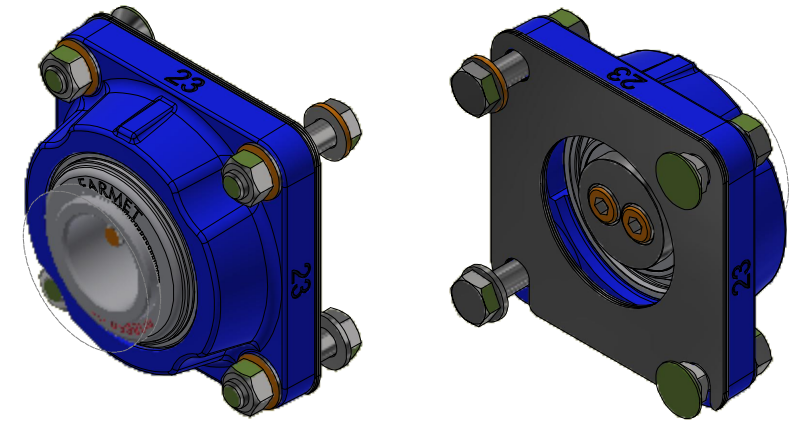

Pos.	Part Number	Pcs.
1	m18650-23	1
2	VZ00038211	1
3	4016809	3
10	m24320	2
11	m03519	2
12	m04412	2
15	m01305	4
20	m24356	2
21	m17545	4
22	m17741	2

VZ00038564

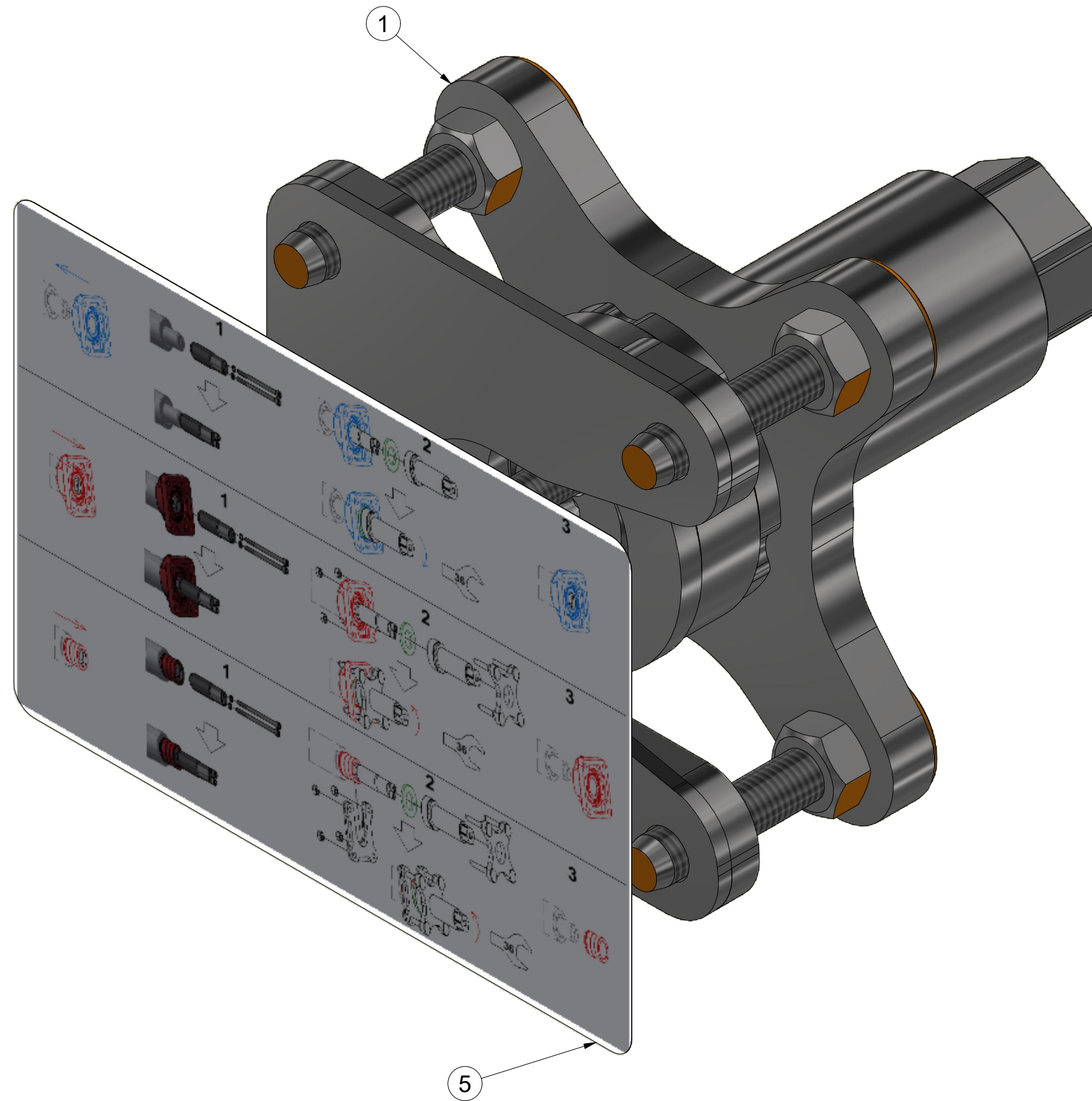

Pos.	Part Number	Pcs.
1	VZ00040530	1
5	m24596	1

VZ00040530

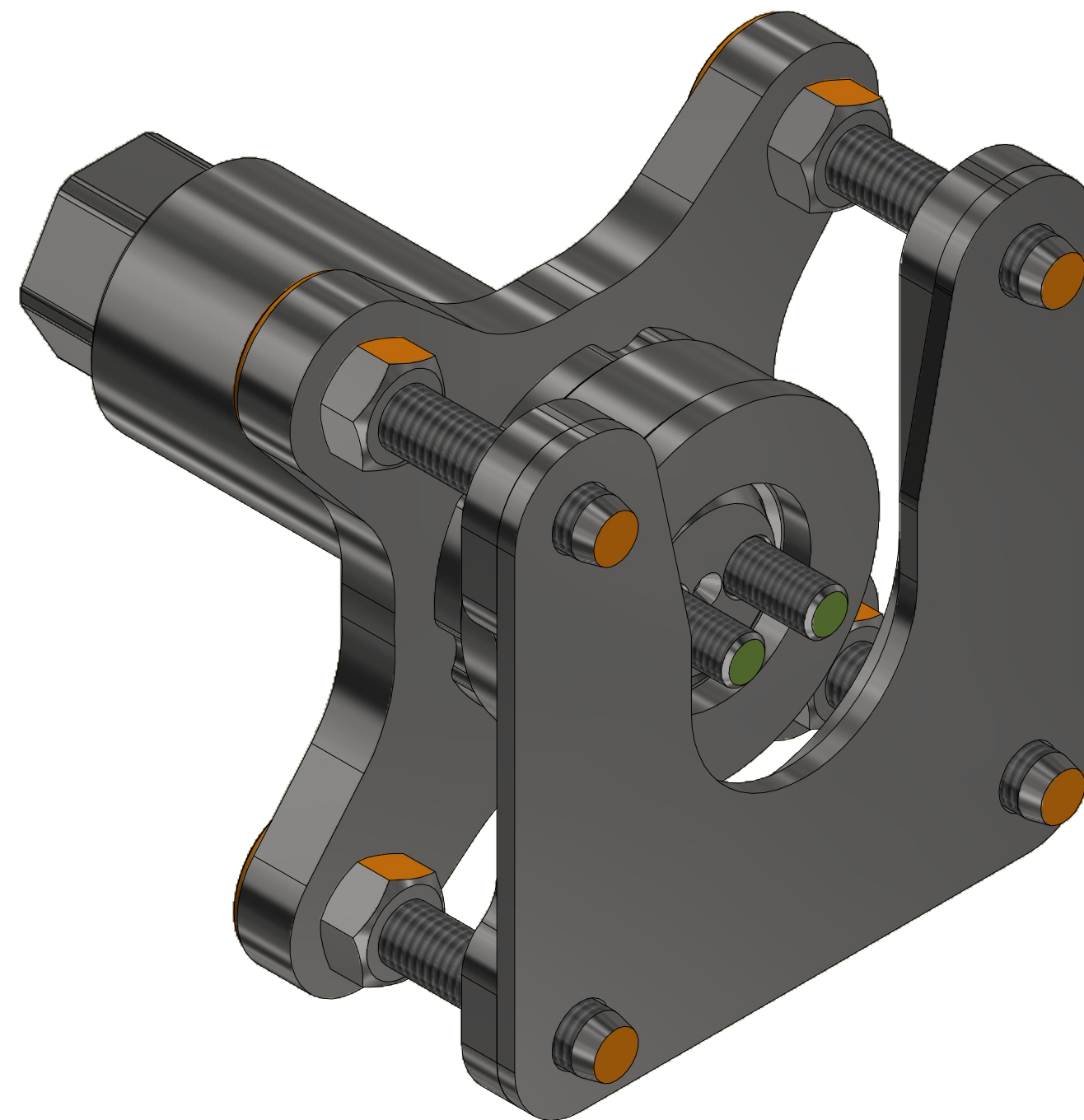
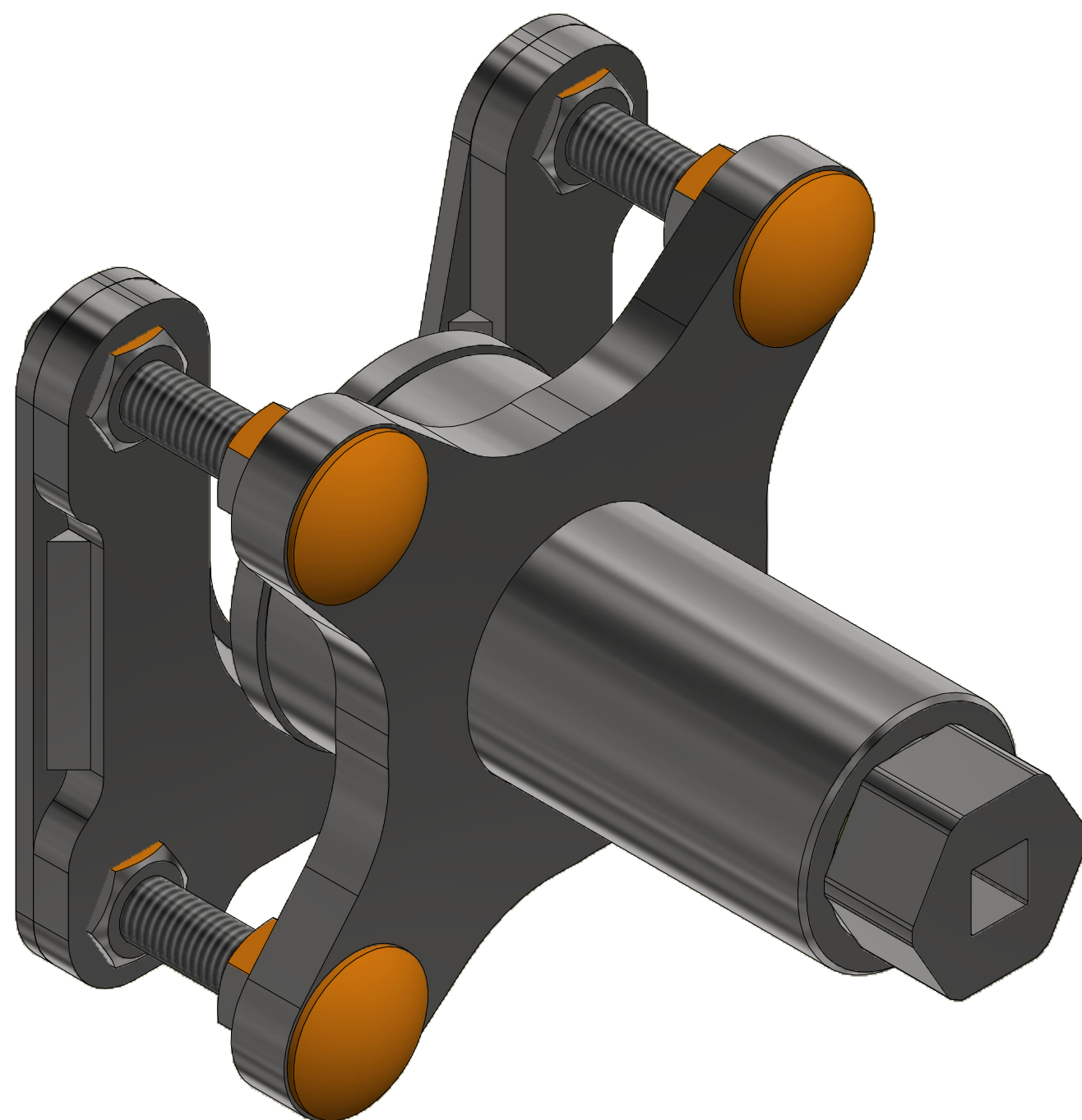

VZ00040530

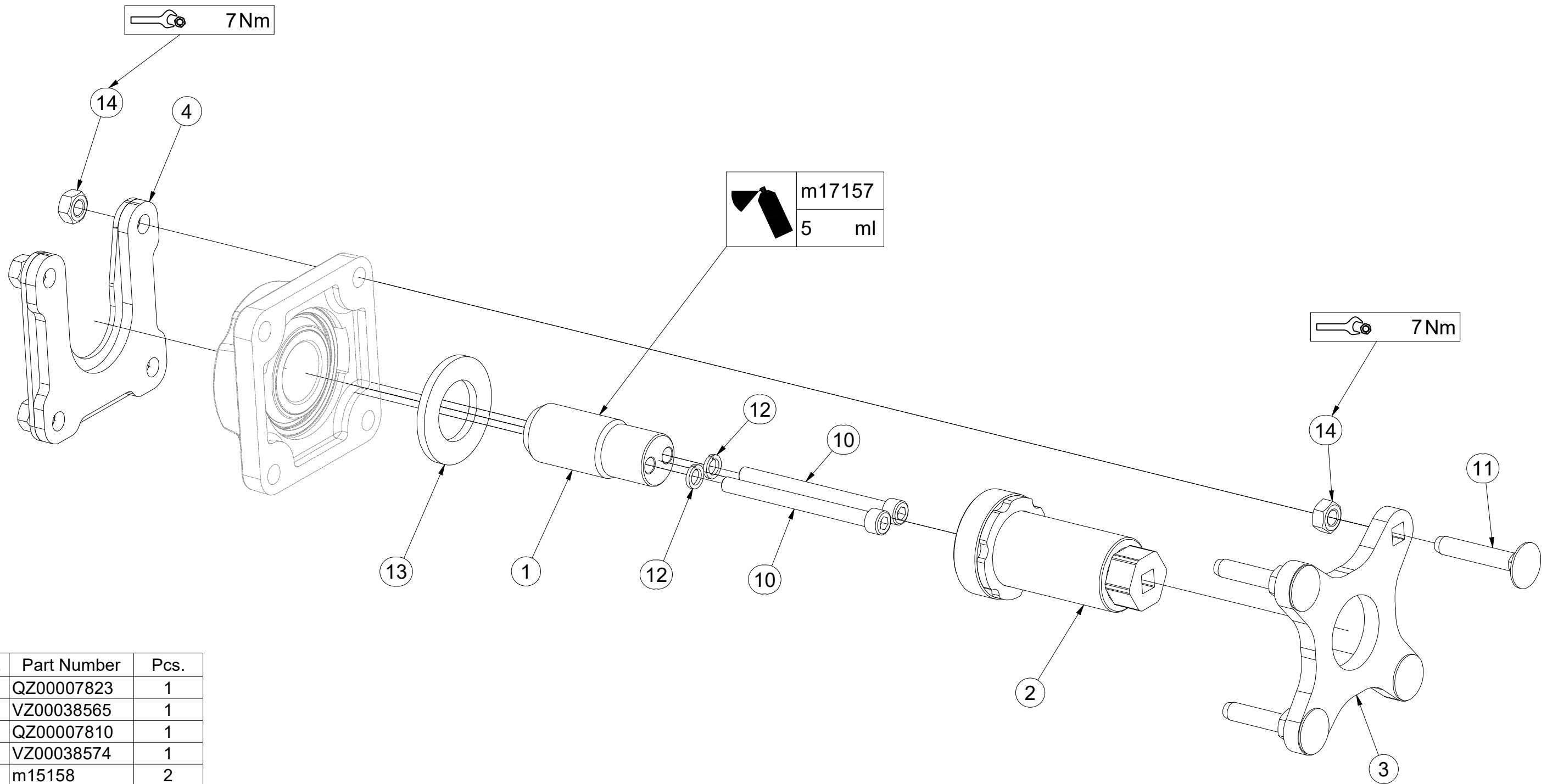

Pos.	Part Number	Pcs.
1	QZ00007823	1
2	VZ00038565	1
3	QZ00007810	1
4	VZ00038574	1
10	m15158	2
11	m17684	4
12	m01208	2
13	m03636	1
14	m10439	8
20	m17157	5,00 ml

CZ SMYKY ZADNÍCH VÁLCŮ
 D SCHLEIFE HINTERE WALZE
 F NIVELEUR ARRIÈRE ROULEAUX

GB REAR ROLLERS LEVELLERS
 RU БОРОНЫ ЗАДНИХ КАТКОВ
 PL WŁÓKY TYLNYCH WAŁOW



VZ00041904

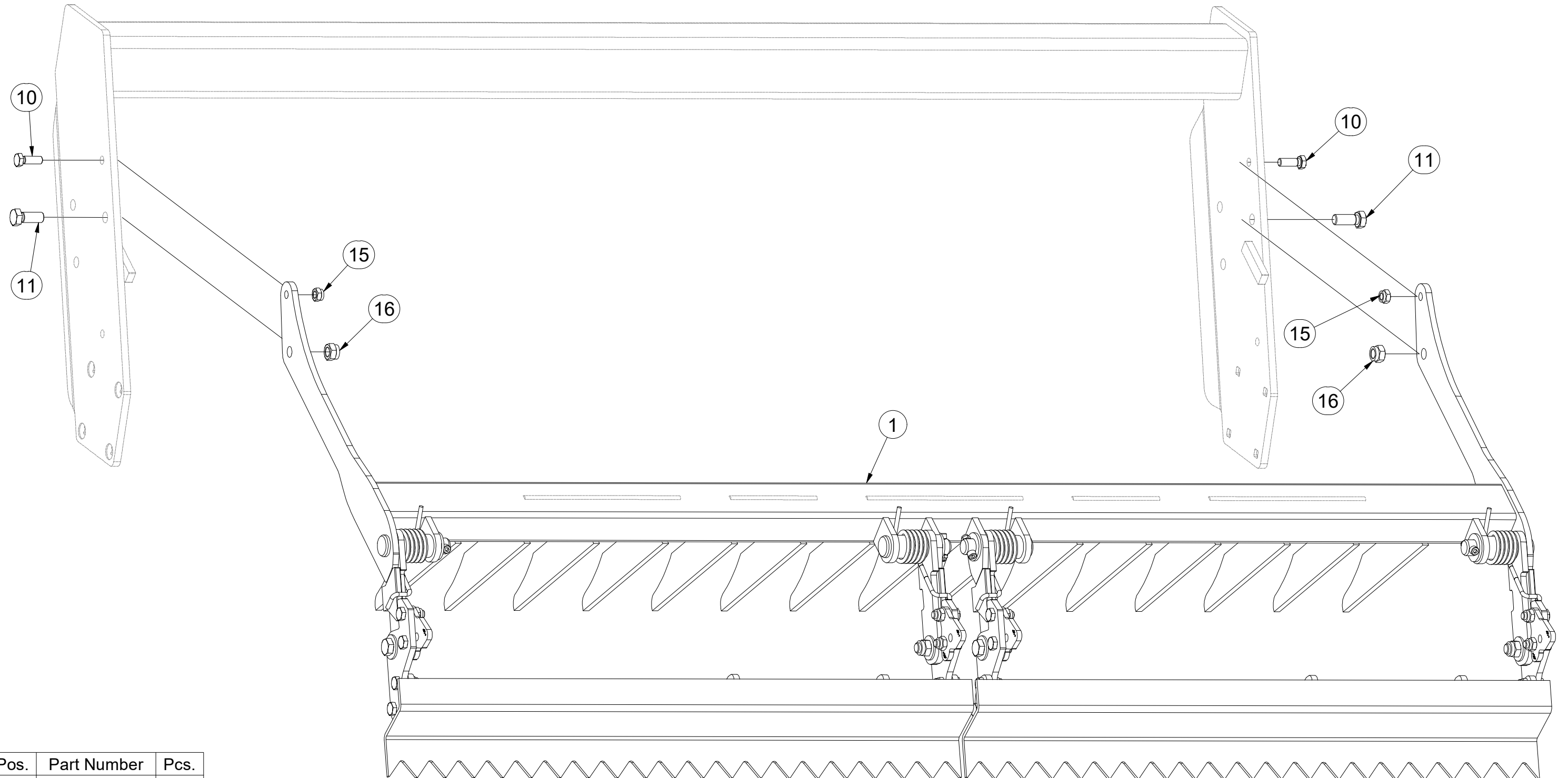

Pos.	Part Number	Pcs.
1	VZ00041675	3
10	m04343	6
11	m01129	6
15	m04301	6
16	m03683	6

ⒸZ SMYKY ZADNÍCH VÁLCŮ

Ⓓ SCHLEIFE HINTERE WALZE

Ⓕ NIVELEUR ARRIÈRE ROULEAUX

VZ00041675

ⒸGB REAR ROLLERS LEVELLERS

ⒸRU БОРОНЫ ЗАДНИХ КАТКОВ

ⒸPL WŁÓKY TYLNYCH WAŁÓW

Farmet

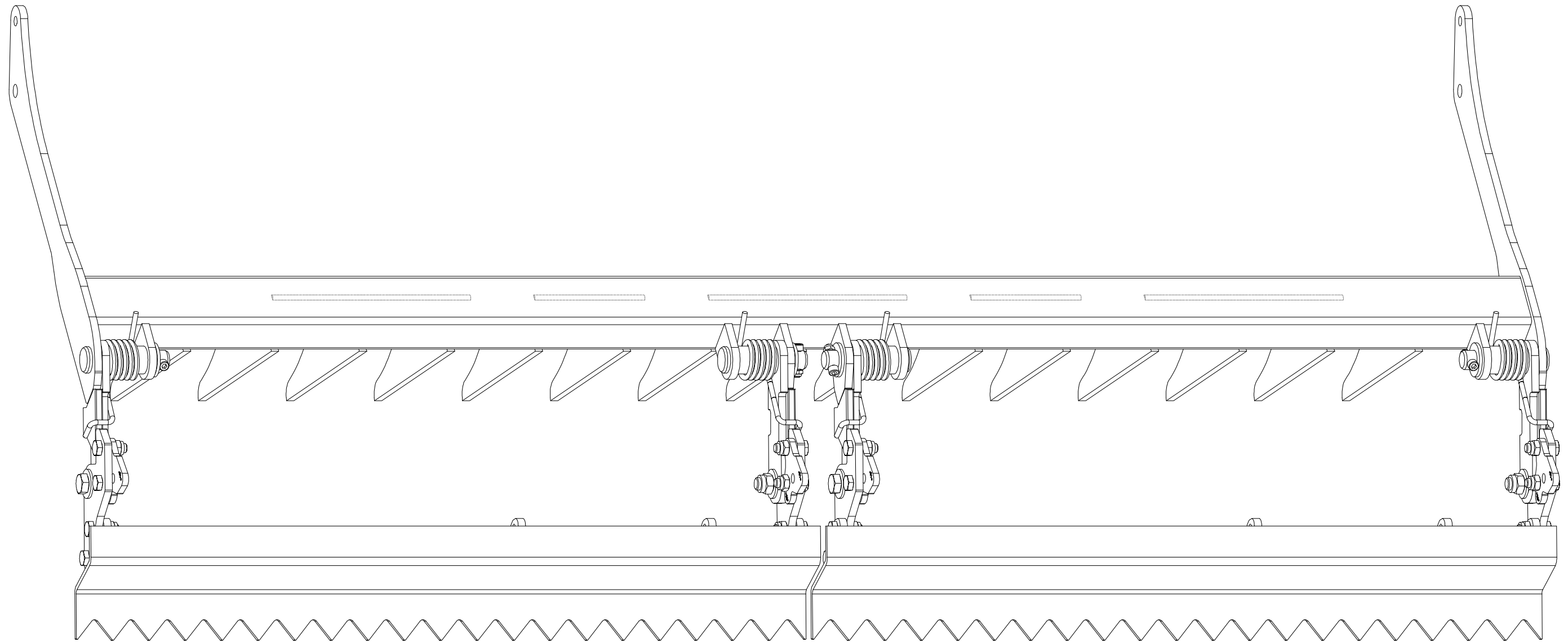

CZ SMYKY ZADNÍCH VÁLCŮ
 D SCHLEIFE HINTERE WALZE
 F NIVELEUR ARRIÈRE ROULEAUX

GB REAR ROLLERS LEVELLERS
 RU БОРОНЫ ЗАДНИХ КАТКОВ
 PL WŁÓKY TYLNYCH WAŁOW



VZ00041675

Pos.	Part Number	Pcs.
10	VZ00038536	4
21	m04343	8
31	m04301	8

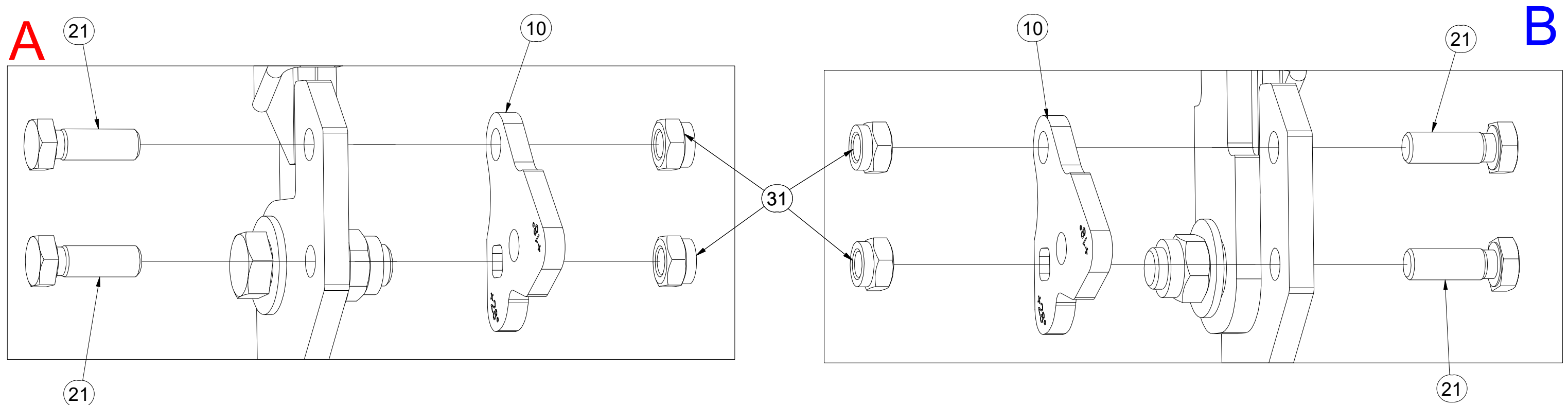
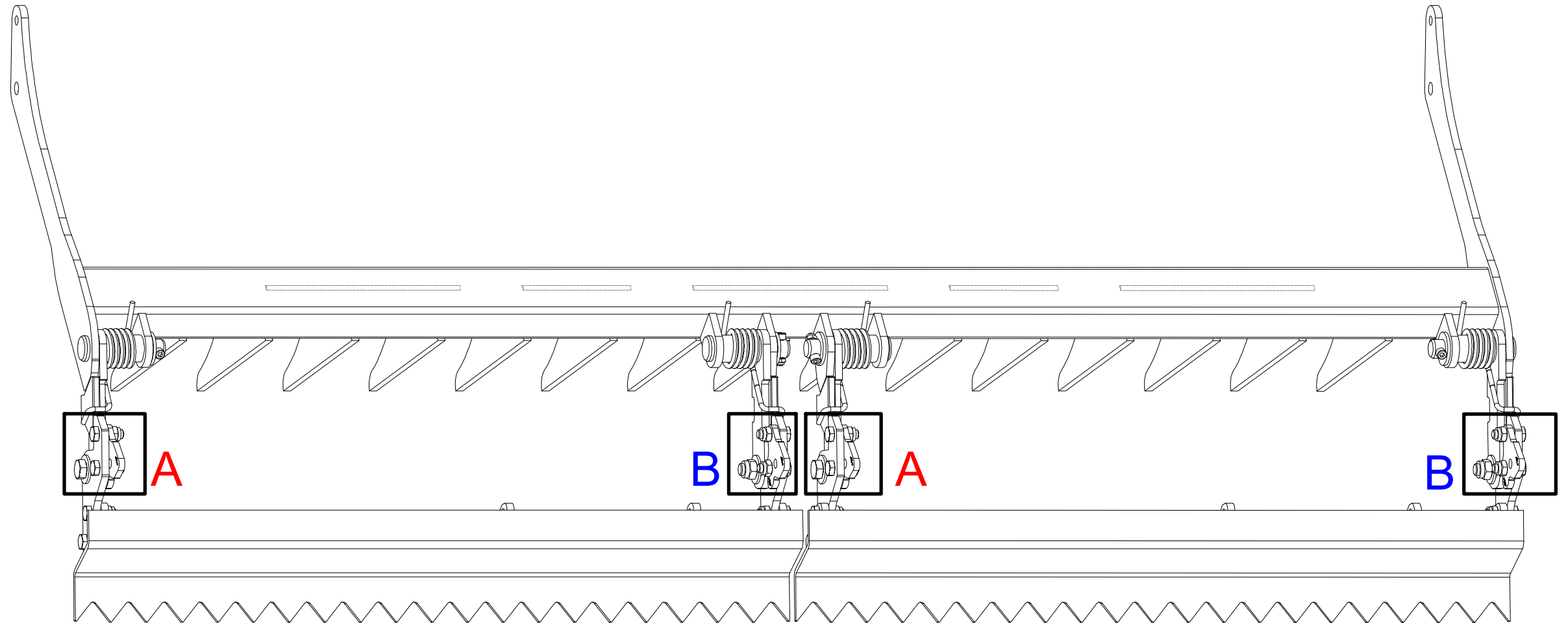

Ⓒ SMYK

Ⓓ ACKERSCHLEIFE

Ⓕ NIVELEUR

Ⓖ LEVELLER

Ⓡ БОРОНА

Ⓟ WŁÓKA



VZ00034296

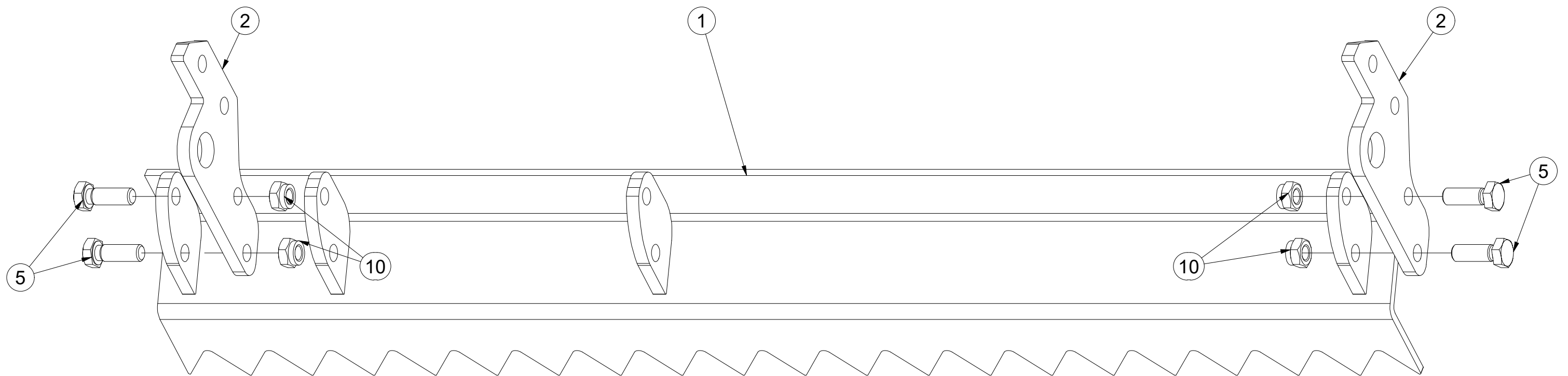

Pos.	Part Number	Pcs.
1	VZ00034293	1
2	VZ00014941	2
5	m04343	4
10	m04301	4

Ⓒ SMYK

Ⓓ ACKERSCHLEIFE

Ⓕ NIVELEUR

Ⓖ LEVELLER

Ⓡ БОРОНА

Ⓟ WŁÓKA



VZ00034297

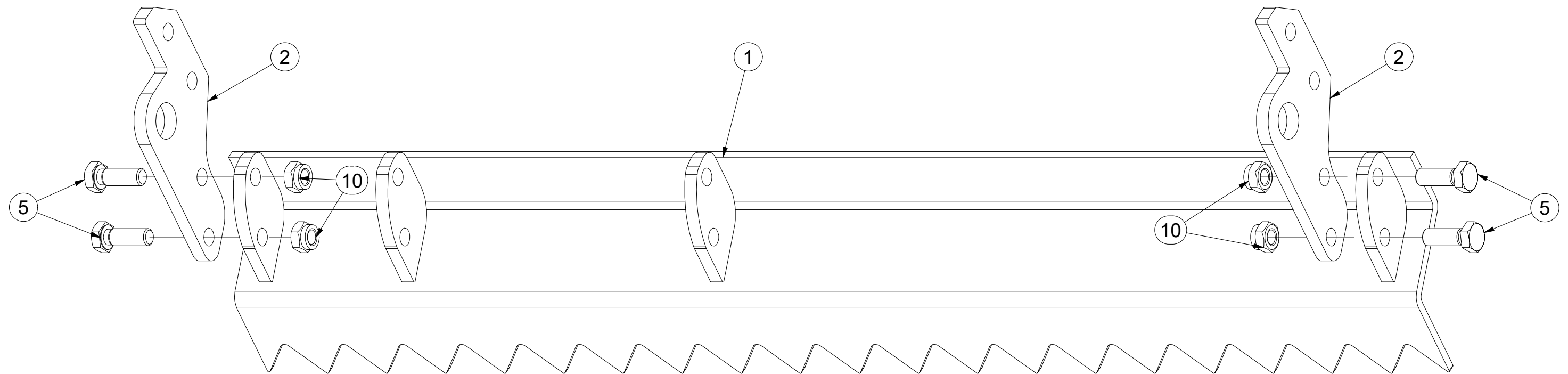

Pos.	Part Number	Pcs.
1	VZ00034293	1
2	VZ00014941	2
5	m04343	4
10	m04301	4

Ⓒ SADA NÁPRAVY

Ⓓ SATZ AUFHÄNGUNG

Ⓕ KIT DE L'ESSIEU

Ⓖ AXLE SET

Ⓡ КОМПЛЕКТ ОСИ КОЛЁС

Ⓟ ZESTAW OSI



3012415

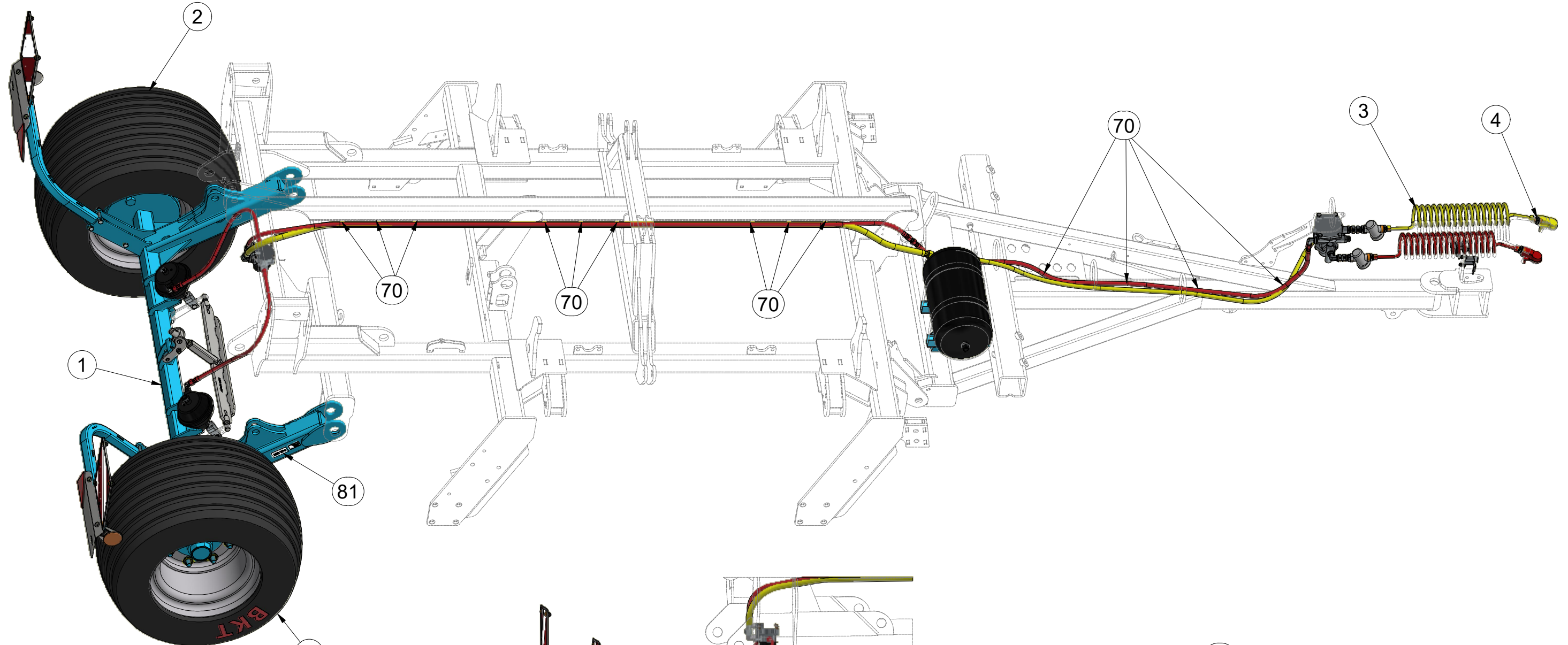

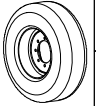
	280 kPa
	M20x1,5-343Nm

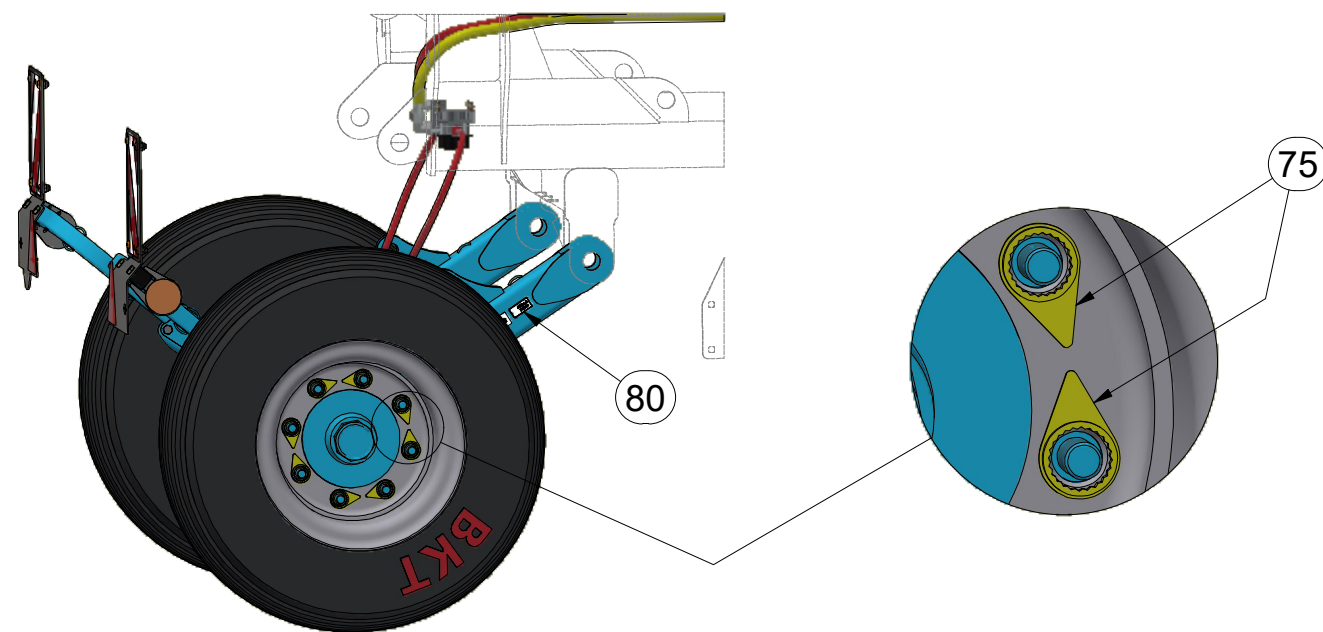

Pos.	Part Number	Pcs.
1	3012421	1
2	m21353	2
3	m18910	1
4	m19041	1
70	m05566	30
75	m19658	16
80	m19731	2
81	m21945	2

Ⓒ SADA NÁPRAVY

Ⓓ SATZ AUFHÄNGUNG

Ⓕ KIT DE L'ESSIEU

Ⓖ AXLE SET

Ⓡ КОМПЛЕКТ ОСИ КОЛЁС

Ⓟ ZESTAW OSI



3012415

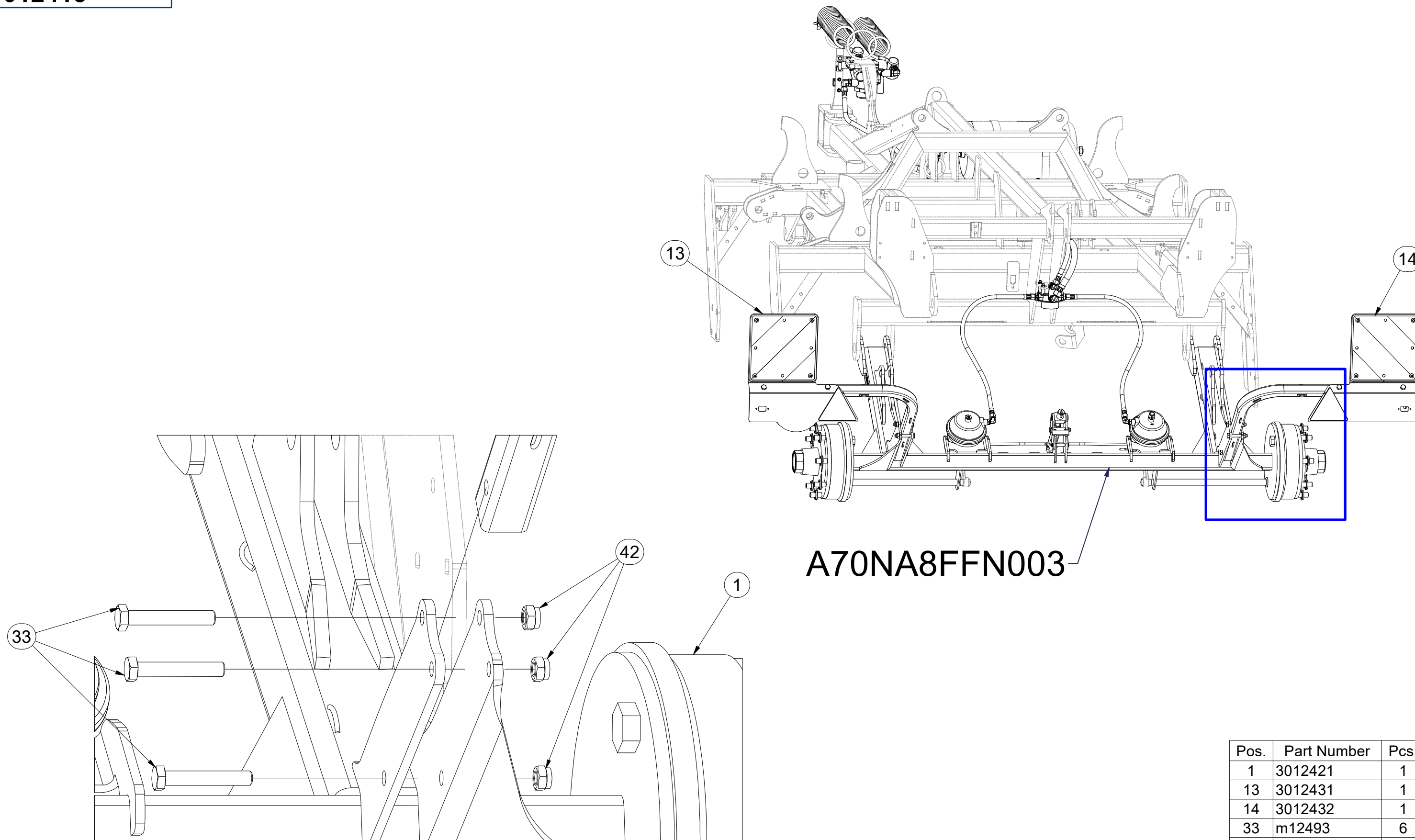

Pos.	Part Number	Pcs.
1	3012421	1
13	3012431	1
14	3012432	1
33	m12493	6
42	m04301	8

CZ SADA NÁPRAVY
 D SATZ AUFHÄNGUNG
 F KIT DE L'ESSIEU

GB AXLE SET
 RU КОМПЛЕКТ ОСИ КОЛЁС
 PL ZESTAW OSI



3012415

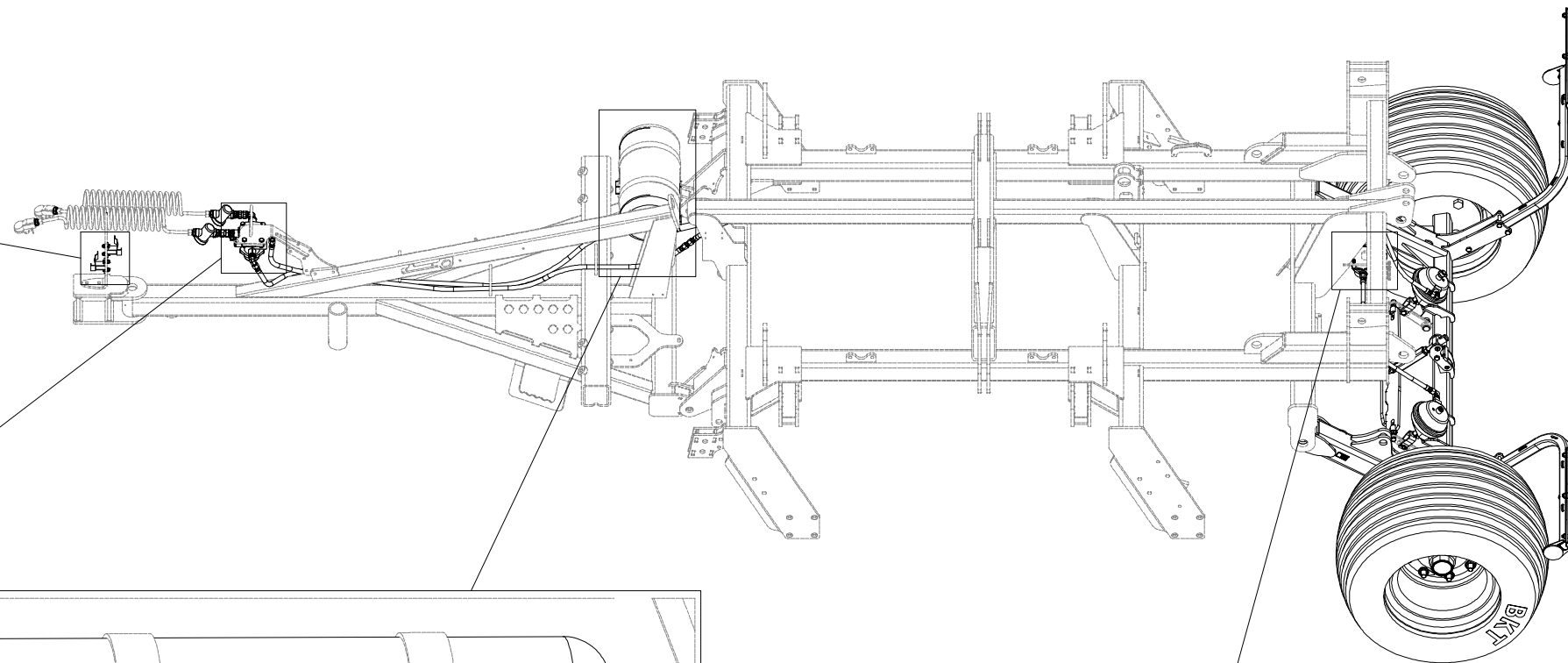
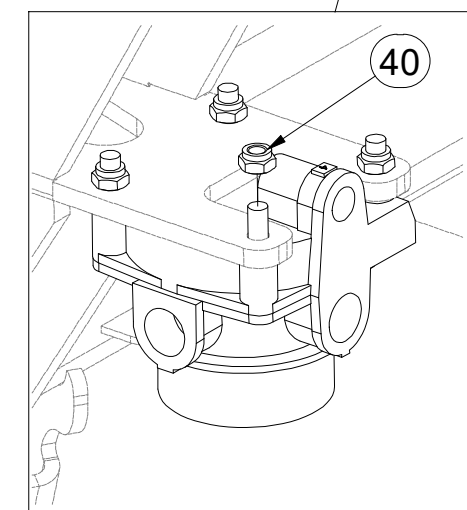
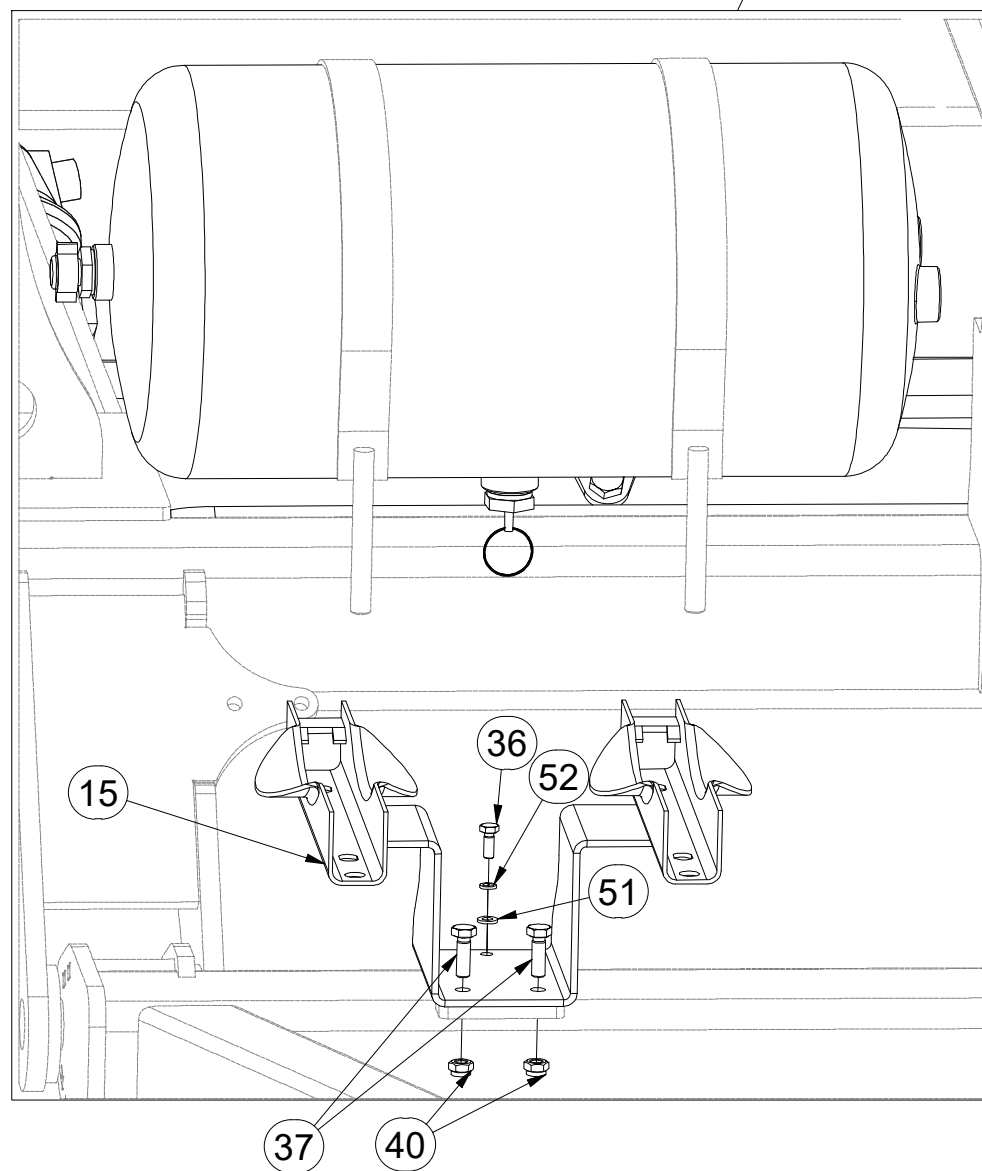
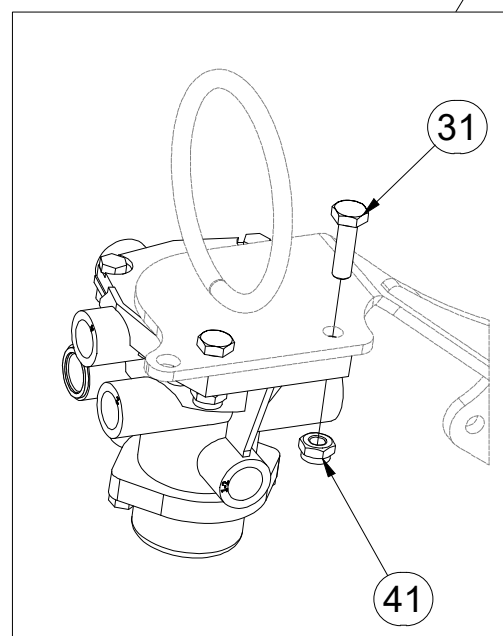
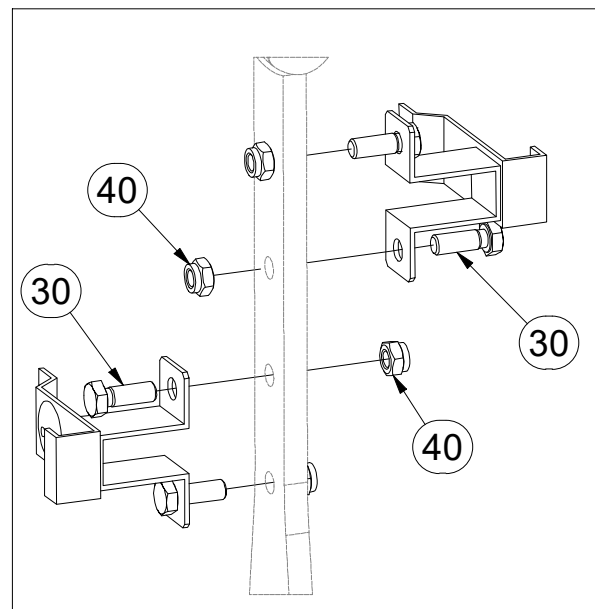

Pos.	Part Number	Pcs.	Pos.	Part Number	Pcs.
15	3012474	1	40	m04503	10
30	m01090	4	41	m03775	2
31	m04613	2	51	m01199	1
36	m01073	1	52	m01200	1
37	m01092	2			

CZ SADA NÁPRAVY
 D SATZ AUFHÄNGUNG
 F KIT DE L'ESSIEU

GB AXLE SET
 RU КОМПЛЕКТ ОСИ КОЛЁС
 PL ZESTAW OSI



3012415

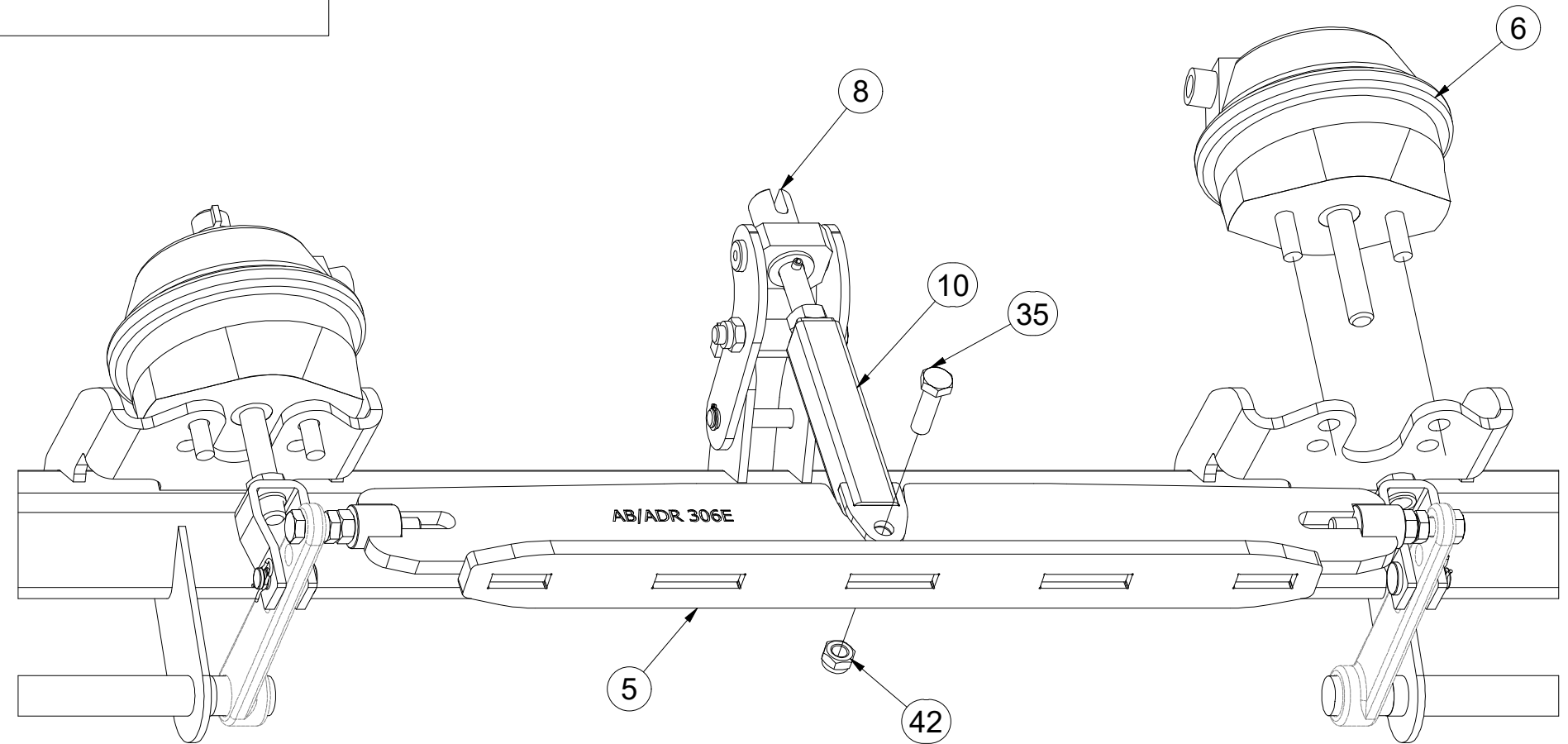
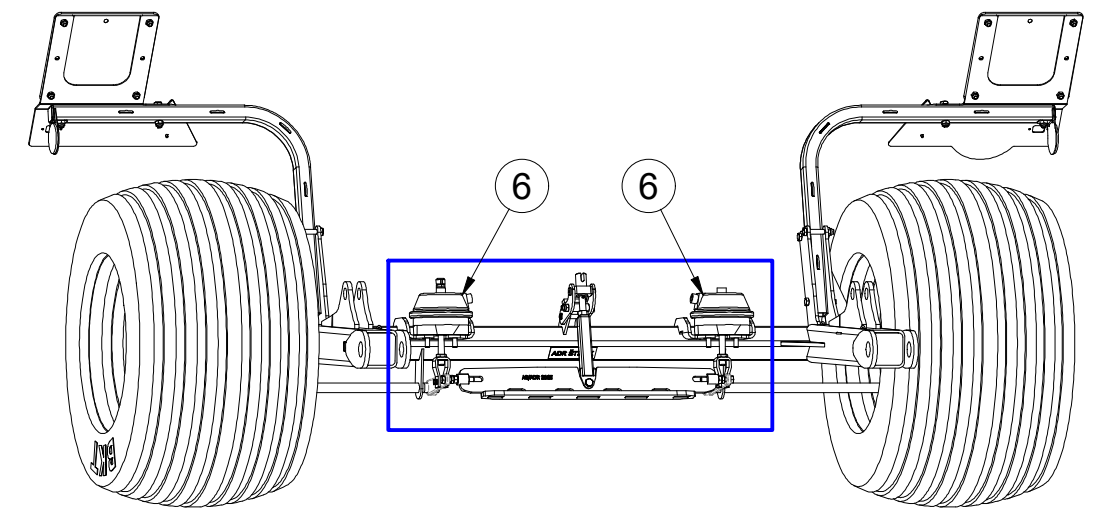
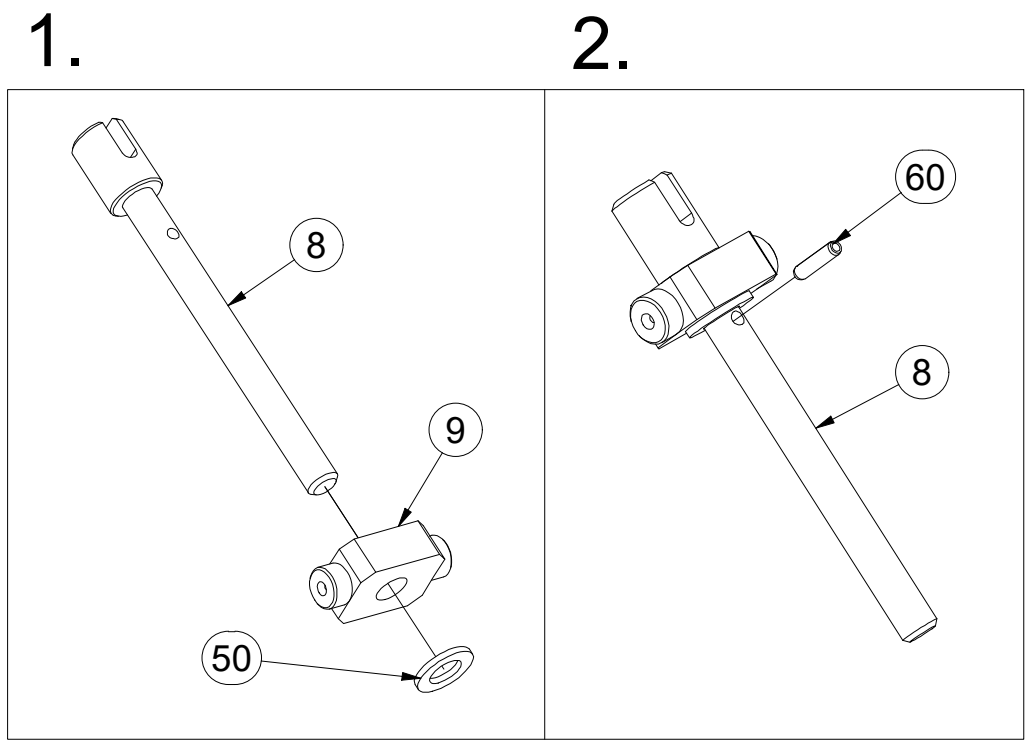

Pos.	Part Number	Pcs.
5	4026182	1
6	4025207	2
8	4008114	1
9	4004806	1
10	3002657	1
35	m03926	1
42	m04301	8
50	m01219	1
60	m11505	1

Ⓒ SADA NÁPRAVY

Ⓓ SATZ AUFHÄNGUNG

Ⓕ KIT DE L'ESSIEU

Ⓖ AXLE SET

Ⓡ КОМПЛЕКТ ОСИ КОЛЁС

Ⓟ ZESTAW OSI



3012415

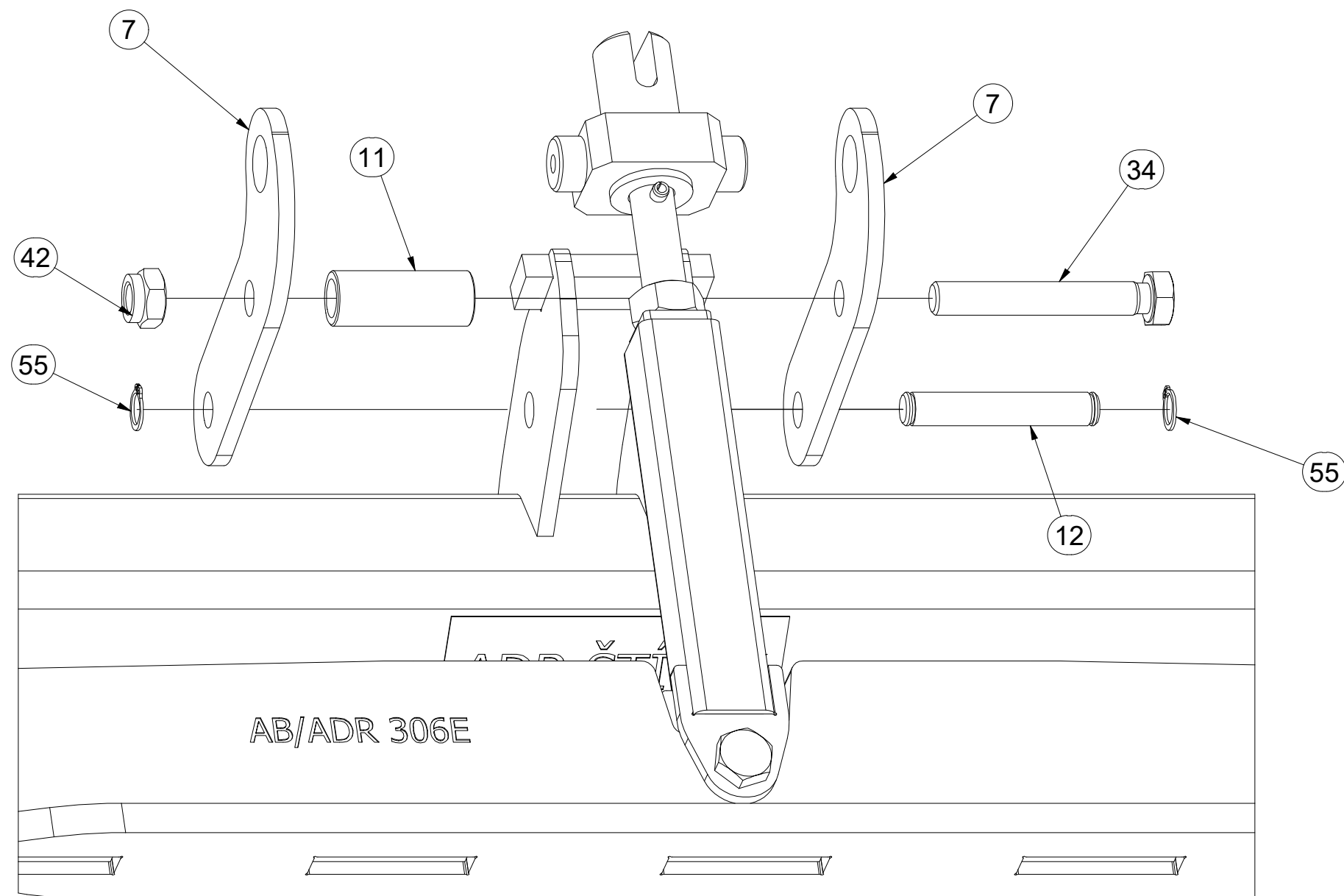
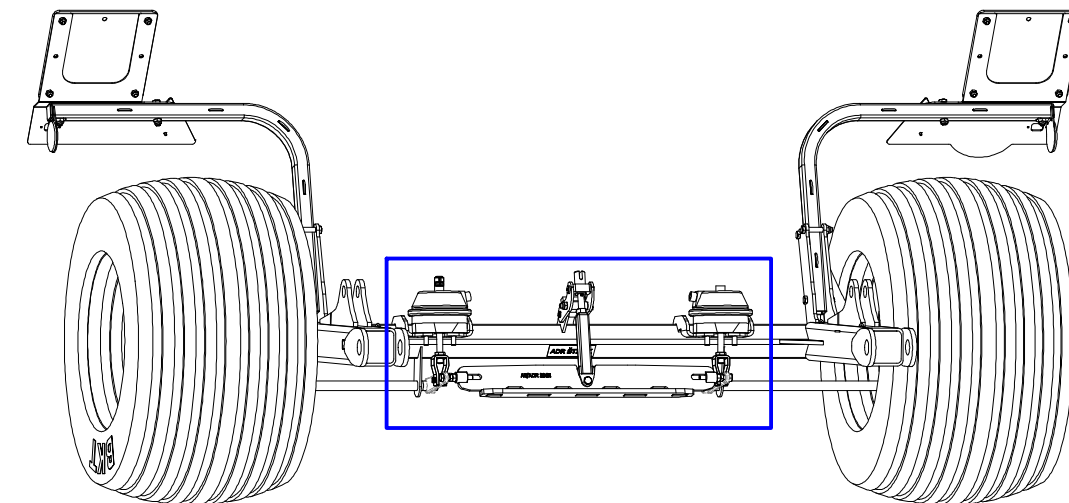

Pos.	Part Number	Pcs.
7	4004804	2
11	4004808	1
12	4021912	1
34	m06446	1
42	m04301	8
55	m18357	2

Ⓒ SADA NÁPRAVY

Ⓓ SATZ AUFHÄNGUNG

Ⓕ KIT DE L'ESSIEU

Ⓖ AXLE SET

Ⓡ КОМПЛЕКТ ОСИ КОЛЁС

Ⓢ ZESTAW OSI



3012415

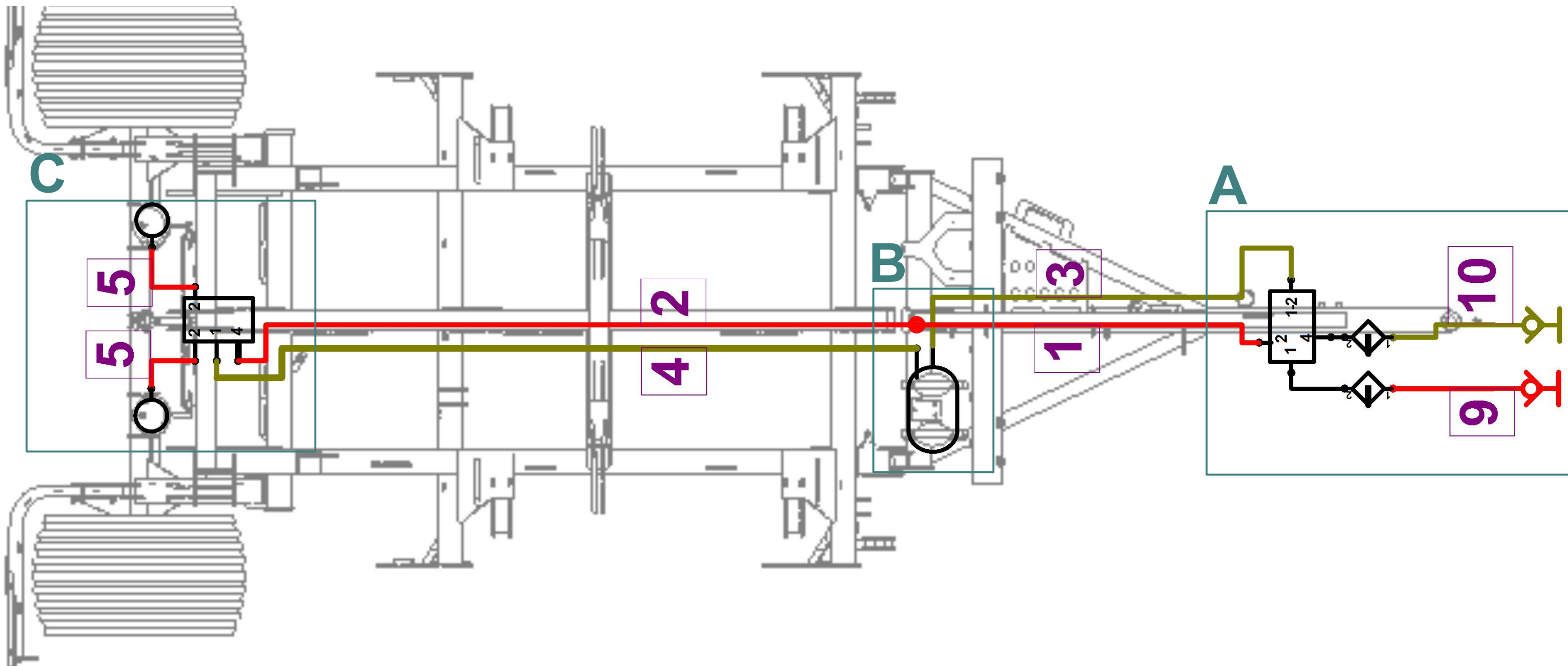

m19041

Pos.	Part Number	Pcs.
1	m18886	1
2	m18795	1
3	m18911	1
4	m18914	1
5	m18879	2

m18910

Pos.	Part Number	Pcs.
9	m09949	1
10	m09948	1

- Ⓒ SADA NÁPRAVY
- Ⓓ SATZ AUFHÄNGUNG
- Ⓕ KIT DE L'ESSIEU

- Ⓖ AXLE SET
- Ⓡ КОМПЛЕКТ ОСИ КОЛЁС
- Ⓟ ZESTAW OSI



m18910

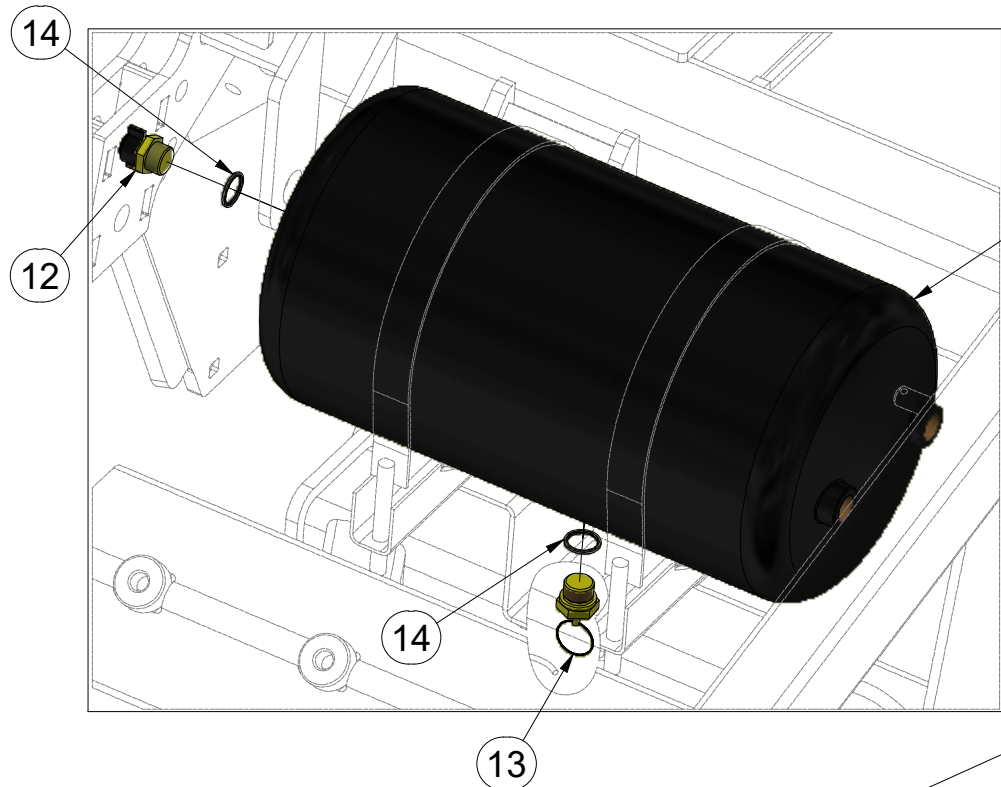

B

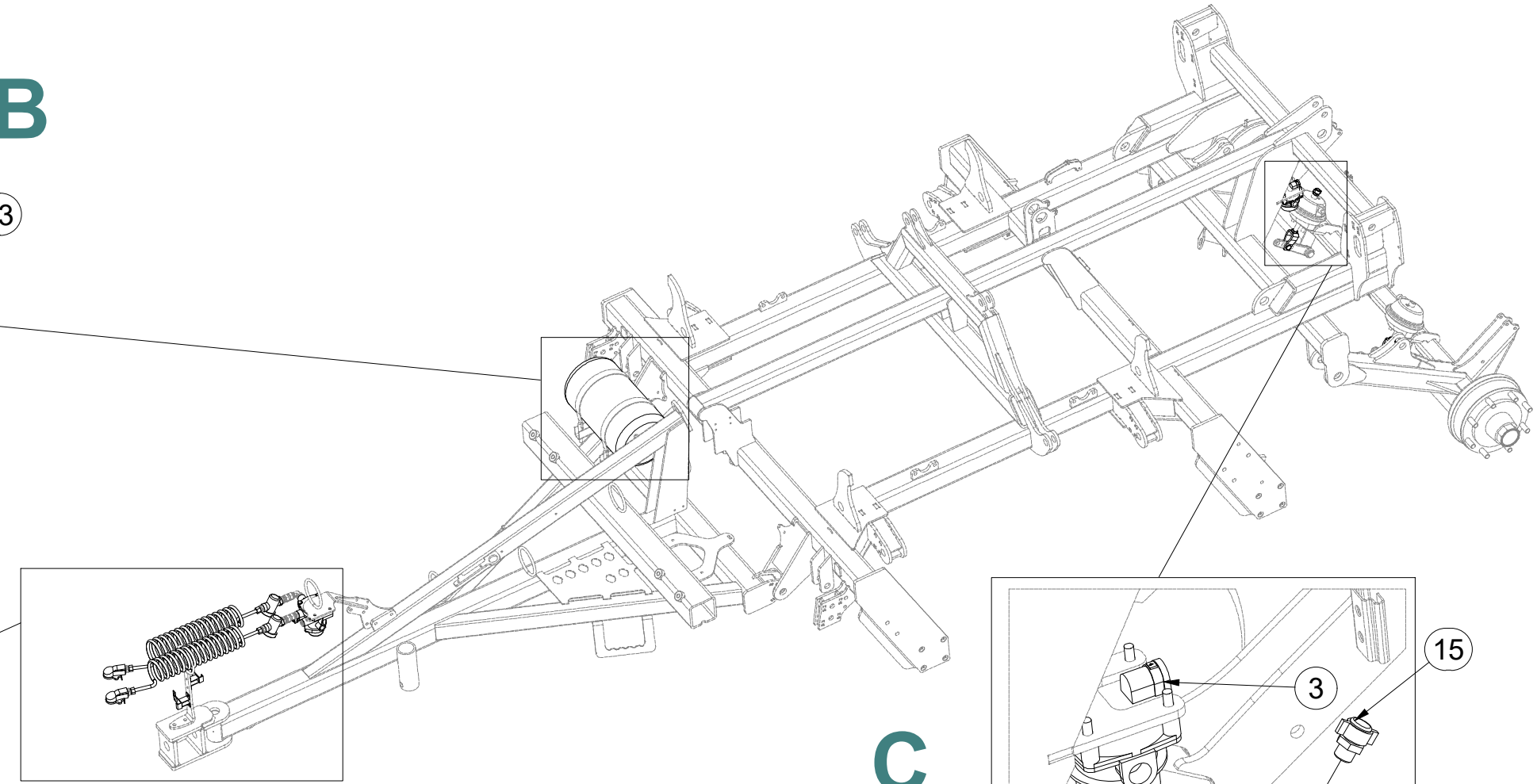

C

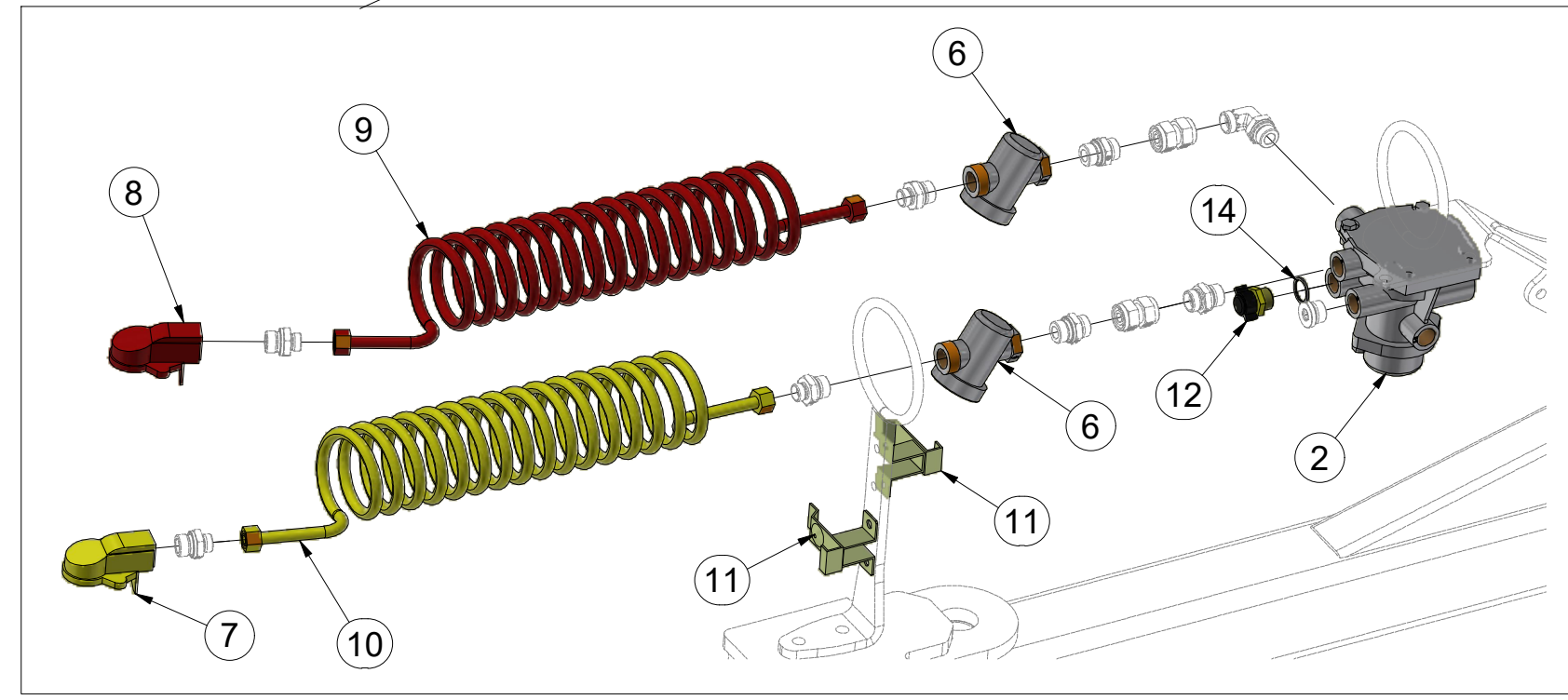

A

Pos.	Part Number	Pcs.	Pos.	Part Number	Pcs.
2	m10608	1	11	m09789	2
3	m09790	1	12	m09816	2
5	m09793	2	13	m09797	1
6	m11733	2	14	m09818	3
7	m11734	1	15	m09815	1
8	m11735	1	16	m09817	1
9	m09949	1	23	m18903	1
10	m09948	1			

Ⓒ SADA NÁPRAVY

Ⓓ SATZ AUFHÄNGUNG

Ⓕ KIT DE L'ESSIEU

Ⓒ AXLE SET

Ⓓ КОМПЛЕКТ ОСИ КОЛЁС

Ⓕ ZESTAW OSI



m19041

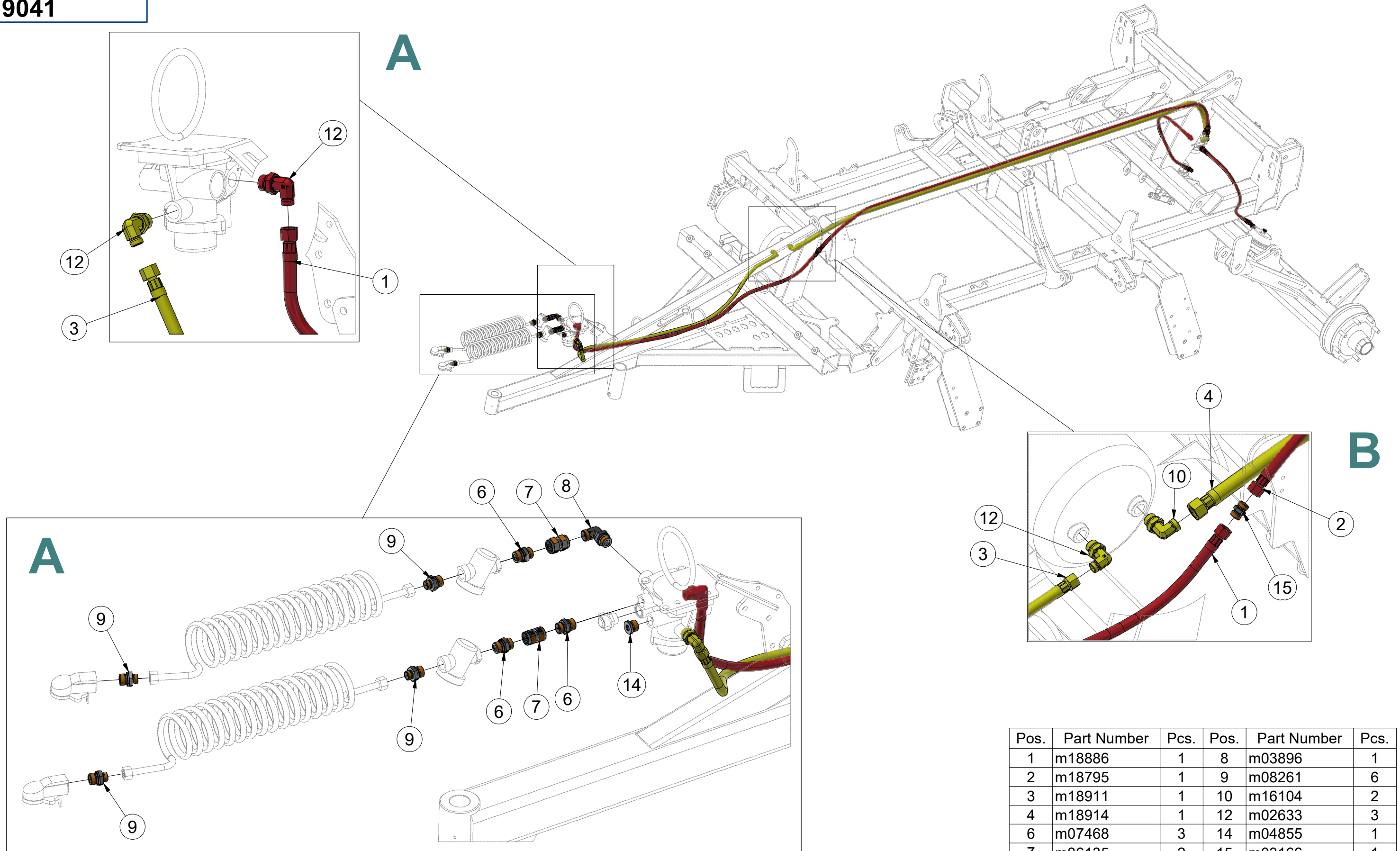

Pos.	Part Number	Pcs.	Pos.	Part Number	Pcs.
1	m18886	1	8	m03896	1
2	m18795	1	9	m08261	6
3	m18911	1	10	m16104	2
4	m18914	1	12	m02633	3
6	m07468	3	14	m04855	1
7	m06135	2	15	m03166	1

- Ⓒ SADA NÁPRAVY
- Ⓓ SATZ AUFHÄNGUNG
- Ⓕ KIT DE L'ESSIEU

- Ⓒ AXLE SET
- Ⓓ КОМПЛЕКТ ОСИ КОЛЁС
- Ⓕ ZESTAW OSI



m19041

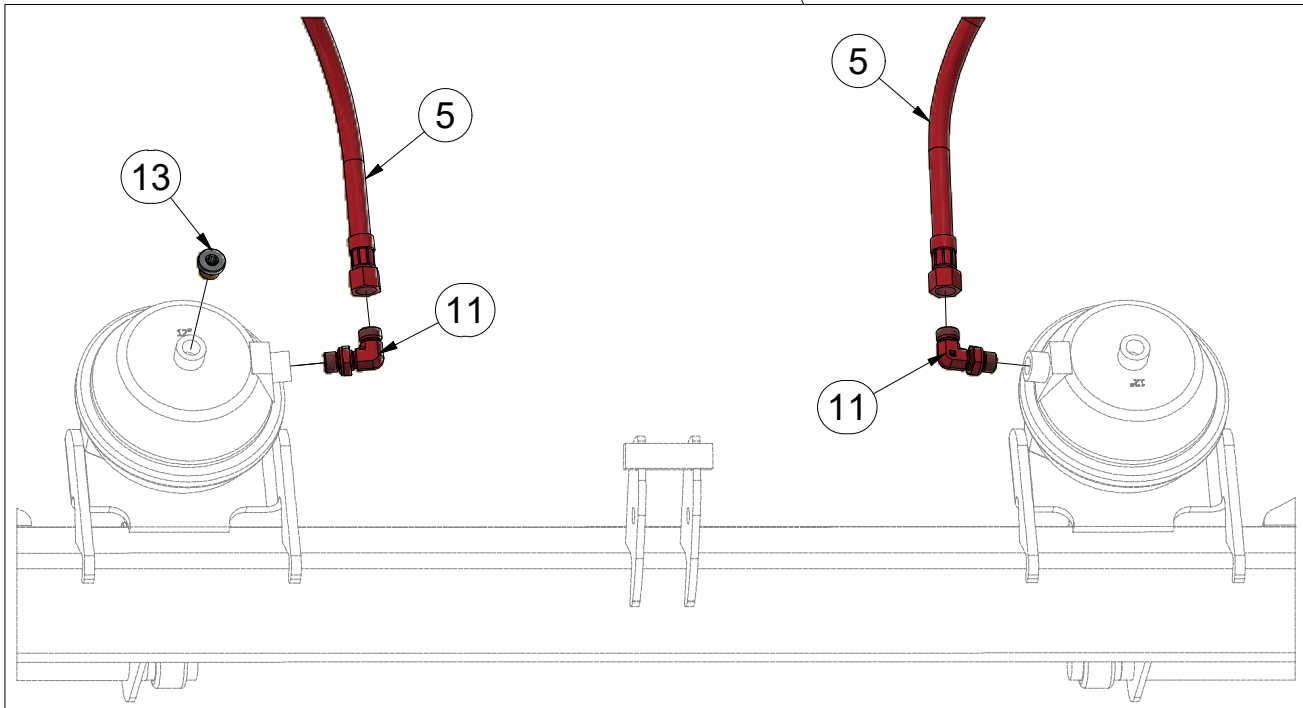
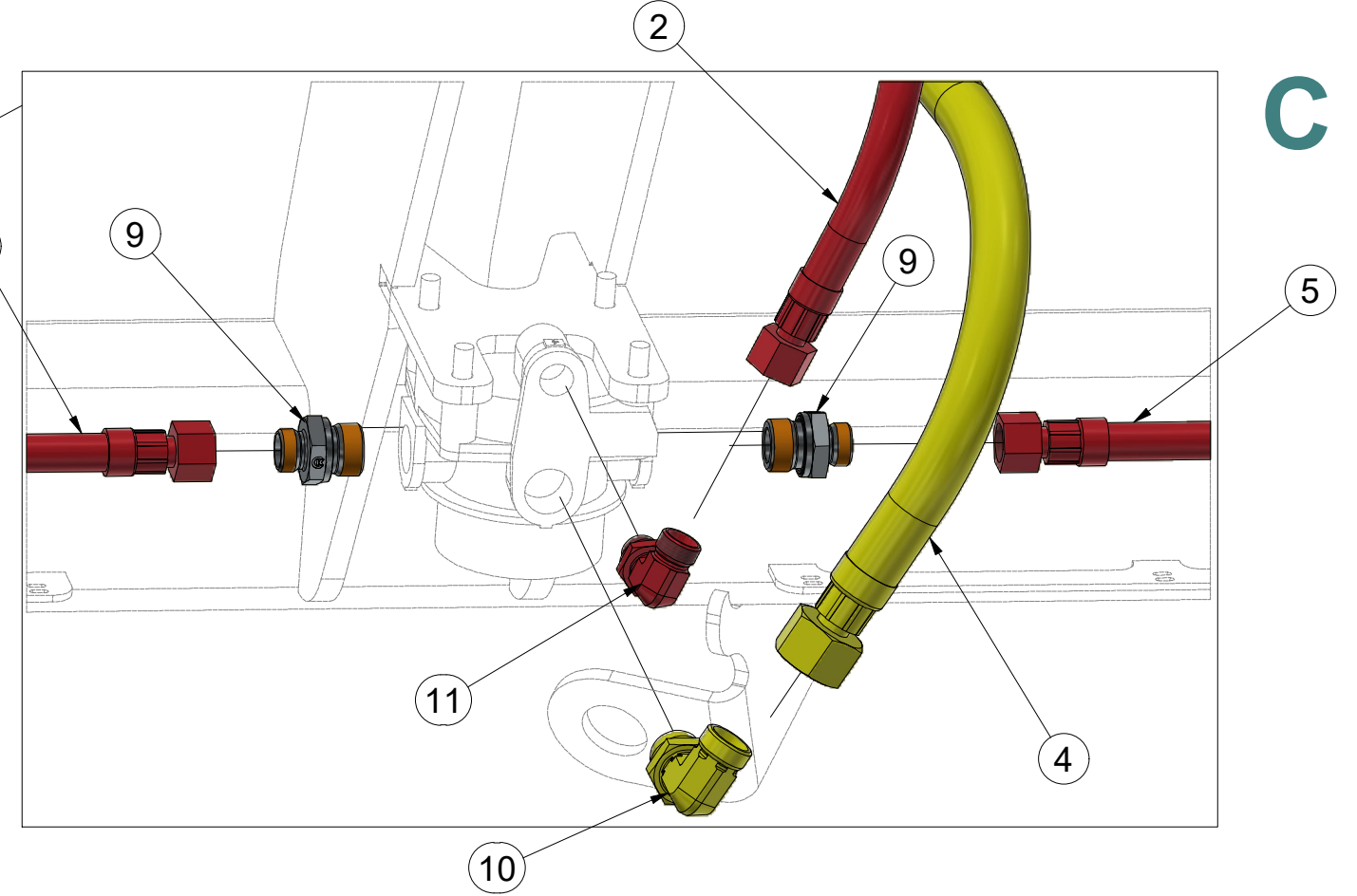
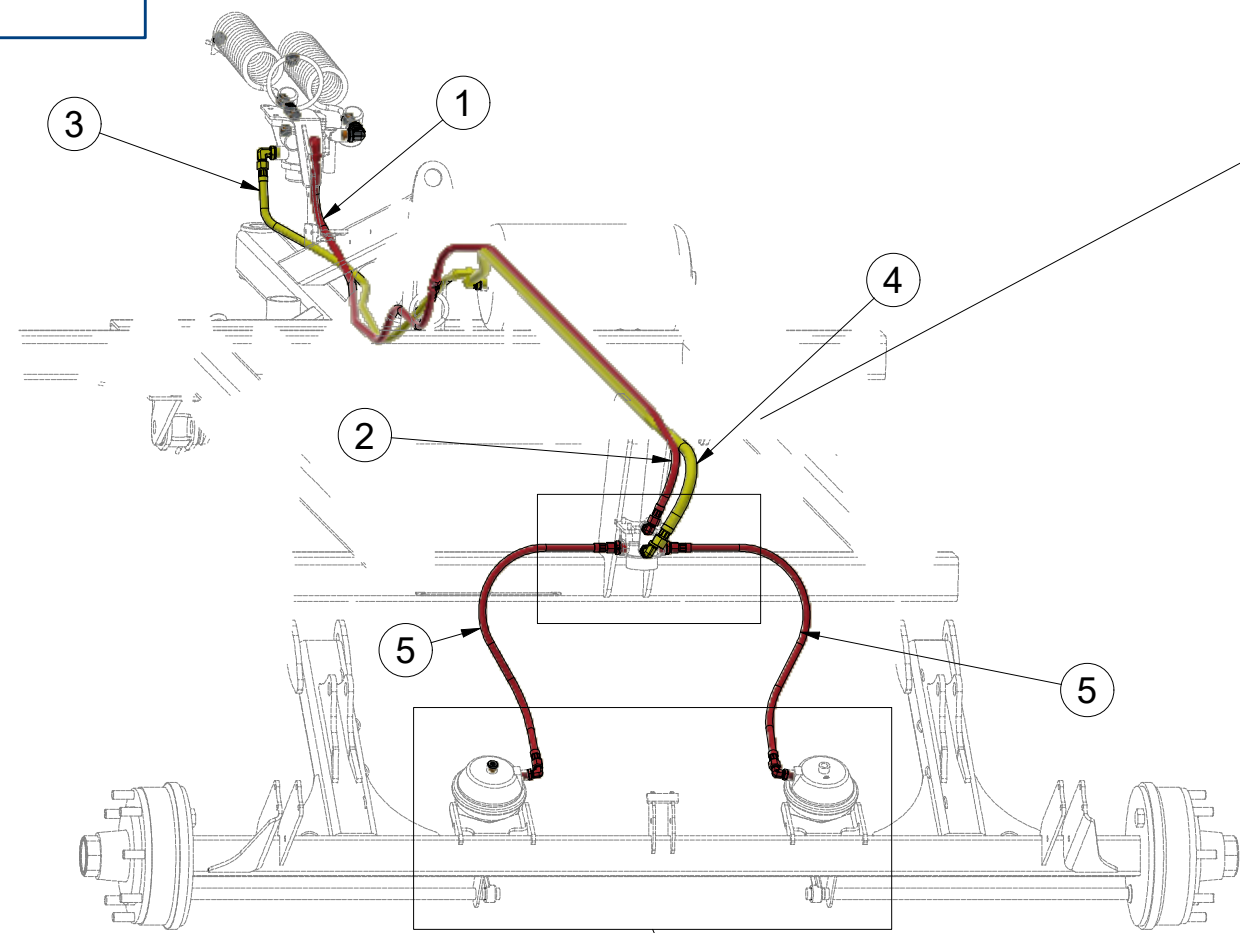

C

Pos.	Part Number	Pcs.
1	m18886	1
2	m18795	1
3	m18911	1
4	m18914	1
5	m18879	2
9	m08261	6
10	m16104	2
11	m17575	3
13	m04518	1

Ⓒ NÁPRAVA

Ⓓ ACHSE

Ⓕ ESSIEU

Ⓖ AXLE

Ⓡ OCB

Ⓟ OS



A70NA8FFN003

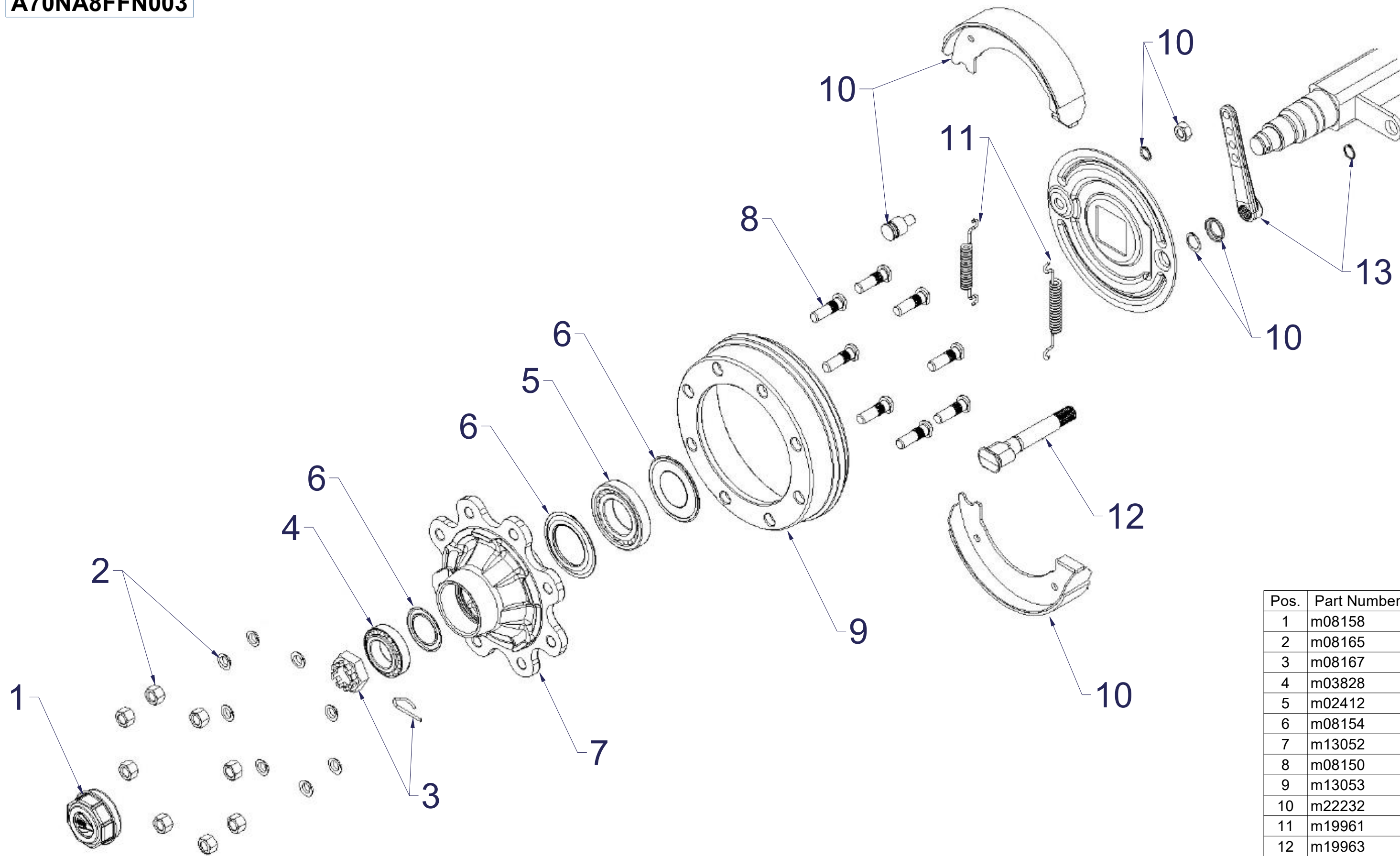

Pos.	Part Number	Pcs.
1	m08158	2
2	m08165	16
3	m08167	2
4	m03828	2
5	m02412	2
6	m08154	2
7	m13052	2
8	m08150	16
9	m13053	2
10	m22232	2
11	m19961	2
12	m19963	2
13	m19966	2

Ⓒ CZ SADA NÁPRAVY

Ⓓ D SATZ AUFHÄNGUNG

Ⓕ F KIT DE L'ESSIEU

Ⓖ GB AXLE SET

Ⓡ RU КОМПЛЕКТ ОСИ КОЛЁС

Ⓟ PL ZESTAW OSI



4026182

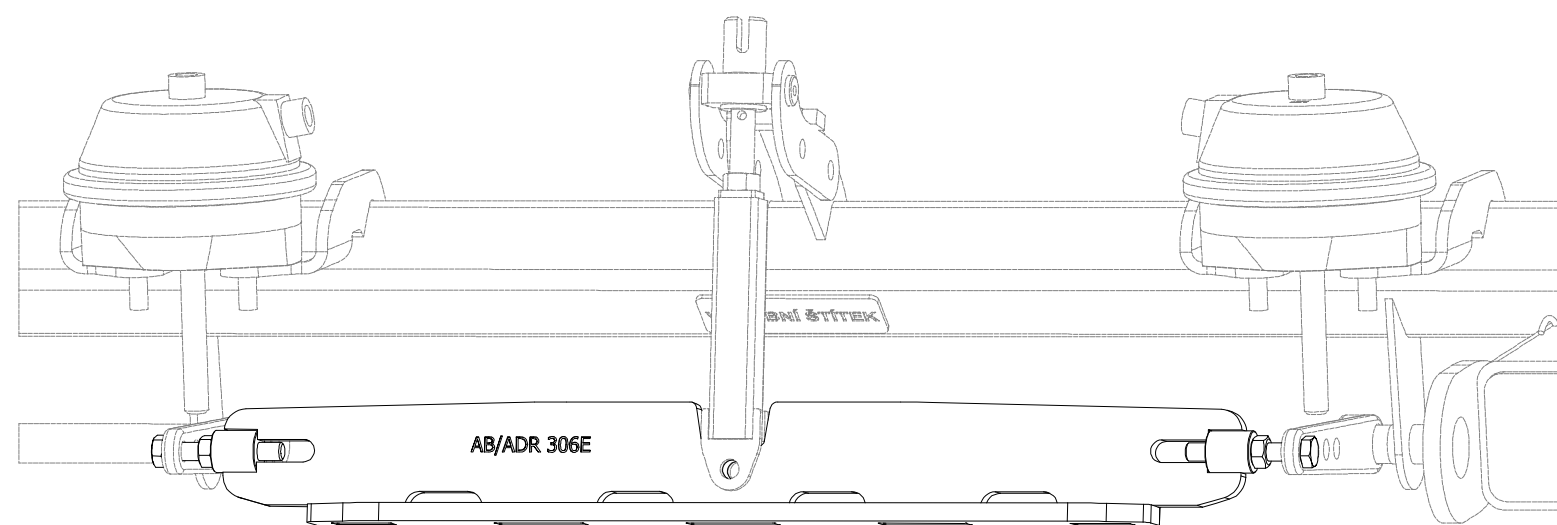

Pos.	Part Number	Pcs.
1	3012890	1
5	m06446	2
10	m01305	2

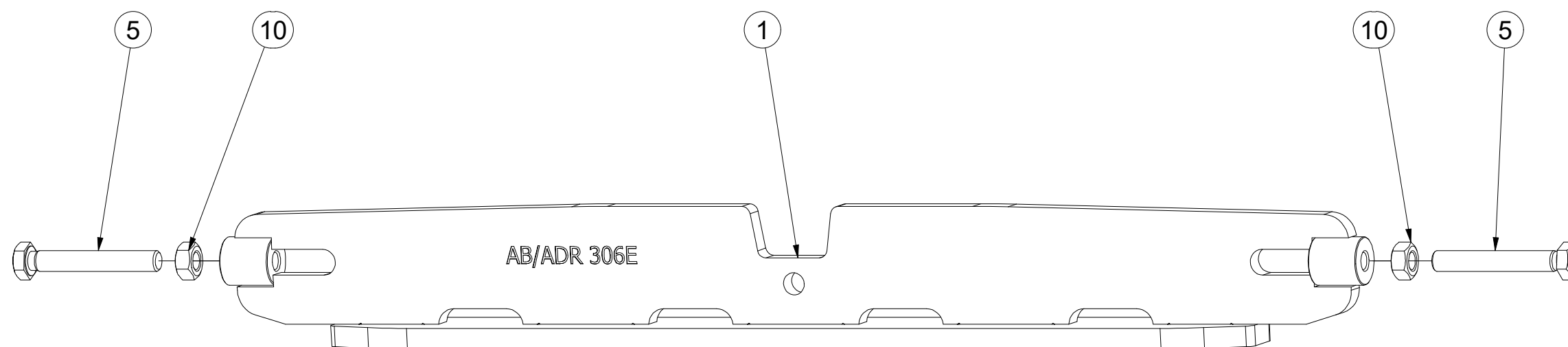

(CZ) SADA HOMOLOGACE
 (D) HOMOLOGATIONSATZ
 (F) KIT DE HOMOLOGATION

(GB) SET OF HOMOLOGATION
 (RU) КОМПЛЕКТ УТВЕРЖДЕНИЯ
 (PL) ZESTAW HOMOLOGACJA



VZ00018454

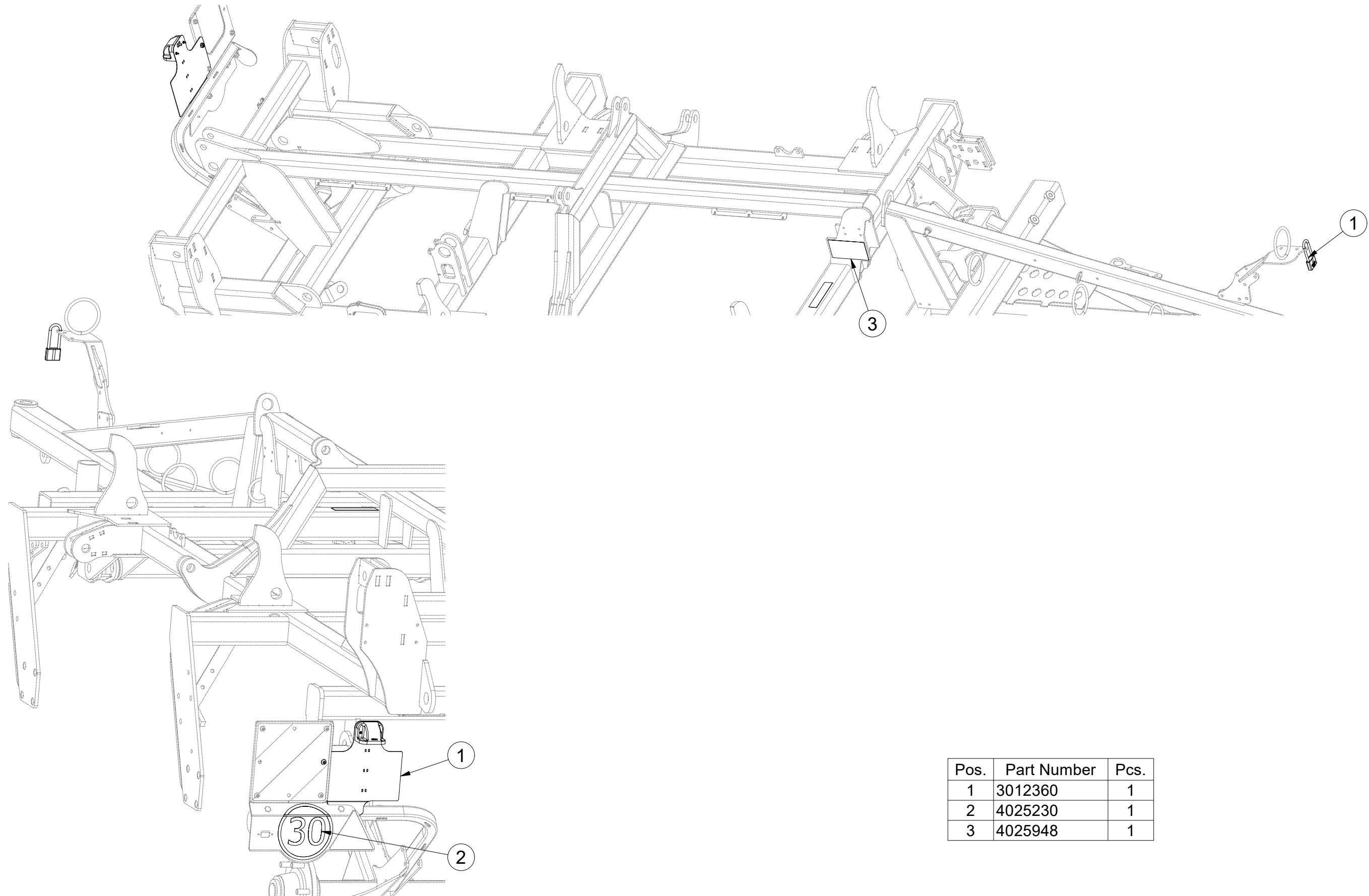

Pos.	Part Number	Pcs.
1	3012360	1
2	4025230	1
3	4025948	1

ⒸZ TERČ ZADNÍ LEVÝ - HOMOLOGACE

Ⓓ SCHILD, HINTERES, LINKES - HOMOLOGATION

Ⓕ CIBLE ARRIÈRE GAUCHE - HOMOLOGATION

ⒸB LEFT REAR DISC - HOMOLOGATION

⒲U ЩИТОК ЗАДНИЙ ЛЕВЫЙ - УТВЕРЖДЕНИЯ

⒲L TARCZA TYLNA LEWA - HOMOLOGACJA

Farmet

3012360

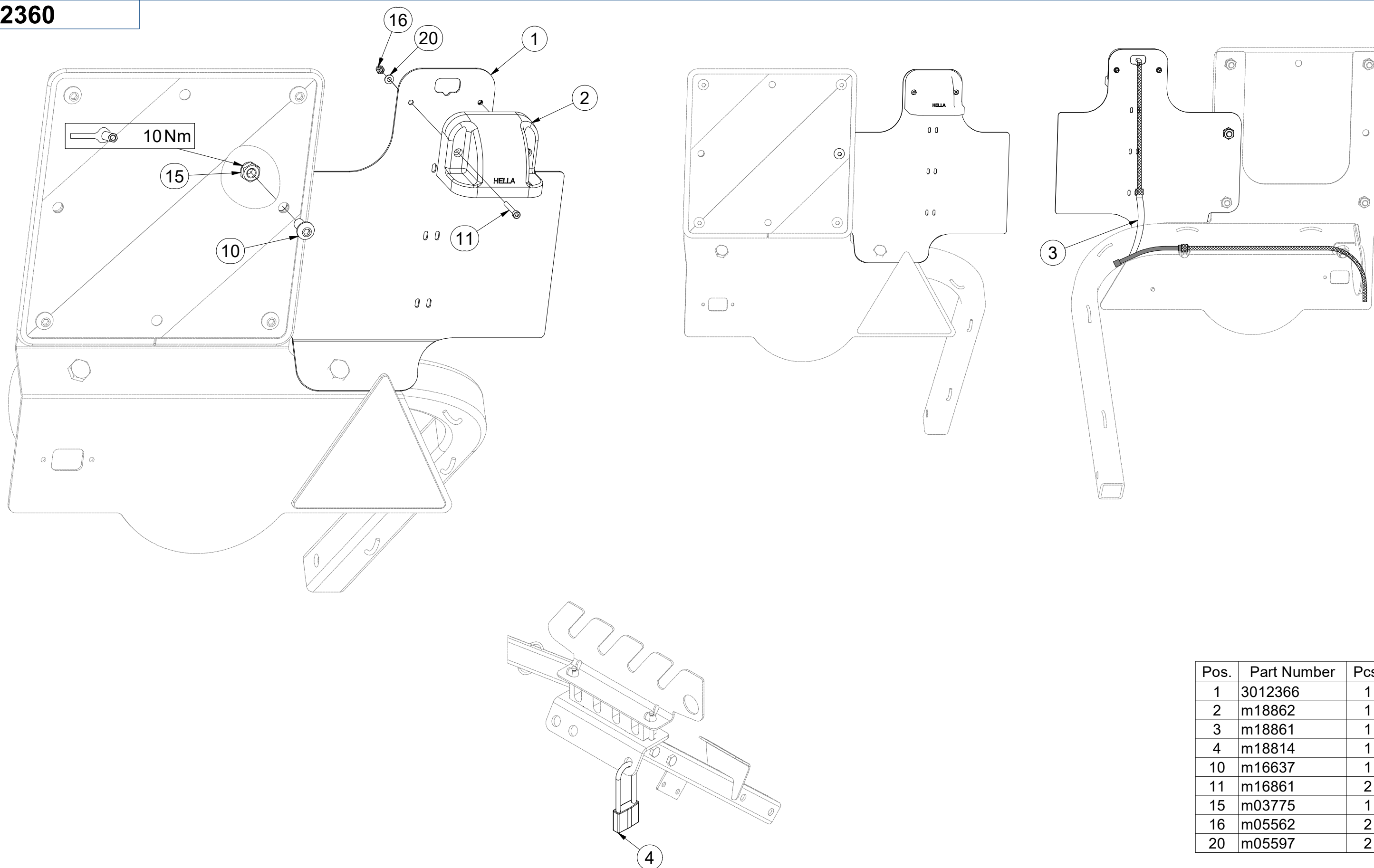

Pos.	Part Number	Pcs.
1	3012366	1
2	m18862	1
3	m18861	1
4	m18814	1
10	m16637	1
11	m16861	2
15	m03775	1
16	m05562	2
20	m05597	2

ⒸZ TERČ ZADNÍ LEVÝ

Ⓓ SCHILD, HINTERES, LINKES

Ⓕ CIBLE ARRIÈRE GAUCHE

3012431

ⒼB LEFT REAR DISC

ⒺЩИТОК ЗАДНИЙ ЛЕВЫЙ

ⒽL TARCZA TYLNA LEWA

Farmet

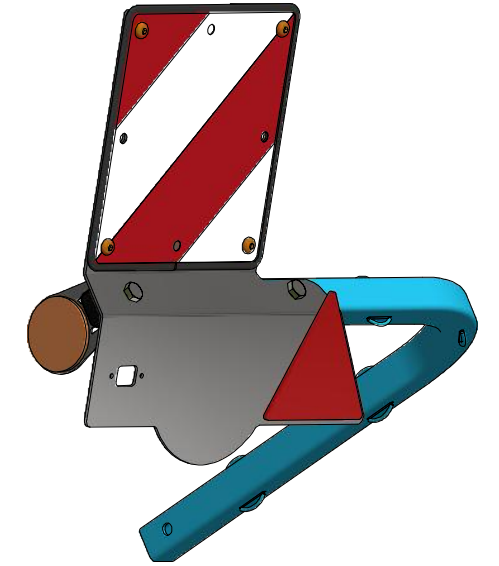
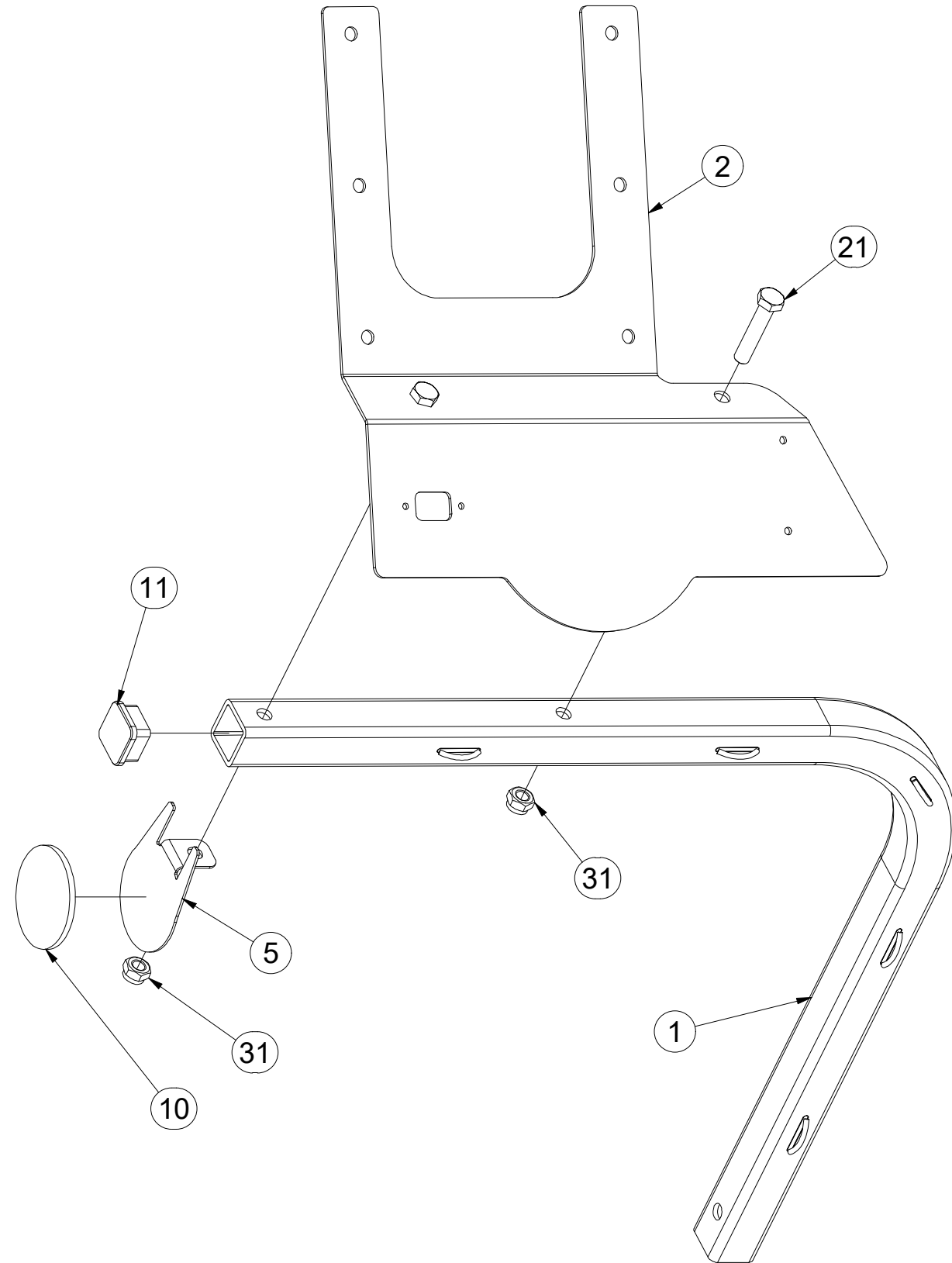

Pos.	Part Number	Pcs.
1	3012433	1
2	3012365	1
5	4024926	1
10	m02579	1
11	m12689	1
21	m01131	2
31	m04301	2

ⒸZ TERČ ZADNÍ LEVÝ

Ⓓ SCHILD, HINTERES, LINKES

Ⓕ CIBLE ARRIÈRE GAUCHE

ⒼB LEFT REAR DISC

ⒶU ЩИТОК ЗАДНИЙ ЛЕВЫЙ

ⒶL TARCZA TYLNA LEWA



3012431

Pos.	Part Number	Pcs.
3	m18855	1
4	9005707	1
12	m02497	1
20	m16637	4
30	m03775	4
35	m01209	4

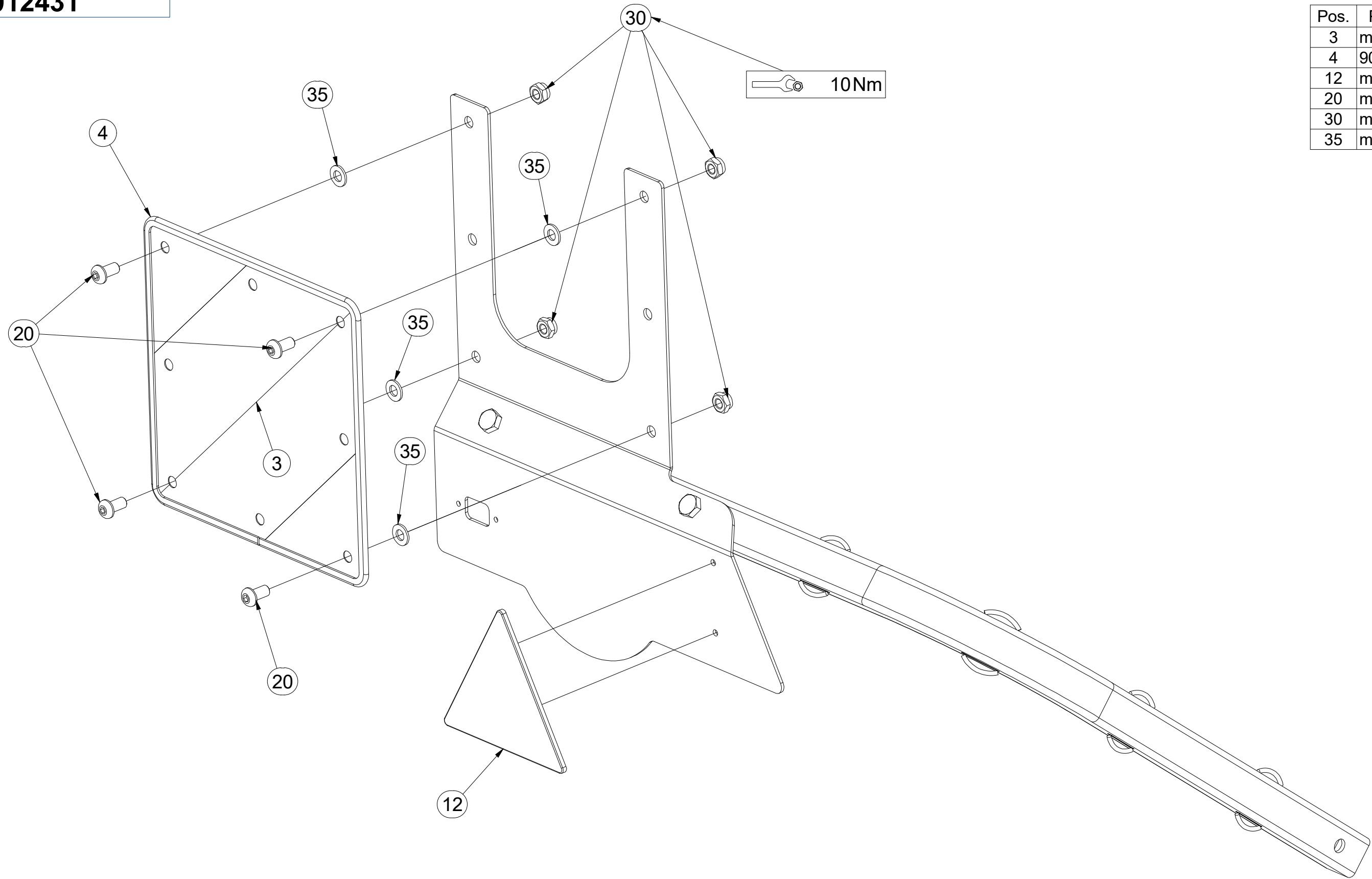

ⒸZ TERČ ZADNÍ PRAVÝ

Ⓓ SCHILD, HINTERES, RECHTES

Ⓕ CIBLE ARRIÈRE DROITE

3012432

ⒼB RIGHT REAR DISC

ⒺЩИТОК ЗАДНИЙ ПРАВЫЙ

ⒽL TARCZA TYLNA PRAWA

Farmet

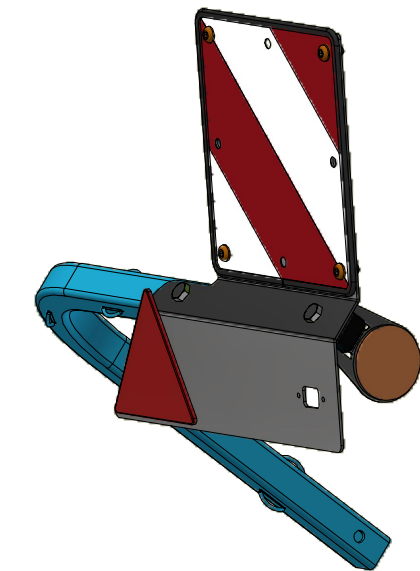
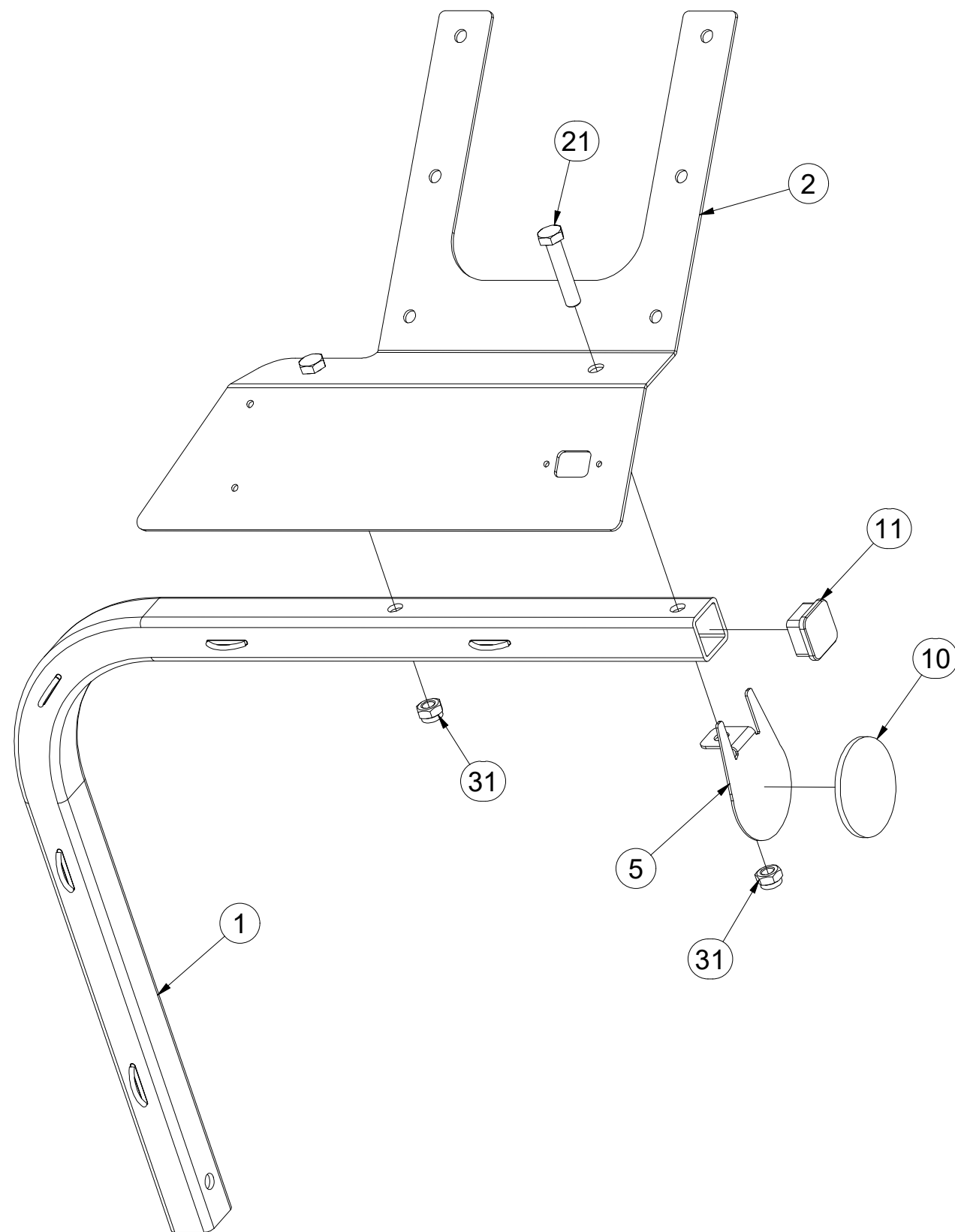

Pos.	Part Number	Pcs.
1	3012433	1
2	3012390	1
5	4024926	1
10	m02579	1
11	m12689	1
21	m01131	2
31	m04301	2

ⒸZ TERČ ZADNÍ PRAVÝ

Ⓓ SCHILD, HINTERES, RECHTES

Ⓕ CIBLE ARRIÈRE DROITE

ⒼB RIGHT REAR DISC

ⒺЩИТОК ЗАДНИЙ ПРАВЫЙ

ⒽL TARCZA TYLNA PRAWA

Farmet

3012432

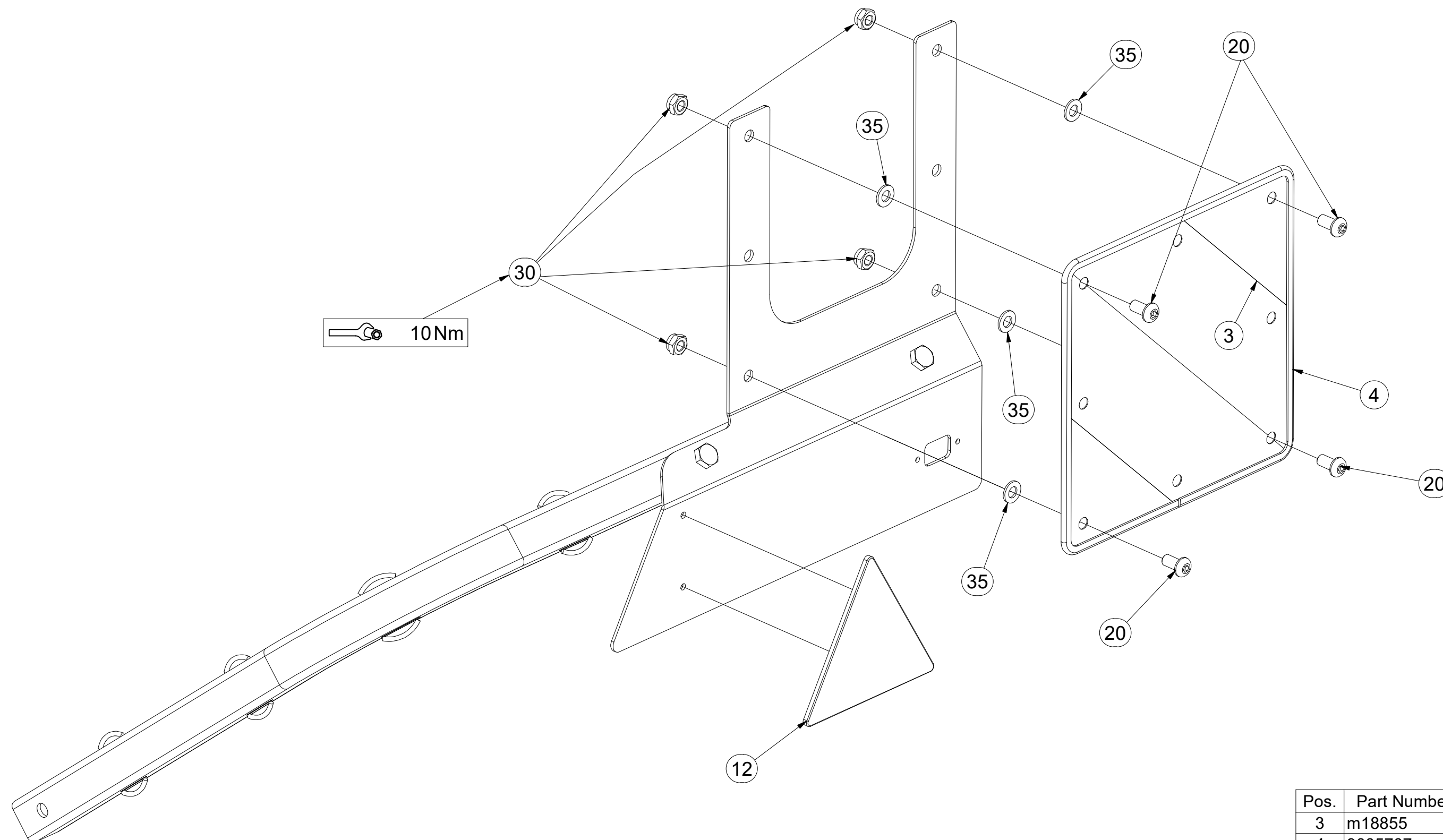

Pos.	Part Number	Pcs.
3	m18855	1
4	9005707	1
12	m02497	1
20	m16637	4
30	m03775	4
35	m01209	4

4025230

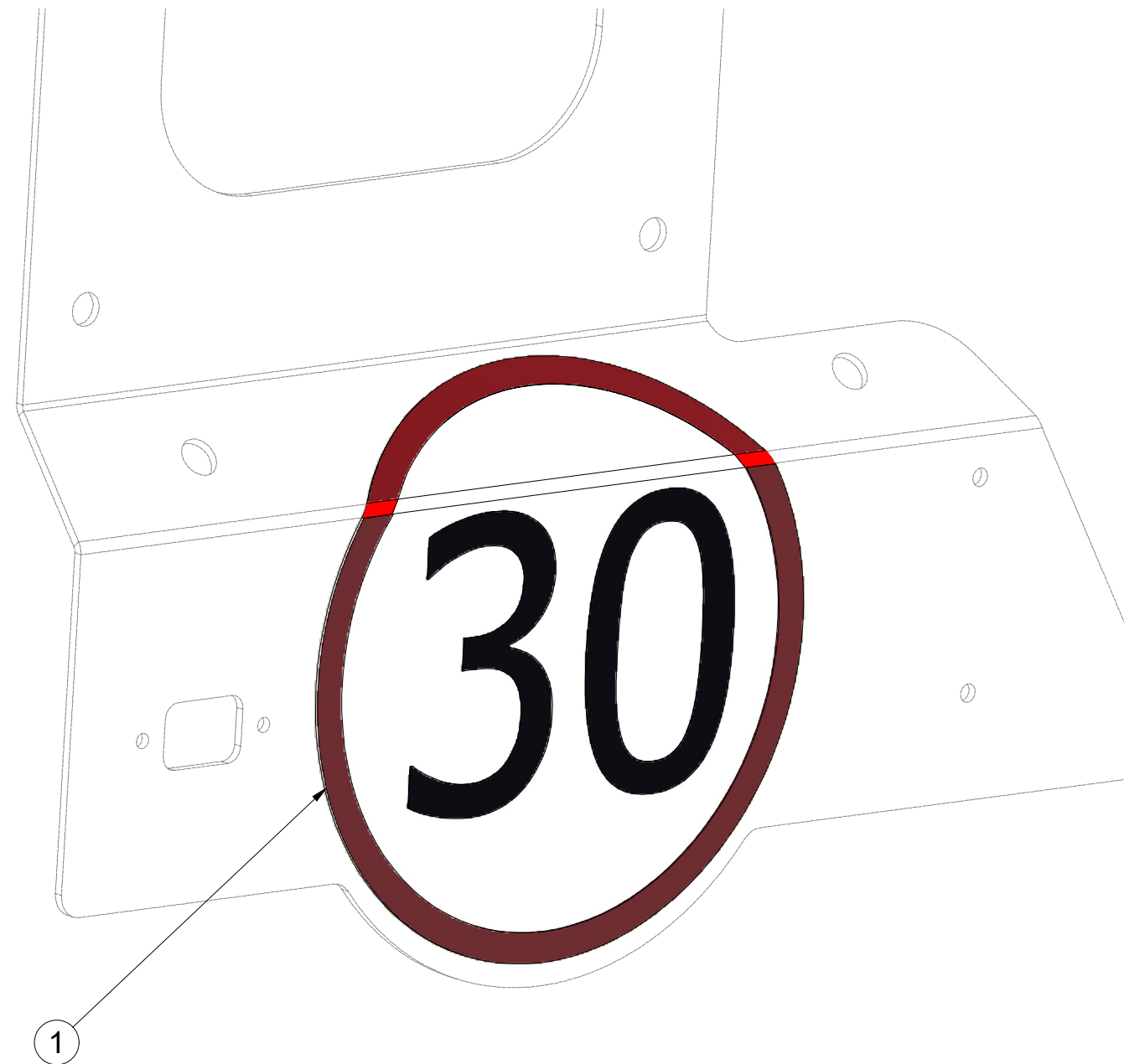

Pos.	Part Number	Pcs.
1	m19161	1

Ⓒ SVĚTELNÁ SADA

Ⓓ LEUCHTENSATZ

Ⓕ KIT LUMINEUX

Ⓖ LIGHTING SET

Ⓡ ОСВЕТИТЕЛЬНЫЙ КОМПЛЕКТ

Ⓟ ZESTAW OŚWIETLENIA



3012429

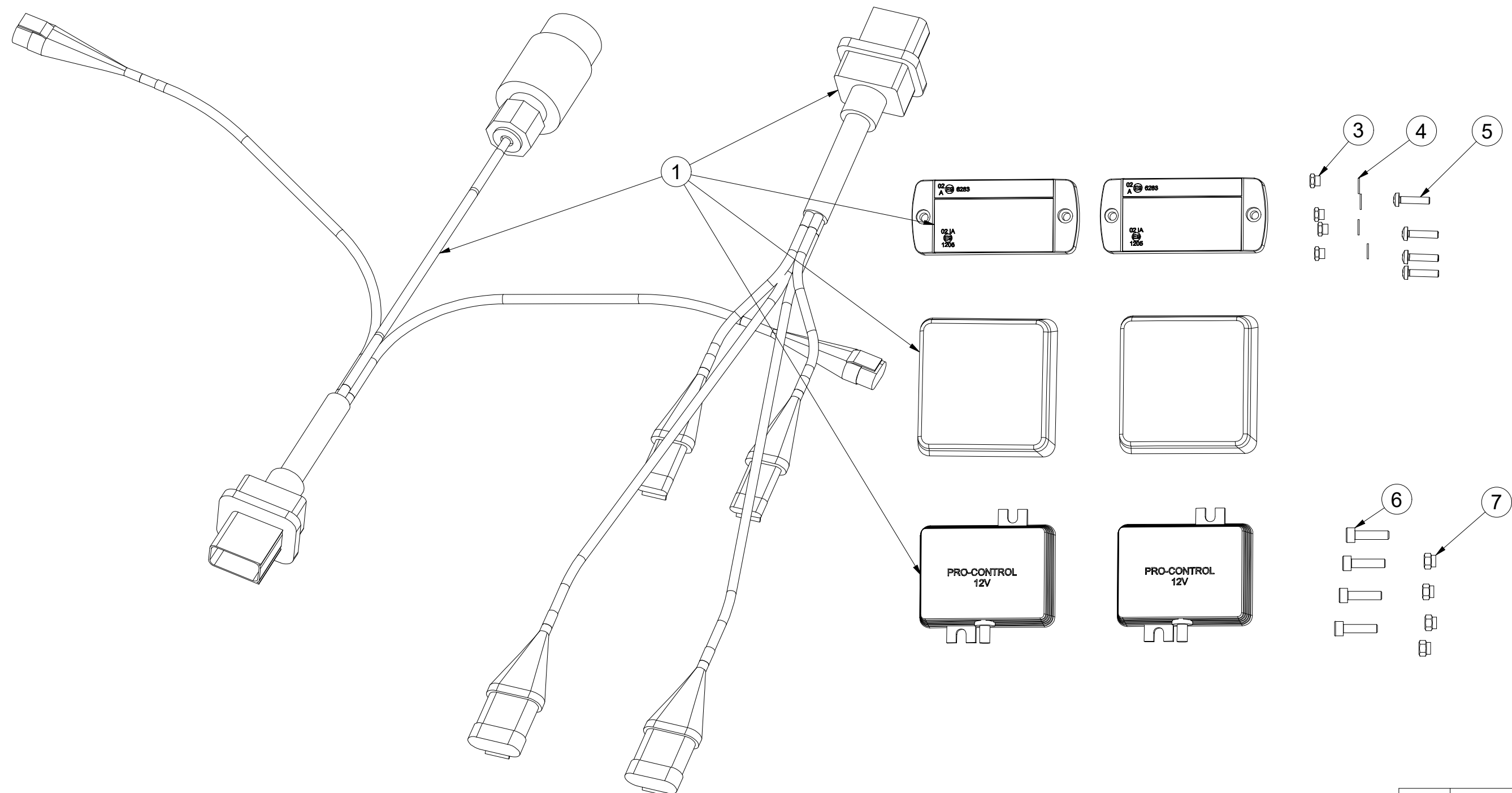

Pos.	Part Number	Pcs.
1	m19043	1
3	m05562	4
4	m05597	4
5	m15790	4
6	m10591	4
7	m06236	4

Ⓒ SVĚTELNÁ SADA

Ⓓ LEUCHTENSATZ

Ⓕ KIT LUMINEUX

Ⓒ LIGHTING SET

Ⓓ ОСВЕТИТЕЛЬНЫЙ КОМПЛЕКТ

Ⓕ ZESTAW OŚWIETLENIA



3012429

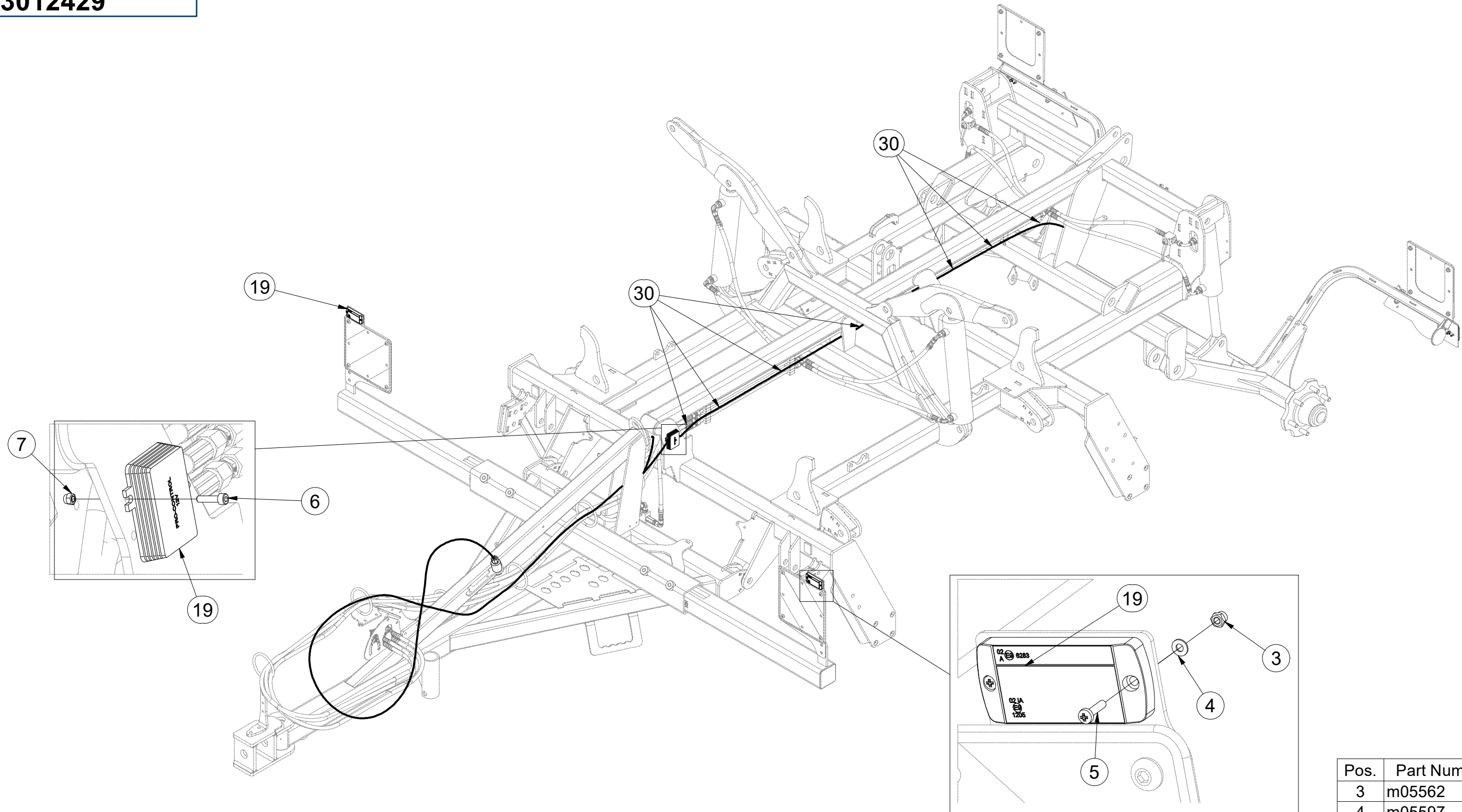

Pos.	Part Number	Pcs.
3	m05562	4
4	m05597	4
5	m15790	4
6	m10591	4
7	m06236	4
19	m19043	1
30	m05566	50

Ⓒ SVĚTELNÁ SADA

Ⓓ LEUCHTENSATZ

Ⓕ KIT LUMINEUX

Ⓖ LIGHTING SET

Ⓔ ОСВЕТИТЕЛЬНЫЙ КОМПЛЕКТ

Ⓗ ZESTAW OŚWIETLENIA

Farmet

3012429

Pos.	Part Number	Pcs.
19	m19043	1
30	m05566	50

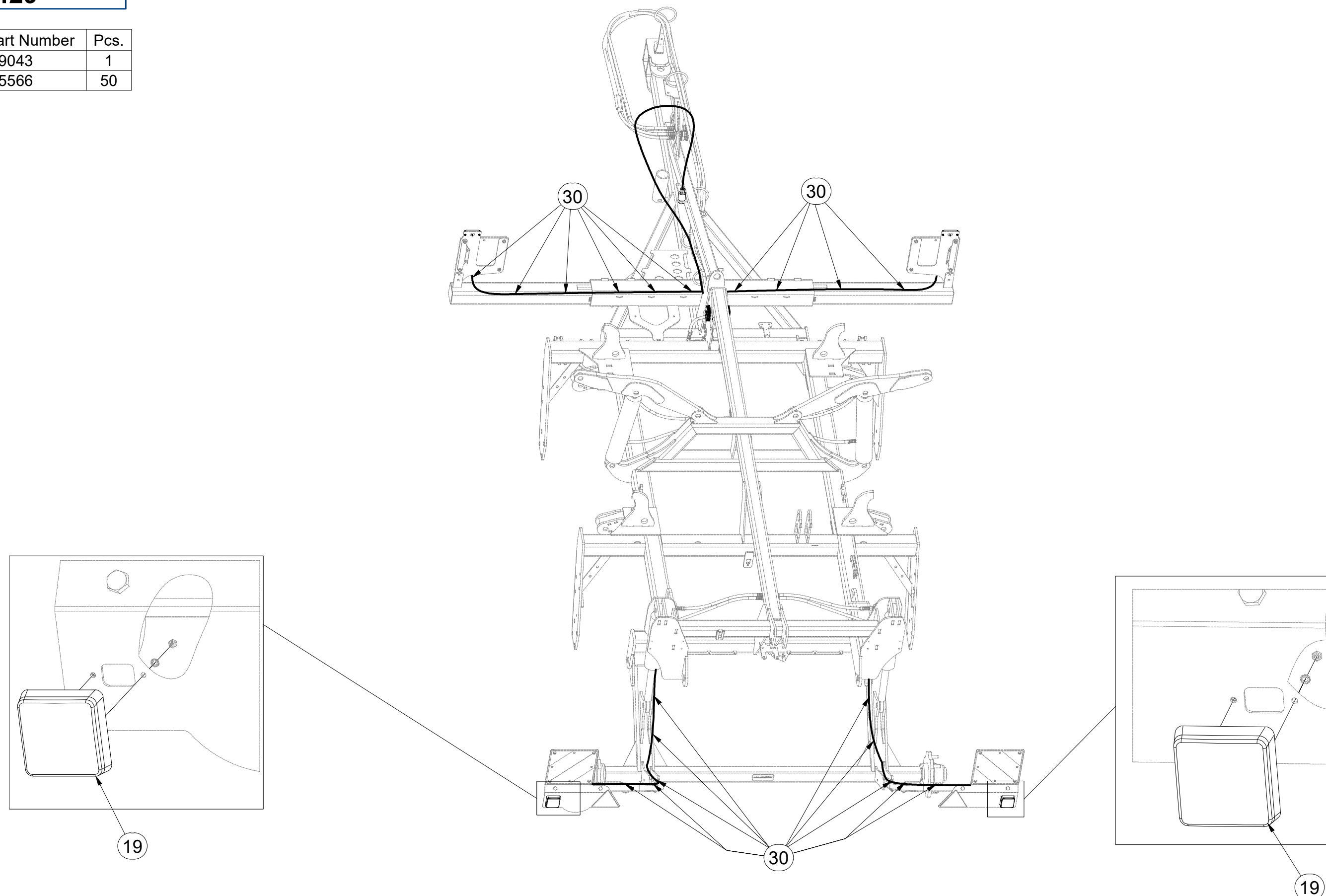

Ⓒ SVĚTELNÁ SADA

Ⓓ LEUCHTENSATZ

Ⓕ KIT LUMINEUX

Ⓖ LIGHTING SET

Ⓡ ОСВЕТИТЕЛЬНЫЙ КОМПЛЕКТ

Ⓢ ZESTAW OŚWIETLENIA



m19043

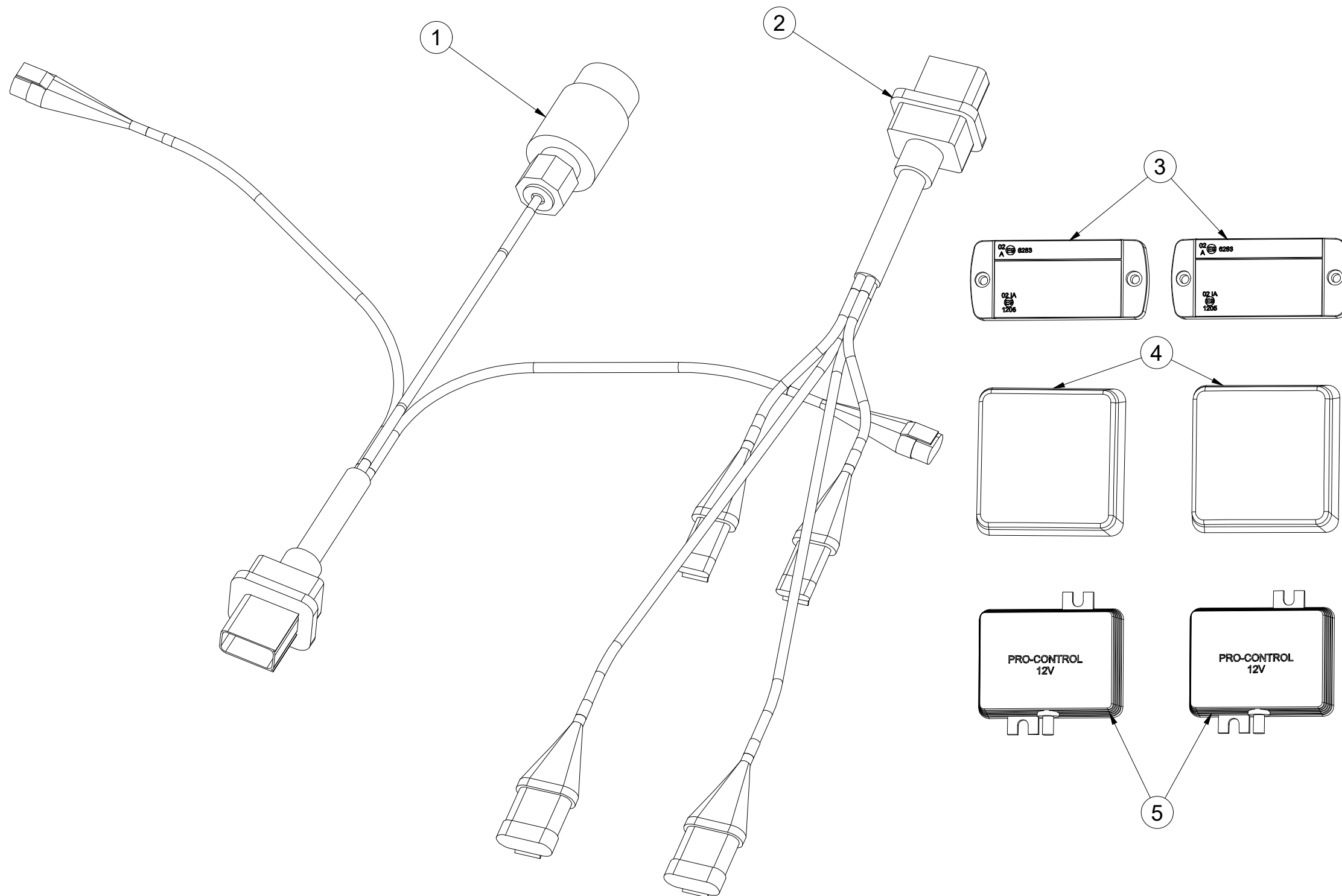

Pos.	Part Number	Pcs.
1	m14779	1
2	m14778	1
3	m14776	2
4	m19044	2
5	m14777	2

ⒸZ SOUPRAVA TĚSNIVA PÍSTNIC

Ⓓ KOLBENSTANGENDICHTUNGSMITTELSATZ

Ⓕ SET DE GARNITURE DES TIGES DE PISTON

ⒼB SEALING SET FOR PISTON RODS

ⒺRU КОМПЛЕКТ ПРОКЛАДОК ЦИЛИНДРОВ

ⒼL ZESTAW USZCZELEK TRZPIENIA TŁOKA

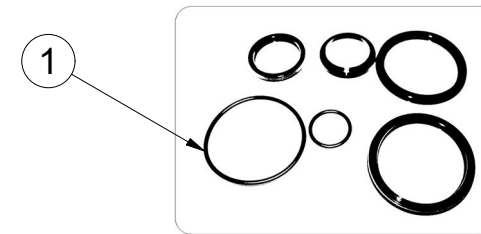
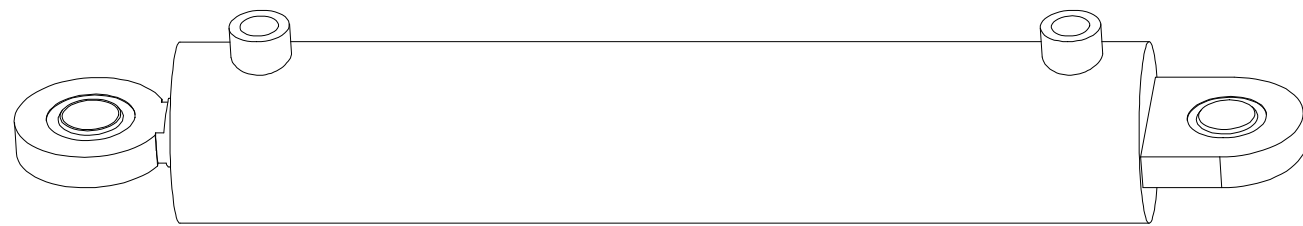

VZ00004544 - $\varnothing 80/\varnothing 40-400$		
Pos	Part number	Pcs
1	m20702	2

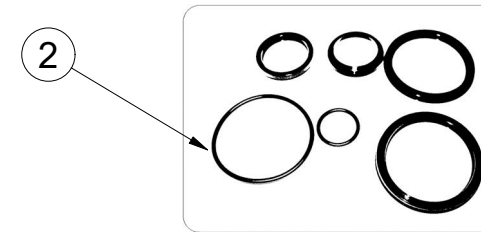
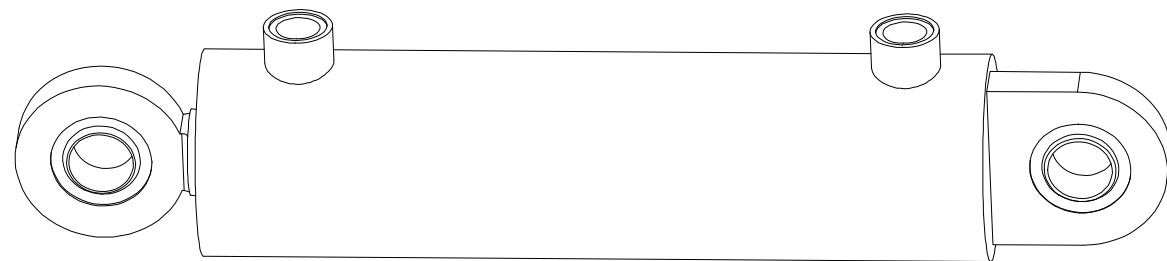

VZ0004549 - $\varnothing 80/\varnothing 40-250$		
Pos	Part number	Pcs
2	m20702	2

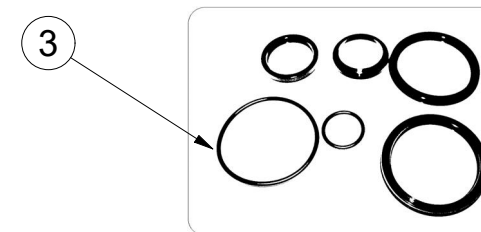
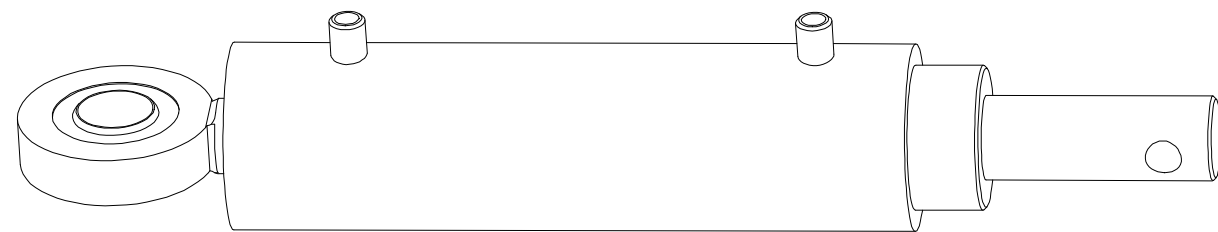

VZ00012972 - $\varnothing 50/\varnothing 25-125$		
Pos	Part number	Pcs
3	m21161	3

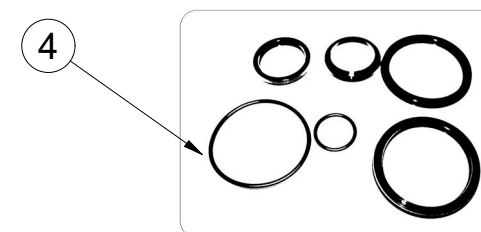
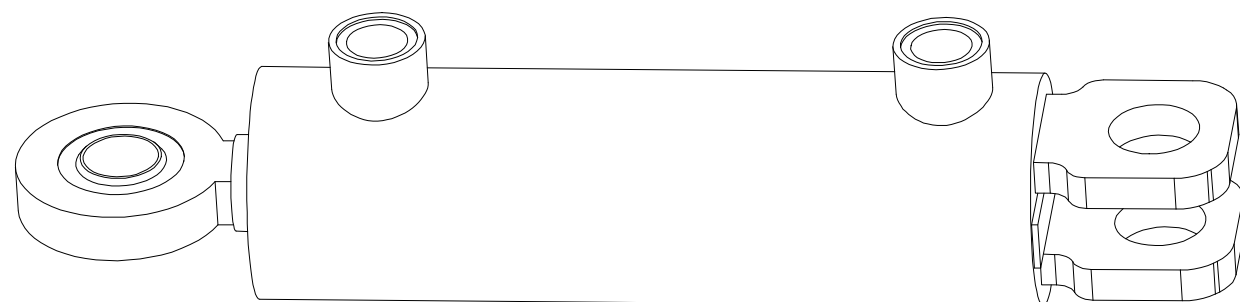

VZ00014414 - $\varnothing 63/\varnothing 32-160$		
Pos	Part number	Pcs
4	m22613	2

- Ⓒ UTAHOVACÍ MOMENTY ŠROUBŮ
 Ⓓ ANZUGMOMENTE VON SCHRAUBEN
 Ⓕ COUPLES DE SERRAGE DES VIS

- Ⓒ SCREW TIGHTENING TORQUE
 Ⓓ МОМЕНТЫ ЗАЖАТИЯ БОЛТОВ
 Ⓕ MOMENTY DOKRĘCANIA ŚRUB



P		5.8	8.8	10.9	12.9	Z	
D	R	Mu	Mu	Mu	Mu	DIN 7991	ISO 10642
mm	mm	Nm	Nm	Nm	Nm	Nm	Nm
M6	1	6	9	13	15	7,2	7,9
M8	1,25	14	22	32	38	17	19
M10	1,5	29	44	64	75	35	38
M12	1,75	49	76	111	130	58	65
M14	2	79	120	176	206	93	100
M16	2	123	188	276	323	144	158
M18	2,5	169	257	378	443	-	220
M20	2,5	239	365	536	628	-	310
M22	2,5	329	529	738	864	-	420
M24	3	413	629	924	1082	-	530
M27	3	613	934	1372	1606	-	-
M30	3,5	832	1267	1862	2179	-	-
M33	3,5	1130	1723	2530	2961	-	-
M36	4	1451	2210	3246	3799	-	-
M39	4	1885	2872	4217	4936	-	-
M42	4,5	2322	3538	5196	6080	-	-
M45	4,5	2909	4433	6511	7619	-	-
M48	5	3513	535	7862	9200	-	-
M52	5	4524	6895	10123	11849	-	-
M56	5,5	5636	8589	12614	14761	-	-

- Mu - Ⓒ UTAHOVACÍ MOMENT
 Ⓓ ANZUGMOMENTE
 Ⓕ COUPLE DE SERRAGE
 Ⓒ TIGHTENING TORQUE
 Ⓓ МОМЕНТ ЗАЖАТИЯ
 Ⓕ MOMENT DOKRĘCANIA
- D - Ⓒ JMENOVITÝ PRŮMĚR
 Ⓓ NENNDURCHMESSER
 Ⓕ DIAMETRE NOMINAL
 Ⓒ NOMINAL DIAMETER
 Ⓓ НОМИНАЛЬНЫЙ ДИАМЕТР
 Ⓕ ŚREDNICA NOMINALNA
- R - Ⓒ ROZTEČ ZÁVITU - STOUPÁNÍ
 Ⓓ GEWINDESTEIGUNG
 Ⓕ PAS DE FILET - PAS
 Ⓒ SCREW PITCH – LEAD
 Ⓓ ШАГ РЕЗЬБЫ
 Ⓕ ROZSTAW GWINTU - SKOKI
- P - Ⓒ PEVNOST
 Ⓓ FESTIGKEIT
 Ⓕ RÉSISTANCE
 Ⓒ STRENGTH
 Ⓓ ПРОЧНОСТЬ
 Ⓕ WYTRZYMA OŚĆ
- Z - Ⓒ ZÁPUSTNÉ ŠROUBY
 Ⓓ SENKKOPFSCHRAUBEN
 Ⓕ VIS A TETE FRAISEE
 Ⓒ COUNTERSUNK SCREWS
 Ⓓ БОЛТЫ С УТОПЛЕННОЙ ГОЛОВКОЙ
 Ⓕ ŚRUBY Z ŁBEM STOŻKOWYM PŁASKIM

- Ⓒ Hodnoty momentů jsou poníženy o -10% oproti tabulkovým hodnotám. Šroubové spoje utahujte dle vyznačeného utahovacího momentu v dokumentaci. Pokud není utahovací moment v dokumentaci vyznačen, utahujte dle obecné tabulky. Pokud je v dokumentaci definován spoj šroubu a matice o různých pevnostech, vždy utahujte na moment komponenty nižší.
- Ⓓ Die Werte der Anzugsmomente sind um 10 % gegenüber den Tabellenwerten verringert. Ziehen Sie die Schraubverbindungen gemäß dem in der Dokumentation festgeschrieben Anzugsmoment an. Sofern das Anzugsmoment nicht in der Dokumentation aufgeführt ist, ziehen Sie sie gemäß der allgemeinen Tabelle an. Wenn in der Dokumentation eine Verbindung von Schraube und Mutter mit verschiedene Festigkeiten definiert ist, wird immer mit dem Moment des Bauteils mit der geringeren Festigkeit angezogen.
- Ⓕ Les valeurs des couples de serrage sont baissées de 10% par rapport aux valeurs de tableau. Serrez les raccords à vis selon le couple de serrage indiqué dans les documents. Si le couple de serrage n'est pas indiqué dans les documents, serrez selon le tableau général. Si les documents définissent un assemblage par boulon de diverses résistances, serrez toujours au moment de la composante avec résistance inférieure.
- Ⓒ The torque values are reduced by 10% compared to the table values. Tighten the screw joints according to the tightening torque stated in the documentation. If the tightening torque is not stated in the documentation, tighten according to the general table. If there is a joint with a screw and a nut at different strengths in the documentation, always tighten to the torque of the component with lower strength.
- Ⓓ Значения моментов затяжки уменьшены на 10% по сравнению с данными в таблице. Резьбовые соединения зажимайте с установленным в документации моментом зажатия. Если в документации не указан момент зажатия, то зажимайте по действующей в общем таблице. Если в документации установлено соединение из болта и гайки различной прочности, всегда зажимайте с моментом для компонента с меньшей прочностью.
- Ⓕ Wartości momentów dokręcania są obniżone o 10% w stosunku do wartości z tabeli. Połączenia śrubowe należy dokręcać zgodnie z momentem obrotowym w dokumentacji. Jeśli w dokumentacji nie ma podanego momentu obrotowego, należy dokręcać zgodnie z ogólną tabelą. Jeśli w dokumentacji zdefiniowane jest połączenie ze śrubą nakrętką różnych wytrzymałościach, zawsze należy dokręcać zachowując moment dokręcania komponentu z niższą wytrzymałością.

- Ⓒ UTAHOVACÍ MOMENTY ŠROUBŮ
 Ⓓ ANZUGMOMENTE VON SCHRAUBEN
 Ⓕ COUPLES DE SERRAGE DES VIS

- Ⓖ SCREW TIGHTENING TORQUE
 Ⓡ MOMENTY ZAJATIA BOLTOB
 Ⓟ MOMENTY DOKRĘCANIA ŚRUB



- Ⓒ **OBECNÝ PŘEDPIS UTAHOVÁNÍ ZAJIŠTĚNÍ ČEPOVÝCH SPOJŮ:**
 Ⓓ **ALLGEMEINE VORSCHRIFT FÜR DAS ANZIEHEN VON BOLZENVERBINDUNGEN:**
 Ⓕ **CONSIGNE GENERALE POUR LE SERRAGE DES ARTICULATIONS CYLINDRIQUES:**
 Ⓖ **GENERAL INSTRUCTION FOR TIGHTENING THE SECURING OF PIN JOINTS:**
 Ⓡ **ОБЩЕЕ ОПИСАНИЕ ЗАЖАТИЯ ПРЕДОХРАНЕНИЯ СОЕДИНЕНИЙ ПАЛЬЦАМИ:**
 Ⓟ **OGÓLNE ZASADY DOKRĘCANIA ZABEZPIECZENIA POŁĄCZEŃ CZOPEM:**



X

M8, M10, M12

M14

M

09-15Nm

15-25Nm

- X - Ⓒ ROZMĚR ŠROUBU
 Ⓓ SCHRAUBENGRÖSSE
 Ⓕ DIMENSIONS DE LA VIS

- Ⓖ BOLT DIMENSION
 Ⓡ РАЗМЕР БОЛТА
 Ⓟ ROZMIAR ŚRUBY

- M - Ⓒ ORIENTAČNÍ MOMENT
 Ⓓ ANZUGSMOMENT
 Ⓕ COUPLE D'ORIENTATION

- Ⓖ ORIENTATION TORQUE
 Ⓡ ОРИЕНТАЦИОННЫЙ МОМЕНТ
 Ⓟ ORIENTACYJNY MOMENT

- Ⓒ Tyto spoje není nutné ověřovat kontrolou momentovým klíčem = stačí vizuálně kontrolovat sešroubování.
 Ⓓ Diese Verbindungen müssen nicht mit einem Drehmomentschlüssel überprüft werden = es genügt, die Verschraubung visuell zu kontrollieren.
 Ⓕ Il n'est pas nécessaire de contrôler le serrage à l'aide d'une clé dynamométrique = un contrôle visuel de l'assemblage suffit.
 Ⓖ These joints do not have to be verified by checking with a torque wrench = visual inspection of bolting is sufficient.
 Ⓡ Эти соединения не нужно контролировать динамометрическим ключом = достаточно визуально проверять прикручивание.
 Ⓟ Nie trzeba sprawdzać tych połączeń kluczem dynamometrycznym = wystarczy wizualnie skontrolować dokręcenie.