

ⒸZ KATALOG NÁHRADNÍCH DÍLŮ ⒸB CATALOGUE OF SPARE PARTS ⒸD ERSATZTEILLISTE
ⒸRU КАТАЛОГ ЗАПАСНЫХ ЧАСТЕЙ ⒸF CATALOGUE DES PIÈCES DE RECHANGE ⒸPL KATALOG CZĘŚCI ZAMIENNYCH

SOFTER 8 PS

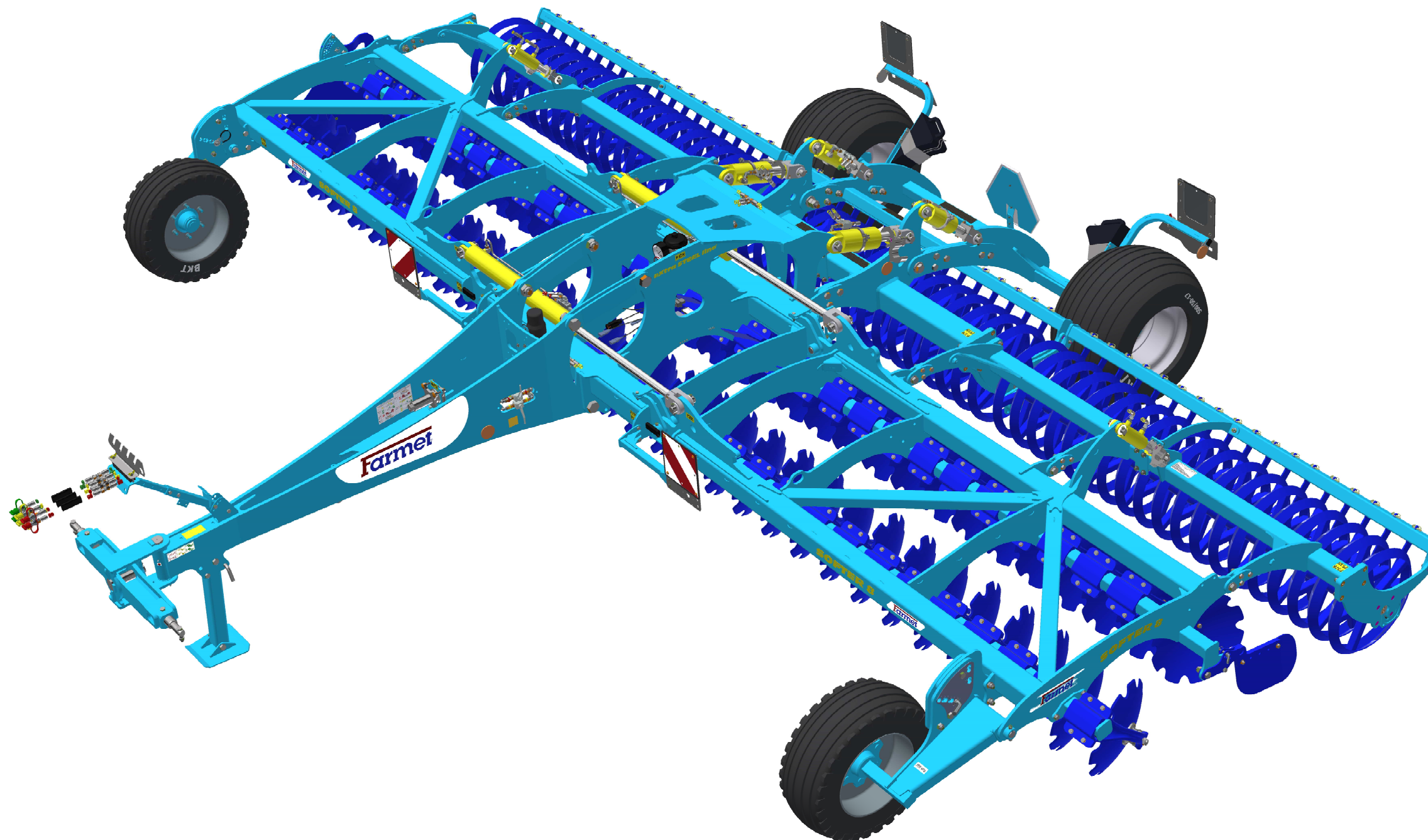

ⒸZ Platnost pro vrcholové | výrobní číslo stroje ⒸB Validity for the top | serial number of the machine
ⒸD Gültigkeit für die Haupt- | Herstellungsnummer der Maschine ⒸRU Действительно для главного | заводского номера машины
ⒸF Validité du numéro de référence | de série de la machine ⒸPL Obowiązuje dla numeru głównego | seryjnego maszyny

9336280 | 2024/0374

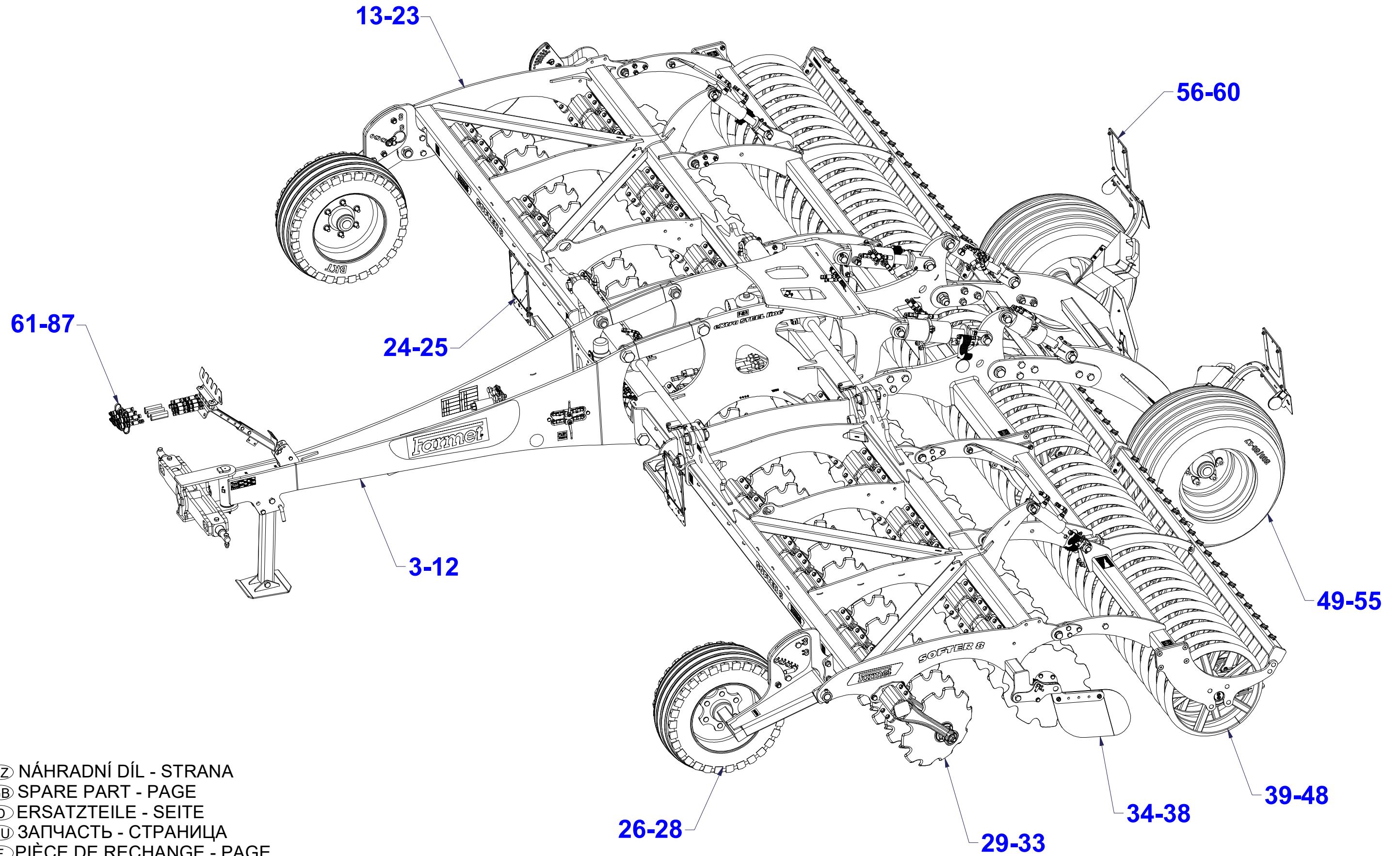

ⒸZ OJ MONT

Ⓓ DEICHSEL MONTIERT

Ⓕ TIMON MONTÉ

VZ00037577

ⒼB MONT DRAWBAR

ⒺU ДЫШЛО МОНТ

ⒽL DYSZEL MONT

Farmet

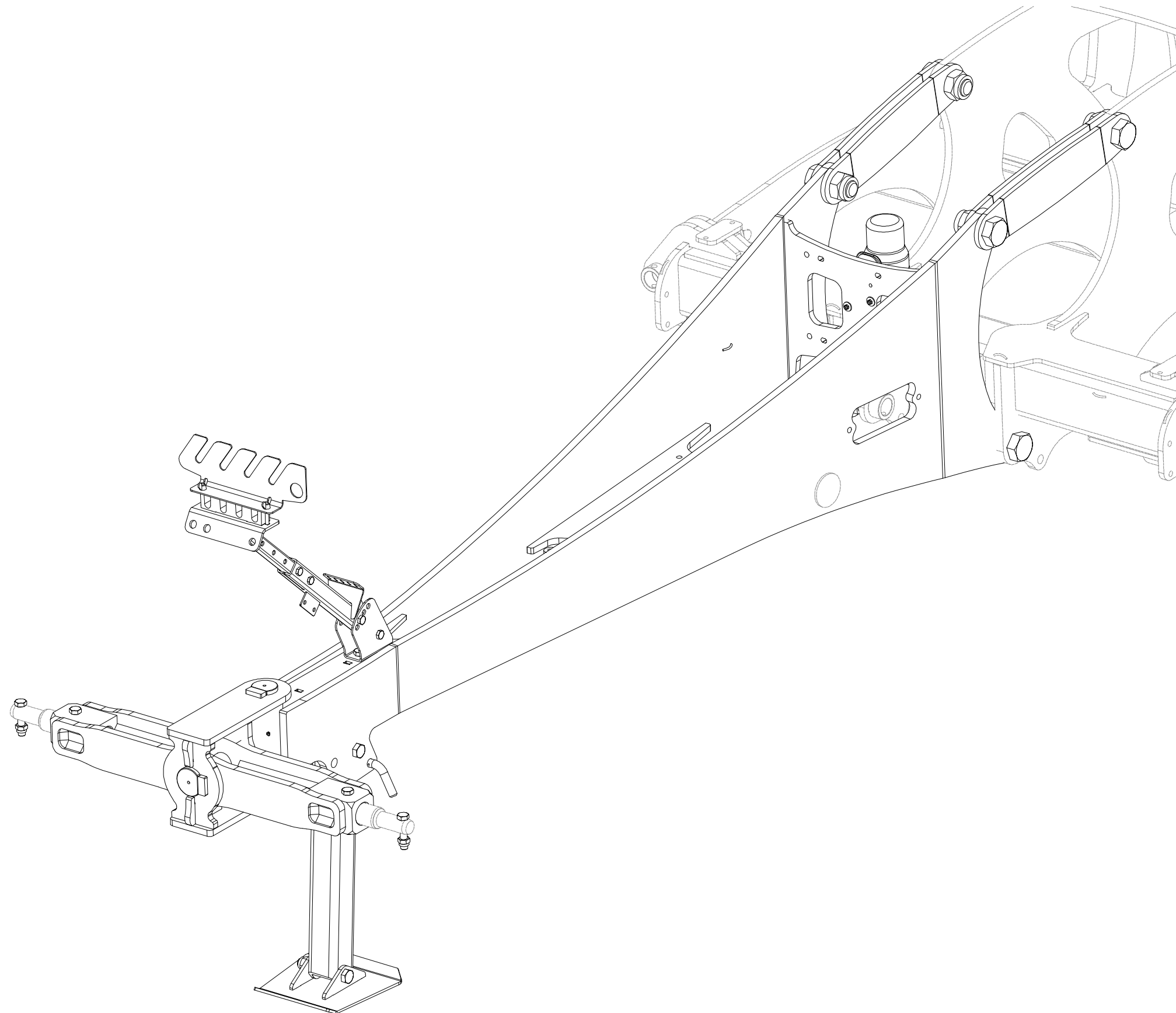

ⒸZ OJ MONT

Ⓓ DEICHSEL MONTIERT

Ⓕ TIMON MONTÉ

ⒼB MONT DRAWBAR

ⓇU ДЫШЛО МОНТ

ⓅL DYSZEL MONT



VZ00037577

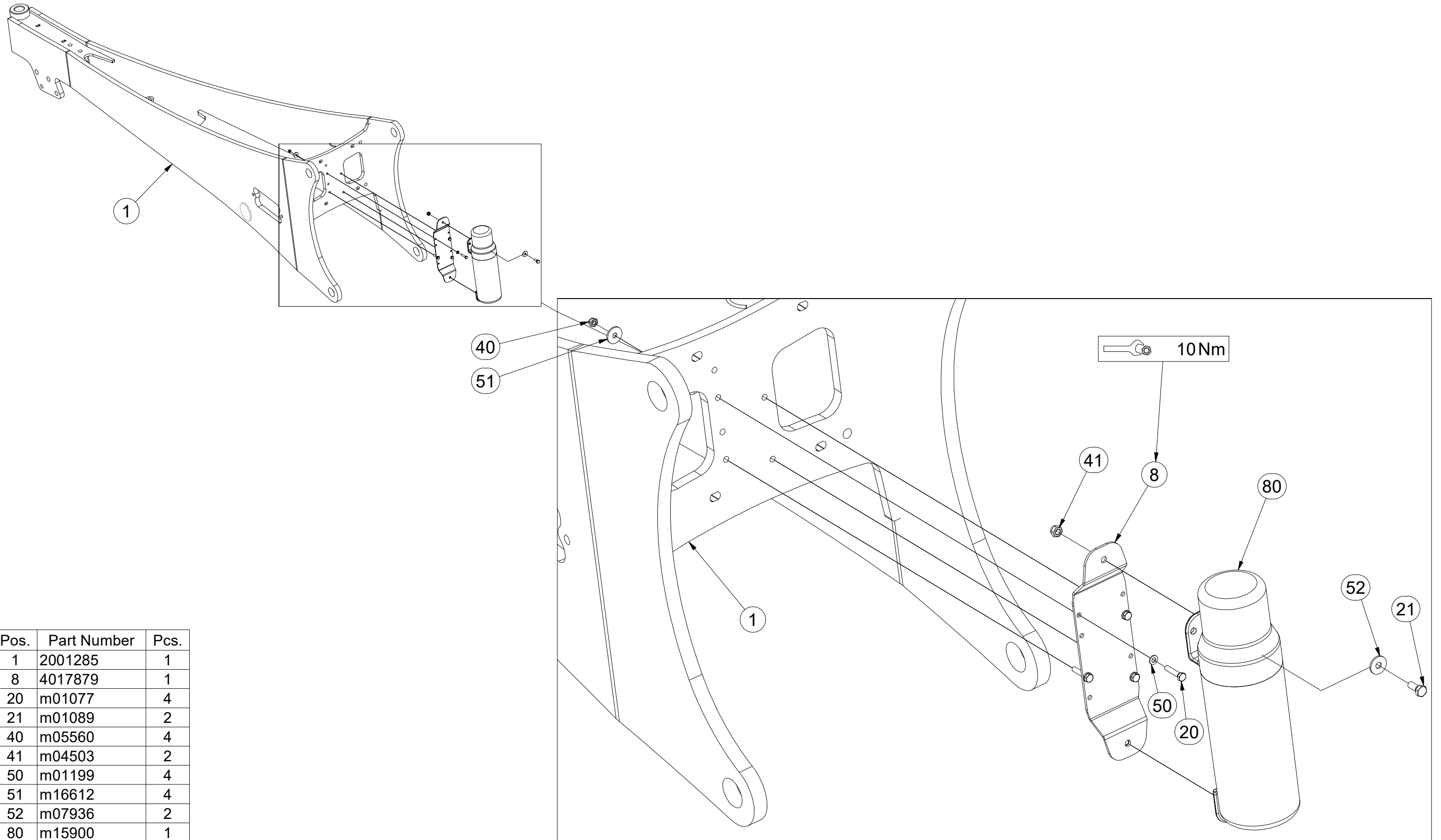

Pos.	Part Number	Pcs.
1	2001285	1
8	4017879	1
20	m01077	4
21	m01089	2
40	m05560	4
41	m04503	2
50	m01199	4
51	m16612	4
52	m07936	2
80	m15900	1

ⒸZ OJ MONT

Ⓓ DEICHSEL MONTIERT

Ⓕ TIMON MONTÉ

VZ00037577

ⒸGB MONT DRAWBAR

ⒸRU ДЫШЛО МОНТ

ⒸPL DYSZEL MONT

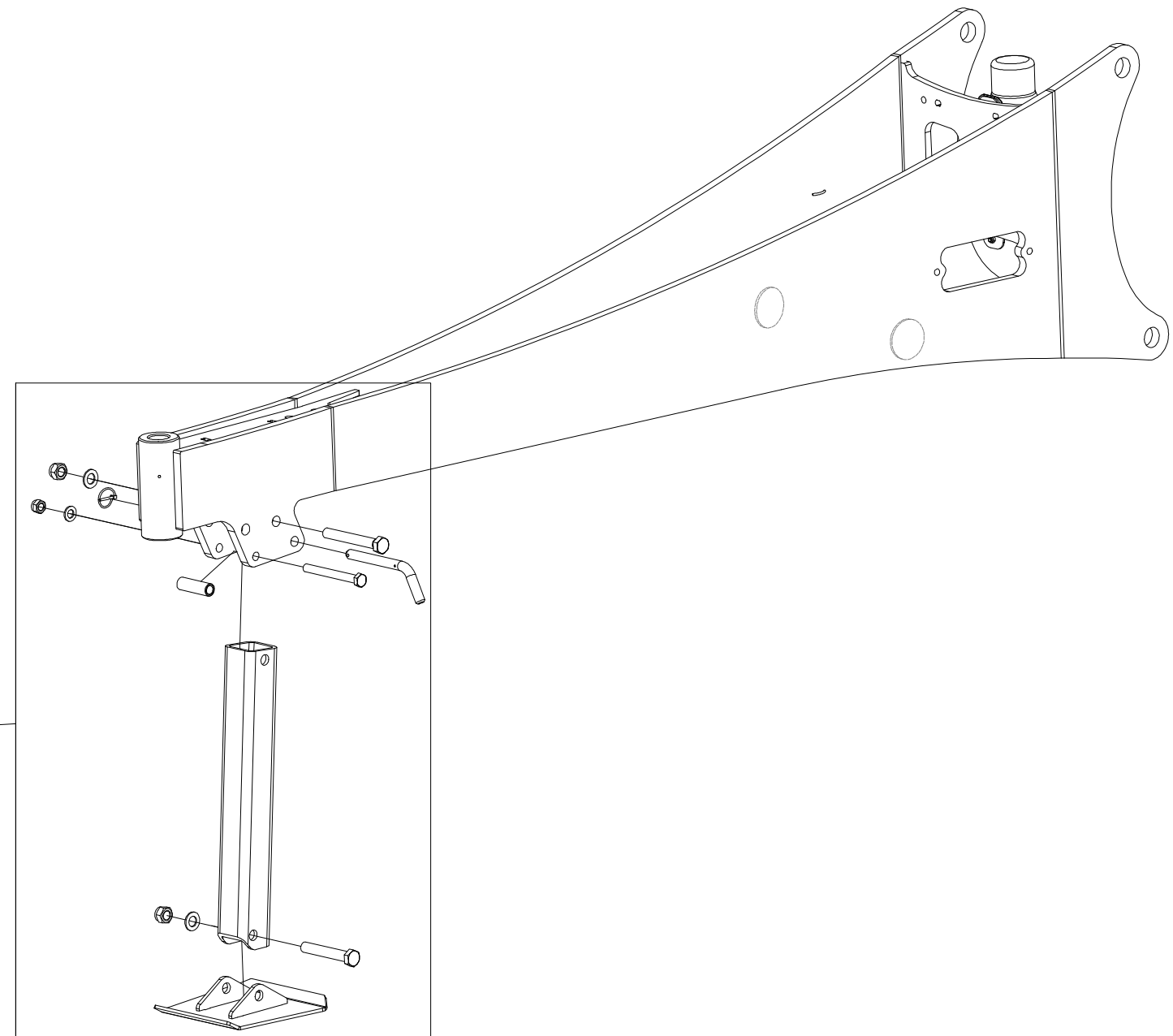
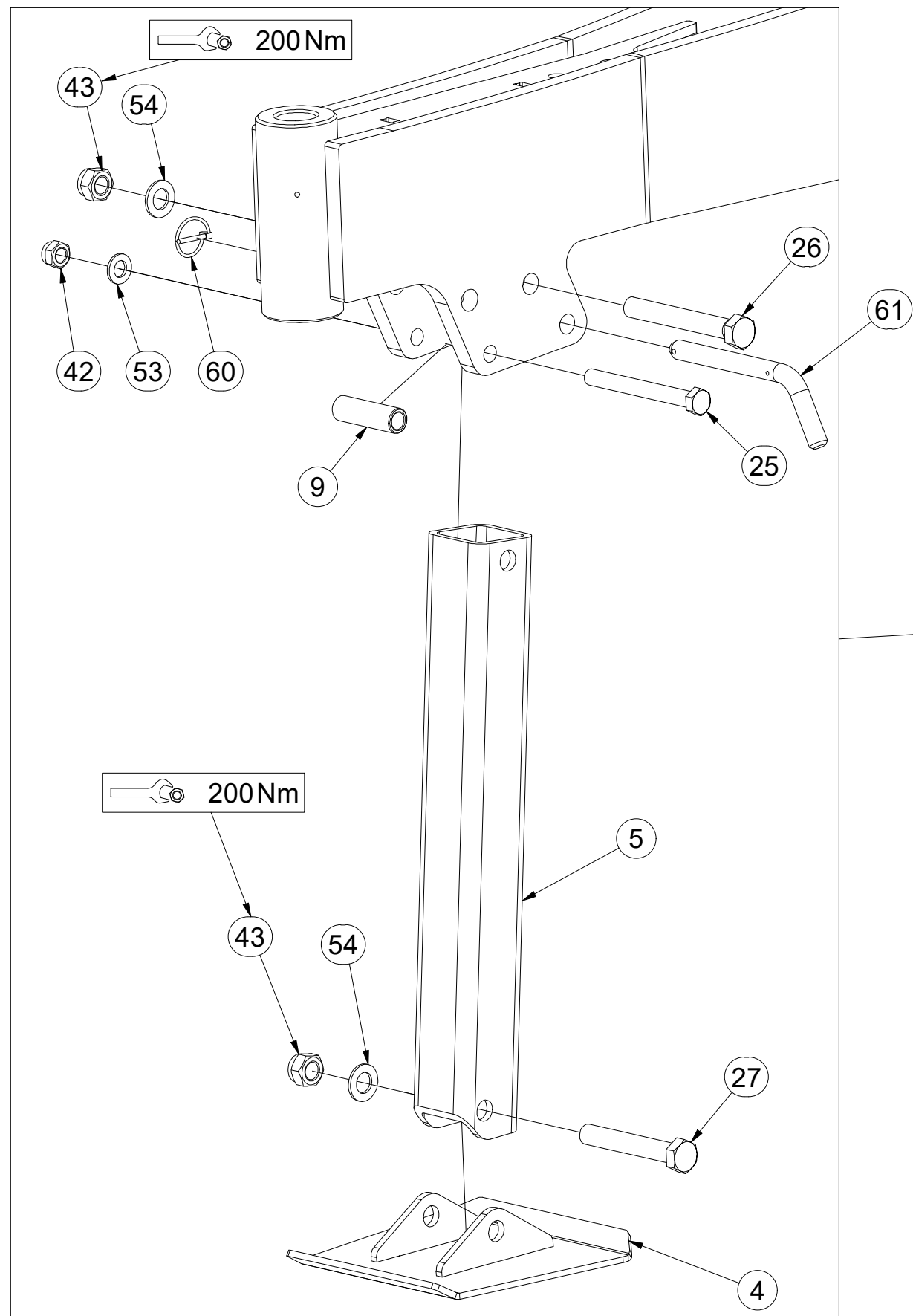

Pos.	Part Number	Pcs.
4	4007000	1
5	4006699	1
9	4004007	1
25	m04936	1
26	m05345	1
27	m05465	1
42	m03683	7
43	m05648	2
53	m01219	1
54	m03768	2
60	m10454	1
61	m18629	1

ⒸZ OJ MONT

Ⓓ DEICHSEL MONTIERT

Ⓕ TIMON MONTÉ

VZ00037577

ⒼB MONT DRAWBAR

Ⓔ RU ДЫШЛО МОНТ

ⒼL DYSZEL MONT

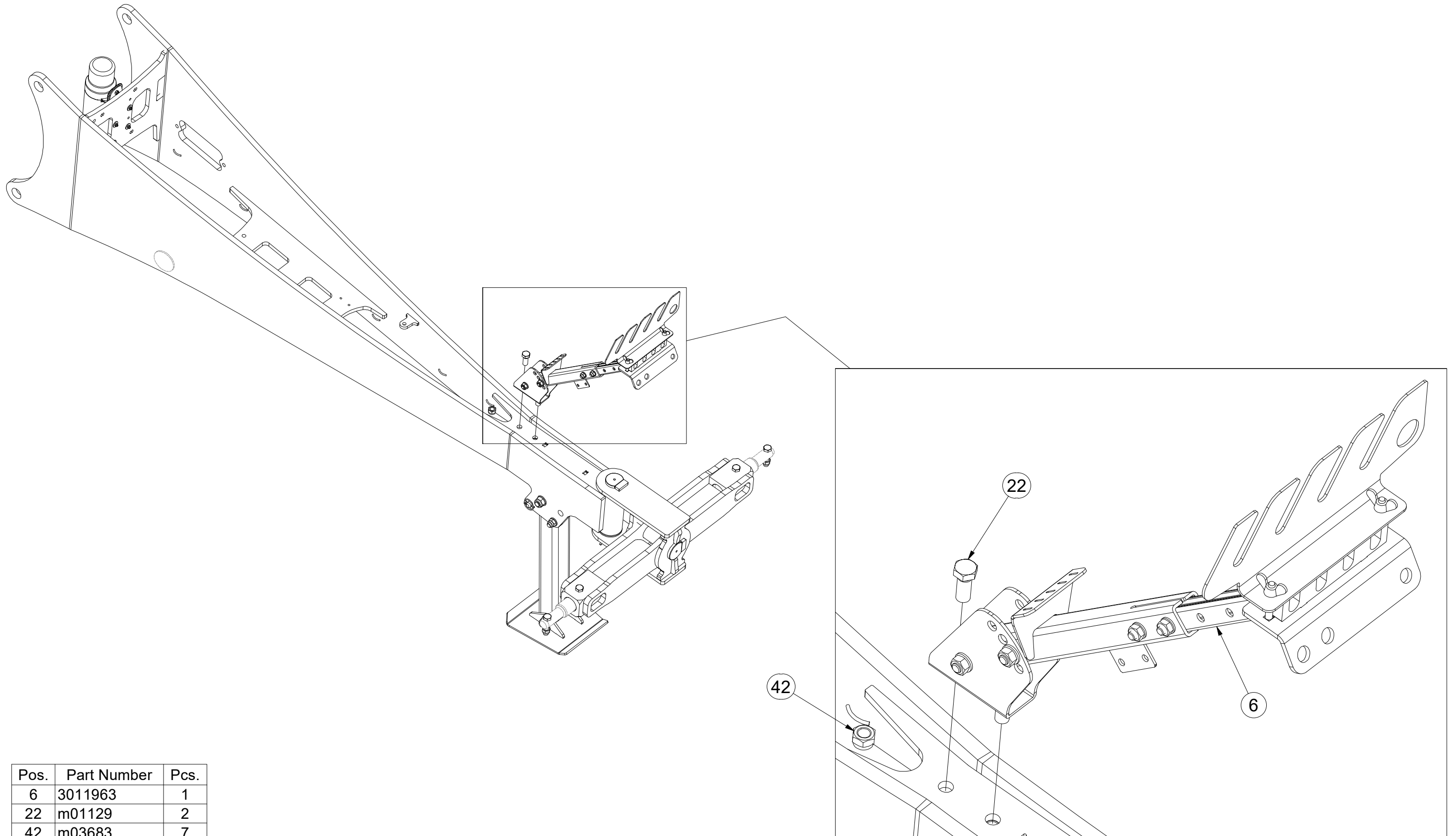

Pos.	Part Number	Pcs.
6	3011963	1
22	m01129	2
42	m03683	7

CZ OJ MONT
 D DEICHSEL MONTIERT
 F TIMON MONTÉ

GB MONT DRAWBAR
 RU ДЫШЛО МОНТ
 PL DYSZEL MONT



VZ00037577

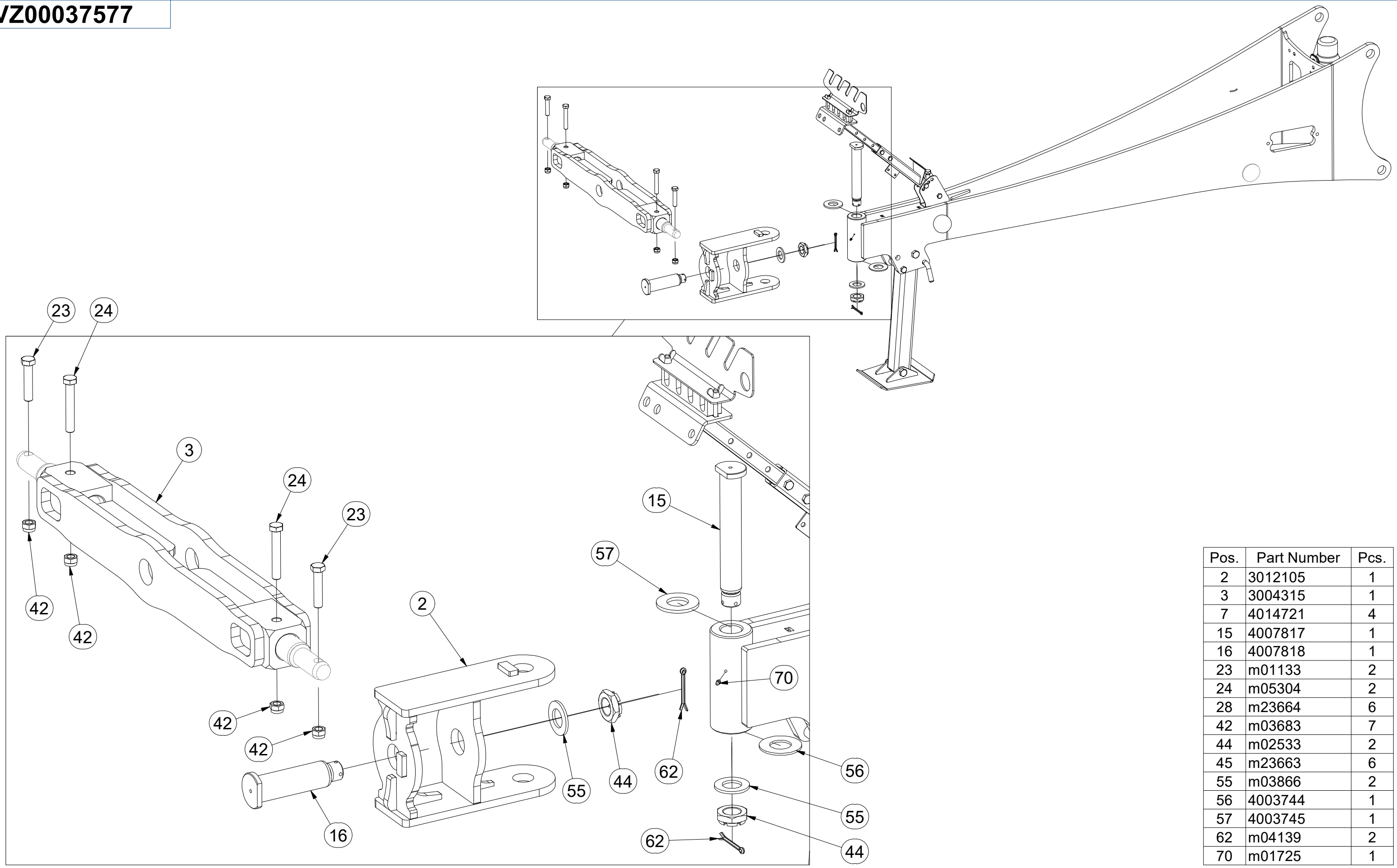

Pos.	Part Number	Pcs.
2	3012105	1
3	3004315	1
7	4014721	4
15	4007817	1
16	4007818	1
23	m01133	2
24	m05304	2
28	m23664	6
42	m03683	7
44	m02533	2
45	m23663	6
55	m03866	2
56	4003744	1
57	4003745	1
62	m04139	2
70	m01725	1

ⒸZ OJ MONT

Ⓓ DEICHSEL MONTIERT

Ⓕ TIMON MONTÉ

ⒼB MONT DRAWBAR

ⒺU ДЫШЛО МОНТ

ⒼL DYSZEL MONT



VZ00037577

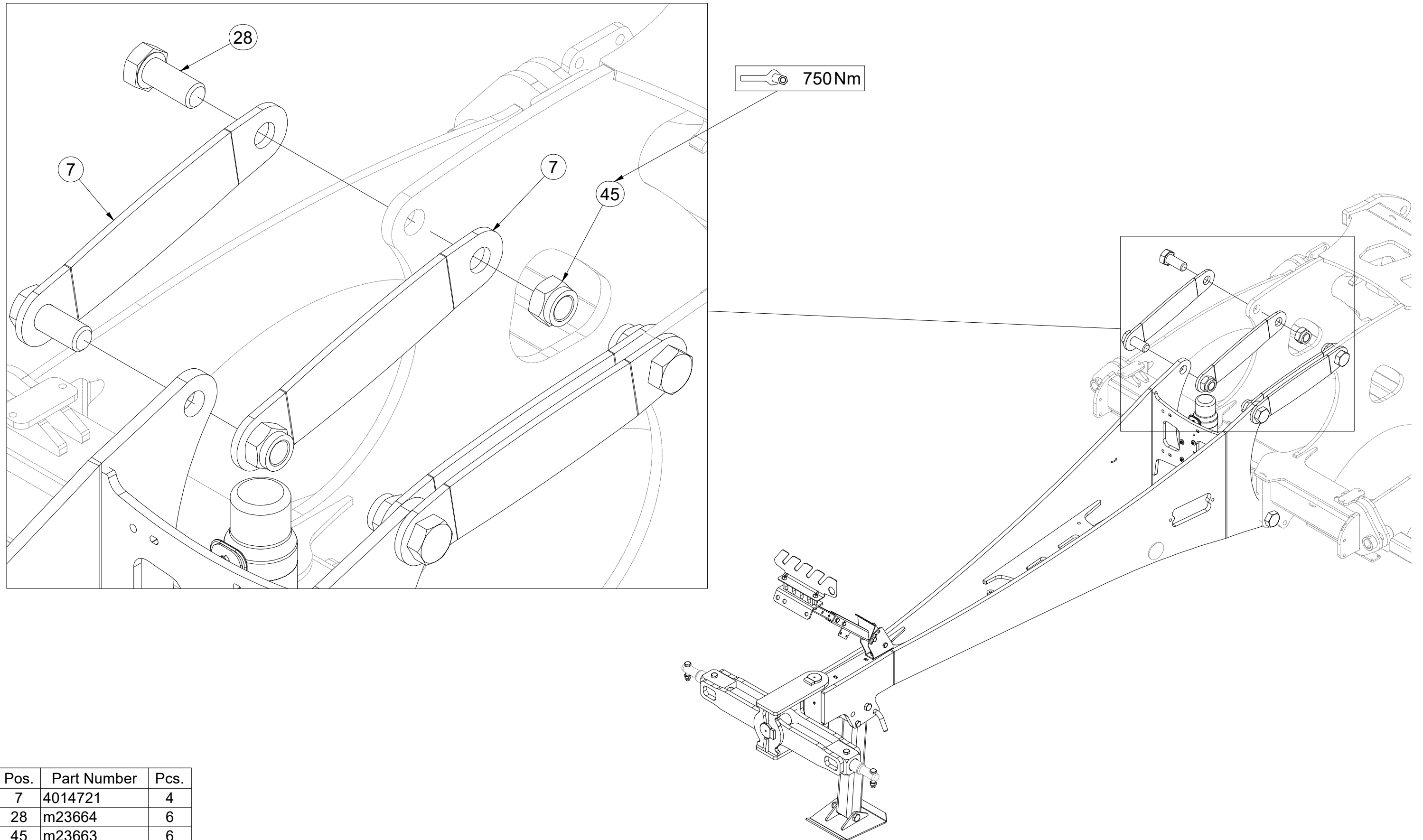

Pos.	Part Number	Pcs.
7	4014721	4
28	m23664	6
45	m23663	6

CZ TELESKOPICKÝ DRŽÁK HADIC
 D TELESKOPSCHLAUCHHALTER
 F SUPPORT DE TUYAU TÉLESCOPIQUE

GB TELESCOPIC HOSE HOLDER
 RU ТЕЛЕСКОПИЧЕСКИЙ ДЕРЖАТЕЛЬ ШЛАНГА
 PL TELESKOPOWY UCHWYT NA WĄŻ



3011963

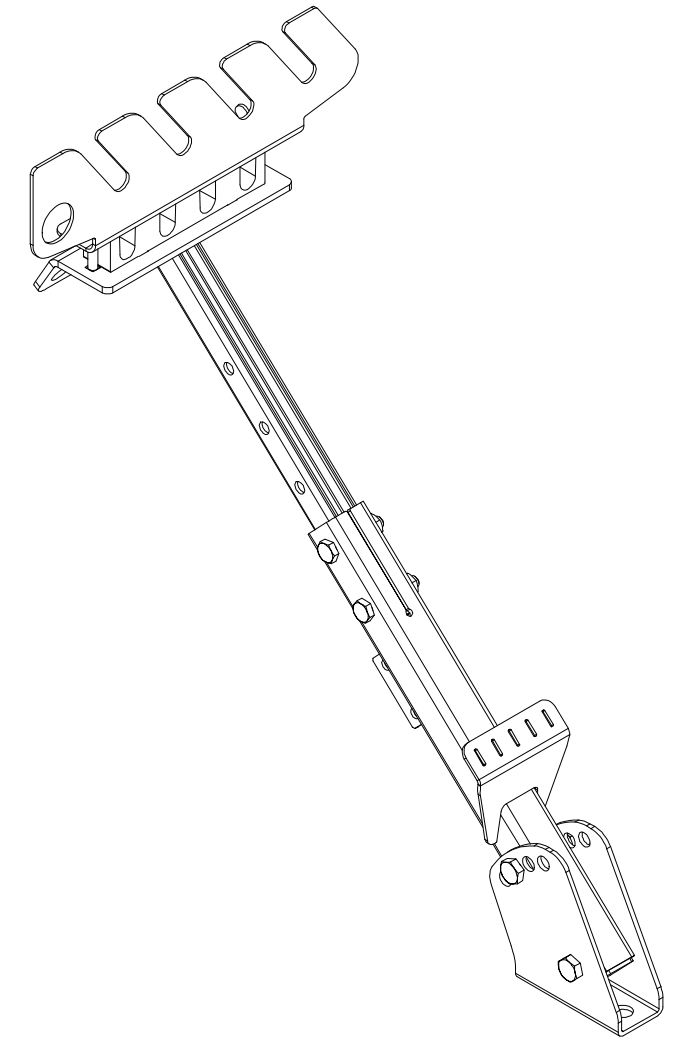
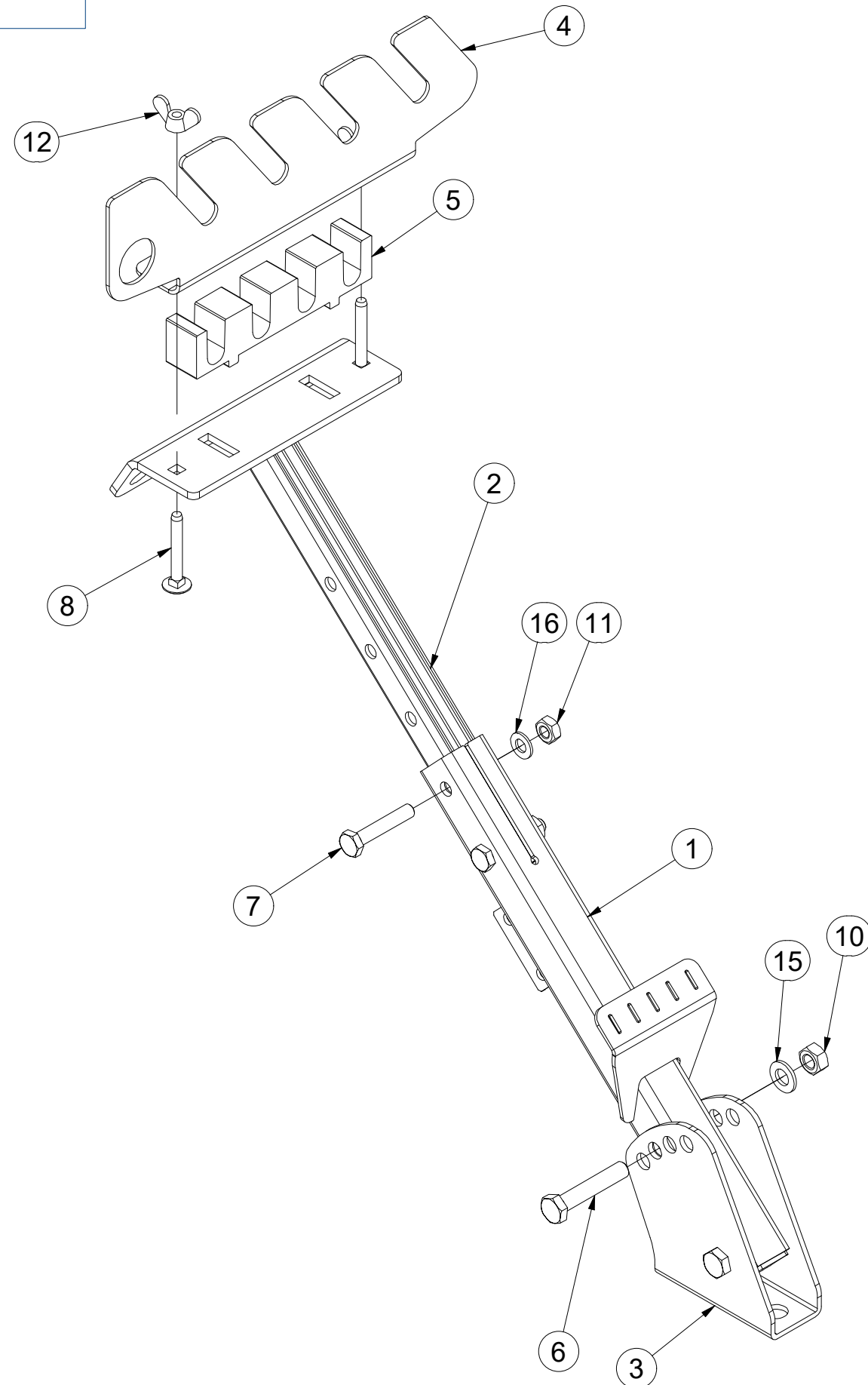

Pos.	Part Number	Pcs.
1	3011662	1
2	3011689	1
3	3011659	1
4	4023572	1
5	m22642	1
6	m05898	2
7	m06253	2
8	m09247	2
10	m01305	2
11	m01299	2
12	m01316	2
15	m01214	2
16	m01209	2

ⒸZ TÁHLO

Ⓓ STANGE

Ⓕ TIGE DE TRACTION

VZ00006988

ⒼB DRAWBAR

Ⓔ RU ТЯГА

Ⓗ PL PRĘT

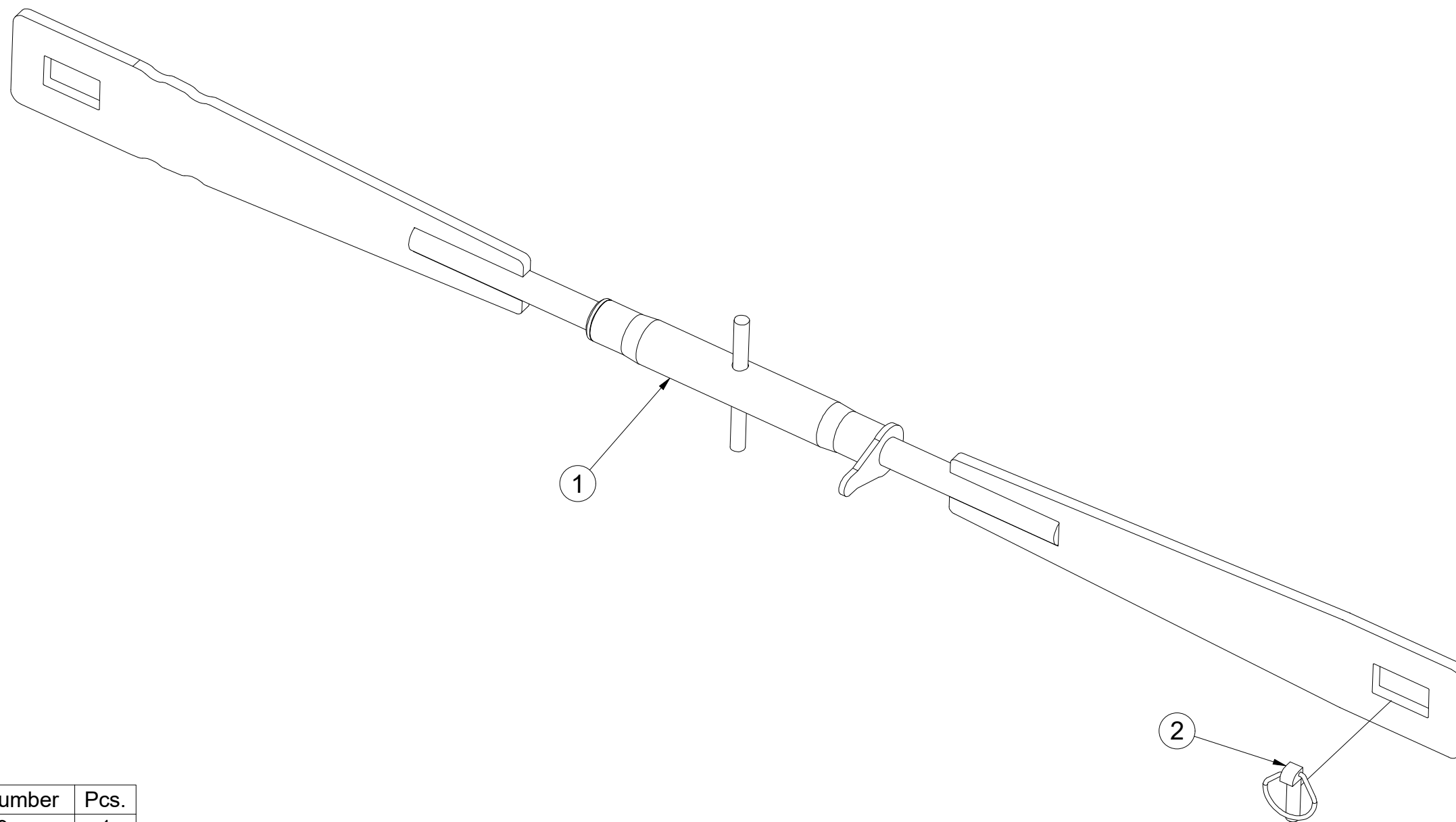

Pos.	Part Number	Pcs.
1	4009359	1
2	m02505	1

Ⓒ SPOJOVACÍ TÁHLO
Ⓓ VERBINDUNGSSTANGE
Ⓕ TIGE DE RACCORDEMENT

Ⓖ CONNECTING ROD
Ⓡ СОЕДИНИТЕЛЬНАЯ ТЯГА
Ⓟ KORBOWÓD



4009359

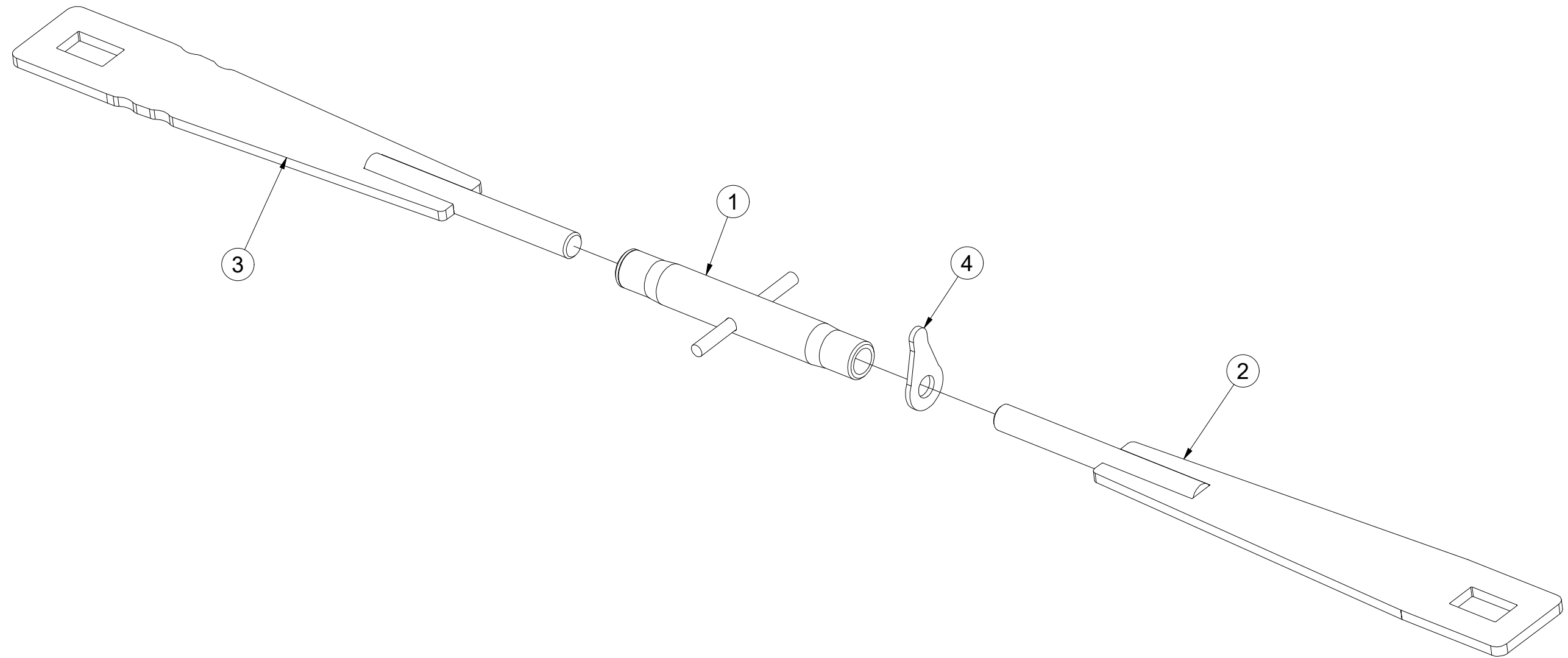

Pos.	Part Number	Pcs.
1	m08880	1
2	4009356	1
3	4009360	1
4	m08881	1

Ⓒ SADA ČEPŮ TBZ 3

Ⓓ BOLZENSATZ TBZ 3

Ⓕ KIT D'EMBOUITS TBZ 3

4020780

Ⓖ SET OF TBZ 3 PINS

Ⓡ КОМПЛЕКТ ПАЛЬЦЕВ TBZ 3

Ⓟ ZESTAW CZOPÓW TBZ 3

Farmet

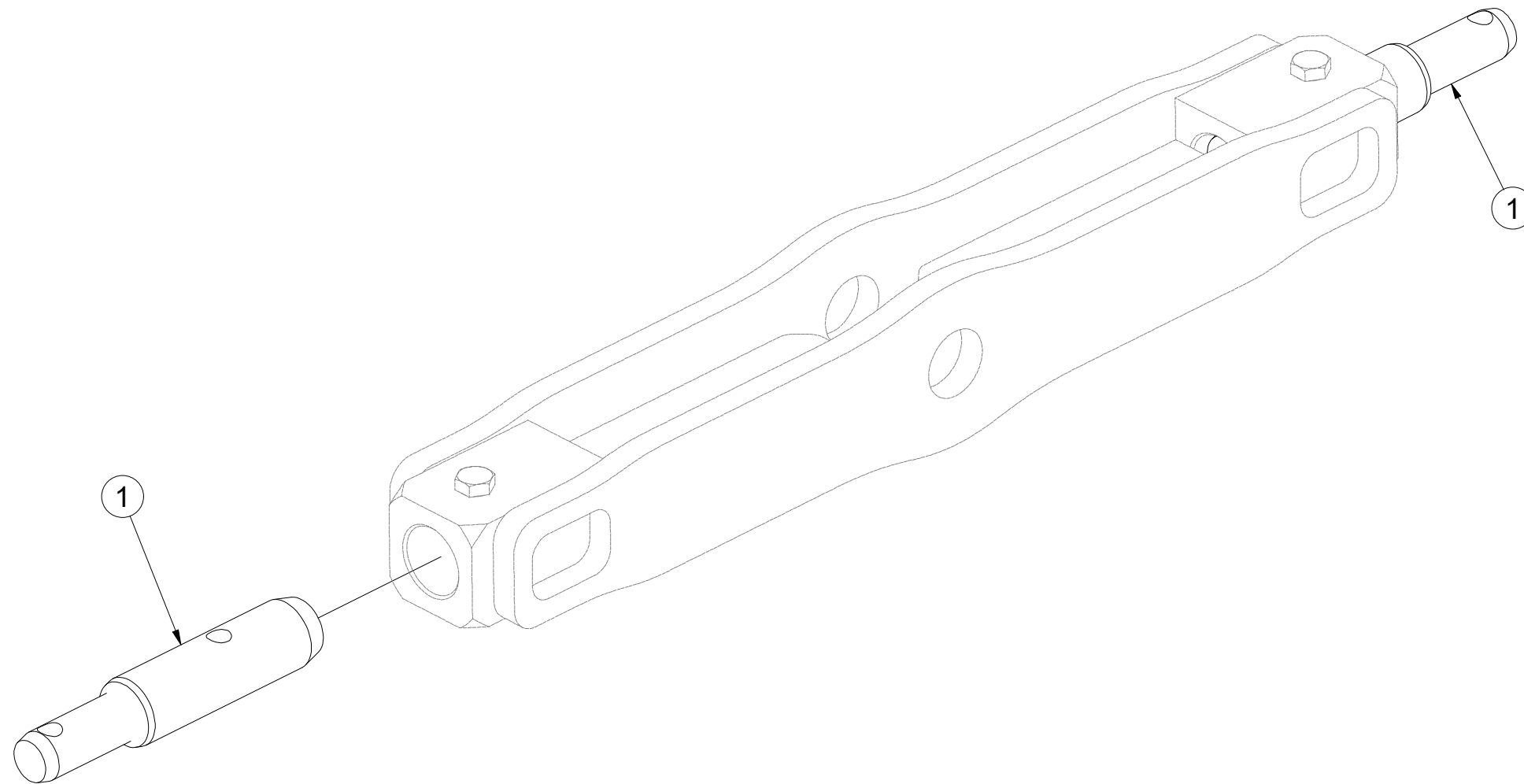

Pos.	Part Number	Pcs.
1	VZ00022883	2

☉ ZÁKLAD STROJE

☐ UNTERBAU DER MASCHINE

☉ BÂTI DE LA MACHINE

VZ00037149

☉ FOOTING OF THE MACHINE

☉ ОСНОВАНИЕ МАШИНЫ

☉ PODSTAWA MASZYNY

Farmet

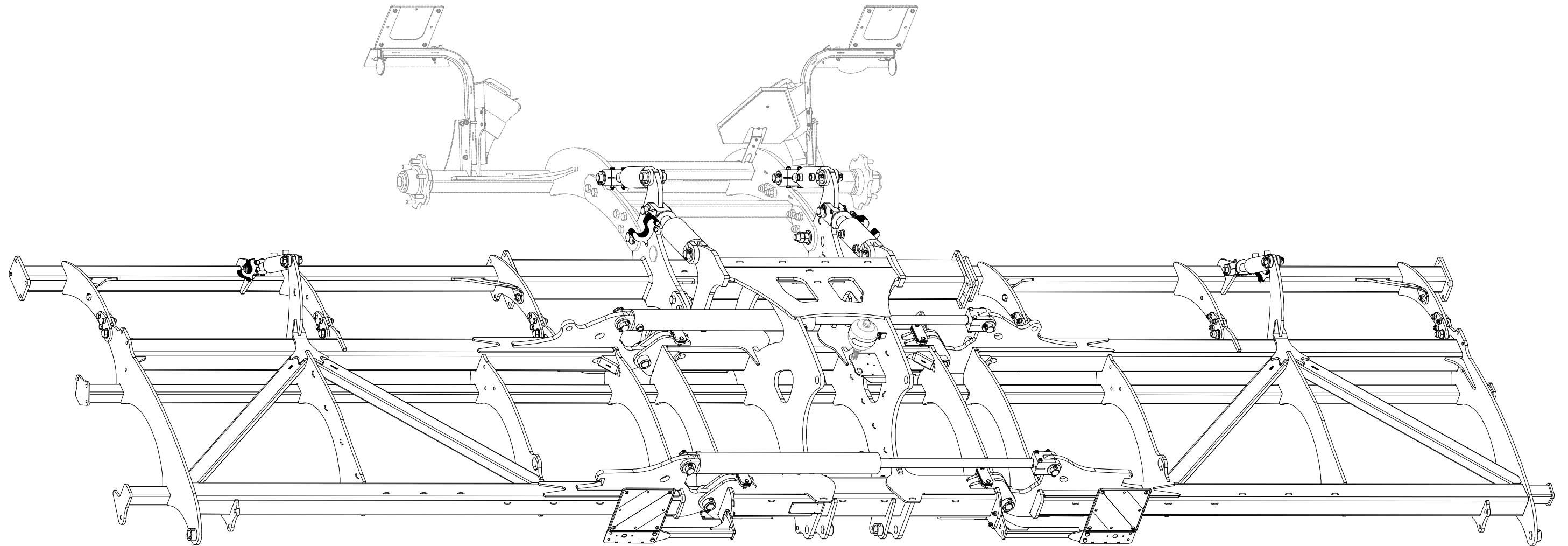

Ⓒ ZÁKLAD STROJE

Ⓓ UNTERBAU DER MASCHINE

Ⓕ BÂTI DE LA MACHINE

VZ00037149

Ⓖ FOOTING OF THE MACHINE

Ⓡ ОСНОВАНИЕ МАШИНЫ

Ⓟ PODSTAWA MASZYNY

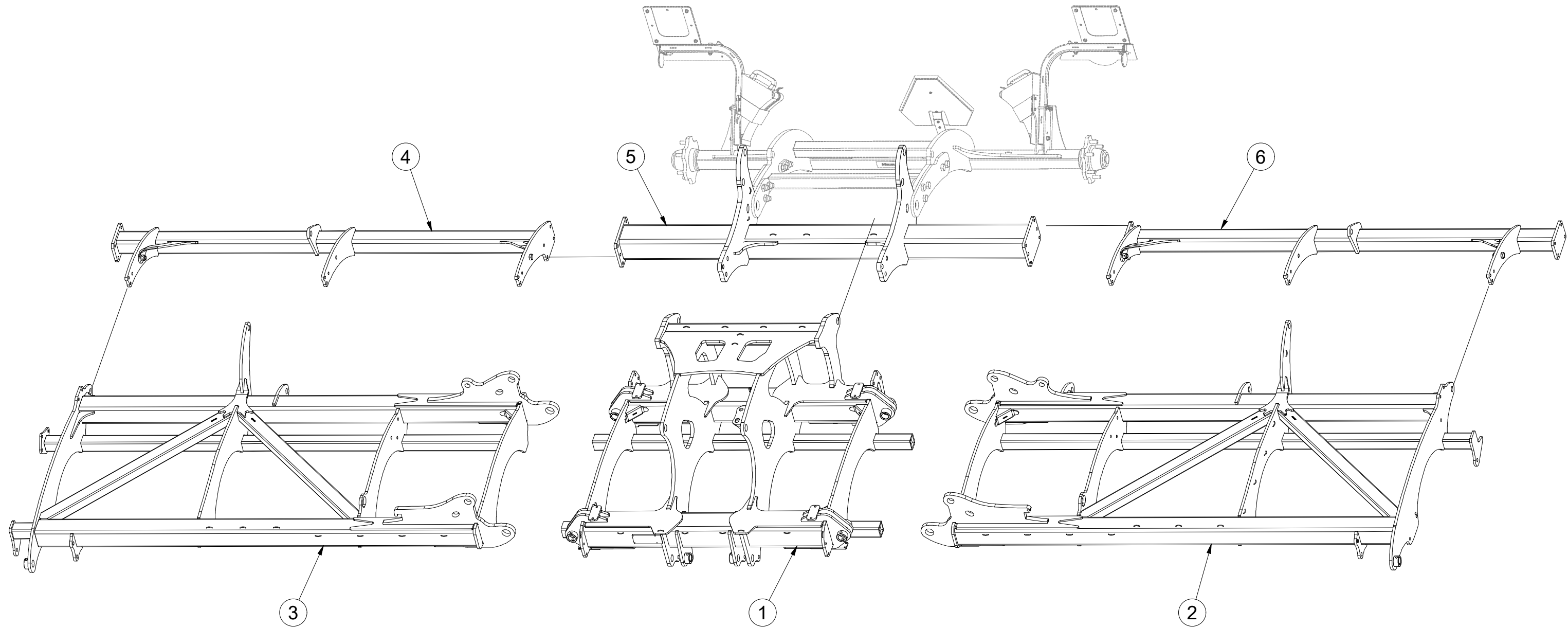

Pos.	Part Number	Pcs.
1	1000587	1
2	2001276	1
3	VZ00030337	1
4	3008715	1
5	3008716	1
6	3008714	1

Ⓒ ZÁKLAD STROJE

Ⓓ UNTERBAU DER MASCHINE

Ⓕ BÂTI DE LA MACHINE

Ⓖ FOOTING OF THE MACHINE

Ⓡ ОСНОВАНИЕ МАШИНЫ

Ⓢ PODSTAWA MASZyny



VZ00037149

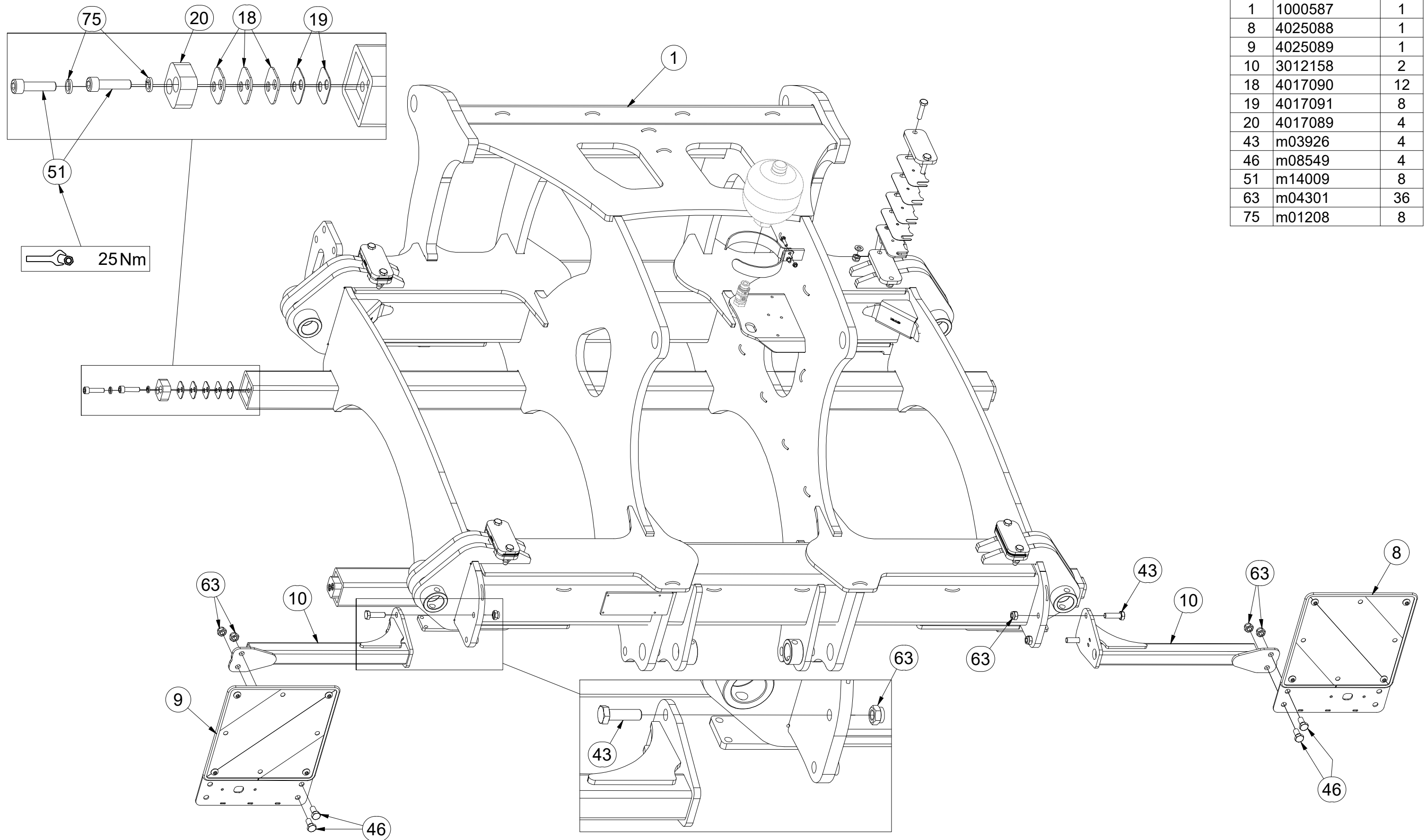

Pos.	Part Number	Pcs.
1	1000587	1
8	4025088	1
9	4025089	1
10	3012158	2
18	4017090	12
19	4017091	8
20	4017089	4
43	m03926	4
46	m08549	4
51	m14009	8
63	m04301	36
75	m01208	8

Ⓒ ZÁKLAD STROJE

Ⓓ UNTERBAU DER MASCHINE

Ⓕ BÂTI DE LA MACHINE

Ⓖ FOOTING OF THE MACHINE

Ⓡ ОСНОВАНИЕ МАШИНЫ

Ⓟ PODSTAWA MASZYNY



VZ00037149

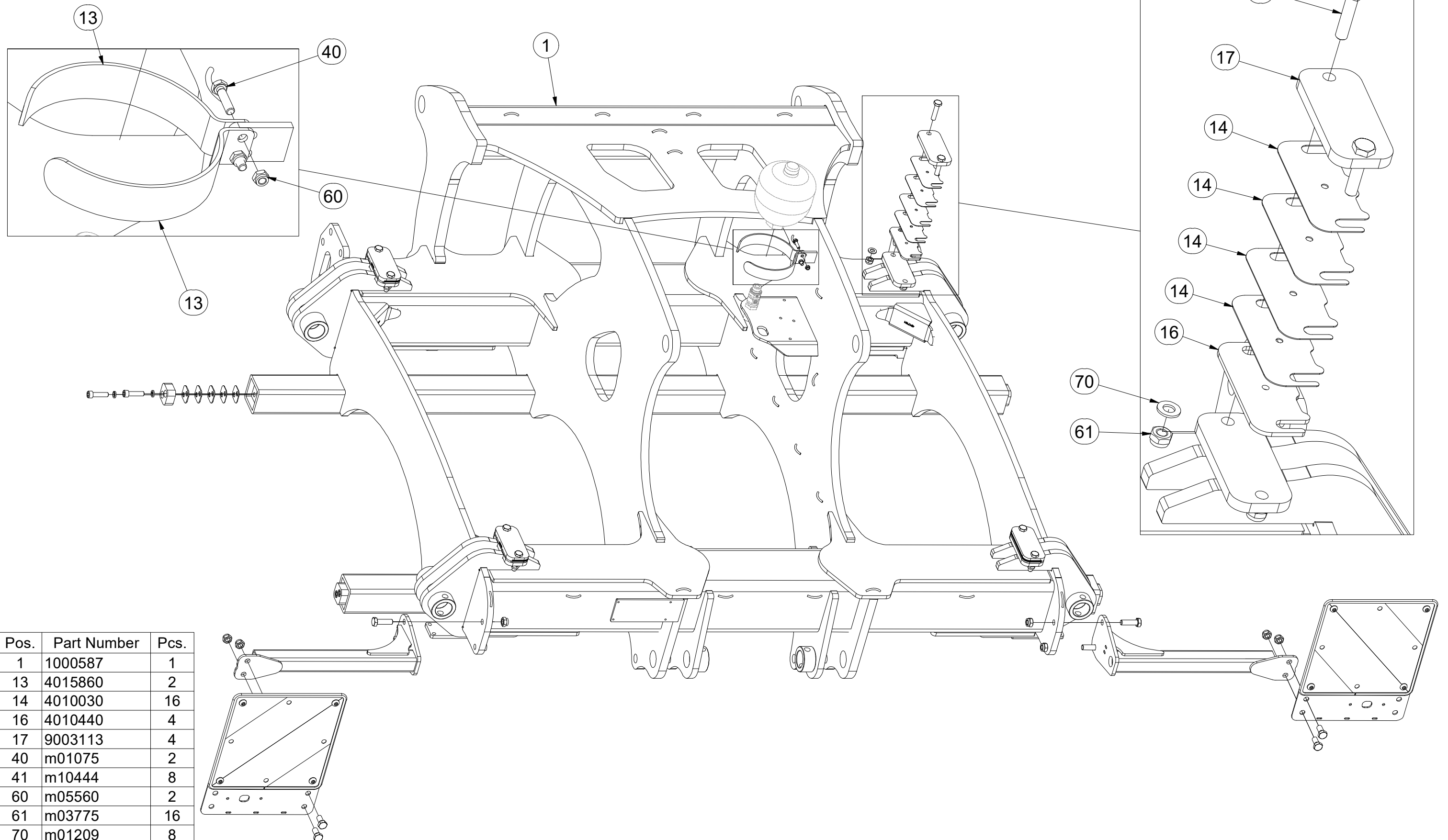

Pos.	Part Number	Pcs.
1	1000587	1
13	4015860	2
14	4010030	16
16	4010440	4
17	9003113	4
40	m01075	2
41	m10444	8
60	m05560	2
61	m03775	16
70	m01209	8

Ⓒ ZÁKLAD STROJE

Ⓓ UNTERBAU DER MASCHINE

Ⓕ BÂTI DE LA MACHINE

VZ00037149

Ⓖ FOOTING OF THE MACHINE

Ⓡ ОСНОВАНИЕ МАШИНЫ

Ⓢ PODSTAWA MASZYNY

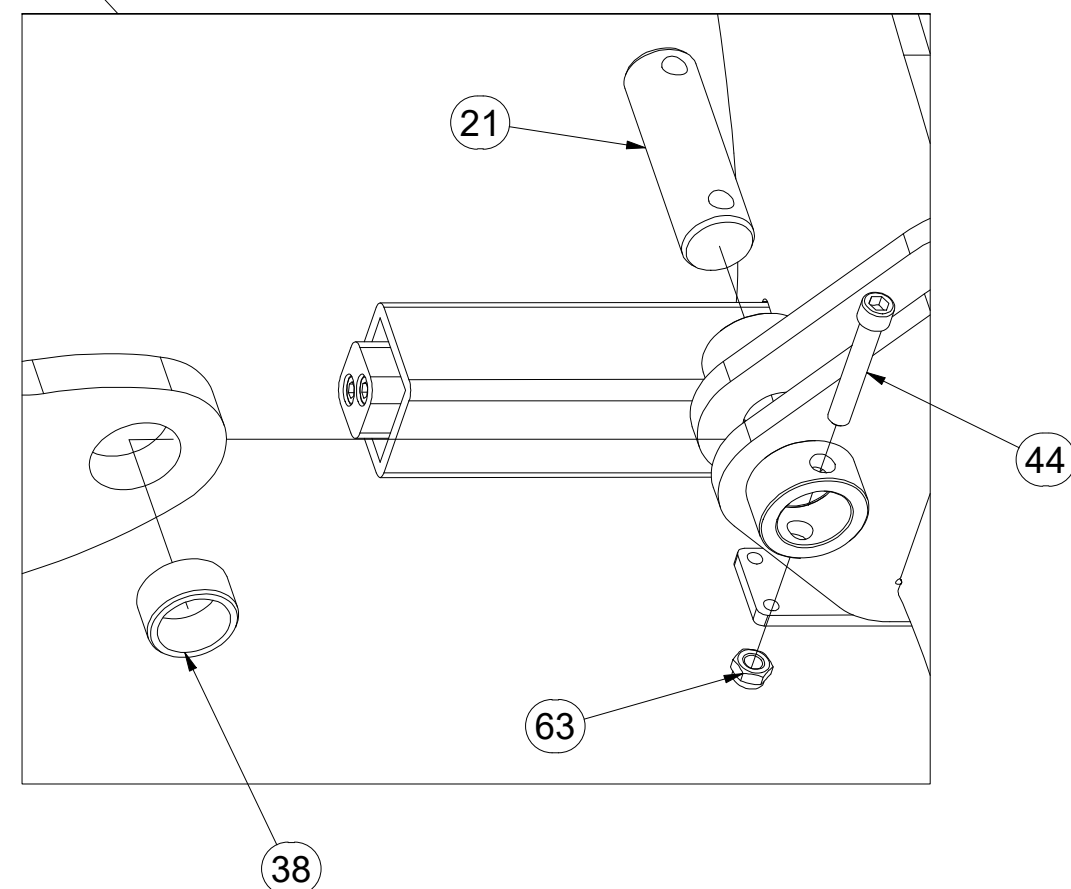
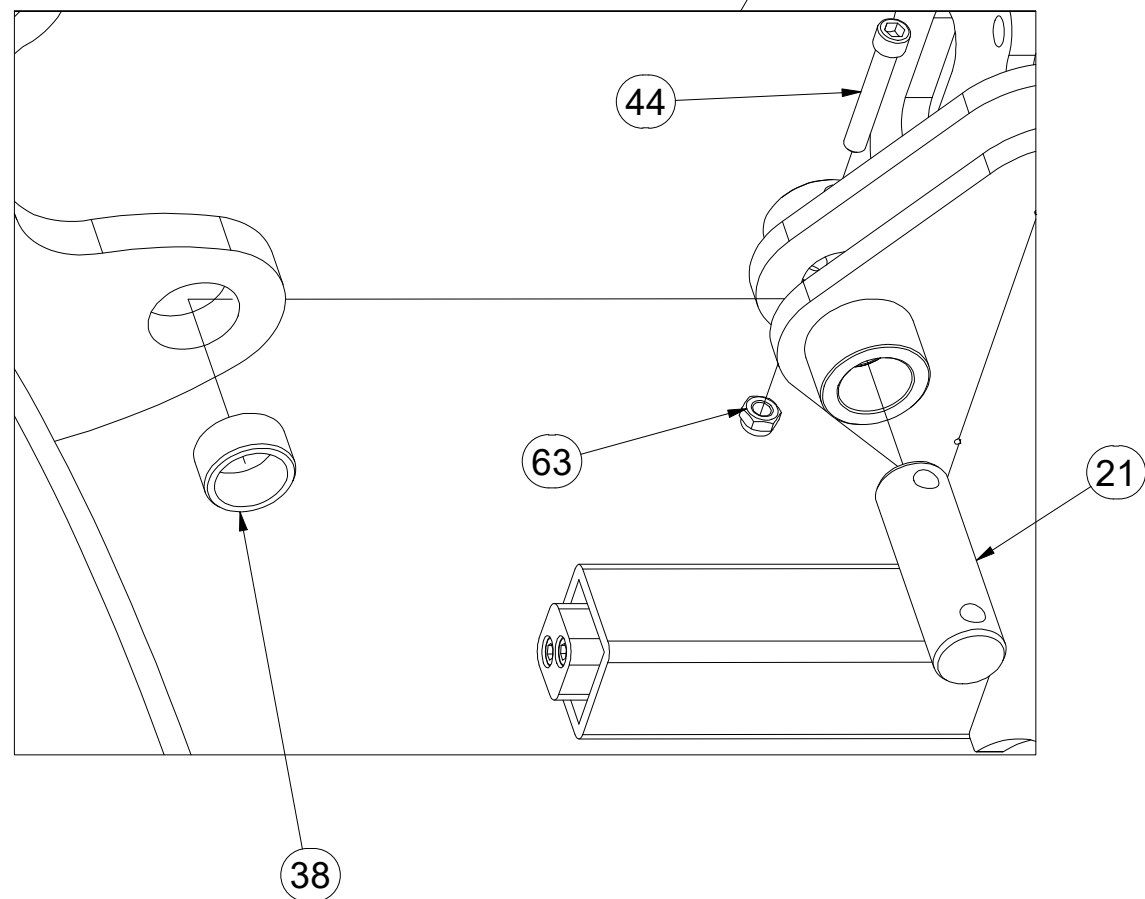
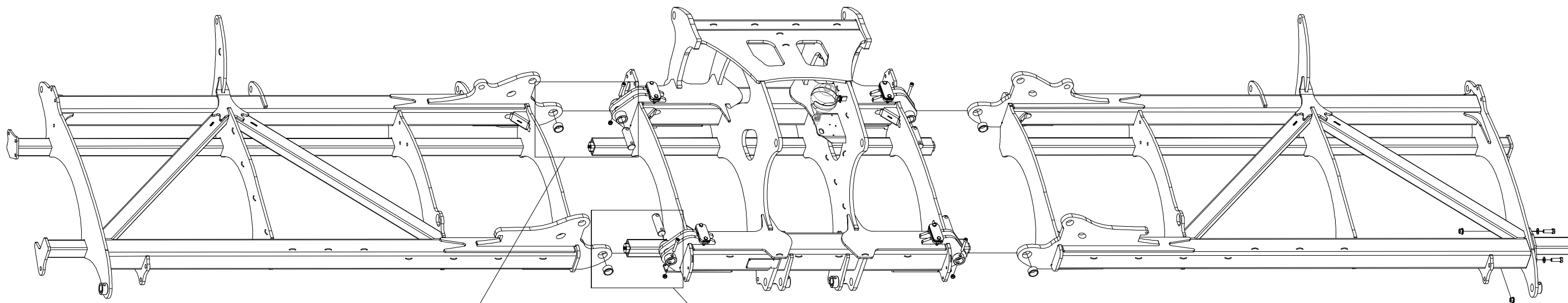

Pos.	Part Number	Pcs.
21	4007816	8
38	m15002	4
44	m13033	4
63	m04301	36

Ⓒ ZÁKLAD STROJE

Ⓓ UNTERBAU DER MASCHINE

Ⓕ BÂTI DE LA MACHINE

Ⓖ FOOTING OF THE MACHINE

Ⓡ ОСНОВАНИЕ МАШИНЫ

Ⓢ PODSTAWA MASZyny



VZ00037149

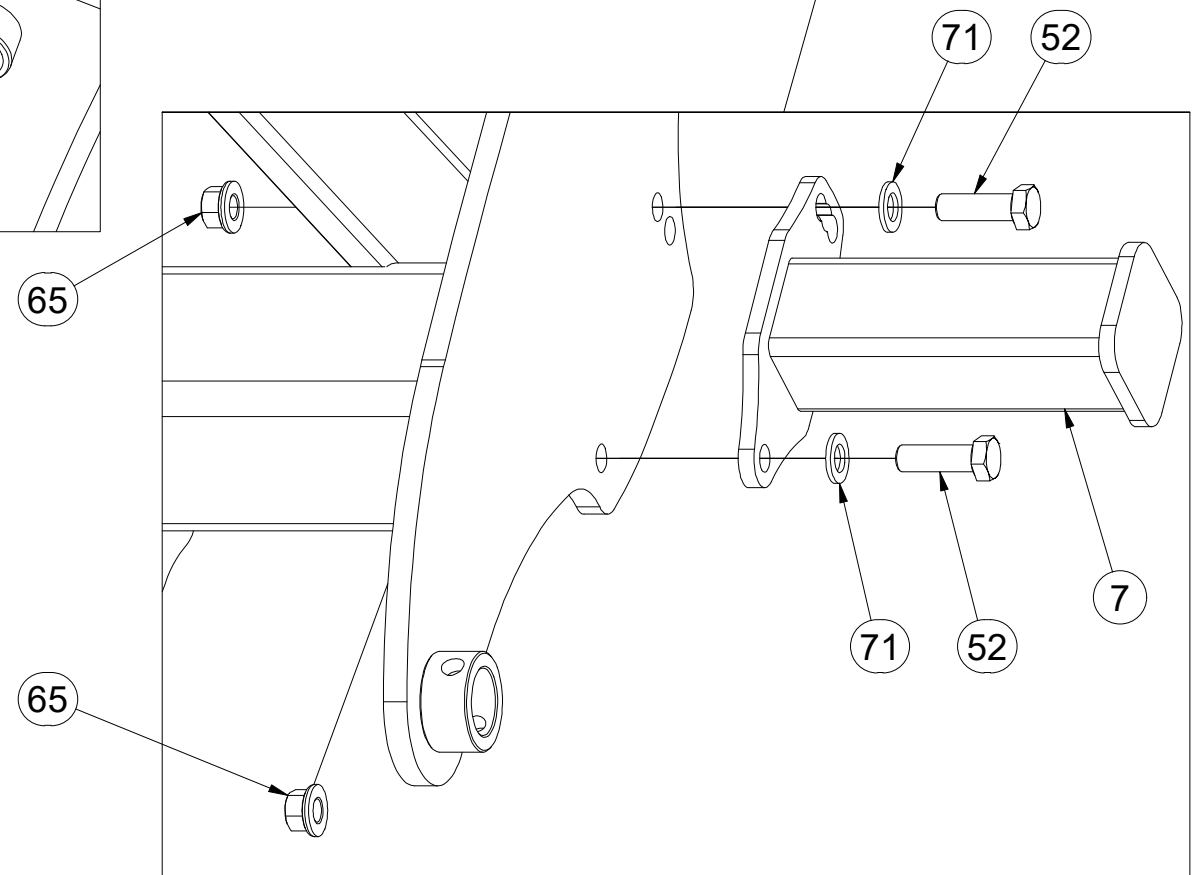
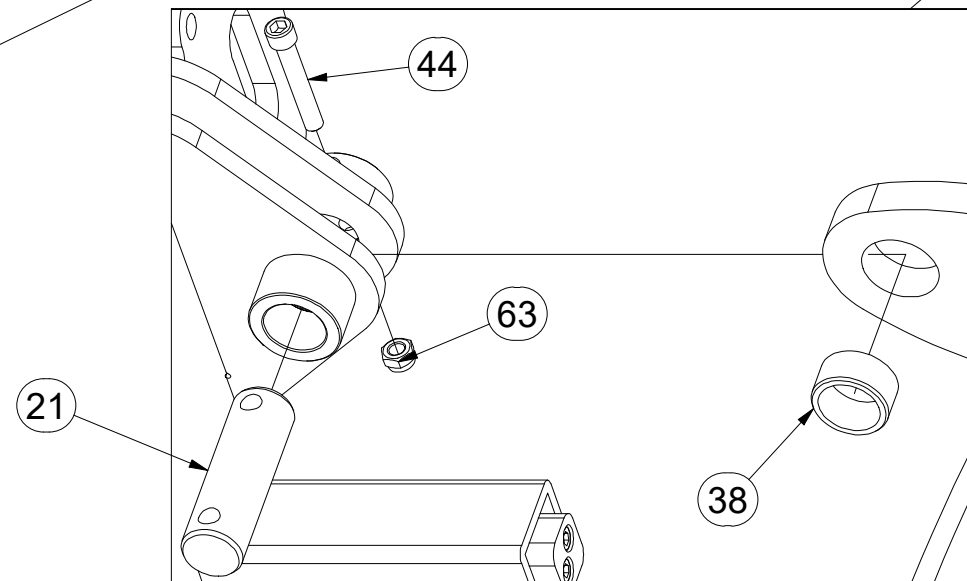
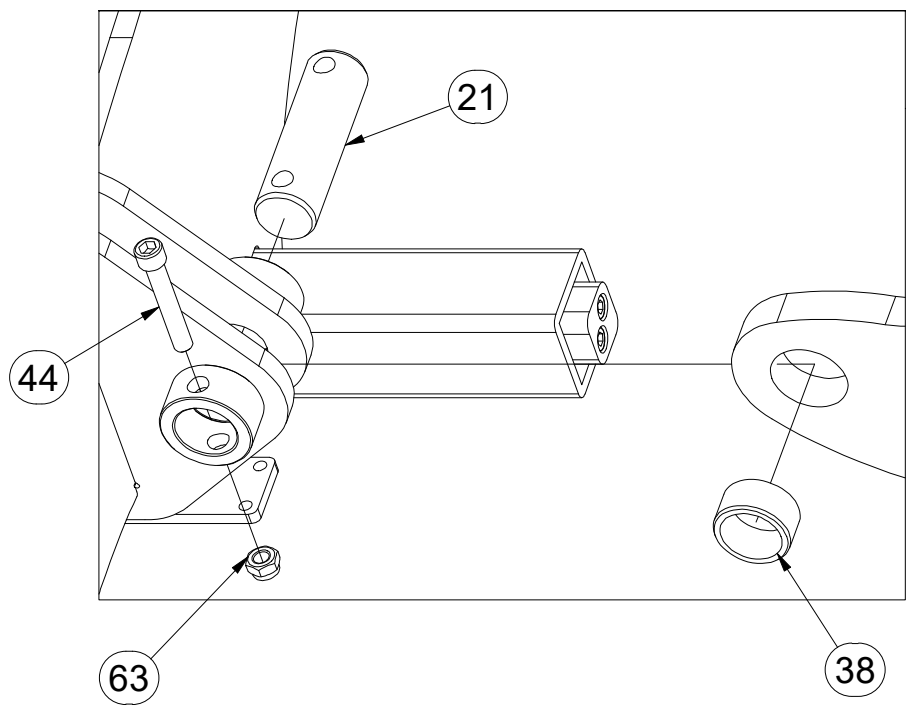
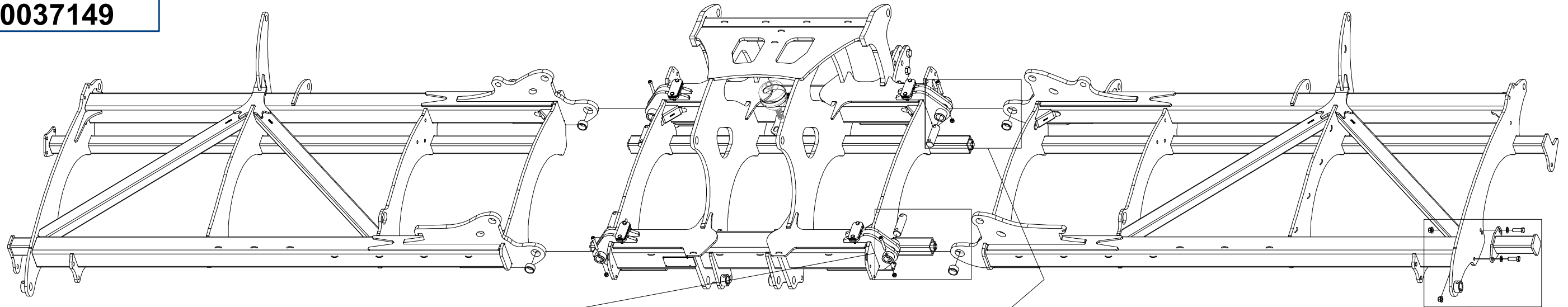

Pos.	Part Number	Pcs.
7	3007071	1
21	4007816	8
38	m15002	4
44	m13033	4
52	m04355	2
63	m04301	36
65	m15730	2
71	m01219	2

☉ ZÁKLAD STROJE

☉ UNTERBAU DER MASCHINE

☉ BÂTI DE LA MACHINE

☉ FOOTING OF THE MACHINE

☉ ОСНОВАНИЕ МАШИНЫ

☉ PODSTAWA MASZINY



VZ00037149

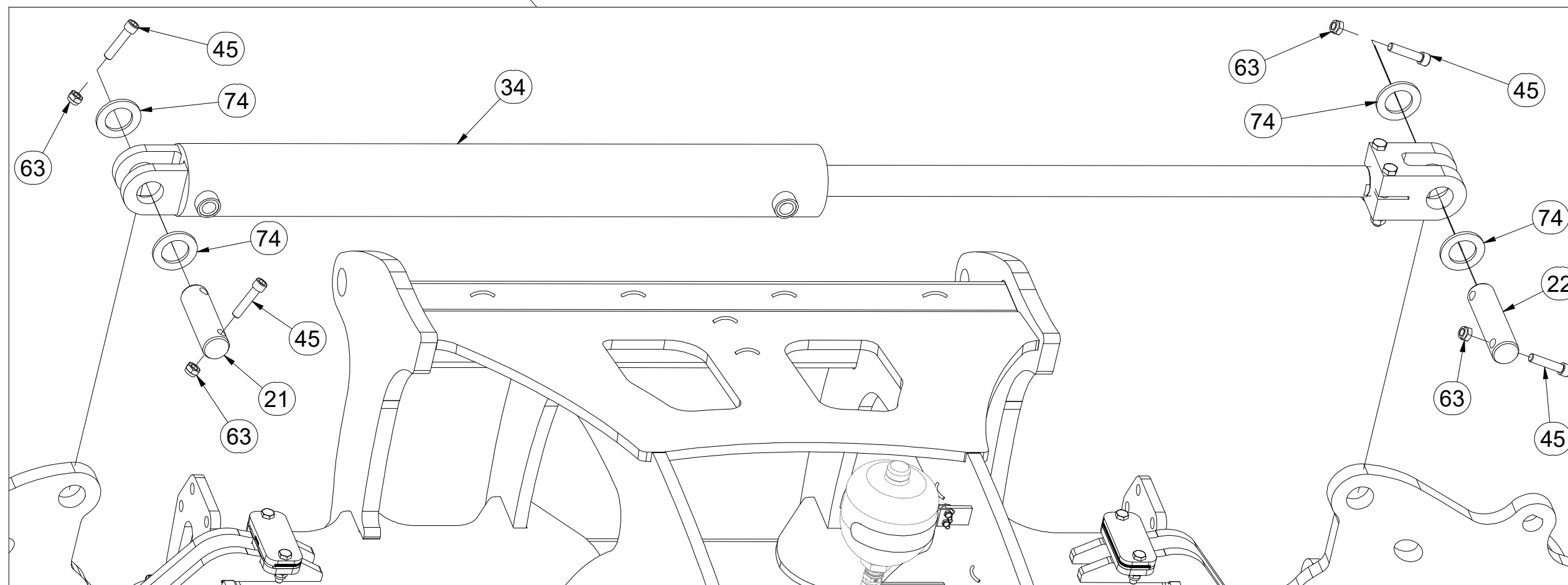
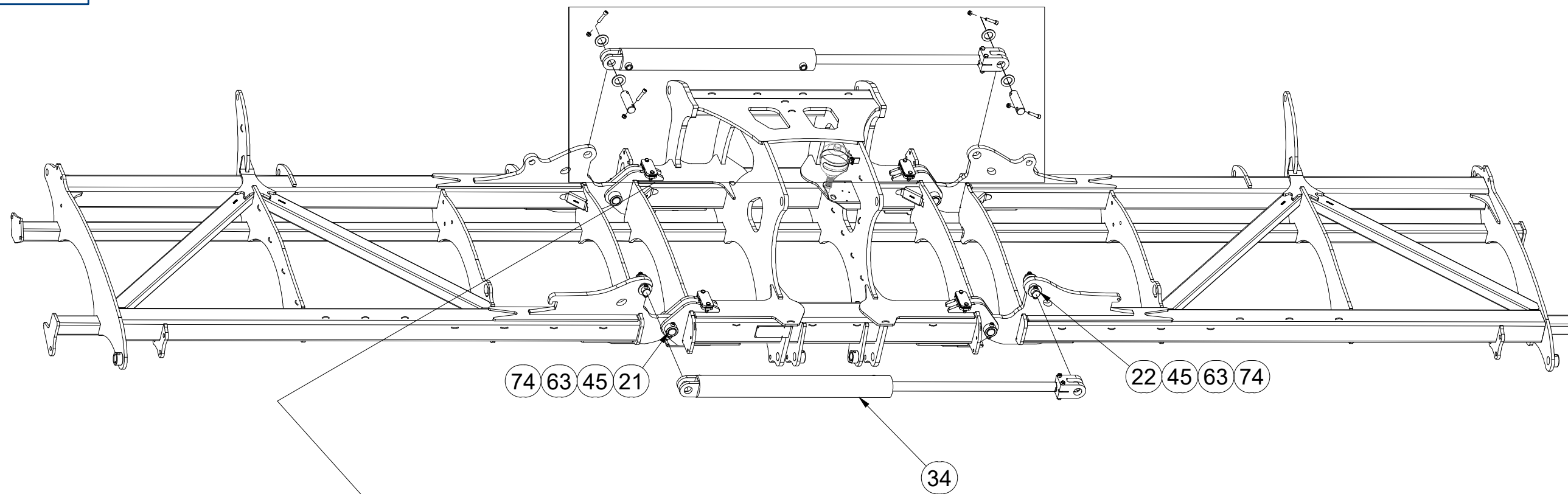

Pos.	Part Number	Pcs.
21	4007816	8
22	4012990	8
34	m21525	2
45	m14008	24
63	m04301	36
74	4013139	24

Ⓒ ZÁKLAD STROJE

Ⓓ UNTERBAU DER MASCHINE

Ⓕ BÂTI DE LA MACHINE

Ⓖ FOOTING OF THE MACHINE

Ⓡ ОСНОВАНИЕ МАШИНЫ

Ⓢ PODSTAWA MASZYNY



VZ00037149

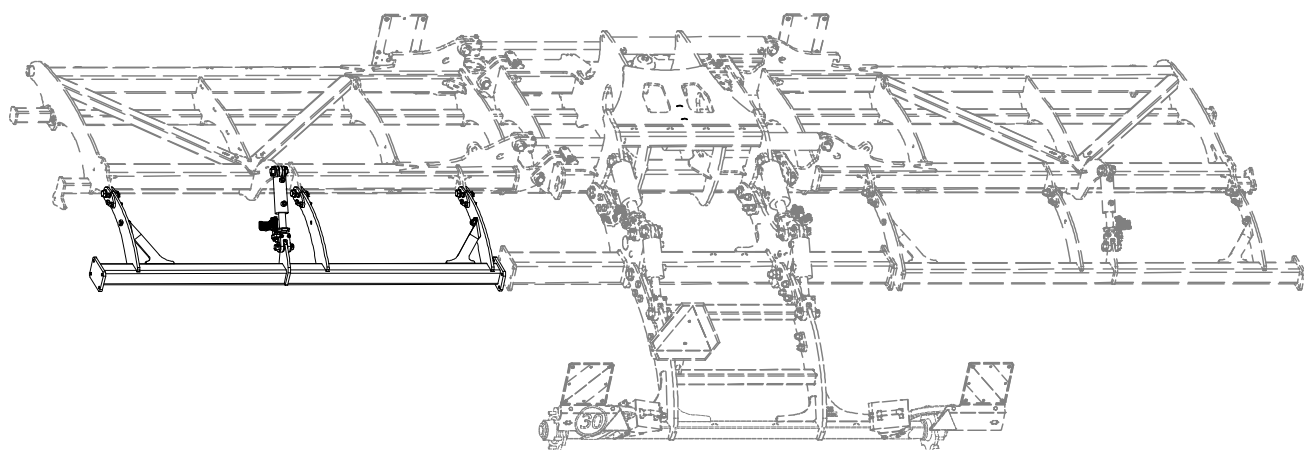
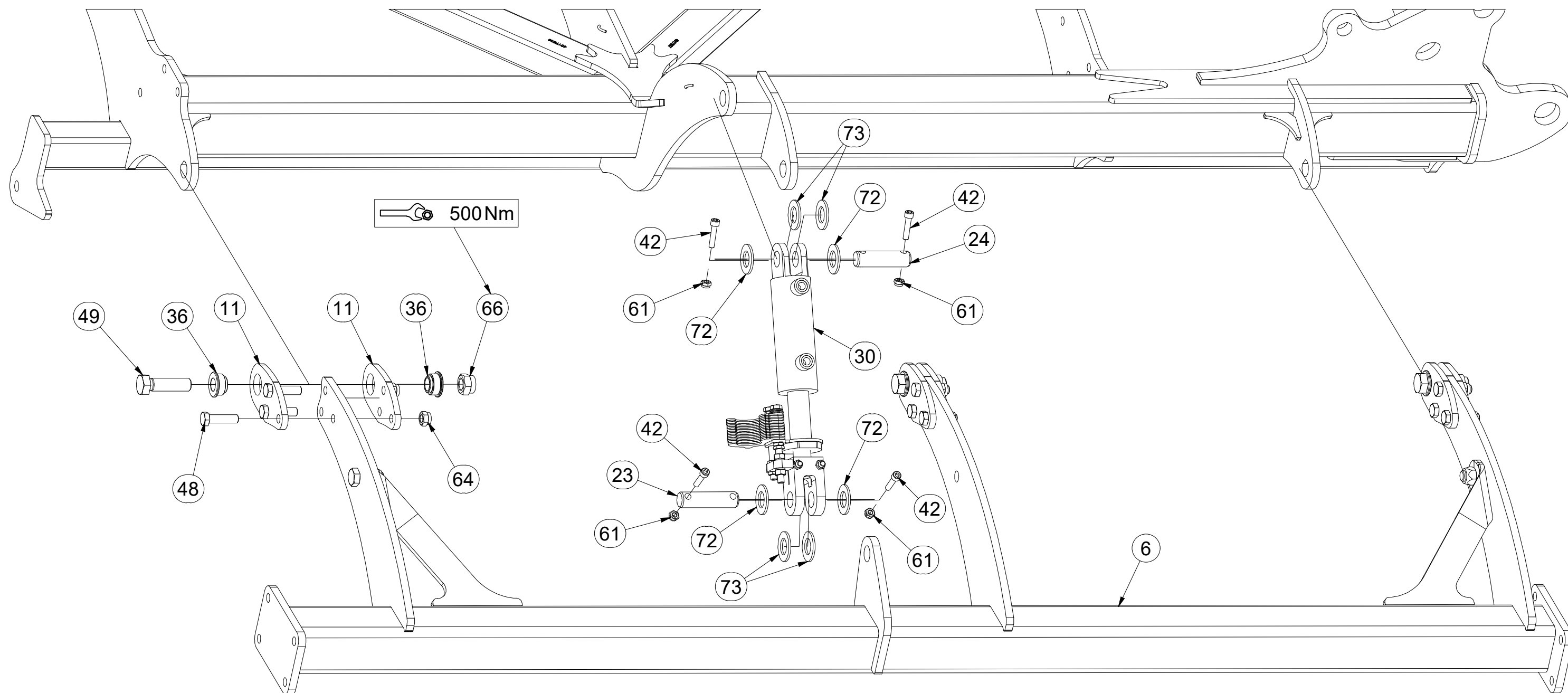

Pos.	Part Number	Pcs.	Pos.	Part Number	Pcs.
6	3008714	1	48	m14482	18
11	4014704	12	49	m08532	6
23	4007639	2	61	m03775	16
24	4007584	2	64	m03683	18
30	VZ00036780	1	66	m07147	12
36	m14506	12	72	m14029	8
42	m14143	8	73	m02866	8

Ⓒ ZÁKLAD STROJE

Ⓓ UNTERBAU DER MASCHINE

Ⓕ BÂTI DE LA MACHINE

Ⓖ FOOTING OF THE MACHINE

Ⓡ ОСНОВАНИЕ МАШИНЫ

Ⓢ PODSTAWA MASZYNY



VZ00037149

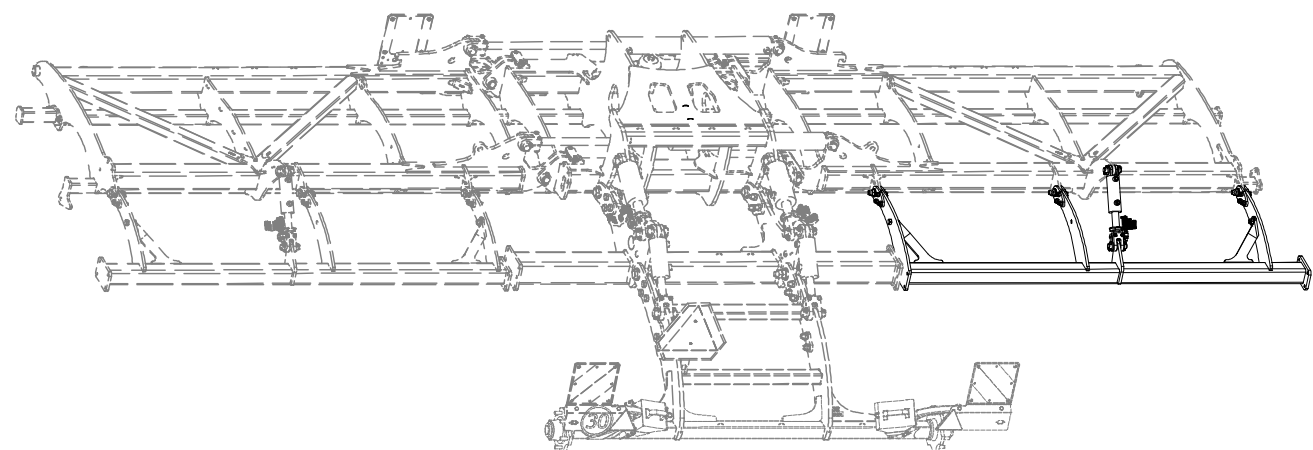
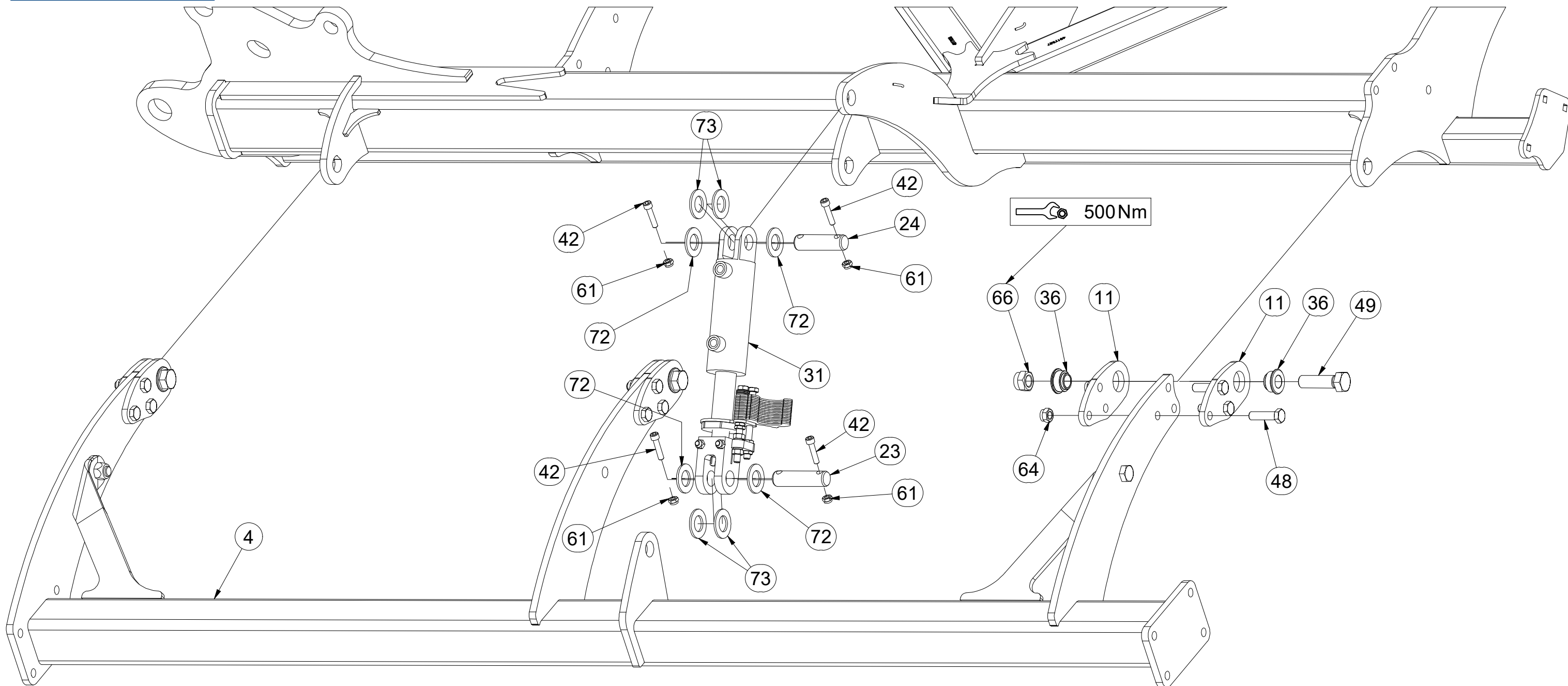

Pos.	Part Number	Pcs.	Pos.	Part Number	Pcs.
4	3008715	1	48	m14482	18
11	4014704	12	49	m08532	6
23	4007639	2	61	m03775	16
24	4007584	2	64	m03683	18
31	VZ00036781	1	66	m07147	12
36	m14506	12	72	m14029	8
42	m14143	8	73	m02866	8

Ⓒ ZÁKLAD STROJE

Ⓓ UNTERBAU DER MASCHINE

Ⓕ BÂTI DE LA MACHINE

Ⓖ FOOTING OF THE MACHINE

Ⓡ ОСНОВАНИЕ МАШИНЫ

Ⓟ PODSTAWA MASZYNY



VZ00037149

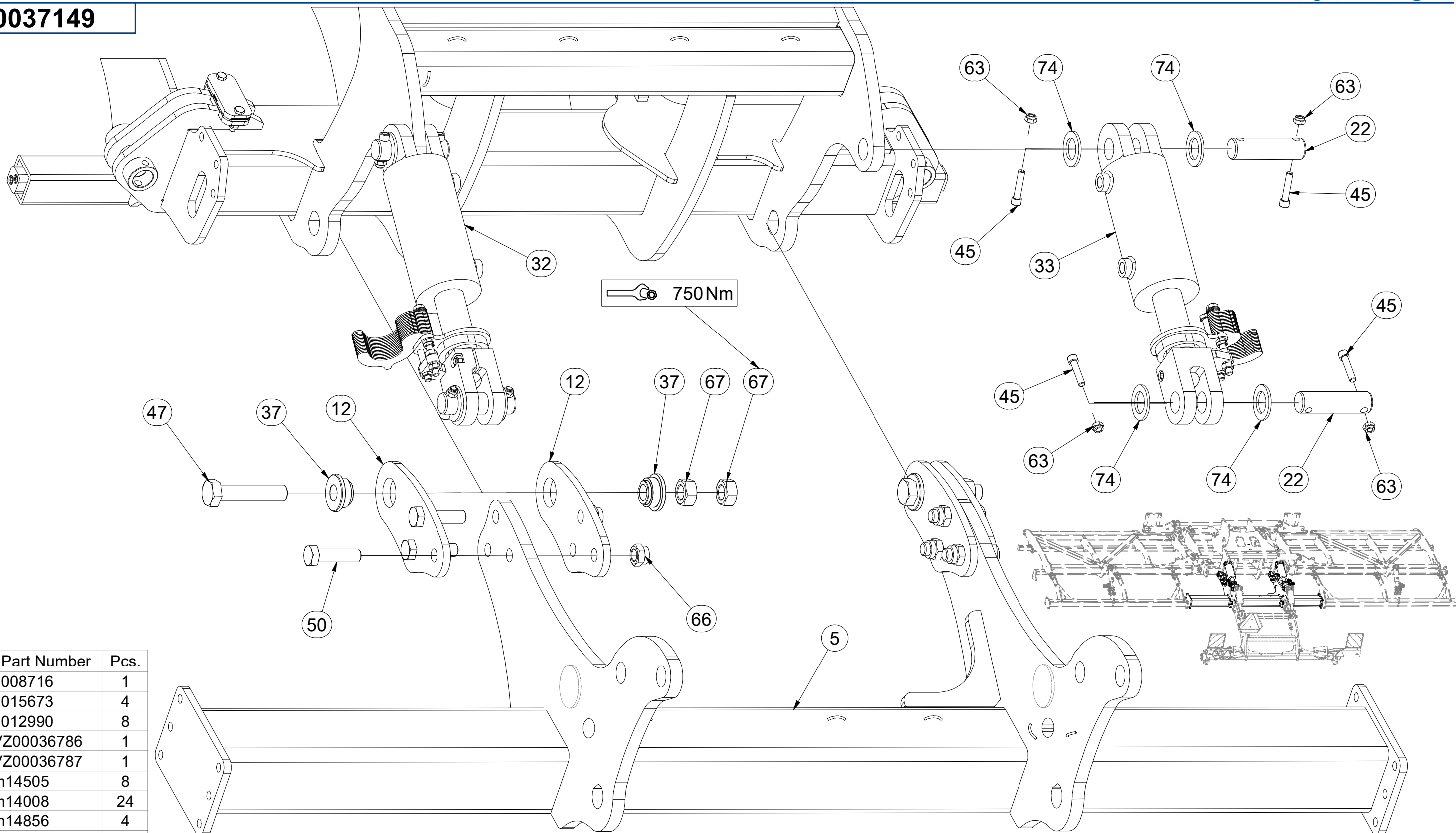

Pos.	Part Number	Pcs.
5	3008716	1
12	4015673	4
22	4012990	8
32	VZ00036786	1
33	VZ00036787	1
37	m14505	8
45	m14008	24
47	m14856	4
50	m14495	6
63	m04301	36
66	m07147	12
67	m01309	8
74	4013139	24

Ⓒ ZÁKLAD STROJE

Ⓓ UNTERBAU DER MASCHINE

Ⓕ BÂTI DE LA MACHINE

Ⓖ FOOTING OF THE MACHINE

Ⓡ ОСНОВАНИЕ МАШИНЫ

Ⓢ PODSTAWA MASZyny



VZ00037149

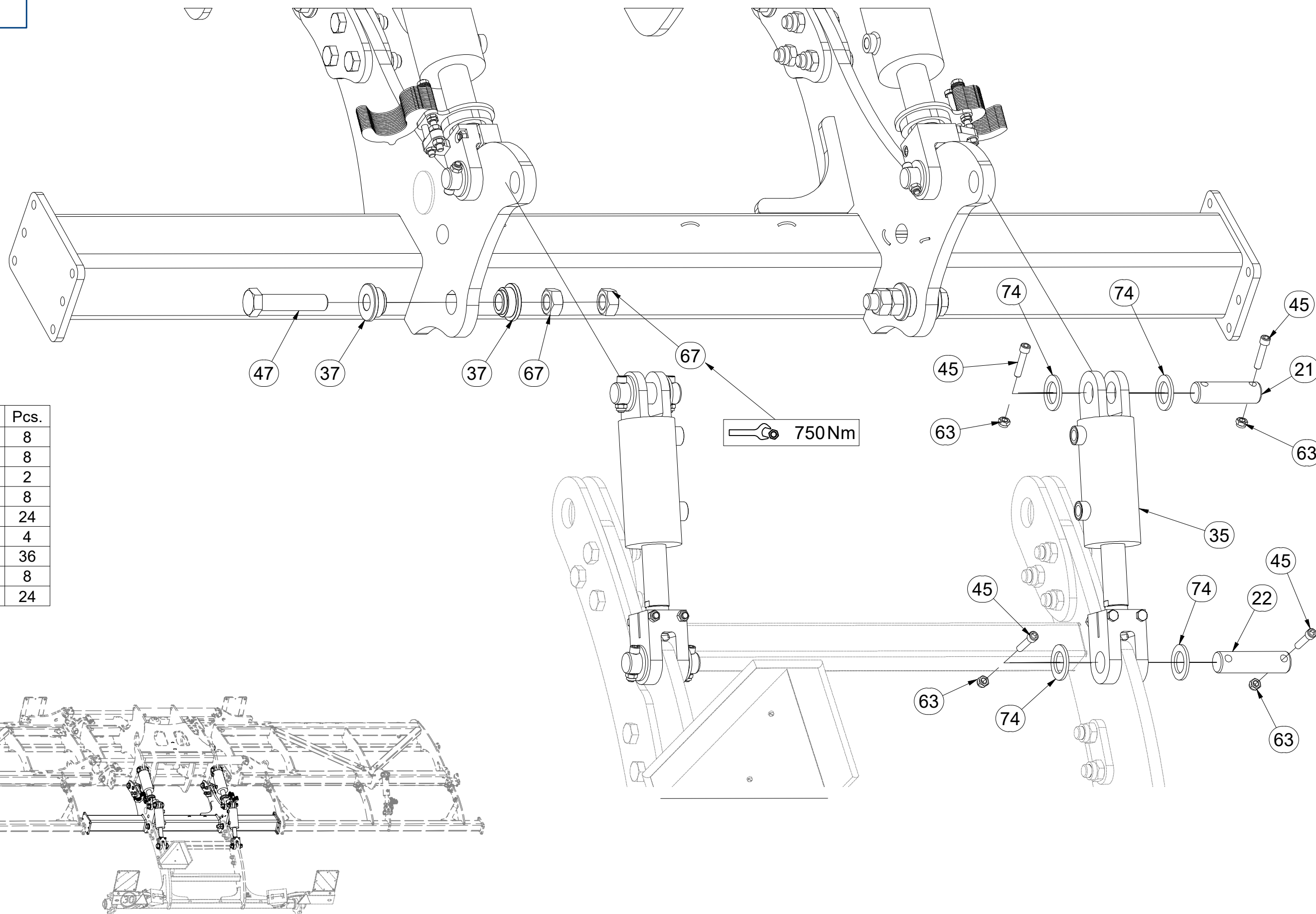

Pos.	Part Number	Pcs.
21	4007816	8
22	4012990	8
35	m17172	2
37	m14505	8
45	m14008	24
47	m14856	4
63	m04301	36
67	m01309	8
74	4013139	24

CZ TERČ PŘEDNÍ
 D SCHILD, VORDERES
 F CIBLE AVANT

GB FRONT DISC
 RU ЩИТОК ПЕРЕДНИЙ
 PL TARCZA PRZEDNIA



4025088

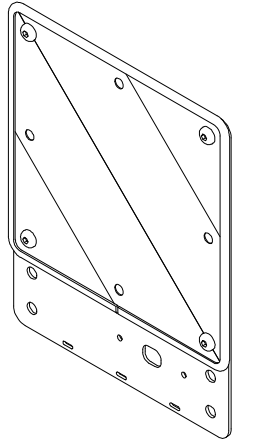
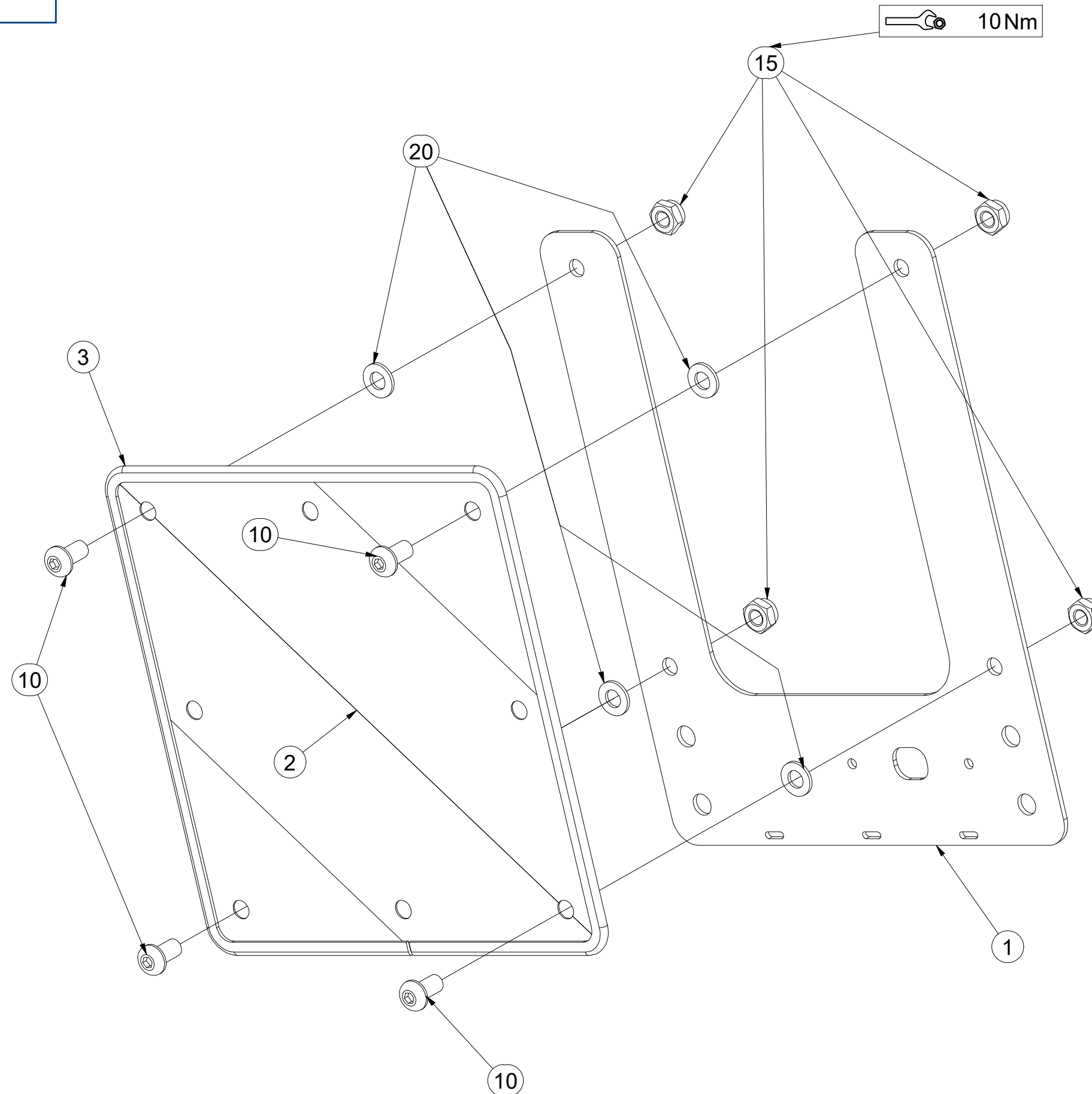

Pos.	Part Number	Pcs.
1	4025090	1
2	m18855	1
3	9005707	1
10	m16637	4
15	m03775	4
20	m01209	4

CZ TERČ PŘEDNÍ
 D SCHILD, VORDERES
 F CIBLE AVANT

GB FRONT DISC
 RU ЩИТОК ПЕРЕДНИЙ
 PL TARCZA PRZEDNIA



4025089

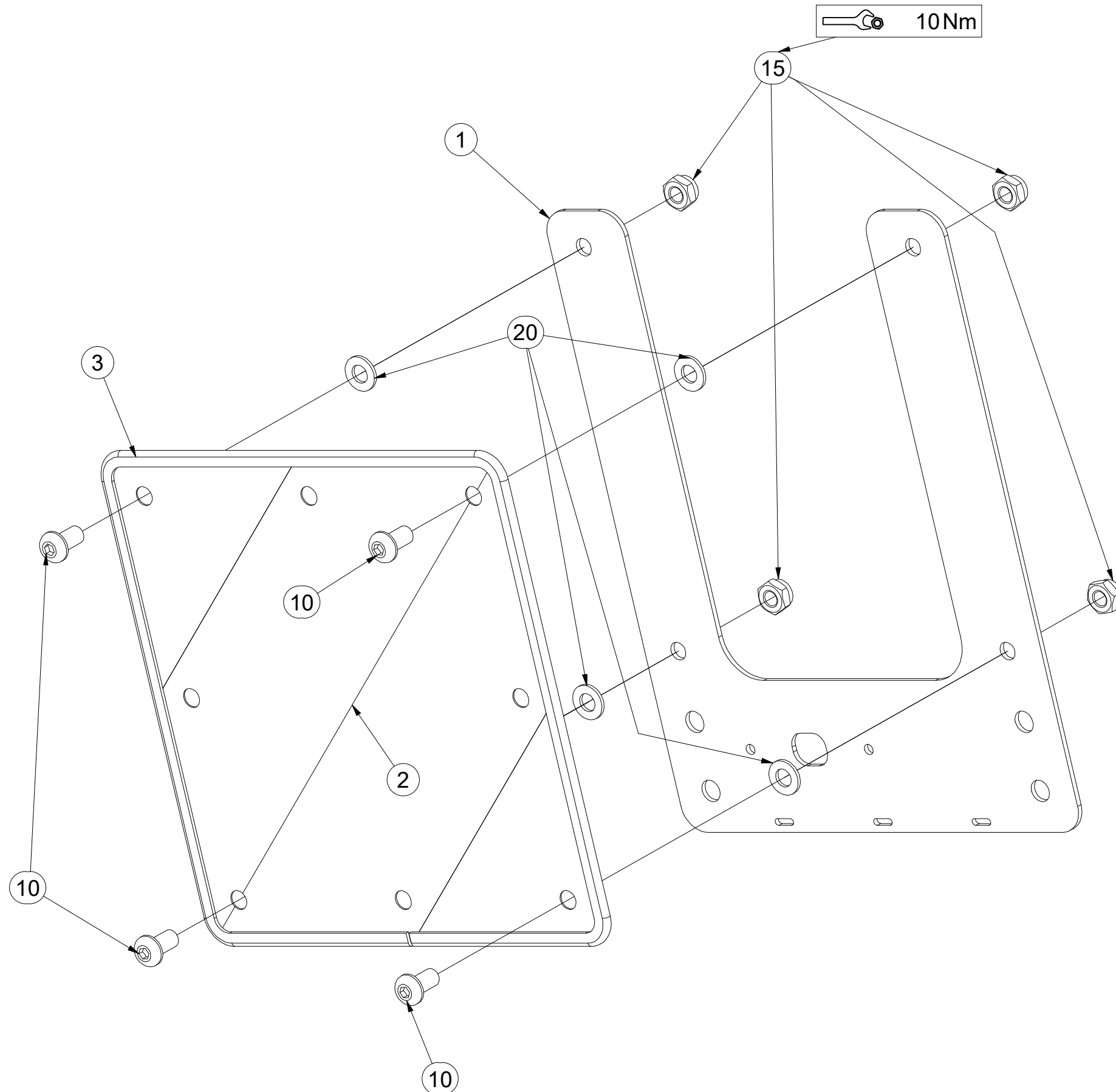

Pos.	Part Number	Pcs.
1	4025090	1
2	m18855	1
3	9005707	1
10	m16637	4
15	m03775	4
20	m01209	4

☉ KOPÍROVACÍ KOLA

☉ KOPIERRÄDER

☉ COPIAGE DU TERRAIN

☉ TRACING WHEELS

☉ КОПИРУЮЩЕЕ КОЛЕСА

☉ KOŁA KOPIUJĄCE



3011554

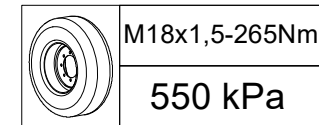

Pos.	Part Number	Pcs.	Pos.	Part Number	Pcs.
1	3011468	1	15	4011764	2
2	3011469	1	19	m21788	2
3	VZ00019975	1	20	m13033	2
4	VZ00019977	1	21	m22861	6
5	4008355	2	22	m05723	6
6	4008058	6	30	m04301	2
7	4008312	1	31	m05648	6
8	4008315	1	32	m20599	6
9	4017145	2	40	m10454	2
10	4015722	4	41	m15782	2
11	4017146	2	42	m12467	2
			45	m04958	2

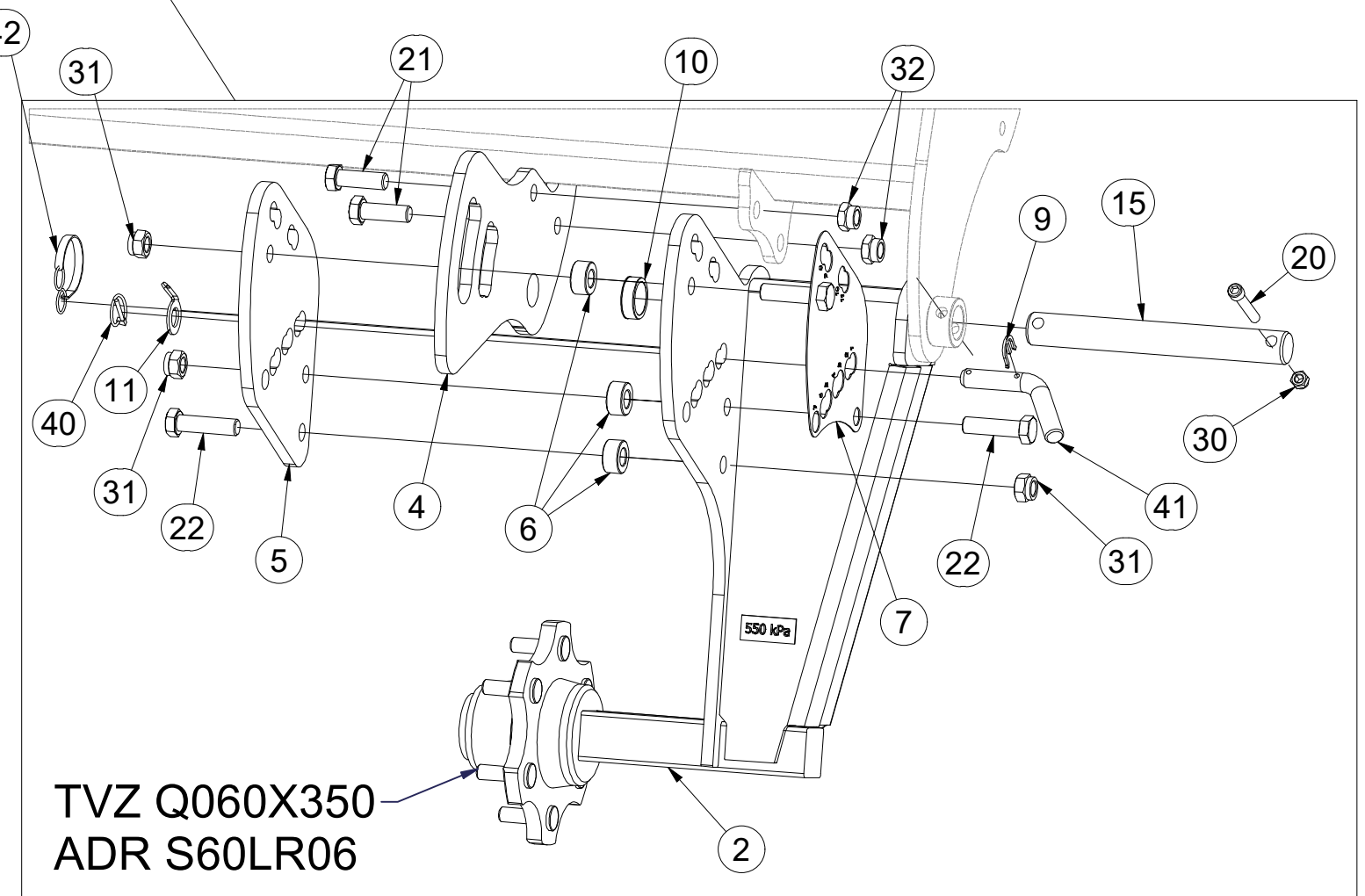
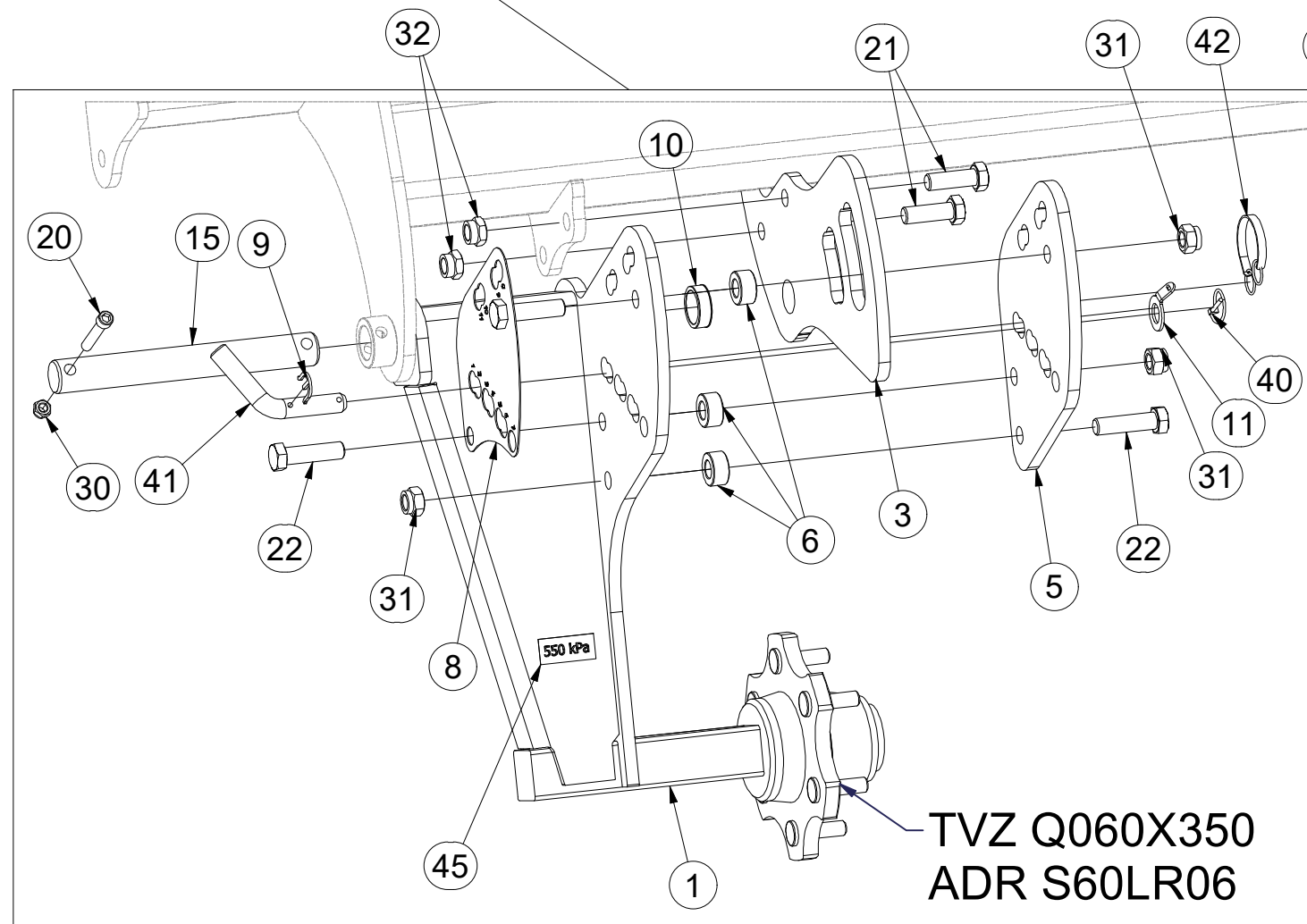
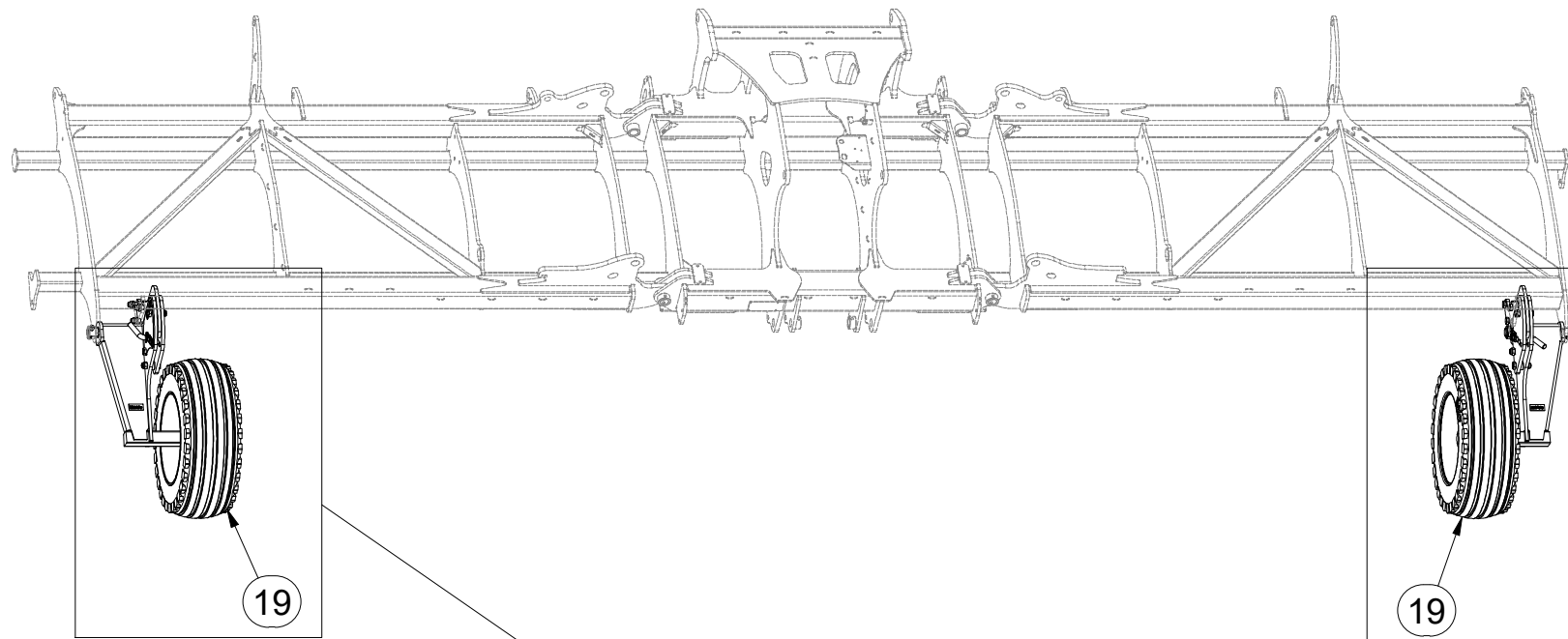

Ⓒ NÁPRAVA

Ⓓ ACHSE

Ⓕ ESSIEU

Q060X350

Ⓖ AXLE

Ⓡ OCB

Ⓟ OS

Farmet

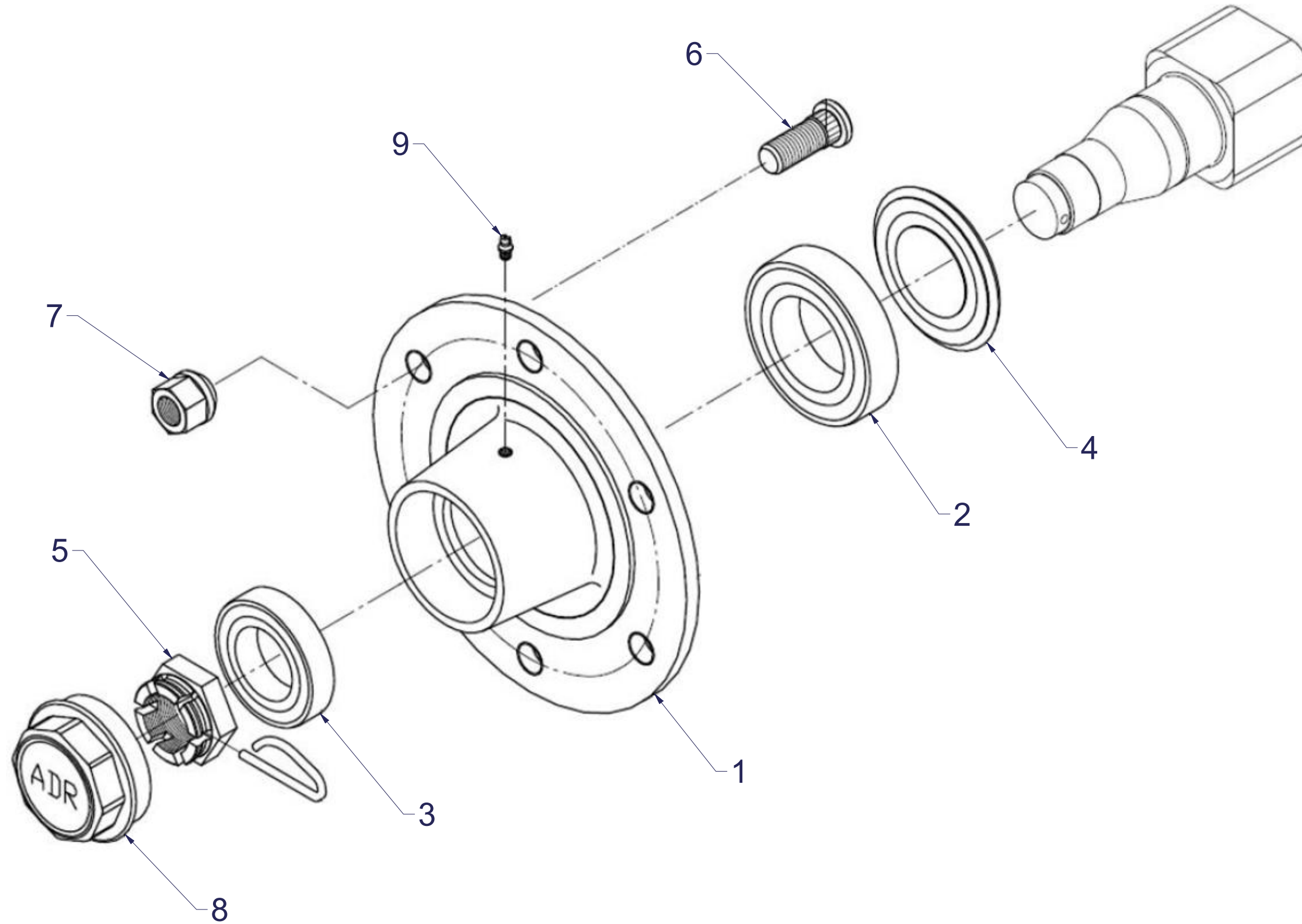

Pos.	Part Number	Pcs.
1	m21713	1
2	m07151	1
3	m07152	1
4	m21717	1
5	m08169	1
6	m08148	6
7	m08163	6
8	m21725	1
9	m05698	1

Ⓒ NÁPRAVA

Ⓓ ACHSE

Ⓕ ESSIEU

Ⓖ AXLE

Ⓡ OCB

Ⓟ OS



S60LR06

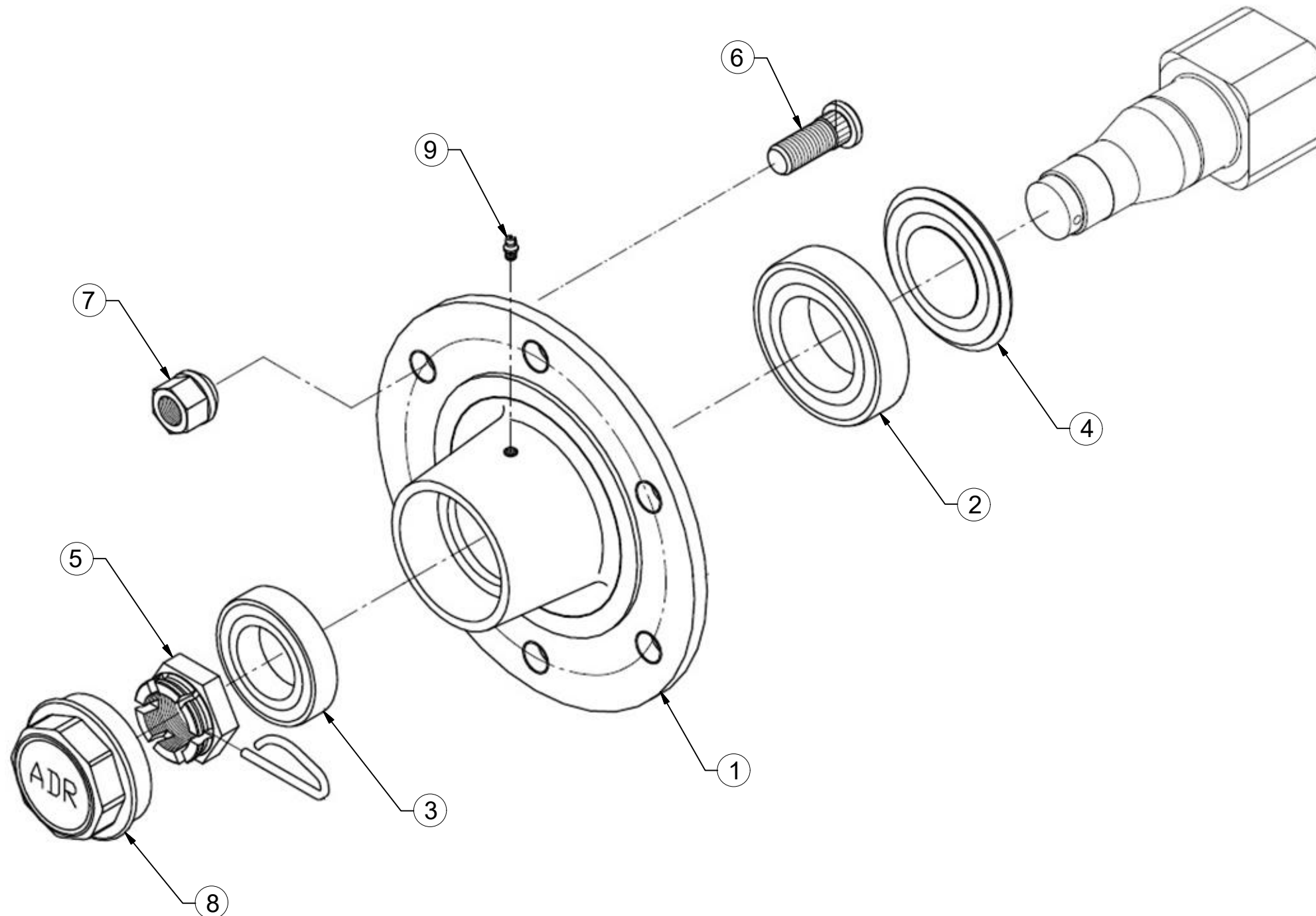

Pos.	Part Number	Pcs.
1	m15631	1
2	m07151	1
3	m07152	1
4	m15058	1
5	m08169	1
6	m08148	6
7	m08163	6
8	m15123	1
9	m05698	1

CZ SADA DISKŮ
 D SCHEIBENSATZ
 F KIT DE DISQUES

GB DISC SET
 RU КОМПЛЕКТ ДИСКОВ
 PL ZESTAW TALERZY



VZ00024356

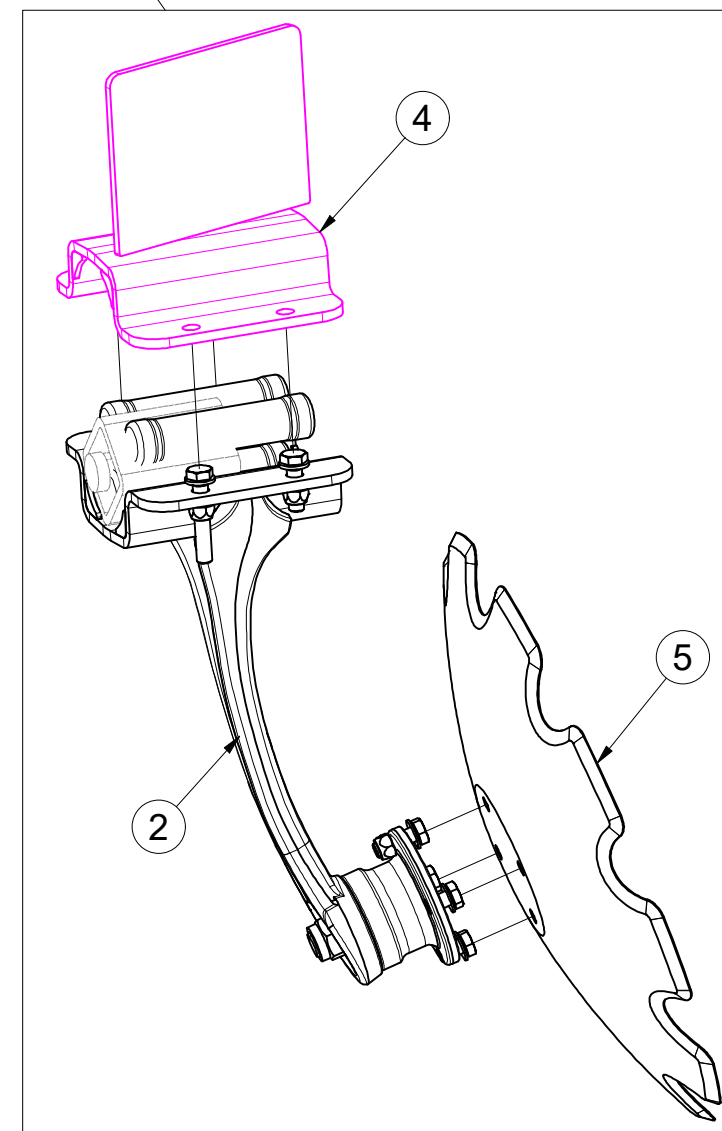
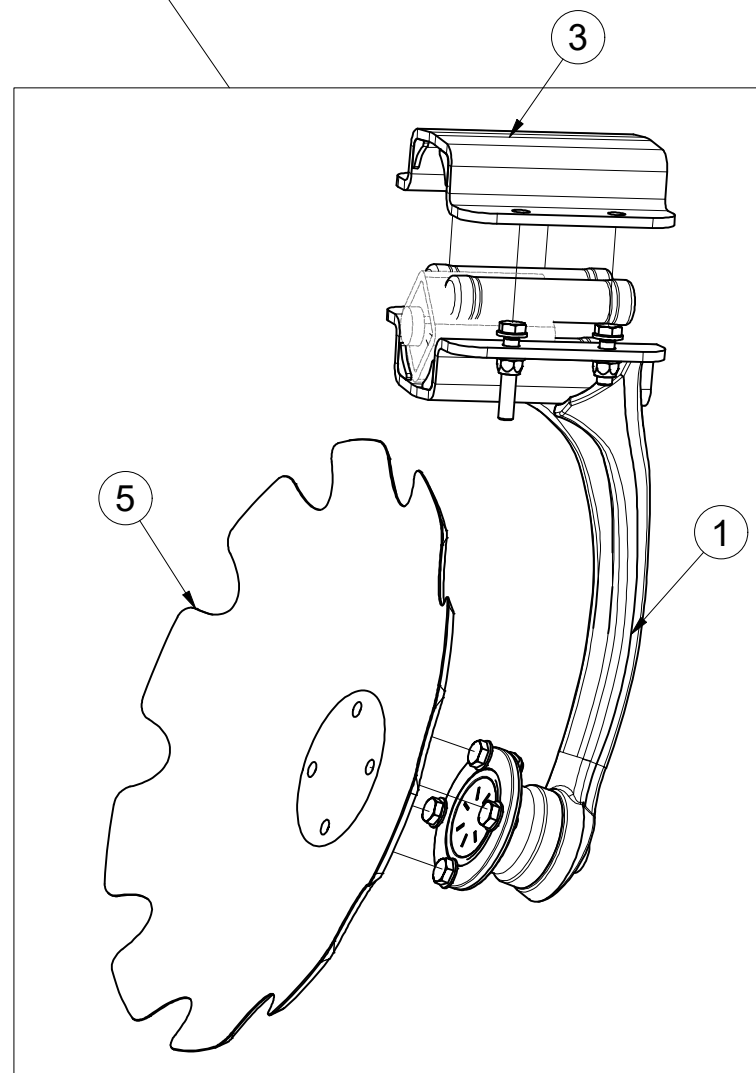
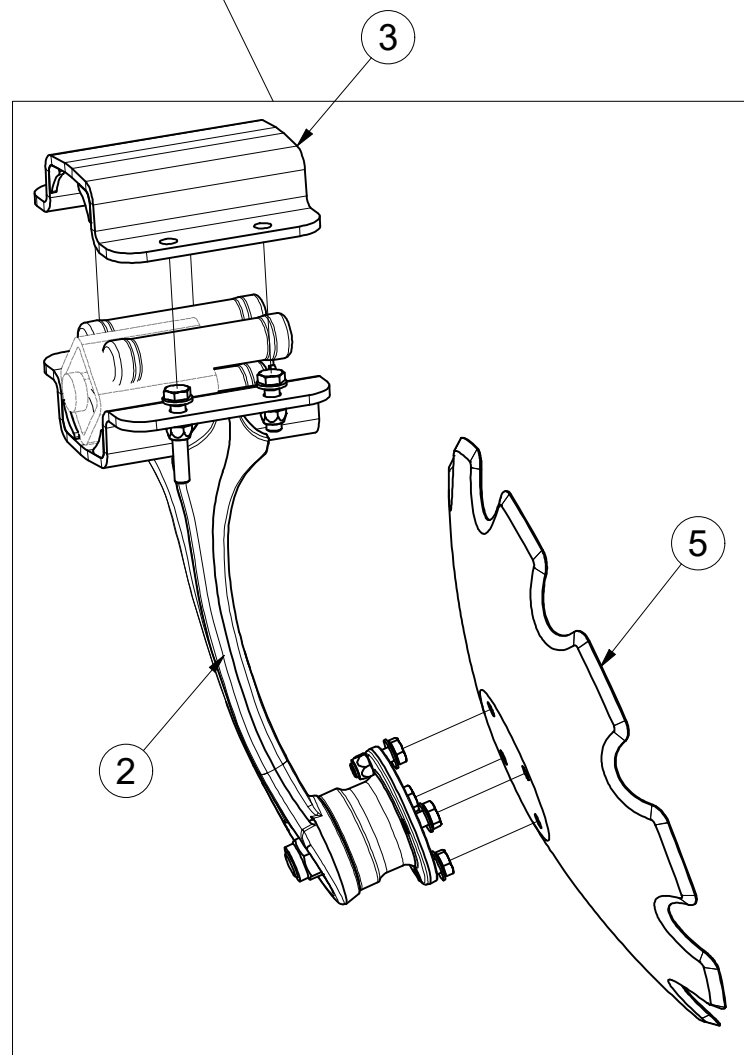
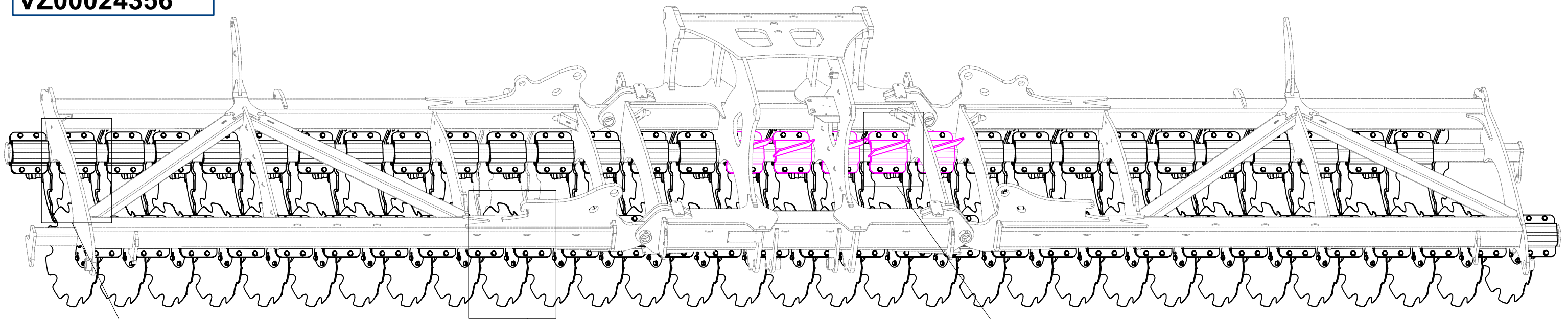

Pos.	Part Number	Pcs.
1	3008374	31
2	3008375	30
3	9004269	56
4	4016392	5
5	3007653	61

CZ PŘEDNÍ DISK
 D SCHEIBE, VORDERE
 F DISQUE AVANT

GB FRONT DISC
 RU ДИСК ПЕРЕДНИЙ
 PL TALERZ PRZEDNI



3008374

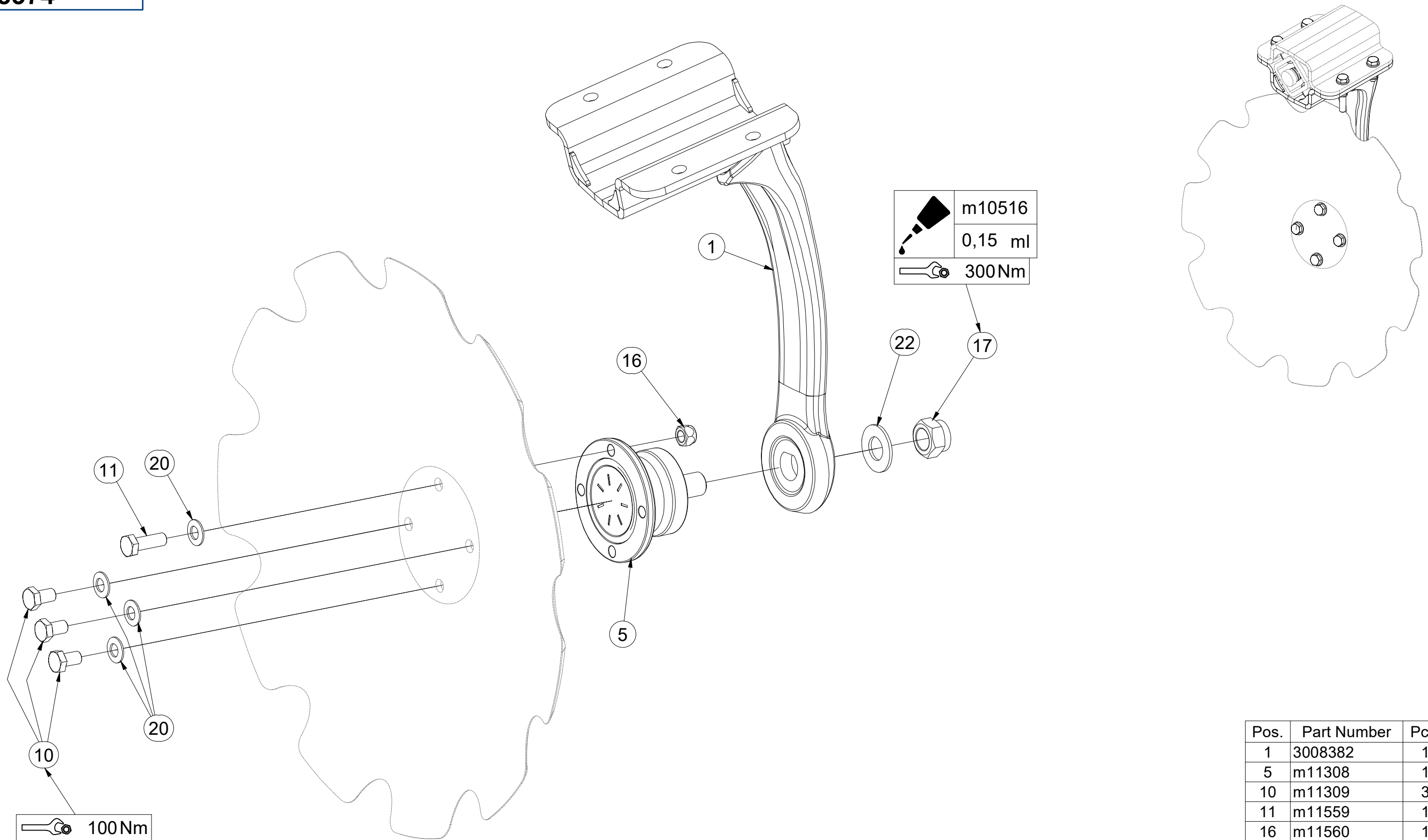

Pos.	Part Number	Pcs.
1	3008382	1
5	m11308	1
10	m11309	3
11	m11559	1
16	m11560	1
17	m11313	1
20	m17545	4
22	VZ00011395	1

(CZ) PŘEDNÍ DISK
 (D) SCHEIBE, VORDERE
 (F) DISQUE AVANT

(GB) FRONT DISC
 (RU) ДИСК ПЕРЕДНИЙ
 (PL) TALERZ PRZEDNI



3008374

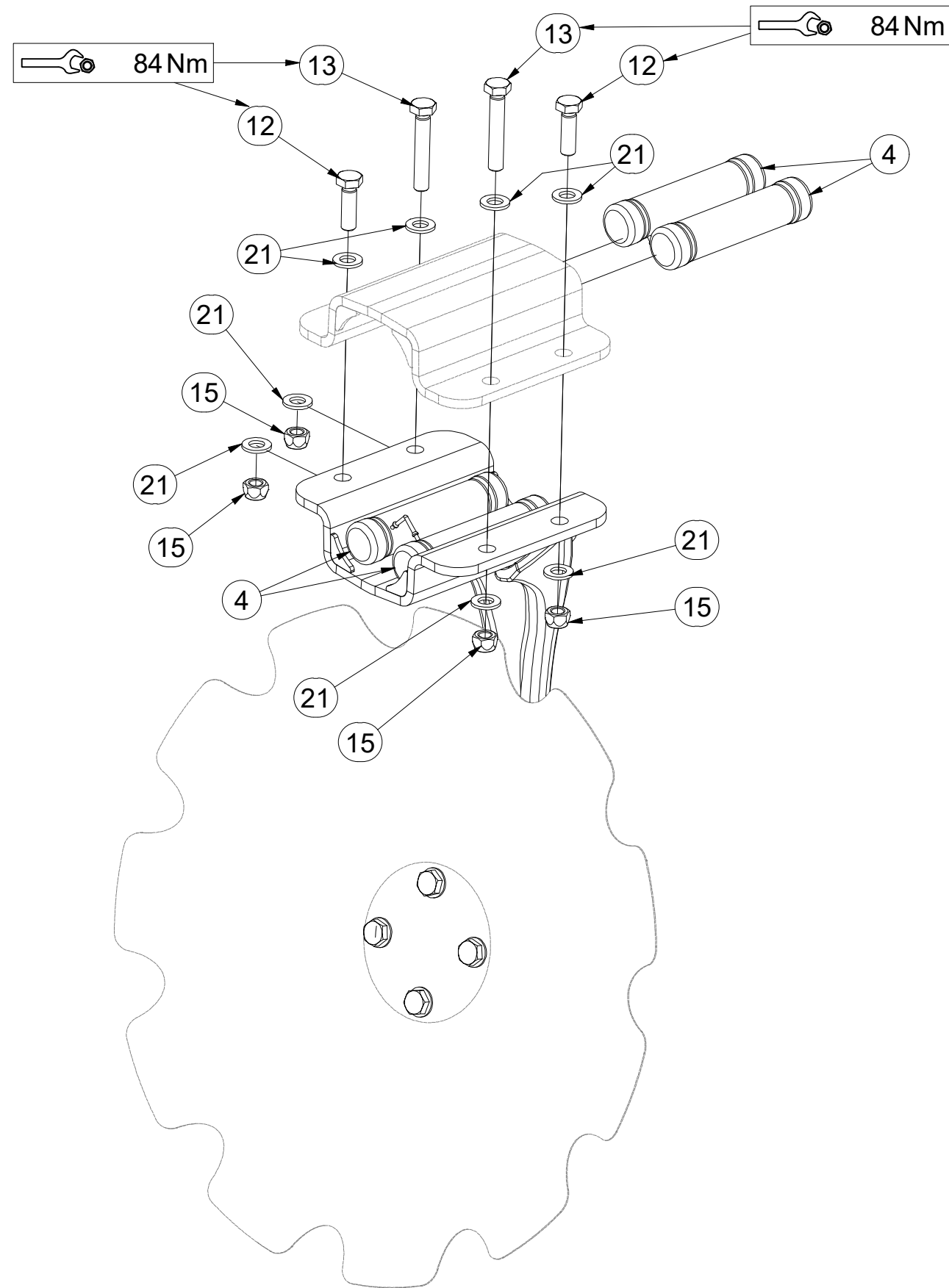

Pos.	Part Number	Pcs.
4	VZ00003901	4
12	m17657	2
13	m17653	2
15	m12134	4
21	m17741	8

CZ ZADNÍ DISK
 D SCHEIBE, HINTERE
 F DISQUE ARRIÈRE

GB REAR DISC
 RU ДИСК ЗАДНИЙ
 PL TALERZ TYLNY



3008375

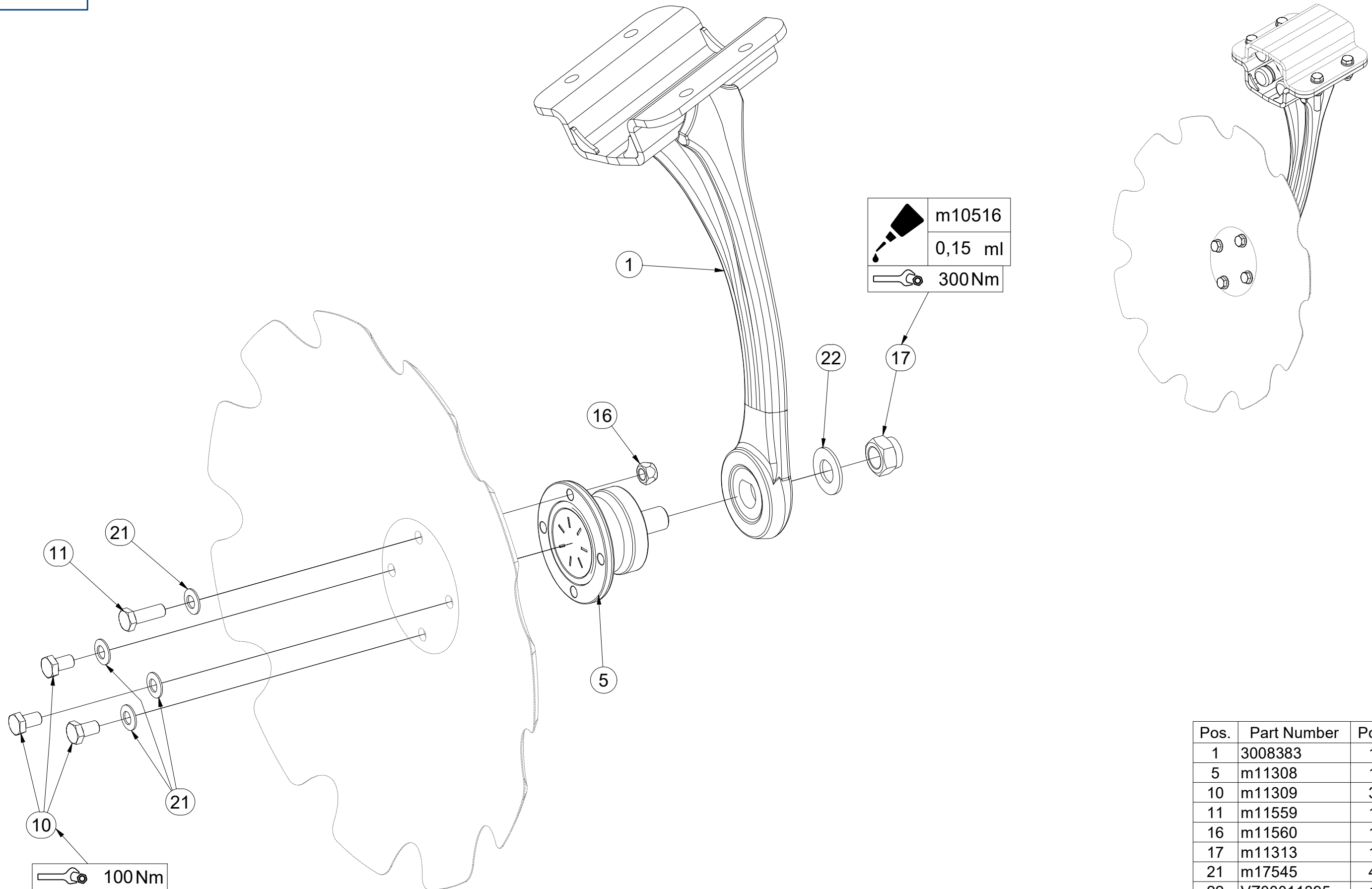

Pos.	Part Number	Pcs.
1	3008383	1
5	m11308	1
10	m11309	3
11	m11559	1
16	m11560	1
17	m11313	1
21	m17545	4
22	VZ00011395	1

CZ ZADNÍ DISK
 D SCHEIBE, HINTERE
 F DISQUE ARRIÈRE

GB REAR DISC
 RU ДИСК ЗАДНИЙ
 PL TALERZ TYLNY



3008375

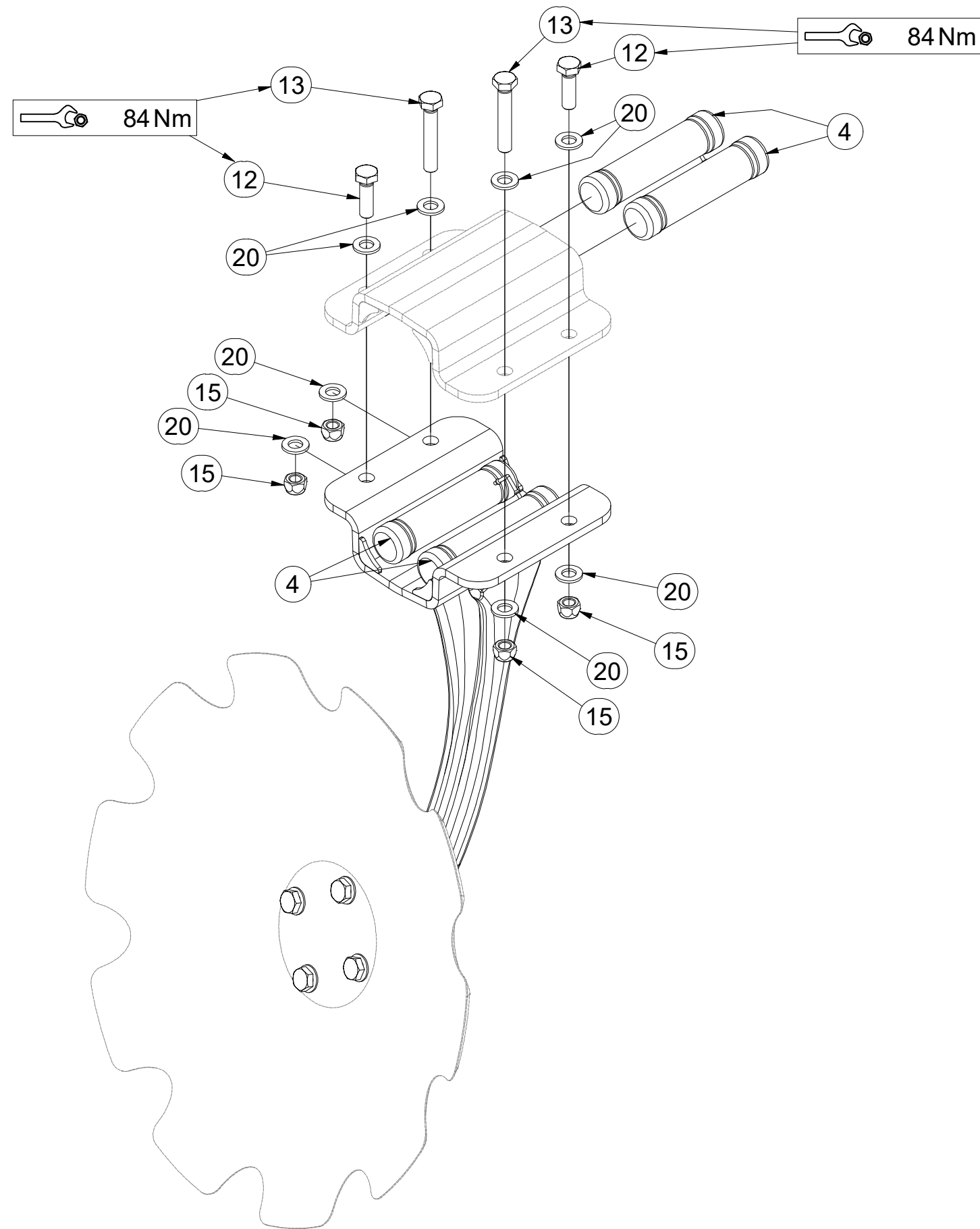

Pos.	Part Number	Pcs.
4	VZ00003901	4
12	m17657	2
13	m17653	2
15	m12134	4
20	m17741	8

CZ DEFLEKTOR LEVÝ
 D DEFLEKTOR, LINKER
 F DÉFLECTEUR GAUCHE

GB DEFLECTOR LEFT
 RU ДЕФЛЕКТОР ЛЕВЫЙ
 PL DEFLEKTOR LEWY



3004585

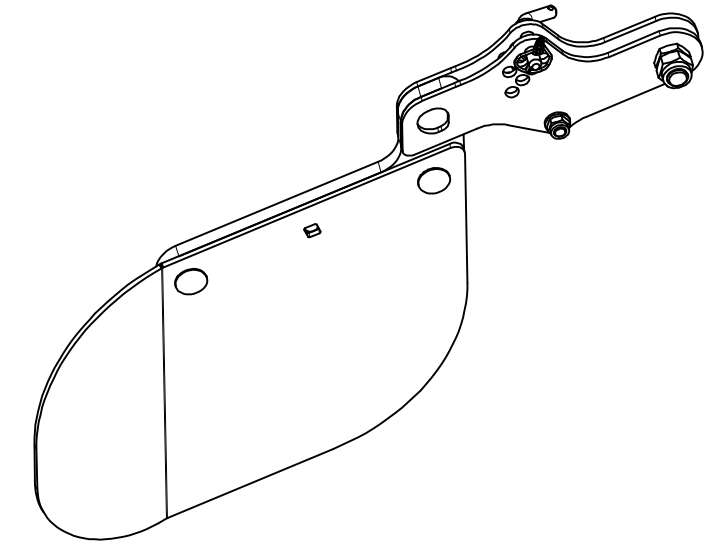
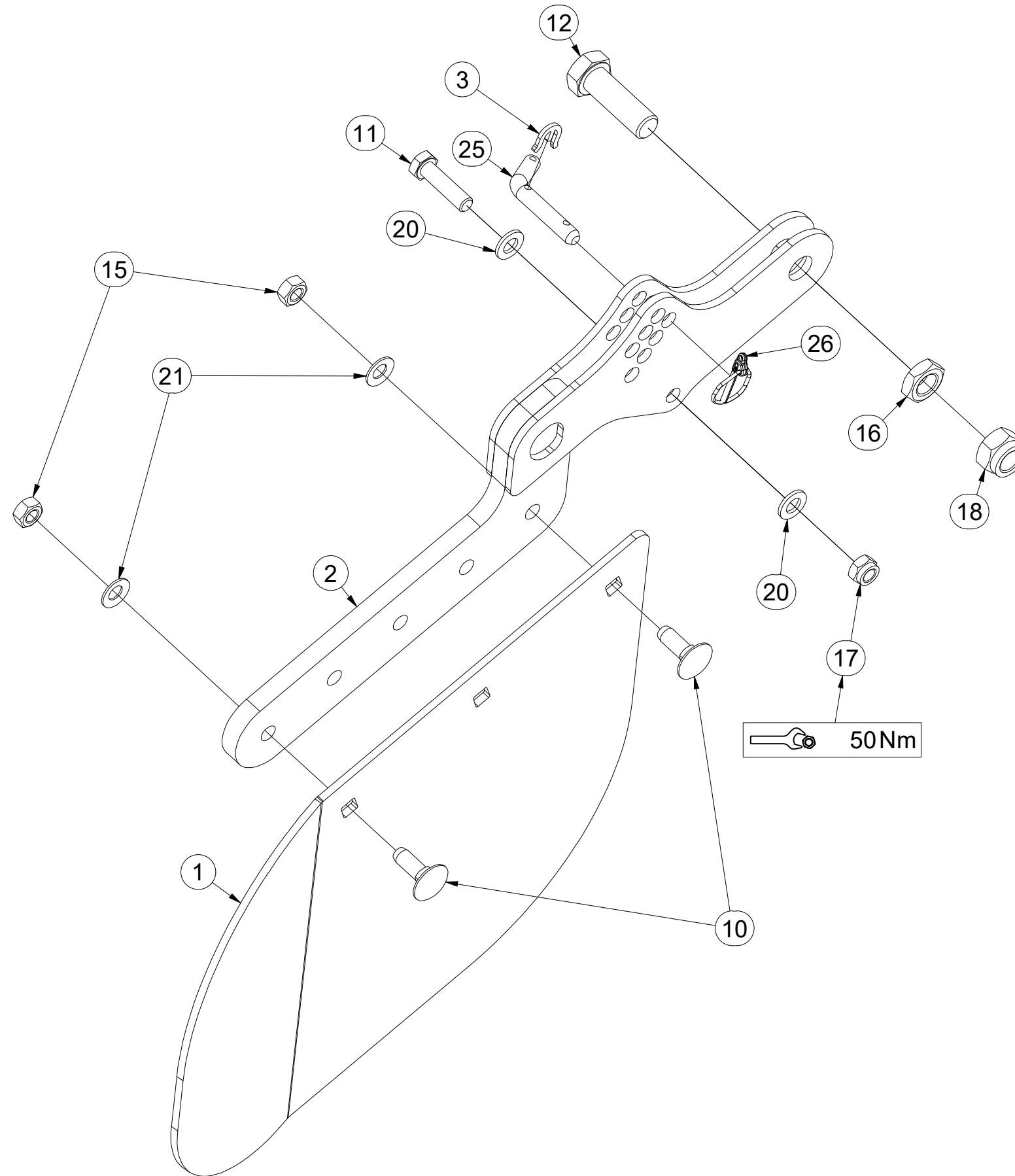

Pos.	Part Number	Pcs.	Pos.	Part Number	Pcs.
1	4007854	1	16	m04284	1
2	4008743	1	17	m04301	1
3	4016279	1	18	m05648	1
10	m10618	2	20	m01214	2
11	m06077	1	21	m17545	2
12	m05747	1	25	m09141	1
15	m10439	2	26	m10454	1

Ⓒ DEFLEKTOR PRAVÝ
Ⓓ DEFLEKTOR, RECHTER
Ⓕ DÉFLECTEUR DROIT

VZ00036778

Ⓖ DEFLECTOR RIGHT
Ⓔ ДЕФЛЕКТОР ПРАВЫЙ
Ⓗ DEFLEKTOR PRAWY

Farmet

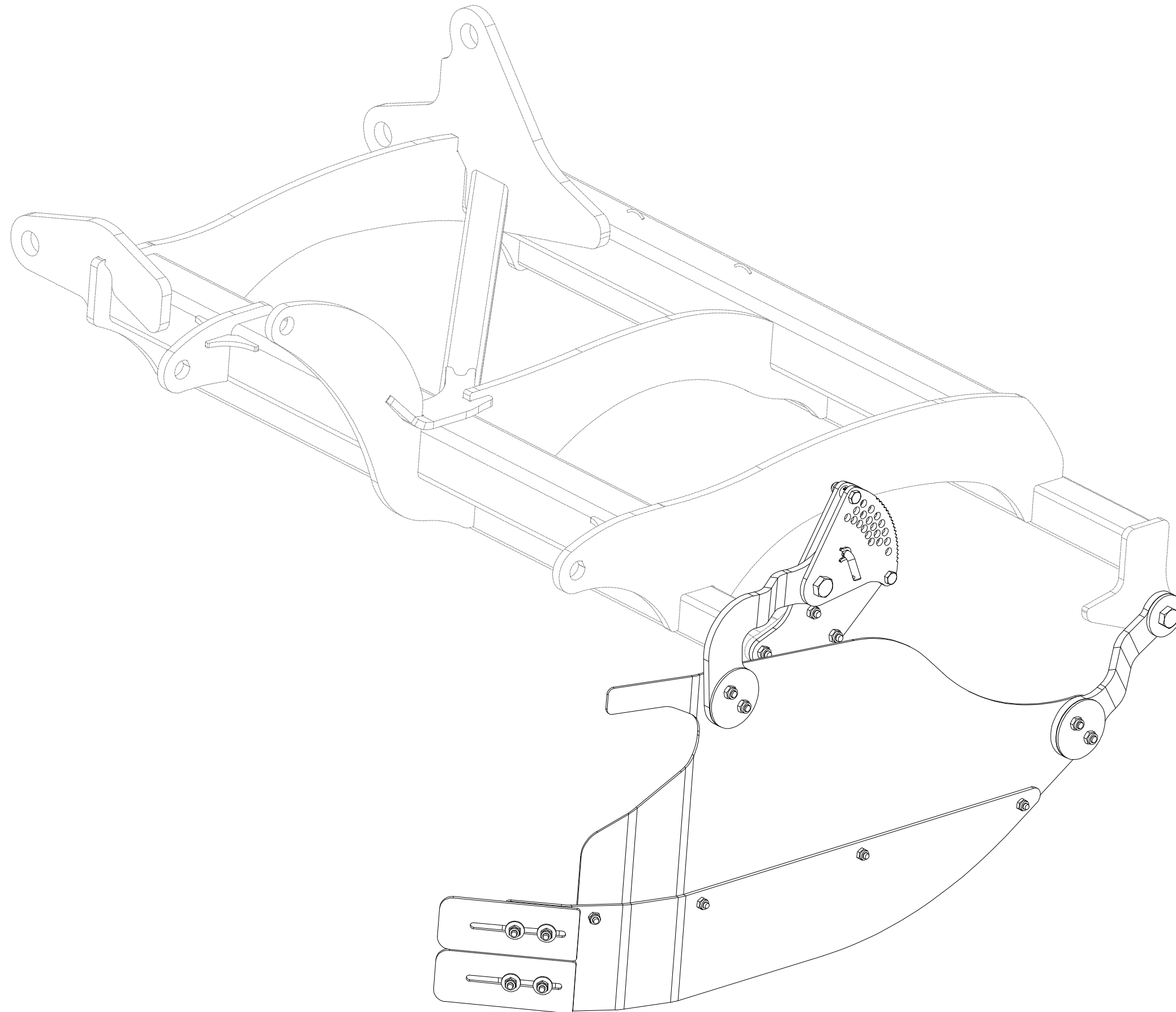

CZ DEFLEKTOR PRAVÝ
 D DEFLEKTOR, RECHTER
 F DÉFLECTEUR DROIT

GB DEFLECTOR RIGHT
 RU ДЕФЛЕКТОР ПРАВЫЙ
 PL DEFLEKTOR PRAWY



VZ00036778

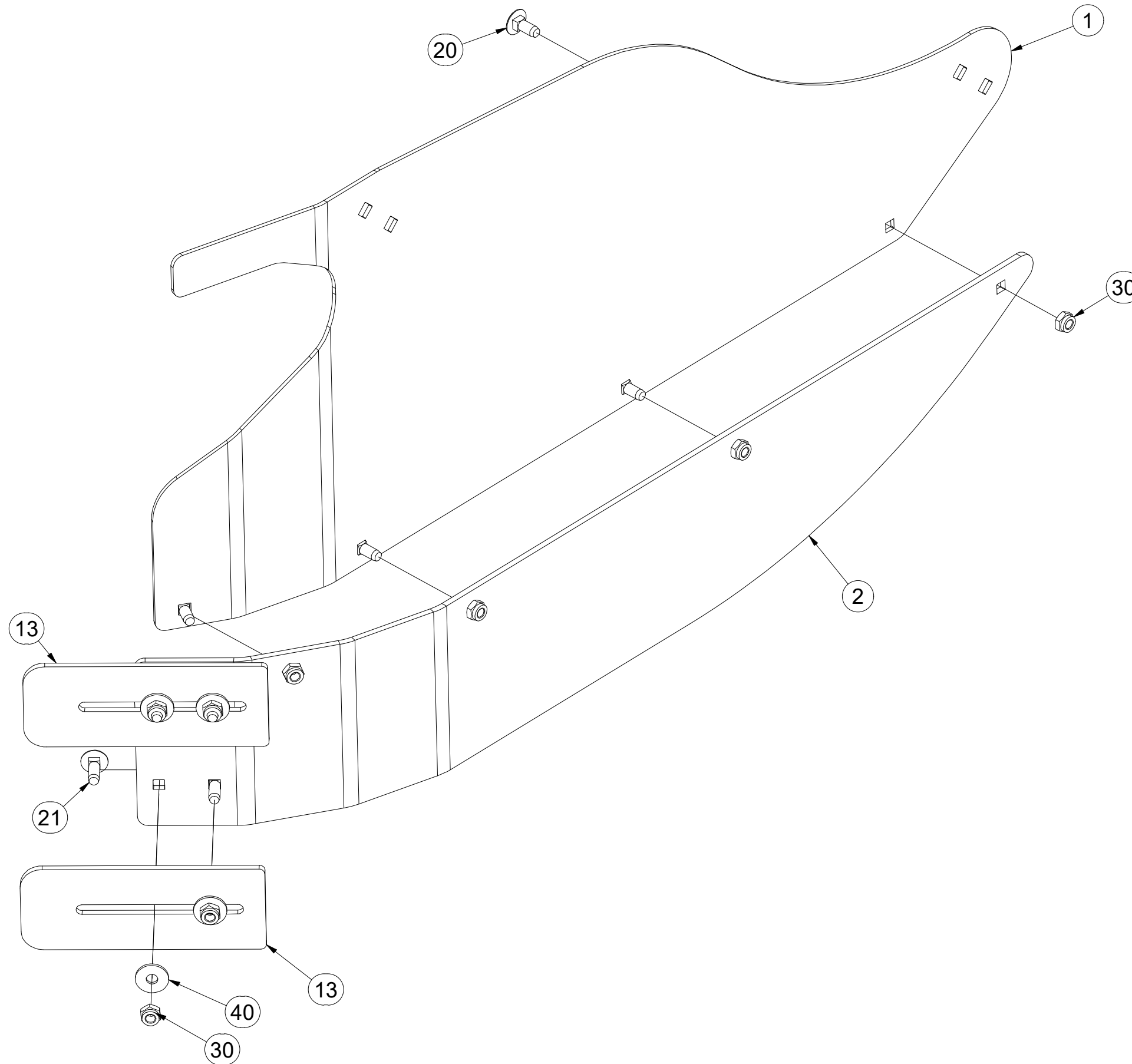

Pos.	Part Number	Pcs.
1	VZ00023005	1
2	VZ00022377	1
13	VZ00022131	2
20	m03129	4
21	m19153	4
30	m03775	8
40	m16981	4

CZ DEFLEKTOR PRAVÝ
 D DEFLEKTOR, RECHTER
 F DÉFLECTEUR DROIT

GB DEFLECTOR RIGHT
 RU ДЕФЛЕКТОР ПРАВЫЙ
 PL DEFLEKTOR PRAWY



VZ00036778

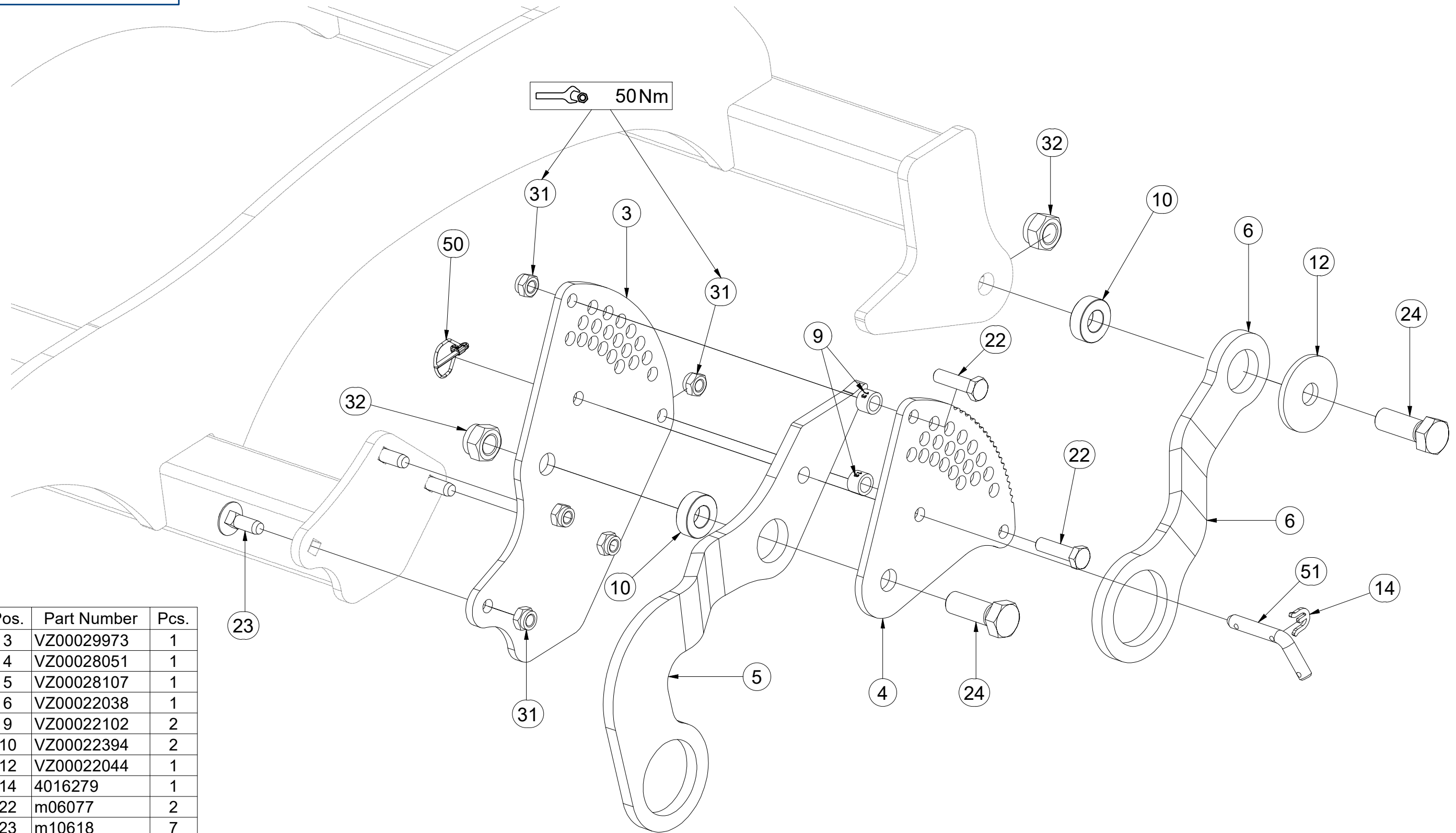

Pos.	Part Number	Pcs.
3	VZ00029973	1
4	VZ00028051	1
5	VZ00028107	1
6	VZ00022038	1
9	VZ00022102	2
10	VZ00022394	2
12	VZ00022044	1
14	4016279	1
22	m06077	2
23	m10618	7
24	m12771	2
31	m04301	9
32	m05648	2
50	m10454	1
51	m09141	1

CZ DEFLEKTOR PRAVÝ
 D DEFLEKTOR, RECHTER
 F DÉFLECTEUR DROIT

GB DEFLECTOR RIGHT
 RU ДЕФЛЕКТОР ПРАВЫЙ
 PL DEFLEKTOR PRAWY



VZ00036778

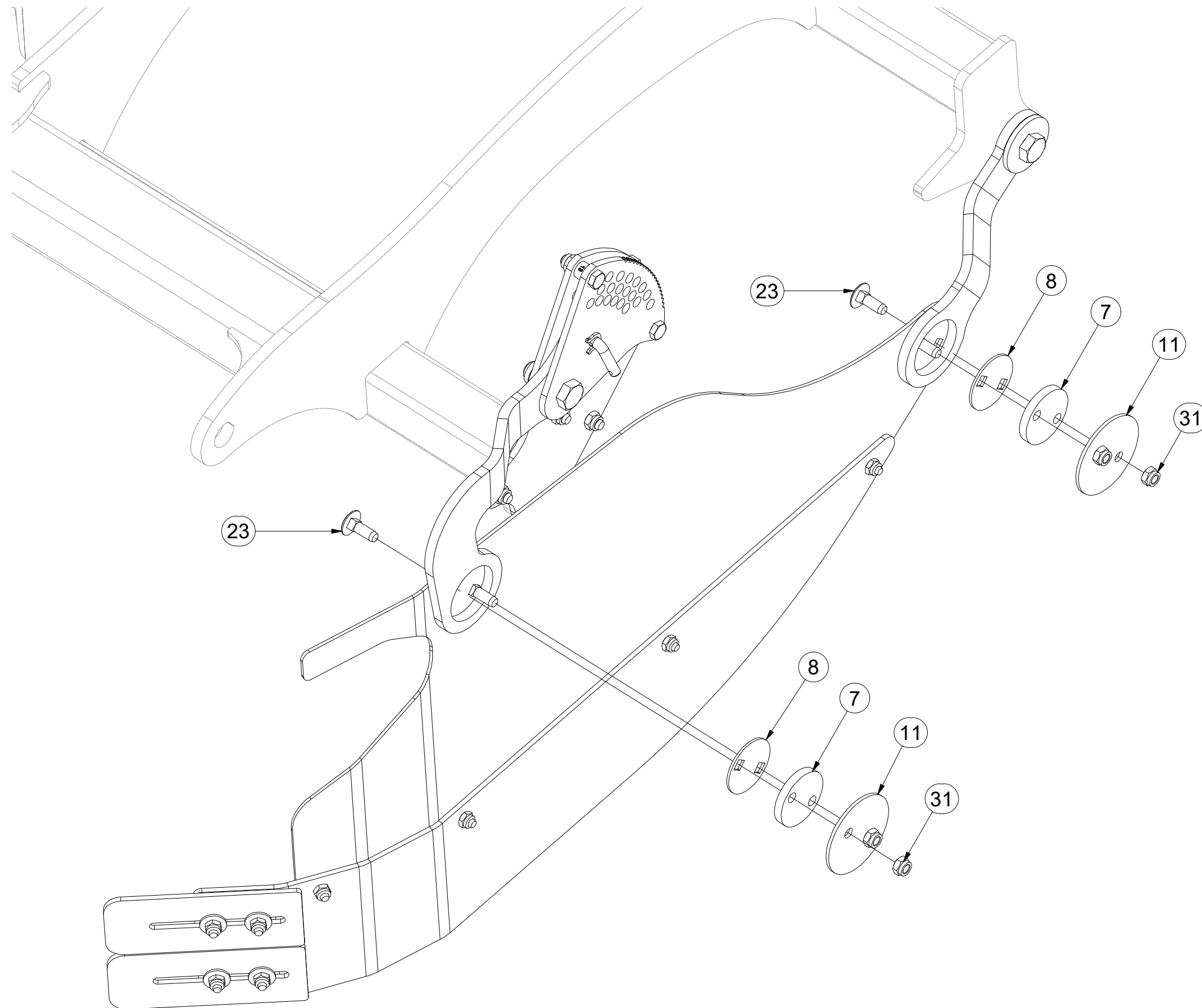

Pos.	Part Number	Pcs.
7	VZ00022395	2
8	VZ00022432	2
11	VZ00022433	2
23	m10618	7
31	m04301	9

Ⓒ SADA ZADNÍCH VÁLCŮ

Ⓓ SATZ HINTERE WALZEN

Ⓕ KIT DE ROULEAUX ARRIÈRE

VZ00038581

Ⓒ SET OF REAR ROLLERS

Ⓓ КОМПЛЕКТ ЗАДНИХ КАТКОВ

Ⓕ ZESTAW TYLNYCH WAŁÓW

Farmet

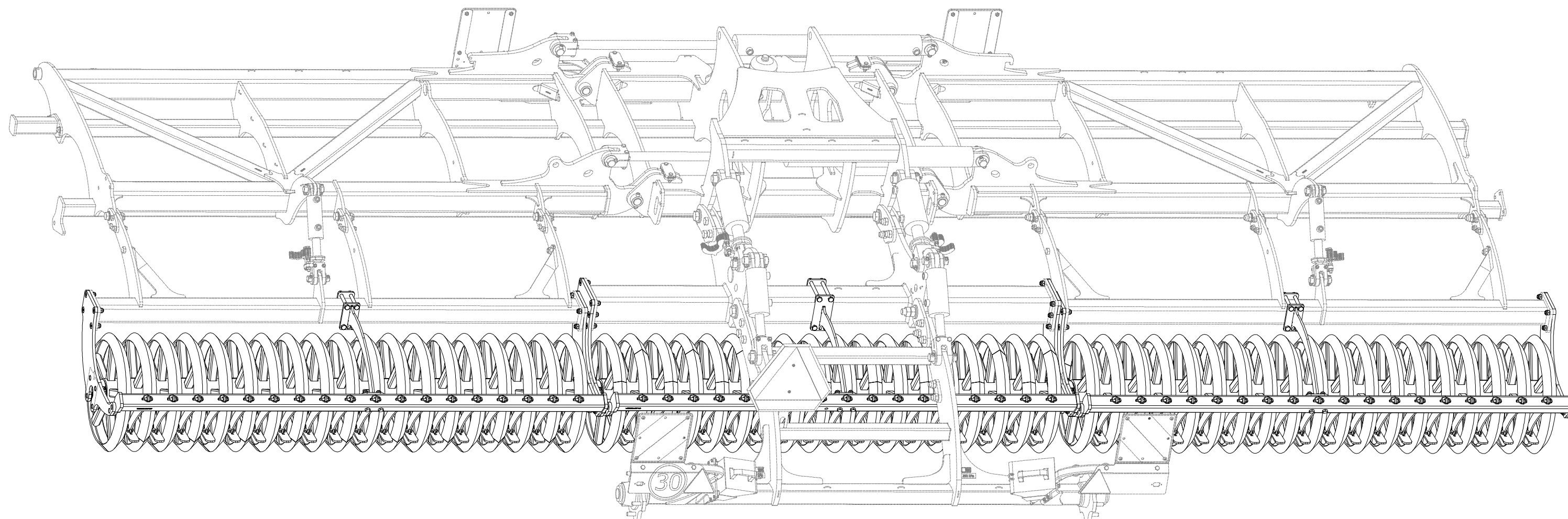

- ⒸZ SADA ZADNÍCH VÁLČŮ
- Ⓓ SATZ HINTERE WALZEN
- Ⓕ KIT DE ROULEAUX ARRIÈRE

- ⒸB SET OF REAR ROLLERS
- ⒲U КОМПЛЕКТ ЗАДНИХ КАТКОВ
- ⒼL ZESTAW TYLNYCH WAŁÓW



VZ00038581

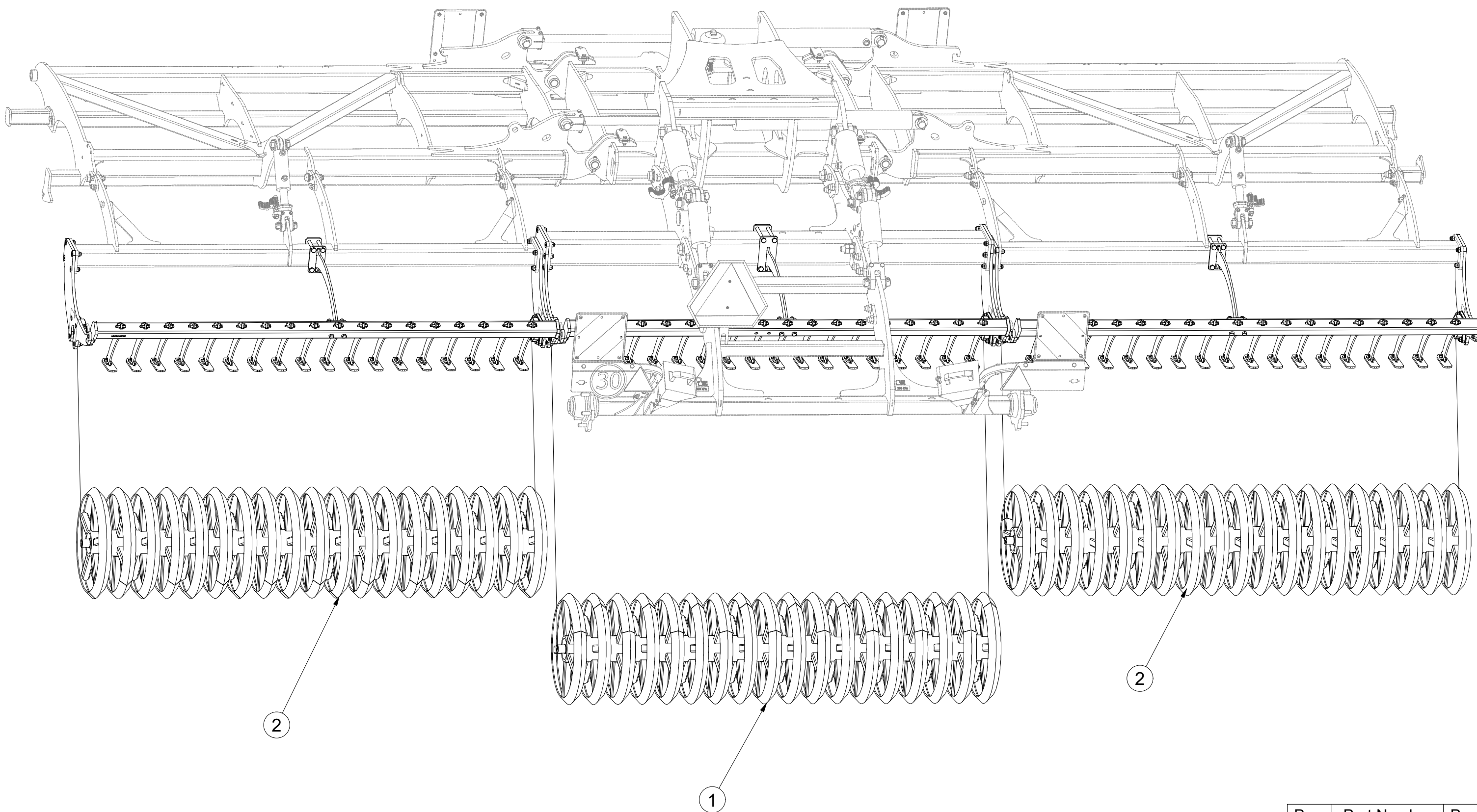

Pos.	Part Number	Pcs.
1	VZ00038561	1
2	VZ00038604	2

- ⒸZ SADA ZADNÍCH VÁLCŮ
- Ⓓ SATZ HINTERE WALZEN
- Ⓕ KIT DE ROULEAUX ARRIÈRE

- ⒸB SET OF REAR ROLLERS
- ⒹU КОМПЛЕКТ ЗАДНИХ КАТКОВ
- ⒹL ZESTAW TYLNYCH WAŁÓW



VZ00038581

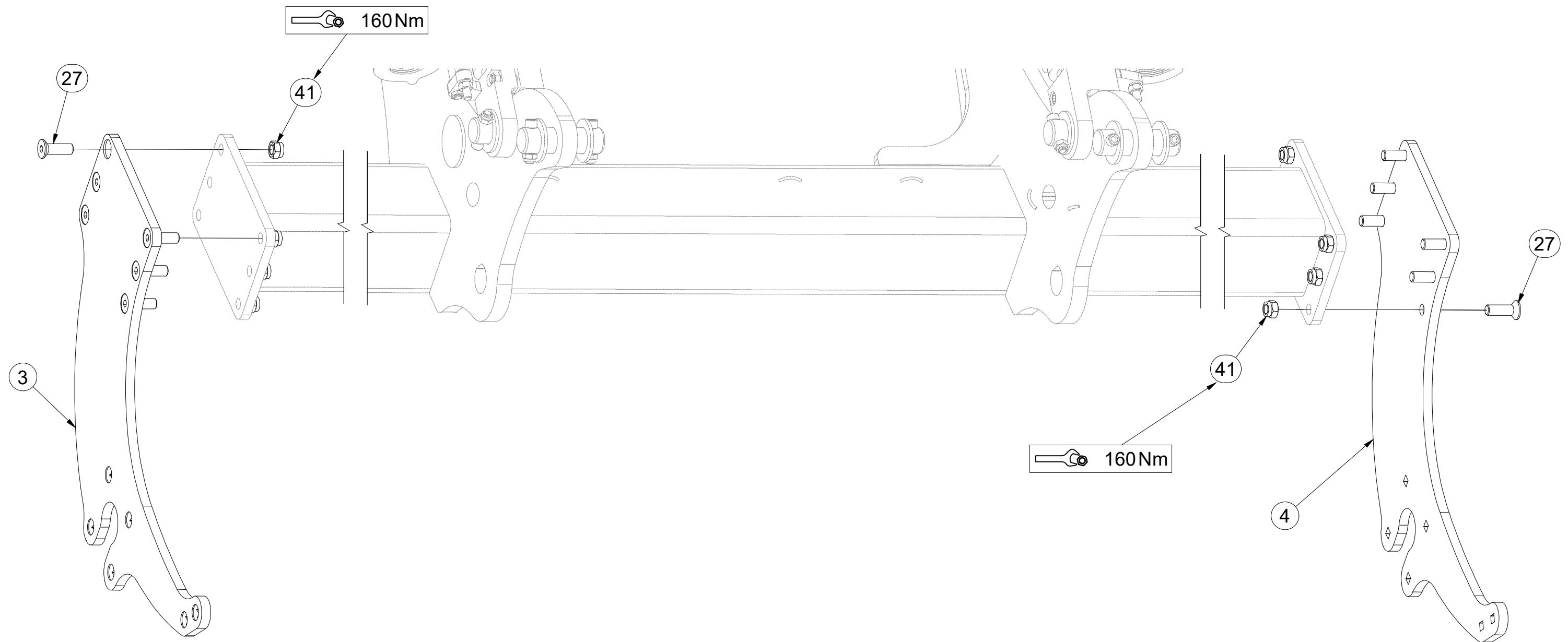
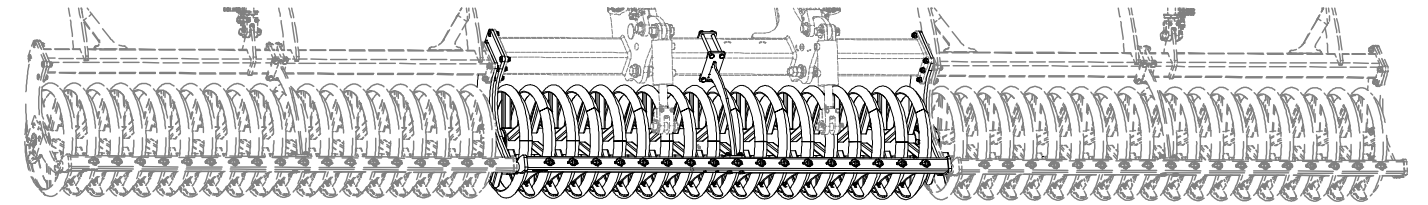

Pos.	Part Number	Pcs.
3	VZ00038590	1
4	VZ00038591	1
27	m14672	28
41	m03683	46

CZ SADA ZADNÍCH VÁLCŮ
 D SATZ HINTERE WALZEN
 F KIT DE ROULEAUX ARRIÈRE

GB SET OF REAR ROLLERS
 RU КОМПЛЕКТ ЗАДНИХ КАТКОВ
 PL ZESTAW TYLNYCH WAŁÓW



VZ00038581

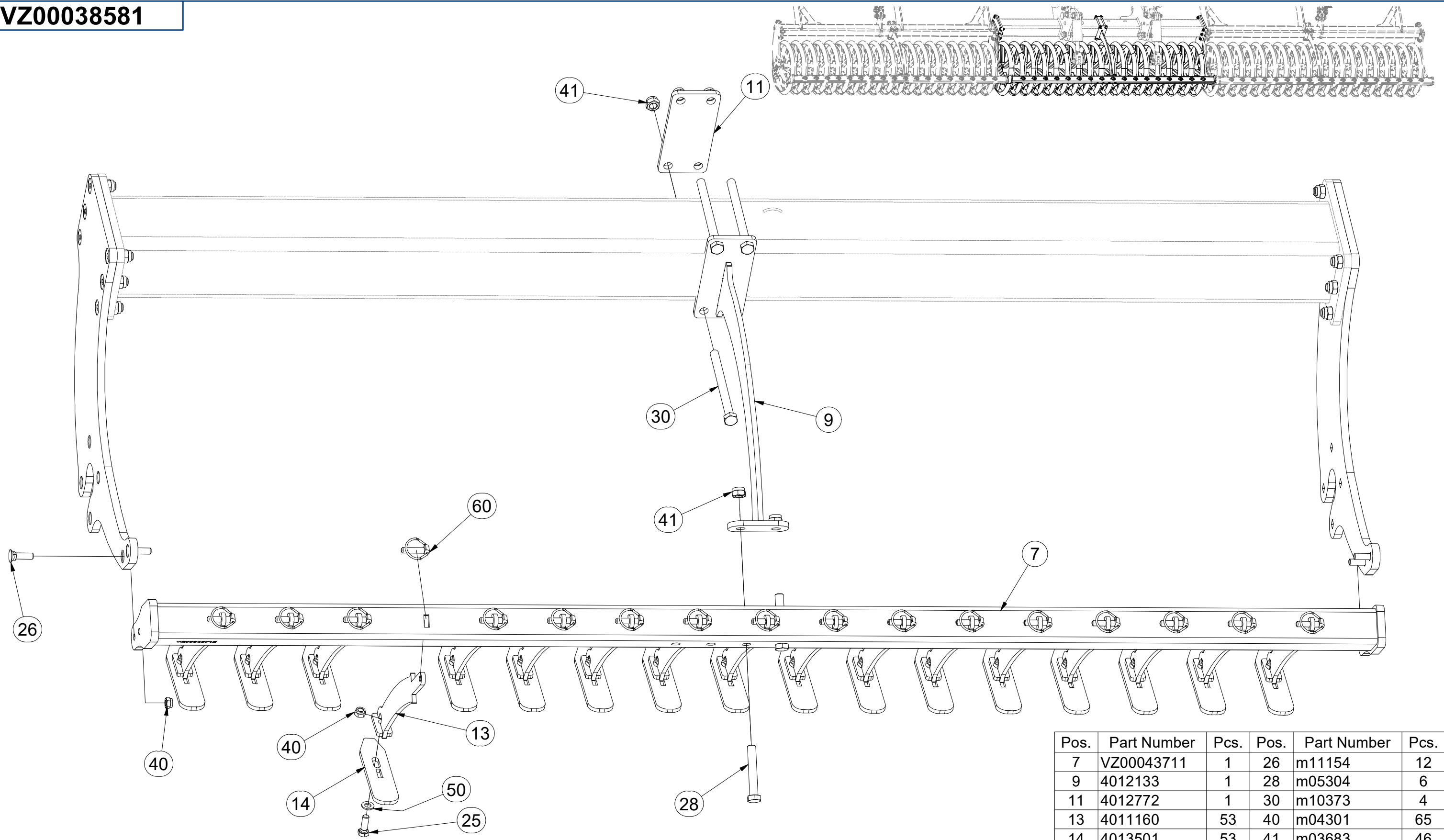

Pos.	Part Number	Pcs.	Pos.	Part Number	Pcs.
7	VZ00043711	1	26	m11154	12
9	4012133	1	28	m05304	6
11	4012772	1	30	m10373	4
13	4011160	53	40	m04301	65
14	4013501	53	41	m03683	46
25	m04343	53	50	m01214	53
			60	m02505	53

- ⒸZ SADA ZADNÍCH VÁLČŮ
- Ⓓ SATZ HINTERE WALZEN
- Ⓕ KIT DE ROULEAUX ARRIÈRE

- ⒸB SET OF REAR ROLLERS
- ⒸR КОМПЛЕКТ ЗАДНИХ КАТКОВ
- ⒸL ZESTAW TYLNYCH WAŁÓW



VZ00038581

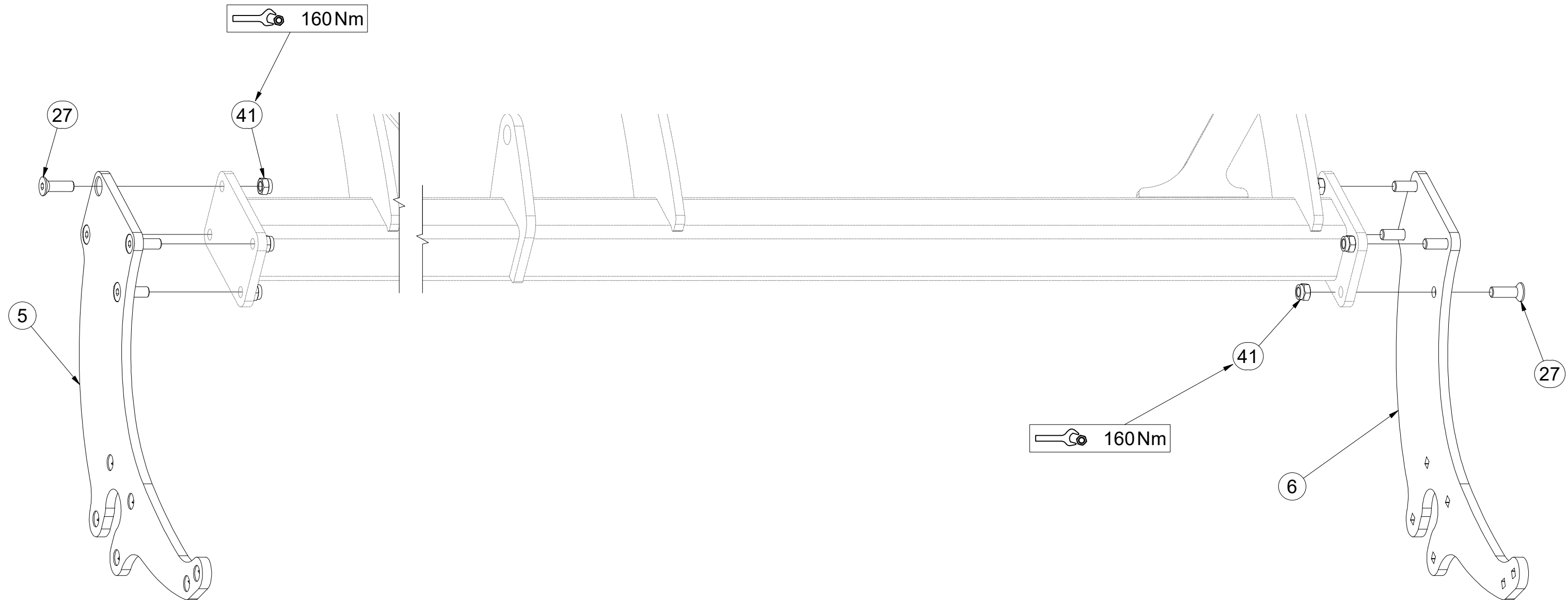
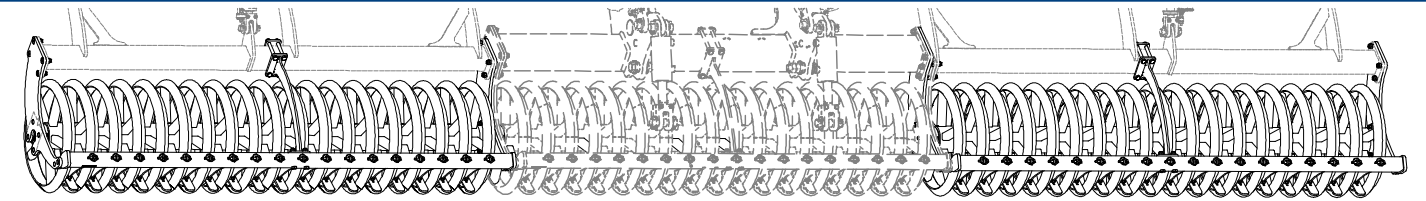

Pos.	Part Number	Pcs.
5	VZ00037388	2
6	VZ00037389	2
27	m14672	28
41	m03683	46

- Ⓒ SADA ZADNÍCH VÁLCŮ
- Ⓓ SATZ HINTERE WALZEN
- Ⓕ KIT DE ROULEAUX ARRIÈRE

- Ⓒ SET OF REAR ROLLERS
- Ⓓ КОМПЛЕКТ ЗАДНИХ КАТКОВ
- Ⓕ ZESTAW TYLNYCH WAŁÓW



VZ00038581

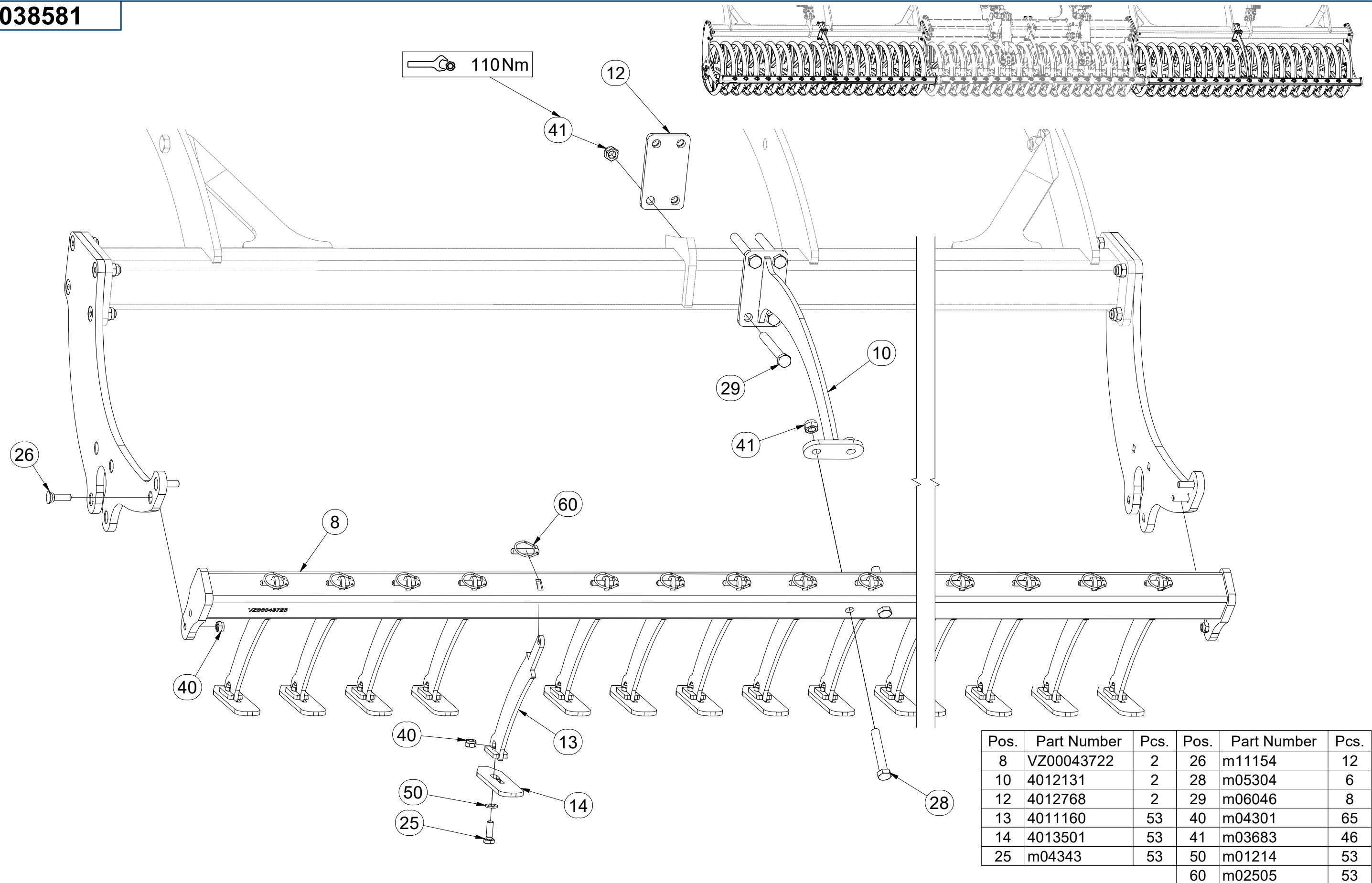

Pos.	Part Number	Pcs.	Pos.	Part Number	Pcs.
8	VZ00043722	2	26	m11154	12
10	4012131	2	28	m05304	6
12	4012768	2	29	m06046	8
13	4011160	53	40	m04301	65
14	4013501	53	41	m03683	46
25	m04343	53	50	m01214	53
			60	m02505	53

- Ⓒ SADA ZADNÍCH VÁLCŮ
- Ⓓ SATZ HINTERE WALZEN
- Ⓕ KIT DE ROULEAUX ARRIÈRE

- Ⓖ SET OF REAR ROLLERS
- Ⓡ КОМПЛЕКТ ЗАДНИХ КАТКОВ
- Ⓟ ZESTAW TYLNYCH WAŁÓW



VZ00038581

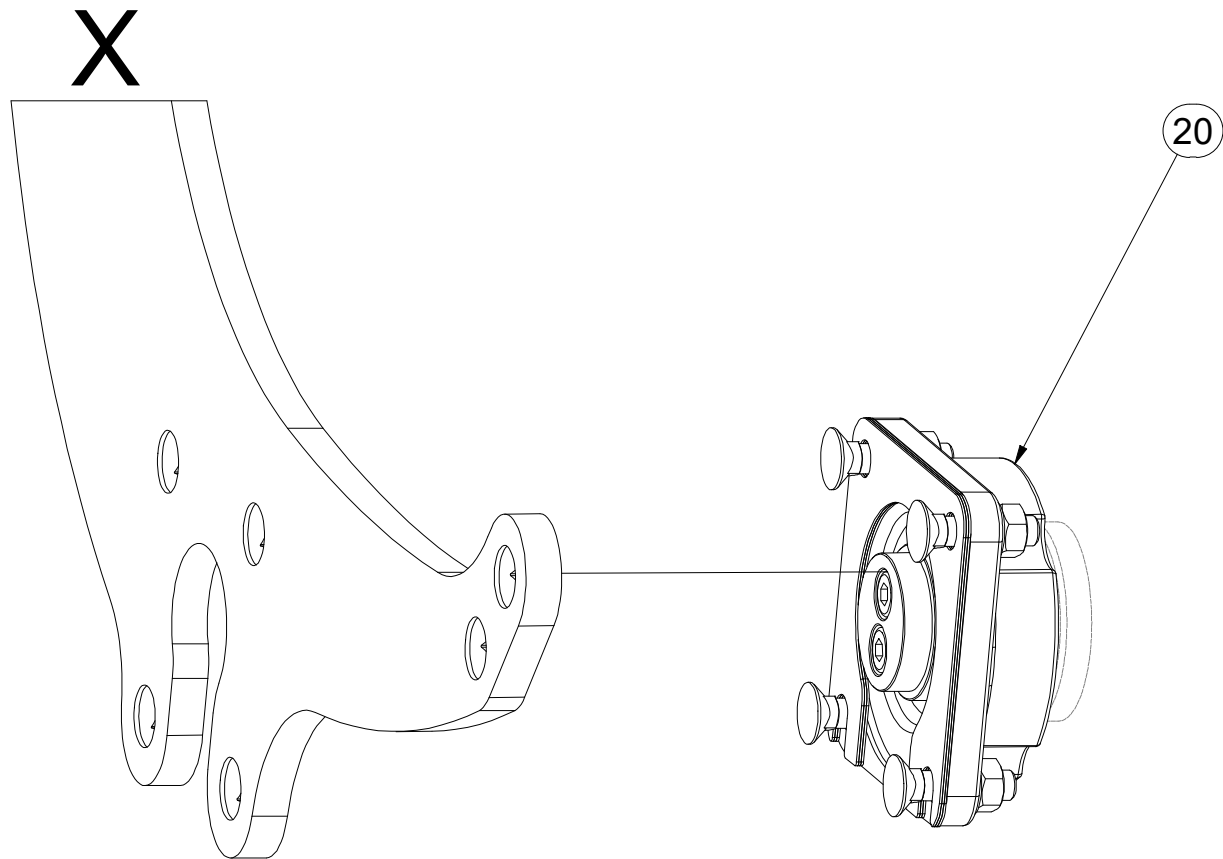
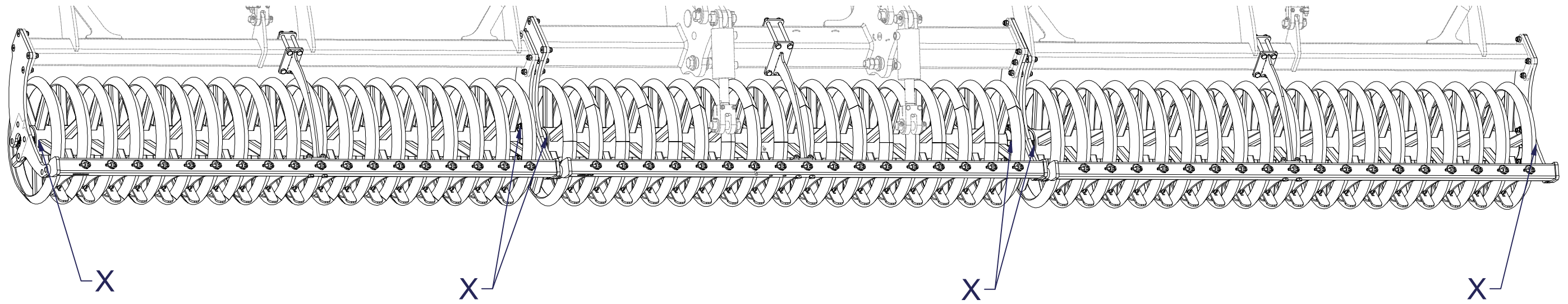

Pos.	Part Number	Pcs.
20	VZ00033348	6

CZ SADA LOŽISEK
 D SATZ LAGER
 F KIT DE ROULEMENTS

GB SET OF BEARINGS
 RU КОМПЛЕКТ ПОДШИПНИКОВ
 PL ZESTAW ŁOŻYSK



VZ00033348

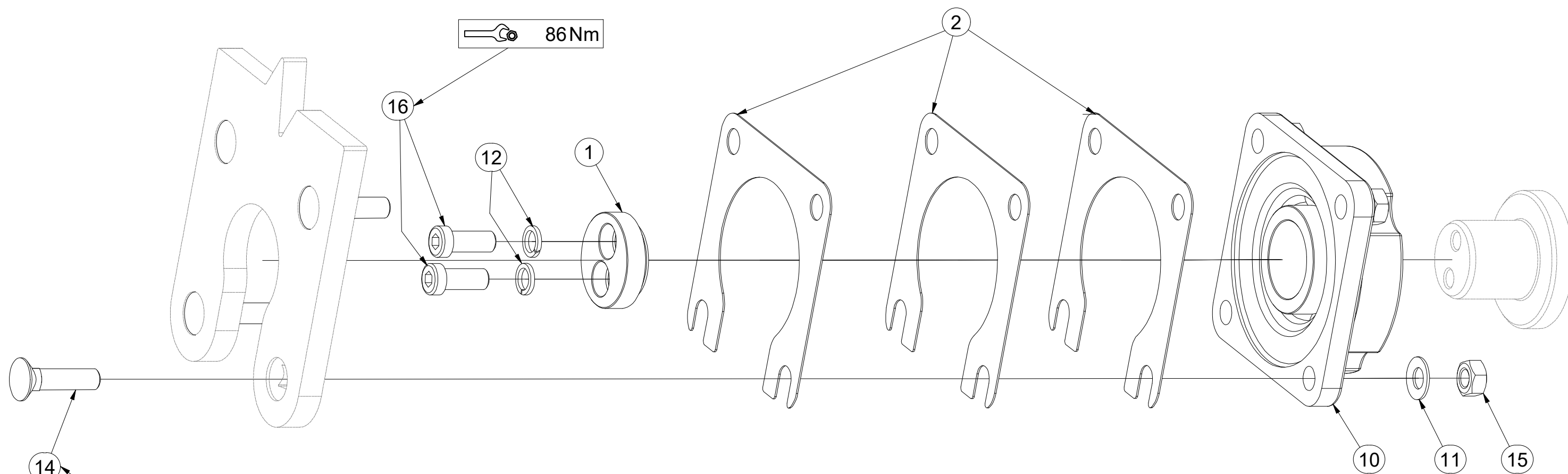
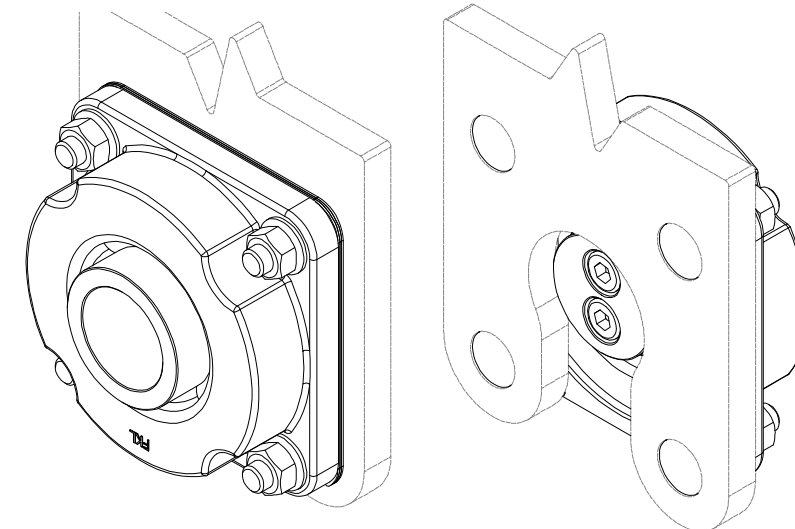

Pos.	Part Number	Pcs.
1	VZ00038447	1
2	VZ00030606	3
10	m17627	1
11	m17545	4
12	m03988	2
14	m10440	4
15	m10439	4
16	m19122	2

VZ00039937

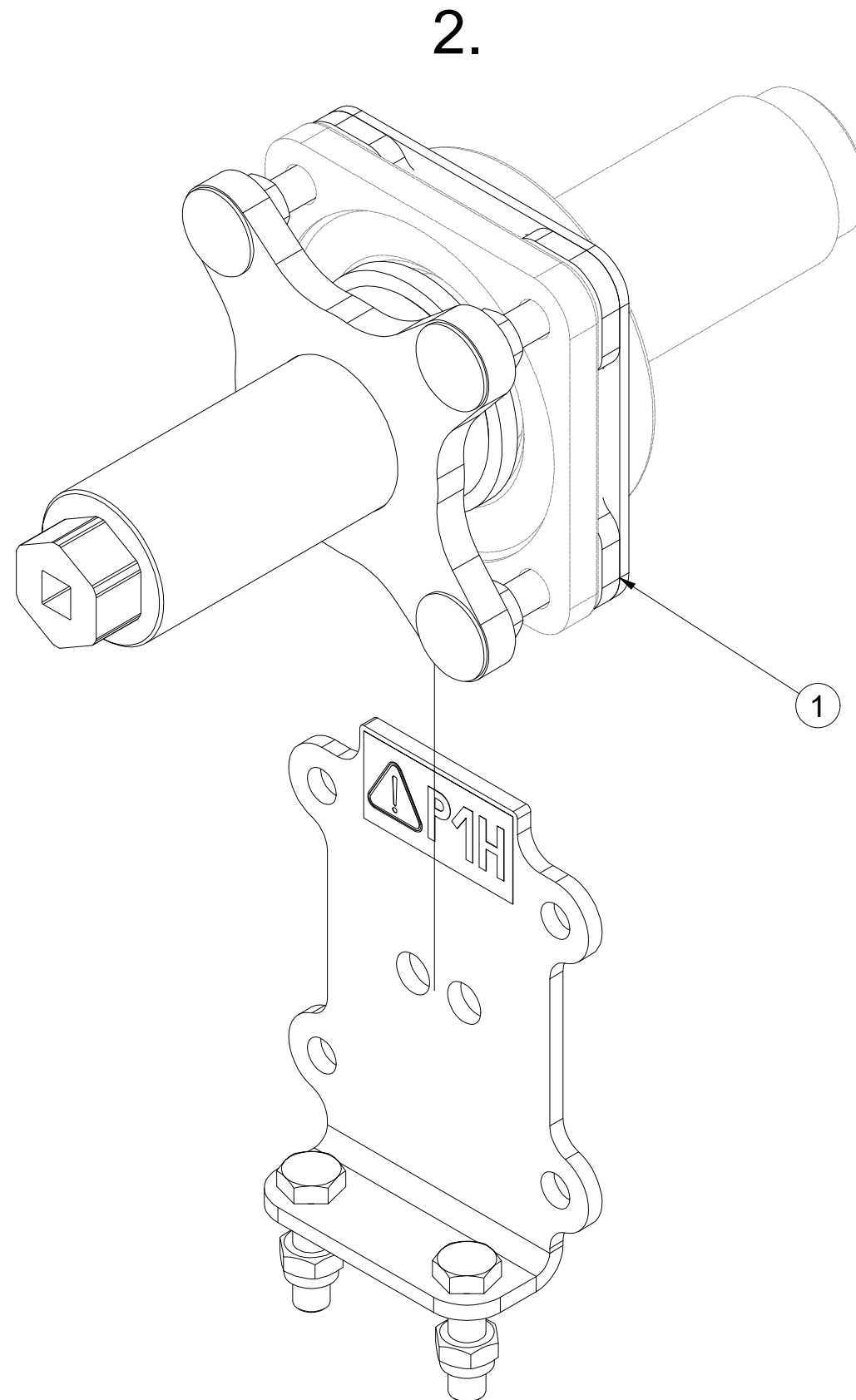
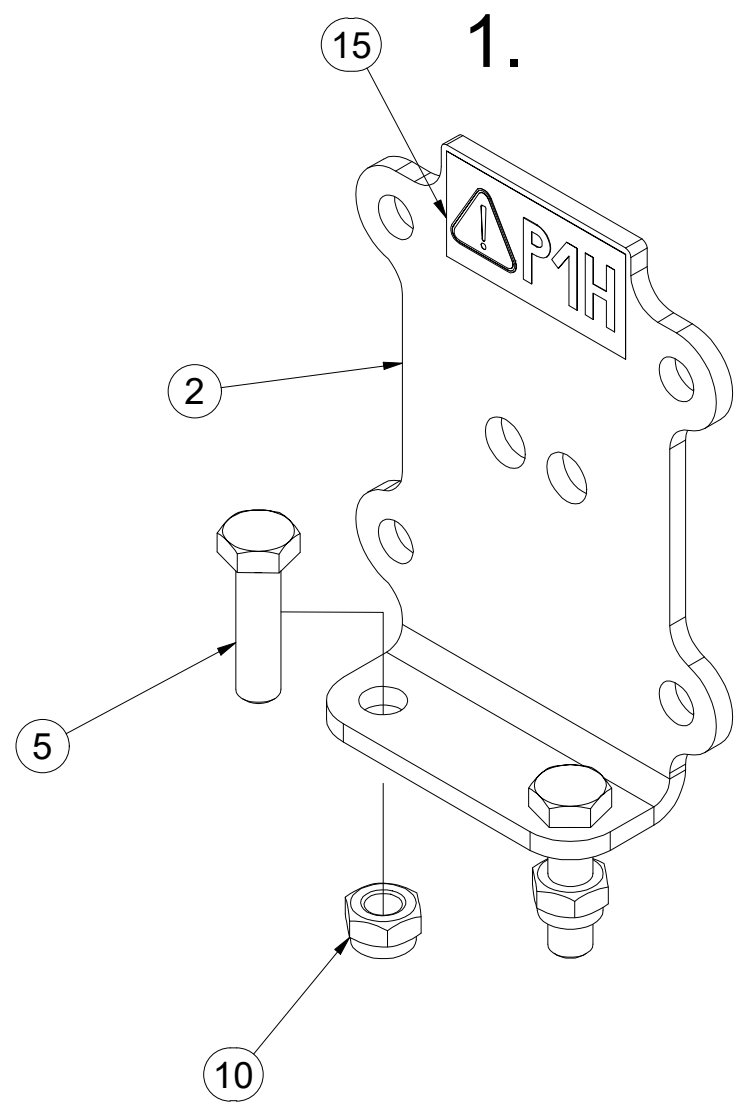

Pos.	Part Number	Pcs.
1	VZ00038848	1
2	VZ00039933	1
5	m06077	2
10	m04301	2
15	m04359	1

VZ00038848

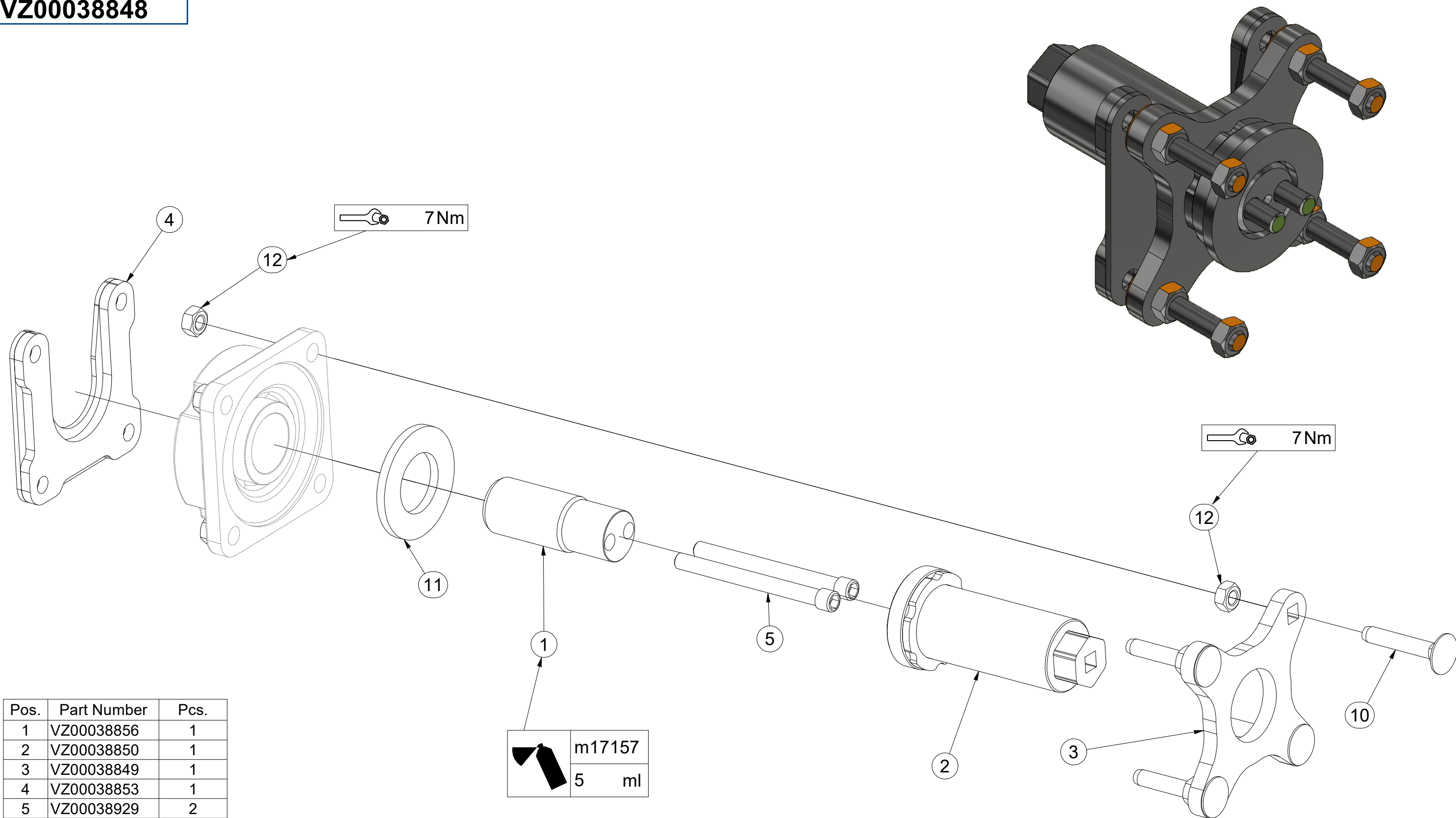

Pos.	Part Number	Pcs.
1	VZ00038856	1
2	VZ00038850	1
3	VZ00038849	1
4	VZ00038853	1
5	VZ00038929	2
10	m17684	4
11	m05447	1
12	m10439	8
20	m17157	5,00 ml

- Ⓒ SADA NÁPRAVY
- Ⓓ SATZ AUFHÄNGUNG
- Ⓕ KIT DE L'ESSIEU

- Ⓒ AXLE SET
- Ⓓ КОМПЛЕКТ ОСИ КОЛЁС
- Ⓕ ZESTAW OSI



VZ00018117

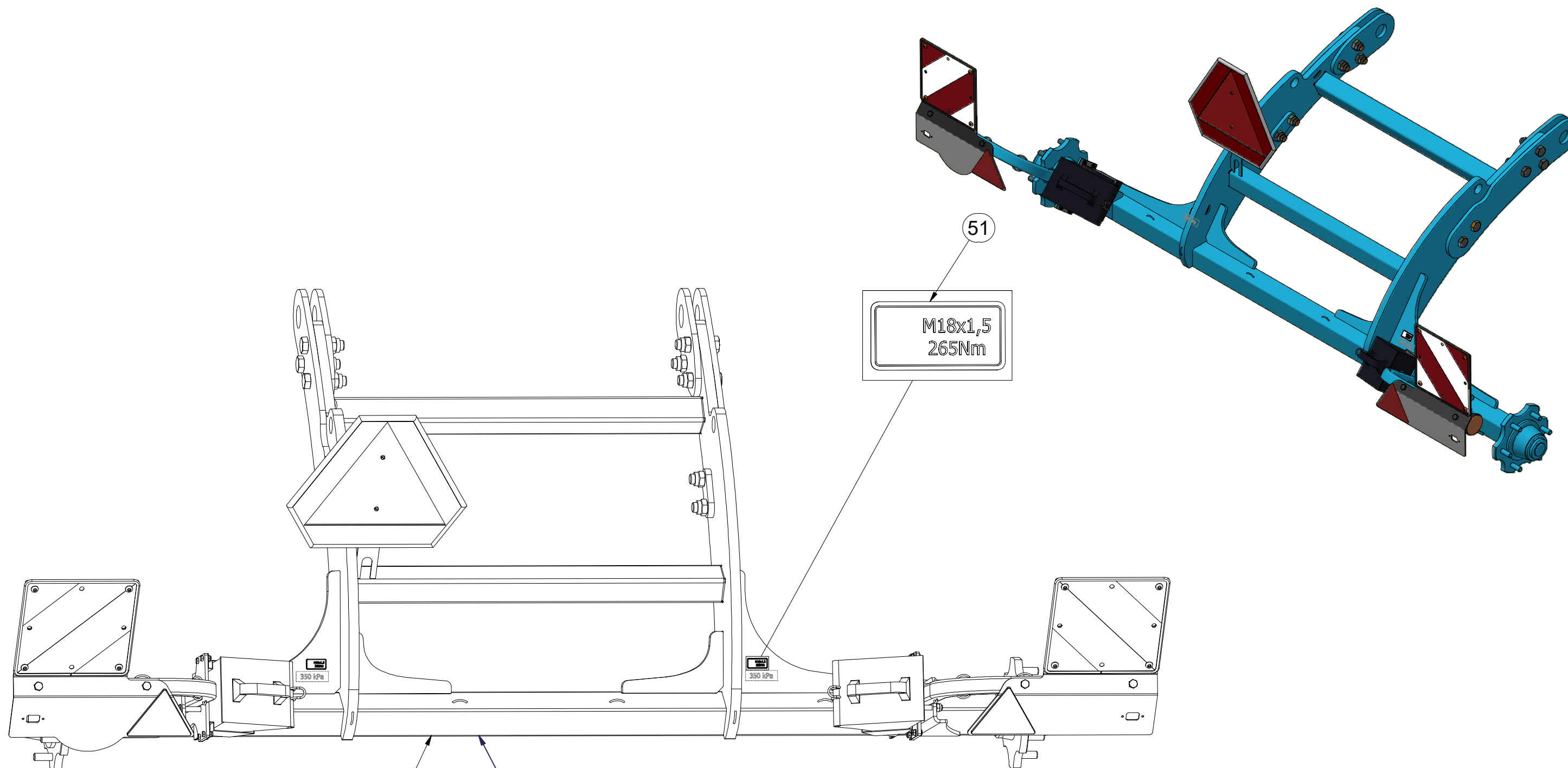

1

A80RM600012

Pos.	Part Number	Pcs.
1	2001187	1
51	m19732	2

Ⓒ SADA NÁPRAVY

Ⓓ SATZ AUFHÄNGUNG

Ⓕ KIT DE L'ESSIEU

Ⓒ AXLE SET

Ⓓ КОМПЛЕКТ ОСИ КОЛЁС

Ⓕ ZESTAW OSI



VZ00018117

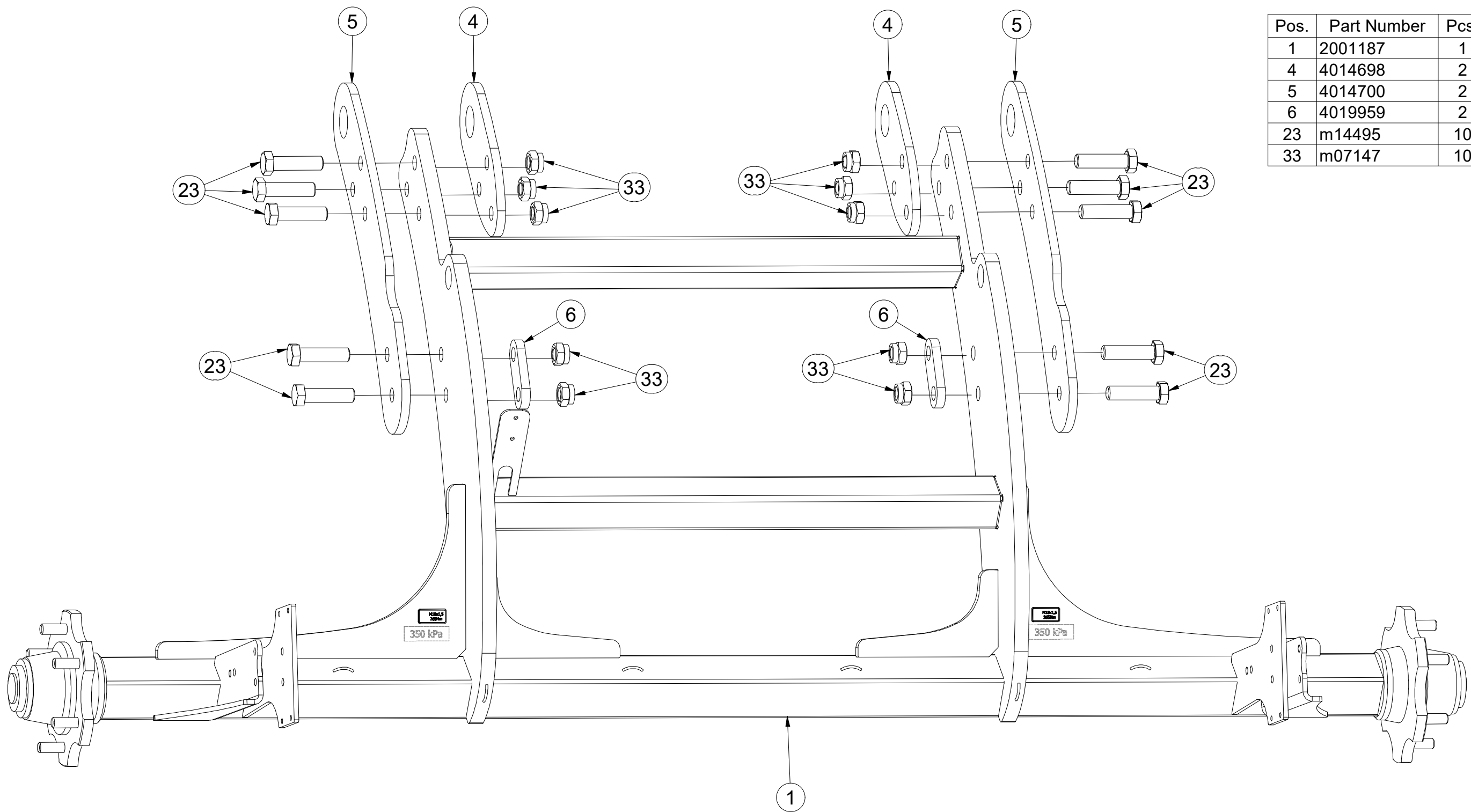

Pos.	Part Number	Pcs.
1	2001187	1
4	4014698	2
5	4014700	2
6	4019959	2
23	m14495	10
33	m07147	10

ⒸZ SADA NÁPRAVY

Ⓓ SATZ AUFHÄNGUNG

Ⓕ KIT DE L'ESSIEU

ⒸB AXLE SET

Ⓔ КОМПЛЕКТ ОСИ КОЛЁС

Ⓗ ZESTAW OSI



VZ00018117

Pos.	Part Number	Pcs.
1	2001187	1
2	3012367	1
21	m01089	8
22	m12493	6
31	m04503	8
32	m04301	6
36	m01203	8
37	m01214	6
40	m16186	2
41	m12572	2

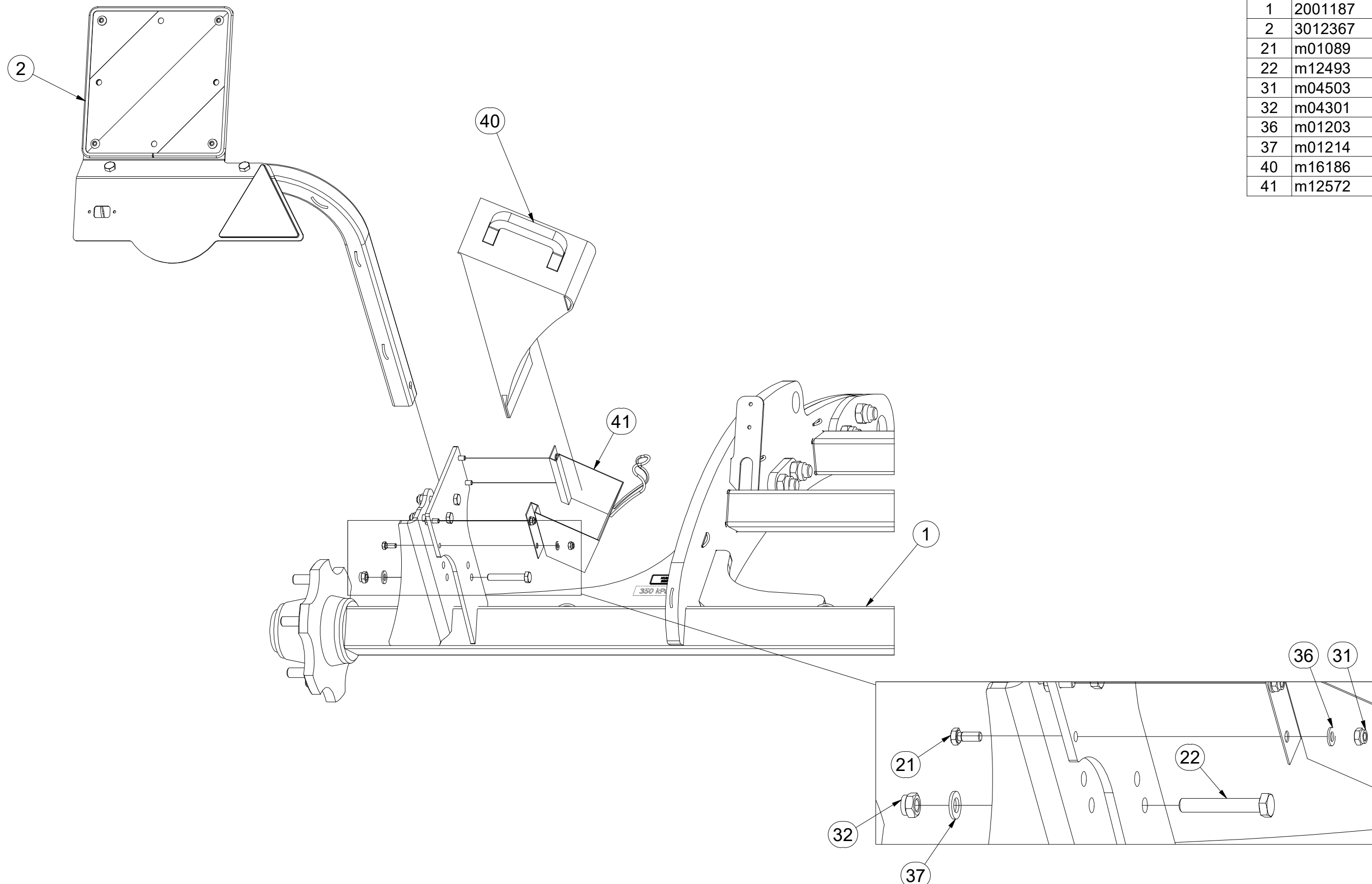

Ⓒ SADA NÁPRAVY

Ⓓ SATZ AUFHÄNGUNG

Ⓕ KIT DE L'ESSIEU

Ⓖ AXLE SET

Ⓡ КОМПЛЕКТ ОСИ КОЛЁС

Ⓢ ZESTAW OSI



VZ00018117

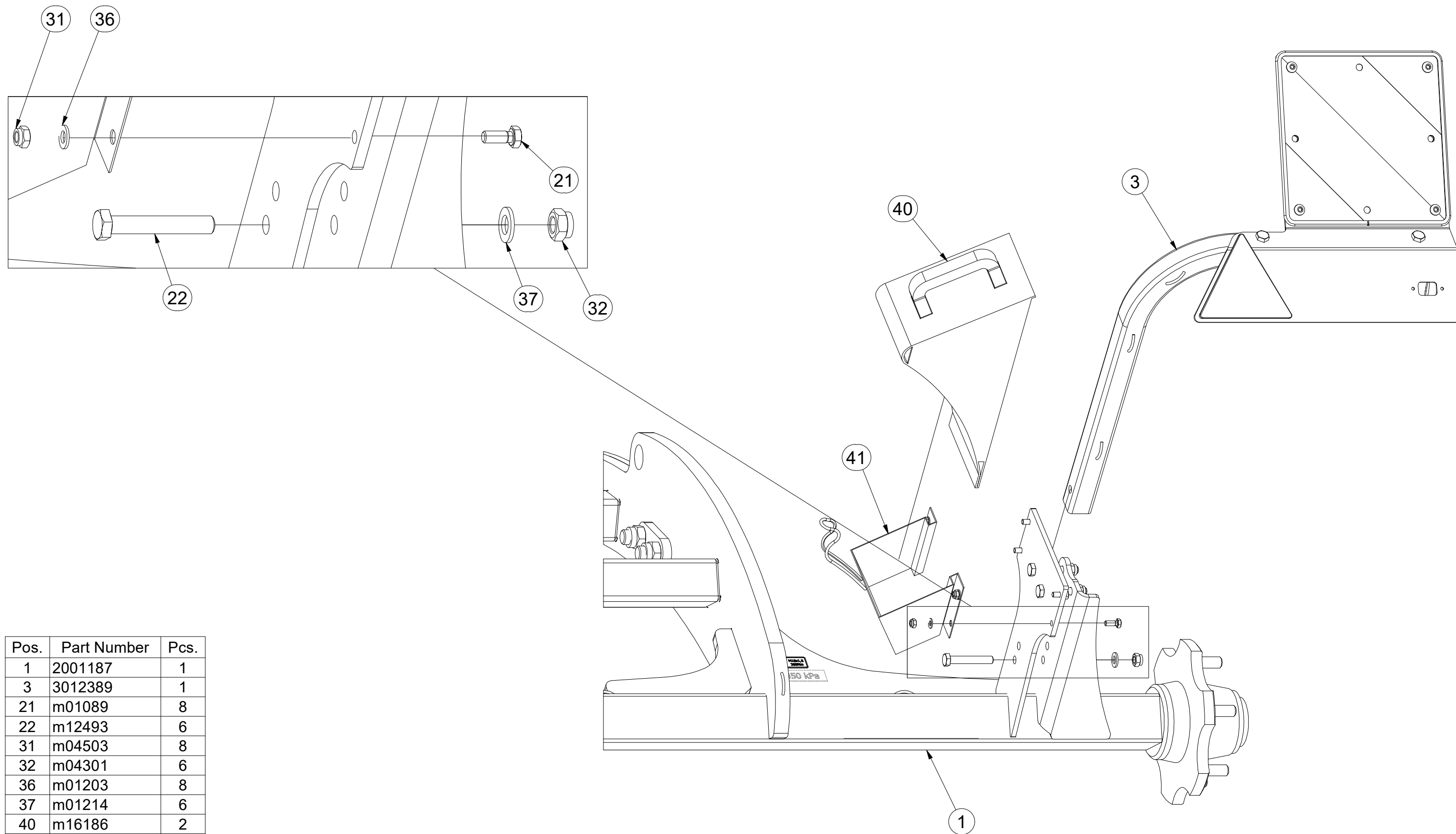

Pos.	Part Number	Pcs.
1	2001187	1
3	3012389	1
21	m01089	8
22	m12493	6
31	m04503	8
32	m04301	6
36	m01203	8
37	m01214	6
40	m16186	2
41	m12572	2

Ⓒ SADA NÁPRAVY

Ⓓ SATZ AUFHÄNGUNG

Ⓕ KIT DE L'ESSIEU

Ⓖ AXLE SET

Ⓡ КОМПЛЕКТ ОСИ КОЛЁС

Ⓢ ZESTAW OSI



VZ00018117

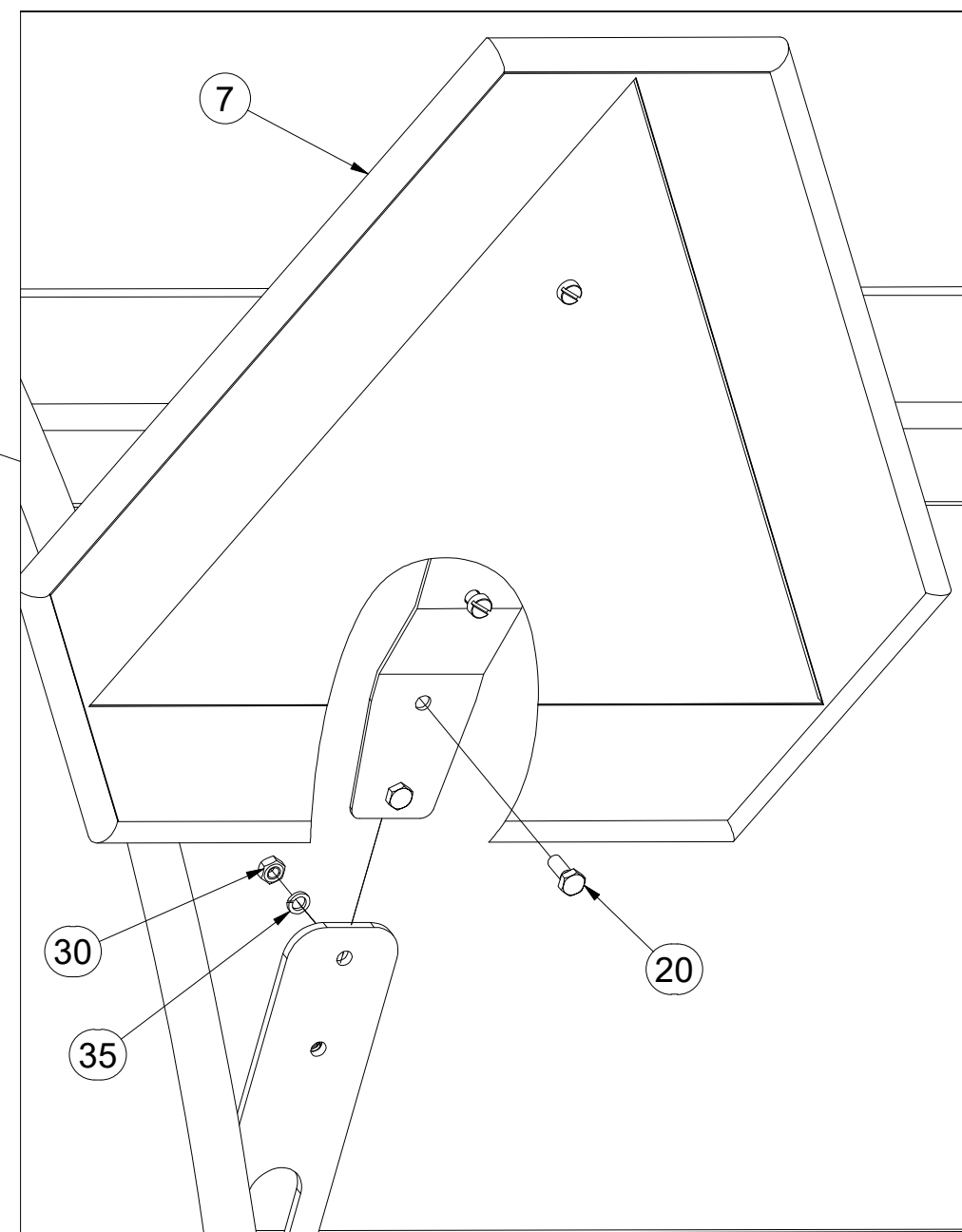
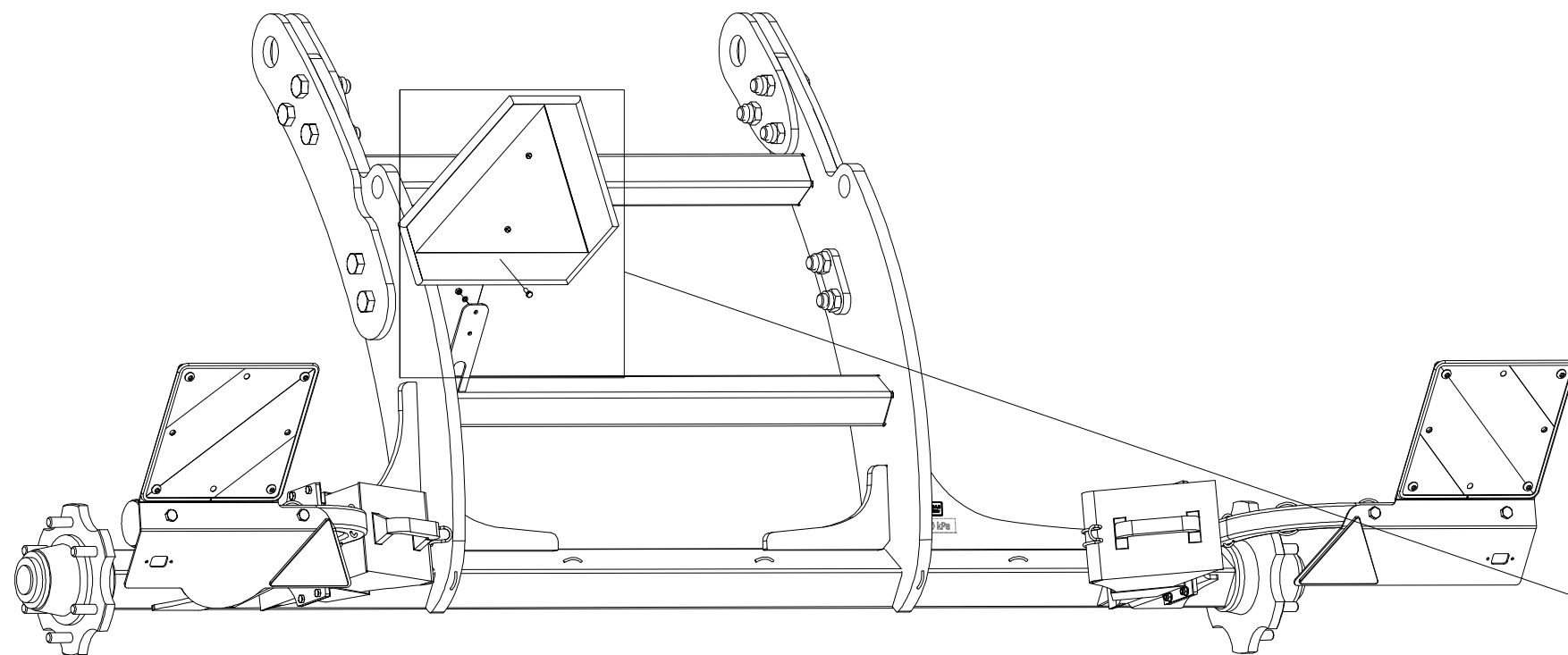

Pos.	Part Number	Pcs.
7	4007398	1
20	m01073	2
30	m01295	2
35	m01200	2

Ⓒ NÁPRAVA

Ⓓ ACHSE

Ⓕ ESSIEU

Ⓒ AXLE

Ⓓ OCB

Ⓕ OS



A80RM60012

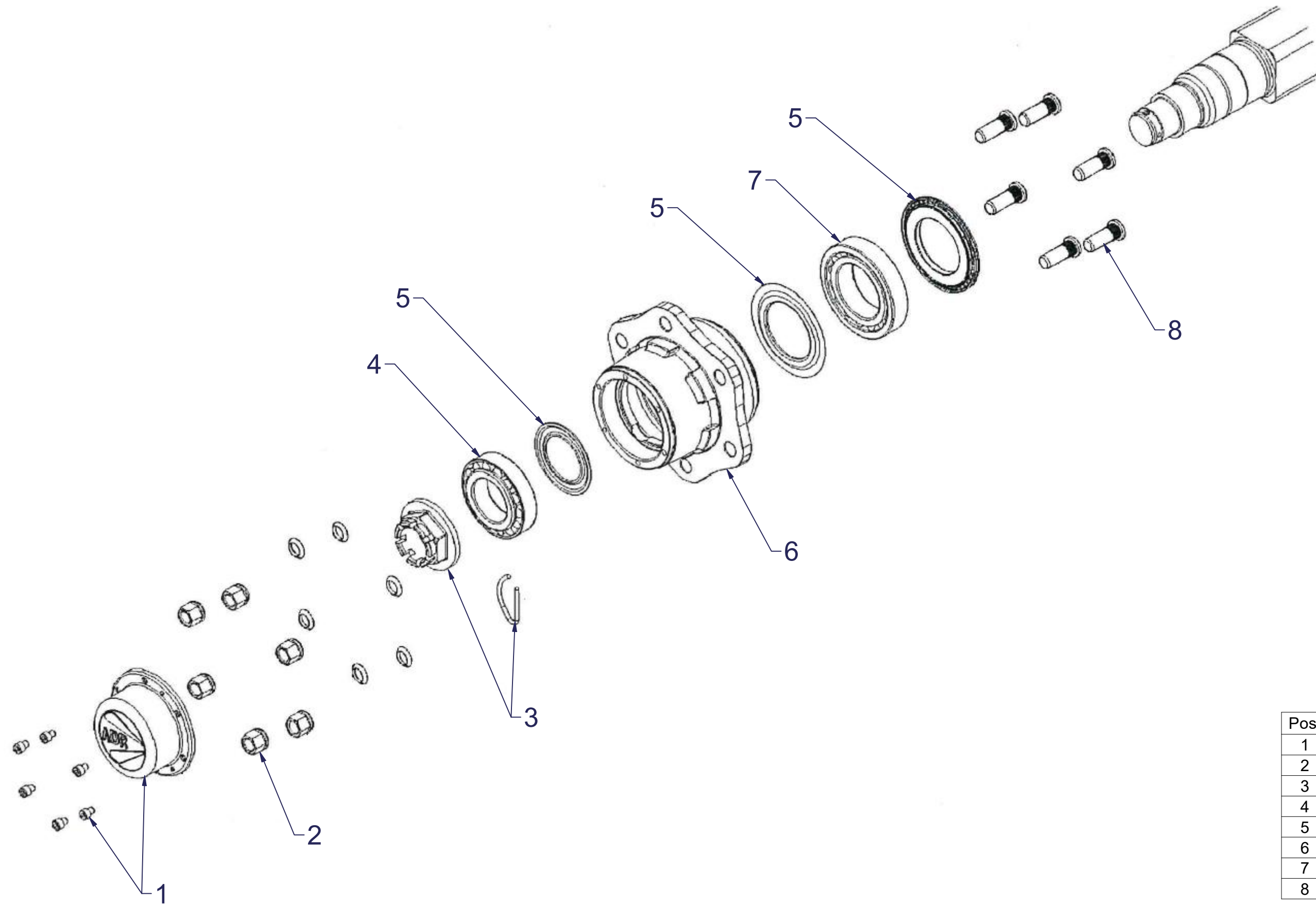

Pos.	Part Number	Pcs.
1	m12566	2
2	m08163	12
3	m08168	2
4	m07153	2
5	m08156	2
6	m12567	2
7	m07154	2
8	m08148	12

Ⓒ SADA NÁPRAVY

Ⓓ SATZ AUFHÄNGUNG

Ⓕ KIT DE L'ESSIEU

VZ00018118

Ⓖ AXLE SET

Ⓡ КОМПЛЕКТ ОСИ КОЛЁС

Ⓢ ZESTAW OSI

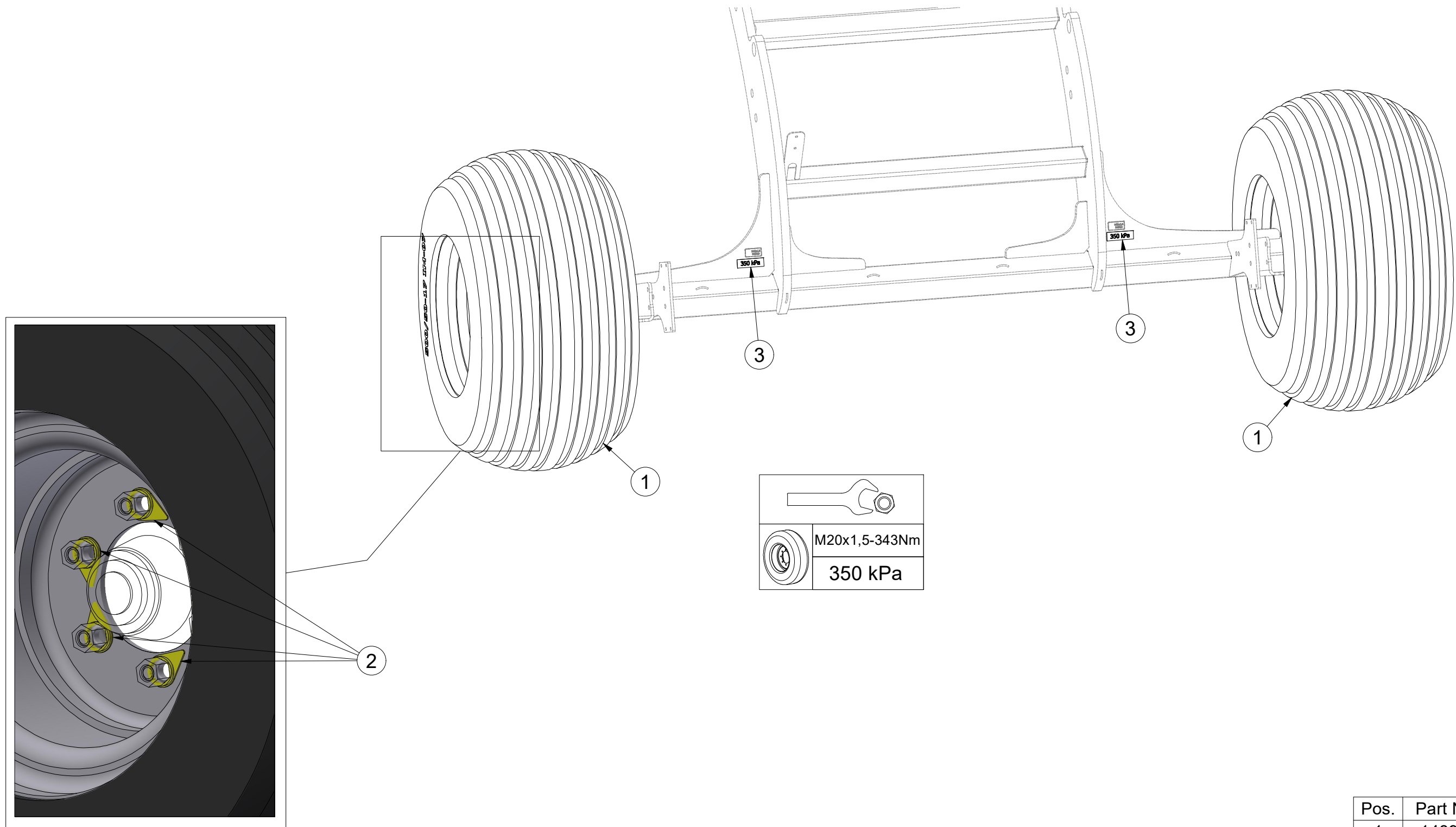

Pos.	Part Number	Pcs.
1	m14895	2
2	m19657	12
3	m08845	2

ⒸZ TERČ ZADNÍ LEVÝ

Ⓓ SCHILD, HINTERES, LINKES

Ⓕ CIBLE ARRIÈRE GAUCHE

3012367

ⒼB LEFT REAR DISC

ⒺЩИТОК ЗАДНИЙ ЛЕВЫЙ

ⒽL TARCZA TYLNA LEWA

Farmet

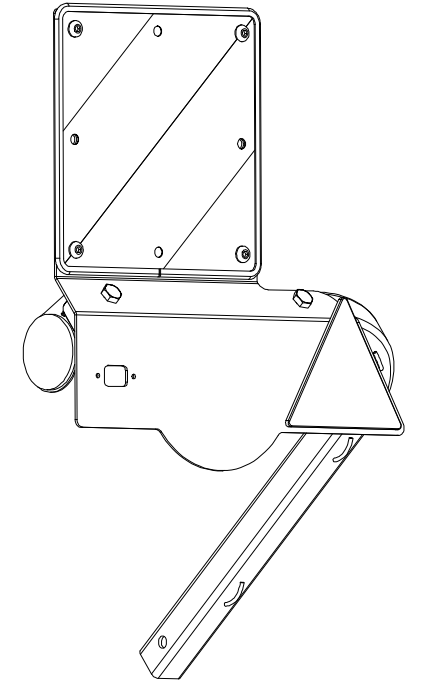
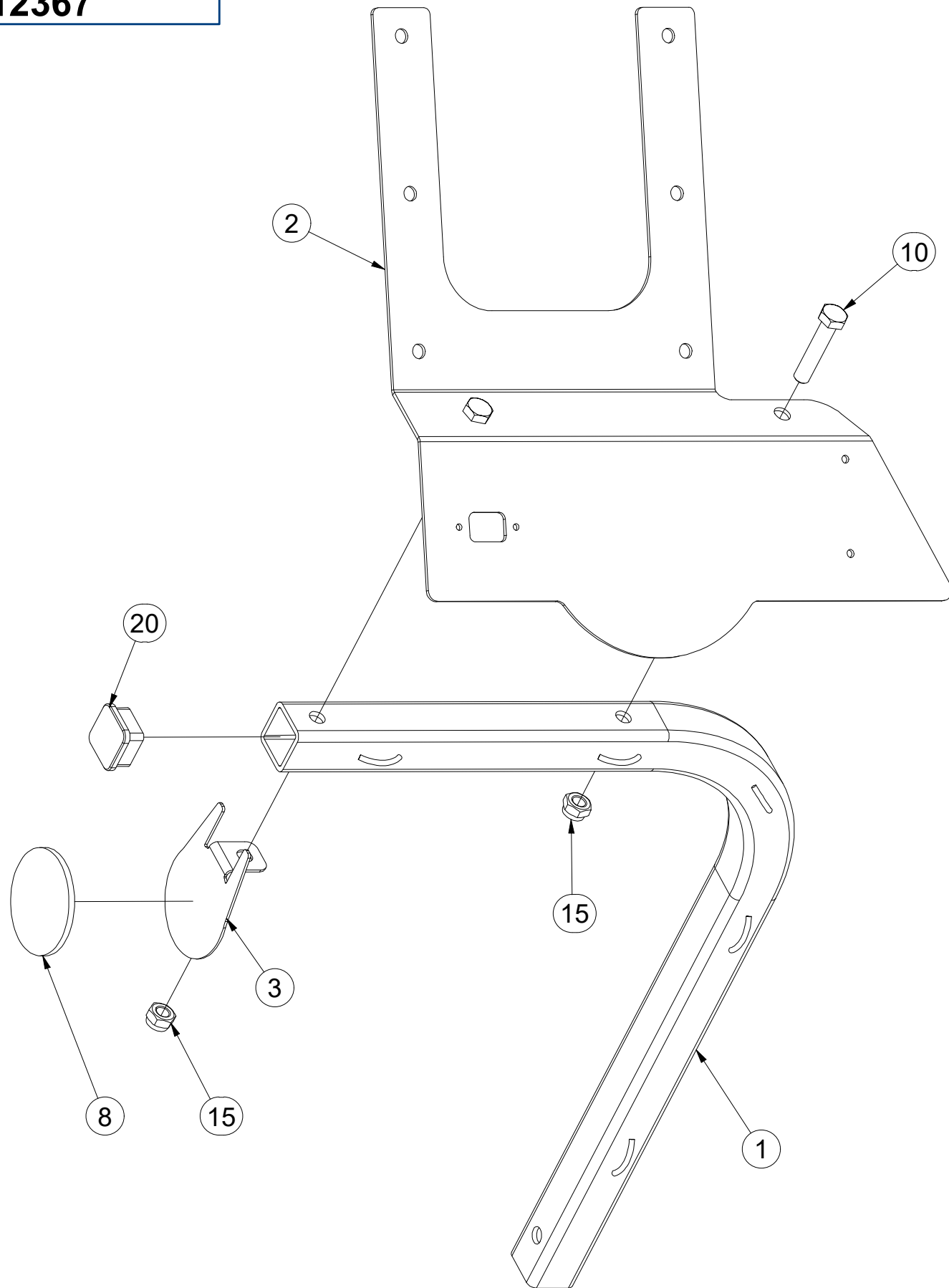

Pos.	Part Number	Pcs.
1	3012364	1
2	3012365	1
3	4024926	1
8	m02579	1
10	m01131	2
15	m04301	2
20	m12689	1

ⒸZ TERČ ZADNÍ LEVÝ

Ⓓ SCHILD, HINTERES, LINKES

Ⓕ CIBLE ARRIÈRE GAUCHE

ⒼB LEFT REAR DISC

ⒺЩИТОК ЗАДНИЙ ЛЕВЫЙ

ⒽL TARCZA TYLNA LEWA

Farmet

3012367

Pos.	Part Number	Pcs.
5	m18855	1
6	9005707	1
7	m02497	1
11	m16637	4
16	m03775	4
25	m01209	4

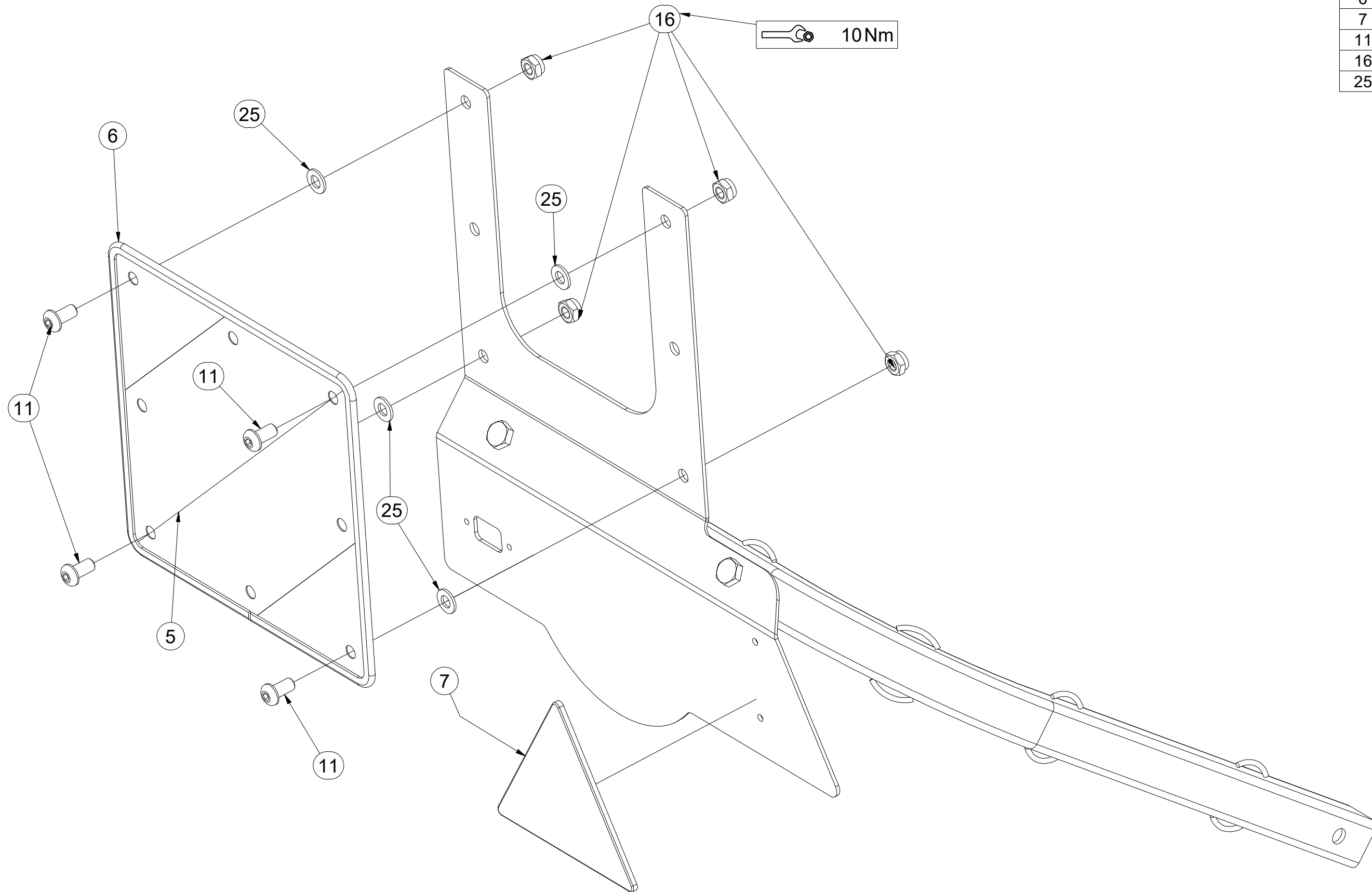

ⒸZ TERČ ZADNÍ PRAVÝ

Ⓓ SCHILD, HINTERES, RECHTES

Ⓕ CIBLE ARRIÈRE DROITE

3012389

ⒼB RIGHT REAR DISC

ⒺЩИТОК ЗАДНИЙ ПРАВЫЙ

ⒽL TARCZA TYLNA PRAWA

Farmet

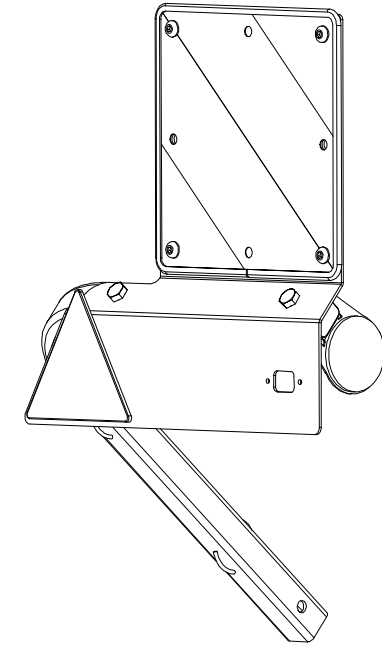
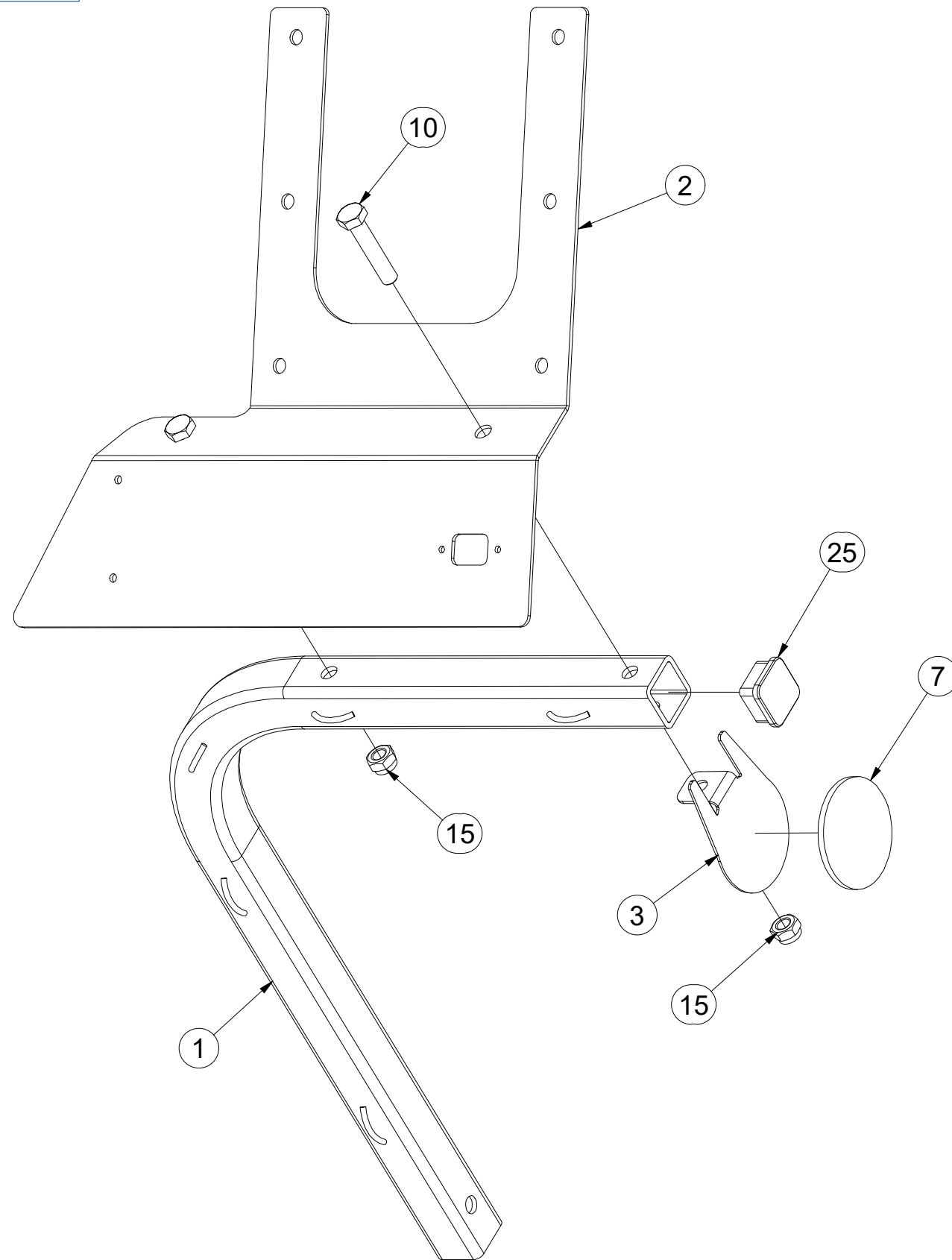

Pos.	Part Number	Pcs.
1	3012364	1
2	3012390	1
3	4024926	1
7	m02579	1
10	m01131	2
15	m04301	2
25	m12689	1

ⒸZ TERČ ZADNÍ PRAVÝ

Ⓓ SCHILD, HINTERES, RECHTES

Ⓕ CIBLE ARRIÈRE DROITE

ⒼB RIGHT REAR DISC

ⒺЩИТОК ЗАДНИЙ ПРАВЫЙ

ⒽL TARCZA TYLNA PRAWA



3012389

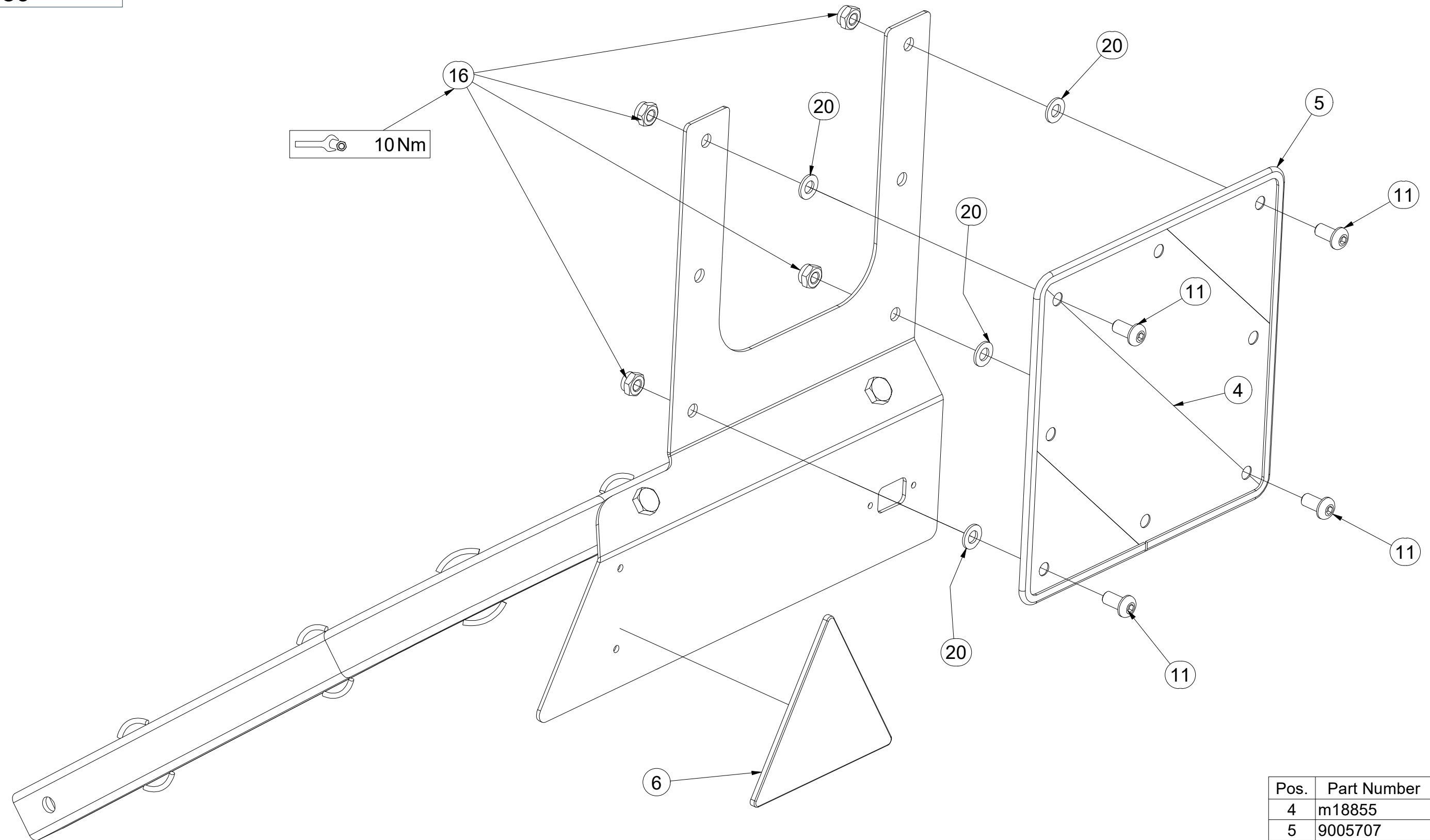

Pos.	Part Number	Pcs.
4	m18855	1
5	9005707	1
6	m02497	1
11	m16637	4
16	m03775	4
20	m01209	4

Ⓒ VÝSTRAŽNÝ TROJÚHELNÍK

Ⓓ WARNDREIECK

Ⓕ TRIANGLE D'AVERTISSEMENT

Ⓖ EMERGENCY TRIANGLE

Ⓡ ЗНАК АВАРИЙНОЙ ОСТАНОВКИ

Ⓟ TRÓJKAT OSTRZEGAWCZY

Farmet

4007398

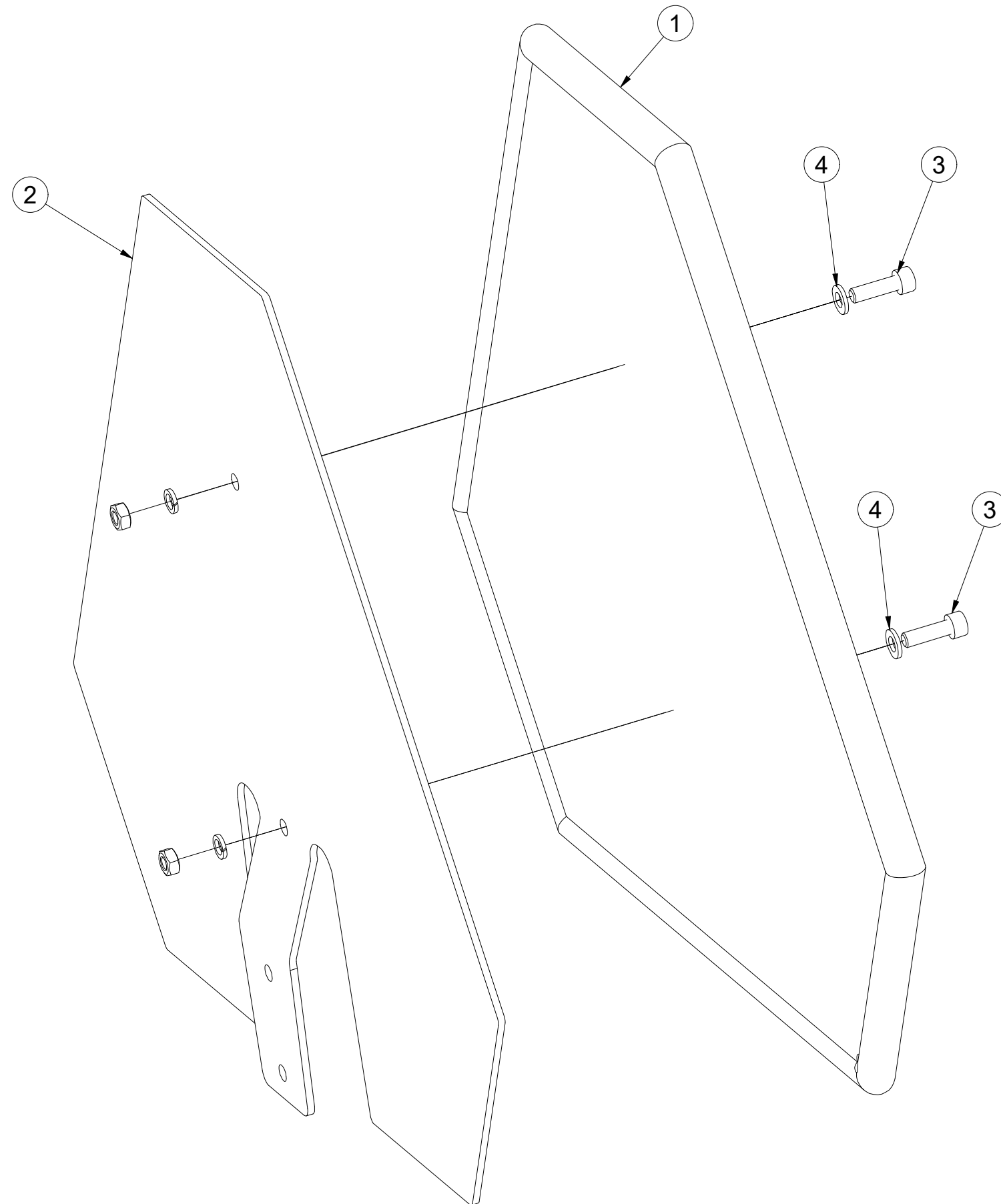
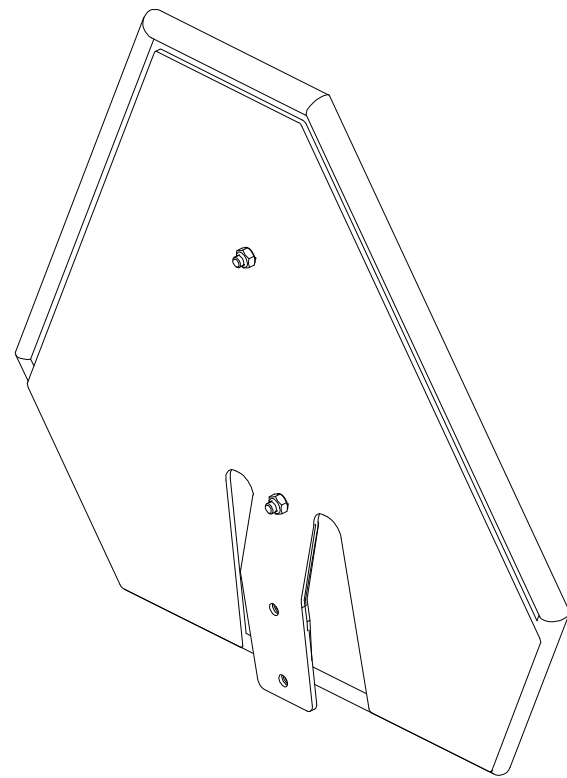

Pos.	Part Number	Pcs.
1	m05371	1
2	3003785	1
3	m04346	2
4	m01199	2

ⒸZ HYDRAULICKÝ ROZVOD SKLÁPĚNÍ

Ⓓ HYDRAULISCHE VERTEILUNG KLAPPMECHANISMUS

Ⓕ CONDUIT HYDRAULIQUE DU BASCULEMENT

ⒸB HYDRAULIC FOLDING DISTRIBUTION

ⒸU ГИДРАВЛИЧЕСКОЕ РАСПРЕДЕЛЕНИЕ СКЛАДЫВАНИЯ

ⒸL HYDRAULICZNY PRZEWÓD SKŁADANIA



VZ00017410

Pos.	Part Number	Pcs.	Pos.	Part Number	Pcs.
2	m07645	1	39	m10777	1
3	m20170	1	45	m03849	2
8	m07648	2	46	m04022	2
9	m11696	2	47	m11294	42
18	m09911	1	48	m11183	1
21	m06528	8	60	m13696	2
30	m03213	3	65	m05560	2

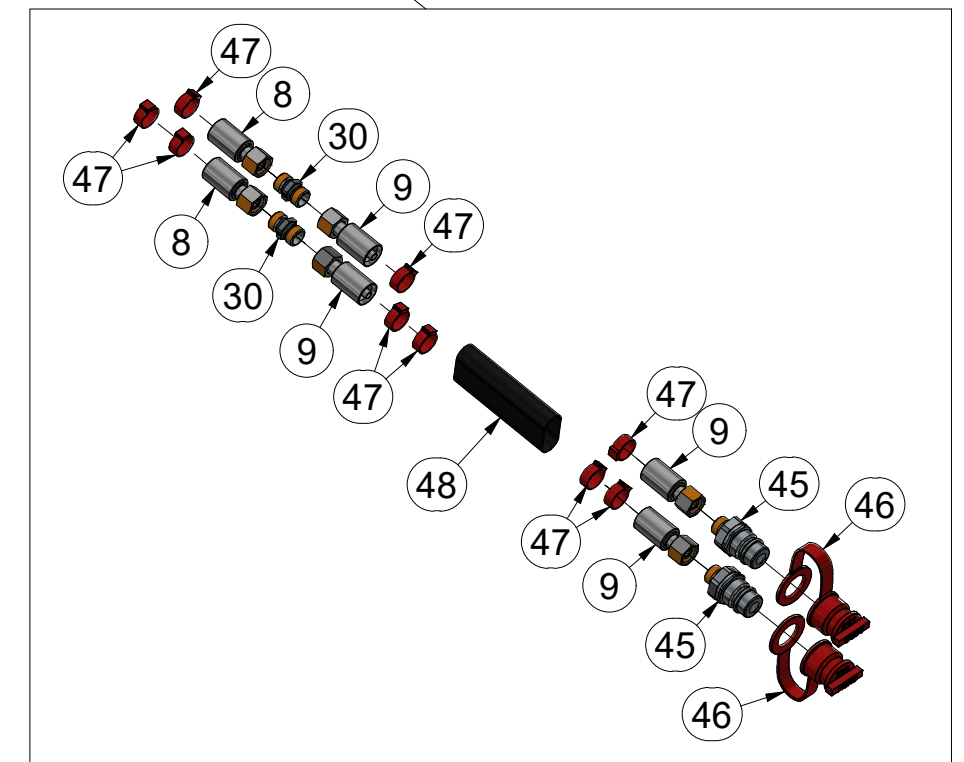
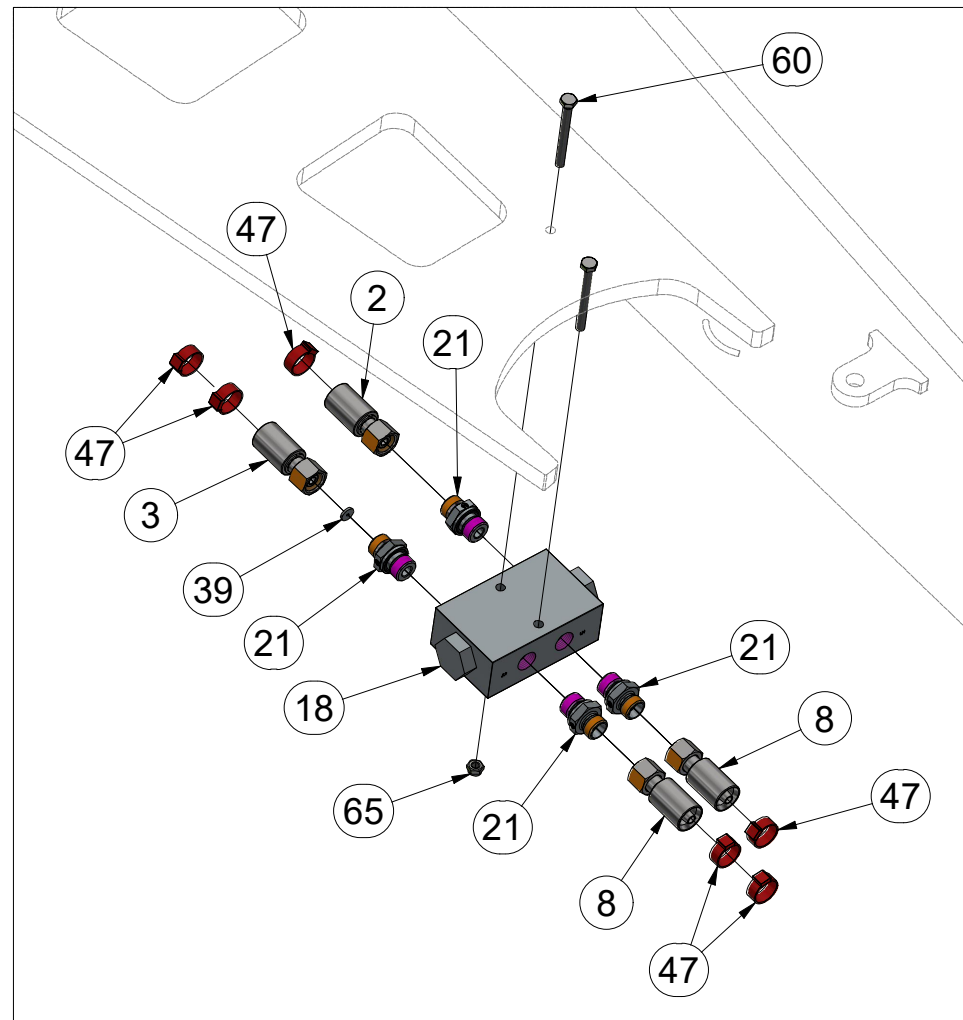
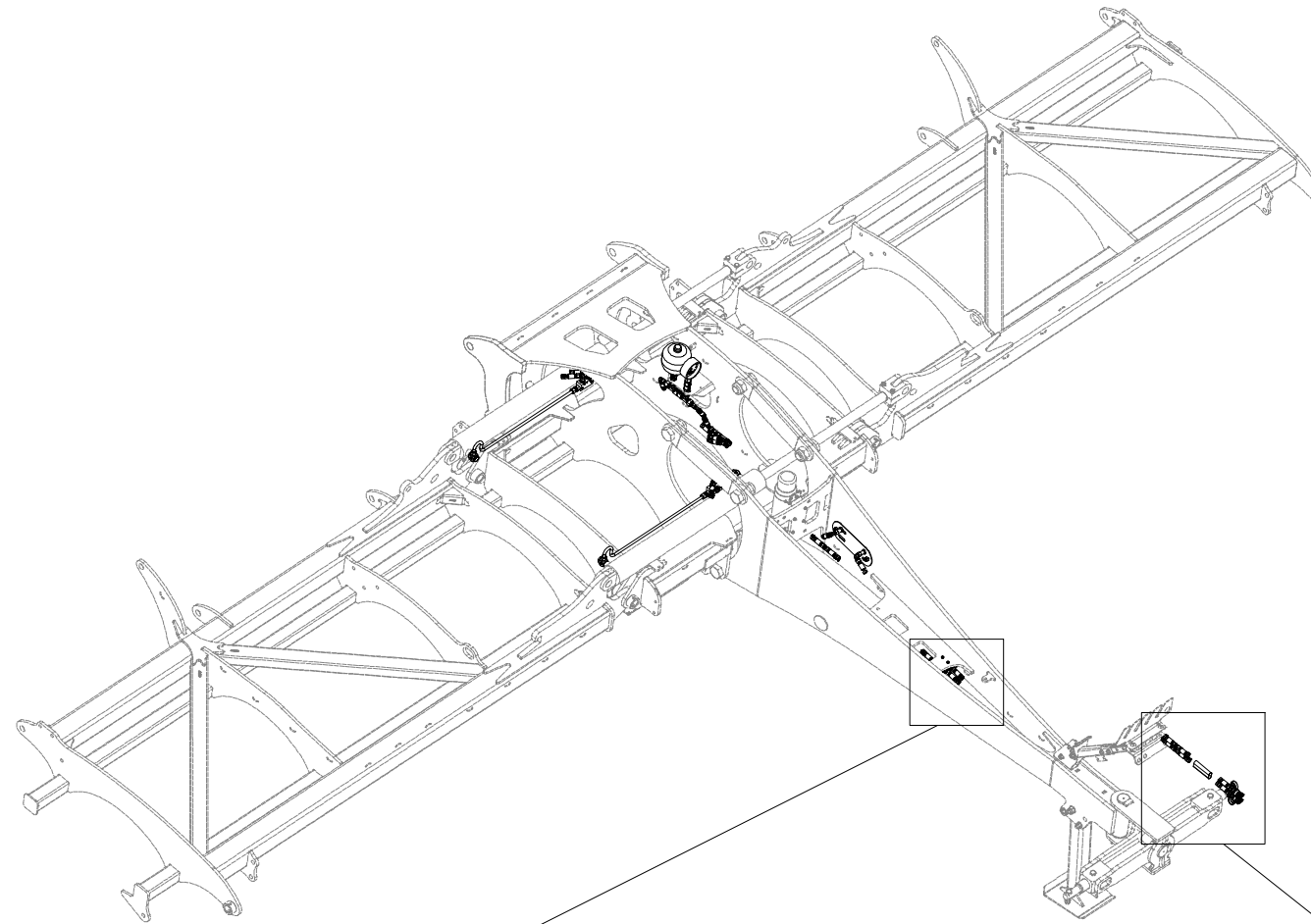

ⒸZ HYDRAULICKÝ ROZVOD SKLÁPĚNÍ

Ⓓ HYDRAULISCHE VERTEILUNG KLAPPMECHANISMUS

Ⓕ CONDUIT HYDRAULIQUE DU BASCULEMENT

ⒸB HYDRAULIC FOLDING DISTRIBUTION

ⒸU ГИДРАВЛИЧЕСКОЕ РАСПРЕДЕЛЕНИЕ СКЛАДЫВАНИЯ

ⒸL HYDRAULICZNY PRZEWÓD SKŁADANIA



VZ00017410

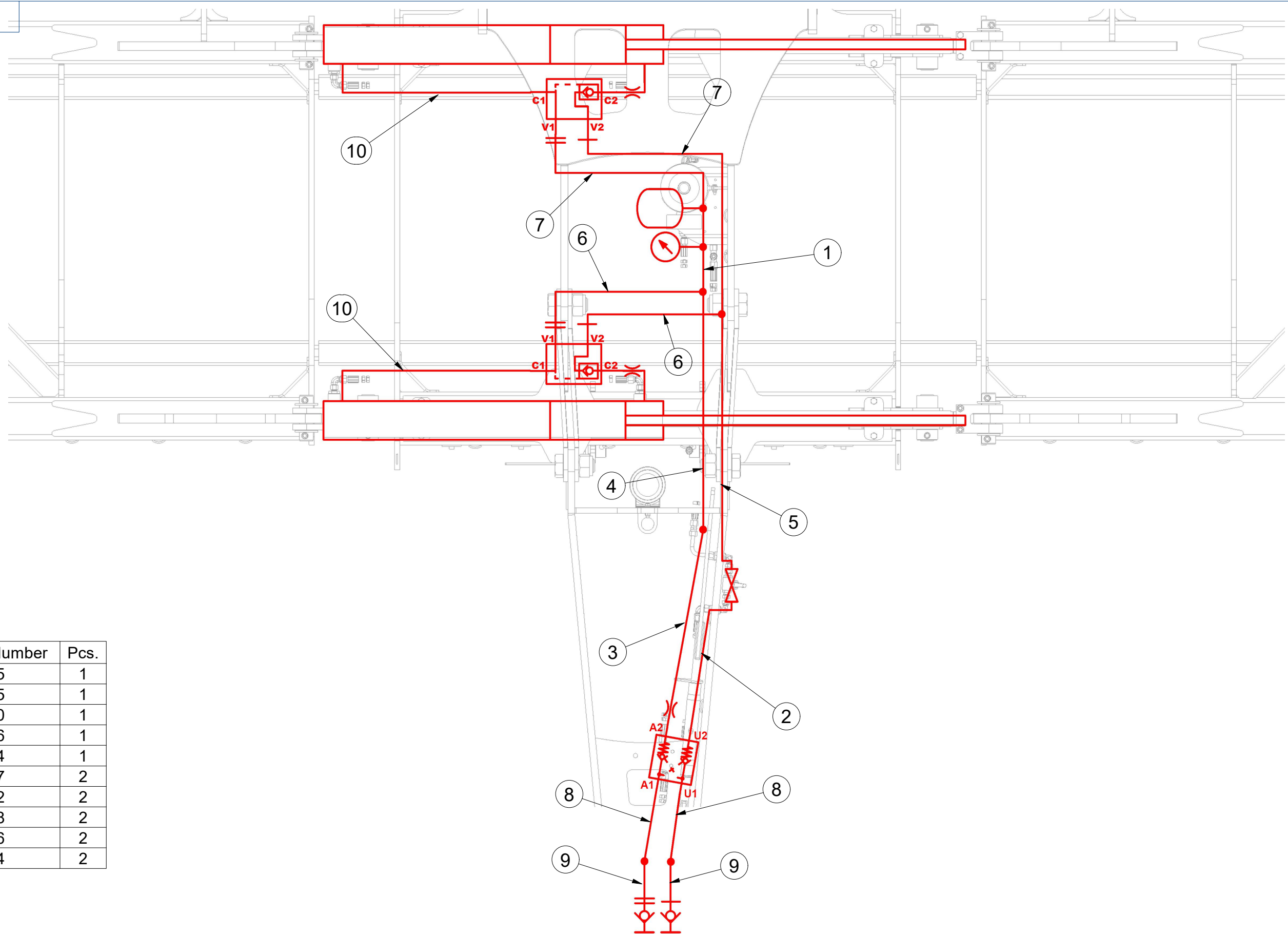

Pos.	Part Number	Pcs.
1	m18625	1
2	m07645	1
3	m20170	1
4	m07646	1
5	m07364	1
6	m07647	2
7	m03952	2
8	m07648	2
9	m11696	2
10	m16714	2

ⒸZ HYDRAULICKÝ ROZVOD SKLÁPĚNÍ

Ⓓ HYDRAULISCHE VERTEILUNG KLAPPMECHANISMUS

Ⓕ CONDUIT HYDRAULIQUE DU BASCULEMENT

ⒸGB HYDRAULIC FOLDING DISTRIBUTION

ⒸRU ГИДРАВЛИЧЕСКОЕ РАСПРЕДЕЛЕНИЕ СКЛАДЫВАНИЯ

ⒸPL HYDRAULICZNY PRZEWÓD SKŁADANIA



VZ00017410

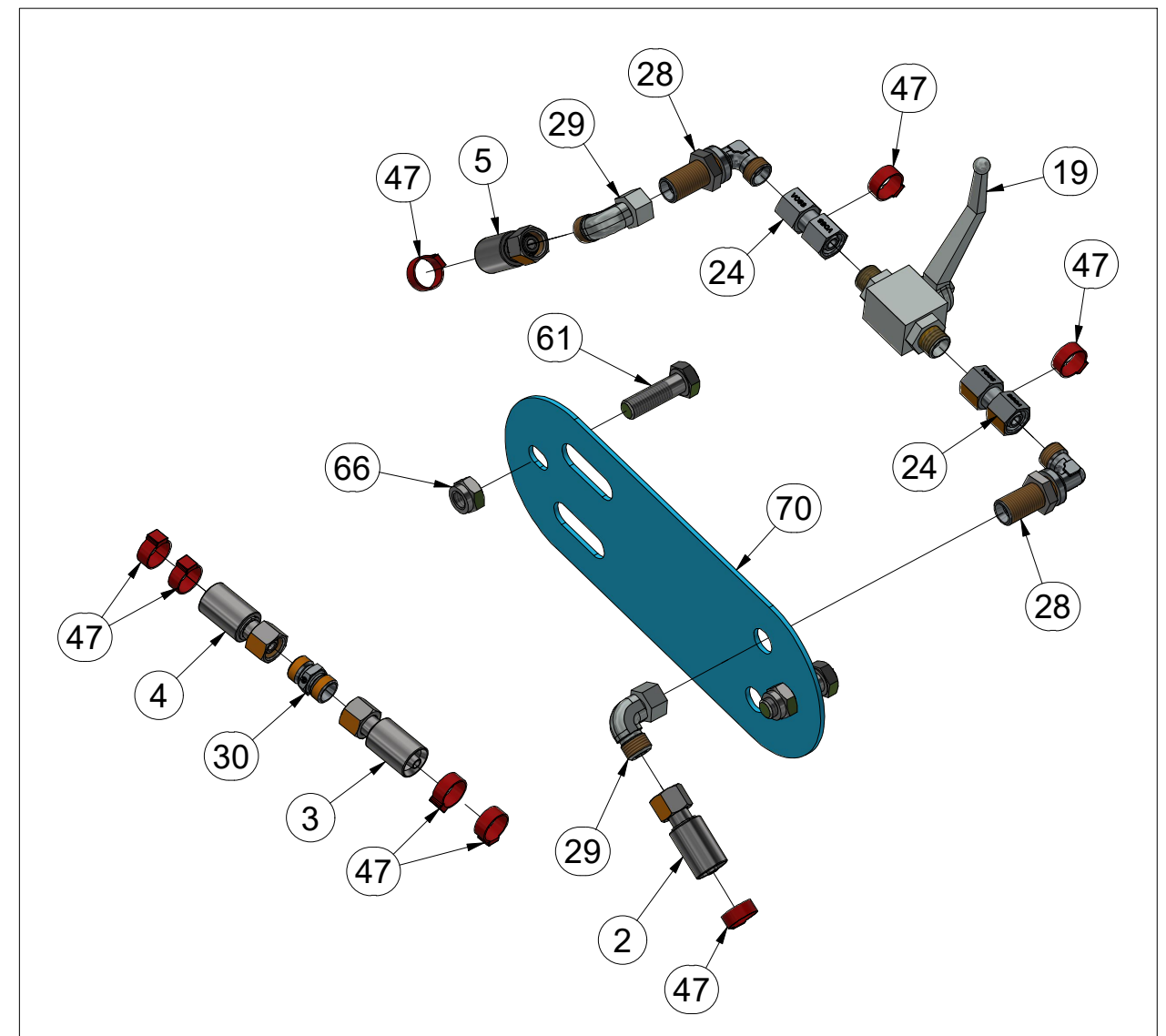
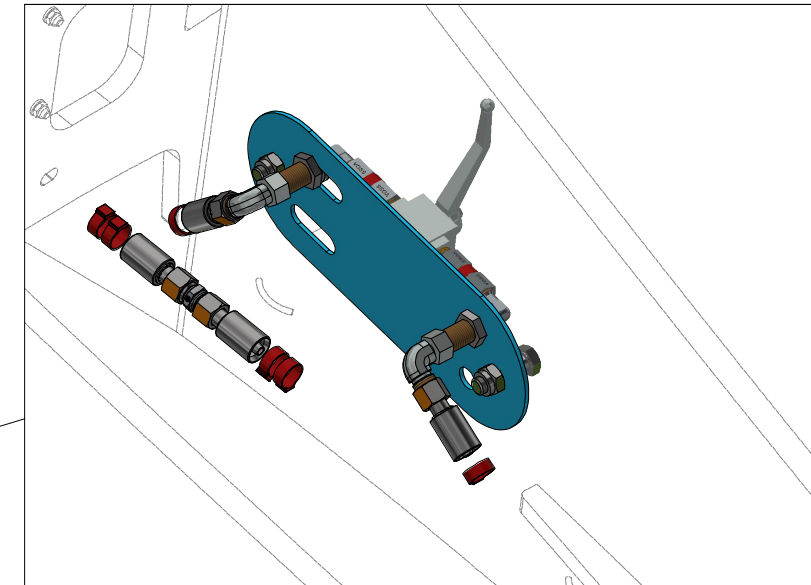
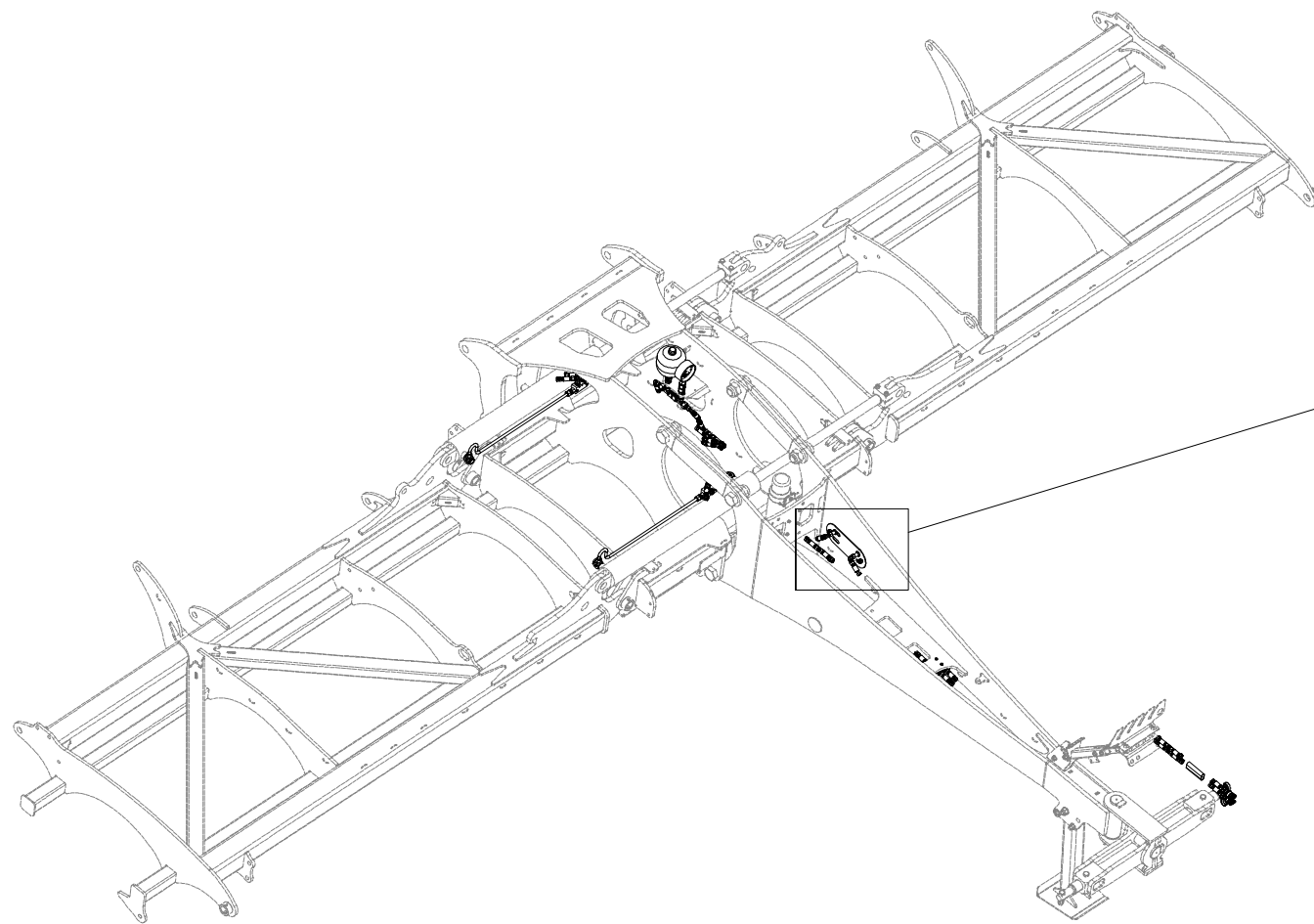

Pos.	Part Number	Pcs.	Pos.	Part Number	Pcs.
2	m07645	1	29	m06803	11
3	m20170	1	30	m03213	3
4	m07646	1	47	m11294	42
5	m07364	1	61	m03926	2
19	m04623	1	66	m04301	2
24	m22305	2	70	4025719	1
28	m08391	2			

ⒸZ HYDRAULICKÝ ROZVOD SKLÁPĚNÍ

Ⓓ HYDRAULISCHE VERTEILUNG KLAPPMECHANISMUS

Ⓕ CONDUIT HYDRAULIQUE DU BASCULEMENT

ⒸB HYDRAULIC FOLDING DISTRIBUTION

ⒸU ГИДРАВЛИЧЕСКОЕ РАСПРЕДЕЛЕНИЕ СКЛАДЫВАНИЯ

ⒸL HYDRAULICZNY PRZEWÓD SKŁADANIA

Farmet

VZ00017410

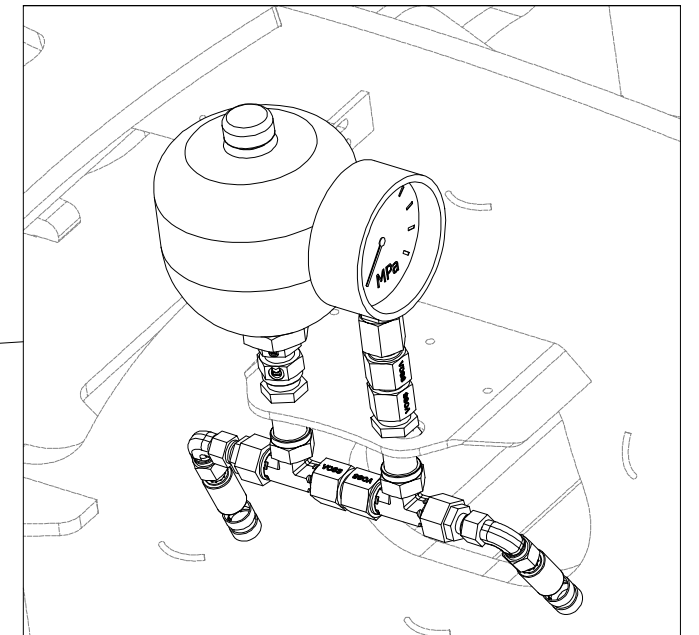
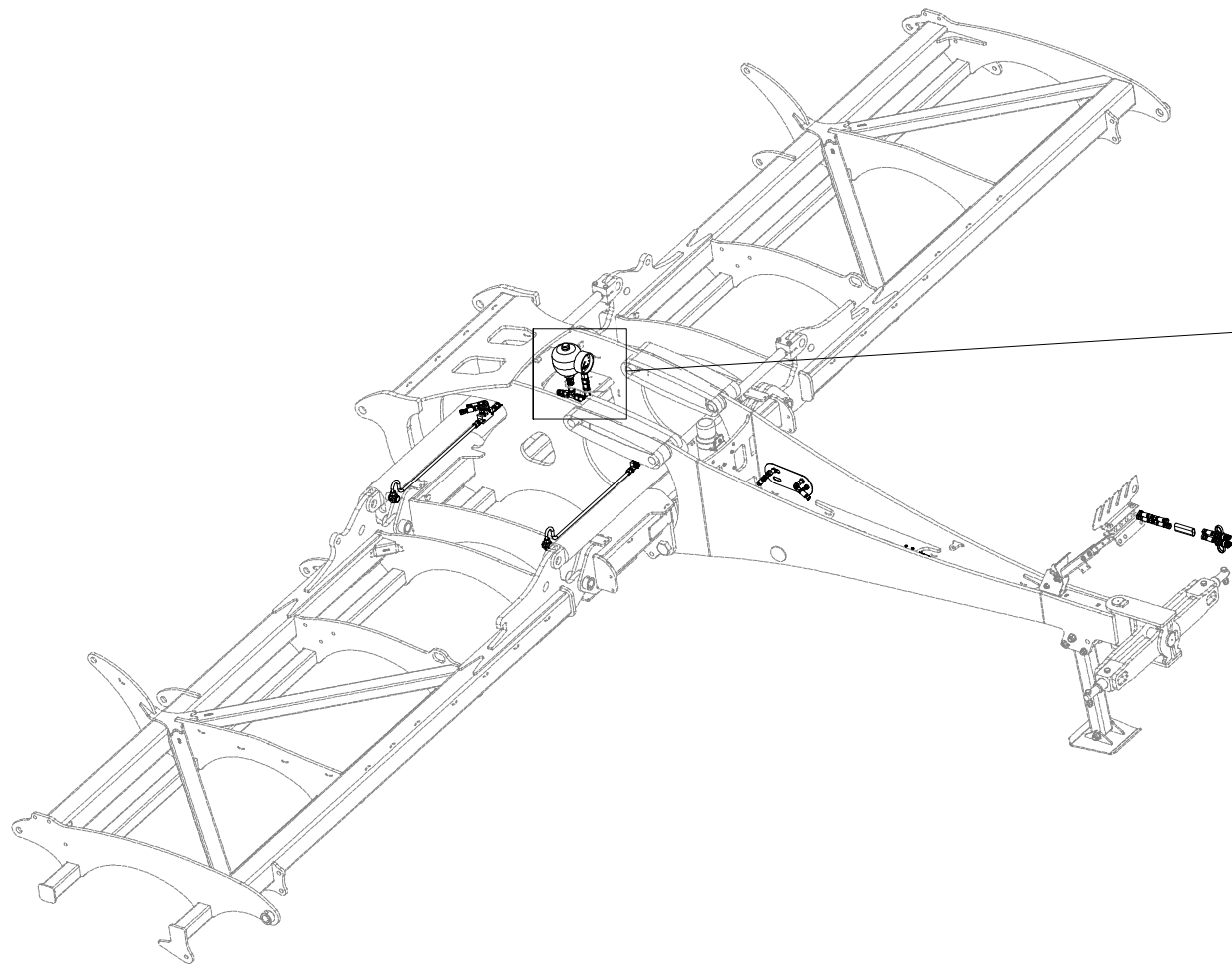

Pos.	Part Number	Pcs.	Pos.	Part Number	Pcs.
1	m18625	1	27	m08533	2
7	m03952	2	29	m06803	11
13	m11974	1	31	m09625	2
15	m09910	1	33	m06879	2
16	m05518	1	38	m04320	1
22	m07993	1	47	m11294	42
25	m22307	2			

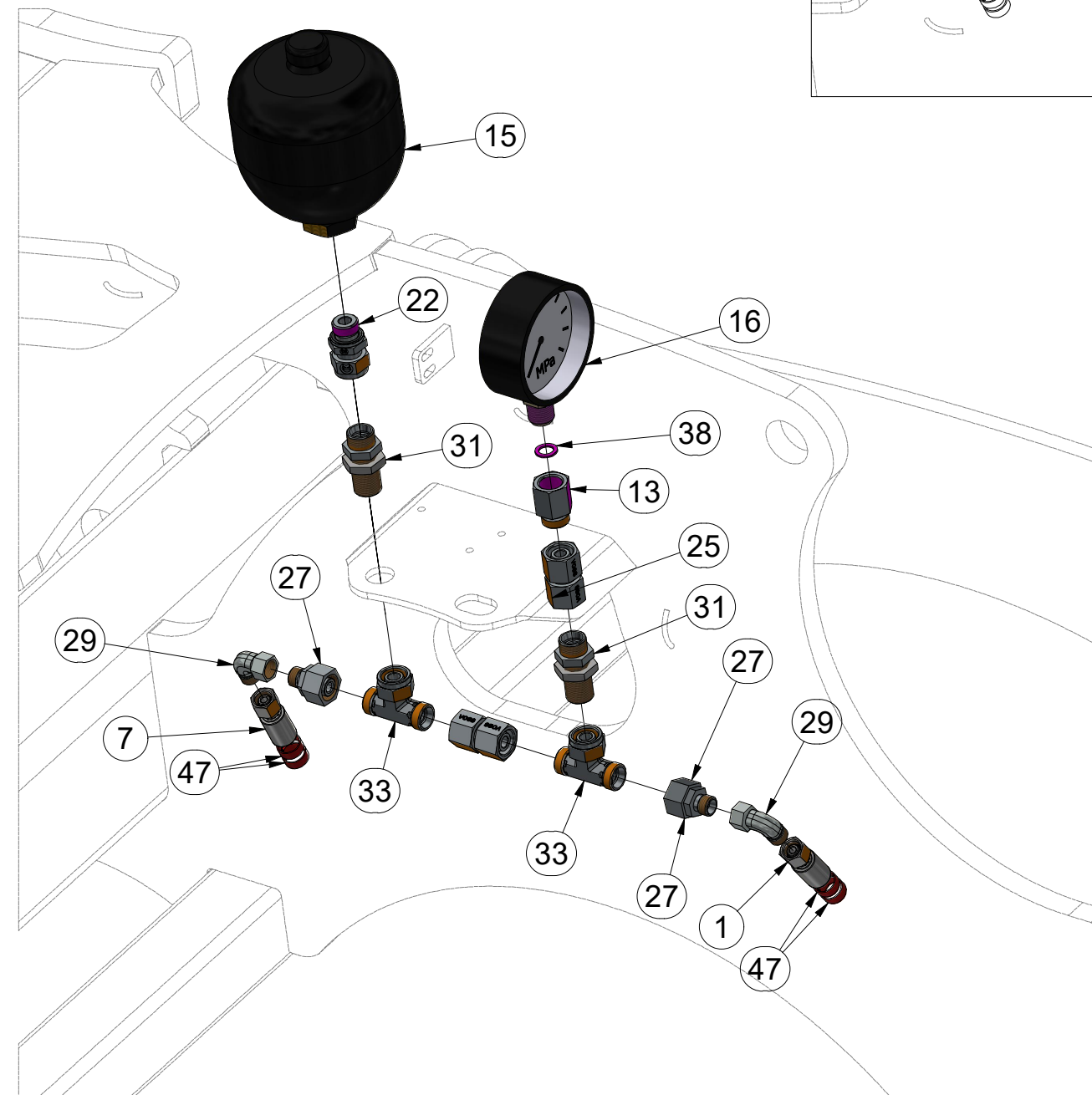

ⒸZ HYDRAULICKÝ ROZVOD SKLÁPĚNÍ

Ⓓ HYDRAULISCHE VERTEILUNG KLAPPMECHANISMUS

Ⓕ CONDUIT HYDRAULIQUE DU BASCULEMENT

ⒸGB HYDRAULIC FOLDING DISTRIBUTION

ⒸRU ГИДРАВЛИЧЕСКОЕ РАСПРЕДЕЛЕНИЕ СКЛАДЫВАНИЯ

ⒸPL HYDRAULICZNY PRZEWÓD SKŁADANIA



VZ00017410

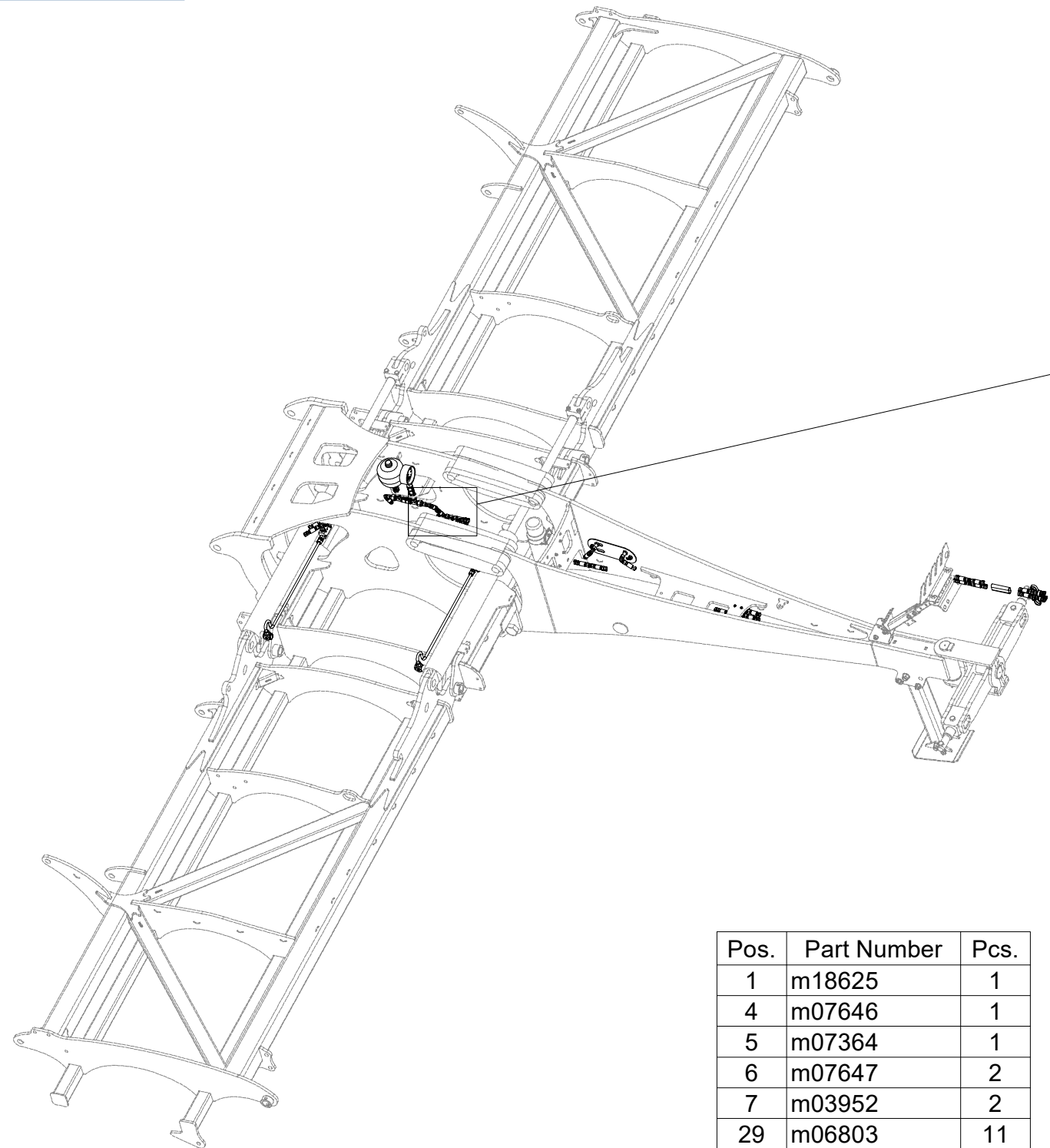

Pos.	Part Number	Pcs.
1	m18625	1
4	m07646	1
5	m07364	1
6	m07647	2
7	m03952	2
29	m06803	11
32	m03889	2
47	m11294	42

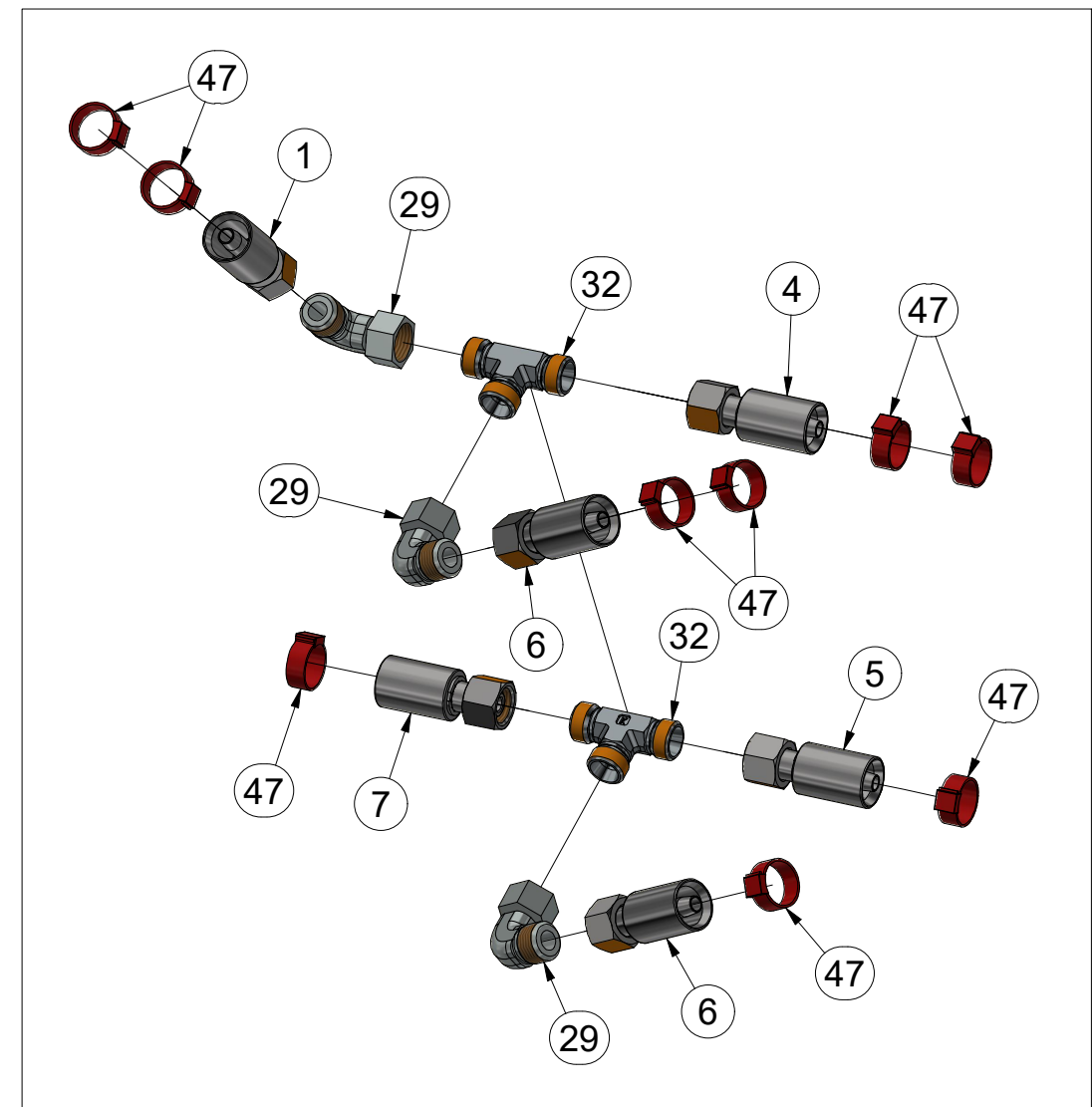
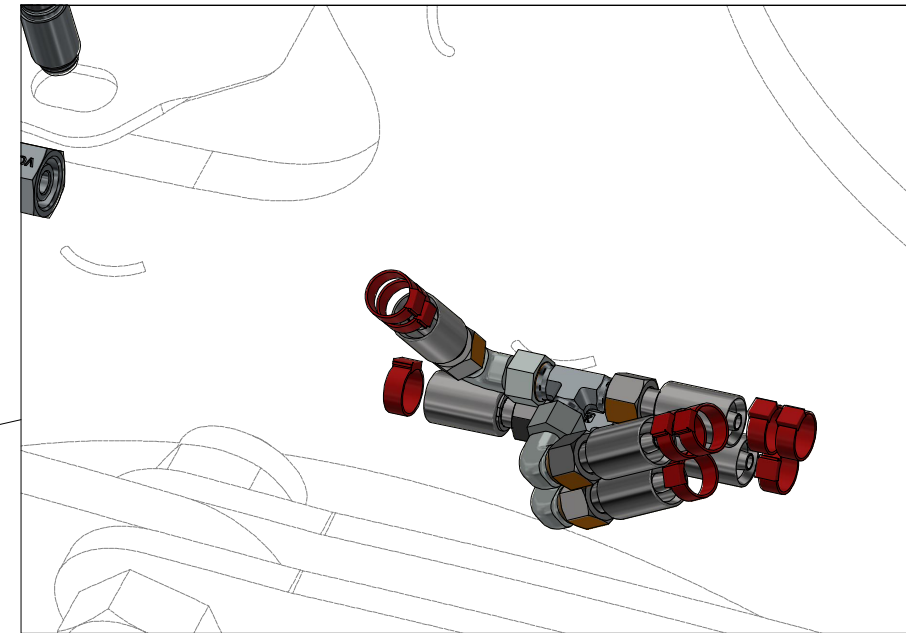

ⒸZ HYDRAULICKÝ ROZVOD SKLÁPĚNÍ

Ⓓ HYDRAULISCHE VERTEILUNG KLAPPMECHANISMUS

Ⓕ CONDUIT HYDRAULIQUE DU BASCULEMENT

ⒼB HYDRAULIC FOLDING DISTRIBUTION

Ⓔ RU ГИДРАВЛИЧЕСКОЕ РАСПРЕДЕЛЕНИЕ СКЛАДЫВАНИЯ

Ⓖ PL HYDRAULICZNY PRZEWÓD SKŁADANIA

Farmet

VZ00017410

Pos.	Part Number	Pcs.	Pos.	Part Number	Pcs.
6	m07647	2	26	m22306	2
10	m16714	2	29	m06803	11
17	m11103	2	35	m17321	4
20	m20912	4	40	m10774	2
21	m06528	8	47	m11294	42
23	m06320	4			

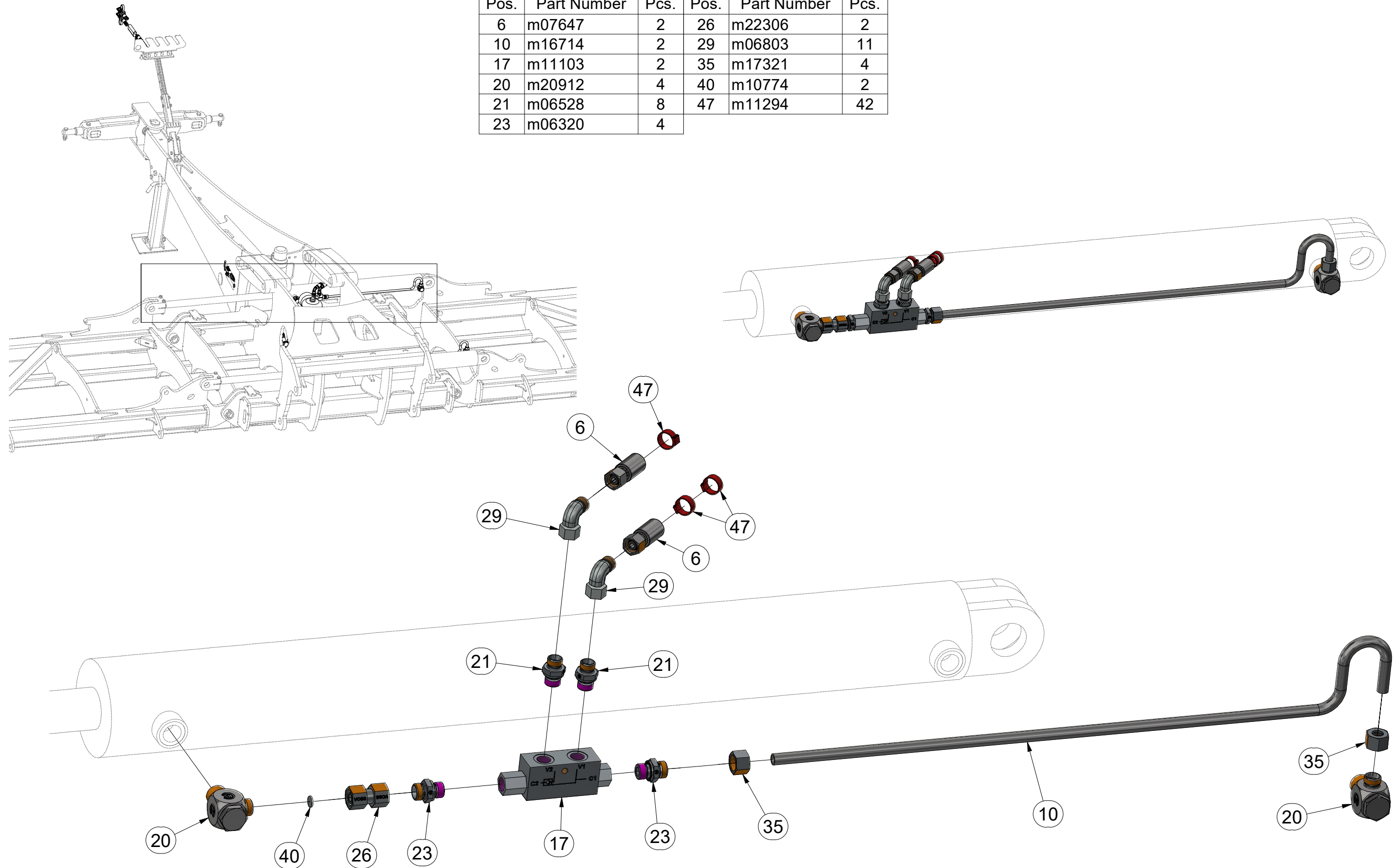

ⒸZ HYDRAULICKÝ ROZVOD SKLÁPĚNÍ

Ⓓ HYDRAULISCHE VERTEILUNG KLAPPMECHANISMUS

Ⓕ CONDUIT HYDRAULIQUE DU BASCULEMENT

ⒼB HYDRAULIC FOLDING DISTRIBUTION

Ⓔ RU ГИДРАВЛИЧЕСКОЕ РАСПРЕДЕЛЕНИЕ СКЛАДЫВАНИЯ

Ⓖ PL HYDRAULICZNY PRZEWÓD SKŁADANIA

Farmet

VZ00017410

Pos.	Part Number	Pcs.	Pos.	Part Number	Pcs.
7	m03952	2	26	m22306	2
10	m16714	2	29	m06803	11
17	m11103	2	35	m17321	4
20	m20912	4	40	m10774	2
21	m06528	8	47	m11294	42
23	m06320	4			

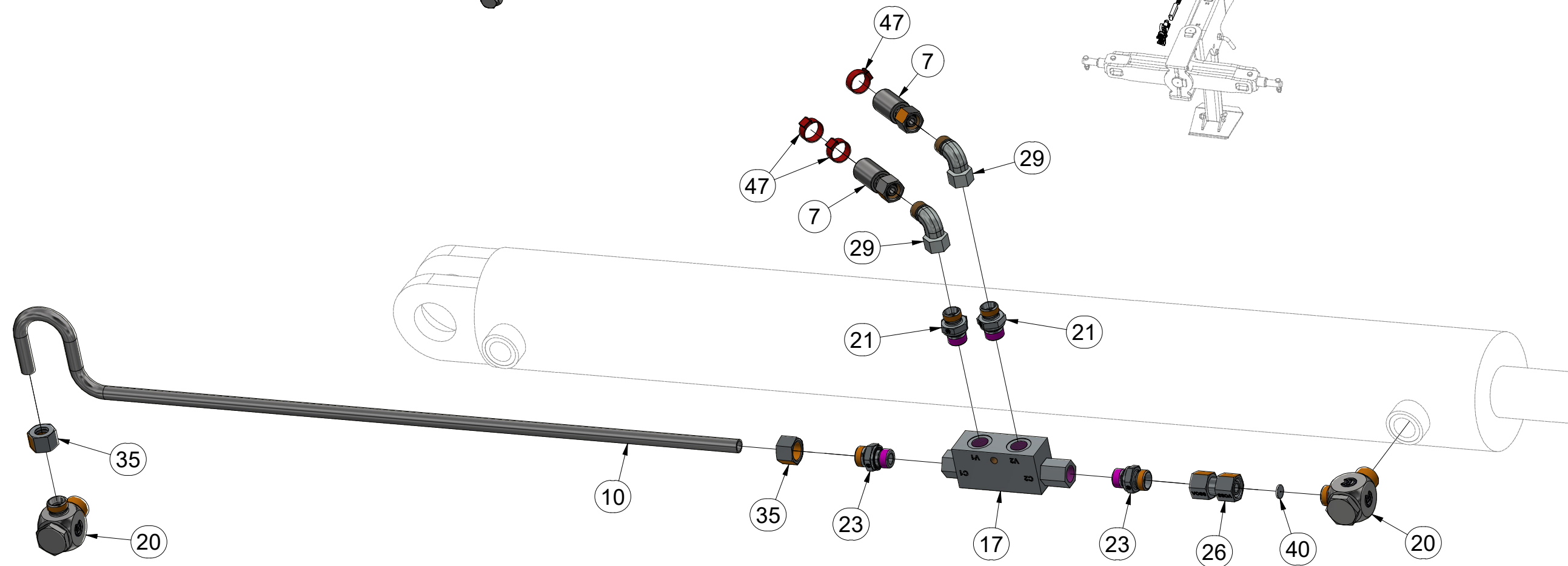
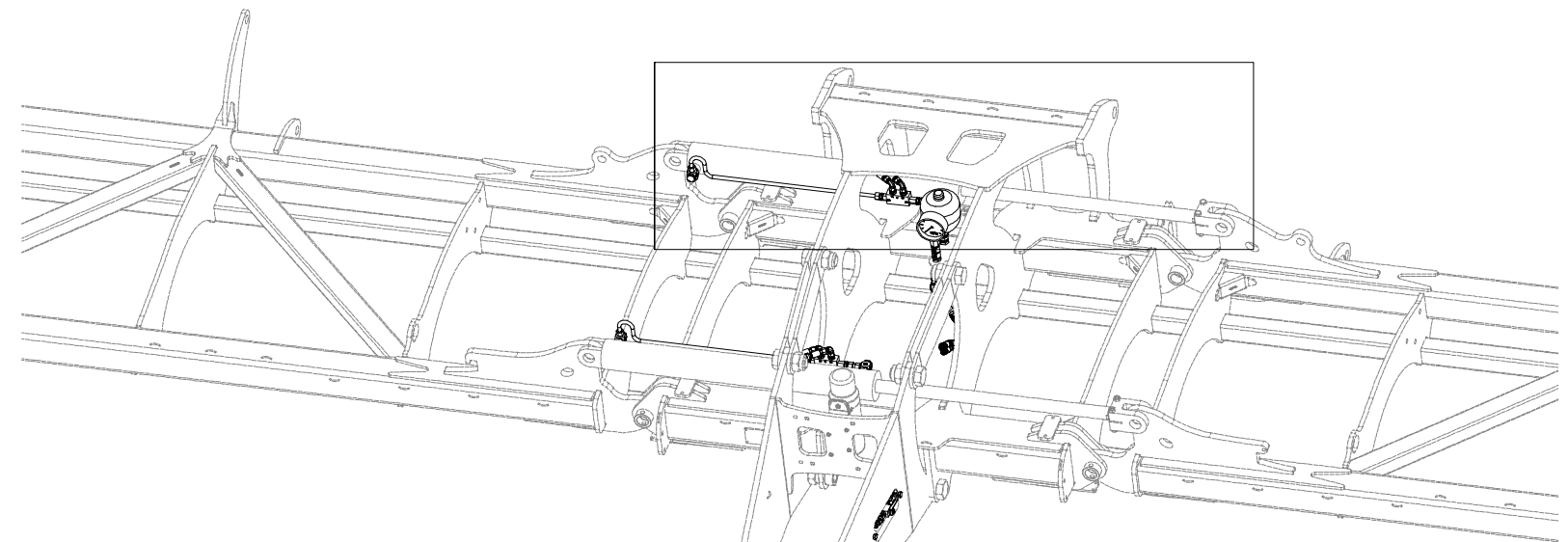
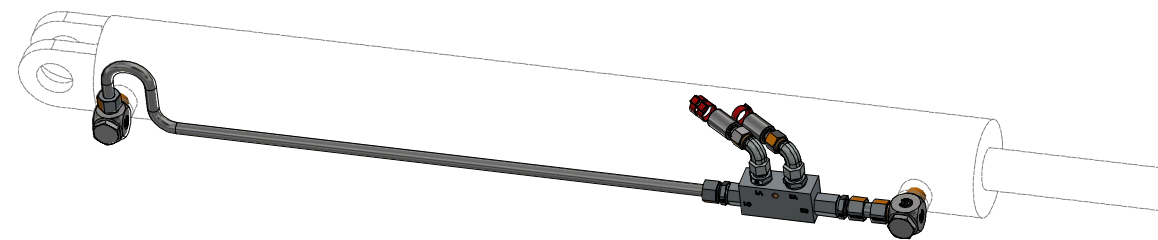

ⒸZ HYDRAULICKÝ ROZVOD - ZAHLUBOVÁNÍ

Ⓓ HYDRAULISCHE VERTEILUNG - EINSENKUNG

Ⓕ CONDUIT HYDRAULIQUE - L'ENFONCEMENT

ⒸB HYDRAULIC DISTRIBUTION - RECESSING

ⒸU ГИДРАВЛИЧЕСКОЕ РАСПРЕДЕЛЕНИЕ - ЗАГЛУБЛЕНИЕ

ⒸL HYDRAULICZNY PRZEWÓD - ZAGŁĘBIENIA

Farmet

VZ00017544

Pos.	Part Number	Pcs.
43	m11183	3

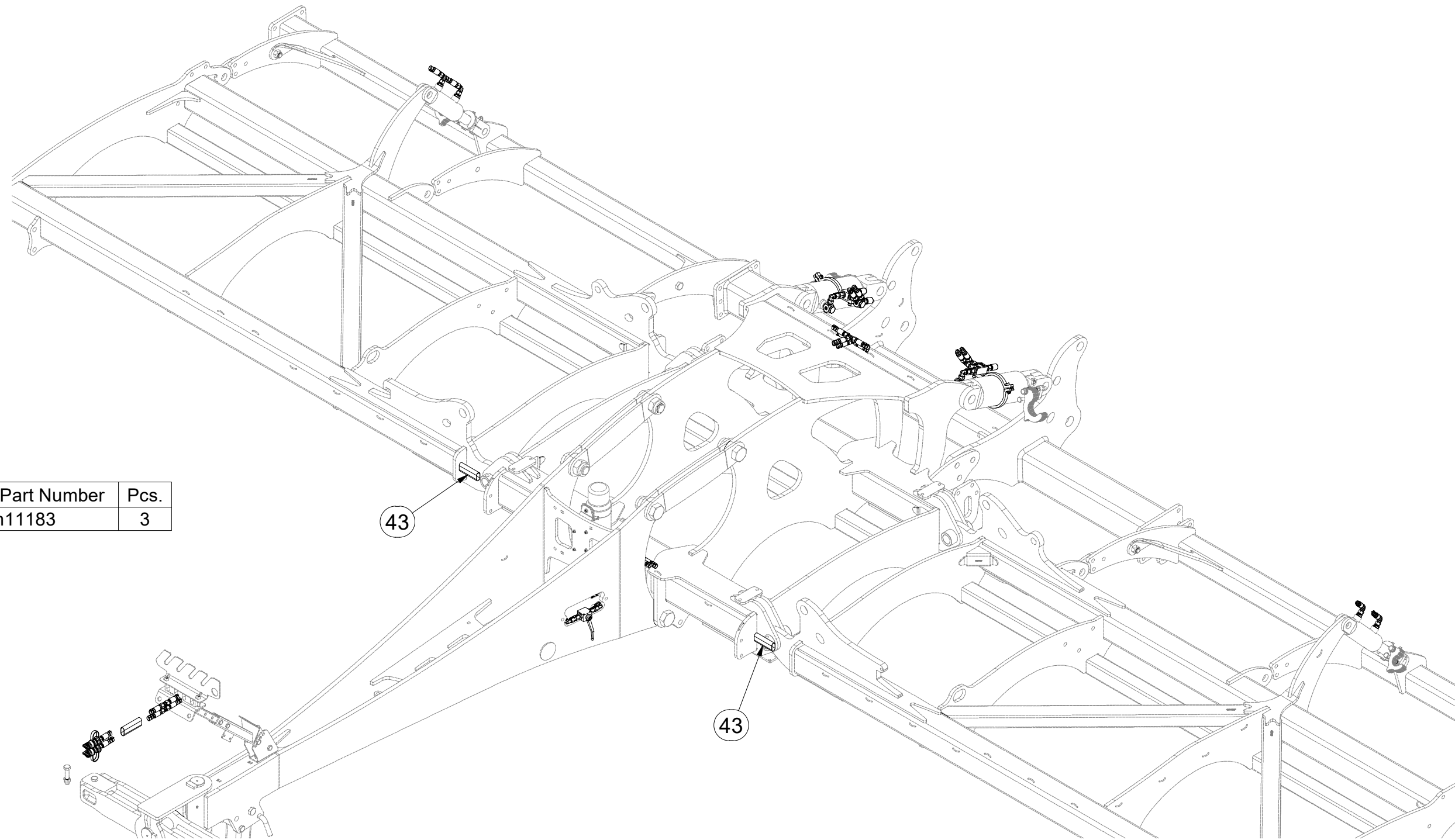

ⒸZ HYDRAULICKÝ ROZVOD - ZAHLUBOVÁNÍ

Ⓓ HYDRAULISCHE VERTEILUNG - EINSENKUNG

Ⓕ CONDUIT HYDRAULIQUE - L'ENFONCEMENT

ⒸB HYDRAULIC DISTRIBUTION - RECESSING

ⒸU ГИДРАВЛИЧЕСКОЕ РАСПРЕДЕЛЕНИЕ - ЗАГЛУБЛЕНИЕ

ⒸL HYDRAULICZNY PRZEWÓD - ZAGŁĘBIENIA



VZ00017544

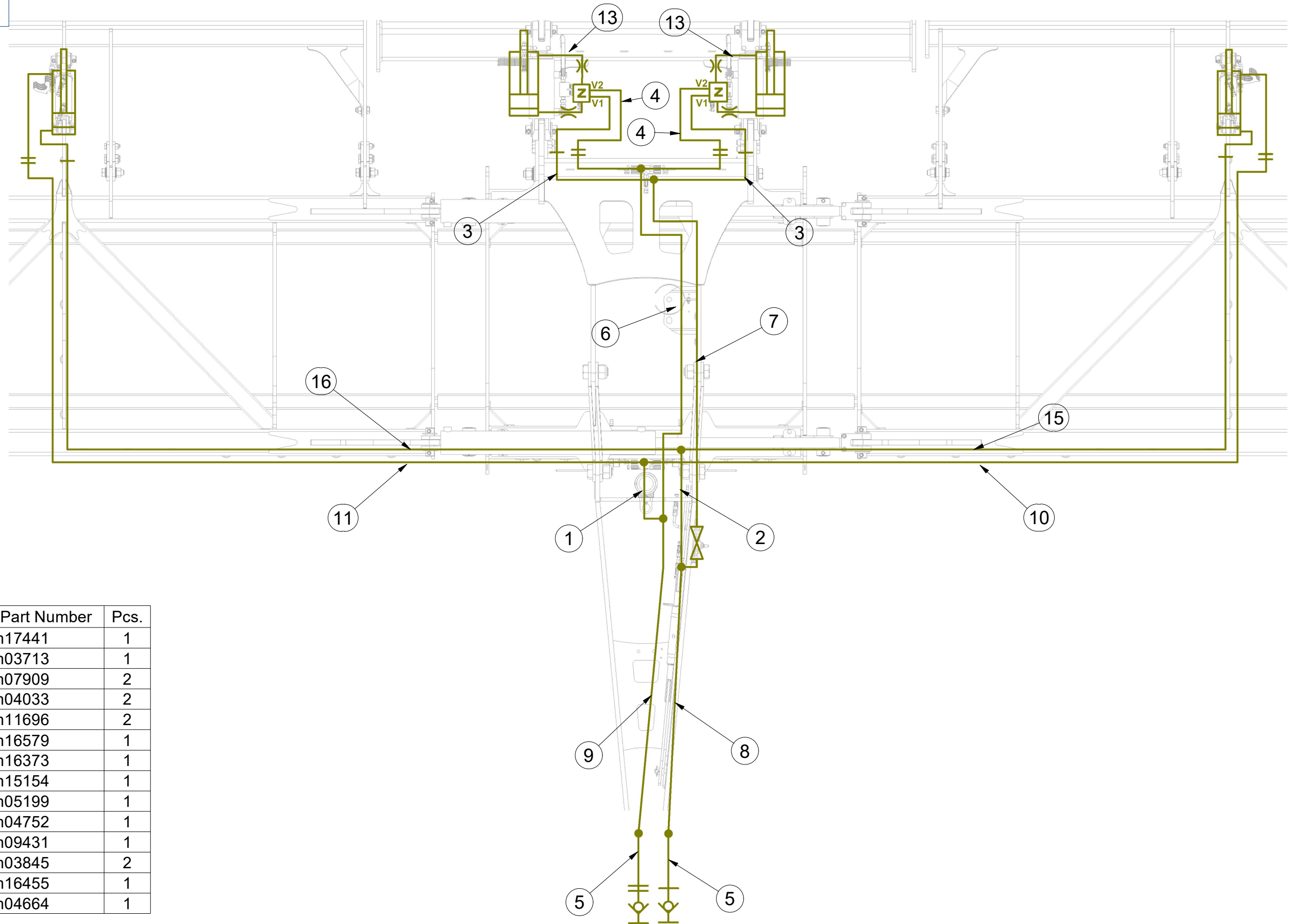

Pos.	Part Number	Pcs.
1	m17441	1
2	m03713	1
3	m07909	2
4	m04033	2
5	m11696	2
6	m16579	1
7	m16373	1
8	m15154	1
9	m05199	1
10	m04752	1
11	m09431	1
13	m03845	2
15	m16455	1
16	m04664	1

ⒸZ HYDRAULICKÝ ROZVOD - ZAHLUBOVÁNÍ

Ⓓ HYDRAULISCHE VERTEILUNG - EINSENKUNG

Ⓕ CONDUIT HYDRAULIQUE - L'ENFONCEMENT

ⒸB HYDRAULIC DISTRIBUTION - RECESSING

ⒸU ГИДРАВЛИЧЕСКОЕ РАСПРЕДЕЛЕНИЕ - ЗАГЛУБЛЕНИЕ

ⒸL HYDRAULICZNY PRZEWÓD - ZAGŁĘBIENIA



VZ00017544

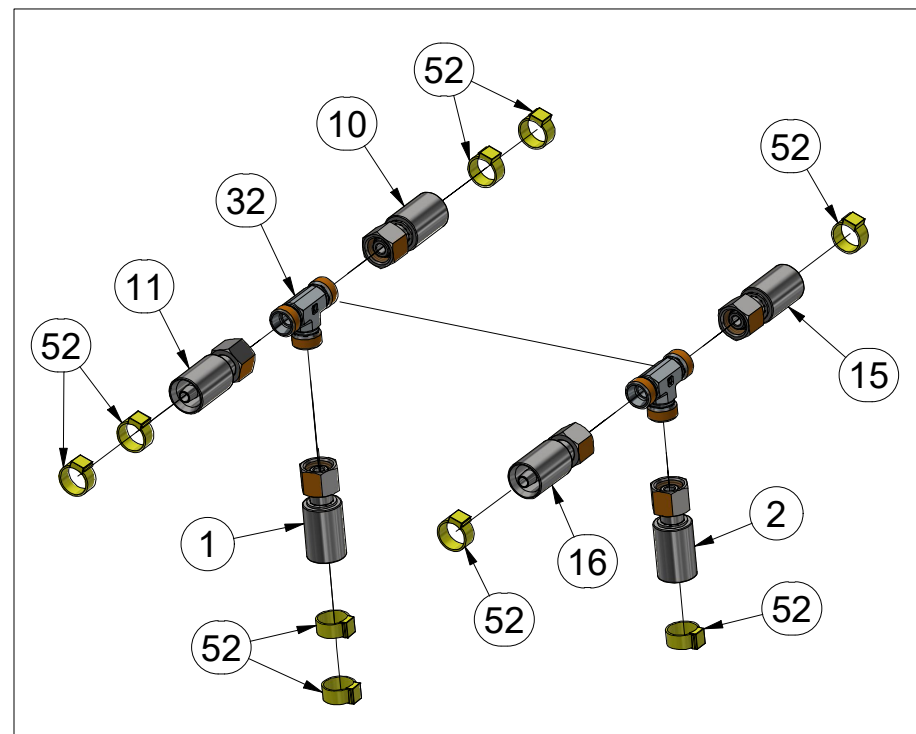
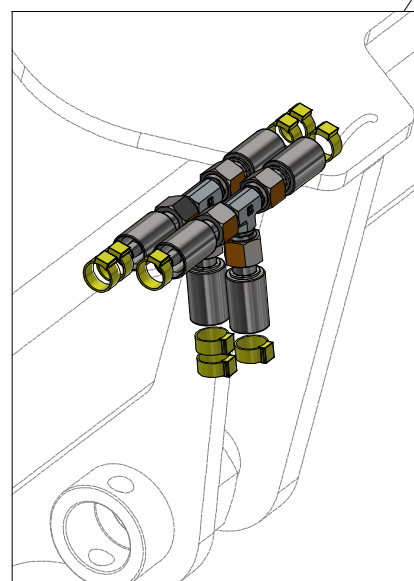
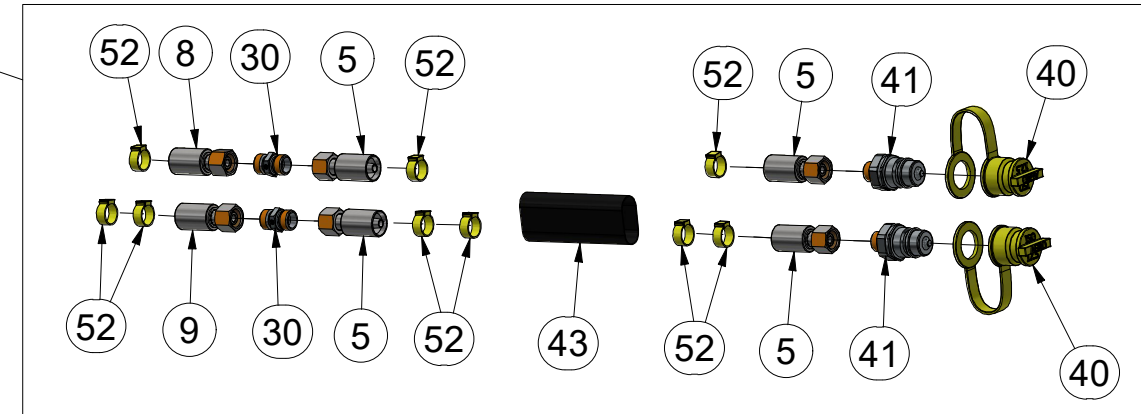
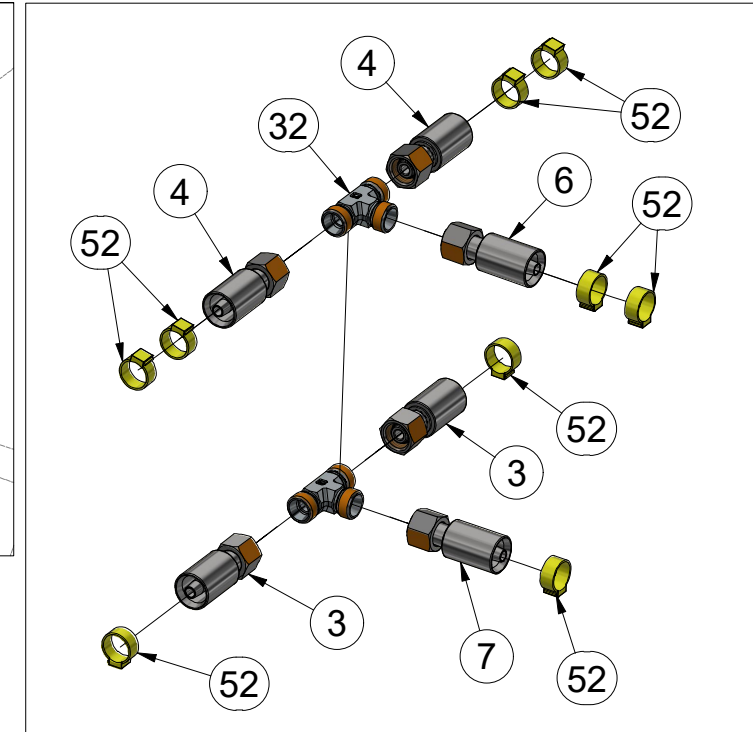
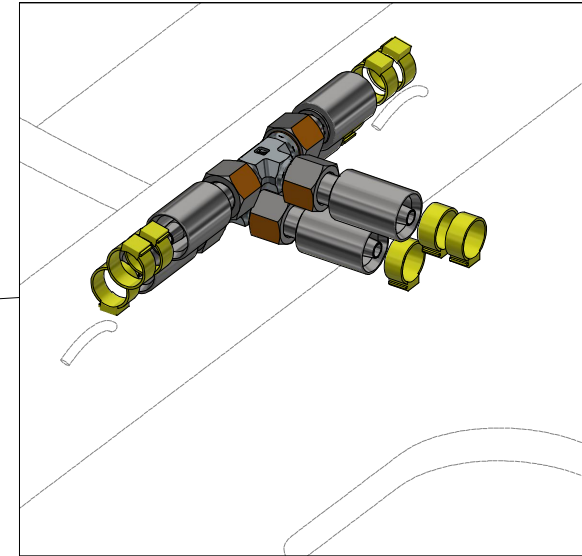
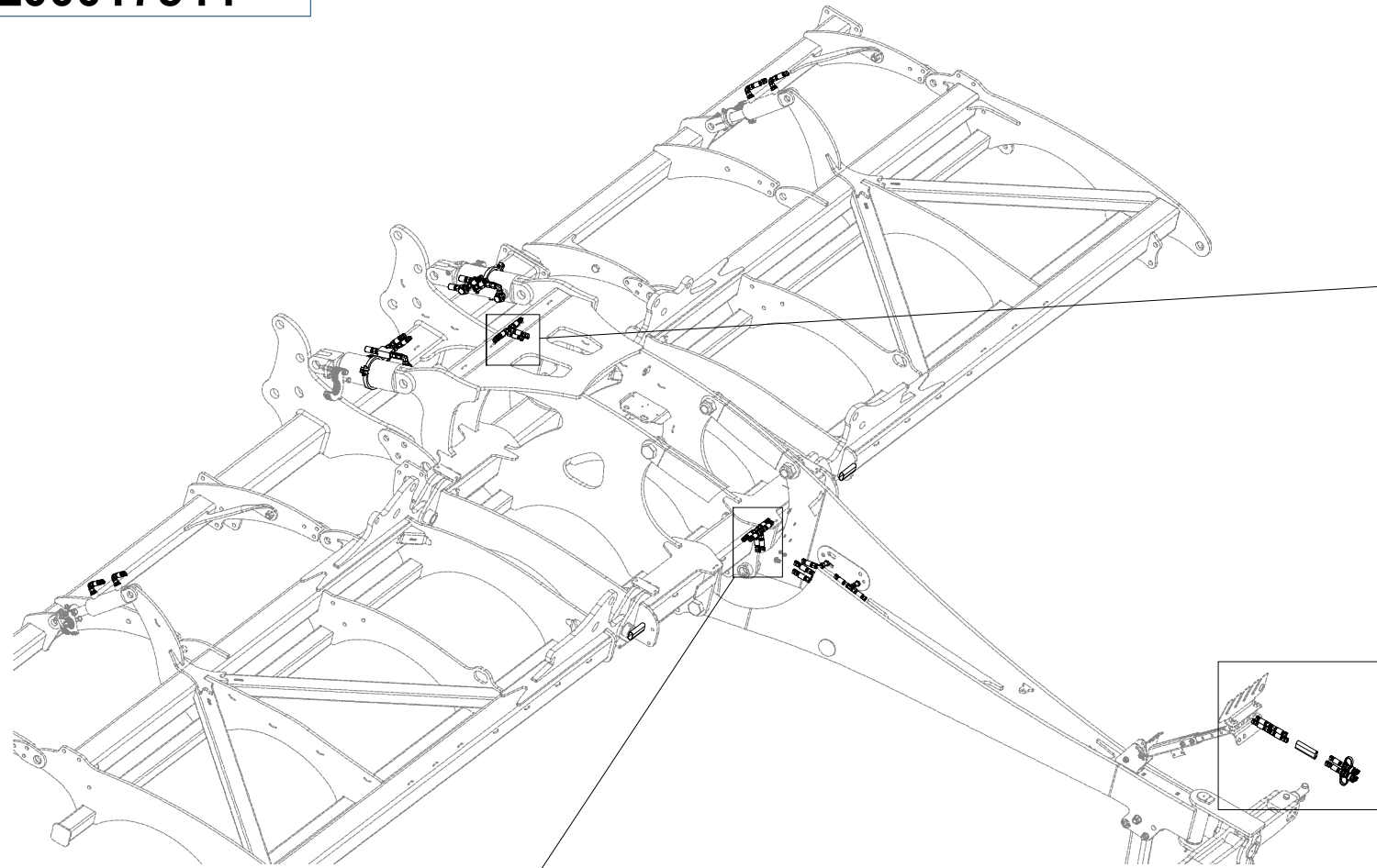

Pos.	Part Number	Pcs.	Pos.	Part Number	Pcs.
1	m17441	1	11	m09431	1
2	m03713	1	15	m16455	1
3	m07909	2	16	m04664	1
4	m04033	2	30	m03213	2
5	m11696	2	32	m03889	5
6	m16579	1	40	m04023	2
7	m16373	1	41	m03849	2
8	m15154	1	43	m11183	3
9	m05199	1	52	m11289	50
10	m04752	1			

ⒸZ HYDRAULICKÝ ROZVOD - ZAHLUBOVÁNÍ

Ⓓ HYDRAULISCHE VERTEILUNG - EINSENKUNG

Ⓕ CONDUIT HYDRAULIQUE - L'ENFONCEMENT

ⒸB HYDRAULIC DISTRIBUTION - RECESSING

ⒸU ГИДРАВЛИЧЕСКОЕ РАСПРЕДЕЛЕНИЕ - ЗАГЛУБЛЕНИЕ

ⒸL HYDRAULICZNY PRZEWÓD - ZAGŁĘBIENIA



VZ00017544

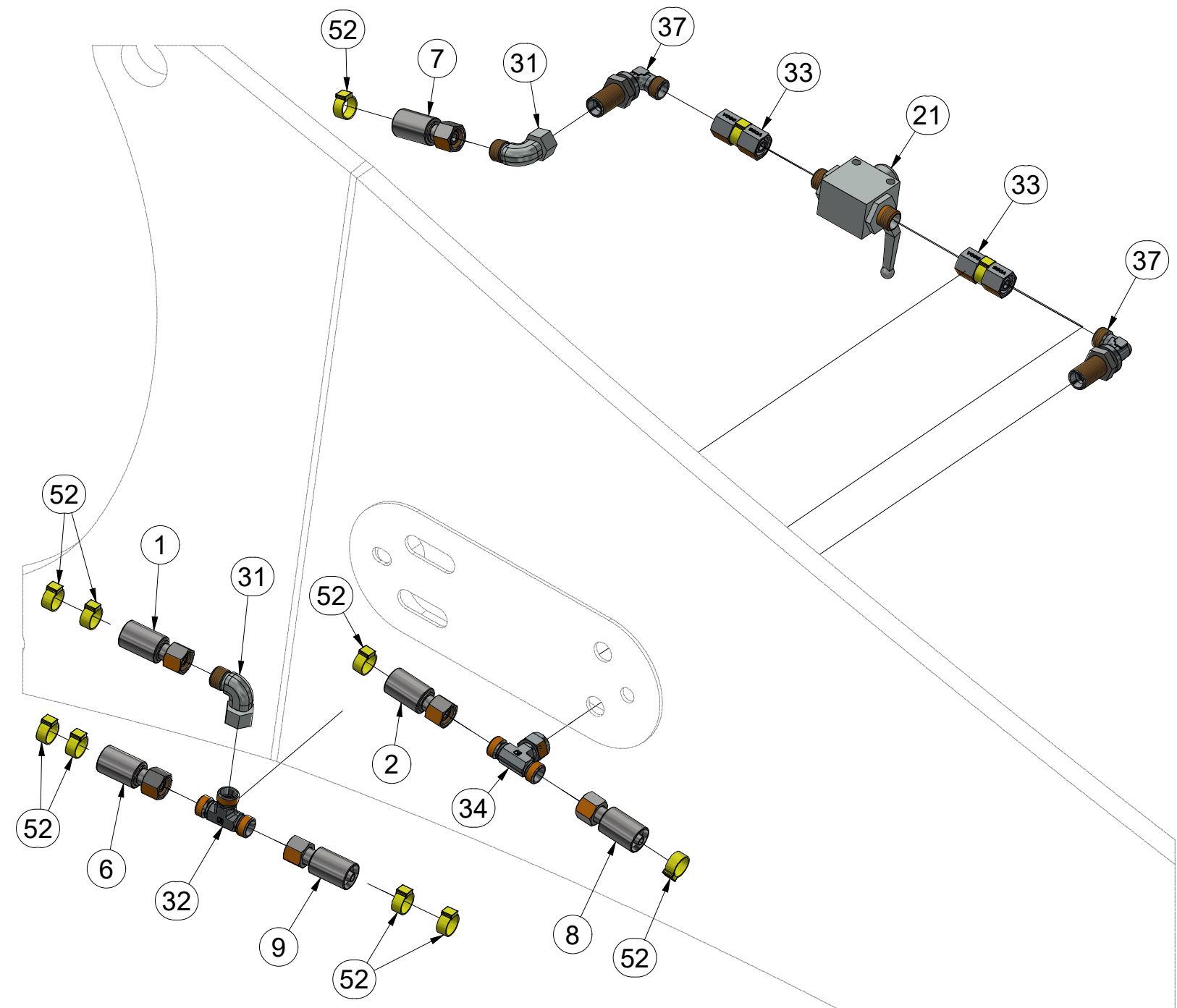
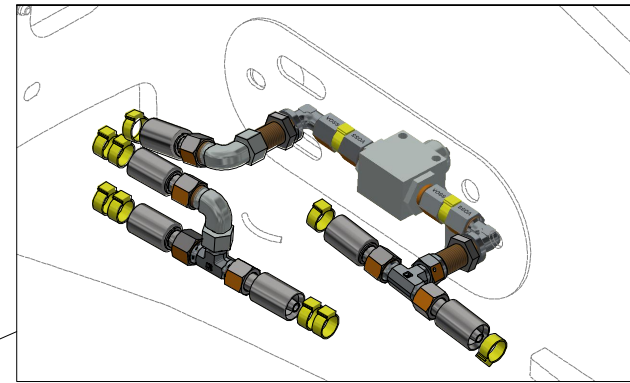
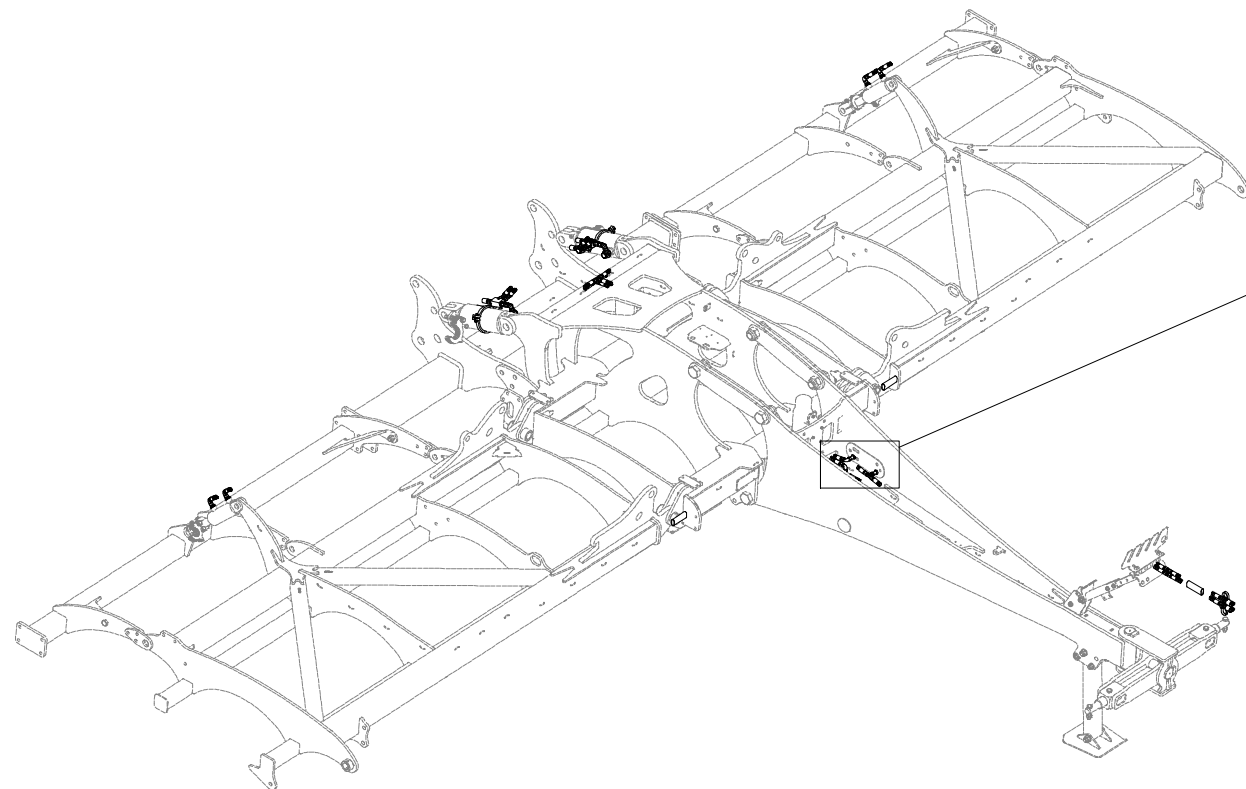

Pos.	Part Number	Pcs.
1	m17441	1
2	m03713	1
6	m16579	1
7	m16373	1
8	m15154	1
9	m05199	1
21	m04623	1
31	m06803	10
32	m03889	5
33	m22305	2
34	m07567	1
37	m08391	2
52	m11289	50

ⒸZ HYDRAULICKÝ ROZVOD - ZAHLUBOVÁNÍ

Ⓓ HYDRAULISCHE VERTEILUNG - EINSENKUNG

Ⓕ CONDUIT HYDRAULIQUE - L'ENFONCEMENT

ⒸB HYDRAULIC DISTRIBUTION - RECESSING

ⒸU ГИДРАВЛИЧЕСКОЕ РАСПРЕДЕЛЕНИЕ - ЗАГЛУБЛЕНИЕ

ⒸL HYDRAULICZNY PRZEWÓD - ZAGŁĘBIENIA



VZ00017544

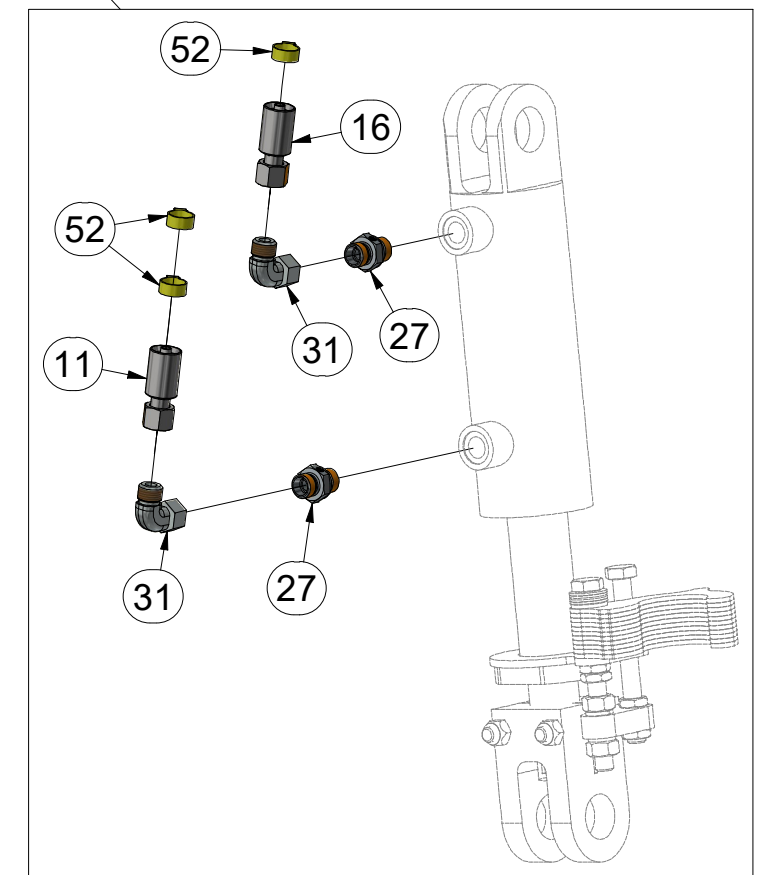
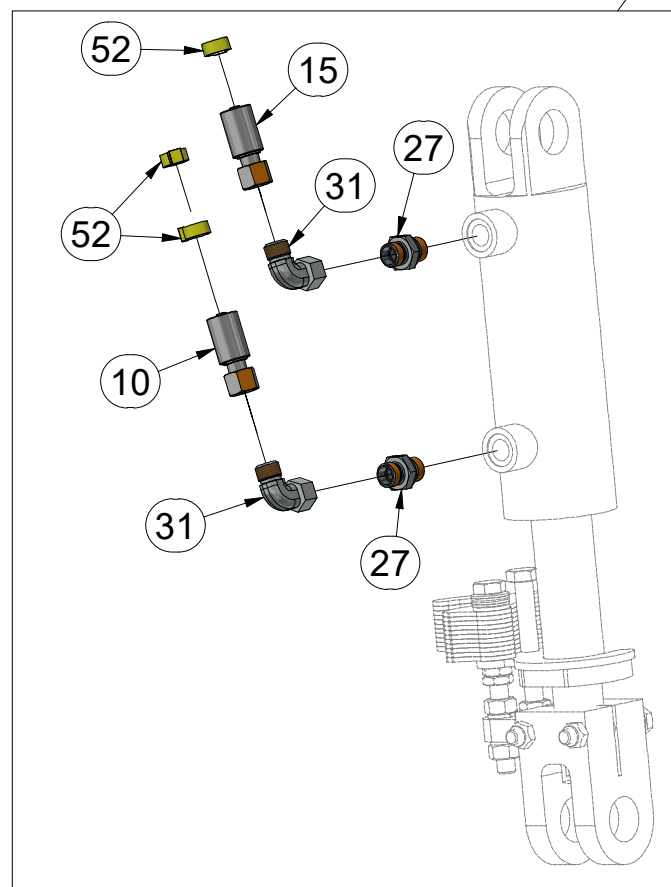
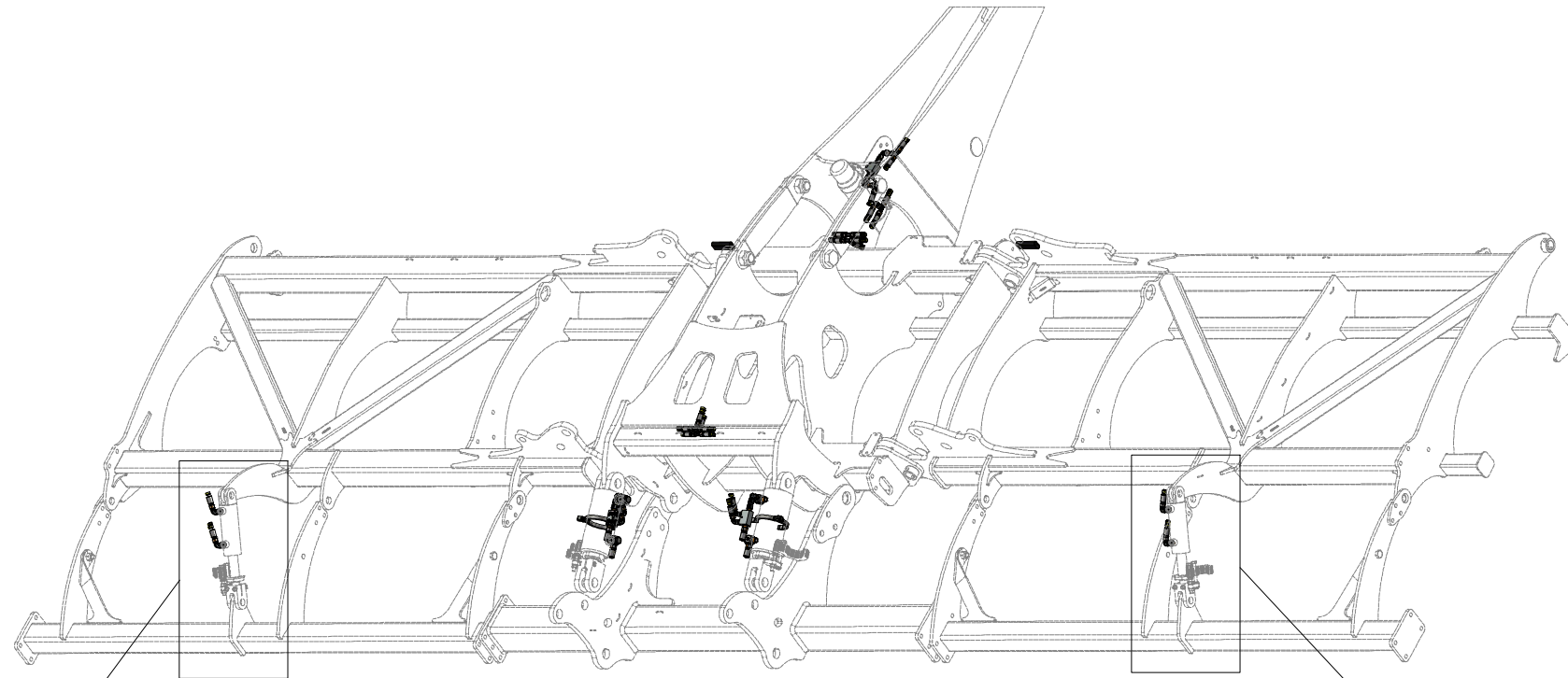

Pos.	Part Number	Pcs.
10	m04752	1
11	m09431	1
15	m16455	1
16	m04664	1
27	m07906	4
31	m06803	10
52	m11289	50

ⒸZ HYDRAULICKÝ ROZVOD - ZAHLUBOVÁNÍ

Ⓓ HYDRAULISCHE VERTEILUNG - EINSENKUNG

Ⓕ CONDUIT HYDRAULIQUE - L'ENFONCEMENT

ⒸB HYDRAULIC DISTRIBUTION - RECESSING

ⒸU ГИДРАВЛИЧЕСКОЕ РАСПРЕДЕЛЕНИЕ - ЗАГЛУБЛЕНИЕ

ⒸL HYDRAULICZNY PRZEWÓD - ZAGŁĘBIENIA

Farmet

VZ00017544

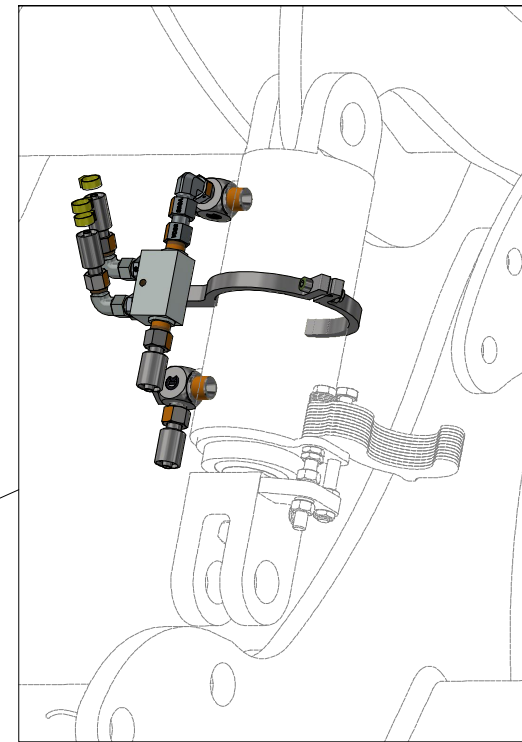
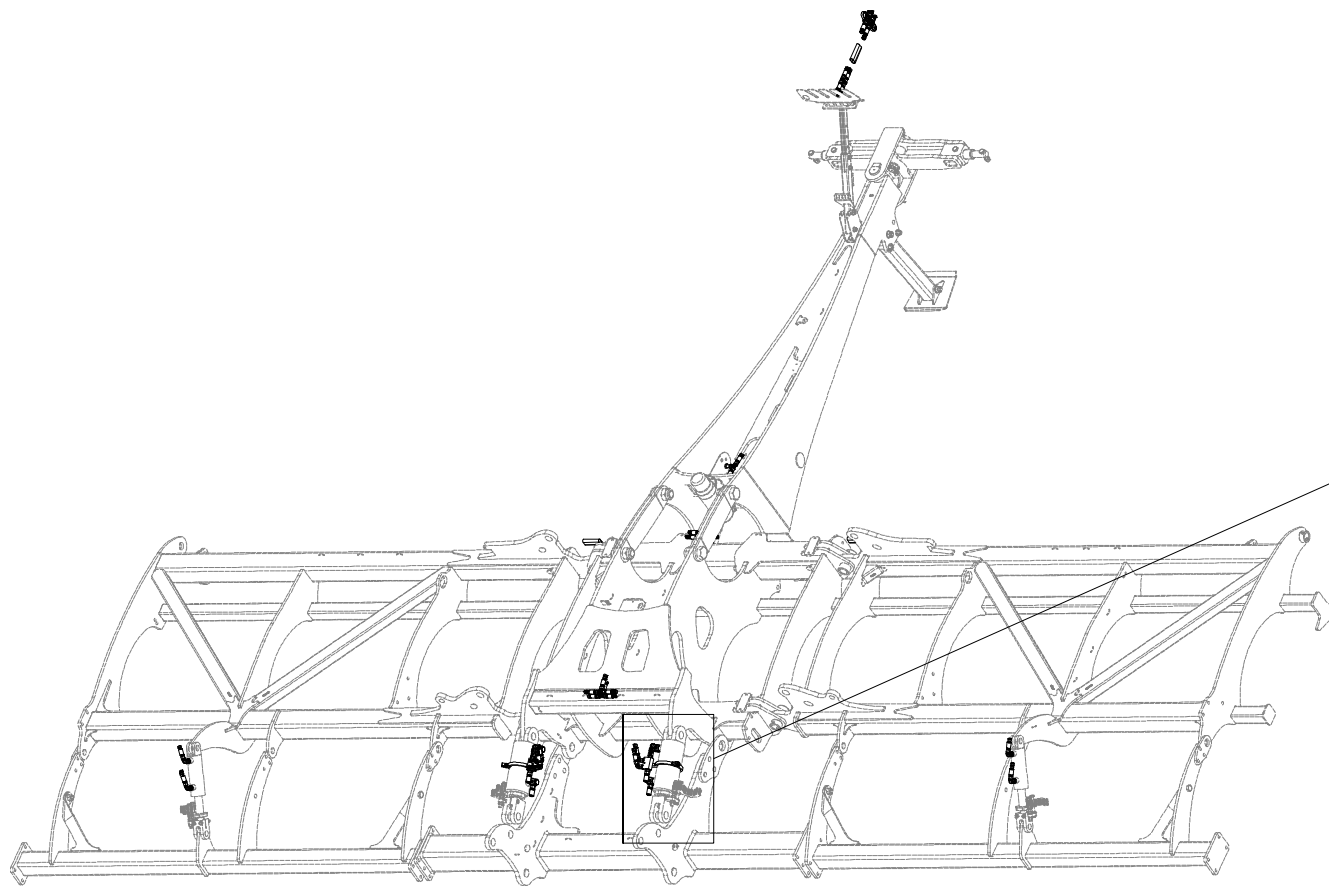

Pos.	Part Number	Pcs.
3	m07909	2
4	m04033	2
13	m03845	2
20	m08083	2
25	m20912	4
26	m06528	4
31	m06803	10
35	m22306	2
36	m07654	2
45	m10762	4
52	m11289	50
60	VZ00010112	2

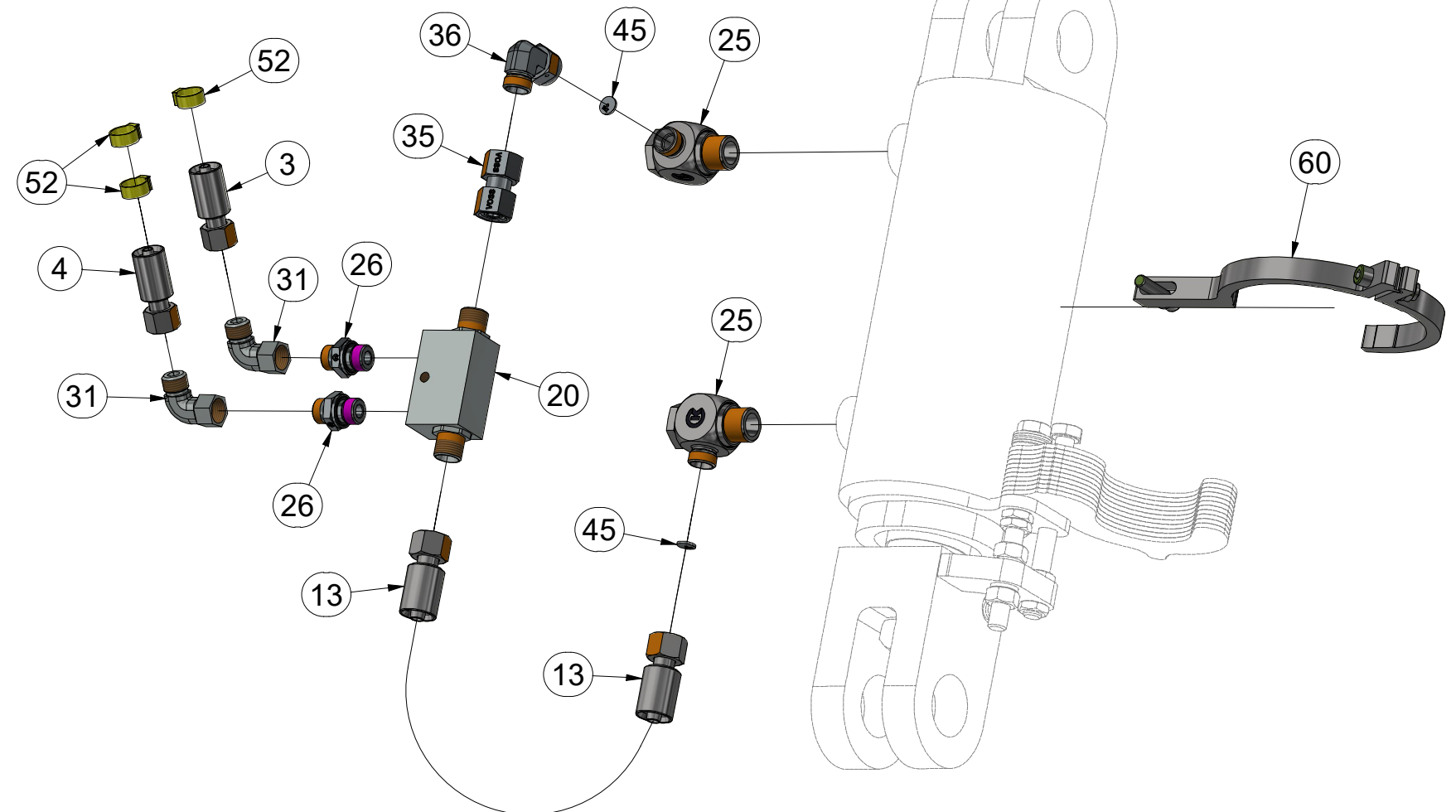

ⒸZ HYDRAULICKÝ ROZVOD - ZAHLUBOVÁNÍ

Ⓓ HYDRAULISCHE VERTEILUNG - EINSENKUNG

Ⓕ CONDUIT HYDRAULIQUE - L'ENFONCEMENT

ⒸB HYDRAULIC DISTRIBUTION - RECESSING

ⒸU ГИДРАВЛИЧЕСКОЕ РАСПРЕДЕЛЕНИЕ - ЗАГЛУБЛЕНИЕ

ⒸL HYDRAULICZNY PRZEWÓD - ZAGŁĘBIENIA



VZ00017544

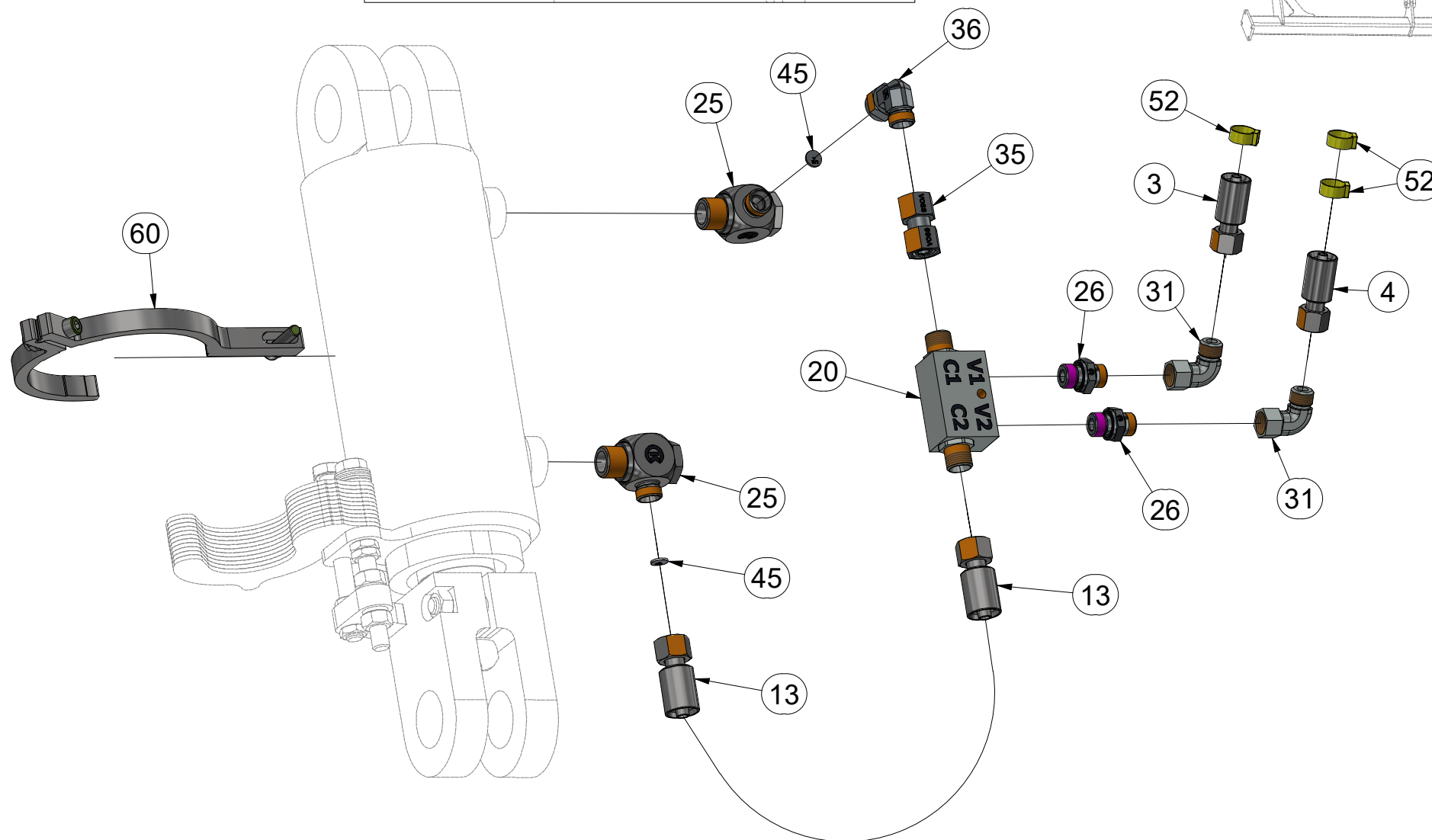
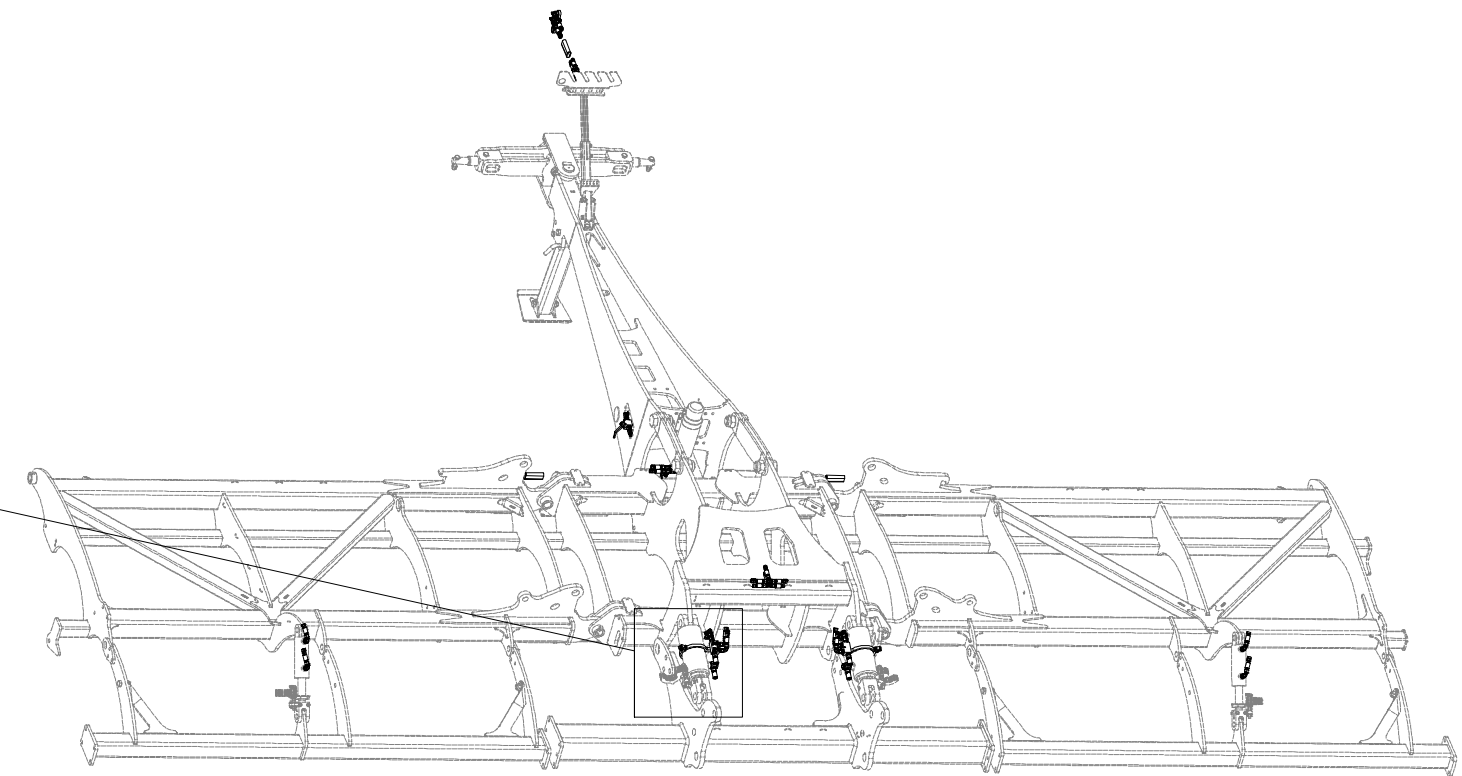
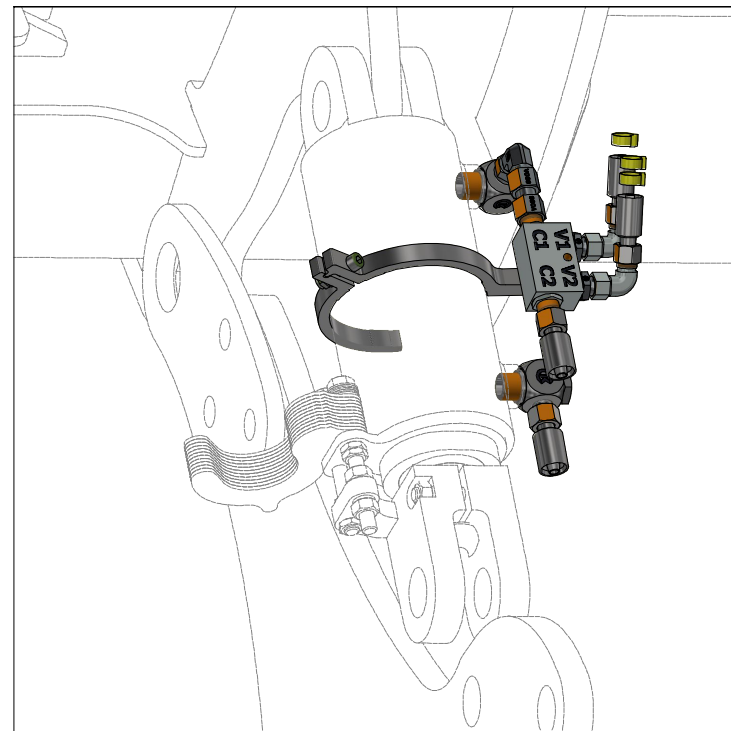

Pos.	Part Number	Pcs.
3	m07909	2
4	m04033	2
13	m03845	2
20	m08083	2
25	m20912	4
26	m06528	4
31	m06803	10
35	m22306	2
36	m07654	2
45	m10762	4
52	m11289	50
60	VZ00010112	2

ⒸZ HYDRAULICKÝ ROZVOD NÁPRAVY

Ⓓ HYDRAULISCHE VERTEILUNG ACHSE

Ⓕ CONDUIT HYDRAULIQUE DE L'ESSIEU

ⒸGB HYDRAULIC AXLE DISTRIBUTION

ⒸRU ГИДРАВЛИЧЕСКОЕ РАСПРЕДЕЛЕНИЕ ОСИ

ⒸPL HYDRAULICZNY PRZEWÓD OSI

Farmet

VZ00017588

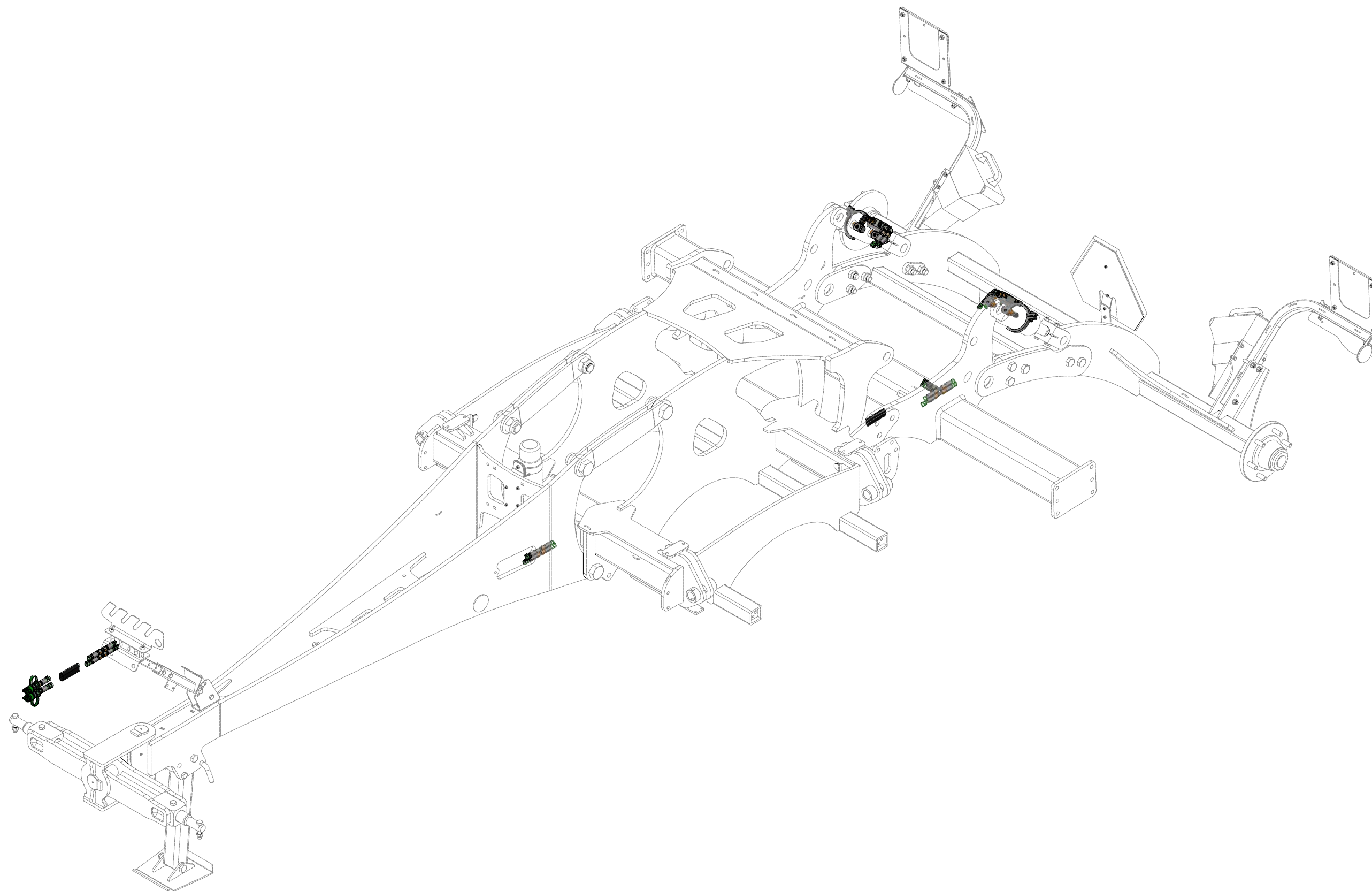

Ⓒ HYDRAULICKÝ ROZVOD NÁPRAVY

Ⓓ HYDRAULISCHE VERTEILUNG ACHSE

Ⓕ CONDUIT HYDRAULIQUE DE L'ESSIEU

Ⓖ HYDRAULIC AXLE DISTRIBUTION

Ⓡ ГИДРАВЛИЧЕСКОЕ РАСПРЕДЕЛЕНИЕ ОСИ

Ⓟ HYDRAULICZNY PRZEWÓD OSI



VZ00017588

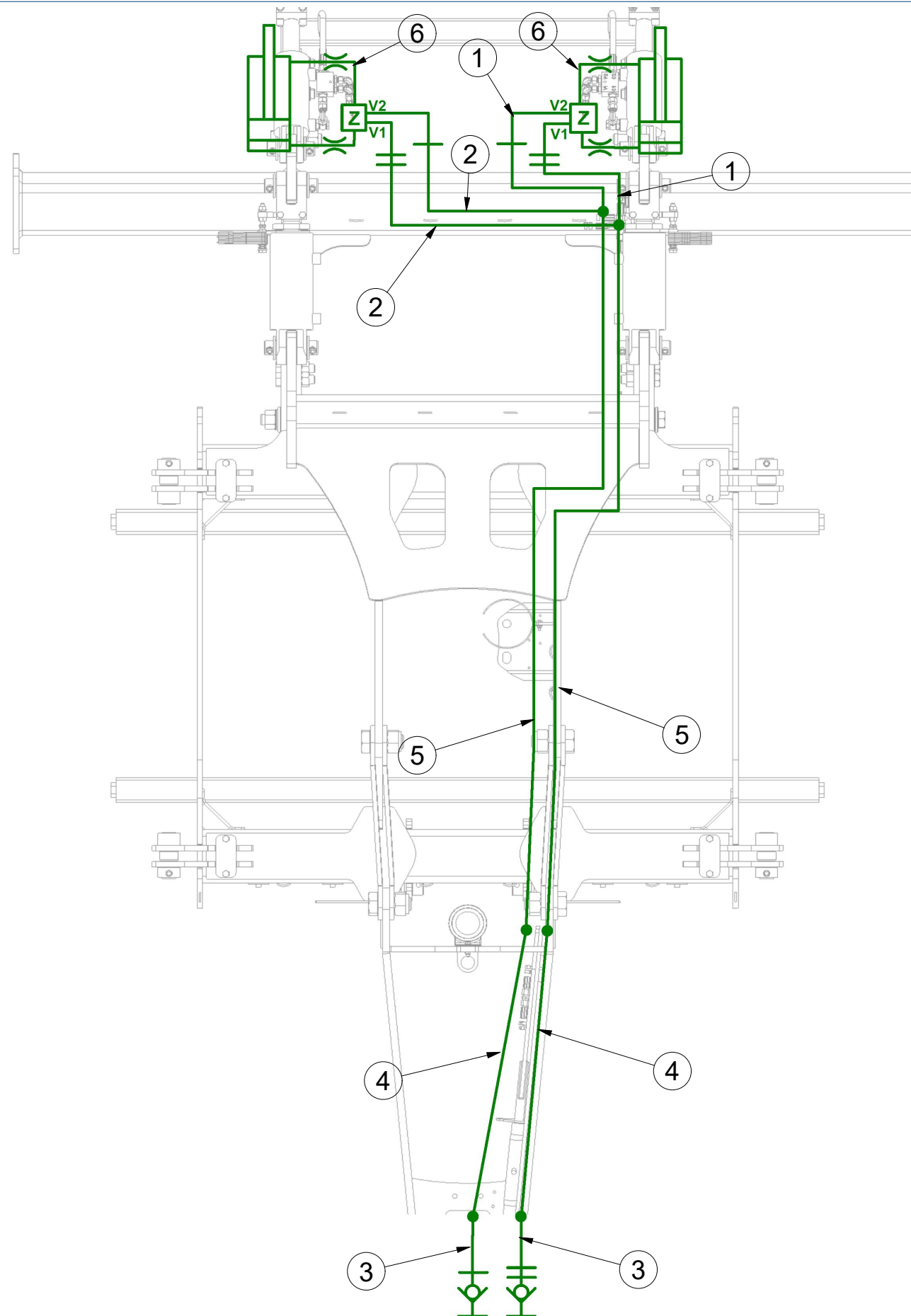

Pos.	Part Number	Pcs.
1	m04827	2
2	m07360	2
3	m11696	2
4	m07650	2
5	m12022	2
6	m03845	2

ⒸZ HYDRAULICKÝ ROZVOD NÁPRAVY

Ⓓ HYDRAULISCHE VERTEILUNG ACHSE

Ⓕ CONDUIT HYDRAULIQUE DE L'ESSIEU

ⒸB HYDRAULIC AXLE DISTRIBUTION

ⒸR ГИДРАВЛИЧЕСКОЕ РАСПРЕДЕЛЕНИЕ ОСИ

ⒸL HYDRAULICZNY PRZEWÓD OSI



VZ00017588

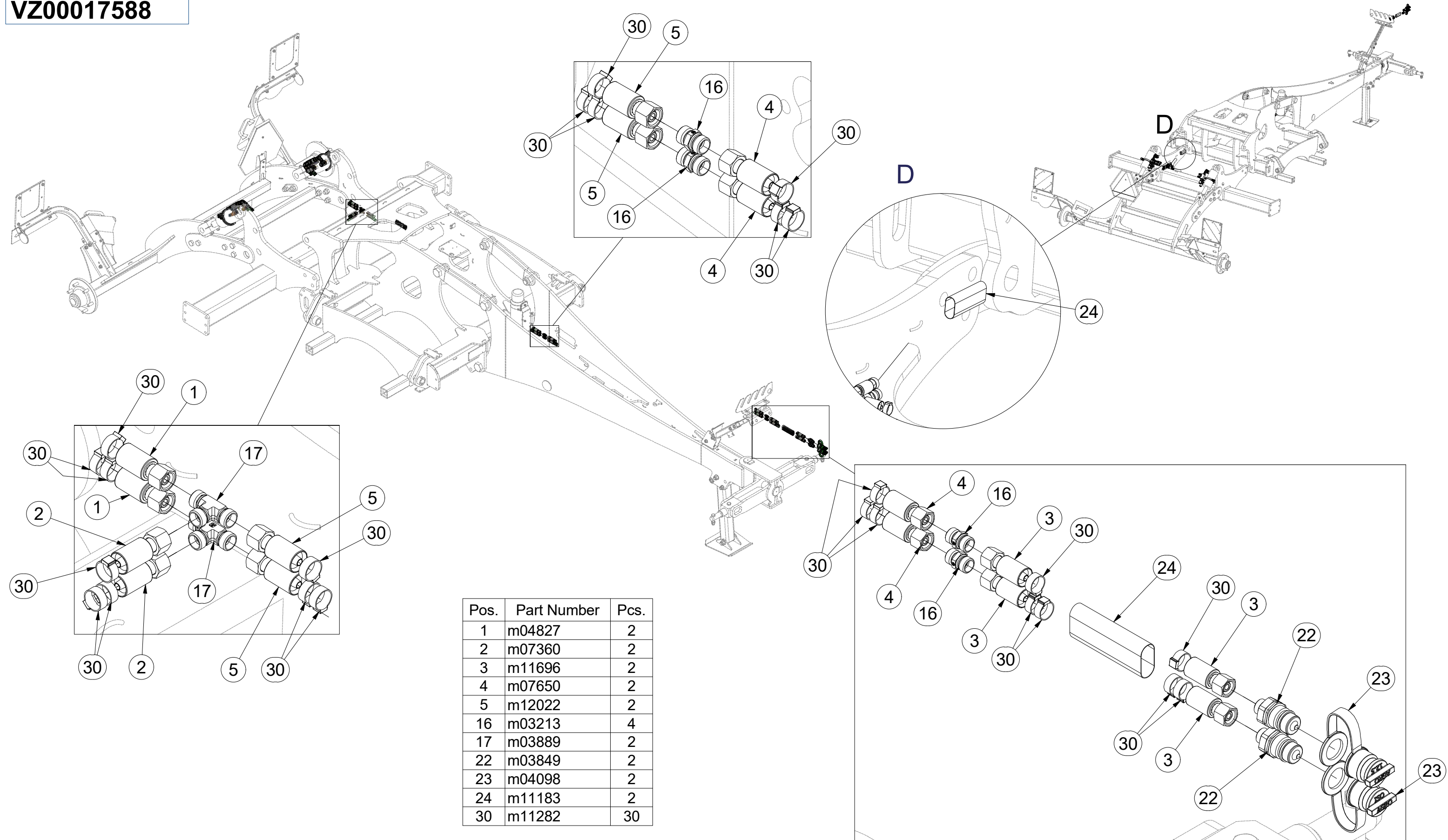

ⒸZ HYDRAULICKÝ ROZVOD NÁPRAVY

Ⓓ HYDRAULISCHE VERTEILUNG ACHSE

Ⓕ CONDUIT HYDRAULIQUE DE L'ESSIEU

VZ00017588

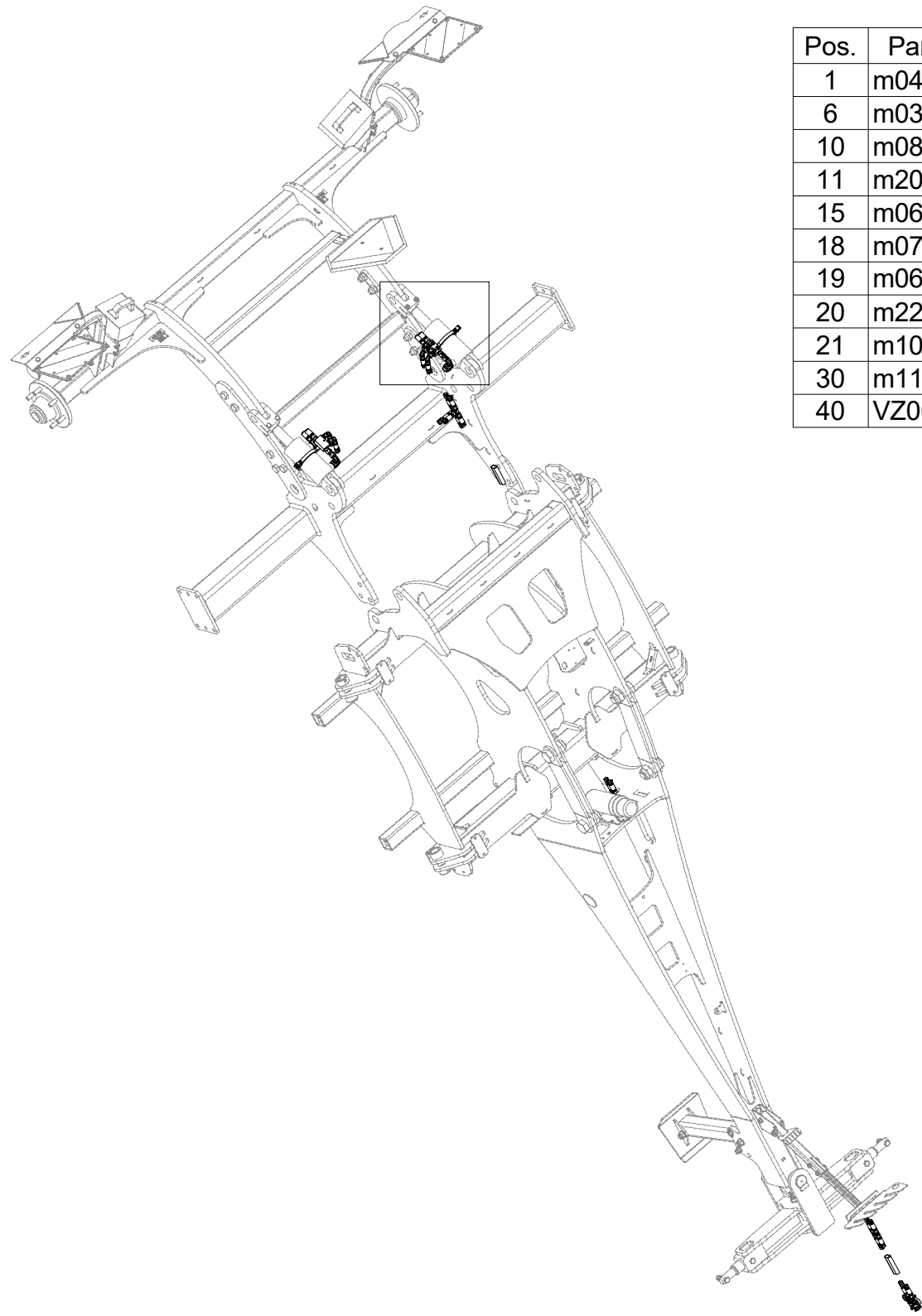

Pos.	Part Number	Pcs.
1	m04827	2
6	m03845	2
10	m08083	2
11	m20912	4
15	m06528	4
18	m07654	2
19	m06803	4
20	m22306	2
21	m10776	4
30	m11282	30
40	VZ00010409	2

ⒸB HYDRAULIC AXLE DISTRIBUTION

Ⓔ ГИДРАВЛИЧЕСКОЕ РАСПРЕДЕЛЕНИЕ ОСИ

Ⓗ HYDRAULICZNY PRZEWÓD OSI

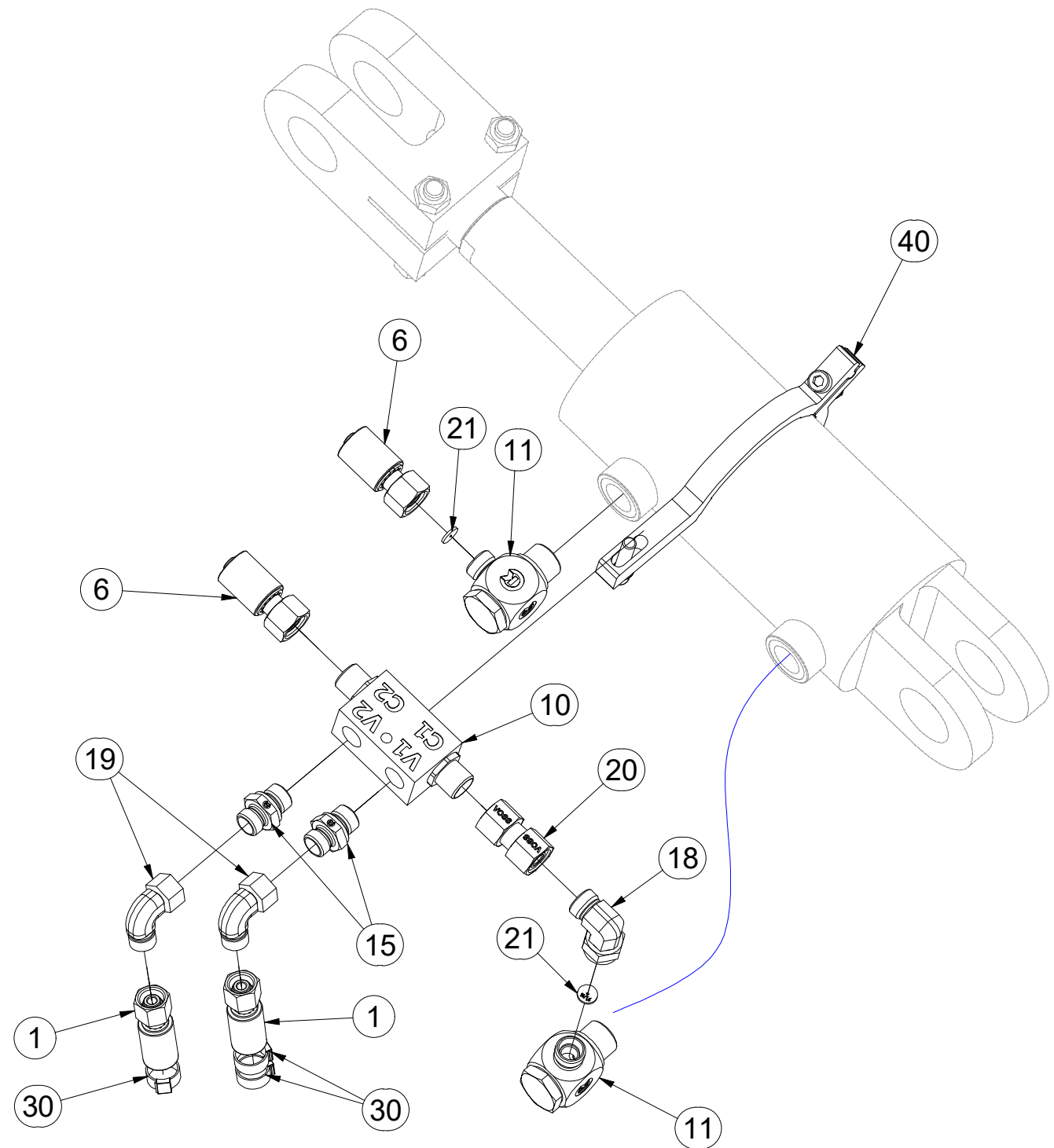

ⒸZ HYDRAULICKÝ ROZVOD NÁPRAVY

Ⓓ HYDRAULISCHE VERTEILUNG ACHSE

Ⓕ CONDUIT HYDRAULIQUE DE L'ESSIEU

ⒸB HYDRAULIC AXLE DISTRIBUTION

ⒸU ГИДРАВЛИЧЕСКОЕ РАСПРЕДЕЛЕНИЕ ОСИ

ⒸL HYDRAULICZNY PRZEWÓD OSI

Farmet

VZ00017588

Pos.	Part Number	Pcs.
2	m07360	2
6	m03845	2
10	m08083	2
11	m20912	4
15	m06528	4
18	m07654	2
19	m06803	4
20	m22306	2
21	m10776	4
30	m11282	30
40	VZ00010409	2

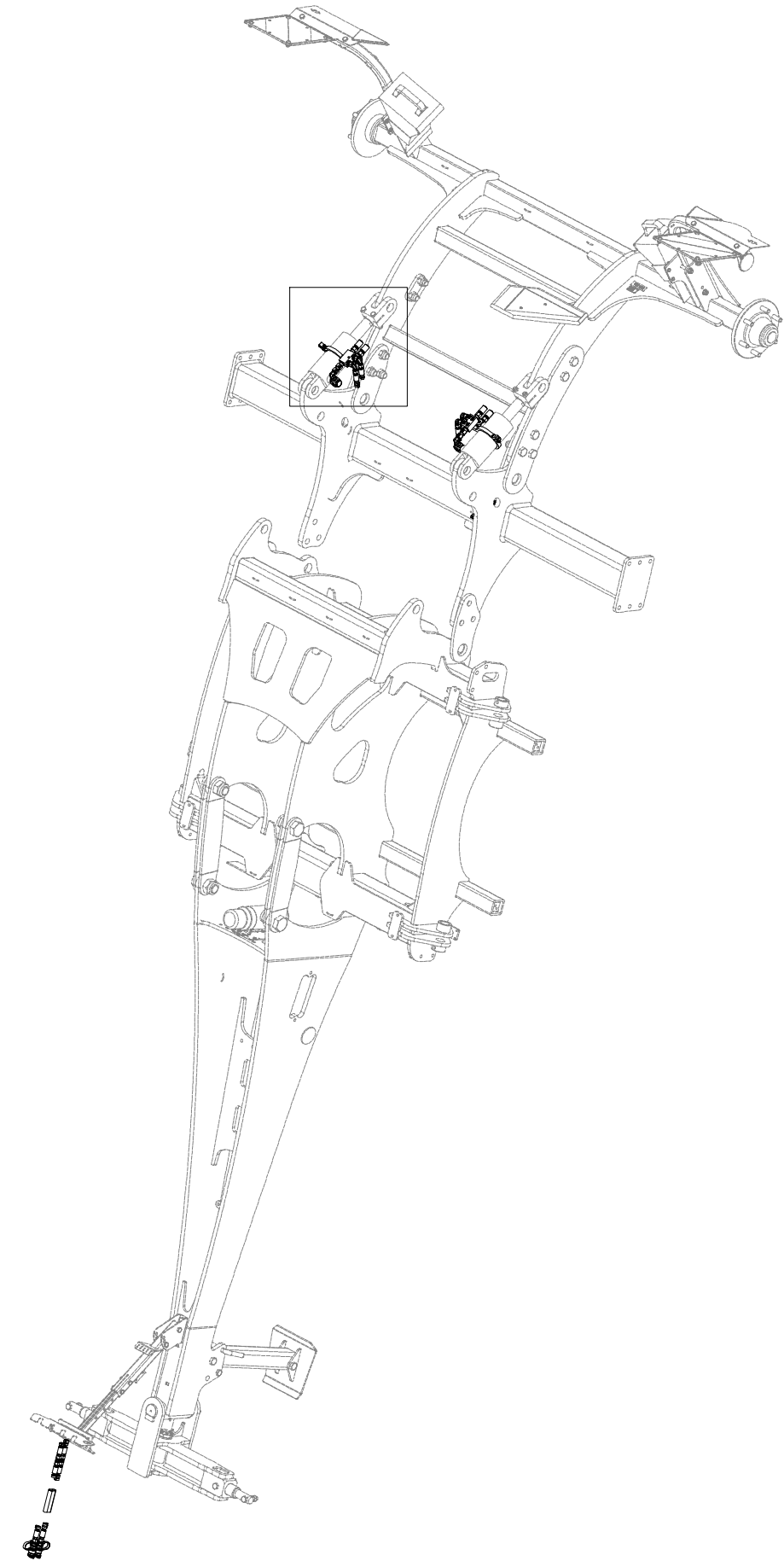
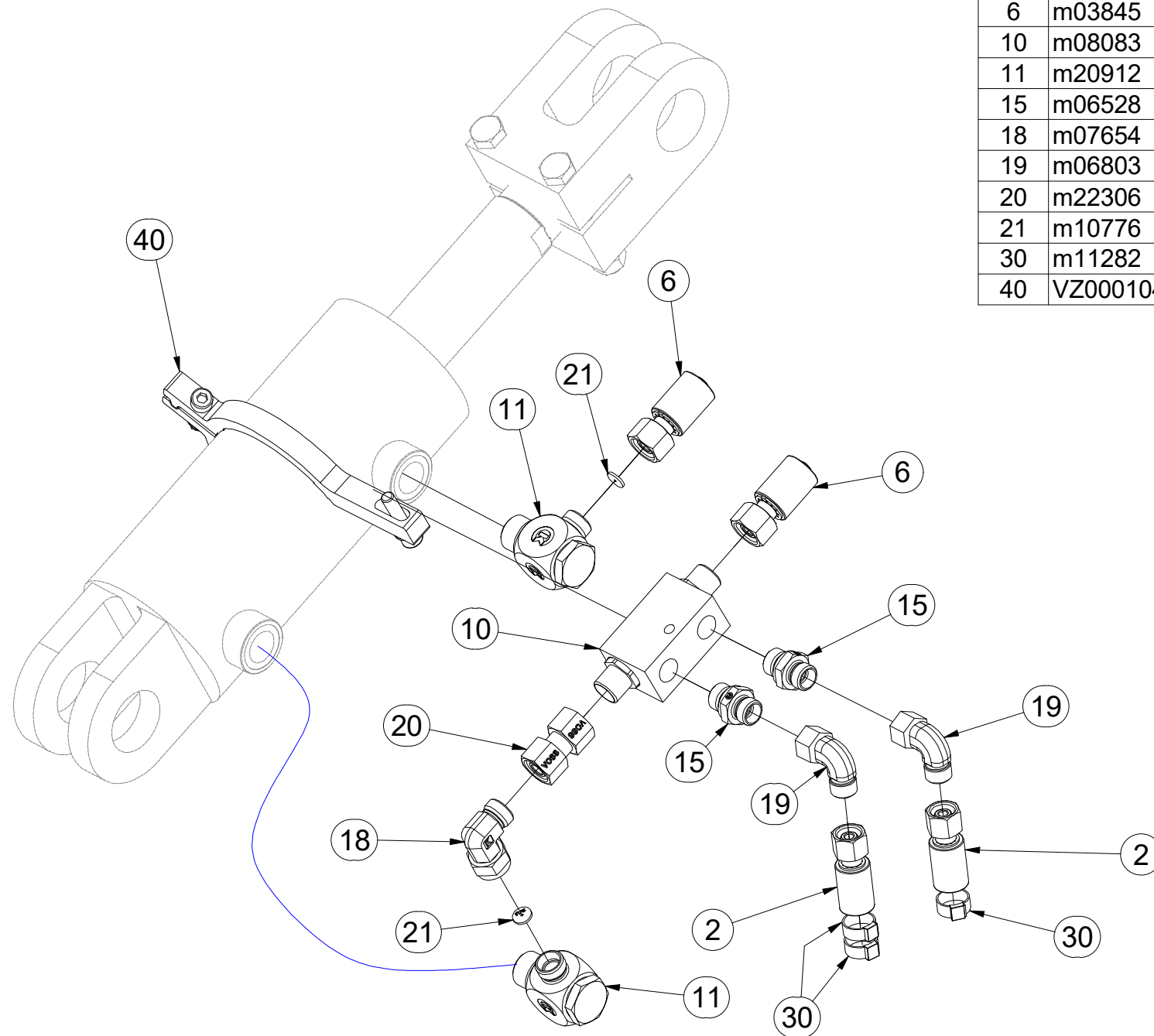

- Ⓒ DRŽÁK
- Ⓓ HALTER
- Ⓕ SUPPORT

- Ⓖ HOLDER
- Ⓡ ДЕРЖАТЕЛЬ
- Ⓟ UCHWYT



VZ00010112

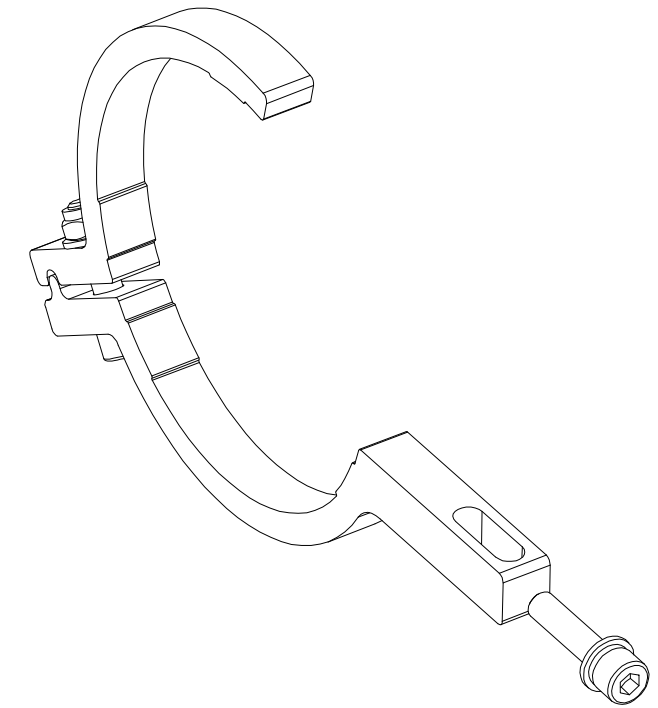
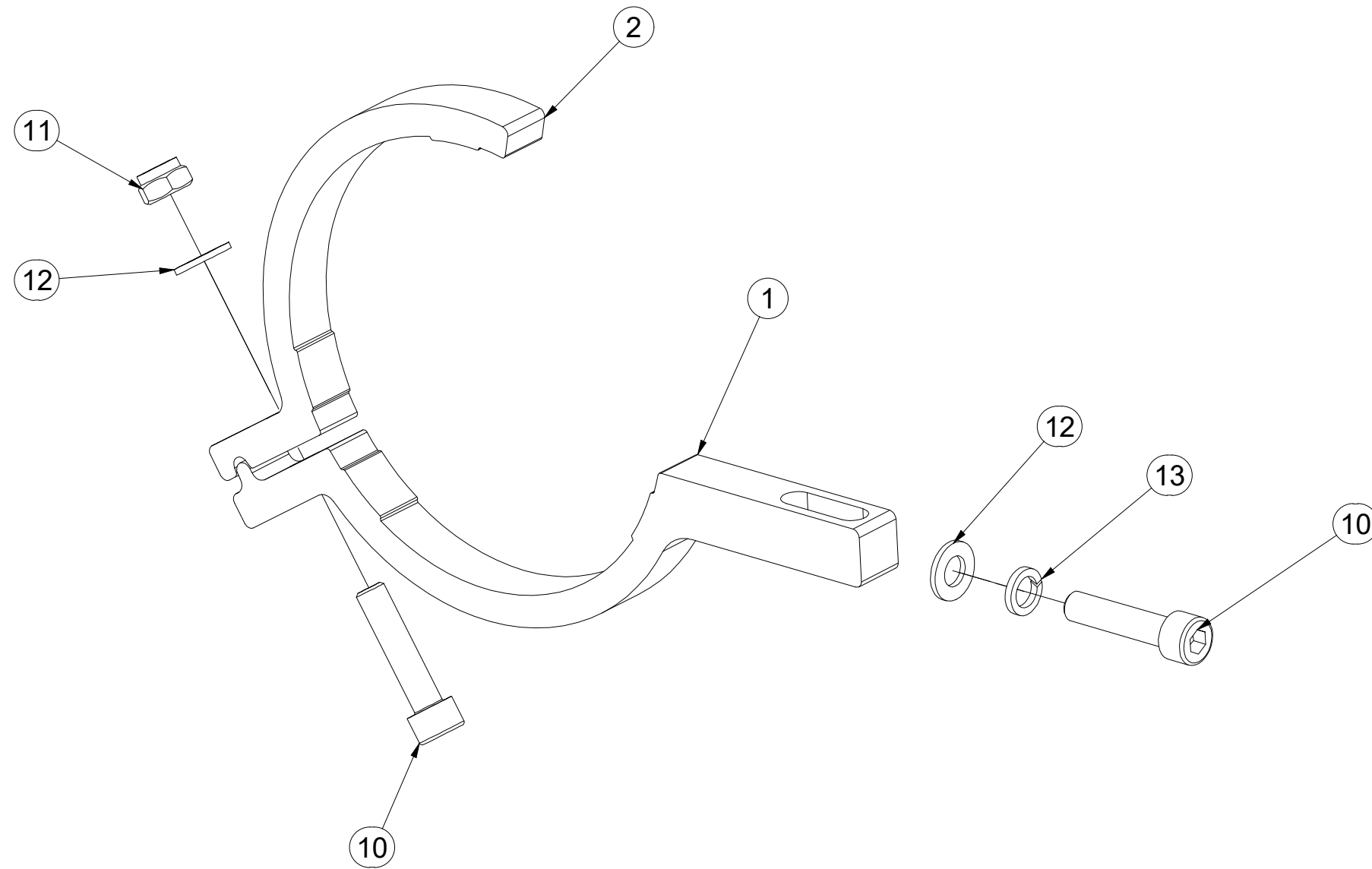

Pos.	Part Number	Pcs.
1	VZ00010113	1
2	VZ00010114	1
10	m09464	2
11	m04503	1
12	m01203	2
13	m01202	1

- ⒸZ DRŽÁK
- Ⓓ HALTER
- Ⓕ SUPPORT

- ⒼB HOLDER
- ⒶRU ДЕРЖАТЕЛЬ
- ⒶPL UCHWYT



VZ00010409

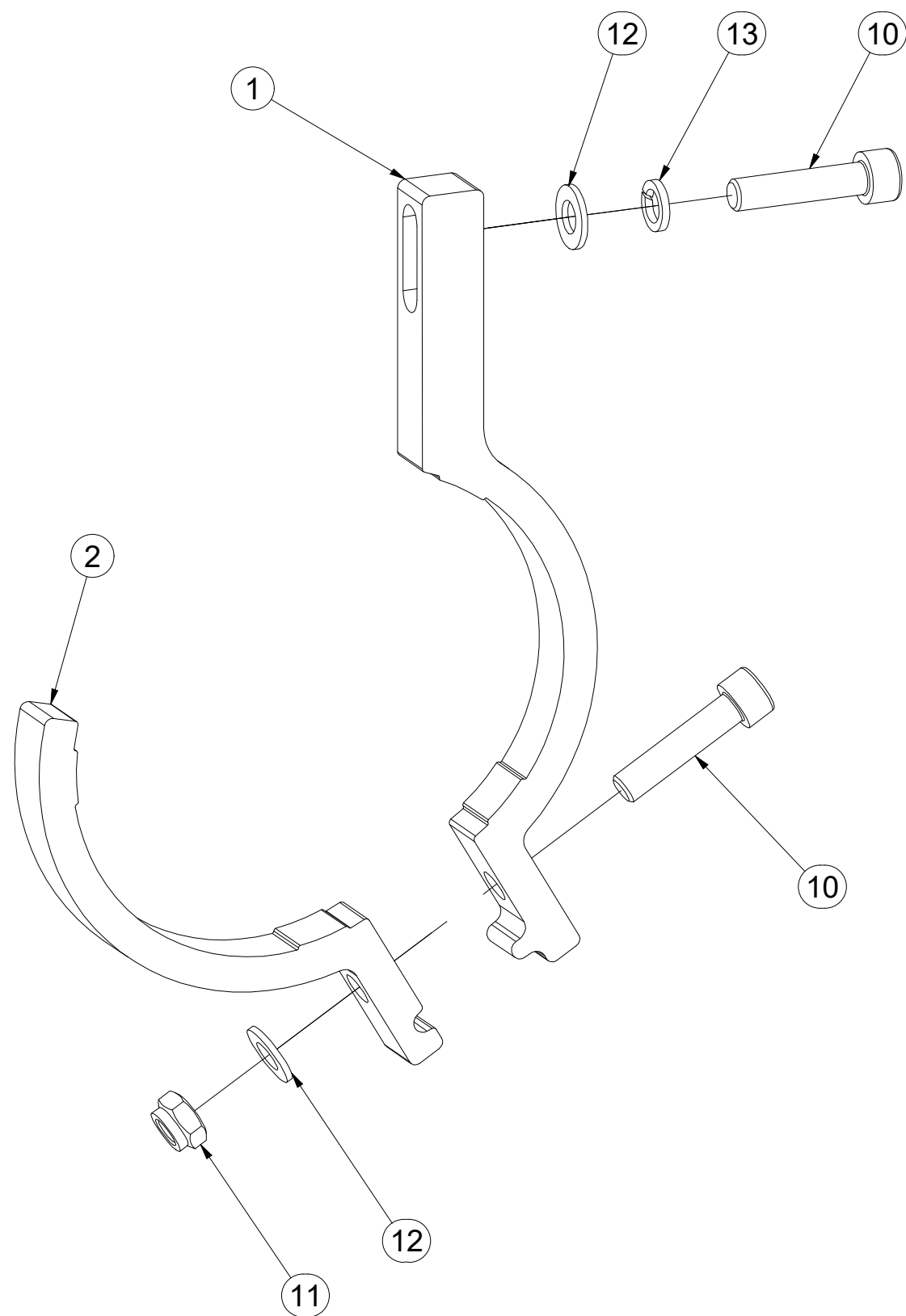

Pos.	Part Number	Pcs.
1	VZ00010410	1
2	VZ00010408	1
10	m09464	2
11	m04503	1
12	m01203	2
13	m01202	1

Ⓒ PÍSTNICE 63/40-95

Ⓓ KOLBENSTANGE 63/40-95

Ⓕ TIGE DE PISTON 63/40-95

Ⓒ PISTON ROD 63/40-95

Ⓓ ЦИЛИНДР 63/40-95

Ⓒ TRZPIEŃ TŁOKA 63/40-95



VZ00036780

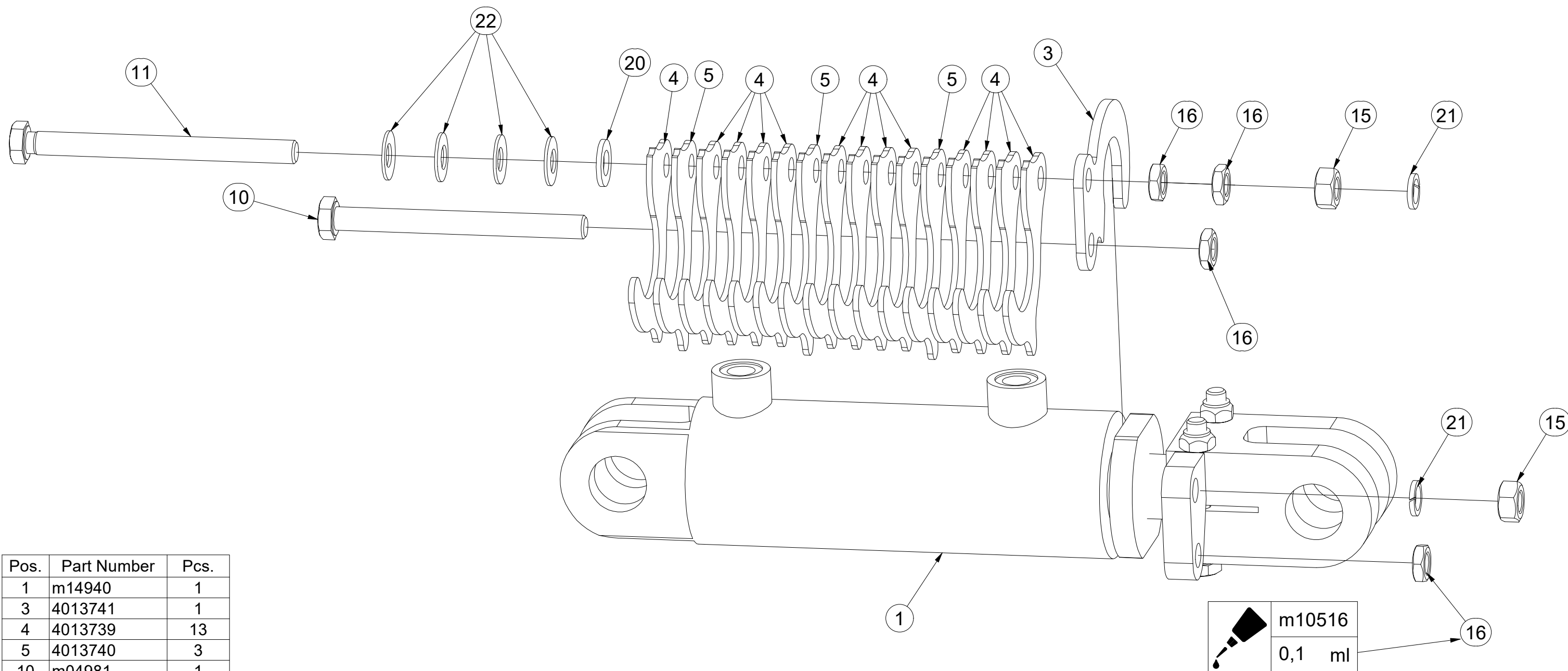

Pos.	Part Number	Pcs.
1	m14940	1
3	4013741	1
4	4013739	13
5	4013740	3
10	m04981	1
11	m16072	1
15	m01305	2
16	m14233	4
20	m01214	1
21	m03988	2
22	m17728	4
30	m10516	0,10 ml

Ⓒ PÍSTNICE 63/40-95

Ⓓ KOLBENSTANGE 63/40-95

Ⓕ TIGE DE PISTON 63/40-95

Ⓖ PISTON ROD 63/40-95

Ⓡ ЦИЛИНДР 63/40-95

Ⓟ TRZPIEŃ TŁOKA 63/40-95



VZ00036781

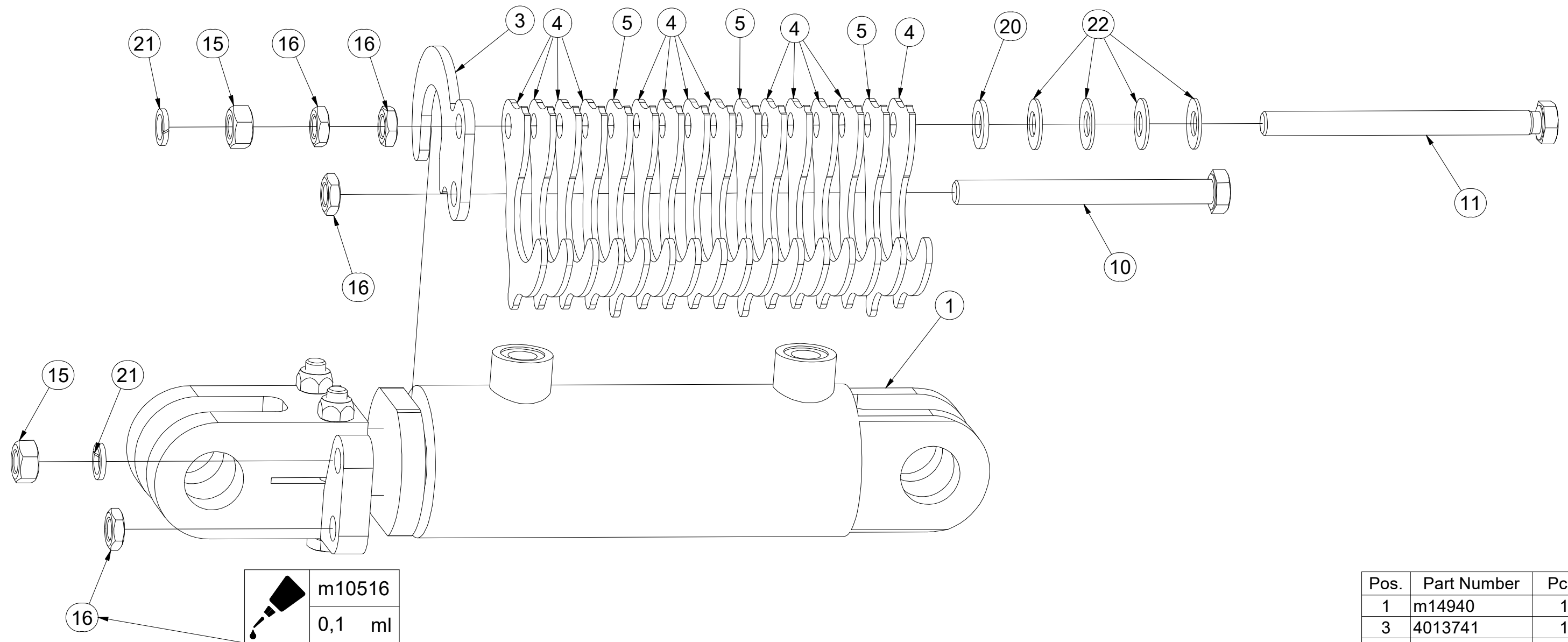

Pos.	Part Number	Pcs.
1	m14940	1
3	4013741	1
4	4013739	13
5	4013740	3
10	m04981	1
11	m16072	1
15	m01305	2
16	m14233	4
20	m01214	1
21	m03988	2
22	m17728	4
30	m10516	0,10 ml

Ⓒ PÍSTNICE 110/56-100

Ⓓ KOLBENSTANGE 110/56-100

Ⓕ TIGE DE PISTON 110/56-100

Ⓖ PISTON ROD 110/56-100

Ⓡ ЦИЛИНДР 110/56-100

Ⓟ TRZPIEŃ TŁOKA 110/56-100



VZ00036786

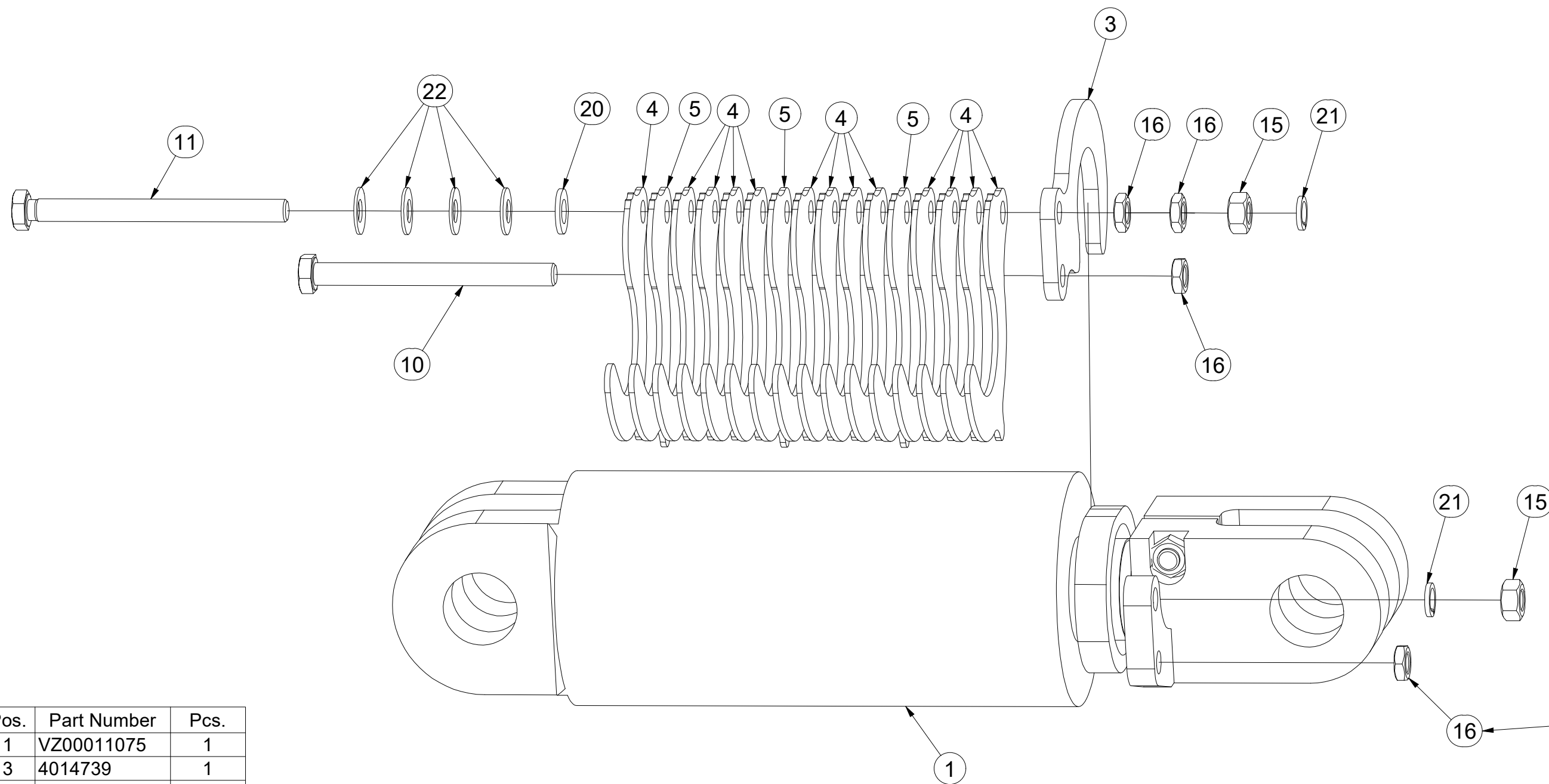

Pos.	Part Number	Pcs.
1	VZ00011075	1
3	4014739	1
4	4014740	13
5	4014741	3
10	m04981	1
11	m16072	1
15	m01305	2
16	m14233	4
20	m01214	1
21	m03988	2
22	m17728	4
30	m10516	0,10 ml

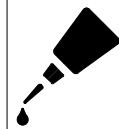
 m10516
0,1 ml

Ⓒ PÍSTNICE 110/56-100

Ⓓ KOLBENSTANGE 110/56-100

Ⓕ TIGE DE PISTON 110/56-100

Ⓖ PISTON ROD 110/56-100

Ⓒ ЦИЛИНДР 110/56-100

Ⓗ TRZPIEŃ TŁOKA 110/56-100



VZ00036787

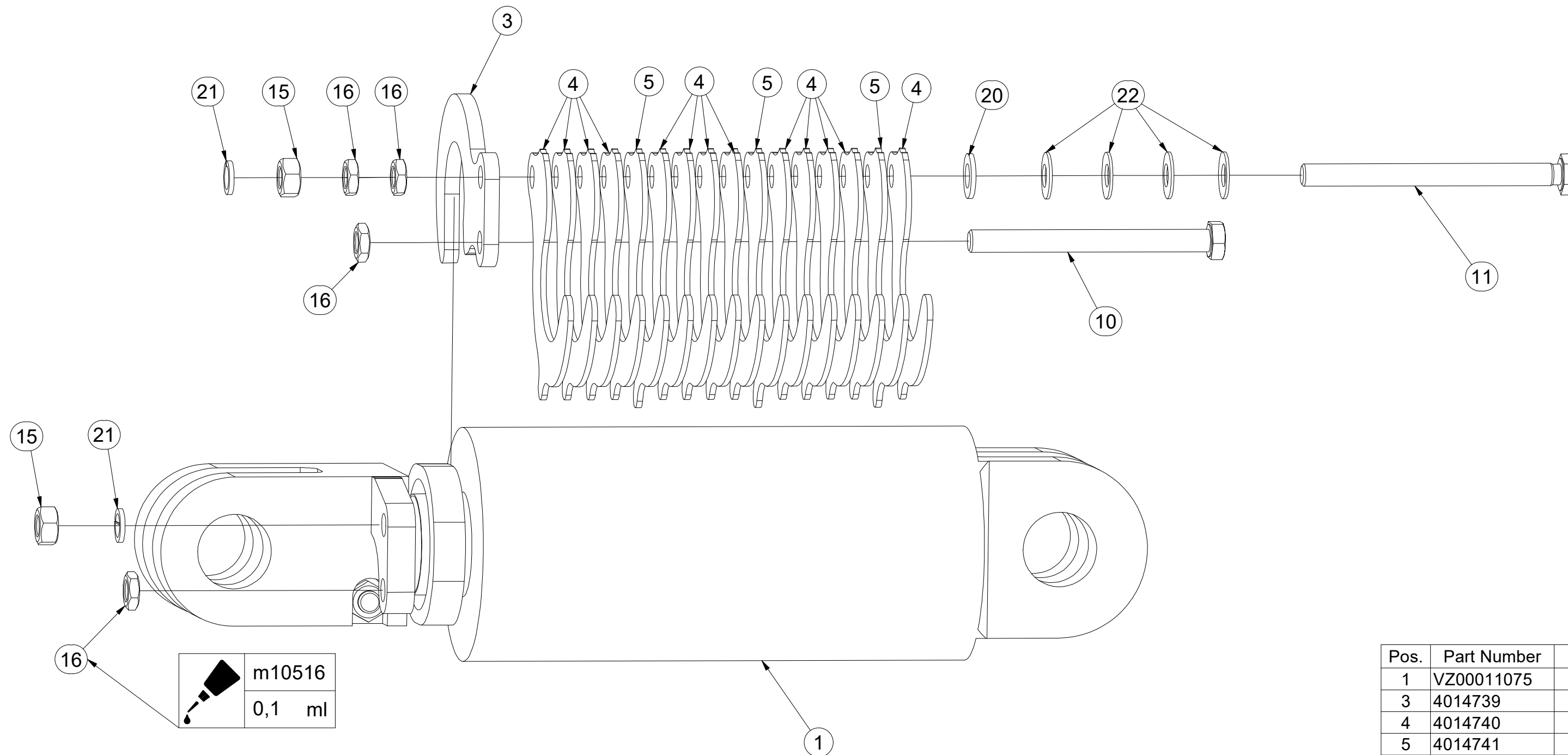

Pos.	Part Number	Pcs.
1	VZ00011075	1
3	4014739	1
4	4014740	13
5	4014741	3
10	m04981	1
11	m16072	1
15	m01305	2
16	m14233	4
20	m01214	1
21	m03988	2
22	m17728	4
30	m10516	0,10 ml

Ⓒ PÍSTNICE 110/56-100

Ⓓ KOLBENSTANGE 110/56-100

Ⓕ TIGE DE PISTON 110/56-100

Ⓖ PISTON ROD 110/56-100

Ⓡ ЦИЛИНДР 110/56-100

Ⓟ TRZPIEŃ TŁOKA 110/56-100

Farmet

VZ00011075

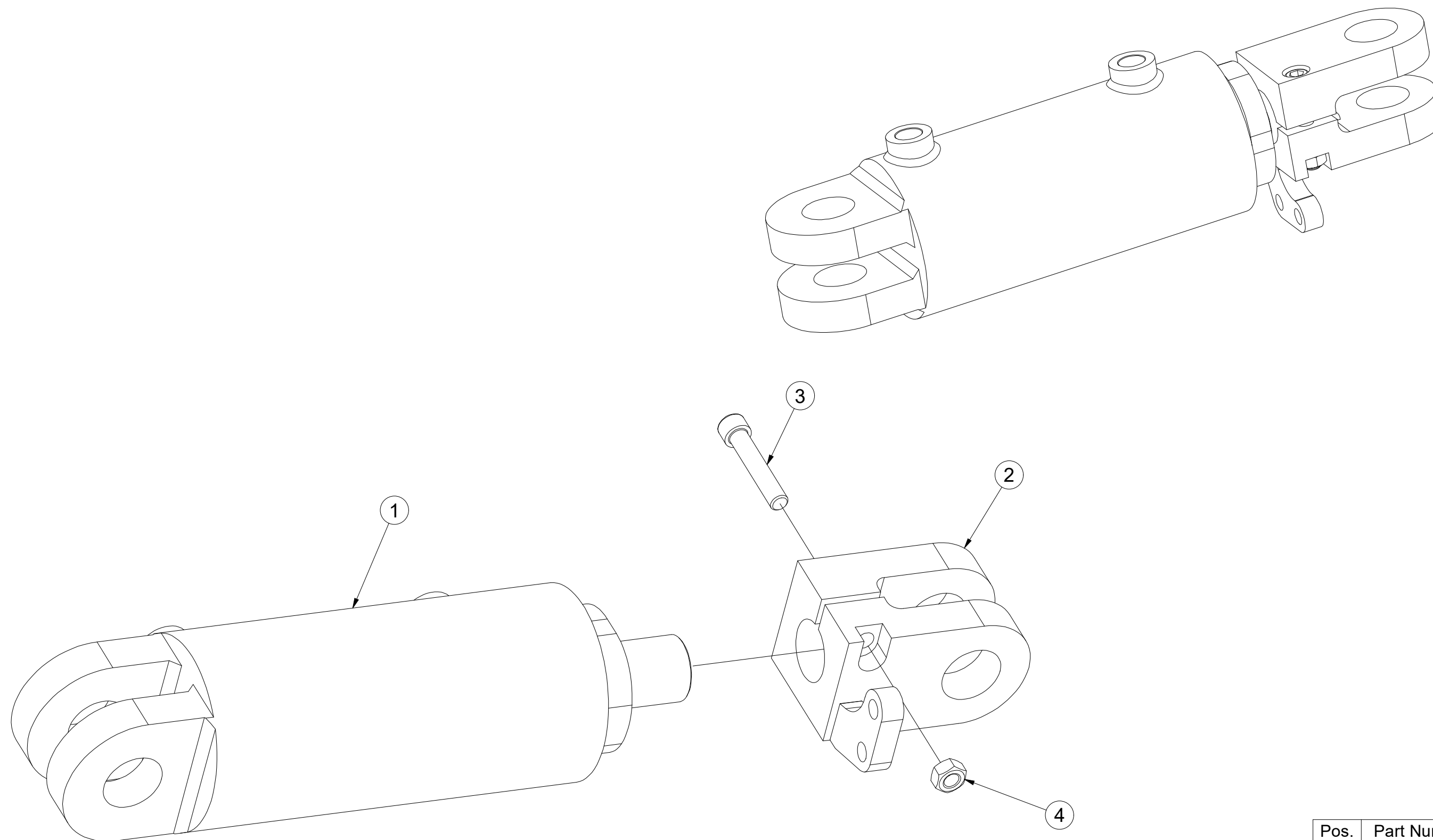

Pos.	Part Number	Pcs.
1	m21020	1
2	m20347	1
3	m14867	1
4	m10439	1

Ⓒ CZ SOUPRAVA TĚSNIVA PÍSTNIC

Ⓓ D KOLBENSTANGENDICHTUNGSMITTELSATZ

Ⓕ F SET DE GARNITURE DES TIGES DE PISTON

Ⓖ GB SEALING SET FOR PISTON RODS

Ⓔ RU КОМПЛЕКТ ПРОКЛАДОК ЦИЛИНДРОВ

Ⓗ PL ZESTAW USZCZELEK TRZPIENIA TŁOKA

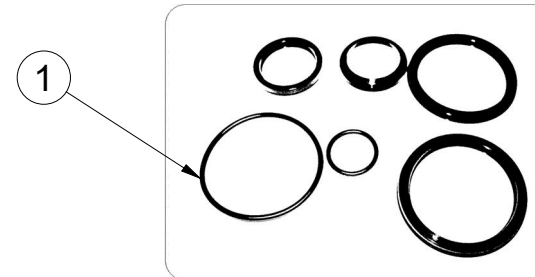
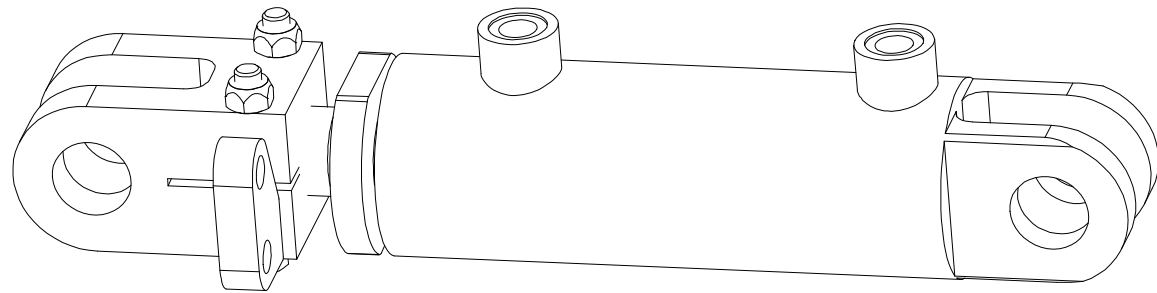

m14940 - $\varnothing 63/\varnothing 40-95$		
Pos	Part number	Pcs
1	m15372	2

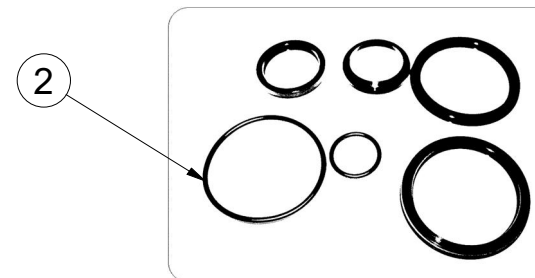
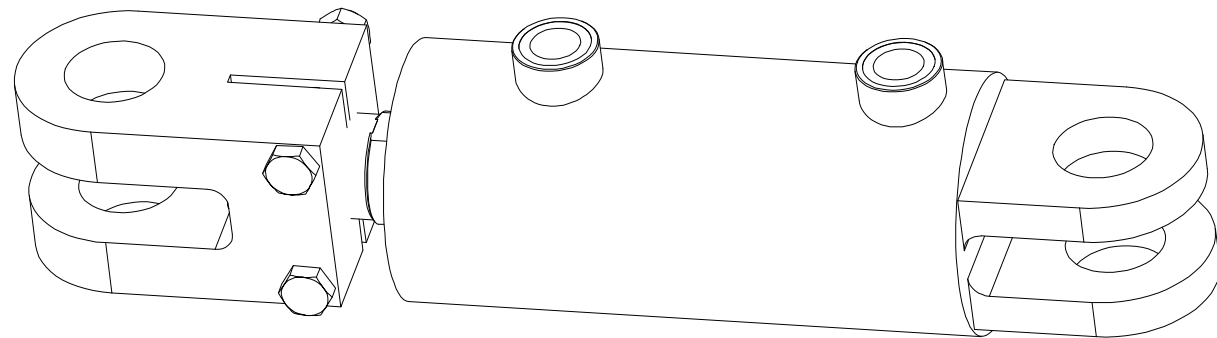

m17172 - $\varnothing 90/\varnothing 45-100$		
Pos	Part number	Pcs
2	m15374	2

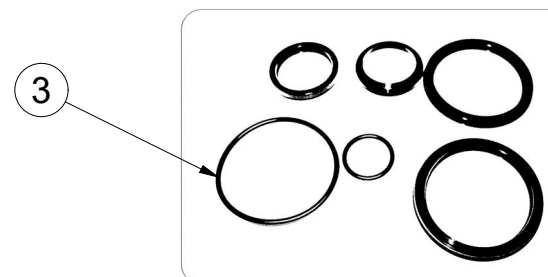
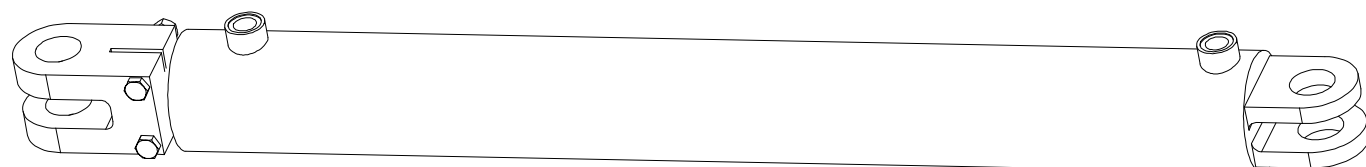

m21525 - $\varnothing 90/\varnothing 45-830$		
Pos	Part number	Pcs
3	m22828	2

☉ SAMOLEPKY STROJE

☉ AUFKLEBER MASCHINEN

☉ VOITURE MACHINES

☉ STICKERS MACHINES

☉ СТИКЕРЫ МАШИНЫ

☉ NAKLEJKI MASZYNY



VZ00037580

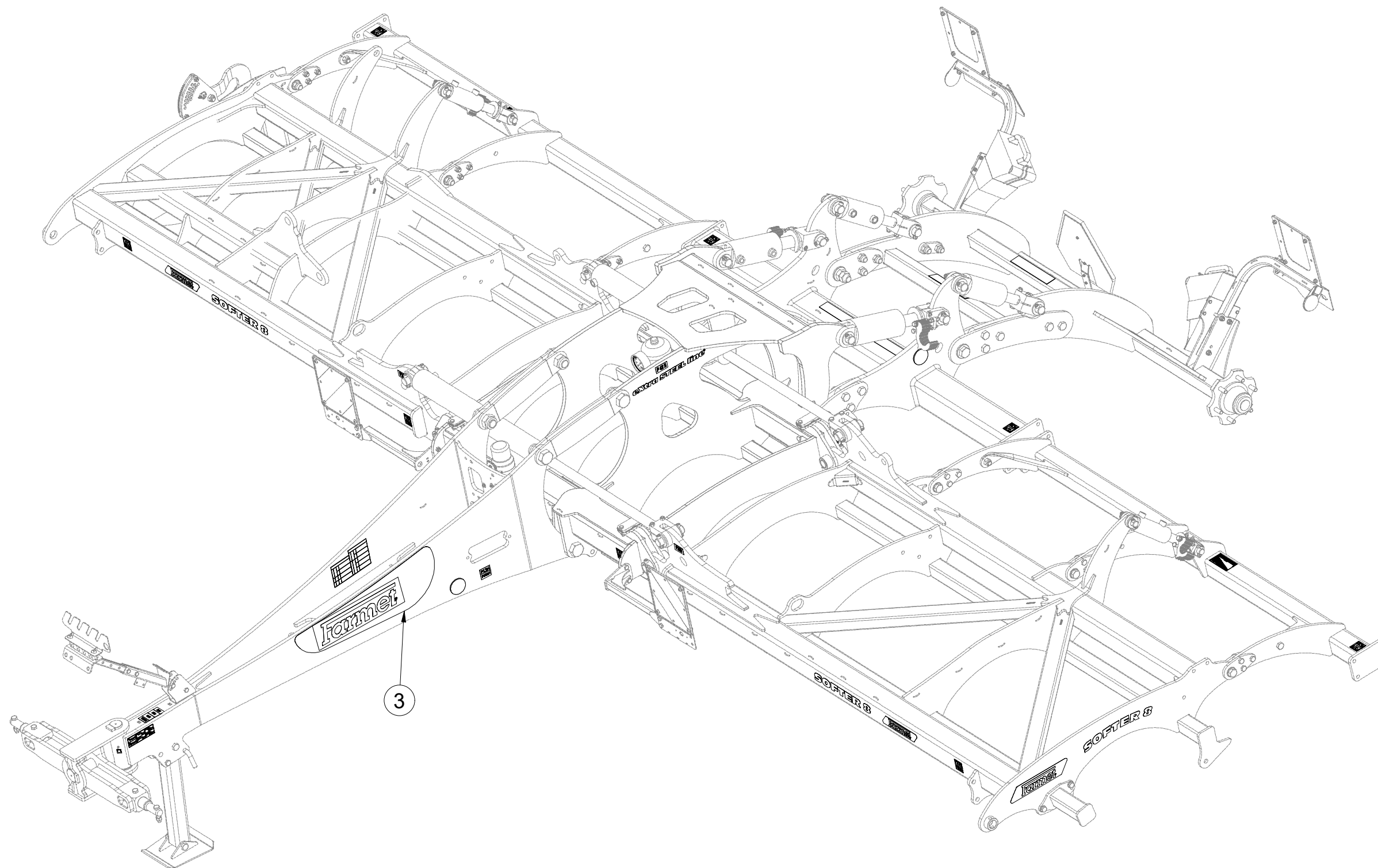

Pos.	Part Number	Pcs.
3	m24227	1

☉ SAMOLEPKY STROJE

☉ AUFKLEBER MASCHINEN

☉ VOITURE MACHINES

☉ STICKERS MACHINES

☉ СТИКЕРЫ МАШИНЫ

☉ NAKLEJKI MASZYNY



VZ00037580

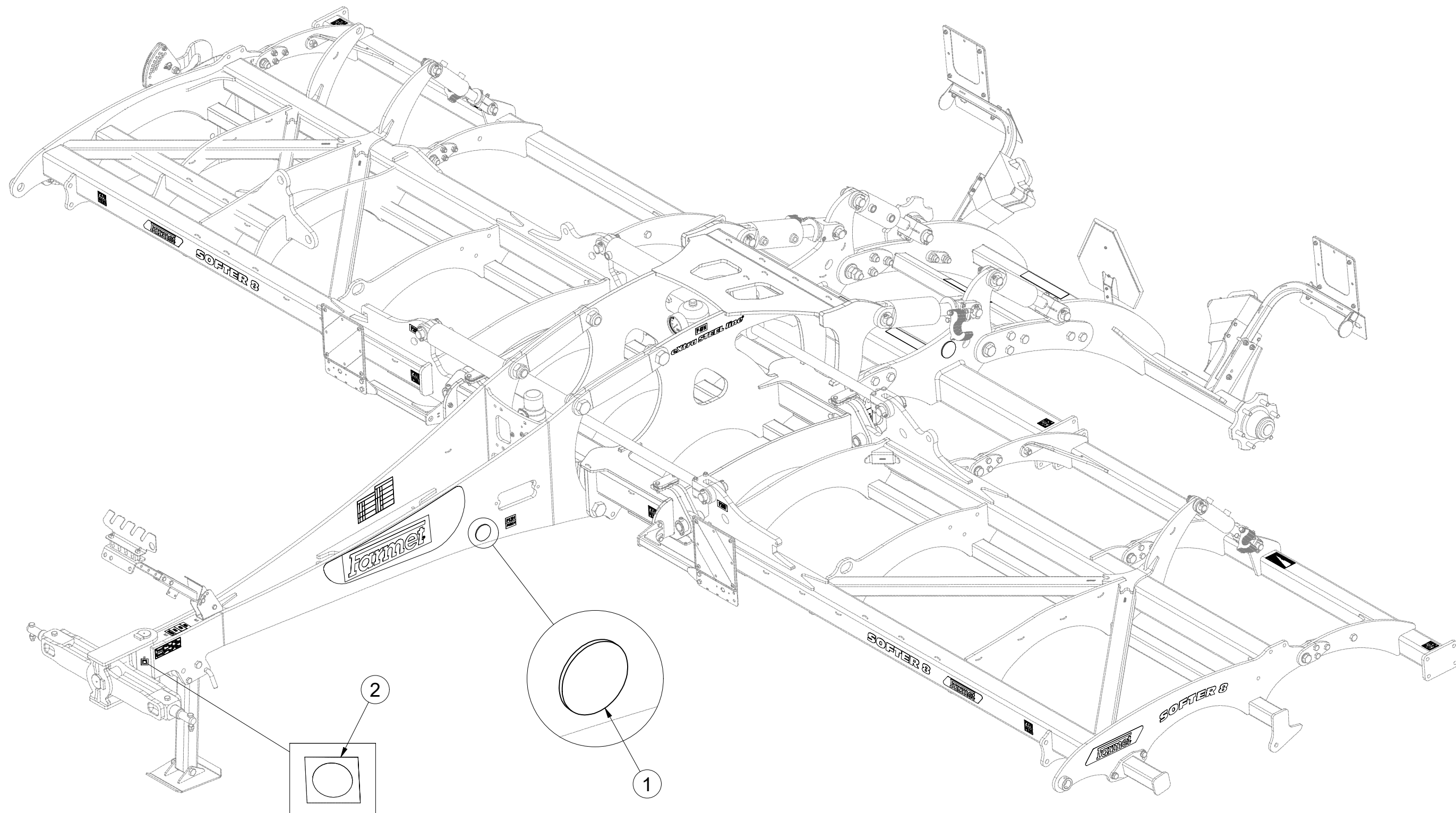

Pos.	Part Number	Pcs.
1	m02579	4
2	m03320	1

- Ⓒ SAMOLEPKY STROJE
- Ⓓ AUFKLEBER MASCHINEN
- Ⓕ VOITURE MACHINES

- Ⓖ STICKERS MACHINES
- Ⓡ СТИКЕРЫ МАШИНЫ
- Ⓟ NAKLEJKI MASZYNY



m24227

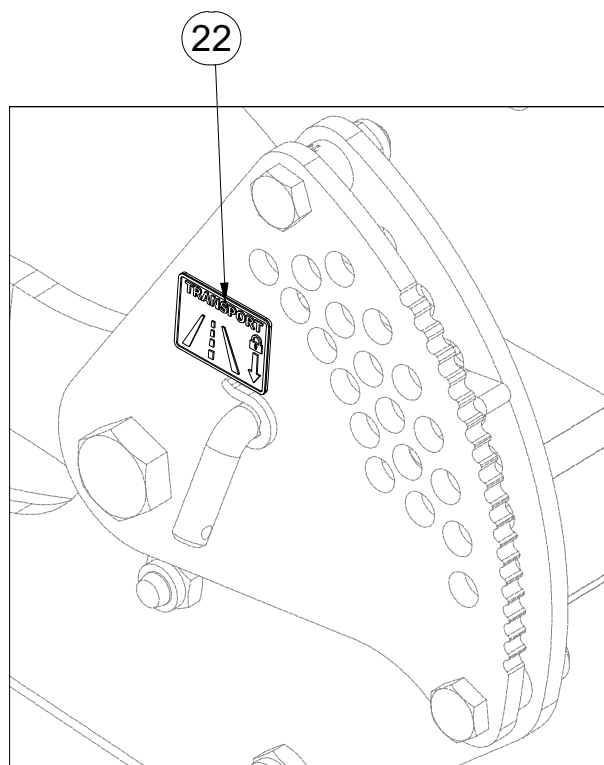
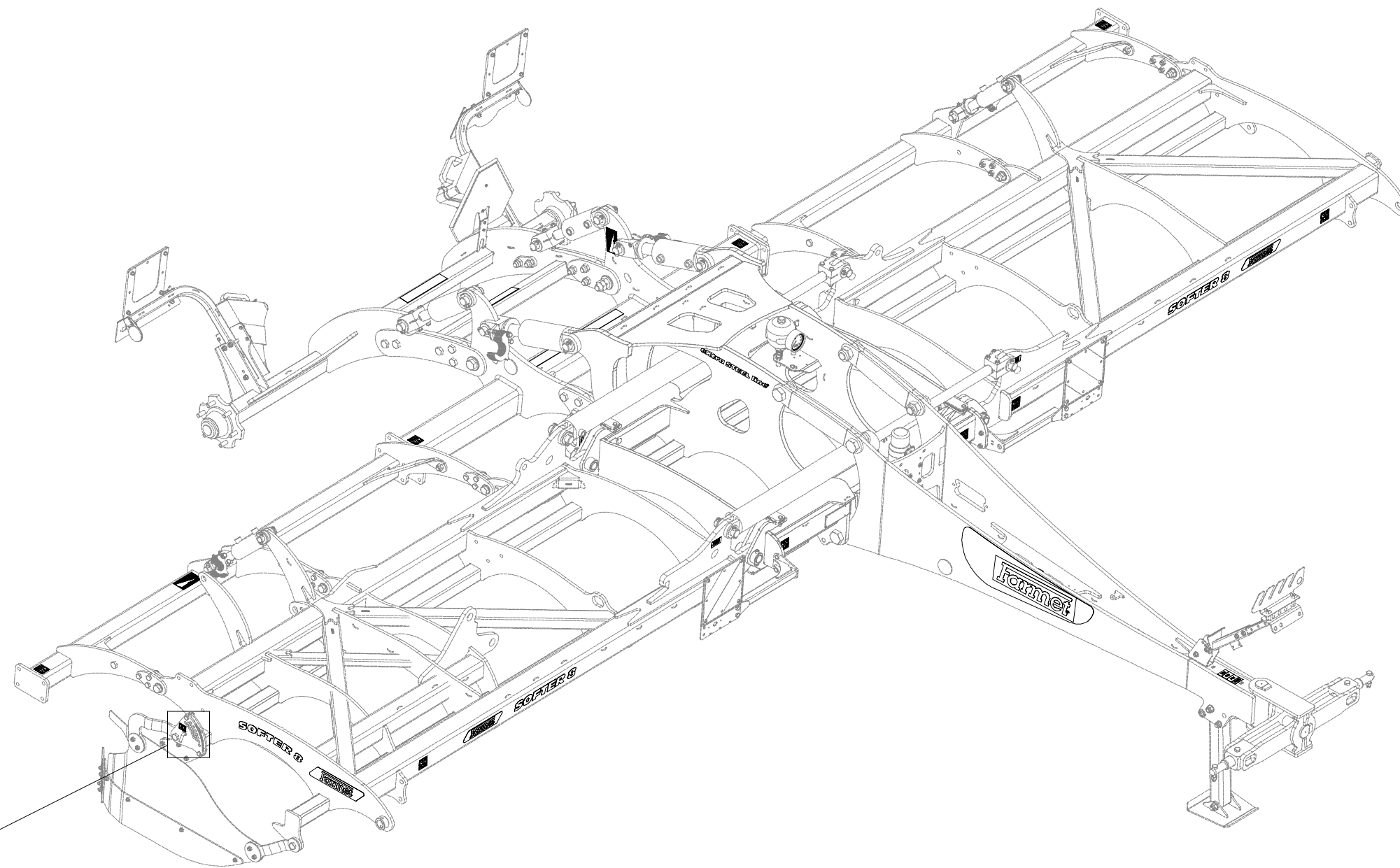

Pos.	Part Number	Pcs.
22	m22872	1

m24227

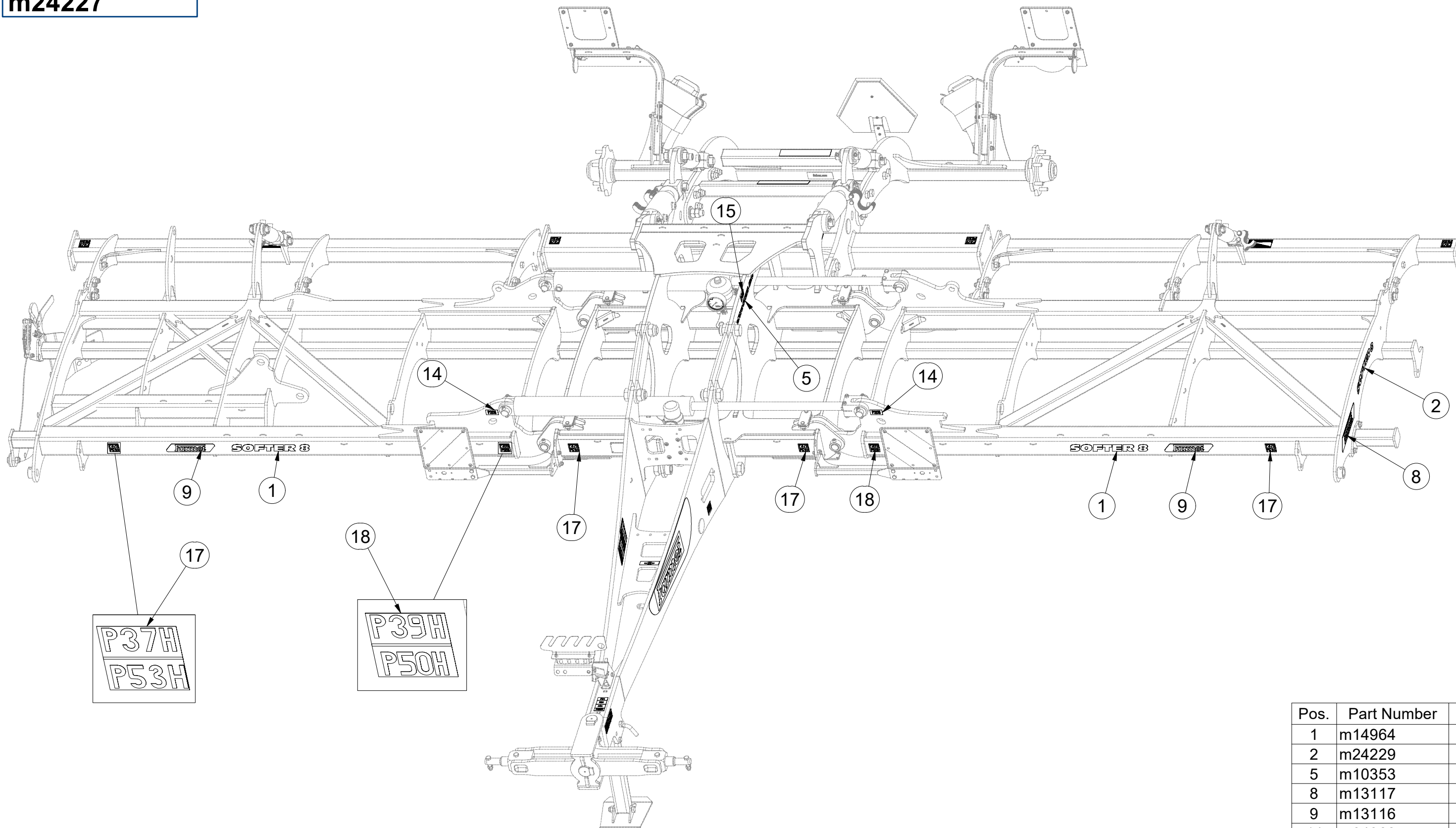

Pos.	Part Number	Pcs.
1	m14964	5
2	m24229	2
5	m10353	2
8	m13117	2
9	m13116	5
14	m04368	4
15	m05312	1
17	m11297	8
18	m11296	2

☉ SAMOLEPKY STROJE

☉ AUFKLEBER MASCHINEN

☉ VOITURE MACHINES

☉ STICKERS MACHINES

☉ СТИКЕРЫ МАШИНЫ

☉ NAKLEJKI MASZYNY



m24227

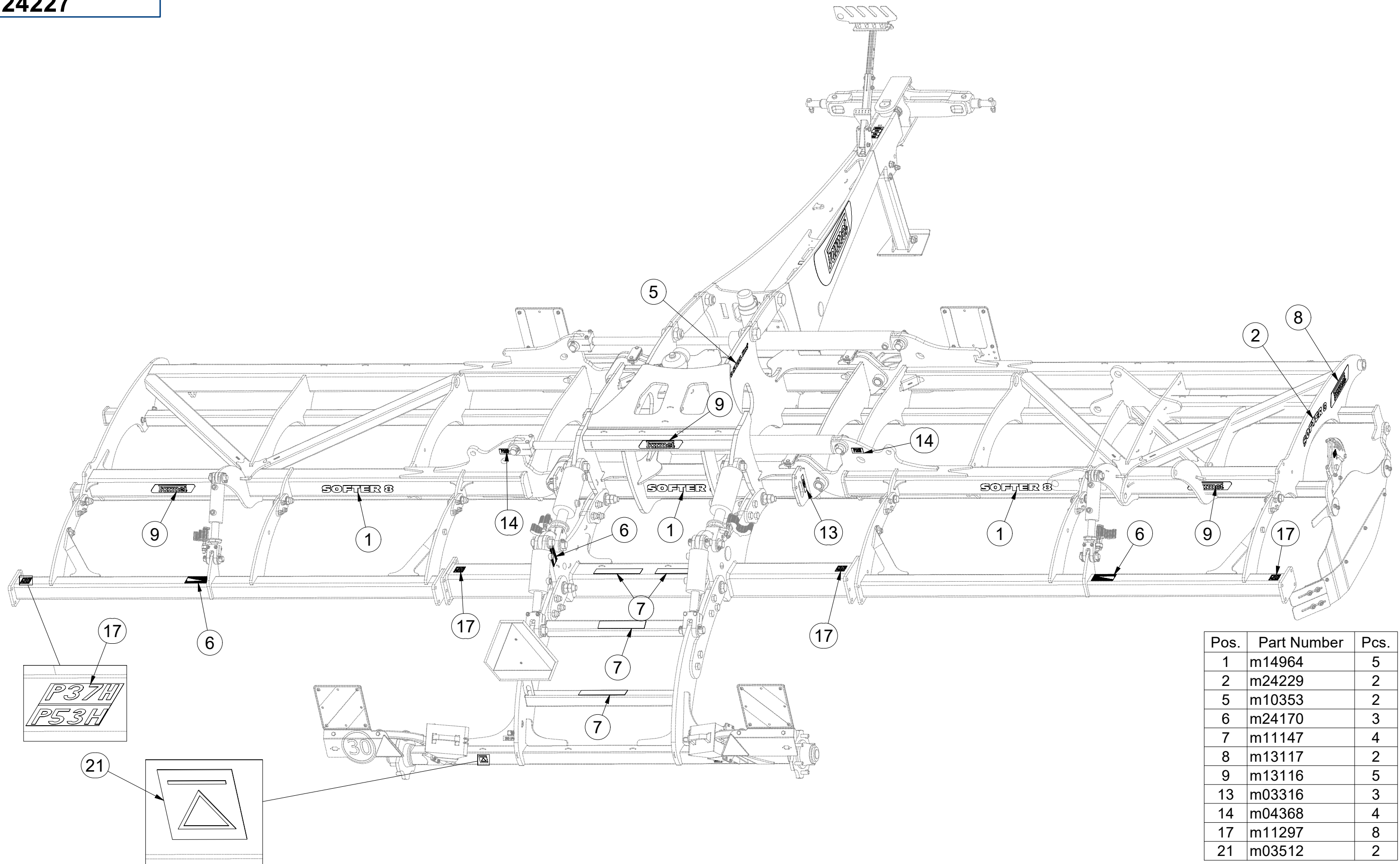

Pos.	Part Number	Pcs.
1	m14964	5
2	m24229	2
5	m10353	2
6	m24170	3
7	m11147	4
8	m13117	2
9	m13116	5
13	m03316	3
14	m04368	4
17	m11297	8
21	m03512	2

☉ SAMOLEPKY STROJE

☉ AUFKLEBER MASCHINEN

☉ VOITURE MACHINES

☉ STICKERS MACHINES

☉ СТИКЕРЫ МАШИНЫ

☉ NAKLEJKI MASZYNY



m24227

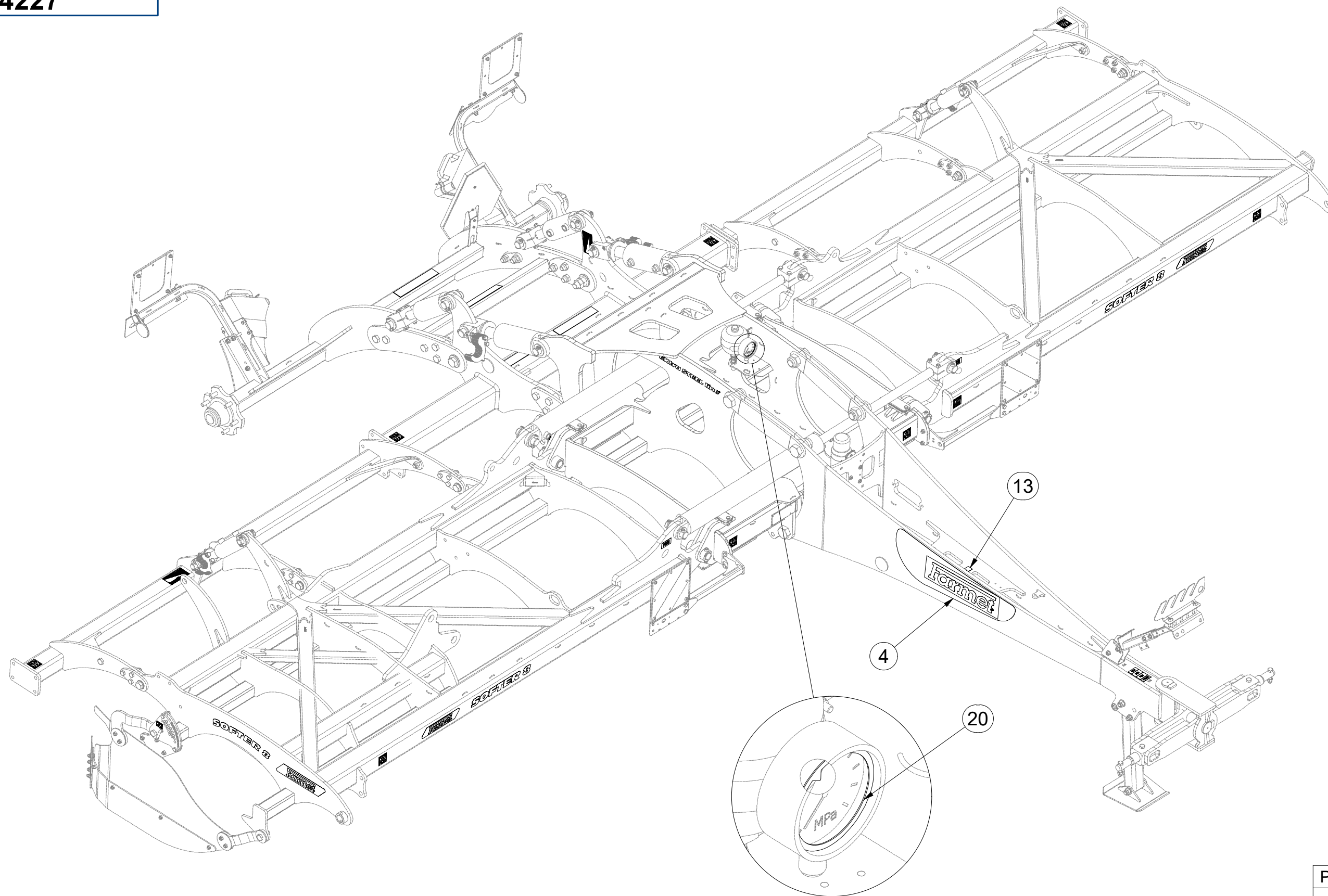

Pos.	Part Number	Pcs.
4	m13102	1
13	m03316	3
20	m17300	1

m24227

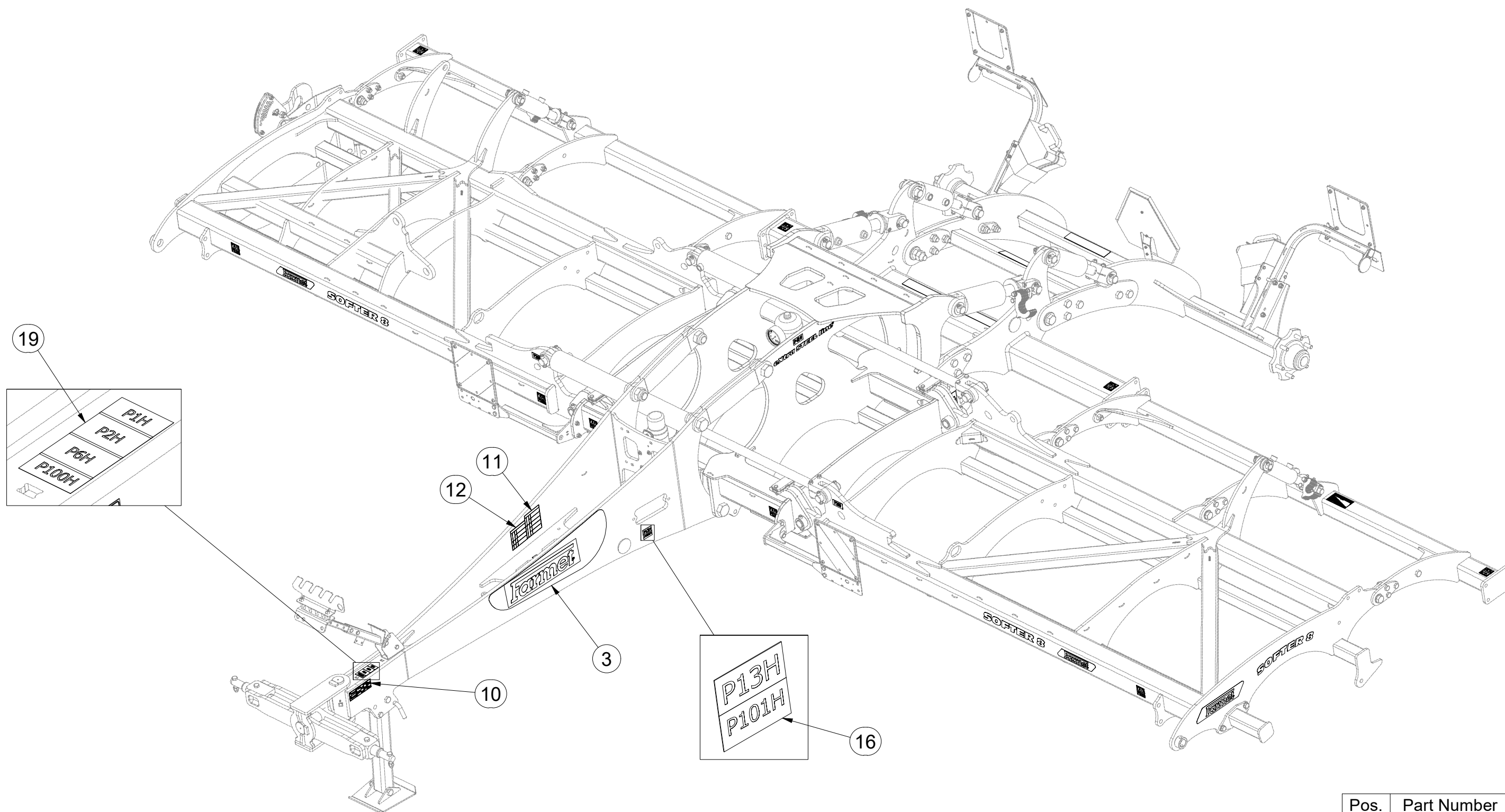

Pos.	Part Number	Pcs.
3	m13101	1
10	m21969	1
11	m11788	1
12	m11787	1
16	m11299	1
19	m11295	1

Ⓒ SAMOLEPKY STROJE

Ⓓ AUFKLEBER MASCHINEN

Ⓕ VOITURE MACHINES

Ⓖ STICKERS MACHINES

Ⓡ СТИКЕРЫ МАШИНЫ

Ⓟ NAKLEJKI MASZYNY



4025230

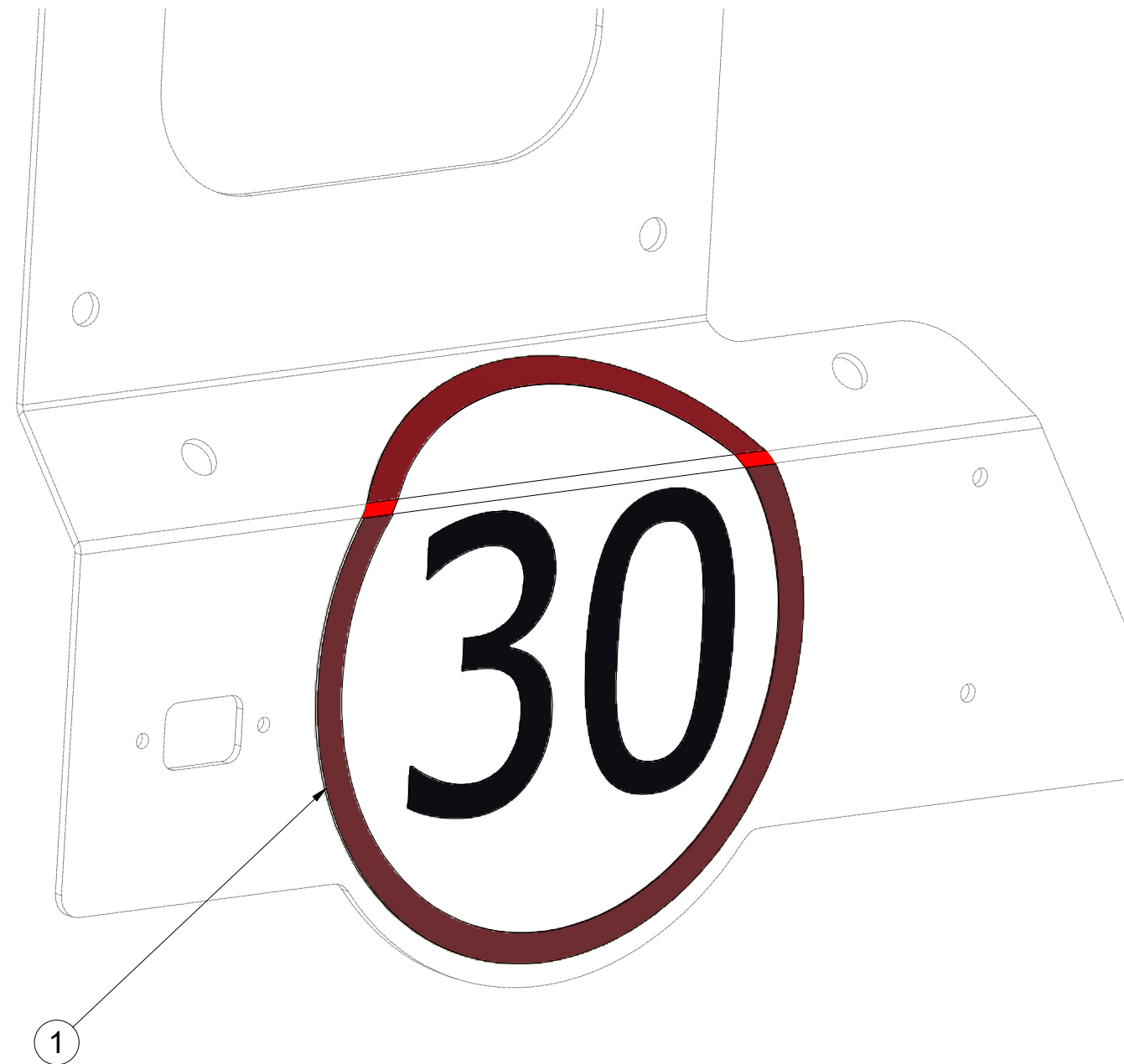

Pos.	Part Number	Pcs.
1	m19161	1

Ⓒ SVĚTELNÁ SADA

Ⓓ LEUCHTENSATZ

Ⓕ KIT LUMINEUX

Ⓖ LIGHTING SET

Ⓡ ОСВЕТИТЕЛЬНЫЙ КОМПЛЕКТ

Ⓟ ZESTAW OŚWIETLENIA



3012492

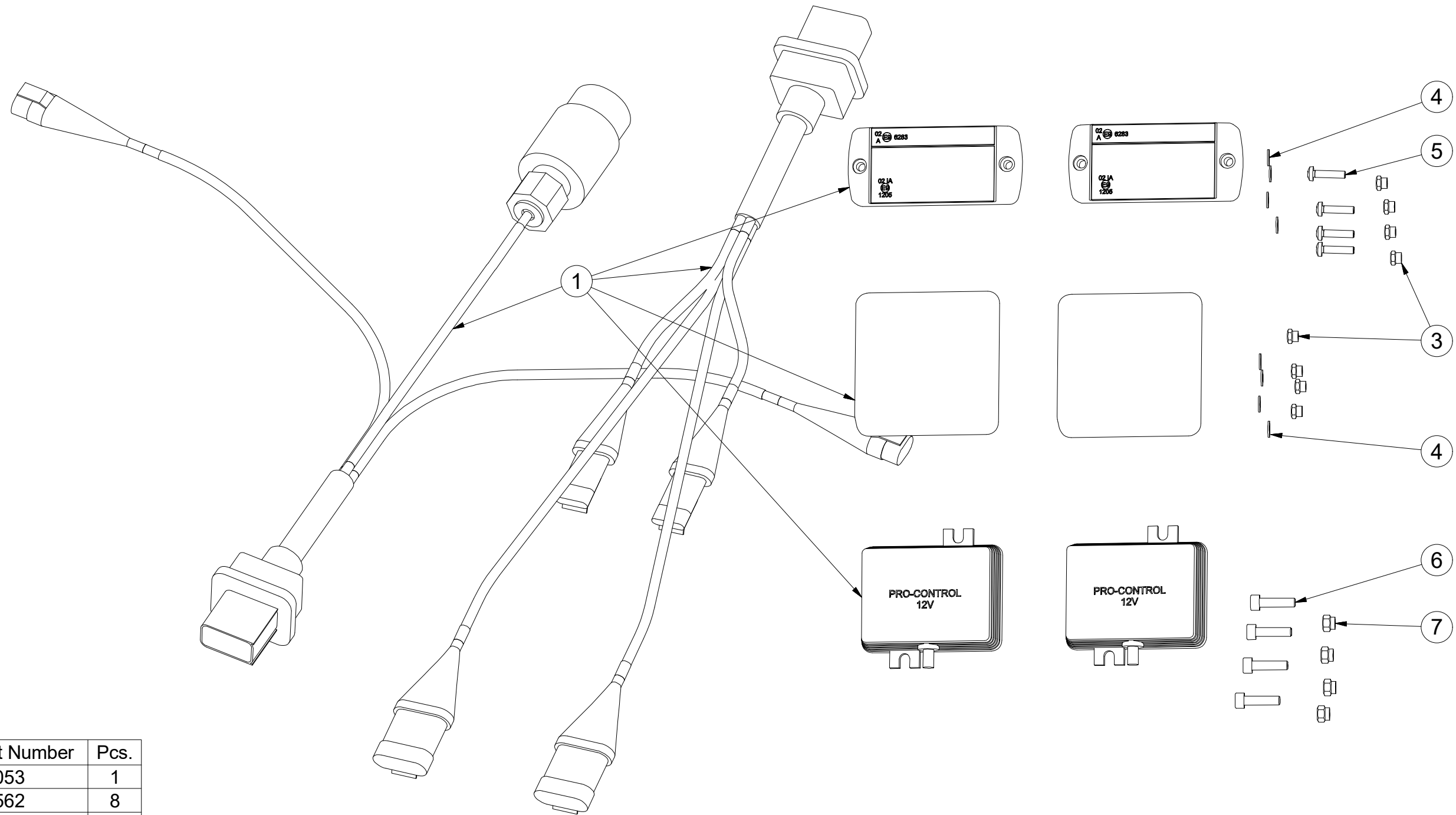

Pos.	Part Number	Pcs.
1	m19053	1
3	m05562	8
4	m05597	8
5	m15790	4
6	m10591	4
7	m06236	4

Ⓒ SVĚTELNÁ SADA

Ⓓ LEUCHTENSATZ

Ⓕ KIT LUMINEUX

m19053

Ⓖ LIGHTING SET

Ⓡ ОСВЕТИТЕЛЬНЫЙ КОМПЛЕКТ

Ⓟ ZESTAW OŚWIETLENIA

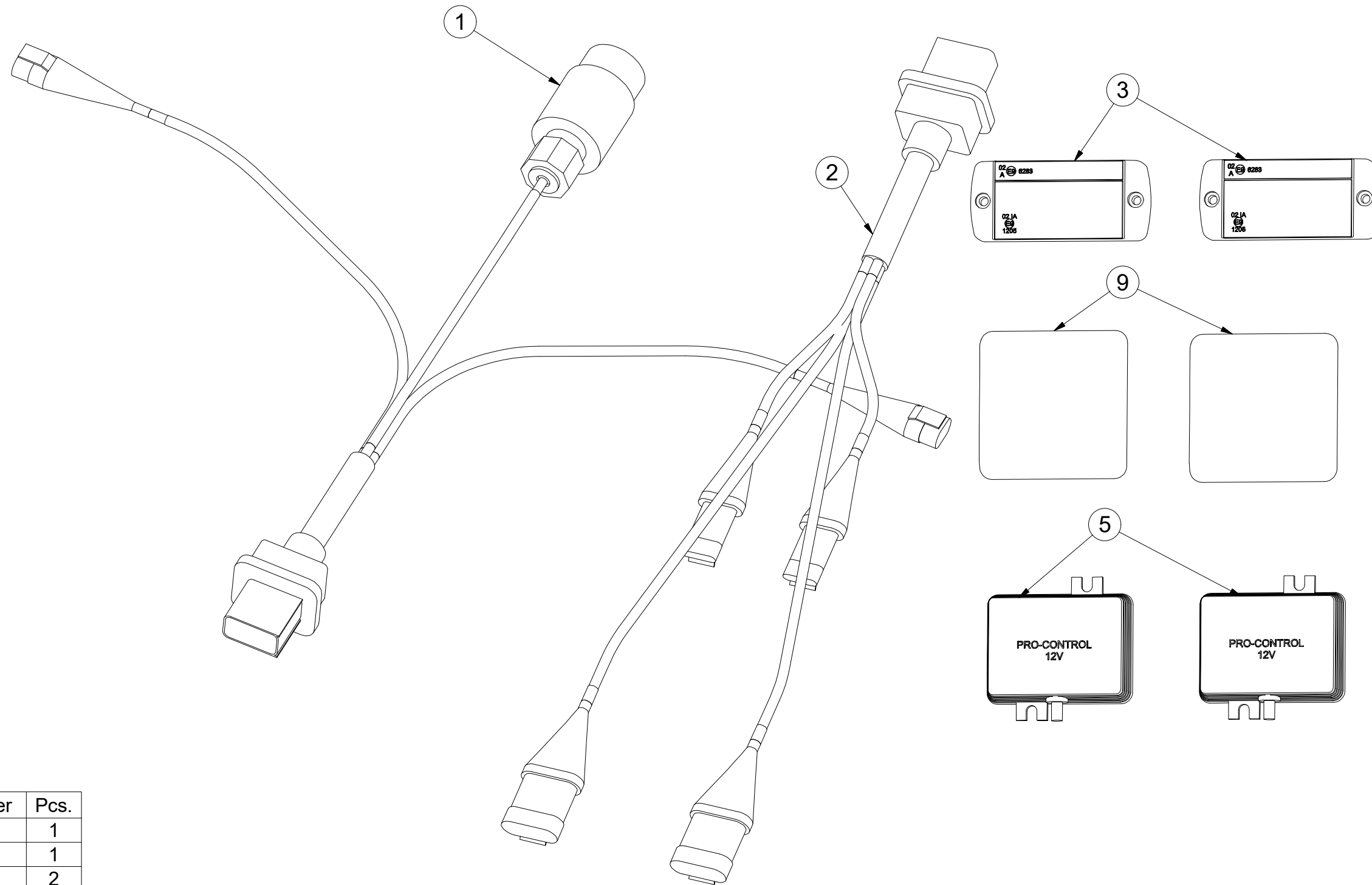

Pos.	Part Number	Pcs.
1	m14779	1
2	m14778	1
3	m14776	2
5	m14777	2
9	m19044	2

- Ⓒ UTAHOVACÍ MOMENTY ŠROUBŮ
 Ⓓ ANZUGMOMENTE VON SCHRAUBEN
 Ⓕ COUPLES DE SERRAGE DES VIS

- Ⓖ SCREW TIGHTENING TORQUE
 Ⓔ МОМЕНТЫ ЗАЖАТИЯ БОЛТОВ
 Ⓗ MOMENTY DOKRĘCANIA ŚRUB



P		5.8	8.8	10.9	12.9	Z	
D	R	Mu	Mu	Mu	Mu	DIN 7991	ISO 10642
mm	mm	Nm	Nm	Nm	Nm	Nm	Nm
M6	1	6	9	13	15	7,2	7,9
M8	1,25	14	22	32	38	17	19
M10	1,5	29	44	64	75	35	38
M12	1,75	49	76	111	130	58	65
M14	2	79	120	176	206	93	100
M16	2	123	188	276	323	144	158
M18	2,5	169	257	378	443	-	220
M20	2,5	239	365	536	628	-	310
M22	2,5	329	529	738	864	-	420
M24	3	413	629	924	1082	-	530
M27	3	613	934	1372	1606	-	-
M30	3,5	832	1267	1862	2179	-	-
M33	3,5	1130	1723	2530	2961	-	-
M36	4	1451	2210	3246	3799	-	-
M39	4	1885	2872	4217	4936	-	-
M42	4,5	2322	3538	5196	6080	-	-
M45	4,5	2909	4433	6511	7619	-	-
M48	5	3513	535	7862	9200	-	-
M52	5	4524	6895	10123	11849	-	-
M56	5,5	5636	8589	12614	14761	-	-

- Mu - Ⓒ UTAHOVACÍ MOMENT
 Ⓓ ANZUGMOMENTE
 Ⓕ COUPLE DE SERRAGE
 Ⓖ TIGHTENING TORQUE
 Ⓔ МОМЕНТ ЗАЖАТИЯ
 Ⓗ MOMENT DOKRĘCANIA
- D - Ⓒ JMENOVITÝ PRŮMĚR
 Ⓓ NENNDURCHMESSER
 Ⓕ DIAMETRE NOMINAL
 Ⓖ NOMINAL DIAMETER
 Ⓔ НОМИНАЛЬНЫЙ ДИАМЕТР
 Ⓗ ŚREDNICA NOMINALNA
- R - Ⓒ ROZTEČ ZÁVITU - STOUPÁNÍ
 Ⓓ GEWINDESTEIGUNG
 Ⓕ PAS DE FILET - PAS
 Ⓖ SCREW PITCH – LEAD
 Ⓔ ШАГ РЕЗЬБЫ
 Ⓗ ROZSTAW GWINTU - SKOKI
- P - Ⓒ PEVNOST
 Ⓓ FESTIGKEIT
 Ⓕ RÉSISTANCE
 Ⓖ STRENGTH
 Ⓔ ПРОЧНОСТЬ
 Ⓗ WYTRZYMA OŚĆ
- Z - Ⓒ ZÁPUSTNÉ ŠROUBY
 Ⓓ SENKKOPFSCHRAUBEN
 Ⓕ VIS A TETE FRAISEE
 Ⓖ COUNTERSUNK SCREWS
 Ⓔ БОЛТЫ С УТОПЛЕННОЙ ГОЛОВКОЙ
 Ⓗ ŚRUBY Z ŁBEM STOŻKOWYM PŁASKIM

- Ⓒ Hodnoty momentů jsou poníženy o -10% oproti tabulkovým hodnotám. Šroubové spoje utahujte dle vyznačeného utahovacího momentu v dokumentaci. Pokud není utahovací moment v dokumentaci vyznačen, utahujte dle obecné tabulky. Pokud je v dokumentaci definován spoj šroubu a matice o různých pevnostech, vždy utahujte na moment komponenty nižší.
- Ⓓ Die Werte der Anzugsmomente sind um 10 % gegenüber den Tabellenwerten verringert. Ziehen Sie die Schraubverbindungen gemäß dem in der Dokumentation festgeschriebenen Anzugsmoment an. Sofern das Anzugsmoment nicht in der Dokumentation aufgeführt ist, ziehen Sie sie gemäß der allgemeinen Tabelle an. Wenn in der Dokumentation eine Verbindung von Schraube und Mutter mit verschiedene Festigkeiten definiert ist, wird immer mit dem Moment des Bauteils mit der geringeren Festigkeit angezogen.
- Ⓕ Les valeurs des couples de serrage sont baissées de 10% par rapport aux valeurs de tableau. Serrez les raccords à vis selon le couple de serrage indiqué dans les documents. Si le couple de serrage n'est pas indiqué dans les documents, serrez selon le tableau général. Si les documents définissent un assemblage par boulon de diverses résistances, serrez toujours au moment de la composante avec résistance inférieure.
- Ⓖ The torque values are reduced by 10% compared to the table values. Tighten the screw joints according to the tightening torque stated in the documentation. If the tightening torque is not stated in the documentation, tighten according to the general table. If there is a joint with a screw and a nut at different strengths in the documentation, always tighten to the torque of the component with lower strength.
- Ⓔ Значения моментов затяжки уменьшены на 10% по сравнению с данными в таблице. Резьбовые соединения зажимайте с установленным в документации моментом зажатия. Если в документации не указан момент зажатия, то зажимайте по действующей в общем таблице. Если в документации установлено соединение из болта и гайки различной прочности, всегда зажимайте с моментом для компонента с меньшей прочностью.
- Ⓗ Wartości momentów dokręcania są obniżone o 10% w stosunku do wartości z tabeli. Połączenia śrubowe należy dokręcać zgodnie z momentem obrotowym w dokumentacji. Jeśli w dokumentacji nie ma podanego momentu obrotowego, należy dokręcać zgodnie z ogólną tabelą. Jeśli w dokumentacji zdefiniowane jest połączenie ze śrubą nakrętką różnych wytrzymałościach, zawsze należy dokręcać zachowując moment dokręcania komponentu z niższą wytrzymałością.

- Ⓒ UTAHOVACÍ MOMENTY ŠROUBŮ
 Ⓓ ANZUGMOMENTE VON SCHRAUBEN
 Ⓕ COUPLES DE SERRAGE DES VIS

- Ⓖ SCREW TIGHTENING TORQUE
 Ⓡ MOMENTЫ ЗАЖАТИЯ БОЛТОВ
 Ⓟ MOMENTY DOKRĘCANIA ŚRUB



- Ⓒ **OBECNÝ PŘEDPIS UTAHOVÁNÍ ZAJIŠTĚNÍ ČEPOVÝCH SPOJŮ:**
 Ⓓ **ALLGEMEINE VORSCHRIFT FÜR DAS ANZIEHEN VON BOLZENVERBINDUNGEN:**
 Ⓕ **CONSIGNE GENERALE POUR LE SERRAGE DES ARTICULATIONS CYLINDRIQUES:**
 Ⓖ **GENERAL INSTRUCTION FOR TIGHTENING THE SECURING OF PIN JOINTS:**
 Ⓡ **ОБЩЕЕ ОПИСАНИЕ ЗАЖАТИЯ ПРЕДОХРАНЕНИЯ СОЕДИНЕНИЙ ПАЛЬЦАМИ:**
 Ⓟ **OGÓLNE ZASADY DOKRĘCANIA ZABEZPIECZENIA POŁĄCZEŃ CZOPEM:**



X

M8, M10, M12

M14

M

09-15Nm

15-25Nm

- X - Ⓒ ROZMĚR ŠROUBU
 Ⓓ SCHRAUBENGRÖSSE
 Ⓕ DIMENSIONS DE LA VIS

- Ⓖ BOLT DIMENSION
 Ⓡ РАЗМЕР БОЛТА
 Ⓟ ROZMIAR ŚRUBY

- M - Ⓒ ORIENTAČNÍ MOMENT
 Ⓓ ANZUGSMOMENT
 Ⓕ COUPLE D'ORIENTATION

- Ⓖ ORIENTATION TORQUE
 Ⓡ ОРИЕНТАЦИОННЫЙ МОМЕНТ
 Ⓟ ORIENTACYJNY MOMENT

- Ⓒ Tyto spoje není nutné ověřovat kontrolou momentovým klíčem = stačí vizuálně kontrolovat sešroubování.
 Ⓓ Diese Verbindungen müssen nicht mit einem Drehmomentschlüssel überprüft werden = es genügt, die Verschraubung visuell zu kontrollieren.
 Ⓕ Il n'est pas nécessaire de contrôler le serrage à l'aide d'une clé dynamométrique = un contrôle visuel de l'assemblage suffit.
 Ⓖ These joints do not have to be verified by checking with a torque wrench = visual inspection of bolting is sufficient.
 Ⓡ Эти соединения не нужно контролировать динамометрическим ключом = достаточно визуально проверять прикручивание.
 Ⓟ Nie trzeba sprawdzać tych połączeń kluczem dynamometrycznym = wystarczy wizualnie skontrolować dokręcenie.