

ⒸZ KATALOG NÁHRADNÍCH DÍLŮ ⒸB CATALOGUE OF SPARE PARTS ⒸD ERSATZTEILLISTE
ⒸRU КАТАЛОГ ЗАПАСНЫХ ЧАСТЕЙ ⒸF CATALOGUE DES PIÈCES DE RECHANGE ⒸPL KATALOG CZĘŚCI ZAMIENNYCH

SOFTER 5 PS

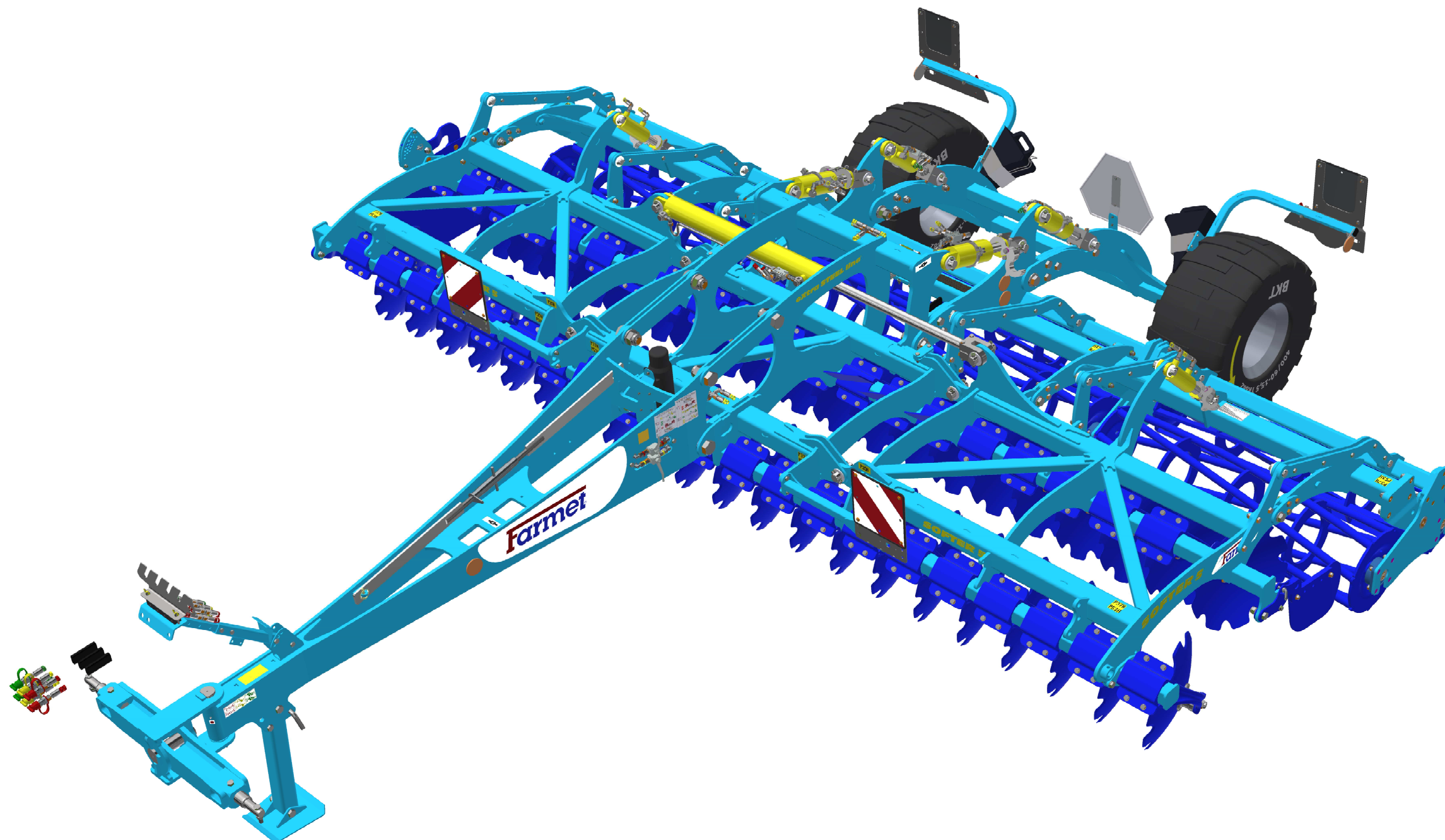

ⒸZ Platnost pro vrcholové | výrobní číslo stroje ⒸB Validity for the top | serial number of the machine
ⒸD Gültigkeit für die Haupt- | Herstellungsnummer der Maschine ⒸRU Действительно для главного | заводского номера машины
ⒸF Validité du numéro de référence | de série de la machine ⒸPL Obowiązuje dla numeru głównego | seryjnego maszyny

9336319 | 2024/0667

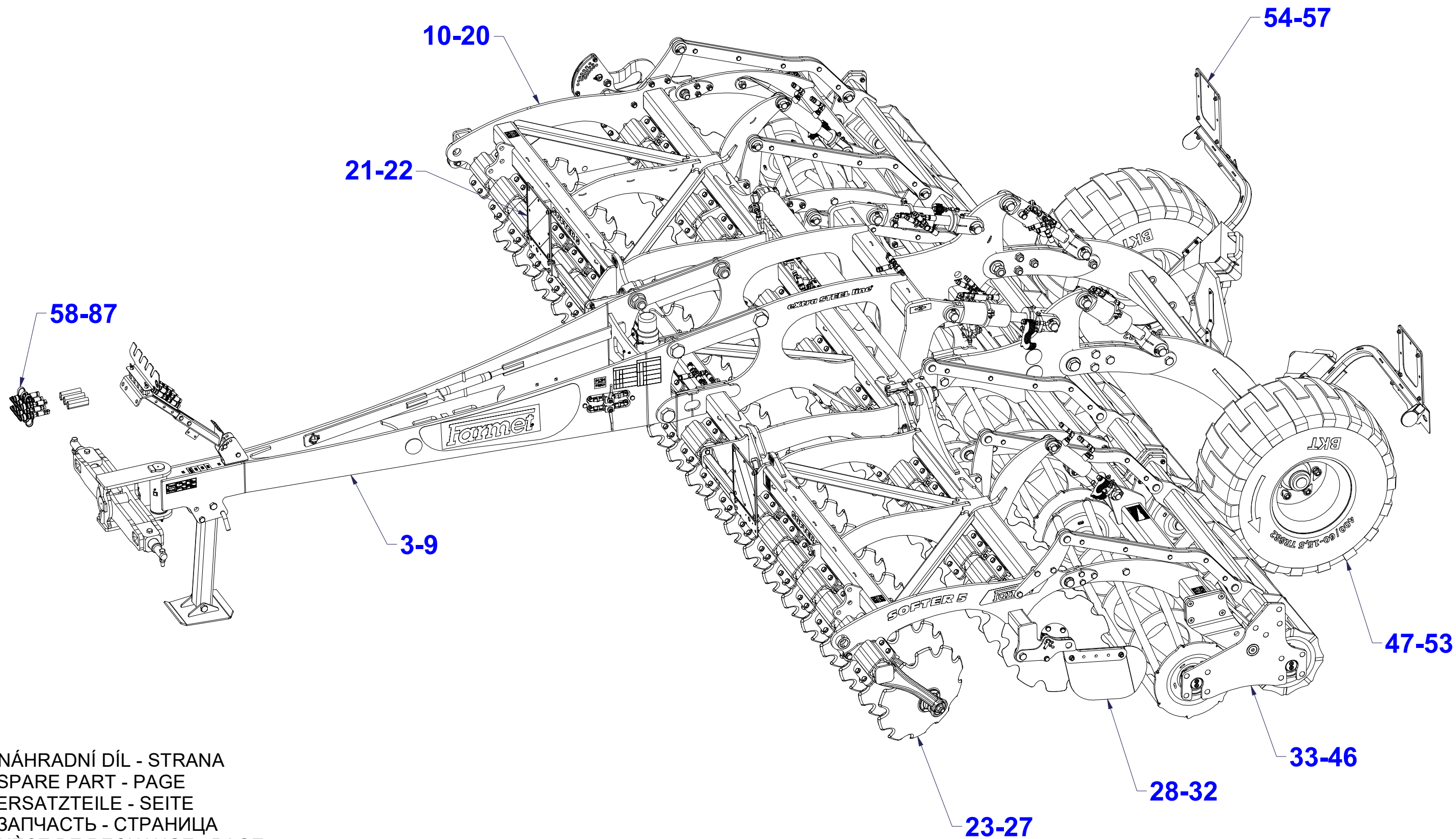

ⒸZ OJ MONT

Ⓓ DEICHSEL MONTIERT

Ⓕ TIMON MONTÉ

VZ00037087

ⒼB MONT DRAWBAR

ⒺU ДЫШЛО МОНТ

ⒽL DYSZEL MONT

Farmet

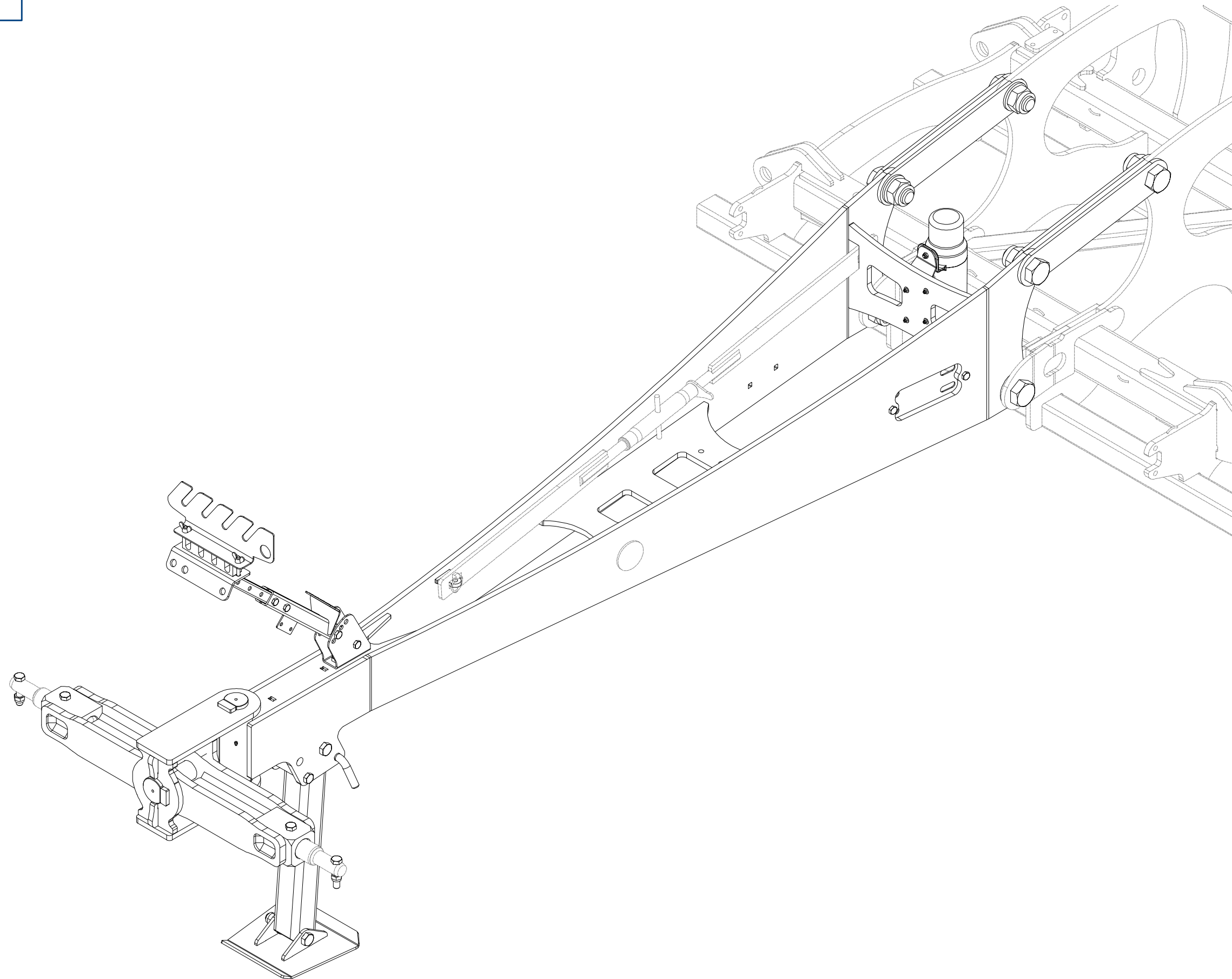

ⒸZ OJ MONT

Ⓓ DEICHSEL MONTIERT

Ⓕ TIMON MONTÉ

VZ00037087

ⒸB MONT DRAWBAR

ⒸR ДЫШЛО МОНТ

ⒸL DYSZEL MONT

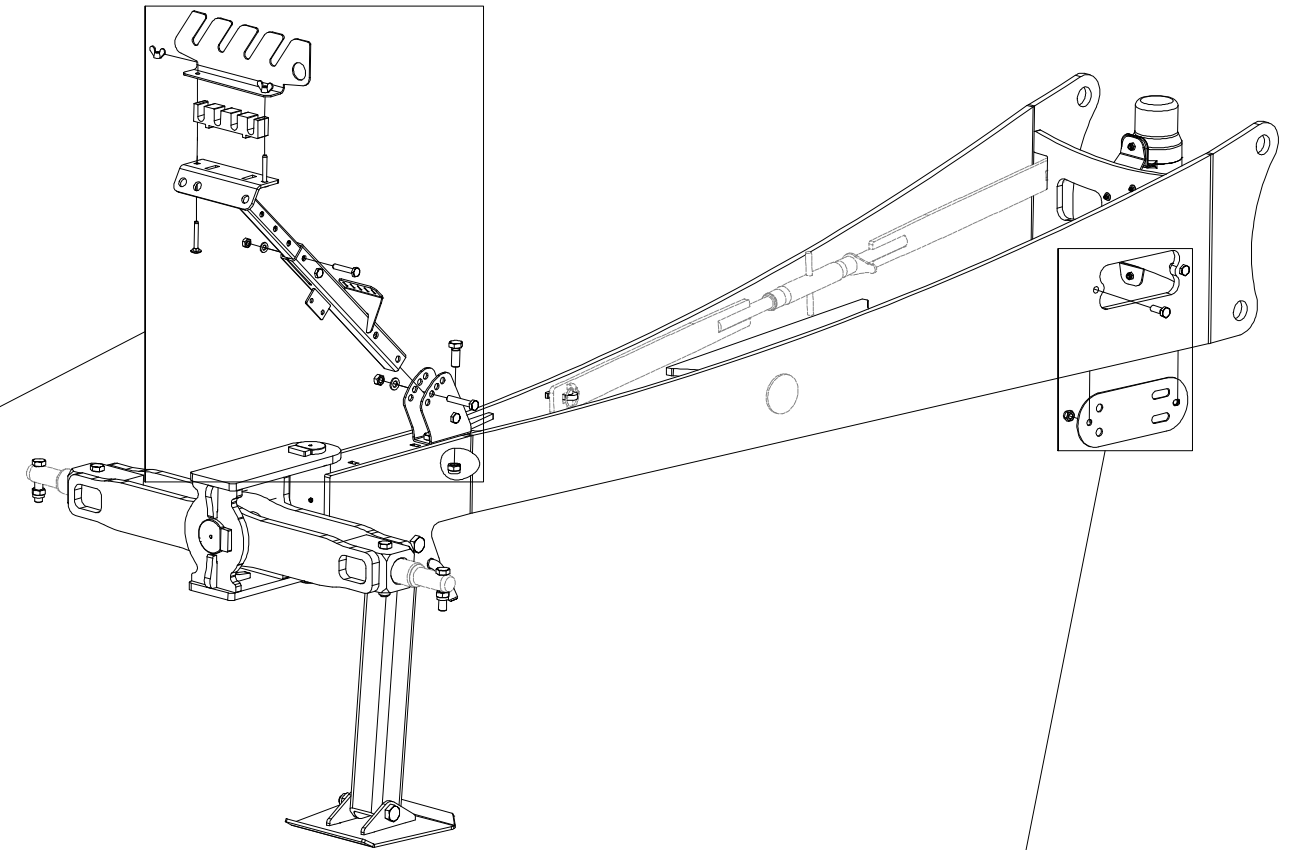
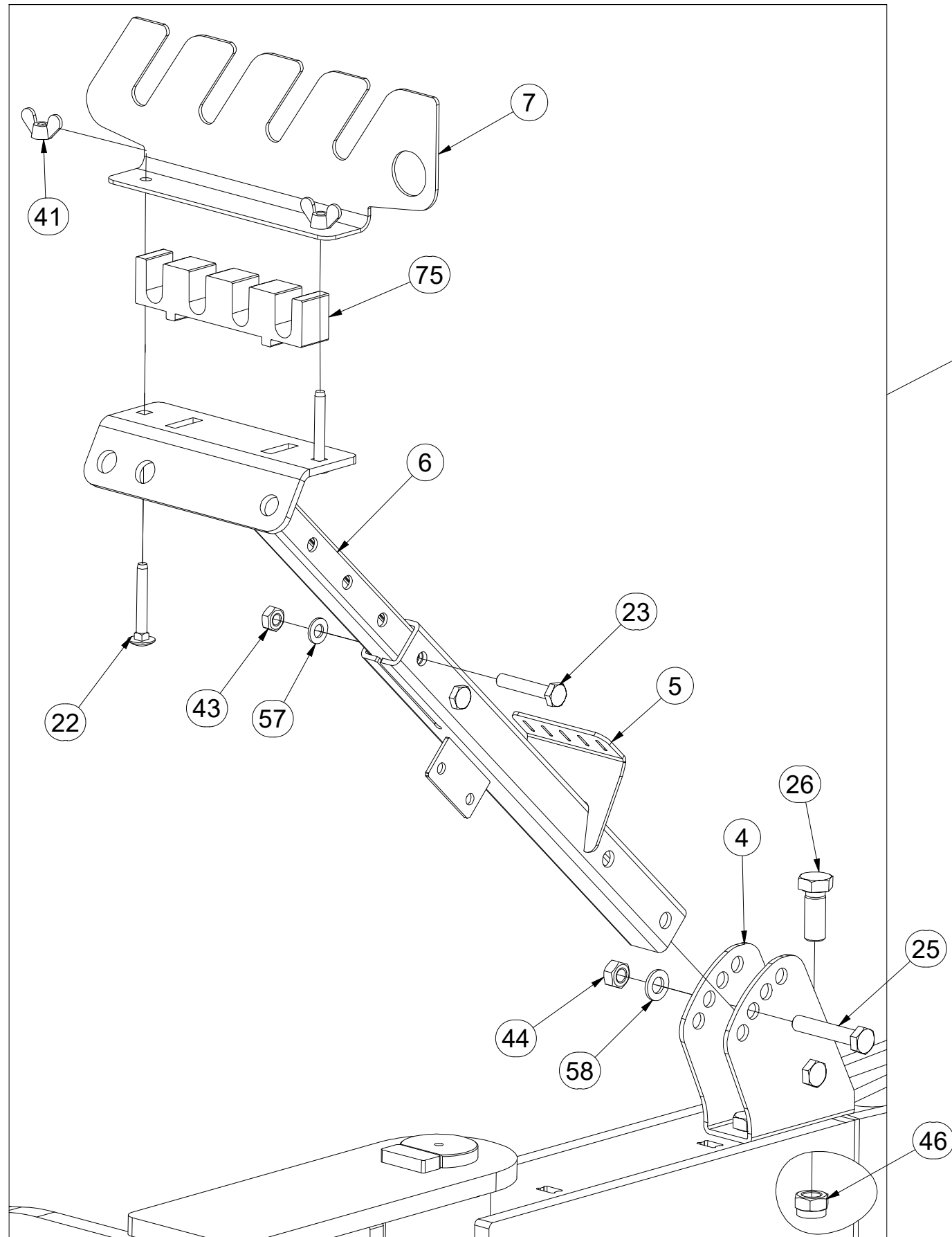

Pos.	Part Number	Pcs.
4	3011659	1
5	3011662	1
6	3011689	1
7	4023572	1
13	4025719	1
22	m09247	2
23	m06253	2
24	m04343	2
25	m05898	2
26	m01129	2
41	m01316	2
43	m01299	2
44	m01305	2
45	m04301	2
46	m03683	7
57	m01209	2
58	m01214	2
75	m22642	1

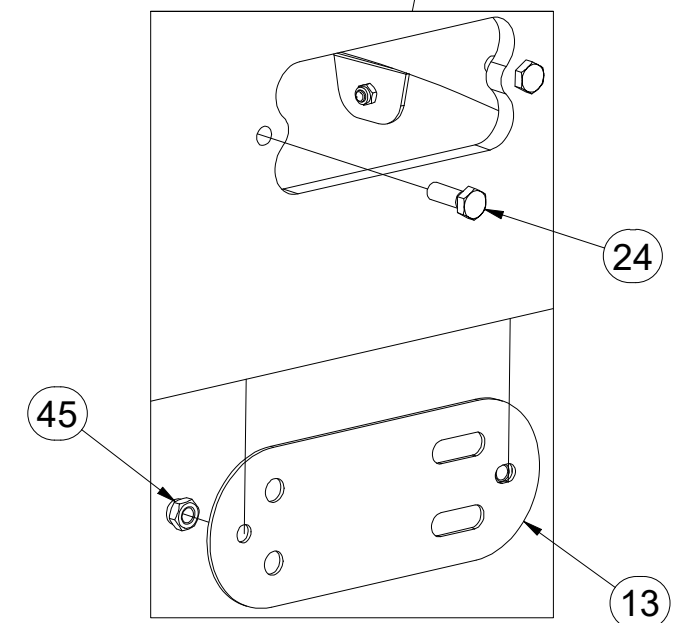

ⒸZ OJ MONT

Ⓓ DEICHSEL MONTIERT

Ⓕ TIMON MONTÉ

ⒼB MONT DRAWBAR

ⒺU ДЫШЛО МОНТ

ⒼL DYSZEL MONT



VZ00037087

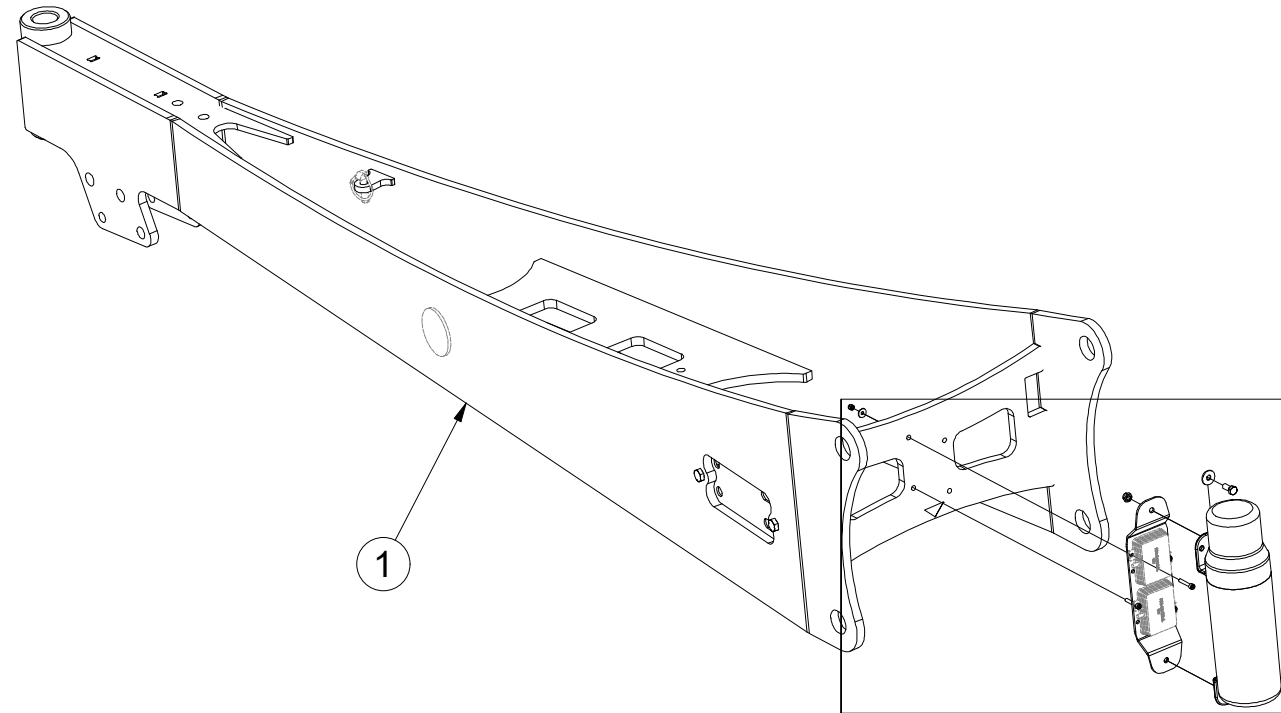

Pos.	Part Number	Pcs.
1	2001291	1
11	4017879	1
20	m10029	4
21	m01089	2
40	m06236	4
42	m04503	2
55	m10438	4
56	m07936	2
80	m15900	1

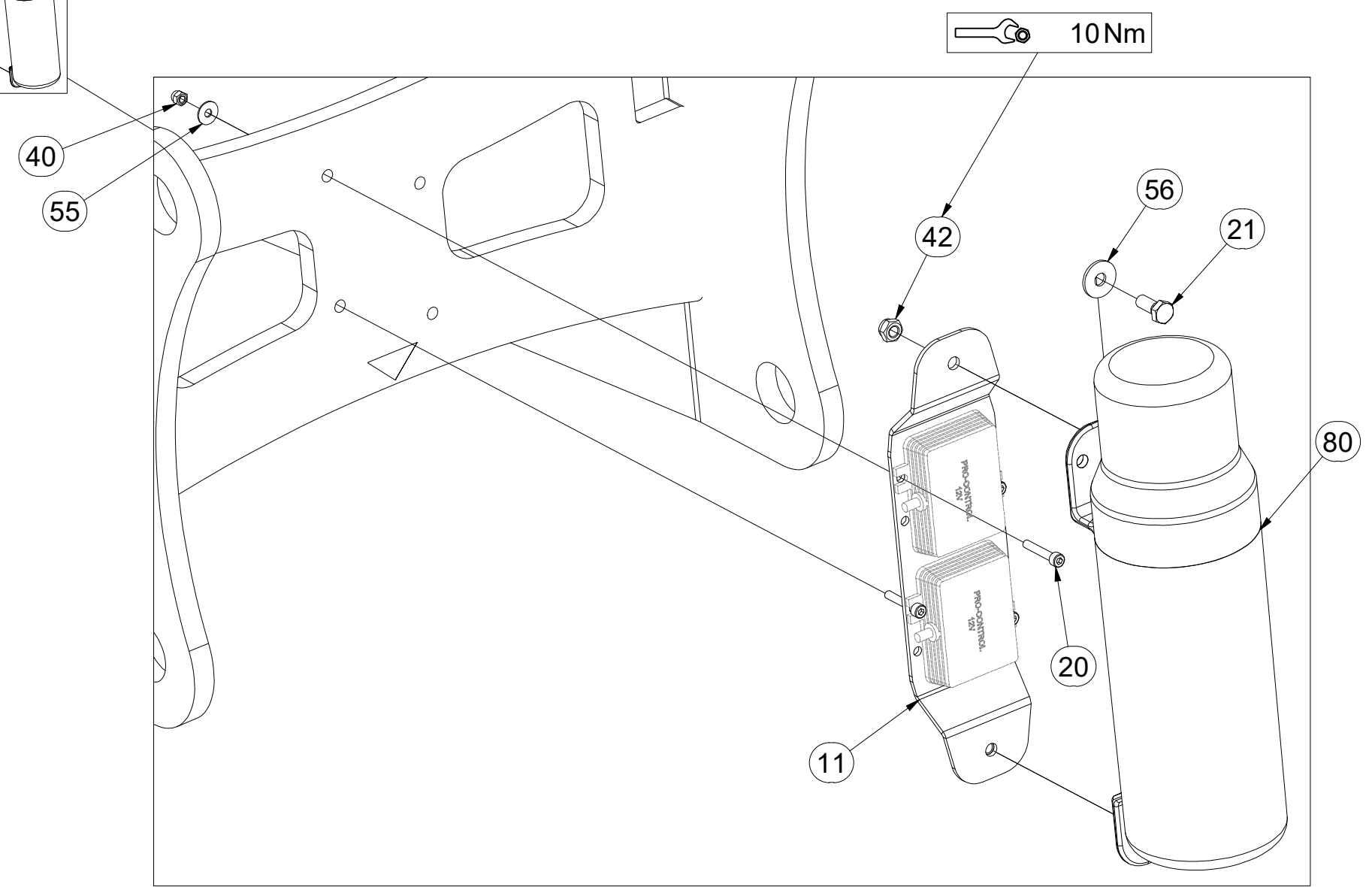

ⒸZ OJ MONT

Ⓓ DEICHSEL MONTIERT

Ⓕ TIMON MONTÉ

VZ00037087

ⒼB MONT DRAWBAR

Ⓔ RU ДЫШЛО МОНТ

Ⓗ PL DYSZEL MONT

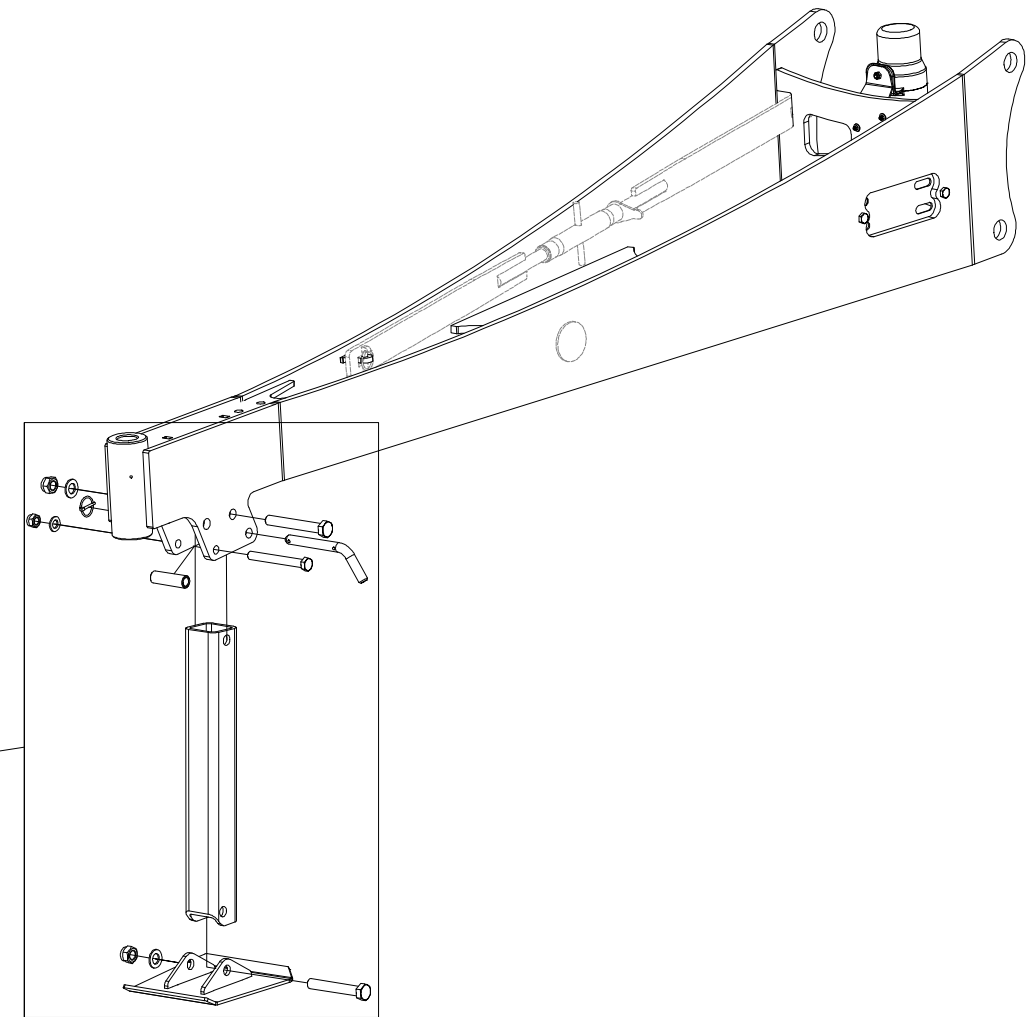
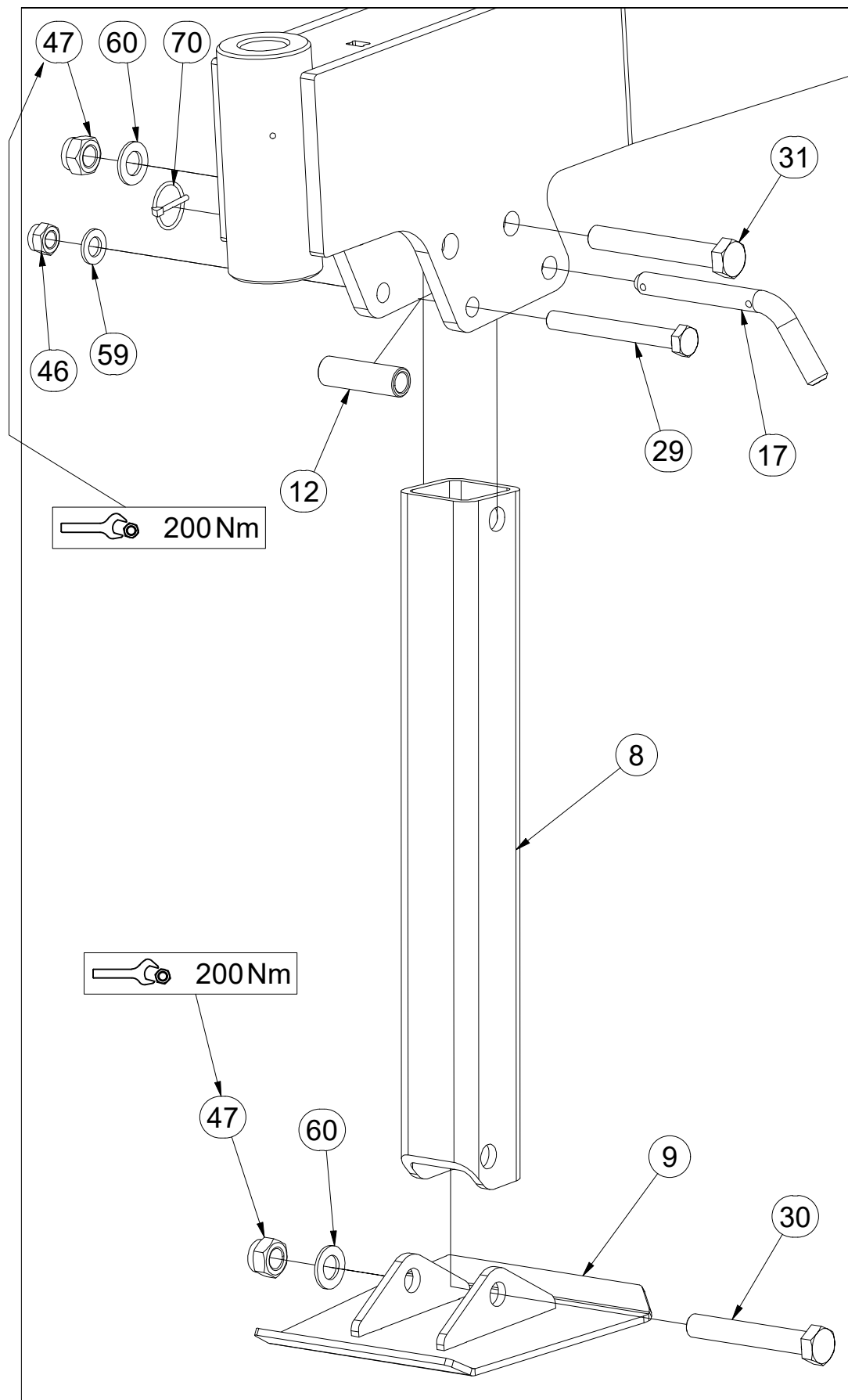

Pos.	Part Number	Pcs.
8	4006699	1
9	4007000	1
12	4004007	1
17	m08386	1
29	m06046	1
30	m05465	1
31	m07790	1
46	m03683	7
47	m05648	2
59	m01219	1
60	m03768	2
70	m10454	1

Ⓒ OJ MONT

Ⓓ DEICHSEL MONTIERT

Ⓕ TIMON MONTÉ

VZ00037087

Ⓖ MONT DRAWBAR

Ⓔ ДЫШЛО МОНТ

Ⓗ DYSZEL MONT

Farmet

Pos.	Part Number	Pcs.
10	4007828	4
32	m23664	6
49	m23663	6
62	VZ00004249	2
63	VZ00004252	2
64	VZ00004253	4
65	VZ00036554	4

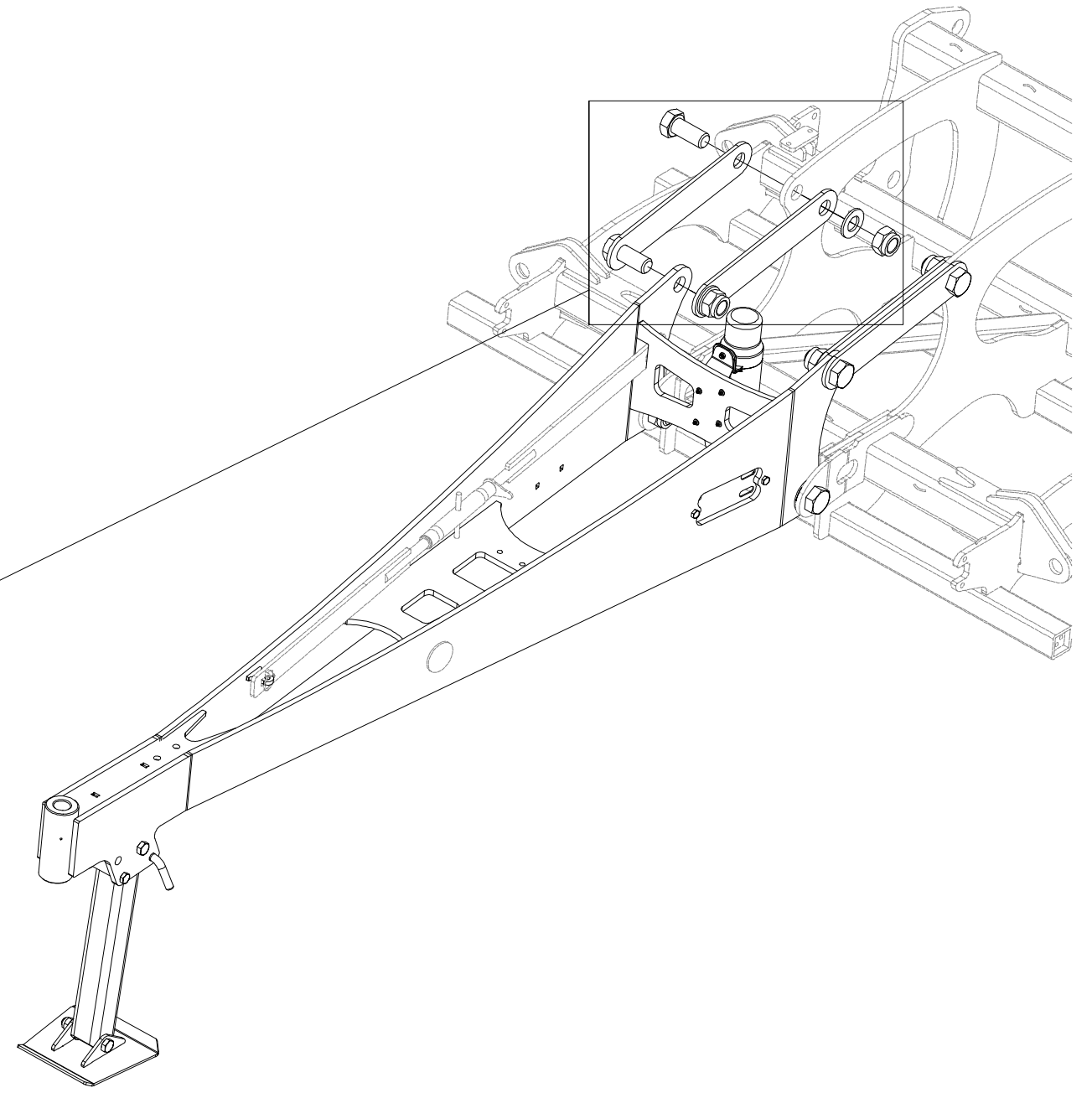
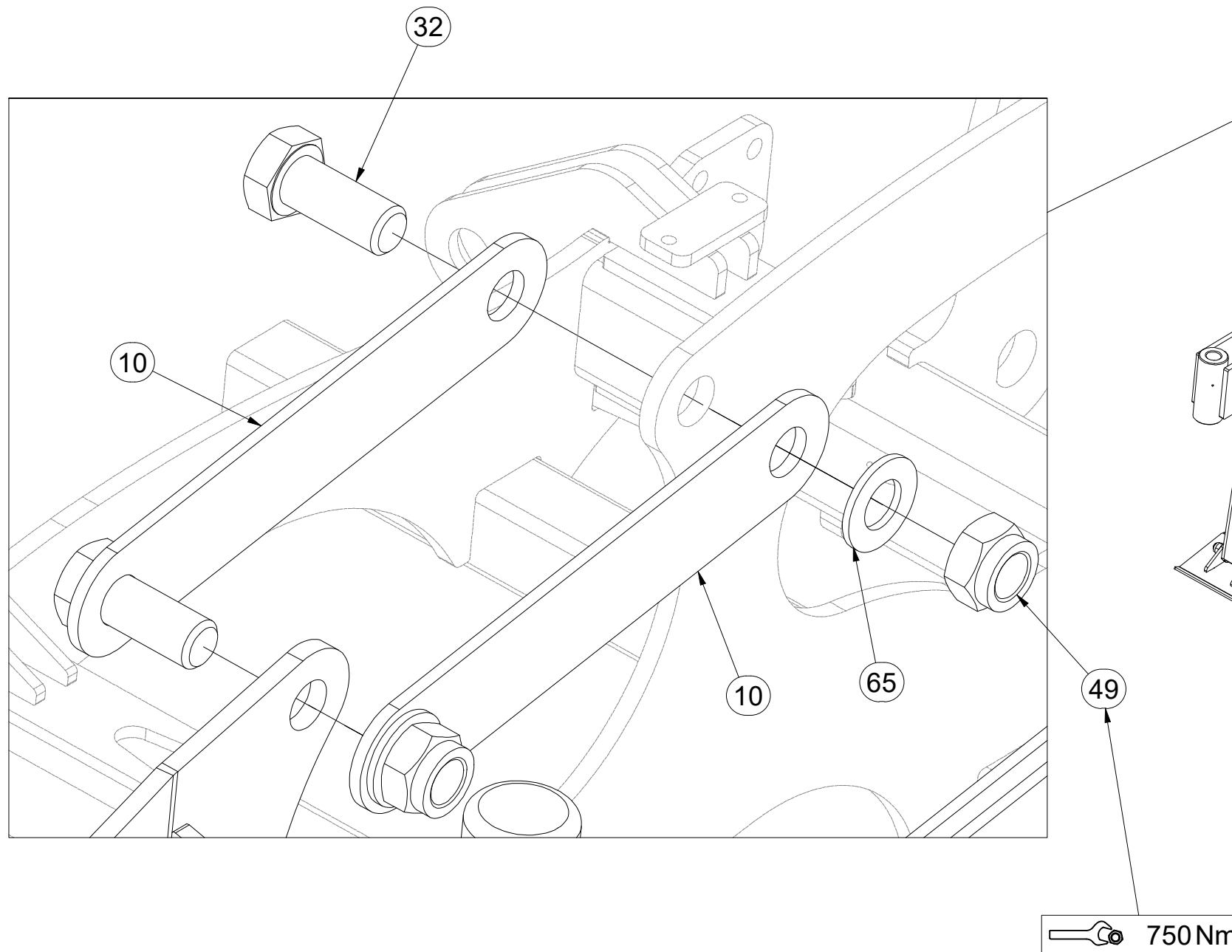

ⒸZ OJ MONT

Ⓓ DEICHSEL MONTIERT

Ⓕ TIMON MONTÉ

ⒼB MONT DRAWBAR

Ⓔ RU ДЫШЛО МОНТ

ⒼL DYSZEL MONT



VZ00037087

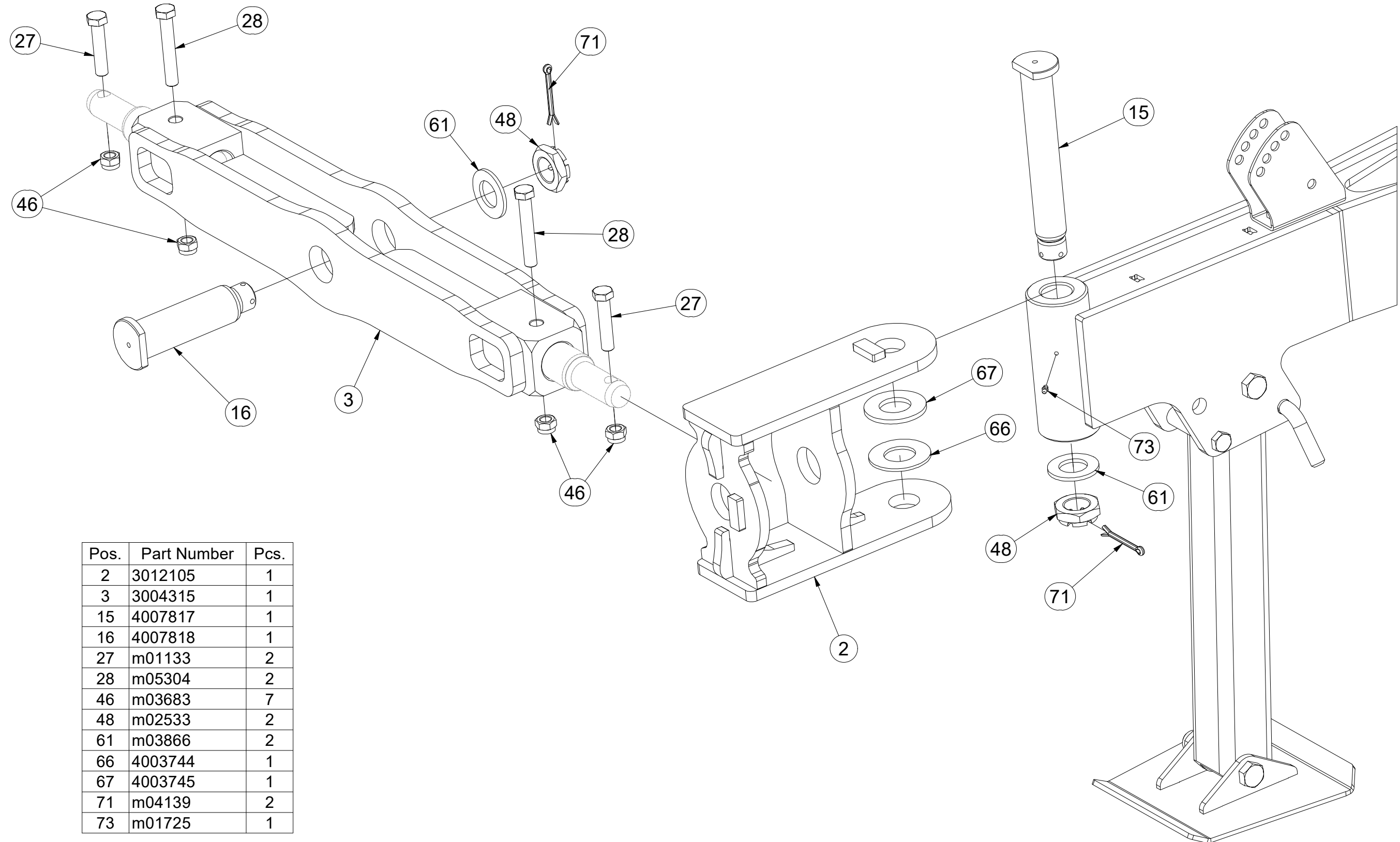

Pos.	Part Number	Pcs.
2	3012105	1
3	3004315	1
15	4007817	1
16	4007818	1
27	m01133	2
28	m05304	2
46	m03683	7
48	m02533	2
61	m03866	2
66	4003744	1
67	4003745	1
71	m04139	2
73	m01725	1

Ⓒ SADA ČEPŮ TBZ 3

Ⓓ BOLZENSATZ TBZ 3

Ⓕ KIT D'EMBOUITS TBZ 3

4020780

Ⓖ SET OF TBZ 3 PINS

Ⓡ КОМПЛЕКТ ПАЛЬЦЕВ TBZ 3

Ⓟ ZESTAW CZOPÓW TBZ 3

Farmet

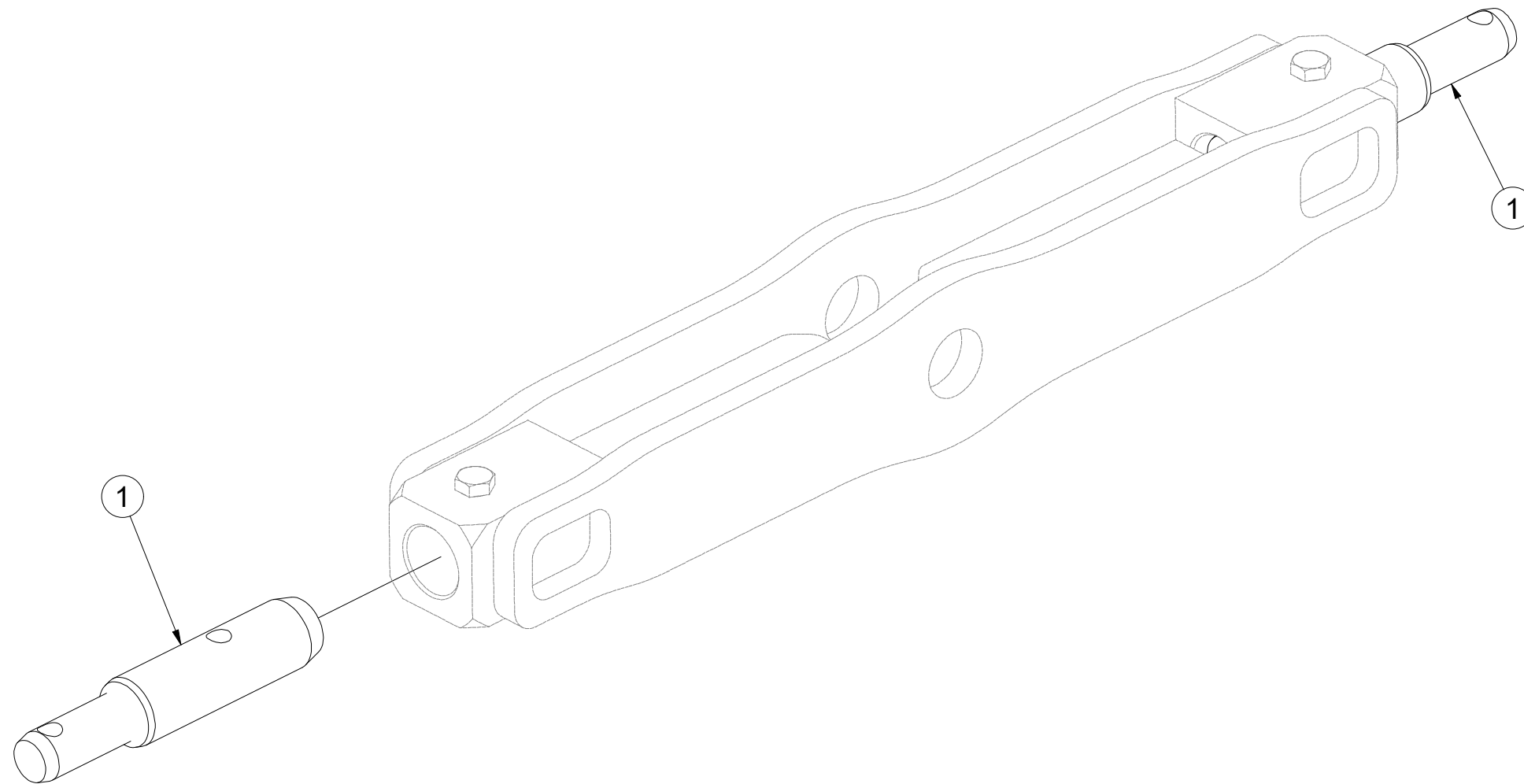

Pos.	Part Number	Pcs.
1	VZ00022883	2

Ⓒ ZÁKLAD STROJE

Ⓓ UNTERBAU DER MASCHINE

Ⓕ BÂTI DE LA MACHINE

VZ00036948

Ⓖ FOOTING OF THE MACHINE

Ⓡ ОСНОВАНИЕ МАШИНЫ

Ⓟ PODSTAWA MASZYNY

Farmet

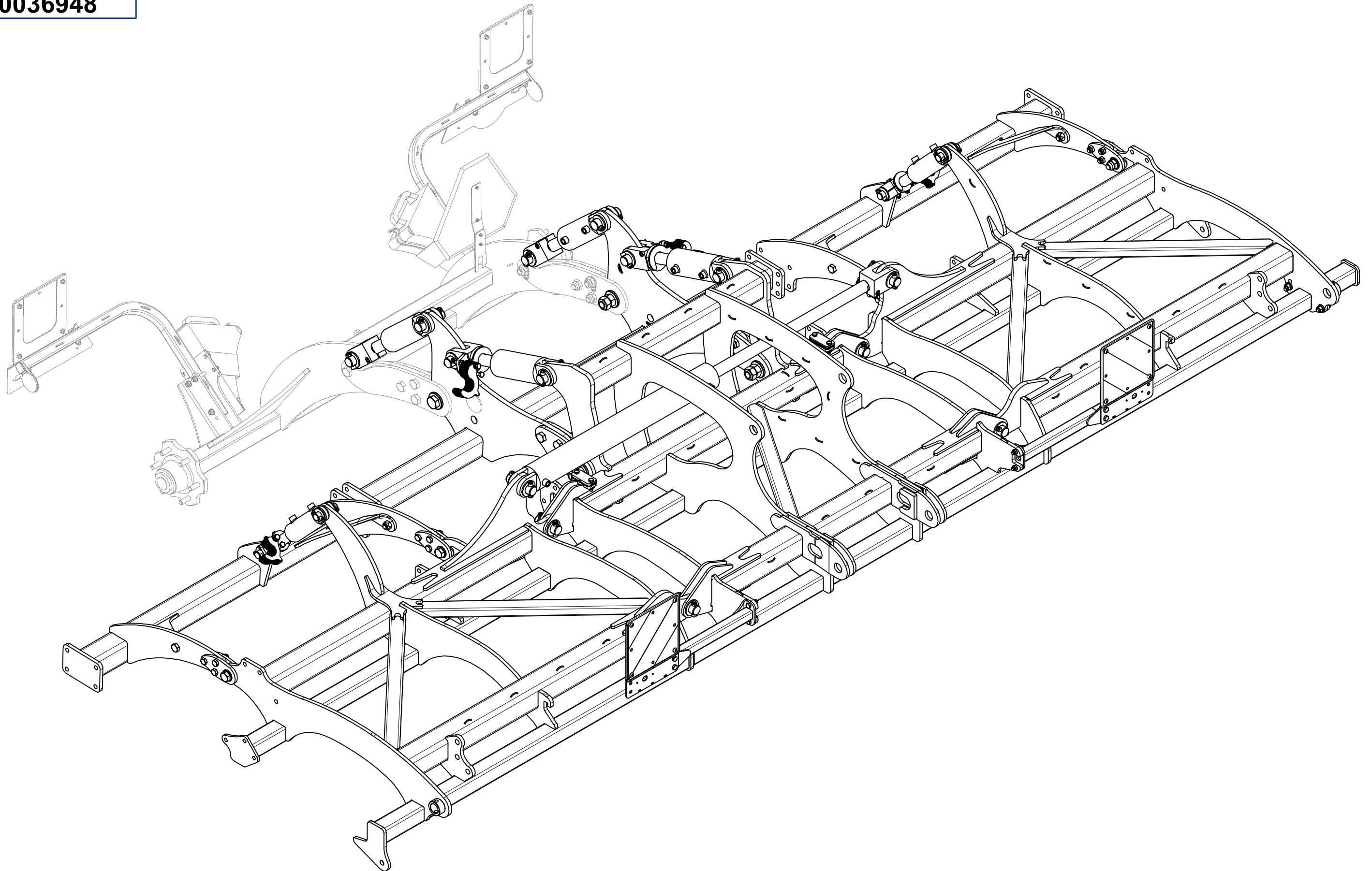

Ⓒ ZÁKLAD STROJE

Ⓓ UNTERBAU DER MASCHINE

Ⓕ BÂTI DE LA MACHINE

Ⓖ FOOTING OF THE MACHINE

Ⓡ ОСНОВАНИЕ МАШИНЫ

Ⓟ PODSTAWA MASZINY



VZ00036948

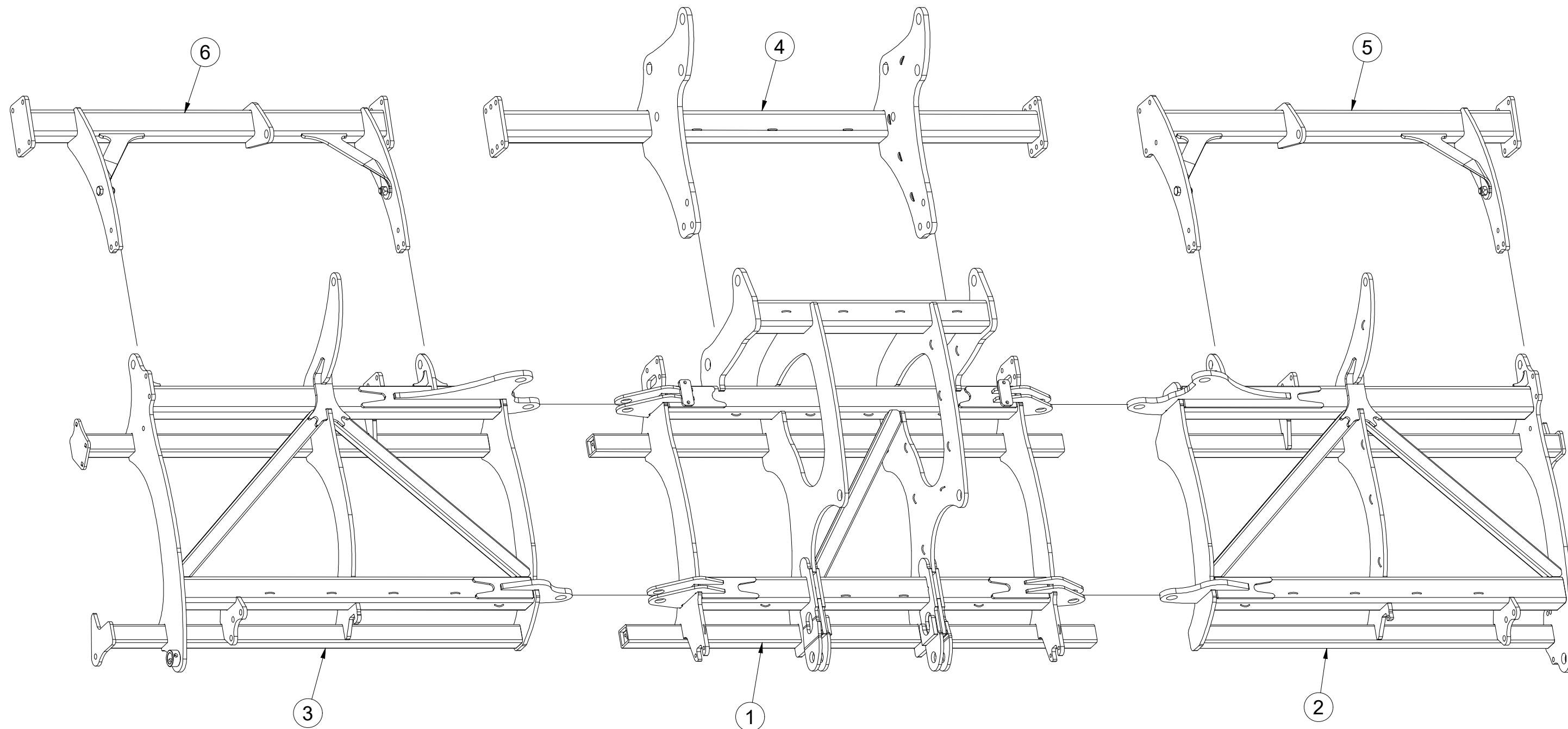

Pos.	Part Number	Pcs.
1	2000990	1
2	2001028	1
3	VZ00030812	1
4	3008698	1
5	3010495	1
6	3010496	1

Ⓒ ZÁKLAD STROJE

Ⓓ UNTERBAU DER MASCHINE

Ⓕ BÂTI DE LA MACHINE

Ⓖ FOOTING OF THE MACHINE

Ⓡ ОСНОВАНИЕ МАШИНЫ

Ⓟ PODSTAWA MASZYNY



VZ00036948

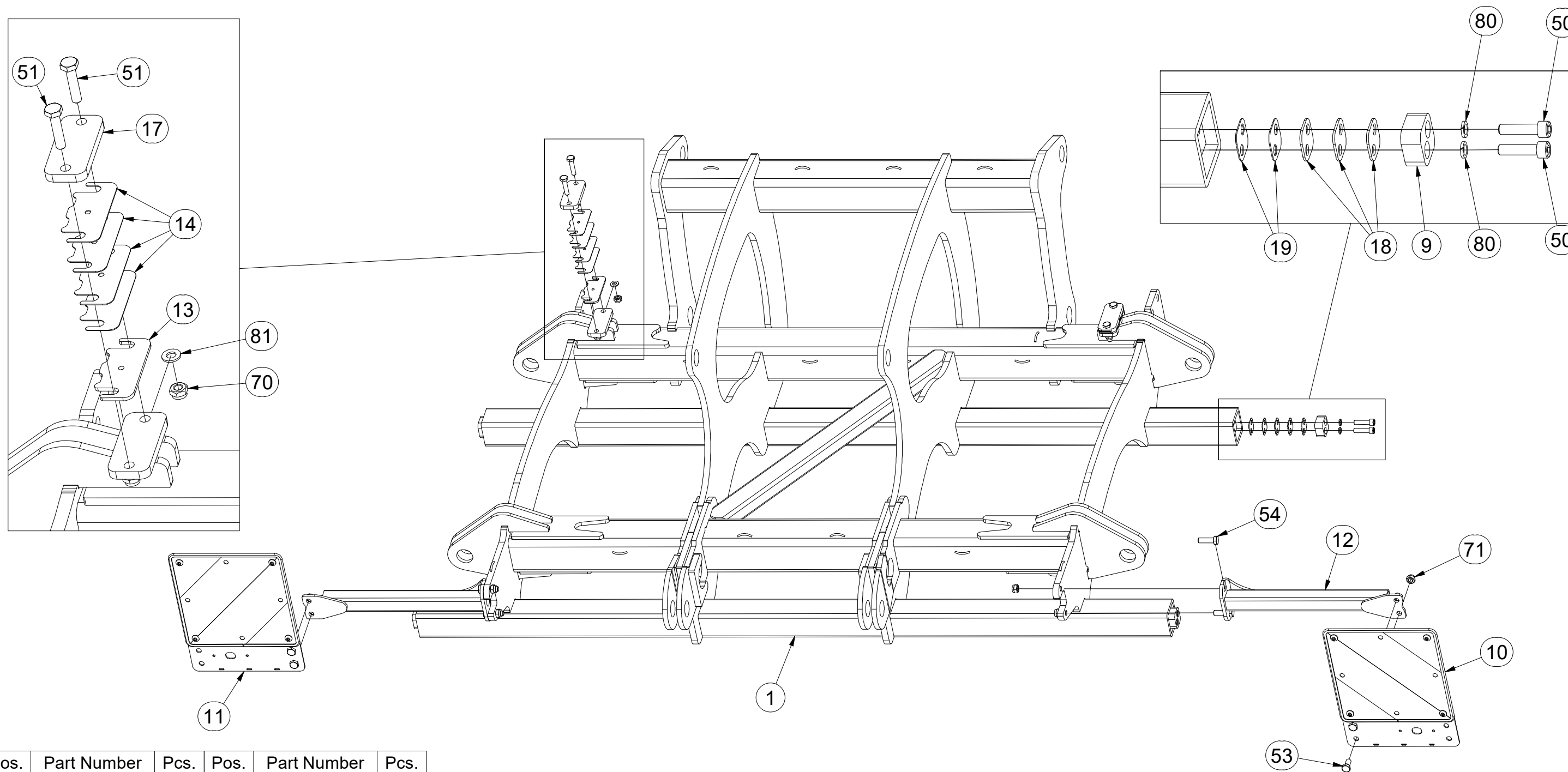

Pos.	Part Number	Pcs.	Pos.	Part Number	Pcs.
1	2000990	1	19	4017091	8
9	4017089	4	50	m14009	8
10	4025088	1	51	m10444	4
11	4025089	1	53	m08549	4
12	3012504	2	54	m03926	4
13	4010451	2	70	m03775	12
14	4009768	8	71	m04301	36
17	9003053	2	80	m01208	8
18	4017090	12	81	m01209	4

Ⓒ ZÁKLAD STROJE

Ⓓ UNTERBAU DER MASCHINE

Ⓕ BÂTI DE LA MACHINE

VZ00036948

Ⓖ FOOTING OF THE MACHINE

Ⓡ ОСНОВАНИЕ МАШИНЫ

Ⓟ PODSTAWA MASZyny

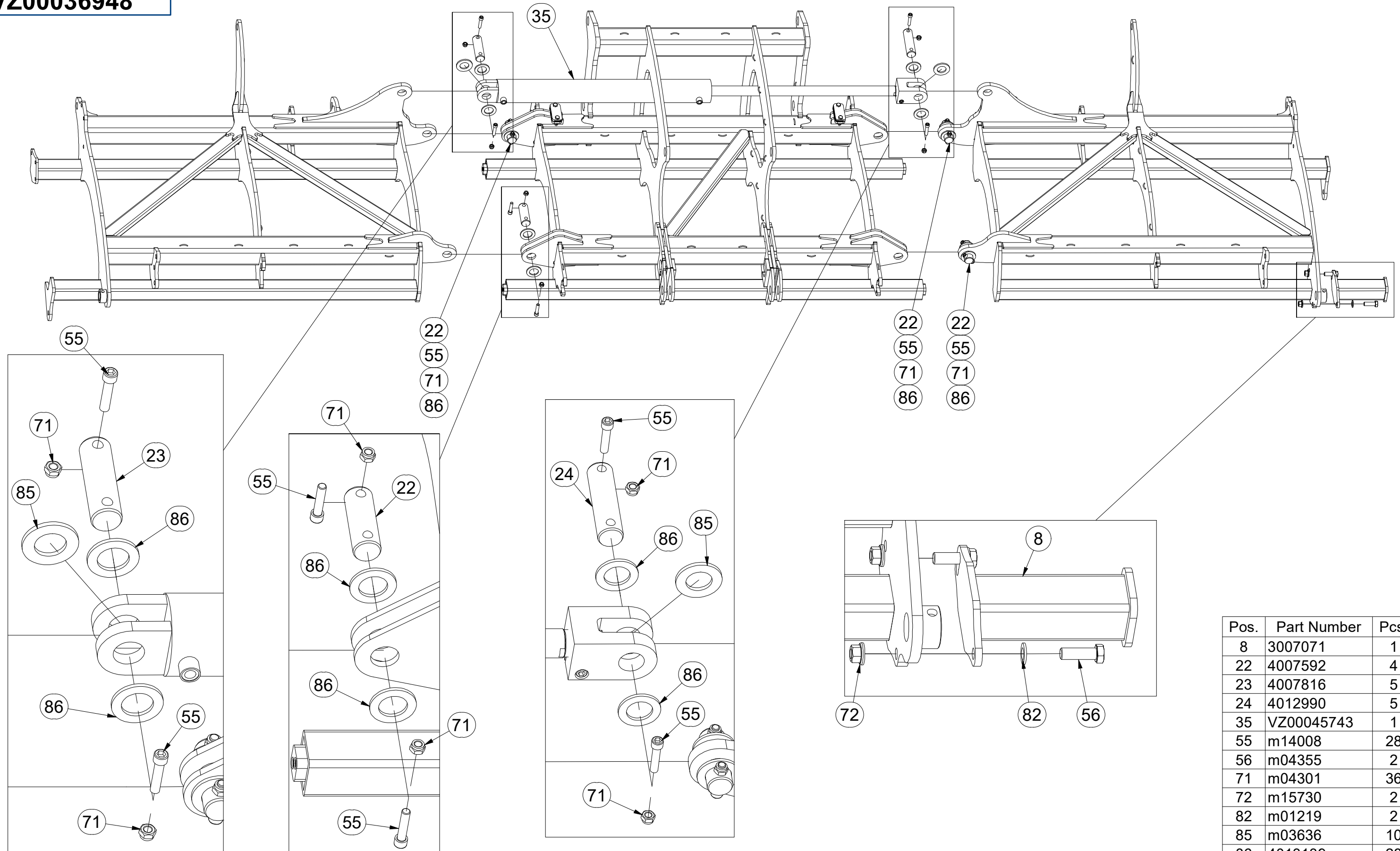

Pos.	Part Number	Pcs.
8	3007071	1
22	4007592	4
23	4007816	5
24	4012990	5
35	VZ00045743	1
55	m14008	28
56	m04355	2
71	m04301	36
72	m15730	2
82	m01219	2
85	m03636	10
86	4013139	28

☉ ZÁKLAD STROJE

Ⓧ UNTERBAU DER MASCHINE

Ⓧ BÂTI DE LA MACHINE

Ⓧ FOOTING OF THE MACHINE

Ⓧ ОСНОВАНИЕ МАШИНЫ

Ⓧ PODSTAWA MASZYNY



VZ00036948

Pos.	Part Number	Pcs.
5	3010495	1
15	4014704	8
20	4007584	2
21	4007639	2
31	VZ00045789	1
40	m14506	8
52	m14143	8
57	m14482	12
59	m08532	4
70	m03775	12
73	m03683	12
74	m07147	10
83	m02866	8
84	m14029	8

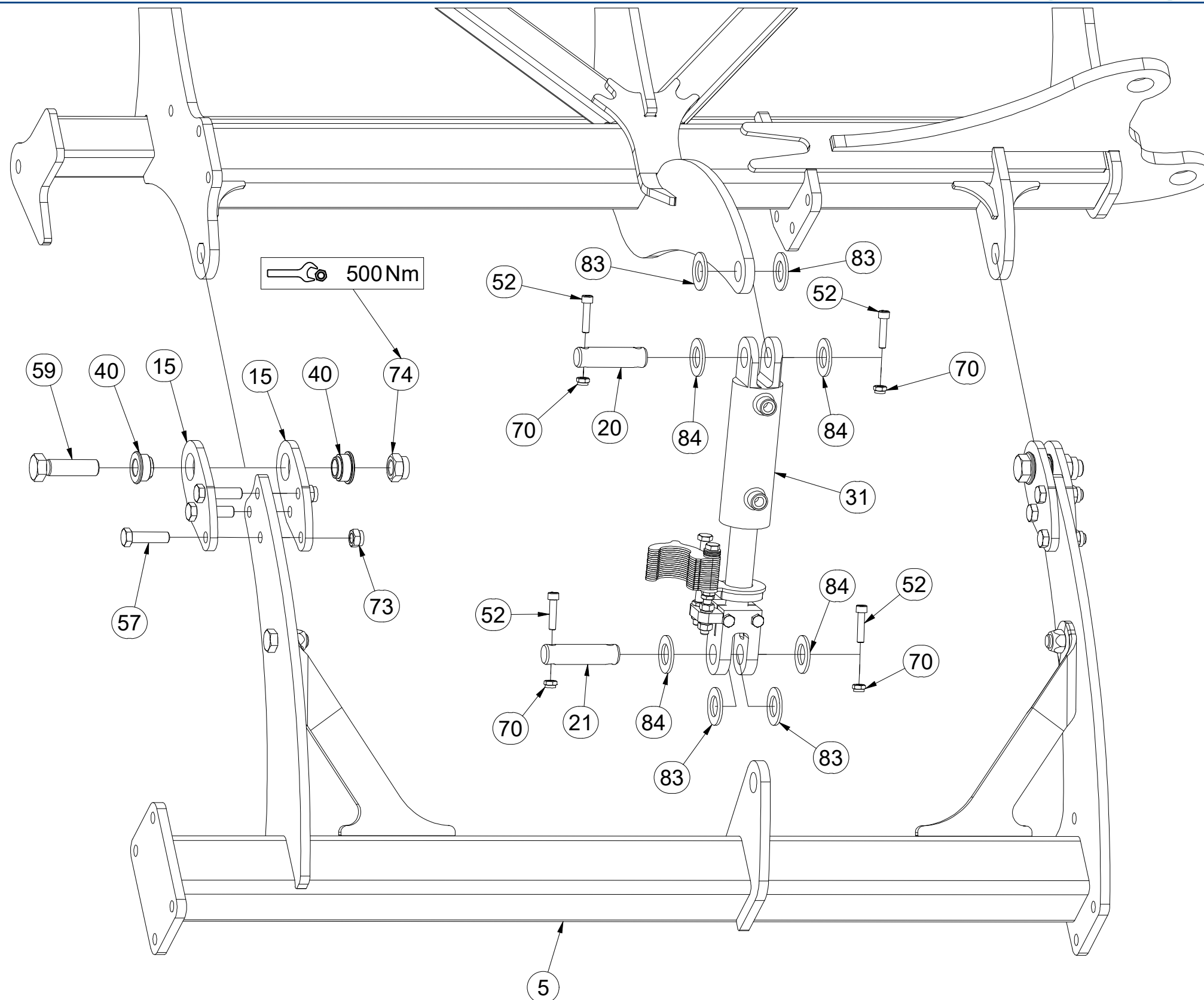
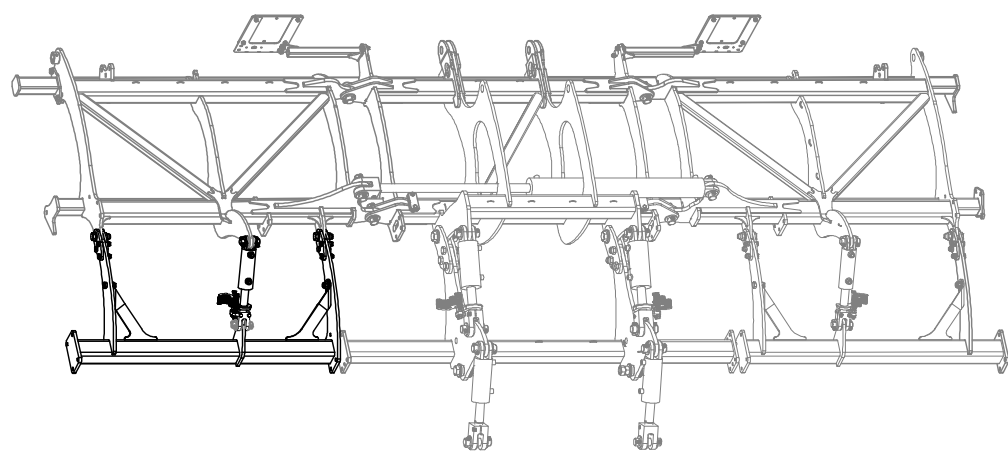

Ⓒ ZÁKLAD STROJE

Ⓓ UNTERBAU DER MASCHINE

Ⓕ BÂTI DE LA MACHINE

Ⓖ FOOTING OF THE MACHINE

Ⓡ ОСНОВАНИЕ МАШИНЫ

Ⓢ ПОДСТАВА МАСЗЫНЫ



VZ00036948

Pos.	Part Number	Pcs.
6	3010496	1
15	4014704	8
20	4007584	2
21	4007639	2
30	VZ00045796	1
40	m14506	8
52	m14143	8
57	m14482	12
59	m08532	4
70	m03775	12
73	m03683	12
74	m07147	10
83	m02866	8
84	m14029	8

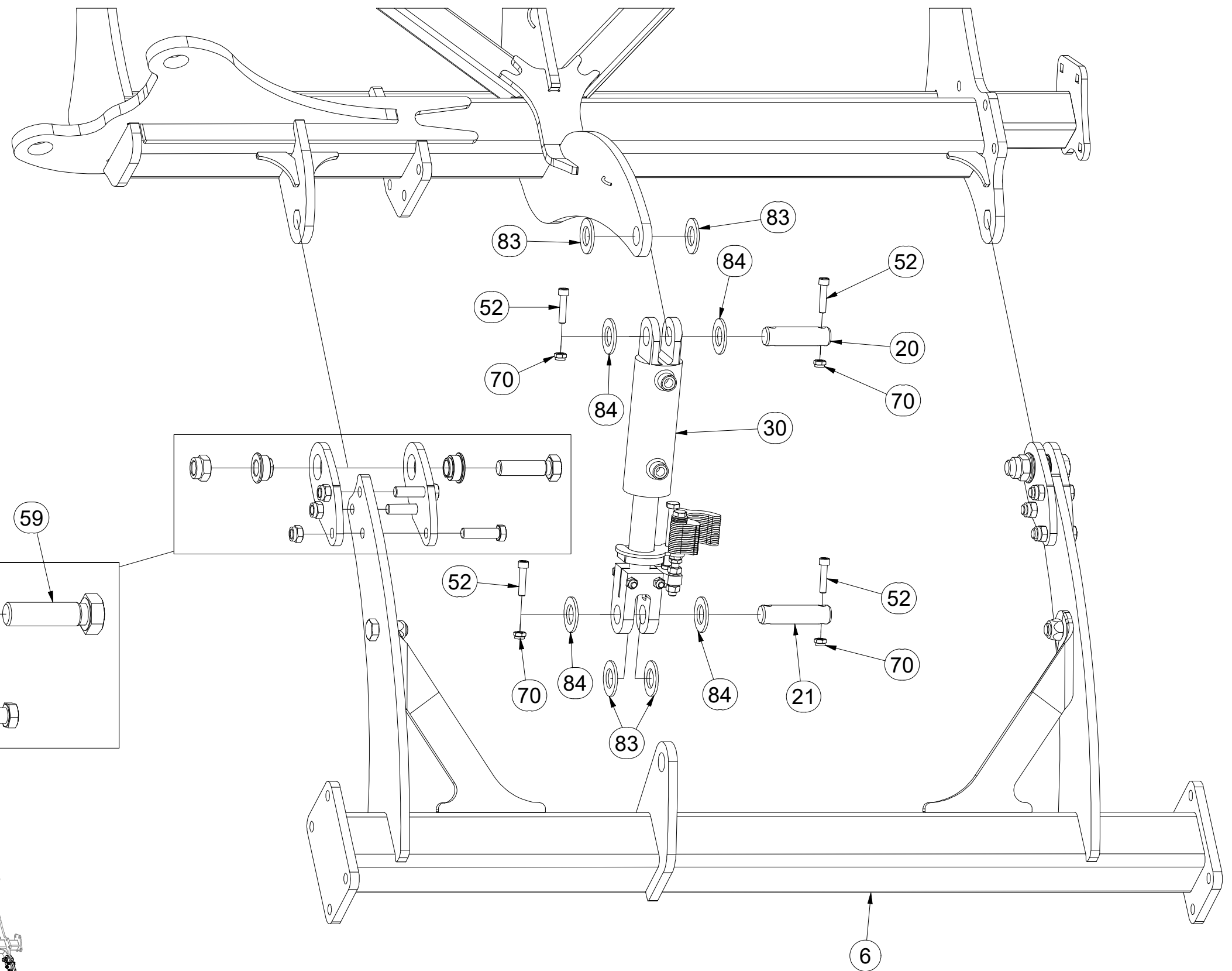

500Nm

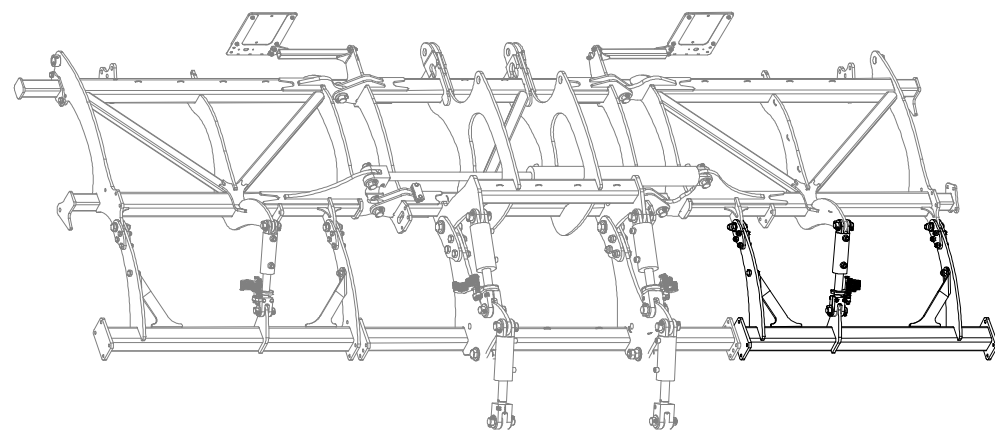
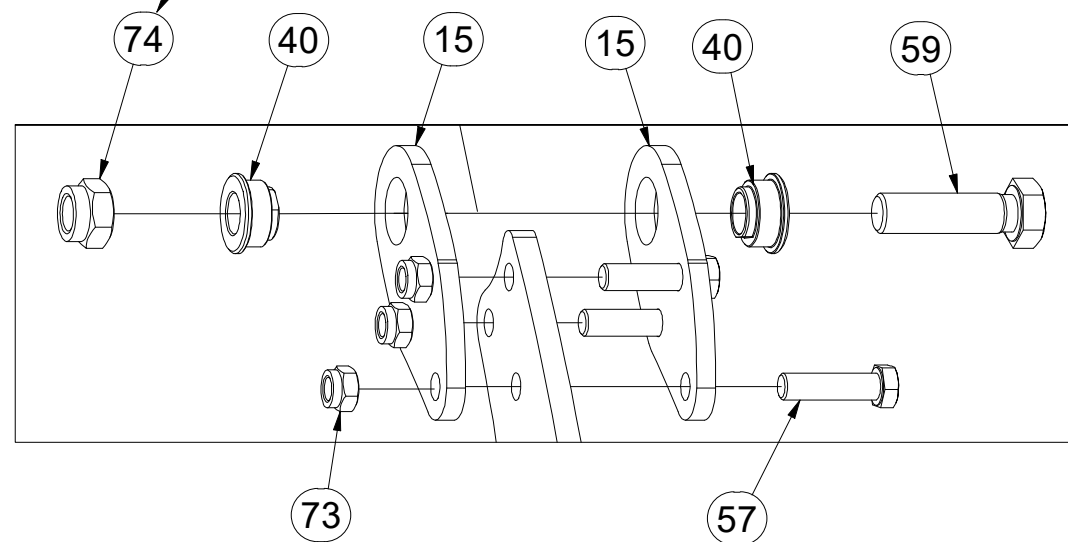

☉ ZÁKLAD STROJE

Ⓧ UNTERBAU DER MASCHINE

Ⓧ BÂTI DE LA MACHINE

Ⓧ FOOTING OF THE MACHINE

Ⓧ ОСНОВАНИЕ МАШИНЫ

Ⓧ PODSTAWA MASZyny



VZ00036948

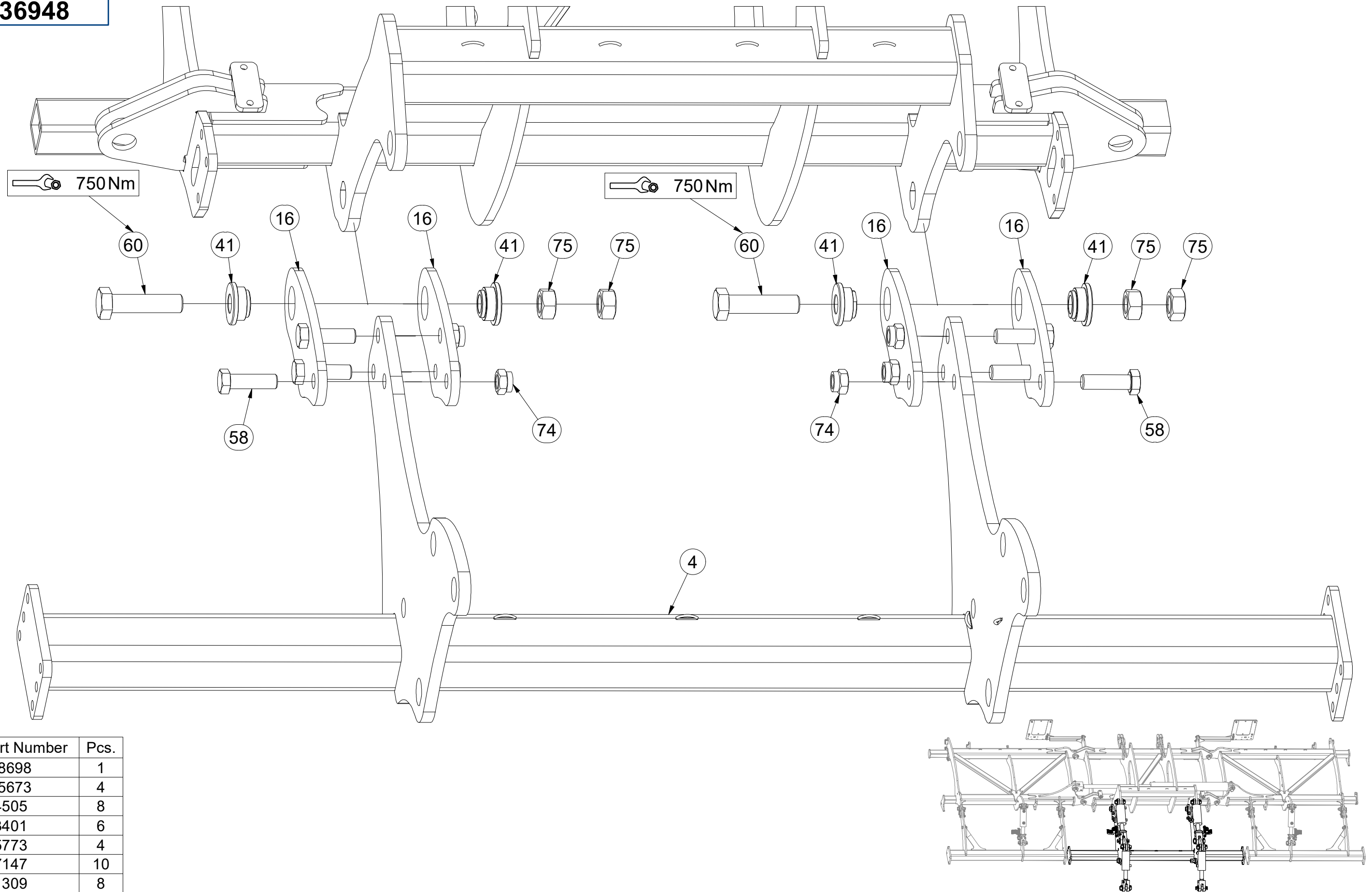

Pos.	Part Number	Pcs.
4	3008698	1
16	4015673	4
41	m14505	8
58	m03401	6
60	m15773	4
74	m07147	10
75	m01309	8

☉ ZÁKLAD STROJE

☉ UNTERBAU DER MASCHINE

☉ BÂTI DE LA MACHINE

☉ FOOTING OF THE MACHINE

☉ ОСНОВАНИЕ МАШИНЫ

☉ PODSTAWA MASZYNY



VZ00036948

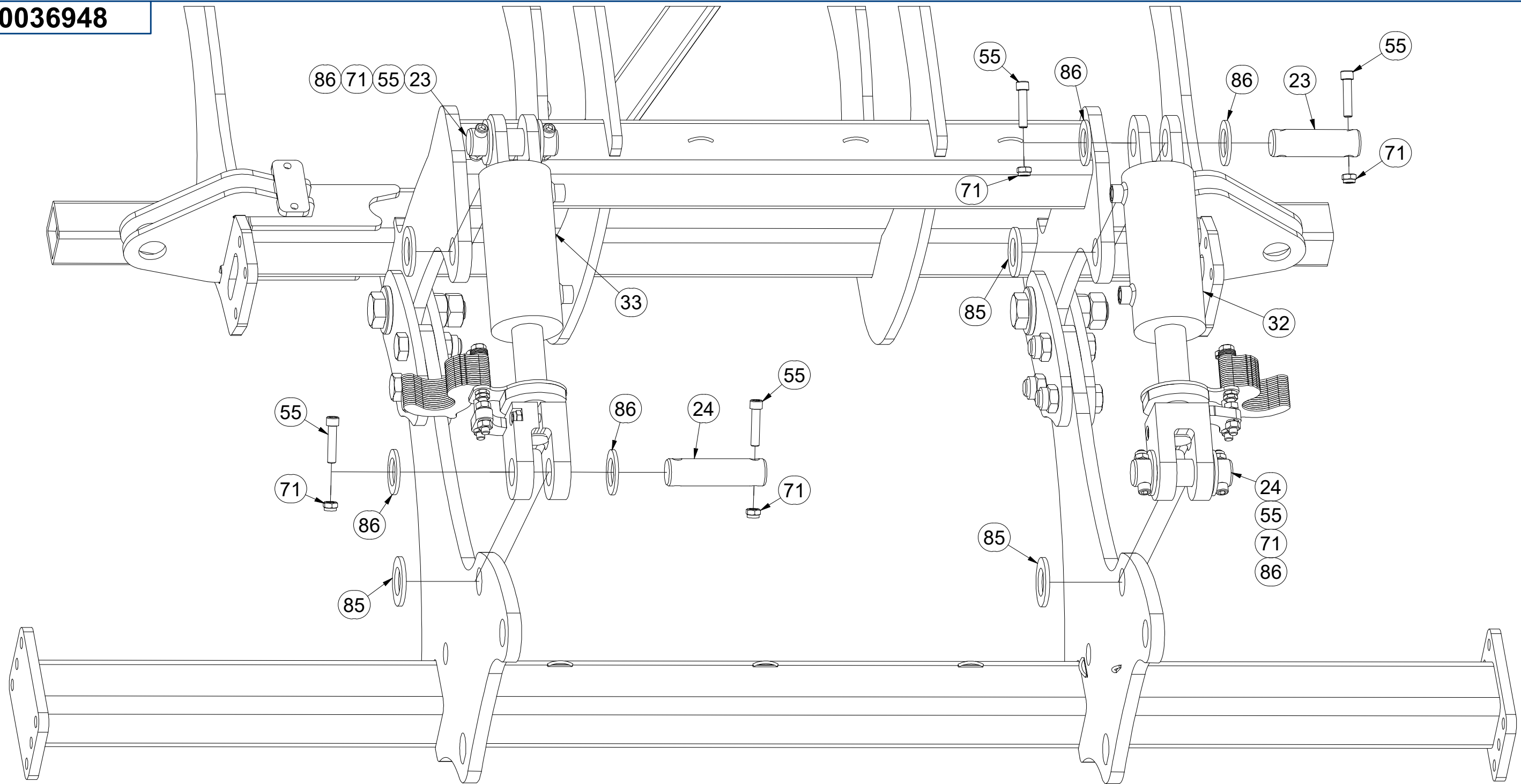

Pos.	Part Number	Pcs.
23	4007816	5
24	4012990	5
32	VZ00046358	1
33	VZ00046276	1
55	m14008	28
71	m04301	36
85	m03636	10
86	4013139	28

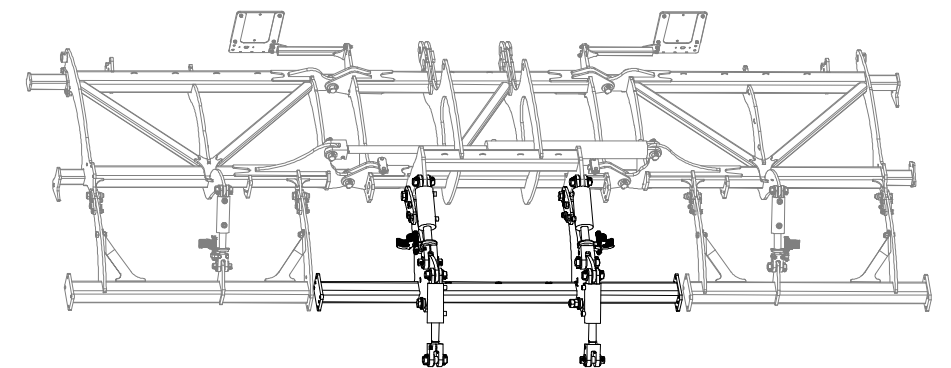

Ⓒ ZÁKLAD STROJE

Ⓓ UNTERBAU DER MASCHINE

Ⓕ BÂTI DE LA MACHINE

Ⓖ FOOTING OF THE MACHINE

Ⓡ ОСНОВАНИЕ МАШИНЫ

Ⓟ PODSTAWA MASZyny



VZ00036948

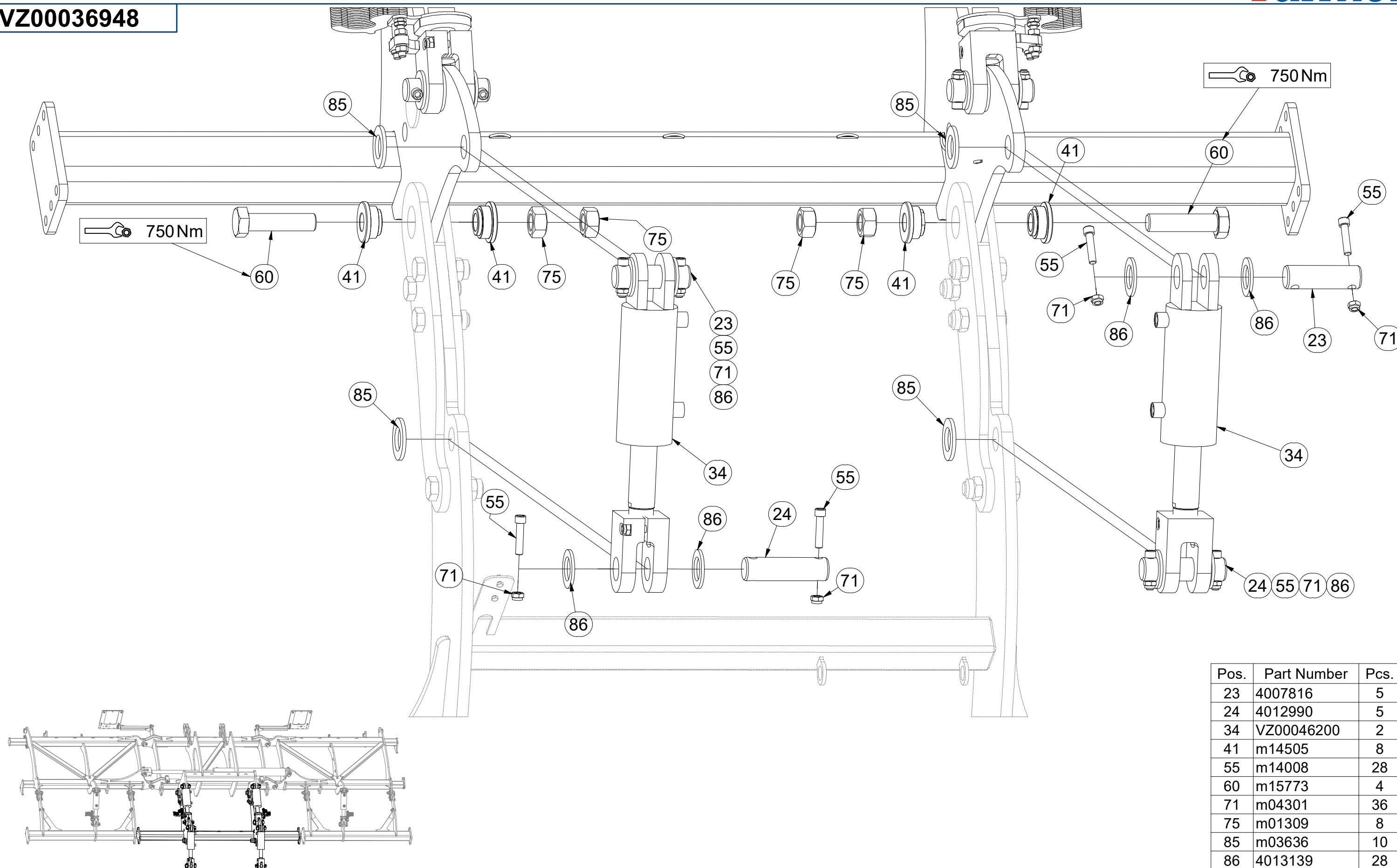

Pos.	Part Number	Pcs.
23	4007816	5
24	4012990	5
34	VZ00046200	2
41	m14505	8
55	m14008	28
60	m15773	4
71	m04301	36
75	m01309	8
85	m03636	10
86	4013139	28

Ⓒ SPOJOVACÍ TÁHLO
Ⓓ VERBINDUNGSSTANGE
Ⓕ TIGE DE RACCORDEMENT

Ⓒ CONNECTING ROD
Ⓓ СОЕДИНИТЕЛЬНАЯ ТЯГА
Ⓕ KORBOWÓD



4023816

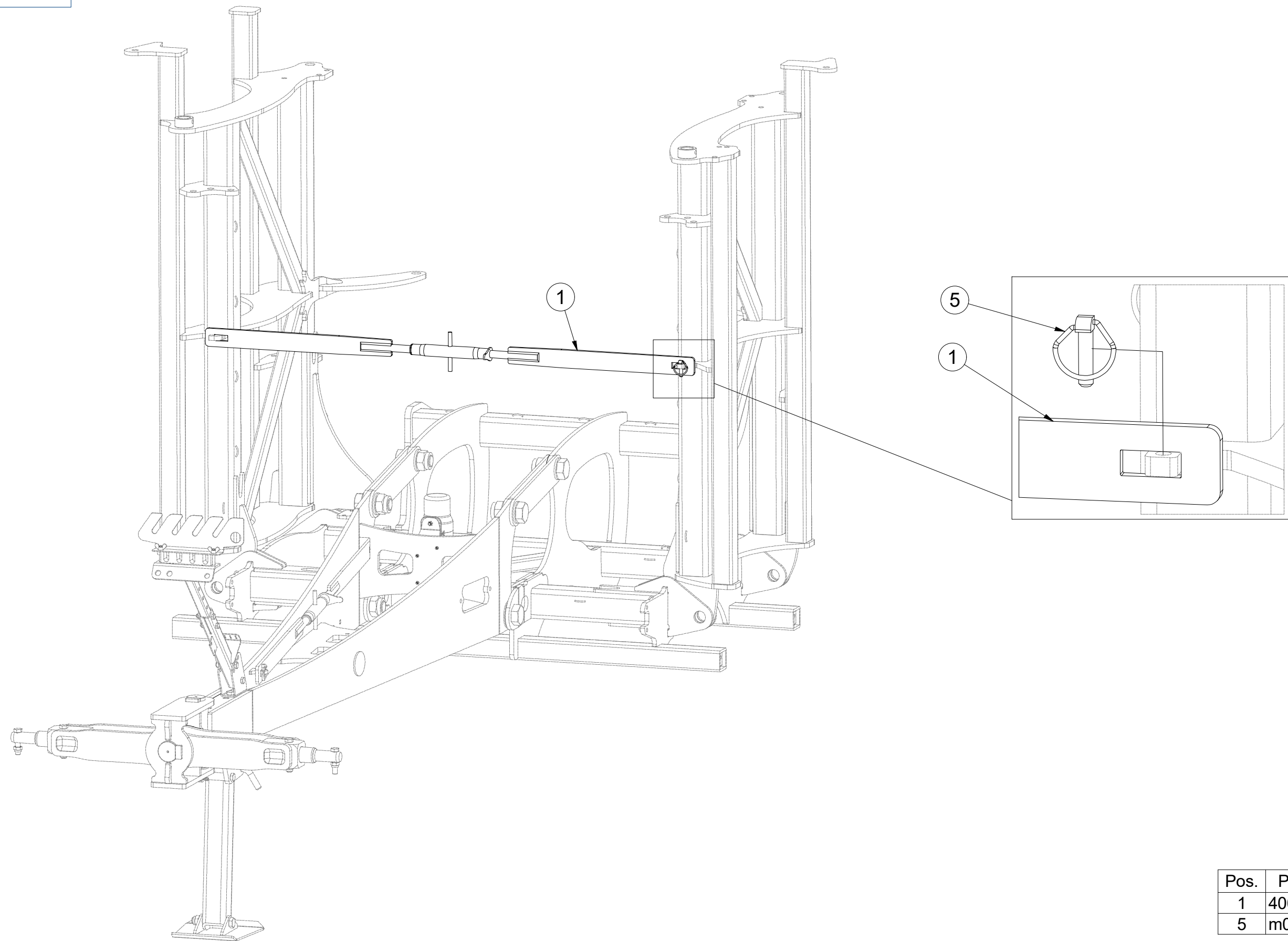

Pos.	Part Number	Pcs.
1	4009414	1
5	m02505	1

(CZ) SPOJOVACÍ TÁHLŮ
 (D) VERBINDUNGSSTANGE
 (F) TIGE DE RACCORDEMENT

(GB) CONNECTING ROD
 (RU) СОЕДИНИТЕЛЬНАЯ ТЯГА
 (PL) KORBOWÓD



4009414

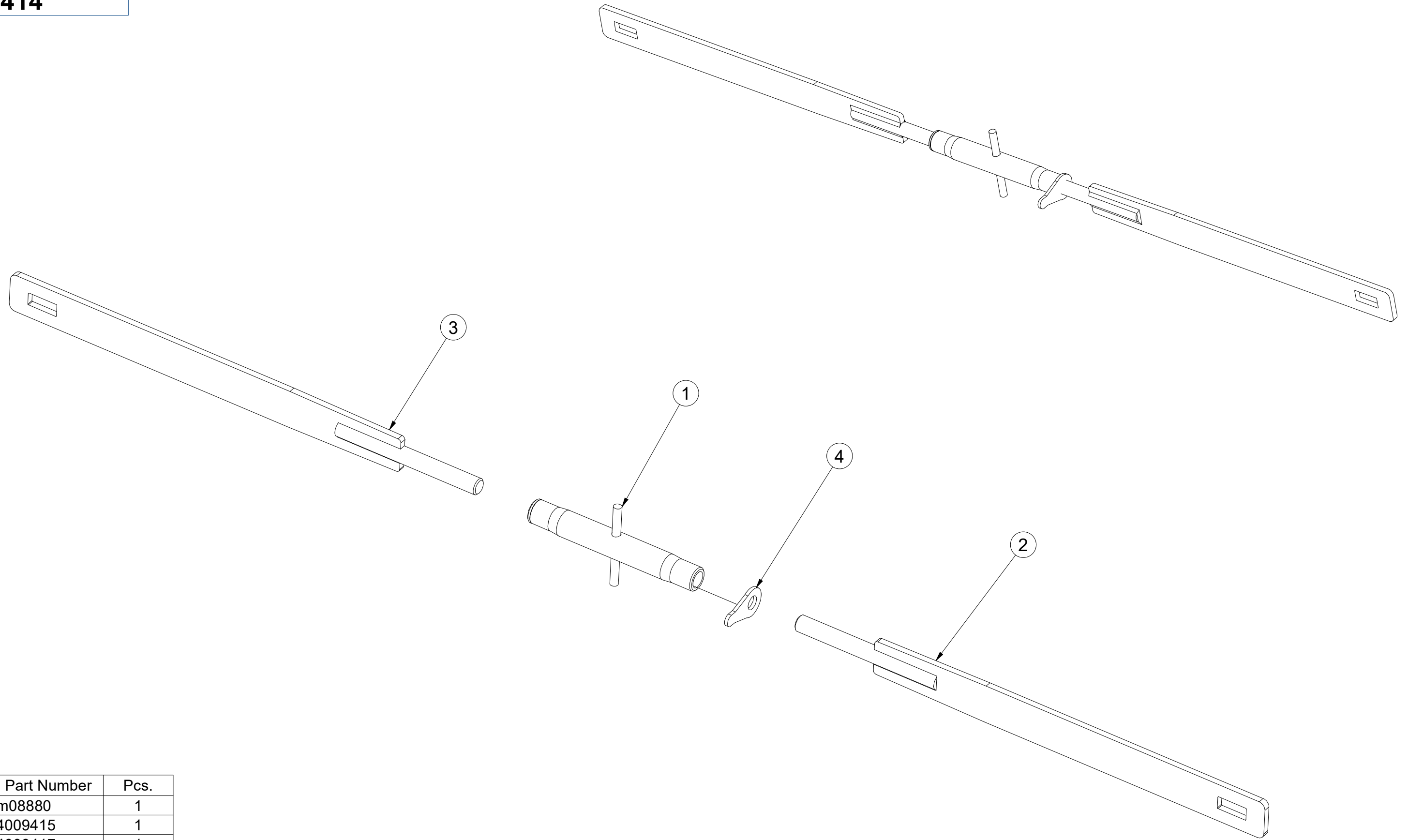

Pos.	Part Number	Pcs.
1	m08880	1
2	4009415	1
3	4009417	1
4	m08881	1

CZ TERČ PŘEDNÍ
 D SCHILD, VORDERES
 F CIBLE AVANT

GB FRONT DISC
 RU ЩИТОК ПЕРЕДНИЙ
 PL TARCZA PRZEDNIA



4025088

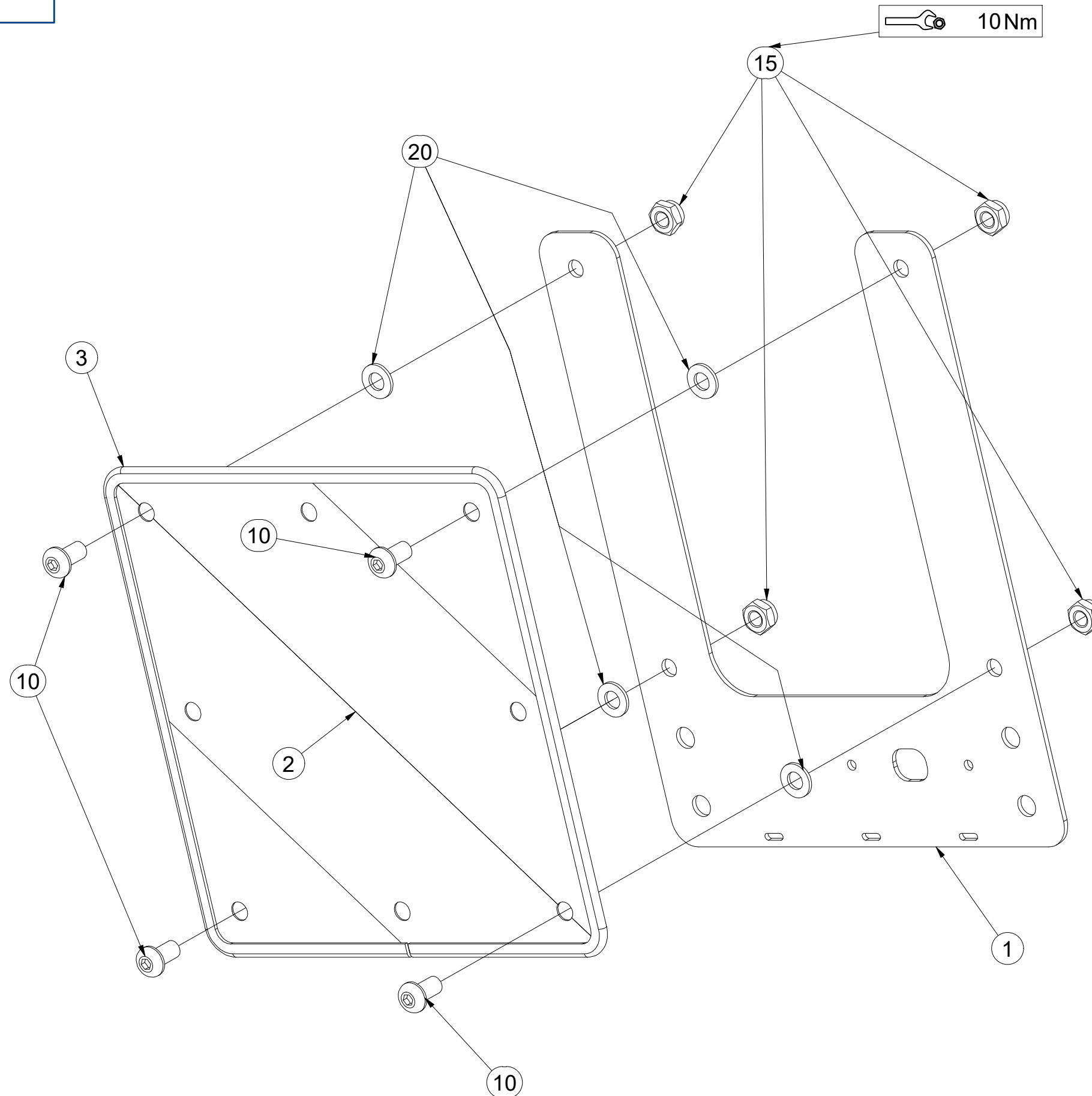

Pos.	Part Number	Pcs.
1	4025090	1
2	m18855	1
3	9005707	1
10	m16637	4
15	m03775	4
20	m01209	4

CZ TERČ PŘEDNÍ
 D SCHILD, VORDERES
 F CIBLE AVANT

GB FRONT DISC
 RU ЩИТОК ПЕРЕДНИЙ
 PL TARCZA PRZEDNIA



4025089

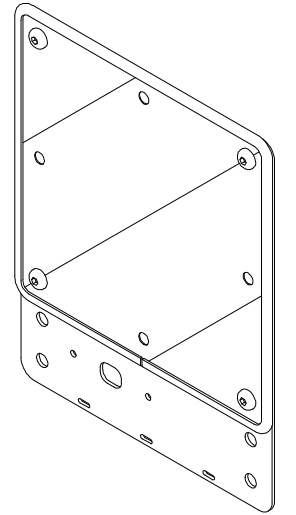
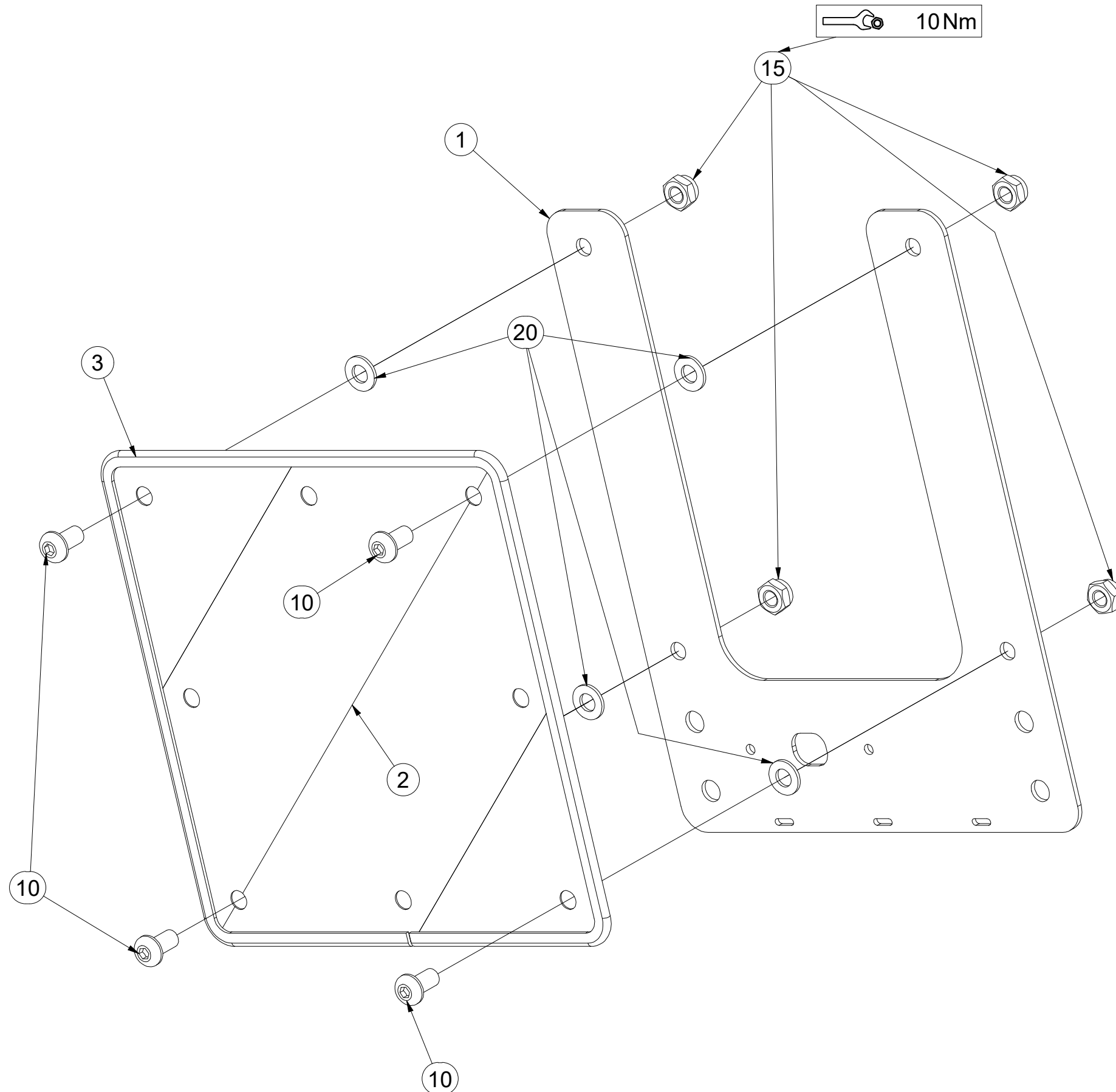

Pos.	Part Number	Pcs.
1	4025090	1
2	m18855	1
3	9005707	1
10	m16637	4
15	m03775	4
20	m01209	4

CZ SADA DISKŮ
 D SCHEIBENSATZ
 F KIT DE DISQUES

GB DISC SET
 RU КОМПЛЕКТ ДИСКОВ
 PL ZESTAW TALERZY



VZ00022496

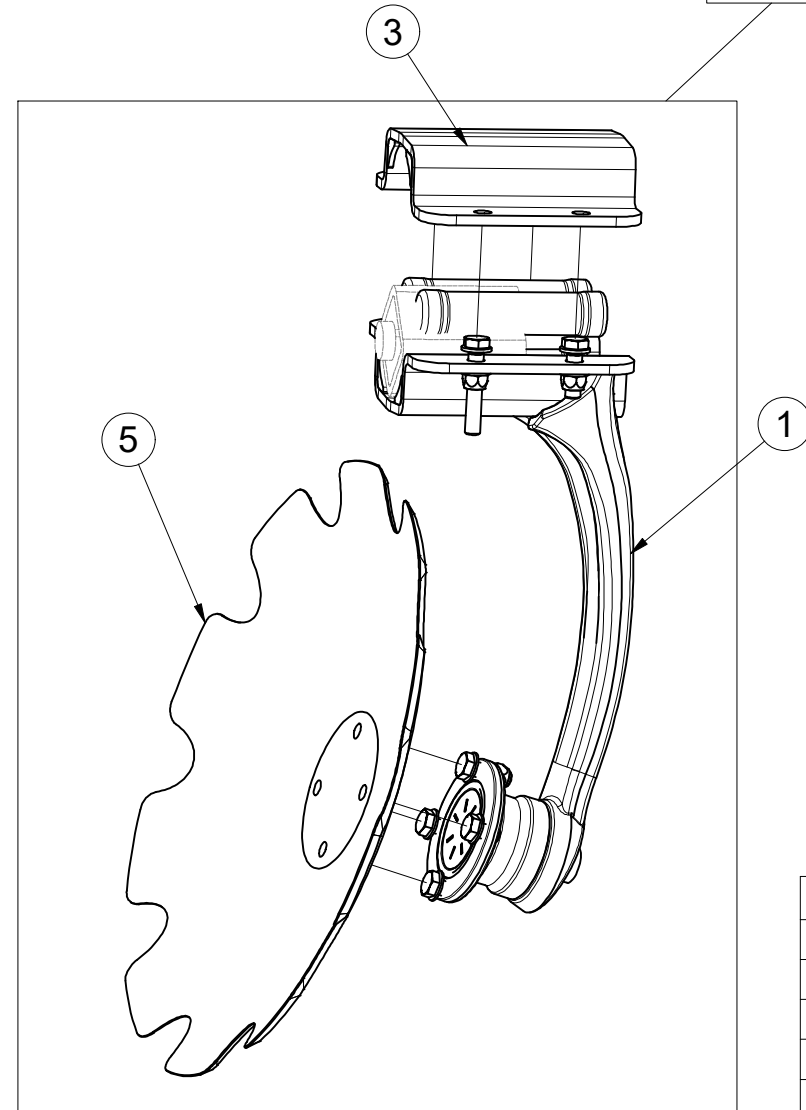
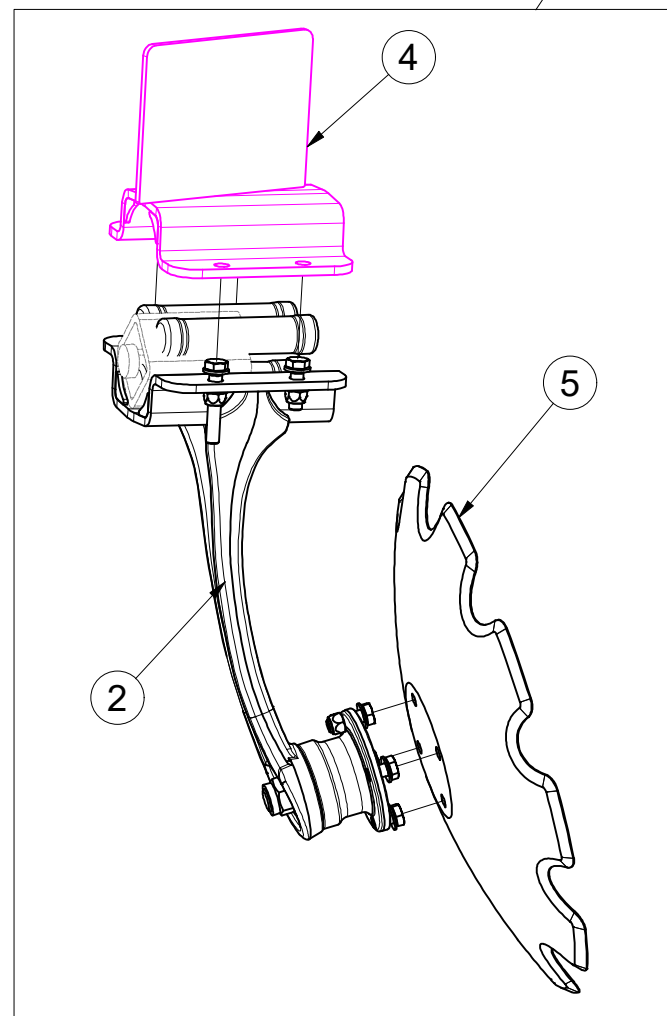
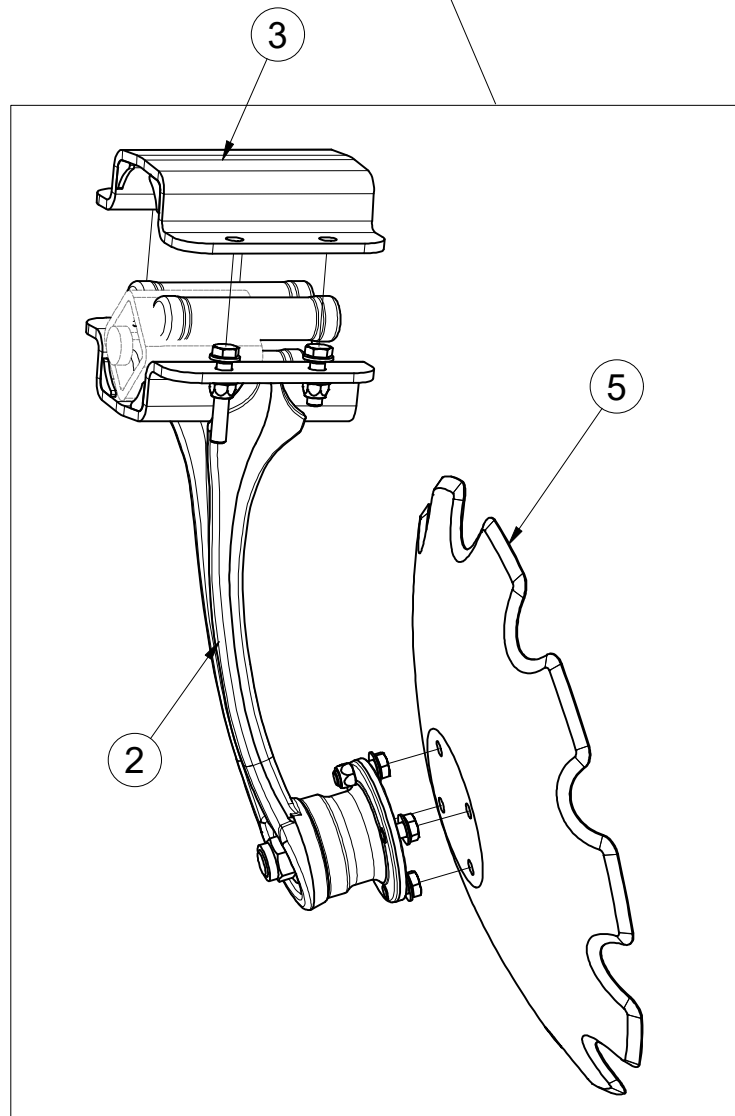
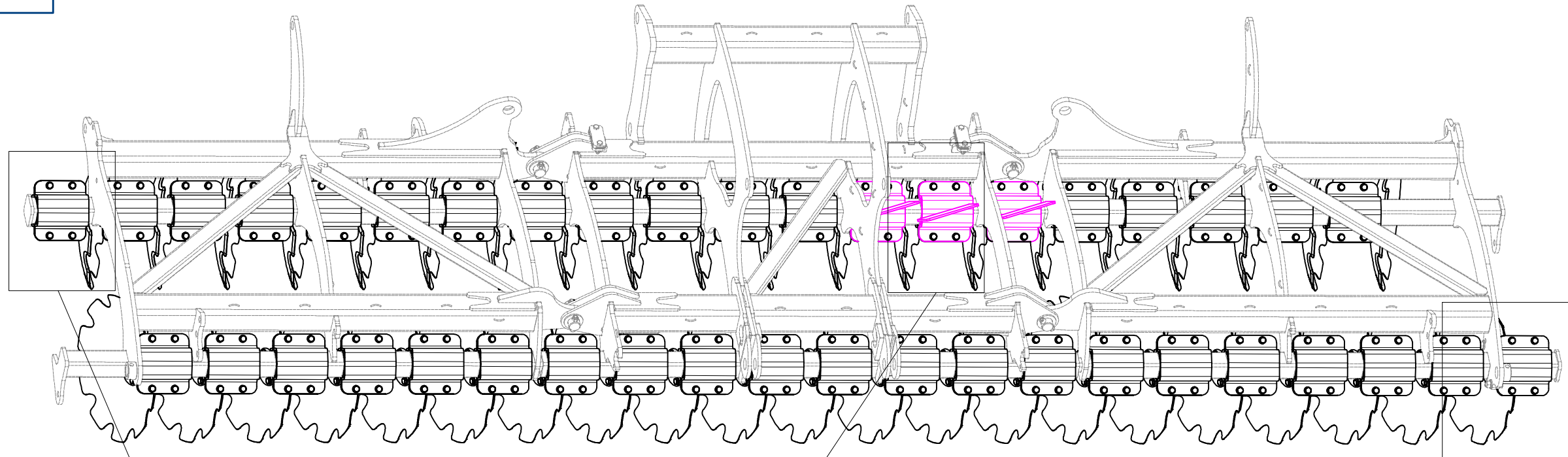

Pos.	Part Number	Pcs.
1	3008374	21
2	3008375	20
3	9004269	38
4	4016392	3
5	3007653	41

CZ PŘEDNÍ DISK
 D SCHEIBE, VORDERE
 F DISQUE AVANT

GB FRONT DISC
 RU ДИСК ПЕРЕДНИЙ
 PL TALERZ PRZEDNI



3008374

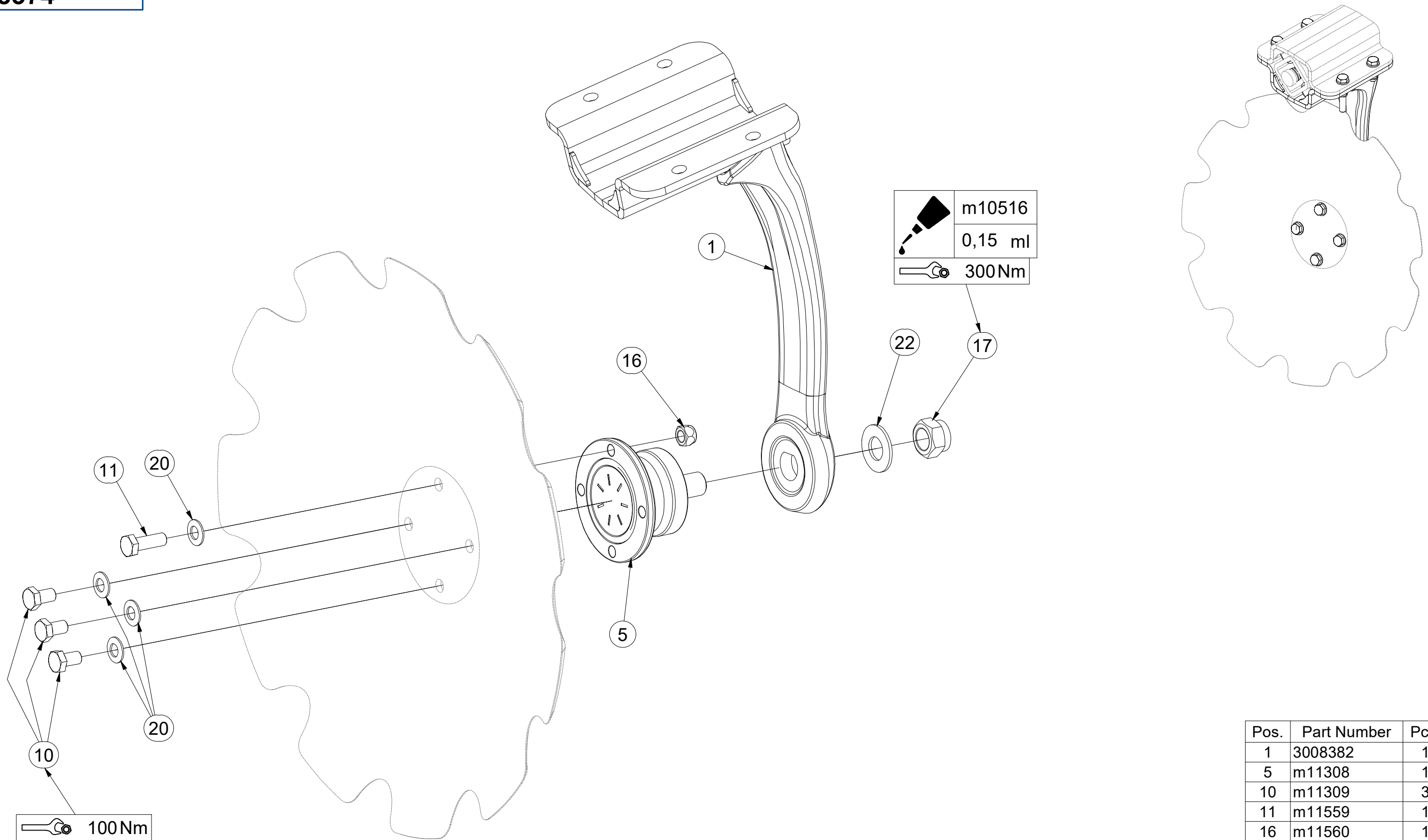

Pos.	Part Number	Pcs.
1	3008382	1
5	m11308	1
10	m11309	3
11	m11559	1
16	m11560	1
17	m11313	1
20	m17545	4
22	VZ00011395	1

CZ PŘEDNÍ DISK
 D SCHEIBE, VORDERE
 F DISQUE AVANT

GB FRONT DISC
 RU ДИСК ПЕРЕДНИЙ
 PL TALERZ PRZEDNI



3008374

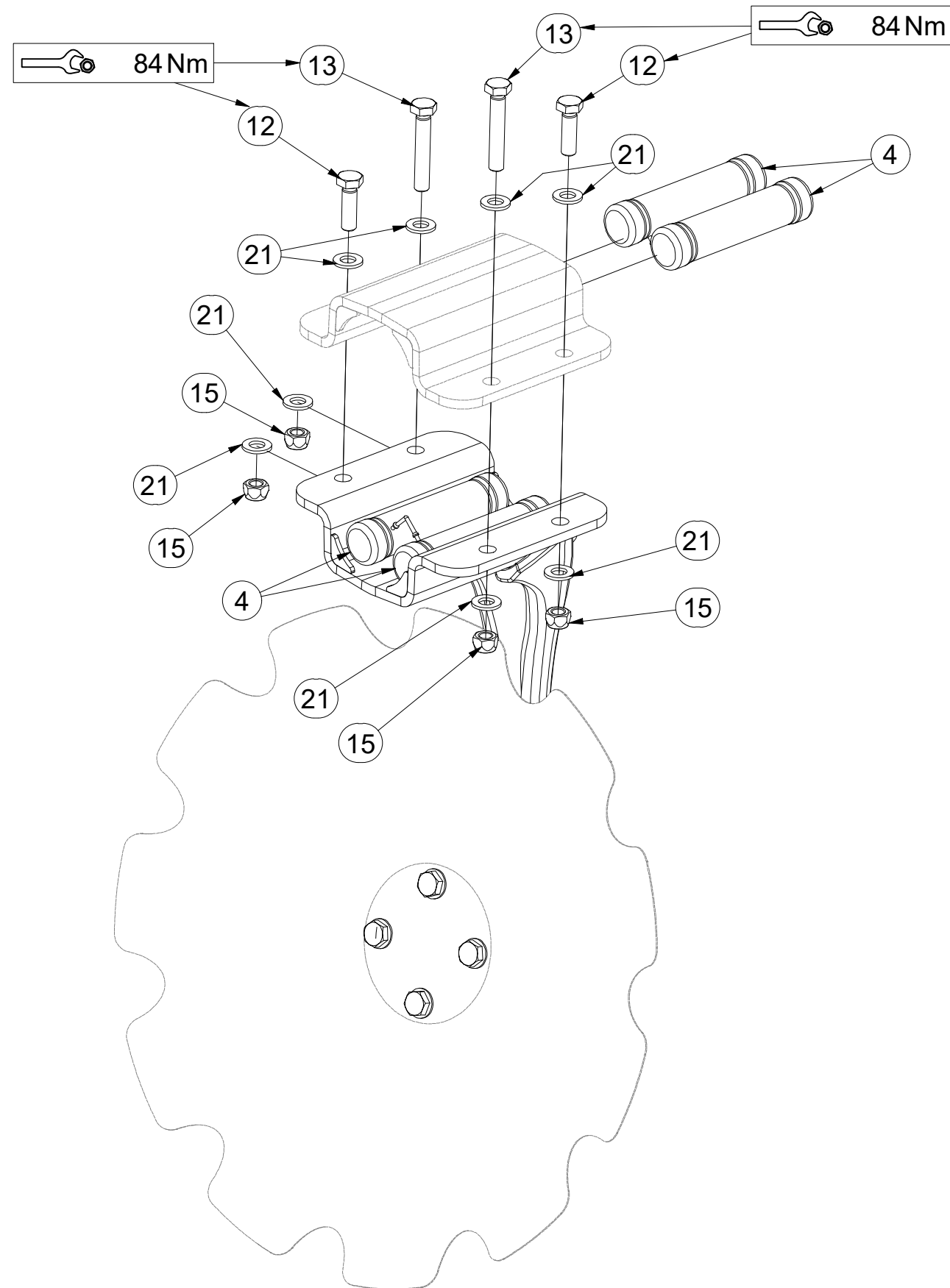

Pos.	Part Number	Pcs.
4	VZ00003901	4
12	m17657	2
13	m17653	2
15	m12134	4
21	m17741	8

CZ ZADNÍ DISK
 D SCHEIBE, HINTERE
 F DISQUE ARRIÈRE

GB REAR DISC
 RU ДИСК ЗАДНИЙ
 PL TALERZ TYLNY



3008375

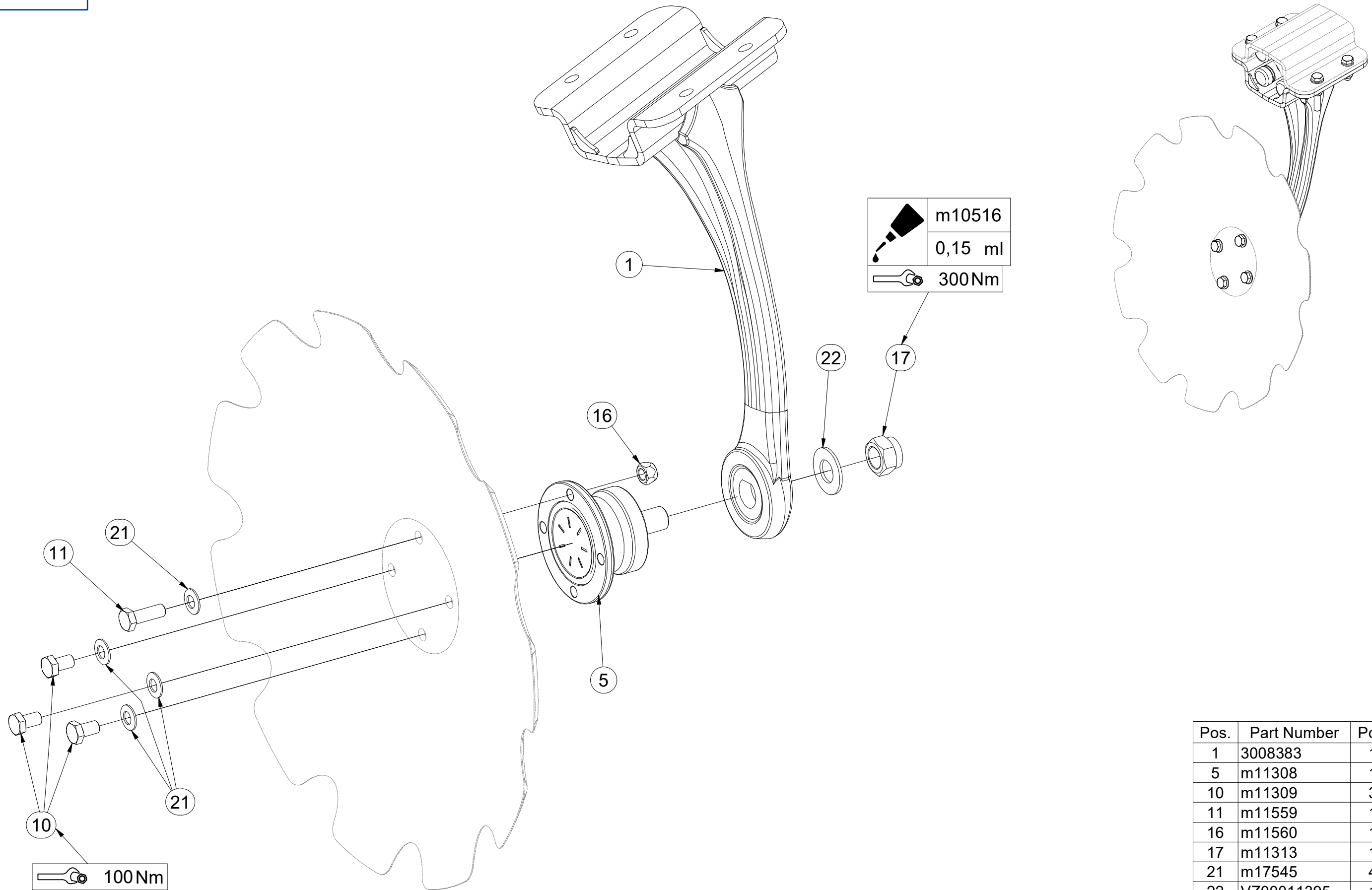

Pos.	Part Number	Pcs.
1	3008383	1
5	m11308	1
10	m11309	3
11	m11559	1
16	m11560	1
17	m11313	1
21	m17545	4
22	VZ00011395	1

CZ ZADNÍ DISK
 D SCHEIBE, HINTERE
 F DISQUE ARRIÈRE

GB REAR DISC
 RU ДИСК ЗАДНИЙ
 PL TALERZ TYLNY



3008375

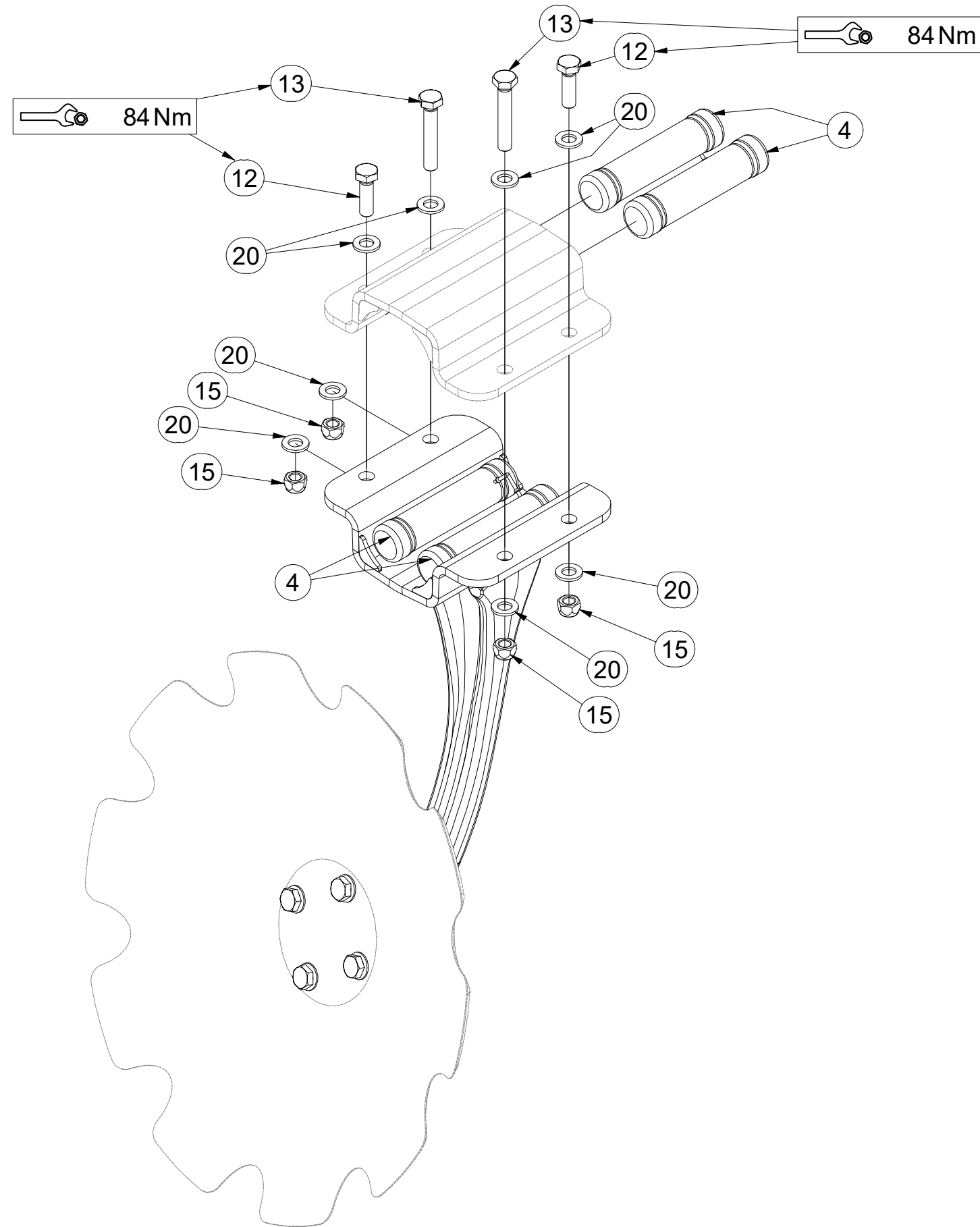

Pos.	Part Number	Pcs.
4	VZ00003901	4
12	m17657	2
13	m17653	2
15	m12134	4
20	m17741	8

CZ DEFLEKTOR LEVÝ
 D DEFLEKTOR, LINKER
 F DÉFLECTEUR GAUCHE

GB DEFLECTOR LEFT
 RU ДЕФЛЕКТОР ЛЕВЫЙ
 PL DEFLEKTOR LEWY

Farmet

3009574

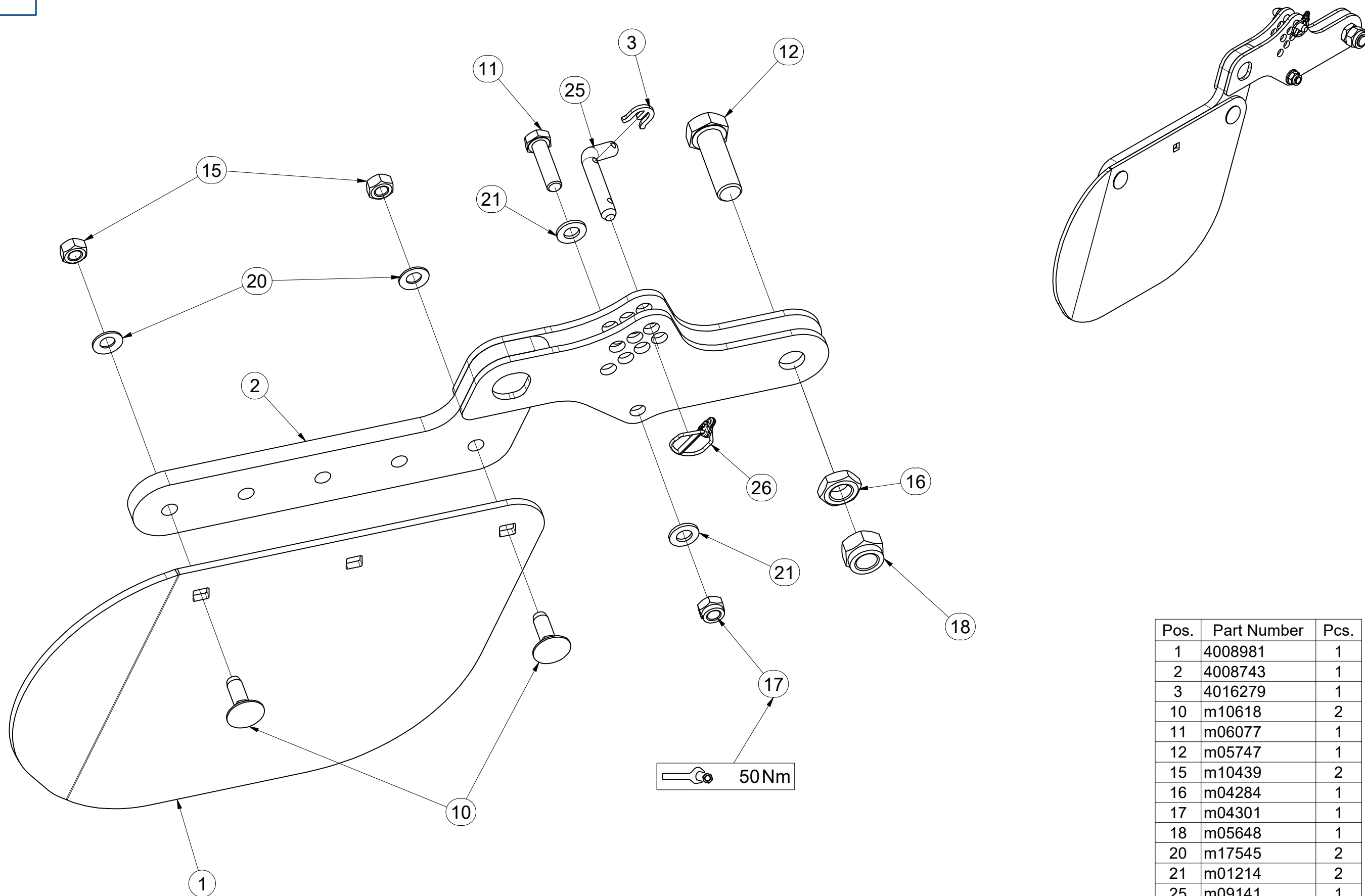

Pos.	Part Number	Pcs.
1	4008981	1
2	4008743	1
3	4016279	1
10	m10618	2
11	m06077	1
12	m05747	1
15	m10439	2
16	m04284	1
17	m04301	1
18	m05648	1
20	m17545	2
21	m01214	2
25	m09141	1
26	m10454	1

Ⓒ DEFLEKTOR PRAVÝ
Ⓓ DEFLEKTOR, RECHTER
Ⓕ DÉFLECTEUR DROIT

VZ00036778

Ⓖ DEFLECTOR RIGHT
Ⓔ ДЕФЛЕКТОР ПРАВЫЙ
Ⓗ DEFLEKTOR PRAWY

Farmet

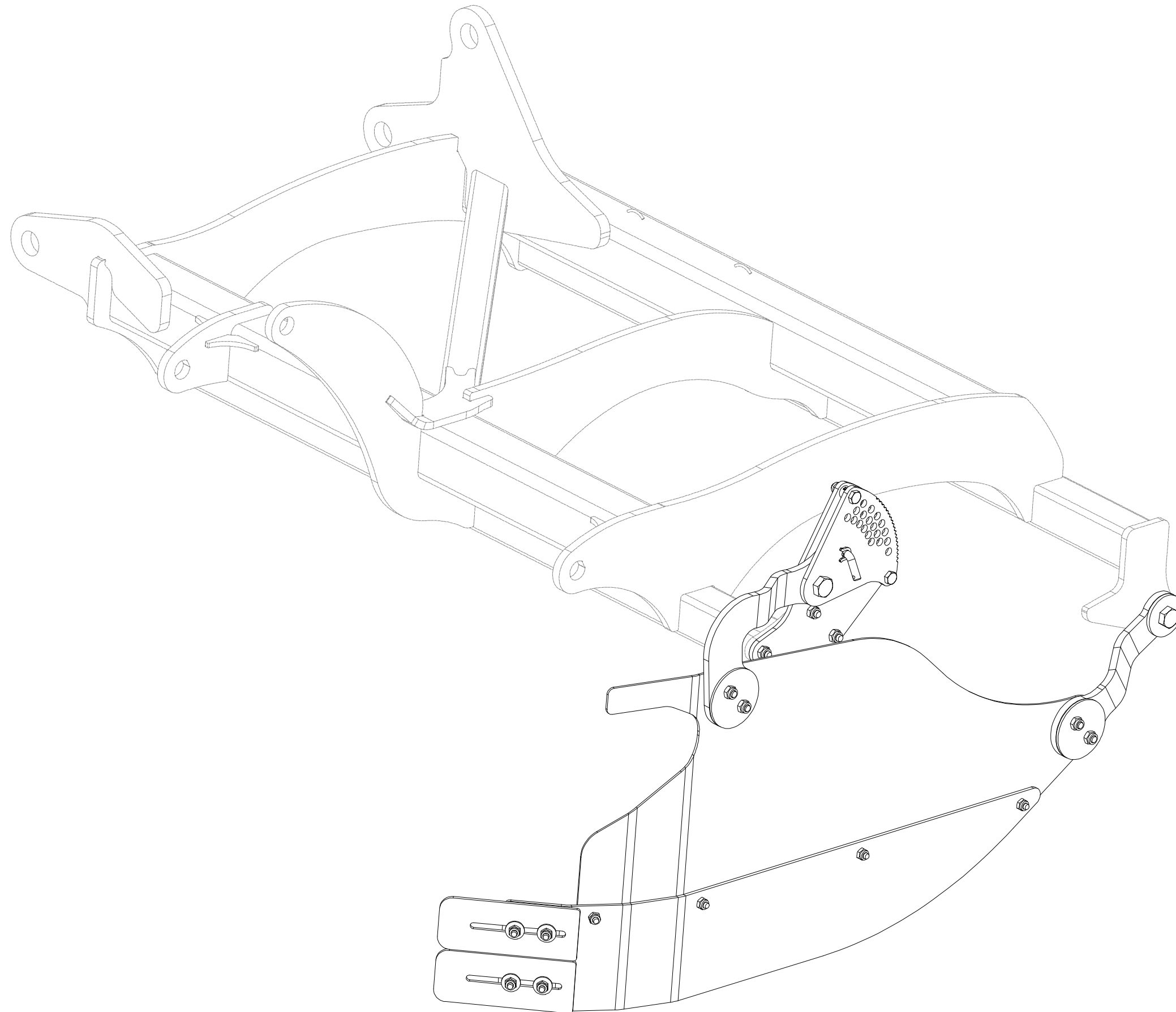

CZ DEFLEKTOR PRAVÝ
 D DEFLEKTOR, RECHTER
 F DÉFLECTEUR DROIT

GB DEFLECTOR RIGHT
 RU ДЕФЛЕКТОР ПРАВЫЙ
 PL DEFLEKTOR PRAWY



VZ00036778

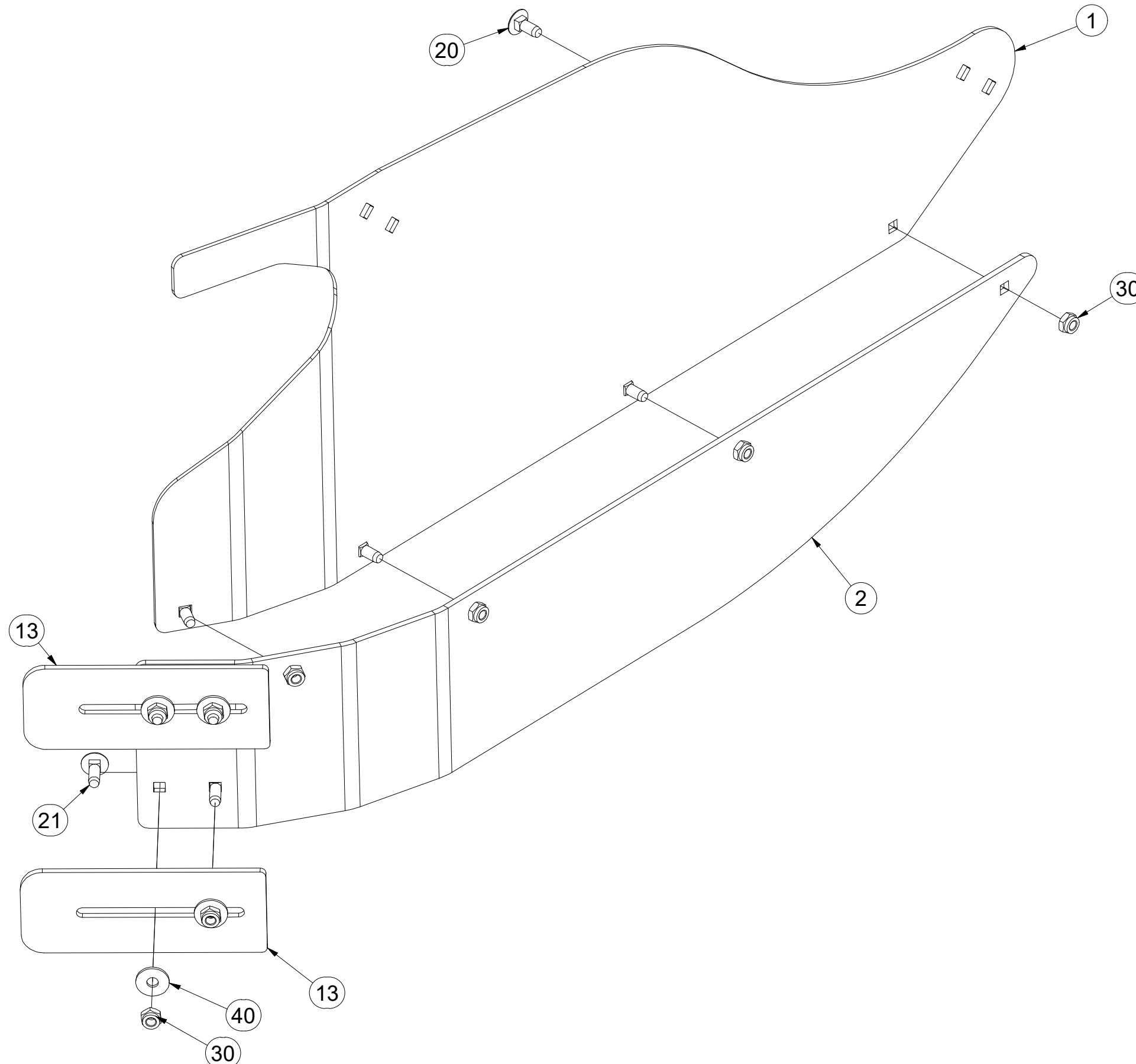

Pos.	Part Number	Pcs.
1	VZ00023005	1
2	VZ00022377	1
13	VZ00022131	2
20	m03129	4
21	m19153	4
30	m03775	8
40	m16981	4

CZ DEFLEKTOR PRAVÝ
 D DEFLEKTOR, RECHTER
 F DÉFLECTEUR DROIT

GB DEFLECTOR RIGHT
 RU ДЕФЛЕКТОР ПРАВЫЙ
 PL DEFLEKTOR PRAWY



VZ00036778

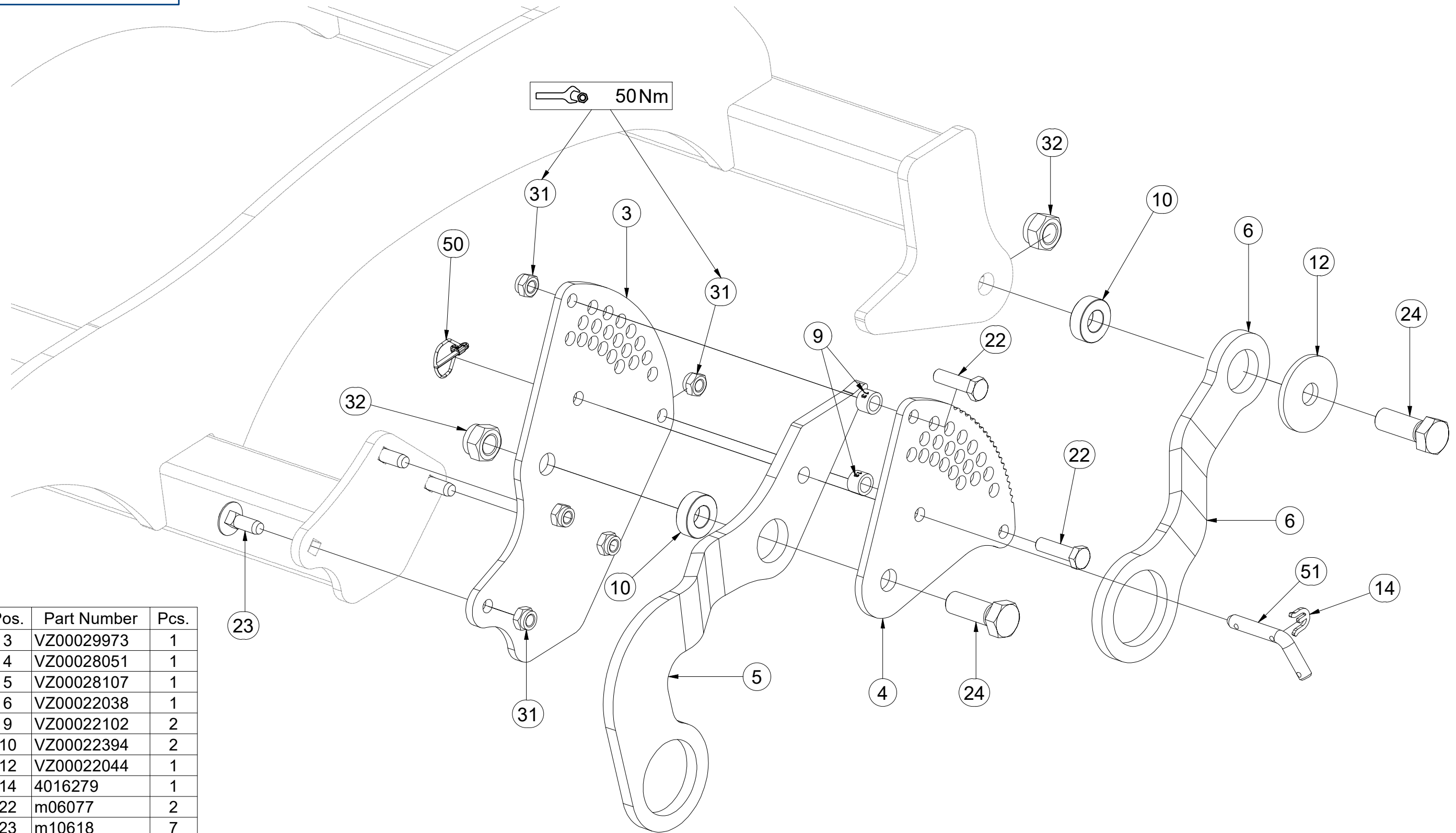

Pos.	Part Number	Pcs.
3	VZ00029973	1
4	VZ00028051	1
5	VZ00028107	1
6	VZ00022038	1
9	VZ00022102	2
10	VZ00022394	2
12	VZ00022044	1
14	4016279	1
22	m06077	2
23	m10618	7
24	m12771	2
31	m04301	9
32	m05648	2
50	m10454	1
51	m09141	1

CZ DEFLEKTOR PRAVÝ
 D DEFLEKTOR, RECHTER
 F DÉFLECTEUR DROIT

GB DEFLECTOR RIGHT
 RU ДЕФЛЕКТОР ПРАВЫЙ
 PL DEFLEKTOR PRAWY



VZ00036778

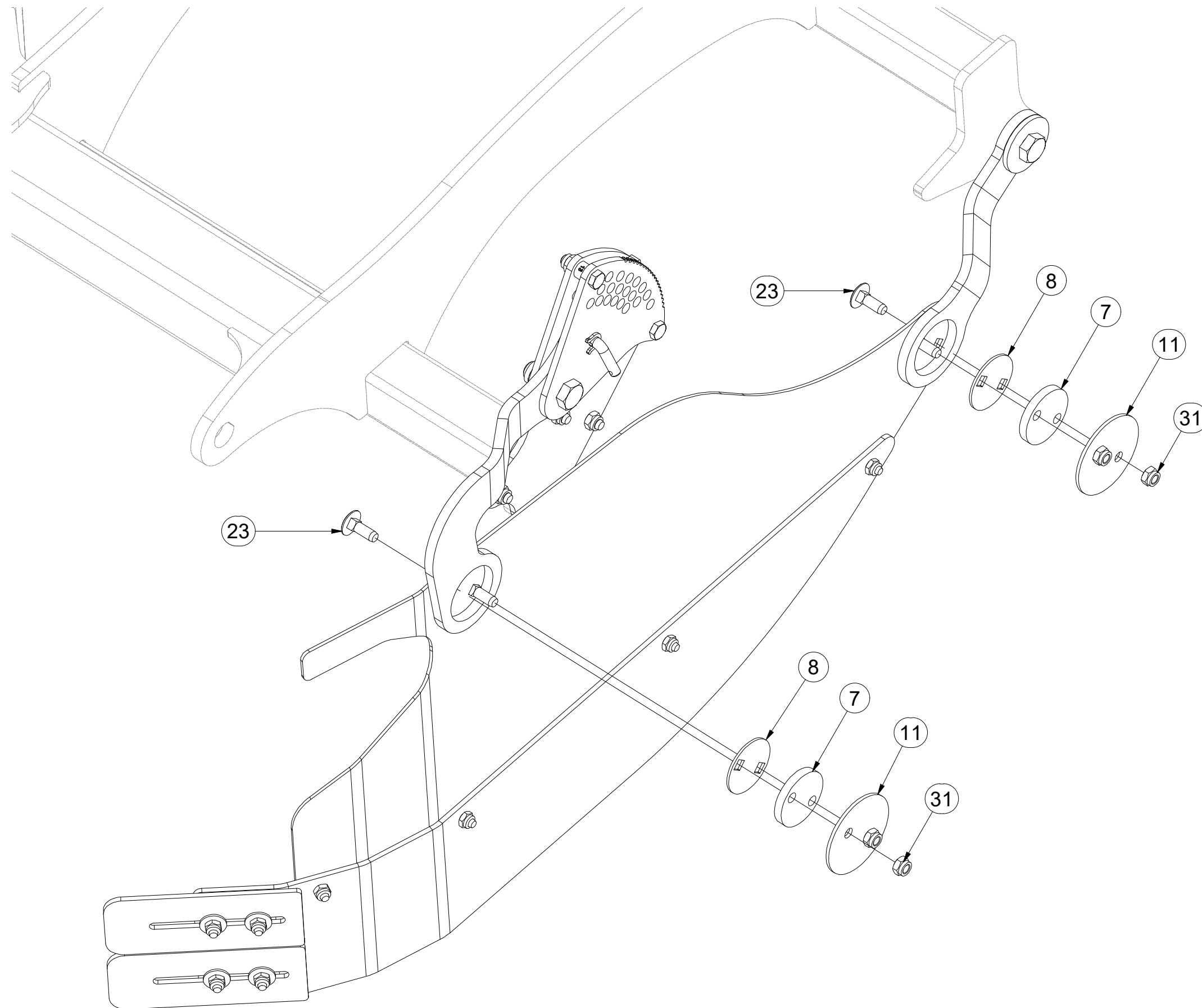

Pos.	Part Number	Pcs.
7	VZ00022395	2
8	VZ00022432	2
11	VZ00022433	2
23	m10618	7
31	m04301	9

Ⓒ SADA ZADNÍCH VÁLCŮ

Ⓓ SATZ HINTERE WALZEN

Ⓕ KIT DE ROULEAUX ARRIÈRE

VZ00036956

Ⓒ SET OF REAR ROLLERS

Ⓔ КОМПЛЕКТ ЗАДНИХ КАТКОВ

Ⓖ ZESTAW TYLNYCH WAŁÓW

Farmet

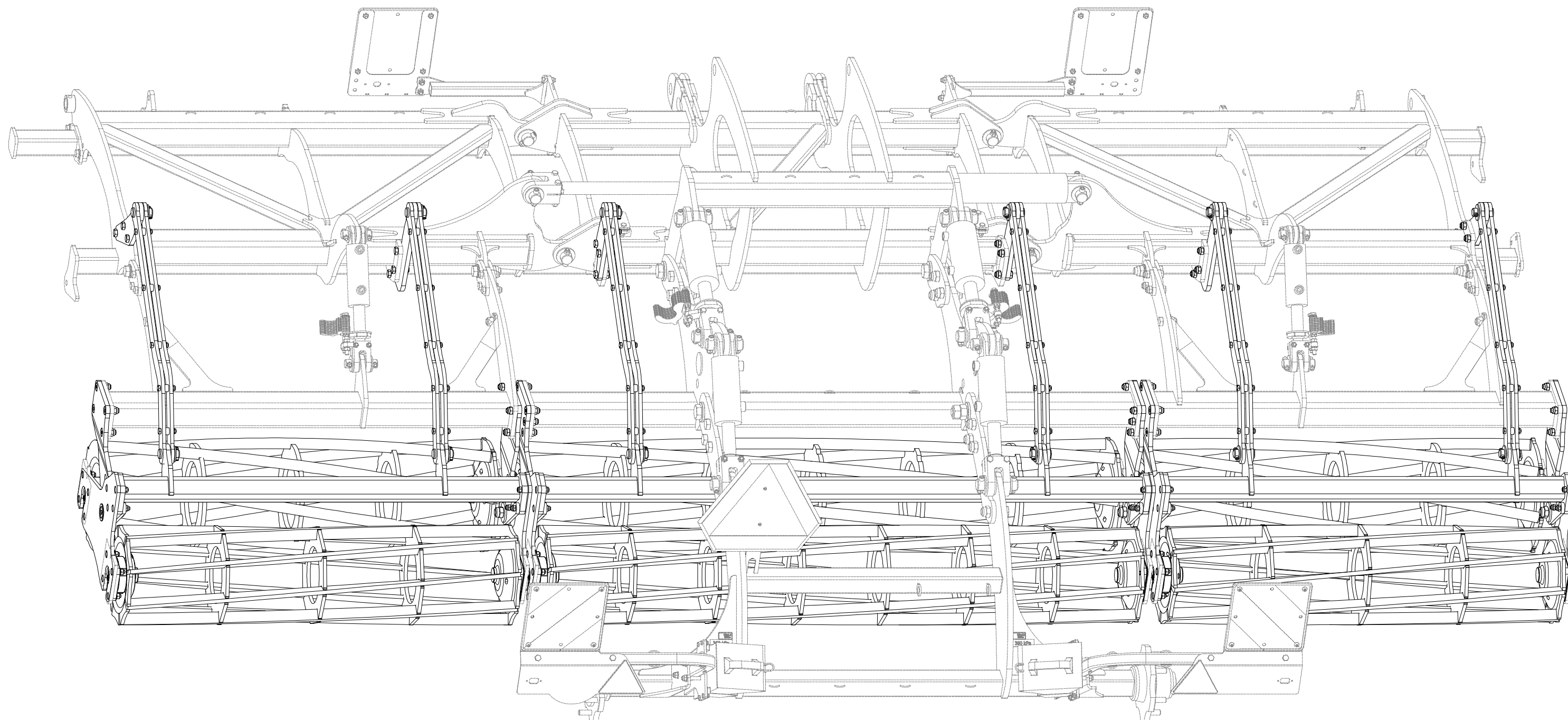

CZ SADA ZADNÍCH VÁLČŮ
 D SATZ HINTERE WALZEN
 F KIT DE ROULEAUX ARRIÈRE

GB SET OF REAR ROLLERS
 RU КОМПЛЕКТ ЗАДНИХ КАТКОВ
 PL ZESTAW TYLNYCH WAŁÓW



VZ00036956

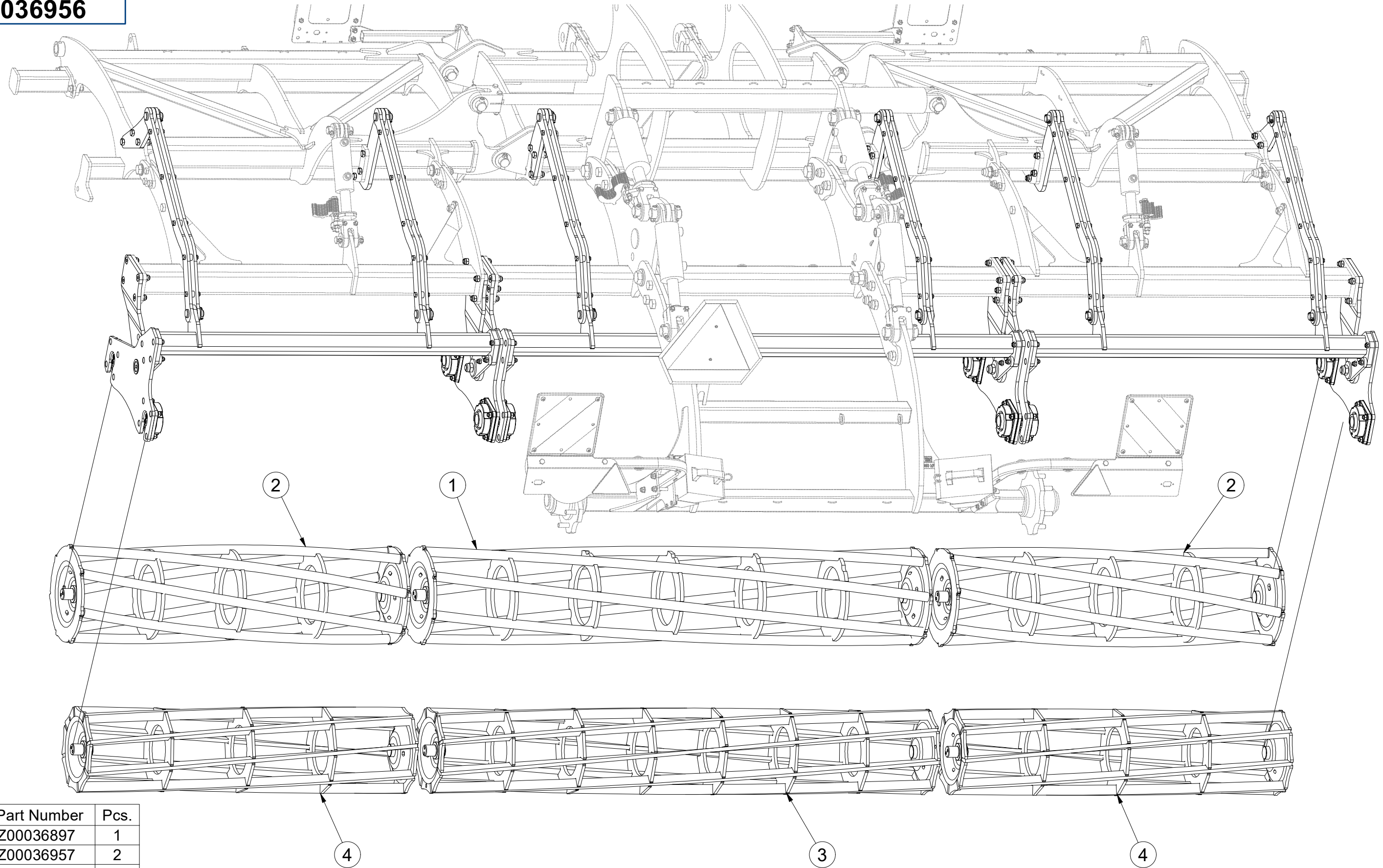

Pos.	Part Number	Pcs.
1	VZ00036897	1
2	VZ00036957	2
3	VZ00036906	1
4	VZ00036958	2

CZ SADA ZADNÍCH VÁLCŮ
 D SATZ HINTERE WALZEN
 F KIT DE ROULEAUX ARRIÈRE

GB SET OF REAR ROLLERS
 RU КОМПЛЕКТ ЗАДНИХ КАТКОВ
 PL ZESTAW TYLNYCH WAŁÓW



VZ00036956

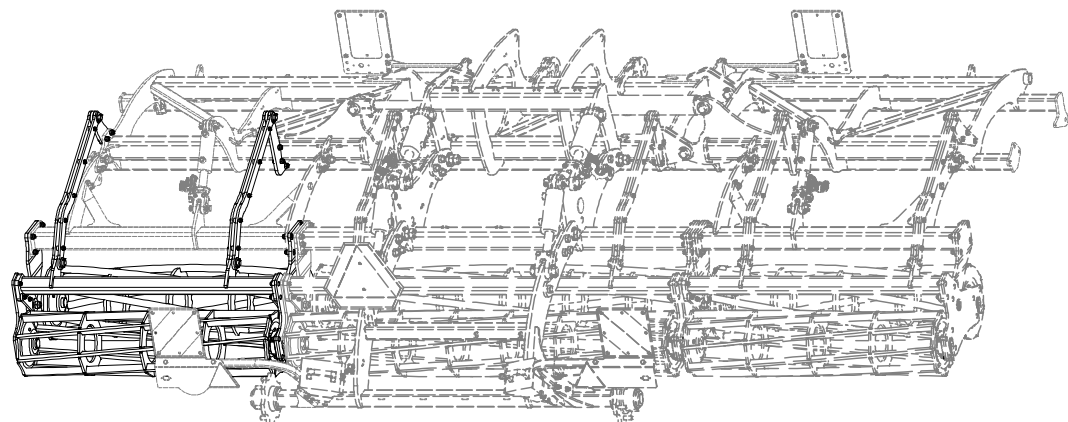
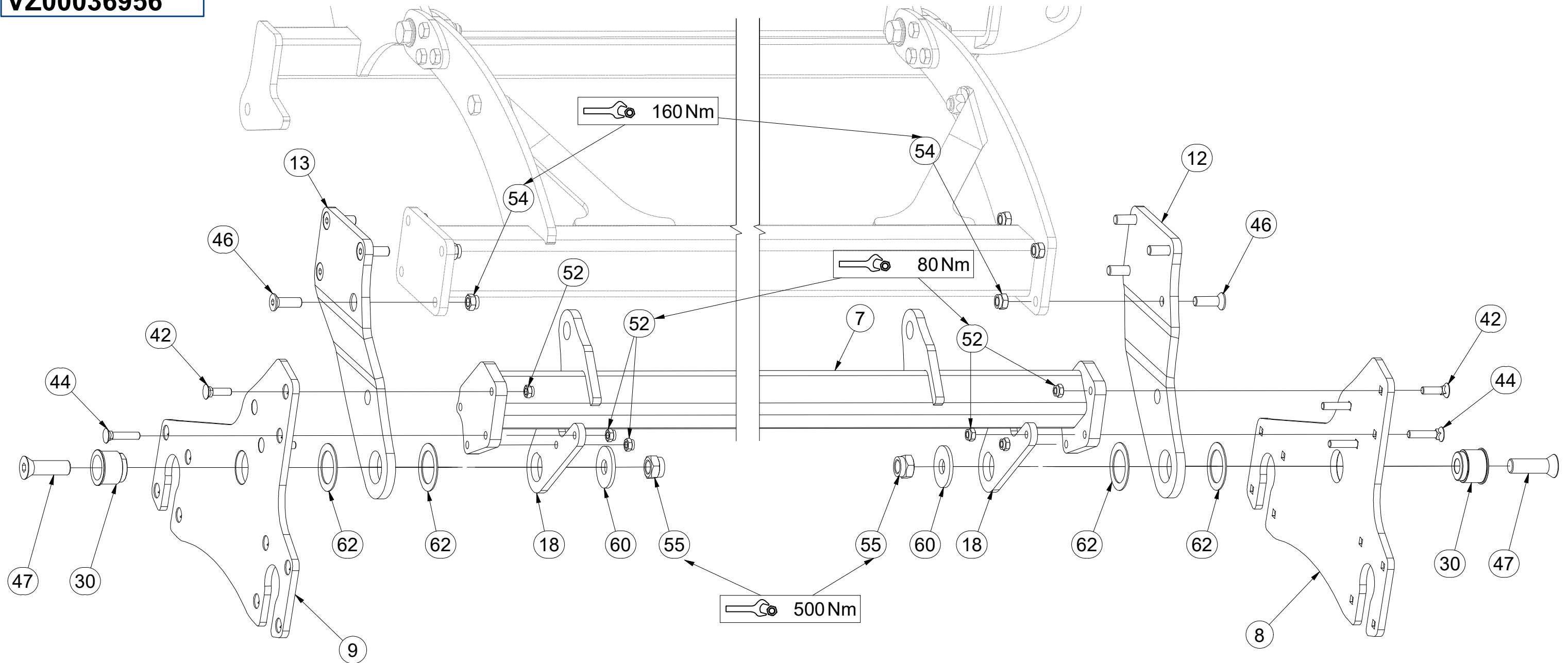

Pos.	Part Number	Pcs.	Pos.	Part Number	Pcs.
7	VZ00017083	1	44	m19365	18
8	VZ00019354	3	46	m14672	28
9	VZ00019355	3	47	m14992	6
12	3008702	2	52	m04301	24
13	3008700	2	54	m03683	28
18	4015769	6	55	m07147	6
30	m14991	6	60	4015792	6
42	m19364	6	62	VZ00003521	12

CZ SADA ZADNÍCH VÁLCŮ
 D SATZ HINTERE WALZEN
 F KIT DE ROULEAUX ARRIÈRE

GB SET OF REAR ROLLERS
 RU КОМПЛЕКТ ЗАДНИХ КАТКОВ
 PL ZESTAW TYLNYCH WAŁÓW



VZ00036956

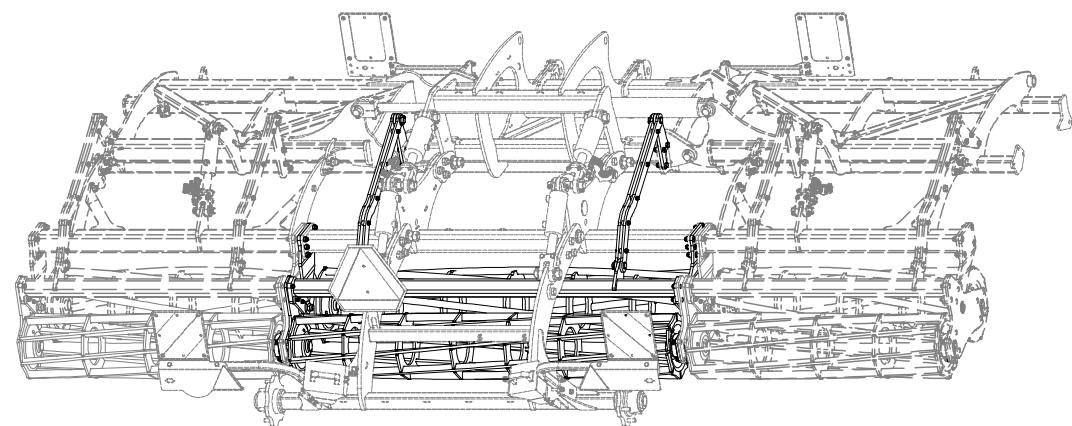
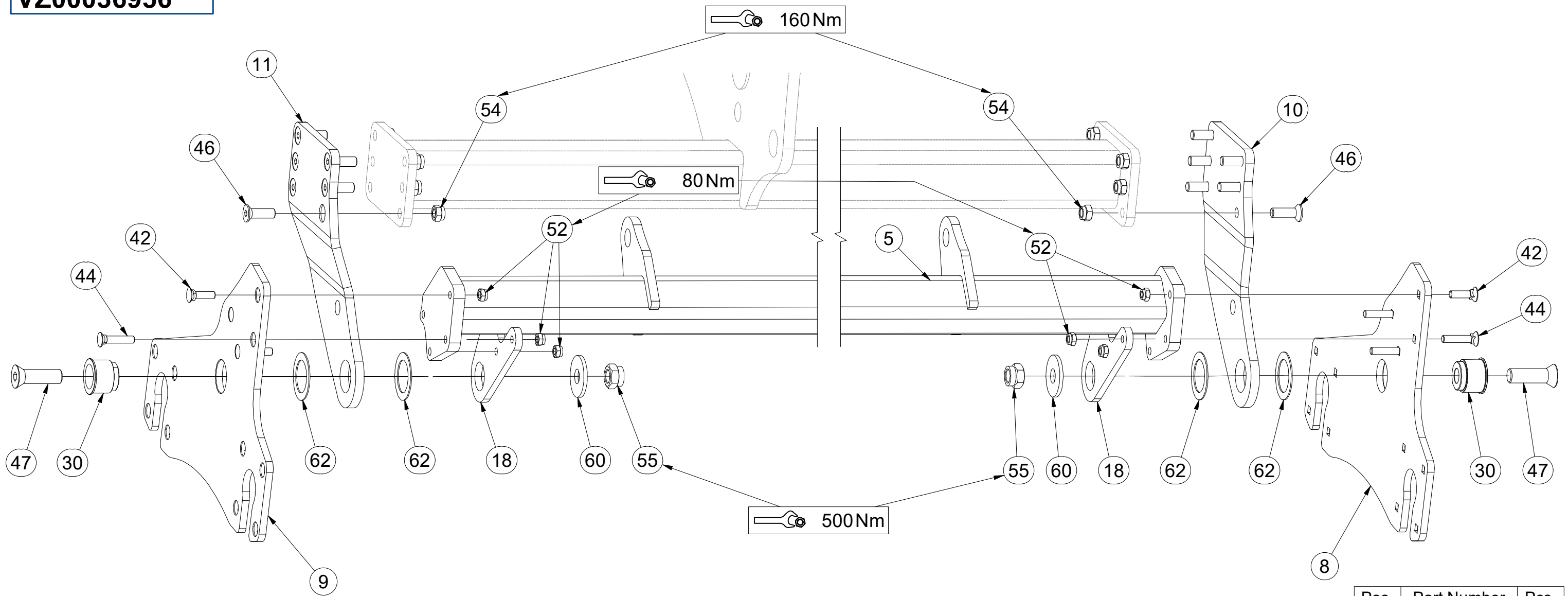

Pos.	Part Number	Pcs.
5	VZ00016541	1
8	VZ00019354	3
9	VZ00019355	3
10	3008703	1
11	3008701	1
18	4015769	6
60	4015792	6
30	m14991	6
42	m19364	6
44	m19365	18
46	m14672	28
47	m14992	6
52	m04301	24
54	m03683	28
55	m07147	6
62	VZ00003521	12

CZ SADA ZADNÍCH VÁLČŮ
 D SATZ HINTERE WALZEN
 F KIT DE ROULEAUX ARRIÈRE

GB SET OF REAR ROLLERS
 RU КОМПЛЕКТ ЗАДНИХ КАТКОВ
 PL ZESTAW TYLNYCH WAŁÓW



VZ00036956

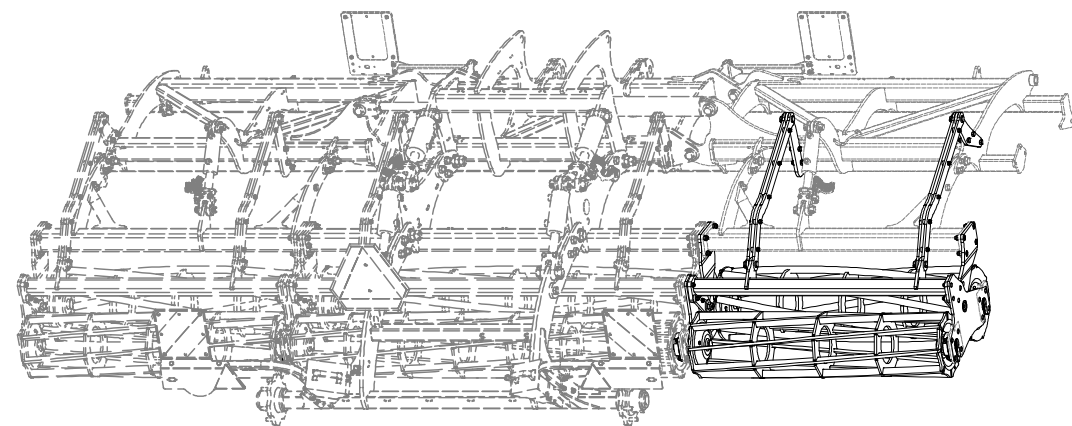
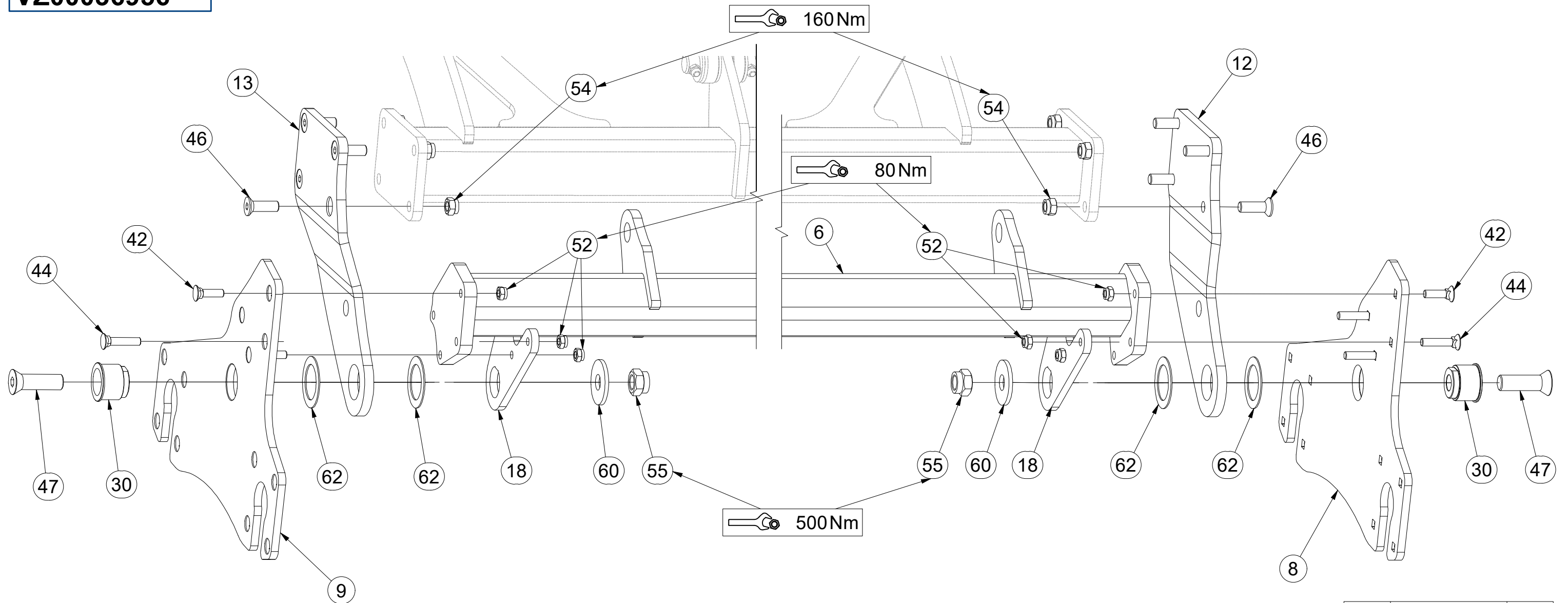

Pos.	Part Number	Pcs.
6	VZ00017090	1
8	VZ00019354	3
12	3008702	2
13	3008700	2
18	4015769	6
60	4015792	6
30	m14991	6
42	m19364	6
44	m19365	18
46	m14672	28
47	m14992	6
52	m04301	24
54	m03683	28
55	m07147	6
62	VZ00003521	12

Ⓒ SADA ZADNÍCH VÁLCŮ

Ⓓ SATZ HINTERE WALZEN

Ⓕ KIT DE ROULEAUX ARRIÈRE

Ⓖ SET OF REAR ROLLERS

Ⓡ КОМПЛЕКТ ЗАДНИХ КАТКОВ

Ⓟ ZESTAW TYLNYCH WAŁÓW

Farmet

VZ00036956

Pos.	Part Number	Pcs.
14	VZ00016554	6
16	VZ00004654	2
17	VZ00004648	2
19	4025823	12
40	m13894	12
45	m10849	18
50	m04503	12
53	m20385	18
61	m14029	12

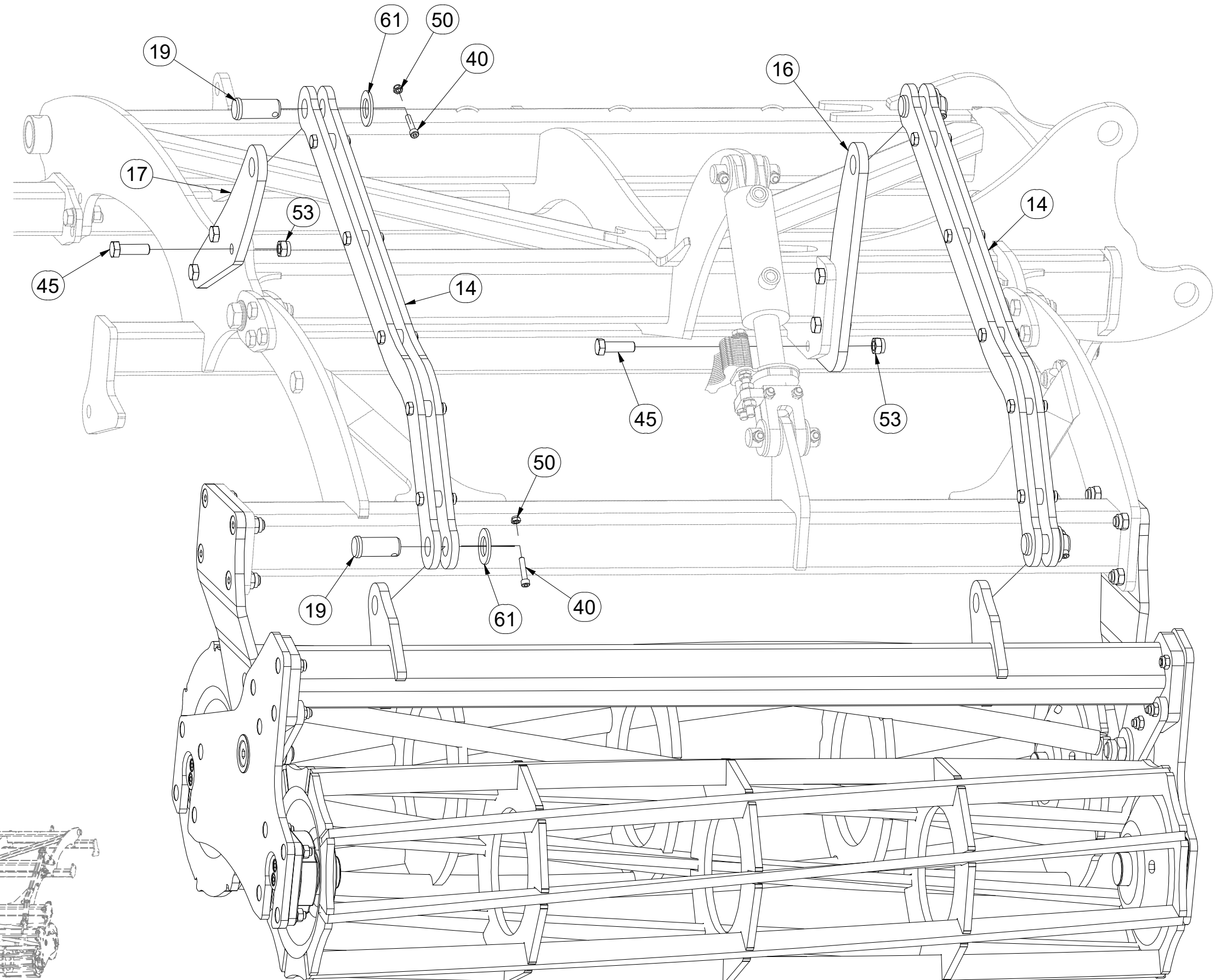
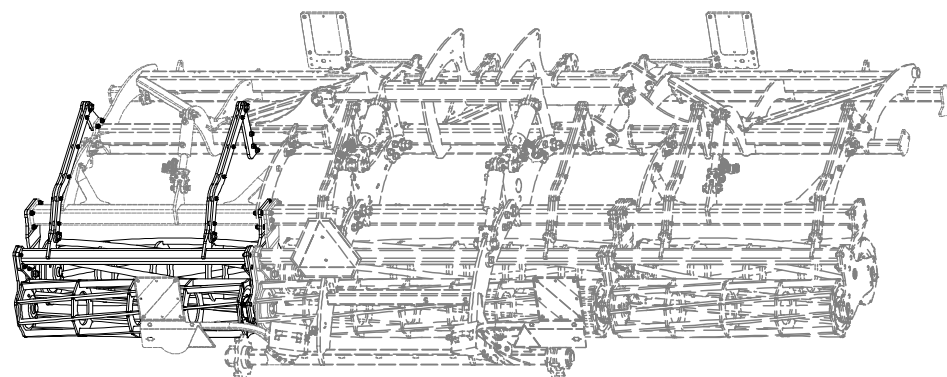

CZ SADA ZADNÍCH VÁLČŮ
 D SATZ HINTERE WALZEN
 F KIT DE ROULEAUX ARRIÈRE

GB SET OF REAR ROLLERS
 RU КОМПЛЕКТ ЗАДНИХ КАТКОВ
 PL ZESTAW TYLNYCH WAŁÓW



VZ00036956

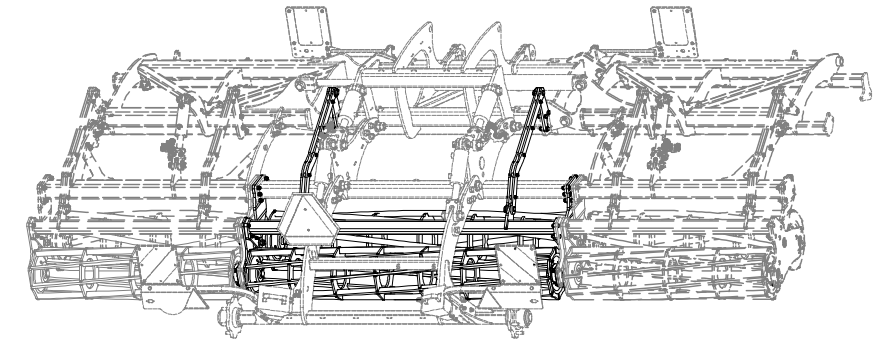
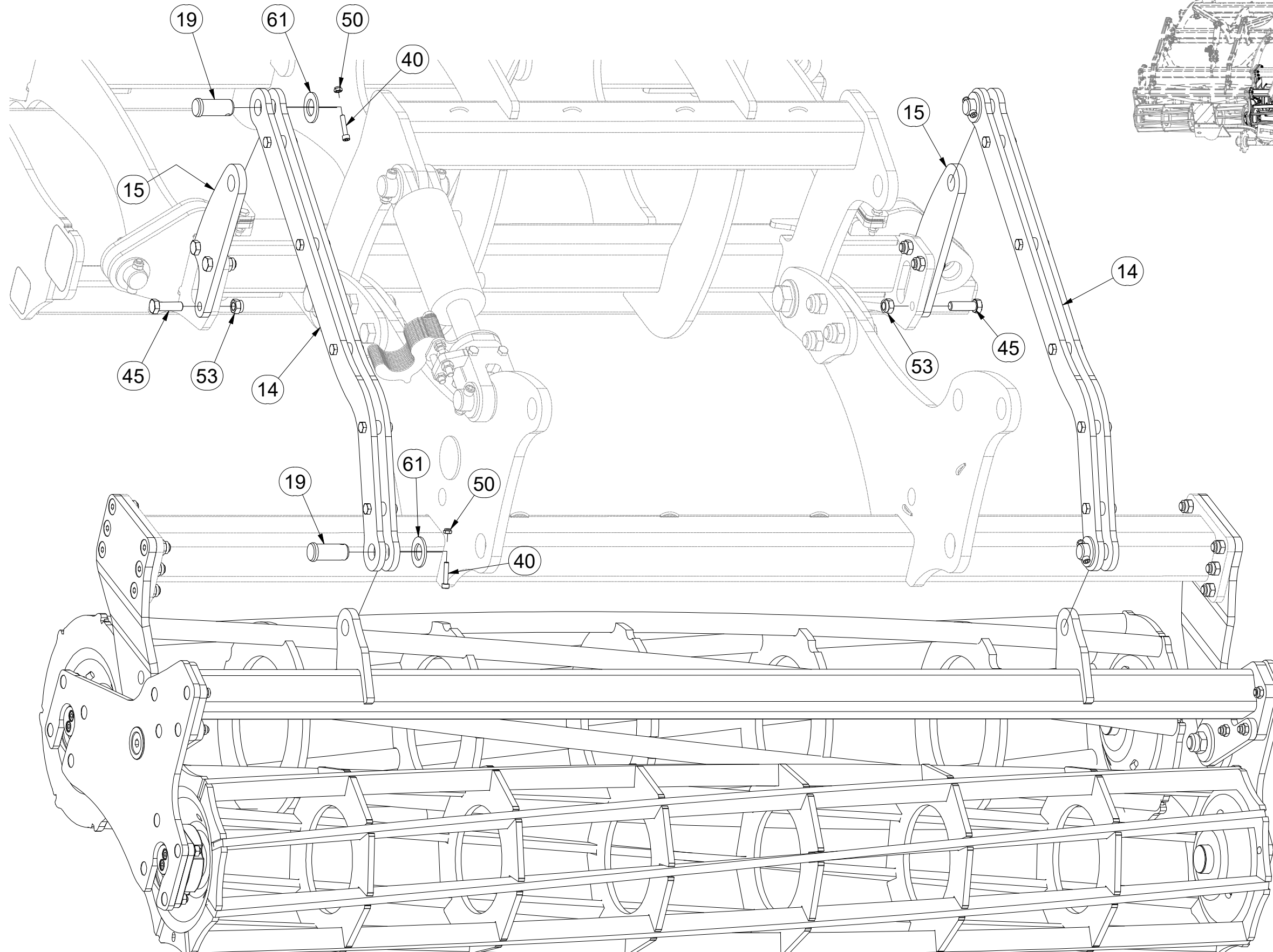

Pos.	Part Number	Pcs.
14	VZ00016554	6
15	VZ00004639	2
19	4025823	12
40	m13894	12
45	m10849	18
50	m04503	12
53	m20385	18
61	m14029	12

CZ SADA ZADNÍCH VÁLCŮ
 D SATZ HINTERE WALZEN
 F KIT DE ROULEAUX ARRIÈRE

GB SET OF REAR ROLLERS
 RU КОМПЛЕКТ ЗАДНИХ КАТКОВ
 PL ZESTAW TYLNYCH WAŁÓW



VZ00036956

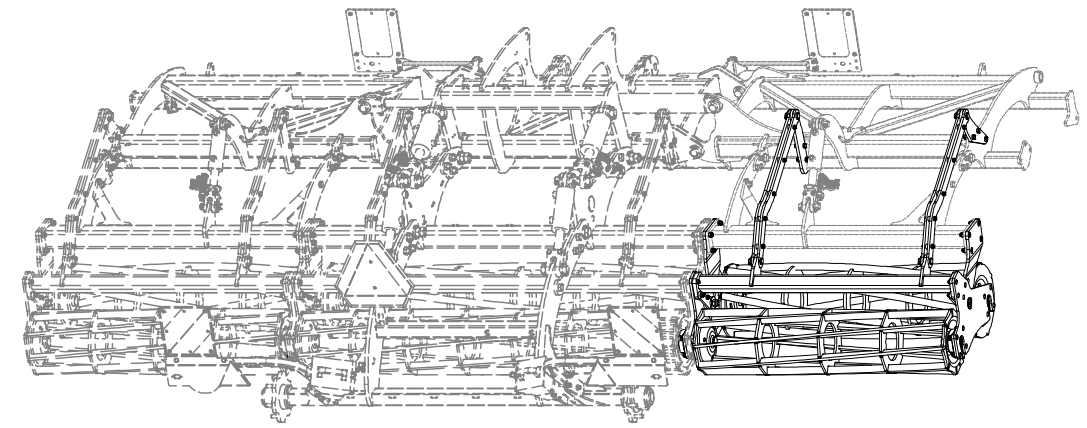
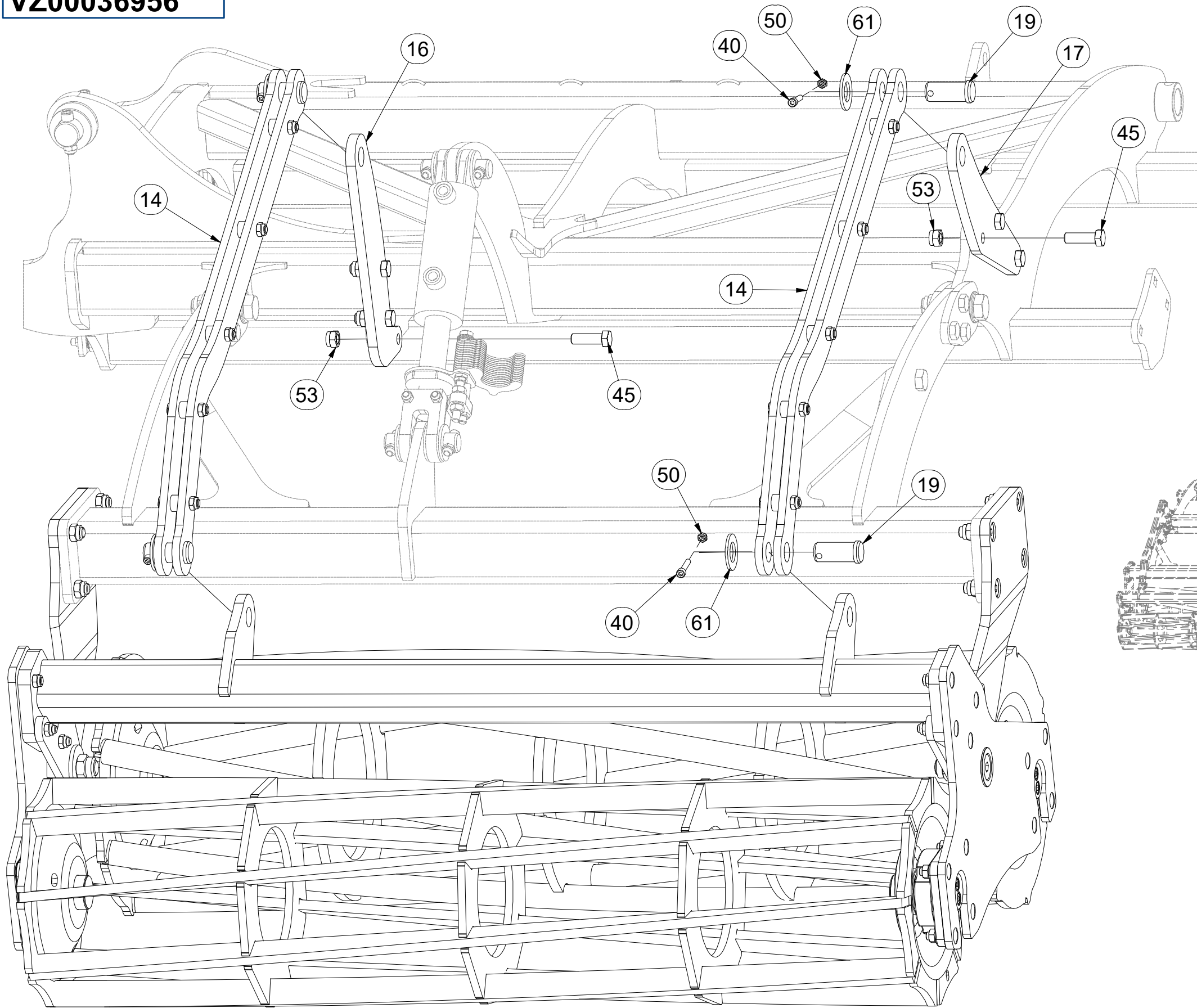

Pos.	Part Number	Pcs.
14	VZ00016554	6
16	VZ00004654	2
17	VZ00004648	2
19	4025823	12
40	m13894	12
45	m10849	18
50	m04503	12
53	m20385	18
61	m14029	12

CZ SADA ZADNÍCH VÁLCŮ
 D SATZ HINTERE WALZEN
 F KIT DE ROULEAUX ARRIÈRE

GB SET OF REAR ROLLERS
 RU КОМПЛЕКТ ЗАДНИХ КАТКОВ
 PL ZESTAW TYLNYCH WAŁÓW



VZ00036956

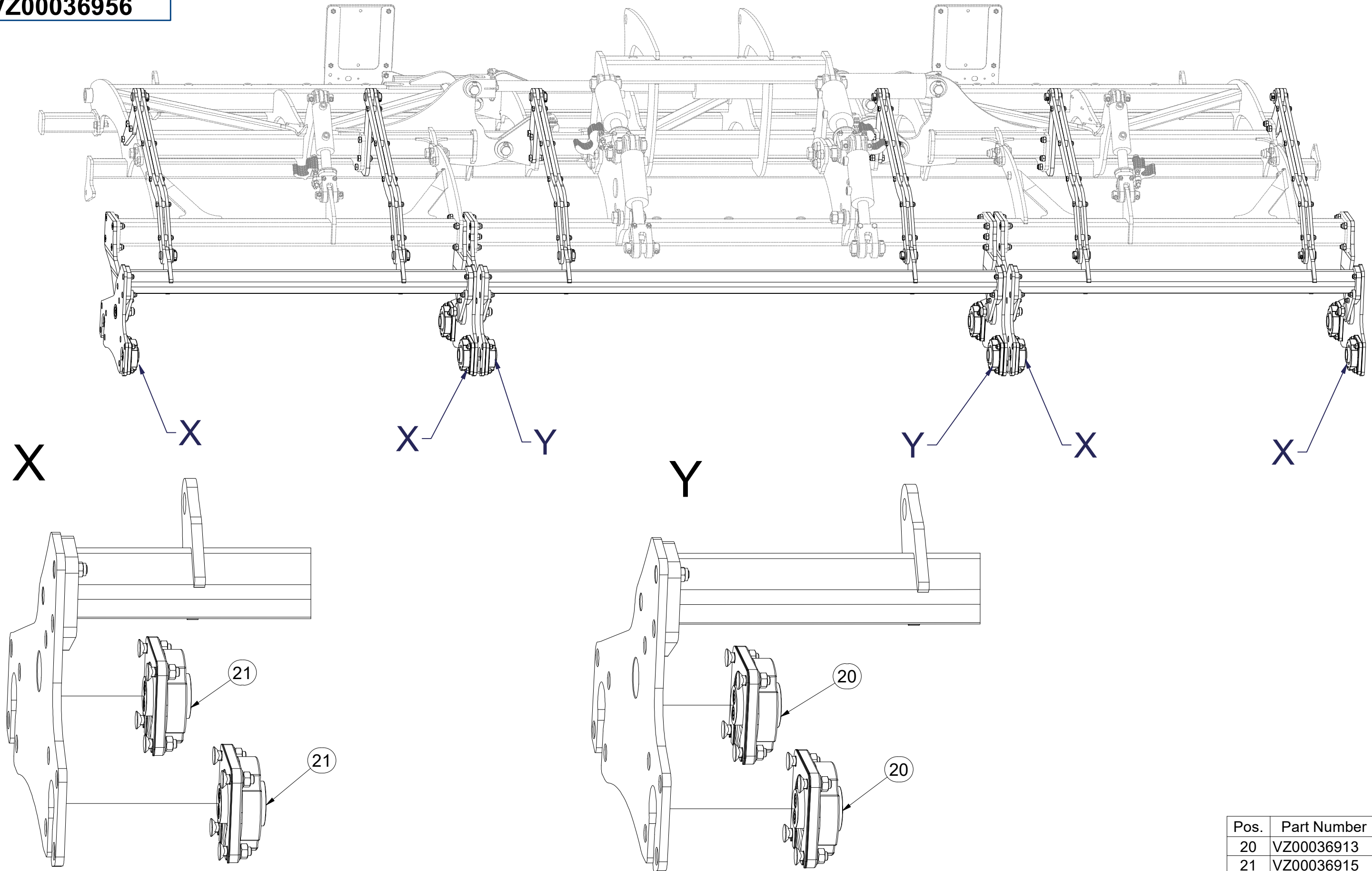

Pos.	Part Number	Pcs.
20	VZ00036913	4
21	VZ00036915	8

CZ TÁHLO
 D STANGE
 F TIGE DE TRACTION

GB DRAWBAR
 RU ТЯГА
 PL PRĘT



VZ00016554

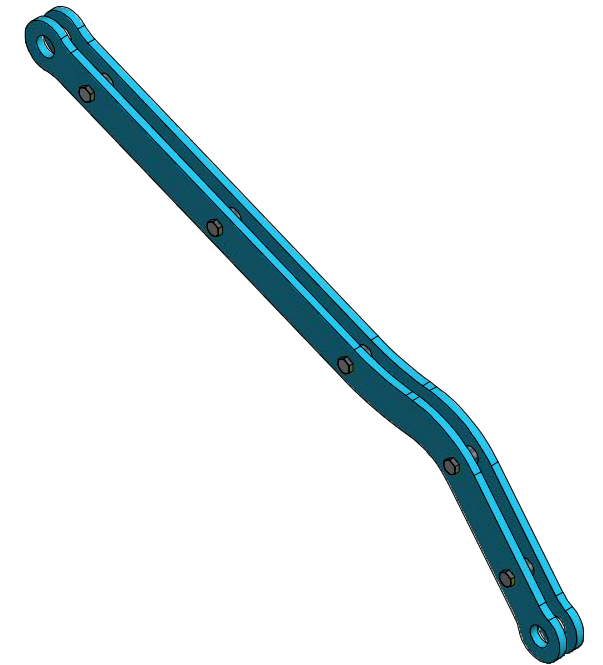
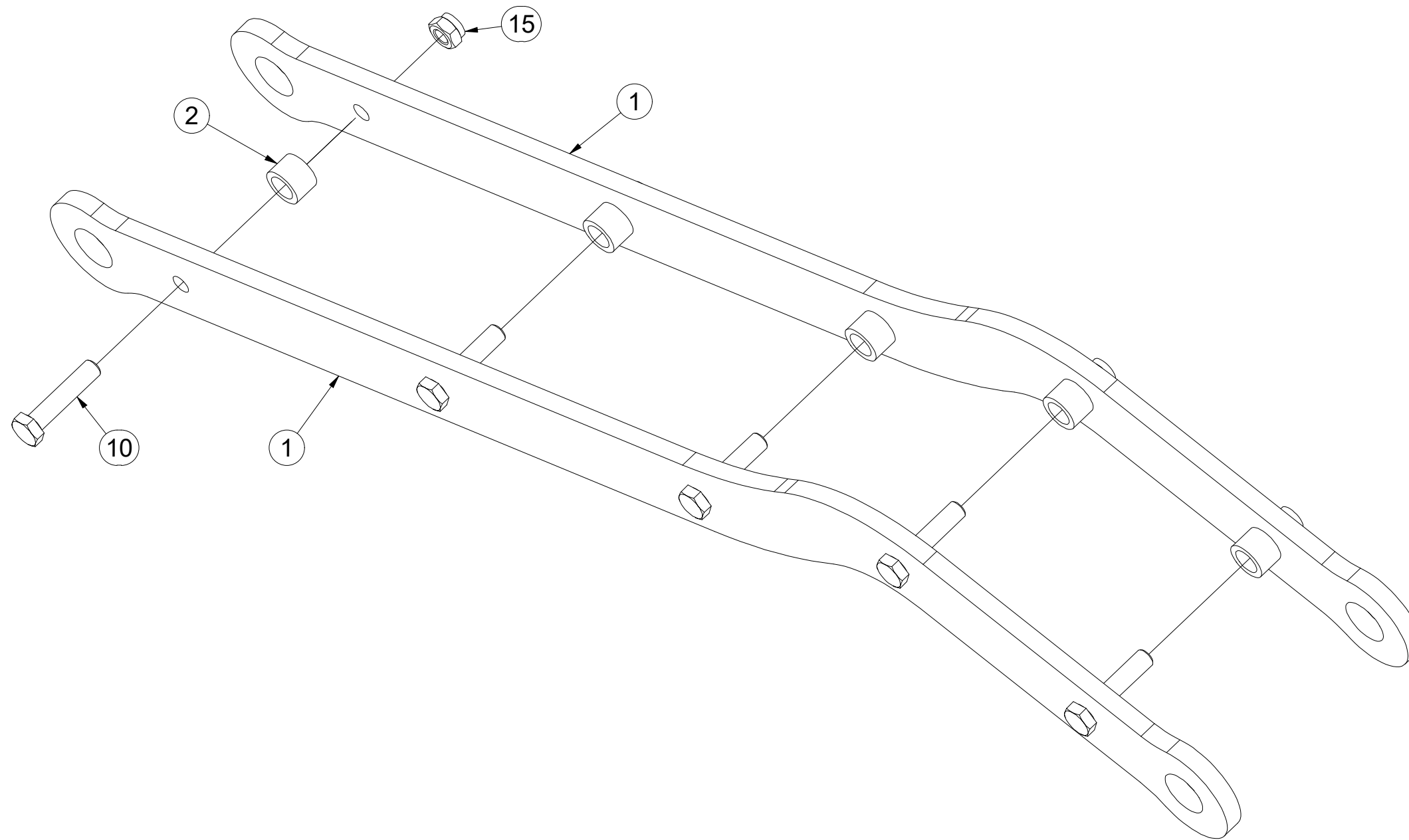

Pos.	Part Number	Pcs.
1	VZ00016555	2
2	4006690	5
10	m04412	5
15	m04301	5

- Ⓒ SADA LOŽISEK
- Ⓓ SATZ LAGER
- Ⓕ KIT DE ROULEMENTS

- Ⓖ SET OF BEARINGS
- Ⓡ КОМПЛЕКТ ПОДШИПНИКОВ
- Ⓟ ZESTAW ŁOŻYSK



VZ00036913

Pos.	Part Number	Pcs.
1	VZ00038447	1
2	VZ00030606	3
10	m24607	1
11	m17545	4
12	m03988	2
14	m11154	4
15	m10439	4
16	m19122	2

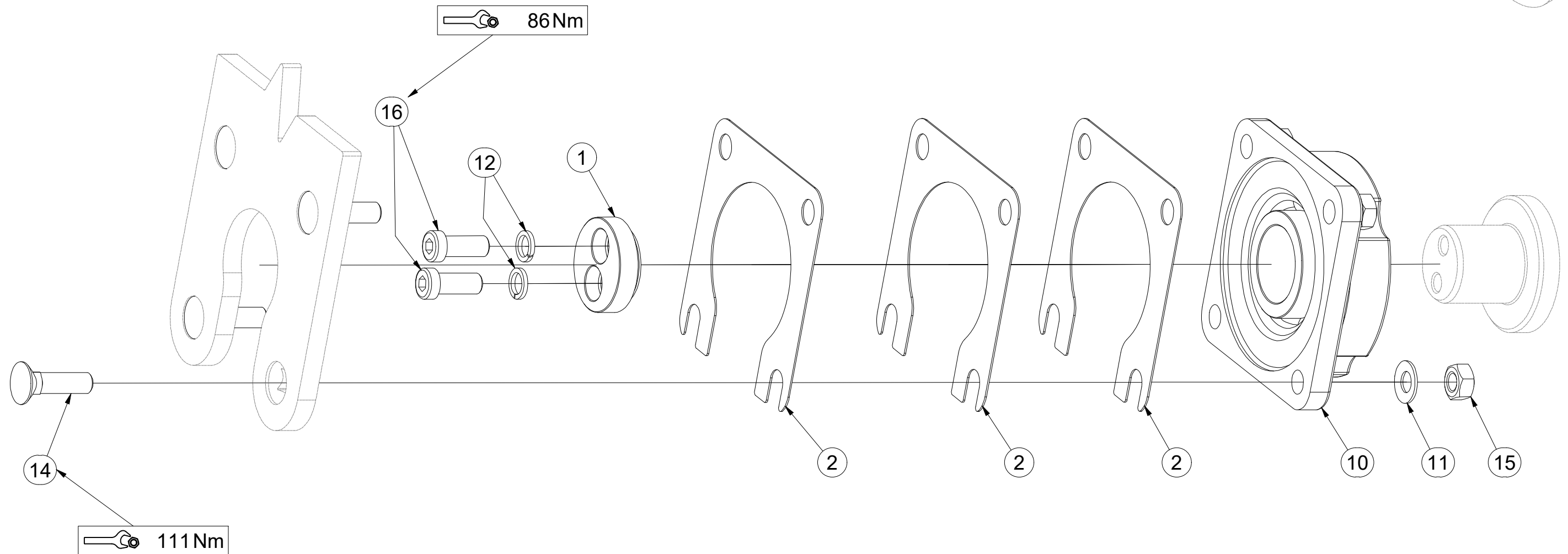
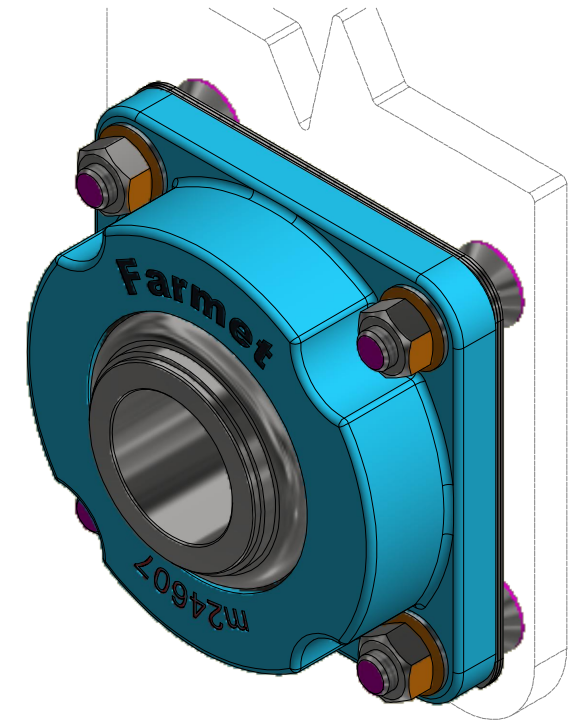

(CZ) SADA LOŽISEK
 (D) SATZ LAGER
 (F) KIT DE ROULEMENTS

(GB) SET OF BEARINGS
 (RU) КОМПЛЕКТ ПОДШИПНИКОВ
 (PL) ZESTAW ŁOŻYSK



VZ00036915

Pos.	Part Number	Pcs.
1	VZ00038447	1
2	VZ00030606	2
10	m24607	1
11	m17545	4
12	m03988	2
14	m11154	4
15	m10439	4
16	m19122	2

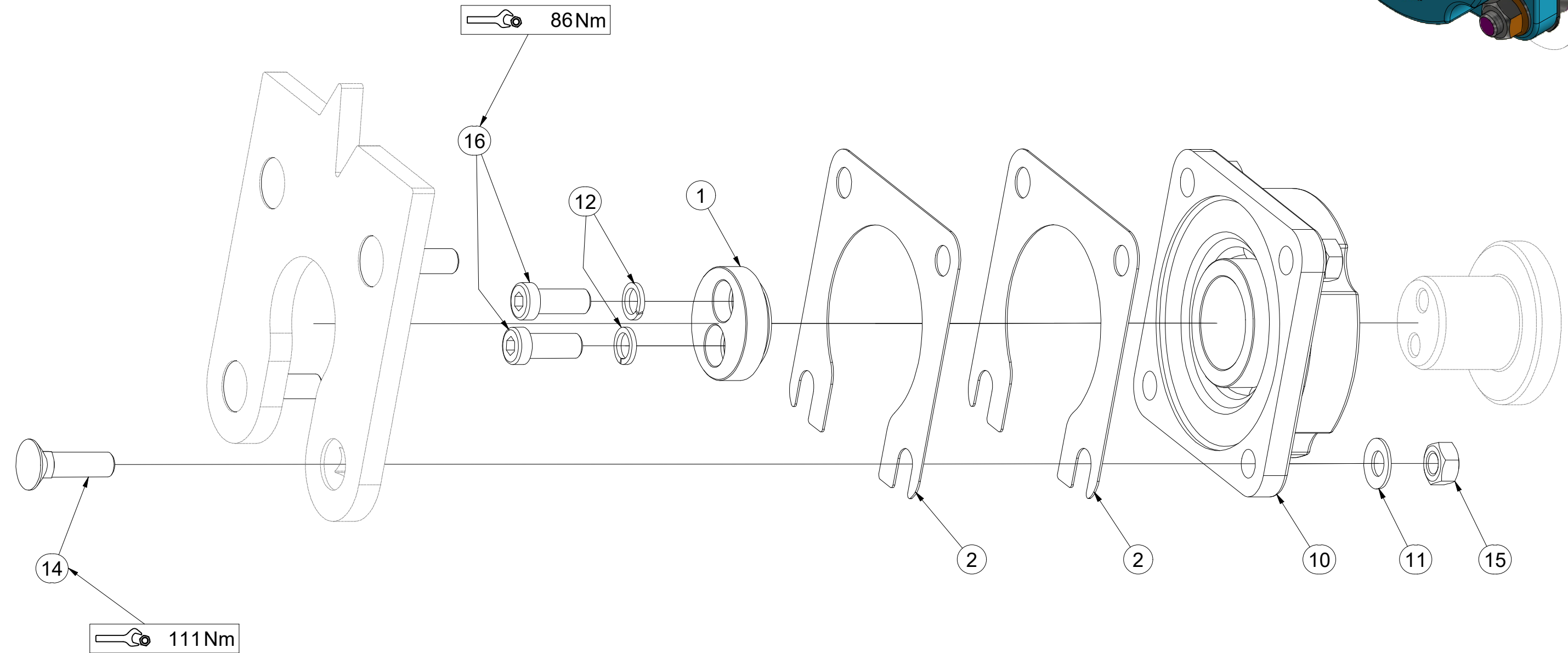
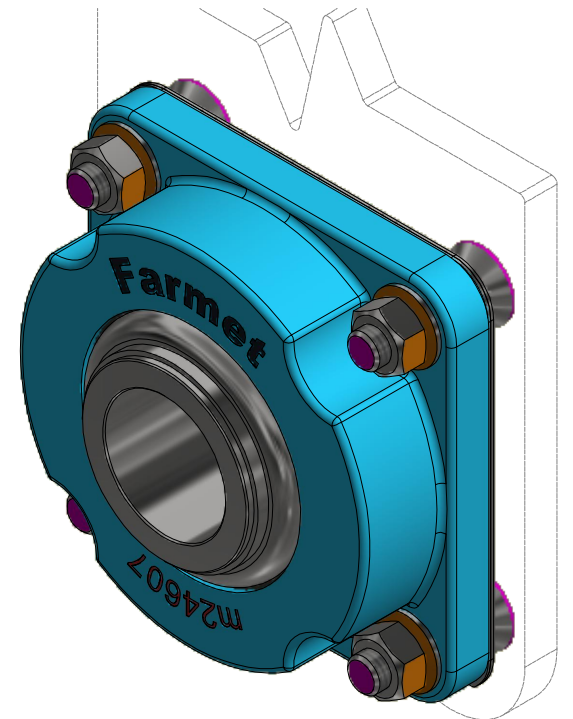

VZ00039937

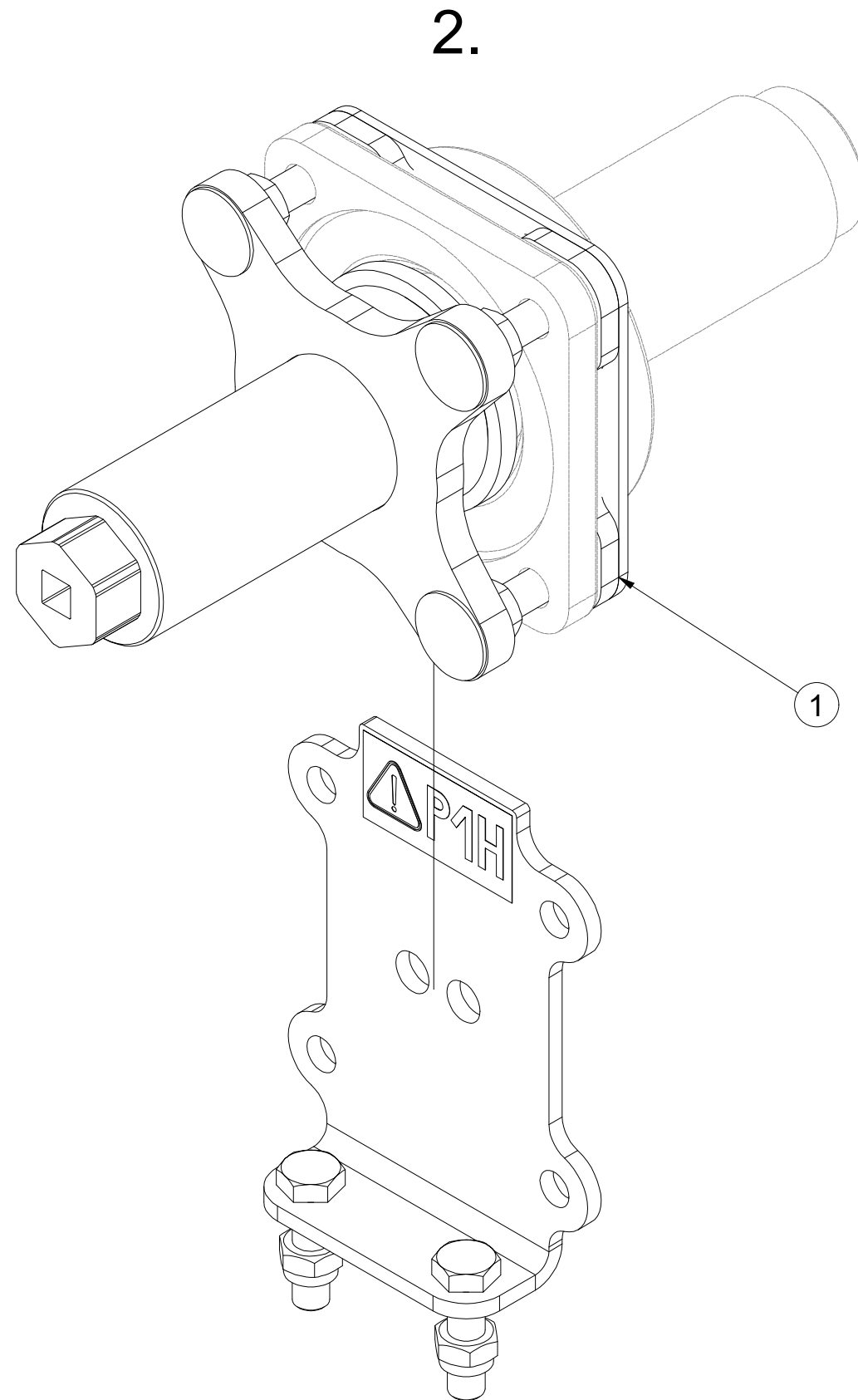
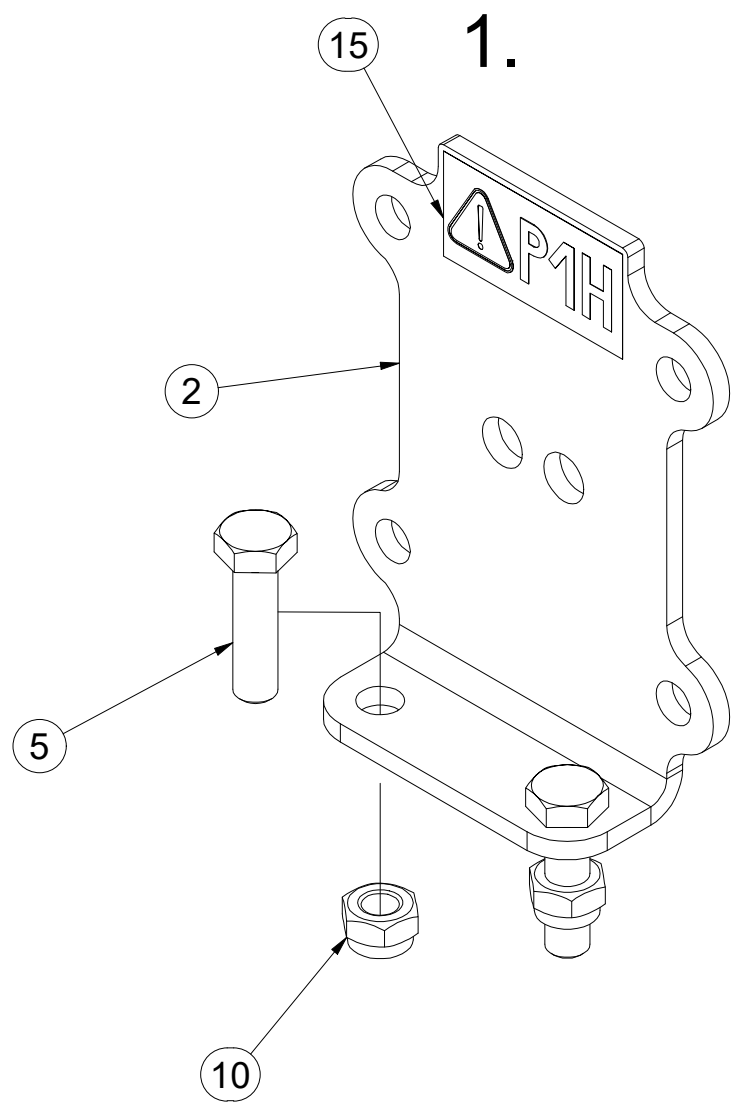

Pos.	Part Number	Pcs.
1	VZ00038848	1
2	VZ00039933	1
5	m06077	2
10	m04301	2
15	m04359	1

VZ00038848

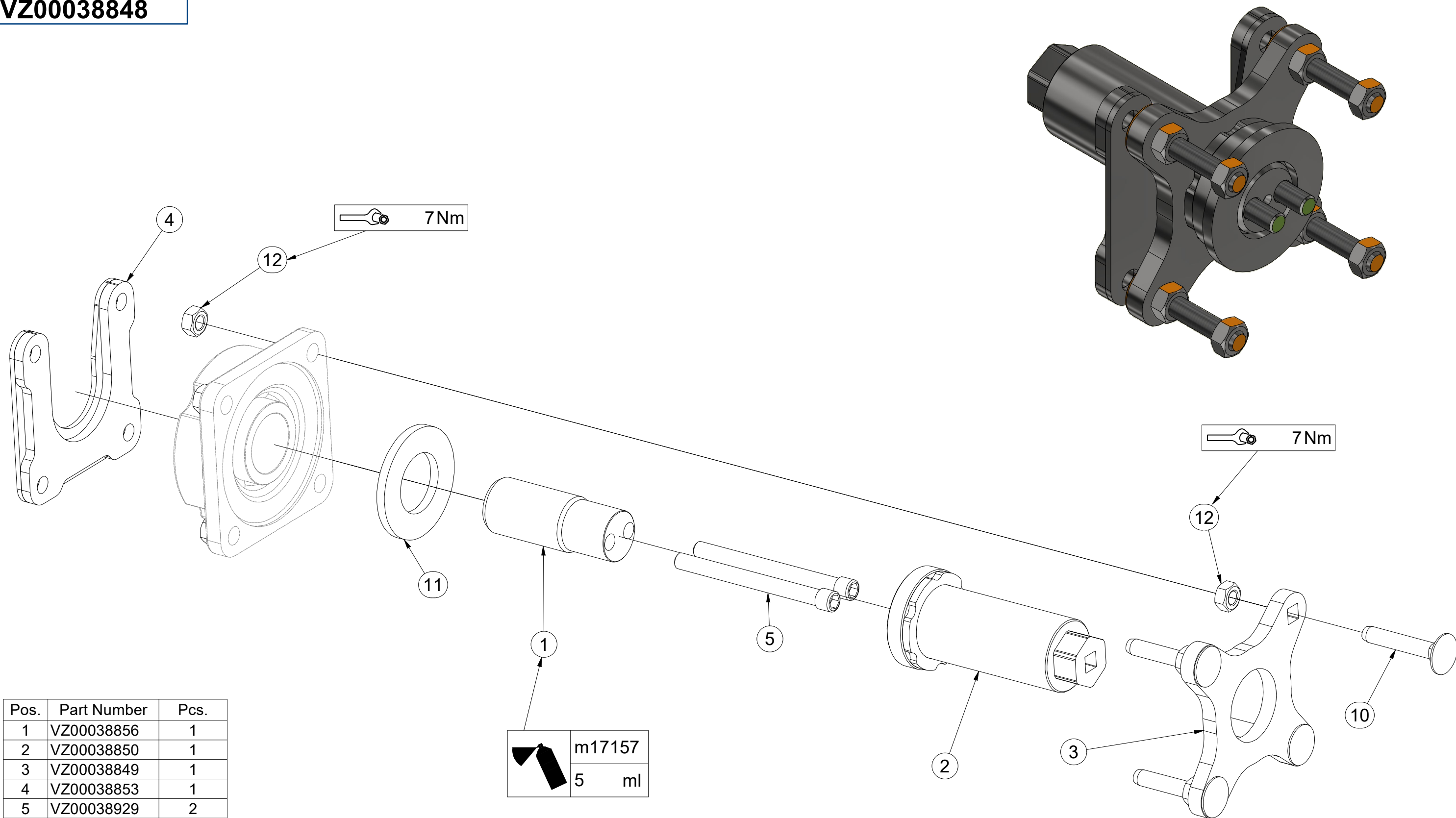

Pos.	Part Number	Pcs.
1	VZ00038856	1
2	VZ00038850	1
3	VZ00038849	1
4	VZ00038853	1
5	VZ00038929	2
10	m17684	4
11	m05447	1
12	m10439	8
20	m17157	5,00 ml

Ⓒ SADA NÁPRAVY

Ⓓ SATZ AUFHÄNGUNG

Ⓕ KIT DE L'ESSIEU

VZ00016126

Ⓖ AXLE SET

Ⓡ КОМПЛЕКТ ОСИ КОЛЁС

Ⓢ ZESTAW OSI

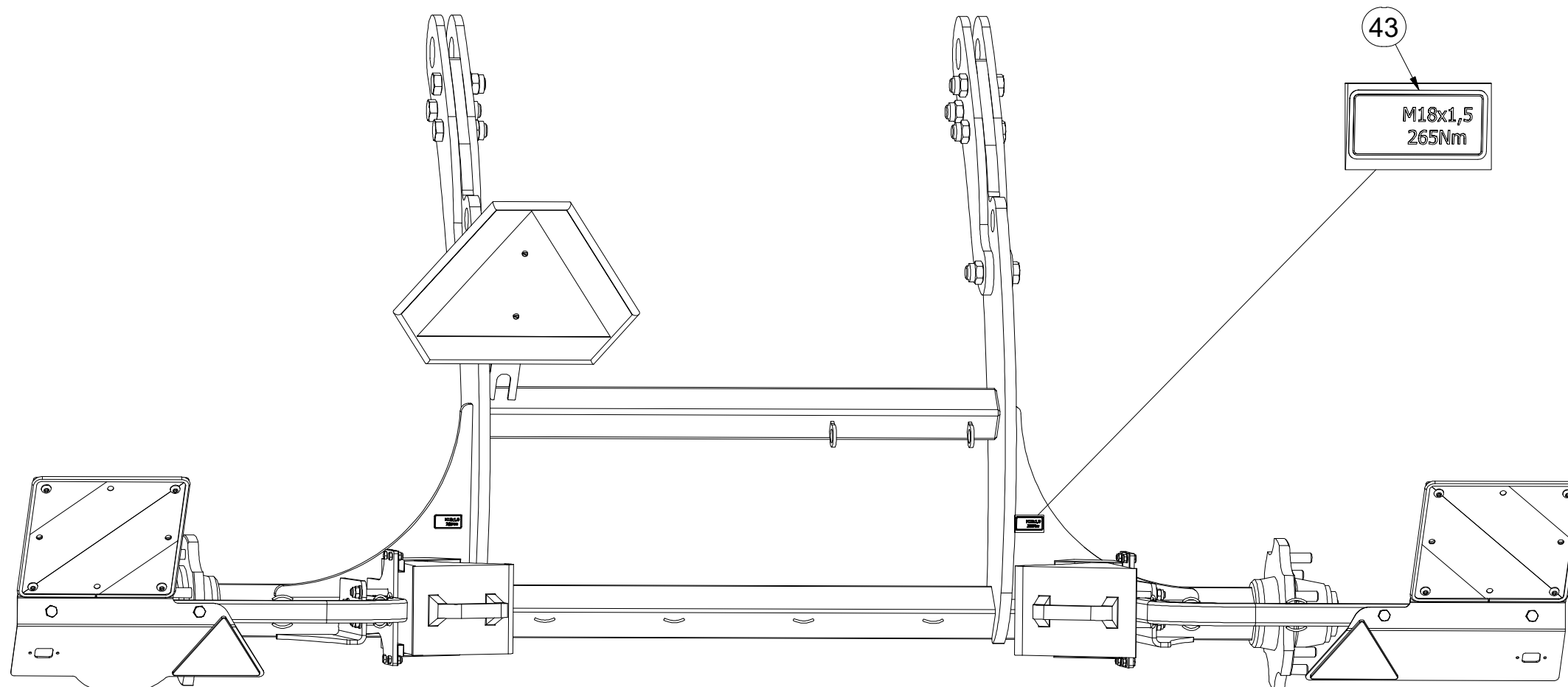
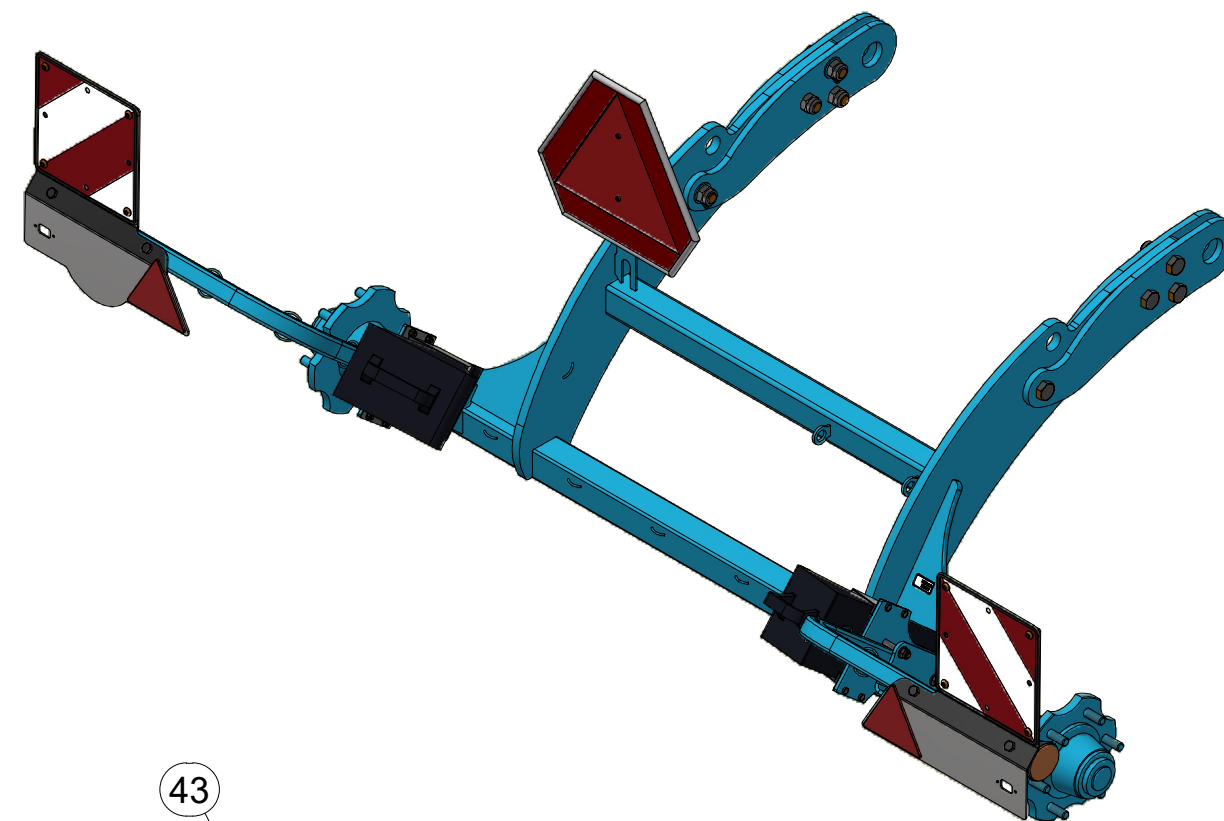

43
M18x1,5
265Nm

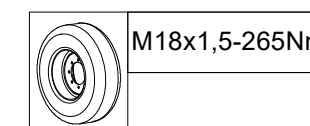

Pos.	Part Number	Pcs.
43	m19732	2

Ⓒ SADA NÁPRAVY

Ⓓ SATZ AUFHÄNGUNG

Ⓕ KIT DE L'ESSIEU

Ⓖ AXLE SET

Ⓡ КОМПЛЕКТ ОСИ КОЛЁС

Ⓟ ZESTAW OSI



VZ00016126

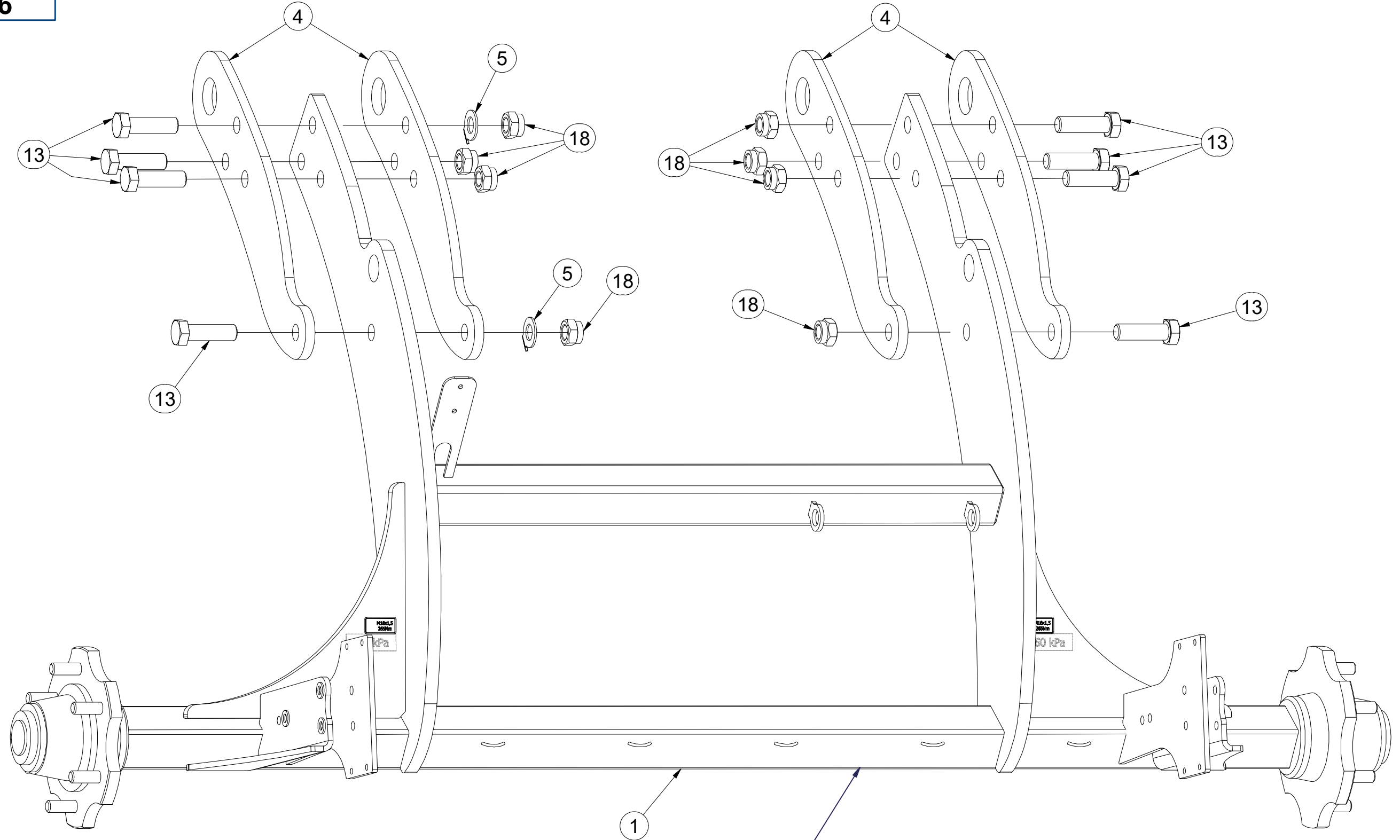

A70MR600N002

Pos.	Part Number	Pcs.	Pos.	Part Number	Pcs.
1	3011954	1	10	m01073	2
4	4015682	4	13	m14990	8
5	4015765	2	18	m07147	8

Ⓒ SADA NÁPRAVY

Ⓓ SATZ AUFHÄNGUNG

Ⓕ KIT DE L'ESSIEU

Ⓖ AXLE SET

Ⓡ КОМПЛЕКТ ОСИ КОЛЁС

Ⓢ ZESTAW OSI



VZ00016126

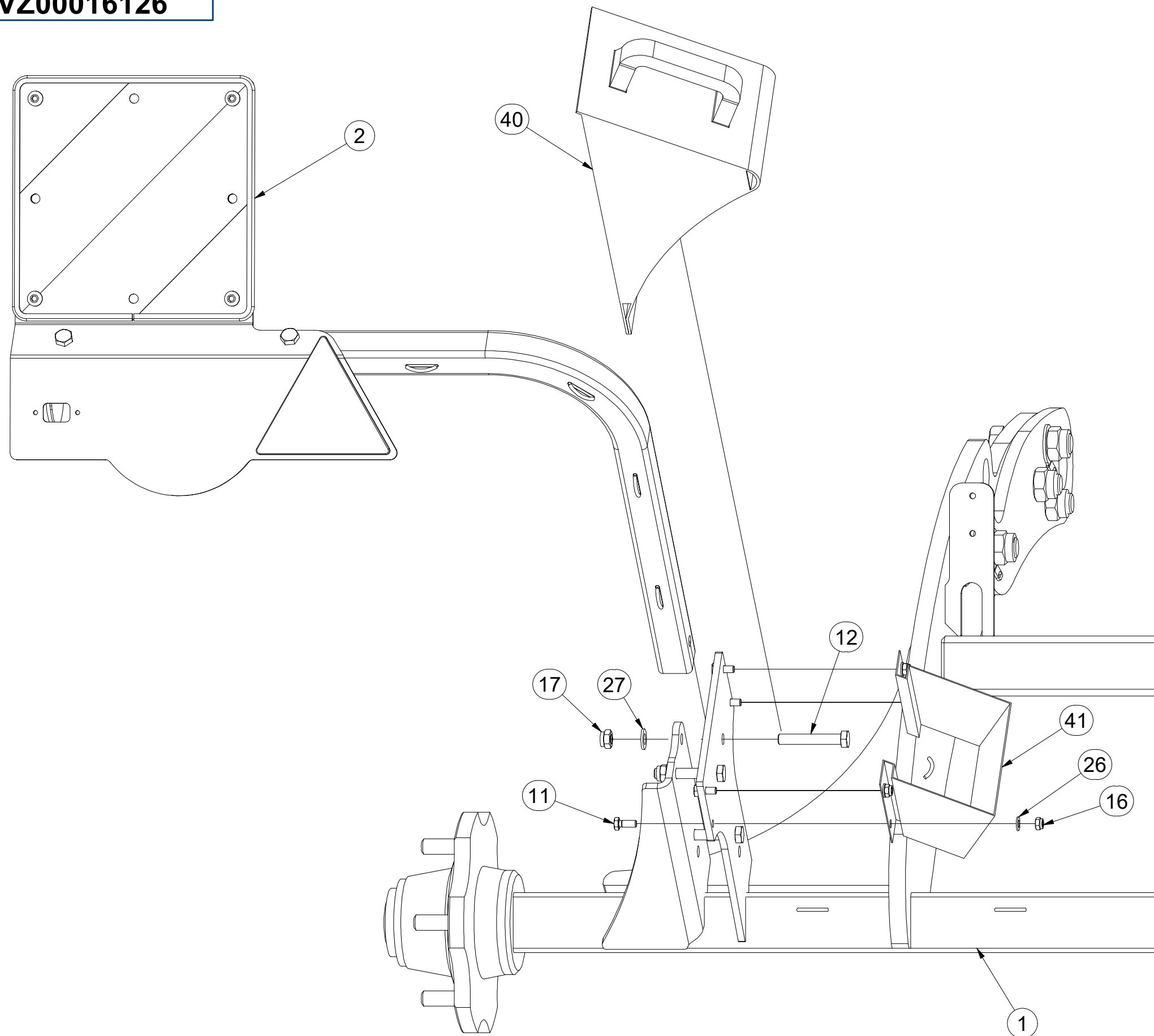

Pos.	Part Number	Pcs.
1	3011954	1
2	3012431	1
11	m01089	8
12	m12493	6
16	m04503	8
17	m04301	6
26	m01203	8
27	m01214	6
40	m16186	2
41	m12572	2

Ⓒ SADA NÁPRAVY

Ⓓ SATZ AUFHÄNGUNG

Ⓕ KIT DE L'ESSIEU

Ⓖ AXLE SET

Ⓡ КОМПЛЕКТ ОСИ КОЛЁС

Ⓢ ZESTAW OSI



VZ00016126

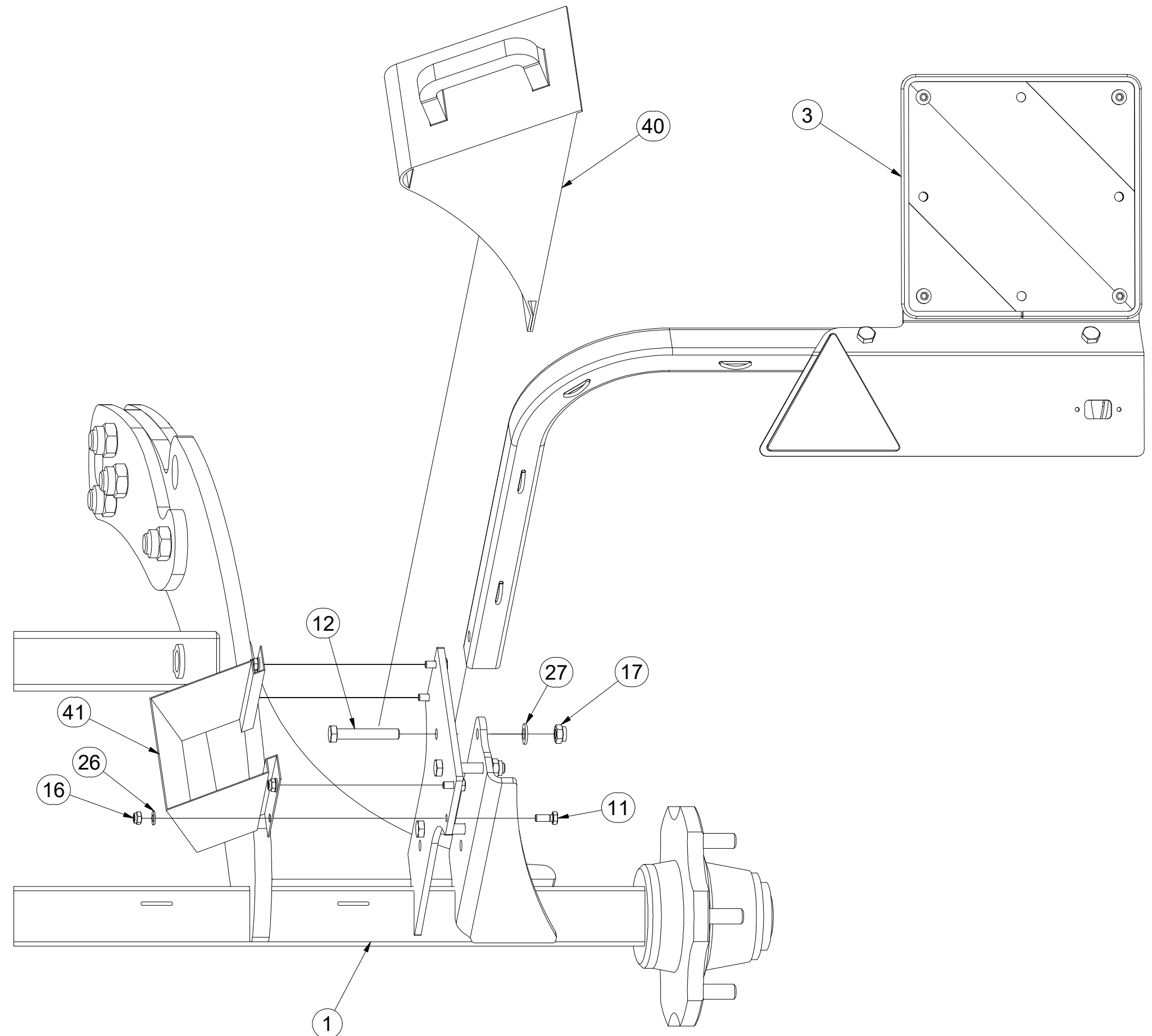

Pos.	Part Number	Pcs.
1	3011954	1
3	3012432	1
11	m01089	8
12	m12493	6
16	m04503	8
17	m04301	6
26	m01203	8
27	m01214	6
40	m16186	2
41	m12572	2

Ⓒ SADA NÁPRAVY

Ⓓ SATZ AUFHÄNGUNG

Ⓕ KIT DE L'ESSIEU

VZ00016126

Ⓖ AXLE SET

Ⓡ КОМПЛЕКТ ОСИ КОЛЁС

Ⓢ ZESTAW OSI

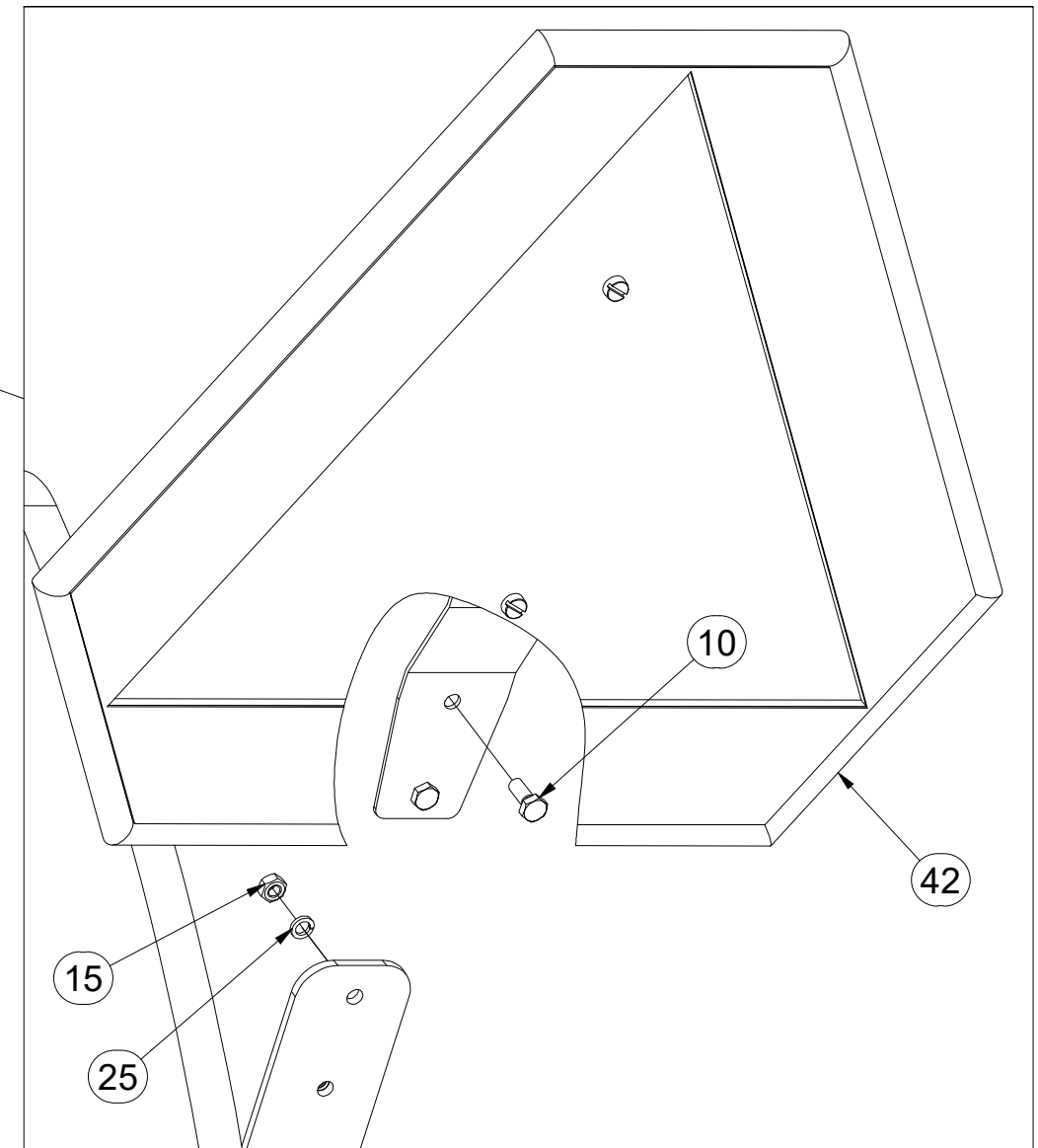
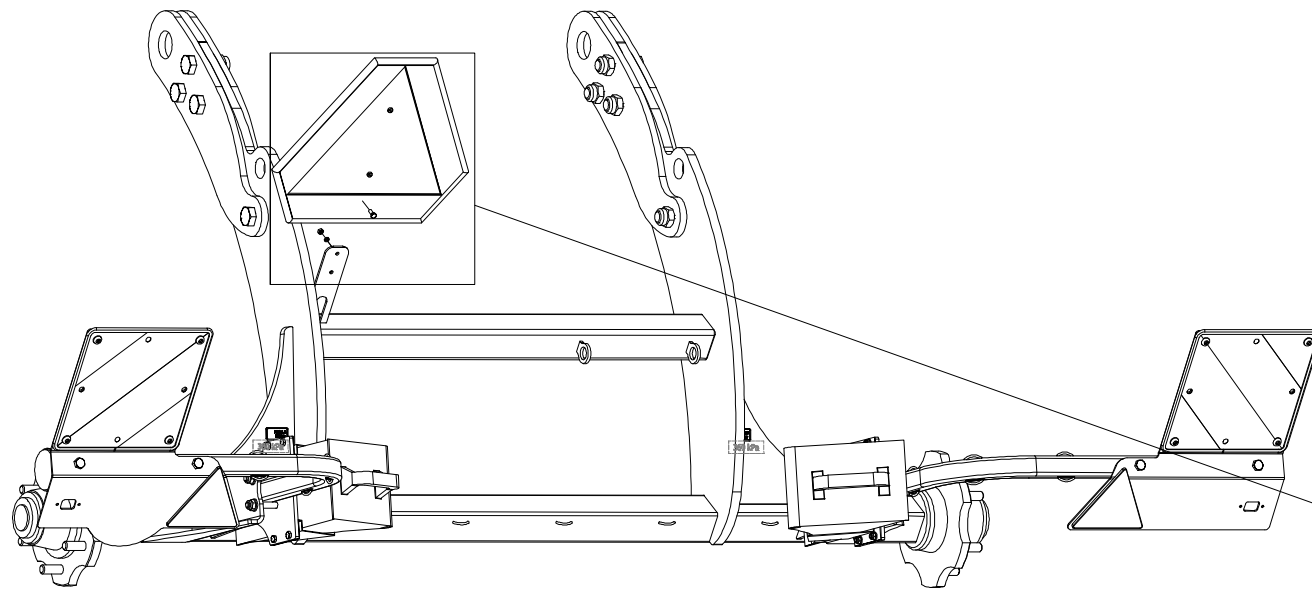

Pos.	Part Number	Pcs.
10	m01073	2
15	m01295	2
25	m01200	2
42	m05371	1

Ⓒ NÁPRAVA

Ⓓ ACHSE

Ⓕ ESSIEU

Ⓖ AXLE

Ⓡ OCB

Ⓟ OS



A70MR600N002

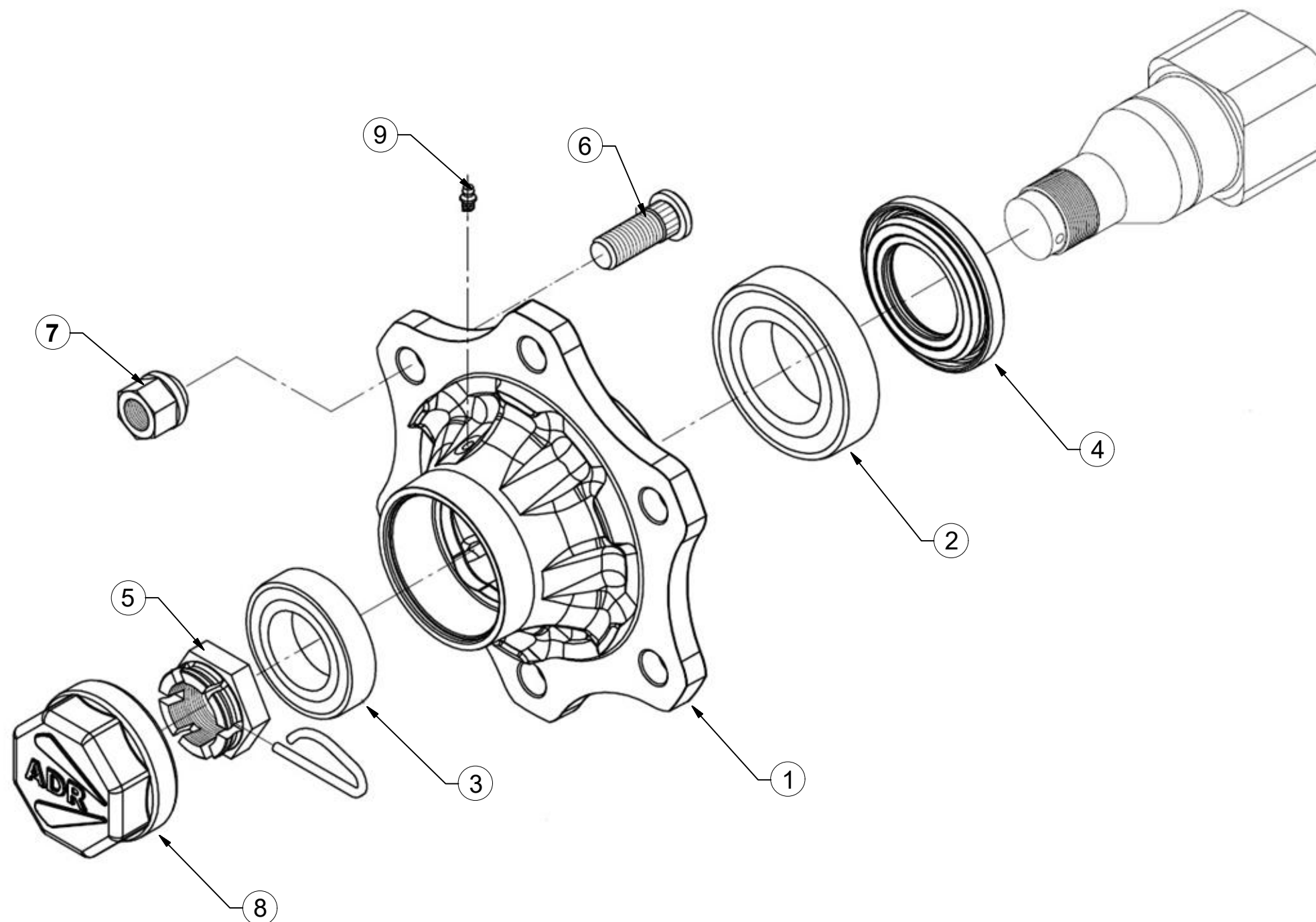

Pos	Part Number	Pcs.
1	m19667	2
2	m08194	2
3	m07152	2
4	m14924	2
5	m08169	2
6	m08148	12
7	m08163	12
8	m19668	2
9	m05698	2

Ⓒ SADA NÁPRAVY

Ⓓ SATZ AUFHÄNGUNG

Ⓕ KIT DE L'ESSIEU

VZ00016131

Ⓖ AXLE SET

Ⓡ КОМПЛЕКТ ОСИ КОЛЁС

Ⓢ ZESTAW OSI



Pos.	Part Number	Pcs.
1	m22332	1
2	m22329	1
3	m19657	12
4	m13554	2

	M18x1,5-265Nm
	360 kPa

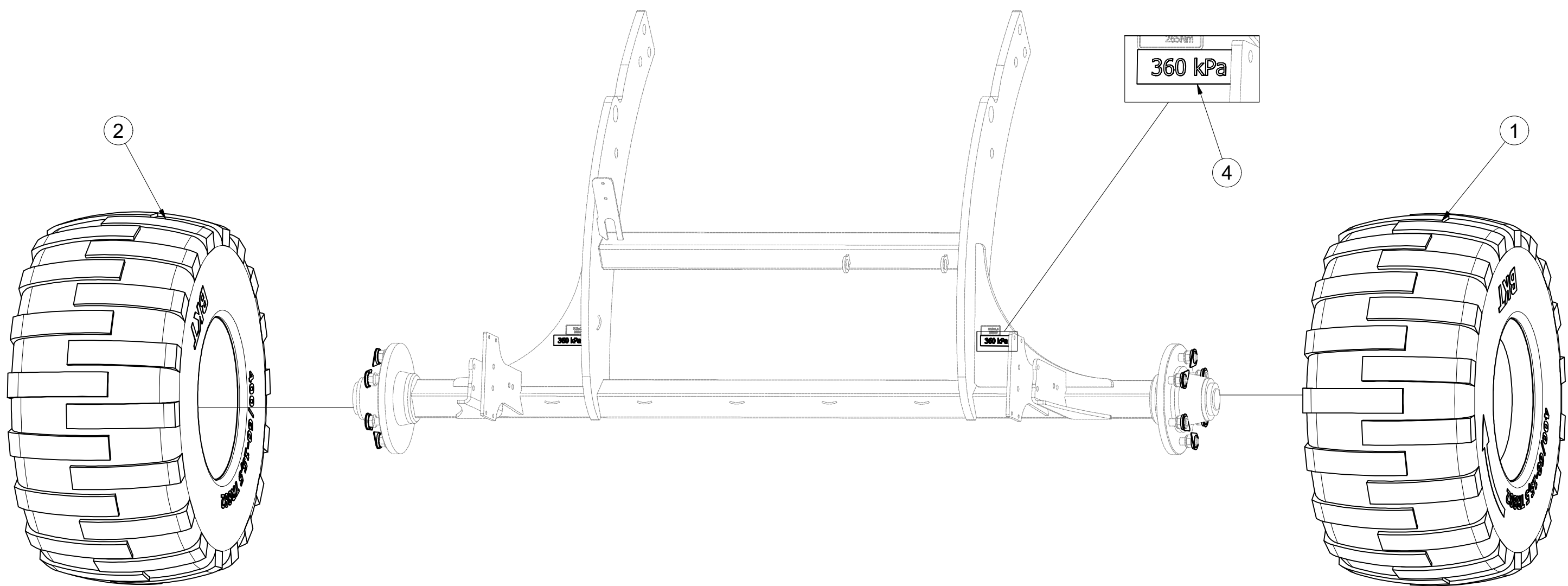
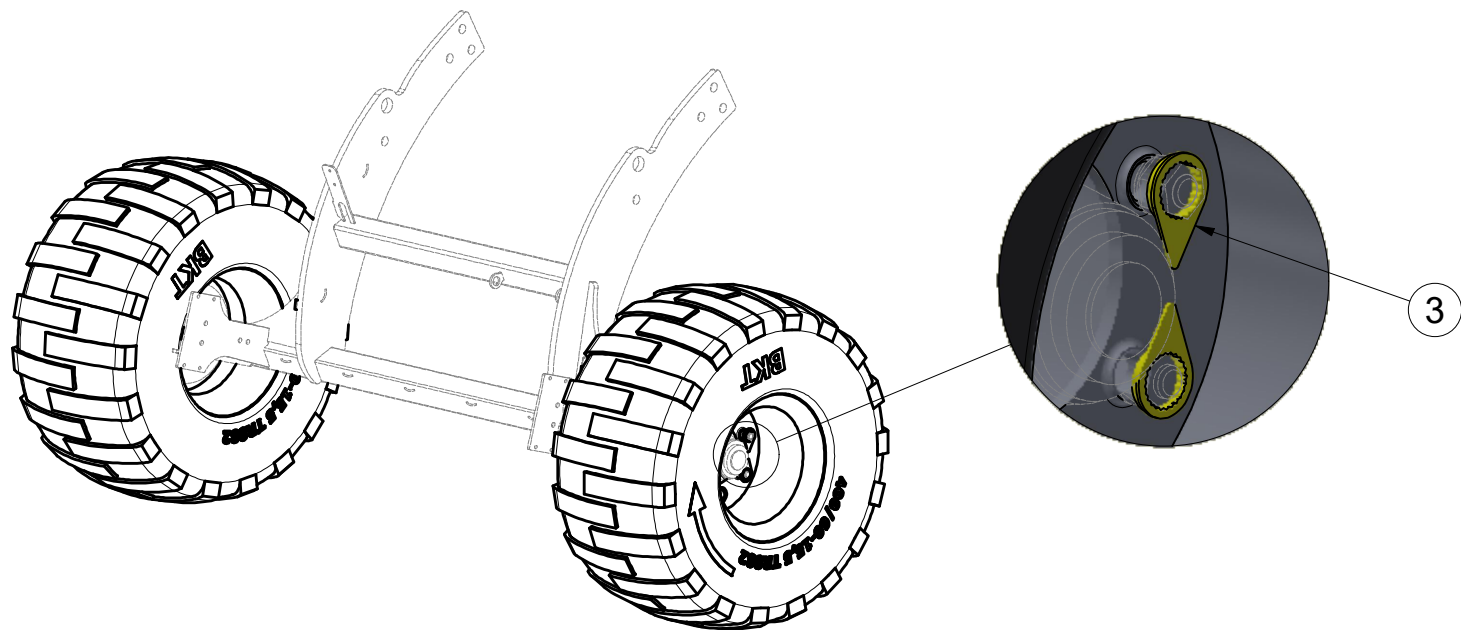

ⒸZ TERČ ZADNÍ LEVÝ

Ⓓ SCHILD, HINTERES, LINKES

Ⓕ CIBLE ARRIÈRE GAUCHE

3012431

ⒼB LEFT REAR DISC

ⒺЩИТОК ЗАДНИЙ ЛЕВЫЙ

ⒽL TARCZA TYLNA LEWA

Farmet

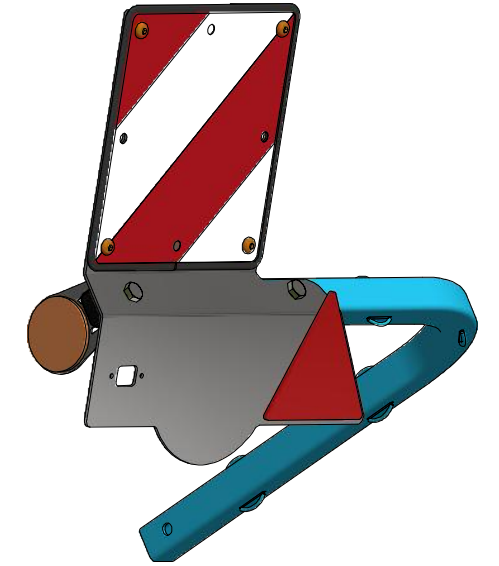
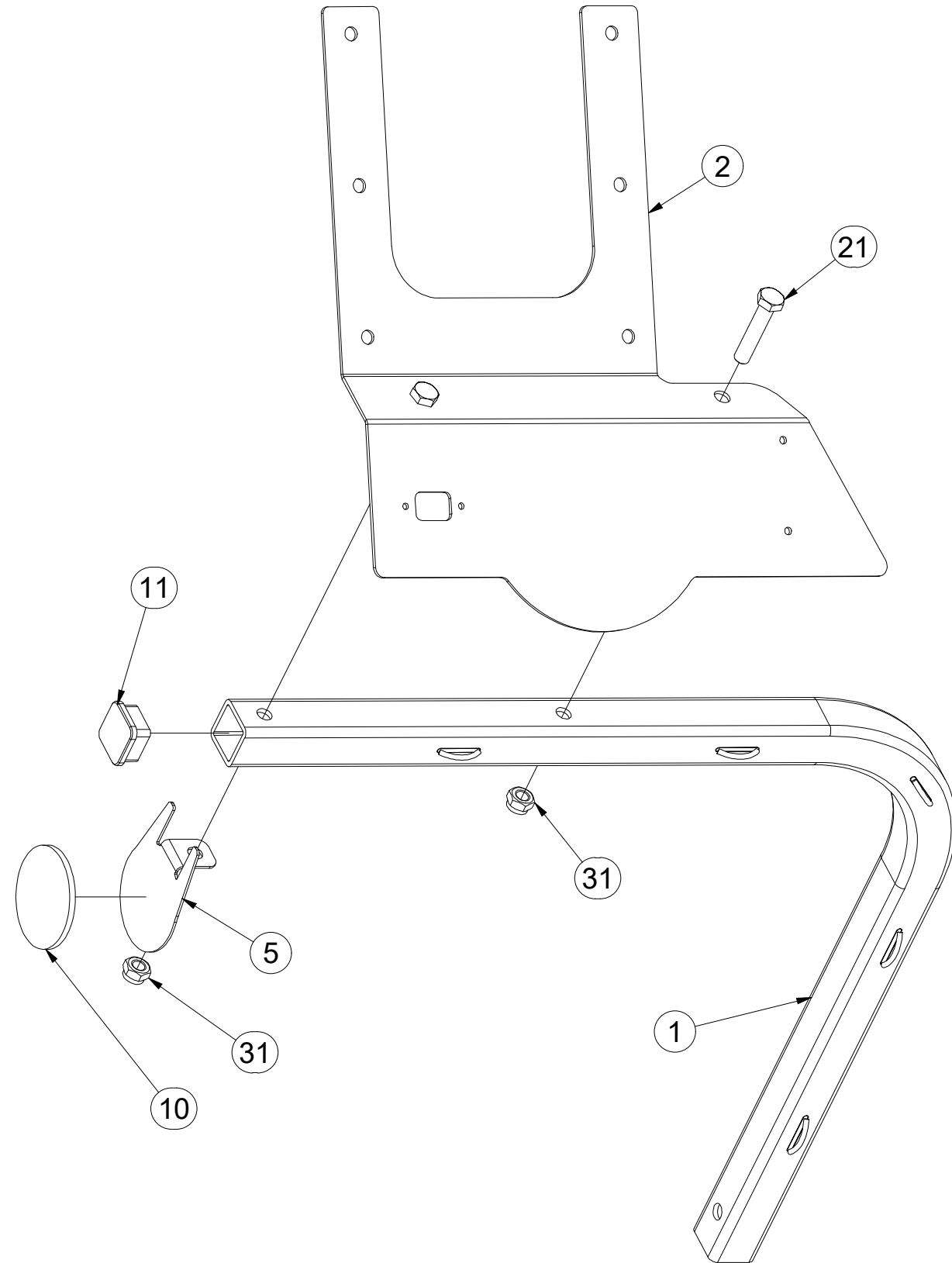

Pos.	Part Number	Pcs.
1	3012433	1
2	3012365	1
5	4024926	1
10	m02579	1
11	m12689	1
21	m01131	2
31	m04301	2

ⒸZ TERČ ZADNÍ LEVÝ

Ⓓ SCHILD, HINTERES, LINKES

Ⓕ CIBLE ARRIÈRE GAUCHE

3012431

ⒼB LEFT REAR DISC

ⒺU ЩИТОК ЗАДНИЙ ЛЕВЫЙ

ⒼL TARCZA TYLNA LEWA

Farmet

Pos.	Part Number	Pcs.
3	m18855	1
4	9005707	1
12	m02497	1
20	m16637	4
30	m03775	4
35	m01209	4

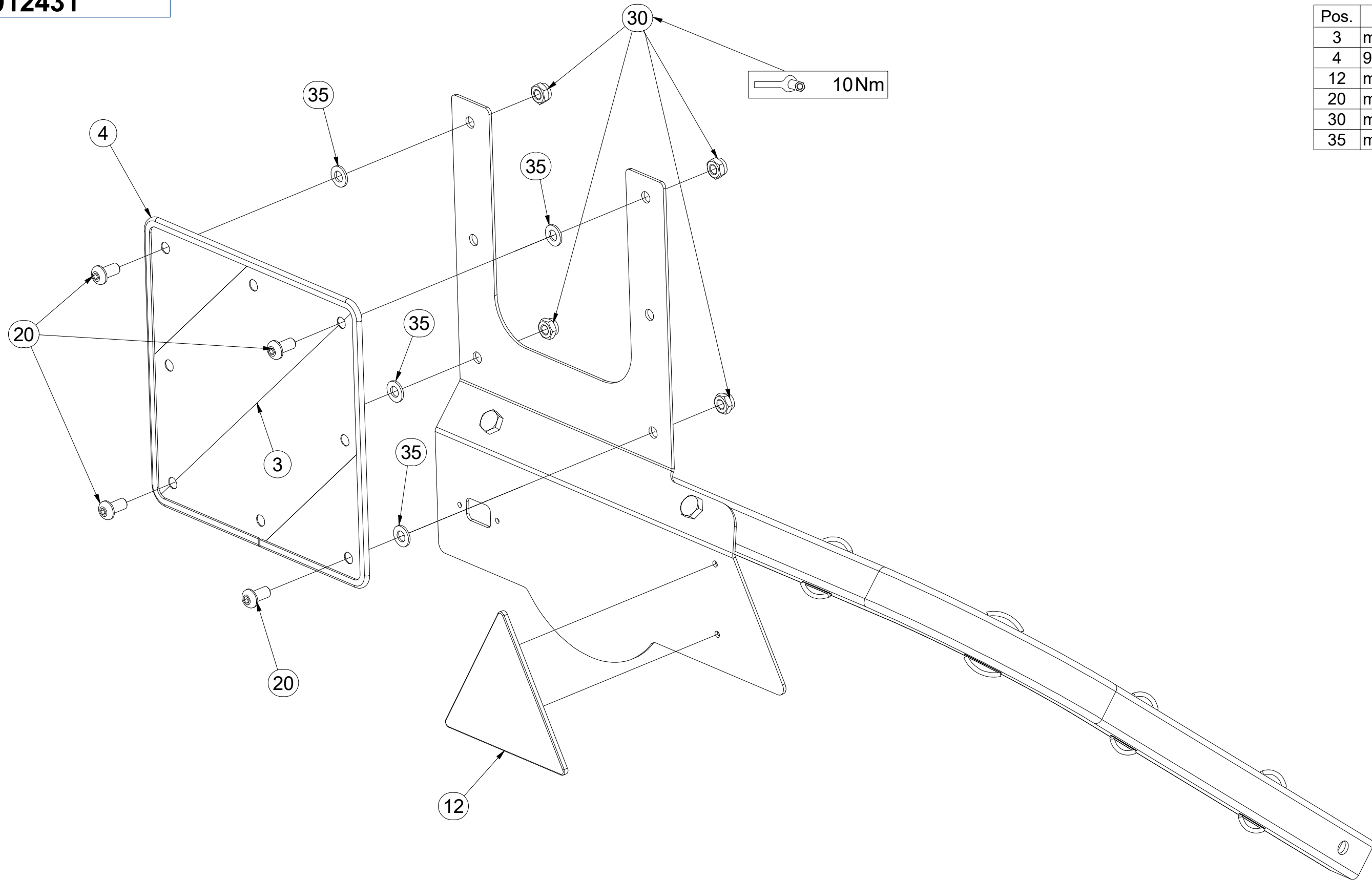

ⒸZ TERČ ZADNÍ PRAVÝ

Ⓓ SCHILD, HINTERES, RECHTES

Ⓕ CIBLE ARRIÈRE DROITE

3012432

ⒼB RIGHT REAR DISC

ⒺЩИТОК ЗАДНИЙ ПРАВЫЙ

ⒽL TARCZA TYLNA PRAWA

Farmet

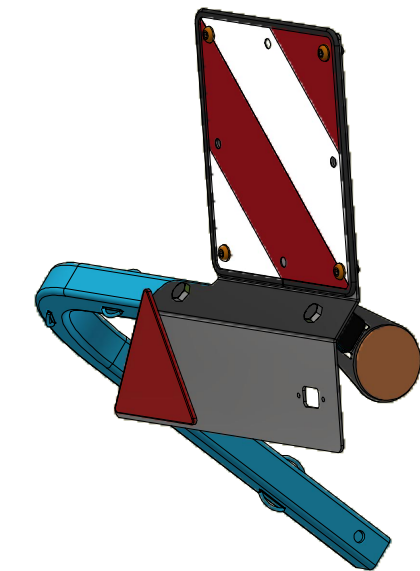
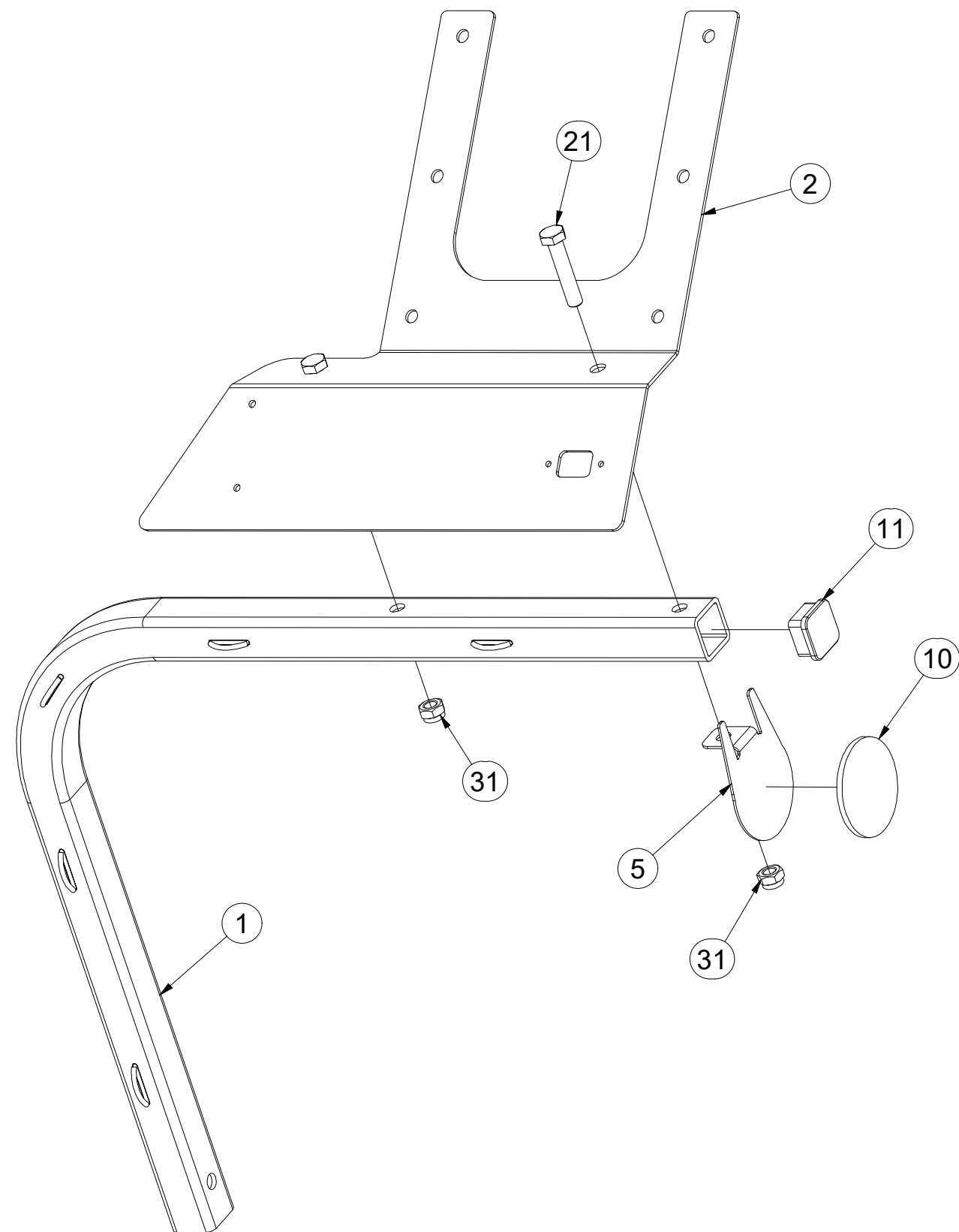

Pos.	Part Number	Pcs.
1	3012433	1
2	3012390	1
5	4024926	1
10	m02579	1
11	m12689	1
21	m01131	2
31	m04301	2

ⒸZ TERČ ZADNÍ PRAVÝ

Ⓓ SCHILD, HINTERES, RECHTES

Ⓕ CIBLE ARRIÈRE DROITE

ⒼB RIGHT REAR DISC

ⒺЩИТОК ЗАДНИЙ ПРАВЫЙ

ⒽL TARCZA TYLNA PRAWA

Farmet

3012432

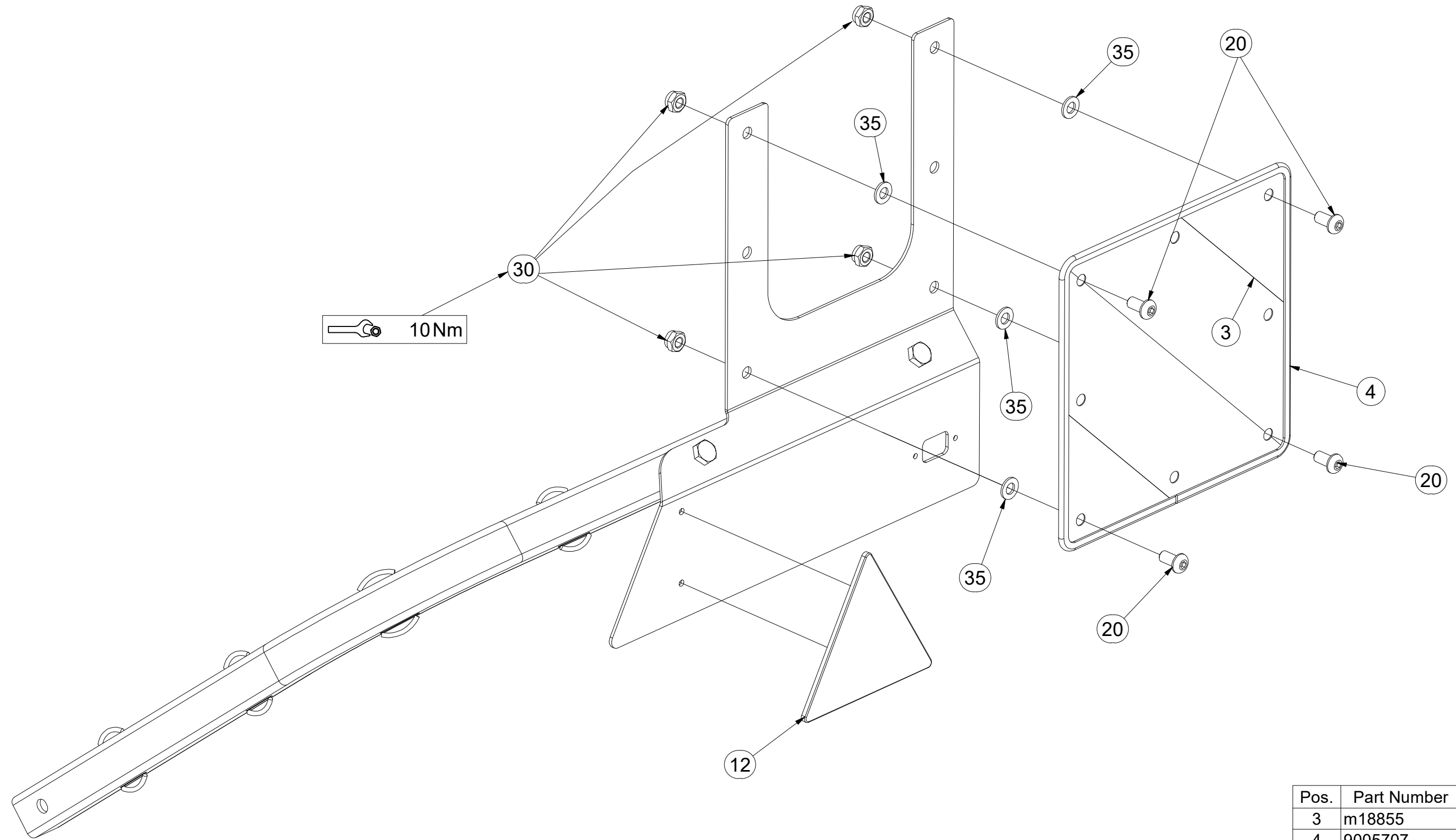

Pos.	Part Number	Pcs.
3	m18855	1
4	9005707	1
12	m02497	1
20	m16637	4
30	m03775	4
35	m01209	4

Ⓒ HYDRAULICKÝ ROZVOD SKLÁPĚNÍ

Ⓓ HYDRAULISCHE VERTEILUNG KLAPPMECHANISMUS

Ⓕ CONDUIT HYDRAULIQUE DU BASCULEMENT

Ⓖ HYDRAULIC FOLDING DISTRIBUTION

Ⓡ ГИДРАВЛИЧЕСКОЕ РАСПРЕДЕЛЕНИЕ СКЛАДЫВАНИЯ

Ⓟ HYDRAULICZNY PRZEWÓD SKŁADANIA

Farmet

VZ00045620

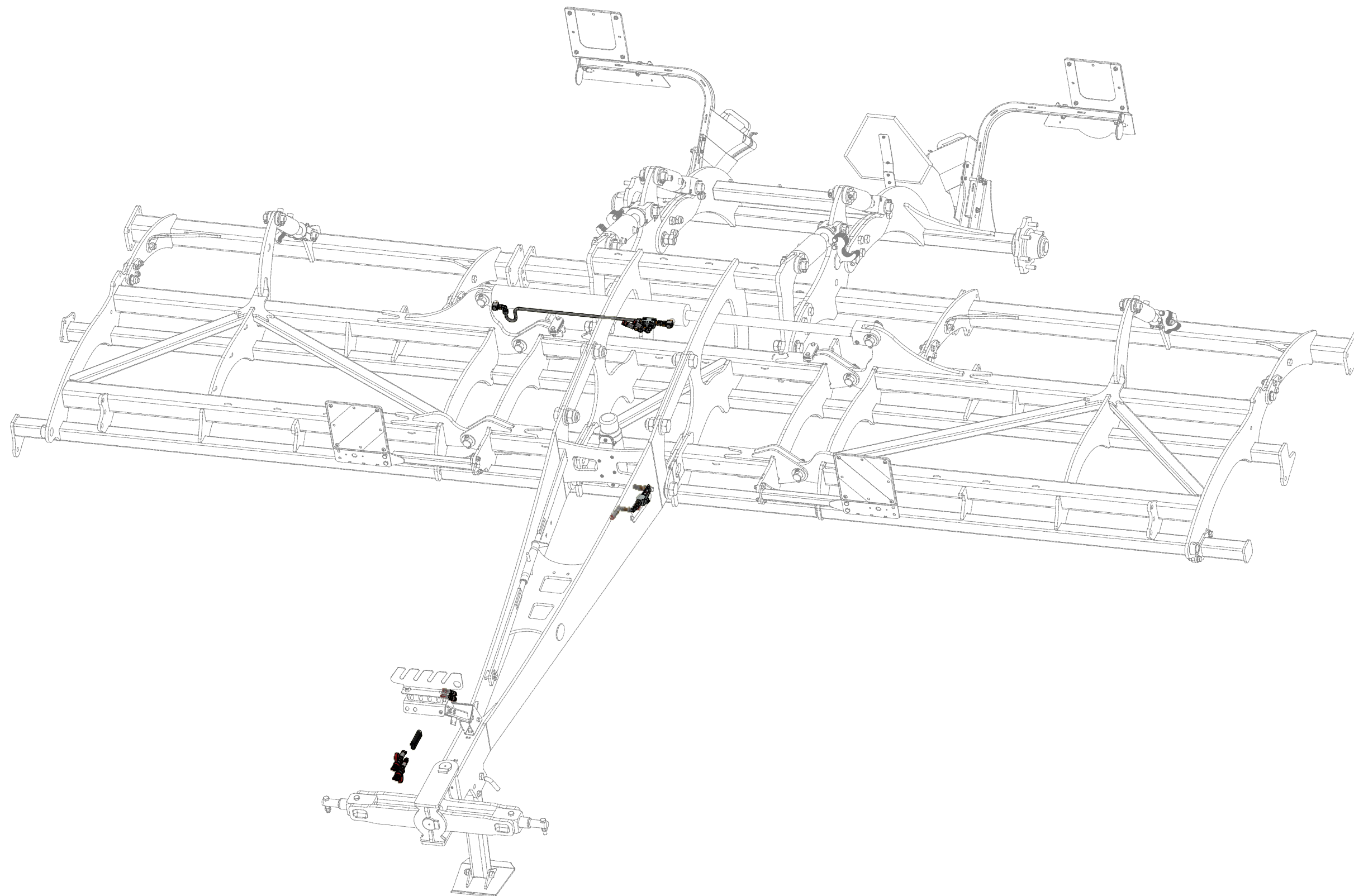

ⒸZ HYDRAULICKÝ ROZVOD SKLÁPĚNÍ

Ⓓ HYDRAULISCHE VERTEILUNG KLAPPMECHANISMUS

Ⓕ CONDUIT HYDRAULIQUE DU BASCULEMENT

ⒸB HYDRAULIC FOLDING DISTRIBUTION

Ⓔ ГИДРАВЛИЧЕСКОЕ РАСПРЕДЕЛЕНИЕ СКЛАДЫВАНИЯ

Ⓗ HYDRAULICZNY PRZEWÓD SKŁADANIA

Farmet

VZ00045620

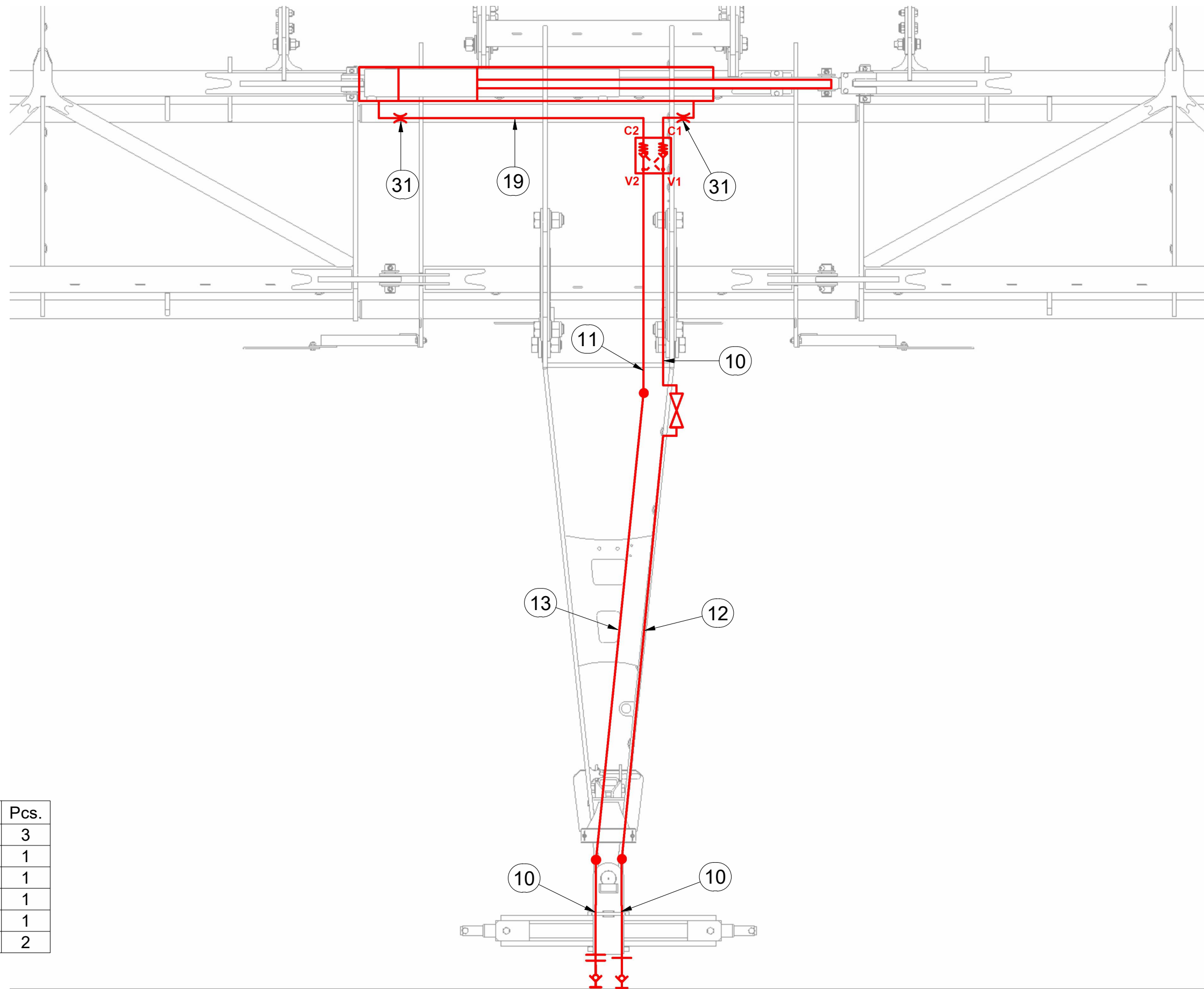

Pos.	Part Number	Pcs.
10	m11696	3
11	m15153	1
12	m16579	1
13	m04181	1
19	m16714	1
31	m10776	2

Ⓒ HYDRAULICKÝ ROZVOD SKLÁPĚNÍ

Ⓓ HYDRAULISCHE VERTEILUNG KLAPPMECHANISMUS

Ⓕ CONDUIT HYDRAULIQUE DU BASCULEMENT

Ⓖ HYDRAULIC FOLDING DISTRIBUTION

Ⓔ ГИДРАВЛИЧЕСКОЕ РАСПРЕДЕЛЕНИЕ СКЛАДЫВАНИЯ

Ⓟ HYDRAULICZNY PRZEWÓD SKŁADANIA



VZ00045620

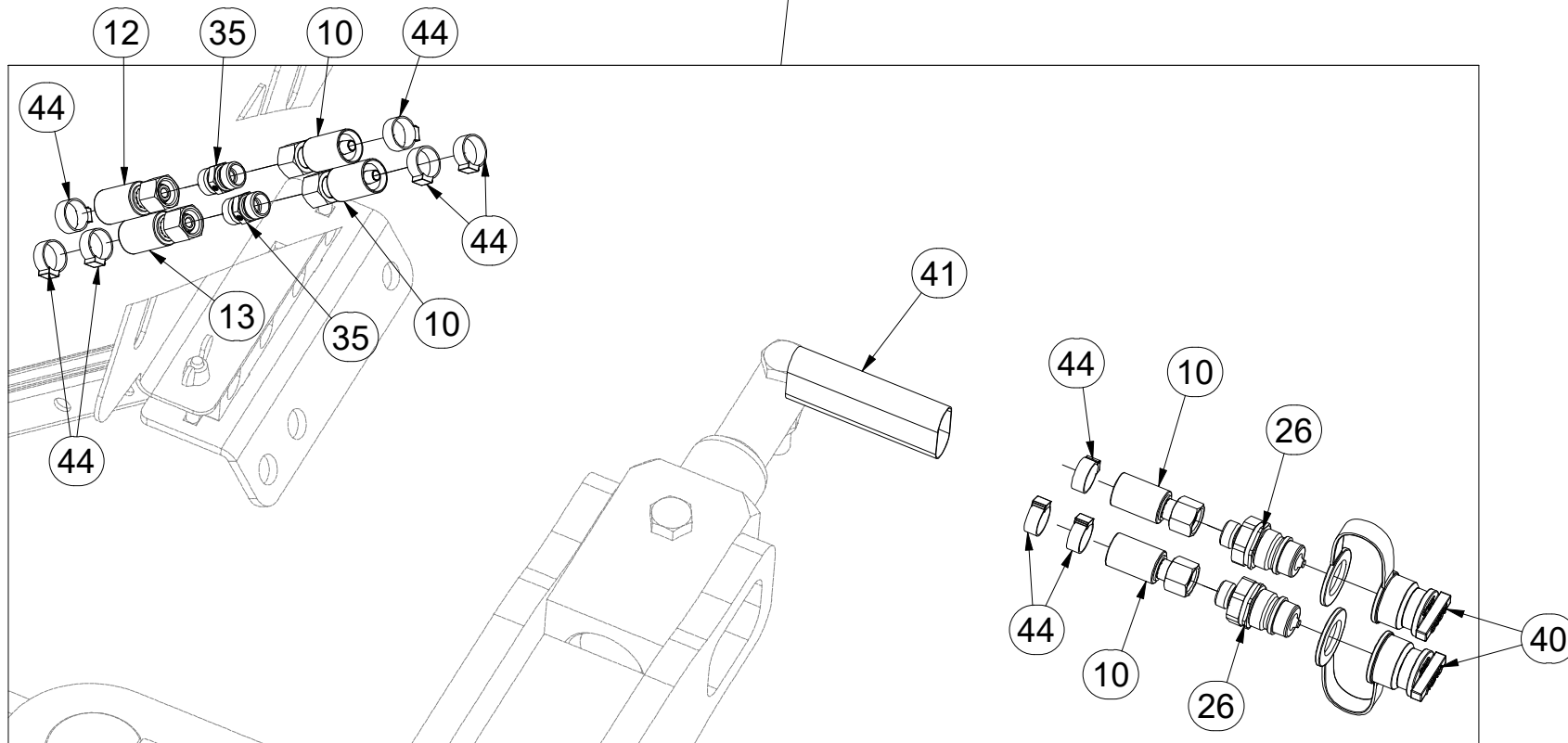
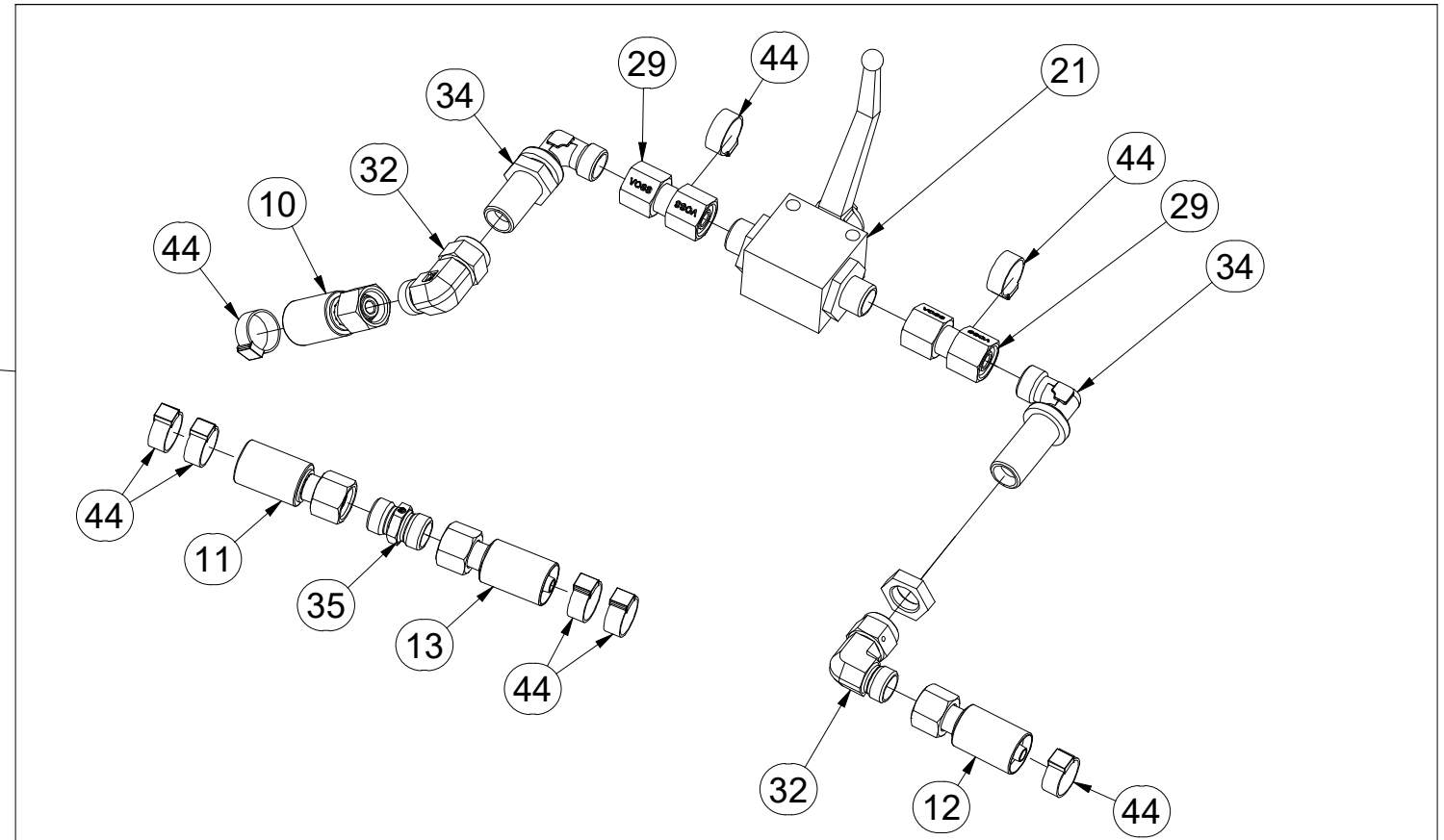
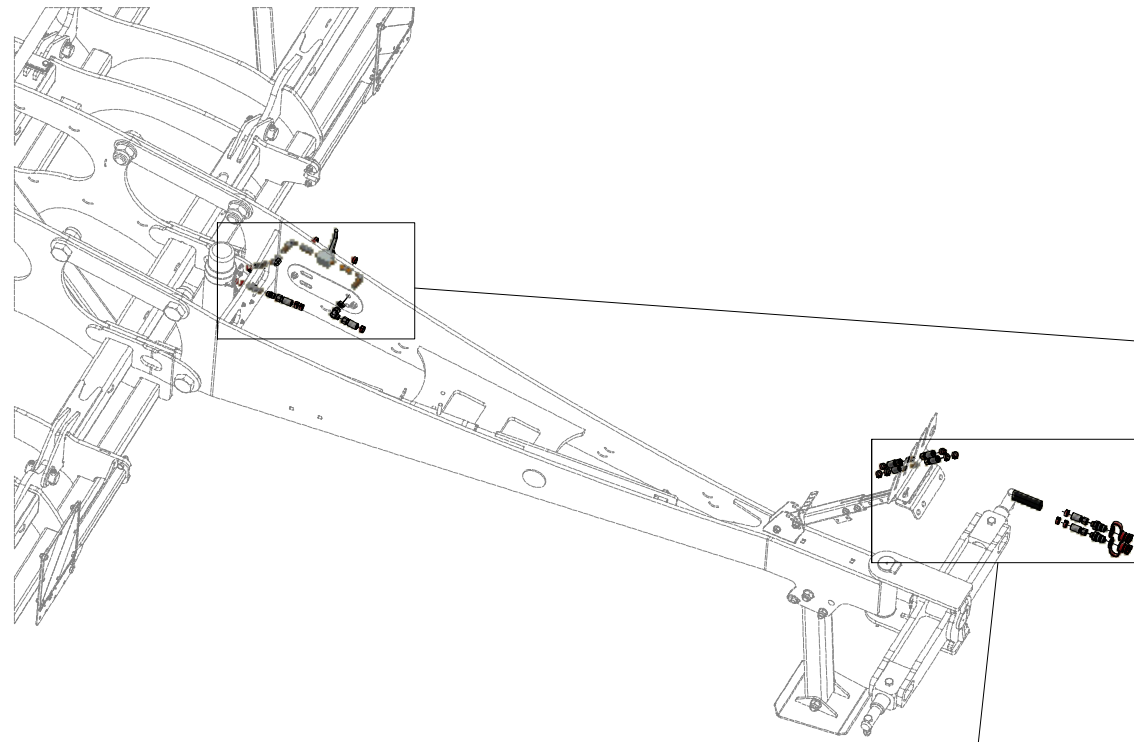

Pos.	Part Number	Pcs.
10	m11696	3
11	m15153	1
12	m16579	1
13	m04181	1
21	m04623	1
26	m03849	2
29	m22305	2
32	m06803	4
34	m08391	2
35	m03213	3
40	m04022	2
41	m11183	1
44	m11294	20

ⒸZ HYDRAULICKÝ ROZVOD SKLÁPĚNÍ

Ⓓ HYDRAULISCHE VERTEILUNG KLAPPMECHANISMUS

Ⓕ CONDUIT HYDRAULIQUE DU BASCULEMENT

ⒸB HYDRAULIC FOLDING DISTRIBUTION

ⒸU ГИДРАВЛИЧЕСКОЕ РАСПРЕДЕЛЕНИЕ СКЛАДЫВАНИЯ

ⒸL HYDRAULICZNY PRZEWÓD SKŁADANIA

Farmet

VZ00045620

Pos.	Part Number	Pcs.
10	m11696	3
11	m15153	1
19	m16714	1
20	m08083	1
25	m20882	2
27	m06528	2
28	m17321	2
30	m22306	1
31	m10776	2
32	m06803	4
33	m07654	1
44	m11294	20

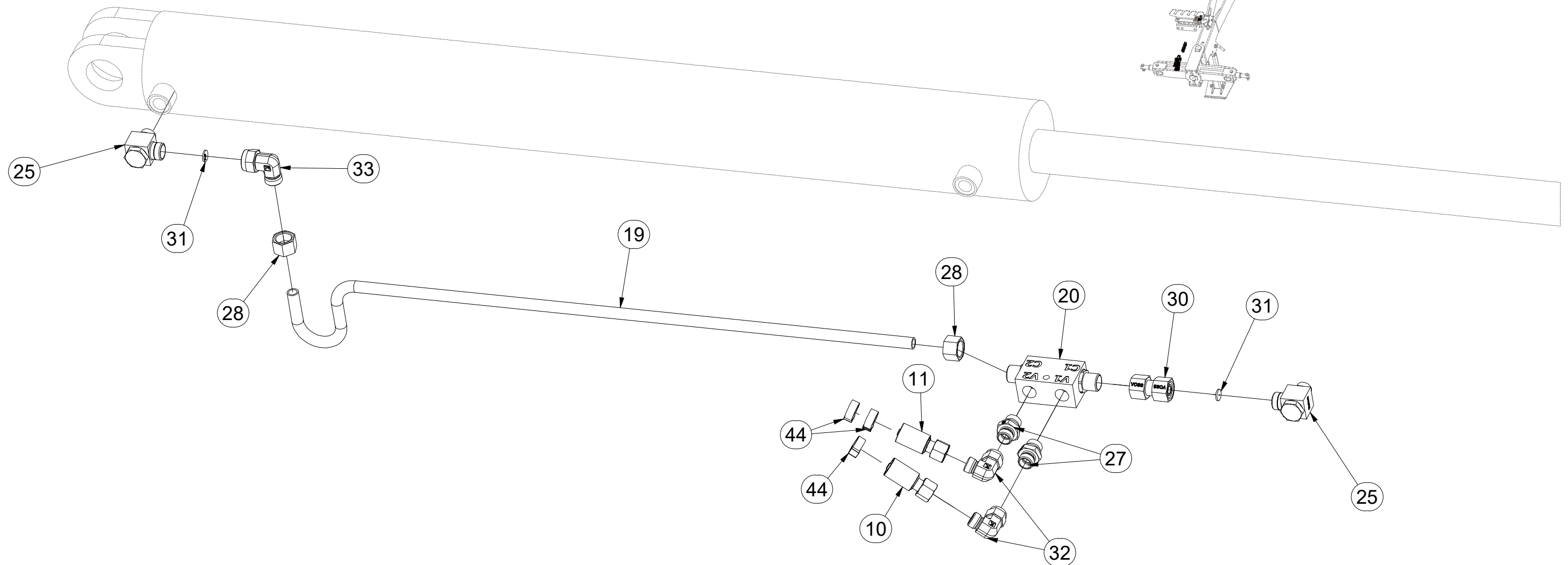
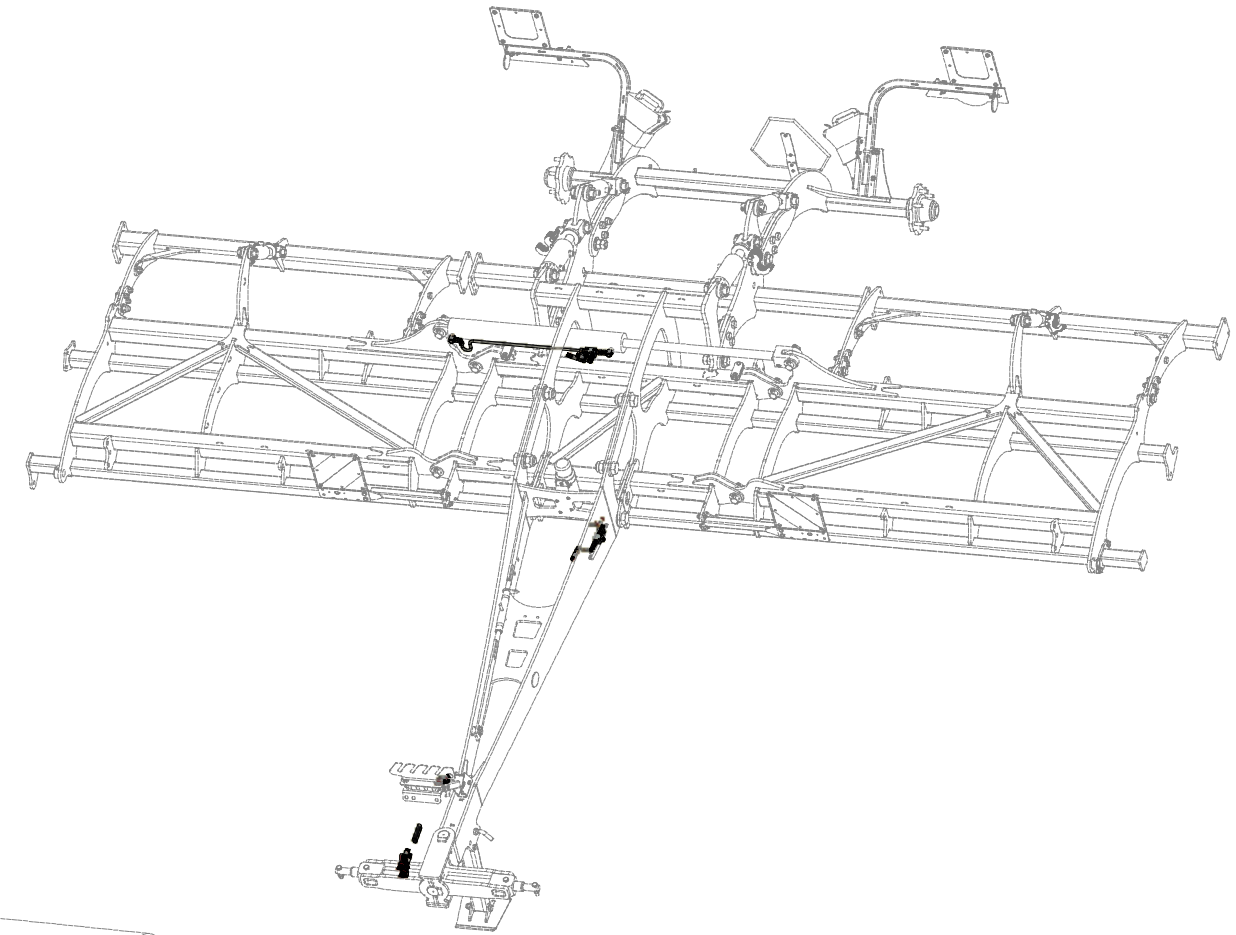

ⒸZ HYDRAULICKÝ ROZVOD - ZAHLUBOVÁNÍ

Ⓓ HYDRAULISCHE VERTEILUNG - EINSENKUNG

Ⓕ CONDUIT HYDRAULIQUE - L'ENFONCEMENT

ⒸB HYDRAULIC DISTRIBUTION - RECESSING

ⒸU ГИДРАВЛИЧЕСКОЕ РАСПРЕДЕЛЕНИЕ - ЗАГЛУБЛЕНИЕ

ⒸL HYDRAULICZNY PRZEWÓD - ZAGŁĘBIENIA

Farmet

VZ00046451

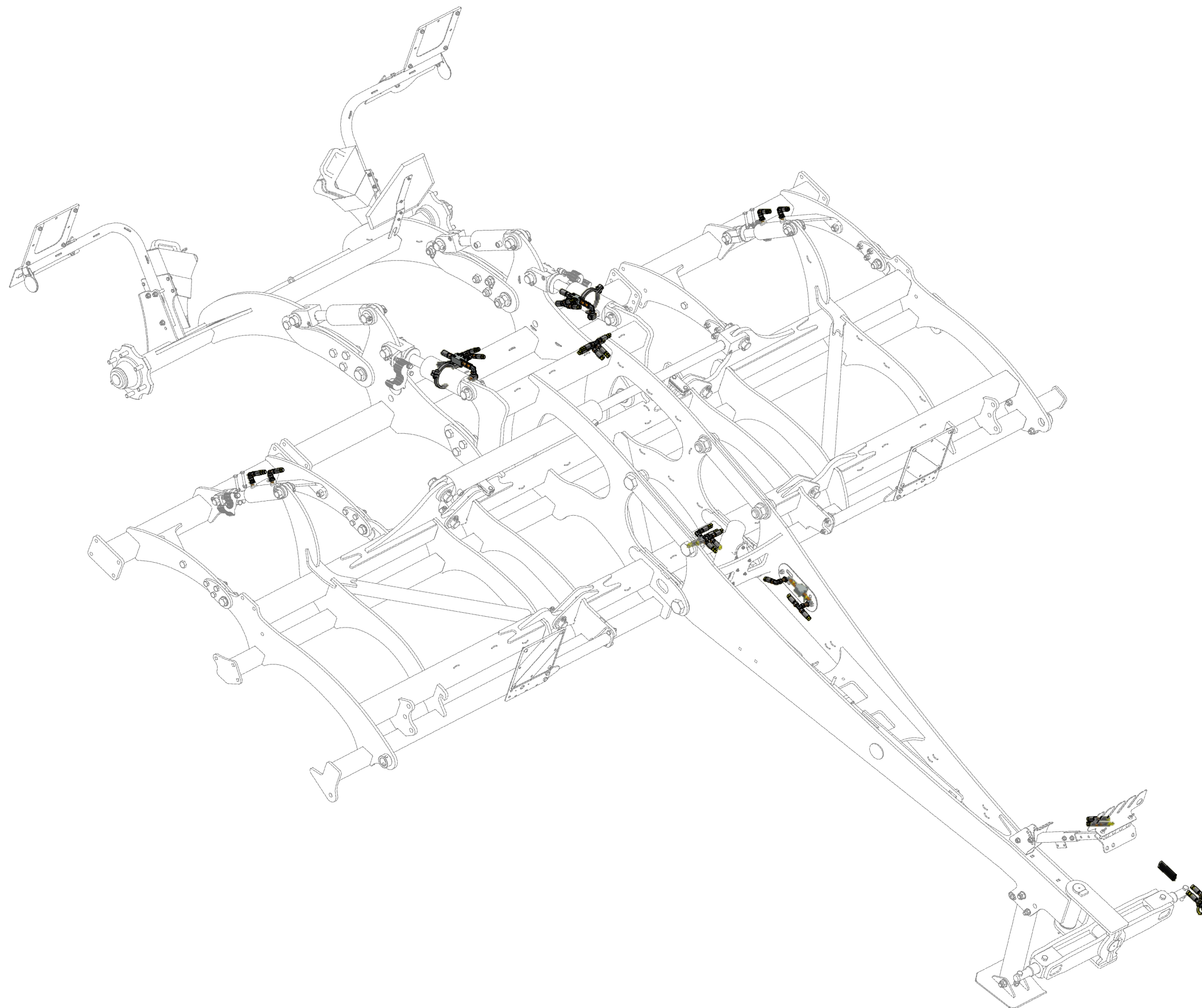

ⒸZ HYDRAULICKÝ ROZVOD - ZAHLUBOVÁNÍ

Ⓓ HYDRAULISCHE VERTEILUNG - EINSENKUNG

Ⓕ CONDUIT HYDRAULIQUE - L'ENFONCEMENT

ⒸB HYDRAULIC DISTRIBUTION - RECESSING

Ⓔ ГИДРАВЛИЧЕСКОЕ РАСПРЕДЕЛЕНИЕ - ЗАГЛУБЛЕНИЕ

ⒼL HYDRAULICZNY PRZEWÓD - ZAGŁĘBIENIA



VZ00046451

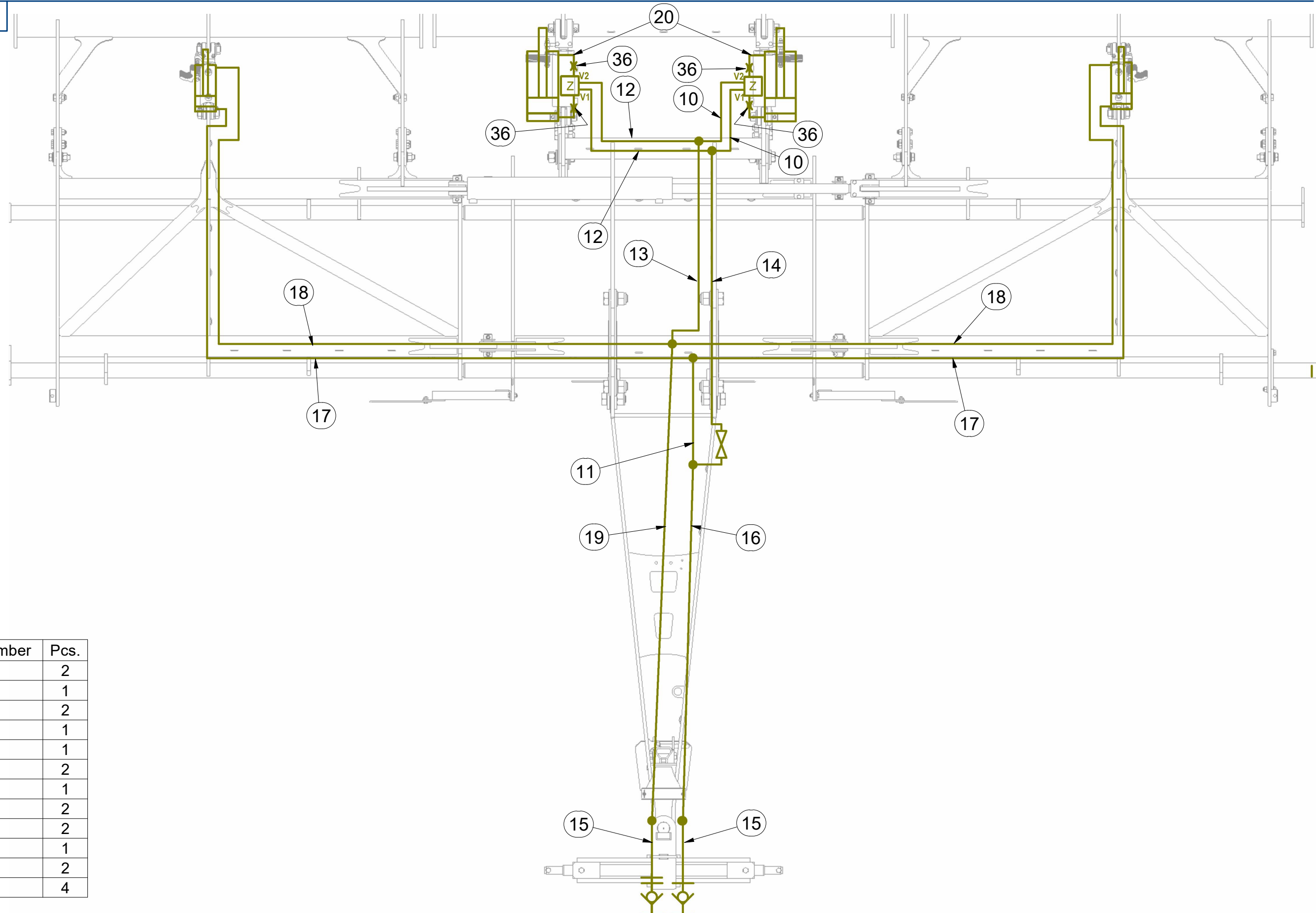

Pos.	Part Number	Pcs.
10	m04827	2
11	m07645	1
12	m16761	2
13	m07360	1
14	m07648	1
15	m11696	2
16	m16579	1
17	m05763	2
18	m08526	2
19	m17445	1
20	m03845	2
36	m10762	4

ⒸZ HYDRAULICKÝ ROZVOD - ZAHLUBOVÁNÍ

Ⓓ HYDRAULISCHE VERTEILUNG - EINSENKUNG

Ⓕ CONDUIT HYDRAULIQUE - L'ENFONCEMENT

ⒸB HYDRAULIC DISTRIBUTION - RECESSING

ⒸU ГИДРАВЛИЧЕСКОЕ РАСПРЕДЕЛЕНИЕ - ЗАГЛУБЛЕНИЕ

ⒸL HYDRAULICZNY PRZEWÓD - ZAGŁĘBIENIA



VZ00046451

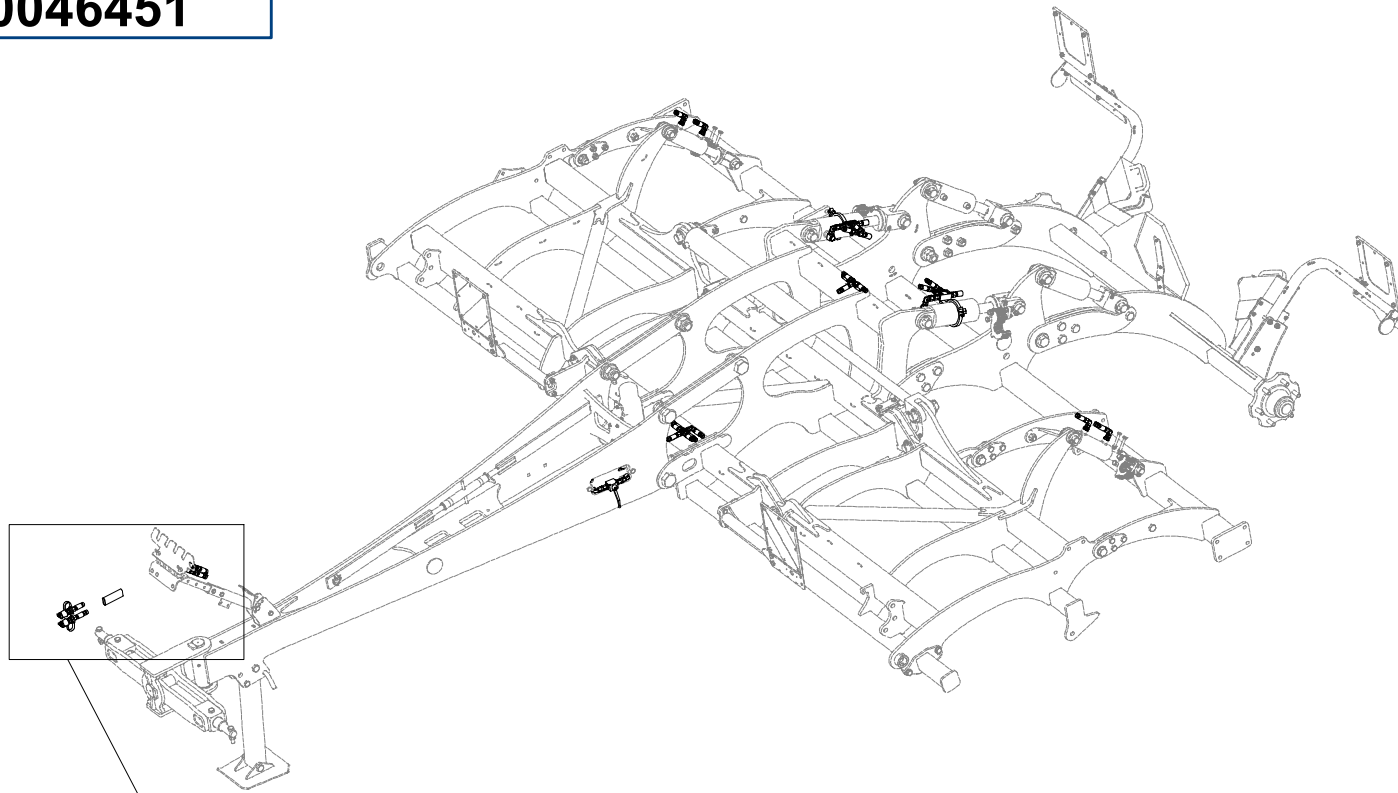

Pos.	Part Number	Pcs.
15	m11696	2
16	m16579	1
19	m17445	1
31	m03849	2
41	m03213	2
50	m04023	2
51	m11183	1
54	m11289	46

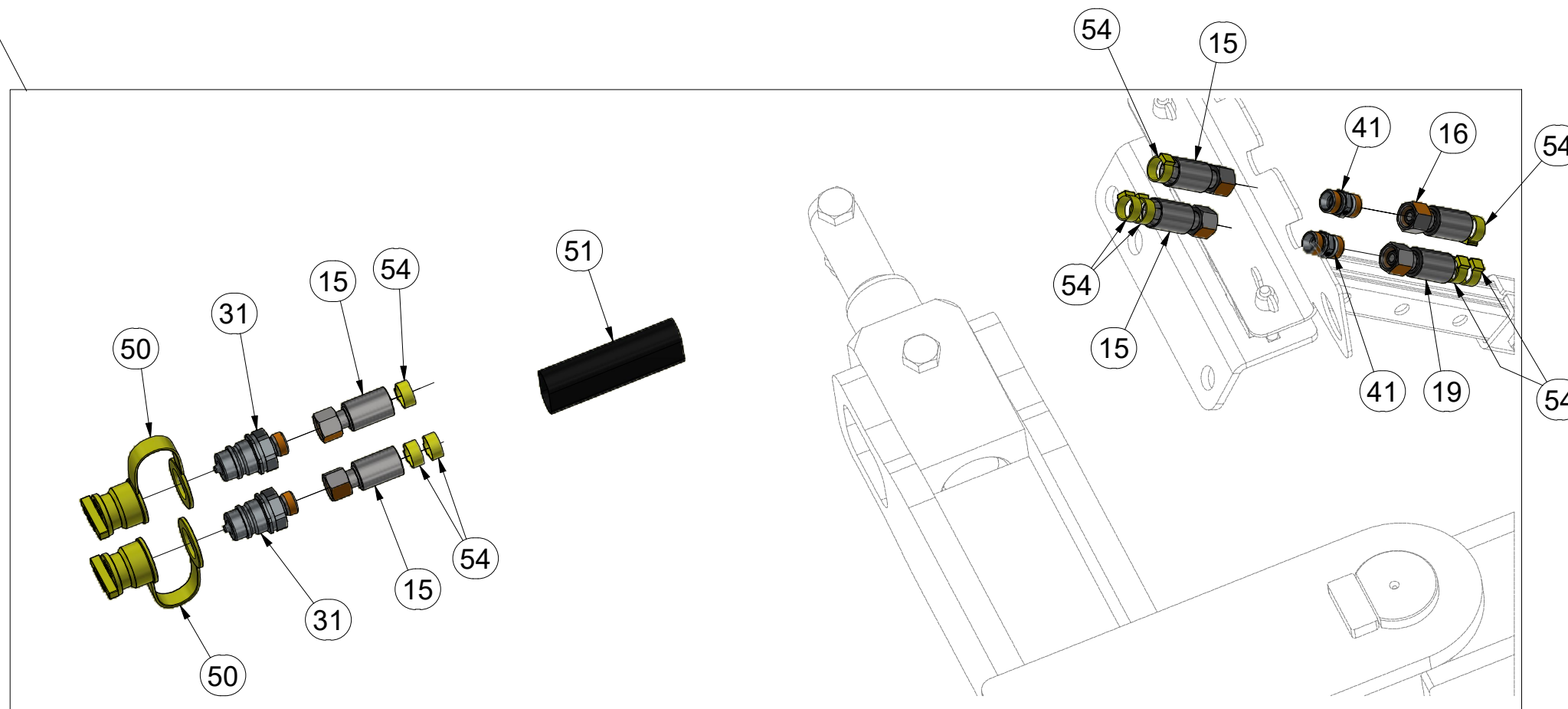

ⒸZ HYDRAULICKÝ ROZVOD - ZAHLUBOVÁNÍ

Ⓓ HYDRAULISCHE VERTEILUNG - EINSENKUNG

Ⓕ CONDUIT HYDRAULIQUE - L'ENFONCEMENT

ⒸB HYDRAULIC DISTRIBUTION - RECESSING

ⒸR ГИДРАВЛИЧЕСКОЕ РАСПРЕДЕЛЕНИЕ - ЗАГЛУБЛЕНИЕ

ⒸL HYDRAULICZNY PRZEWÓD - ZAGŁĘBIENIA



VZ00046451

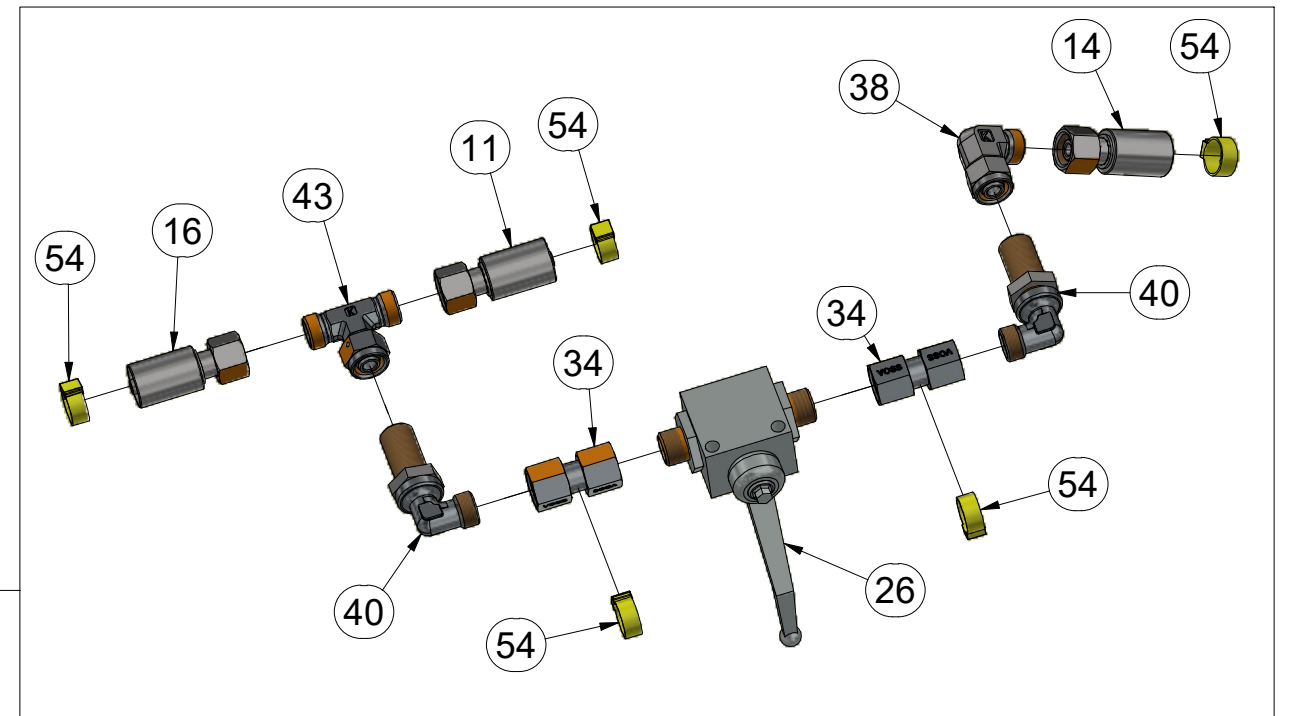
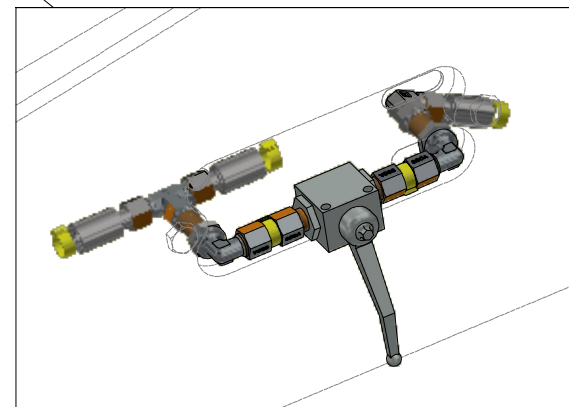
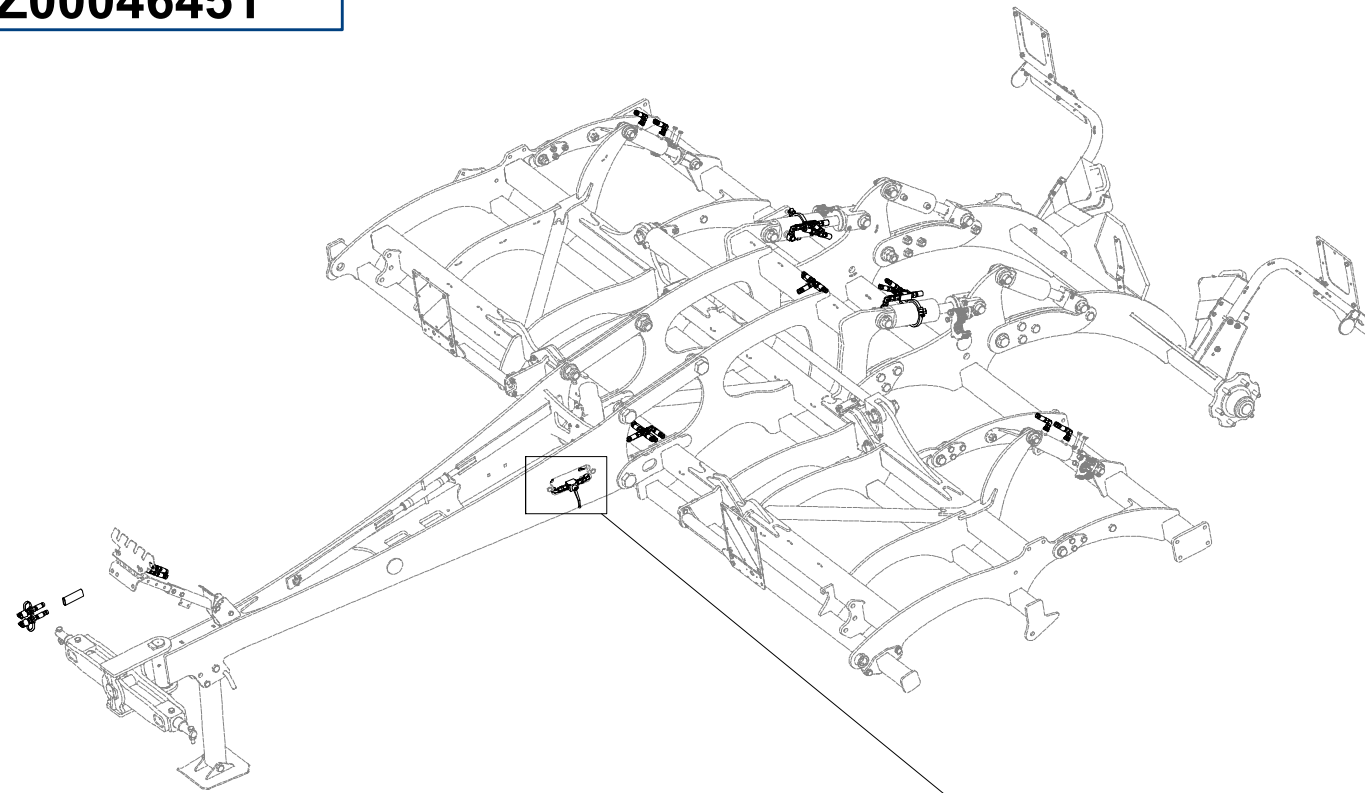

Pos.	Part Number	Pcs.
11	m07645	1
14	m07648	1
16	m16579	1
26	m04623	1
34	m22305	2
38	m06803	10
40	m08391	2
43	m07567	1
54	m11289	46

Ⓒ HYDRAULICKÝ ROZVOD - ZAHLUBOVÁNÍ

Ⓓ HYDRAULISCHE VERTEILUNG - EINSENKUNG

Ⓕ CONDUIT HYDRAULIQUE - L'ENFONCEMENT

Ⓒ HYDRAULIC DISTRIBUTION - RECESSING

Ⓓ ГИДРАВЛИЧЕСКОЕ РАСПРЕДЕЛЕНИЕ - ЗАГЛУБЛЕНИЕ

Ⓕ HYDRAULICZNY PRZEWÓD - ZAGŁĘBIENIA



VZ00046451

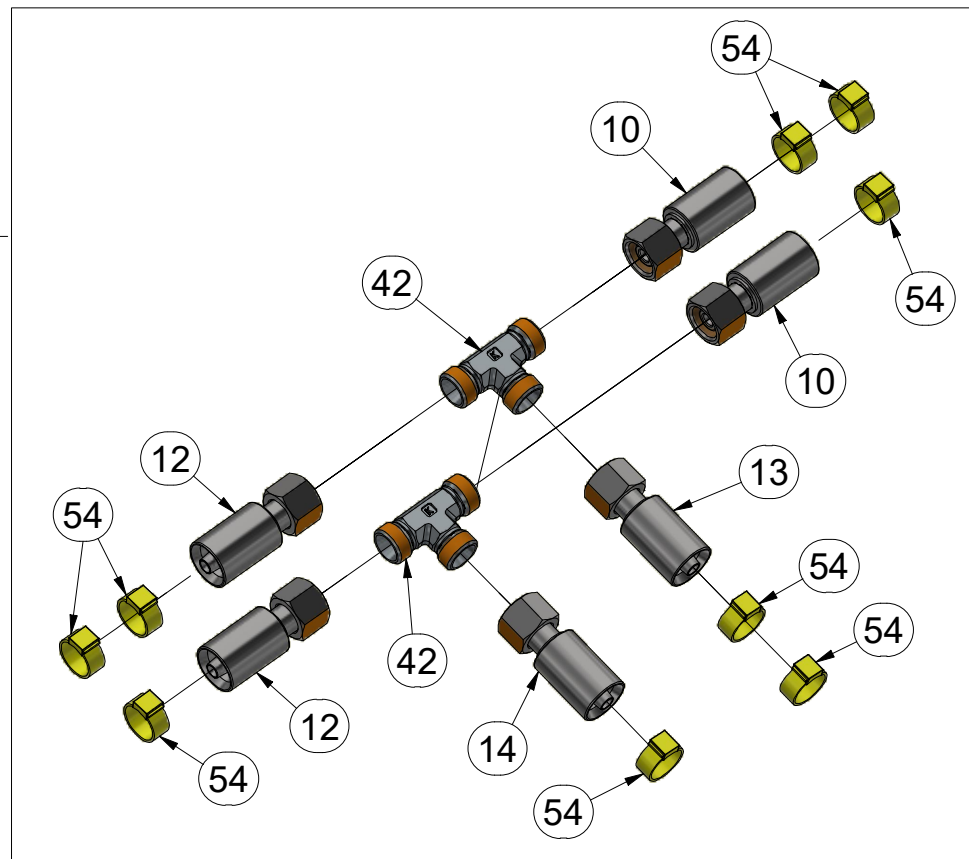
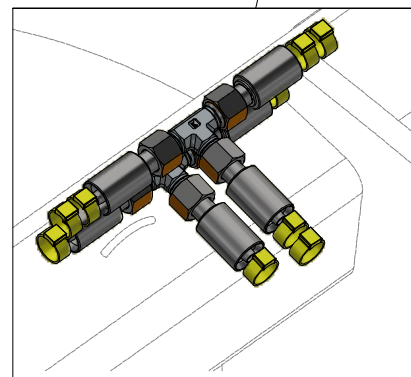
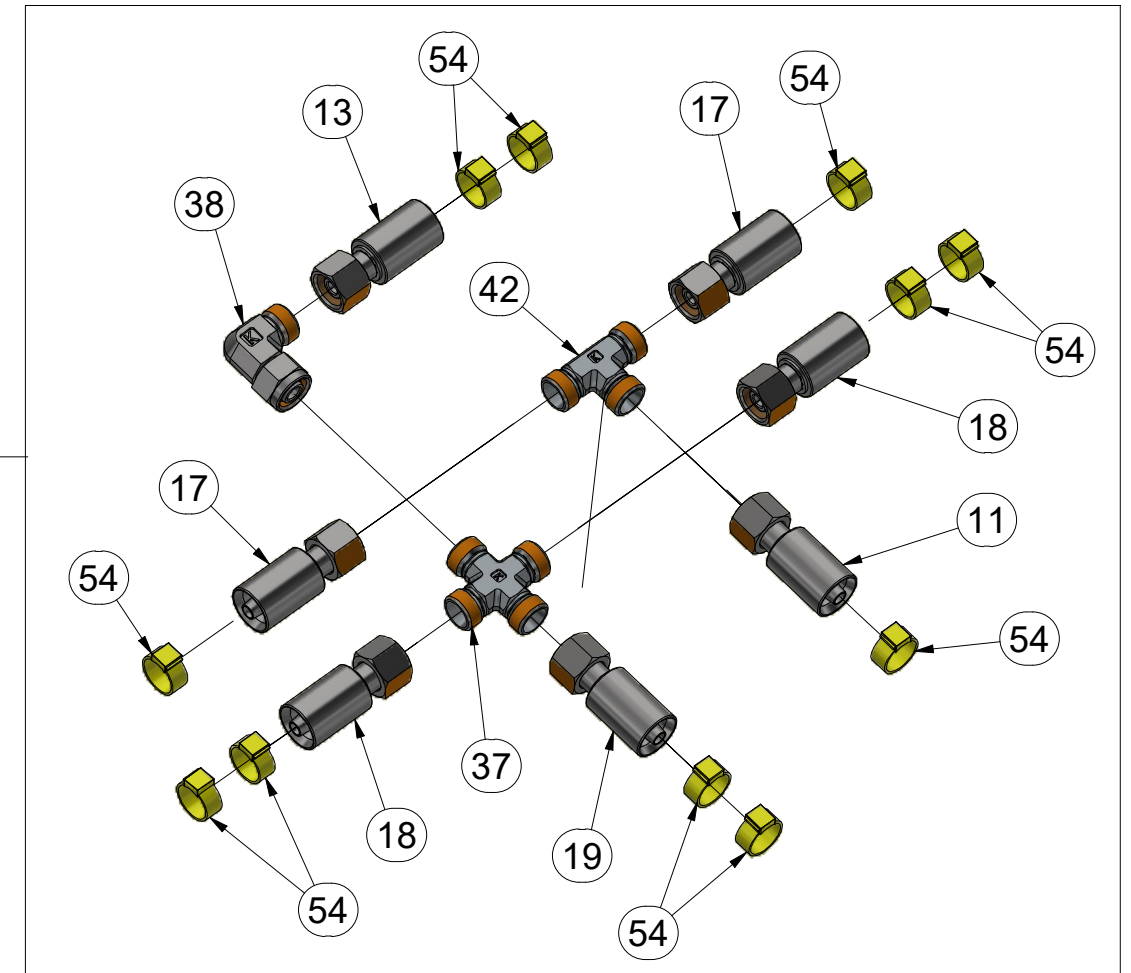
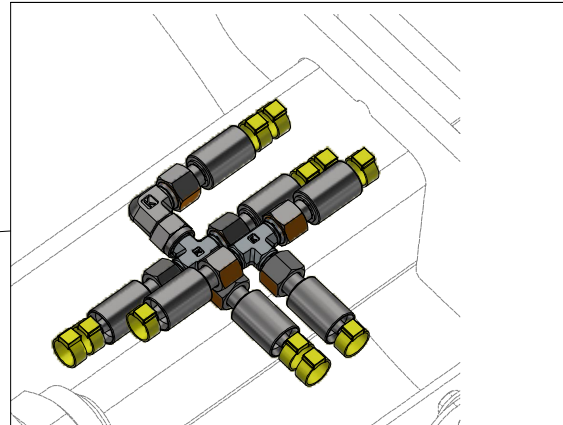
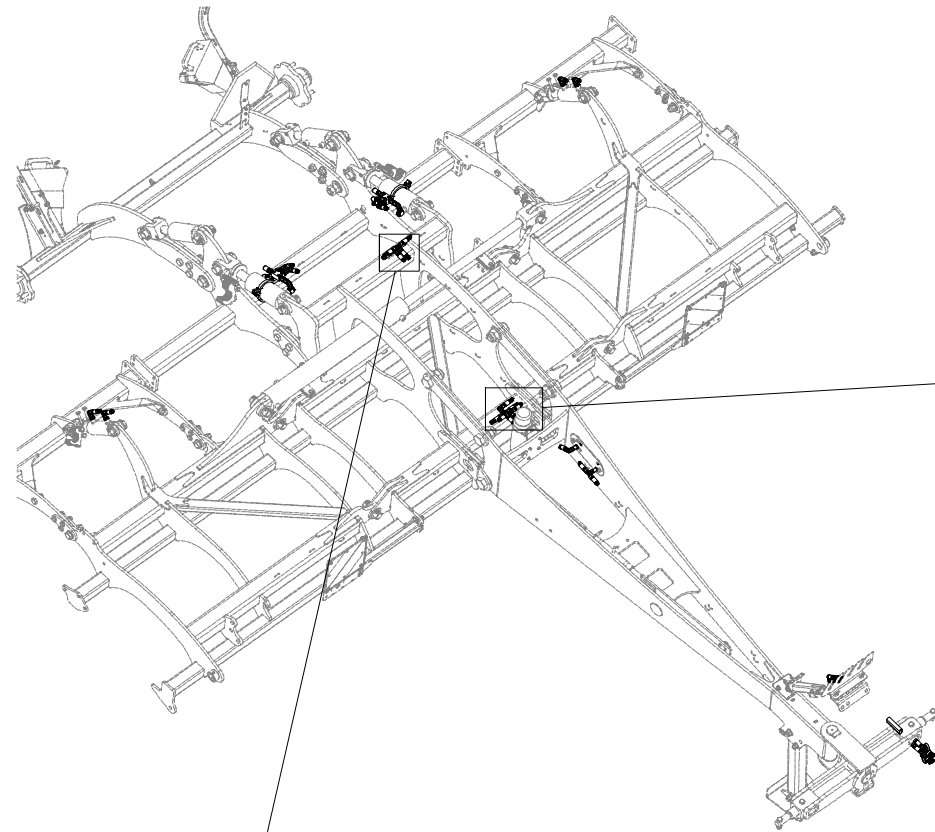

Pos.	Part Number	Pcs.
10	m04827	2
11	m07645	1
12	m16761	2
13	m07360	1
14	m07648	1
17	m05763	2
18	m08526	2
19	m17445	1
37	m08328	1
38	m06803	10
42	m03889	3
54	m11289	46

ⒸZ HYDRAULICKÝ ROZVOD - ZAHLUBOVÁNÍ

Ⓓ HYDRAULISCHE VERTEILUNG - EINSENKUNG

Ⓕ CONDUIT HYDRAULIQUE - L'ENFONCEMENT

ⒸB HYDRAULIC DISTRIBUTION - RECESSING

ⒸU ГИДРАВЛИЧЕСКОЕ РАСПРЕДЕЛЕНИЕ - ЗАГЛУБЛЕНИЕ

ⒸL HYDRAULICZNY PRZEWÓD - ZAGŁĘBIENIA



VZ00046451

Pos.	Part Number	Pcs.
17	m05763	2
18	m08526	2
32	m07906	4
38	m06803	10
54	m11289	46

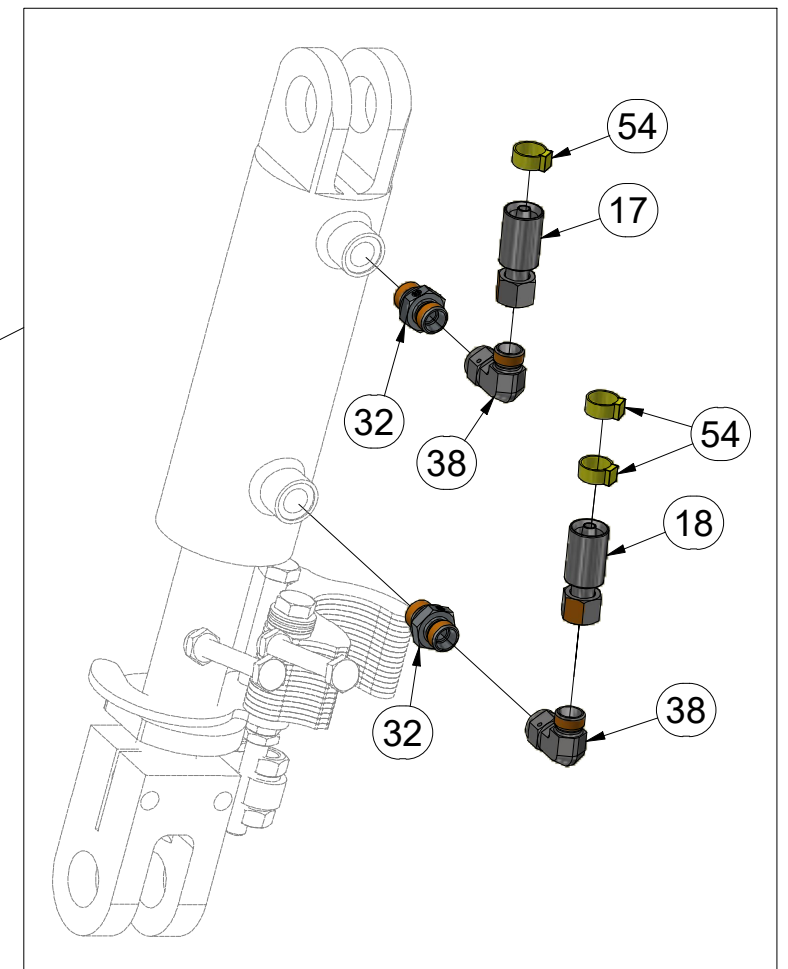
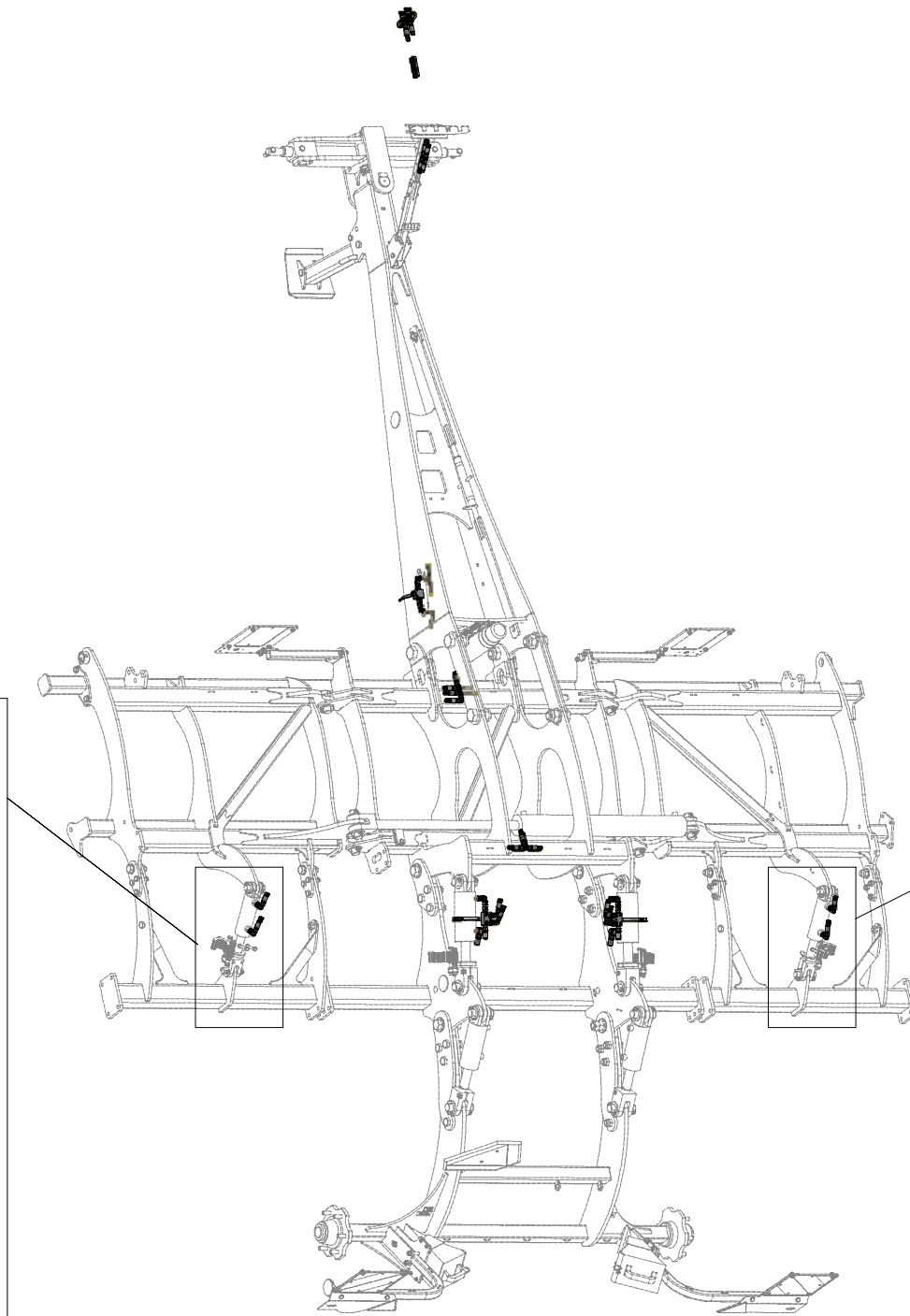
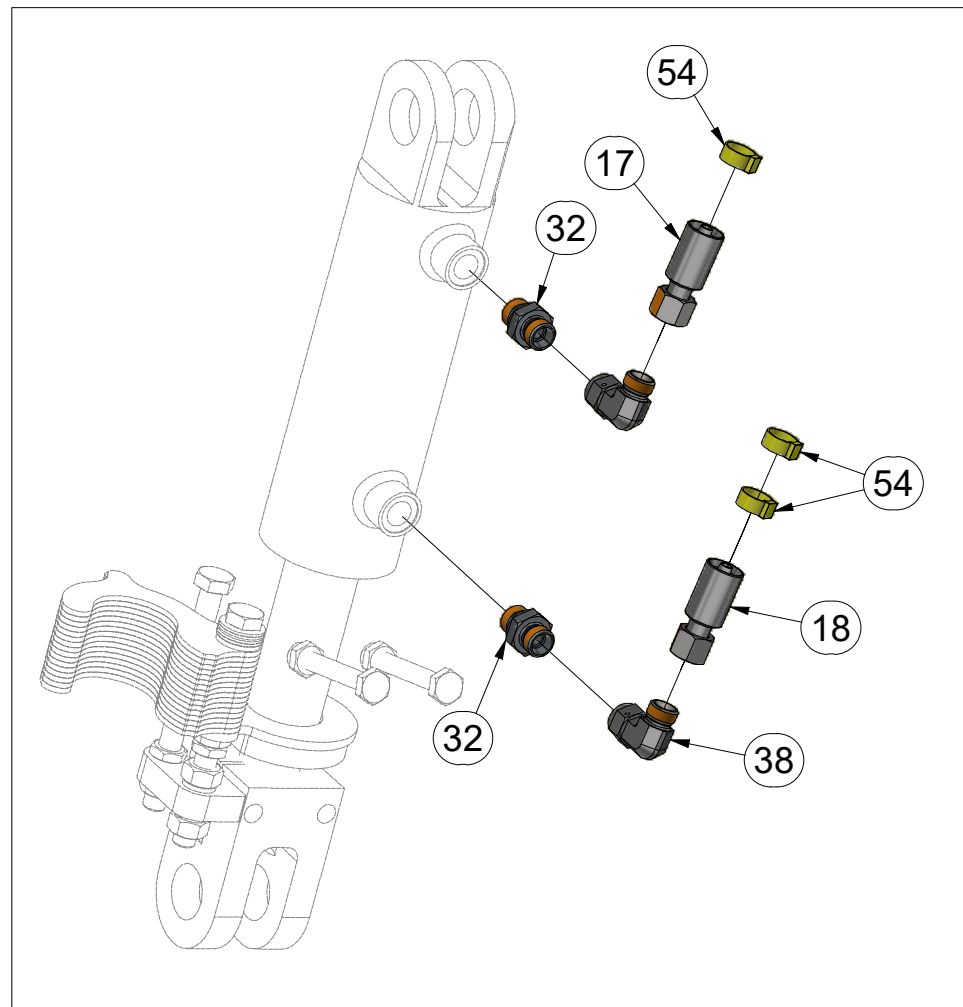

Ⓒ HYDRAULICKÝ ROZVOD - ZAHLUBOVÁNÍ

Ⓓ HYDRAULISCHE VERTEILUNG - EINSENKUNG

Ⓕ CONDUIT HYDRAULIQUE - L'ENFONCEMENT

Ⓖ HYDRAULIC DISTRIBUTION - RECESSING

Ⓡ ГИДРАВЛИЧЕСКОЕ РАСПРЕДЕЛЕНИЕ - ЗАГЛУБЛЕНИЕ

Ⓟ HYDRAULICZNY PRZEWÓD - ZAGŁĘBIENIA



VZ00046451

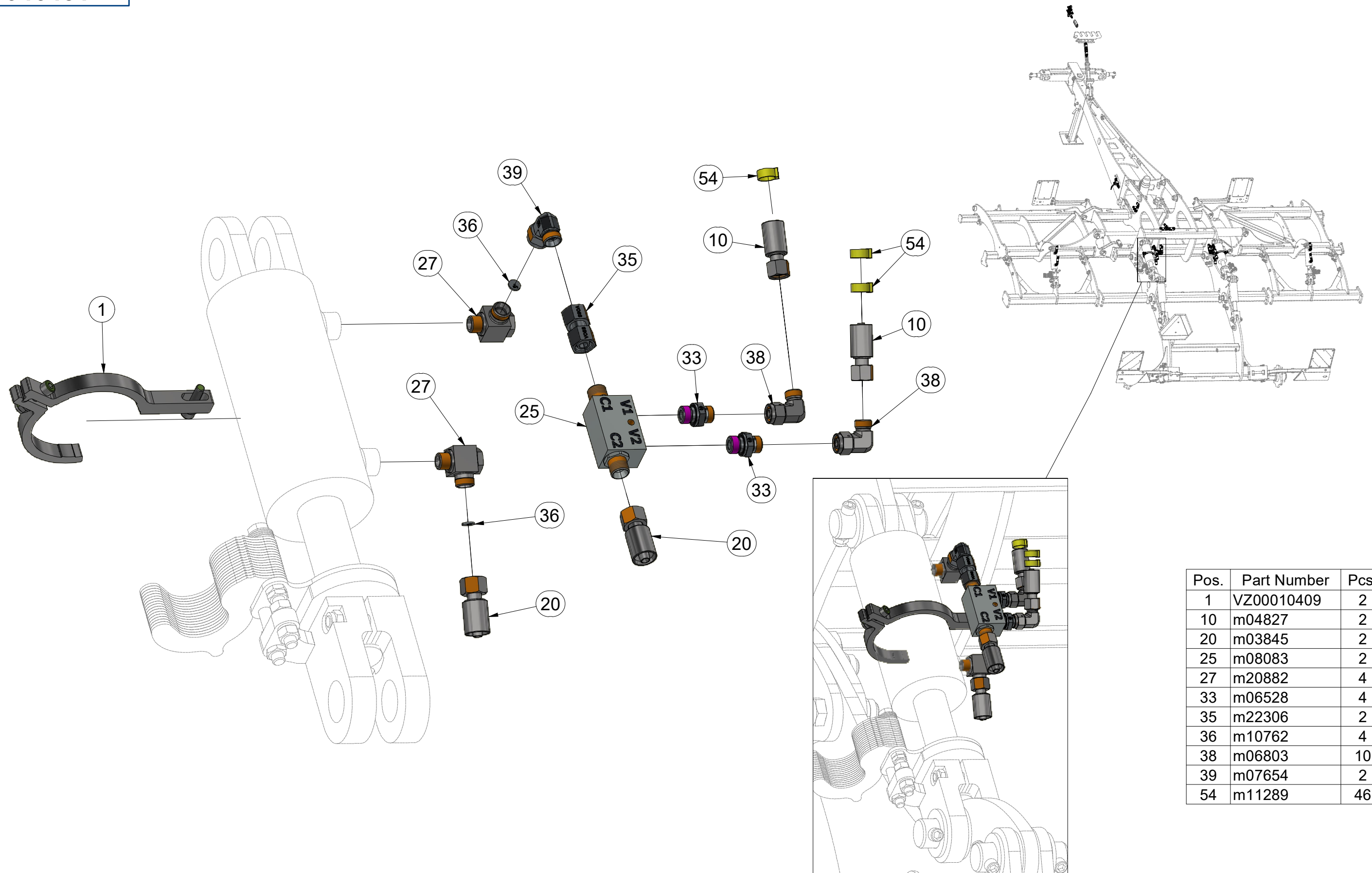

Pos.	Part Number	Pcs.
1	VZ00010409	2
10	m04827	2
20	m03845	2
25	m08083	2
27	m20882	4
33	m06528	4
35	m22306	2
36	m10762	4
38	m06803	10
39	m07654	2
54	m11289	46

ⒸZ HYDRAULICKÝ ROZVOD - ZAHLUBOVÁNÍ

Ⓓ HYDRAULISCHE VERTEILUNG - EINSENKUNG

Ⓕ CONDUIT HYDRAULIQUE - L'ENFONCEMENT

ⒸB HYDRAULIC DISTRIBUTION - RECESSING

ⒸU ГИДРАВЛИЧЕСКОЕ РАСПРЕДЕЛЕНИЕ - ЗАГЛУБЛЕНИЕ

ⒸL HYDRAULICZNY PRZEWÓD - ZAGŁĘBIENIA



VZ00046451

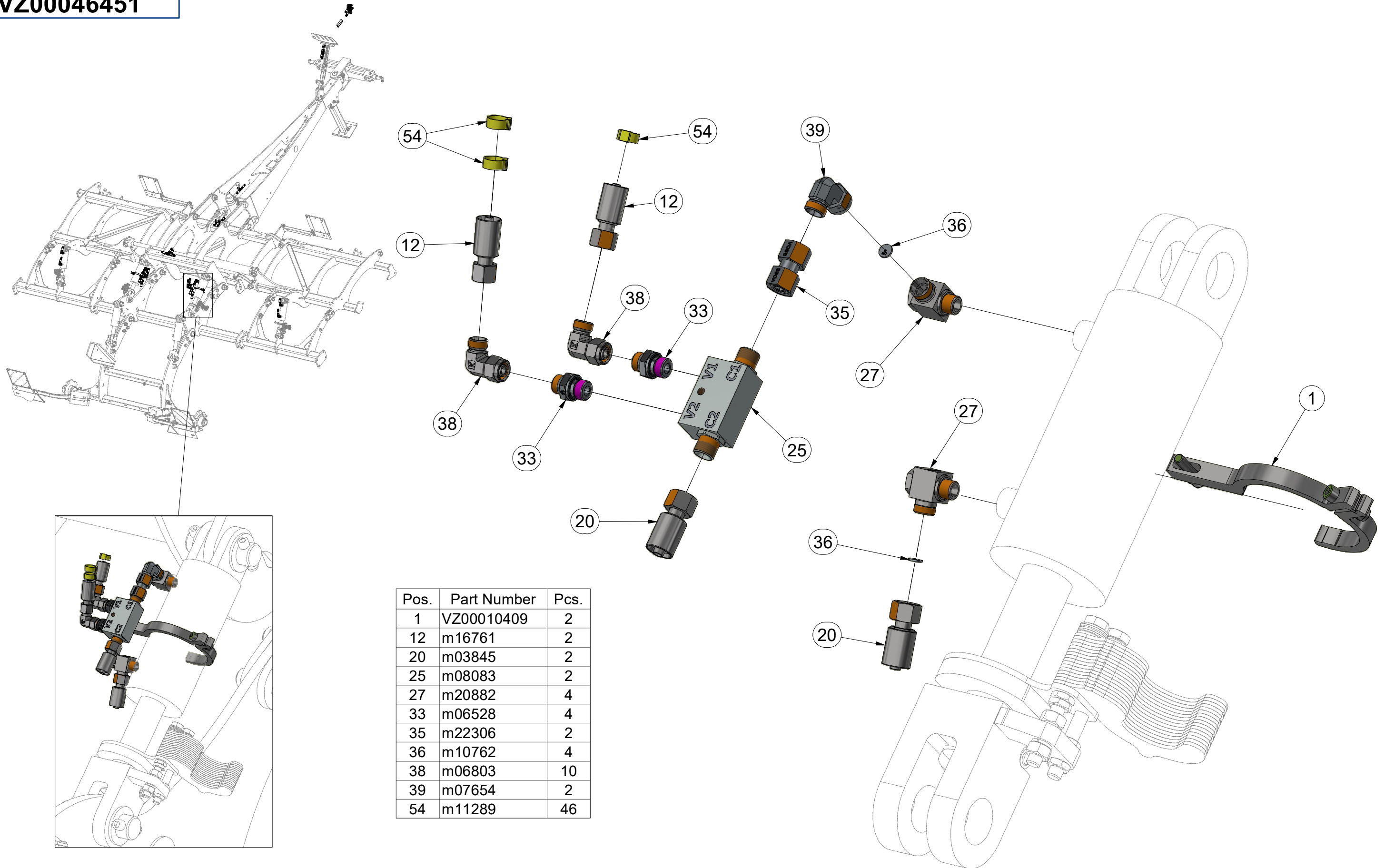

Pos.	Part Number	Pcs.
1	VZ00010409	2
12	m16761	2
20	m03845	2
25	m08083	2
27	m20882	4
33	m06528	4
35	m22306	2
36	m10762	4
38	m06803	10
39	m07654	2
54	m11289	46

ⒸZ HYDRAULICKÝ ROZVOD NÁPRAVY

Ⓓ HYDRAULISCHE VERTEILUNG ACHSE

Ⓕ CONDUIT HYDRAULIQUE DE L'ESSIEU

ⒸB HYDRAULIC AXLE DISTRIBUTION

ⒸR ГИДРАВЛИЧЕСКОЕ РАСПРЕДЕЛЕНИЕ ОСИ

ⒸL HYDRAULICZNY PRZEWÓD OSI

Farmet

VZ00046505

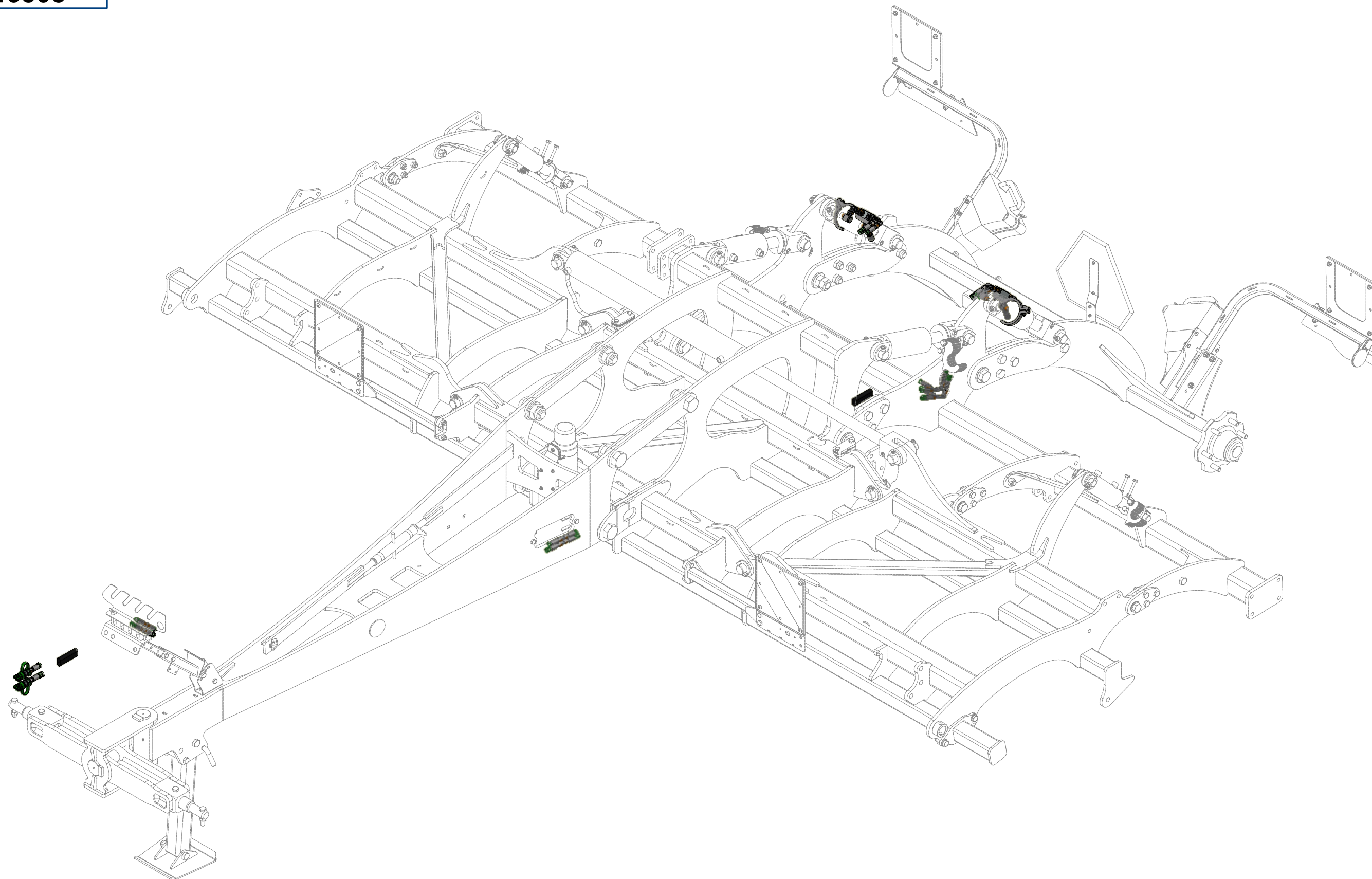

ⒸZ HYDRAULICKÝ ROZVOD NÁPRAVY

Ⓓ HYDRAULISCHE VERTEILUNG ACHSE

Ⓕ CONDUIT HYDRAULIQUE DE L'ESSIEU

ⒸB HYDRAULIC AXLE DISTRIBUTION

ⒸR ГИДРАВЛИЧЕСКОЕ РАСПРЕДЕЛЕНИЕ ОСИ

ⒸL HYDRAULICZNY PRZEWÓD OSI



VZ00046505

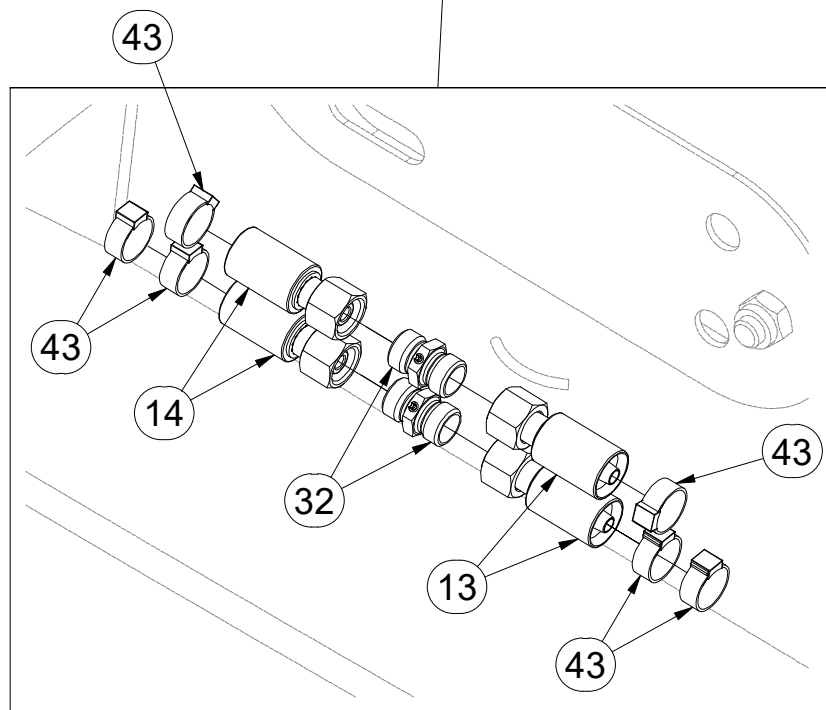
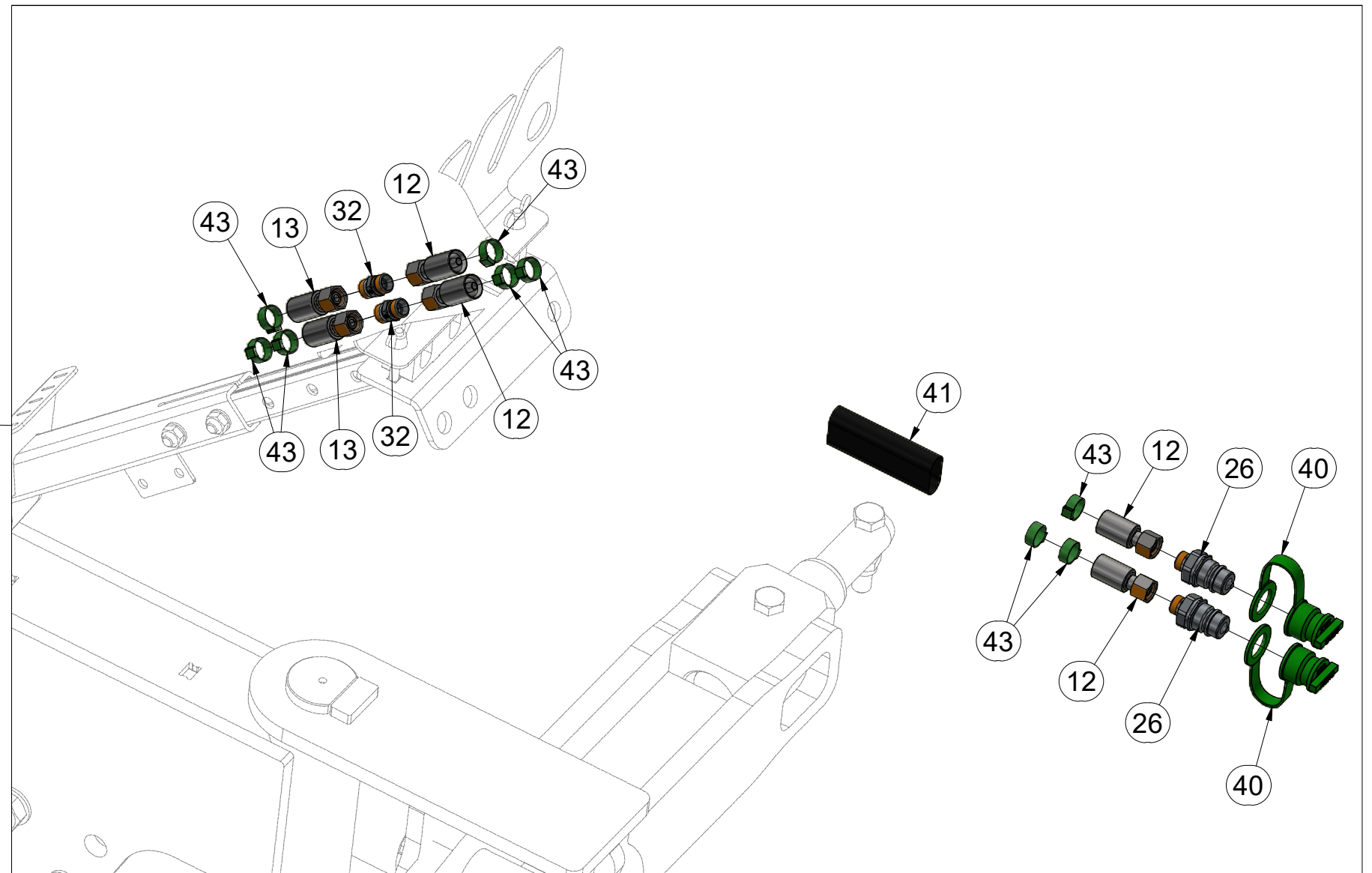
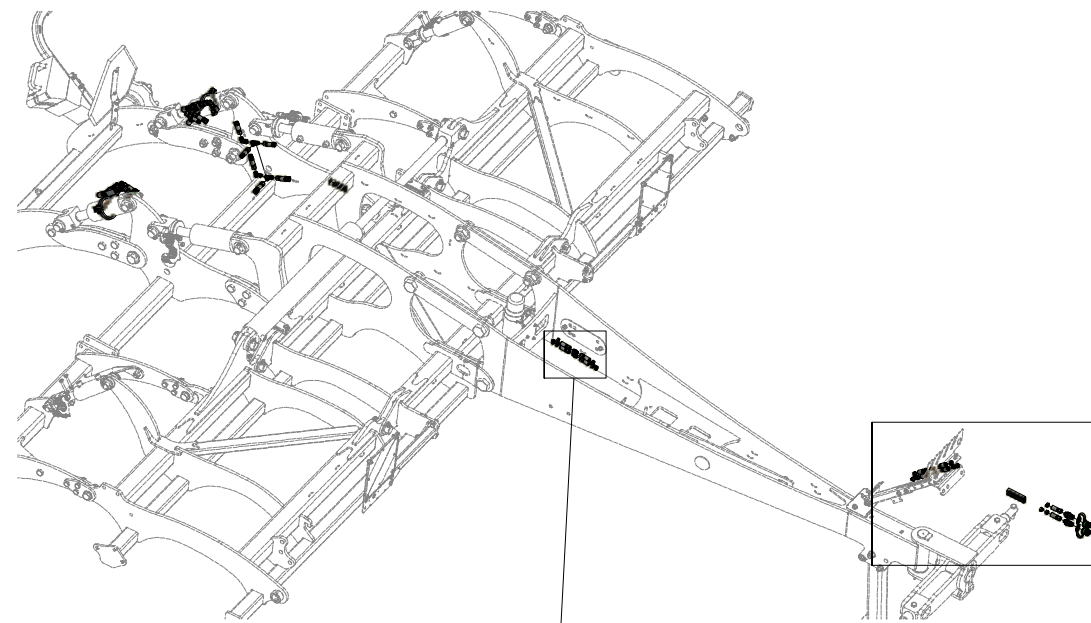

Pos.	Part Number	Pcs.
12	m11696	2
13	m07650	2
14	m05763	2
26	m03849	2
32	m03213	4
40	m04098	2
41	m11183	2
43	m11282	30

Ⓒ HYDRAULICKÝ ROZVOD NÁPRAVY

Ⓓ HYDRAULISCHE VERTEILUNG ACHSE

Ⓕ CONDUIT HYDRAULIQUE DE L'ESSIEU

Ⓖ HYDRAULIC AXLE DISTRIBUTION

Ⓡ ГИДРАВЛИЧЕСКОЕ РАСПРЕДЕЛЕНИЕ ОСИ

Ⓟ HYDRAULICZNY PRZEWÓD OSI



VZ00046505

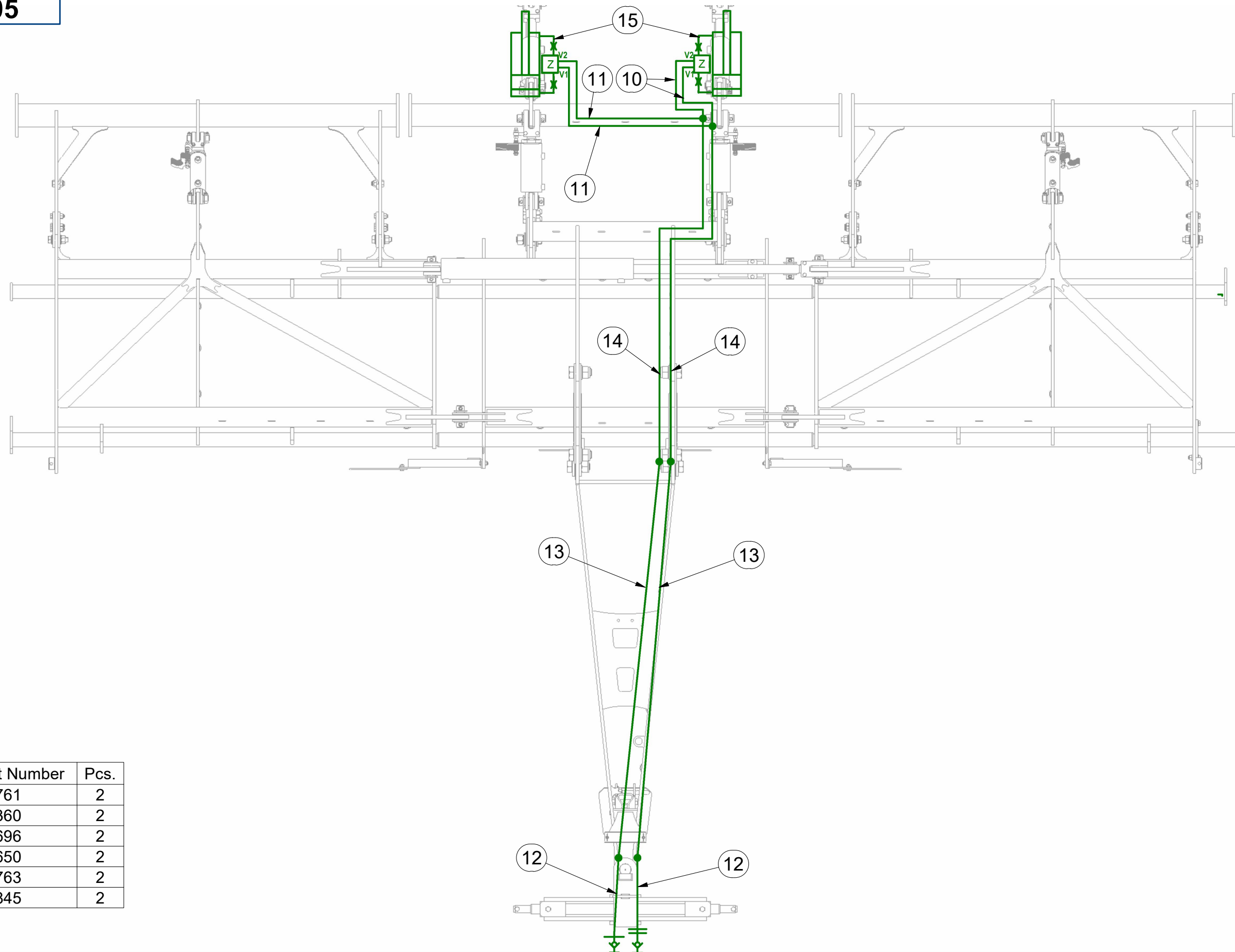

Pos.	Part Number	Pcs.
10	m04761	2
11	m07360	2
12	m11696	2
13	m07650	2
14	m05763	2
15	m03845	2

ⒸZ HYDRAULICKÝ ROZVOD NÁPRAVY

Ⓓ HYDRAULISCHE VERTEILUNG ACHSE

Ⓕ CONDUIT HYDRAULIQUE DE L'ESSIEU

ⒸB HYDRAULIC AXLE DISTRIBUTION

ⒸU ГИДРАВЛИЧЕСКОЕ РАСПРЕДЕЛЕНИЕ ОСИ

ⒸL HYDRAULICZNY PRZEWÓD OSI



VZ00046505

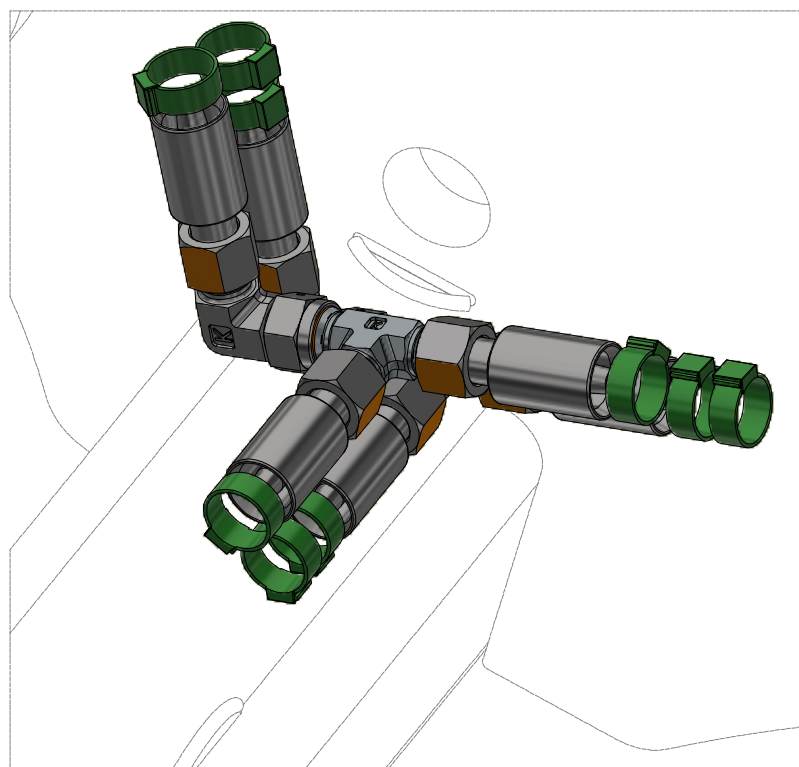
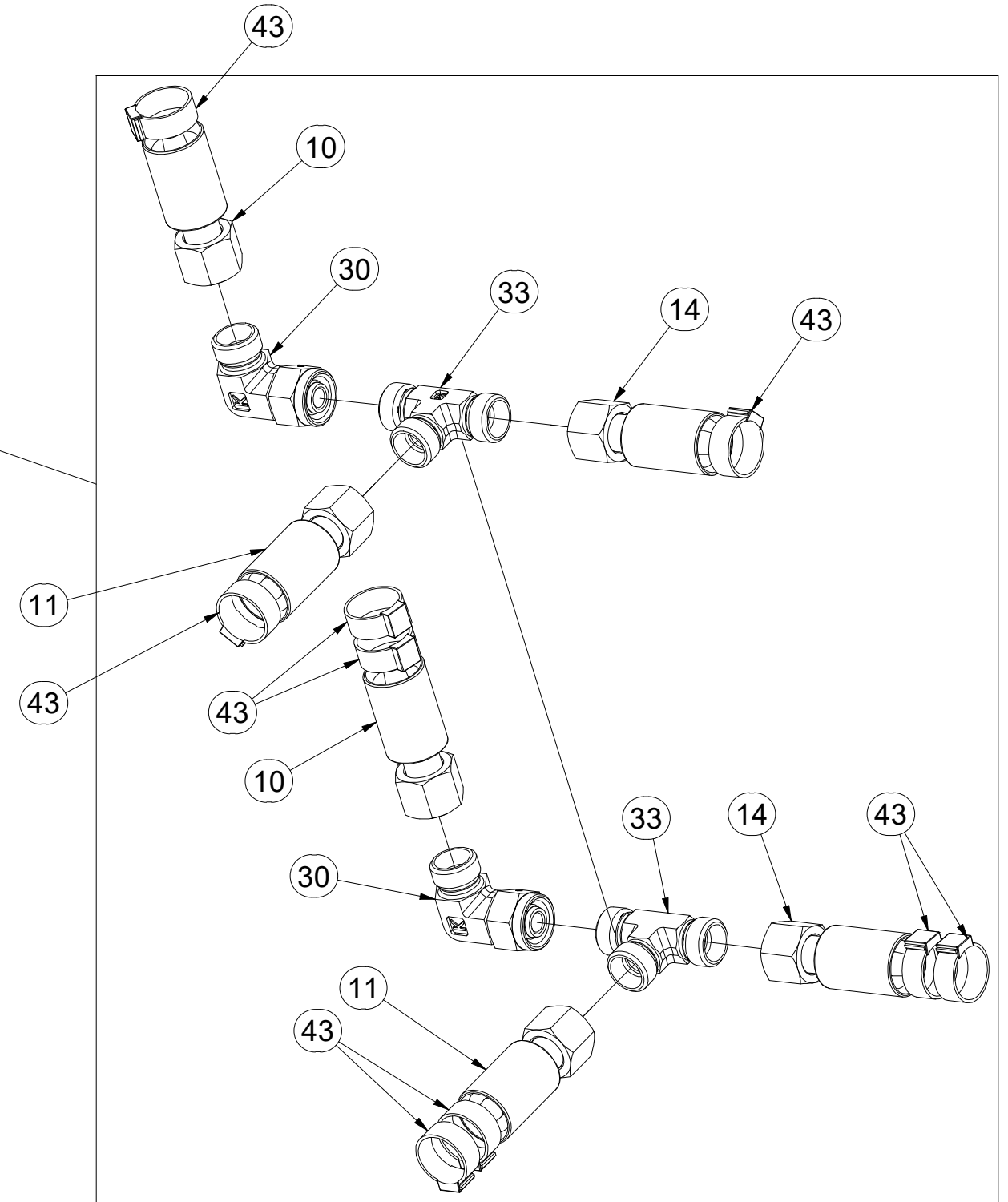
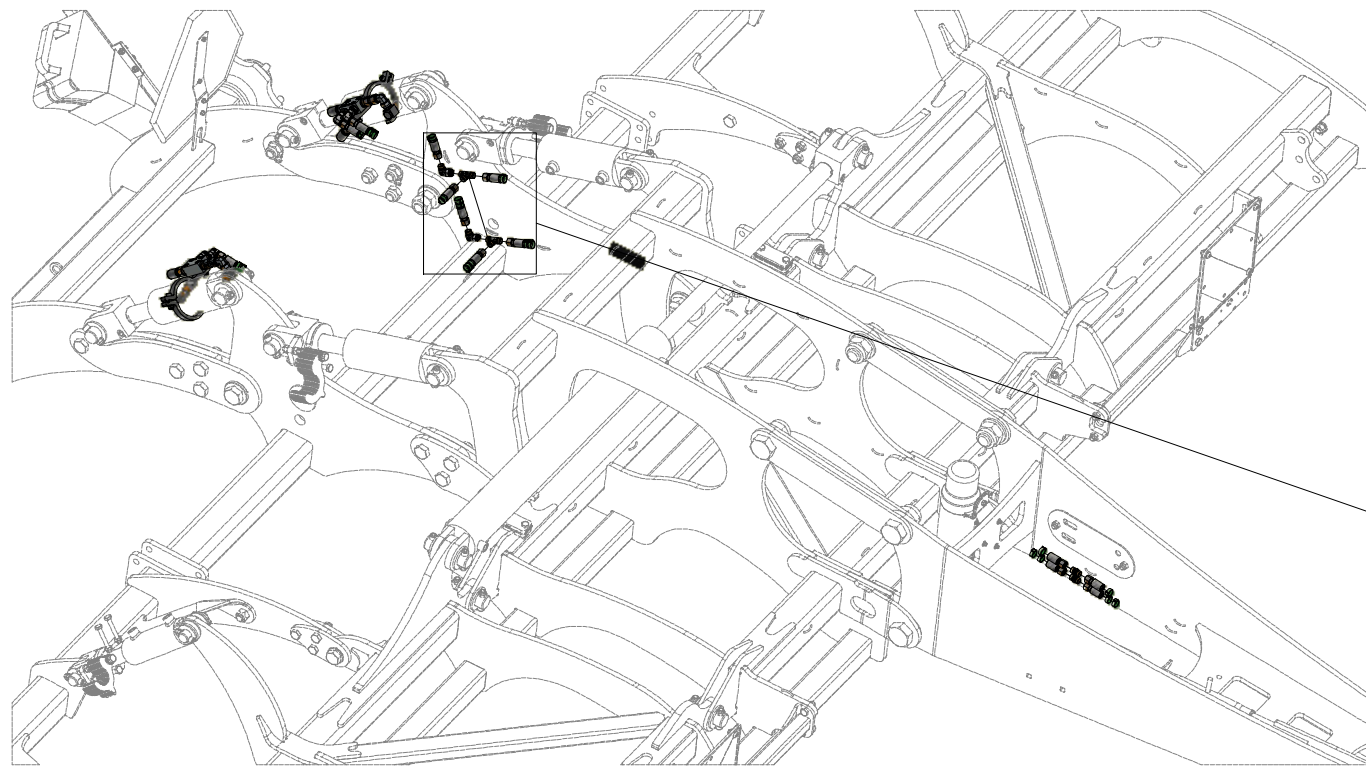

Pos.	Part Number	Pcs.
10	m04761	2
11	m07360	2
14	m05763	2
30	m06803	6
33	m03889	2
43	m11282	30

ⒸZ HYDRAULICKÝ ROZVOD NÁPRAVY

Ⓓ HYDRAULISCHE VERTEILUNG ACHSE

Ⓕ CONDUIT HYDRAULIQUE DE L'ESSIEU

ⒸB HYDRAULIC AXLE DISTRIBUTION

ⒸU ГИДРАВЛИЧЕСКОЕ РАСПРЕДЕЛЕНИЕ ОСИ

ⒸL HYDRAULICZNY PRZEWÓD OSI



VZ00046505

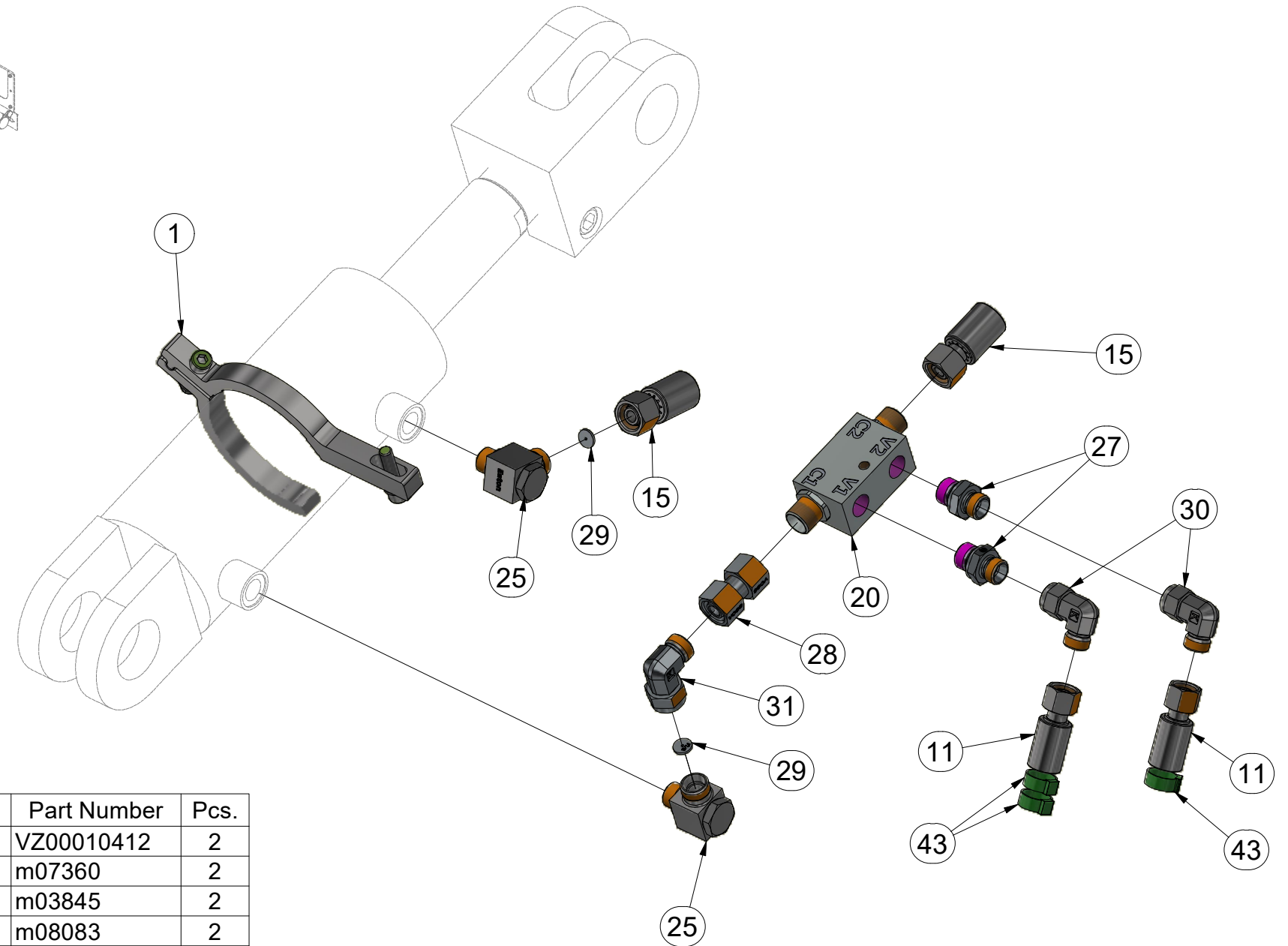
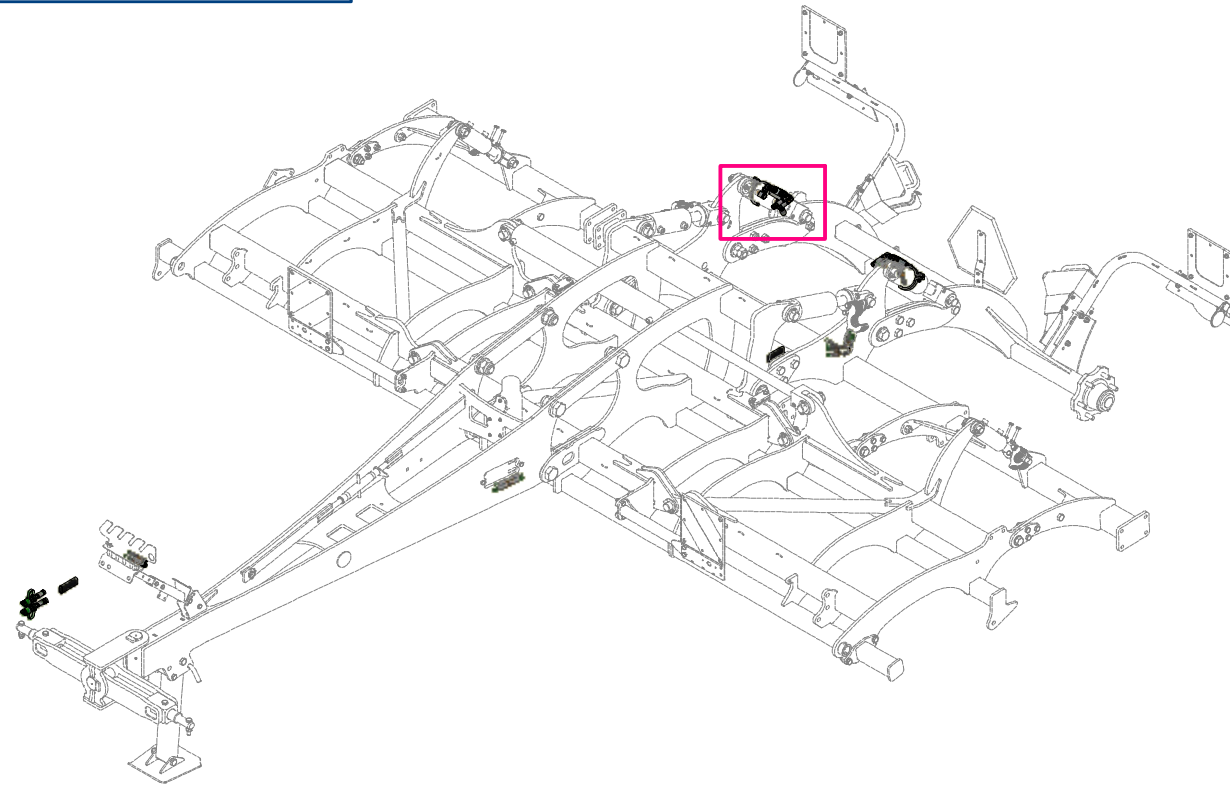

Pos.	Part Number	Pcs.
1	VZ00010412	2
11	m07360	2
15	m03845	2
20	m08083	2
25	m20882	4
27	m06528	4
28	m22306	2
29	m10776	4
30	m06803	6
31	m07654	2
43	m11282	30

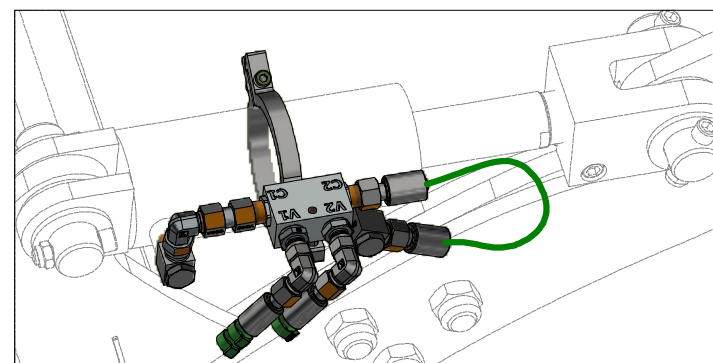

ⒸZ HYDRAULICKÝ ROZVOD NÁPRAVY

Ⓓ HYDRAULISCHE VERTEILUNG ACHSE

Ⓔ CONDUIT HYDRAULIQUE DE L'ESSIEU

ⒸB HYDRAULIC AXLE DISTRIBUTION

ⒸU ГИДРАВЛИЧЕСКОЕ РАСПРЕДЕЛЕНИЕ ОСИ

ⒸL HYDRAULICZNY PRZEWÓD OSI



VZ00046505

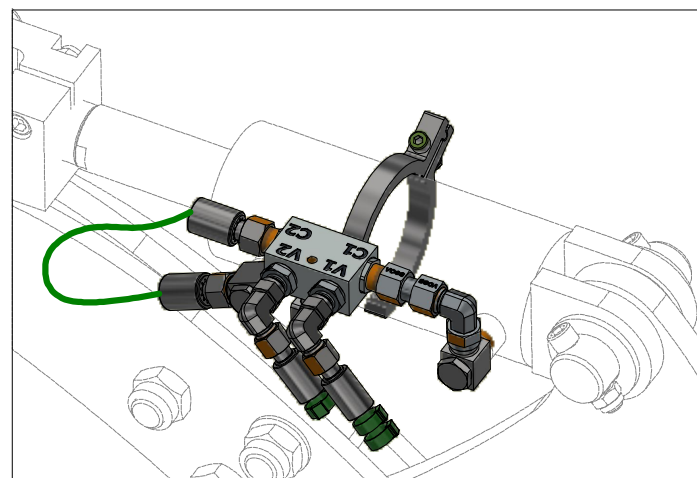
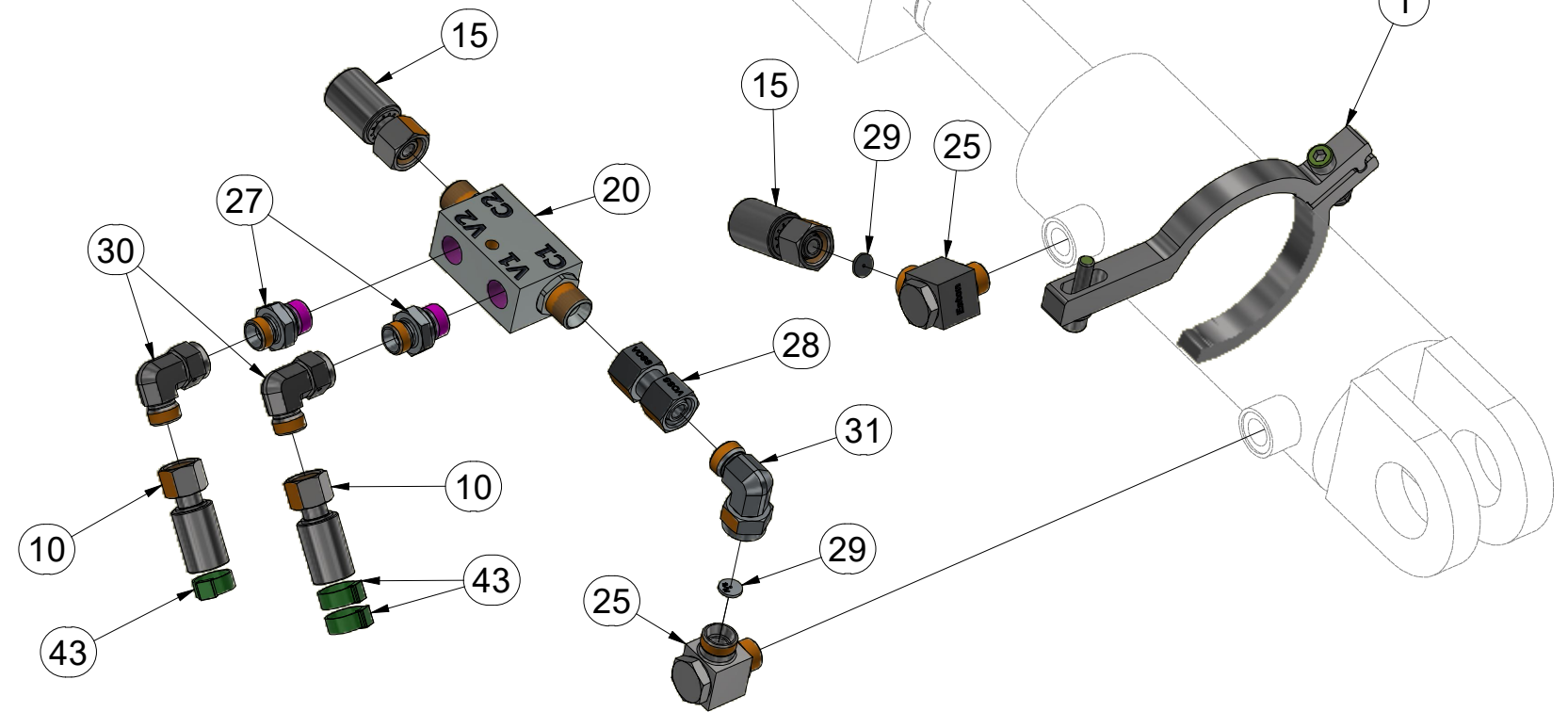
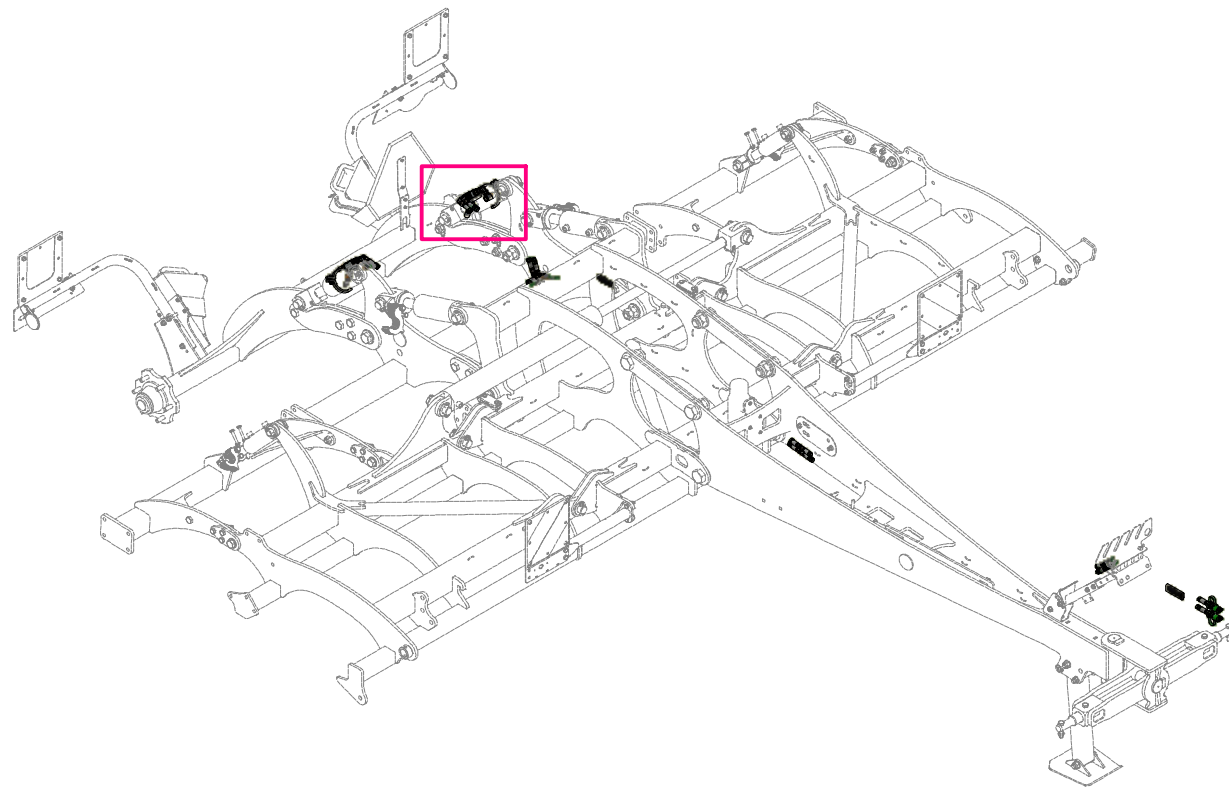

Pos.	Part Number	Pcs.
1	VZ00010412	2
10	m04761	2
15	m03845	2
20	m08083	2
25	m20882	4
27	m06528	4
28	m22306	2
29	m10776	4
30	m06803	6
31	m07654	2
43	m11282	30

- ⒸZ DRŽÁK
- Ⓓ HALTER
- Ⓕ SUPPORT

- ⒼB HOLDER
- ⒶRU ДЕРЖАТЕЛЬ
- ⒶPL UCHWYT



VZ00010409

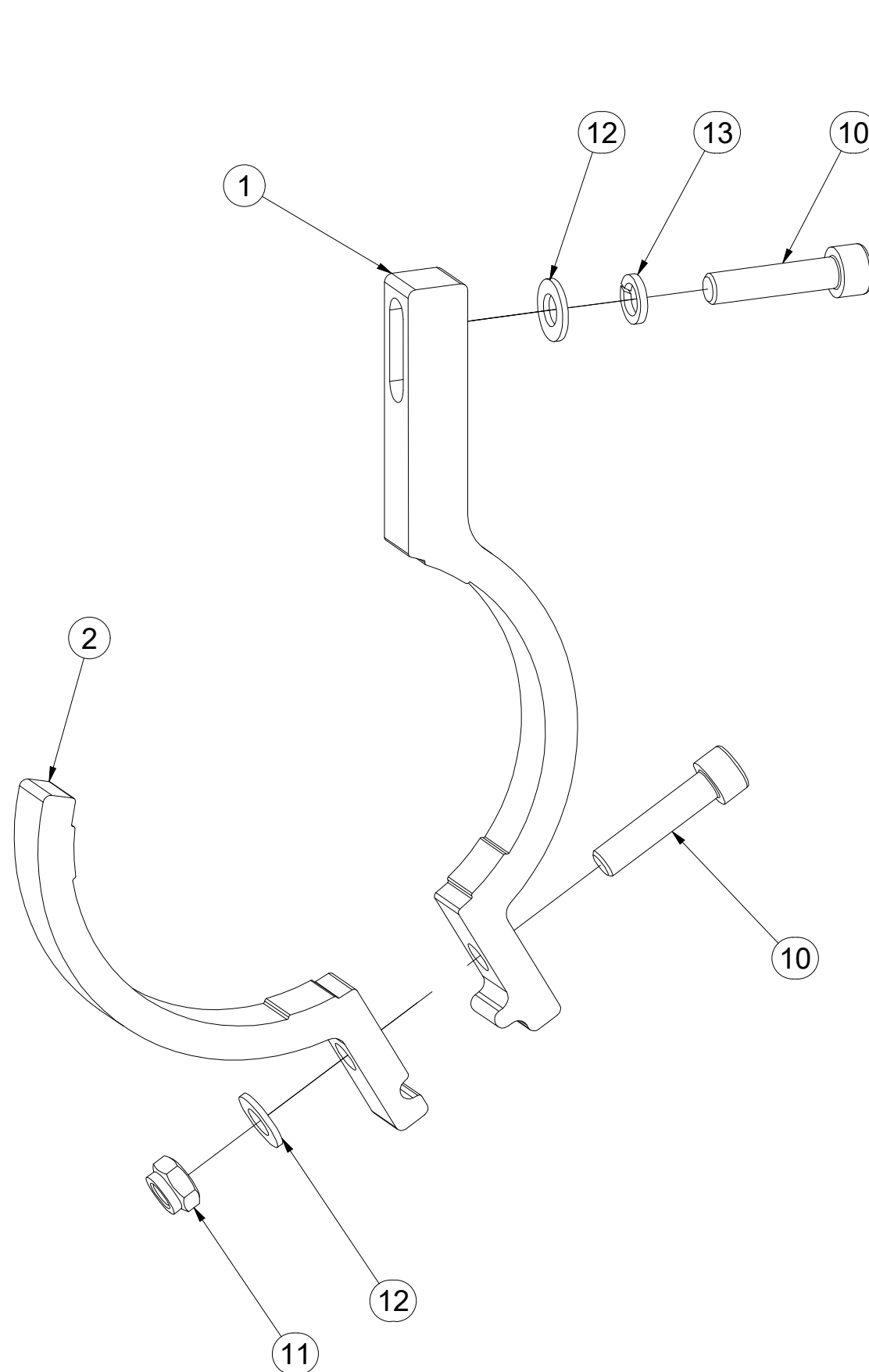

Pos.	Part Number	Pcs.
1	VZ00010410	1
2	VZ00010408	1
10	m09464	2
11	m04503	1
12	m01203	2
13	m01202	1

- Ⓒ DRŽÁK
- Ⓓ HALTER
- Ⓕ SUPPORT

- Ⓖ HOLDER
- Ⓡ ДЕРЖАТЕЛЬ
- Ⓢ UCHWYT



VZ00010412

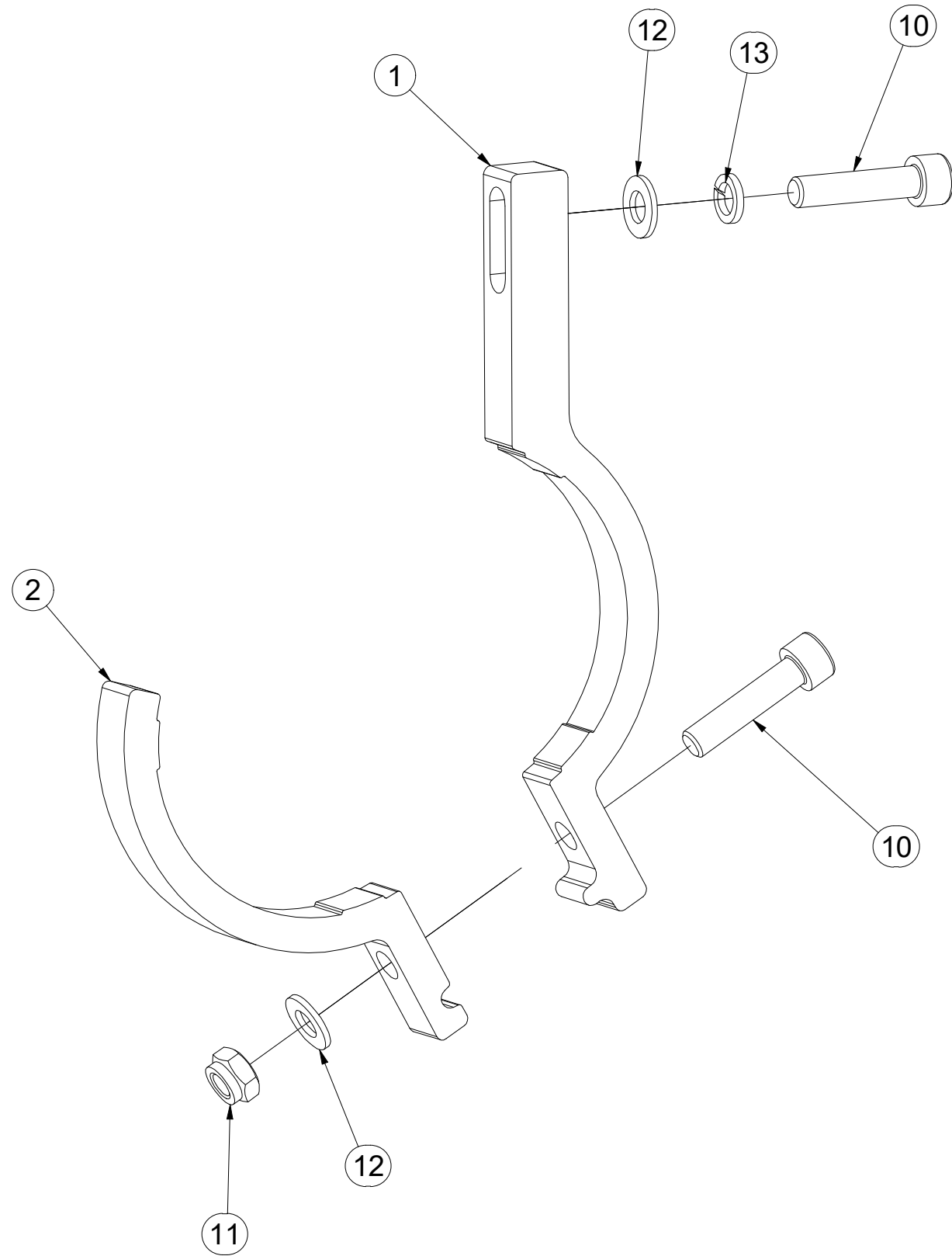

Pos.	Part Number	Pcs.
1	VZ00010413	1
2	VZ00010411	1
10	m09464	2
11	m04503	1
12	m01203	2
13	m01202	1

Ⓒ PÍSTNICE 90/45-830

Ⓓ KOLBENSTANGE 90/45-830

Ⓕ TIGE DE PISTON 90/45-830

Ⓖ PISTON ROD 90/45-830

Ⓡ ЦИЛИНДР 90/45-830

Ⓟ TRZPIEŃ TŁOKA 90/45-830



VZ00045743

Pos.	Part Number	Pcs.
1	m25179	1
2	m15149	1
5	m14867	1
6	m21001	1

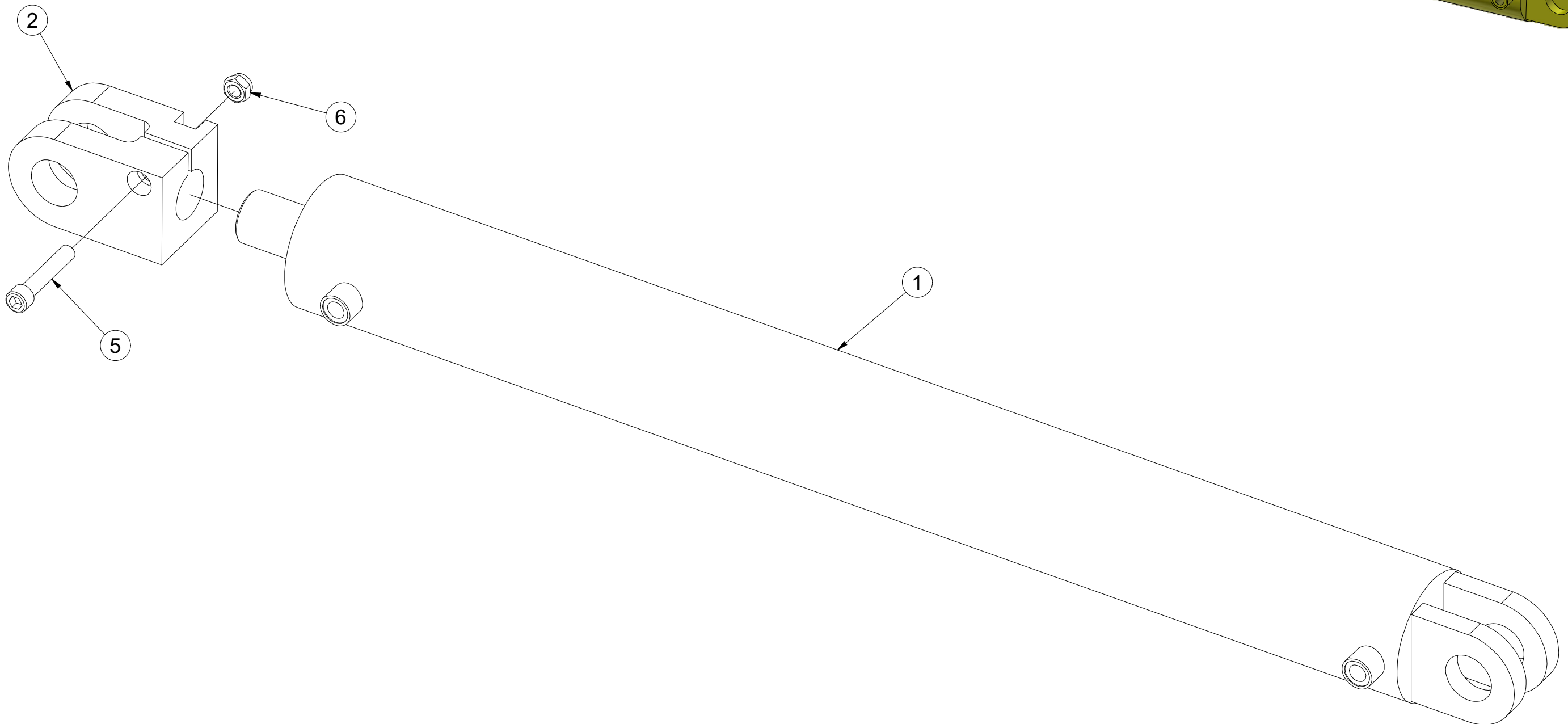
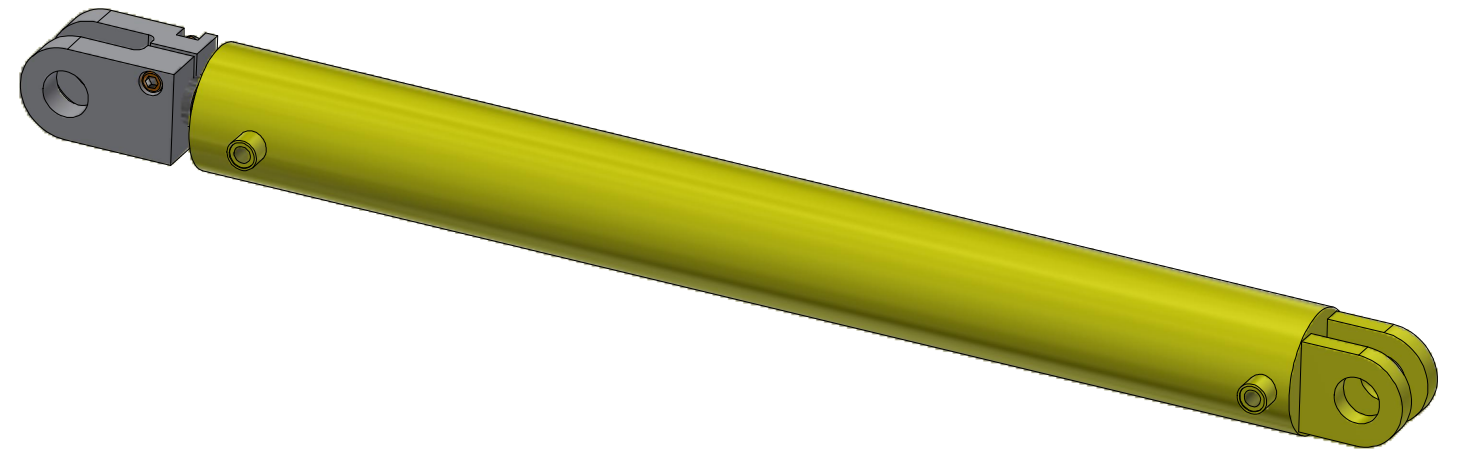

Ⓒ PÍSTNICE 63/40-95

Ⓓ KOLBENSTANGE 63/40-95

Ⓕ TIGE DE PISTON 63/40-95

Ⓖ PISTON ROD 63/40-95

Ⓡ ЦИЛИНДР 63/40-95

Ⓟ TRZPIEŃ TŁOKA 63/40-95

Farmet

VZ00045789

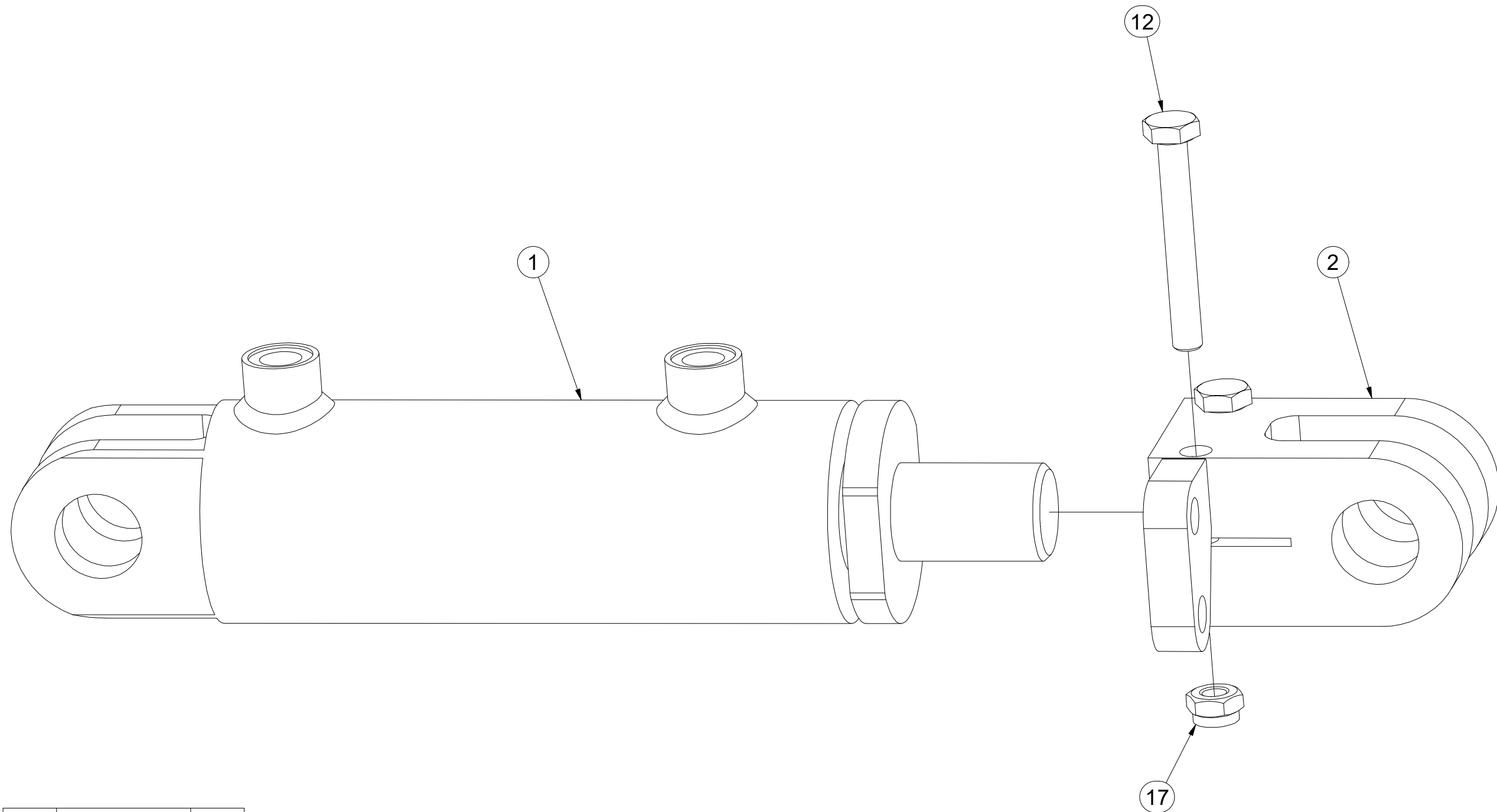

Pos.	Part Number	Pcs.
1	m25172	1
2	m22564	1
12	m15202	2
17	m03775	2
22	m17728	4

Ⓒ PÍSTNICE 63/40-95

Ⓓ KOLBENSTANGE 63/40-95

Ⓕ TIGE DE PISTON 63/40-95

Ⓖ PISTON ROD 63/40-95

Ⓡ ЦИЛИНДР 63/40-95

Ⓟ TRZPIEŃ TŁOKA 63/40-95



VZ00045789

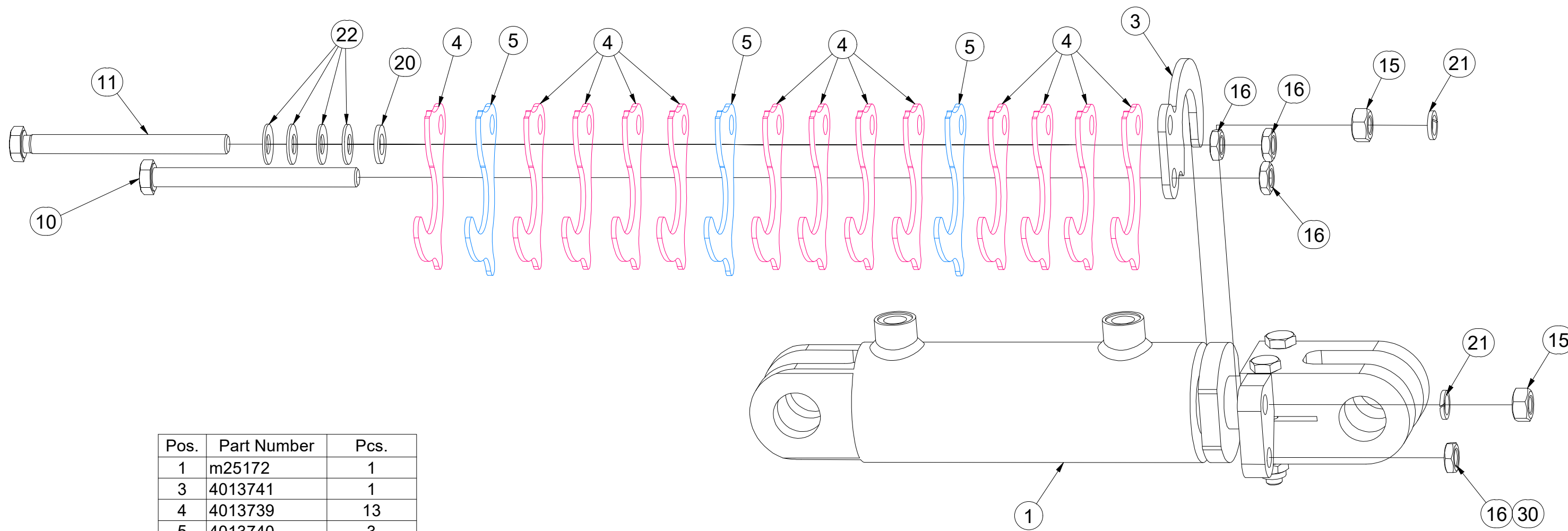

Pos.	Part Number	Pcs.
1	m25172	1
3	4013741	1
4	4013739	13
5	4013740	3
10	m04981	1
11	m14232	1
15	m01305	2
16	m14233	4
20	m01214	1
21	m03988	2
22	m17728	4
30	m10516	0,10 ml

Ⓒ PÍSTNICE 63/40-95

Ⓓ KOLBENSTANGE 63/40-95

Ⓕ TIGE DE PISTON 63/40-95

Ⓖ PISTON ROD 63/40-95

Ⓡ ЦИЛИНДР 63/40-95

Ⓟ TRZPIEŃ TŁOKA 63/40-95



VZ00045796

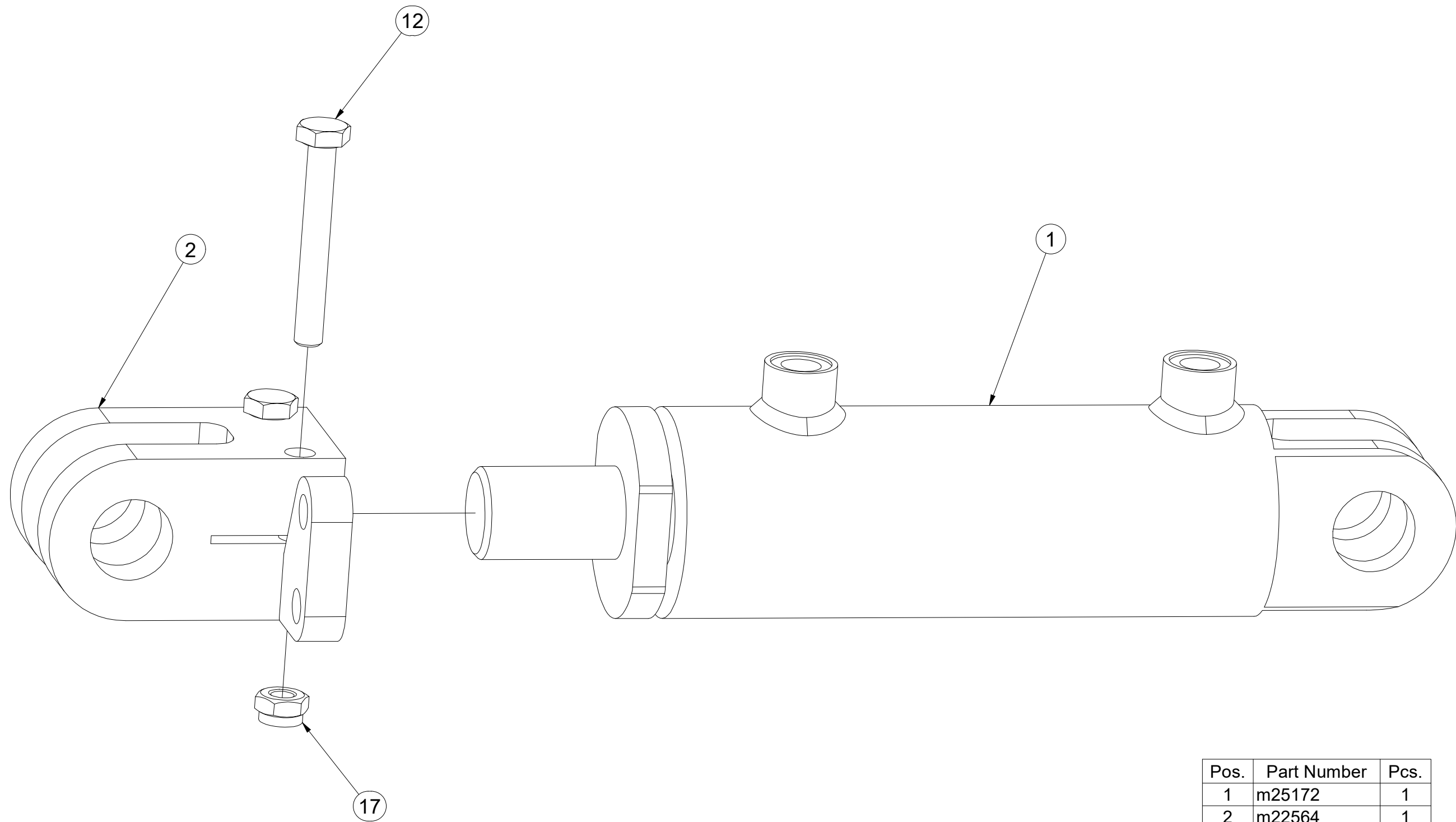

Pos.	Part Number	Pcs.
1	m25172	1
2	m22564	1
12	m15202	2
17	m03775	2
22	m17728	4

Ⓒ PÍSTNICE 63/40-95

Ⓓ KOLBENSTANGE 63/40-95

Ⓕ TIGE DE PISTON 63/40-95

Ⓖ PISTON ROD 63/40-95

Ⓡ ЦИЛИНДР 63/40-95

Ⓟ TRZPIEŃ TŁOKA 63/40-95



VZ00045796

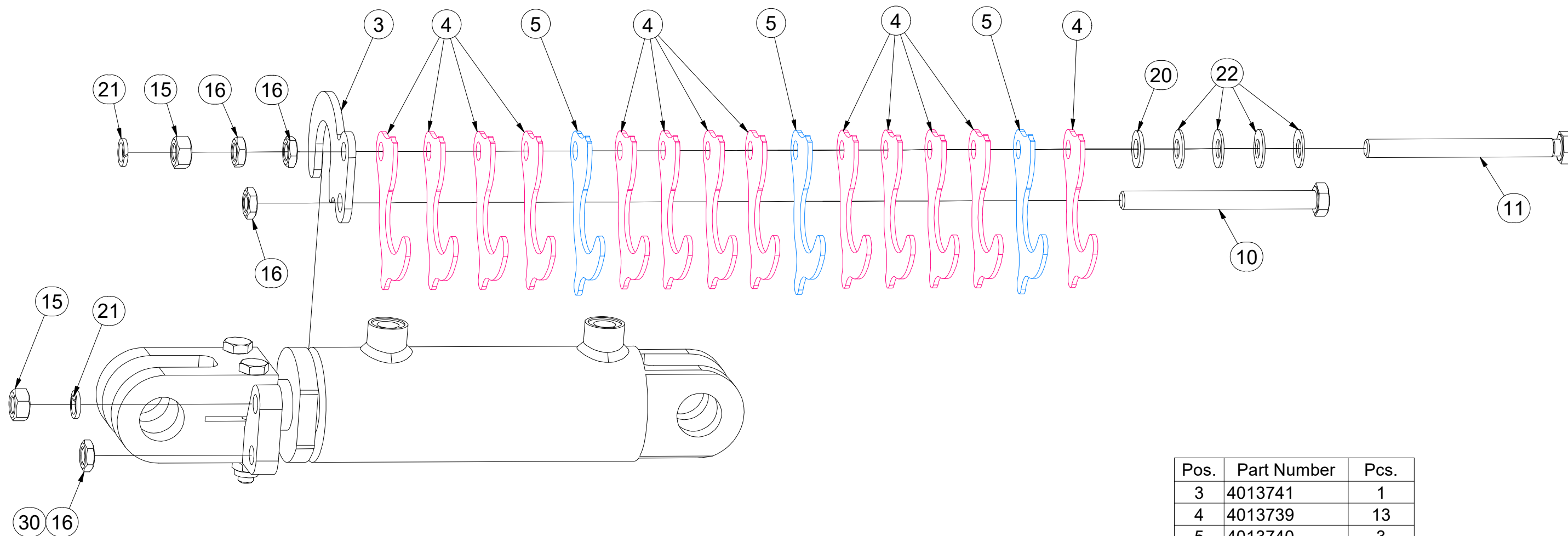

Pos.	Part Number	Pcs.
3	4013741	1
4	4013739	13
5	4013740	3
10	m04981	1
11	m14232	1
15	m01305	2
16	m14233	4
20	m01214	1
21	m03988	2
22	m17728	4
30	m10516	0,10 ml

Ⓒ PÍSTNICE 80/45-100

Ⓓ KOLBENSTANGE 80/45-100

Ⓕ TIGE DE PISTON 80/45-100

Ⓖ PISTON ROD 80/45-100

Ⓡ ЦИЛИНДР 80/45-100

Ⓟ TRZPIEŃ TŁOKA 80/45-100



VZ00046200

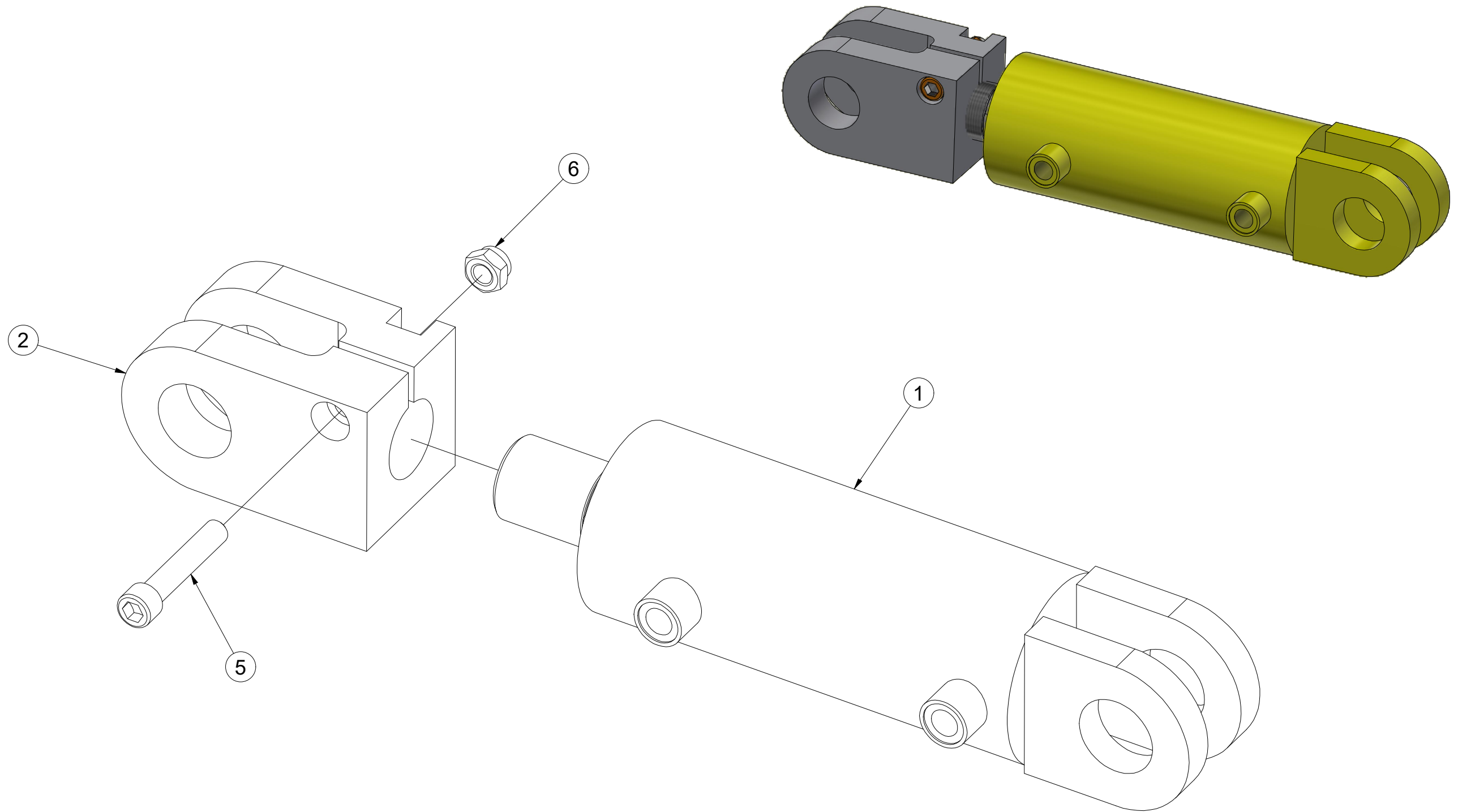

Pos.	Part Number	Pcs.
1	m25184	1
2	m15149	1
5	m14867	1
6	m21001	1

Ⓒ PÍSTNICE 90/45-100

Ⓓ KOLBENSTANGE 90/45-100

Ⓕ TIGE DE PISTON 90/45-100

Ⓖ PISTON ROD 90/45-100

Ⓡ ЦИЛИНДР 90/45-100

Ⓟ TRZPIEŃ TŁOKA 90/45-100

Farmet

VZ00046276

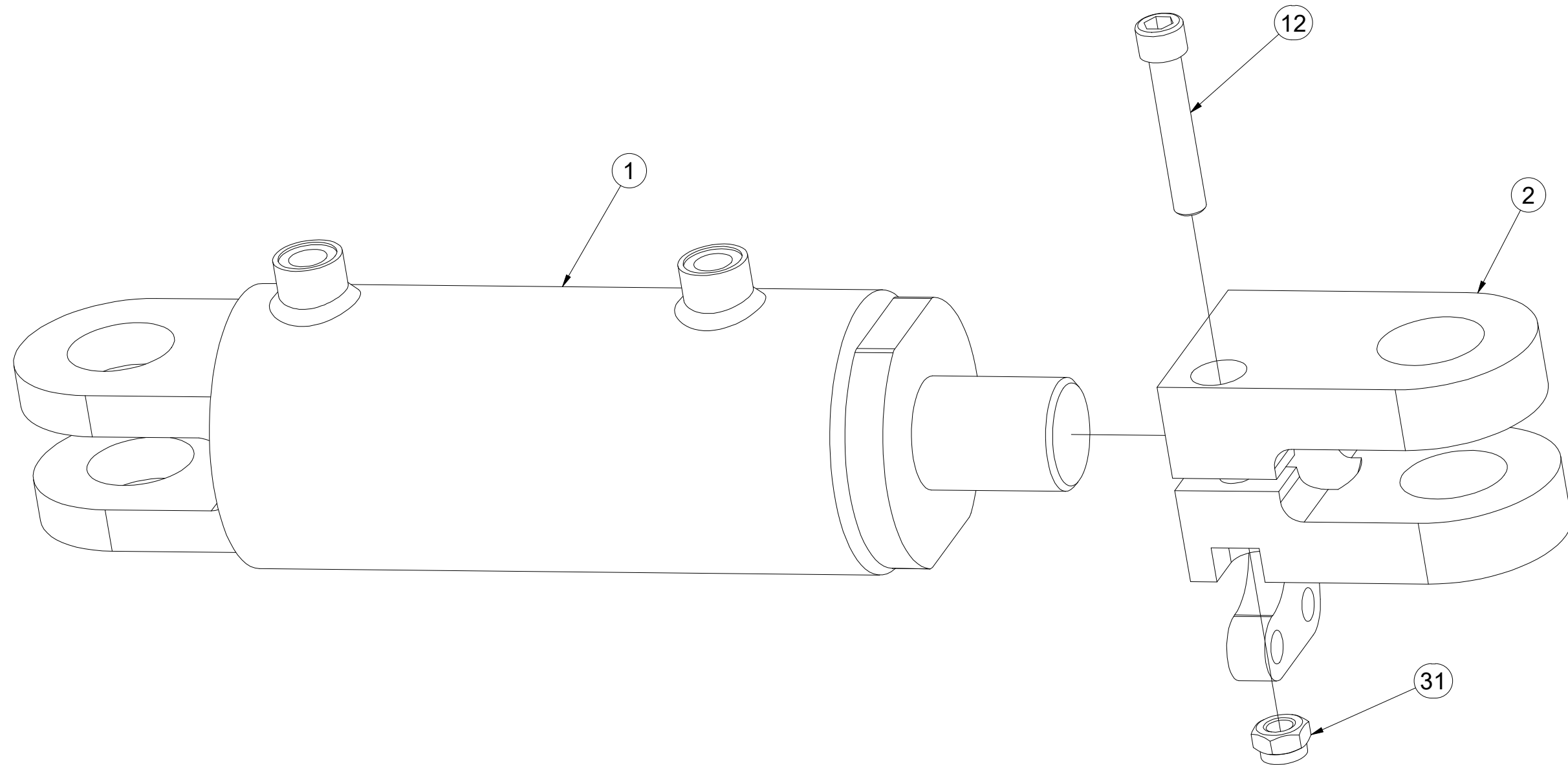

Pos.	Part Number	Pcs.
1	m25182	1
2	m20347	1
12	m14867	1
22	m17728	4
31	m21001	1

Ⓒ PÍSTNICE 90/45-100

Ⓓ KOLBENSTANGE 90/45-100

Ⓕ TIGE DE PISTON 90/45-100

Ⓖ PISTON ROD 90/45-100

Ⓡ ЦИЛИНДР 90/45-100

Ⓟ TRZPIEŃ TŁOKA 90/45-100



VZ00046276

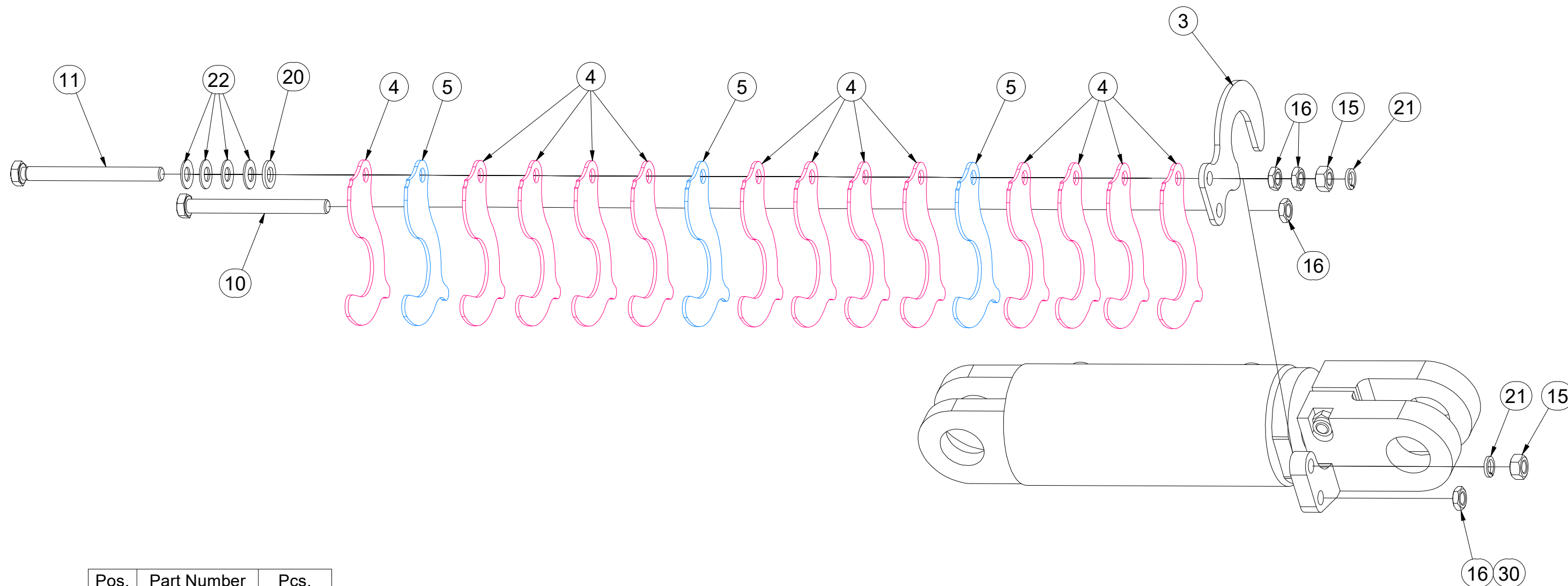

Pos.	Part Number	Pcs.
3	4013785	1
4	4013786	13
5	4013787	3
10	m04981	1
11	m14232	1
15	m10439	2
16	m14233	4
20	m01214	1
21	m03988	2
22	m17728	4
30	m10516	0,10 ml

Ⓒ PÍSTNICE 90/45-100

Ⓓ KOLBENSTANGE 90/45-100

Ⓕ TIGE DE PISTON 90/45-100

Ⓖ PISTON ROD 90/45-100

Ⓡ ЦИЛИНДР 90/45-100

Ⓟ TRZPIEŃ TŁOKA 90/45-100

Farmet

VZ00046358

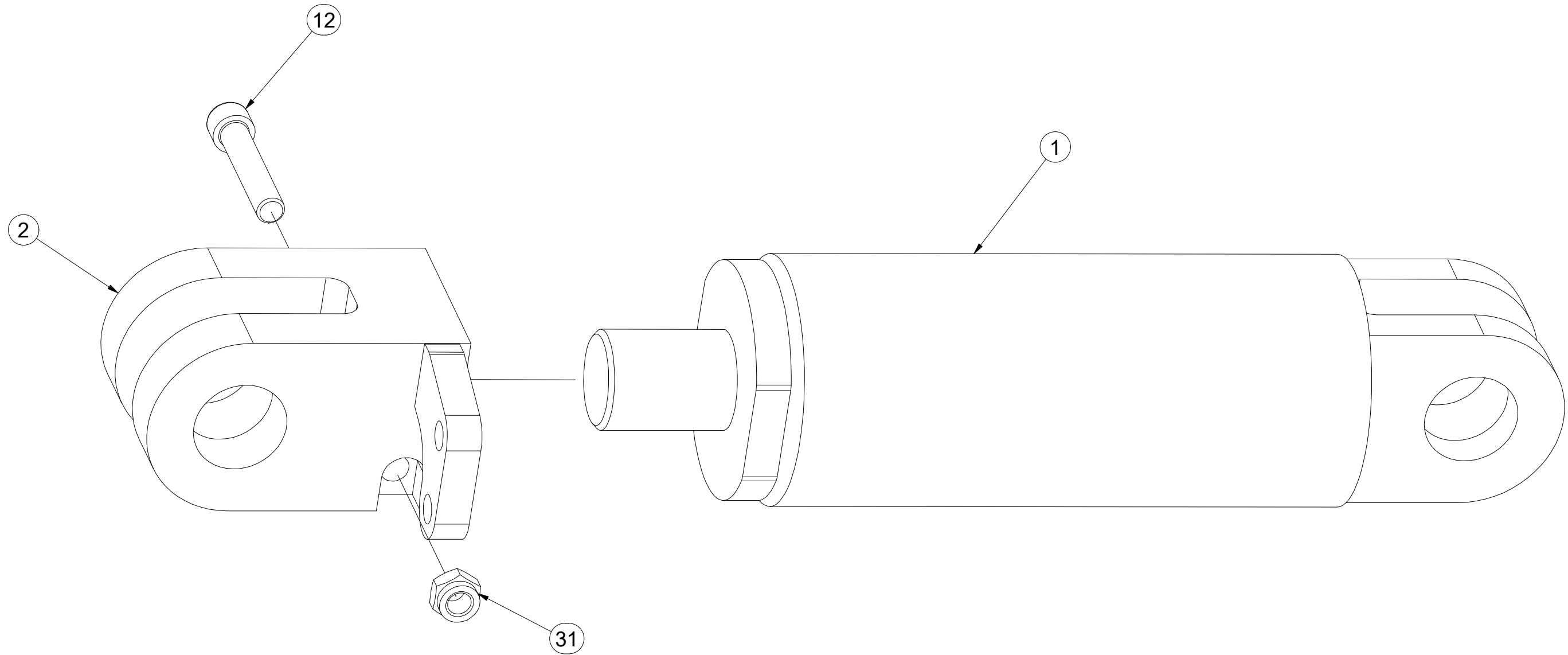

Pos.	Part Number	Pcs.
1	m25182	1
2	m20347	1
12	m14867	1
22	m17728	4
31	m21001	1

Ⓒ PÍSTNICE 90/45-100

Ⓓ KOLBENSTANGE 90/45-100

Ⓕ TIGE DE PISTON 90/45-100

Ⓖ PISTON ROD 90/45-100

Ⓡ ЦИЛИНДР 90/45-100

Ⓟ TRZPIEŃ TŁOKA 90/45-100



VZ00046358

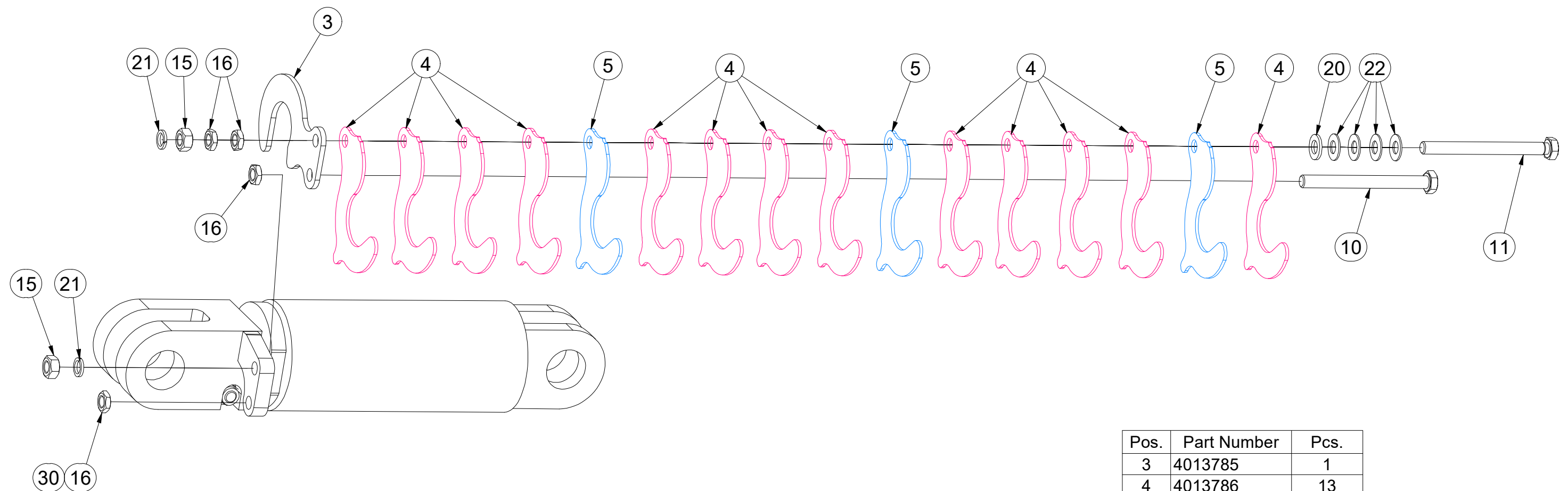

Pos.	Part Number	Pcs.
3	4013785	1
4	4013786	13
5	4013787	3
10	m04981	1
11	m14232	1
15	m10439	2
16	m14233	4
20	m01214	1
21	m03988	2
22	m17728	4
30	m10516	0,10 ml

☉ SAMOLEPKY STROJE

☉ AUFKLEBER MASCHINEN

☉ VOITURE MACHINES

☉ STICKERS MACHINES

☉ СТИКЕРЫ МАШИНЫ

☉ NAKLEJKI MASZYNY



VZ00039257

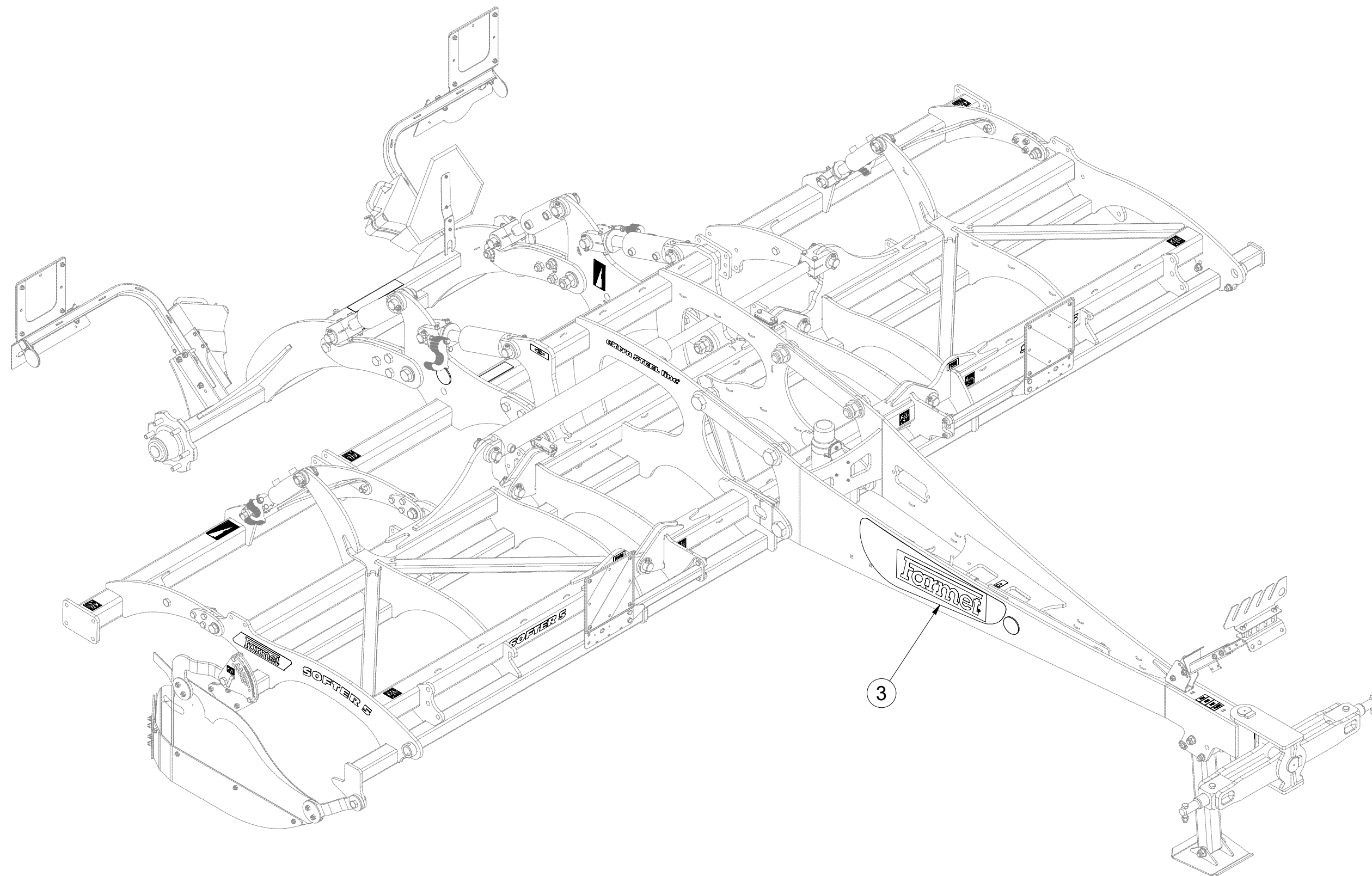

Pos.	Part Number	Pcs.
3	m24190	1

VZ00039257

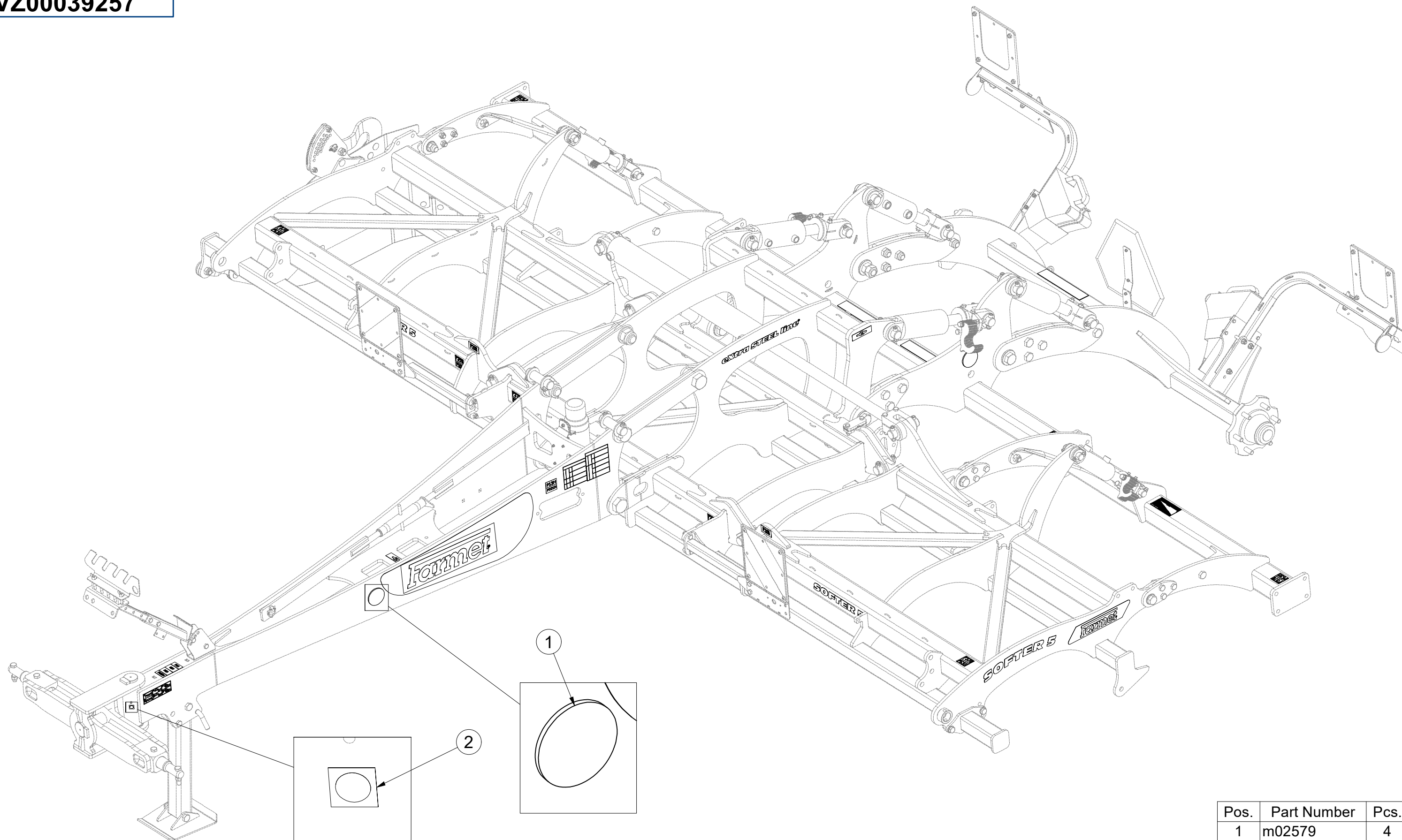

Pos.	Part Number	Pcs.
1	m02579	4
2	m03320	1

☉ SAMOLEPKY STROJE

☉ AUFKLEBER MASCHINEN

☉ VOITURE MACHINES

☉ STICKERS MACHINES

☉ СТИКЕРЫ МАШИНЫ

☉ NAKLEJKI MASZYNY



m24190

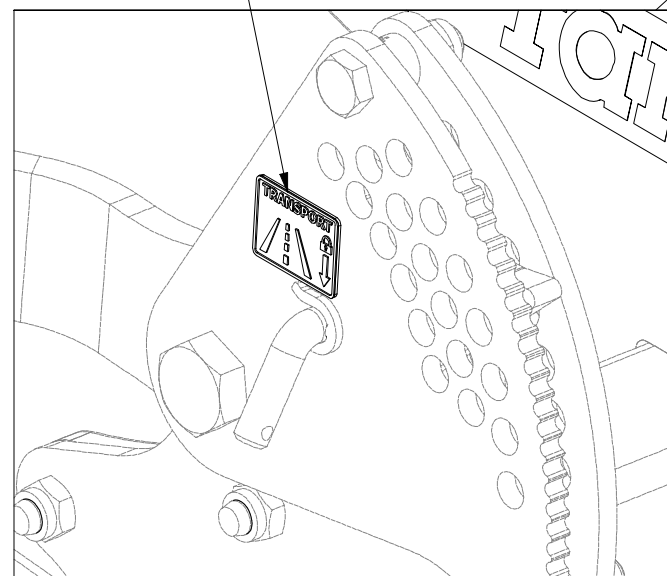
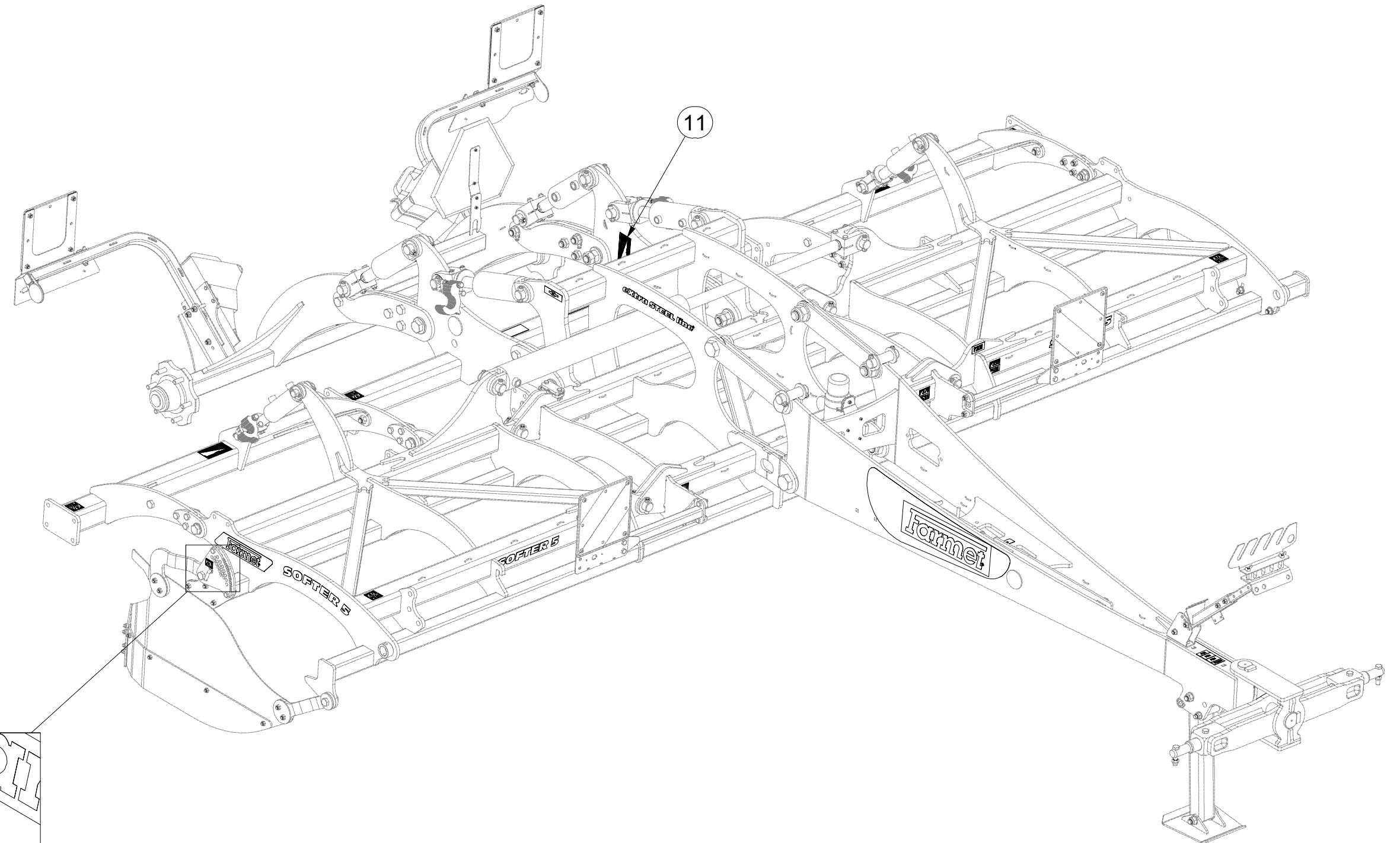

Pos.	Part Number	Pcs.
11	m24170	3
12	m22872	1

(CZ) SAMOLEPKY STROJE
 (D) AUFKLEBER MASCHINEN
 (F) VOITURE MACHINES

(GB) STICKERS MACHINES
 (RU) СТИКЕРЫ МАШИНЫ
 (PL) NAKLEJKI MASZYNY



m24190

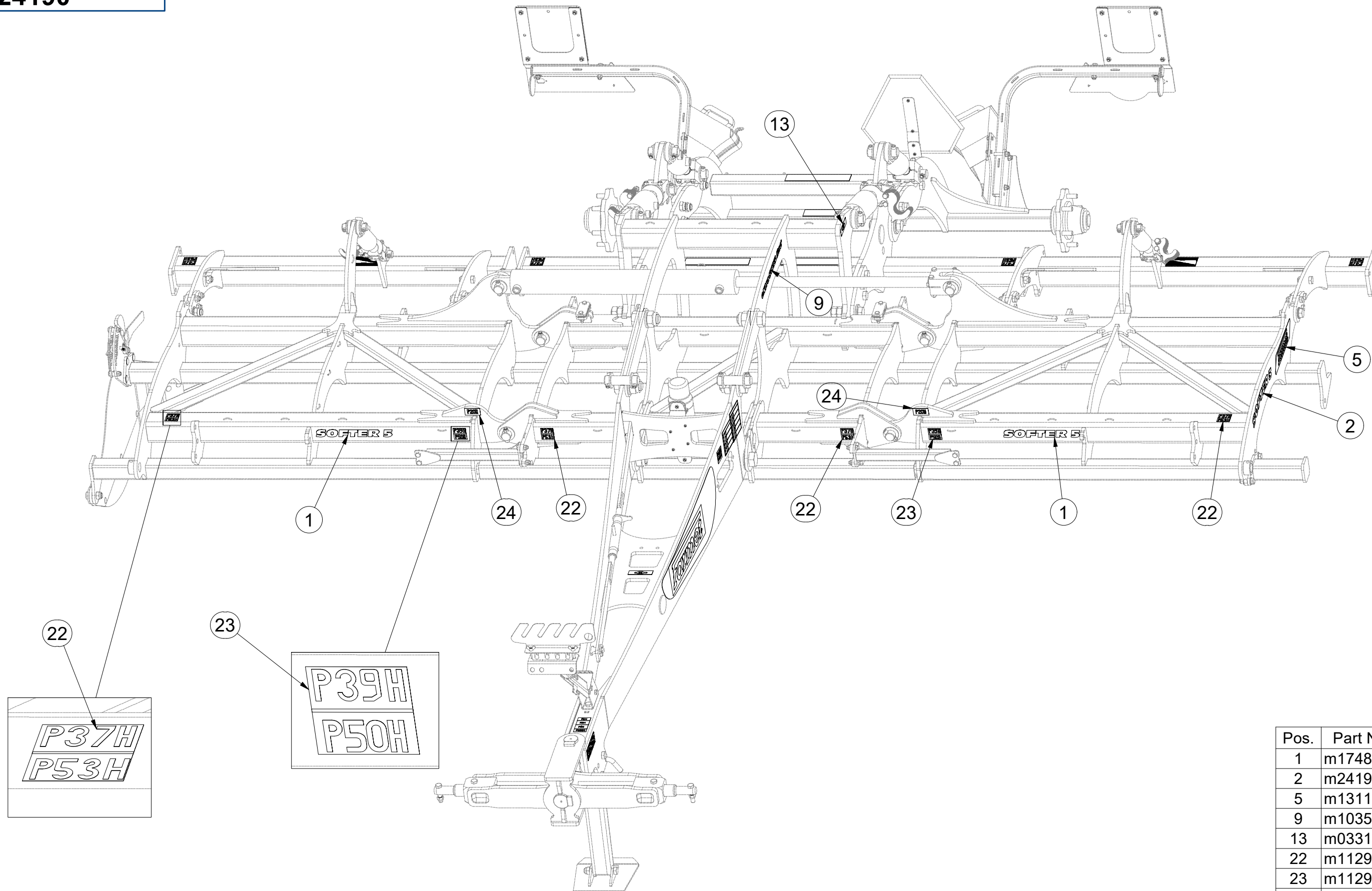

Pos.	Part Number	Pcs.
1	m17487	5
2	m24191	2
5	m13117	2
9	m10353	2
13	m03316	3
22	m11297	8
23	m11296	2
24	m04368	4

☉ SAMOLEPKY STROJE

☉ AUFKLEBER MASCHINEN

☉ VOITURE MACHINES

☉ STICKERS MACHINES

☉ СТИКЕРЫ МАШИНЫ

☉ NAKLEJKI MASZYN



m24190

Pos.	Part Number	Pcs.
1	m17487	5
2	m24191	2
5	m13117	2
6	m13116	3
9	m10353	2
11	m24170	3
13	m03316	3
14	m03512	2
15	m11147	4
22	m11297	8
24	m04368	4

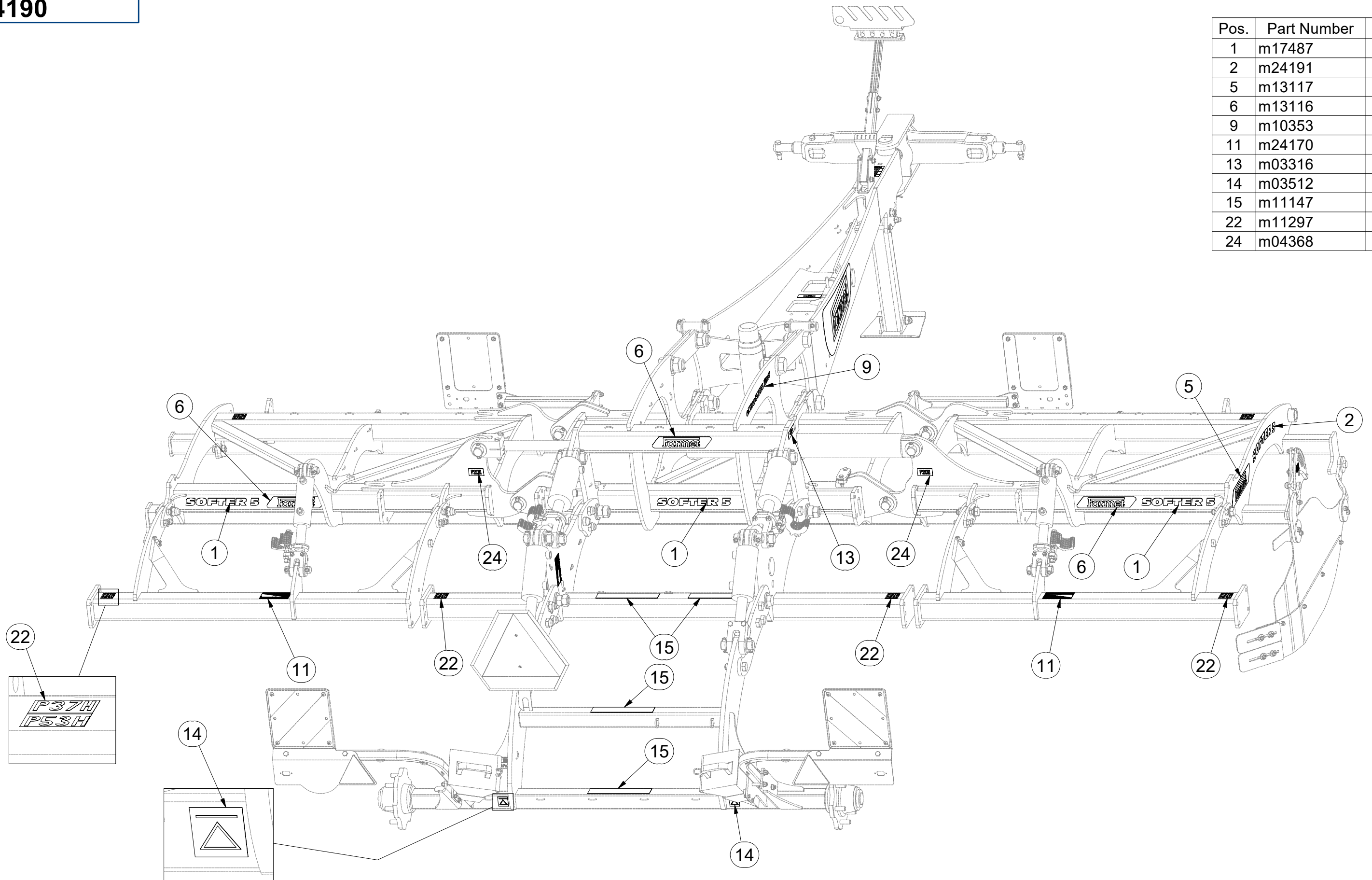

☉ SAMOLEPKY STROJE

☉ AUFKLEBER MASCHINEN

☉ VOITURE MACHINES

☉ STICKERS MACHINES

☉ СТИКЕРЫ МАШИНЫ

☉ NAKLEJKI MASZYNY



m24190

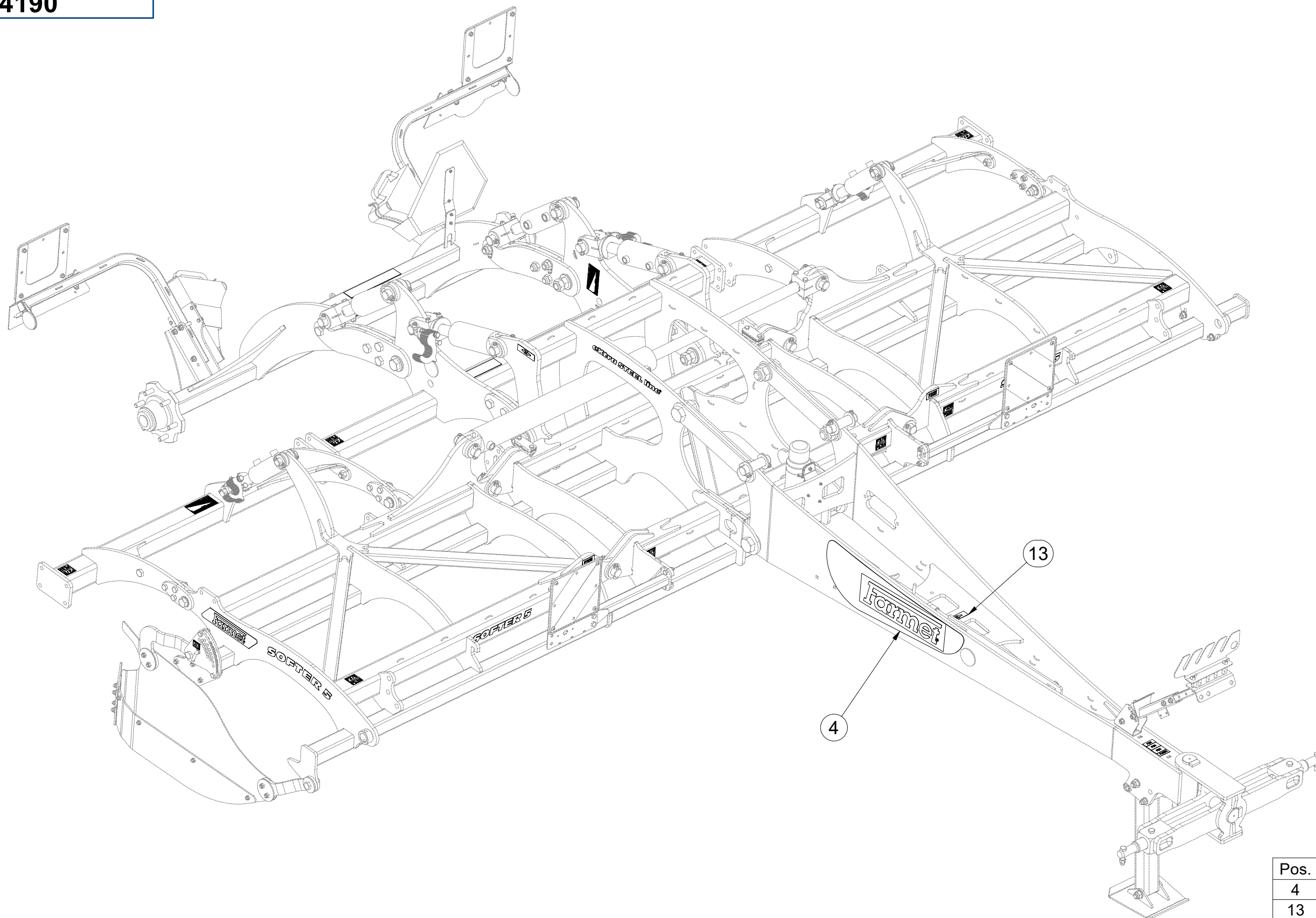

Pos.	Part Number	Pcs.
4	m13102	1
13	m03316	3

CZ SAMOLEPKY STROJE
 D AUFKLEBER MASCHINEN
 F VOITURE MACHINES

GB STICKERS MACHINES
 RU СТИКЕРЫ МАШИНЫ
 PL NAKLEJKI MASZYNY



m24190

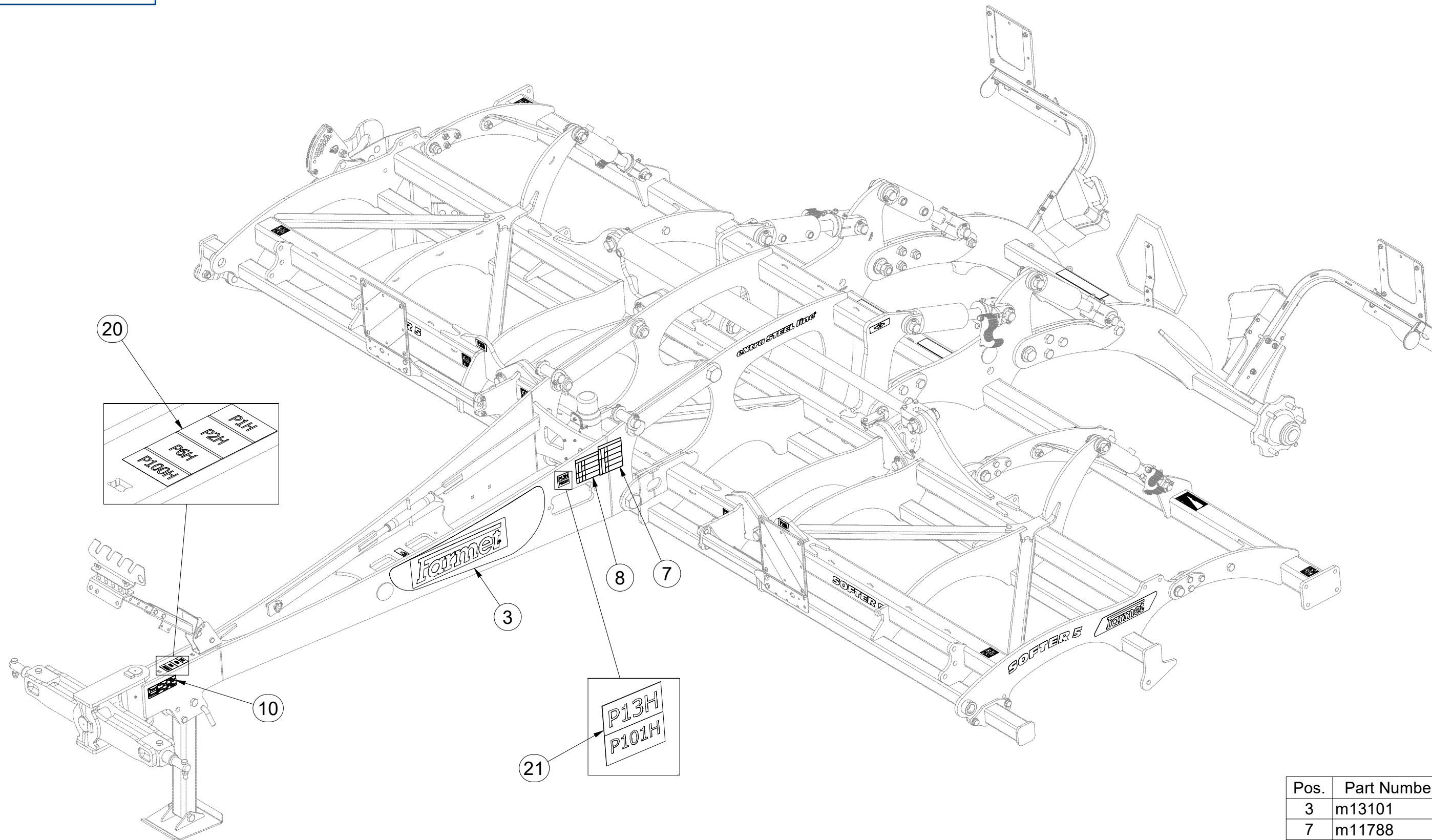

Pos.	Part Number	Pcs.
3	m13101	1
7	m11788	1
8	m11787	1
10	m21969	1
20	m11295	1
21	m11299	1

4025230

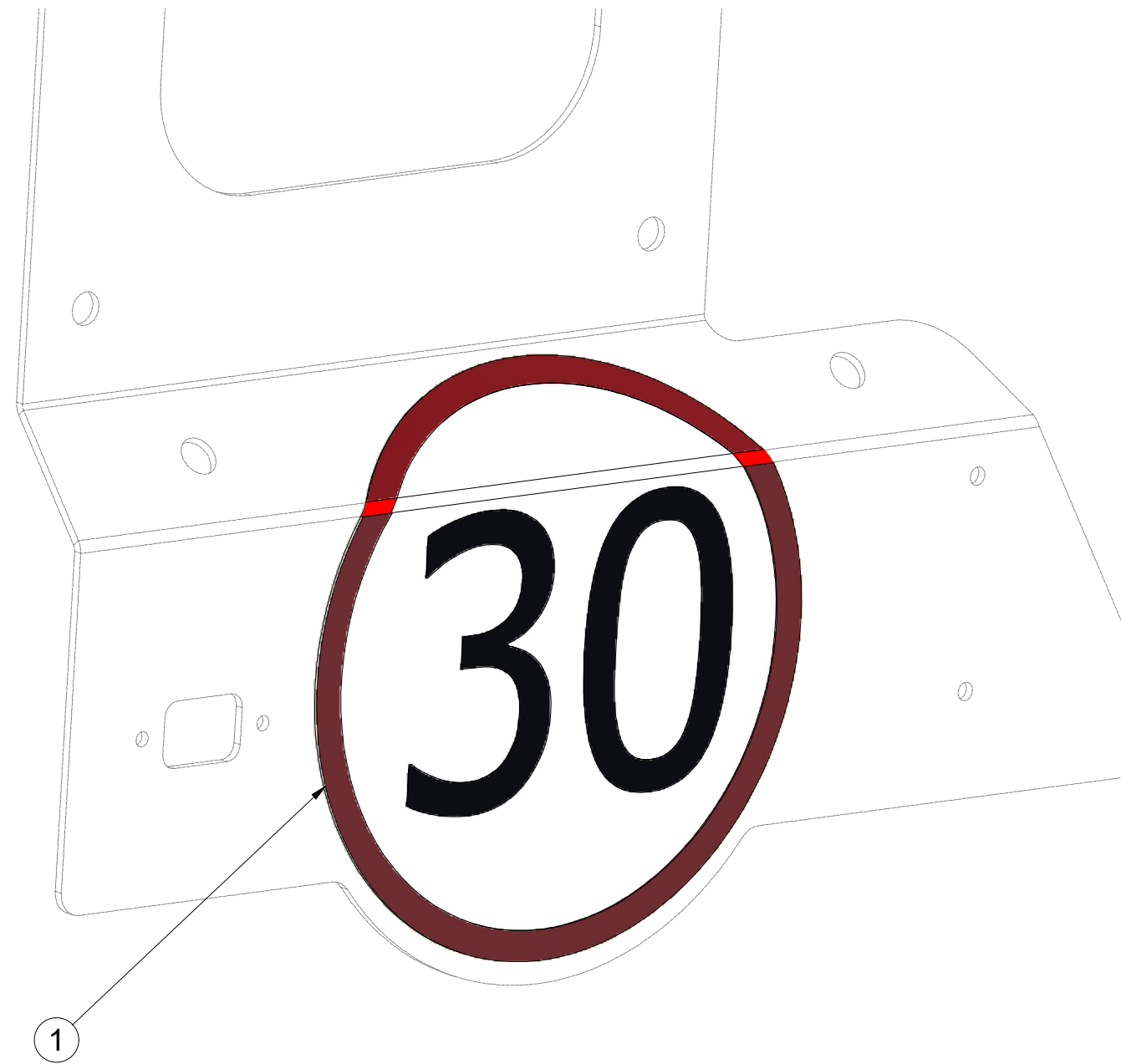

Pos.	Part Number	Pcs.
1	m19161	1

Ⓒ SVĚTELNÁ SADA

Ⓓ LEUCHTENSATZ

Ⓕ KIT LUMINEUX

Ⓖ LIGHTING SET

Ⓡ ОСВЕТИТЕЛЬНЫЙ КОМПЛЕКТ

Ⓟ ZESTAW OŚWIETLENIA



3012500

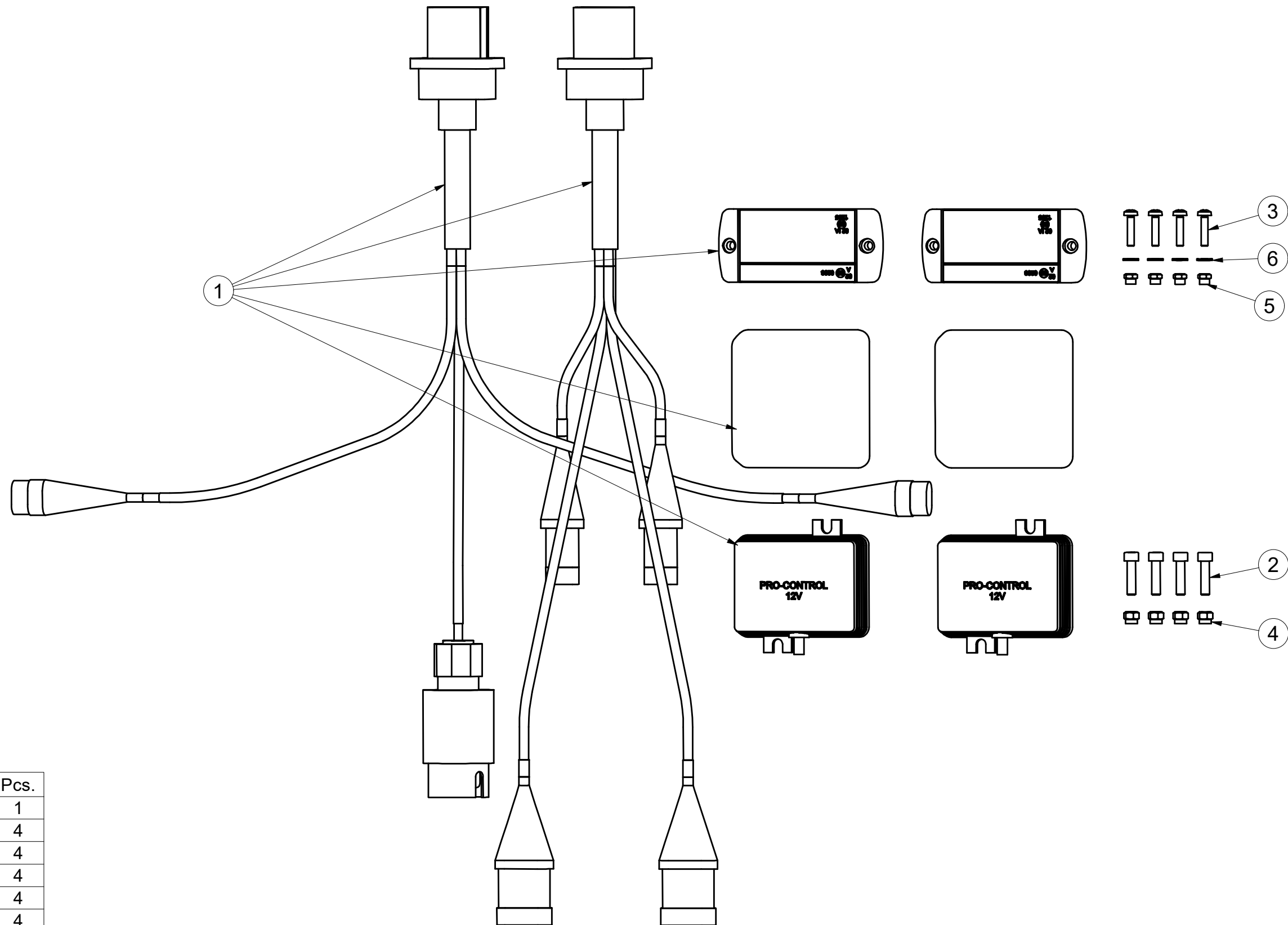

Pos.	Part Number	Pcs.
1	m19050	1
2	m10591	4
3	m15790	4
4	m06236	4
5	m05562	4
6	m05597	4

Ⓒ SVĚTELNÁ SADA

Ⓓ LEUCHTENSATZ

Ⓕ KIT LUMINEUX

Ⓖ LIGHTING SET

Ⓡ ОСВЕТИТЕЛЬНЫЙ КОМПЛЕКТ

Ⓟ ZESTAW OŚWIETLENIA



m19050

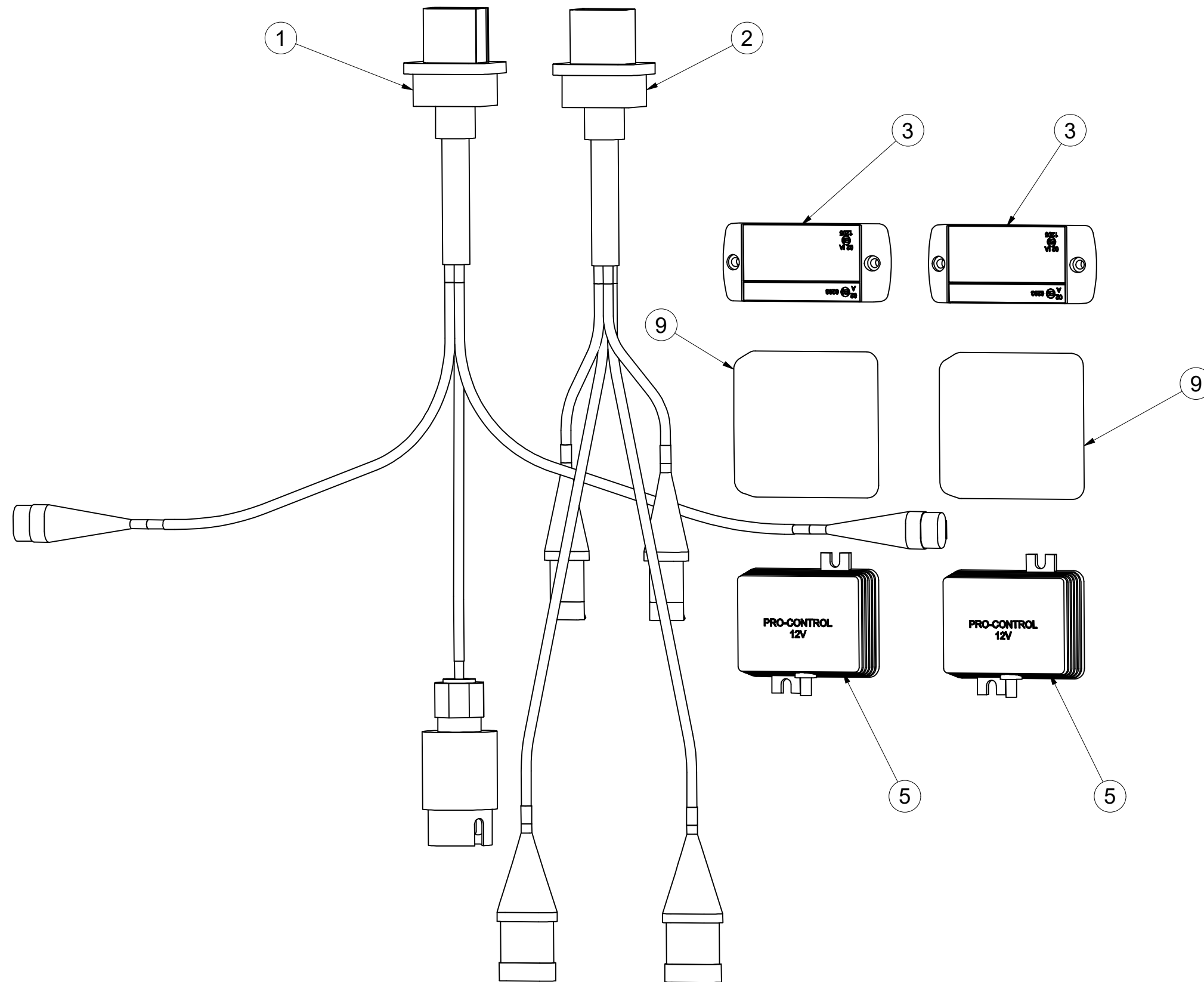

Pos.	Part Number	Pcs.
1	m14779	1
2	m14778	1
3	m14776	2
5	m14777	2
9	m19044	2

- Ⓒ UTAHOVACÍ MOMENTY ŠROUBŮ
 Ⓓ ANZUGMOMENTE VON SCHRAUBEN
 Ⓕ COUPLES DE SERRAGE DES VIS

- Ⓒ SCREW TIGHTENING TORQUE
 Ⓓ МОМЕНТЫ ЗАЖАТИЯ БОЛТОВ
 Ⓕ MOMENTY DOKRĘCANIA ŚRUB



P		5.8	8.8	10.9	12.9	Z	
D	R	Mu	Mu	Mu	Mu	DIN 7991	ISO 10642
mm	mm	Nm	Nm	Nm	Nm	Nm	Nm
M6	1	6	9	13	15	7,2	7,9
M8	1,25	14	22	32	38	17	19
M10	1,5	29	44	64	75	35	38
M12	1,75	49	76	111	130	58	65
M14	2	79	120	176	206	93	100
M16	2	123	188	276	323	144	158
M18	2,5	169	257	378	443	-	220
M20	2,5	239	365	536	628	-	310
M22	2,5	329	529	738	864	-	420
M24	3	413	629	924	1082	-	530
M27	3	613	934	1372	1606	-	-
M30	3,5	832	1267	1862	2179	-	-
M33	3,5	1130	1723	2530	2961	-	-
M36	4	1451	2210	3246	3799	-	-
M39	4	1885	2872	4217	4936	-	-
M42	4,5	2322	3538	5196	6080	-	-
M45	4,5	2909	4433	6511	7619	-	-
M48	5	3513	535	7862	9200	-	-
M52	5	4524	6895	10123	11849	-	-
M56	5,5	5636	8589	12614	14761	-	-

- Mu - Ⓒ UTAHOVACÍ MOMENT
 Ⓓ ANZUGMOMENTE
 Ⓕ COUPLE DE SERRAGE
 Ⓒ TIGHTENING TORQUE
 Ⓓ МОМЕНТ ЗАЖАТИЯ
 Ⓕ MOMENT DOKRĘCANIA
- D - Ⓒ JMENOVITÝ PRŮMĚR
 Ⓓ NENNDURCHMESSER
 Ⓕ DIAMETRE NOMINAL
 Ⓒ NOMINAL DIAMETER
 Ⓓ НОМИНАЛЬНЫЙ ДИАМЕТР
 Ⓕ ŚREDNICA NOMINALNA
- R - Ⓒ ROZTEČ ZÁVITU - STOUPÁNÍ
 Ⓓ GEWINDESTEIGUNG
 Ⓕ PAS DE FILET - PAS
 Ⓒ SCREW PITCH – LEAD
 Ⓓ ШАГ РЕЗЬБЫ
 Ⓕ ROZSTAW GWINTU - SKOKI
- P - Ⓒ PEVNOST
 Ⓓ FESTIGKEIT
 Ⓕ RÉSISTANCE
 Ⓒ STRENGTH
 Ⓓ ПРОЧНОСТЬ
 Ⓕ WYTRZYMA OŚĆ
- Z - Ⓒ ZÁPUSTNÉ ŠROUBY
 Ⓓ SENKKOPFSCHRAUBEN
 Ⓕ VIS A TETE FRAISEE
 Ⓒ COUNTERSUNK SCREWS
 Ⓓ БОЛТЫ С УТОПЛЕННОЙ ГОЛОВКОЙ
 Ⓕ ŚRUBY Z ŁBEM STOŻKOWYM PŁASKIM

- Ⓒ Hodnoty momentů jsou poníženy o -10% oproti tabulkovým hodnotám. Šroubové spoje utahujte dle vyznačeného utahovacího momentu v dokumentaci. Pokud není utahovací moment v dokumentaci vyznačen, utahujte dle obecné tabulky. Pokud je v dokumentaci definován spoj šroubu a matice o různých pevnostech, vždy utahujte na moment komponenty nižší.
- Ⓓ Die Werte der Anzugsmomente sind um 10 % gegenüber den Tabellenwerten verringert. Ziehen Sie die Schraubverbindungen gemäß dem in der Dokumentation festgeschriebenen Anzugsmoment an. Sofern das Anzugsmoment nicht in der Dokumentation aufgeführt ist, ziehen Sie sie gemäß der allgemeinen Tabelle an. Wenn in der Dokumentation eine Verbindung von Schraube und Mutter mit verschiedene Festigkeiten definiert ist, wird immer mit dem Moment des Bauteils mit der geringeren Festigkeit angezogen.
- Ⓕ Les valeurs des couples de serrage sont baissées de 10% par rapport aux valeurs de tableau. Serrez les raccords à vis selon le couple de serrage indiqué dans les documents. Si le couple de serrage n'est pas indiqué dans les documents, serrez selon le tableau général. Si les documents définissent un assemblage par boulon de diverses résistances, serrez toujours au moment de la composante avec résistance inférieure.
- Ⓒ The torque values are reduced by 10% compared to the table values. Tighten the screw joints according to the tightening torque stated in the documentation. If the tightening torque is not stated in the documentation, tighten according to the general table. If there is a joint with a screw and a nut at different strengths in the documentation, always tighten to the torque of the component with lower strength.
- Ⓓ Значения моментов затяжки уменьшены на 10% по сравнению с данными в таблице. Резьбовые соединения зажимайте с установленным в документации моментом зажатия. Если в документации не указан момент зажатия, то зажимайте по действующей в общем таблице. Если в документации установлено соединение из болта и гайки различной прочности, всегда зажимайте с моментом для компонента с меньшей прочностью.
- Ⓕ Wartości momentów dokręcania są obniżone o 10% w stosunku do wartości z tabeli. Połączenia śrubowe należy dokręcać zgodnie z momentem obrotowym w dokumentacji. Jeśli w dokumentacji nie ma podanego momentu obrotowego, należy dokręcać zgodnie z ogólną tabelą. Jeśli w dokumentacji zdefiniowane jest połączenie ze śrubą nakrętką różnych wytrzymałościach, zawsze należy dokręcać zachowując moment dokręcania komponentu z niższą wytrzymałością.

- Ⓒ UTAHOVACÍ MOMENTY ŠROUBŮ
 Ⓓ ANZUGMOMENTE VON SCHRAUBEN
 Ⓕ COUPLES DE SERRAGE DES VIS

- Ⓖ SCREW TIGHTENING TORQUE
 Ⓡ MOMENTЫ ЗАЖАТИЯ БОЛТОВ
 Ⓟ MOMENTY DOKRĘCANIA ŚRUB



- Ⓒ **OBECNÝ PŘEDPIS UTAHOVÁNÍ ZAJIŠTĚNÍ ČEPOVÝCH SPOJŮ:**
 Ⓓ **ALLGEMEINE VORSCHRIFT FÜR DAS ANZIEHEN VON BOLZENVERBINDUNGEN:**
 Ⓕ **CONSIGNE GENERALE POUR LE SERRAGE DES ARTICULATIONS CYLINDRIQUES:**
 Ⓖ **GENERAL INSTRUCTION FOR TIGHTENING THE SECURING OF PIN JOINTS:**
 Ⓡ **ОБЩЕЕ ОПИСАНИЕ ЗАЖАТИЯ ПРЕДОХРАНЕНИЯ СОЕДИНЕНИЙ ПАЛЬЦАМИ:**
 Ⓟ **OGÓLNE ZASADY DOKRĘCANIA ZABEZPIECZENIA POŁĄCZEŃ CZOPEM:**



X

M8, M10, M12

M14

M

09-15Nm

15-25Nm

- X - Ⓒ ROZMĚR ŠROUBU
 Ⓓ SCHRAUBENGRÖSSE
 Ⓕ DIMENSIONS DE LA VIS

- Ⓖ BOLT DIMENSION
 Ⓡ РАЗМЕР БОЛТА
 Ⓟ ROZMIAR ŚRUBY

- M - Ⓒ ORIENTAČNÍ MOMENT
 Ⓓ ANZUGSMOMENT
 Ⓕ COUPLE D'ORIENTATION

- Ⓖ ORIENTATION TORQUE
 Ⓡ ОПИЕНТАЦИОННЫЙ МОМЕНТ
 Ⓟ ORIENTACYJNY MOMENT

- Ⓒ Tyto spoje není nutné ověřovat kontrolou momentovým klíčem = stačí vizuálně kontrolovat sešroubování.
 Ⓓ Diese Verbindungen müssen nicht mit einem Drehmomentschlüssel überprüft werden = es genügt, die Verschraubung visuell zu kontrollieren.
 Ⓕ Il n'est pas nécessaire de contrôler le serrage à l'aide d'une clé dynamométrique = un contrôle visuel de l'assemblage suffit.
 Ⓖ These joints do not have to be verified by checking with a torque wrench = visual inspection of bolting is sufficient.
 Ⓡ Эти соединения не нужно контролировать динамометрическим ключом = достаточно визуально проверять прикручивание.
 Ⓟ Nie trzeba sprawdzać tych połączeń kluczem dynamometrycznym = wystarczy wizualnie skontrolować dokręcenie.