

The effective technology

Farmet[®]

ⒸZ KATALOG NÁHRADNÍCH DÍLŮ ⒸB CATALOGUE OF SPARE PARTS ⒸD ERSATZTEILLISTE
ⒸRU КАТАЛОГ ЗАПАСНЫХ ЧАСТЕЙ ⒸF CATALOGUE DES PIÈCES DE RECHANGE ⒸPL KATALOG CZĘŚCI ZAMIENNYCH

FANTOM FX 300 N

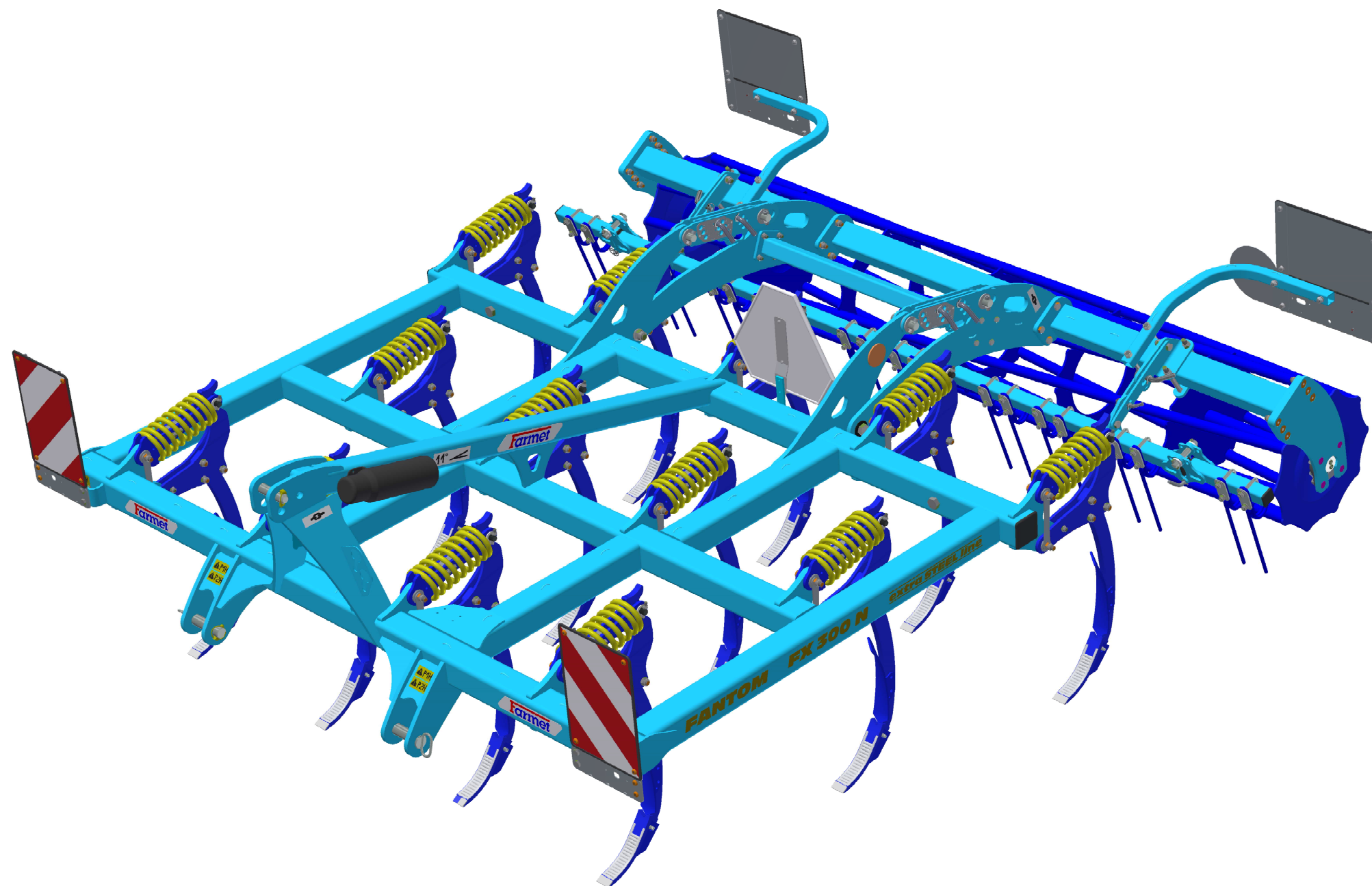

ⒸZ Platnost pro vrcholové | výrobní číslo stroje ⒸB Validity for the top | serial number of the machine
ⒸD Gültigkeit für die Haupt- | Herstellungsnummer der Maschine ⒸRU Действительно для главного | заводского номера машины
ⒸF Validité du numéro de référence | de série de la machine ⒸPL Obowiązuje dla numeru głównego | seryjnego maszyny

9313069 | 2019/1071

Farmet a. s.
Jiřinková 276
552 03 Česká Skalice, CZ

telefon: +420 491 450 111
fax: +420 491 450 136
GSM: +420 774 715 738

IČ: 46504931
DIČ: CZ46504931

web: www.farmet.cz
e-mail: farmet@farmet.cz

ⒸZ NAVIGACE STROJE

Ⓓ NAVIGATION DER MASCHINE

Ⓕ NAVIGATION DE LA MACHINE

ⒸB NAVIGATION OF THE MACHINE

ⒸU НАВИГАЦИЯ МАШИНЫ

ⒸL NAWIGACJA MASZYN

Farmet

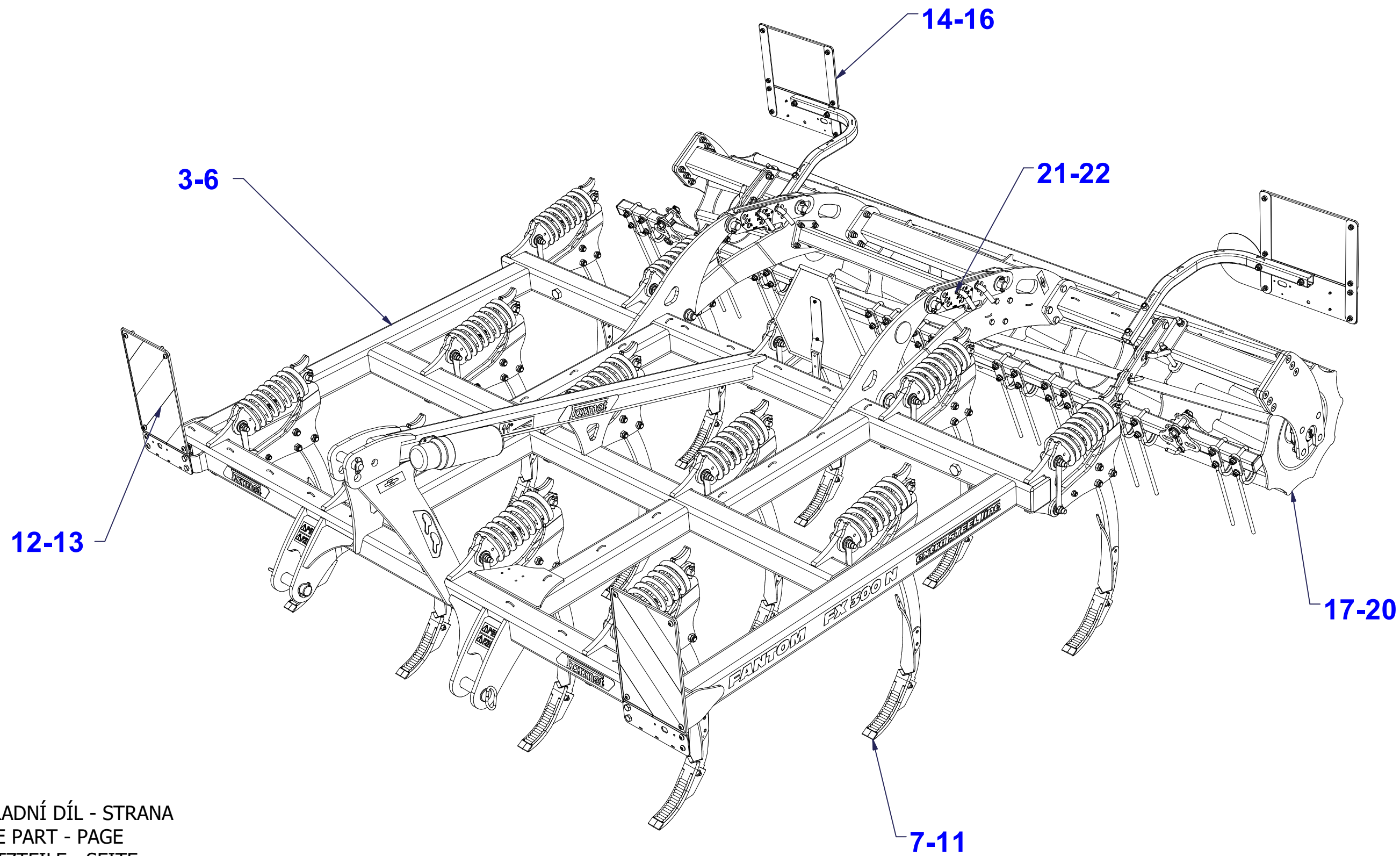

ⒸZ NÁHRADNÍ DÍL - STRANA

ⒸB SPARE PART - PAGE

Ⓓ ERSATZTEILE - SEITE

ⒸU ЗАПЧАСТЬ - СТРАНИЦА

Ⓕ PIÈCE DE RECHANGE - PAGE

ⒸL CZĘŚCI ZAMIENNE - STRONA

Ⓒ ZÁKLAD STROJE

Ⓓ UNTERBAU DER MASCHINE

Ⓕ BÂTI DE LA MACHINE

3012048

Ⓖ FOOTING OF THE MACHINE

Ⓡ ОСНОВАНИЕ МАШИНЫ

Ⓟ PODSTAWA MASZyny

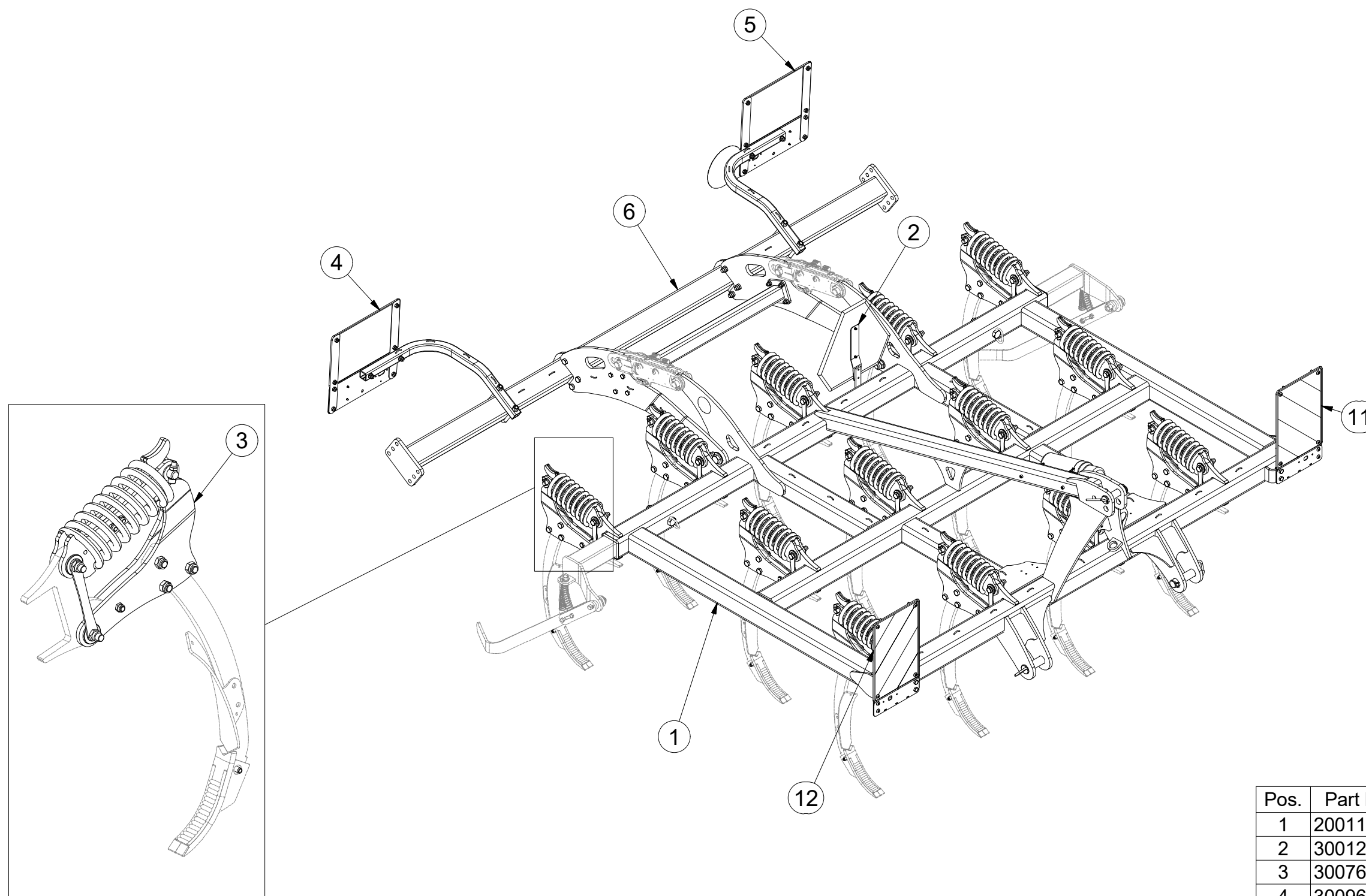

Pos.	Part Number	Pcs.
1	2001176	1
2	3001210	1
3	3007640	13
4	3009685	1
5	3009686	1
6	3009751	1
11	4019075	1
12	4019076	1

☞ ZÁKLAD STROJE

☞ UNTERBAU DER MASCHINE

☞ BÂTI DE LA MACHINE

☞ FOOTING OF THE MACHINE

☞ ОСНОВАНИЕ МАШИНЫ

☞ PODSTAWA MASZYNY



3012048

Pos.	Part Number	Pcs.
7	4006044	1
8	4009505	2
11	4019075	1
12	4019076	1
30	m04039	4
33	m14457	2
34	m05340	2
40	m04503	2
41	m04301	16
51	m01203	2
55	m10488	4
56	m16313	3
60	m15900	1

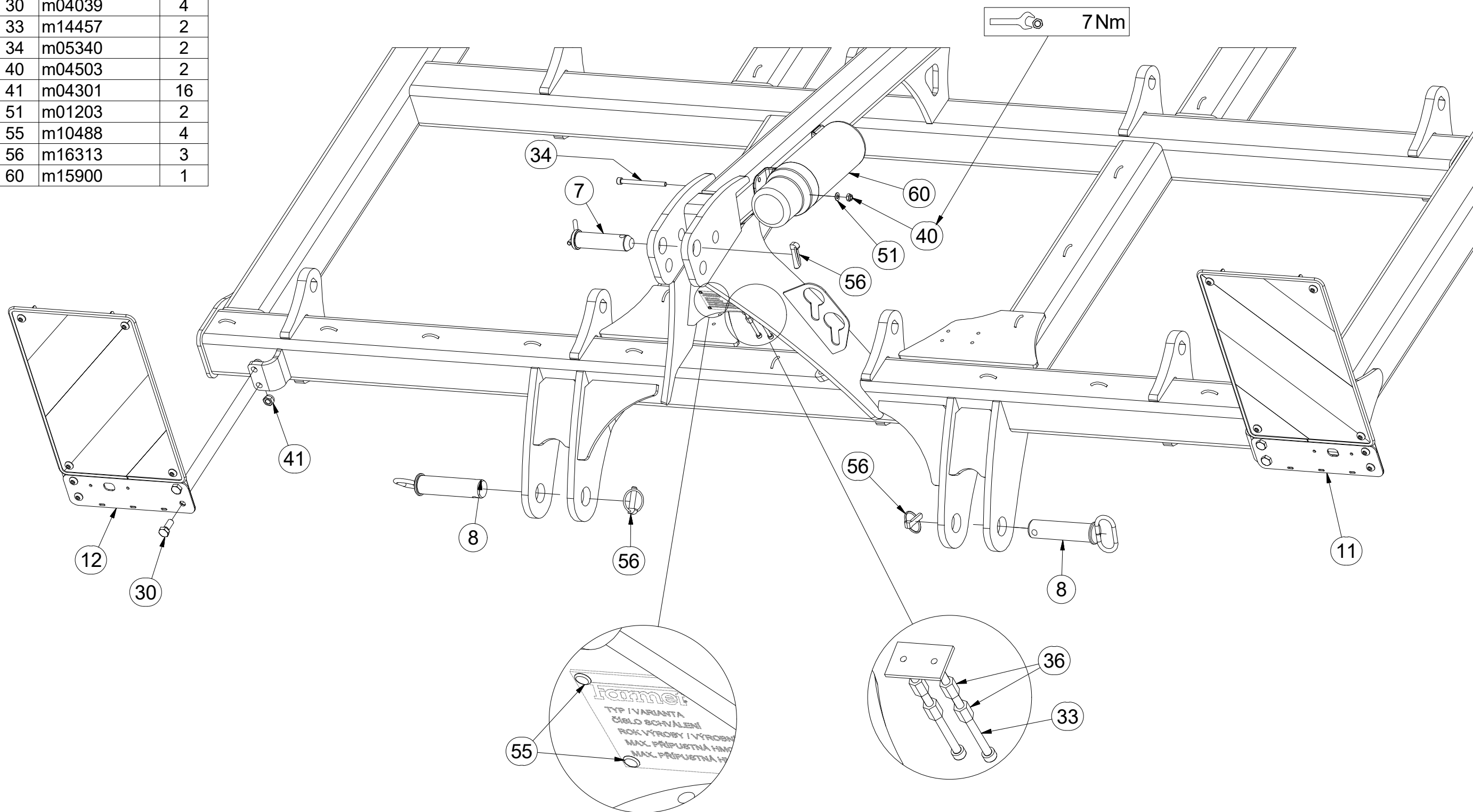

☉ ZÁKLAD STROJE

☐ UNTERBAU DER MASCHINE

☐ BÂTI DE LA MACHINE

☉ FOOTING OF THE MACHINE

☉ ОСНОВАНИЕ МАШИНЫ

☉ PODSTAWA MASZYNY



3012048

Pos.	Part Number	Pcs.
1	2001176	1
2	3001210	1
4	3009685	1
5	3009686	1
6	3009751	1
9	4018278	1
10	4018309	1
13	4019462	1
14	4019463	1
15	4024071	1
31	m06077	8
32	m14423	4
35	m11724	6
37	m06461	2
38	m13565	2
41	m04301	16
42	m13846	6
43	m12150	4
44	m13009	2
45	m07147	2
50	m01214	4
52	m03718	4
57	m02579	2
58	m05683	2
59	m10294	2
61	m16293	2
62	m16283	2
63	m16282	2

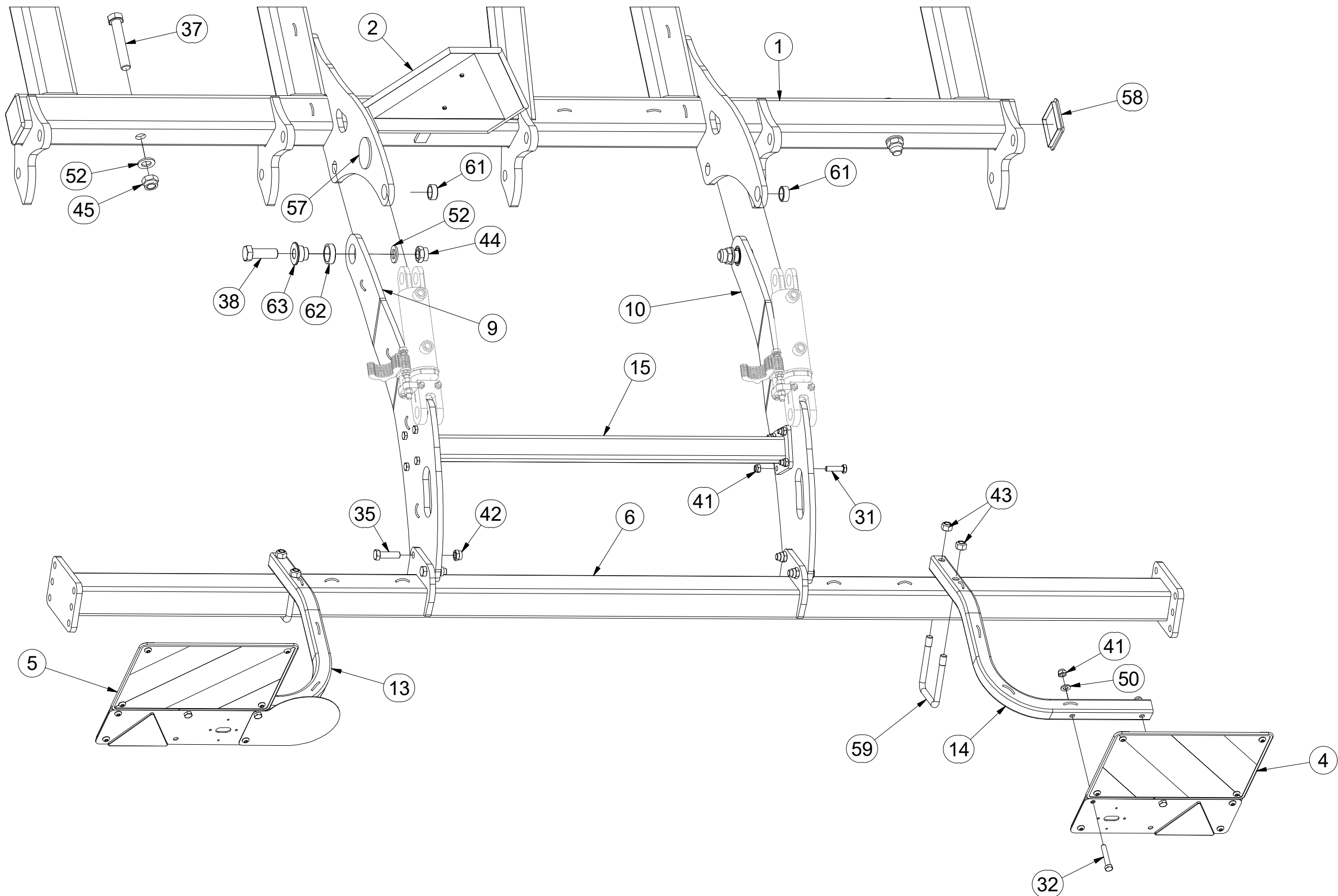

Ⓒ ZÁKLAD STROJE

Ⓓ UNTERBAU DER MASCHINE

Ⓕ BÂTI DE LA MACHINE

Ⓖ FOOTING OF THE MACHINE

Ⓡ ОСНОВАНИЕ МАШИНЫ

Ⓢ ПОДСТАВА МАСЗЫНЫ

Farmet

3012048

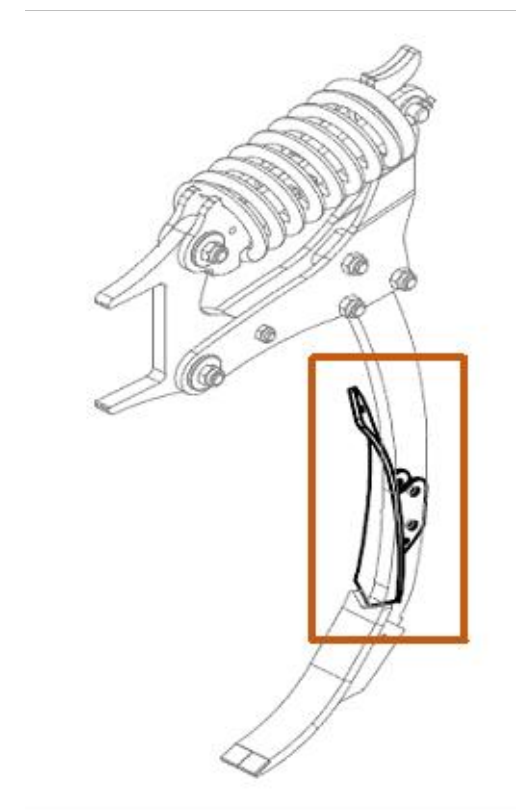
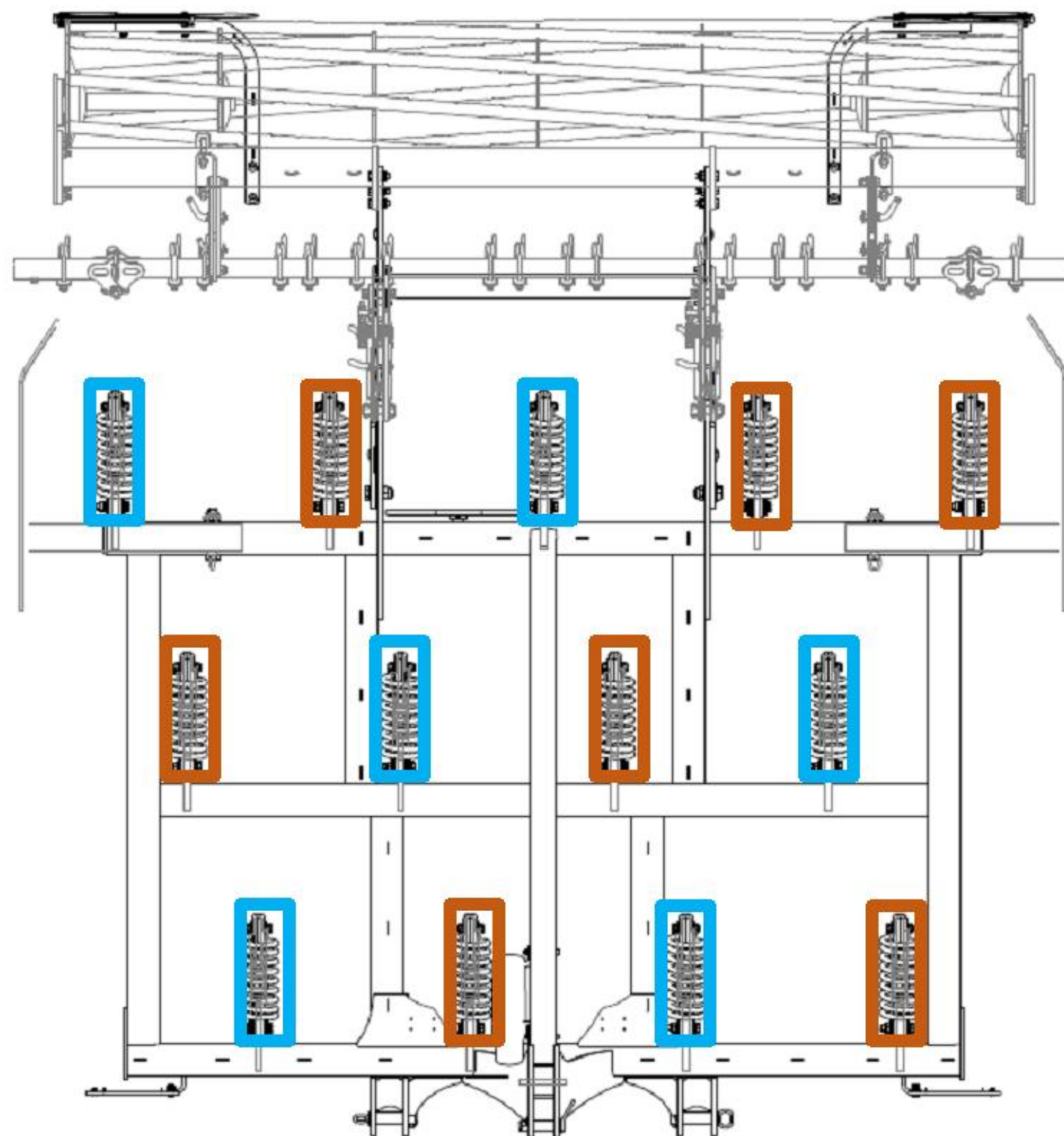

4019929
7ks

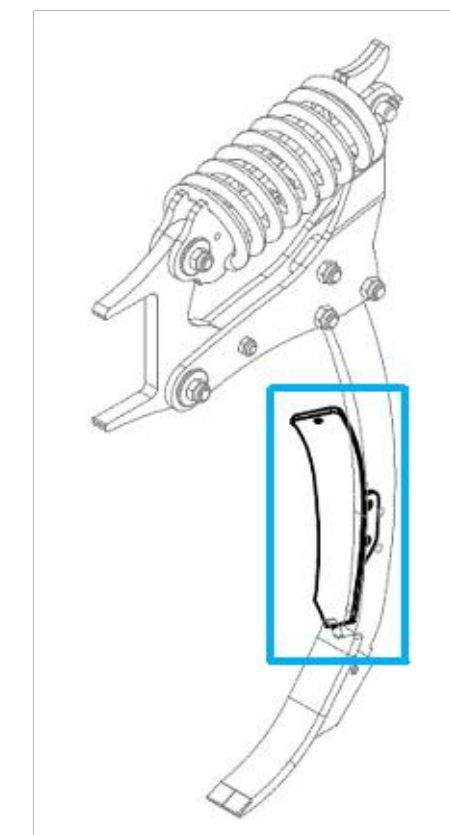

4019930
6ks

Ⓒ SLUPICE

Ⓓ PFLUGSÄULE

Ⓕ ÉTANÇON

3007640

Ⓖ TINE

Ⓡ СТОЙКА

Ⓢ SŁUPICA

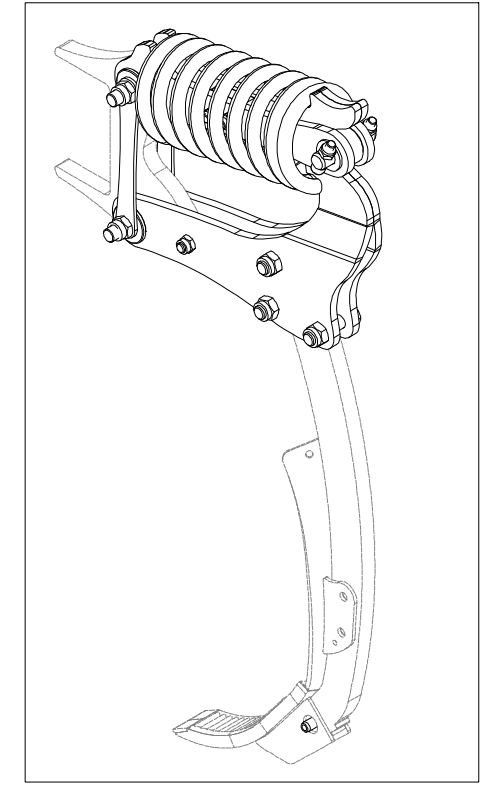
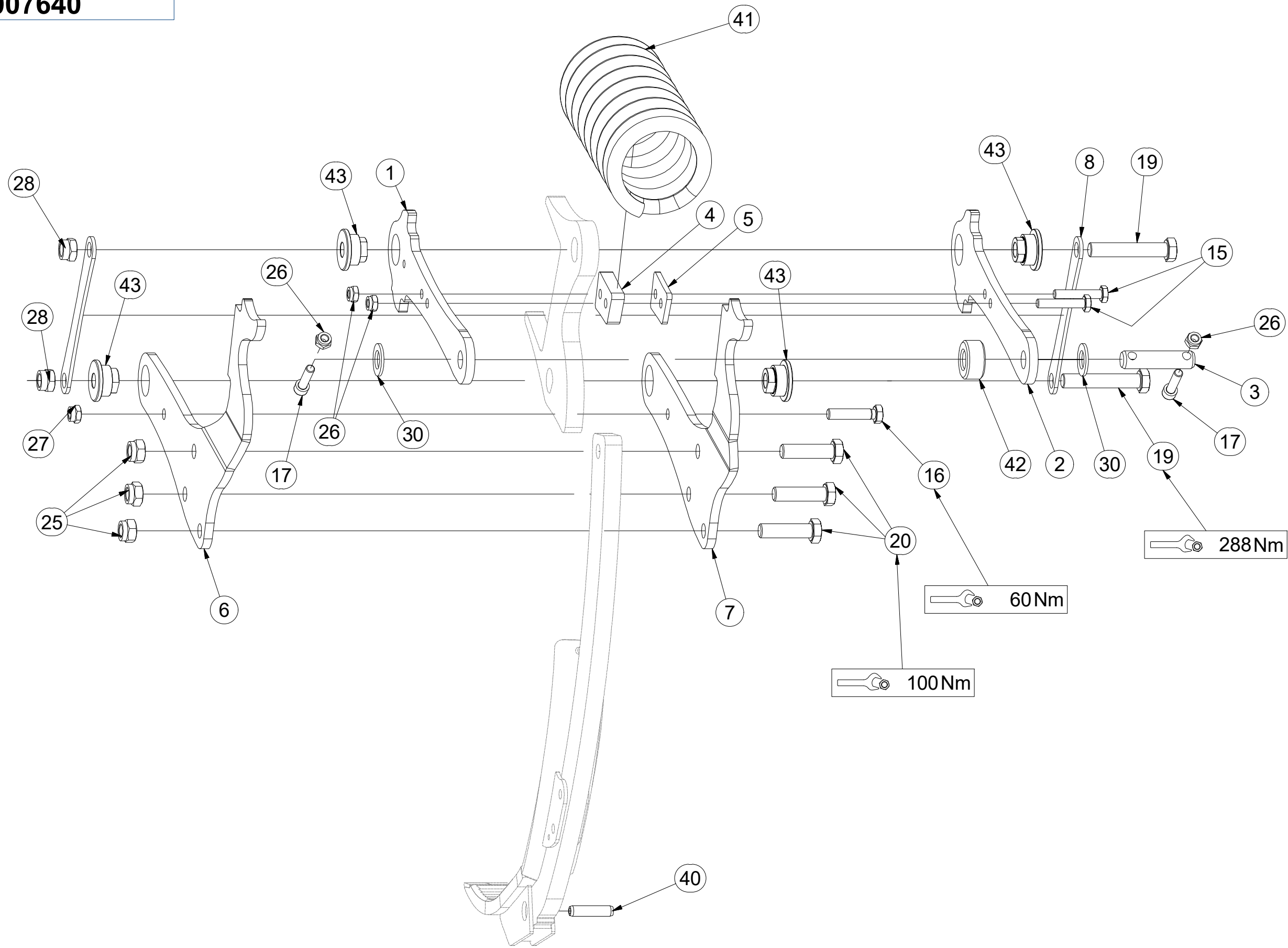

Pos.	Part Number	Pcs.
1	4014678	1
2	4014679	1
3	4014859	1
4	4018849	1
5	4018851	1
6	4022914	1
7	4022915	1
8	4023880	2
15	m06253	2
16	m09020	1
17	m14009	2
19	m18479	2
20	m14482	3
25	m03683	3
26	m03775	4
27	m06233	1
28	m18478	2
30	m14030	2
40	m05753	1
41	m14642	1
42	m14650	1
43	m18439	4

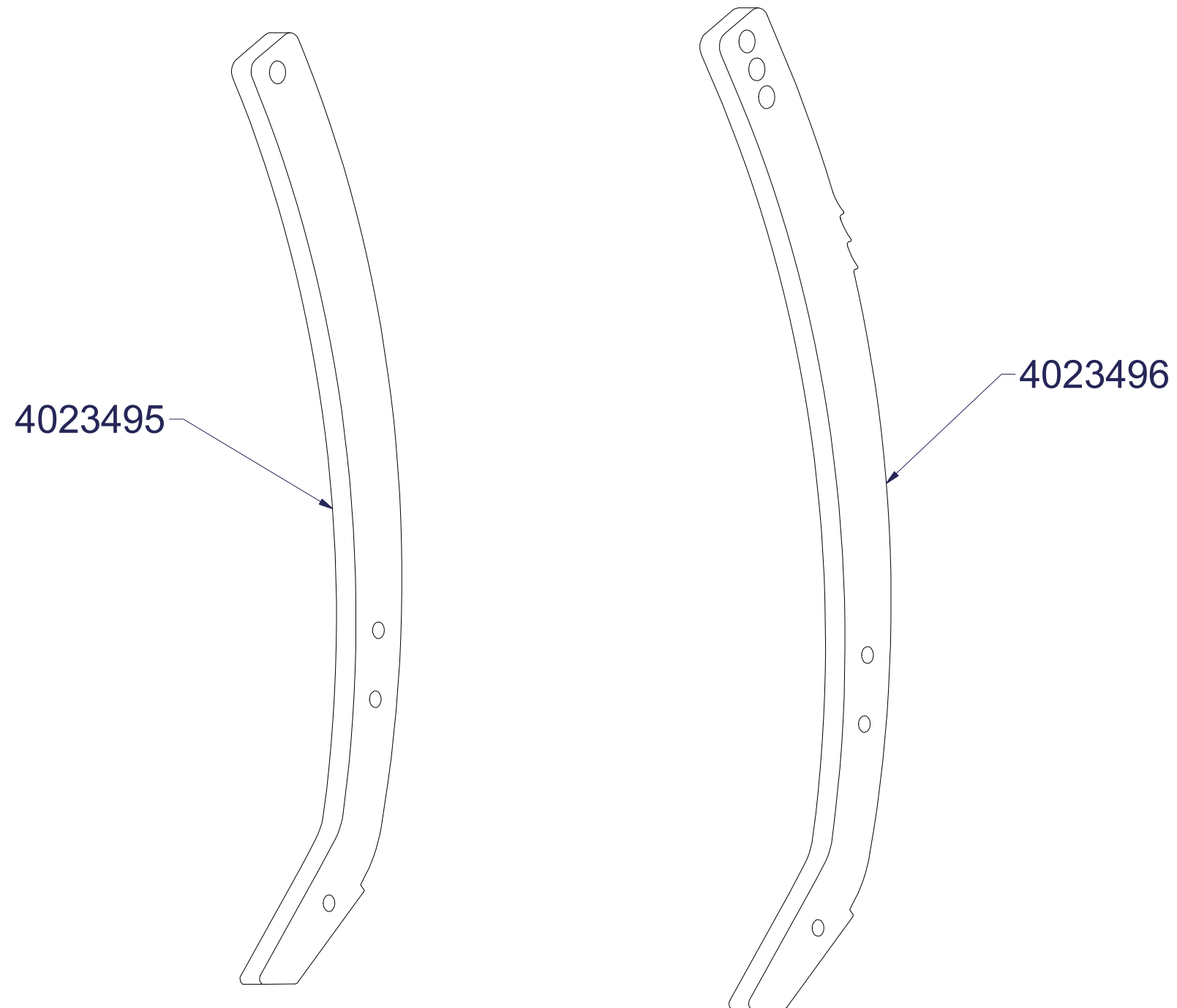

MACHINE	4023495 PCS.	4023496 PCS.
FX 300 N	13	0
FX350 N	16	0
FX 470 NS	22	0
FX 6,5	25	10
FX 8	33	10
FX 8,5	35	10
FX 10,5	45	12
FX 12,5	55	12

Ⓒ SADA DLÁTA
Ⓓ MEISSELSATZ
Ⓕ KIT DE CISEAU

Ⓖ SET OF CHISEL
Ⓡ КОМПЛЕКТ ЧИЗЕЛЕЙ
Ⓟ ZESTAW DŁUTA



4020539

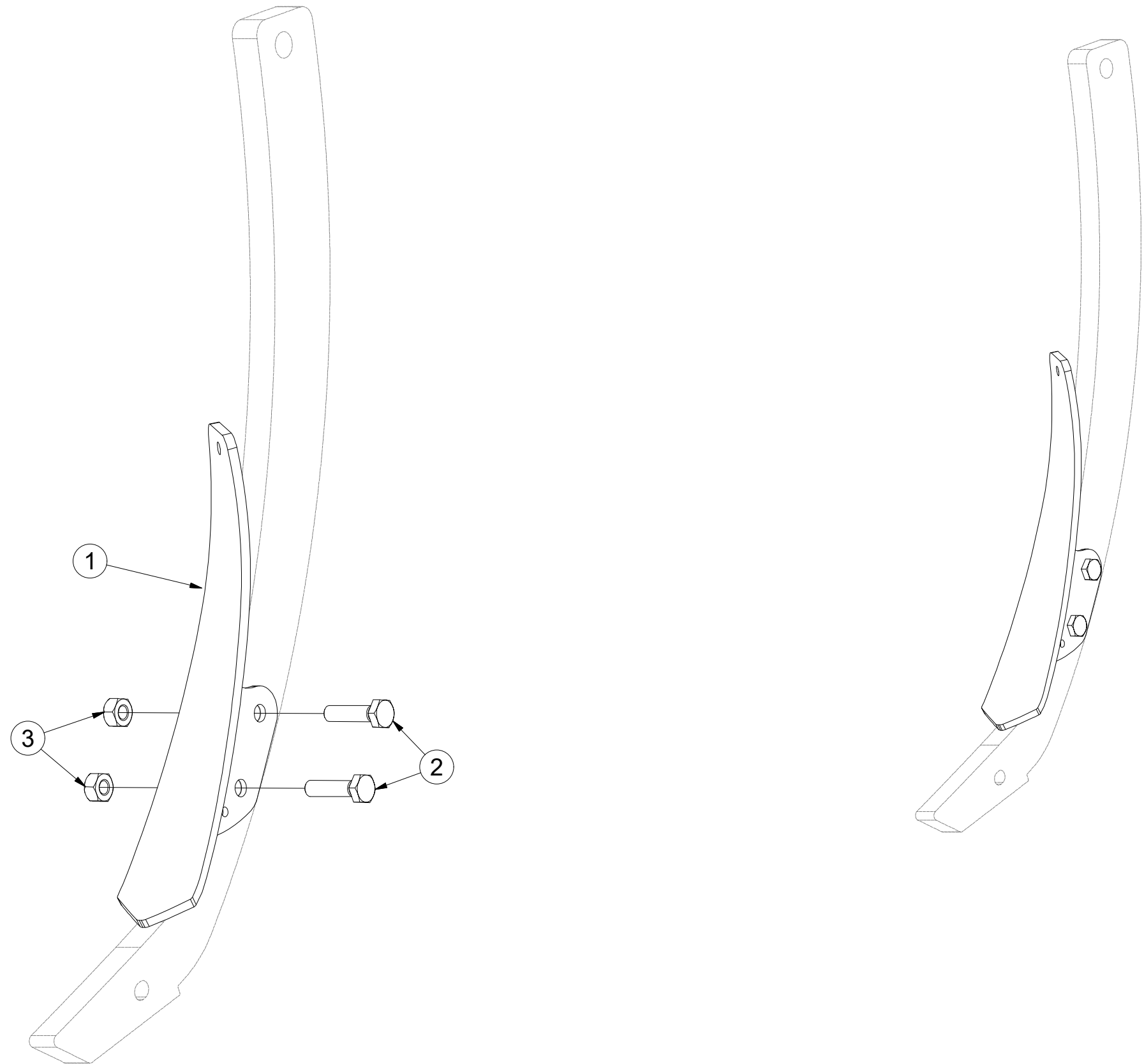

Pos.	Part Number	Pcs.
1	4019929	1
2	m01111	2
3	m08830	2

Ⓒ SADA DLÁTA
Ⓓ MEISSELSATZ
Ⓕ KIT DE CISEAU

Ⓖ SET OF CHISEL
Ⓔ КОМПЛЕКТ ЧИЗЕЛЕЙ
Ⓗ ZESTAW DŁUTA



4020540

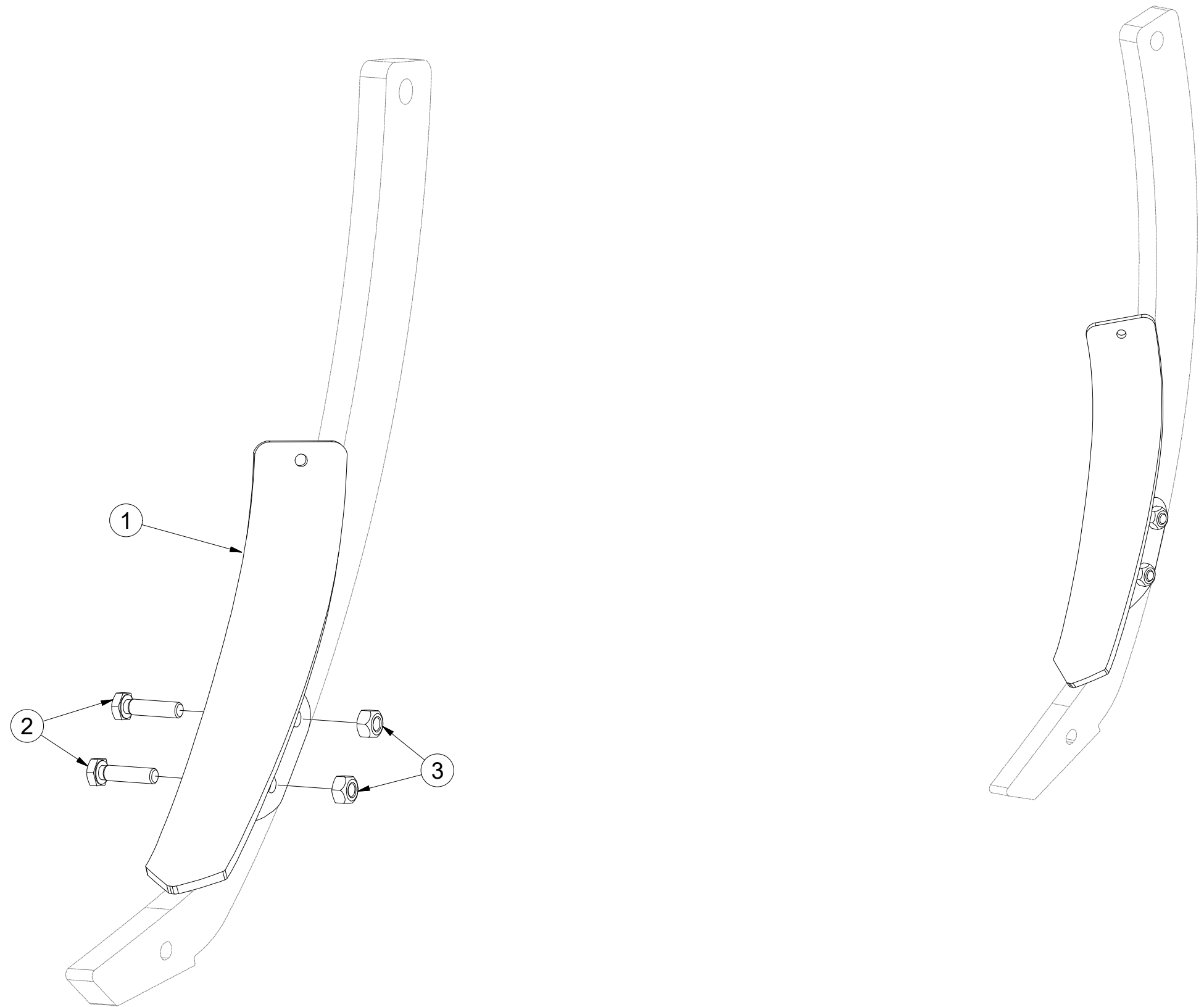

Pos.	Part Number	Pcs.
1	4019930	1
2	m01111	2
3	m08830	2

Ⓒ RADLICE / DLÁTO

Ⓓ SCHARE / MEISSEL

Ⓕ SOC / CISEAU

Ⓖ SHARE / CHISEL

Ⓡ ЛАПА / ЧИЗЕЛЬ

Ⓟ REDLICE / DŁUTO



4023476

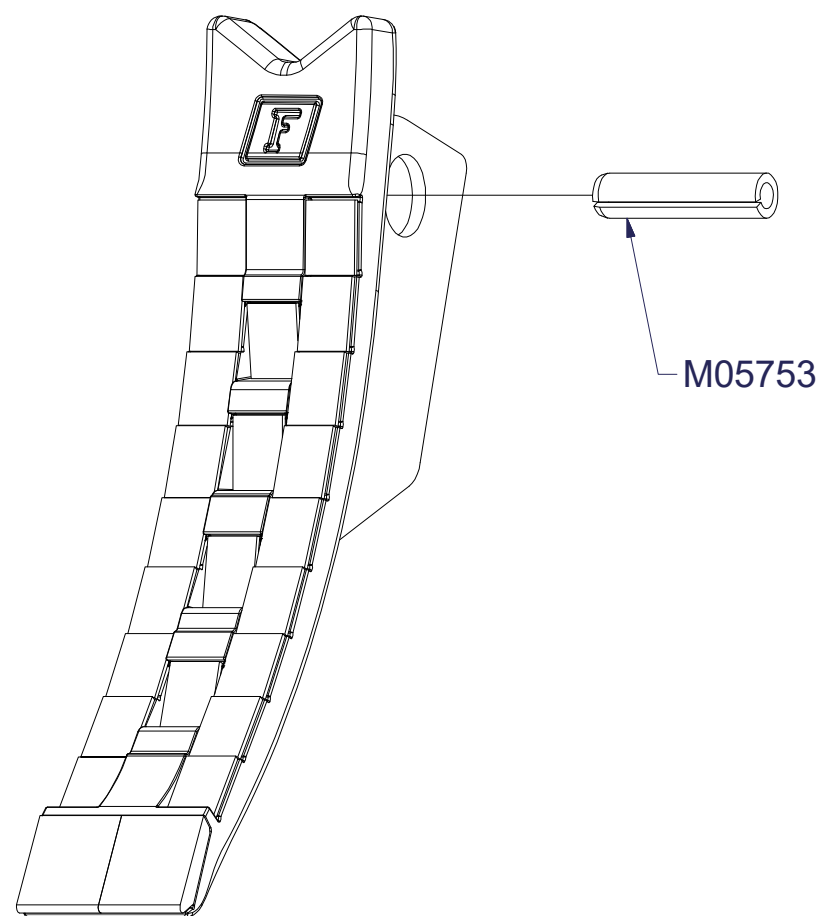

4022977

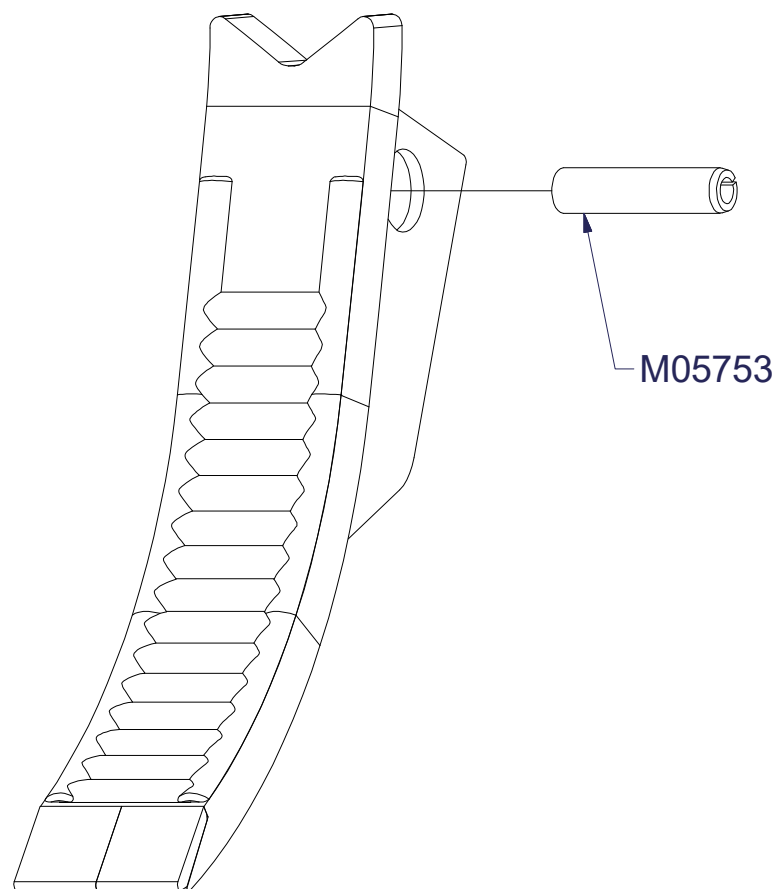

3011769

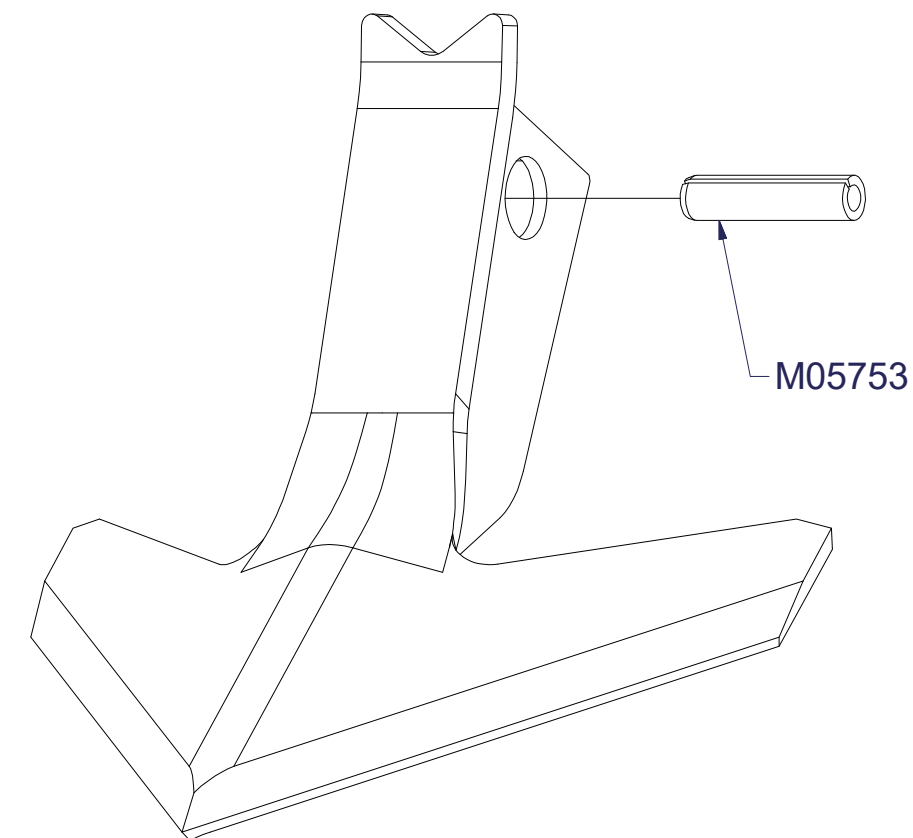

MACHINE	PCS.
FX 300 N	13
FX 350 N	16
FX 470 NS	22
FX 6,5	35
FX 8	43
FX 8,5	45
FX 10,5	57
FX 12,5	67

Ⓒ CZ TERČ PŘEDNÍ LEVÝ

Ⓓ D SCHILD, VORDERES, LINKES

Ⓕ F CIBLE AVANT GAUCHE

Ⓒ GB LEFT FRONT DISC

Ⓓ RU ЩИТОК ПЕРЕДНИЙ ЛЕВЫЙ

Ⓕ PL TARCZA PRZEDNIA LEWA



4019075

Pos.	Part Number	Pcs.
1	4019247	1
2	4019245	2
5	m16274	1
6	m16628	1
10	m16687	6
15	m03775	6

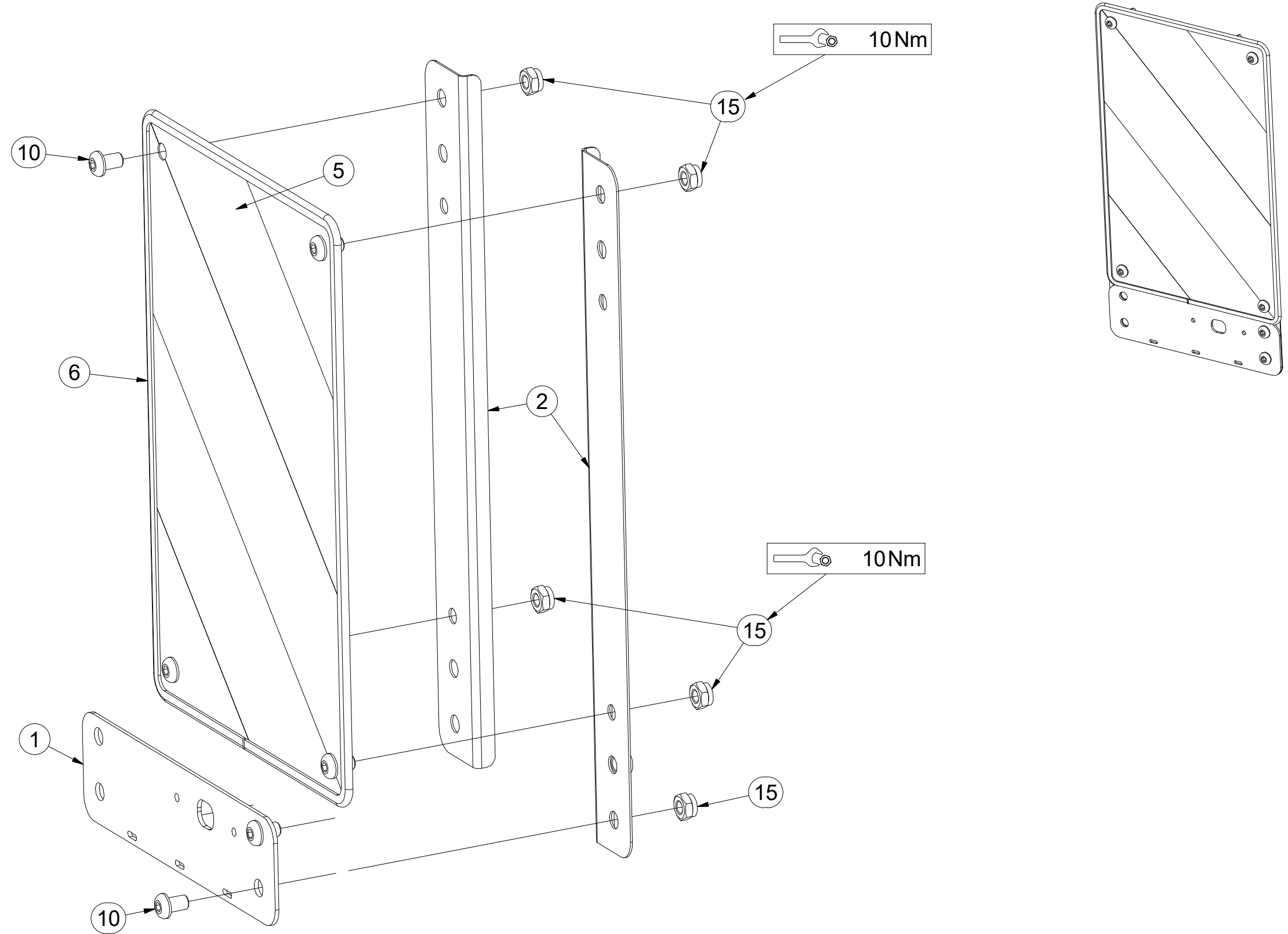

ⒸZ TERČ PŘEDNÍ PRAVÝ

Ⓓ SCHILD, VORDERES, RECHTES

Ⓕ CIBLE AVANT DROITE

ⒼB RIGHT FRONT DISC

ⒶU ЩИТОК ПЕРЕДНИЙ ПРАВЫЙ

ⒶL TARCZA PRZEDNIA PRAWA



4019076

Pos.	Part Number	Pcs.
1	4019247	1
2	4019245	2
5	m16273	1
6	m16628	1
10	m16687	6
15	m03775	6

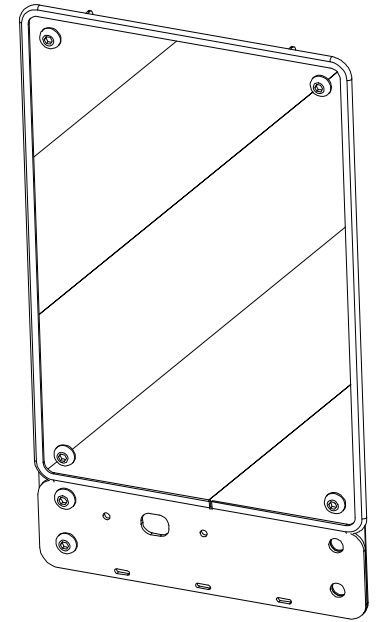
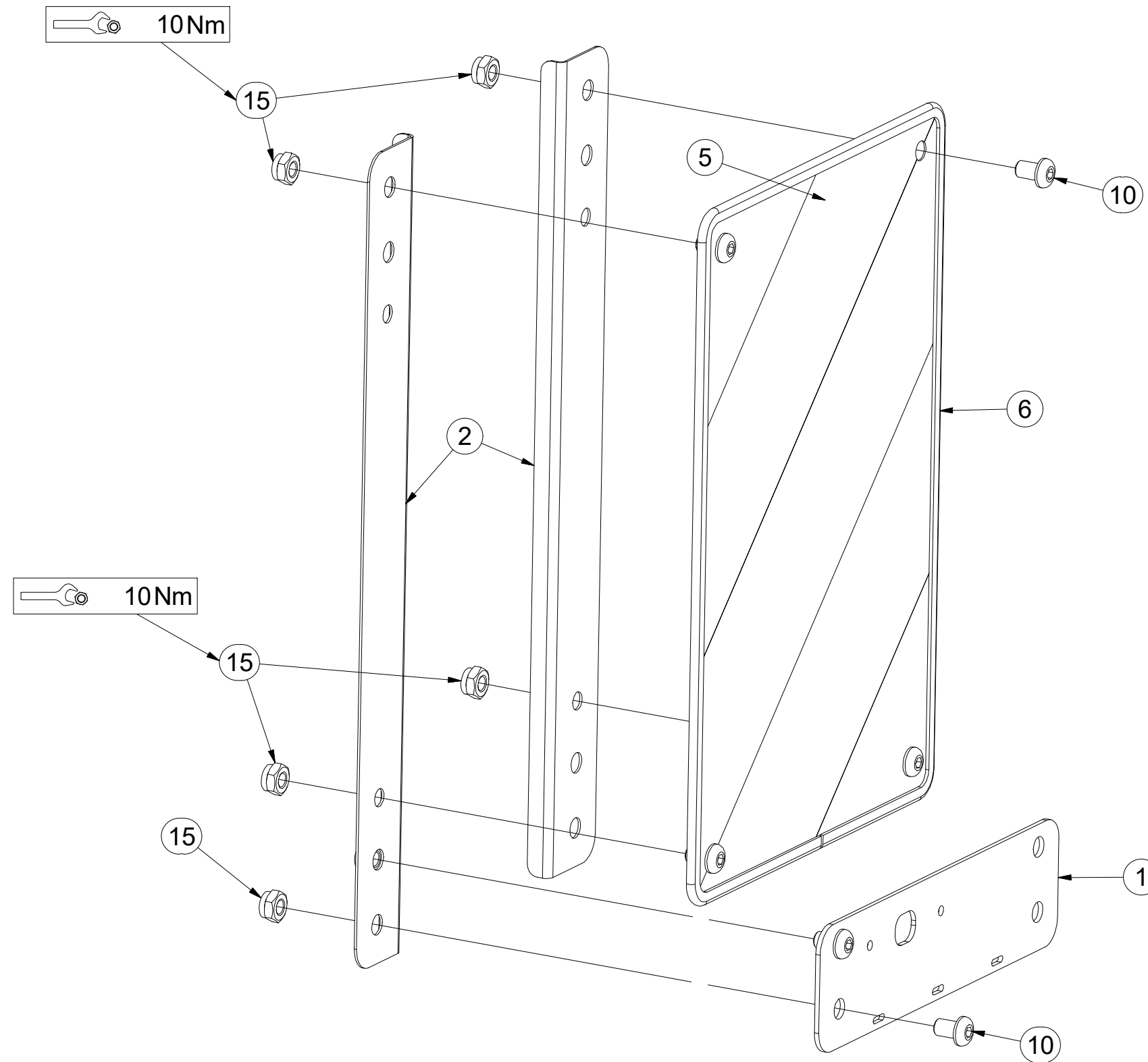

ⒸZ TERČ ZADNÍ PRAVÝ

Ⓓ SCHILD, HINTERES, RECHTES

Ⓕ CIBLE ARRIÈRE DROITE

3009685

ⒼB RIGHT REAR DISC

ⒺЩИТОК ЗАДНИЙ ПРАВЫЙ

ⒽL TARCZA TYLNA PRAWA

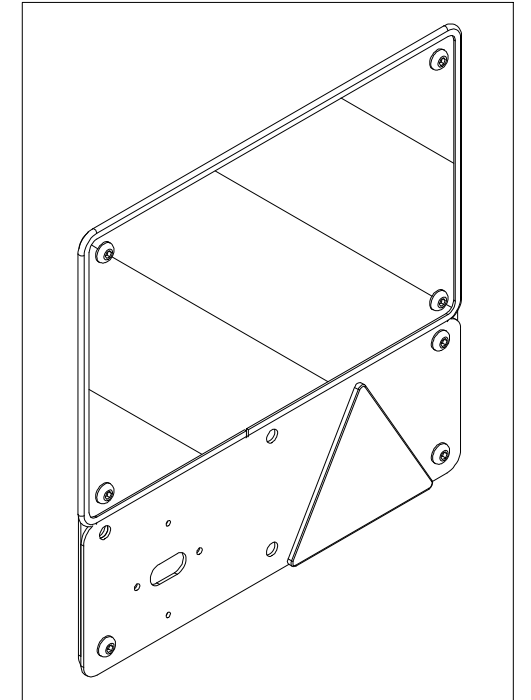
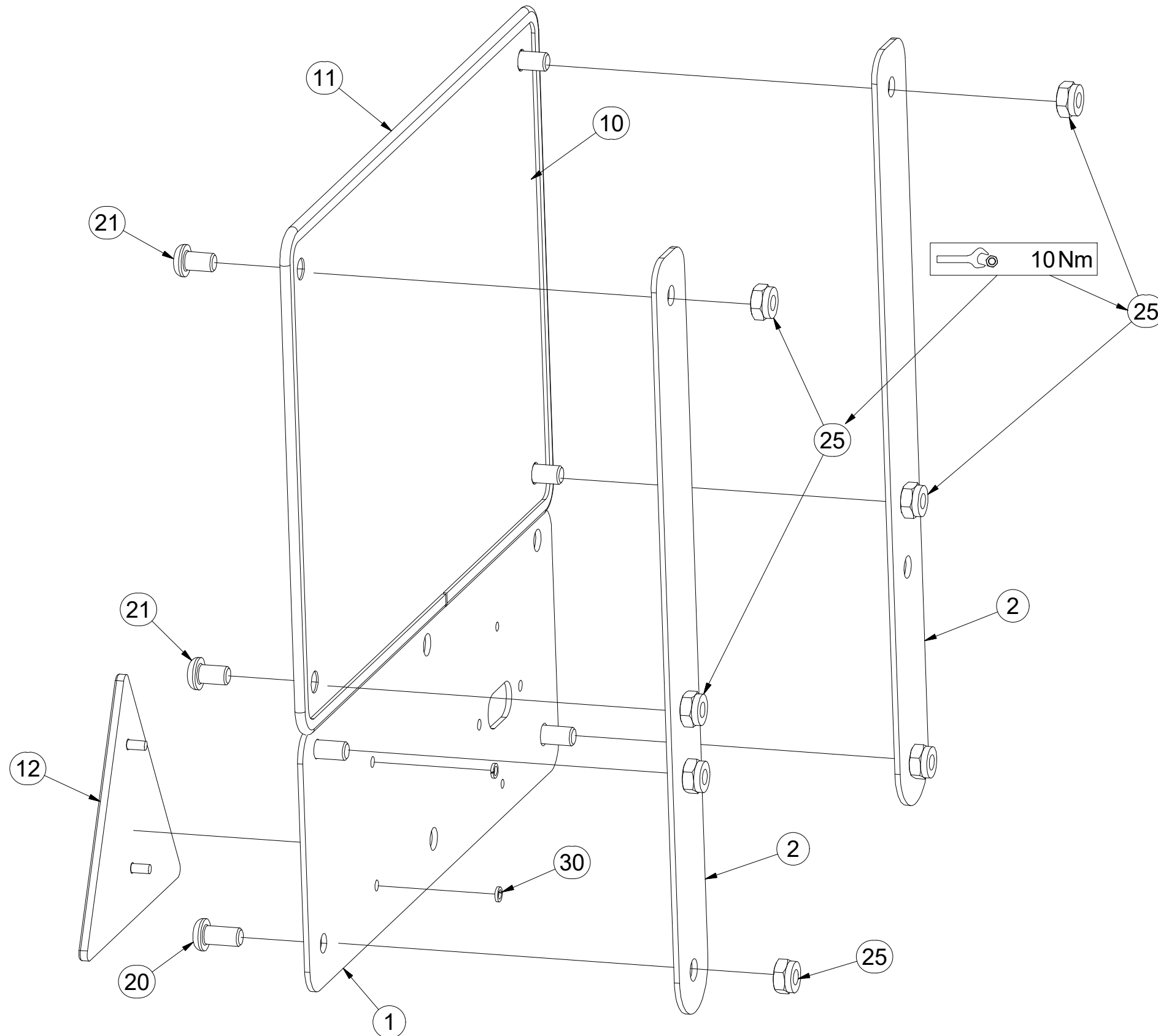

Pos.	Part Number	Pcs.
1	4019308	1
2	4023062	2
10	m17940	1
11	m16628	1,4
12	m02497	1
20	m16637	3
21	m16687	4
25	m03775	7
30	m01197	2

ⒸZ TERČ ZADNÍ LEVÝ

Ⓓ SCHILD, HINTERES, LINKES

Ⓕ CIBLE ARRIÈRE GAUCHE

ⒸB LEFT REAR DISC

ⒸU ЩИТОК ЗАДНИЙ ЛЕВЫЙ

ⒸL TARCZA TYLNA LEWA



3009686

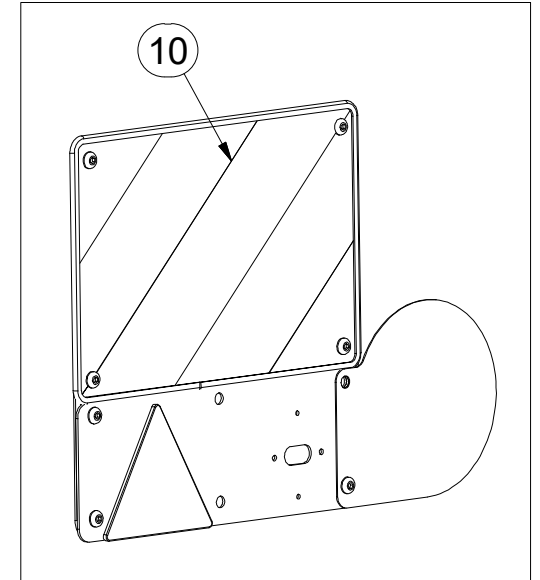
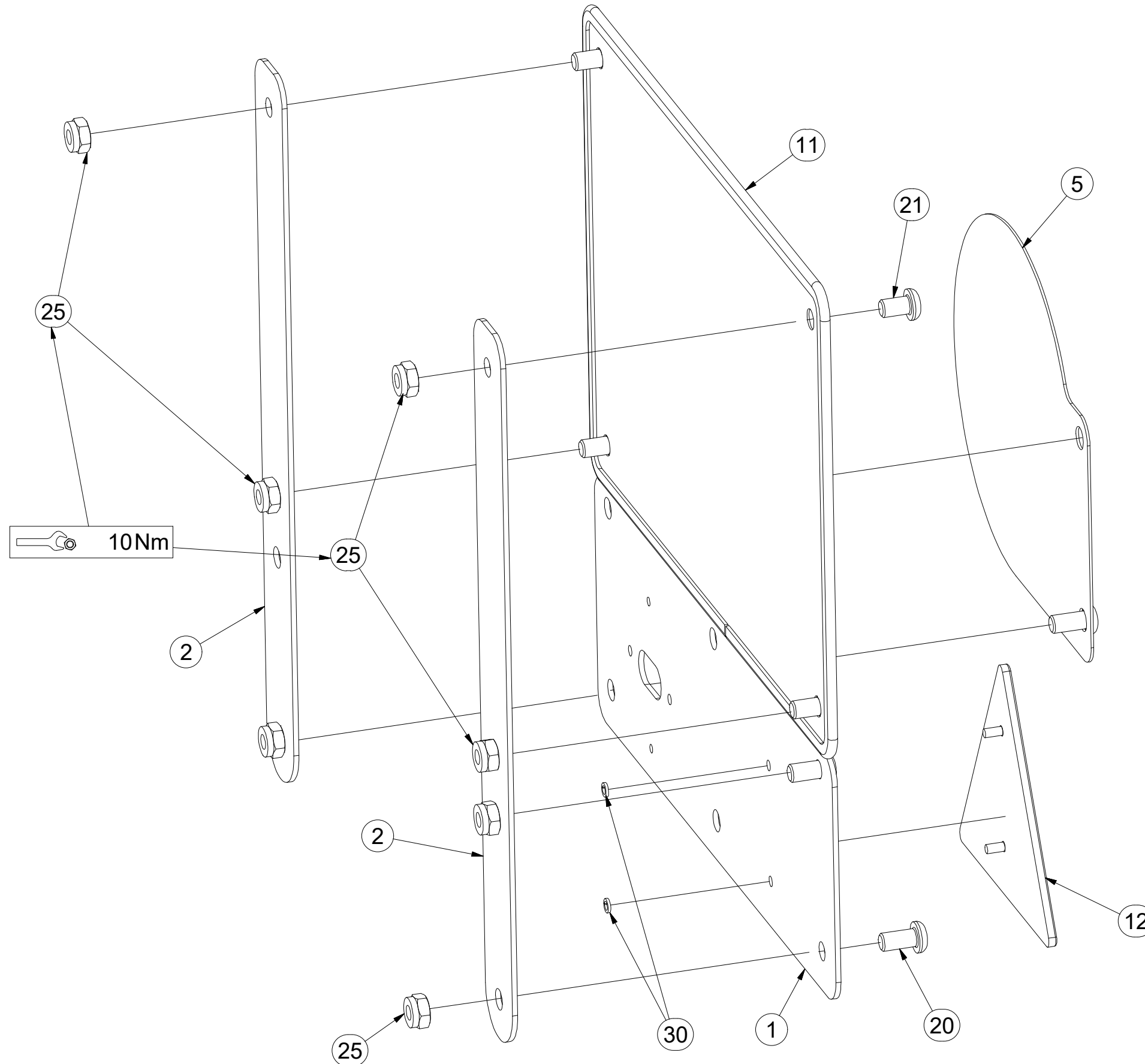

Pos.	Part Number	Pcs.
1	4019308	1
2	4023062	2
5	4019317	1
10	m17941	1
11	m16628	1,4
12	m02497	1
20	m16637	3
21	m16687	4
25	m03775	7
30	m01197	2

Ⓒ VÝSTRAŽNÝ TROJÚHELNÍK
Ⓓ WARNDREIECK
Ⓕ TRIANGLE D'AVERTISSEMENT

Ⓖ EMERGENCY TRIANGLE
Ⓡ ЗНАК АВАРИЙНОЙ ОСТАНОВКИ
Ⓟ TRÓJKĄT OSTRZEGAWCZY



3001210

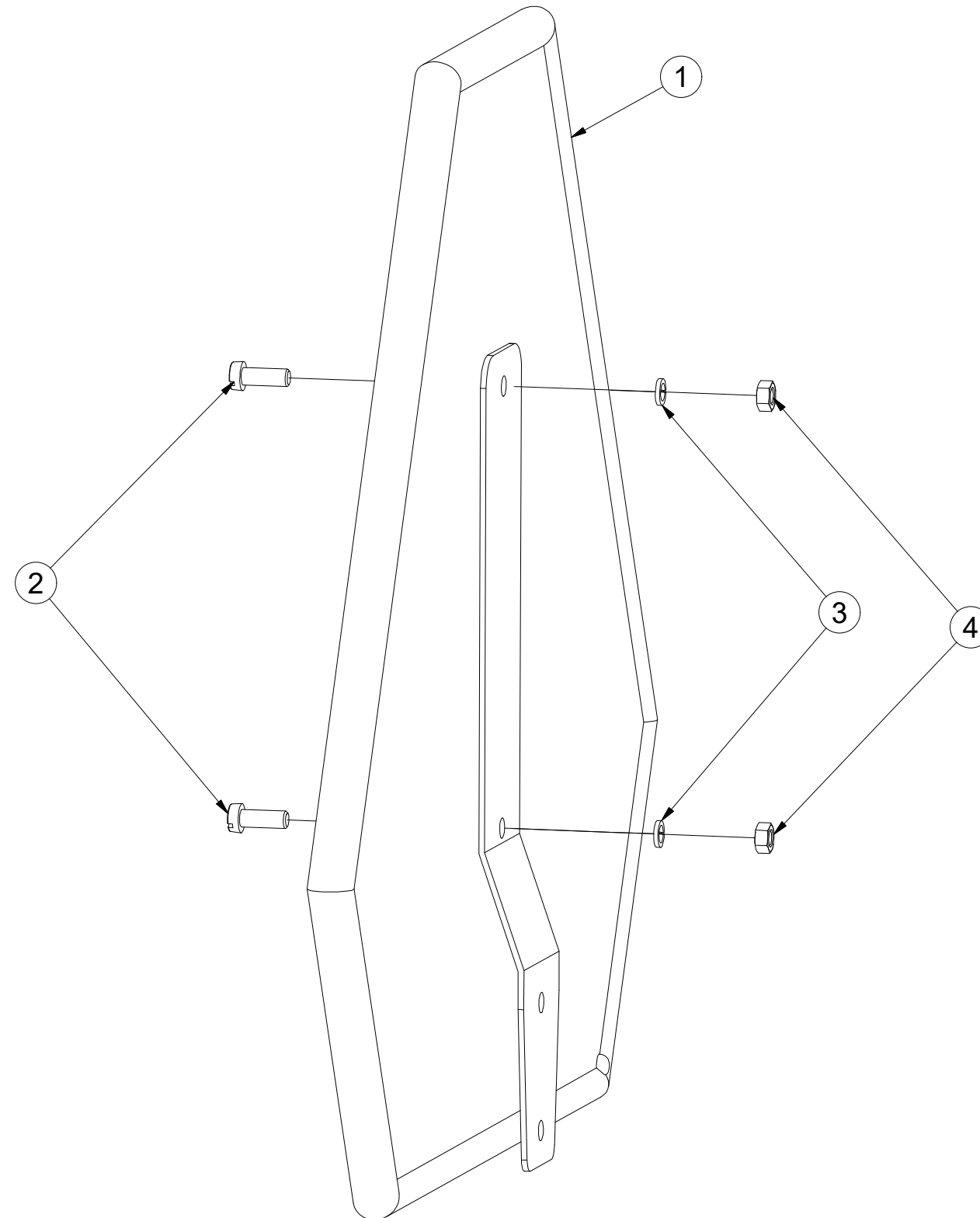

Pos.	Part Number	Pcs.
1	m05371	1
2	m11759	2
3	m01200	2
4	m01295	2

Ⓒ SADA ZADNÍCH VÁLCŮ
Ⓓ SATZ HINTERE WALZEN
Ⓕ KIT DE ROULEAUX ARRIÈRE

Ⓖ SET OF REAR ROLLERS
Ⓡ КОМПЛЕКТ ЗАДНИХ КАТКОВ
Ⓟ ZESTAW TYLNYCH WAŁÓW



3012076

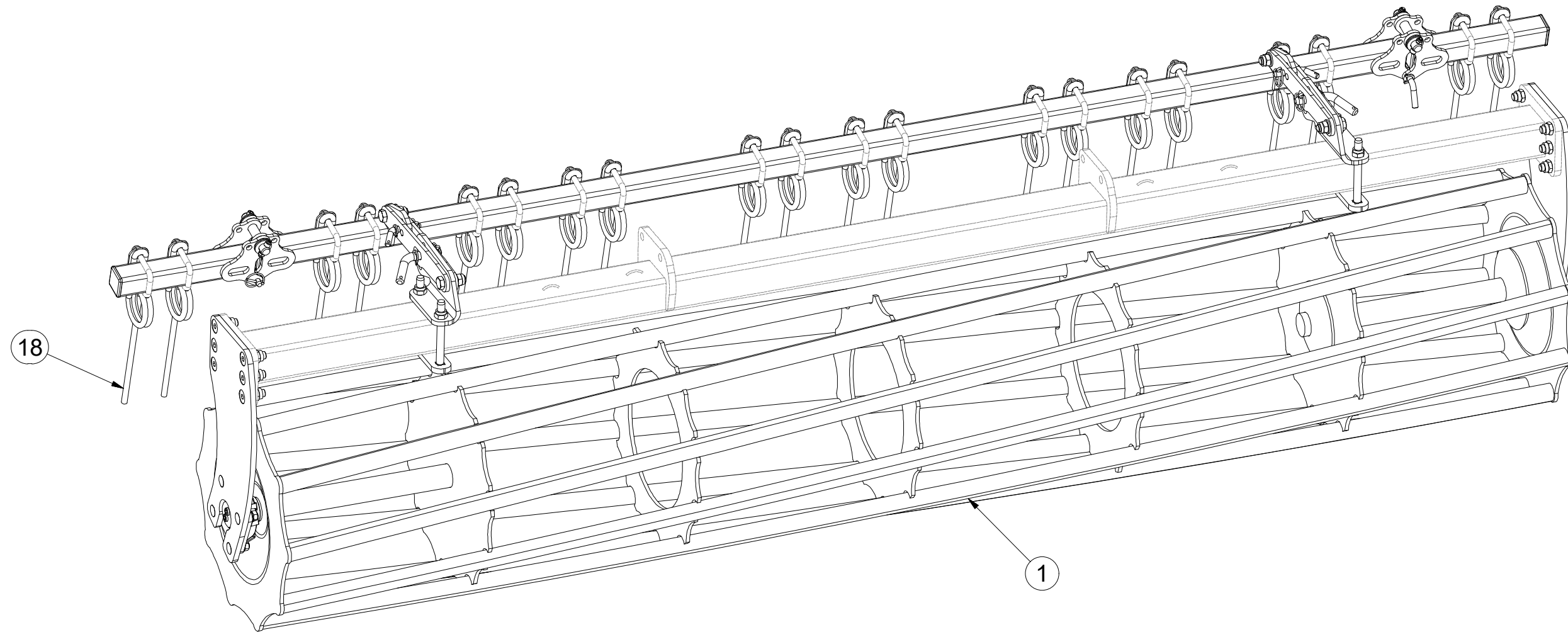

Pos.	Part Number	Pcs.
1	3003357	1
18	3003243	20

- Ⓒ SADA ZADNÍCH VÁLČŮ
- Ⓓ SATZ HINTERE WALZEN
- Ⓕ KIT DE ROULEAUX ARRIÈRE

- Ⓖ SET OF REAR ROLLERS
- Ⓡ КОМПЛЕКТ ЗАДНИХ КАТКОВ
- Ⓟ ZESTAW TYLNYCH WAŁÓW



3012076

Pos.	Part Number	Pcs.
7	4014034	2
9	4016809	4
10	4017124	2
12	4018188	1
13	4018189	1
30	m04249	4
32	m11154	8
34	m14672	12
40	m10439	8
41	m13846	12
51	m01208	4
52	m03988	8
64	m15625	2

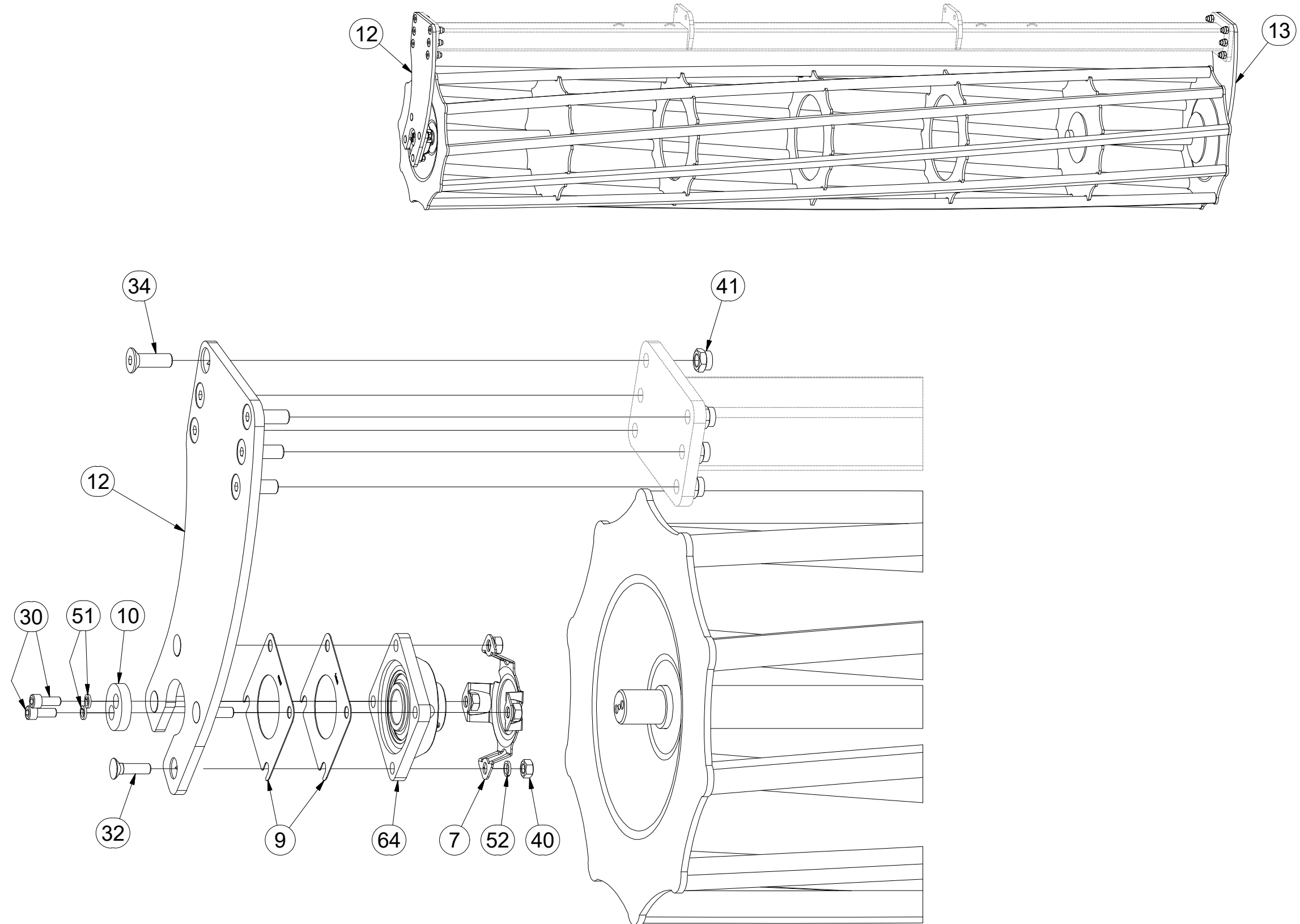

CZ SADA ZADNÍCH VÁLCŮ
 D SATZ HINTERE WALZEN
 F KIT DE ROULEAUX ARRIÈRE

GB SET OF REAR ROLLERS
 RU КОМПЛЕКТ ЗАДНИХ КАТКОВ
 PL ZESTAW TYLNYCH WAŁÓW



3012076

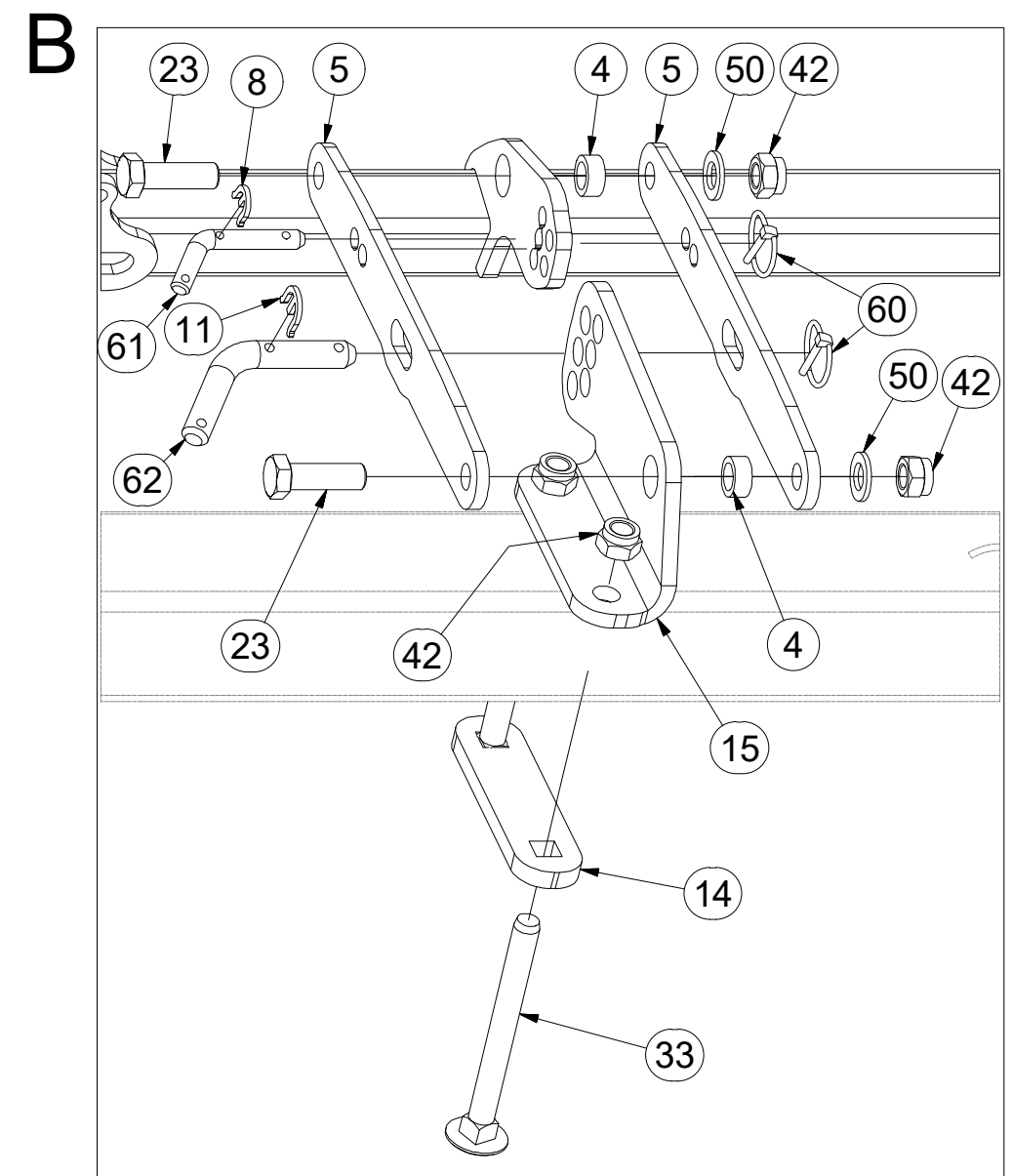
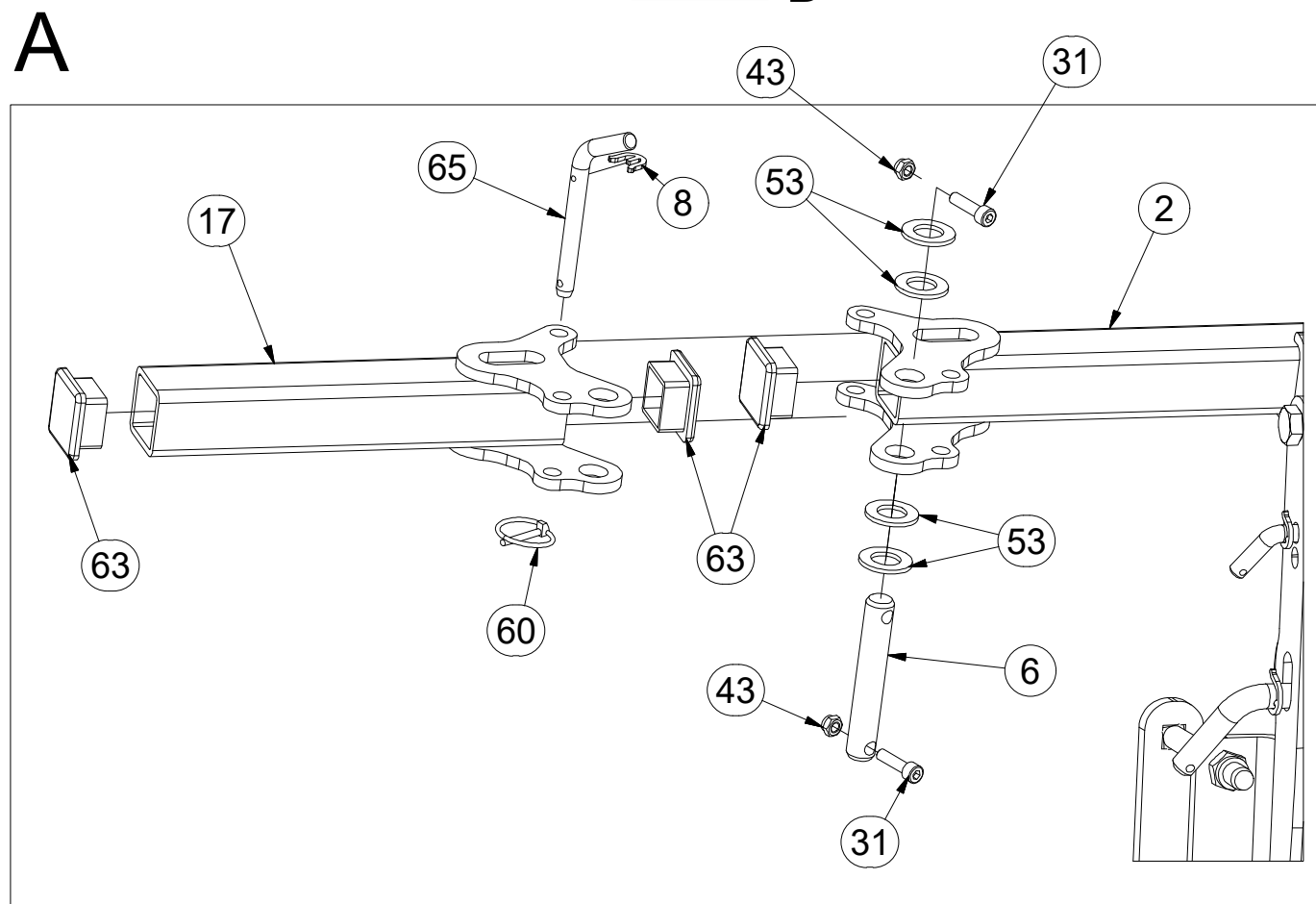
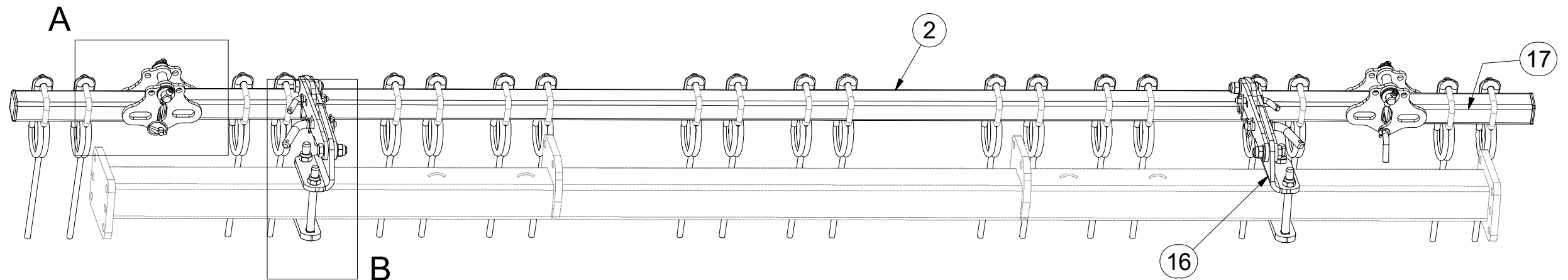

Pos.	Part Number	Pcs.	Pos.	Part Number	Pcs.	Pos.	Part Number	Pcs.
2	3012051	1	15	4018317	1	43	m04503	4
4	4002505	4	16	4018318	1	50	m01219	4
5	4006009	4	17	4024185	2	53	m14030	8
6	4008203	2	23	m04355	4	60	m10454	6
8	4016279	4	31	m09870	4	61	m09141	2
11	4017136	2	33	m16839	4	62	m09436	2
14	4018316	2	42	m03683	8	63	m09445	6
						65	m17878	2

Ⓒ ZAVLAČOVAČ

Ⓓ SCHLEPPE

Ⓕ HERSE

3003243

Ⓖ LEVELLING BAR

Ⓡ ЗАКРЫВАТЕЛЬ ШАГ

Ⓟ ZAGARNIACZ

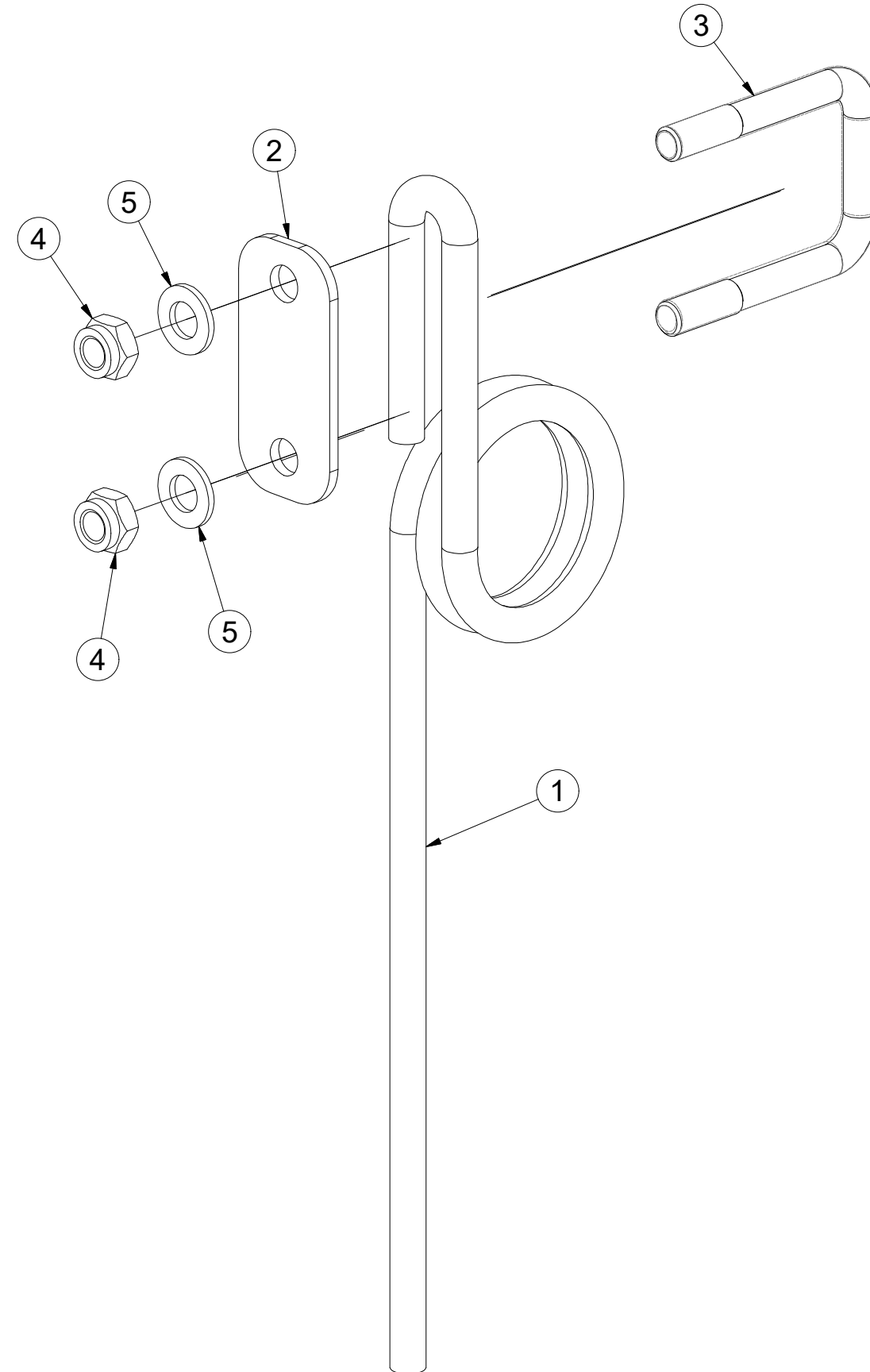

Pos.	Part Number	Pcs.
1	9002044	1
2	4001429	1
3	m10295	1
4	m04301	2
5	m01214	2

☉ TÁHLO
☉ STANGE
☉ TIGE DE TRACTION

☉ DRAWBAR
☉ ТЯГА
☉ PRĘT



3012152

Pos.	Part Number	Pcs.
1	3004965	2

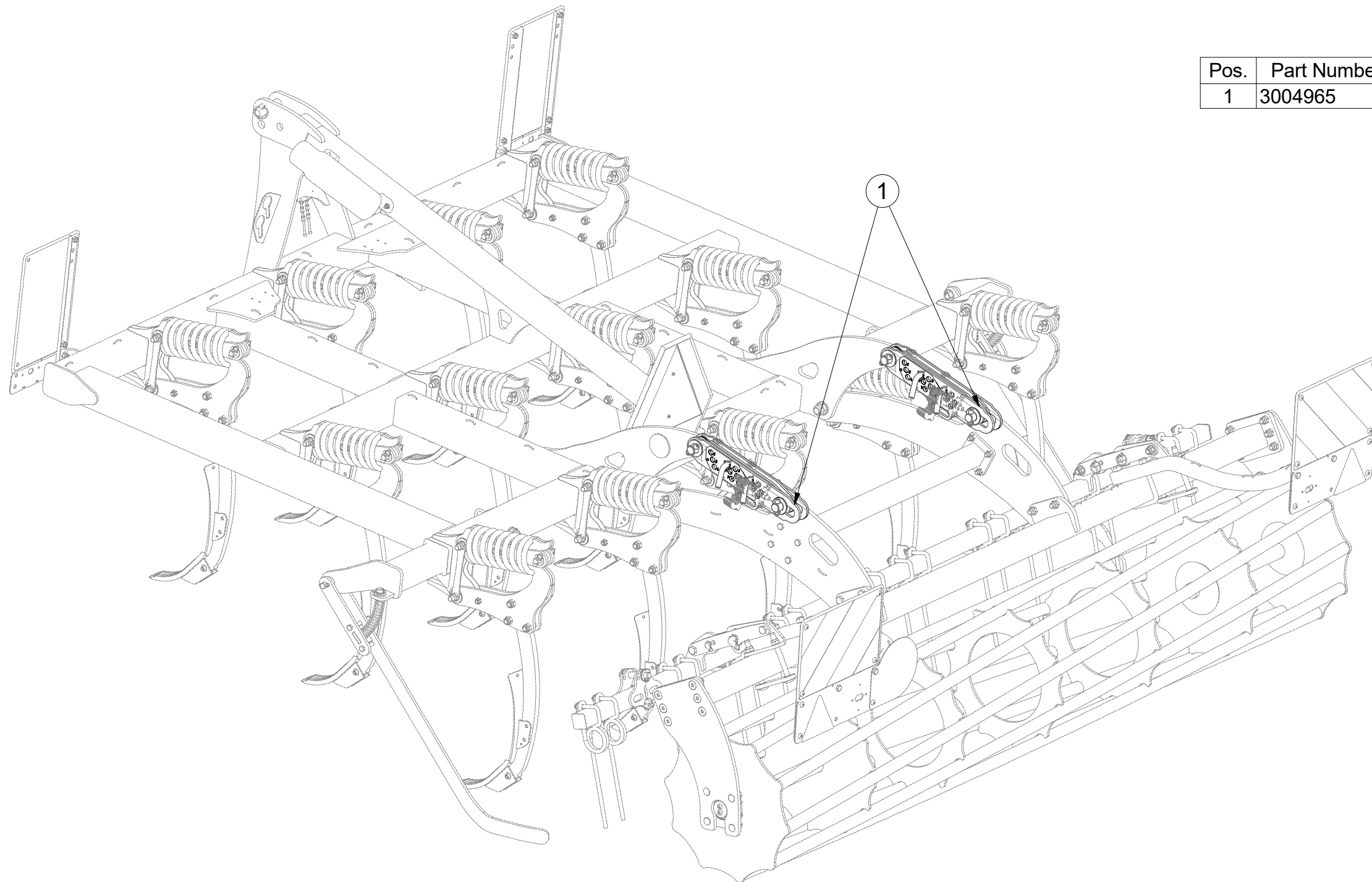

☉ TÁHLO

☉ STANGE

☉ TIGE DE TRACTION

3004965

☉ DRAWBAR

☉ ТЯГА

☉ PRĘT

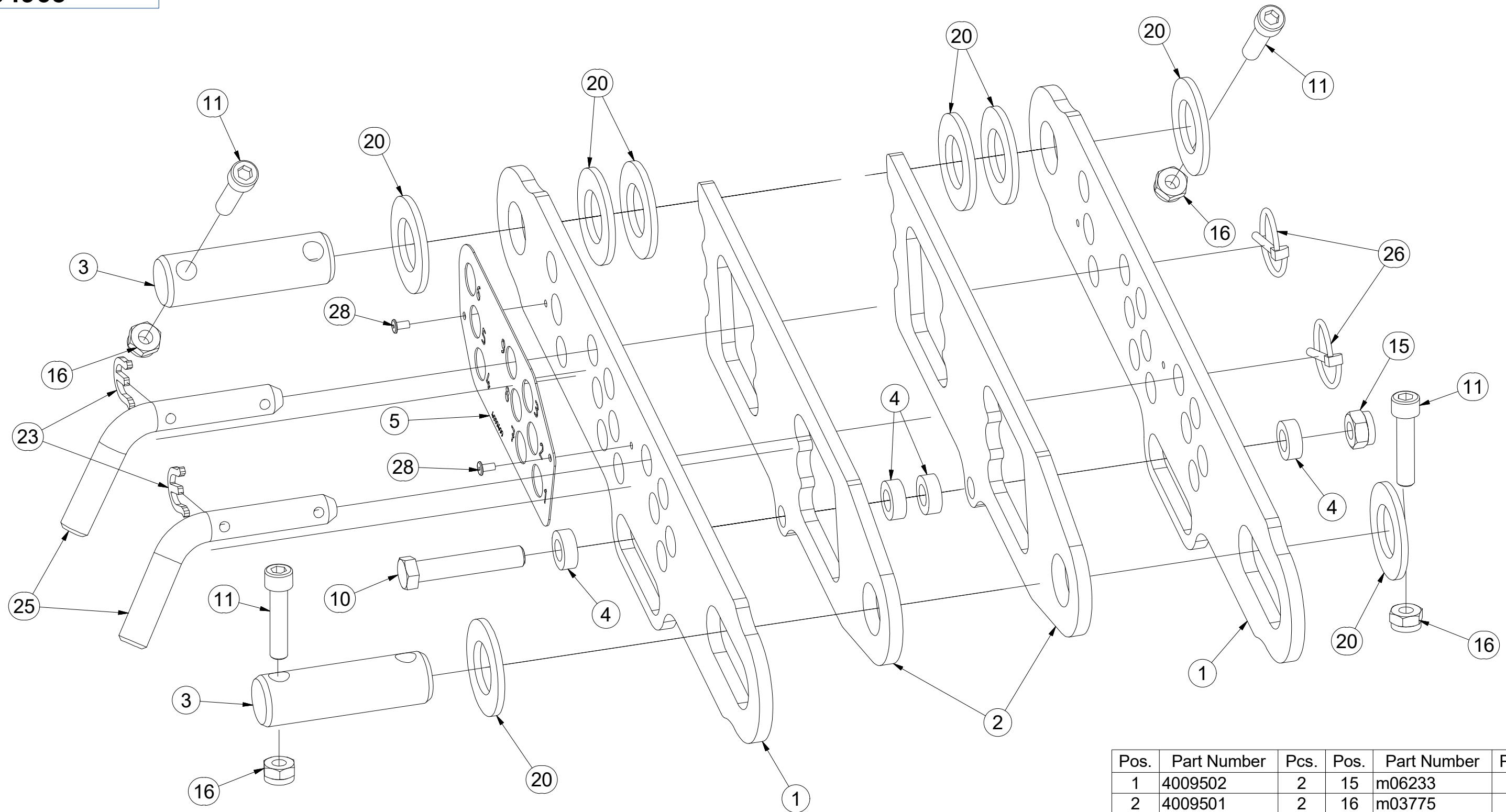

Pos.	Part Number	Pcs.	Pos.	Part Number	Pcs.
1	4009502	2	15	m06233	1
2	4009501	2	16	m03775	4
3	4008234	2	20	m02866	8
4	4009504	4	23	4017136	2
5	4009499	1	25	m10312	2
10	m05898	1	26	m10454	2
11	m14143	4	28	m05587	2

Ⓒ SVĚTELNÁ SADA

Ⓓ LEUCHTENSATZ

Ⓕ KIT LUMINEUX

Ⓒ LIGHTING SET

Ⓔ ОСВЕТИТЕЛЬНЫЙ КОМПЛЕКТ

Ⓗ ZESTAW OŚWIETLENIA



3008987

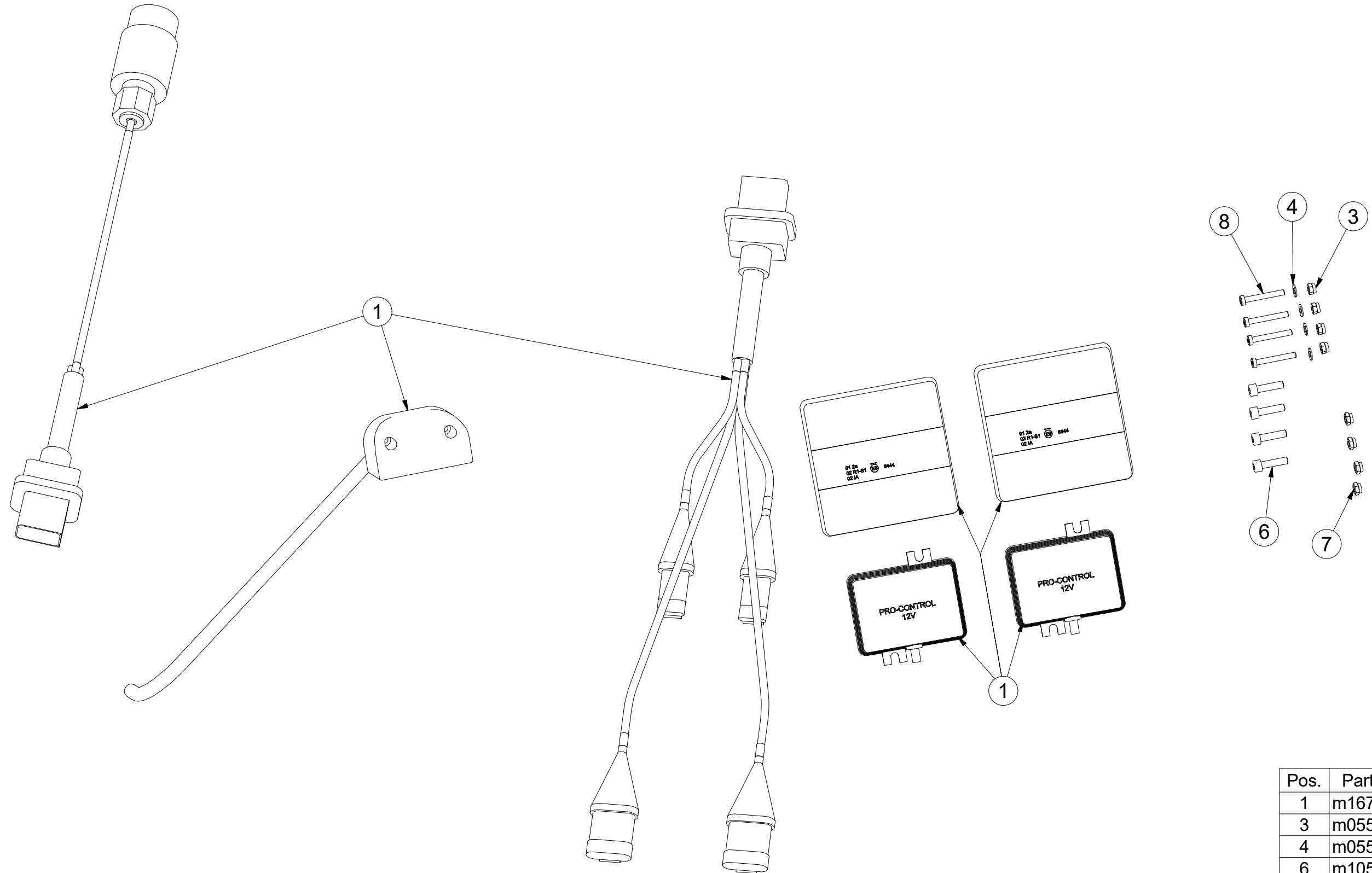

Pos.	Part Number	Pcs.
1	m16769	1
3	m05562	4
4	m05597	4
6	m10591	4
7	m06236	4
8	m16861	4
30	m05566	50

Ⓒ SVĚTELNÁ SADA

Ⓓ LEUCHTENSATZ

Ⓕ KIT LUMINEUX

m16769

Ⓖ LIGHTING SET

Ⓡ ОСВЕТИТЕЛЬНЫЙ КОМПЛЕКТ

Ⓢ ZESTAW OŚWIETLENIA

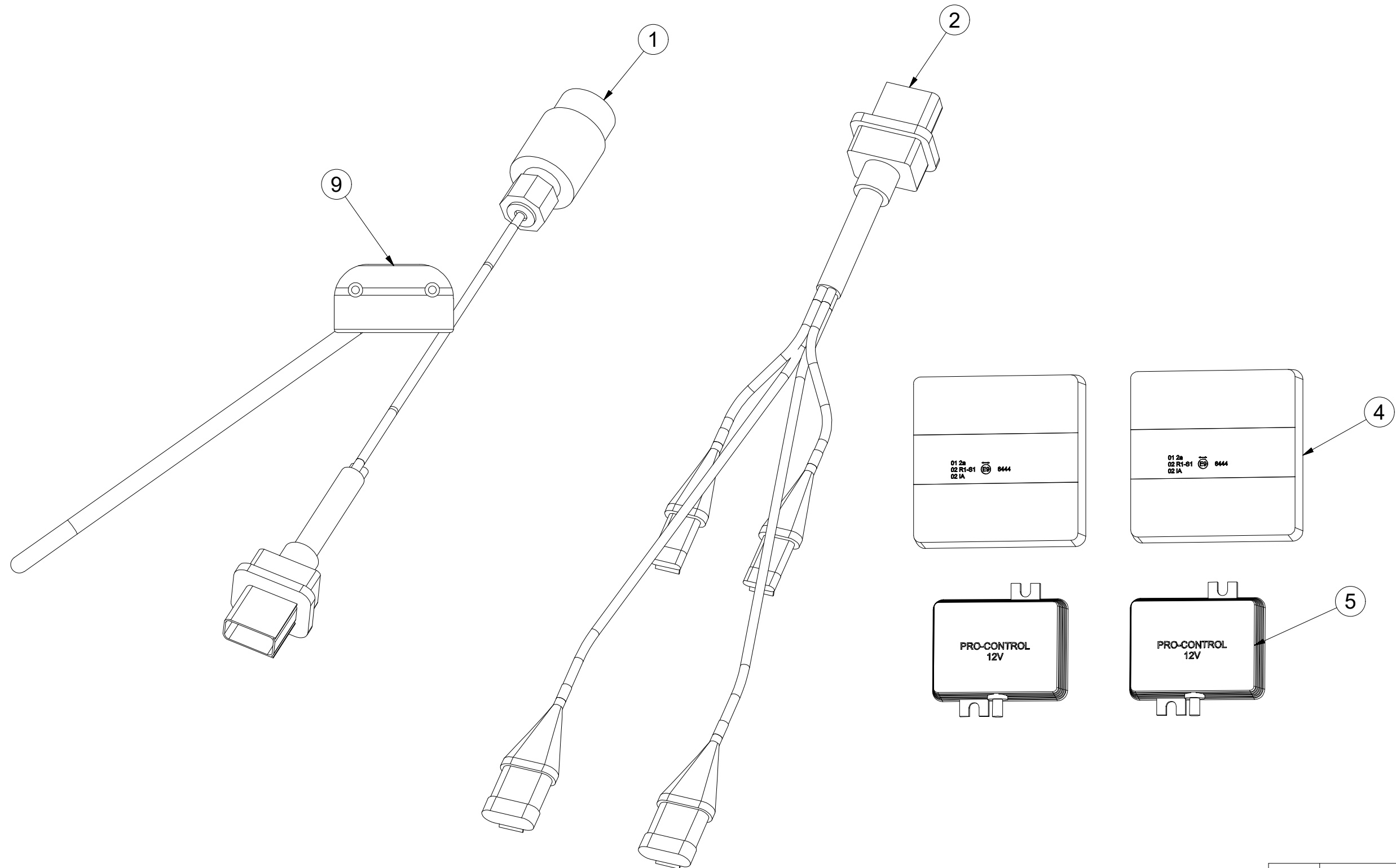

Pos.	Part Number	Pcs.
1	m15862	1
2	m14778	1
4	m14865	2
5	m14777	2
9	m15863	1

☉ SAMOLEPKY STROJE

☉ AUFKLEBER MASCHINEN

☉ VOITURE MACHINES

☉ STICKERS MACHINES

☉ СТИКЕРЫ МАШИНЫ

☉ NAKLEJKI MASZYNY



8001093-30003

Pos.	Part Number	Pcs.
1	m03315	2
2	m04359	2
3	m04361	2
4	m04365	4
5	m04366	2
6	m04369	2
7	m10353	2
8	m10445	2
9	m10536	2
10	m13116	6

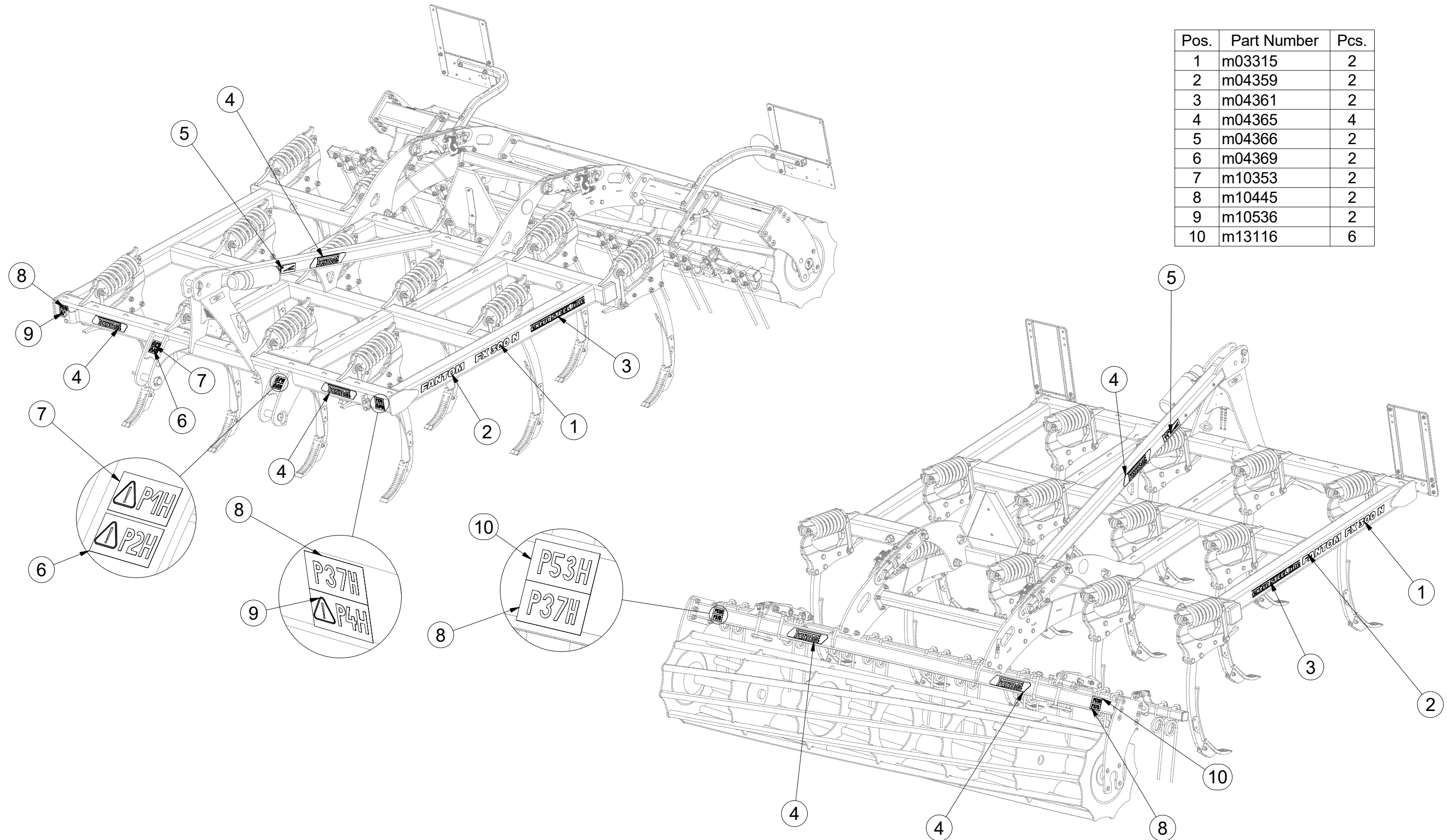

- Ⓒ UTAHOVACÍ MOMENTY ŠROUBŮ
 Ⓓ ANZUGMOMENTE VON SCHRAUBEN
 Ⓕ COUPLES DE SERRAGE DES VIS

- Ⓖ SCREW TIGHTENING TORQUE
 Ⓔ МОМЕНТЫ ЗАЖАТИЯ БОЛТОВ
 Ⓗ MOMENTY DOKRĘCANIA ŚRUB



P		5.8	8.8	10.9	12.9
D	R	Mu	Mu	Mu	Mu
mm	mm	Nm	Nm	Nm	Nm
M 6	1	6	9	13	15
M 8	1,25	14	22	32	38
M10	1,5	29	44	64	75
M12	1,75	49	76	111	130
M14	2	79	120	176	206
M16	2	123	188	276	323
M18	2,5	169	257	378	443
M20	2,5	239	365	536	628
M22	2,5	329	529	738	864
M24	3	413	629	924	1082
M27	3	613	934	1372	1606
M30	3,5	832	1267	1862	2179
M33	3,5	1130	1723	2530	2961
M36	4	1451	2210	3246	3799
M39	4	1885	2872	4217	4936
M42	4,5	2322	3538	5196	6080
M45	4,5	2909	4433	6511	7619
M48	5	3513	5353	7862	9200
M52	5	4524	6895	10126	11849
M56	5,5	5636	8589	12614	14761

- Mu - Ⓒ UTAHOVACÍ MOMENT Ⓖ TIGHTENING TORQUE
 Ⓓ ANZUGMOMENT Ⓔ МОМЕНТ ЗАЖАТИЯ
 Ⓕ COUPLE DE SERRAGE Ⓗ MOMENT DOKRĘCANIA
 D - Ⓒ JMENOVITÝ PRŮMĚR Ⓖ NOMINAL DIAMETER
 Ⓓ NENNDURCHMESSER Ⓔ НОМИНАЛЬНЫЙ ДИАМЕТР
 Ⓕ DIAMETRE NOMINAL Ⓗ ŚREDNICA NOMINALNA
 R - Ⓒ ROZTEČ ZÁVITU - STOUPÁNÍ Ⓖ SCREW PITCH – LEAD
 Ⓓ GEWINDESTEIGUNG Ⓔ ШАГ РЕЗЬБЫ
 Ⓕ PAS DE FILET - PAS Ⓗ ROZSTAW GWINTU - SKOKI
 P - Ⓒ PEVNOST Ⓖ STRENGTH
 Ⓓ FESTIGKEIT Ⓔ ПРОЧНОСТЬ
 Ⓕ RÉSISTANCE Ⓗ WYTRZYMAŁOŚĆ

- Ⓒ Šroubové spoje utahujte dle vyznačeného utahovacího momentu v dokumentaci. Pokud není utahovací moment v dokumentaci vyznačen, utahujte dle obecné tabulky. Pokud je v dokumentaci definován spoj ze šroubu a matice o různých pevnostech, vždy utahujte na moment komponenty s nižší pevností.
- Ⓓ Ziehen Sie die Schraubverbindungen gemäß dem in der Dokumentation festgeschriebenen Anzugsmoments an. Sofern das Anzugsmoment nicht in der Dokumentation aufgeführt ist, ziehen Sie sie gemäß der allgemeinen Tabelle an. Wenn in der Dokumentation eine Verbindung von Schraube und Mutter mit verschiedenen Festigkeiten definiert ist, wird immer mit dem Moment des Bauteils mit der geringeren Festigkeit angezogen.
- Ⓕ Serrez les raccords à vis selon le couple de serrage indiqué dans les documents. Si le couple de serrage n'est pas indiqué dans les documents, serrez selon le tableau général. Si les documents définissent un assemblage par boulon de diverses résistances, serrez toujours au moment de la composante avec résistance inférieure.
- Ⓖ Tighten the screw joints according to the tightening torque stated in the documentation. If the tightening torque is not stated in the documentation, tighten according to the general table. If there is a joint with a screw and a nut at different strengths in the documentation, always tighten to the torque of the component with lower strength.
- Ⓔ Резьбовые соединения зажимайте с установленным в документации моментом зажатия. Если в документации не указан момент зажатия, то зажимайте по действующей в общем таблице. Если в документации установлено соединение из болта и гайки различной прочности, всегда зажимайте с моментом для компонента с меньшей прочностью.
- Ⓗ Połączenia śrubowe należy dokręcać zgodnie z momentem obrotowym w dokumentacji. Jeśli w dokumentacji nie ma podanego momentu obrotowego, należy dokręcać zgodnie z ogólną tabelą. Jeśli w dokumentacji zdefiniowane jest połączenie ze śrubą i nakrętką o różnych wytrzymałościach, zawsze należy dokręcać zachowując moment dokręcania komponentu z niższą wytrzymałością.

- Ⓒ UTAHOVACÍ MOMENTY ŠROUBŮ
 Ⓓ ANZUGMOMENTE VON SCHRAUBEN
 Ⓕ COUPLES DE SERRAGE DES VIS

- Ⓖ SCREW TIGHTENING TORQUE
 Ⓔ МОМЕНТЫ ЗАЖАТИЯ БОЛТОВ
 Ⓟ MOMENTY DOKRĘCANIA ŚRUB



- Ⓒ **OBECNÝ PŘEDPIS UTAHOVÁNÍ ZAJIŠTĚNÍ ČEPOVÝCH SPOJŮ:**
 Ⓓ **ALLGEMEINE VORSCHRIFT FÜR DAS ANZIEHEN VON BOLZENVERBINDUNGEN:**
 Ⓕ **CONSIGNE GENERALE POUR LE SERRAGE DES ARTICULATIONS CYLINDRIQUES:**
 Ⓖ **GENERAL INSTRUCTION FOR TIGHTENING THE SECURING OF PIN JOINTS:**
 Ⓔ **ОБЩЕЕ ОПИСАНИЕ ЗАЖАТИЯ ПРЕДОХРАНЕЕНИЯ СОЕДИНЕНИЙ ПАЛЬЦАМИ:**
 Ⓟ **OGÓLNE ZASADY DOKRĘCANIA ZABEZPIECZENIA POŁĄCZEŃ CZOPEM:**

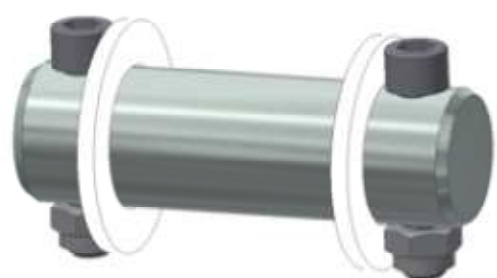

X	M
M8, M10, M12	09-15Nm
M14	15-25Nm

- | | | | |
|------------------------|------------------|-------------------------|-------------------------|
| X - Ⓒ ROZMĚR ŠROUBU | Ⓖ BOLT DIMENSION | M - Ⓒ ORIENTAČNÍ MOMENT | Ⓖ ORIENTATION TORQUE |
| Ⓓ SCHRAUBENGRÖSSE | Ⓔ РАЗМЕР БОЛТА | Ⓓ ANZUGSMOMENT | Ⓔ ОПИЕНТАЦИОННЫЙ МОМЕНТ |
| Ⓕ DIMENSIONS DE LA VIS | Ⓟ ROZMIAR ŚRUBY | Ⓕ COUPLE D'ORIENTATION | Ⓟ ORIENTACYJNY MOMENT |

- Ⓒ Tyto spoje není nutné ověřovat kontrolou momentovým klíčem = stačí vizuálně kontrolovat sešroubování.
 Ⓓ Diese Verbindungen müssen nicht mit einem Drehmomentschlüssel überprüft werden = es genügt, die Verschraubung visuell zu kontrollieren.
 Ⓕ Il n'est pas nécessaire de contrôler le serrage à l'aide d'une clé dynamométrique = un contrôle visuel de l'assemblage suffit.
 Ⓖ These joints do not have to be verified by checking with a torque wrench = visual inspection of bolting is sufficient.
 Ⓔ Эти соединения не нужно контролировать динамометрическим ключом = достаточно визуально проверять прикручивание.
 Ⓟ Nie trzeba sprawdzać tych połączeń kluczem dynamometrycznym = wystarczy wizualnie skontrolować dokręcenie.