

The effective technology

Farmet®

ⒸZ KATALOG NÁHRADNÍCH DÍLŮ ⒸB CATALOGUE OF SPARE PARTS ⒸD ERSATZTEILLISTE
ⒸRU КАТАЛОГ ЗАПАСНЫХ ЧАСТЕЙ ⒸF CATALOGUE DES PIÈCES DE RECHANGE ⒸPL KATALOG CZĘŚCI ZAMIENNYCH

SOFTER 3 N

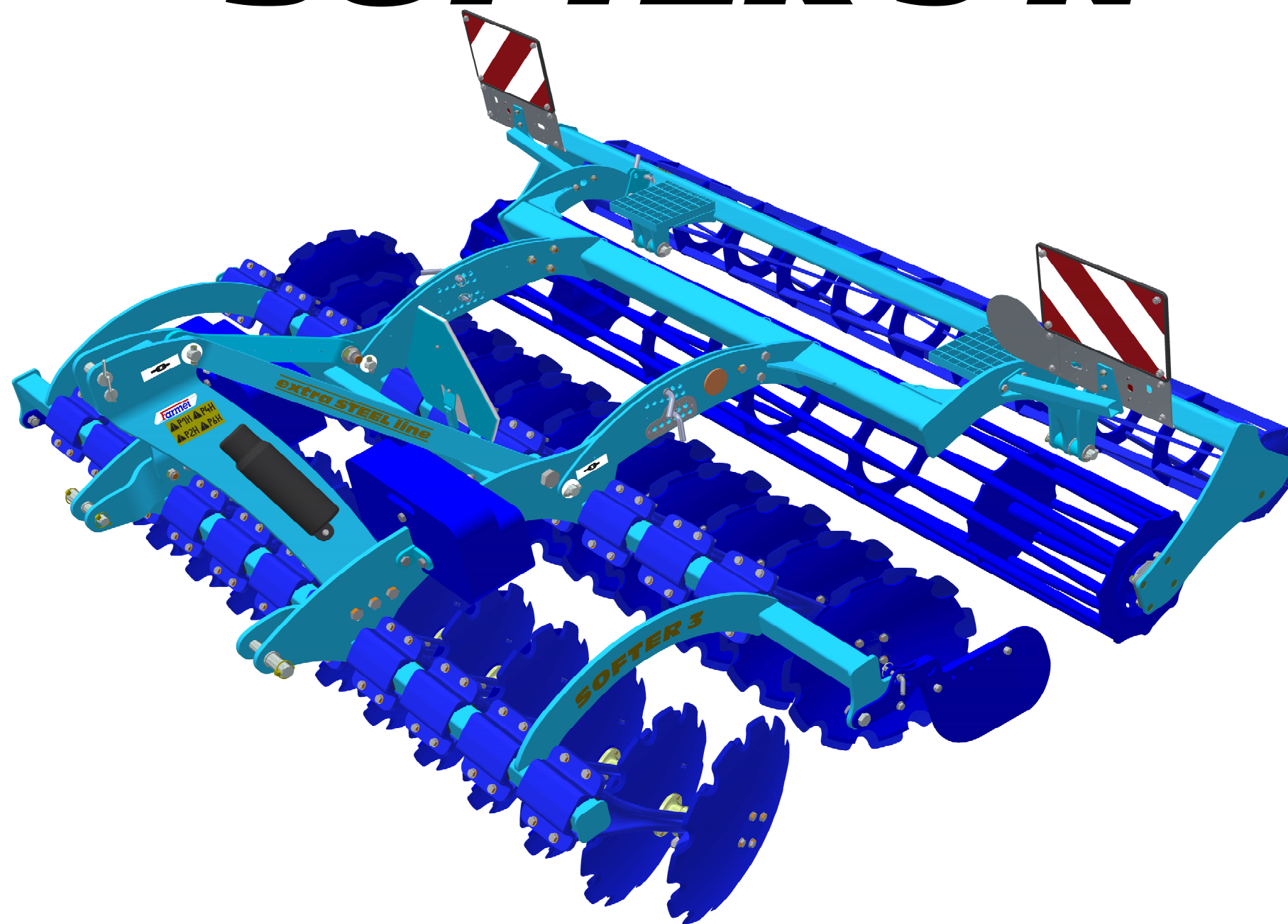

ⒸZ Platnost pro vrcholové | výrobní číslo stroje ⒸB Validity for the top | serial number of the machine
ⒸD Gültigkeit für die Haupt- | Herstellungsnummer der Maschine ⒸRU Действительно для главного | заводского номера машины
ⒸF Validité du numéro de référence | de série de la machine ⒸPL Obowiązuje dla numeru głównego | seryjnego maszyny

9316301 | 2018/0826

Farmet a. s.
Jiřinková 276
552 03 Česká Skalice, CZ

telefon: +420 491 450 111
fax: +420 491 450 136
GSM: +420 774 715 738

IČ: 46504931
DIČ: CZ46504931

web: www.farmet.cz
e-mail: farmet@farmet.cz

ⒸZ NAVIGACE STROJE

Ⓓ NAVIGATION DER MASCHINE

Ⓕ NAVIGATION DE LA MACHINE

ⒸB NAVIGATION OF THE MACHINE

ⒸU НАВИГАЦИЯ МАШИНЫ

ⒸL NAWIGACJA MASZYNY

Farmet

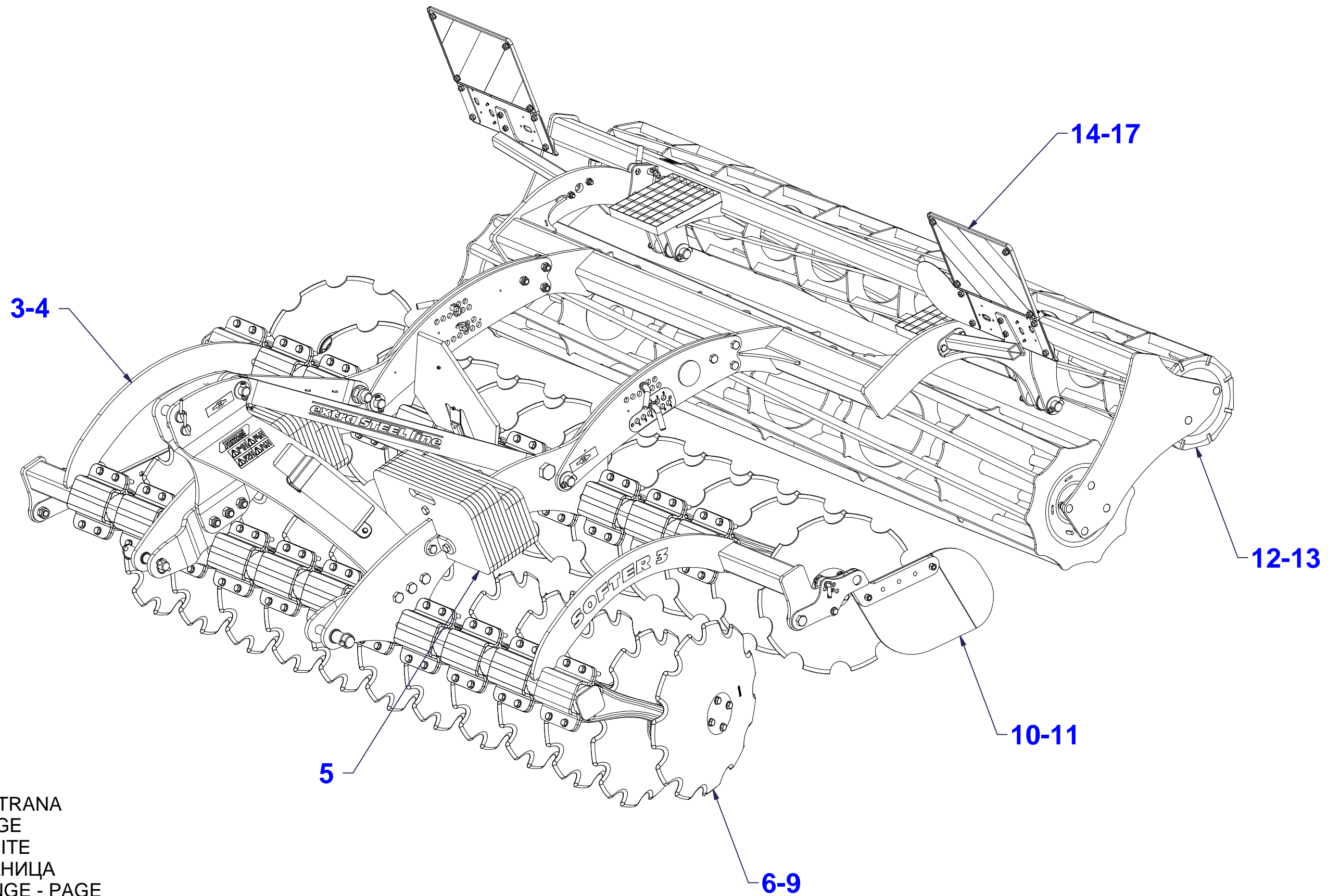

ⒸZ NÁHRADNÍ DÍL - STRANA

ⒸB SPARE PART - PAGE

Ⓓ ERSATZTEILE - SEITE

ⒸU ЗАПЧАСТЬ - СТРАНИЦА

Ⓕ PIÈCE DE RECHANGE - PAGE

ⒸL CZĘŚCI ZAMIENNE - STRONA

Ⓒ ZÁKLAD STROJE

Ⓓ UNTERBAU DER MASCHINE

Ⓕ BÂTI DE LA MACHINE

Ⓖ FOOTING OF THE MACHINE

Ⓡ ОСНОВАНИЕ МАШИНЫ

Ⓢ PODSTAWA MASZYNY



3008104

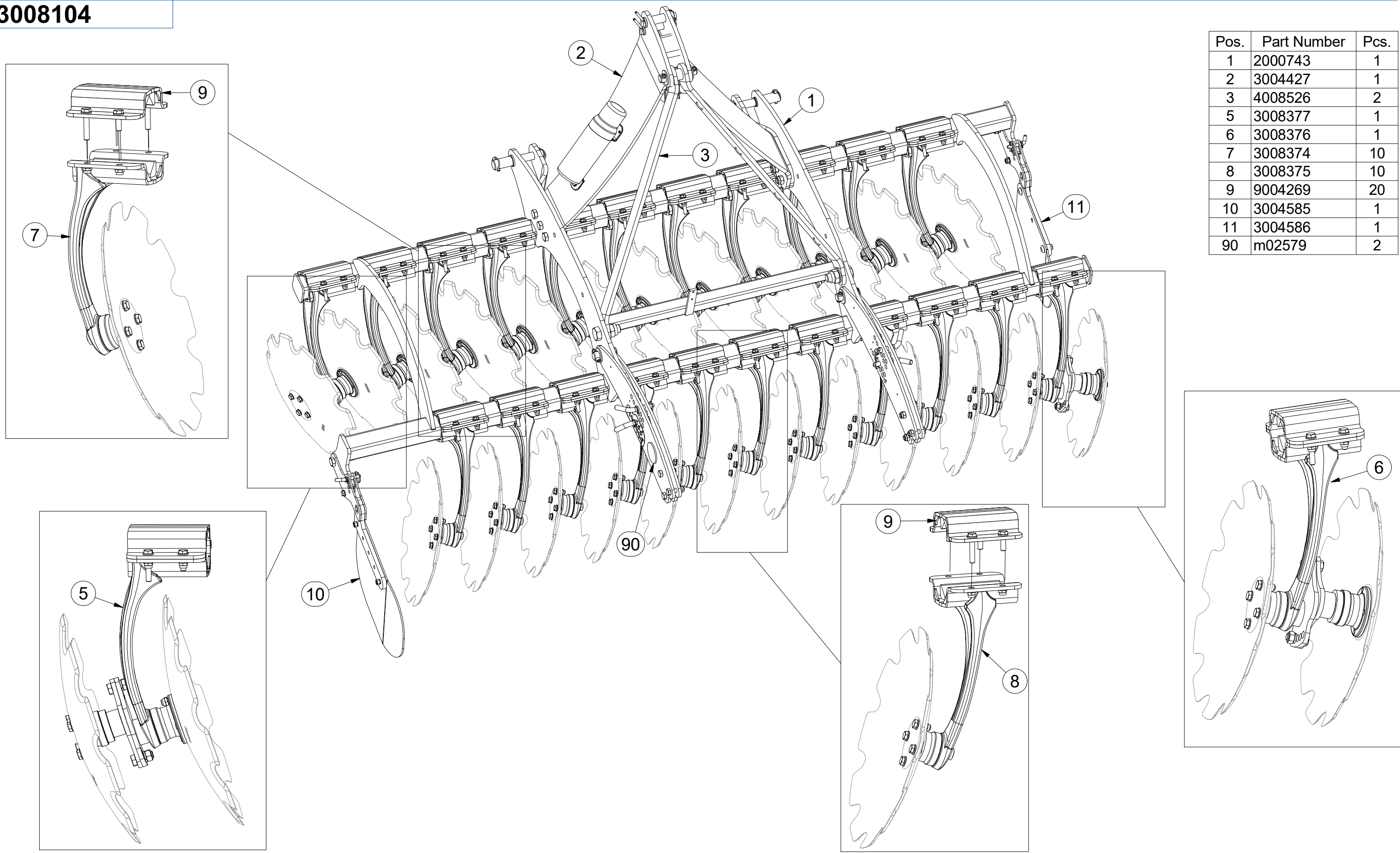

Pos.	Part Number	Pcs.
1	2000743	1
2	3004427	1
3	4008526	2
5	3008377	1
6	3008376	1
7	3008374	10
8	3008375	10
9	9004269	20
10	3004585	1
11	3004586	1
90	m02579	2

Ⓒ ZÁKLAD STROJE

Ⓓ UNTERBAU DER MASCHINE

Ⓕ BÂTI DE LA MACHINE

Ⓖ FOOTING OF THE MACHINE

Ⓡ ОСНОВАНИЕ МАШИНЫ

Ⓢ PODSTAWA MASZYNY



3008104

Pos.	Part Number	Pcs.	Pos.	Part Number	Pcs.
1	2000743	1	46	m01096	2
2	3004427	1	50	m03775	6
3	4008526	2	51	m03683	6
13	4014423	1	52	m05648	6
14	4014424	1	53	m08036	2
20	9002771	1	54	m05560	2
25	4008278	2	55	m04503	2
26	4012363	1	60	m14029	6
27	4008499	2	61	m02866	2
28	4006044	1	62	m01203	4
29	4006045	1	70	m10312	4
30	4018093	1	71	m16313	6
40	m14143	6	72	m10454	4
41	m11724	6	73	4017136	4
42	m12272	6	75	m11783	3
43	m12209	2	77	m14604	4
44	m13546	4	100	m15900	1
45	m01074	2			

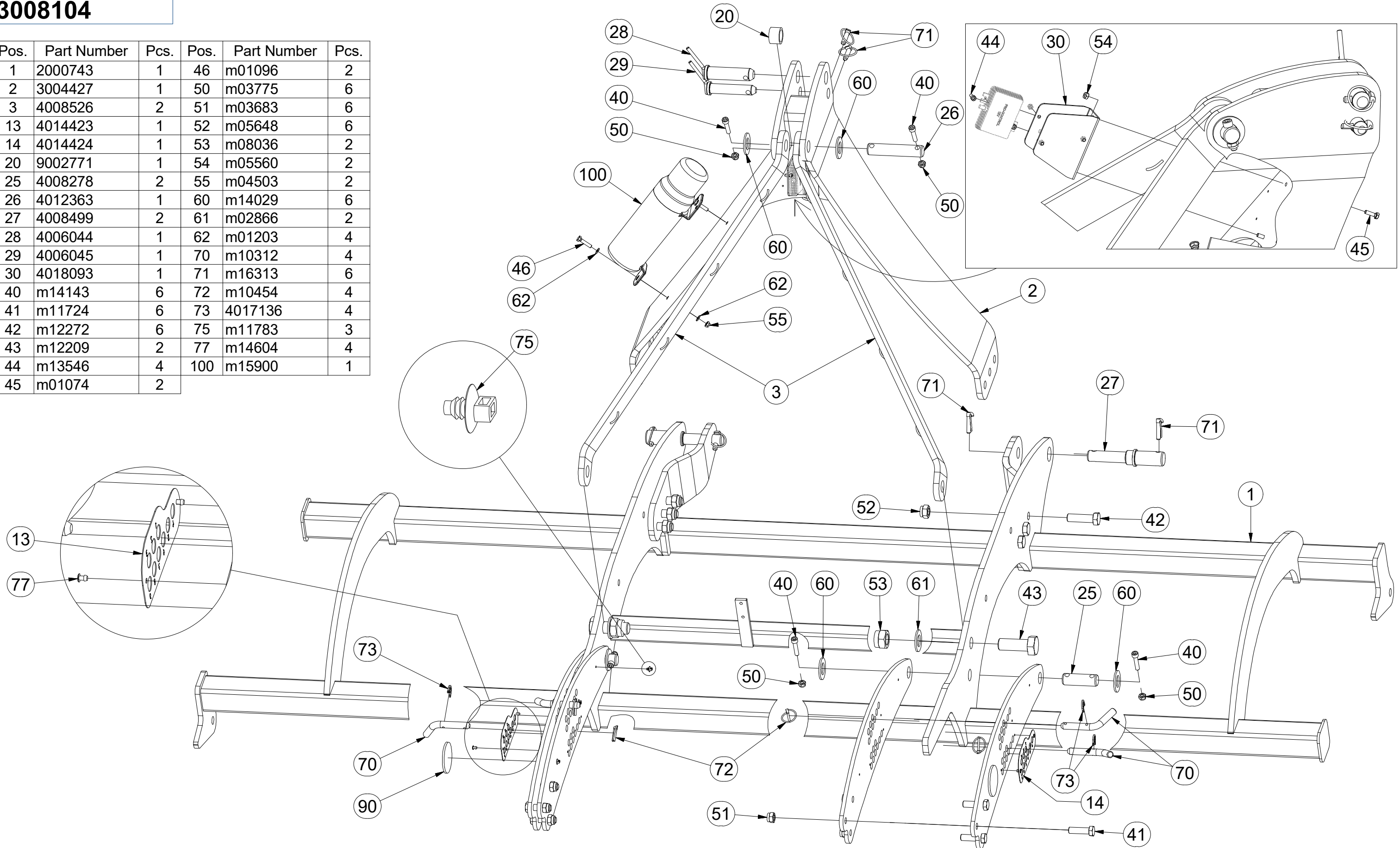

CZ ZÁVAŽÍ
 D GEWICHT
 F CONTREPOIDS

GB WEIGHT
 RU ГРУЗ
 PL OBCIĄŻNIK



3004571

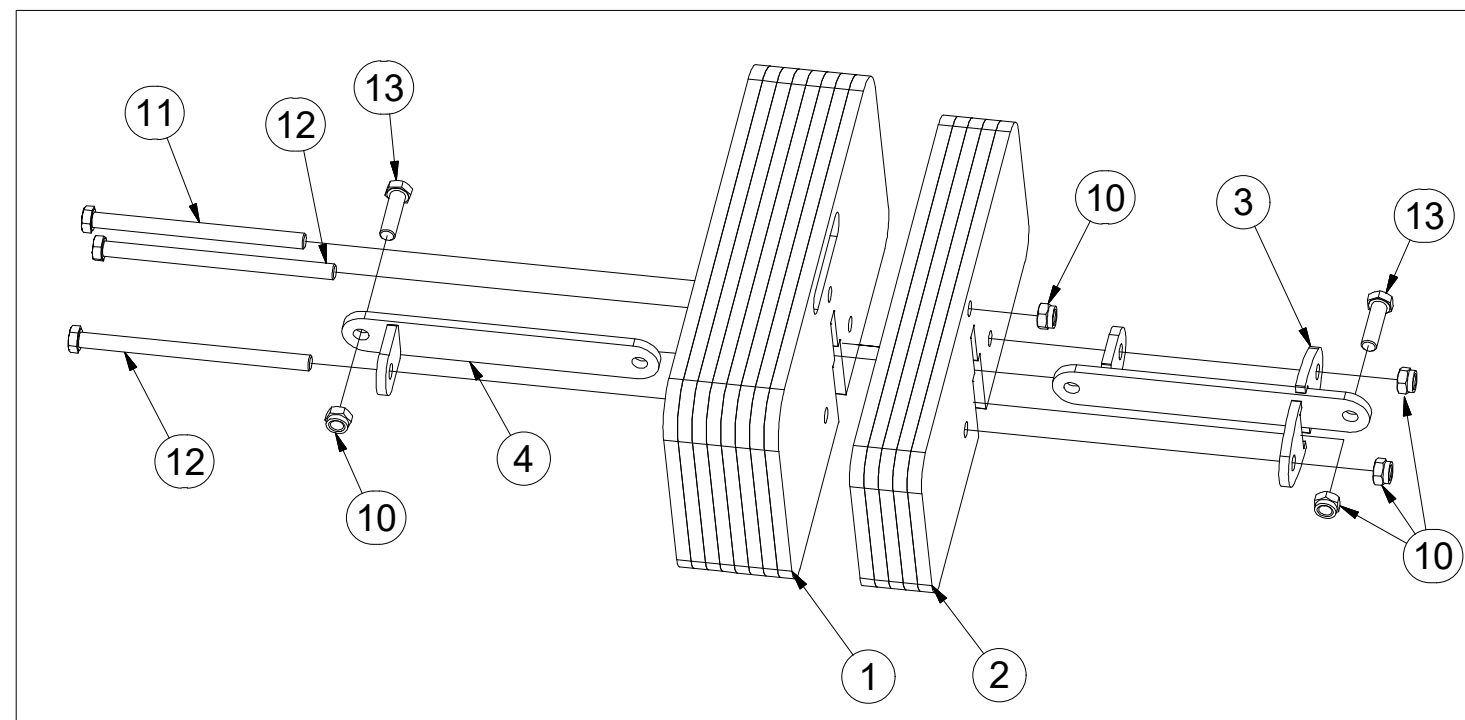
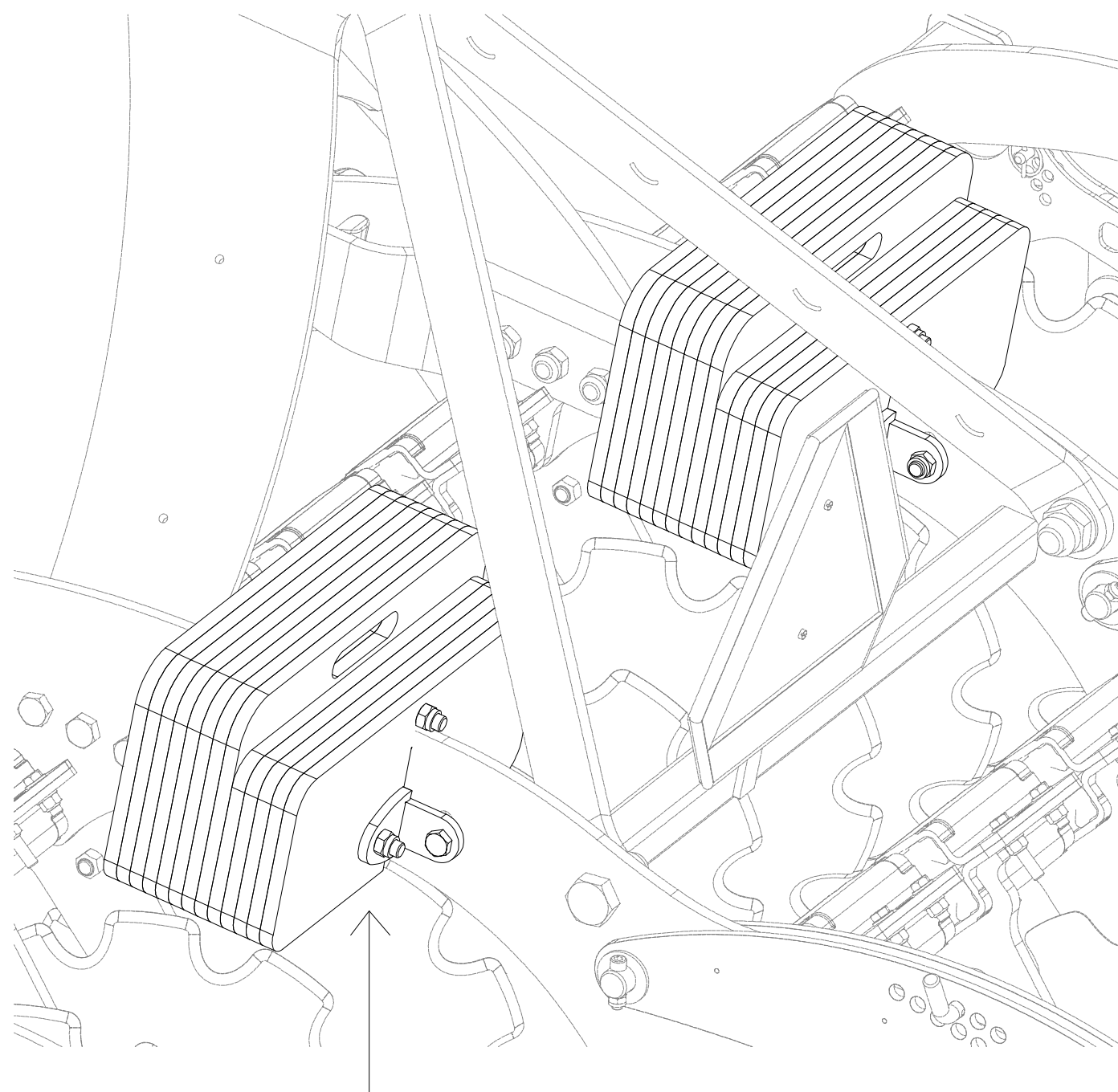

Pos.	Part Number	Pcs.
1	4008706	16
2	4008707	10
3	4008708	4
4	4008709	4
10	m03683	10
11	m05929	2
12	m09866	4
13	m10112	4

(CZ) PŘEDNÍ DISK
 (D) SCHEIBE, VORDERE
 (F) DISQUE AVANT

(GB) FRONT DISC
 (RU) ДИСК ПЕРЕДНИЙ
 (PL) TALERZ PRZEDNI



3008374

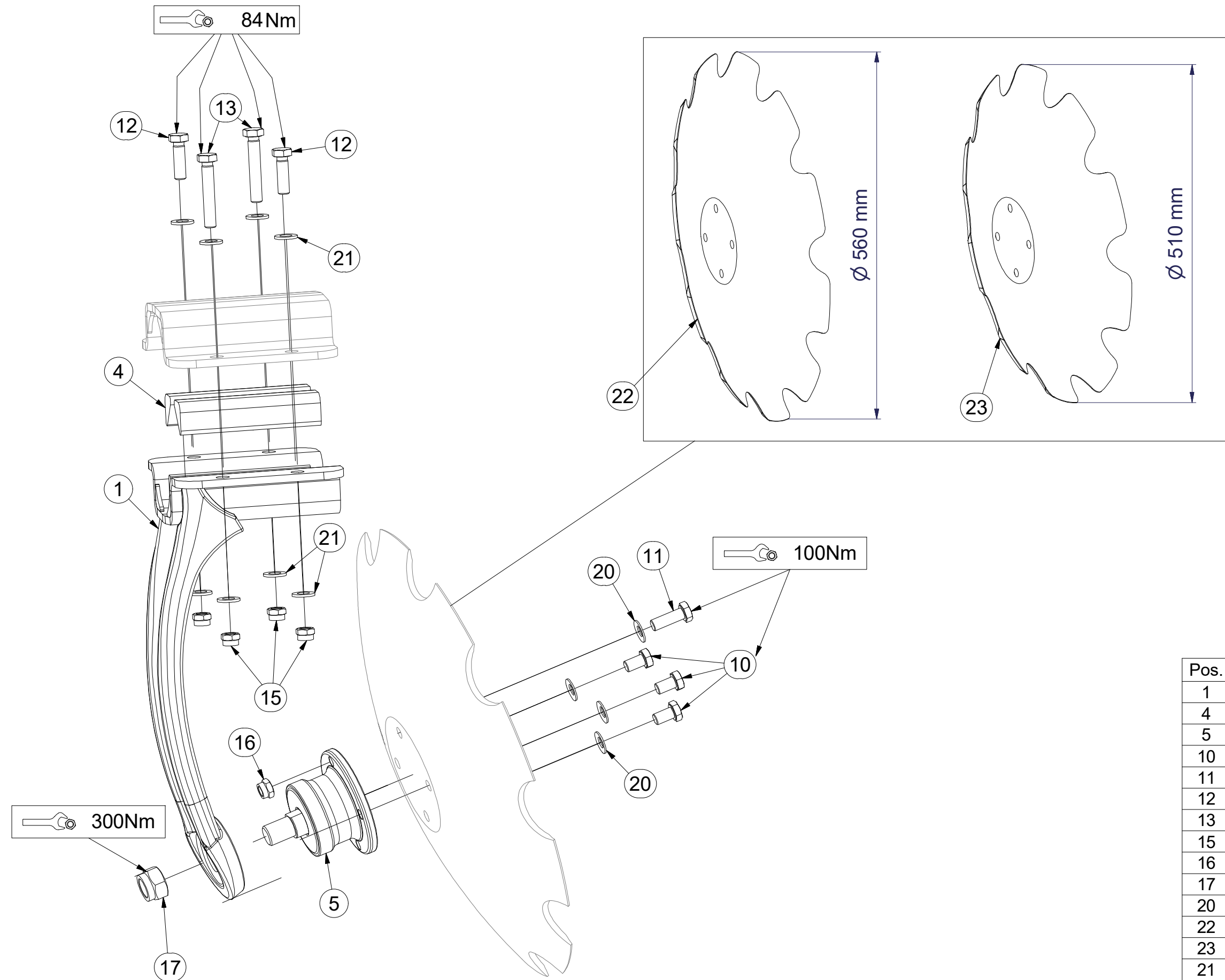

Pos.	Part Number	Pcs.
1	3008382	1
4	m16878	4
5	m11308	1
10	m11309	3
11	m11559	1
12	m17657	2
13	m17653	2
15	m12134	4
16	m11560	1
17	m11313	1
20	m17545	4
22	3006559	1
23	3007653	1
21	m17741	8

Ⓒ ZADNÍ DISK

Ⓓ SCHEIBE, HINTERE

Ⓕ DISQUE ARRIÈRE

Ⓒ REAR DISC

Ⓓ ДИСК ЗАДНИЙ

Ⓕ TALERZ TYLNY



3008375

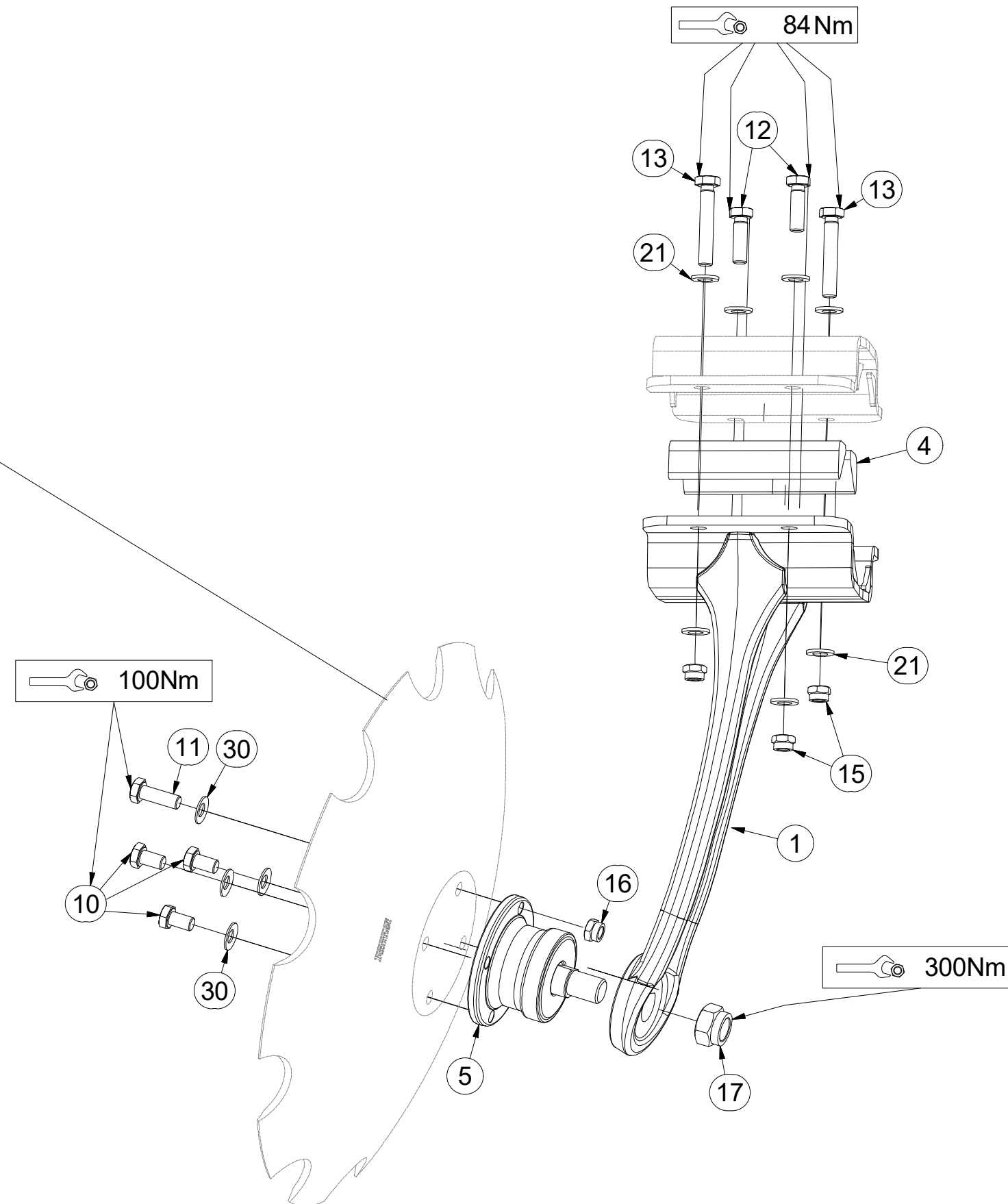
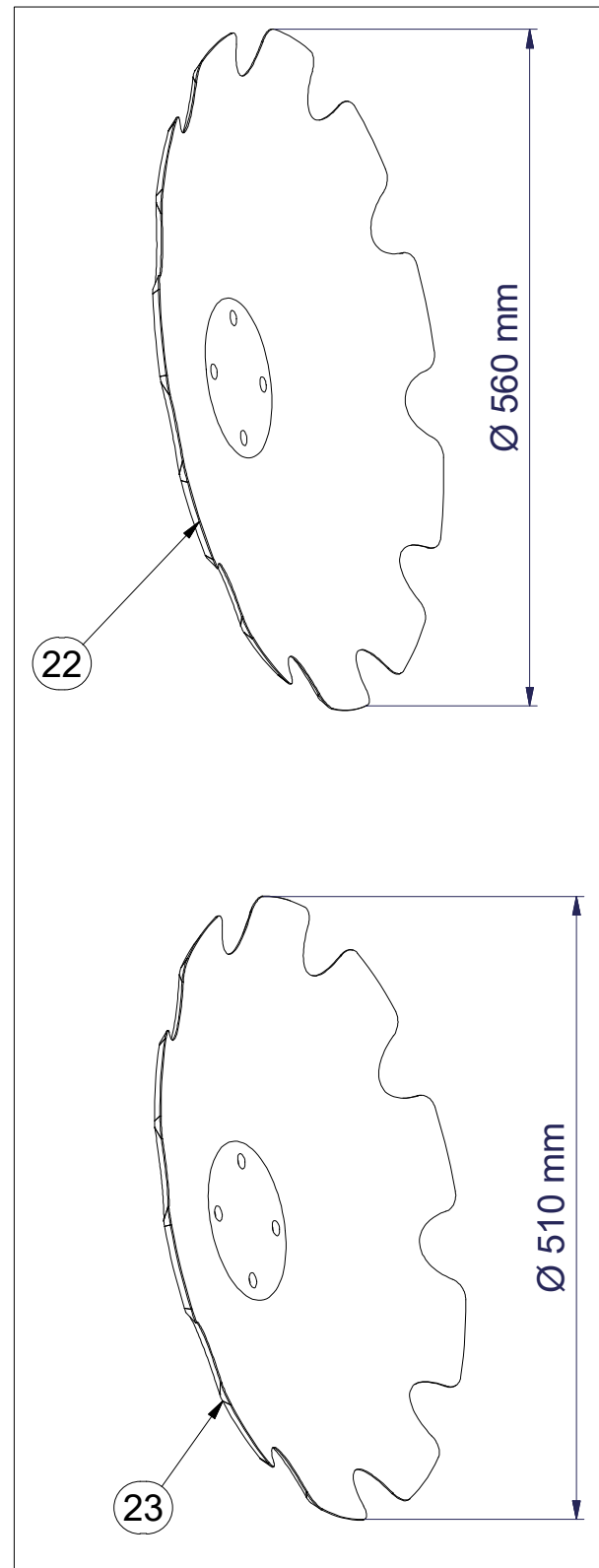

Pos.	Part Number	Pcs.
1	3008383	1
4	m16878	4
5	m11308	1
10	m11309	3
11	m11559	1
12	m17657	2
13	m17653	2
15	m12134	4
16	m11560	1
17	m11313	1
21	m17741	8
22	3006559	1
23	3007653	1
30	m17545	4

Ⓒ ZADNÍ DVOUDISK

Ⓓ DUPLEXSCHEIBE, HINTERE

Ⓕ ARRIÈRE DISQUE DOUBLE

Ⓖ REAR TWIN DISC

Ⓔ ДВОЙНОЙ ДИСК ЗАДНИЙ

Ⓗ TALERZ PODWÓJNY TYLNY



3008376

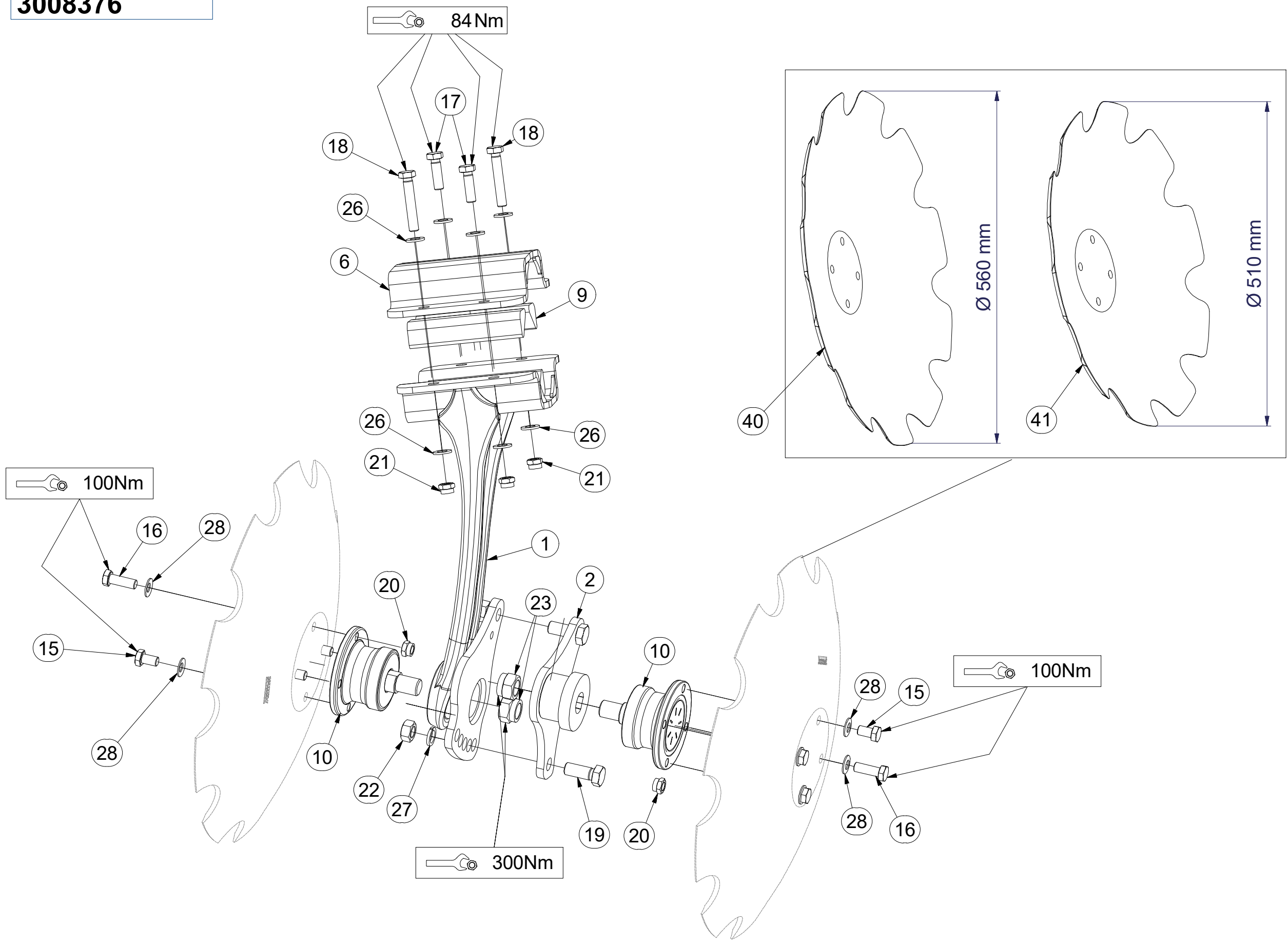

Pos.	Part Number	Pcs.
1	3008384	1
2	4014367	1
6	9004269	1
9	m16878	4
10	m11308	2
15	m11309	6
16	m11559	2
17	m17657	2
18	m17653	2
19	m01129	2
20	m11560	2
21	m12134	4
22	m01306	2
23	m11313	2
26	m17741	8
27	m02157	2
28	m17545	8
40	3006559	2
41	3007653	2

ⒸZ PŘEDNÍ DVOJDISK

Ⓓ DUPLEXSCHEIBE, VORDERE

Ⓕ AVANT DISQUE DOUBLE

ⒸB FRONT TWIN DISC

ⒸU ДВОЙНОЙ ДИСК ПЕРЕДНИЙ

ⒸL TALERZ PODWÓJNY PRZEDNI



3008377

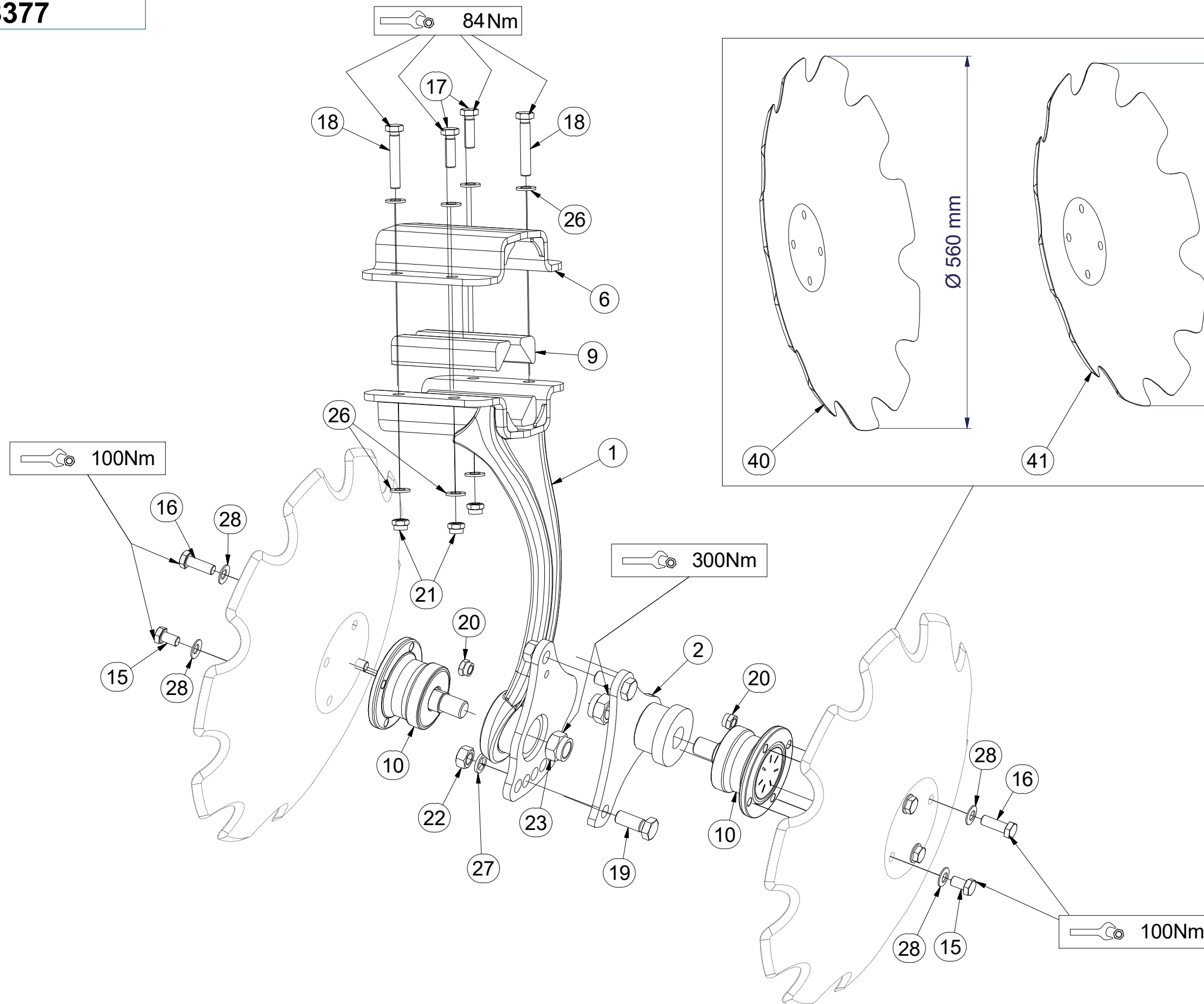

Pos.	Part Number	Pcs.
1	3008385	1
2	4014426	1
6	9004269	1
9	m16878	4
10	m11308	2
15	m11309	6
16	m11559	2
17	m17657	2
18	m17653	2
19	m01129	2
20	m11560	2
21	m12134	4
22	m01306	2
23	m11313	2
26	m17741	8
27	m02157	2
28	m17545	8
40	3006559	2
41	3007653	2

CZ ZADNÍ DEFLEKTOR
 D DEFLEKTOR, HINTERE
 F DÉFLECTEUR ARRIÈRE

GB REAR DEFLECTOR
 RU ЗАДНИЙ ДЕФЛЕКТОР
 PL DEFLEKTOR TYLNY



3004585

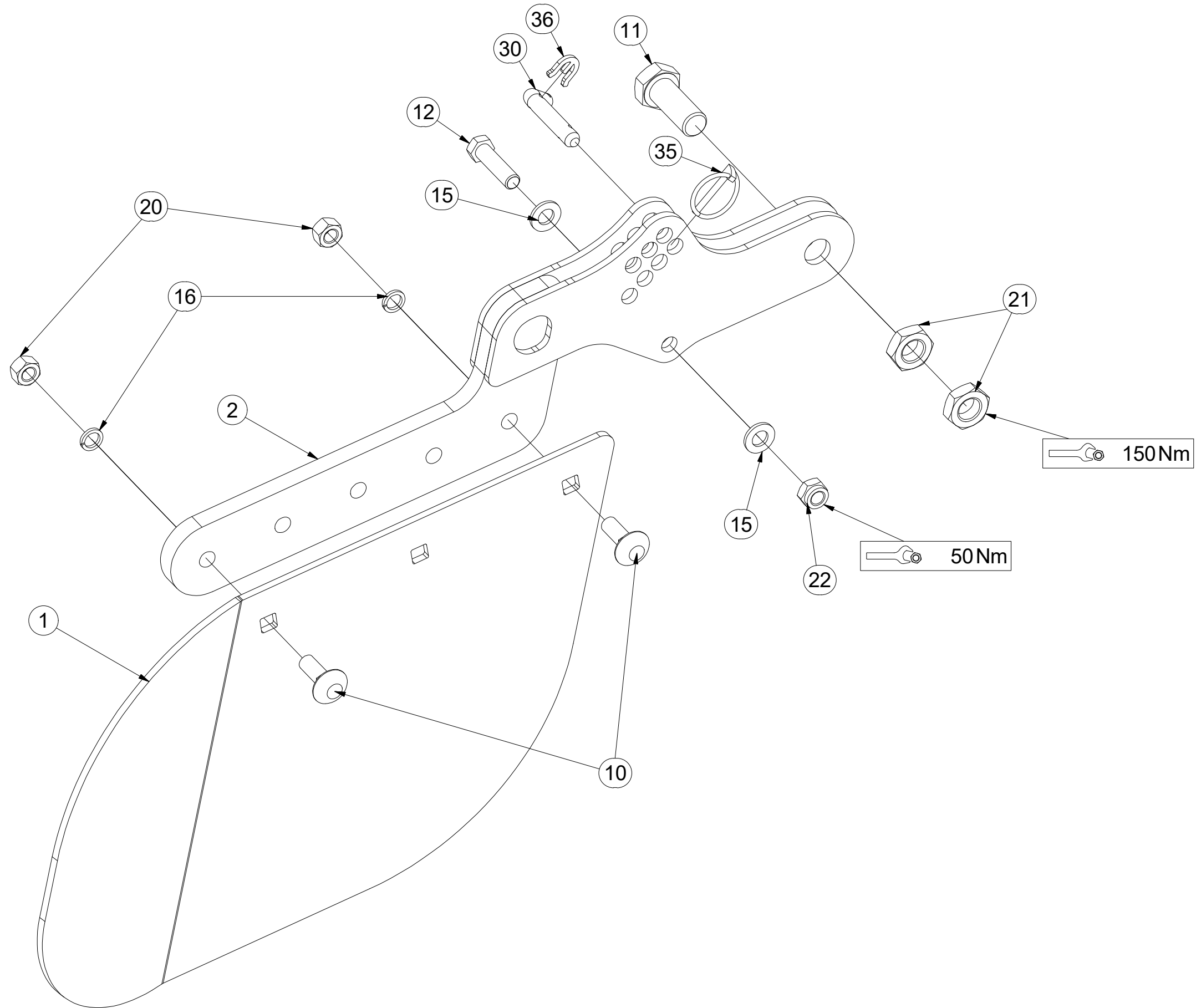

Pos	Part Number	Pcs.
1	4007854	1
2	4008743	1
10	m10618	2
11	m08378	1
12	m06077	1
15	m01214	2
16	m03988	2
20	m10439	2
21	m04284	2
22	m04301	1
30	m09141	1
35	m10454	1
36	4016279	1

CZ PŘEDNÍ DEFLEKTOR
 D DEFLEKTOR, VORDERE
 F DÉFLECTEUR AVANT

GB FRONT DEFLECTOR
 RU ПЕРЕДНИЙ ДЕФЛЕКТОР
 PL DEFLOKTOR PRZEDNI



3004586

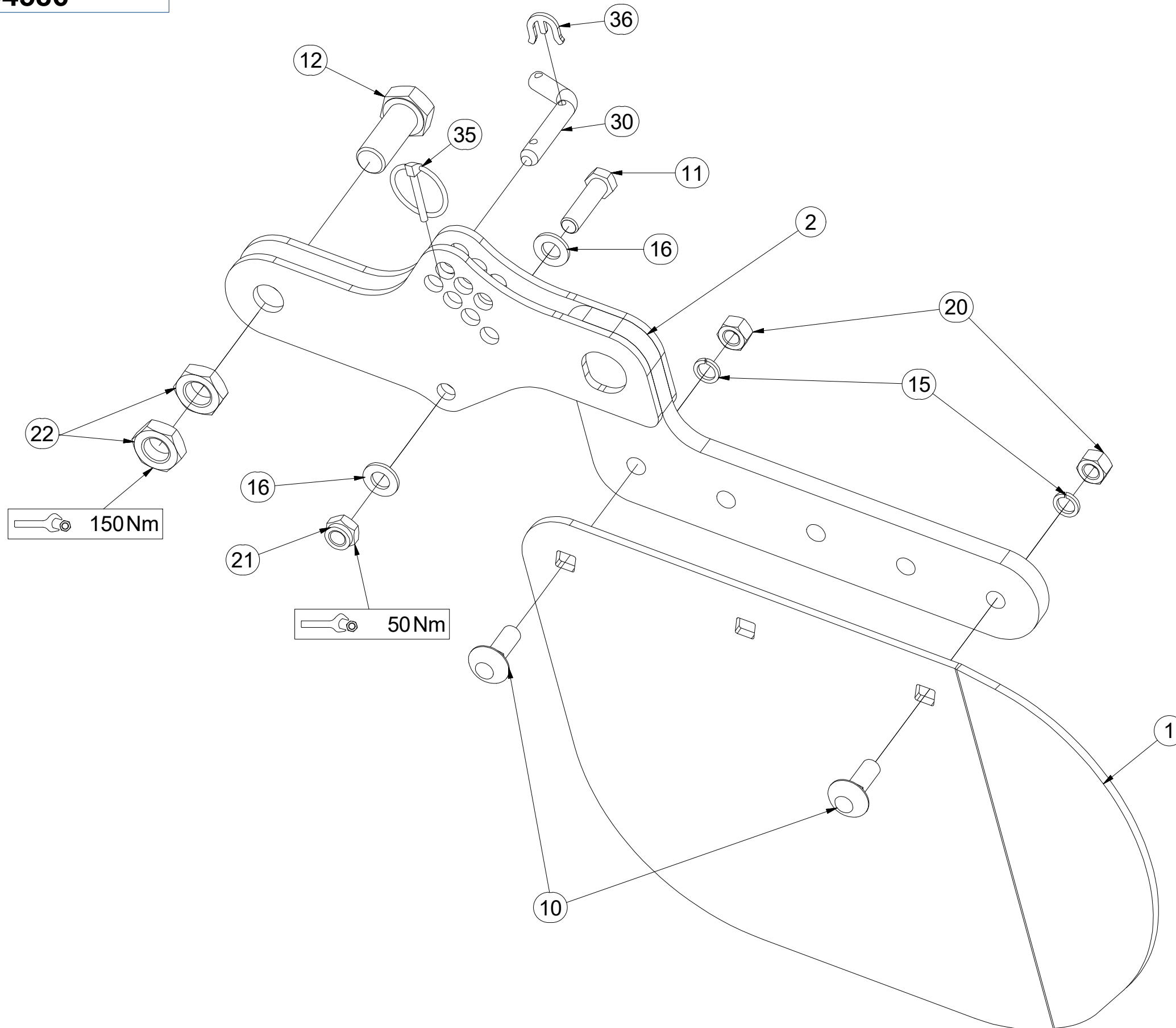

Pos	Part Number	Pcs.
1	4008155	1
2	4008743	1
10	m10618	2
11	m06077	1
12	m08378	1
15	m03988	2
16	m01214	2
20	m10439	2
21	m04301	1
22	m04284	2
30	m09141	1
35	m10454	1
36	4016279	1

(CZ) SADA ZADNÍCH VÁLCŮ
 (D) SATZ HINTERE WALZEN
 (F) KIT DE ROULEAUX ARRIÈRE

(GB) SET OF REAR ROLLERS
 (RU) КОМПЛЕКТ ЗАДНИХ КАТКОВ
 (PL) ZESTAW TYLNYCH WAŁÓW



3010398

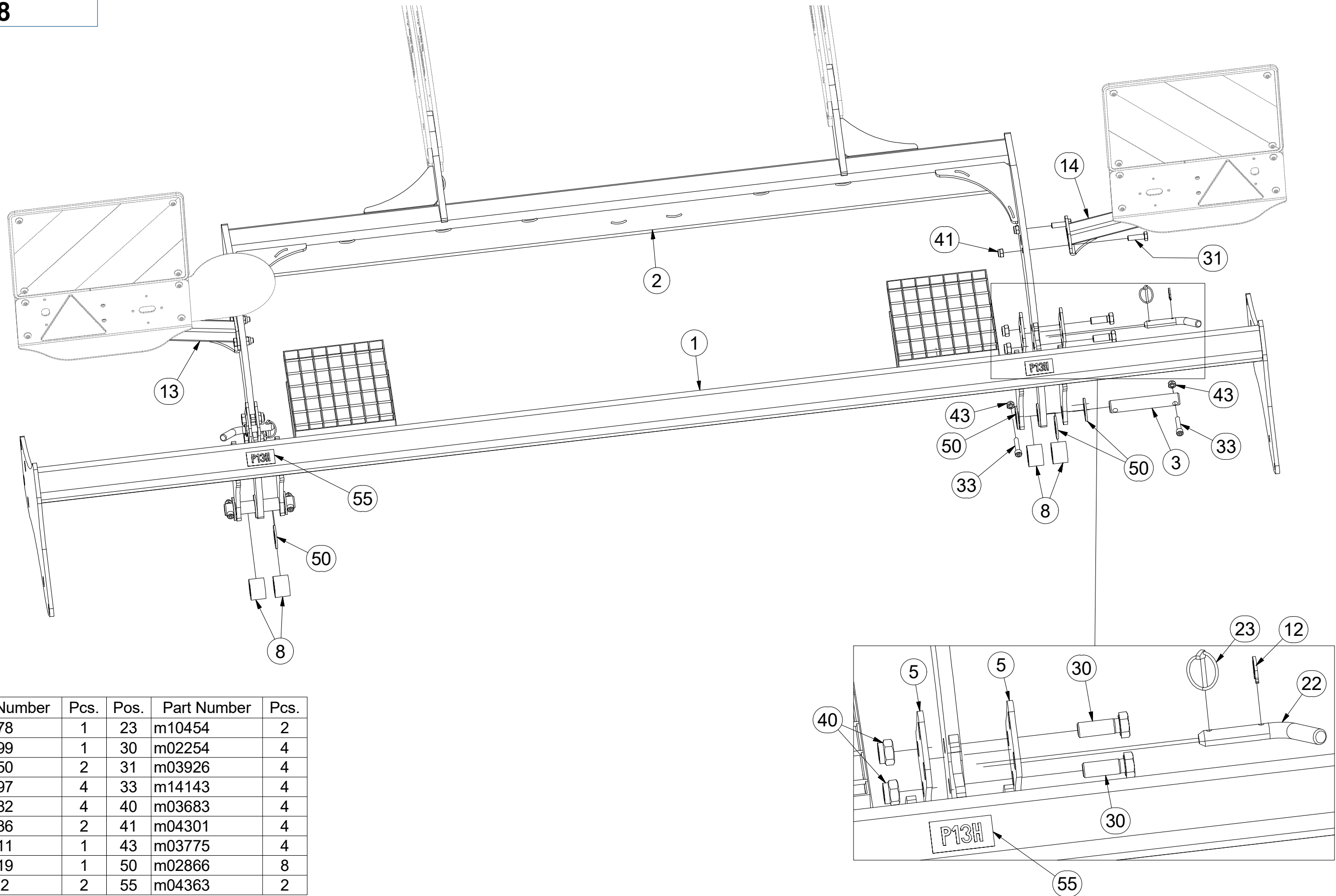

Pos.	Part Number	Pcs.	Pos.	Part Number	Pcs.
1	3003278	1	23	m10454	2
2	3010399	1	30	m02254	4
3	4011050	2	31	m03926	4
5	4008497	4	33	m14143	4
8	9002782	4	40	m03683	4
12	4017136	2	41	m04301	4
13	3009811	1	43	m03775	4
14	3009819	1	50	m02866	8
22	m10312	2	55	m04363	2

CZ SADA ZADNÍCH VÁLCŮ
 D SATZ HINTERE WALZEN
 F KIT DE ROULEAUX ARRIÈRE

GB SET OF REAR ROLLERS
 RU КОМПЛЕКТ ЗАДНИХ КАТКОВ
 PL ZESTAW TYLNYCH WAŁÓW



3010398

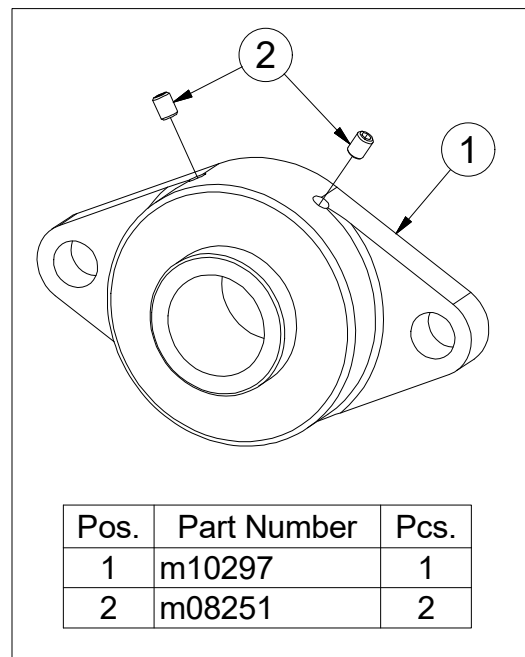
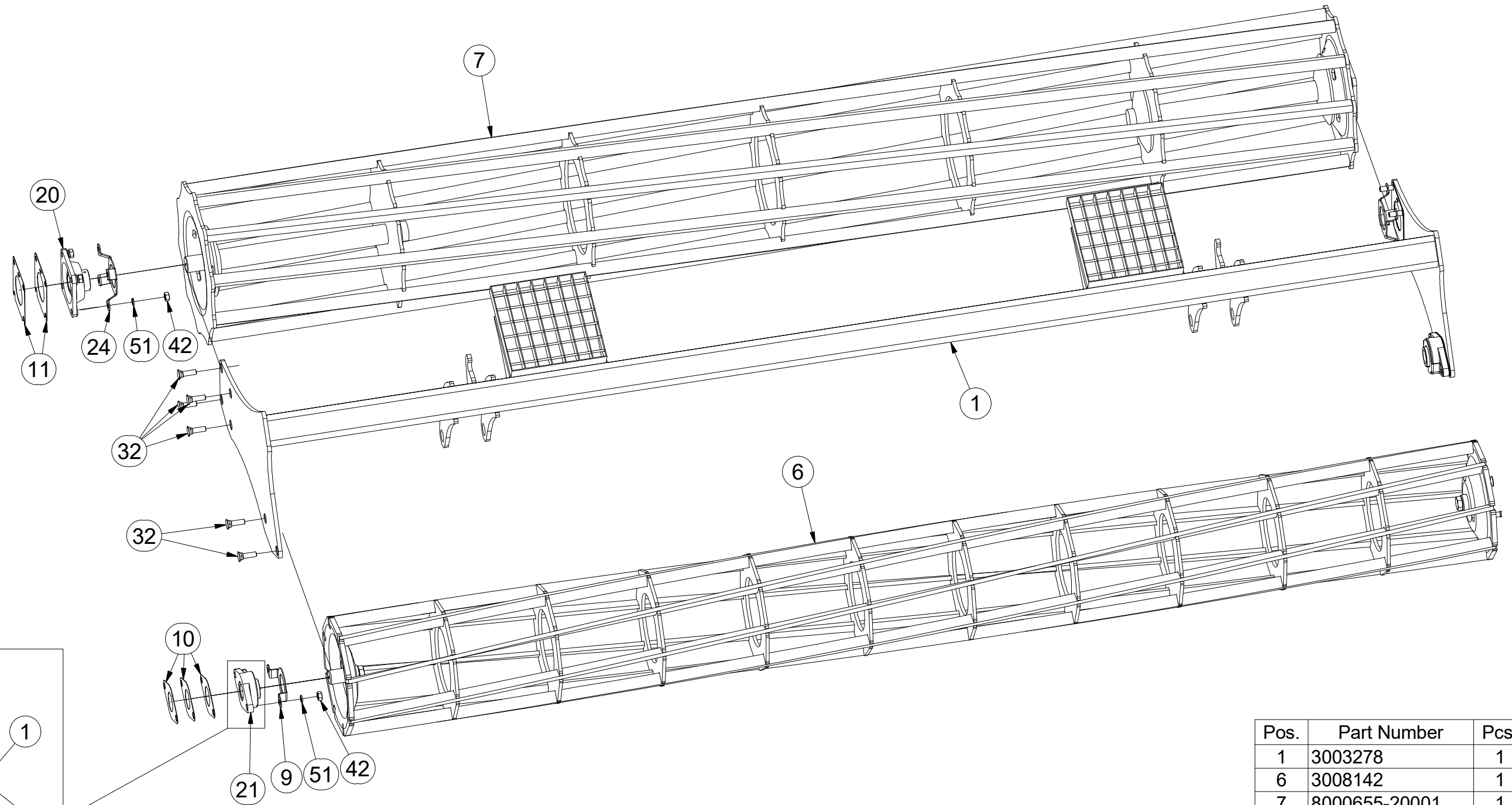

Pos.	Part Number	Pcs.
1	3003278	1
6	3008142	1
7	8000655-20001	1
9	4017643	2
10	4017638	6
11	4016809	4
20	m12965	2
21	10297B	2
24	m12337	2
32	m03519	12
42	m01305	12
51	m03988	12

CZ TERČE
 D SCHEIBE
 F CIBLES

GB DISCS
 RU ЩИТКИ
 PL TARCZE



3010378

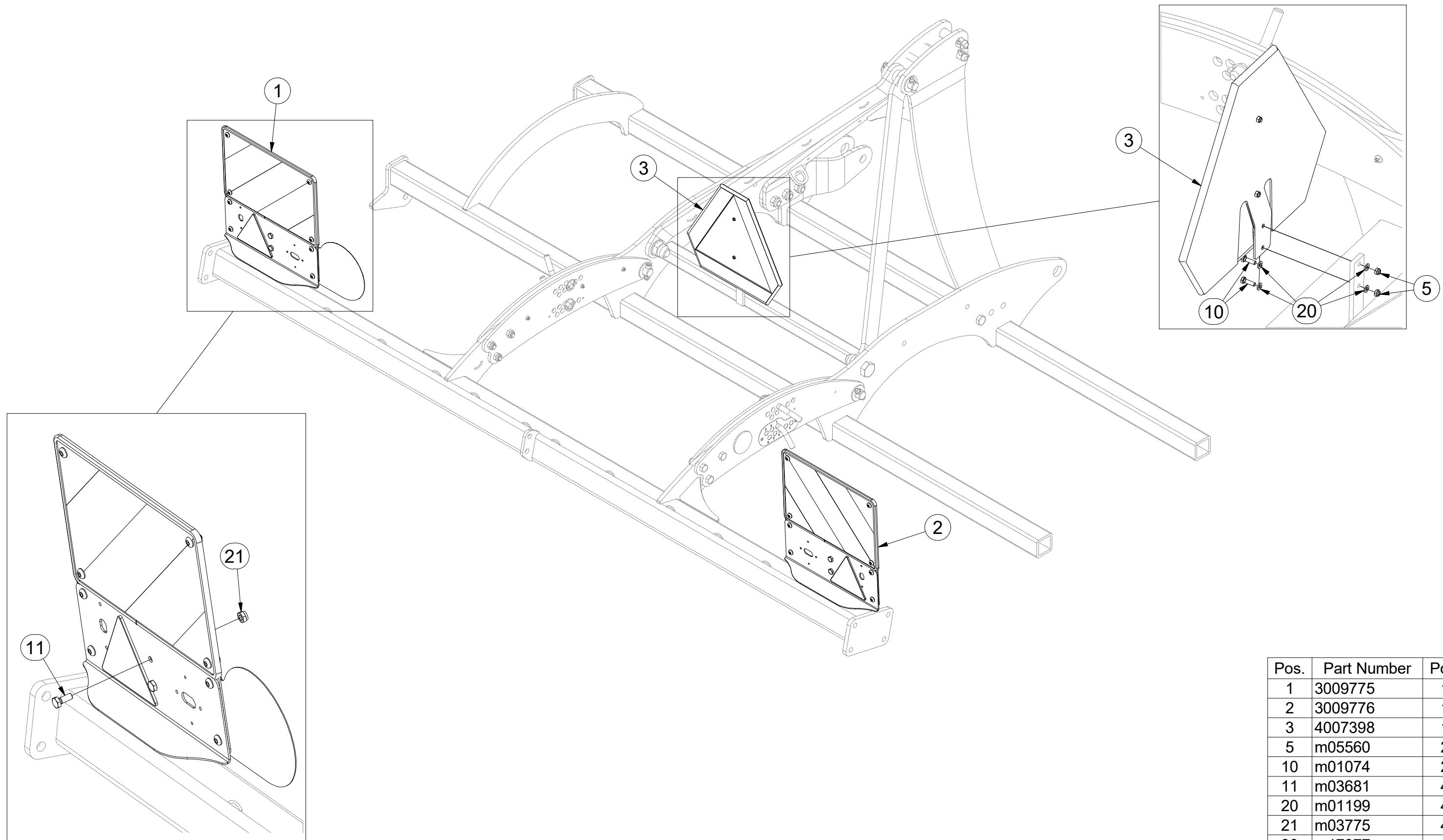

Pos.	Part Number	Pcs.
1	3009775	1
2	3009776	1
3	4007398	1
5	m05560	2
10	m01074	2
11	m03681	4
20	m01199	4
21	m03775	4
30	m17377	1

ⒸZ TERČ ZADNÍ LEVÝ

Ⓓ SCHILD, HINTERES, LINKES

Ⓕ CIBLE ARRIÈRE GAUCHE

ⒸB LEFT REAR DISC

ⒸU ЩИТОК ЗАДНИЙ ЛЕВЫЙ

ⒸL TARCZA TYLNA LEWA



3009775

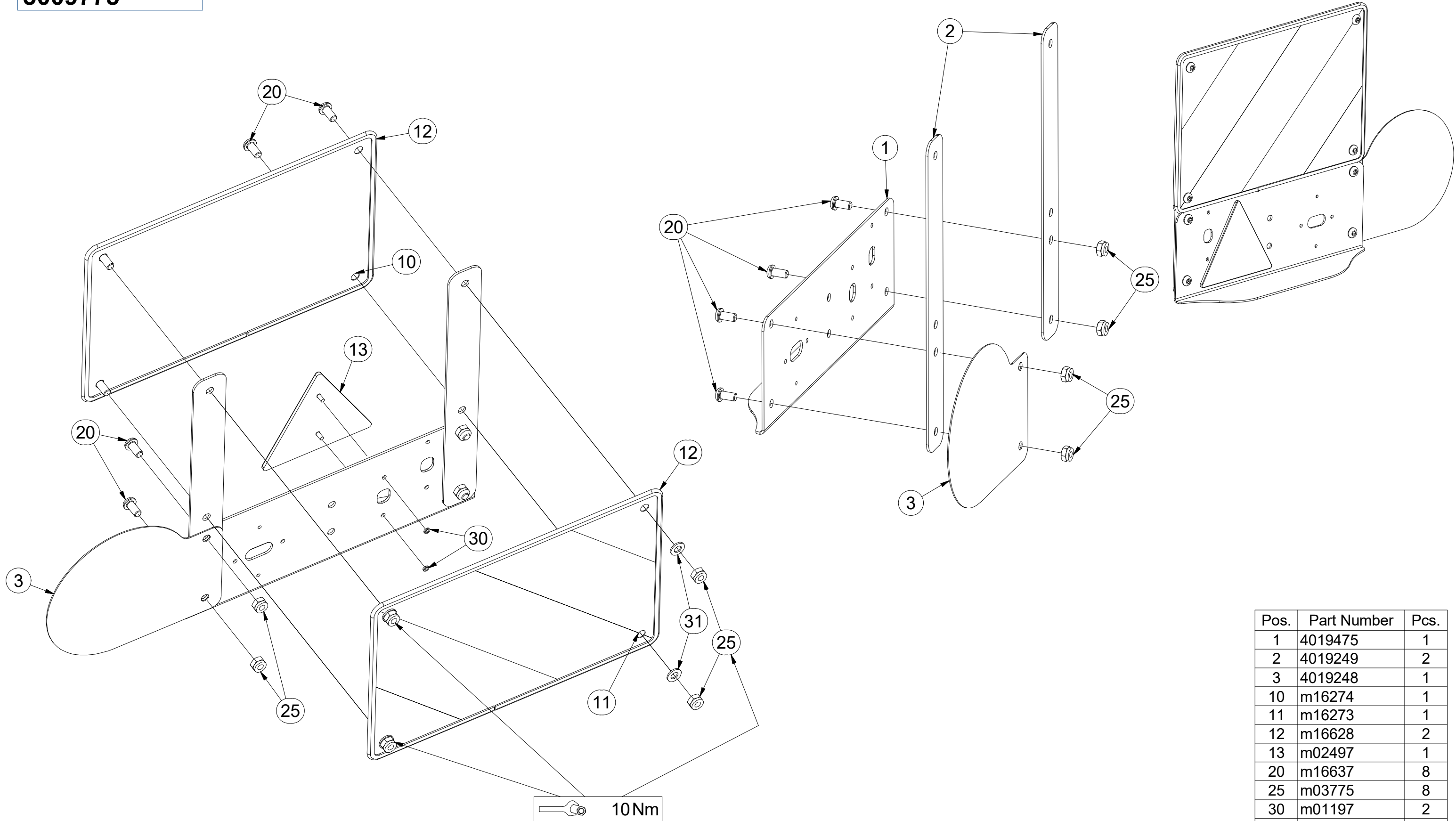

Pos.	Part Number	Pcs.
1	4019475	1
2	4019249	2
3	4019248	1
10	m16274	1
11	m16273	1
12	m16628	2
13	m02497	1
20	m16637	8
25	m03775	8
30	m01197	2
31	m01209	4

ⒸZ TERČ ZADNÍ PRAVÝ

Ⓓ SCHILD, HINTERES, RECHTES

Ⓕ CIBLE ARRIÈRE DROITE

ⒼB RIGHT REAR DISC

ⒶU ЩИТОК ЗАДНИЙ ПРАВЫЙ

ⒶL TARCZA TYLNA PRAWA



3009776

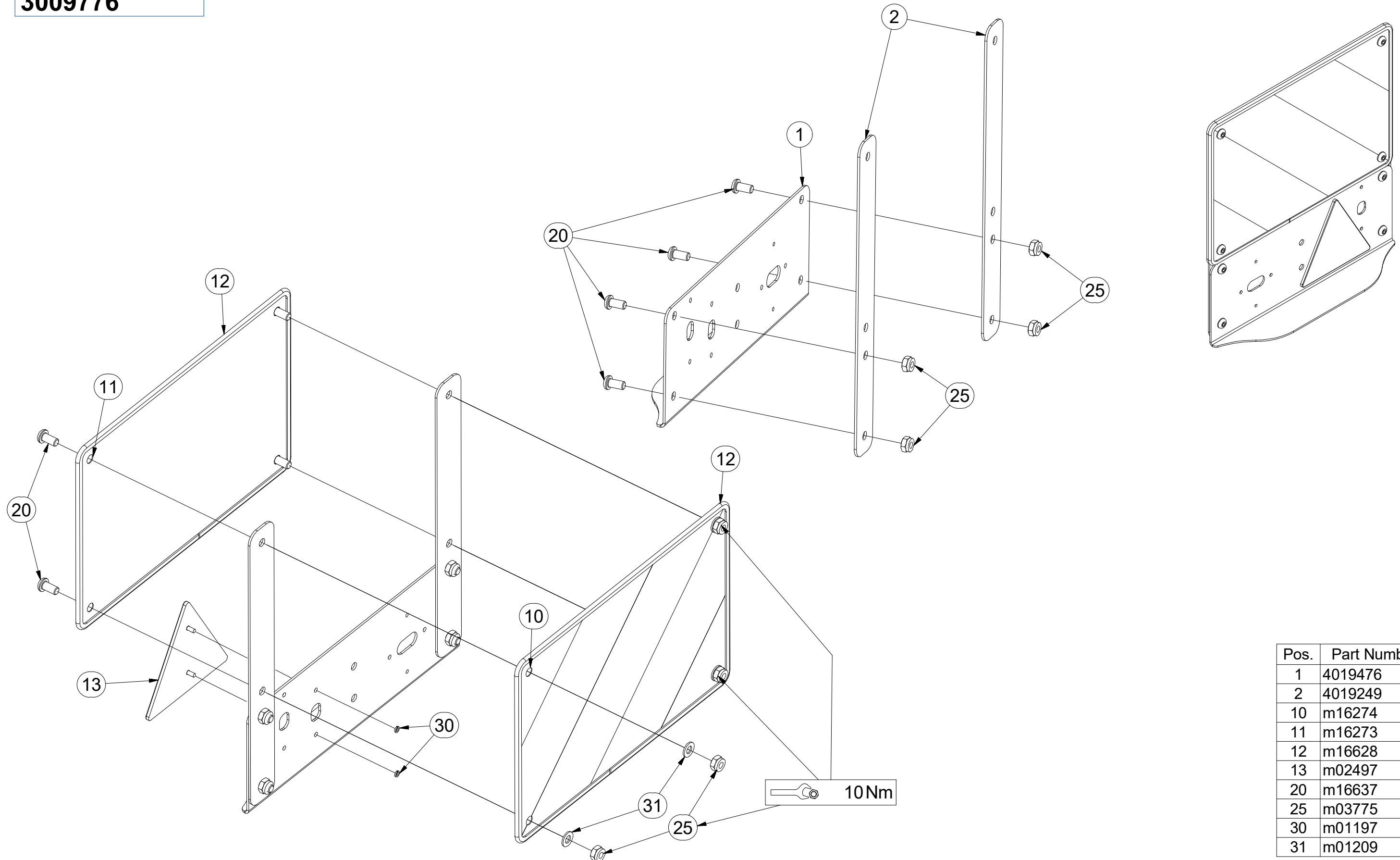

Pos.	Part Number	Pcs.
1	4019476	1
2	4019249	2
10	m16274	1
11	m16273	1
12	m16628	2
13	m02497	1
20	m16637	8
25	m03775	8
30	m01197	2
31	m01209	4

ⒸZ VÝSTRAŽNÝ TROJÚHELNÍK
Ⓓ WARNDREIECK
Ⓕ TRIANGLE D'AVERTISSEMENT

ⒸB EMERGENCY TRIANGLE
Ⓓ RU ЗНАК АВАРИЙНОЙ ОСТАНОВКИ
Ⓕ PL TRÓJKĄT OSTRZEGAWCZY



4007398

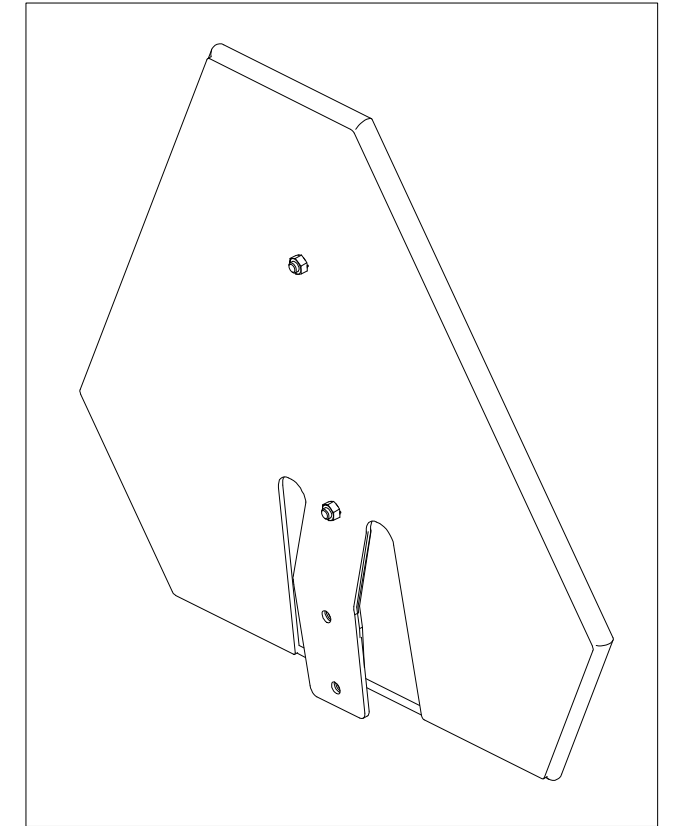
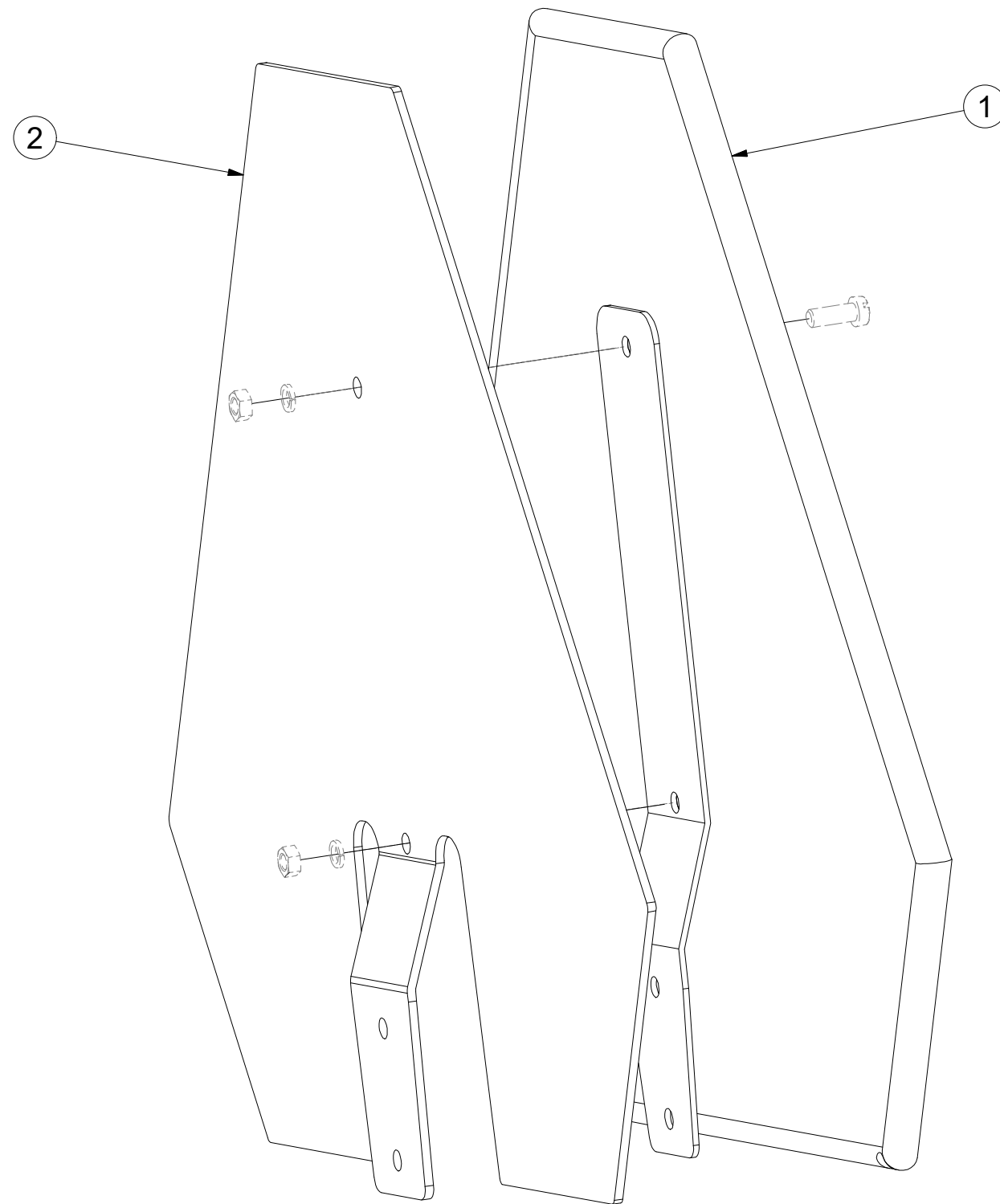

Pos.	Part Number	Pcs.
2	3003785	1
1	m05371	1

Ⓒ SVĚTELNÁ SADA

Ⓓ LEUCHTENSATZ

Ⓕ KIT LUMINEUX

Ⓒ LIGHTING SET

Ⓓ ОСВЕТИТЕЛЬНЫЙ КОМПЛЕКТ

Ⓕ ZESTAW OŚWIETLENIA



3010971

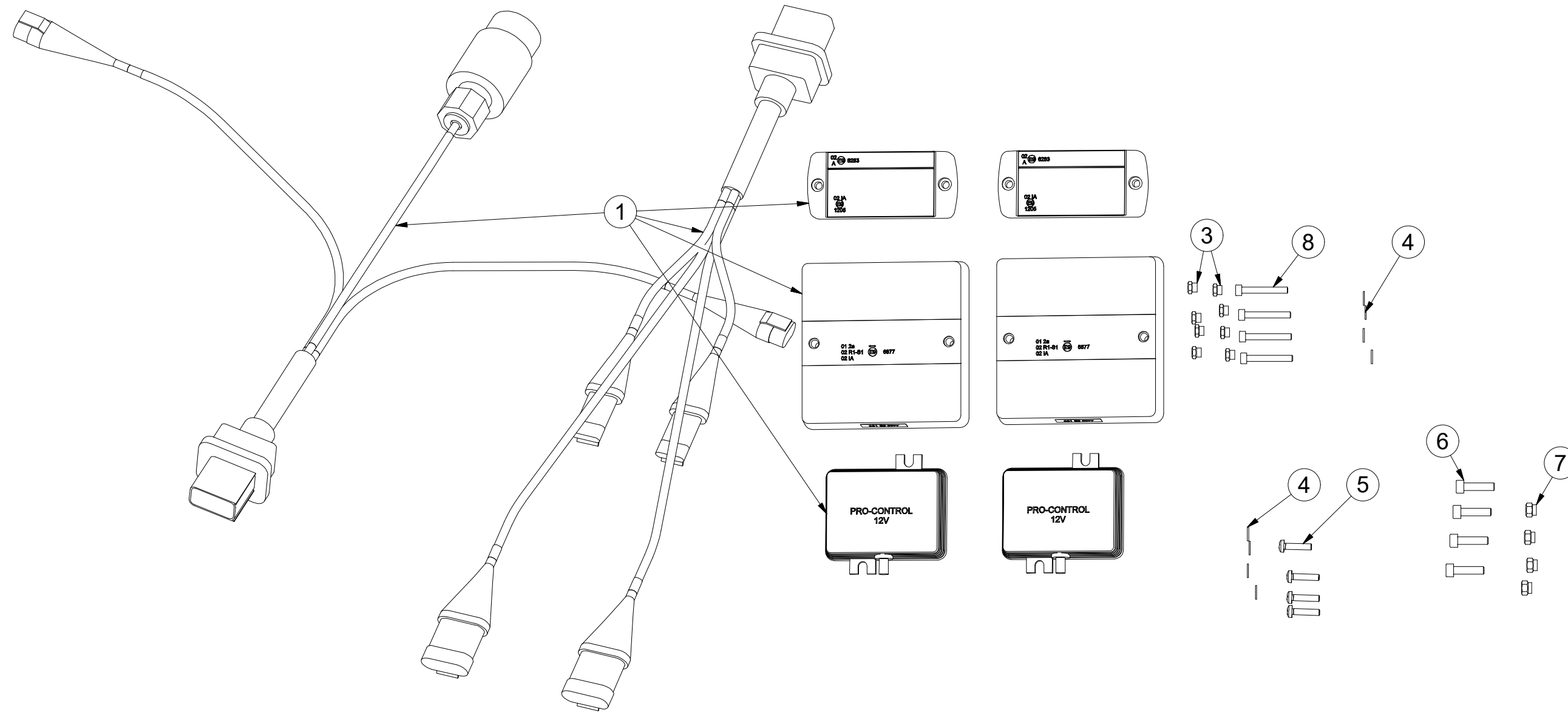

Pos.	Part Number	Pcs.
1	m17525	1
3	m05562	8
4	m05597	8
5	m15790	4
6	m10591	4
7	m06236	4
8	m16861	4

Ⓒ SVĚTELNÁ SADA

Ⓓ LEUCHTENSATZ

Ⓕ KIT LUMINEUX

Ⓖ LIGHTING SET

Ⓡ ОСВЕТИТЕЛЬНЫЙ КОМПЛЕКТ

Ⓟ ZESTAW OŚWIETLENIA



m17525

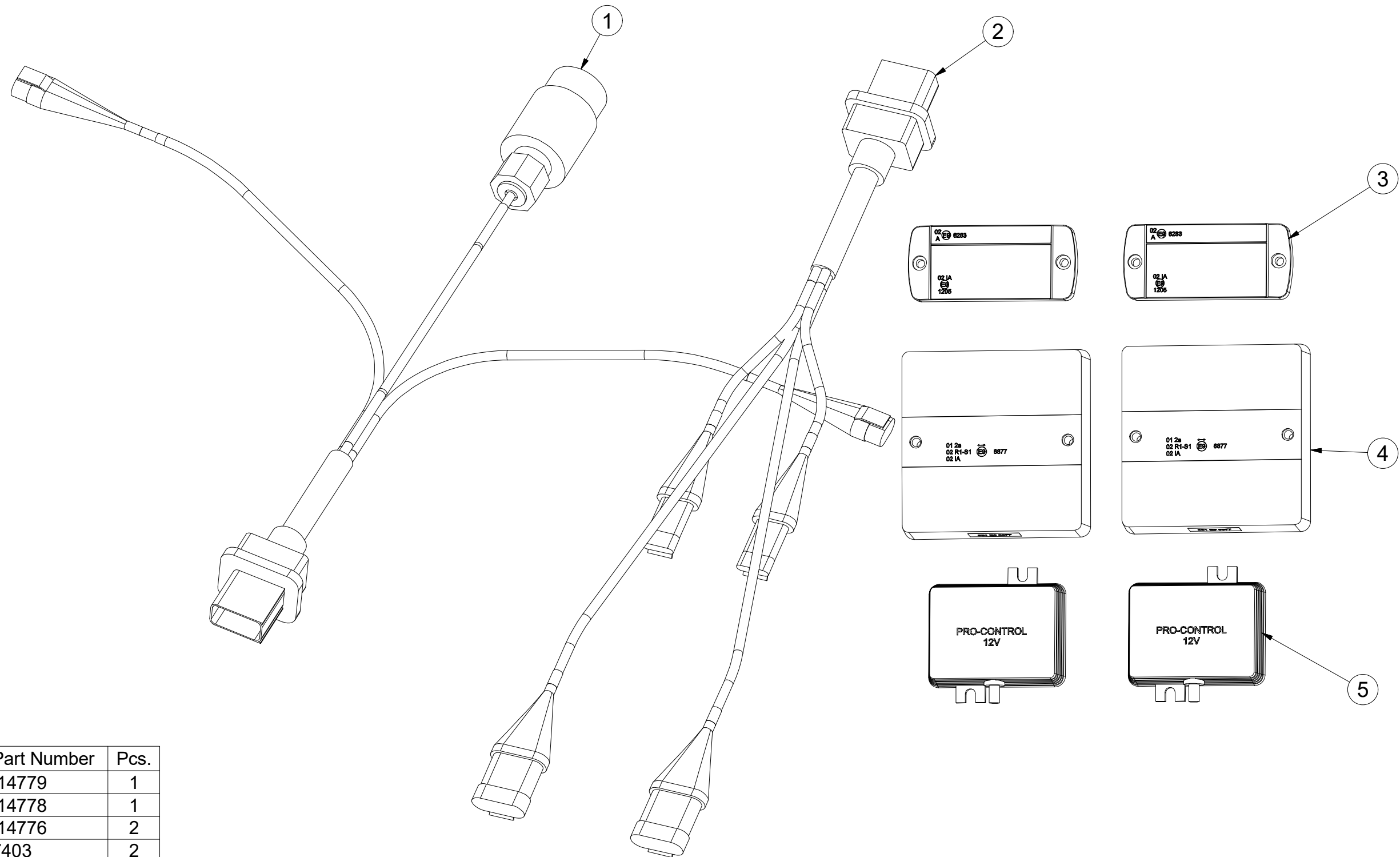

Pos.	Part Number	Pcs.
1	m14779	1
2	m14778	1
3	m14776	2
4	17403	2
5	m14777	2

☉ SAMOLEPKY STROJE

☉ AUFKLEBER MASCHINEN

☉ VOITURE MACHINES

☉ STICKERS MACHINES

☉ СТИКЕРЫ МАШИНЫ

☉ NAKLEJKI MASZYNY



8000789-30061

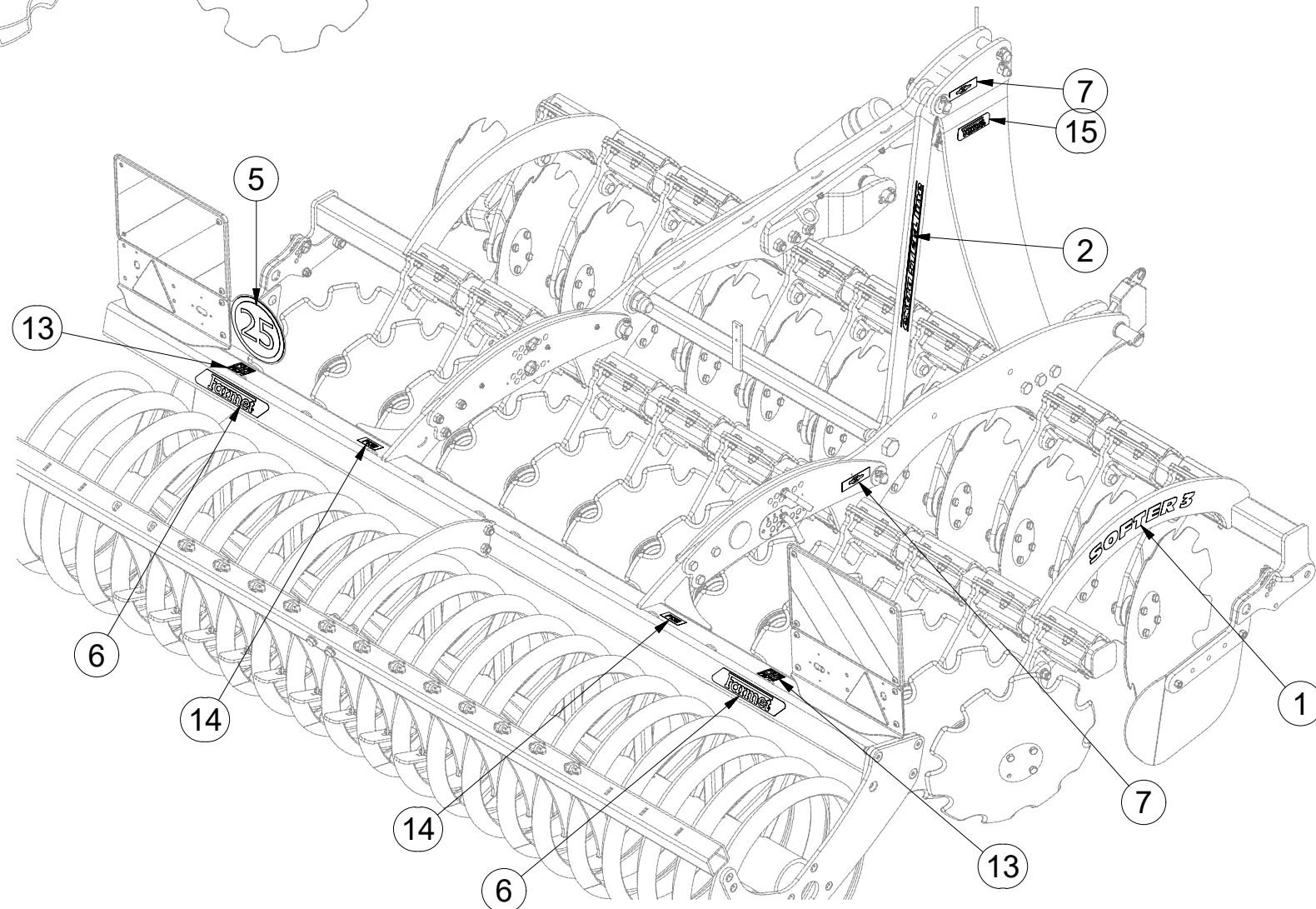
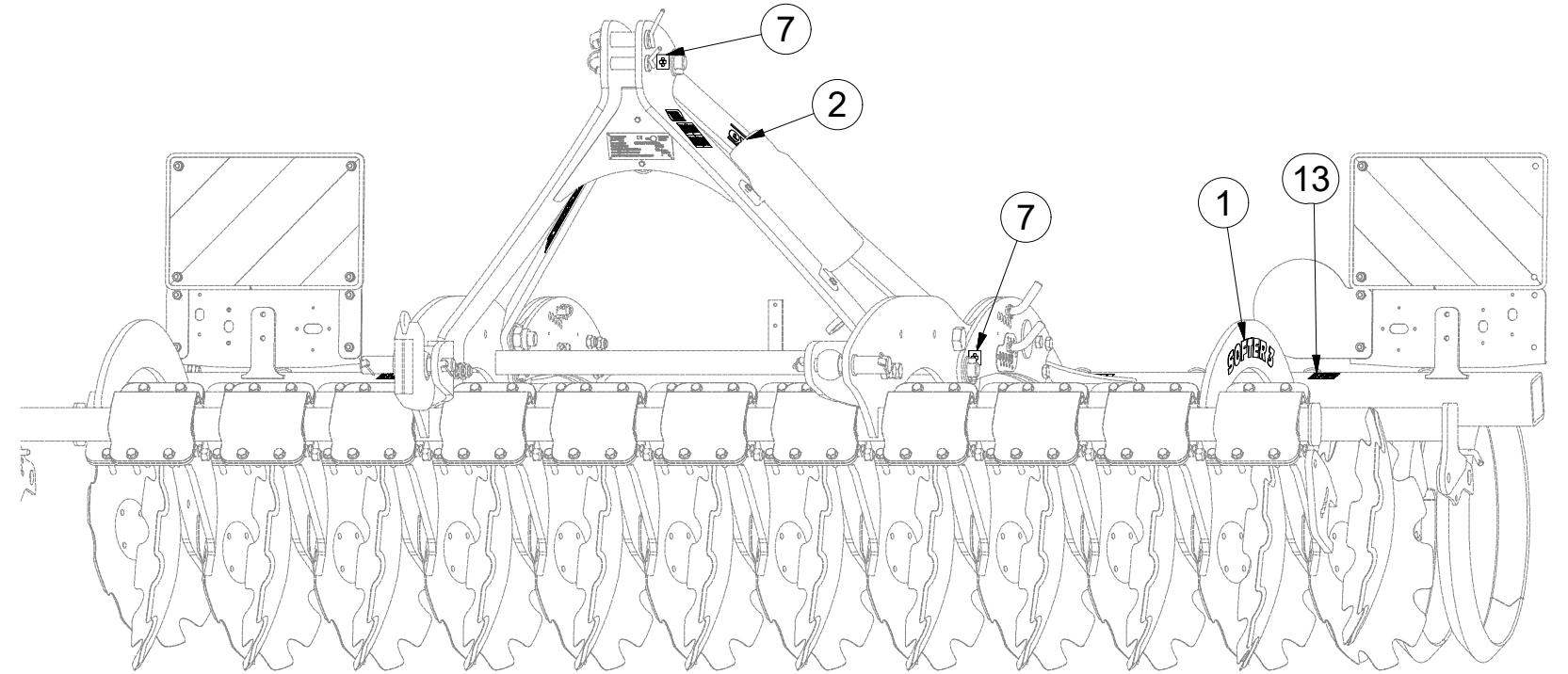
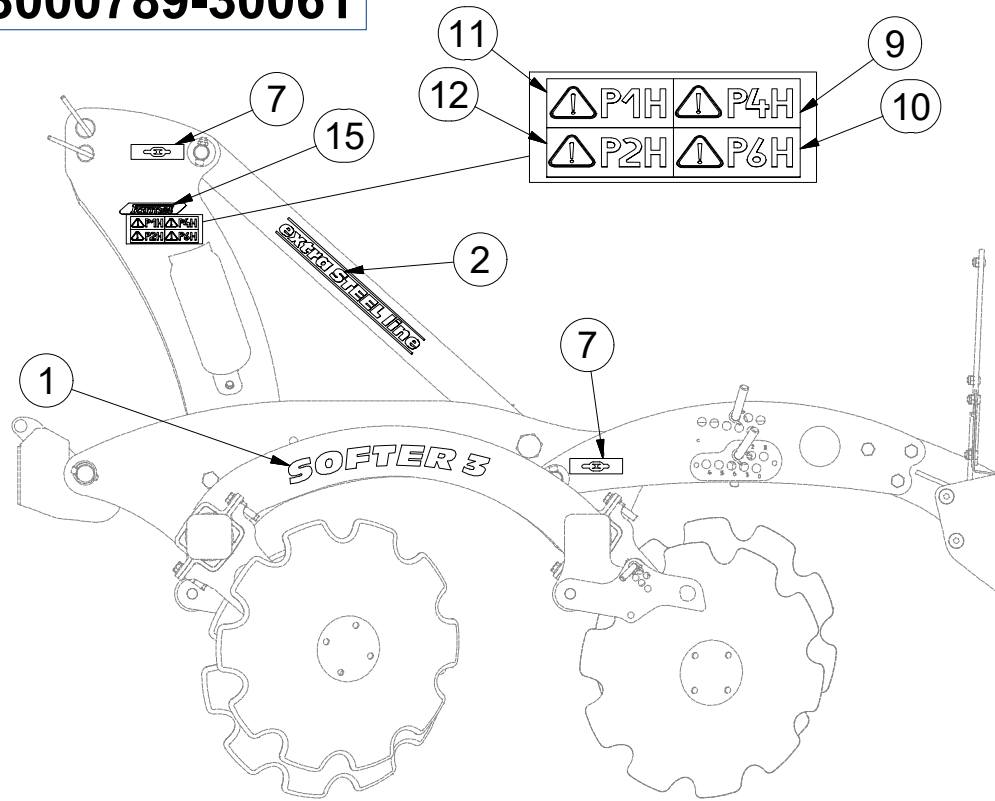

Pos.	Part Number	Pcs.
1	m11786	2
2	m10353	2
5	m03820	1
6	m13116	2
7	m03316	4
9	m04361	1
10	m04360	1
11	m04359	1
12	m04366	1
13	m11297	2
14	m04363	2
15	m13401	2

- Ⓒ UTAHOVACÍ MOMENTY ŠROUBŮ
 Ⓓ ANZUGMOMENTE VON SCHRAUBEN
 Ⓕ COUPLES DE SERRAGE DES VIS

- Ⓖ SCREW TIGHTENING TORQUE
 Ⓔ МОМЕНТЫ ЗАЖАТИЯ БОЛТОВ
 Ⓗ MOMENTY DOKRĘCANIA ŚRUB



P		5.8	8.8	10.9	12.9
D	R	Mu	Mu	Mu	Mu
mm	mm	Nm	Nm	Nm	Nm
M 6	1	6	9	13	15
M 8	1,25	14	22	32	38
M10	1,5	29	44	64	75
M12	1,75	49	76	111	130
M14	2	79	120	176	206
M16	2	123	188	276	323
M18	2,5	169	257	378	443
M20	2,5	239	365	536	628
M22	2,5	329	529	738	864
M24	3	413	629	924	1082
M27	3	613	934	1372	1606
M30	3,5	832	1267	1862	2179
M33	3,5	1130	1723	2530	2961
M36	4	1451	2210	3246	3799
M39	4	1885	2872	4217	4936
M42	4,5	2322	3538	5196	6080
M45	4,5	2909	4433	6511	7619
M48	5	3513	5353	7862	9200
M52	5	4524	6895	10126	11849
M56	5,5	5636	8589	12614	14761

- Mu - Ⓒ UTAHOVACÍ MOMENT Ⓖ TIGHTENING TORQUE
 Ⓓ ANZUGMOMENT Ⓔ МОМЕНТ ЗАЖАТИЯ
 Ⓕ COUPLE DE SERRAGE Ⓗ MOMENT DOKRĘCANIA
 D - Ⓒ JMENOVITÝ PRŮMĚR Ⓖ NOMINAL DIAMETER
 Ⓓ NENNDURCHMESSER Ⓔ НОМИНАЛЬНЫЙ ДИАМЕТР
 Ⓕ DIAMETRE NOMINAL Ⓗ ŚREDNICA NOMINALNA
 R - Ⓒ ROZTEČ ZÁVITU - STOUPÁNÍ Ⓖ SCREW PITCH – LEAD
 Ⓓ GEWINDESTEIGUNG Ⓔ ШАГ РЕЗЬБЫ
 Ⓕ PAS DE FILET - PAS Ⓗ ROZSTAW GWINTU - SKOKI
 P - Ⓒ PEVNOST Ⓖ STRENGTH
 Ⓓ FESTIGKEIT Ⓔ ПРОЧНОСТЬ
 Ⓕ RÉSISTANCE Ⓗ WYTRZYMAŁOŚĆ

- Ⓒ Šroubové spoje utahujte dle vyznačeného utahovacího momentu v dokumentaci. Pokud není utahovací moment v dokumentaci vyznačen, utahujte dle obecné tabulky. Pokud je v dokumentaci definován spoj ze šroubu a matice o různých pevnostech, vždy utahujte na moment komponenty s nižší pevností.
- Ⓓ Ziehen Sie die Schraubverbindungen gemäß dem in der Dokumentation festgeschriebenen Anzugsmoments an. Sofern das Anzugsmoment nicht in der Dokumentation aufgeführt ist, ziehen Sie sie gemäß der allgemeinen Tabelle an. Wenn in der Dokumentation eine Verbindung von Schraube und Mutter mit verschiedenen Festigkeiten definiert ist, wird immer mit dem Moment des Bauteils mit der geringeren Festigkeit angezogen.
- Ⓕ Serrez les raccords à vis selon le couple de serrage indiqué dans les documents. Si le couple de serrage n'est pas indiqué dans les documents, serrez selon le tableau général. Si les documents définissent un assemblage par boulon de diverses résistances, serrez toujours au moment de la composante avec résistance inférieure.
- Ⓖ Tighten the screw joints according to the tightening torque stated in the documentation. If the tightening torque is not stated in the documentation, tighten according to the general table. If there is a joint with a screw and a nut at different strengths in the documentation, always tighten to the torque of the component with lower strength.
- Ⓔ Резьбовые соединения зажимайте с установленным в документации моментом зажатия. Если в документации не указан момент зажатия, то зажимайте по действующей в общем таблице. Если в документации установлено соединение из болта и гайки различной прочности, всегда зажимайте с моментом для компонента с меньшей прочностью.
- Ⓗ Połączenia śrubowe należy dokręcać zgodnie z momentem obrotowym w dokumentacji. Jeśli w dokumentacji nie ma podanego momentu obrotowego, należy dokręcać zgodnie z ogólną tabelą. Jeśli w dokumentacji zdefiniowane jest połączenie ze śrubą i nakrętką o różnych wytrzymałościach, zawsze należy dokręcać zachowując moment dokręcania komponentu z niższą wytrzymałością.

- Ⓒ UTAHOVACÍ MOMENTY ŠROUBŮ
 Ⓓ ANZUGMOMENTE VON SCHRAUBEN
 Ⓕ COUPLES DE SERRAGE DES VIS

- Ⓖ SCREW TIGHTENING TORQUE
 Ⓔ МОМЕНТЫ ЗАЖАТИЯ БОЛТОВ
 Ⓟ MOMENTY DOKRĘCANIA ŚRUB



- Ⓒ **OBECNÝ PŘEDPIS UTAHOVÁNÍ ZAJIŠTĚNÍ ČEPOVÝCH SPOJŮ:**
 Ⓓ **ALLGEMEINE VORSCHRIFT FÜR DAS ANZIEHEN VON BOLZENVERBINDUNGEN:**
 Ⓕ **CONSIGNE GENERALE POUR LE SERRAGE DES ARTICULATIONS CYLINDRIQUES:**
 Ⓖ **GENERAL INSTRUCTION FOR TIGHTENING THE SECURING OF PIN JOINTS:**
 Ⓔ **ОБЩЕЕ ОПИСАНИЕ ЗАЖАТИЯ ПРЕДОХРАНЕНИЯ СОЕДИНЕНИЙ ПАЛЬЦАМИ:**
 Ⓟ **OGÓLNE ZASADY DOKRĘCANIA ZABEZPIECZENIA POŁĄCZEŃ CZOPEM:**

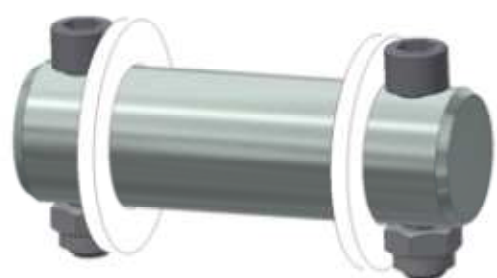

X	M
M8, M10, M12	09-15Nm
M14	15-25Nm

- | | | | |
|------------------------|------------------|-------------------------|-------------------------|
| X - Ⓒ ROZMĚR ŠROUBU | Ⓖ BOLT DIMENSION | M - Ⓒ ORIENTAČNÍ MOMENT | Ⓖ ORIENTATION TORQUE |
| Ⓓ SCHRAUBENGRÖSSE | Ⓔ РАЗМЕР БОЛТА | Ⓓ ANZUGSMOMENT | Ⓔ ОПИЕНТАЦИОННЫЙ МОМЕНТ |
| Ⓕ DIMENSIONS DE LA VIS | Ⓟ ROZMIAR ŚRUBY | Ⓕ COUPLE D'ORIENTATION | Ⓟ ORIENTACYJNY MOMENT |

- Ⓒ Tyto spoje není nutné ověřovat kontrolou momentovým klíčem = stačí vizuálně kontrolovat sešroubování.
 Ⓓ Diese Verbindungen müssen nicht mit einem Drehmomentschlüssel überprüft werden = es genügt, die Verschraubung visuell zu kontrollieren.
 Ⓕ Il n'est pas nécessaire de contrôler le serrage à l'aide d'une clé dynamométrique = un contrôle visuel de l'assemblage suffit.
 Ⓖ These joints do not have to be verified by checking with a torque wrench = visual inspection of bolting is sufficient.
 Ⓔ Эти соединения не нужно контролировать динамометрическим ключом = достаточно визуально проверять прикручивание.
 Ⓟ Nie trzeba sprawdzać tych połączeń kluczem dynamometrycznym = wystarczy wizualnie skontrolować dokręcenie.