

The effective technology

Farmet

ⒸZ KATALOG NÁHRADNÍCH DÍLŮ ⒸB CATALOGUE OF SPARE PARTS ⒸD ERSATZTEILLISTE
ⒸRU КАТАЛОГ ЗАПАСНЫХ ЧАСТЕЙ ⒸF CATALOGUE DES PIÈCES DE RECHANGE ⒸPL KATALOG CZĘŚCI ZAMIENNYCH

КОМПАКТОМАТ K600PS

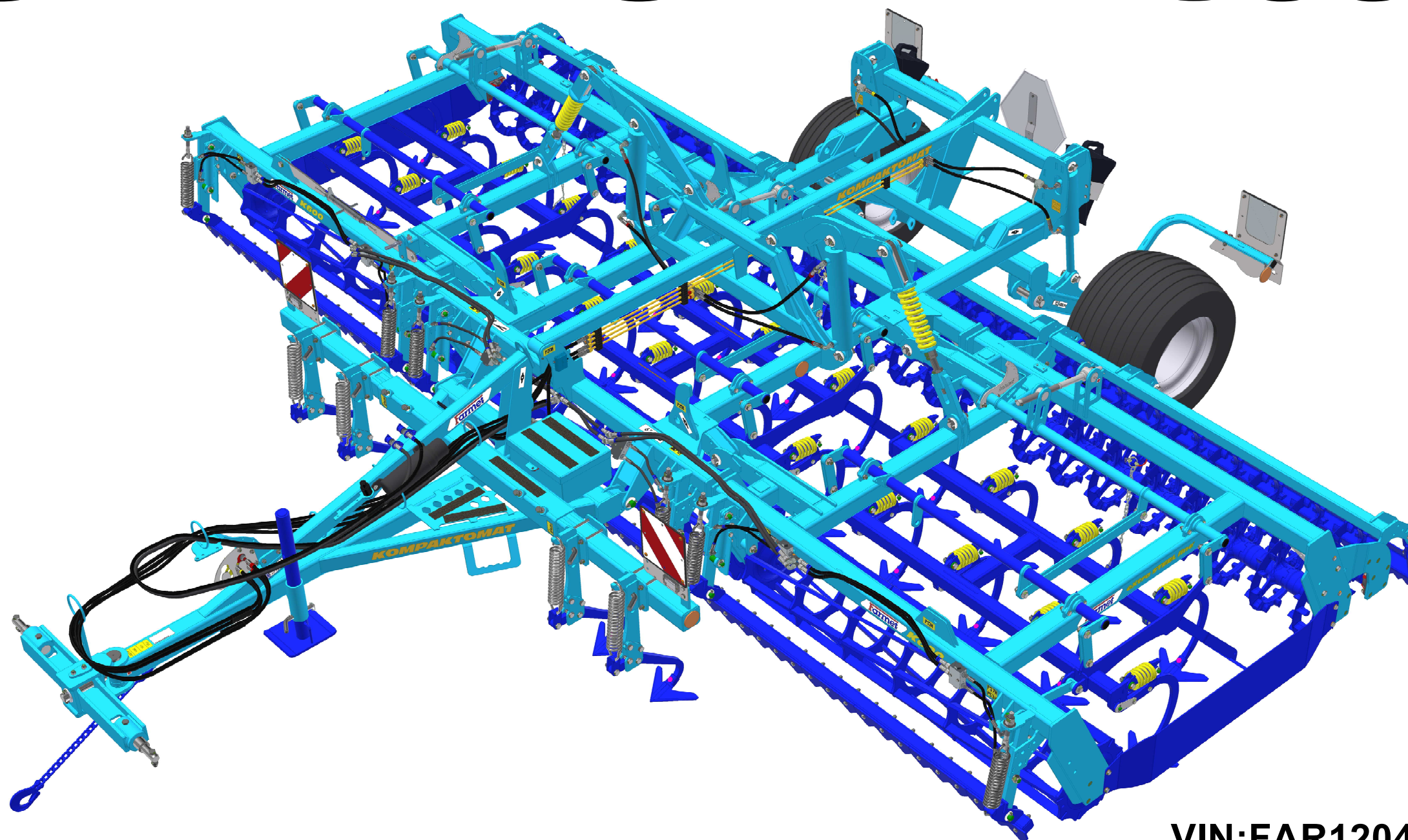

ⒸZ Platnost pro vrcholové | výrobní číslo stroje ⒸB Validity for the top | serial number of the machine
ⒸD Gültigkeit für die Haupt- | Herstellungsnummer der Maschine ⒸRU Действительно для главного | заводского номера машины
ⒸF Validité du numéro de référence | de série de la machine ⒸPL Obowiązuje dla numeru głównego | seryjnego maszyny

VIN: FAR12041CL0000559
9333479 | 2020/0559

Farmet a. s.
Jiřinková 276
552 03 Česká Skalice, CZ

telefon: +420 491 450 111
fax: +420 491 450 136
GSM: +420 774 715 738

IČ: 46504931
DIČ: CZ46504931

web: www.farmet.cz
e-mail: farmet@farmet.cz

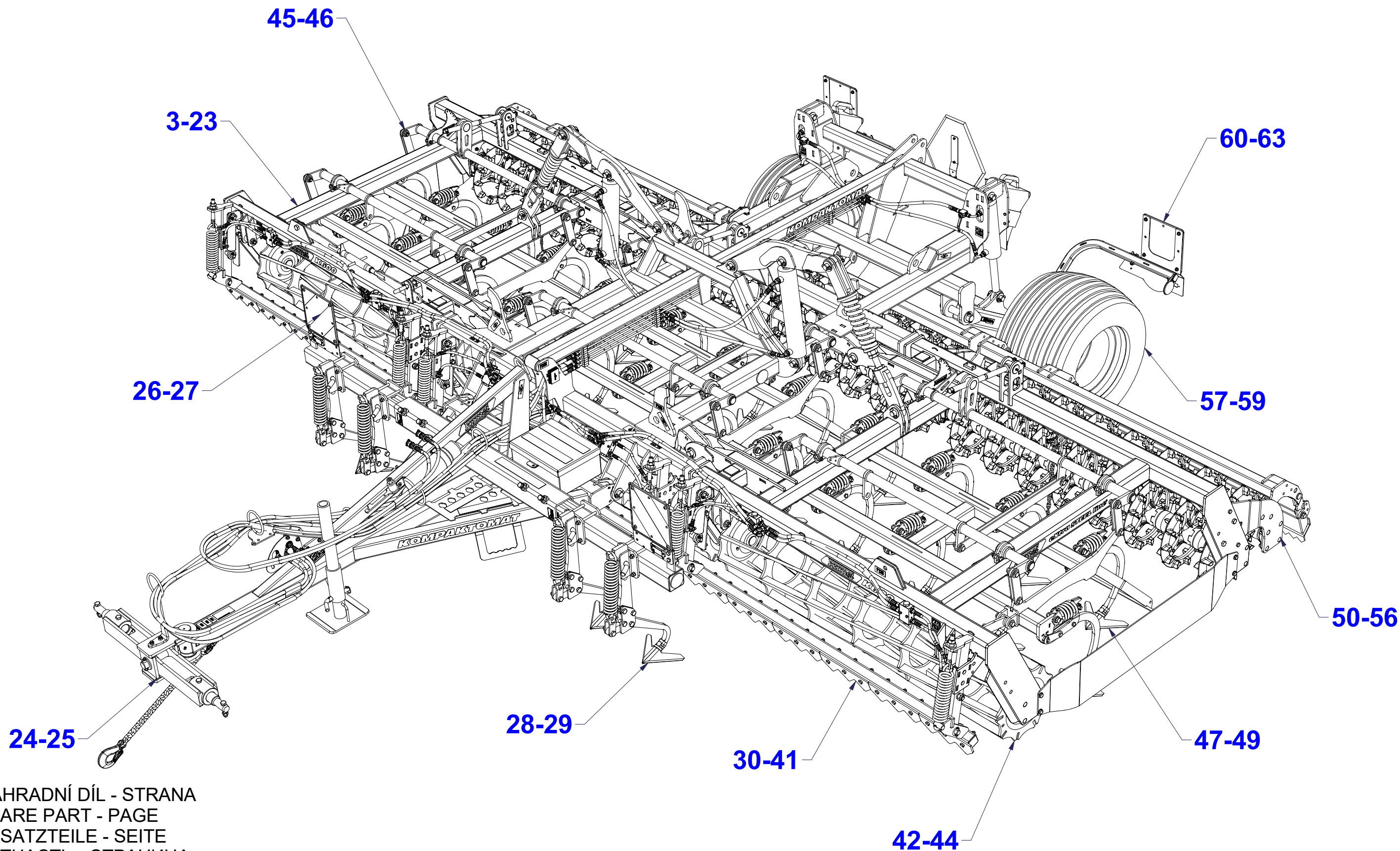

☉ POLOTOVAR STROJE

☉ MASCHINEN-HALBFABRIKAT

☉ MACHINE - SEMI-PRODUIT

☉ SEMIFINISHED MACHINE

☉ ПОЛУФАБРИКАТ МАШИНЫ

☉ PÓLFABRYKAT MASZYNY



3012418

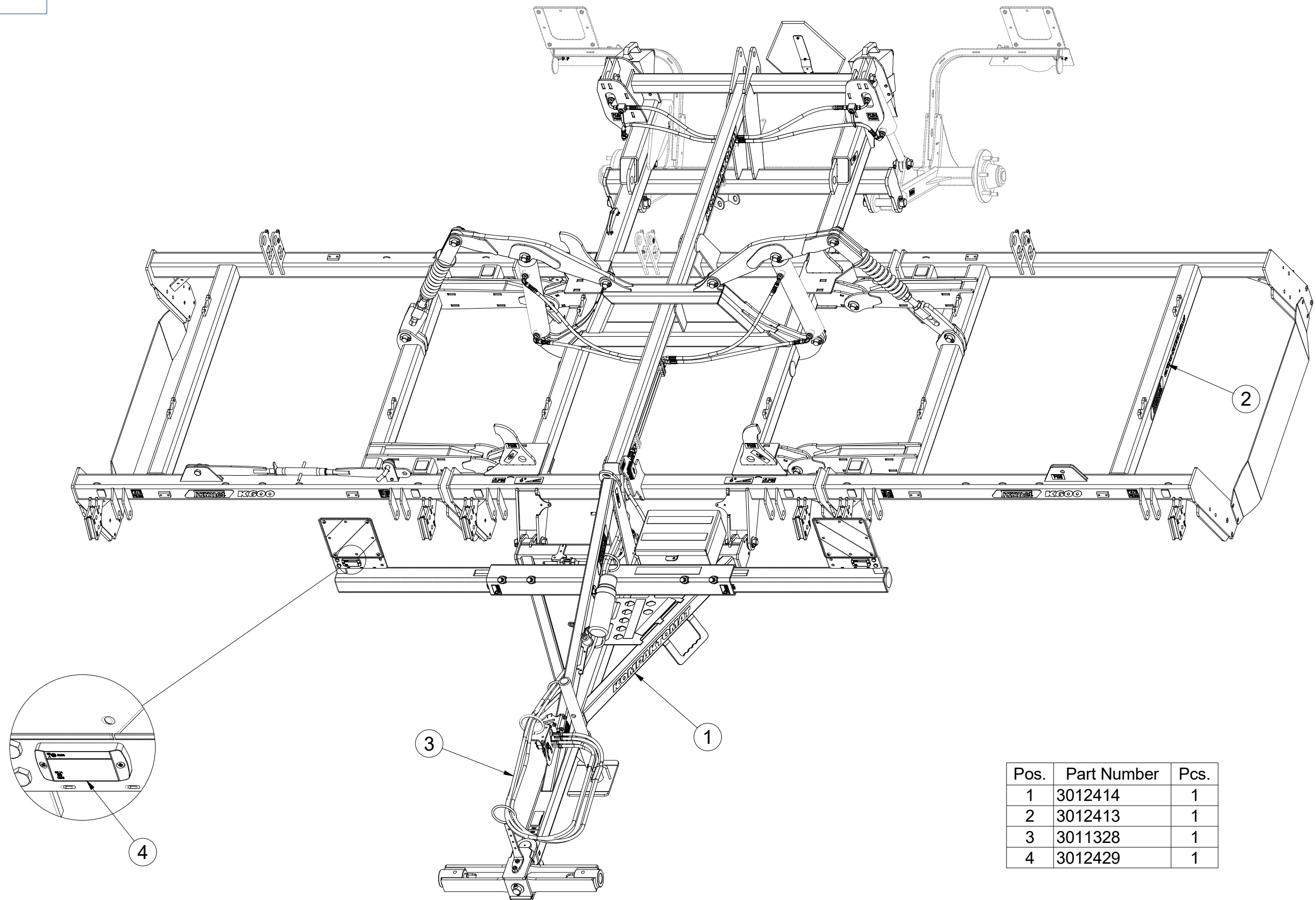

| Pos. | Part Number | Pcs. |
|------|-------------|------|
| 1 | 3012414 | 1 |
| 2 | 3012413 | 1 |
| 3 | 3011328 | 1 |
| 4 | 3012429 | 1 |

☉ POLOTOVAR STROJE

☉ MASCHINEN-HALBFABRIKAT

☉ MACHINE - SEMI-PRODUIT

☉ SEMIFINISHED MACHINE

☉ ПОЛУФАБРИКАТ МАШИНЫ

☉ PÓLFABRYKAT MASZYNY



3012418

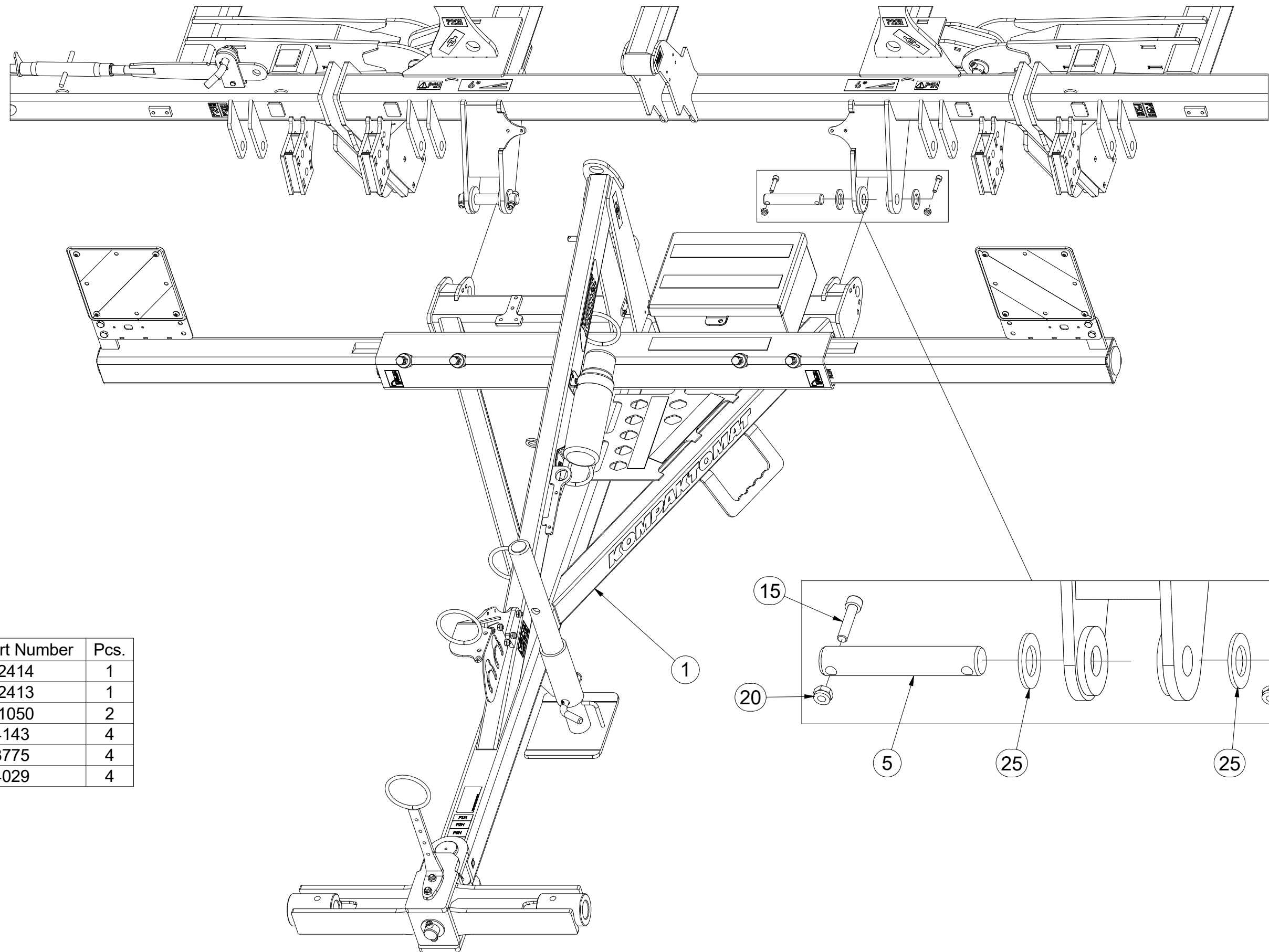

| Pos. | Part Number | Pcs. |
|------|-------------|------|
| 1 | 3012414 | 1 |
| 2 | 3012413 | 1 |
| 5 | 4011050 | 2 |
| 15 | m14143 | 4 |
| 20 | m03775 | 4 |
| 25 | m14029 | 4 |

☉ POLOTOVAR STROJE

☉ MASCHINEN-HALBFABRIKAT

☉ MACHINE - SEMI-PRODUIT

☉ SEMIFINISHED MACHINE

☉ ПОЛУФАБРИКАТ МАШИНЫ

☉ PÓLFABRYKAT MASZYNY



3012413

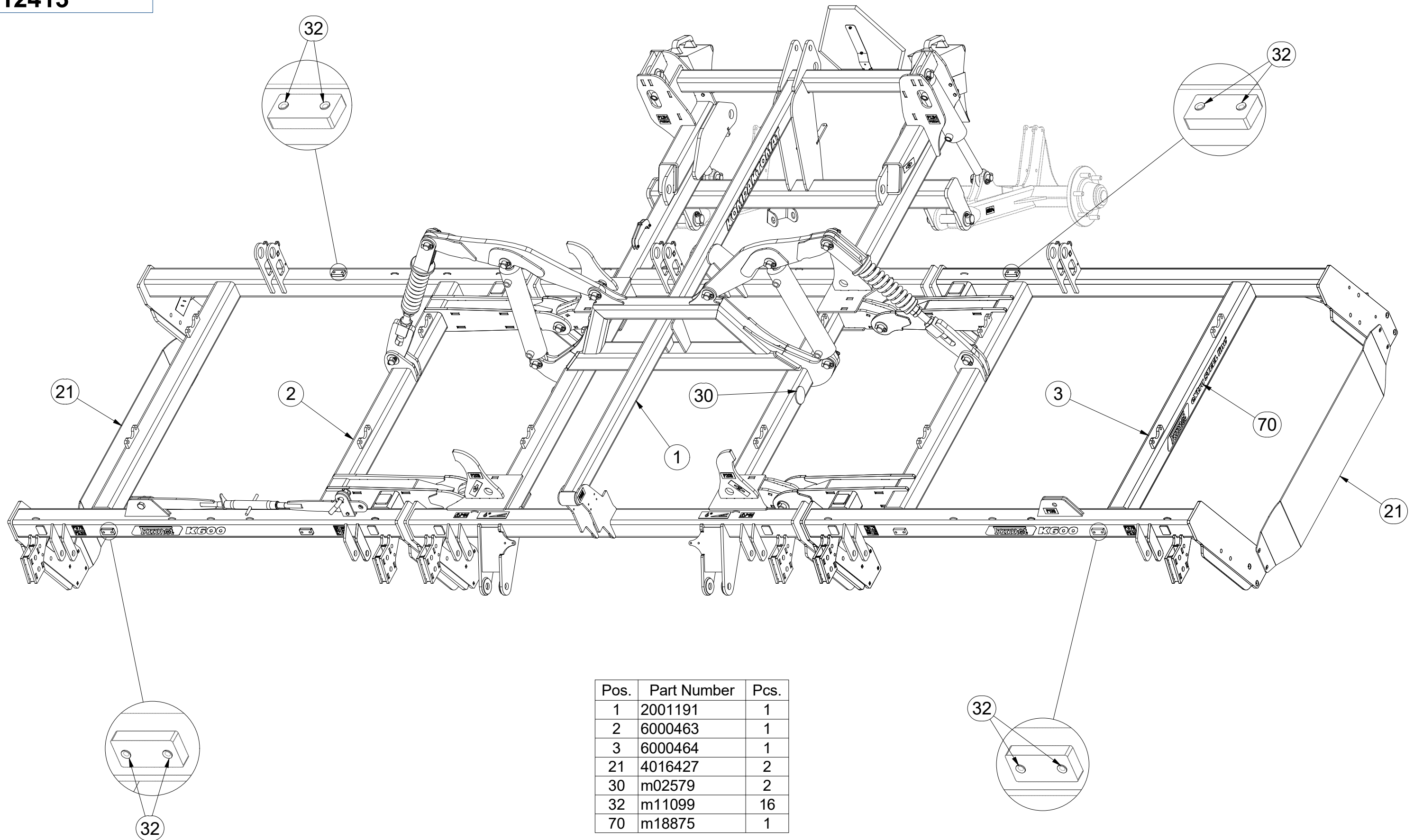

| Pos. | Part Number | Pcs. |
|------|-------------|------|
| 1 | 2001191 | 1 |
| 2 | 6000463 | 1 |
| 3 | 6000464 | 1 |
| 21 | 4016427 | 2 |
| 30 | m02579 | 2 |
| 32 | m11099 | 16 |
| 70 | m18875 | 1 |

☉ POLOTOVAR STROJE

☉ MASCHINEN-HALBFABRIKAT

☉ MACHINE - SEMI-PRODUIT

☉ SEMIFINISHED MACHINE

☉ ПОЛУФАБРИКАТ МАШИНЫ

☉ PÓLFABRYKAT MASZYNY



3012413

| Pos. | Part Number | Pcs. | Pos. | Part Number | Pcs. |
|------|-------------|------|------|-------------|------|
| 2 | 6000463 | 1 | 42 | m01096 | 1 |
| 5 | 4005363 | 2 | 43 | m14143 | 36 |
| 6 | 4021664 | 2 | 45 | m04241 | 1 |
| 9 | 4003966 | 1 | 51 | m04503 | 9 |
| 11 | 4014569 | 2 | 52 | m03775 | 36 |
| 12 | 4012011 | 1 | 54 | m05648 | 1 |
| 13 | m10454 | 1 | 55 | m04043 | 2 |
| 17 | 4007584 | 2 | 61 | m14029 | 36 |
| 19 | 4007641 | 4 | | | |

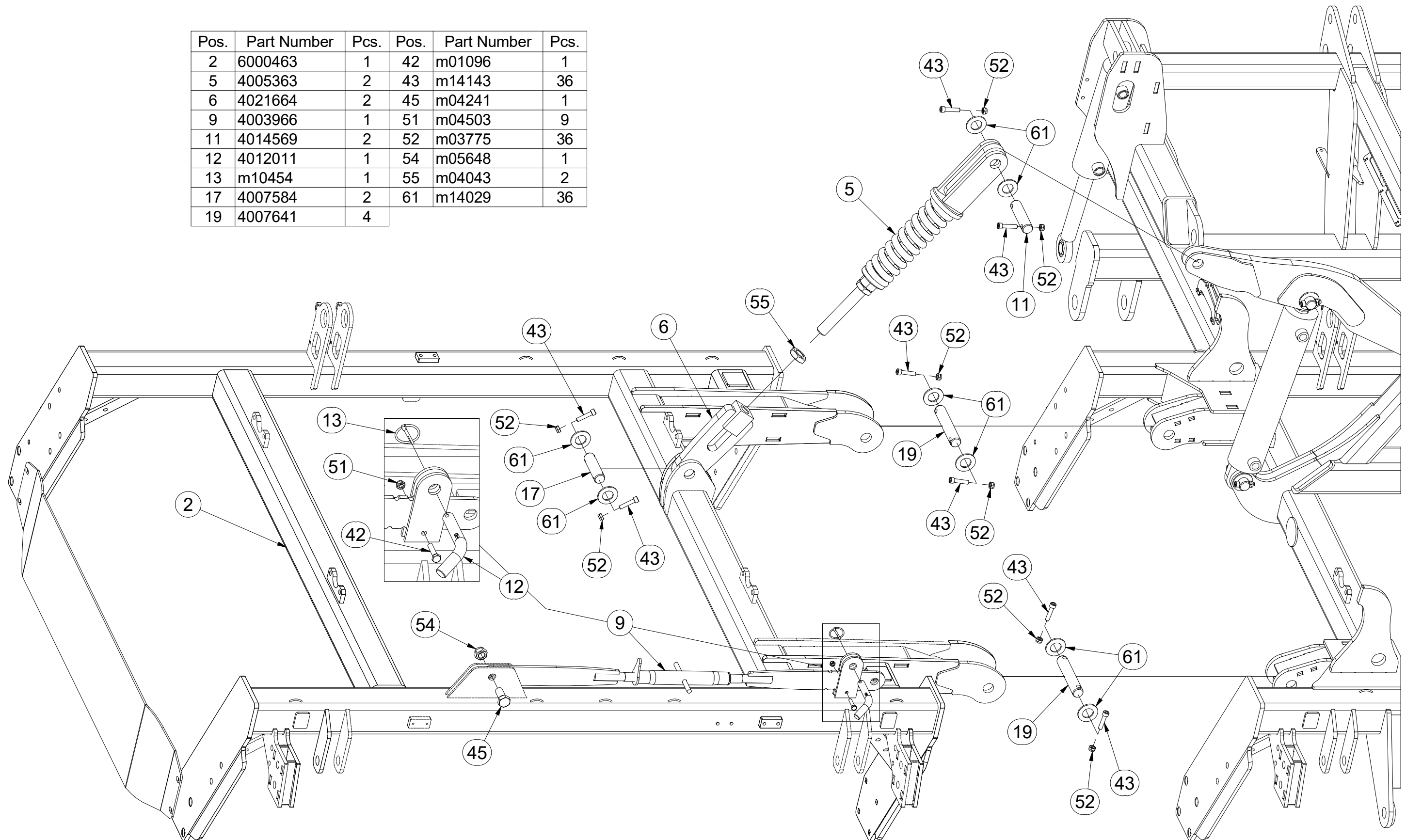

☉ POLOTOVAR STROJE

☉ MASCHINEN-HALBFABRIKAT

☉ MACHINE - SEMI-PRODUIT

☉ SEMIFINISHED MACHINE

☉ ПОЛУФАБРИКАТ МАШИНЫ

☉ PÓŁFABRYKAT MASZYNY



3012413

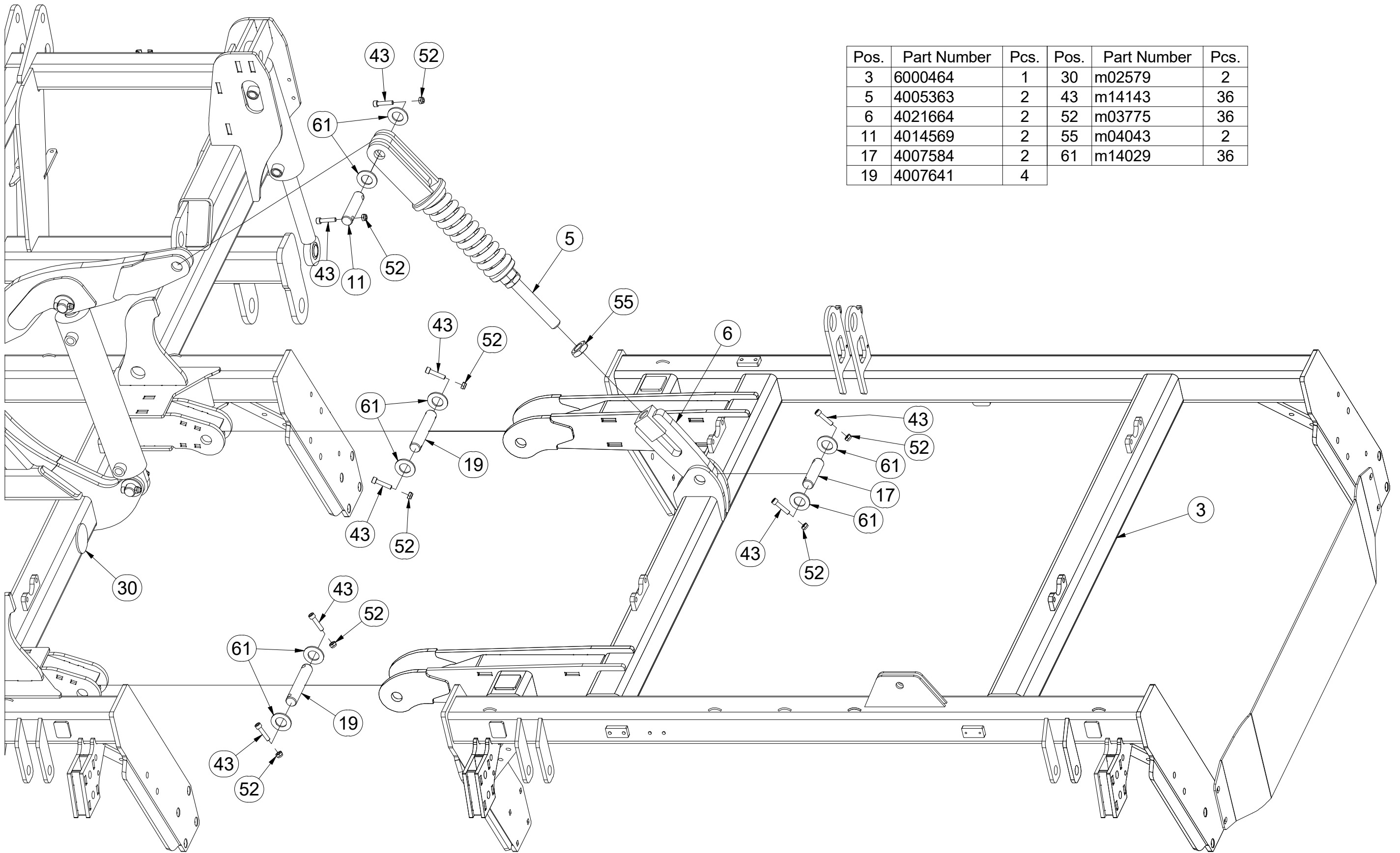

| Pos. | Part Number | Pcs. | Pos. | Part Number | Pcs. |
|------|-------------|------|------|-------------|------|
| 3 | 6000464 | 1 | 30 | m02579 | 2 |
| 5 | 4005363 | 2 | 43 | m14143 | 36 |
| 6 | 4021664 | 2 | 52 | m03775 | 36 |
| 11 | 4014569 | 2 | 55 | m04043 | 2 |
| 17 | 4007584 | 2 | 61 | m14029 | 36 |
| 19 | 4007641 | 4 | | | |

☉ POLOTOVAR STROJE

☉ MASCHINEN-HALBFABRIKAT

☉ MACHINE - SEMI-PRODUIT

☉ SEMIFINISHED MACHINE

☉ ПОЛУФАБРИКАТ МАШИНЫ

☉ PÓLFABRYKAT MASZYNY



3012413

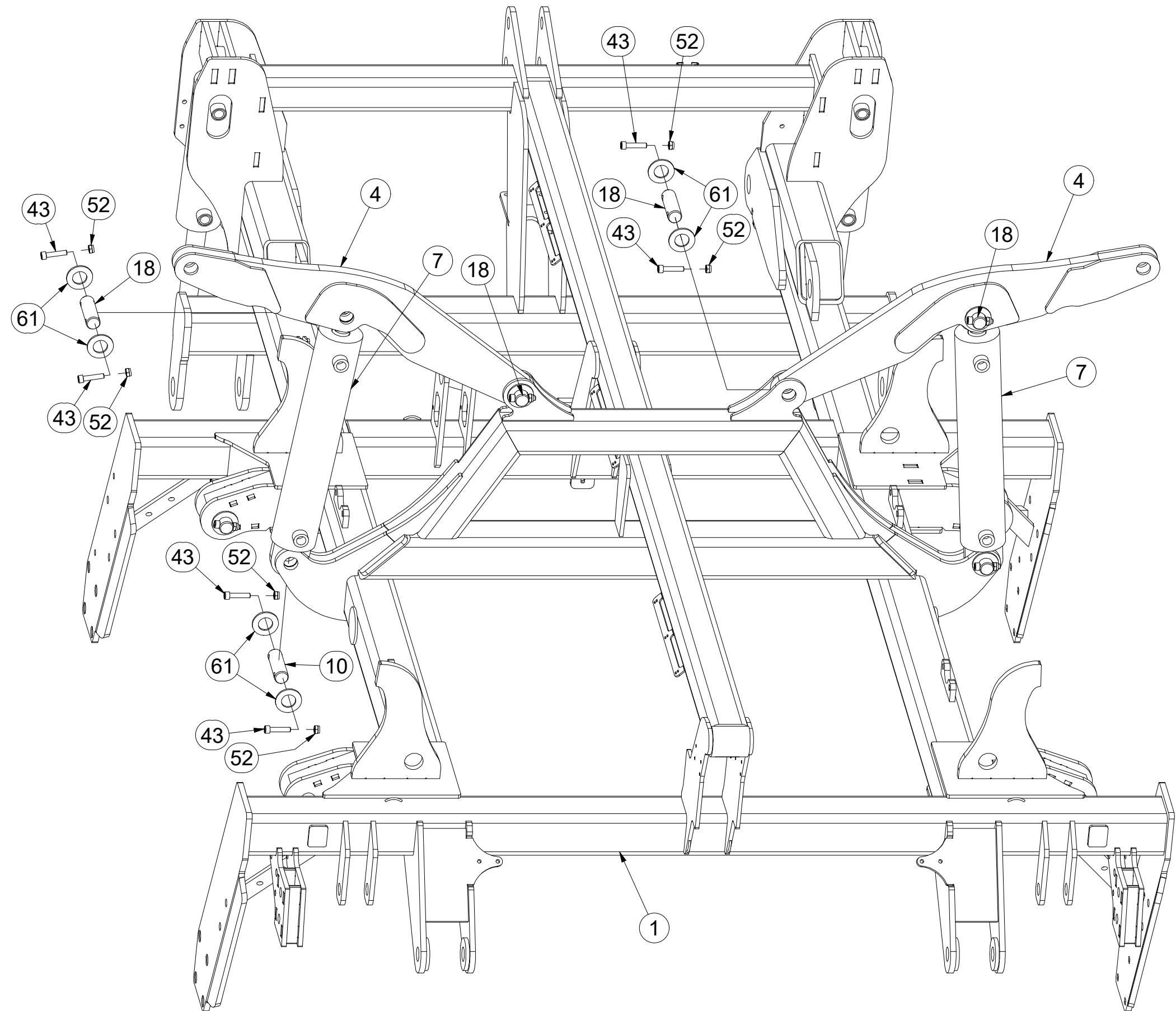

| Pos. | Part Number | Pcs. |
|------|-------------|------|
| 1 | 2001191 | 1 |
| 4 | 3002837 | 2 |
| 7 | VZ00004544 | 2 |
| 10 | 4008234 | 6 |
| 18 | 4007640 | 4 |
| 43 | m14143 | 36 |
| 52 | m03775 | 36 |
| 61 | m14029 | 36 |

☉ POLOTOVAR STROJE

☐ MASCHINEN-HALBFABRIKAT

☉ MACHINE - SEMI-PRODUIT

☉ SEMIFINISHED MACHINE

☉ ПОЛУФАБРИКАТ МАШИНЫ

☉ PÓLFABRYKAT MASZYNY



3012413

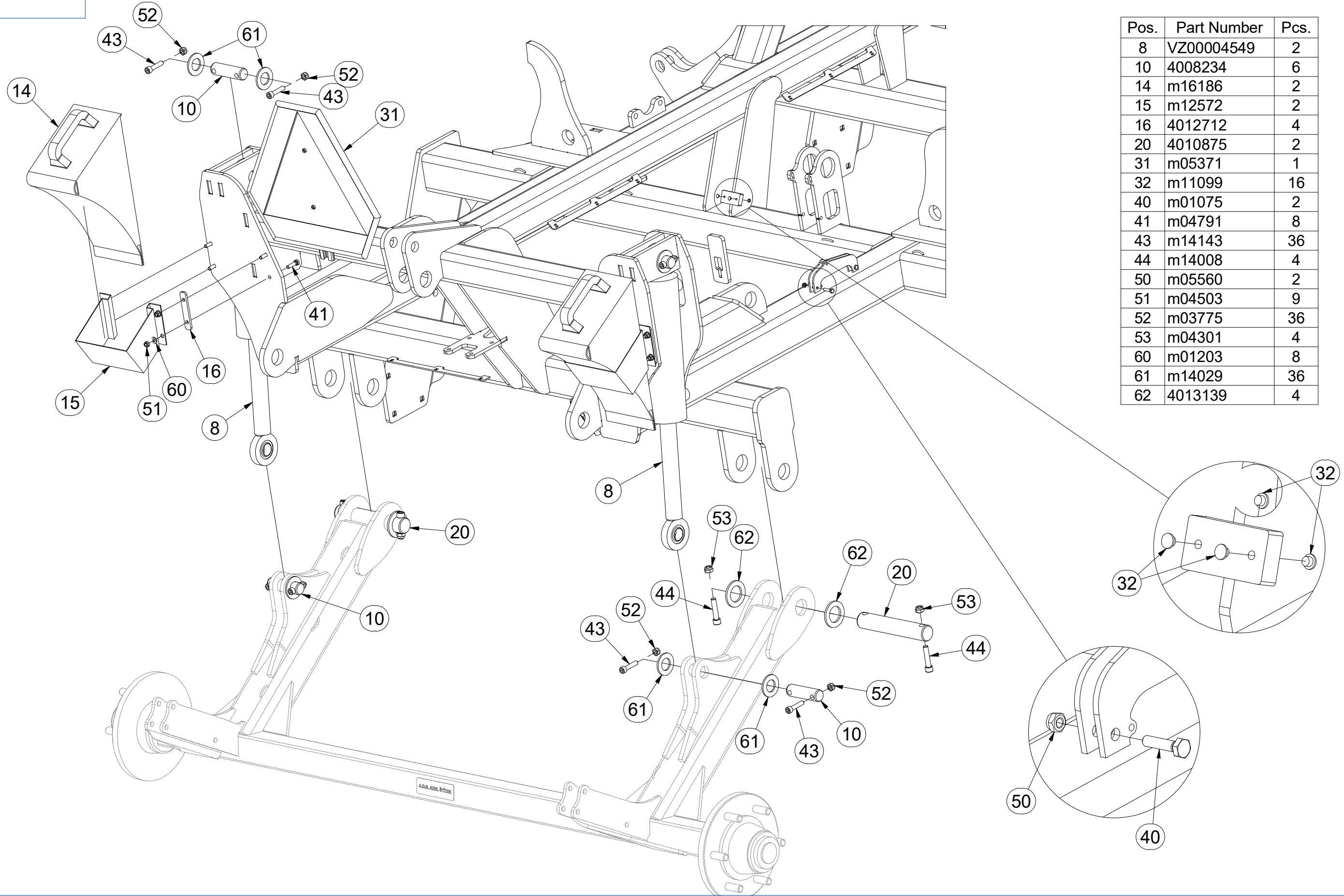

| Pos. | Part Number | Pcs. |
|------|-------------|------|
| 8 | VZ00004549 | 2 |
| 10 | 4008234 | 6 |
| 14 | m16186 | 2 |
| 15 | m12572 | 2 |
| 16 | 4012712 | 4 |
| 20 | 4010875 | 2 |
| 31 | m05371 | 1 |
| 32 | m11099 | 16 |
| 40 | m01075 | 2 |
| 41 | m04791 | 8 |
| 43 | m14143 | 36 |
| 44 | m14008 | 4 |
| 50 | m05560 | 2 |
| 51 | m04503 | 9 |
| 52 | m03775 | 36 |
| 53 | m04301 | 4 |
| 60 | m01203 | 8 |
| 61 | m14029 | 36 |
| 62 | 4013139 | 4 |

☉ SAMOLEPKY STROJE

☉ AUFKLEBER MASCHINEN

☉ VOITURE MACHINES

☉ STICKERS MACHINES

☉ СТИКЕРЫ МАШИНЫ

☉ NAKLEJKI MASZYNY



m18875

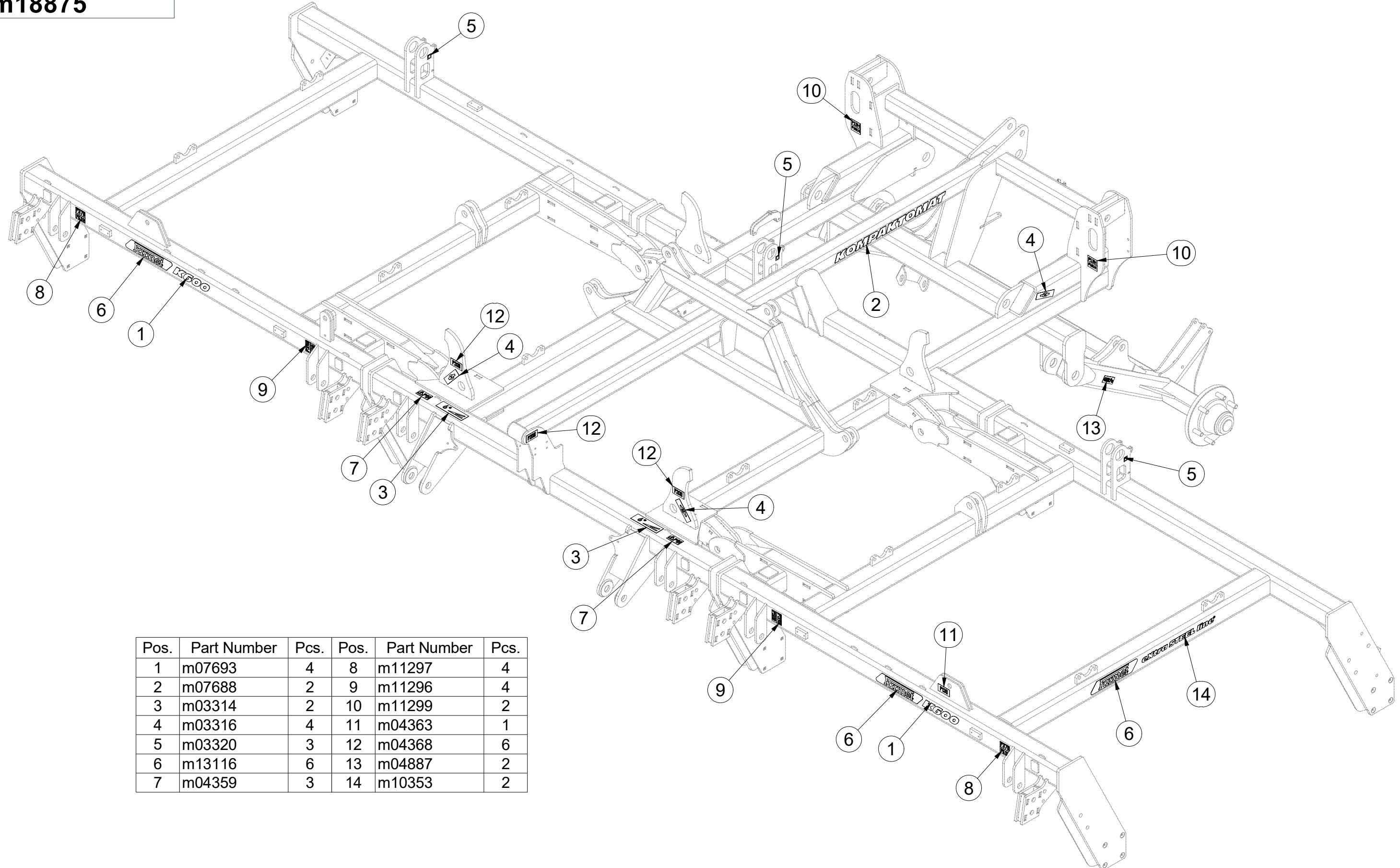

| Pos. | Part Number | Pcs. | Pos. | Part Number | Pcs. |
|------|-------------|------|------|-------------|------|
| 1 | m07693 | 4 | 8 | m11297 | 4 |
| 2 | m07688 | 2 | 9 | m11296 | 4 |
| 3 | m03314 | 2 | 10 | m11299 | 2 |
| 4 | m03316 | 4 | 11 | m04363 | 1 |
| 5 | m03320 | 3 | 12 | m04368 | 6 |
| 6 | m13116 | 6 | 13 | m04887 | 2 |
| 7 | m04359 | 3 | 14 | m10353 | 2 |

ⒸZ SAMOLEPKY STROJE

Ⓓ AUFKLEBER MASCHINEN

Ⓕ VOITURE MACHINES

ⒸB STICKERS MACHINES

ⒸU СТИКЕРЫ МАШИНЫ

ⒸL NAKLEJKI MASZYNY



m18875

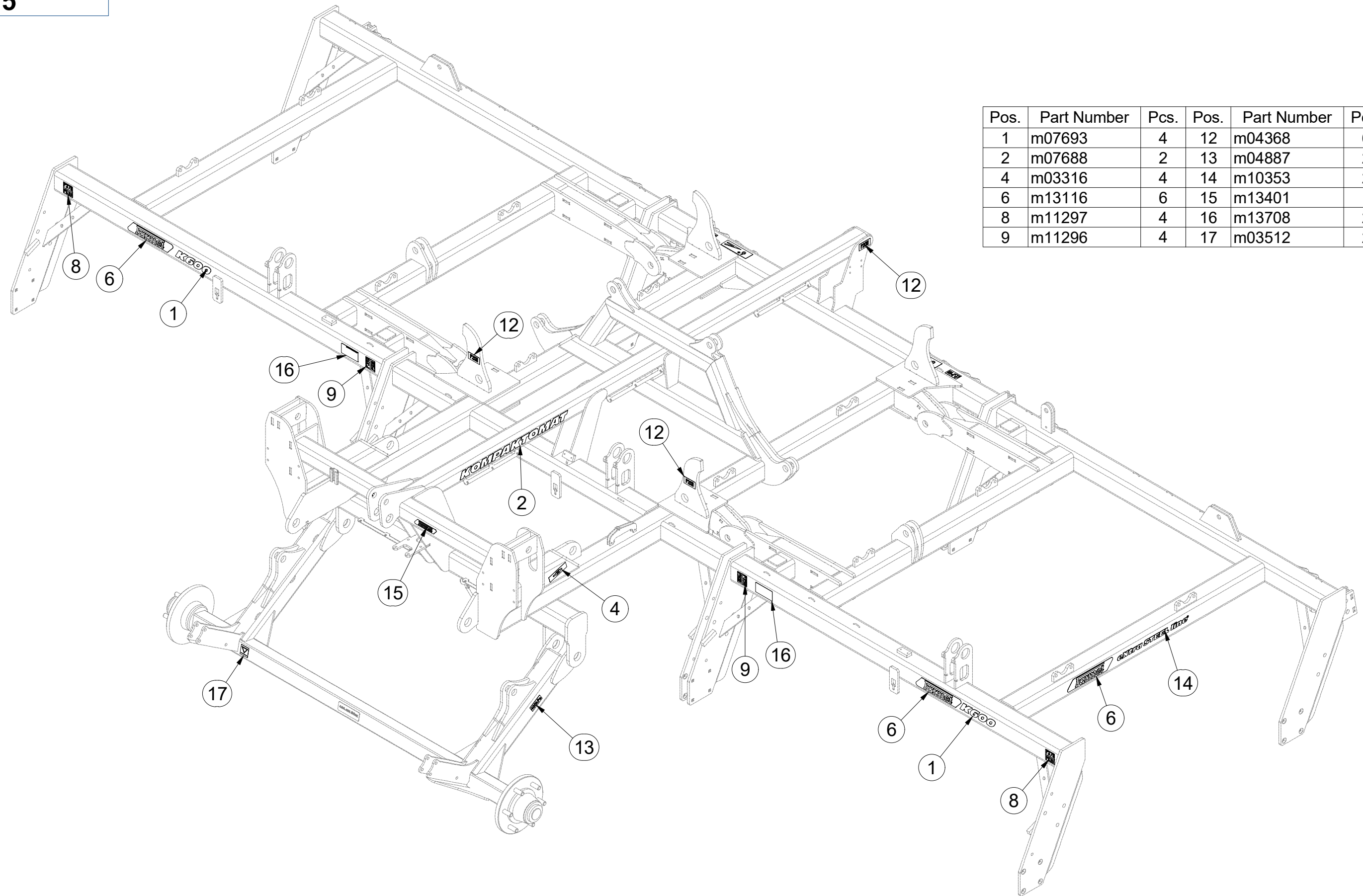

| Pos. | Part Number | Pcs. | Pos. | Part Number | Pcs. |
|------|-------------|------|------|-------------|------|
| 1 | m07693 | 4 | 12 | m04368 | 6 |
| 2 | m07688 | 2 | 13 | m04887 | 2 |
| 4 | m03316 | 4 | 14 | m10353 | 2 |
| 6 | m13116 | 6 | 15 | m13401 | 1 |
| 8 | m11297 | 4 | 16 | m13708 | 2 |
| 9 | m11296 | 4 | 17 | m03512 | 2 |

CZ NASAZOVACÍ KLIKA
 D EINSTELLKURBEL
 F MANIVELLE AMOVIBILE

GB PRESS-ON HANDLE
 RU НАСАЖИВАЕМАЯ РУКОЯТКА
 PL KLAMKA MOCOWANA



4003087

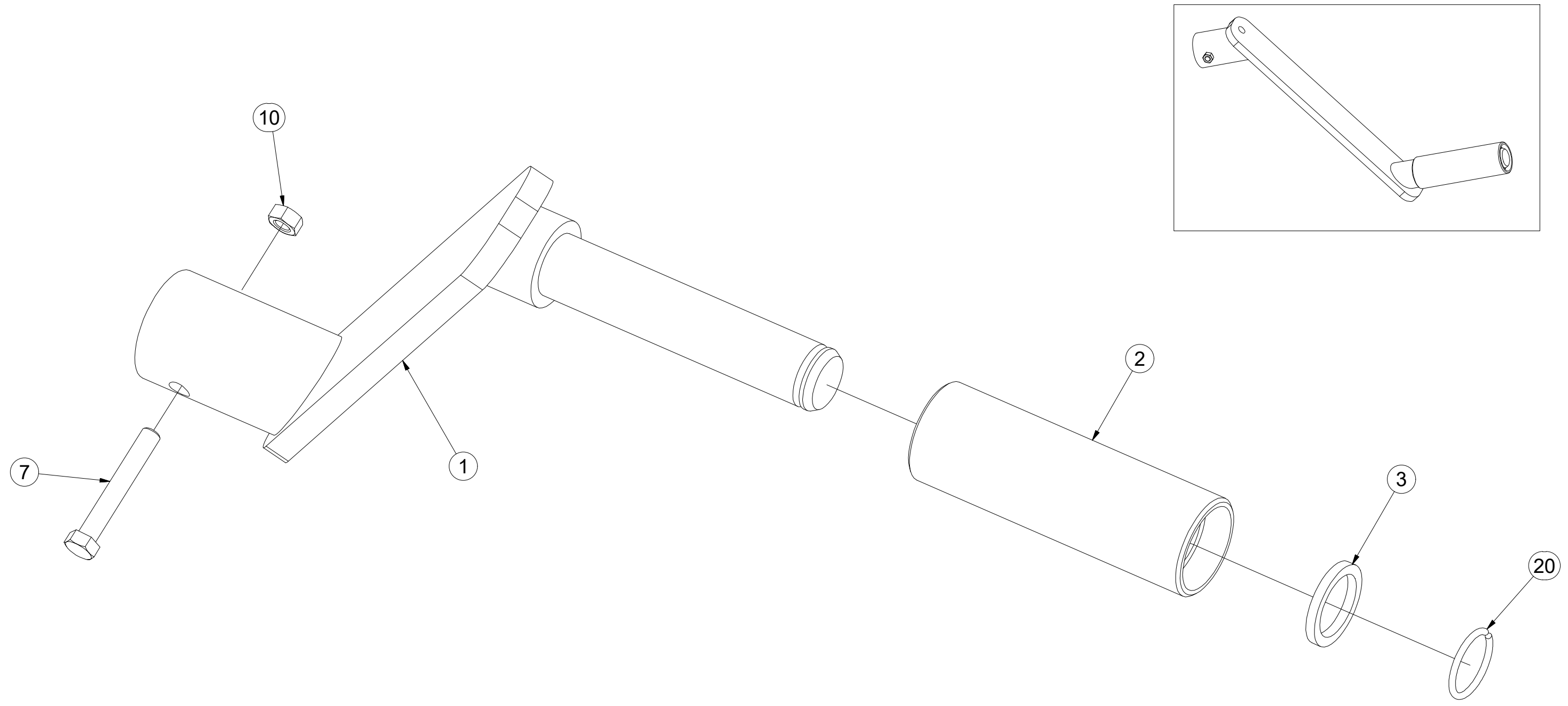

| Pos. | Part Number | Pcs. |
|------|-------------|------|
| 1 | 4003092 | 1 |
| 2 | 4001533 | 1 |
| 3 | 4004828 | 1 |
| 7 | m04641 | 1 |
| 10 | m01295 | 1 |
| 20 | m06561 | 1 |

☉ SPOJOVACÍ TÁHLO

☐ VERBINDUNGSSTANGE

☐ TIGE DE RACCORDEMENT

4003966

☉ CONNECTING ROD

☉ СОЕДИНИТЕЛЬНАЯ ТЯГА

☉ KORBOWÓD

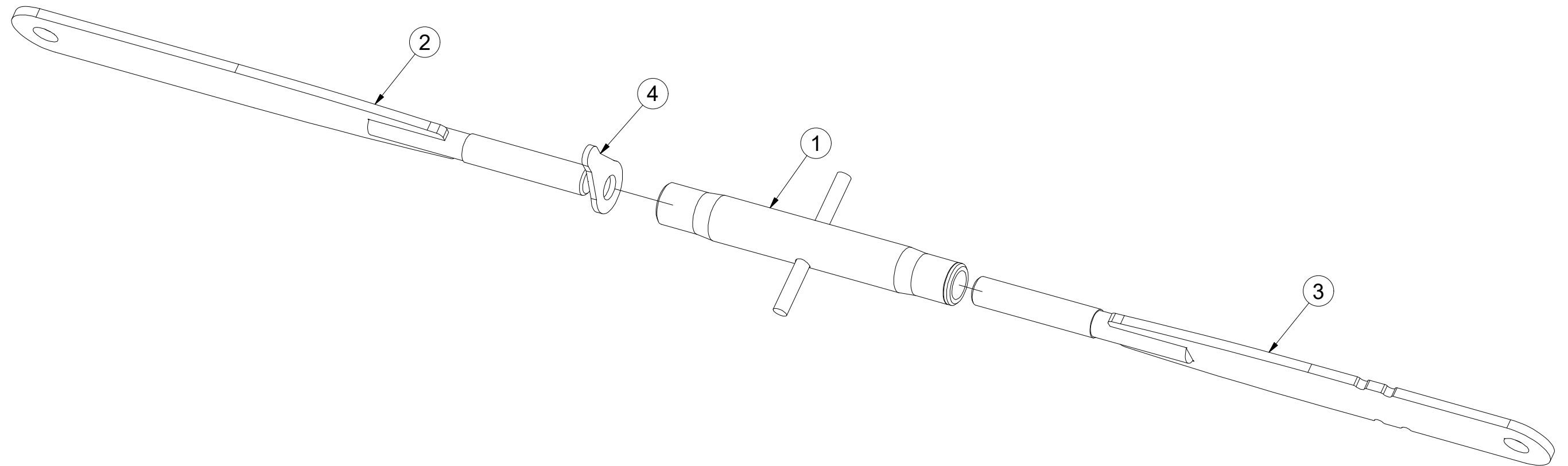
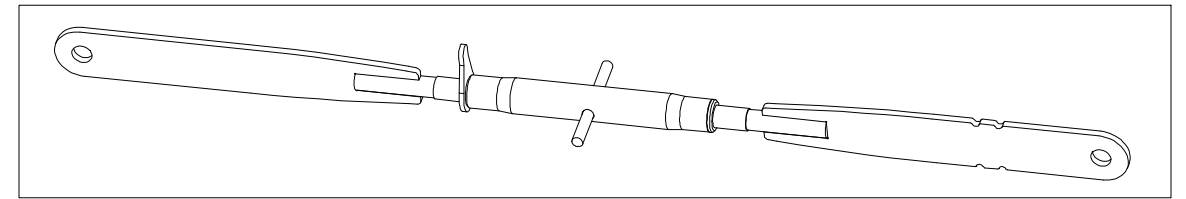

| Poz | Číslo součásti | Ks |
|-----|----------------|----|
| 1 | m08880 | 1 |
| 2 | 4023421 | 1 |
| 3 | 4023423 | 1 |
| 4 | m08881 | 1 |

Ⓒ TÁHLO SKLÁPĚNÍ

Ⓓ ZUGSTANGE ZUR KIPPUNG

Ⓕ TIGES DE L'ESSIEU

4005363

Ⓖ TILTING PULL ROD

Ⓡ ТЯГИ ТРАНСПОРТНОЙ ОСИ

Ⓢ SPRZĘGI OSI

Farmet

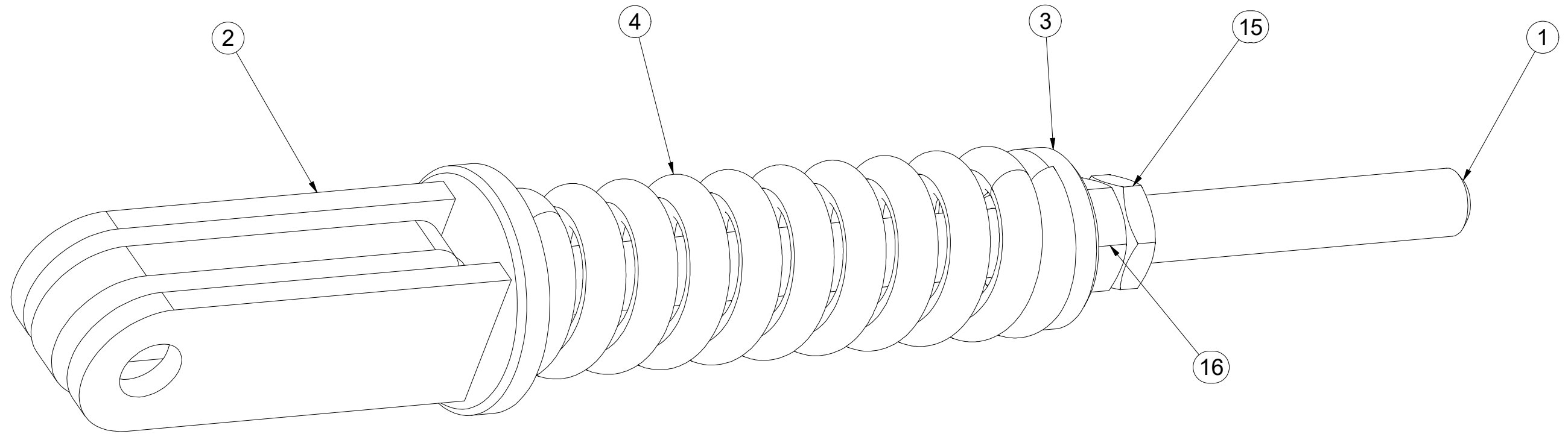

| Pos. | Part Number | Pcs. |
|------|-------------|------|
| 1 | 4005358 | 1 |
| 2 | 4005361 | 1 |
| 3 | 4000023 | 1 |
| 4 | m06482 | 1 |
| 15 | m04043 | 1 |
| 16 | m01309 | 1 |

ⒸZ HYDRAULIKA STROJE
Ⓓ HYDRAULIK DER MASCHINE
Ⓕ HYDRAULIQUE DE LA MACHINE

ⒸB MACHINE HYDRAULICS
ⒸR ГИДРАВЛИКА МАШИНЫ
ⒸL HYDRAULIKA MASZYN



3011328

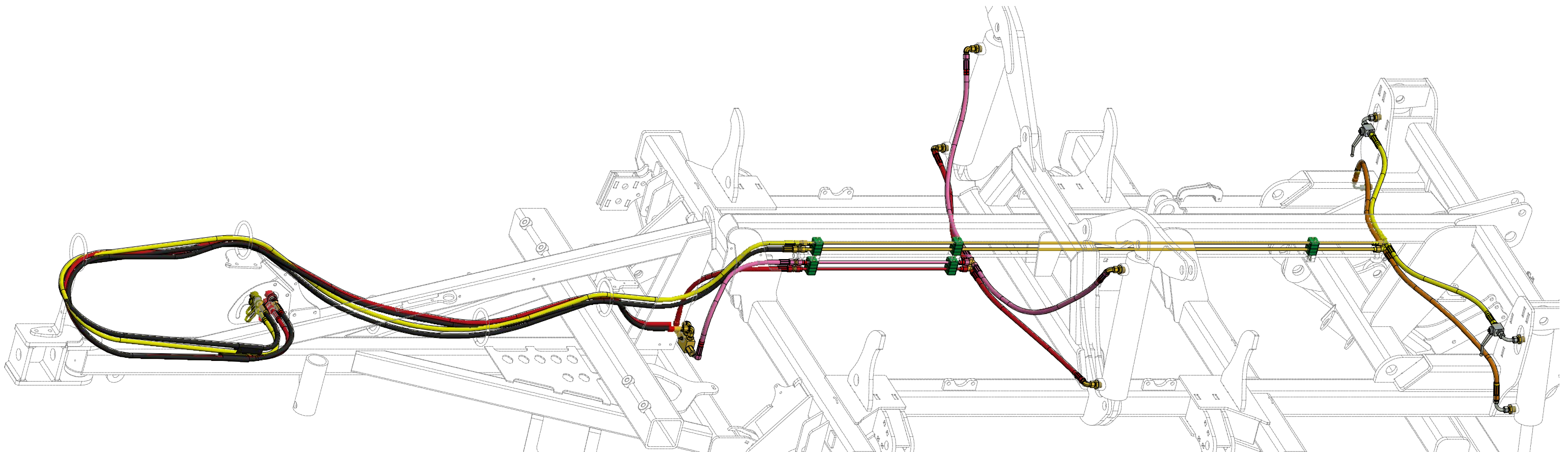

| Pos. | Part Number | Pcs. |
|------|-------------|------|
| 1 | m17907 | 1 |

ⒸZ HYDRAULICKÝ ROZVOD SKLÁPĚNÍ

Ⓓ HYDRAULISCHE VERTEILUNG KLAPPMECHANISMUS

Ⓕ CONDUIT HYDRAULIQUE DU BASCULEMENT

ⒸB HYDRAULIC FOLDING DISTRIBUTION

ⒸU ГИДРАВЛИЧЕСКОЕ РАСПРЕДЕЛЕНИЕ СКЛАДЫВАНИЯ

ⒸL HYDRAULICZNY PRZEWÓD SKŁADANIA



3011328

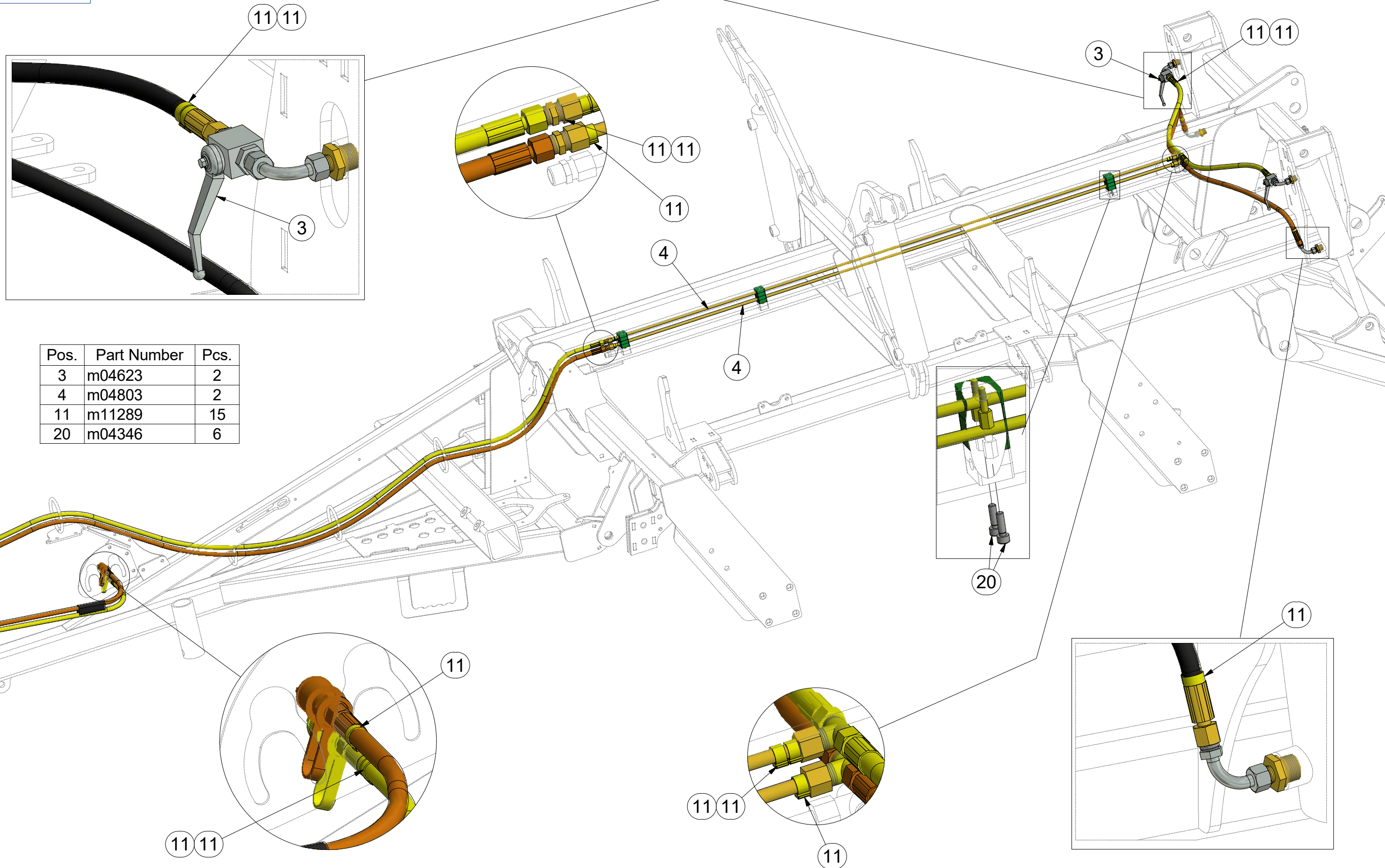

| Pos. | Part Number | Pcs. |
|------|-------------|------|
| 3 | m04623 | 2 |
| 4 | m04803 | 2 |
| 11 | m11289 | 15 |
| 20 | m04346 | 6 |

ⒸZ HYDRAULICKÝ ROZVOD SKLÁPĚNÍ

Ⓓ HYDRAULISCHE VERTEILUNG KLAPPMECHANISMUS

Ⓕ CONDUIT HYDRAULIQUE DU BASCULEMENT

ⒼB HYDRAULIC FOLDING DISTRIBUTION

Ⓔ RU ГИДРАВЛИЧЕСКОЕ РАСПРЕДЕЛЕНИЕ СКЛАДЫВАНИЯ

Ⓗ PL HYDRAULICZNY PRZEWÓD SKŁADANIA



m17907

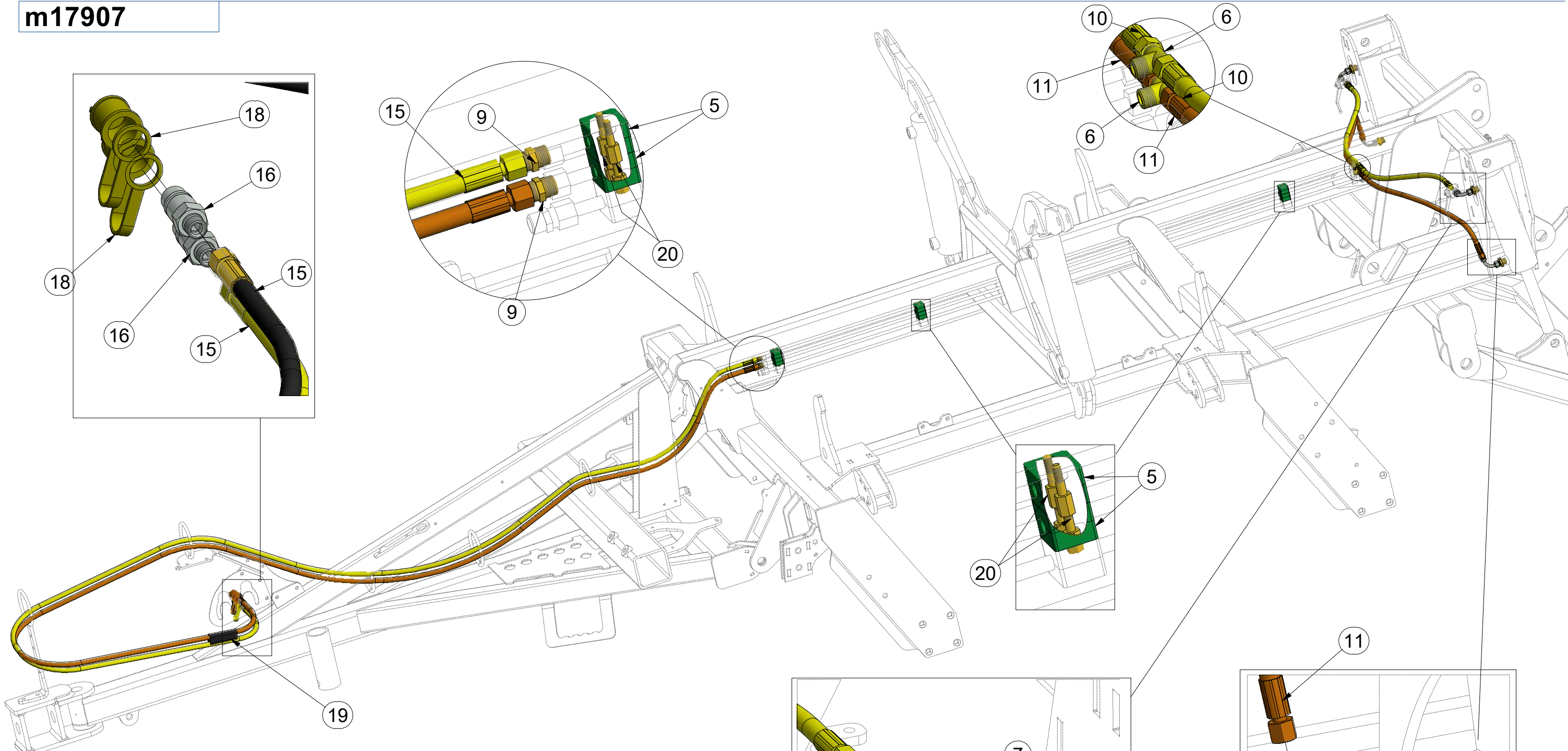

| Pos. | Part Number | Pcs. | Pos. | Part Number | Pcs. |
|------|-------------|------|------|-------------|------|
| 2 | m04024 | 2 | 11 | m04033 | 2 |
| 5 | m04009 | 10 | 15 | m09431 | 2 |
| 6 | m03889 | 4 | 16 | m03849 | 4 |
| 7 | m09934 | 8 | 18 | m04023 | 2 |
| 8 | m04621 | 2 | 19 | m11183 | 2 |
| 9 | m03213 | 4 | 20 | m04021 | 14 |
| 10 | m03713 | 4 | | | |

HYDRAULIC COMPONENTS:
M16 x 1,5 - 60Nm
M22 x 1,5 - 140Nm
G 3/8 - 95 Nm

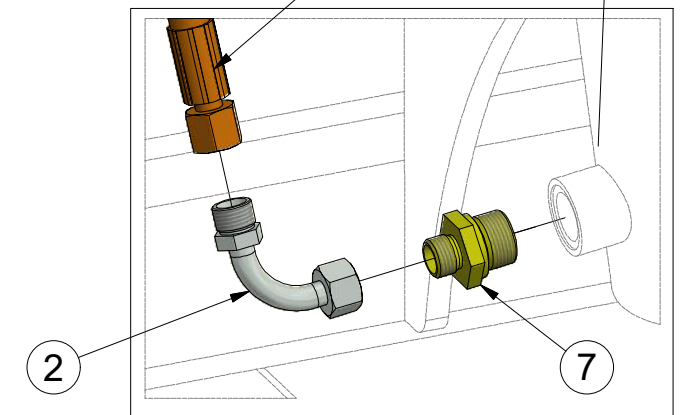
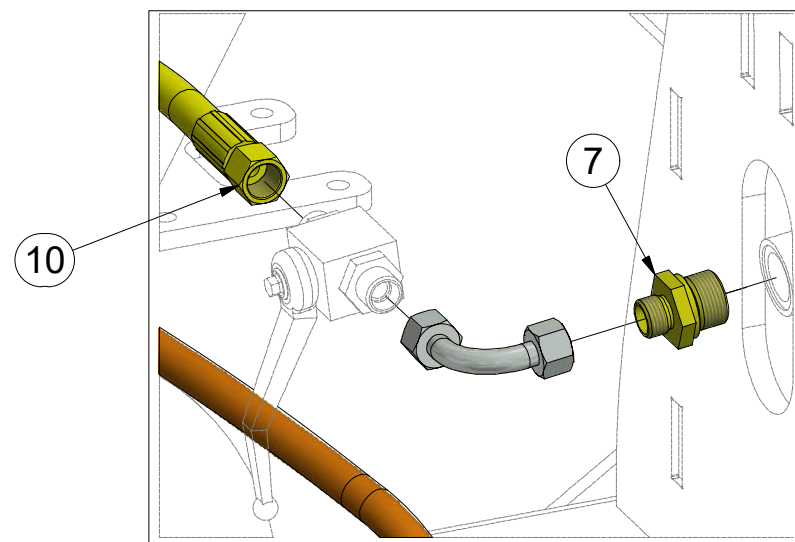

ⒸZ HYDRAULICKÝ ROZVOD NÁPRAVY

Ⓓ HYDRAULISCHE VERTEILUNG ACHSE

Ⓕ CONDUIT HYDRAULIQUE DE L'ESSIEU

ⒸB HYDRAULIC AXLE DISTRIBUTION

ⒸU ГИДРАВЛИЧЕСКОЕ РАСПРЕДЕЛЕНИЕ ОСИ

ⒸL HYDRAULICZNY PRZEWÓD OSI



3011328

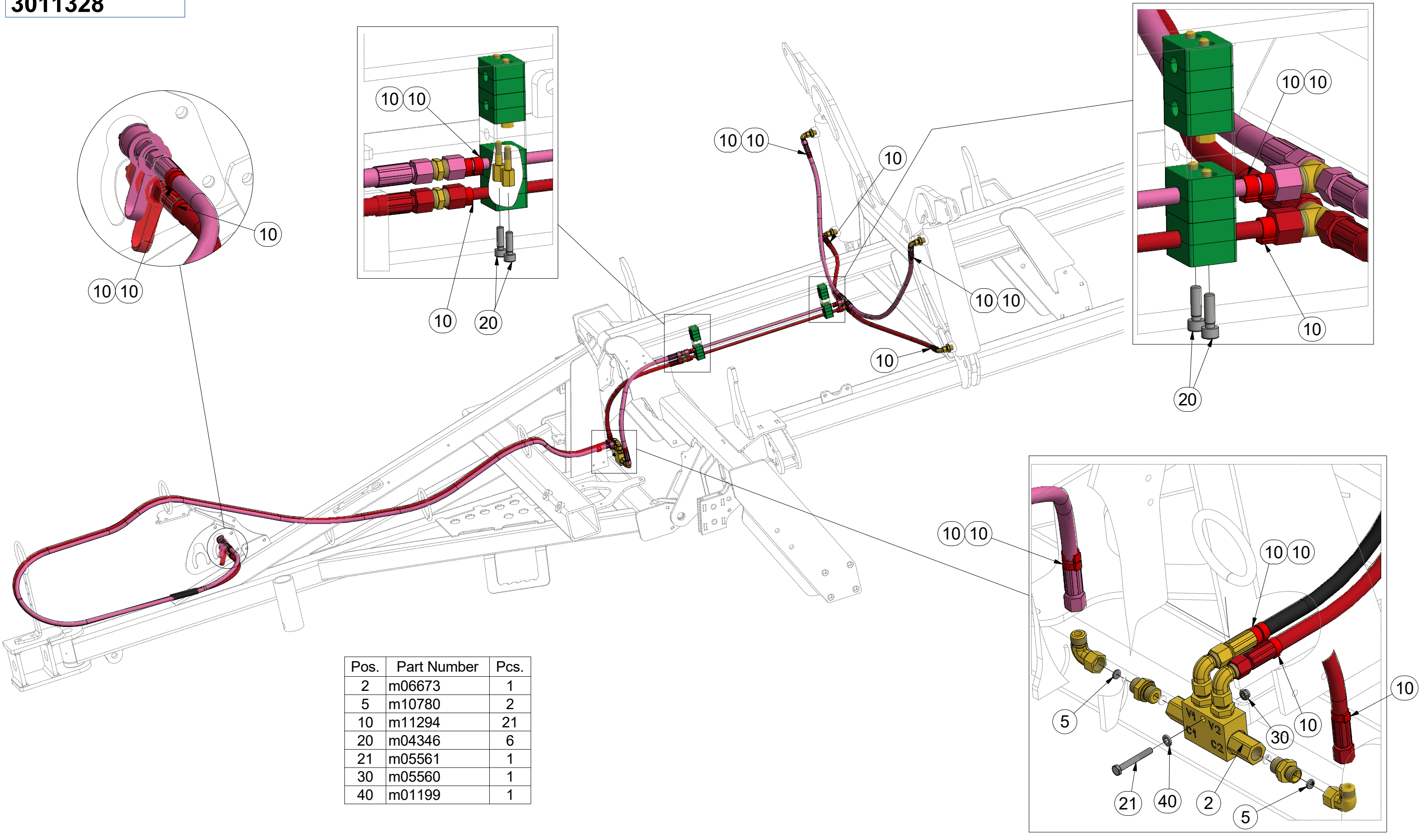

ⒸZ HYDRAULICKÝ ROZVOD NÁPRAVY

Ⓓ HYDRAULISCHE VERTEILUNG ACHSE

Ⓕ CONDUIT HYDRAULIQUE DE L'ESSIEU

ⒸB HYDRAULIC AXLE DISTRIBUTION

ⒸR ГИДРАВЛИЧЕСКОЕ РАСПРЕДЕЛЕНИЕ ОСИ

ⒸL HYDRAULICZNY PRZEWÓD OSI



m17907

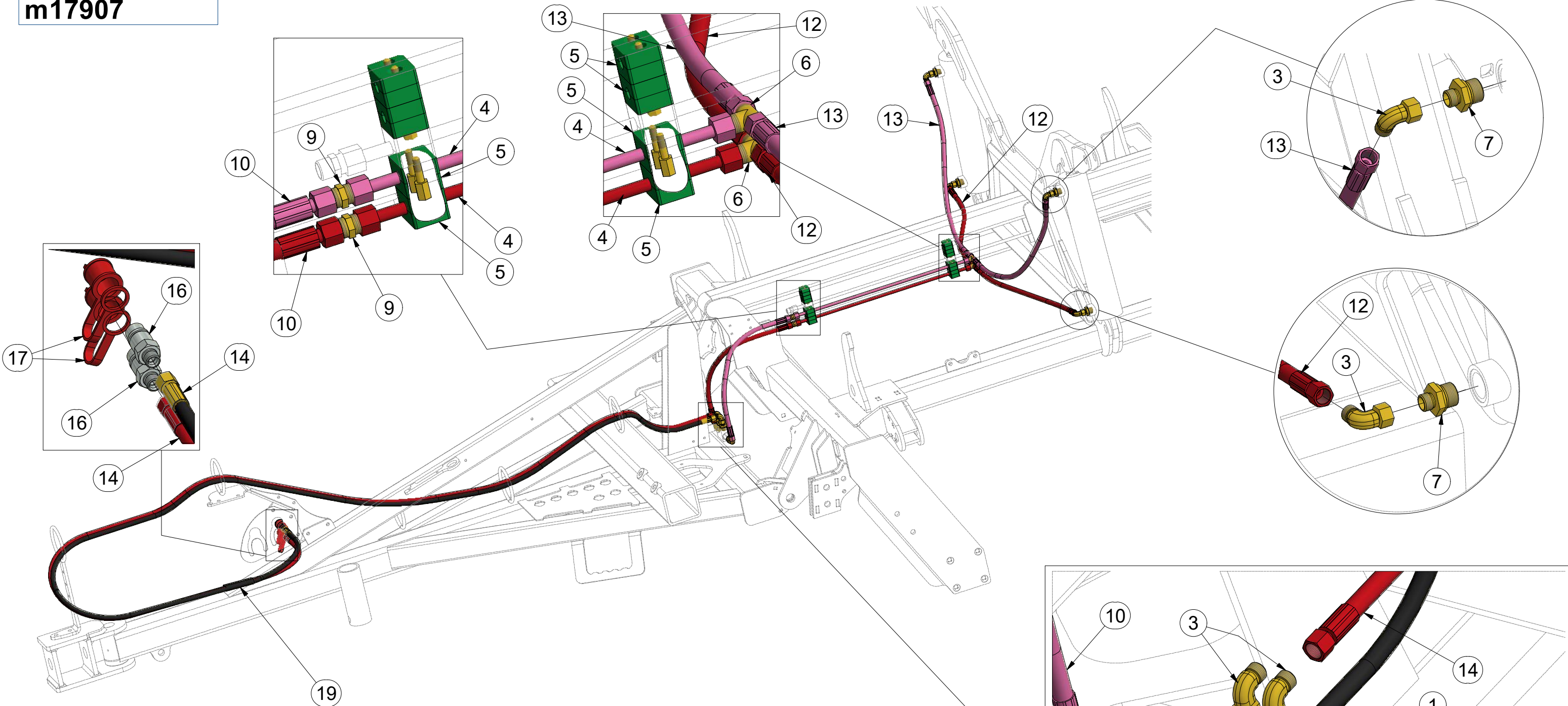

| Pos. | Part Number | Pcs. | Pos. | Part Number | Pcs. |
|------|-------------|------|------|-------------|------|
| 1 | m06528 | 4 | 10 | m03713 | 4 |
| 3 | m06803 | 8 | 12 | m07909 | 2 |
| 4 | m03975 | 2 | 13 | m07646 | 2 |
| 5 | m04009 | 10 | 14 | m04087 | 2 |
| 6 | m03889 | 4 | 16 | m03849 | 4 |
| 7 | m09934 | 8 | 17 | m04022 | 2 |
| 9 | m03213 | 4 | 19 | m11183 | 2 |

HYDRAULIC COMPONENTS:
M16 x 1,5 - 60Nm
M22 x 1,5 - 140Nm
G 3/8 - 95 Nm

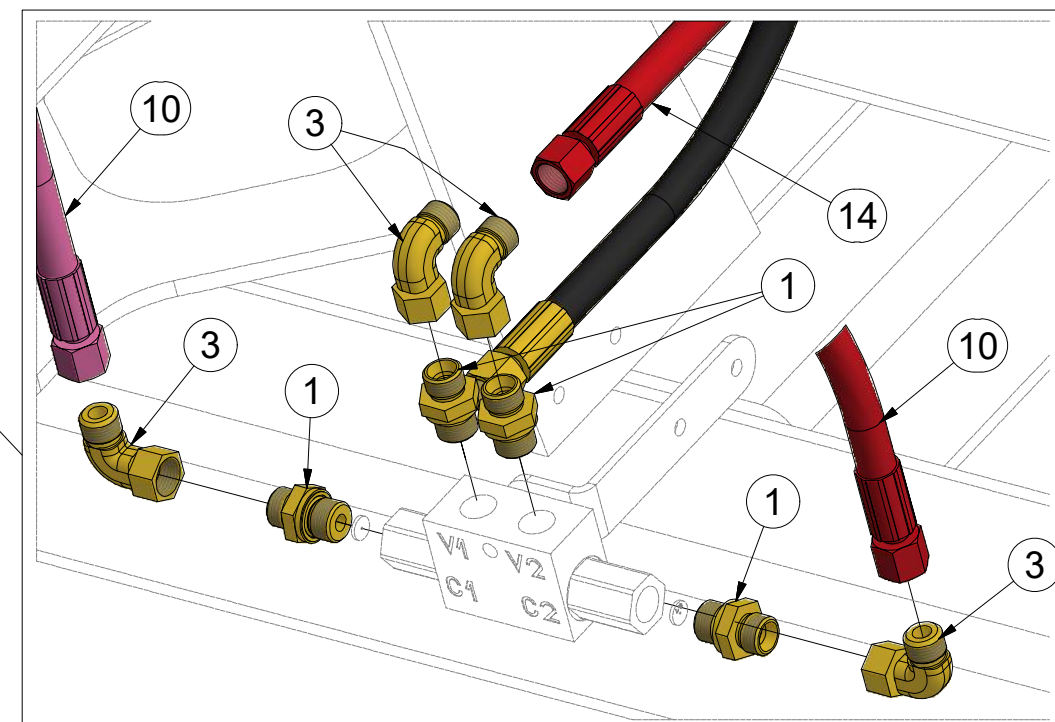

Ⓒ CZ OJ T3

Ⓓ DEICHSEL T3

Ⓕ TIMON T3

Ⓖ GB TOW BAR T3

Ⓡ RU ДЫШЛО T3

Ⓟ PL DYSZEL T3



3012414

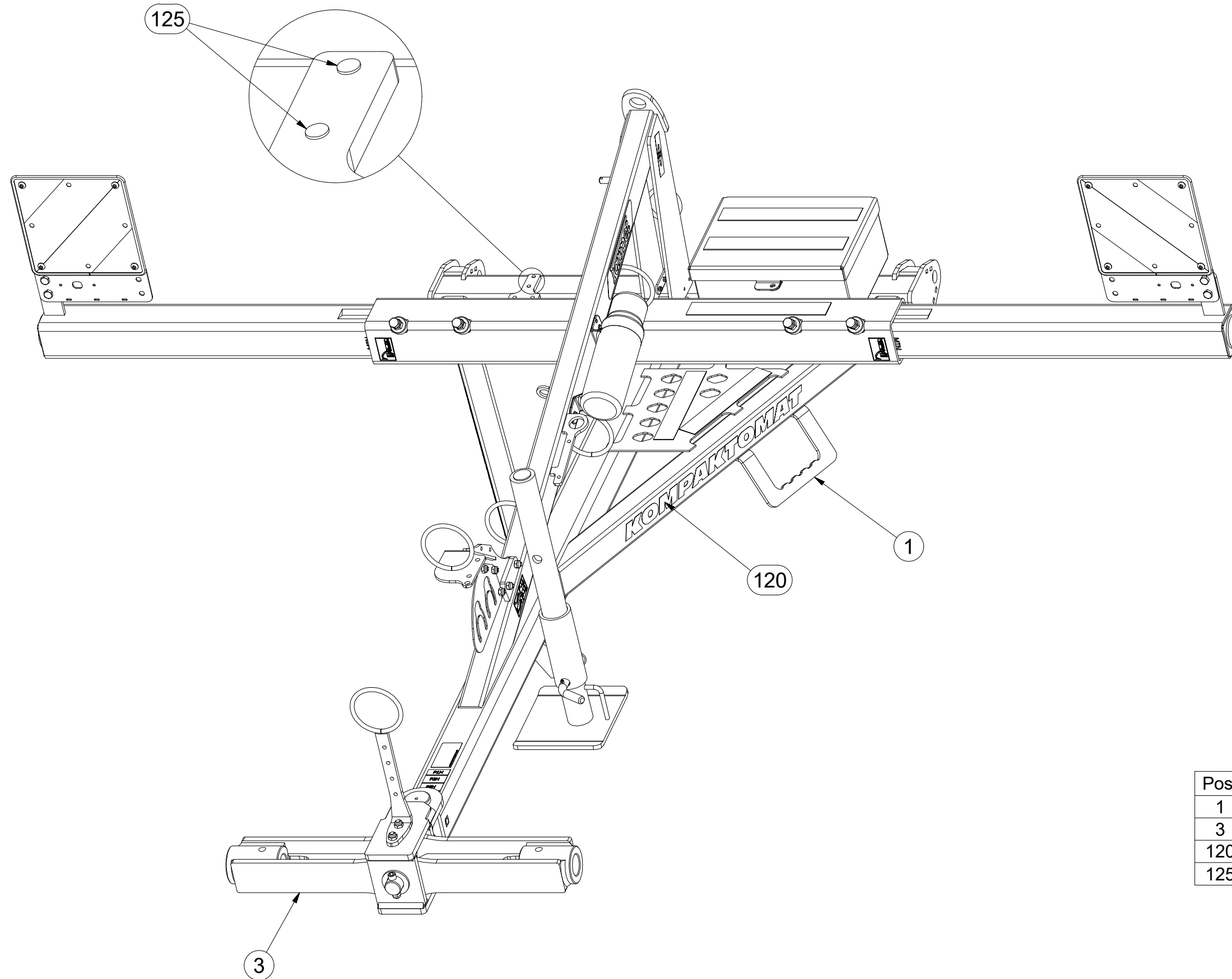

| Pos. | Part Number | Pcs. |
|------|-------------|------|
| 1 | 2001206 | 1 |
| 3 | 3003787 | 1 |
| 120 | m18866 | 1 |
| 125 | m11099 | 2 |

Ⓒ CZ OJ T3

Ⓓ DEICHSEL T3

Ⓕ TIMON T3

Ⓖ GB TOW BAR T3

Ⓡ RU ДЫШЛО T3

Ⓟ PL DYSZEL T3



3012414

| Pos. | Part Number | Pcs. | Pos. | Part Number | Pcs. |
|------|---------------|------|------|-------------|------|
| 1 | 2001206 | 1 | 72 | m04613 | 2 |
| 2 | 3009637 | 1 | 74 | m03926 | 2 |
| 3 | 3003787 | 1 | 75 | m03681 | 3 |
| 4 | 4003744 | 2 | 76 | m14008 | 2 |
| 5 | 4008049 | 1 | 86 | m03775 | 5 |
| 6 | 4014570 | 1 | 88 | m04301 | 8 |
| 10 | 8000647-40207 | 1 | 89 | m01306 | 4 |
| 11 | 4012205 | 1 | 90 | m02533 | 1 |
| 13 | 3012460 | 1 | 101 | m03866 | 1 |
| 15 | 4019191 | 1 | 102 | 4013139 | 2 |
| 17 | 4008679 | 1 | 110 | m10451 | 1 |
| 30 | m10454 | 1 | 115 | m03959 | 1 |

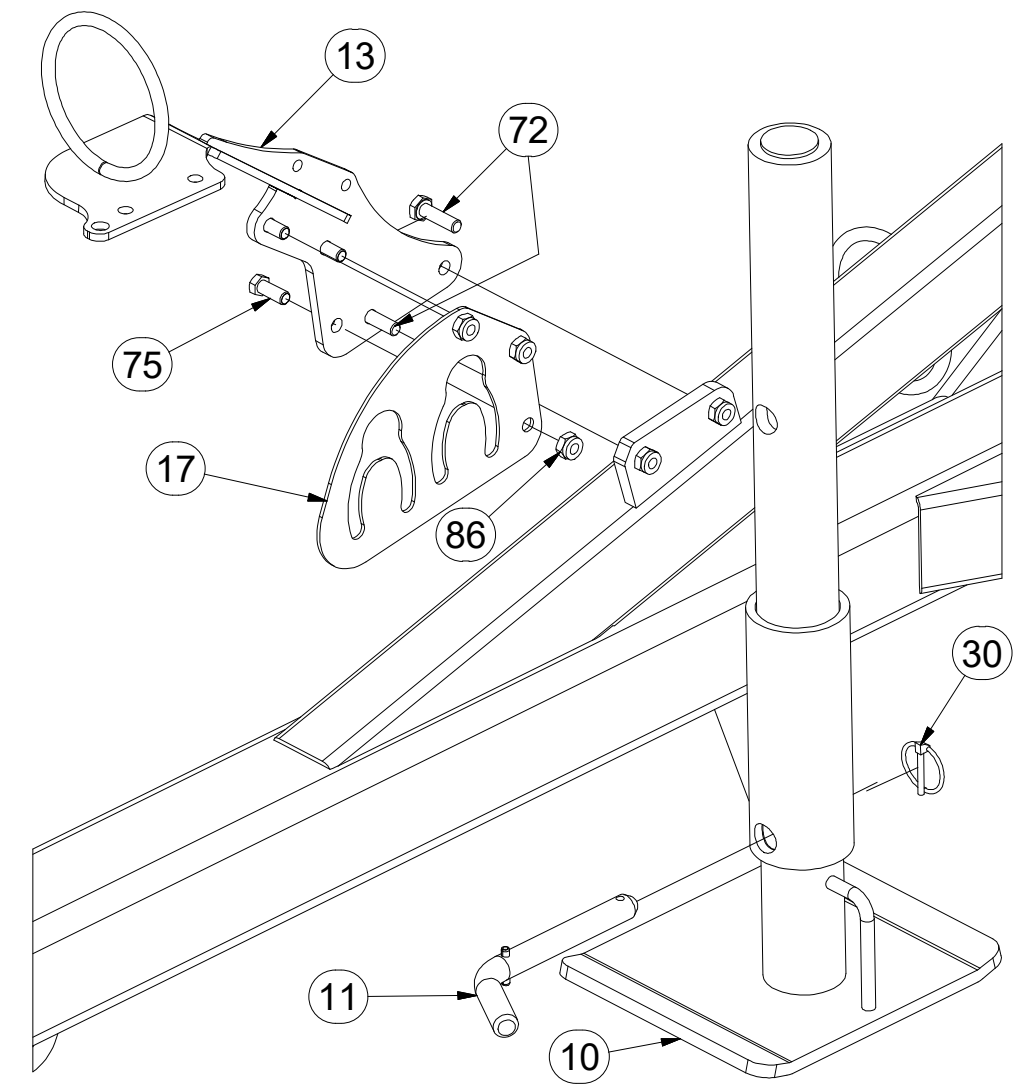
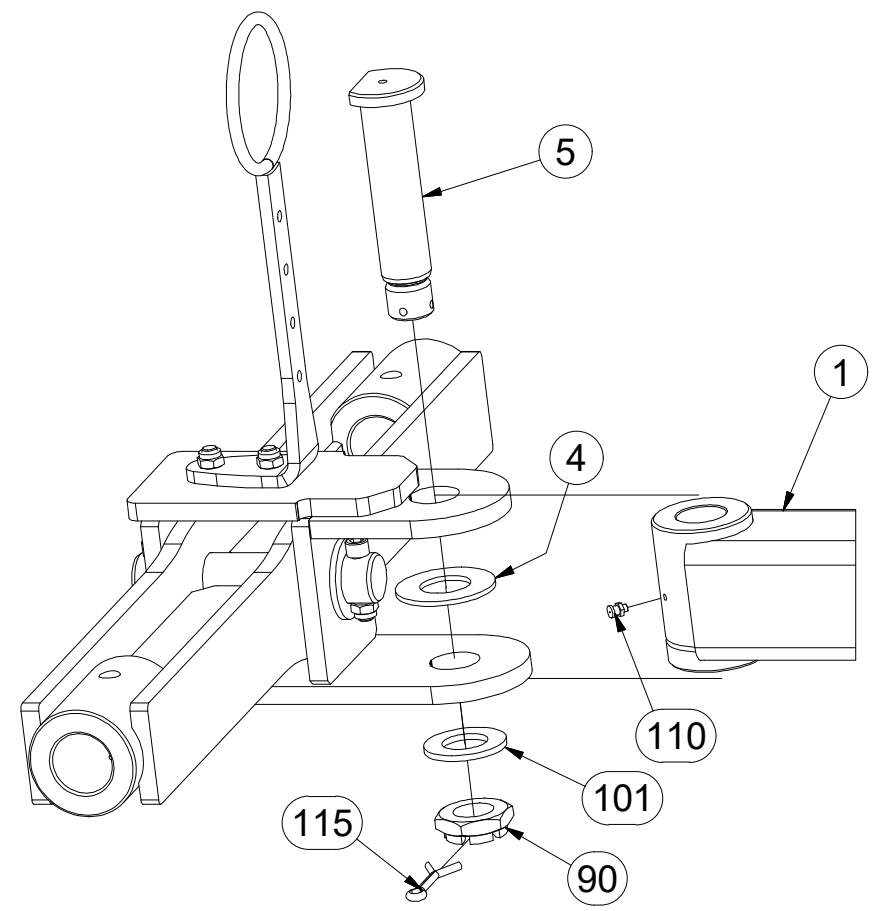
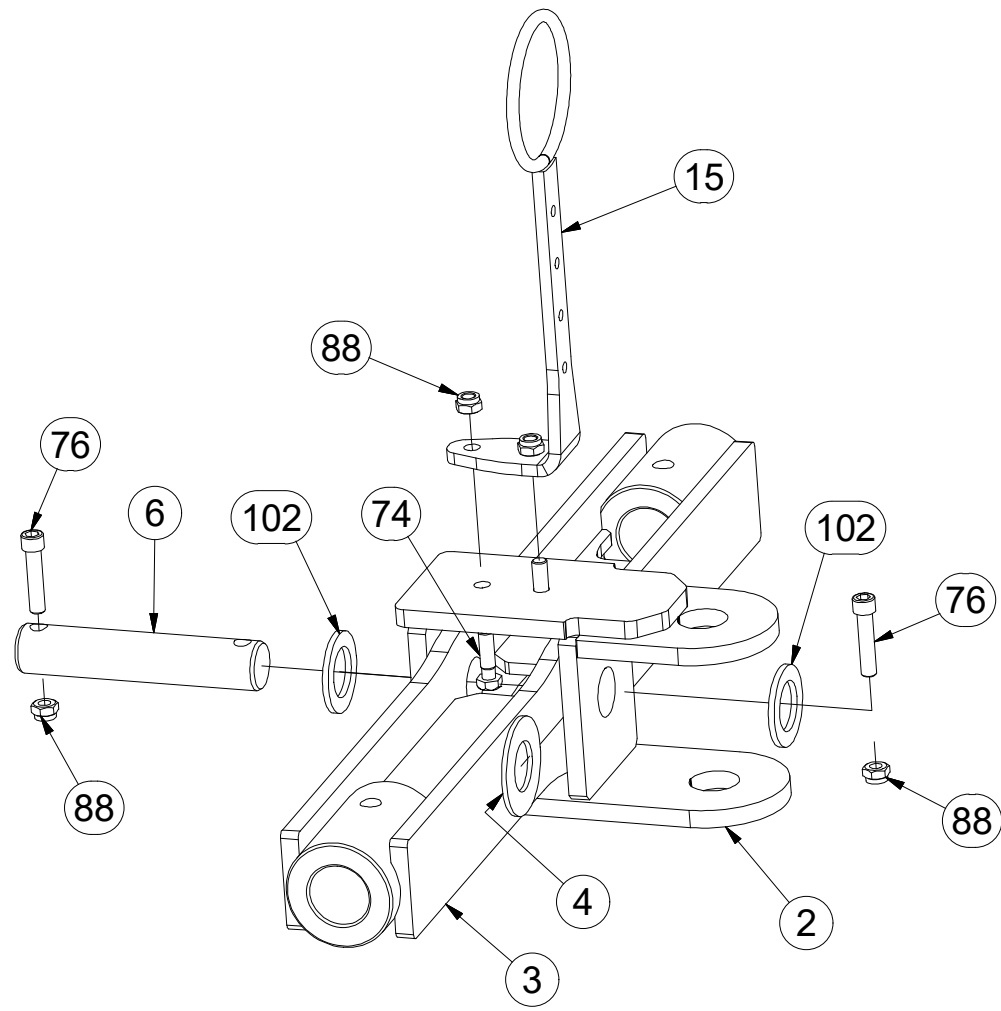
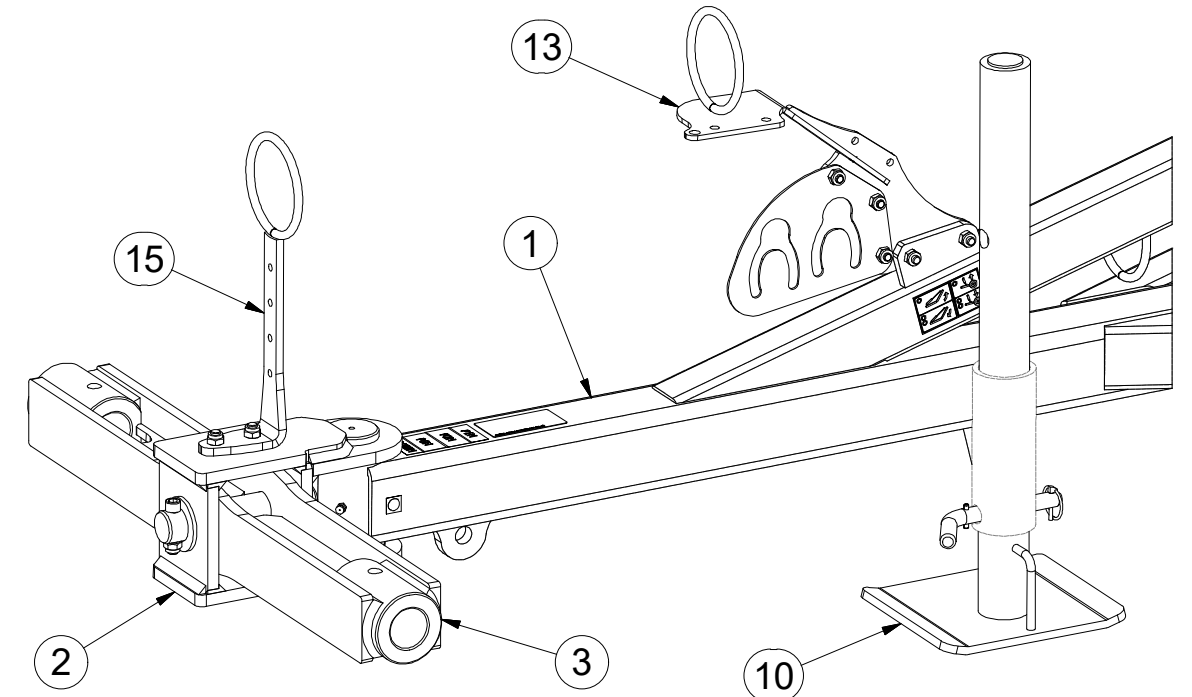

ⒸZ OJ T3

Ⓓ DEICHSEL T3

Ⓕ TIMON T3

ⒼB TOW BAR T3

ⒺR ДЫШЛО T3

ⒻL DYSZEL T3



3012414

| Pos. | Part Number | Pcs. |
|------|-------------|------|
| 1 | 2001206 | 1 |
| 7 | 4019255 | 2 |
| 8 | 4025088 | 1 |
| 9 | 4025089 | 1 |
| 12 | m12296 | 1 |
| 14 | 4013461 | 1 |
| 31 | m15900 | 1 |
| 50 | m02579 | 2 |
| 70 | m01074 | 2 |
| 71 | m01092 | 3 |
| 73 | m04039 | 4 |
| 77 | m02254 | 4 |
| 78 | m16453 | 2 |
| 85 | m05560 | 4 |
| 87 | m04503 | 3 |
| 88 | m04301 | 8 |
| 89 | m01306 | 4 |
| 100 | m07936 | 3 |
| 103 | m16612 | 4 |

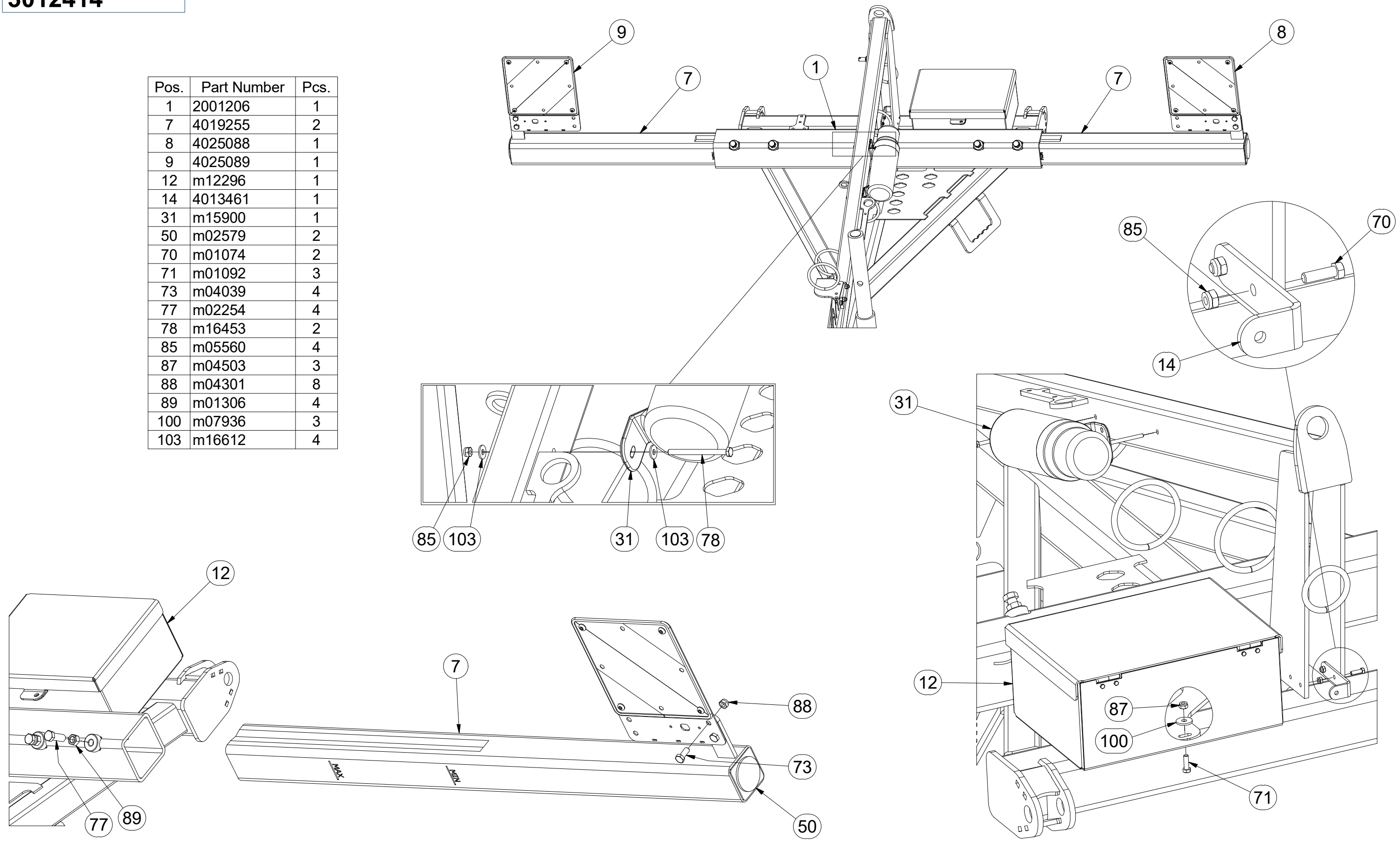

Ⓒ SAMOLEPKY STROJE

Ⓓ AUFKLEBER MASCHINEN

Ⓕ VOITURE MACHINES

Ⓖ STICKERS MACHINES

Ⓡ СТИКЕРЫ МАШИНЫ

Ⓟ NAKLEJKI MASZYNY



m18866

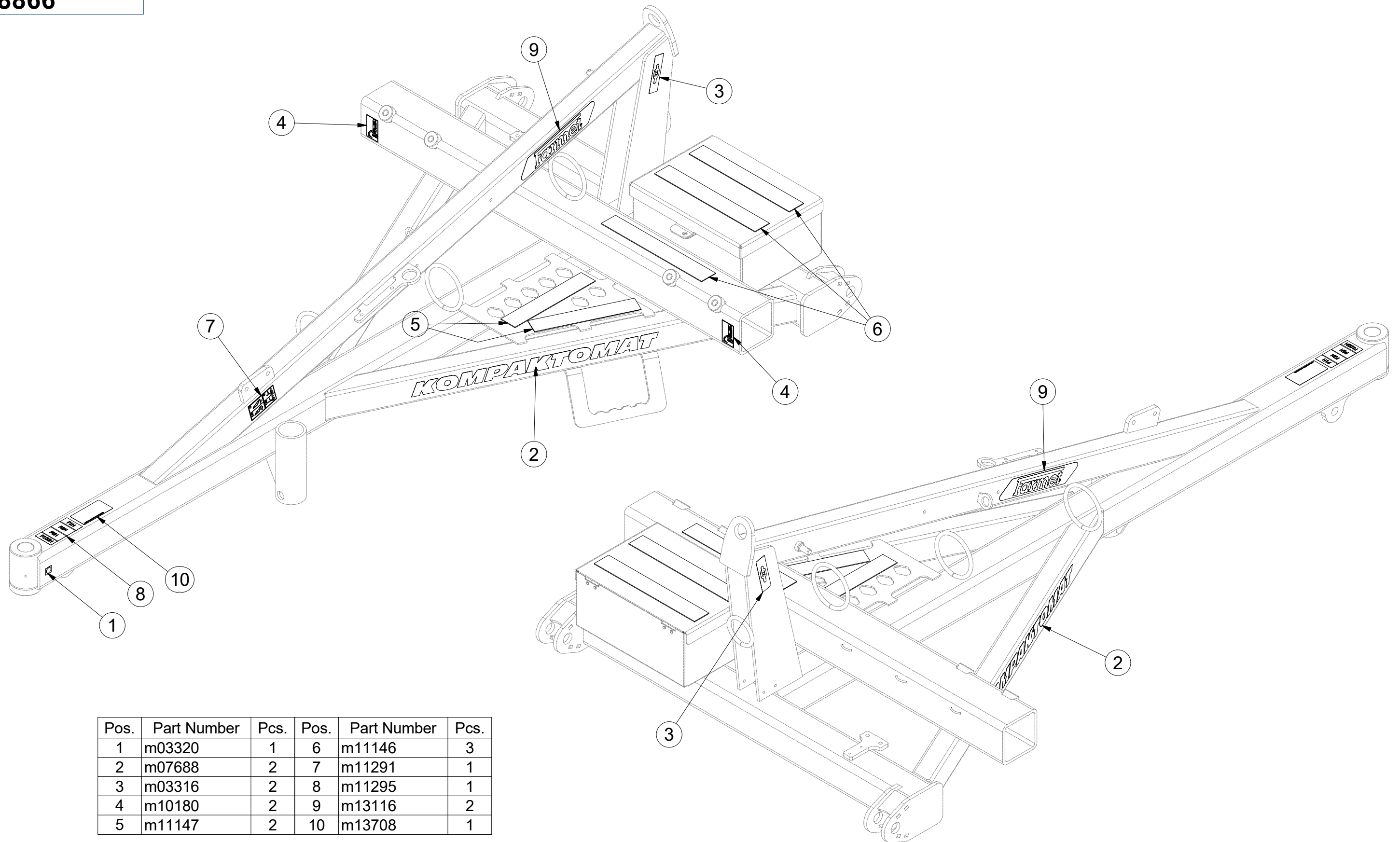

| Pos. | Part Number | Pcs. | Pos. | Part Number | Pcs. |
|------|-------------|------|------|-------------|------|
| 1 | m03320 | 1 | 6 | m11146 | 3 |
| 2 | m07688 | 2 | 7 | m11291 | 1 |
| 3 | m03316 | 2 | 8 | m11295 | 1 |
| 4 | m10180 | 2 | 9 | m13116 | 2 |
| 5 | m11147 | 2 | 10 | m13708 | 1 |

☞ SADA ČEPŮ TBZ 3

☞ BOLZENSATZ TBZ 3

☞ KIT D'EMBOUITS TBZ 3

3011605

☞ SET OF TBZ 3 PINS

☞ КОМПЛЕКТ ПАЛЬЦЕВ TBZ 3

☞ ZESTAW CZOPÓW TBZ 3

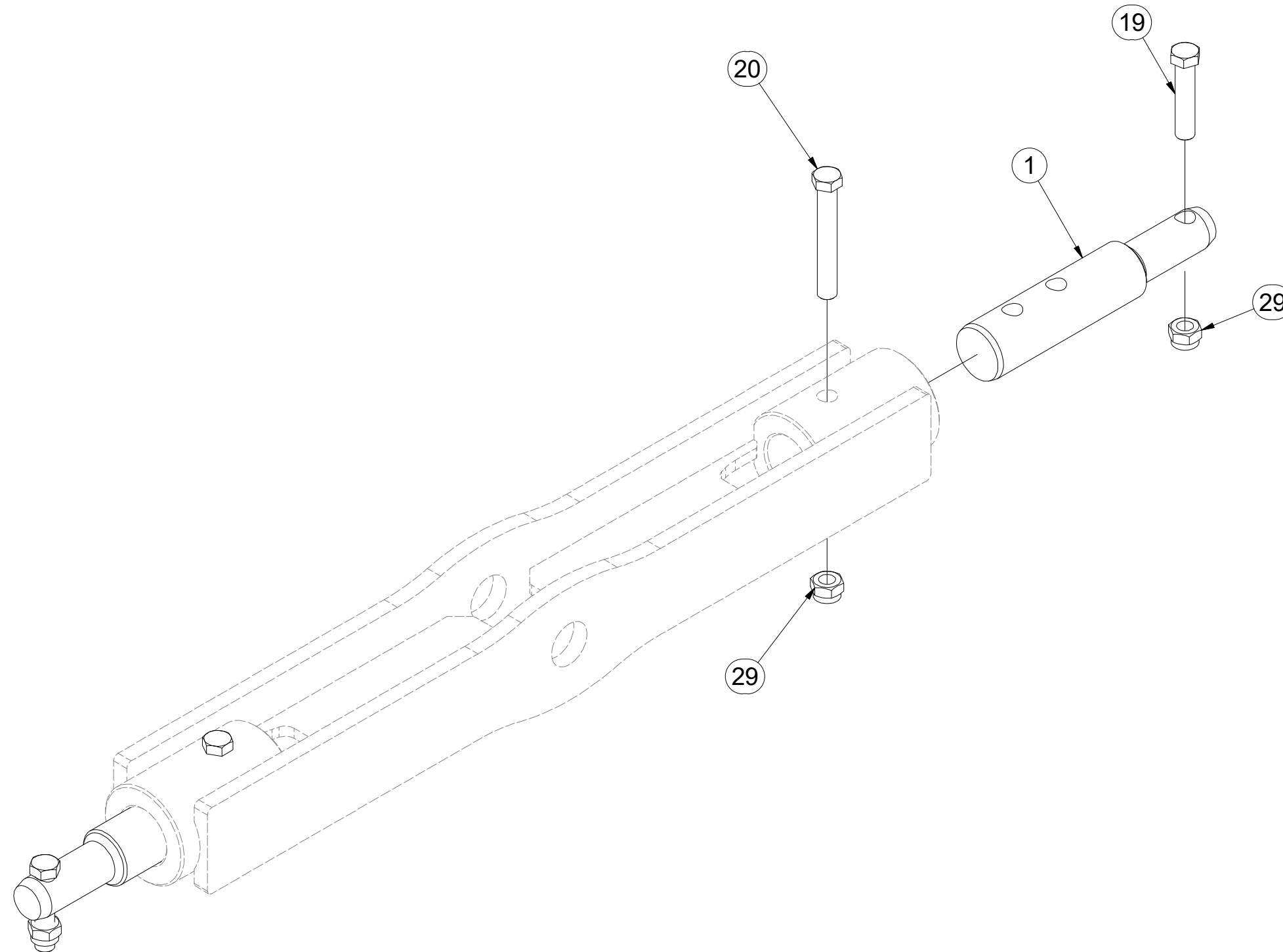
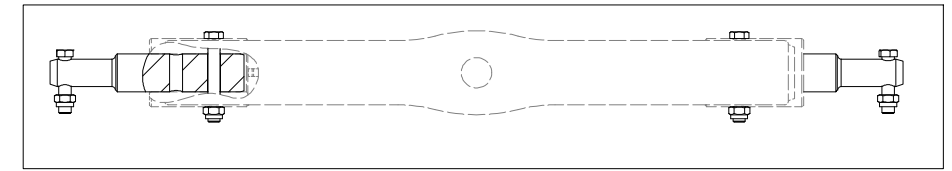

| Pos. | Part Number | Pcs. |
|------|-------------|------|
| 1 | 4023528 | 2 |
| 19 | m01133 | 2 |
| 20 | m02970 | 2 |
| 29 | m03683 | 4 |

ⒸZ ŘETĚZ
Ⓓ KETTE
Ⓕ CHAÎNE

ⒼB CHAIN
ⒺU ЦЕПЬ
ⒶL ŁAŃCUCH



4025903

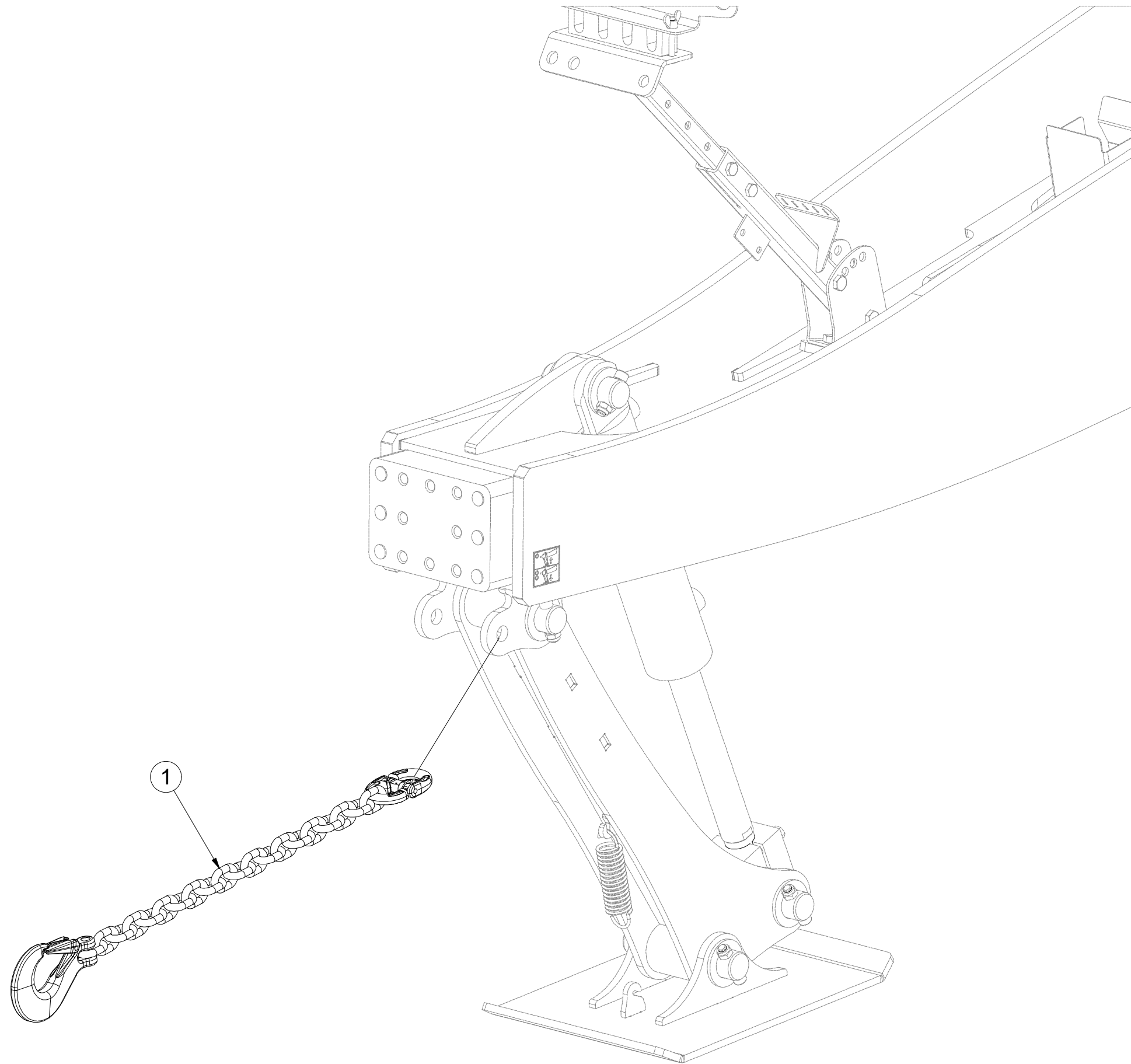

| Pos. | Part Number | Pcs. |
|------|-------------|------|
| 1 | 9005854 | 1 |

Ⓒ CZ TERČ PŘEDNÍ LEVÝ

Ⓓ D SCHILD, VORDERES, LINKES

Ⓕ F CIBLE AVANT GAUCHE

Ⓖ GB LEFT FRONT DISC

Ⓡ RU ЩИТОК ПЕРЕДНИЙ ЛЕВЫЙ

Ⓟ PL TARCZA PRZEDNIA LEWA



4025088

| Pos. | Part Number | Pcs. |
|------|-------------|------|
| 1 | 4025090 | 1 |
| 2 | m18855 | 1 |
| 3 | 9005707 | 1 |
| 10 | m16637 | 4 |
| 15 | m03775 | 4 |
| 20 | m01209 | 4 |

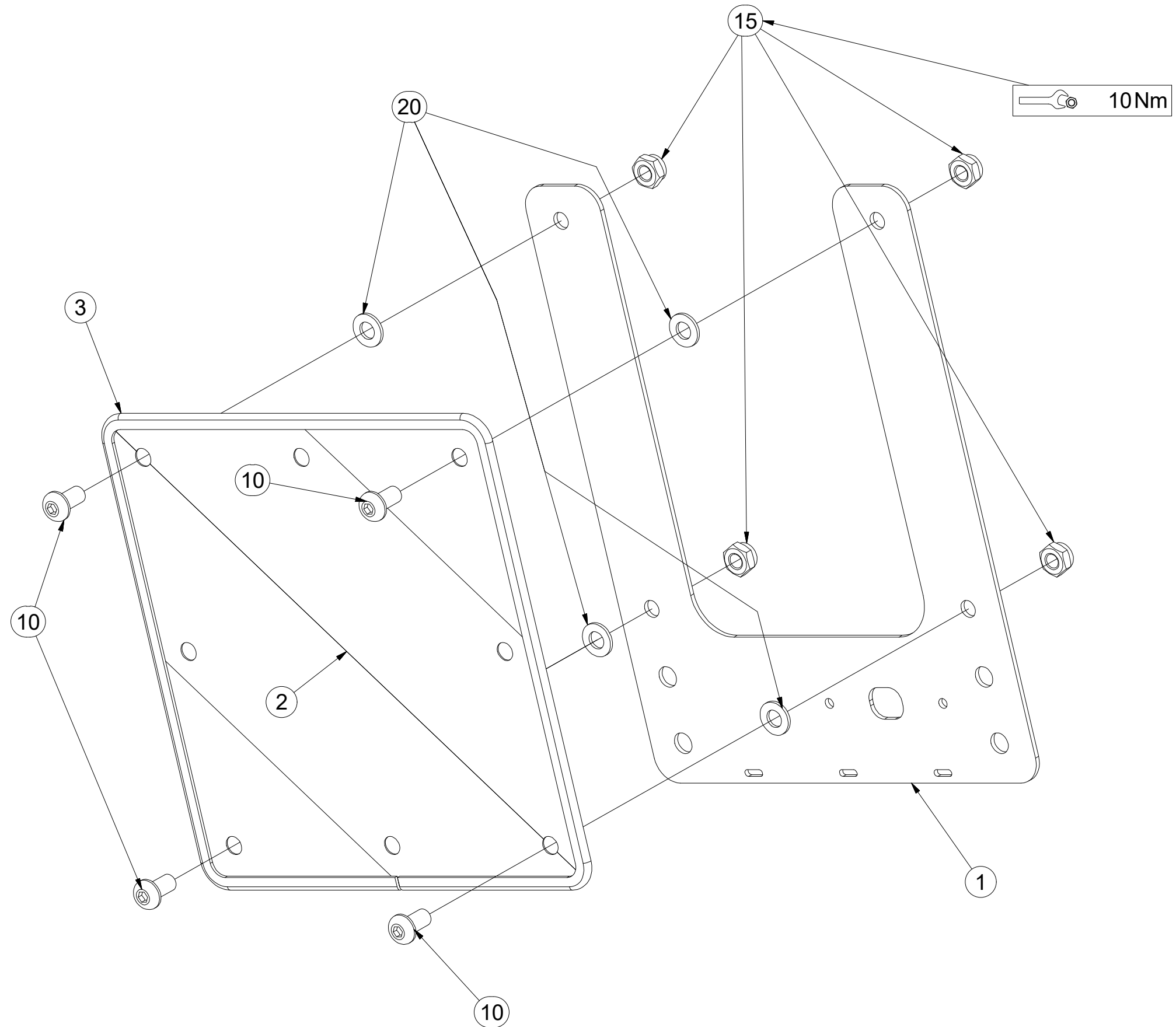

Ⓒ CZ TERČ PŘEDNÍ PRAVÝ

Ⓓ D SCHILD, VORDERES, RECHTES

Ⓕ F CIBLE AVANT DROITE

Ⓖ GB RIGHT FRONT DISC

Ⓔ RU ЩИТОК ПЕРЕДНИЙ ПРАВЫЙ

Ⓟ PL TARCZA PRZEDNIA PRAWA



4025089

| Pos. | Part Number | Pcs. |
|------|-------------|------|
| 1 | 4025090 | 1 |
| 2 | m18855 | 1 |
| 3 | 9005707 | 1 |
| 10 | m16637 | 4 |
| 15 | m03775 | 4 |
| 20 | m01209 | 4 |

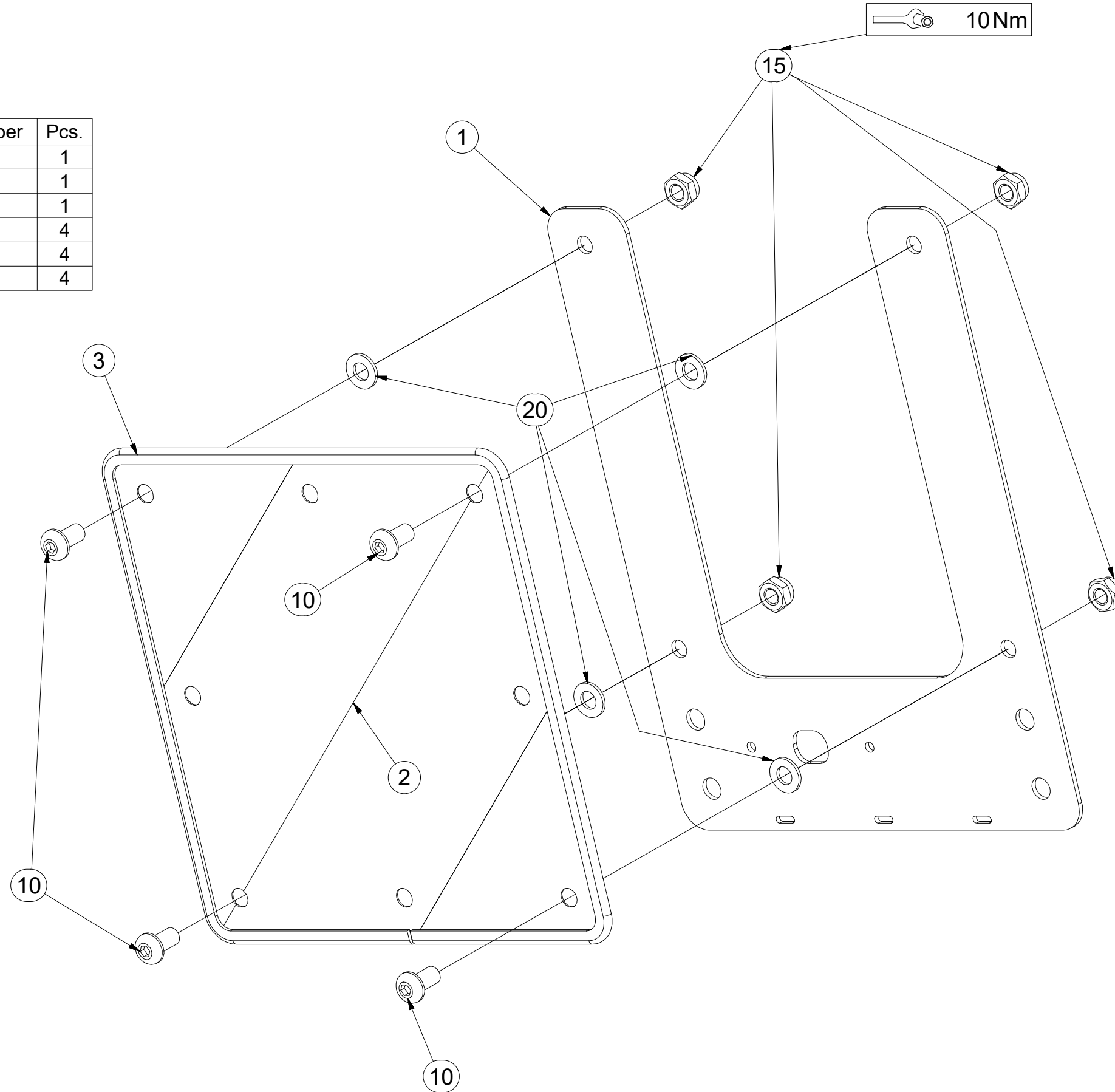

ⒸZ SADA KYPŘIČŮ STOP

Ⓓ SPURENLOCKERERSATZ

Ⓕ KIT DE CULTIVATEURS DE TRACES

3005535

ⒸB SET OF TRACK CULTIVATORS

Ⓔ КОМПЛЕКТ РЫХЛИТЕЛЕЙ КОЛЕИ

Ⓖ ZESTAW SPULCHNIACZY ŚLADÓW

Farmet

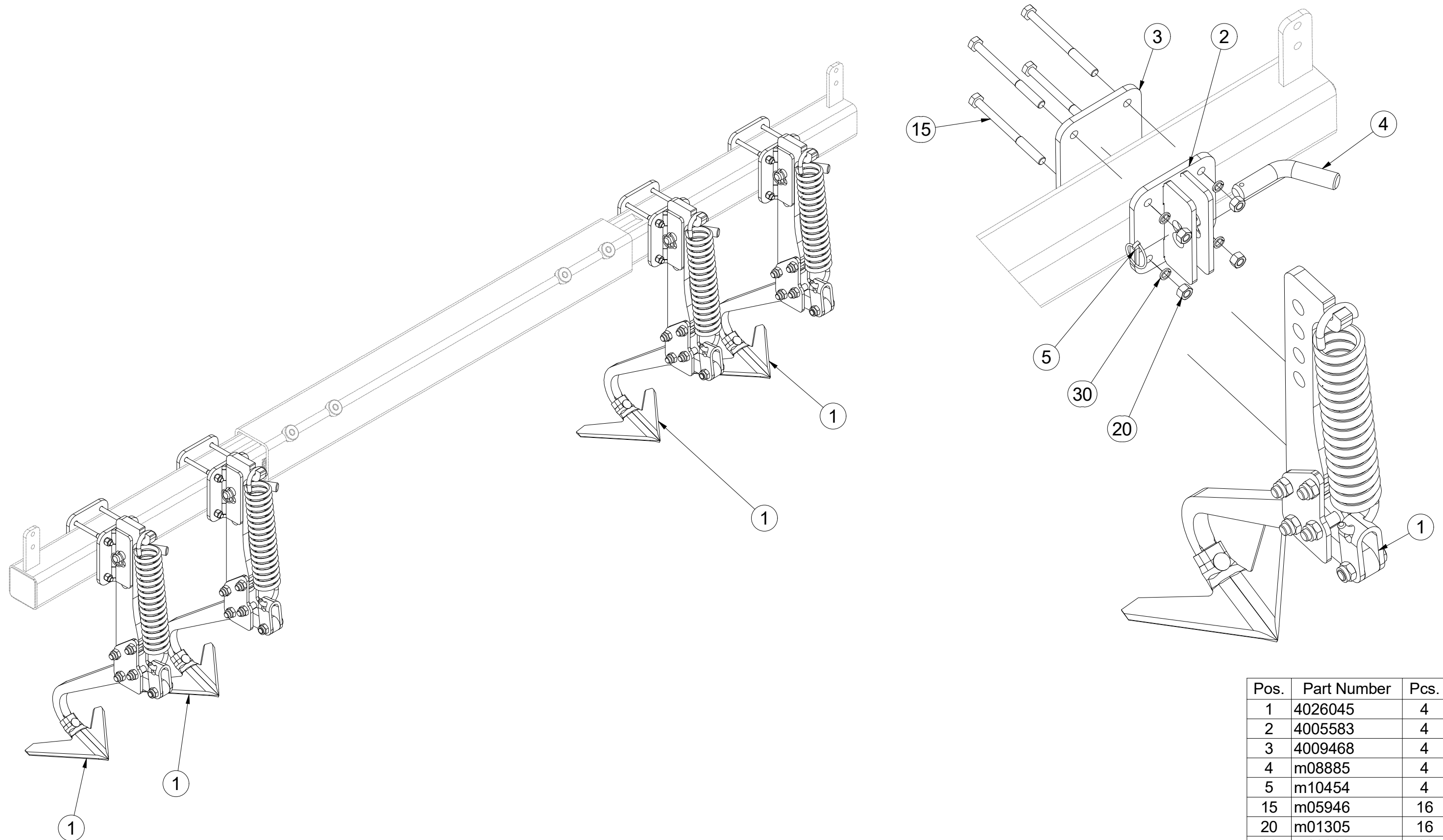

| Pos. | Part Number | Pcs. |
|------|-------------|------|
| 1 | 4026045 | 4 |
| 2 | 4005583 | 4 |
| 3 | 4009468 | 4 |
| 4 | m08885 | 4 |
| 5 | m10454 | 4 |
| 15 | m05946 | 16 |
| 20 | m01305 | 16 |
| 30 | m03988 | 16 |

Ⓒ KYPŘIČ STOP

Ⓓ SPURENLOCKERER

Ⓕ CULTIVATEUR DES TRACES

Ⓖ TRACK CULTIVATOR

Ⓡ РЫХЛИТЕЛЬ КОЛЕИ

Ⓟ SPULCHNIARKA STÓP

Farmet

4026045

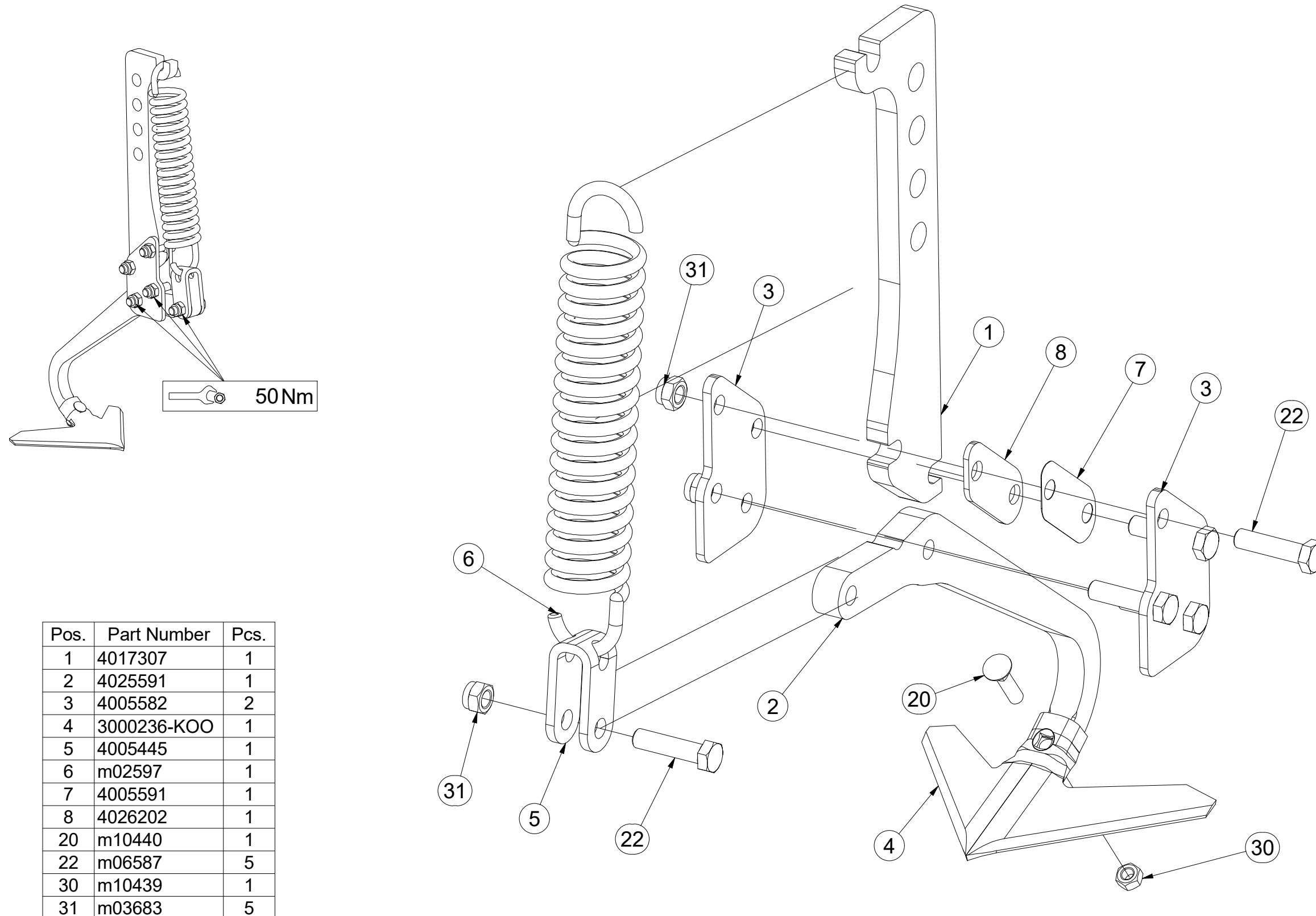

| Pos. | Part Number | Pcs. |
|------|-------------|------|
| 1 | 4017307 | 1 |
| 2 | 4025591 | 1 |
| 3 | 4005582 | 2 |
| 4 | 3000236-KOO | 1 |
| 5 | 4005445 | 1 |
| 6 | m02597 | 1 |
| 7 | 4005591 | 1 |
| 8 | 4026202 | 1 |
| 20 | m10440 | 1 |
| 22 | m06587 | 5 |
| 30 | m10439 | 1 |
| 31 | m03683 | 5 |

ⒸZ SADA PŘEDNÍCH SMYKŮ

Ⓓ SATZ VORDERE ACKERSCHLEPPEN

Ⓕ KIT DE NIVELEURS AVANT

ⒼB SET OF FRONT LEVELLING BARS

ⒺU КОМПЛЕКТ ПЕРЕДНИХ БОРОН

ⒶL ZESTAW PRZEDNICH WŁÓK

Farmet

3006591

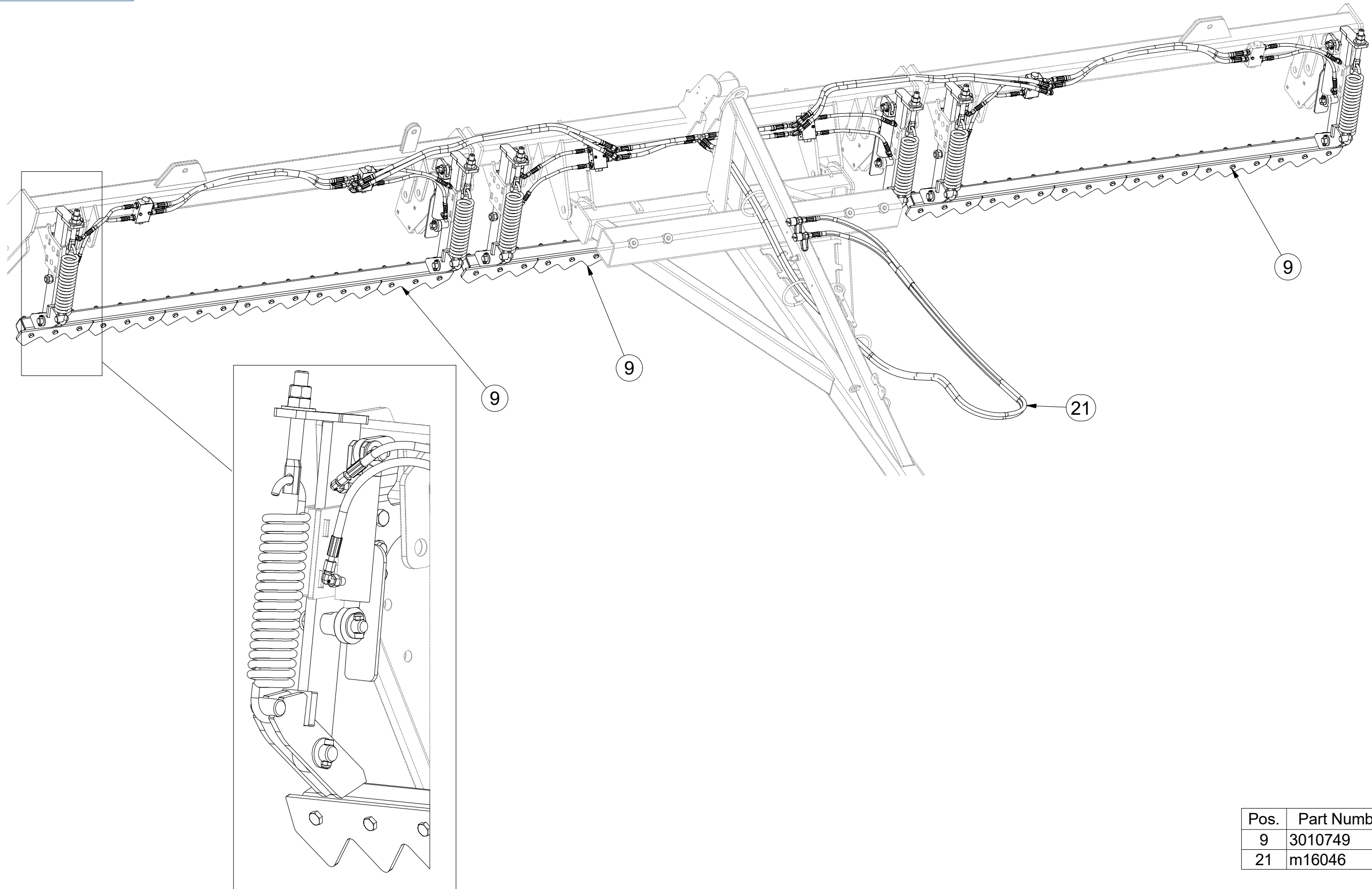

| Pos. | Part Number | Pcs. |
|------|-------------|------|
| 9 | 3010749 | 3 |
| 21 | m16046 | 1 |

Ⓒ SADA PŘEDNÍCH SMYKŮ

Ⓓ SATZ VORDERE ACKERSCHLEPPEN

Ⓕ KIT DE NIVELEURS AVANT

Ⓖ SET OF FRONT LEVELLING BARS

Ⓡ КОМПЛЕКТ ПЕРЕДНИХ БОРОН

Ⓢ ZESTAW PRZEDNICH WŁÓK



3006591

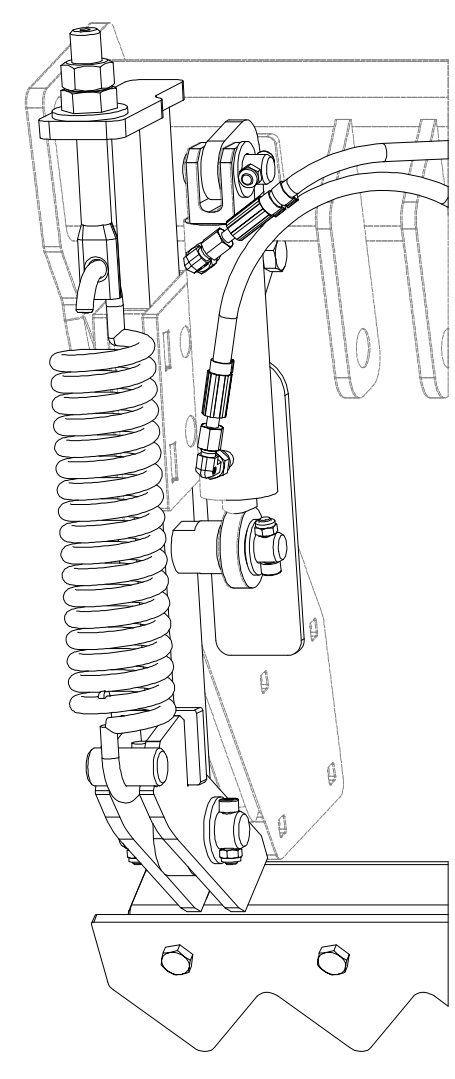

1

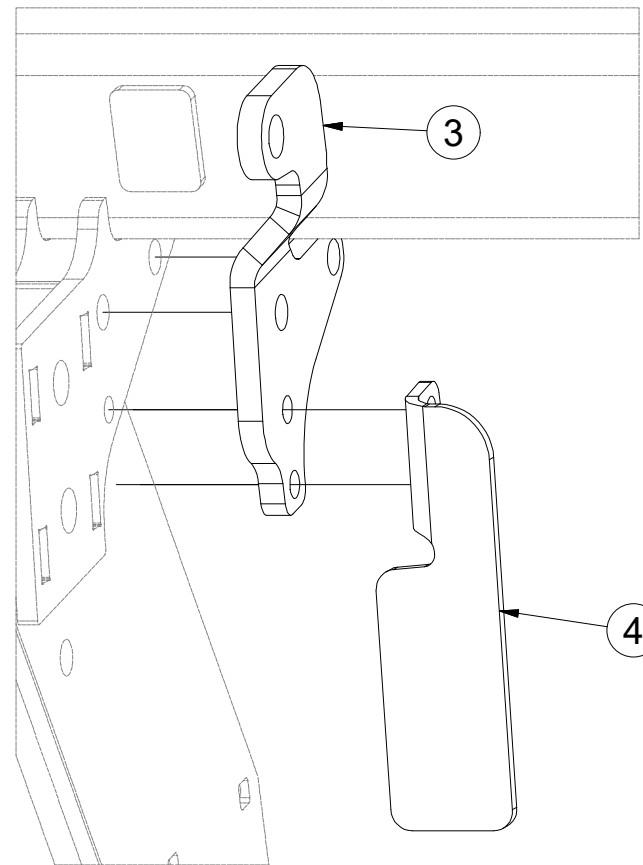

2

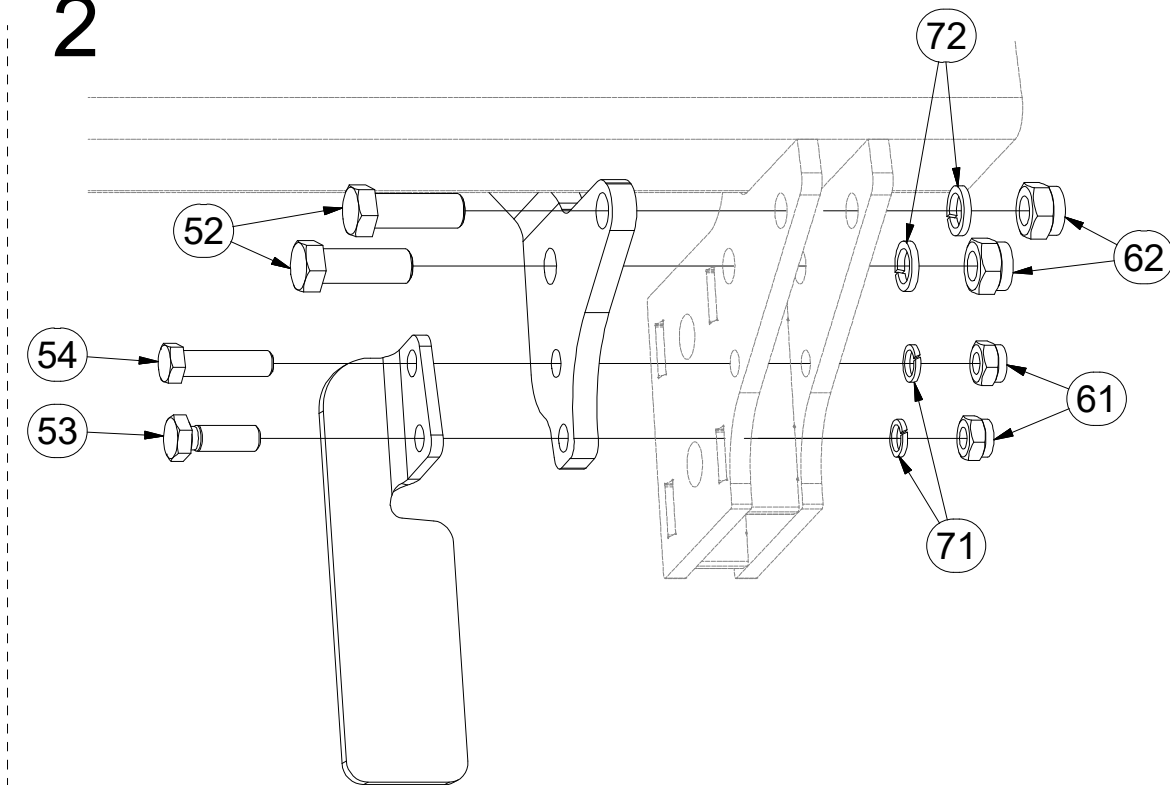

3

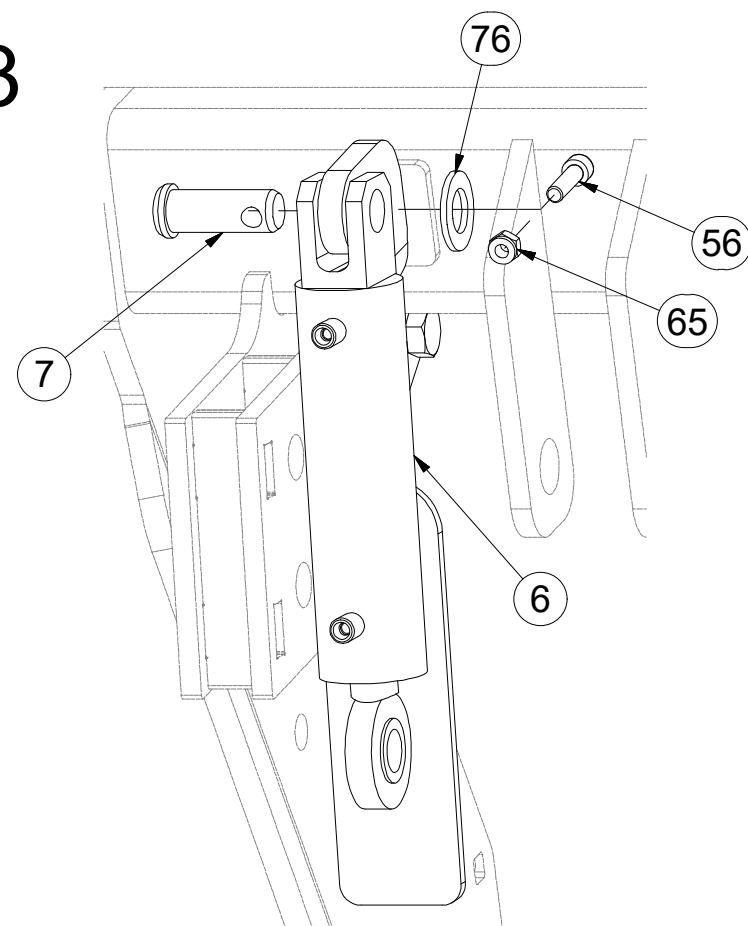

4

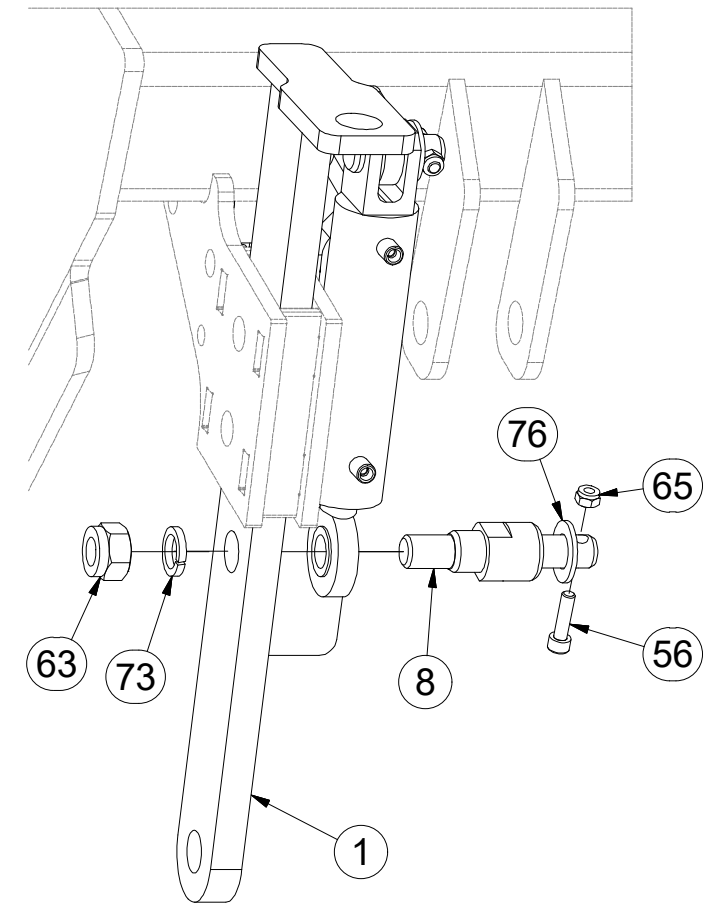

| Pos. | Part Number | Pcs. | Pos. | Part Number | Pcs. |
|------|---------------|------|------|-------------|------|
| 1 | 3008688 | 6 | 56 | m09870 | 12 |
| 3 | 4010386 | 3 | 61 | m04301 | 12 |
| 4 | 4010388 | 3 | 62 | m03683 | 12 |
| 6 | 8000734-90007 | 6 | 63 | m05648 | 6 |
| 7 | 4015710 | 6 | 65 | m04503 | 24 |
| 8 | 4015712 | 6 | 71 | m03988 | 12 |
| 52 | m02254 | 12 | 72 | m02157 | 12 |
| 53 | m04343 | 6 | 73 | m01229 | 6 |
| 54 | m06077 | 6 | 76 | m03768 | 12 |

Ⓒ SADA PŘEDNÍCH SMYKŮ

Ⓓ SATZ VORDERE ACKERSCHLEPPEN

Ⓕ KIT DE NIVELEURS AVANT

Ⓖ SET OF FRONT LEVELLING BARS

Ⓡ КОМПЛЕКТ ПЕРЕДНИХ БОРОН

Ⓟ ZESTAW PRZEDNICH WŁÓK

Farmet

3006591

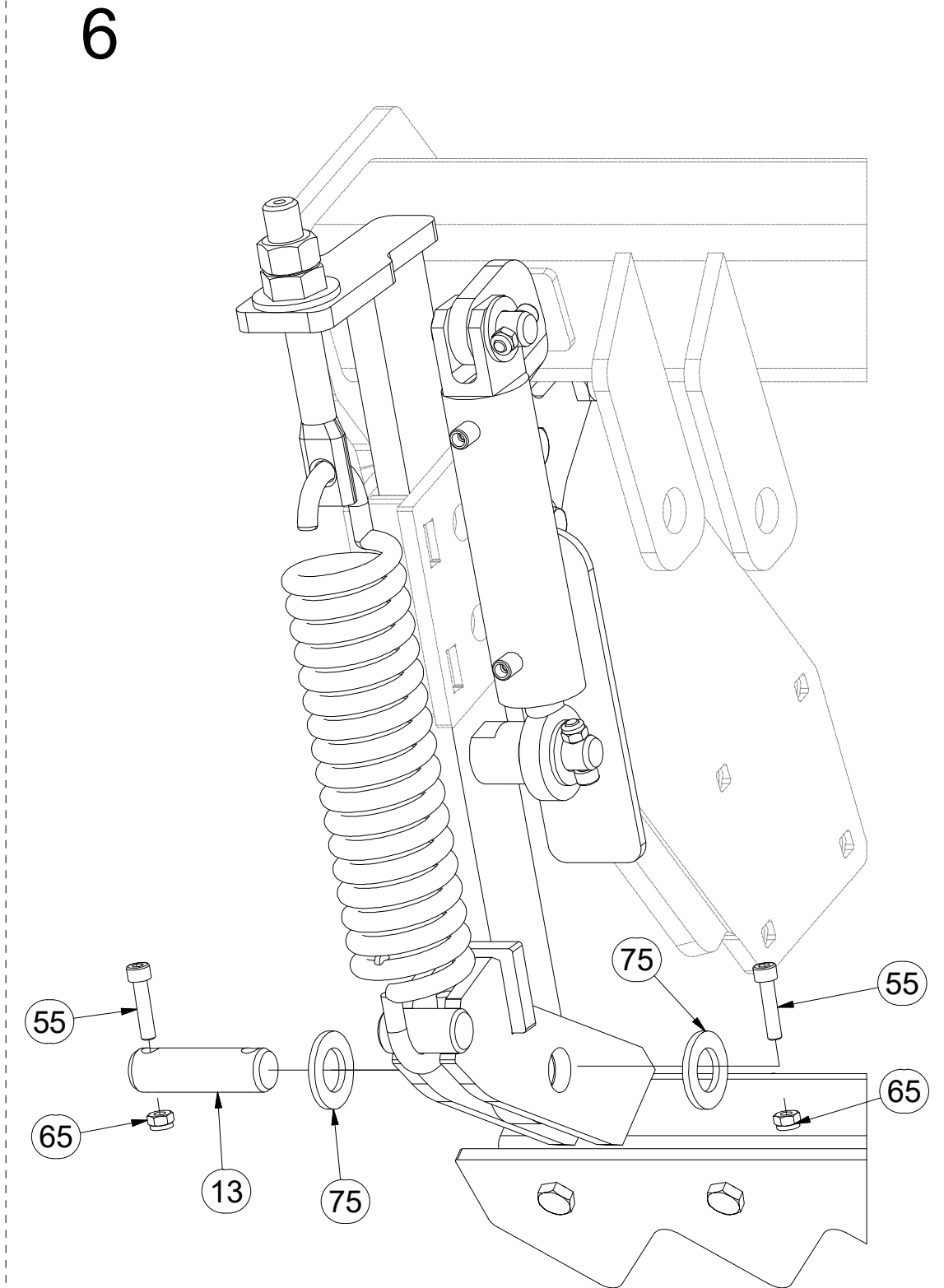
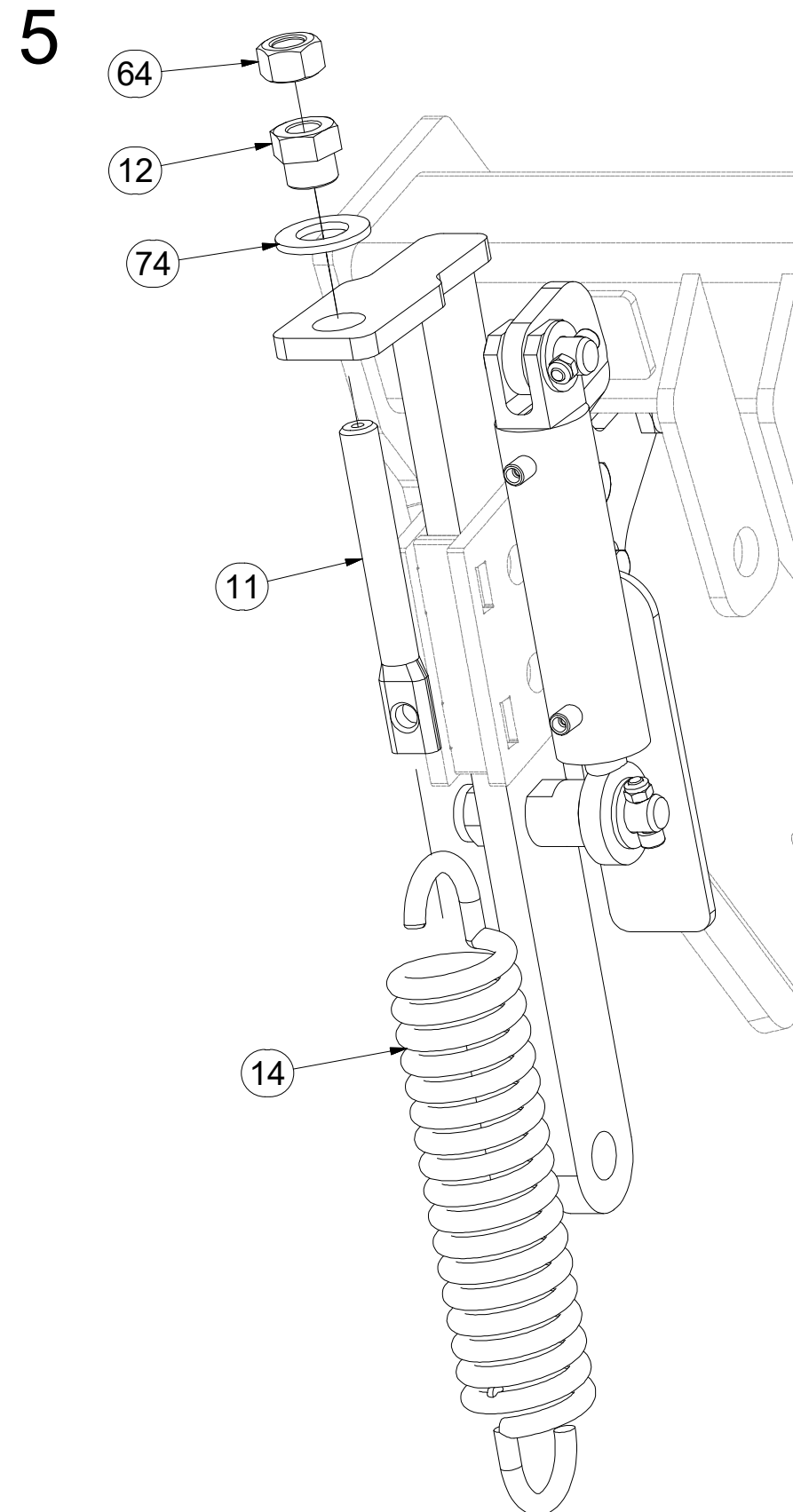
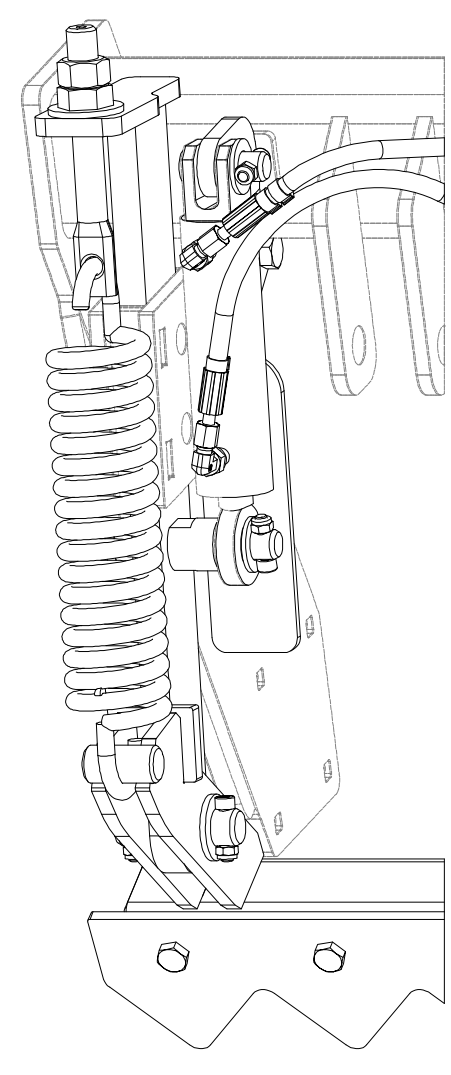

| Pos. | Part Number | Pcs. |
|------|-------------|------|
| 11 | 4003401 | 6 |
| 12 | 4000189 | 6 |
| 13 | 4010390 | 6 |
| 14 | m02597 | 6 |
| 55 | m09464 | 12 |
| 64 | m01307 | 6 |
| 65 | m04503 | 24 |
| 74 | m01225 | 6 |
| 75 | m14028 | 12 |

ⒸZ SADA PŘEDNÍCH SMYKŮ

Ⓓ SATZ VORDERE ACKERSCHLEPPEN

Ⓕ KIT DE NIVELEURS AVANT

ⒼB SET OF FRONT LEVELLING BARS

ⒺU КОМПЛЕКТ ПЕРЕДНИХ БОРОН

ⒽL ZESTAW PRZEDNICH WŁÓK



3006591

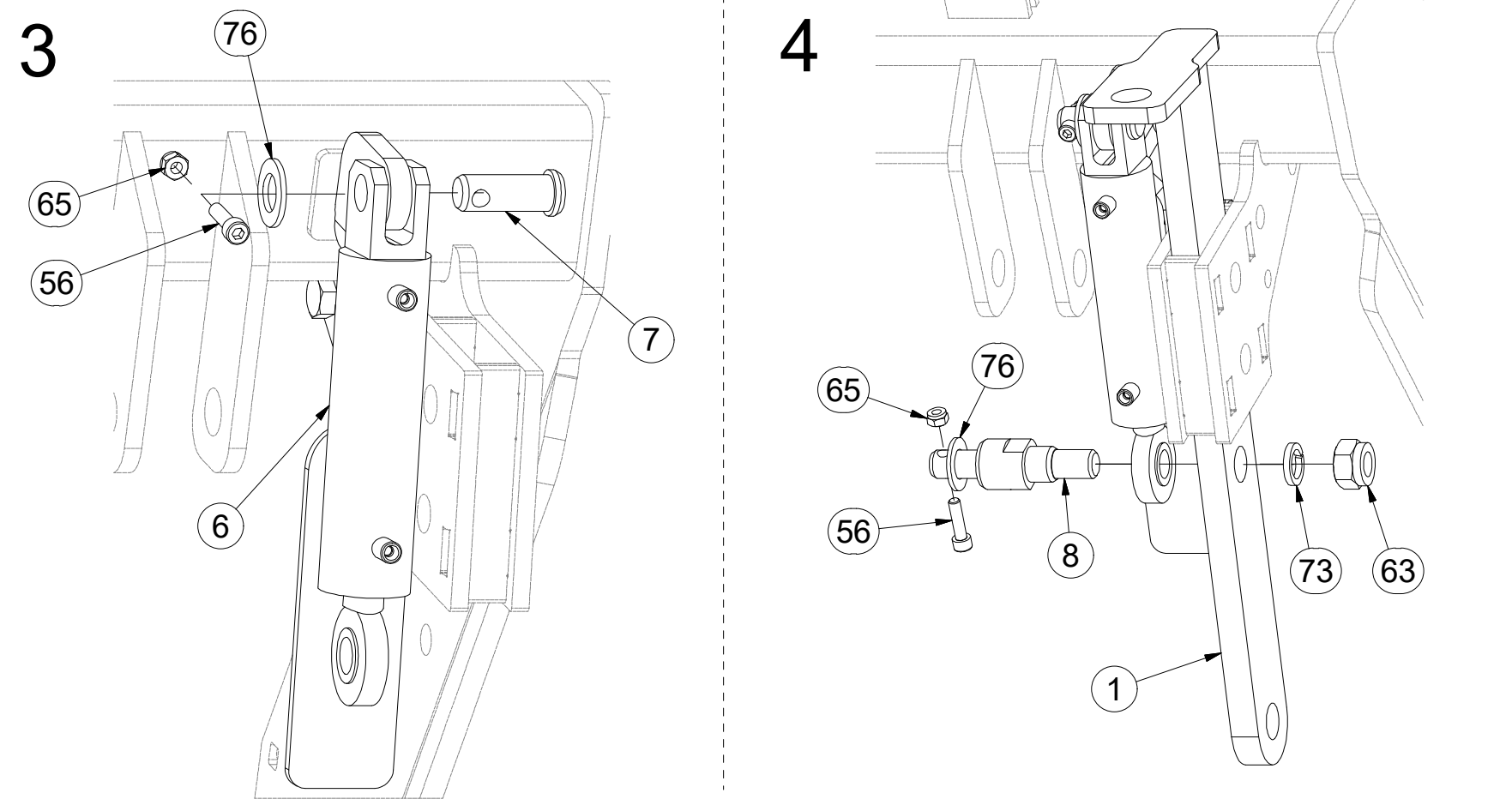
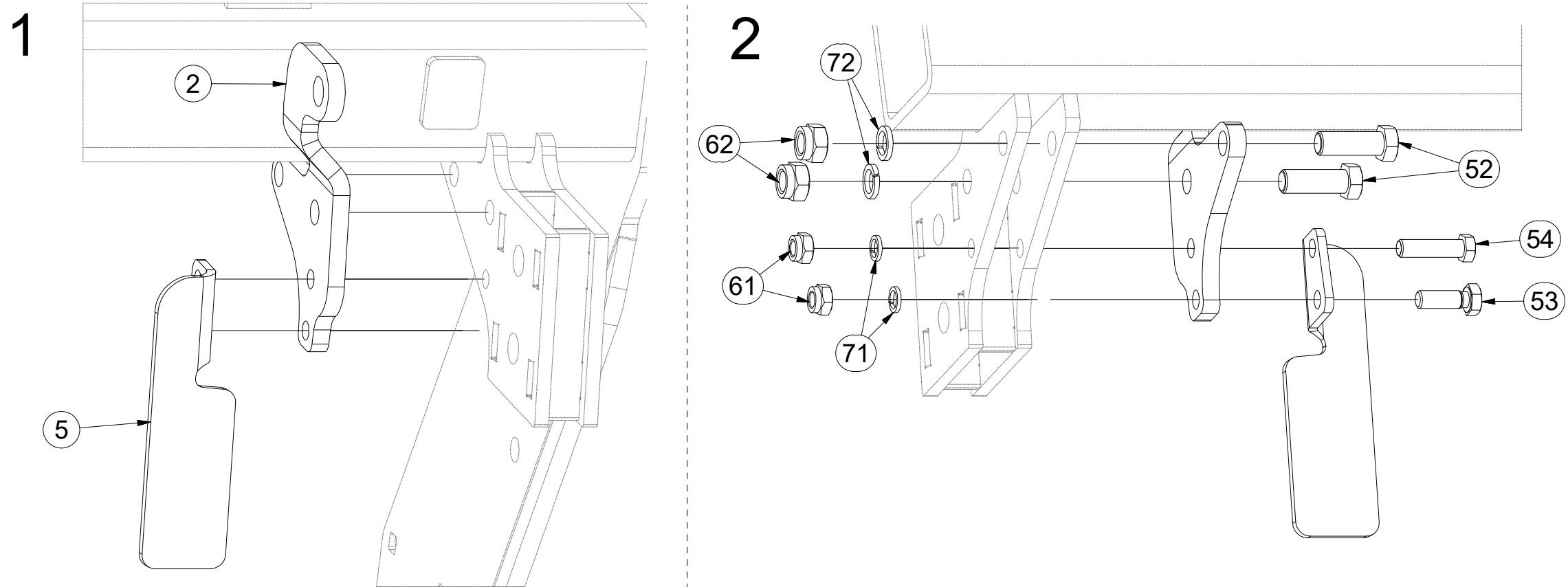
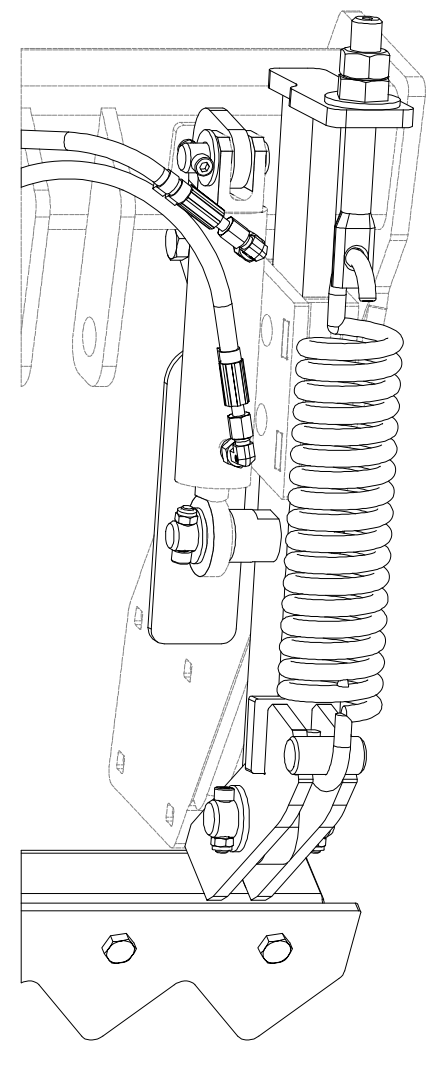

| Pos. | Part Number | Pcs. | Pos. | Part Number | Pcs. |
|------|---------------|------|------|-------------|------|
| 1 | 3008688 | 6 | 56 | m09870 | 12 |
| 2 | 4010387 | 3 | 61 | m04301 | 12 |
| 5 | 4010389 | 3 | 62 | m03683 | 12 |
| 6 | 8000734-90007 | 6 | 63 | m05648 | 6 |
| 7 | 4015710 | 6 | 65 | m04503 | 24 |
| 8 | 4015712 | 6 | 71 | m03988 | 12 |
| 52 | m02254 | 12 | 72 | m02157 | 12 |
| 53 | m04343 | 6 | 73 | m01229 | 6 |
| 54 | m06077 | 6 | 76 | m03768 | 12 |

ⒸZ SADA PŘEDNÍCH SMYKŮ

Ⓓ SATZ VORDERE ACKERSCHLEPPEN

Ⓕ KIT DE NIVELEURS AVANT

3006591

ⒼB SET OF FRONT LEVELLING BARS

ⒺU КОМПЛЕКТ ПЕРЕДНИХ БОРОН

ⒽL ZESTAW PRZEDNICH WŁÓK

Farmet

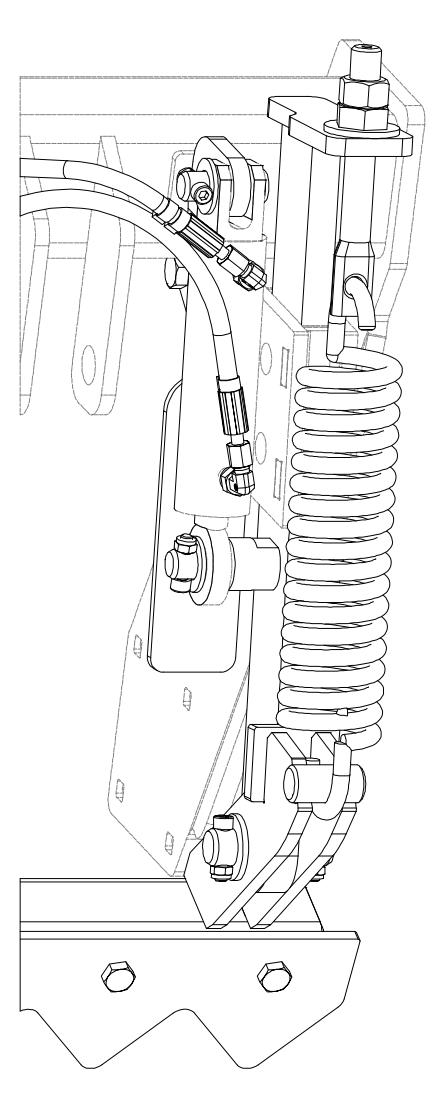

5

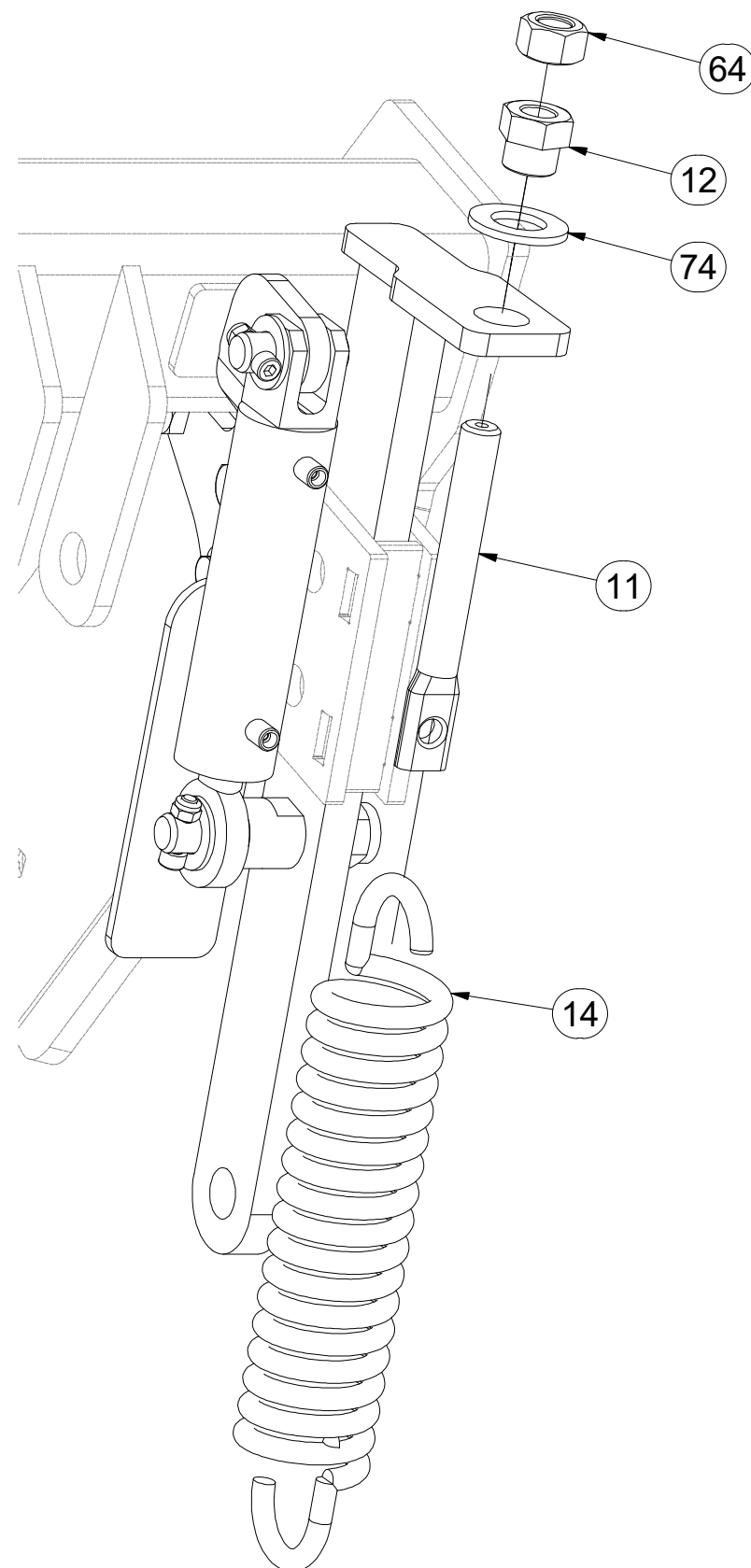

6

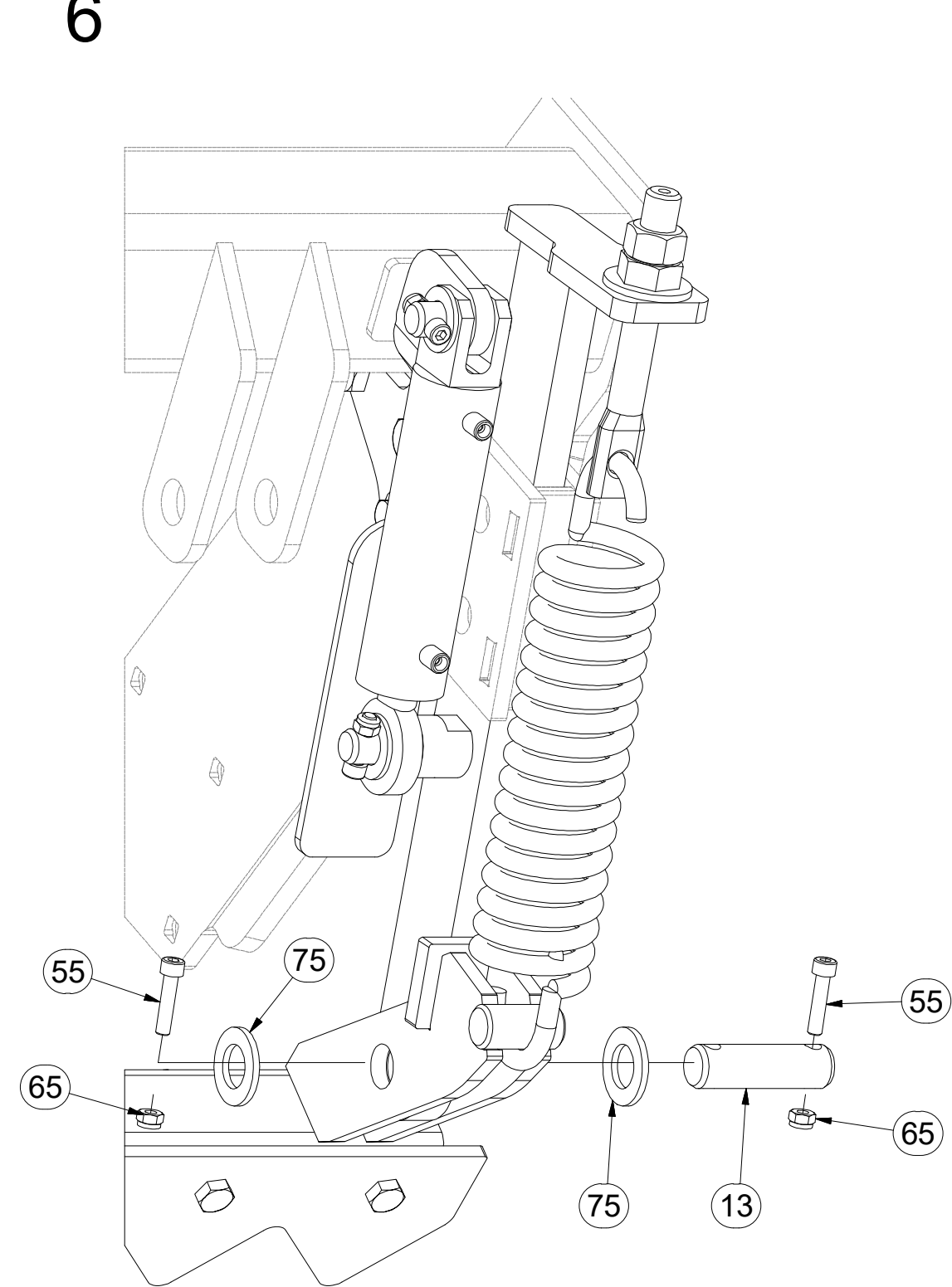

| Pos. | Part Number | Pcs. |
|------|-------------|------|
| 11 | 4003401 | 6 |
| 12 | 4000189 | 6 |
| 13 | 4010390 | 6 |
| 14 | m02597 | 6 |
| 55 | m09464 | 12 |
| 64 | m01307 | 6 |
| 65 | m04503 | 24 |
| 74 | m01225 | 6 |
| 75 | m14028 | 12 |

Ⓒ SADA PŘEDNÍCH SMYKŮ

Ⓓ SATZ VORDERE ACKERSCHLEPPEN

Ⓕ KIT DE NIVELEURS AVANT

Ⓖ SET OF FRONT LEVELLING BARS

Ⓡ КОМПЛЕКТ ПЕРЕДНИХ БОРОН

Ⓟ ZESTAW PRZEDNICH WŁÓK



m16046

| Pos. | Part Number | Pcs. |
|------|-------------|------|
| 3 | m09627 | 4 |
| 6 | m04087 | 2 |
| 10 | m03889 | 2 |
| 14 | m03849 | 2 |
| 15 | m03743 | 2 |

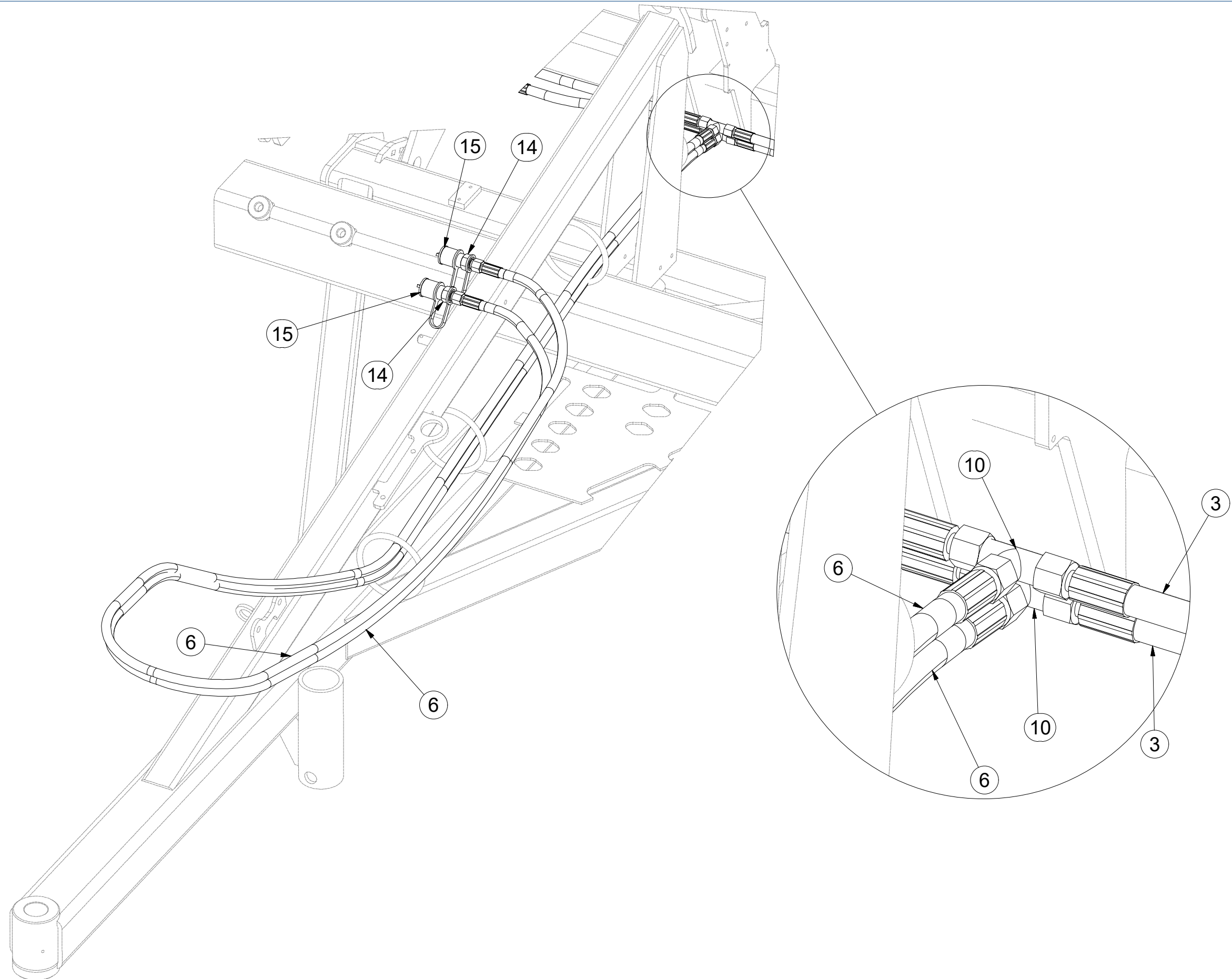
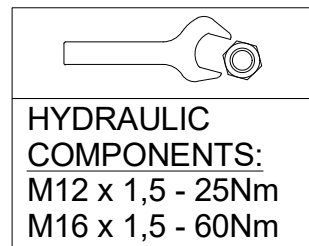

ⒸZ SADA PŘEDNÍCH SMYKŮ

Ⓓ SATZ VORDERE ACKERSCHLEPPEN

Ⓕ KIT DE NIVELEURS AVANT

ⒼB SET OF FRONT LEVELLING BARS

ⒺU КОМПЛЕКТ ПЕРЕДНИХ БОРОН

ⒻL ZESTAW PRZEDNICH WŁÓK



3006591

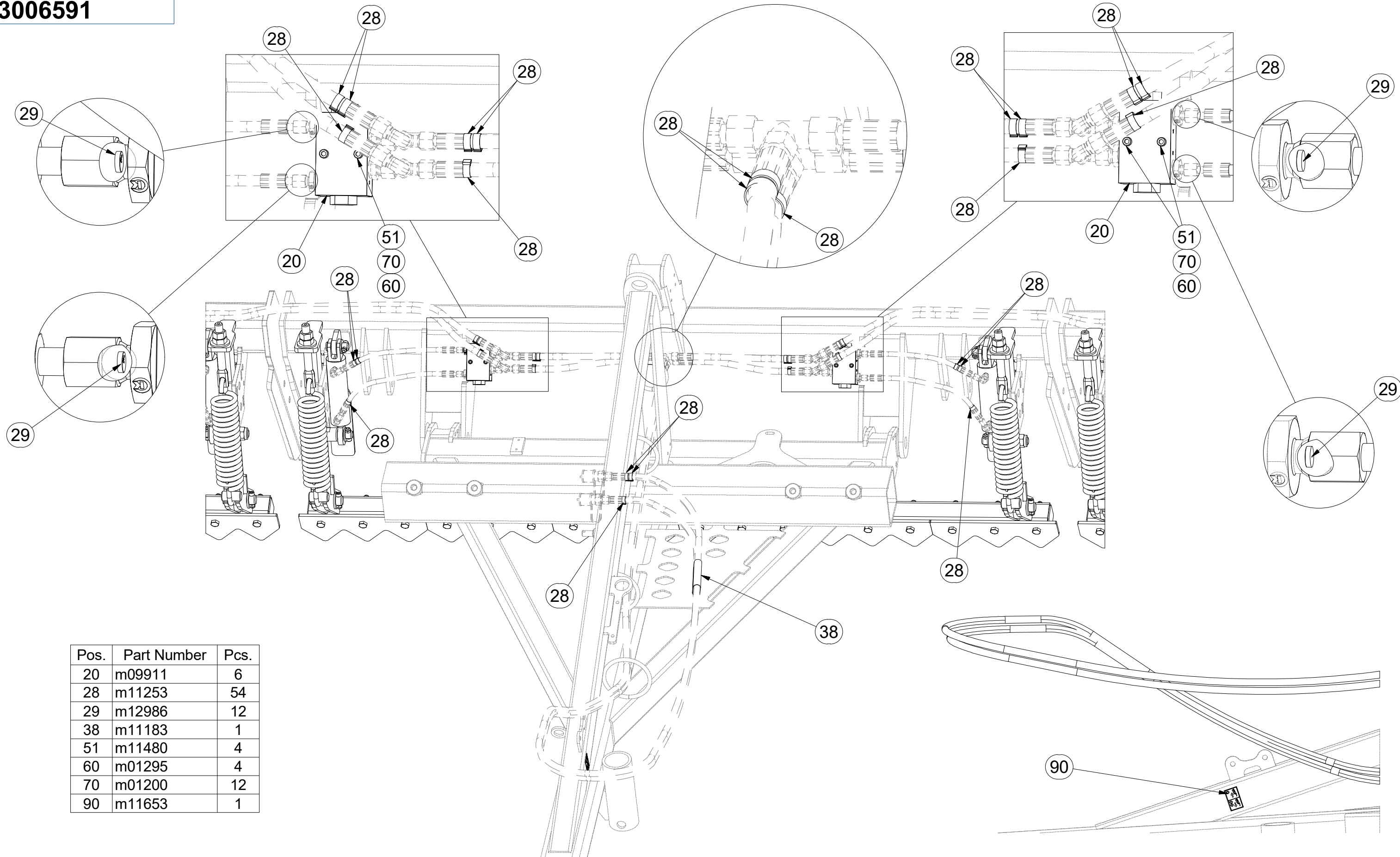

Ⓒ SADA PŘEDNÍCH SMYKŮ

Ⓓ SATZ VORDERE ACKERSCHLEPPEN

Ⓕ KIT DE NIVELEURS AVANT

Ⓖ SET OF FRONT LEVELLING BARS

Ⓡ КОМПЛЕКТ ПЕРЕДНИХ БОРОН

Ⓟ ZESTAW PRZEDNICH WŁÓK



m16046

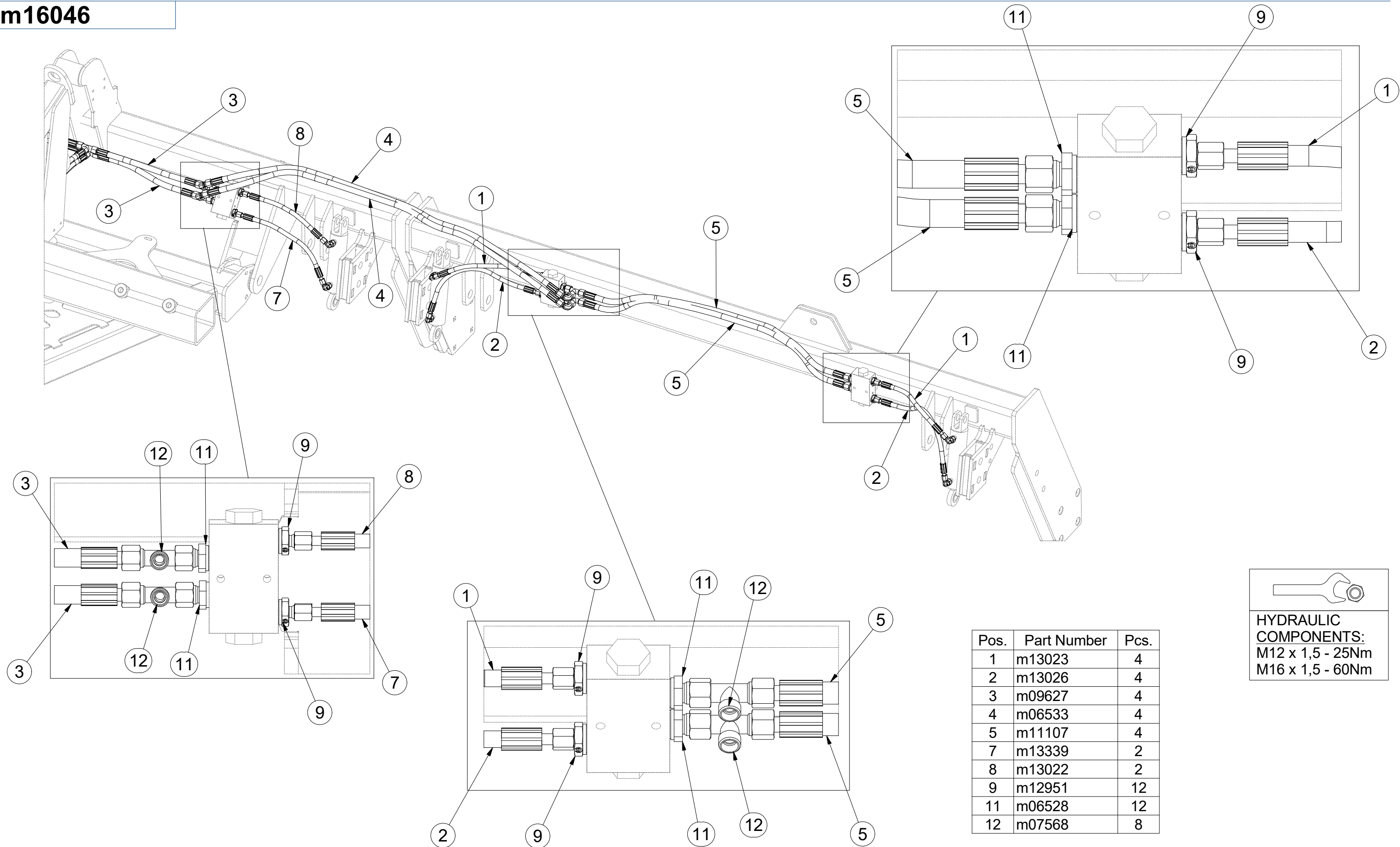

| Pos. | Part Number | Pcs. |
|------|-------------|------|
| 1 | m13023 | 4 |
| 2 | m13026 | 4 |
| 3 | m09627 | 4 |
| 4 | m06533 | 4 |
| 5 | m11107 | 4 |
| 7 | m13339 | 2 |
| 8 | m13022 | 2 |
| 9 | m12951 | 12 |
| 11 | m06528 | 12 |
| 12 | m07568 | 8 |

 HYDRAULIC
 COMPONENTS:
 M12 x 1,5 - 25Nm
 M16 x 1,5 - 60Nm

ⒸZ SADA PŘEDNÍCH SMYKŮ

Ⓓ SATZ VORDERE ACKERSCHLEPPEN

Ⓕ KIT DE NIVELEURS AVANT

ⒼB SET OF FRONT LEVELLING BARS

ⒶU КОМПЛЕКТ ПЕРЕДНИХ БОРОН

ⒶL ZESTAW PRZEDNICH WŁÓK



3006591

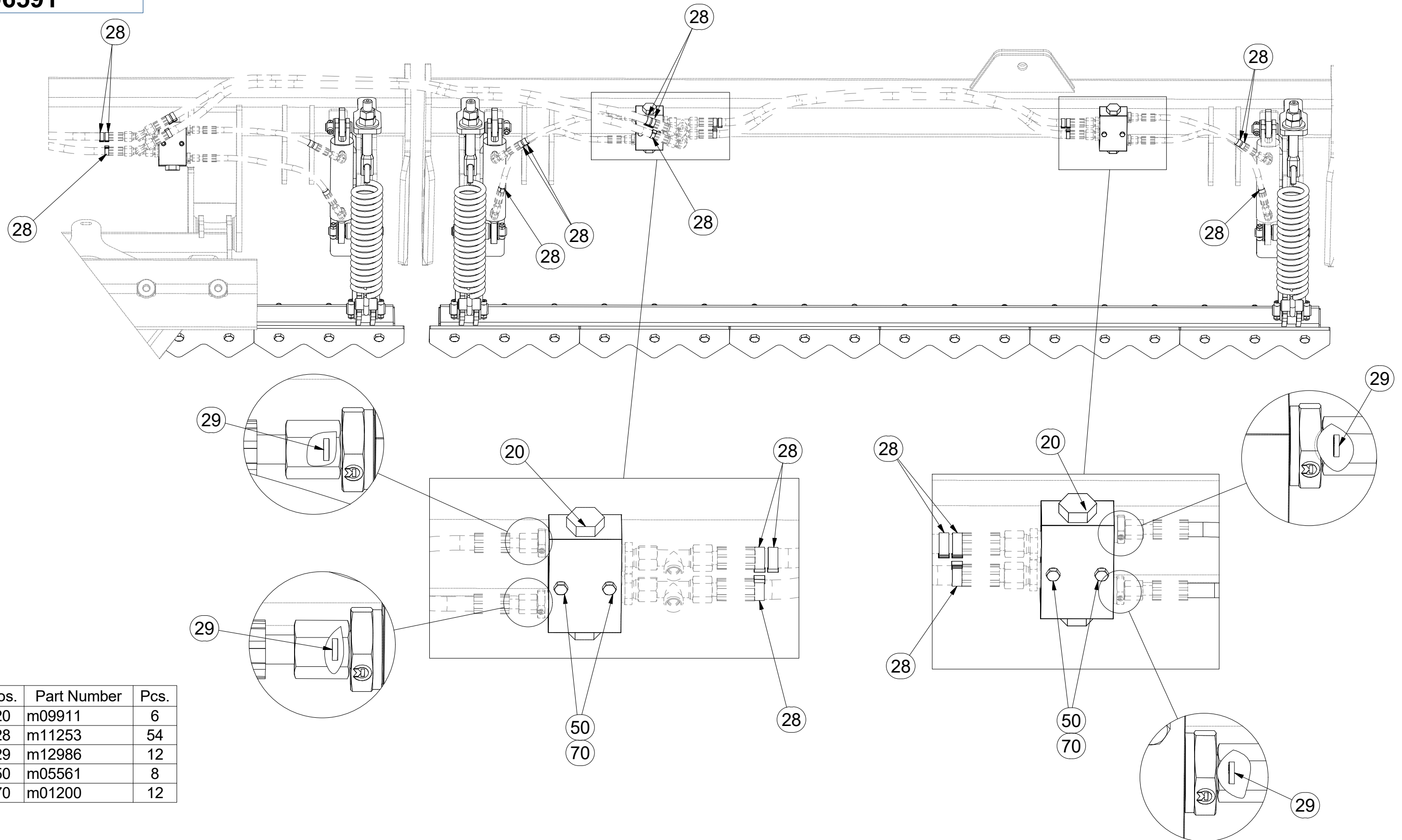

| Pos. | Part Number | Pcs. |
|------|-------------|------|
| 20 | m09911 | 6 |
| 28 | m11253 | 54 |
| 29 | m12986 | 12 |
| 50 | m05561 | 8 |
| 70 | m01200 | 12 |

Ⓒ SADA PŘEDNÍCH SMYKŮ

Ⓓ SATZ VORDERE ACKERSCHLEPPEN

Ⓕ KIT DE NIVELEURS AVANT

Ⓖ SET OF FRONT LEVELLING BARS

Ⓡ КОМПЛЕКТ ПЕРЕДНИХ БОРОН

Ⓟ ZESTAW PRZEDNICH WŁÓK



m16046

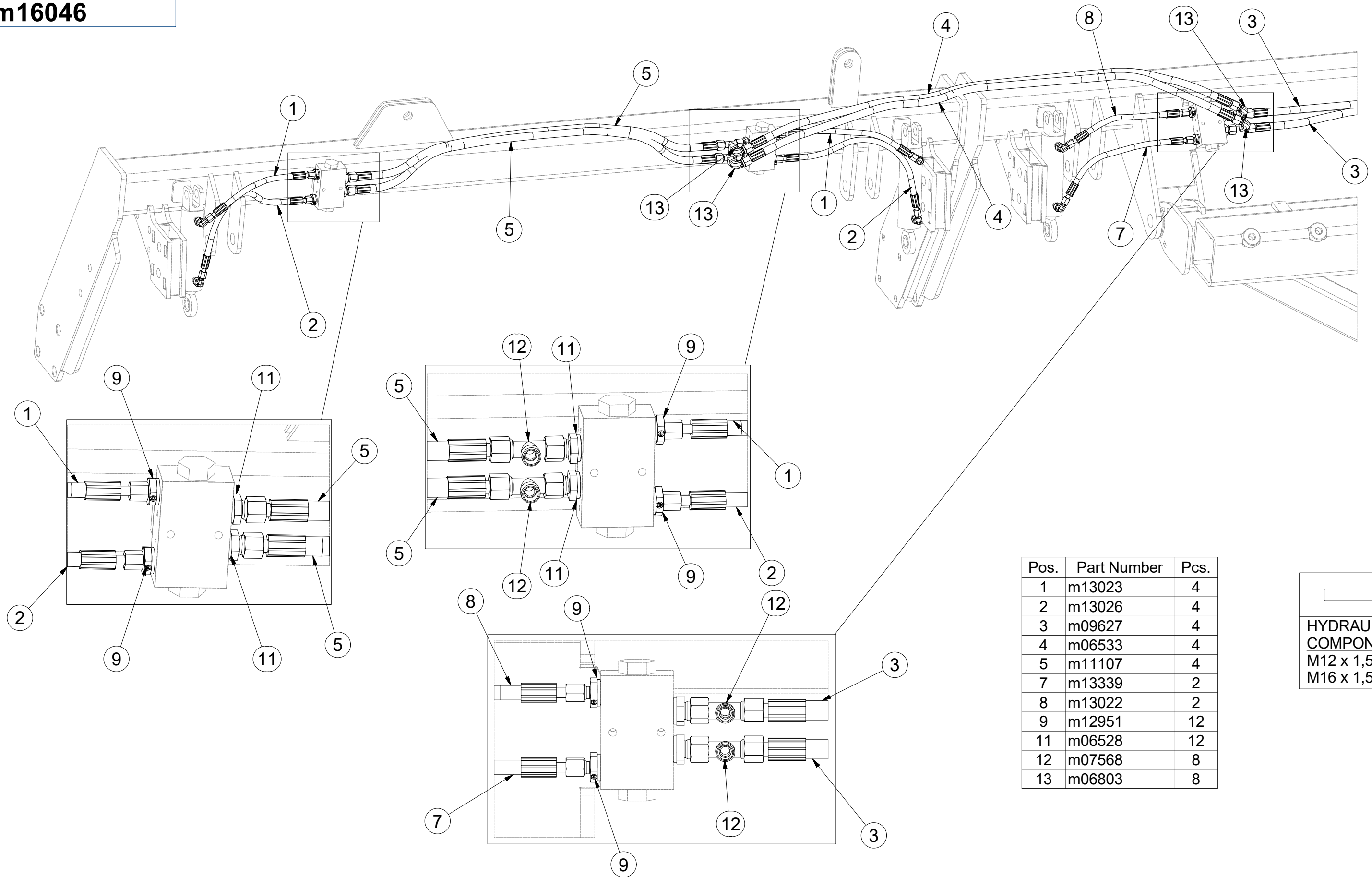

| Pos. | Part Number | Pcs. |
|------|-------------|------|
| 1 | m13023 | 4 |
| 2 | m13026 | 4 |
| 3 | m09627 | 4 |
| 4 | m06533 | 4 |
| 5 | m11107 | 4 |
| 7 | m13339 | 2 |
| 8 | m13022 | 2 |
| 9 | m12951 | 12 |
| 11 | m06528 | 12 |
| 12 | m07568 | 8 |
| 13 | m06803 | 8 |

HYDRAULIC COMPONENTS:
M12 x 1,5 - 25Nm
M16 x 1,5 - 60Nm

ⒸZ SADA PŘEDNÍCH SMYKŮ

Ⓓ SATZ VORDERE ACKERSCHLEPPEN

Ⓕ KIT DE NIVELEURS AVANT

ⒼB SET OF FRONT LEVELLING BARS

ⒺU КОМПЛЕКТ ПЕРЕДНИХ БОРОН

ⒻL ZESTAW PRZEDNICH WŁÓK



3006591

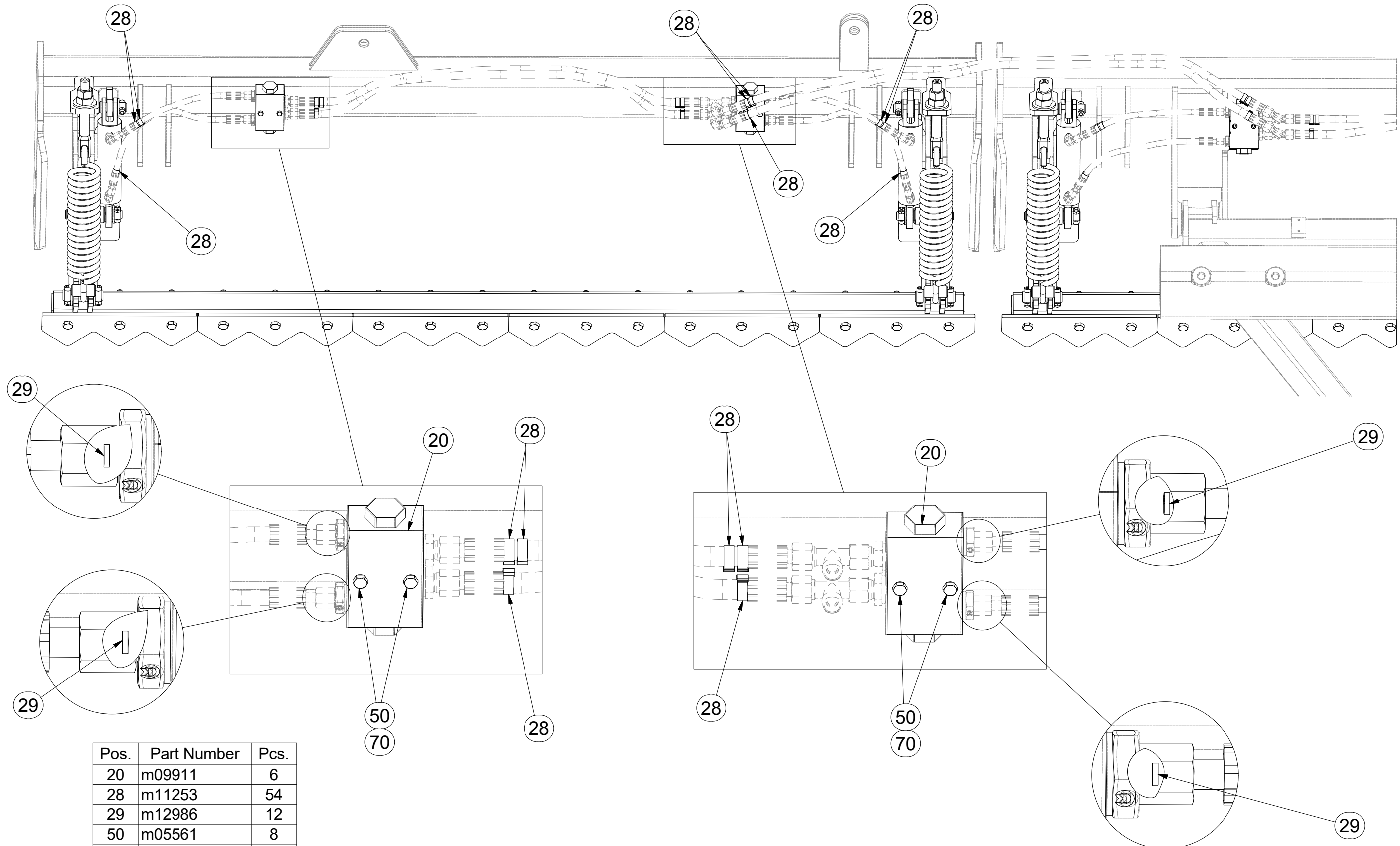

| Pos. | Part Number | Pcs. |
|------|-------------|------|
| 20 | m09911 | 6 |
| 28 | m11253 | 54 |
| 29 | m12986 | 12 |
| 50 | m05561 | 8 |
| 70 | m01200 | 12 |

Ⓒ PŘEDNÍ SMYK

Ⓓ VORDERE ACKERSCHLEIFE

Ⓕ NIVELEUR AVANT

Ⓖ FRONT DRAG

Ⓡ ПЕРЕДНЯЯ БОРОНА

Ⓟ PRZEDNIA WŁÓKA

Farmet

3010749

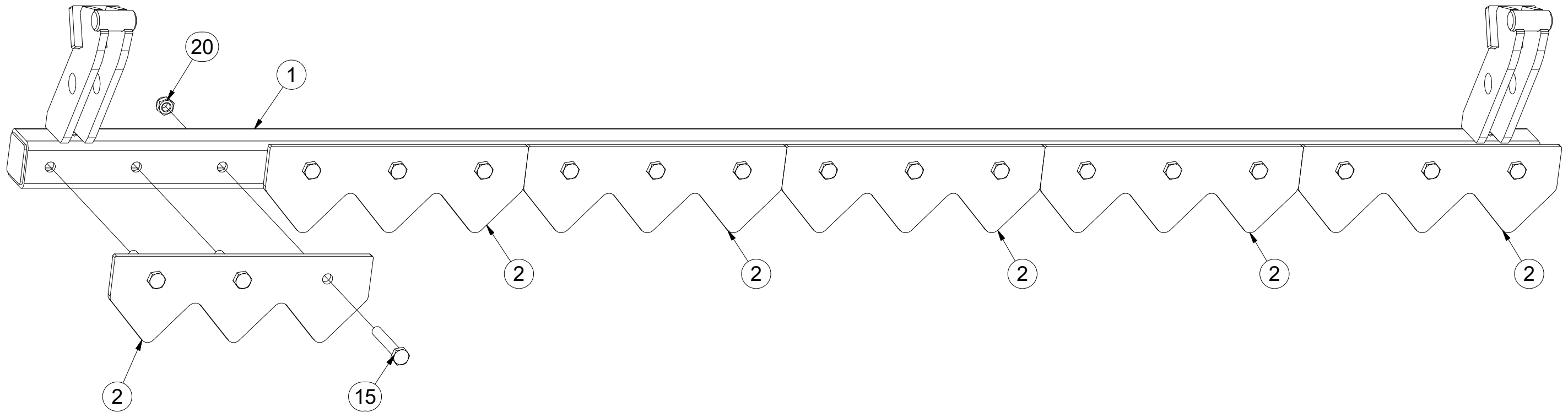

| Pos. | Part Number | Pcs. |
|------|-------------|------|
| 1 | 3010748 | 1 |
| 2 | 4021741 | 6 |
| 15 | m09437 | 18 |
| 20 | m04301 | 18 |

ⒸZ SADA PŘEDNÍCH VÁLCŮ

Ⓓ SATZ VORDERE WALZEN

Ⓕ KIT DE ROULEAUX AVANT

3011854

ⒸB SET OF FRONT ROLLERS

ⒸR КОМПЛЕКТ ПЕРЕДНИХ КАТКОВ

ⒸL ZESTAW PRZEDNICH WAŁÓW

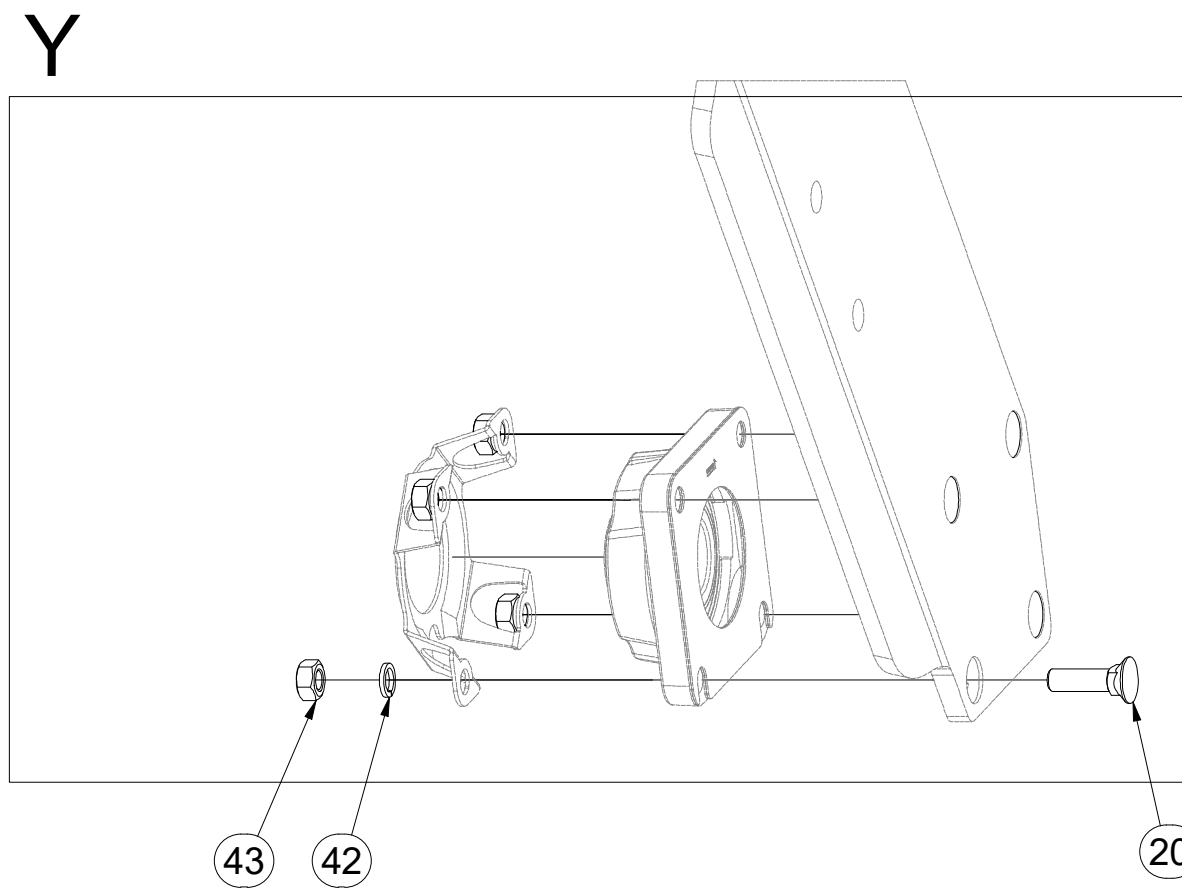
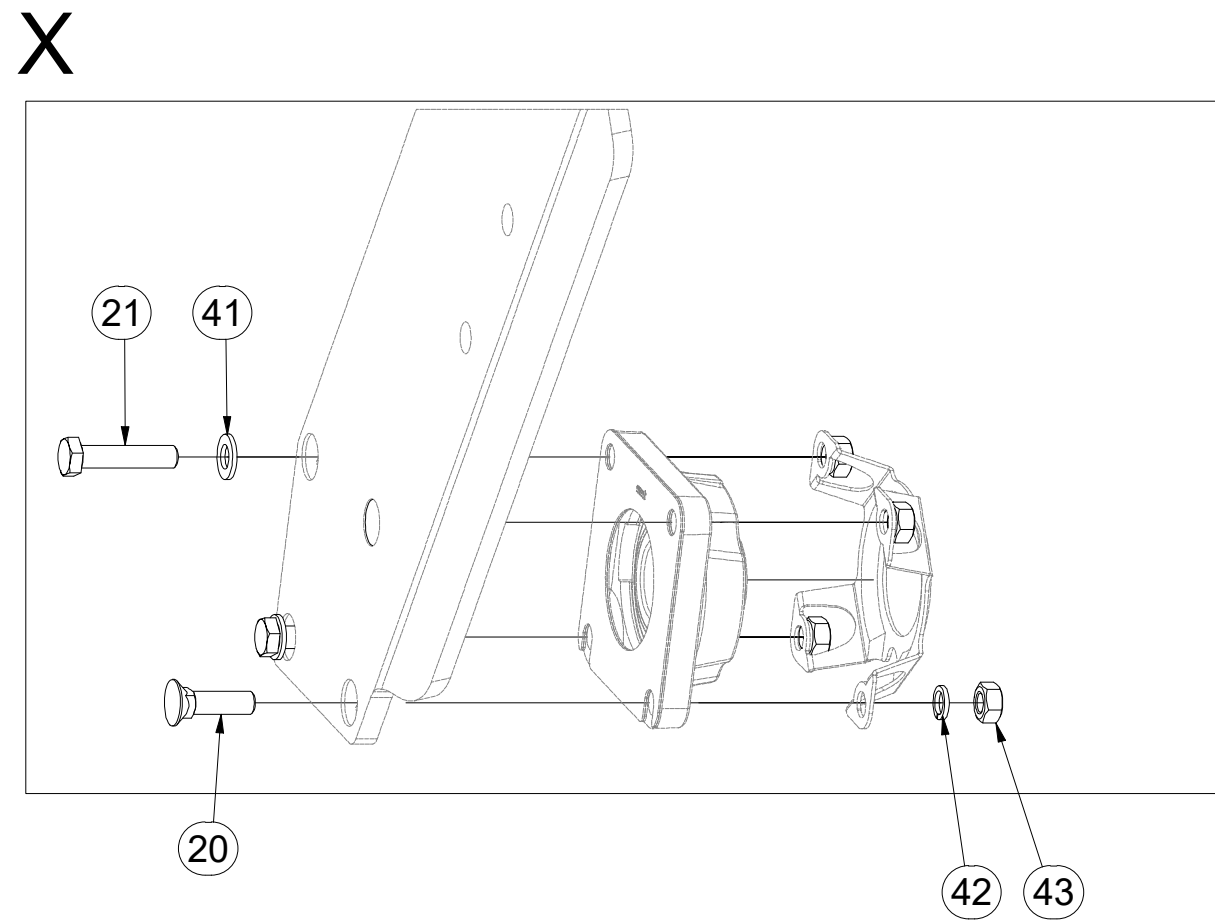
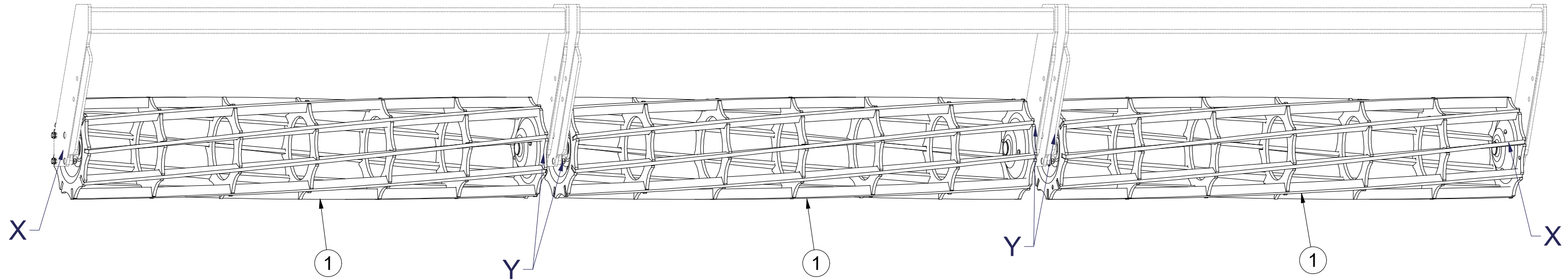

| Pos. | Part Number | Pcs. |
|------|-------------|------|
| 1 | 2000679 | 3 |
| 20 | m03519 | 20 |
| 21 | m04412 | 4 |
| 41 | m17741 | 4 |
| 42 | m03988 | 24 |
| 43 | m01305 | 24 |

CZ SADA LOŽISEK
 D LAGERSATZ
 F KIT DE ROULEMENTS

GB SET OF BEARINGS
 RU КОМПЛЕКТ ПОДШИПНИКОВ
 PL ZESTAW ŁOŻYSK



3011890

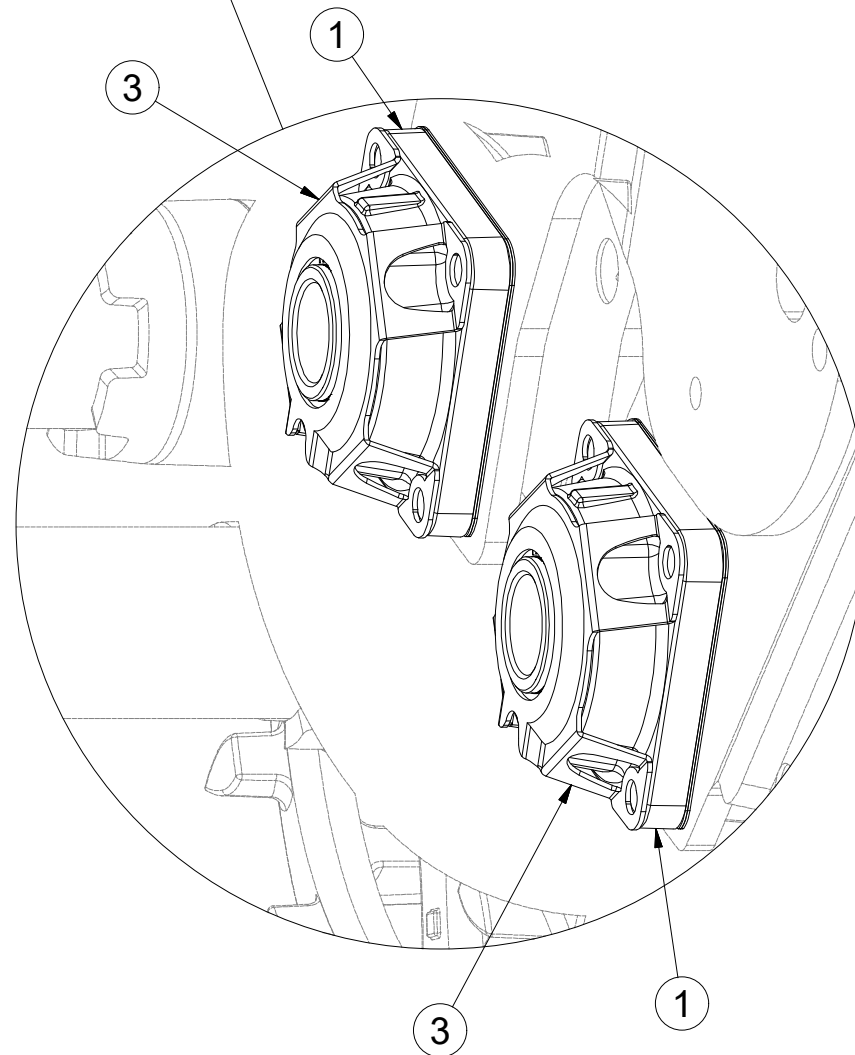
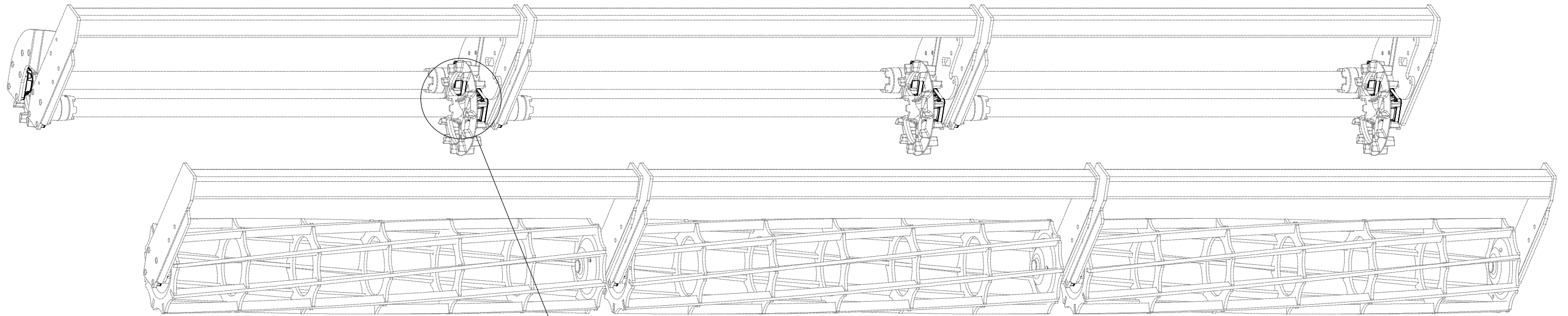

| Pos. | Part Number | Pcs. |
|------|-------------|------|
| 1 | m17341 | 18 |
| 3 | 4024047 | 18 |

CZ SADA LOŽISEK
 D LAGERSATZ
 F KIT DE ROULEMENTS

GB SET OF BEARINGS
 RU КОМПЛЕКТ ПОДШИПНИКОВ
 PL ZESTAW ŁOŻYSK



3011890

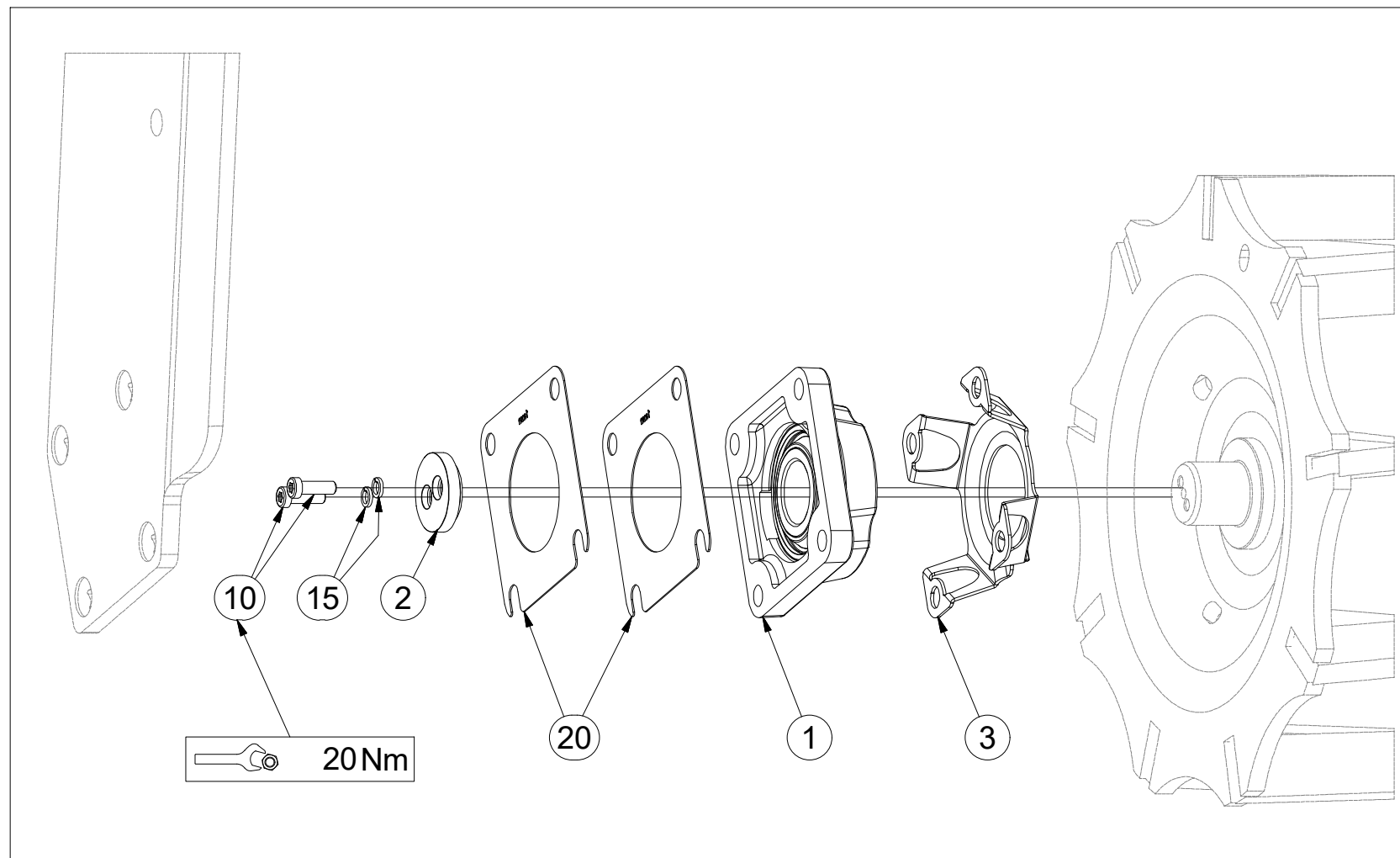
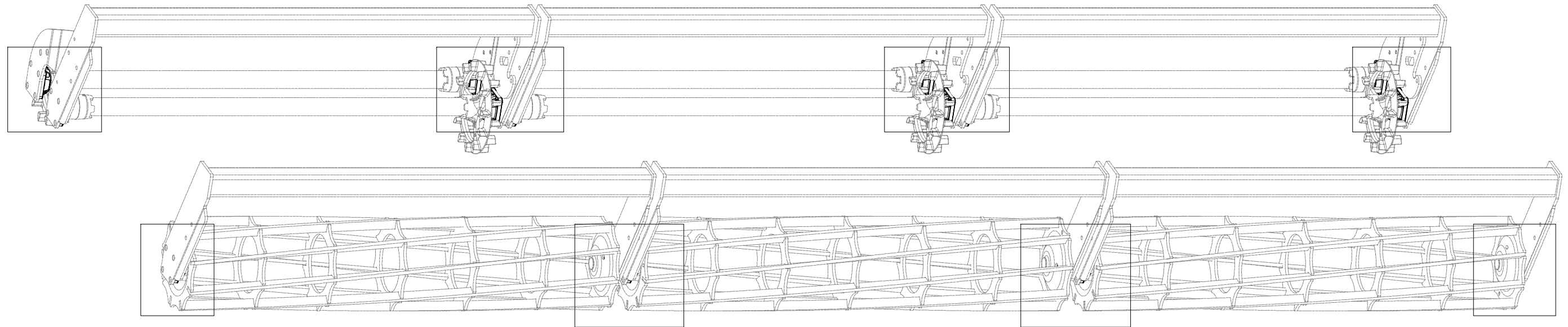

| Pos. | Part Number | Pcs. |
|------|-------------|------|
| 1 | m17341 | 18 |
| 2 | 4024753 | 18 |
| 3 | 4024047 | 18 |
| 10 | m18858 | 36 |
| 15 | m01202 | 36 |
| 20 | 4016809 | 36 |

(CZ) SADA OVLÁDÁNÍ RADLIC
 (D) STEUERSATZ PFLUGSCHAREN
 (F) KIT DE COMMANDE DES SOCS

(GB) SET OF PLOUGHSHARE CONTROL
 (RU) КОМПЛЕКТ УПРАВЛЕНИЯ ЛАП
 (PL) ZESTAW STEROWANIA RADLICAMI



3011967

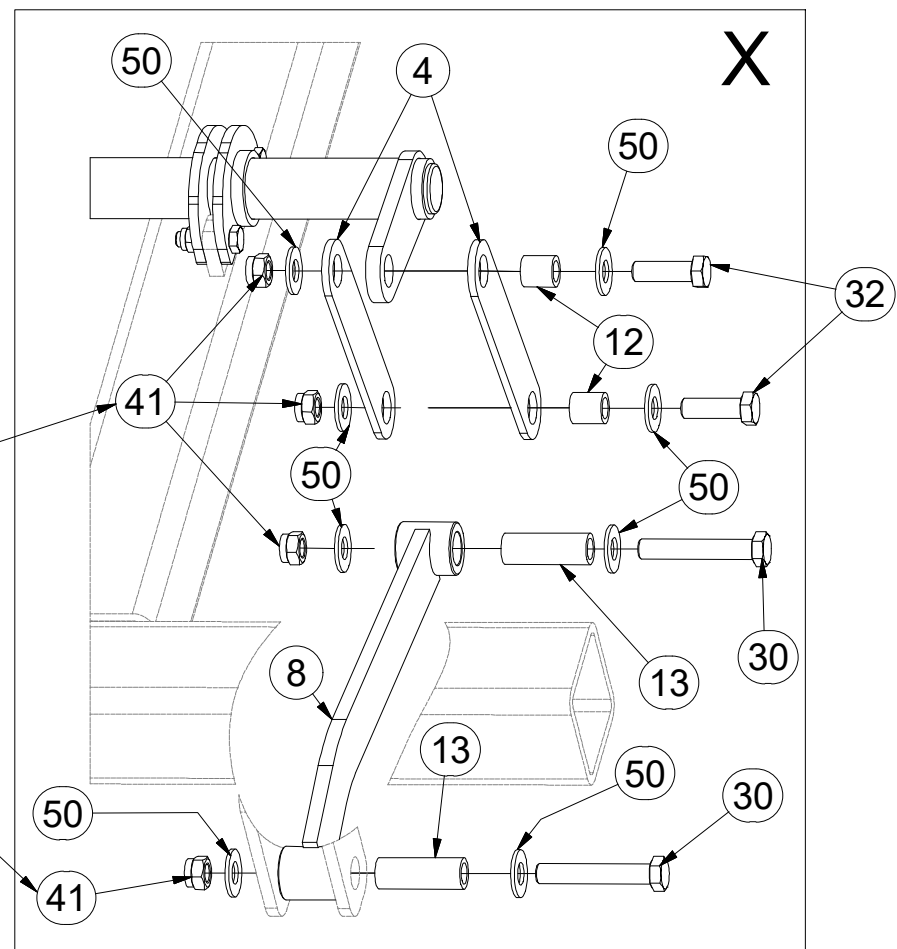
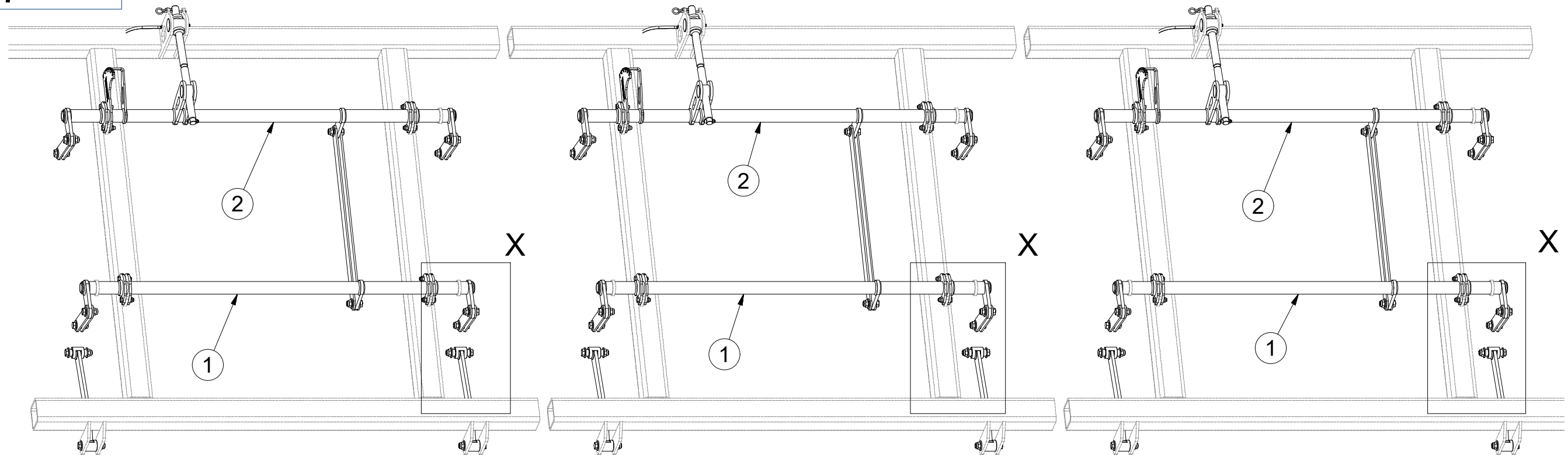

| Pos. | Part Number | Pcs. | Pos. | Part Number | Pcs. |
|------|---------------|------|------|-------------|------|
| 1 | 3002830 | 3 | 13 | 9001426 | 12 |
| 2 | 3002831 | 3 | 30 | m07673 | 12 |
| 4 | 4005333 | 24 | 32 | m04355 | 30 |
| 8 | 8000990-30007 | 6 | 41 | m03683 | 42 |
| 12 | 4002265 | 30 | 50 | m05651 | 84 |

Ⓒ CZ SADA OVLÁDÁNÍ RADLIC

Ⓓ STEUERSATZ PFLUGSCHAREN

Ⓕ KIT DE COMMANDE DES SOCS

Ⓖ GB SET OF PLOUGHSHARE CONTROL

Ⓡ RU КОМПЛЕКТ УПРАВЛЕНИЯ ЛАП

Ⓟ PL ZESTAW STEROWANIA RADLICAMI



3011967

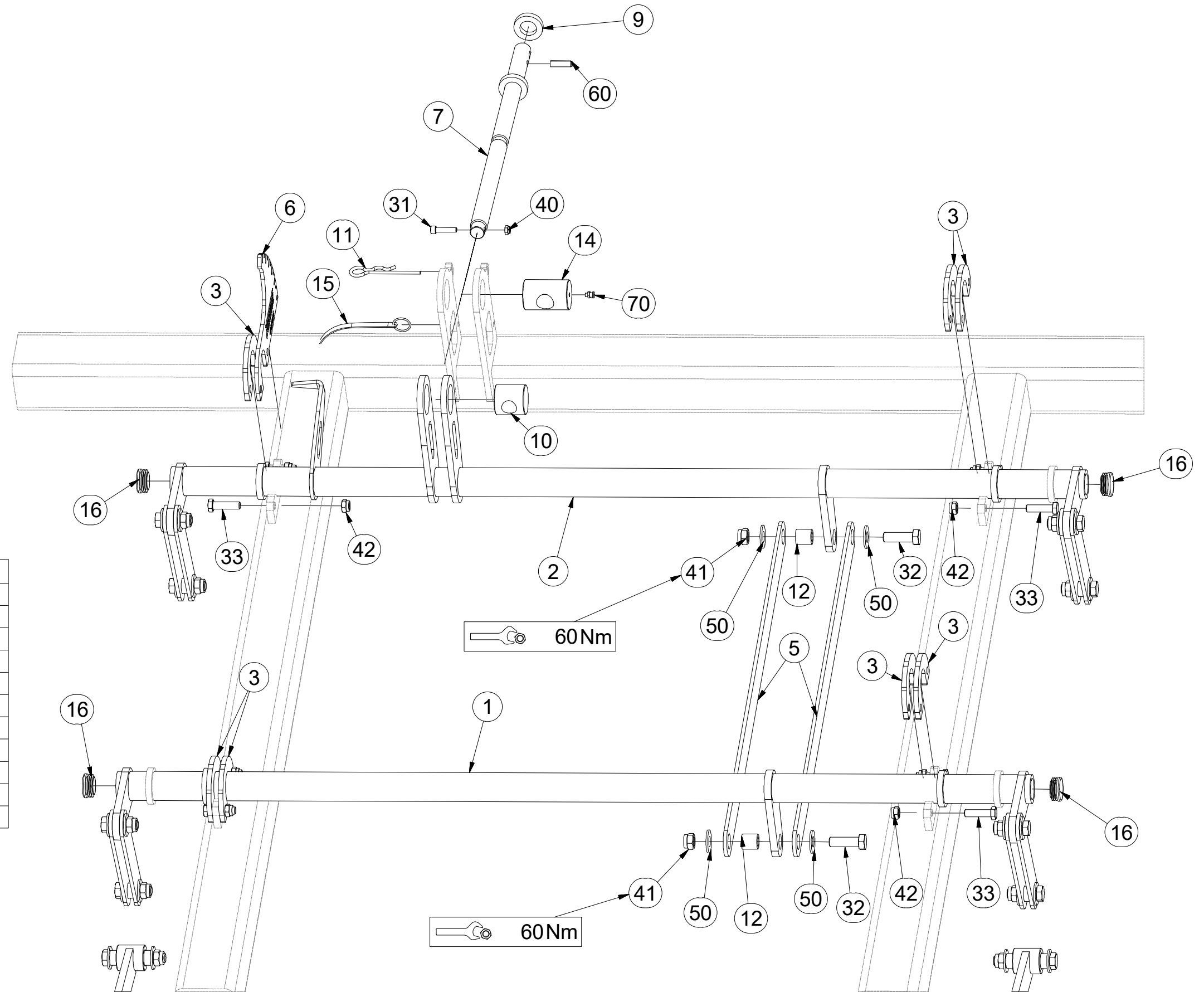
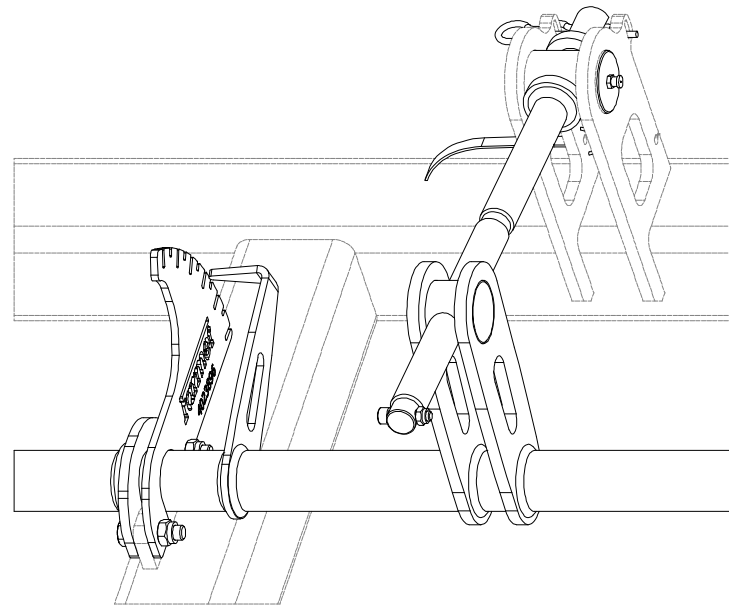

| Pos. | Part Number | Pcs. | Pos. | Part Number | Pcs. |
|------|-------------|------|------|-------------|------|
| 1 | 3002830 | 3 | 15 | m12467 | 3 |
| 2 | 3002831 | 3 | 16 | m10130 | 12 |
| 3 | 4005332 | 21 | 31 | m09464 | 3 |
| 5 | 4005334 | 6 | 32 | m04355 | 30 |
| 6 | 4023896 | 3 | 33 | m06077 | 24 |
| 7 | 4024250 | 3 | 40 | m04503 | 3 |
| 9 | 9002560 | 3 | 41 | m03683 | 42 |
| 10 | 4005340 | 3 | 42 | m04301 | 24 |
| 11 | m09988 | 3 | 50 | m05651 | 84 |
| 12 | 4002265 | 30 | 60 | m10736 | 3 |
| 14 | 9002114 | 3 | 70 | m10451 | 3 |

Ⓒ SADA RADLIC

Ⓓ SCHARSATZ

Ⓕ KIT DE SOCS

Ⓒ SET OF PLOUGHSHARES

Ⓓ КОМПЛЕКТ ЛАП

Ⓕ ZESTAW REDLIC



3012374

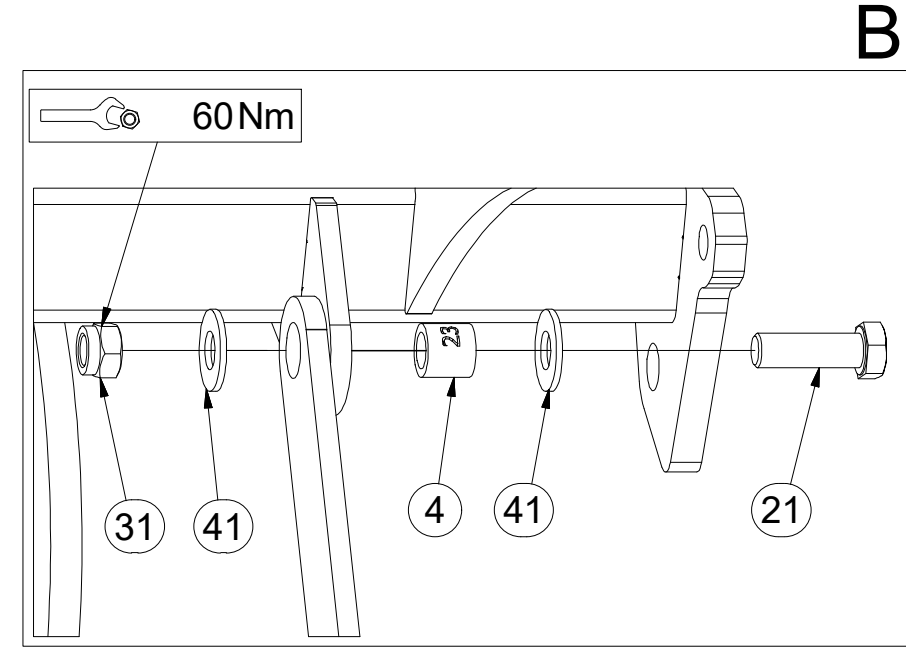
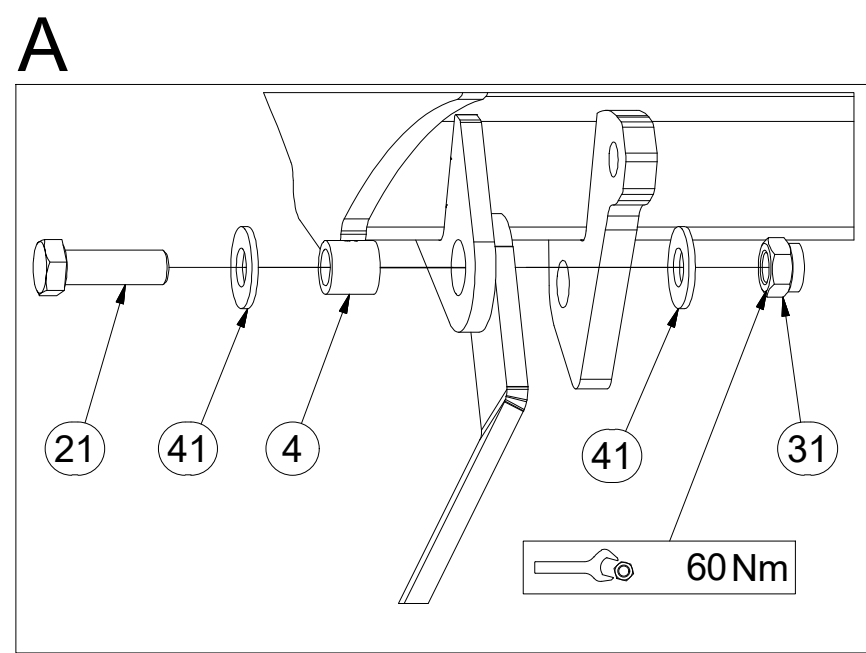
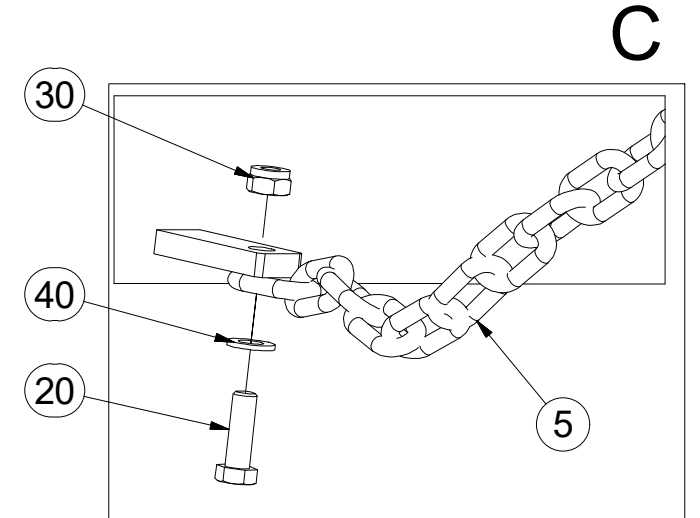
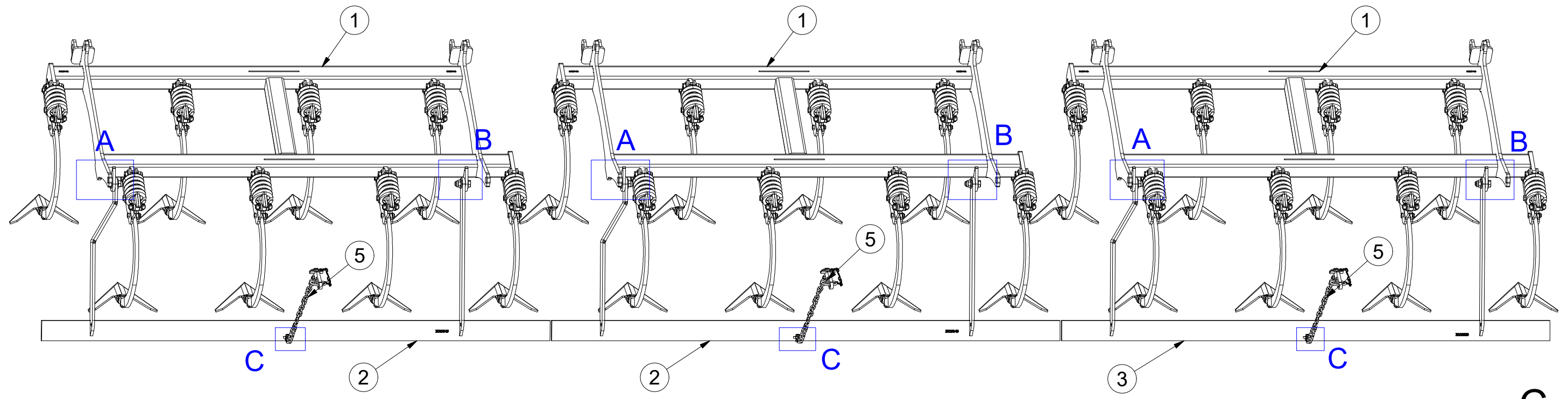

| Pos. | Part Number | Pcs. |
|------|-------------|------|
| 1 | 3012387 | 3 |
| 2 | 3009549 | 2 |
| 3 | 3009550 | 1 |
| 4 | 4022223 | 6 |
| 5 | 4001641 | 3 |
| 20 | m01092 | 3 |
| 21 | m04355 | 6 |
| 30 | m04503 | 3 |
| 31 | m03683 | 6 |
| 40 | m01203 | 3 |
| 41 | m05651 | 12 |

ⒸZ SADA RADLIC

Ⓓ SCHARSATZ

Ⓕ KIT DE SOCS

ⒼB SET OF PLOUGHSHARES

ⒺU КОМПЛЕКТ ЛАП

ⒻL ZESTAW REDLIC



3012387

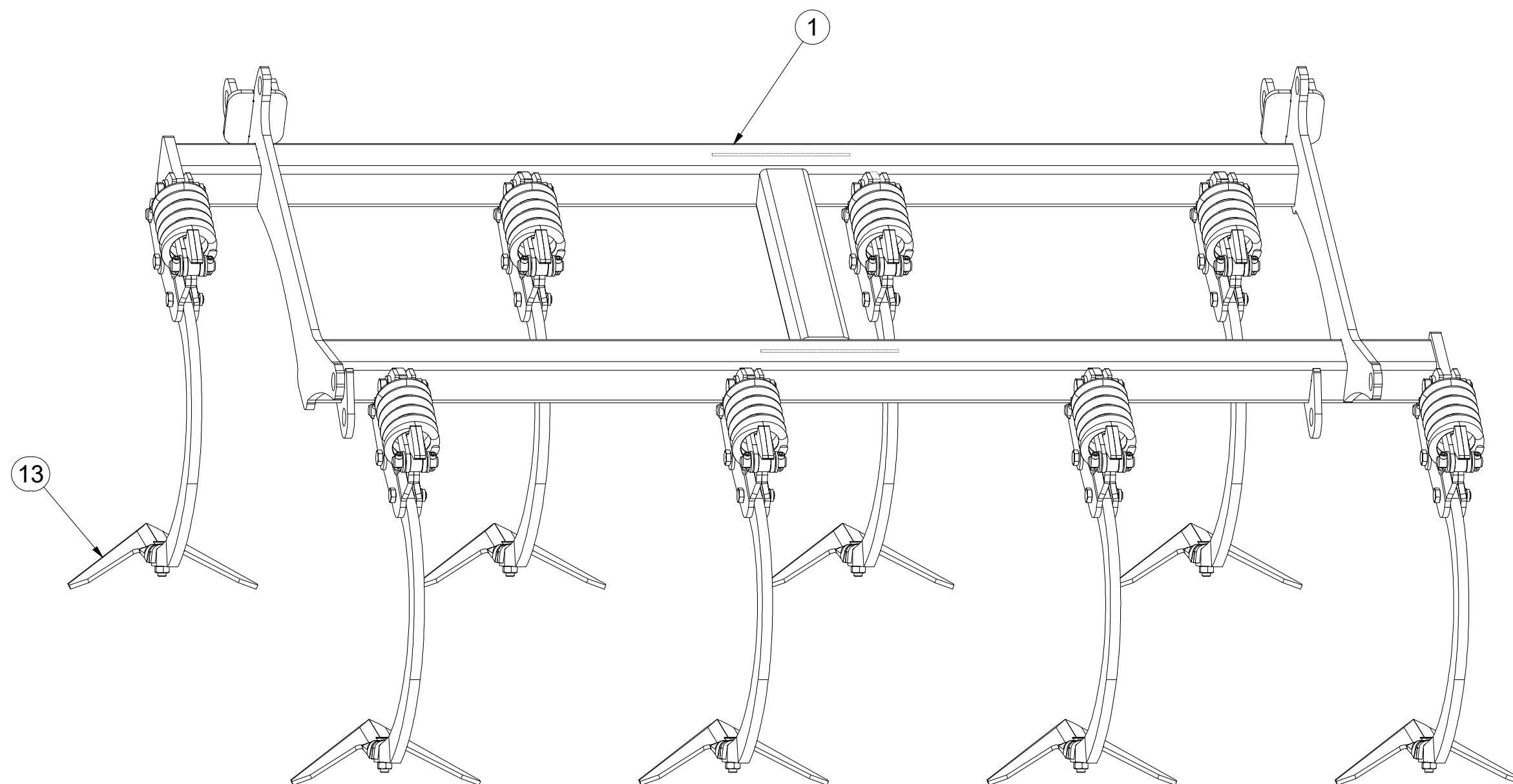

| Pos. | Part Number | Pcs. |
|------|-------------|------|
| 1 | 3012388 | 1 |
| 13 | 3000236-KOO | 8 |

☉ SADA RADLIC

☐ SCHARSATZ

☐ KIT DE SOCS

☉ SET OF PLOUGHSHARES

☐ КОМПЛЕКТ ЛАП

☐ ZESTAW REDLIC



3012387

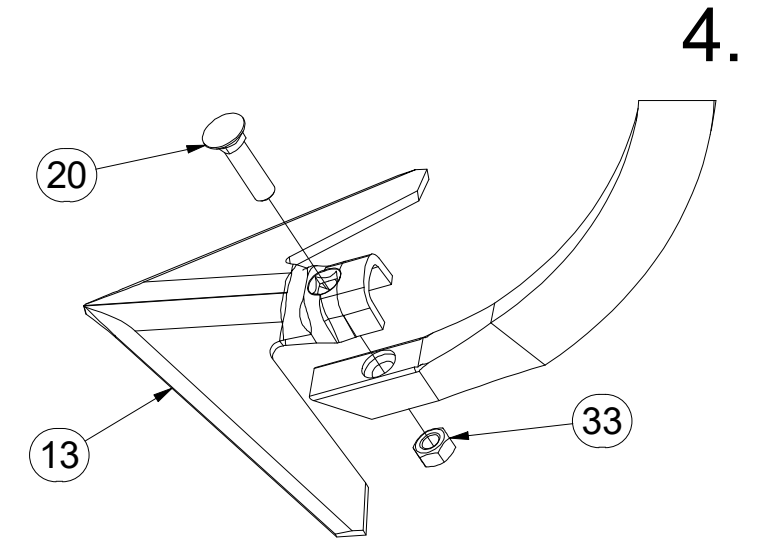
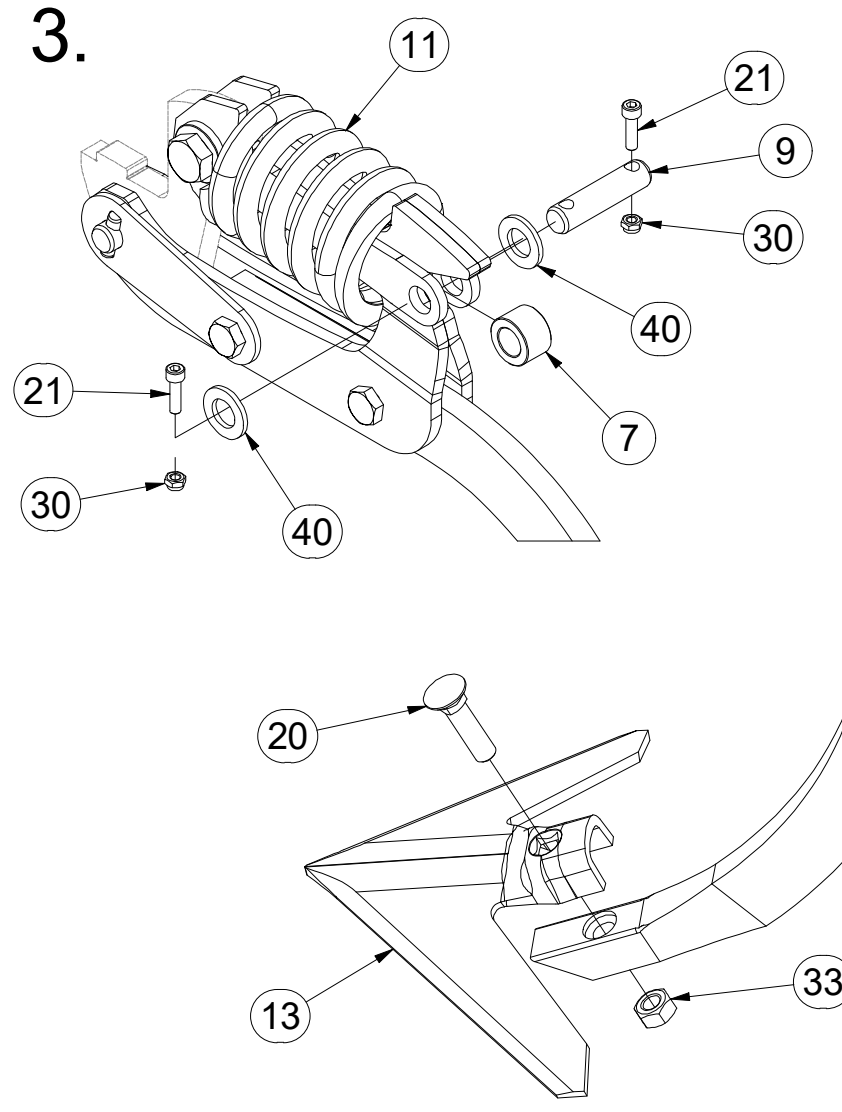
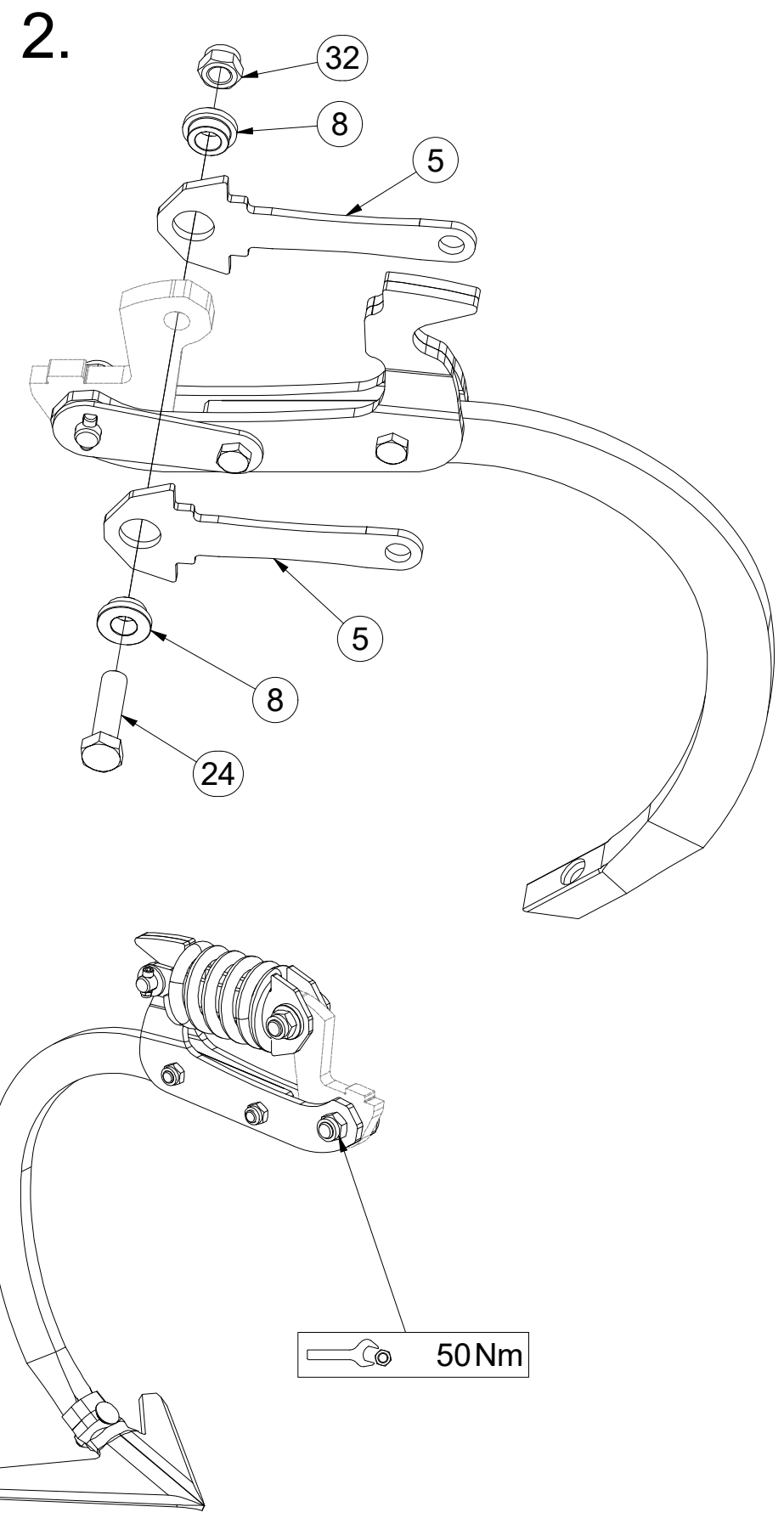
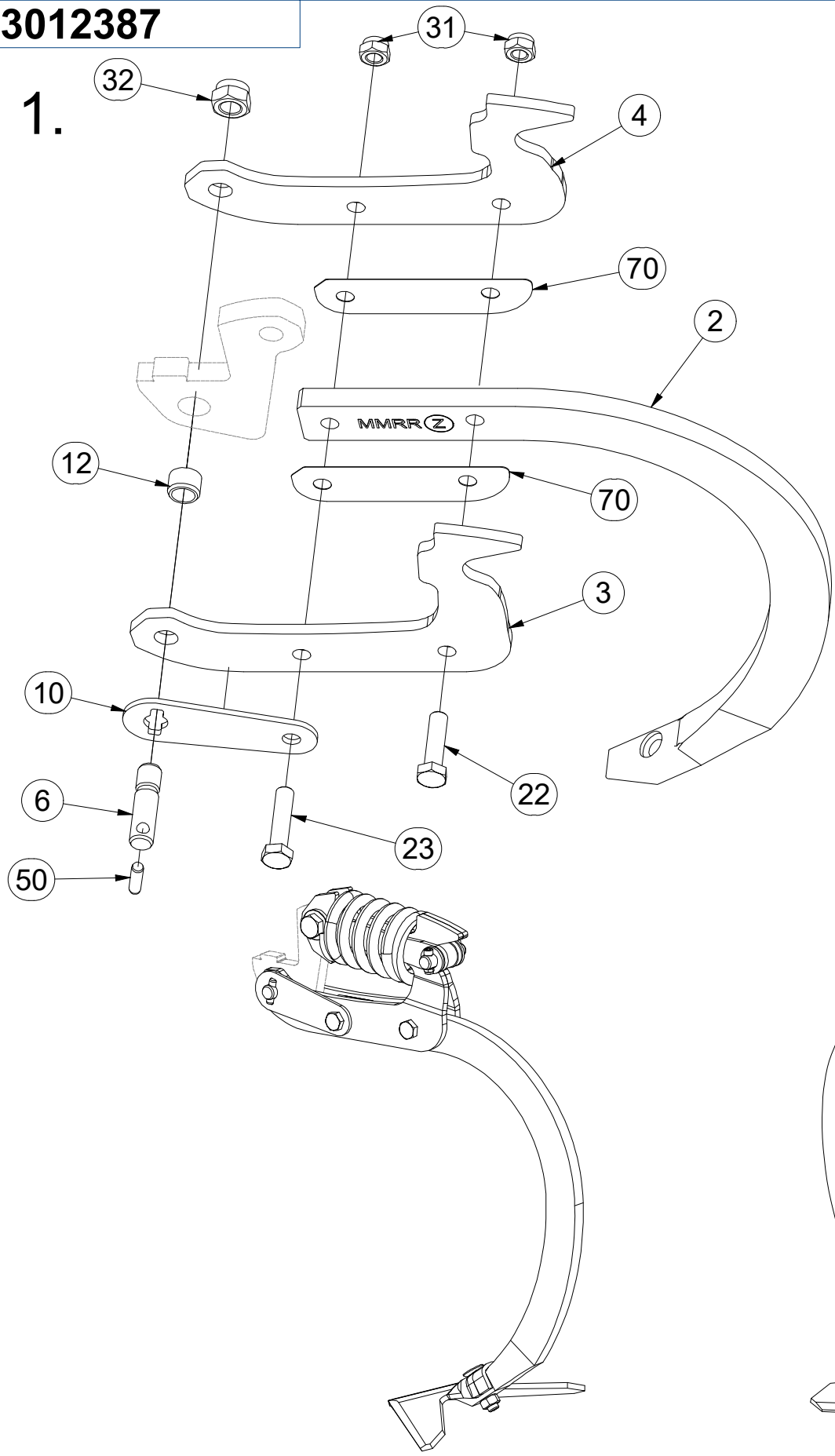

| Pos. | Part Number | Pcs. | Pos. | Part Number | Pcs. |
|------|-------------|------|------|-------------|------|
| 2 | 9005683 | 8 | 20 | m10440 | 8 |
| 3 | 3012358 | 8 | 21 | m15215 | 16 |
| 4 | 3012359 | 8 | 22 | m06077 | 8 |
| 5 | 4024906 | 16 | 23 | m03339 | 8 |
| 6 | 4024918 | 8 | 24 | m14482 | 8 |
| 7 | 4009624 | 8 | 30 | m05560 | 16 |
| 8 | 4014252 | 16 | 31 | m04301 | 16 |
| 9 | 4015783 | 8 | 32 | m03683 | 16 |
| 10 | VZ00003688 | 8 | 33 | m10439 | 8 |
| 11 | m18880 | 8 | 40 | m14971 | 16 |
| 12 | m18882 | 8 | 50 | m18826 | 8 |
| 13 | 3000236-KOO | 8 | 70 | 4014863 | 16 |

- ⒸZ SADA ZADNÍCH VÁLČŮ
- Ⓓ SATZ HINTERE WALZEN
- Ⓕ KIT DE ROULEAUX ARRIÈRE

- ⒼB SET OF REAR ROLLERS
- ⒿU КОМПЛЕКТ ЗАДНИХ КАТКОВ
- ⓅL ZESTAW TYLNYCH WAŁÓW



3011862

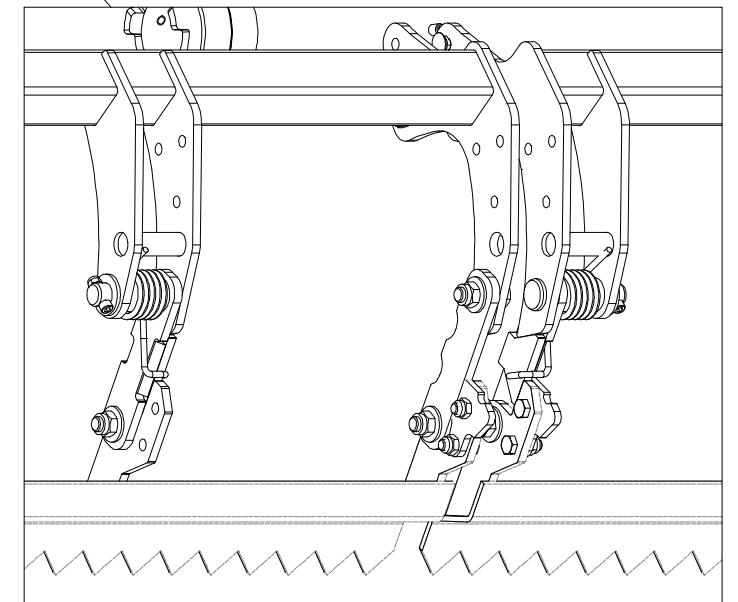
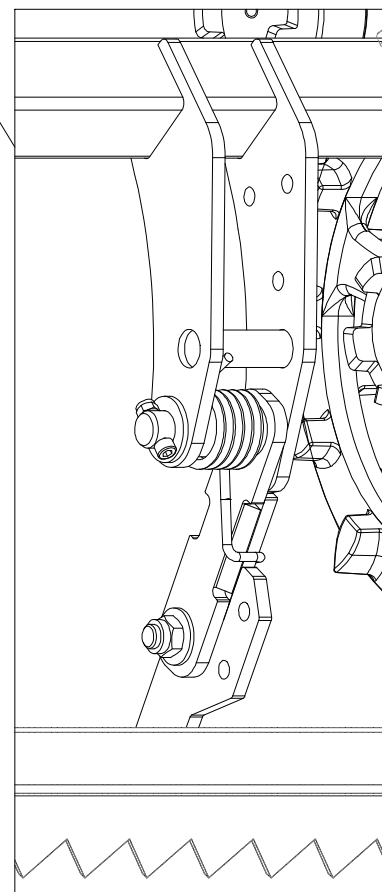
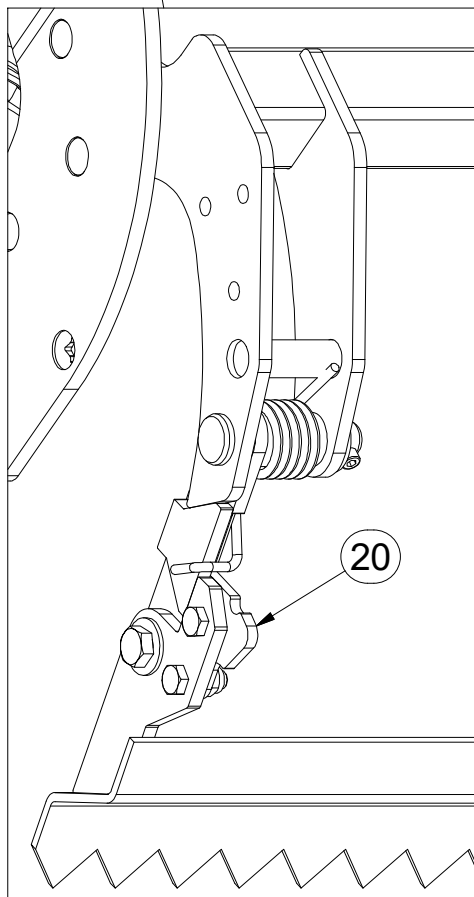
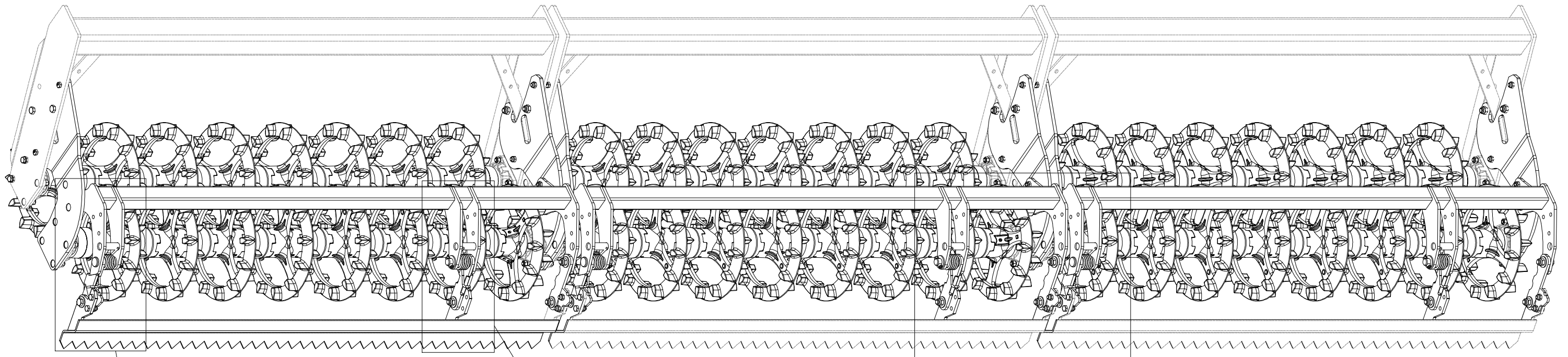

| Pos. | Part Number | Pcs. |
|------|-------------|------|
| 20 | 3006133 | 1 |

CZ SADA ZADNÍCH VÁLČŮ
 D SATZ HINTERE WALZEN
 F KIT DE ROULEAUX ARRIÈRE

GB SET OF REAR ROLLERS
 RU КОМПЛЕКТ ЗАДНИХ КАТКОВ
 PL ZESTAW TYLNYCH WAŁÓW



3011862

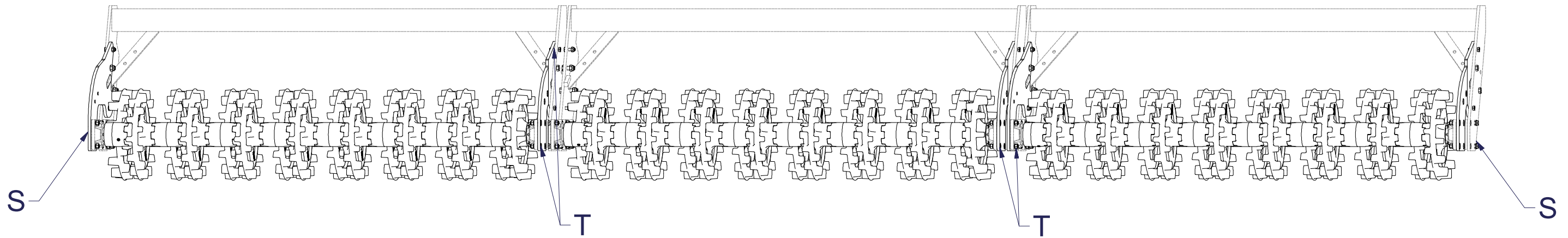

| Pos. | Part Number | Pcs. | Pos. | Part Number | Pcs. |
|------|-------------|------|------|-------------|------|
| 1 | 3009428 | 3 | 33 | m03519 | 44 |
| 2 | 3009429 | 3 | 40 | m01305 | 48 |
| 31 | m04412 | 4 | 50 | m17741 | 4 |
| | | | 51 | m03988 | 48 |

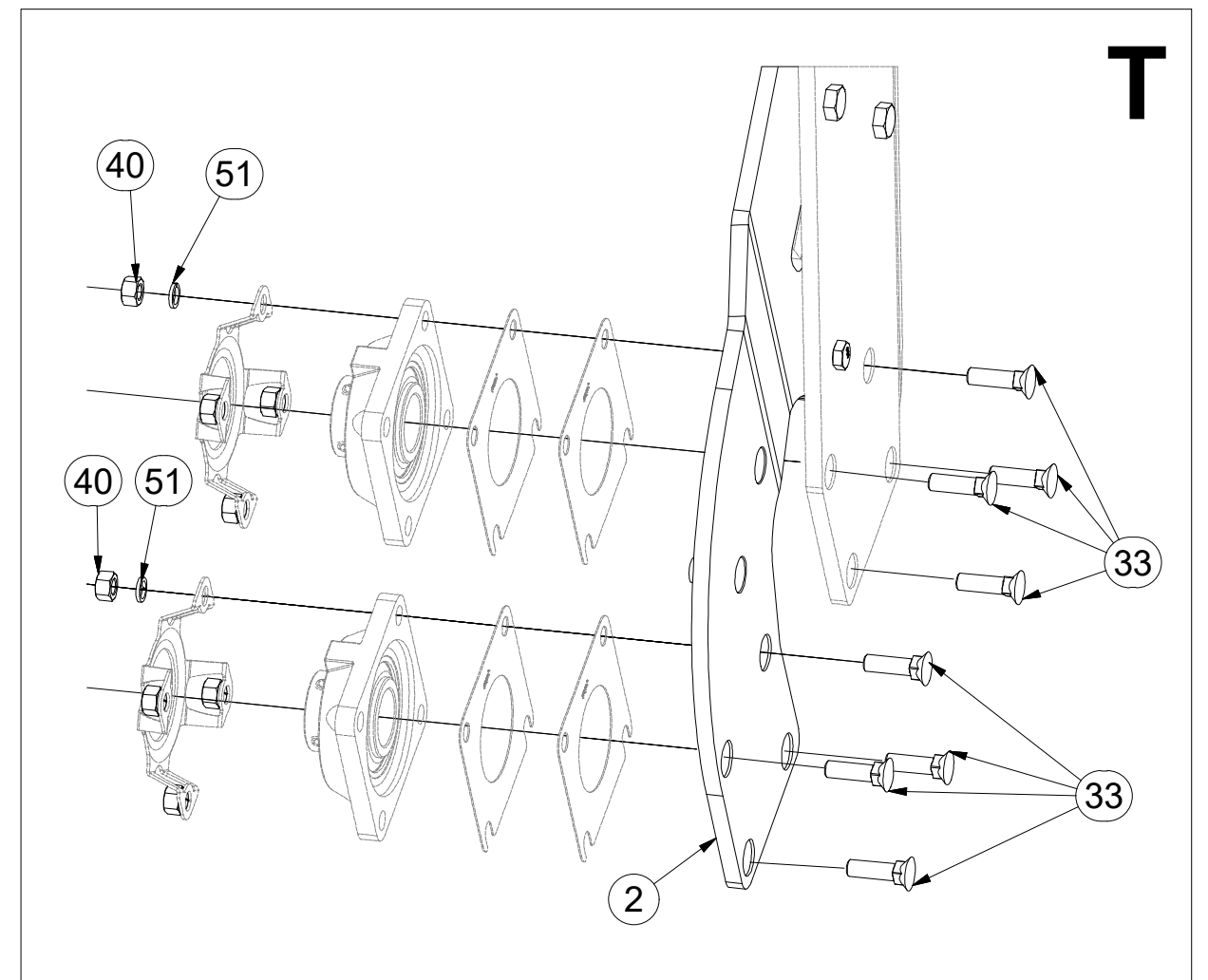
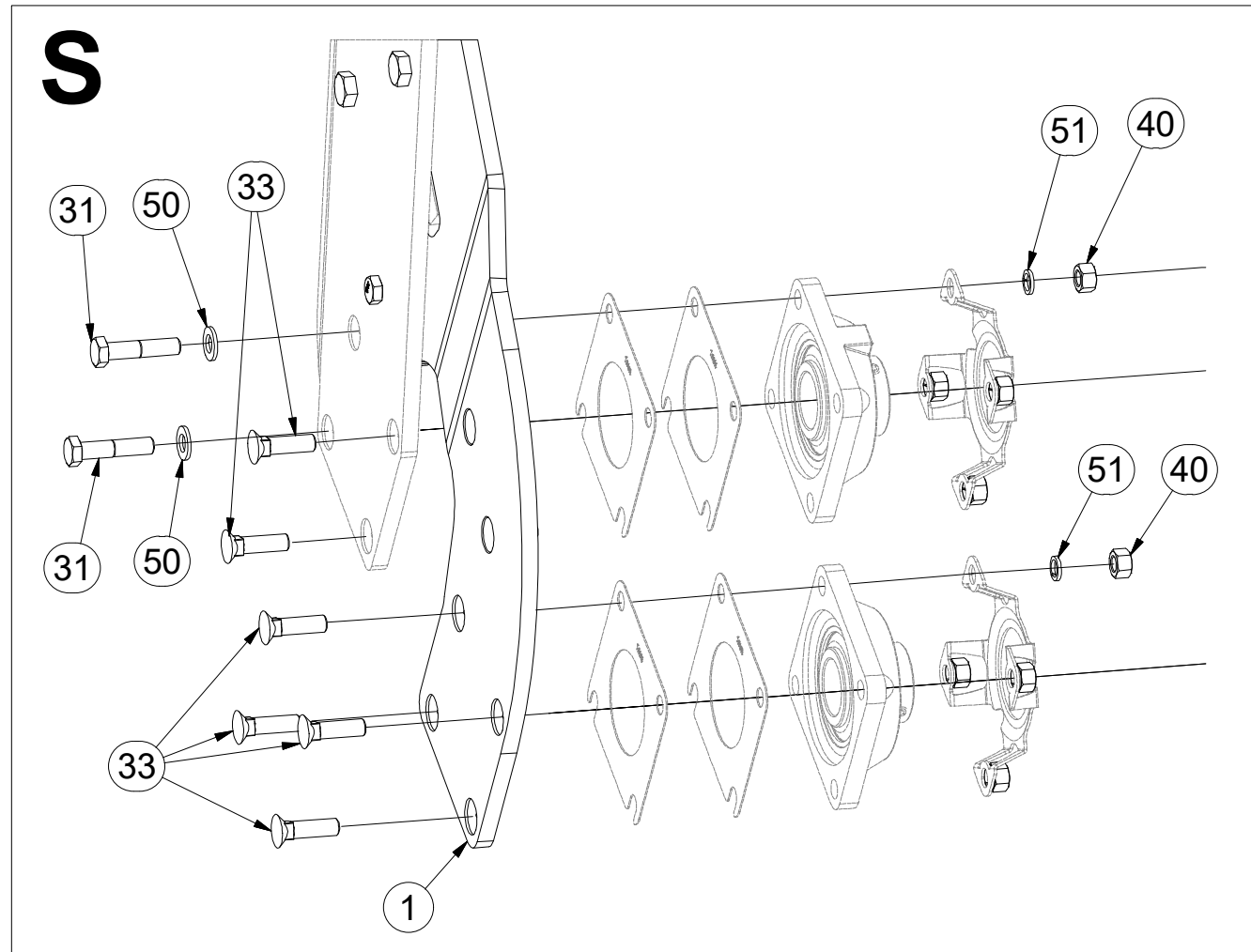

- Ⓒ SADA ZADNÍCH VÁLČŮ
- Ⓓ SATZ HINTERE WALZEN
- Ⓕ KIT DE ROULEAUX ARRIÈRE

- Ⓖ SET OF REAR ROLLERS
- Ⓡ КОМПЛЕКТ ЗАДНИХ КАТКОВ
- Ⓟ ZESTAW TYLNYCH WAŁÓW



3011862

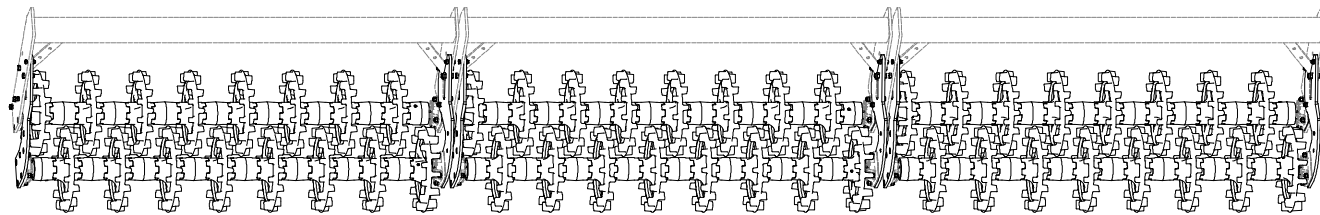

| Pos. | Part Number | Pcs. | Pos. | Part Number | Pcs. |
|------|-------------|------|------|-------------|------|
| 4 | 3011293 | 6 | 9 | 4016995 | 12 |
| 5 | 9002944 | 42 | 35 | m13958 | 24 |
| 6 | 4009333 | 6 | 100 | 4010015 | 24 |
| 7 | 4018228 | 42 | 101 | 4024556 | 24 |
| 8 | 4013129 | 6 | 120 | m10516 | 2,4 |

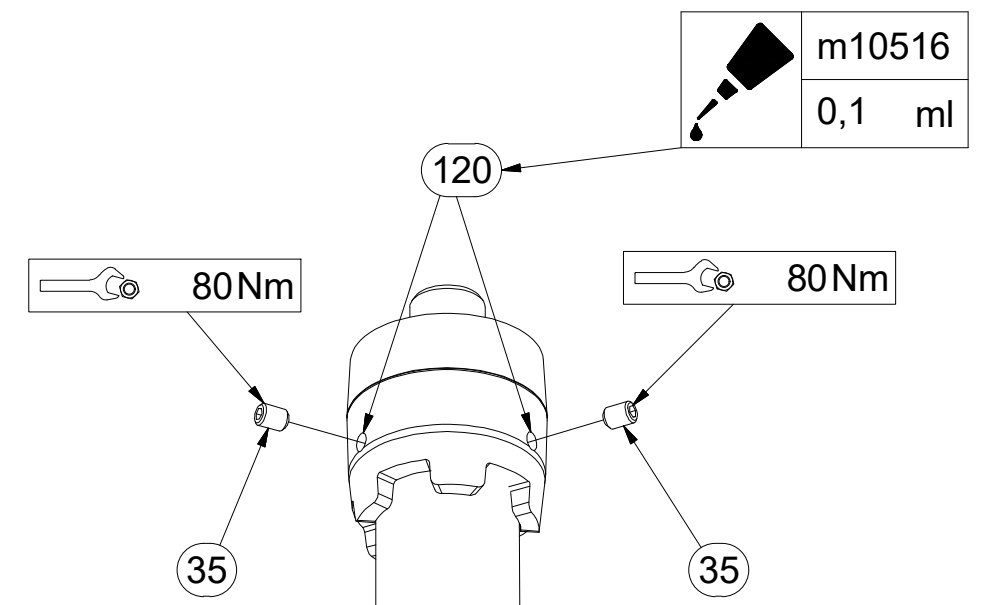
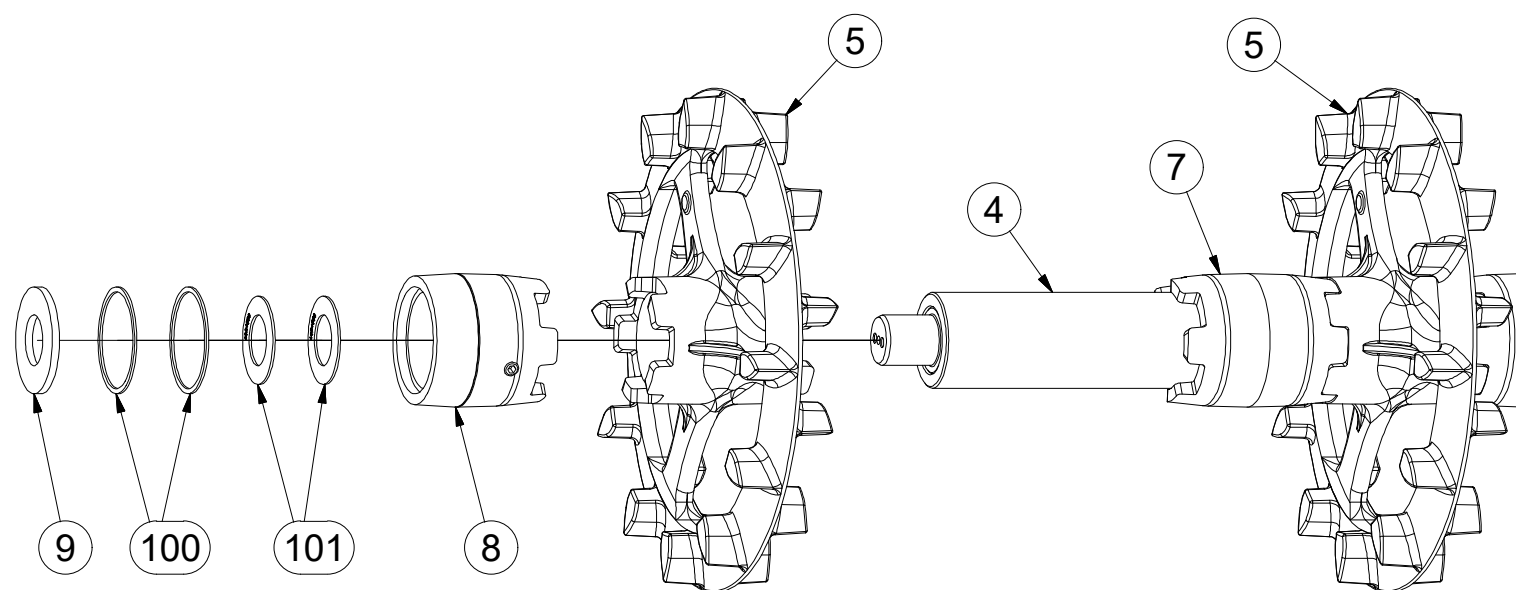
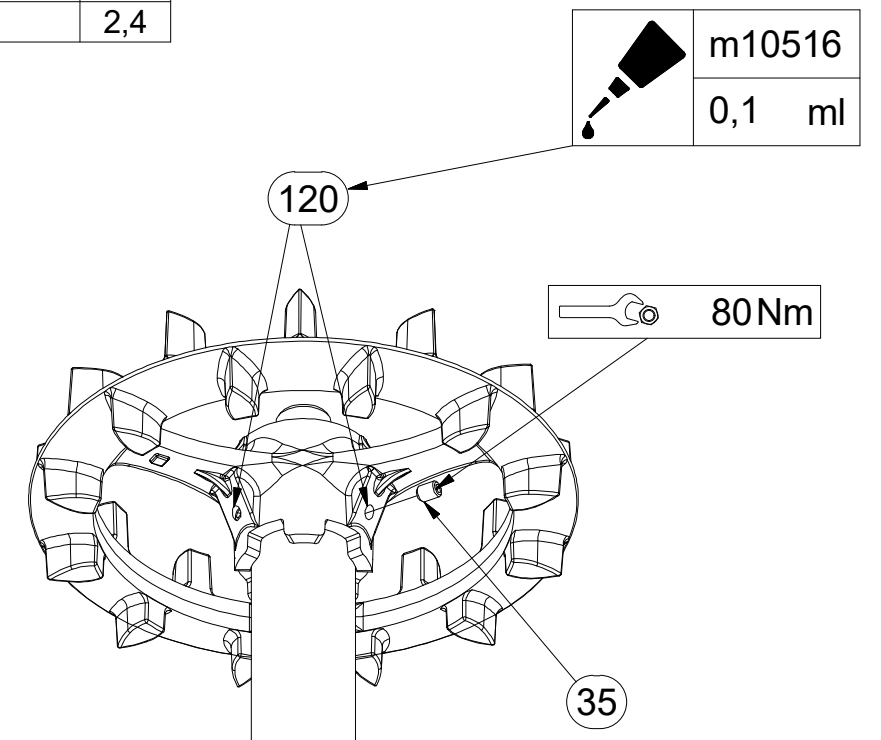
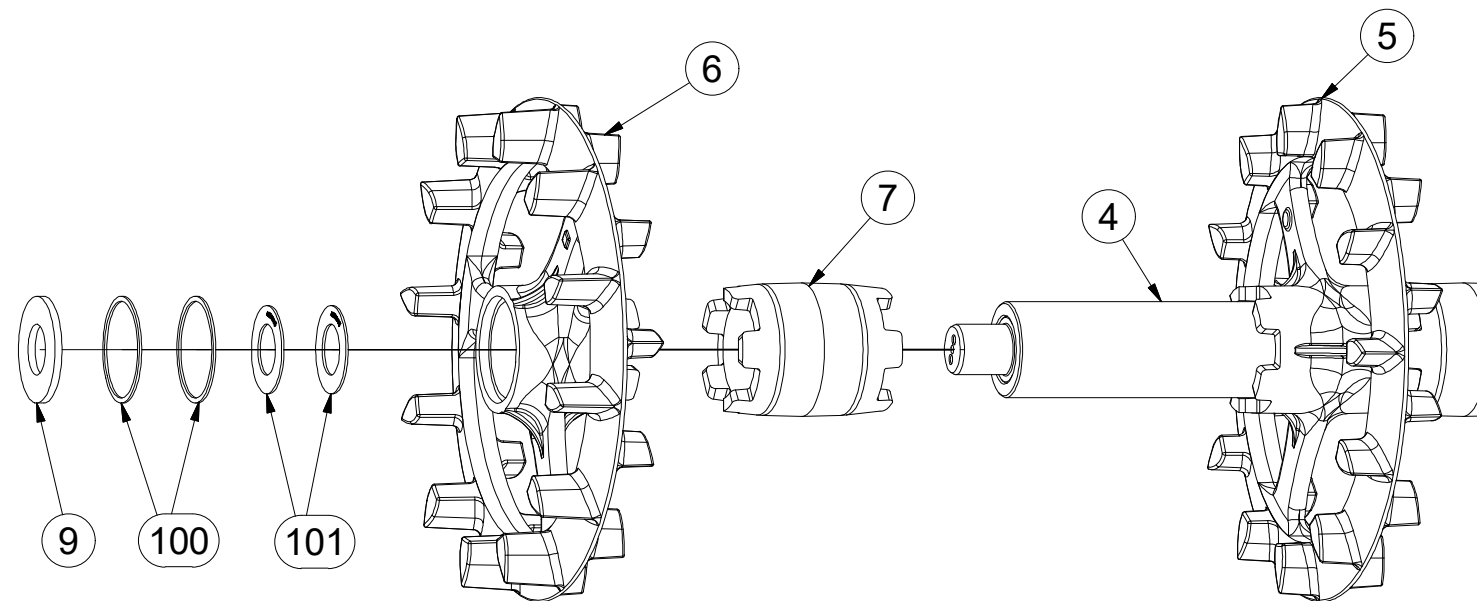

CZ SADA ZADNÍCH VÁLCŮ
 D SATZ HINTERE WALZEN
 F KIT DE ROULEAUX ARRIÈRE

GB SET OF REAR ROLLERS
 RU КОМПЛЕКТ ЗАДНИХ КАТКОВ
 PL ZESTAW TYLNYCH WAŁÓW



3011862

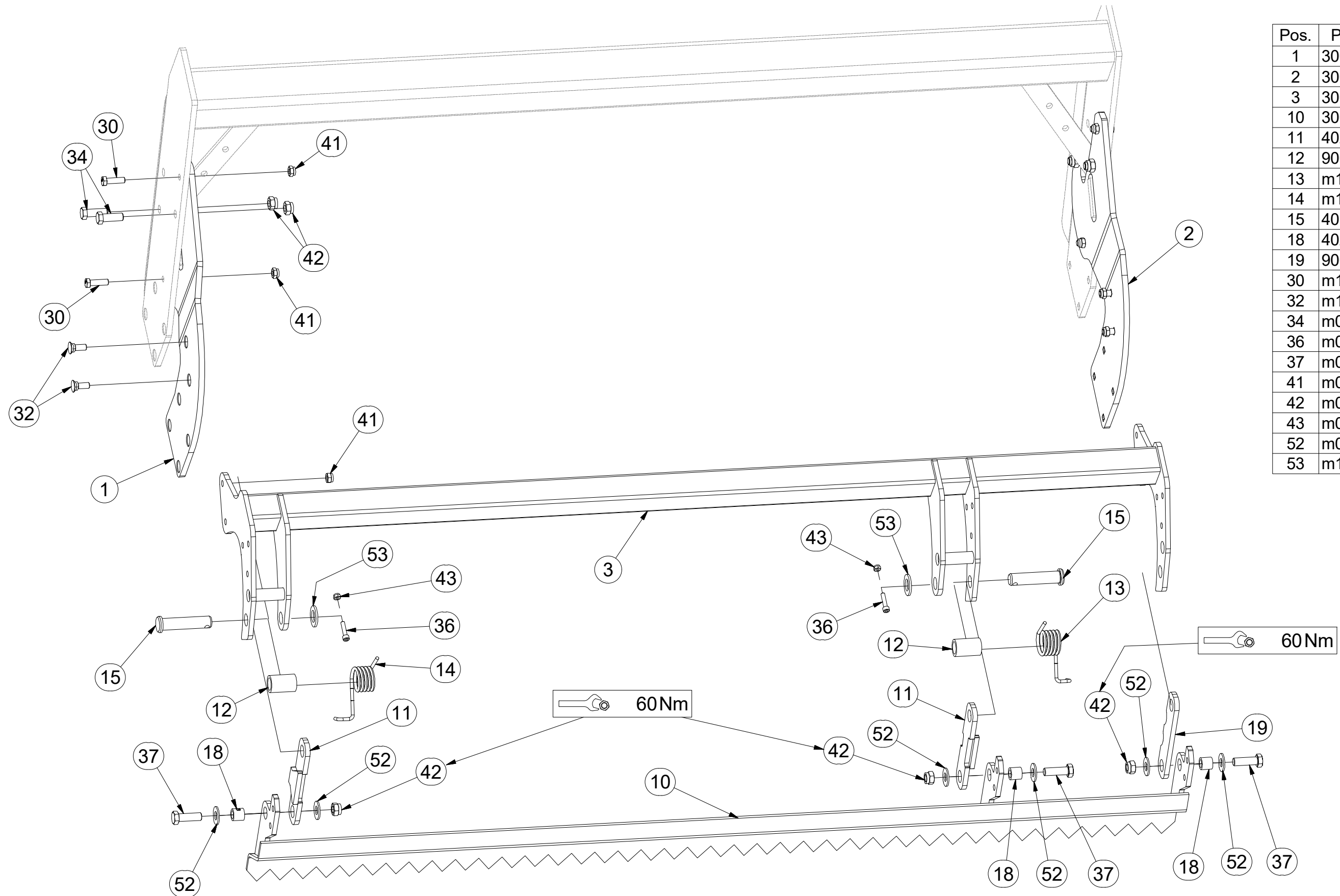

| Pos. | Part Number | Pcs. |
|------|-------------|------|
| 1 | 3009428 | 3 |
| 2 | 3009429 | 3 |
| 3 | 3006307 | 3 |
| 10 | 3006334 | 3 |
| 11 | 4024903 | 6 |
| 12 | 9002979 | 6 |
| 13 | m12303 | 3 |
| 14 | m12304 | 3 |
| 15 | 4015778 | 6 |
| 18 | 4022223 | 12 |
| 19 | 9003659 | 3 |
| 30 | m15618 | 12 |
| 32 | m13778 | 12 |
| 34 | m02254 | 12 |
| 36 | m09464 | 6 |
| 37 | m04355 | 12 |
| 41 | m04301 | 24 |
| 42 | m03683 | 24 |
| 43 | m04503 | 6 |
| 52 | m05651 | 24 |
| 53 | m14028 | 6 |

CZ SADA LOŽISEK
 D LAGERSATZ
 F KIT DE ROULEMENTS

GB SET OF BEARINGS
 RU КОМПЛЕКТ ПОДШИПНИКОВ
 PL ZESTAW ŁOŻYSK



3011890

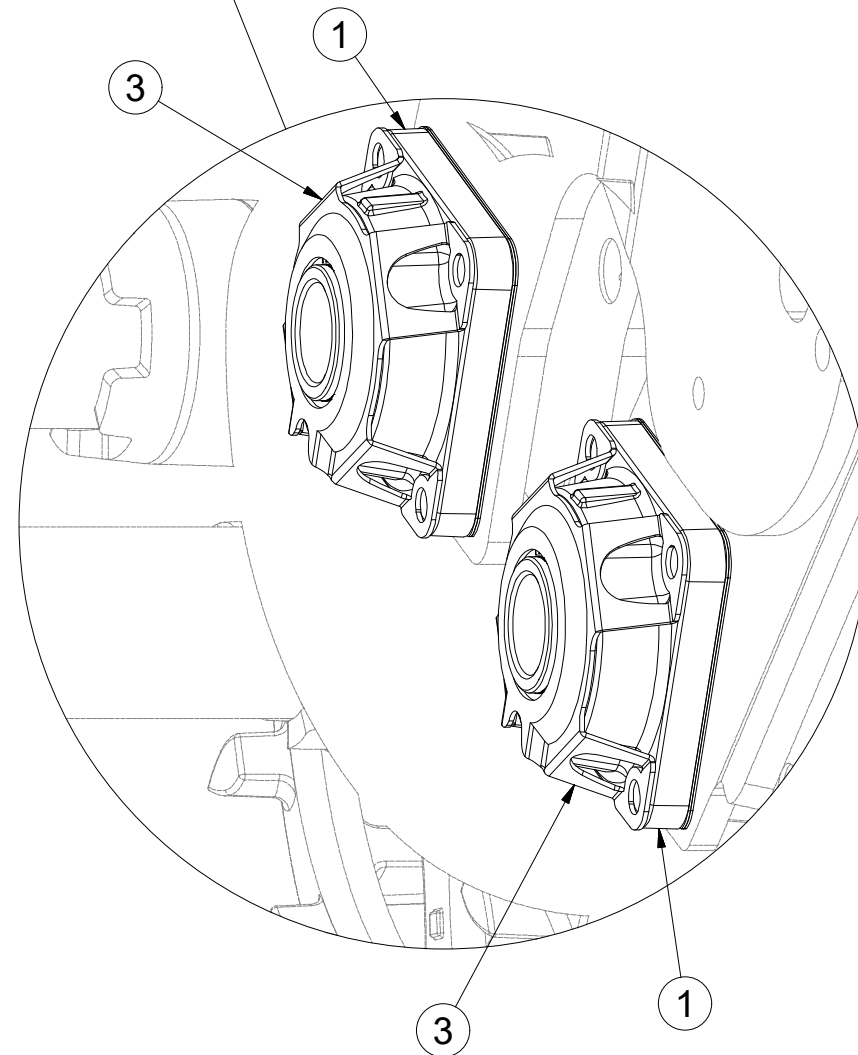
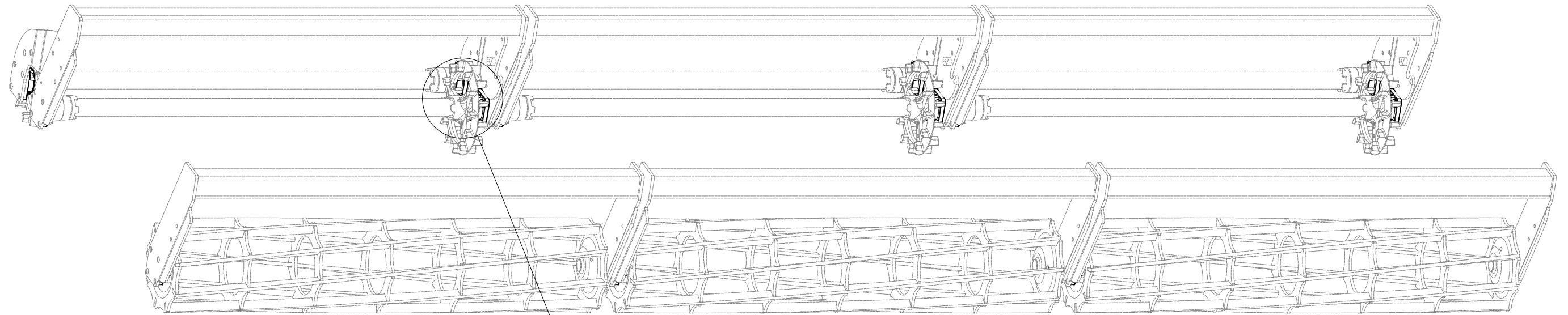

| Pos. | Part Number | Pcs. |
|------|-------------|------|
| 1 | m17341 | 18 |
| 3 | 4024047 | 18 |

- Ⓒ SADA LOŽISEK
- Ⓓ LAGERSATZ
- Ⓕ KIT DE ROULEMENTS

- Ⓒ SET OF BEARINGS
- Ⓔ КОМПЛЕКТ ПОДШИПНИКОВ
- Ⓖ ZESTAW ŁOŻYSK



3011890

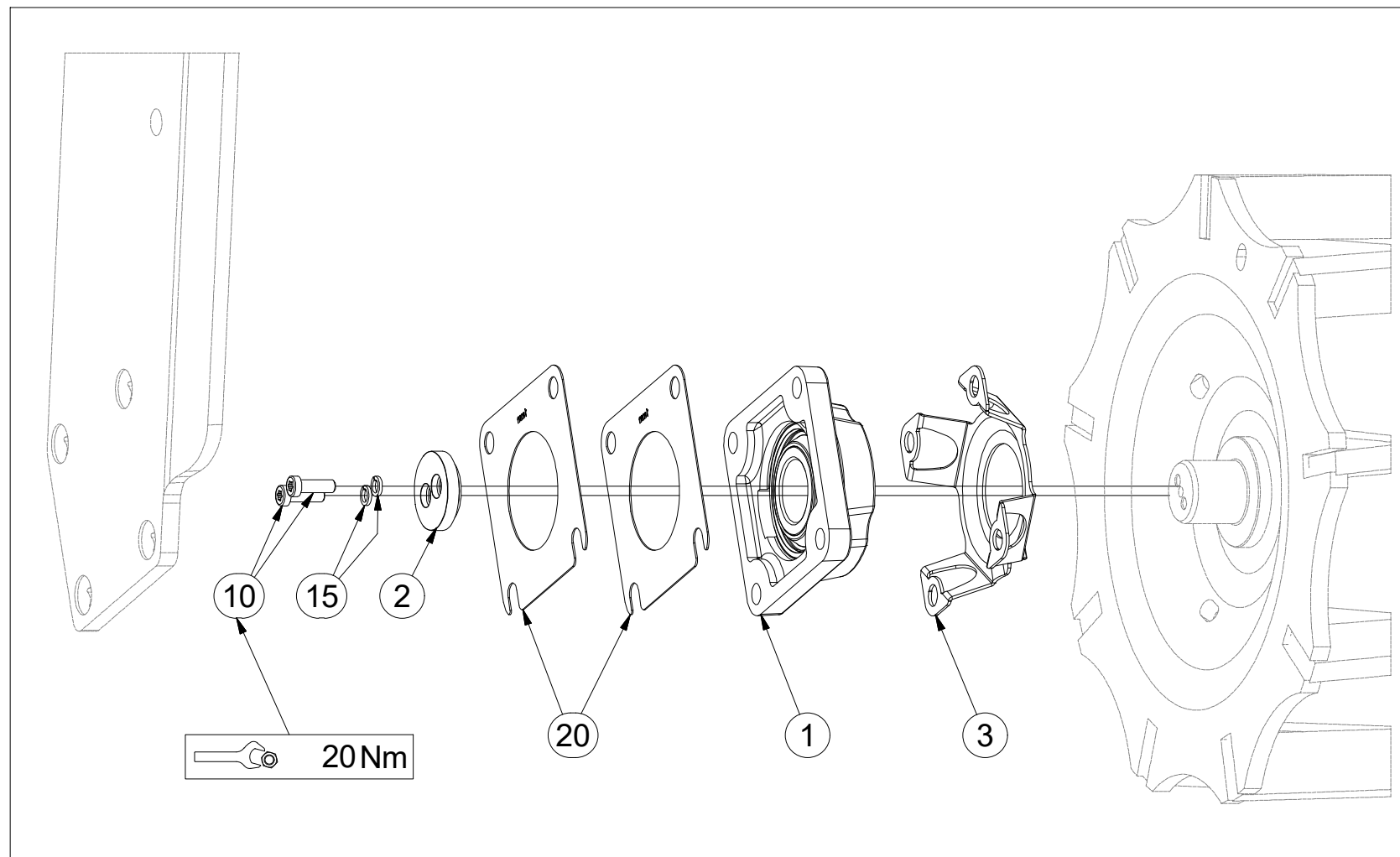
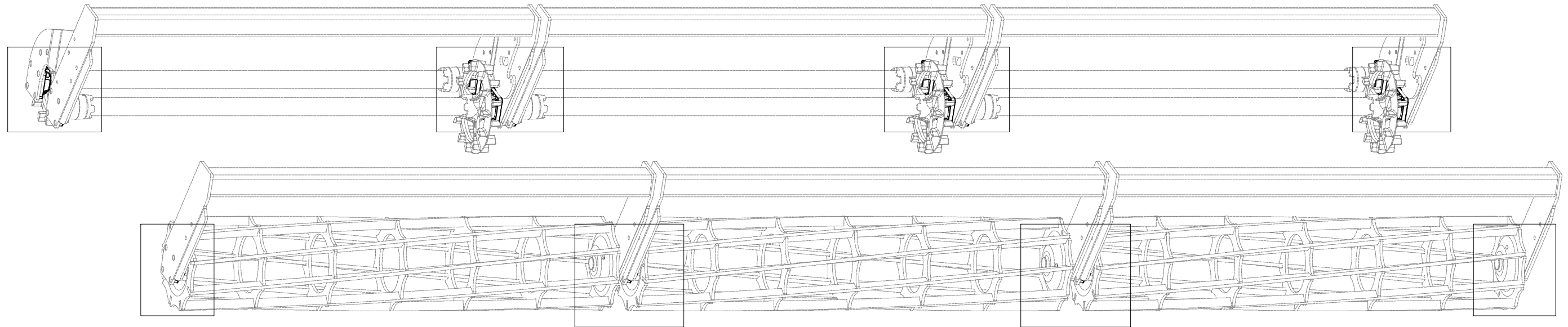

| Pos. | Part Number | Pcs. |
|------|-------------|------|
| 1 | m17341 | 18 |
| 2 | 4024753 | 18 |
| 3 | 4024047 | 18 |
| 10 | m18858 | 36 |
| 15 | m01202 | 36 |
| 20 | 4016809 | 36 |

ⒸZ SADA DORAZŮ ZADNÍCH SMYKŮ

Ⓓ ANSCHLAGSATZ FÜR HINTERE ACKERSCHLEPPEN

Ⓕ KIT DE BUTÉES DES NIVELEURS ARRIÈRE

ⒼB SET OF REAR LEVELLING BAR STOPS

ⒺU КОМПЛЕКТ УПОРОВ ЗАДНИХ БОРОН

ⒼL ZESTAW DOCISKÓW TYLNYCH WŁÓK



3006133

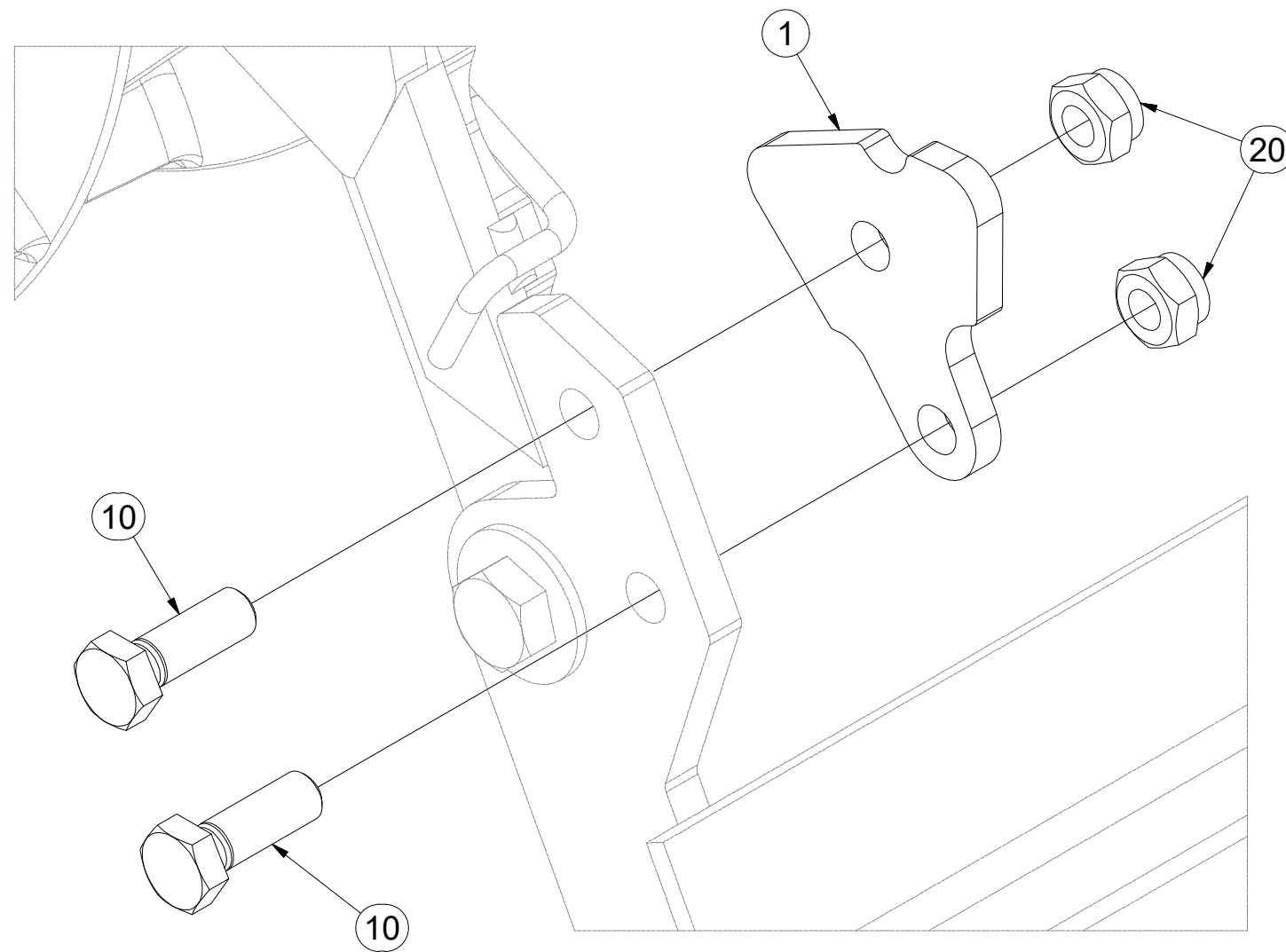
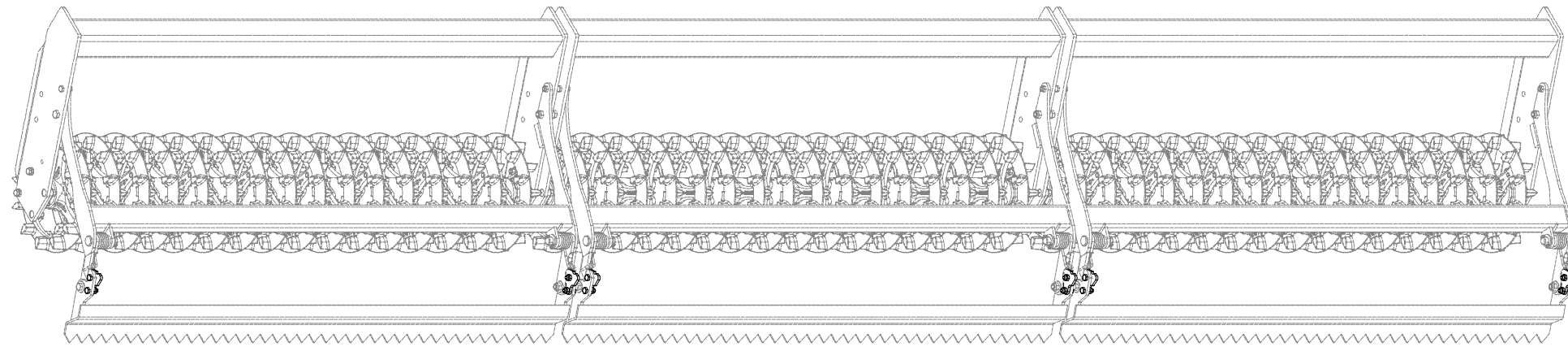

| Pos. | Part Number | Pcs. |
|------|-------------|------|
| 1 | 4009757 | 6 |
| 10 | m04343 | 12 |
| 20 | m04301 | 12 |

ⒸZ SADA NÁPRAVY

Ⓓ SATZ AUFHÄNGUNG

Ⓕ KIT DE L'ESSIEU

ⒸB AXLE SET

Ⓔ КОМПЛЕКТ ОСИ КОЛЁС

Ⓗ ZESTAW OSI



3012508

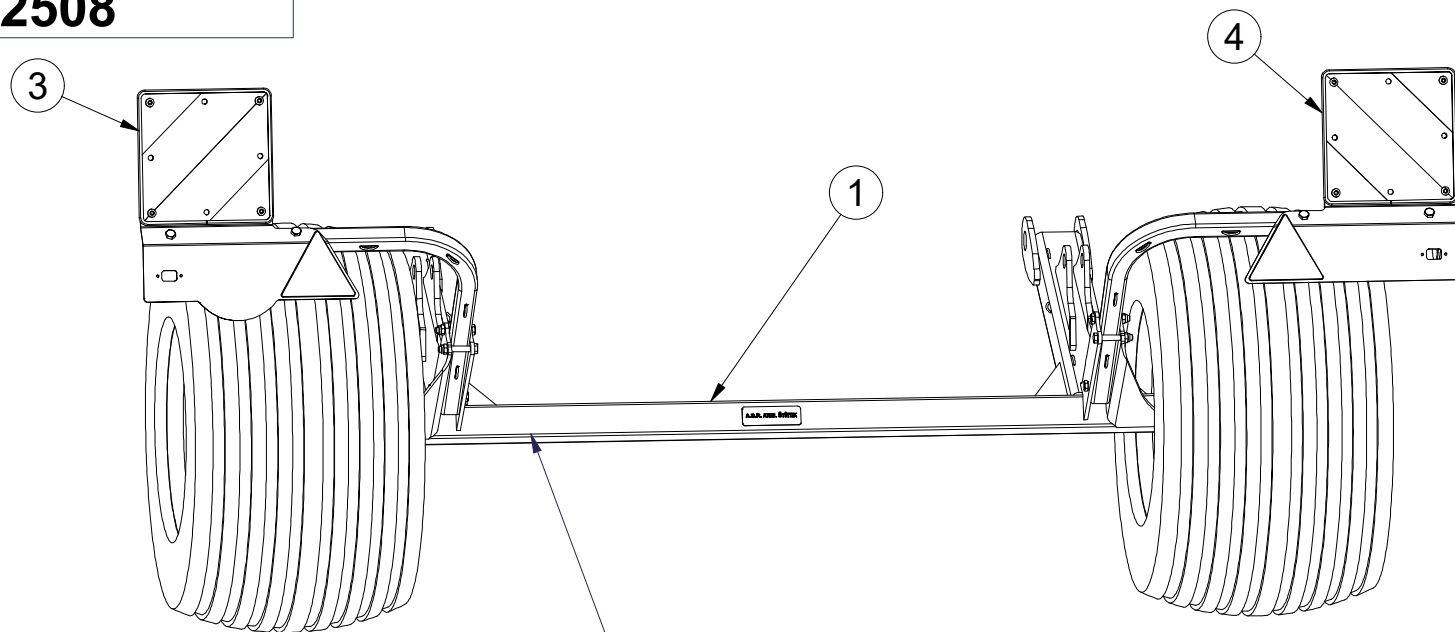

| Pos. | Part Number | Pcs. |
|------|-------------|------|
| 1 | 3012422 | 1 |
| 2 | m11625 | 2 |
| 3 | 3012431 | 1 |
| 4 | 3012432 | 1 |
| 15 | m12493 | 6 |
| 20 | m04301 | 6 |
| 25 | m19657 | 12 |
| 30 | m19732 | 2 |

A70MR6

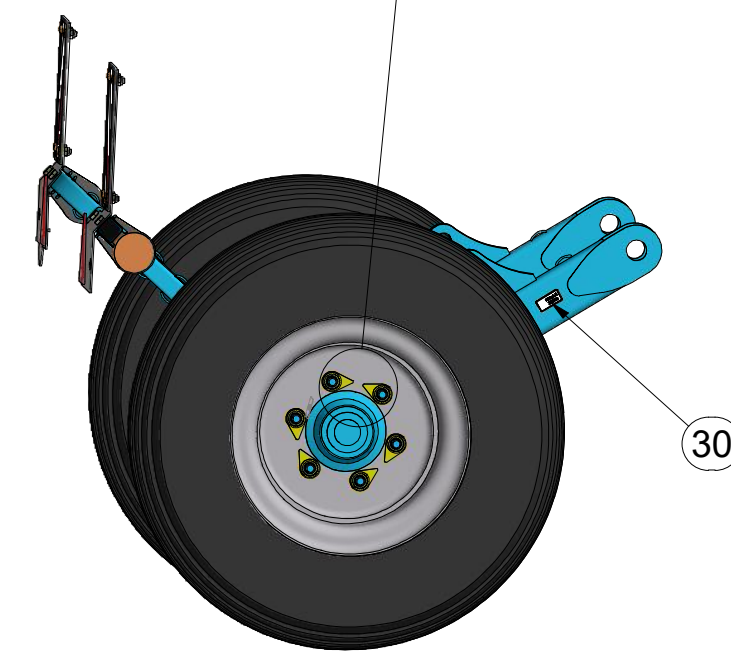
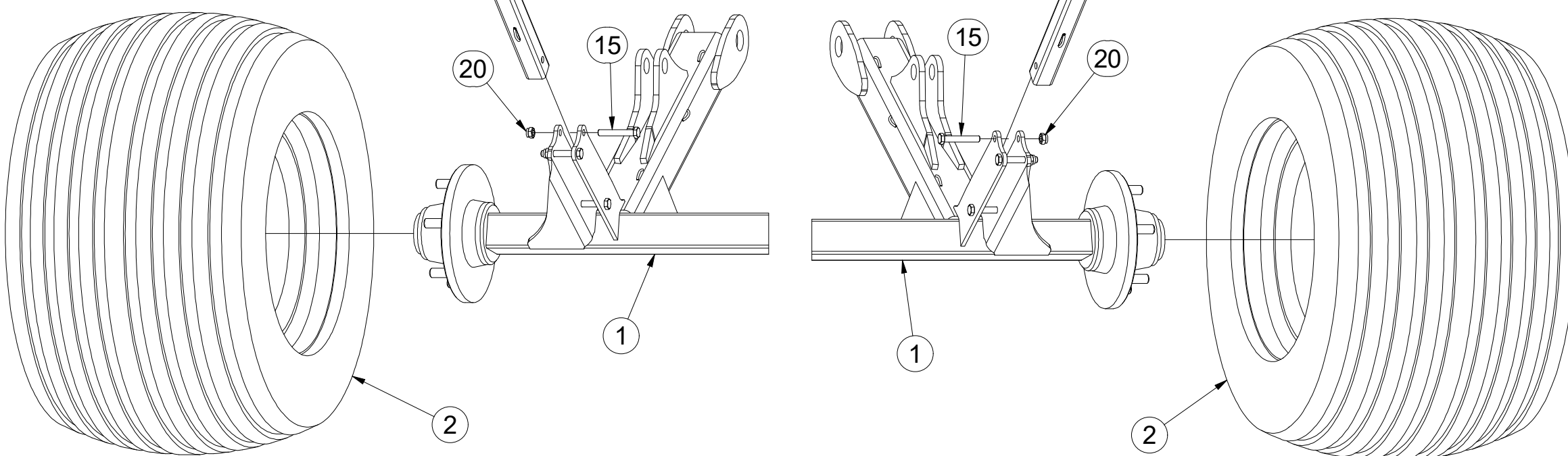
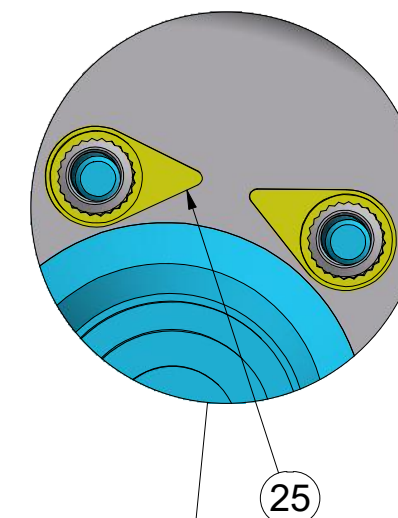

ⒸZ NÁPRAVA

ⒹACHSE

ⒻESSIEU

ⒸGB AXLE

ⒸRU OCB

ⒸPL OS



A70MR06

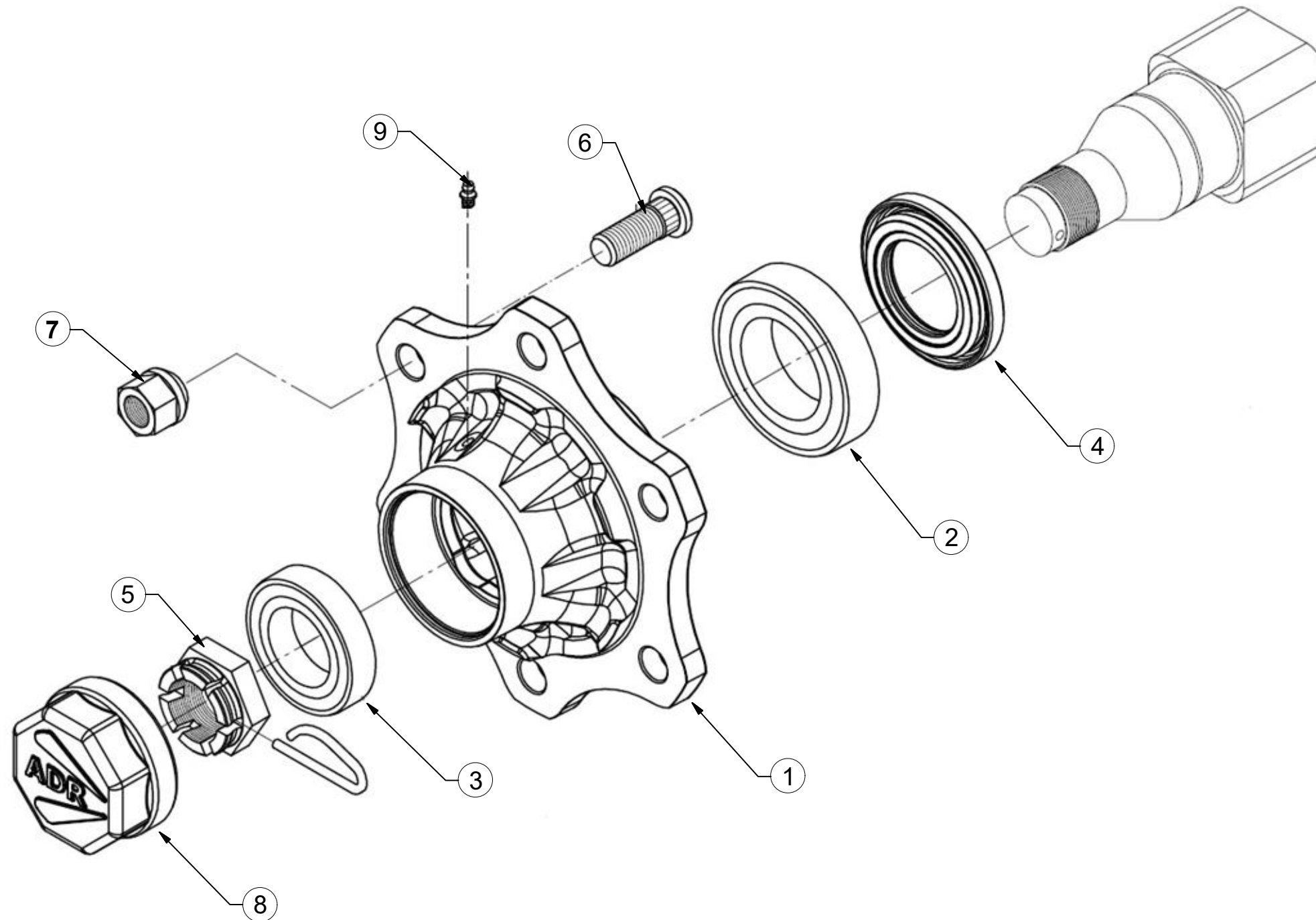

| Pos | Part Number | Pcs. |
|-----|-------------|------|
| 1 | m19667 | 2 |
| 2 | m08194 | 2 |
| 3 | m07152 | 2 |
| 4 | m14924 | 2 |
| 5 | m08169 | 2 |
| 6 | m08148 | 12 |
| 7 | m08163 | 12 |
| 8 | m19668 | 2 |
| 9 | m05698 | 2 |

Ⓒ SADA NÁPRAVY

Ⓓ SATZ AUFHÄNGUNG

Ⓕ KIT DE L'ESSIEU

m11625

Ⓖ AXLE SET

Ⓡ КОМПЛЕКТ ОСИ КОЛЁС

Ⓟ ZESTAW OSI

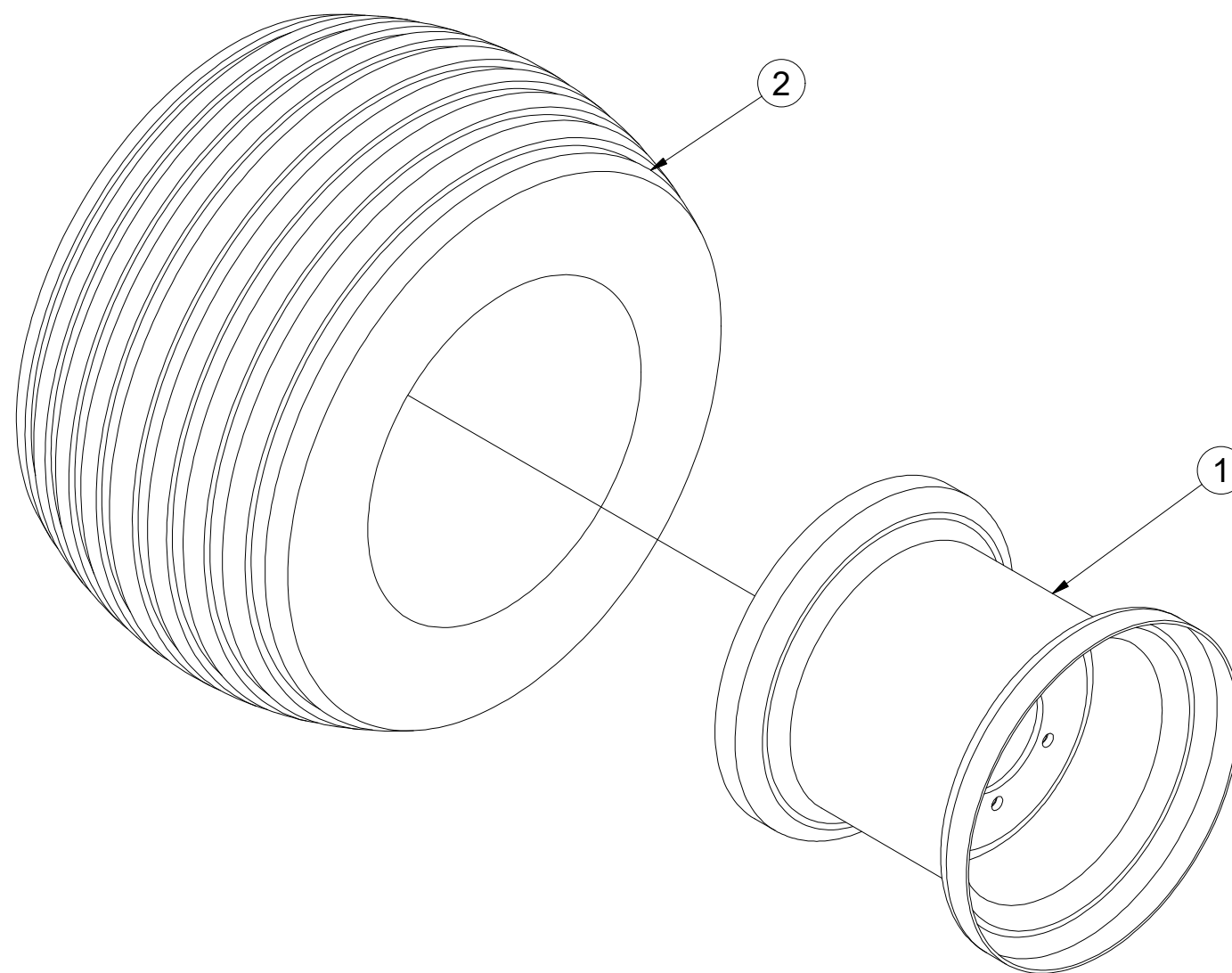

| Pos. | Part Number | Pcs. |
|------|-------------|------|
| 1 | m13089 | 1 |
| 2 | m07707 | 1 |

ⒸZ TERČ ZADNÍ LEVÝ - HOMOLOGACE

Ⓓ SCHILD, HINTERES, LINKES - HOMOLOGATION

Ⓕ CIBLE ARRIÈRE GAUCHE - HOMOLOGATION

3012498

ⒸB LEFT REAR DISC - HOMOLOGATION

Ⓔ ЩИТОК ЗАДНИЙ ЛЕВЫЙ - УТВЕРЖДЕНИЯ

Ⓖ TARCZA TYLNA LEWA - HOMOLOGACJA

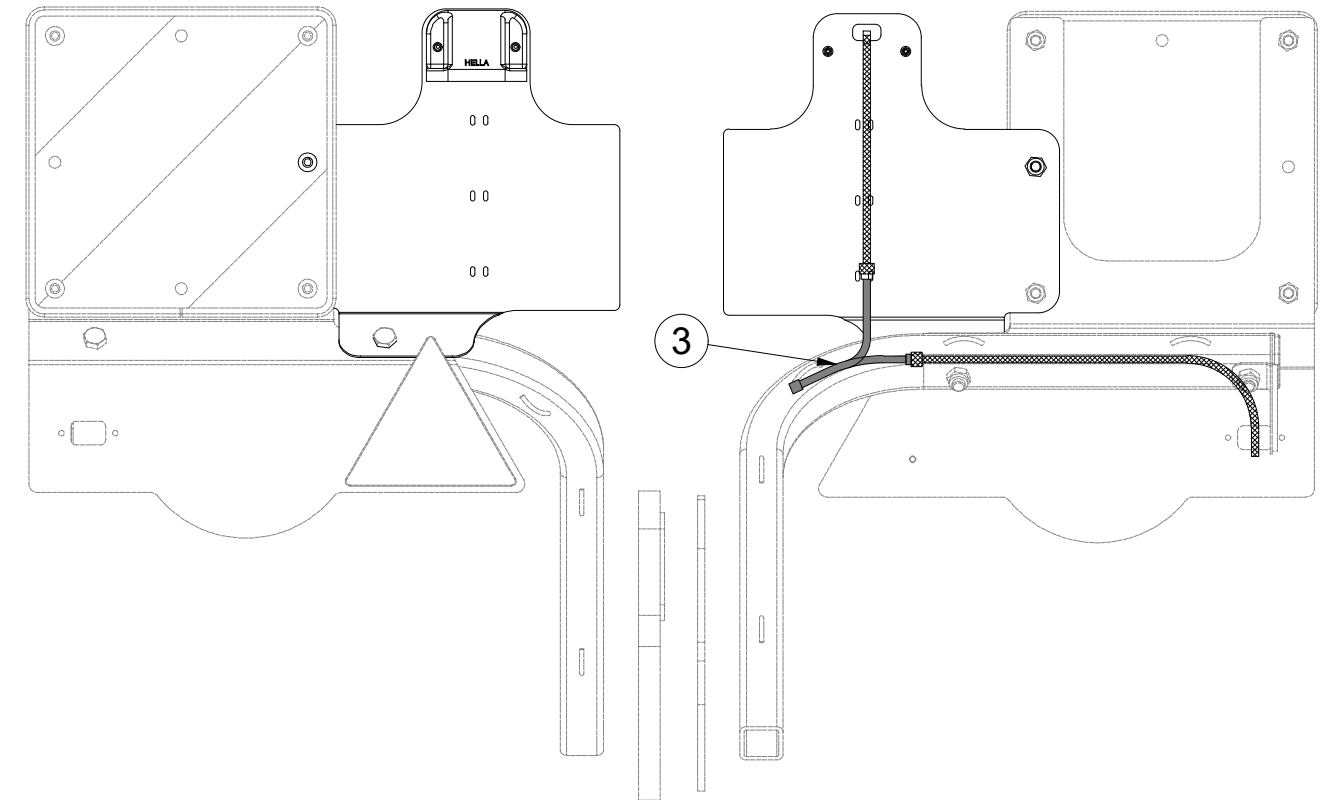
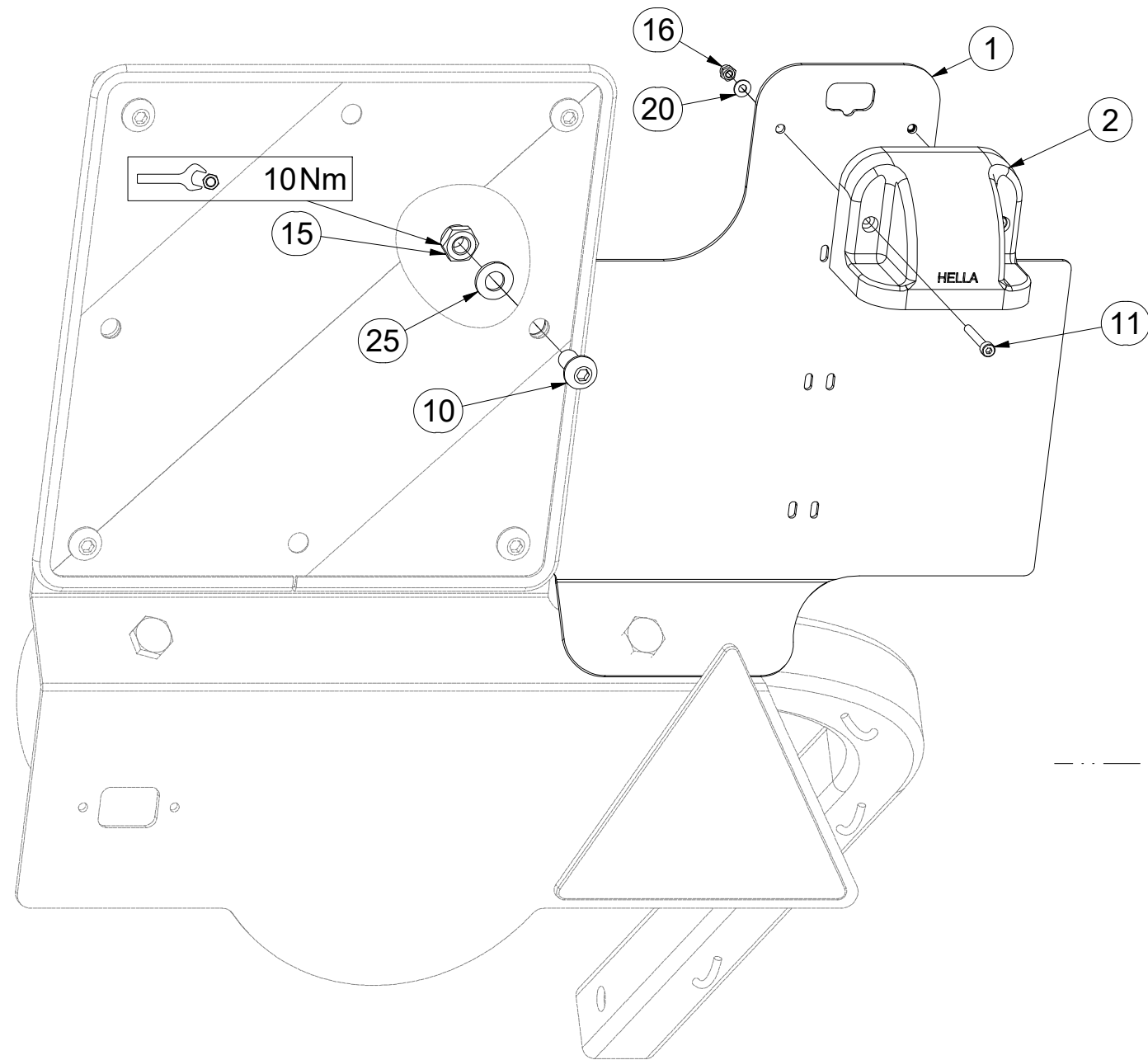

| Pos. | Part Number | Pcs. | Pos. | Part Number | Pcs. |
|------|-------------|------|------|-------------|------|
| 1 | 3012366 | 1 | 11 | m16861 | 2 |
| 2 | m18862 | 1 | 15 | m03775 | 1 |
| 3 | m18861 | 1 | 16 | m05562 | 2 |
| 4 | m18814 | 1 | 20 | m05597 | 2 |
| 5 | 4025903 | 1 | 25 | m01209 | 1 |
| 10 | m16637 | 1 | | | |

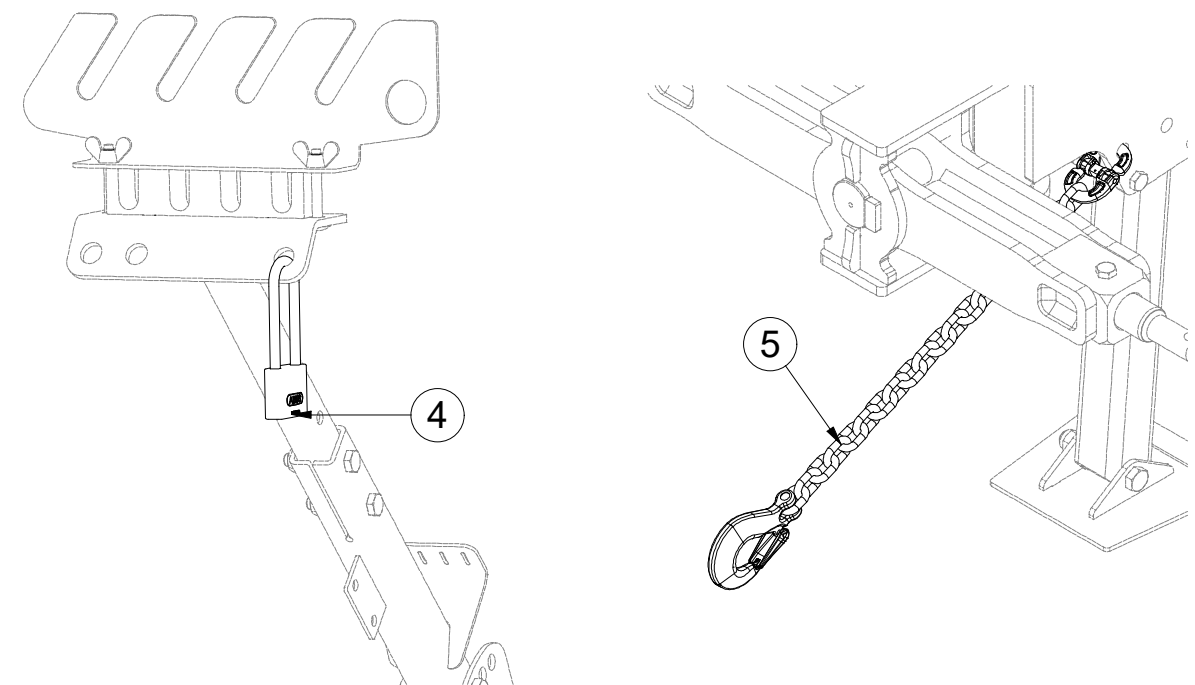

ⒸZ TERČ ZADNÍ LEVÝ

Ⓓ SCHILD, HINTERES, LINKES

Ⓕ CIBLE ARRIÈRE GAUCHE

3012431

ⒼB LEFT REAR DISC

ⒺЩИТОК ЗАДНИЙ ЛЕВЫЙ

ⒽL TARCZA TYLNA LEWA

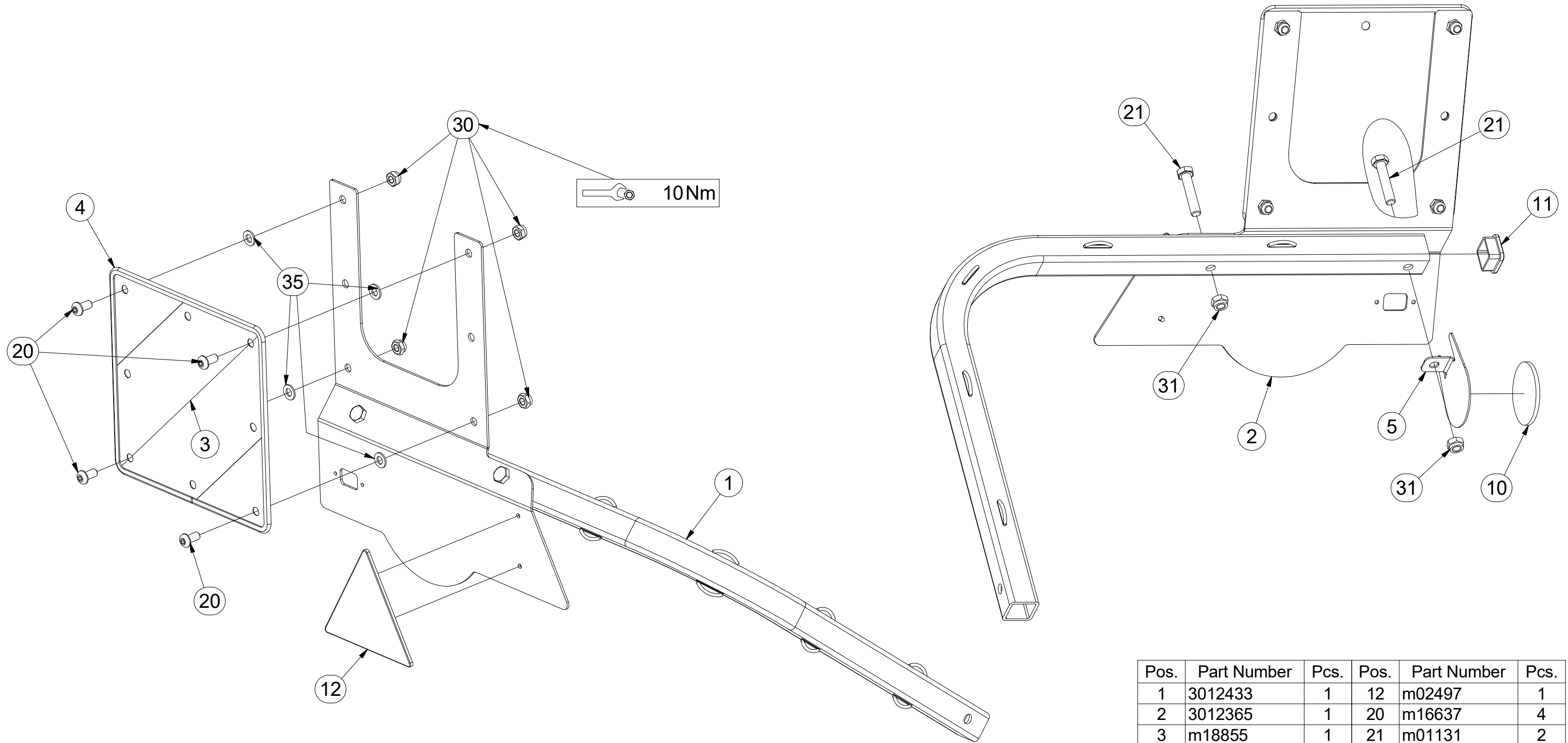

| Pos. | Part Number | Pcs. | Pos. | Part Number | Pcs. |
|------|-------------|------|------|-------------|------|
| 1 | 3012433 | 1 | 12 | m02497 | 1 |
| 2 | 3012365 | 1 | 20 | m16637 | 4 |
| 3 | m18855 | 1 | 21 | m01131 | 2 |
| 4 | 9005707 | 1 | 30 | m03775 | 4 |
| 5 | 4024926 | 1 | 31 | m04301 | 2 |
| 10 | m02579 | 1 | 35 | m01209 | 4 |
| 11 | m12689 | 1 | | | |

ⒸZ TERČ ZADNÍ PRAVÝ

Ⓓ SCHILD, HINTERES, RECHTES

Ⓕ CIBLE ARRIÈRE DROITE

ⒼB RIGHT REAR DISC

ⒶU ЩИТОК ЗАДНИЙ ПРАВЫЙ

ⒶL TARCZA TYLNA PRAWA



3012432

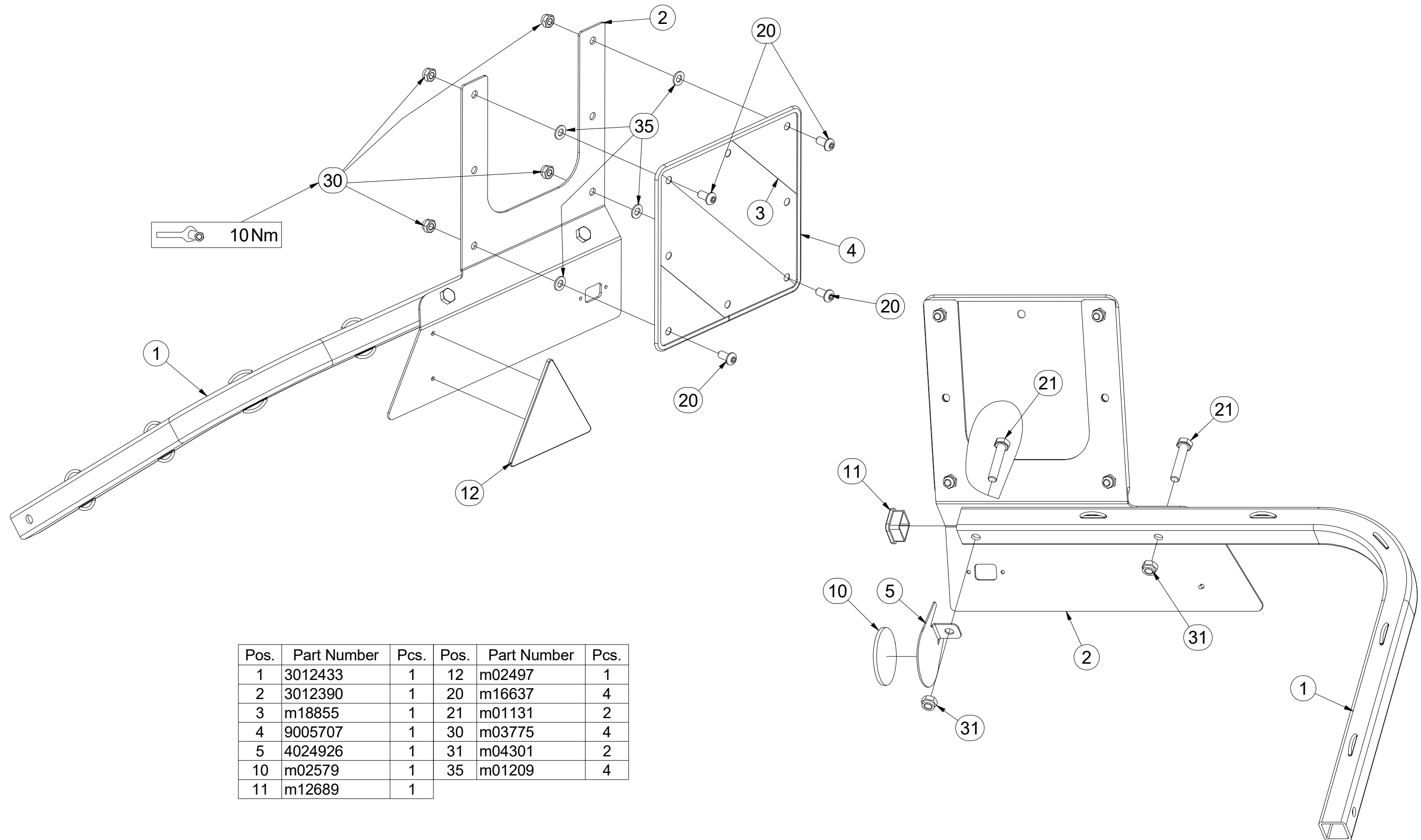

| Pos. | Part Number | Pcs. | Pos. | Part Number | Pcs. |
|------|-------------|------|------|-------------|------|
| 1 | 3012433 | 1 | 12 | m02497 | 1 |
| 2 | 3012390 | 1 | 20 | m16637 | 4 |
| 3 | m18855 | 1 | 21 | m01131 | 2 |
| 4 | 9005707 | 1 | 30 | m03775 | 4 |
| 5 | 4024926 | 1 | 31 | m04301 | 2 |
| 10 | m02579 | 1 | 35 | m01209 | 4 |
| 11 | m12689 | 1 | | | |

Ⓒ SAMOLEPKY STROJE
Ⓓ AUFKLEBER MASCHINEN
Ⓕ VOITURE MACHINES

Ⓒ STICKERS MACHINES
Ⓓ СТИКЕРЫ МАШИНЫ
Ⓕ NAKLEJKI MASZYNY



4025230

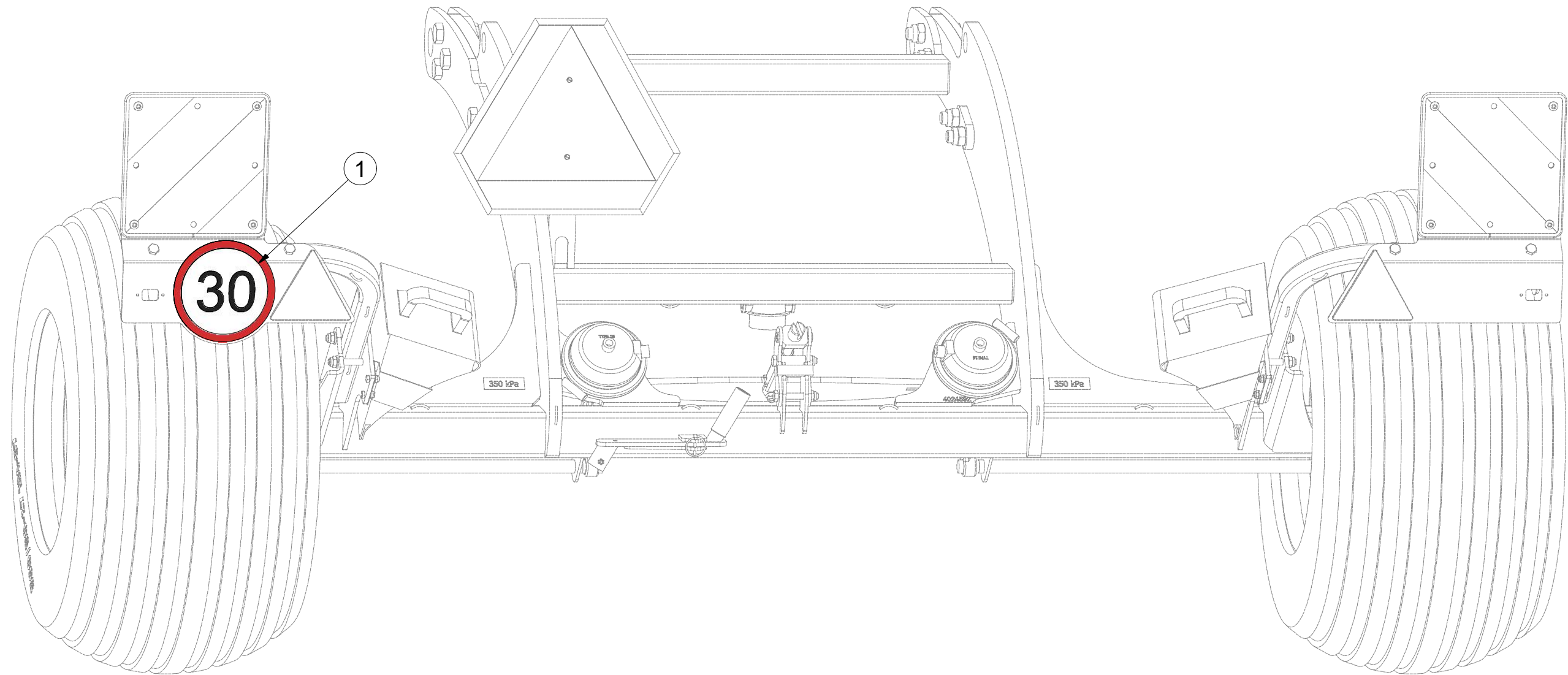

| Pos. | Part Number | Pcs. |
|------|-------------|------|
| 1 | m19161 | 1 |

ⒸZ SOUPRAVA TĚSNIVA PÍSTNIC

Ⓓ KOLBENSTANGENDICHTUNGSMITTELSATZ

Ⓕ SET DE GARNITURE DES TIGES DE PISTON

ⒼB SEALING SET FOR PISTON RODS

ⒺU КОМПЛЕКТ ПРОКЛАДОК ЦИЛИНДРОВ

ⒼL ZESTAW USZCZELEK TRZPIENIA TŁOKA

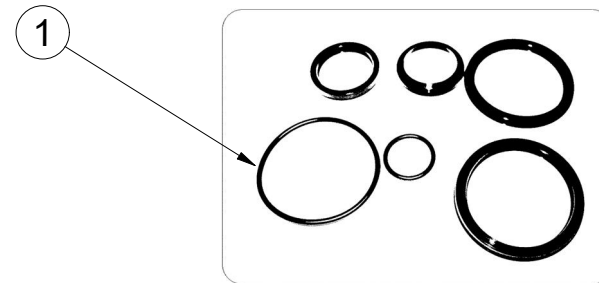
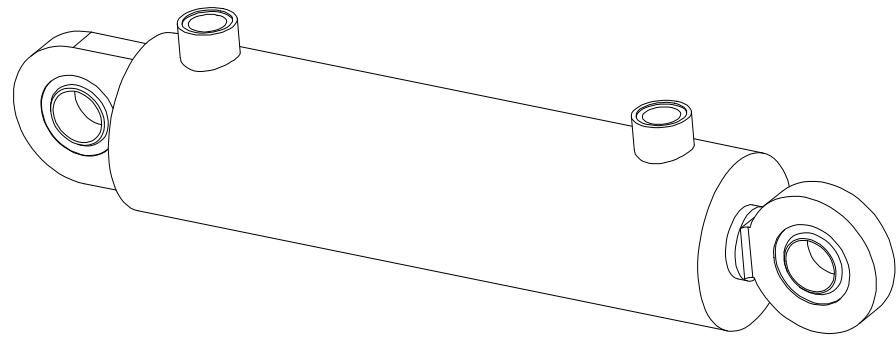

| VZ00004549- Ø80/Ø40-250/455/705 | | |
|---------------------------------|-------------|-----|
| Pos | Part number | Pcs |
| 1 | m03528 | 2 |

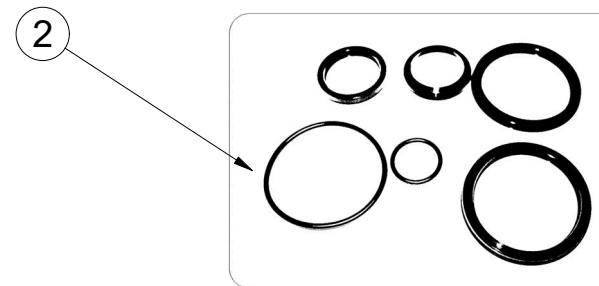
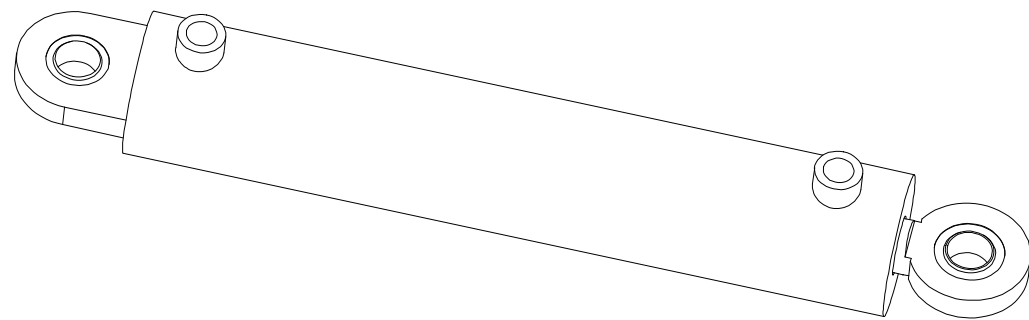

| VZ00004544- Ø80/Ø40-400/605/1005 | | |
|----------------------------------|-------------|-----|
| Pos | Part number | Pcs |
| 2 | m03528 | 2 |

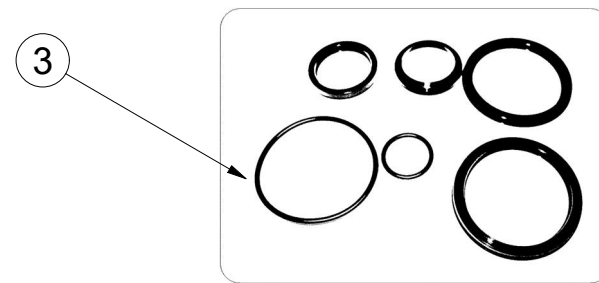
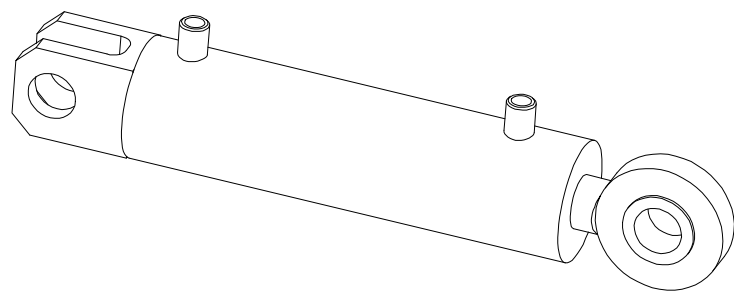

| 8000734-90007 - Ø40/Ø22-100 | | |
|-----------------------------|-------------|-----|
| Pos | Part number | Pcs |
| 3 | m05676 | 6 |

Ⓒ SVĚTELNÁ SADA

Ⓓ LEUCHTENSATZ

Ⓕ KIT LUMINEUX

Ⓖ LIGHTING SET

Ⓡ ОСВЕТИТЕЛЬНЫЙ КОМПЛЕКТ

Ⓟ ZESTAW OŚWIETLENIA



3012429

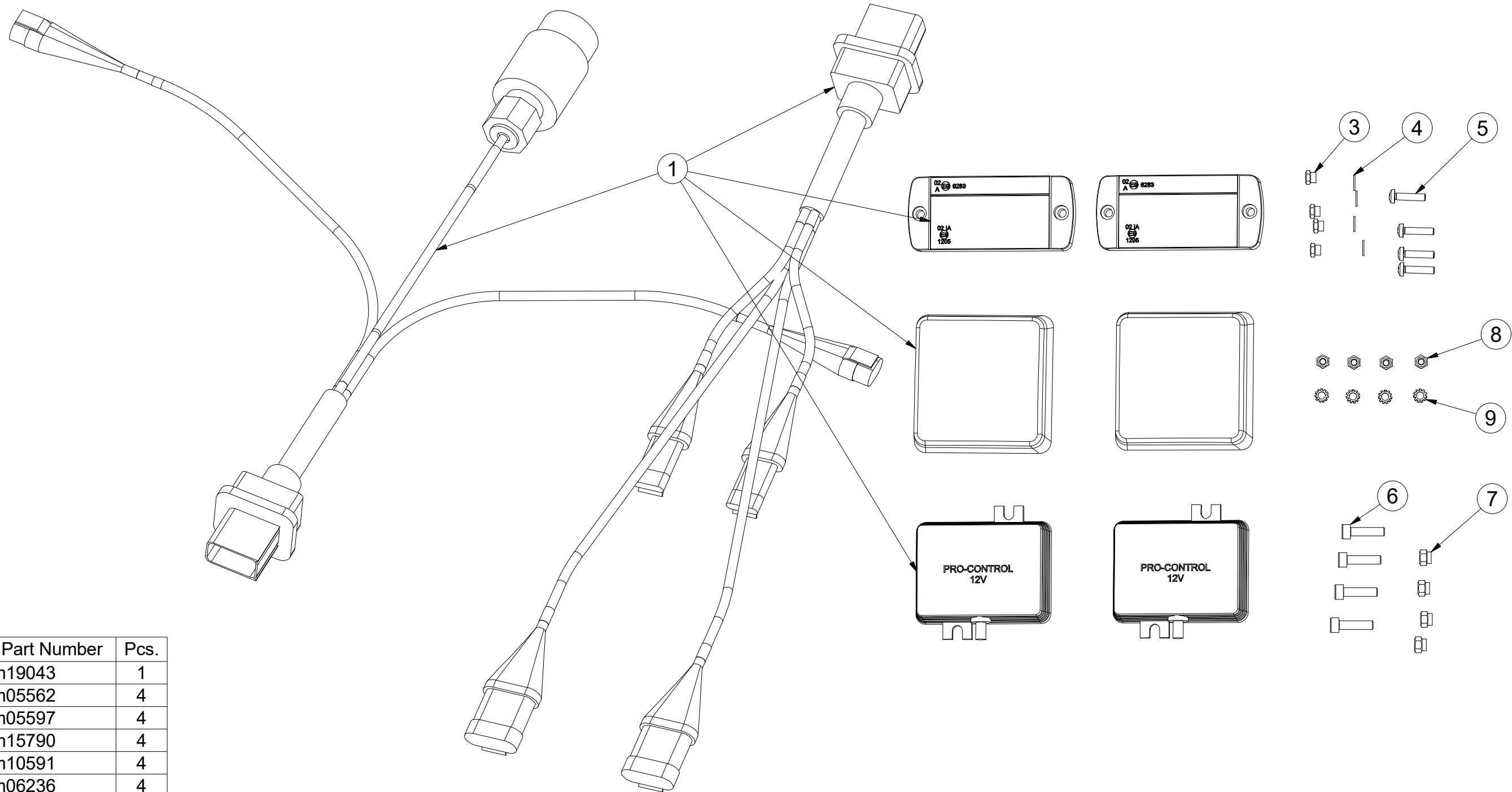

| Pos. | Part Number | Pcs. |
|------|-------------|------|
| 1 | m19043 | 1 |
| 3 | m05562 | 4 |
| 4 | m05597 | 4 |
| 5 | m15790 | 4 |
| 6 | m10591 | 4 |
| 7 | m06236 | 4 |
| 8 | m05081 | 4 |
| 9 | m05595 | 4 |

Ⓒ SVĚTELNÁ SADA

Ⓓ LEUCHTENSATZ

Ⓕ KIT LUMINEUX

3012429

Ⓒ LIGHTING SET

Ⓔ ОСВЕТИТЕЛЬНЫЙ КОМПЛЕКТ

Ⓖ ZESTAW OŚWIETLENIA

Farmet

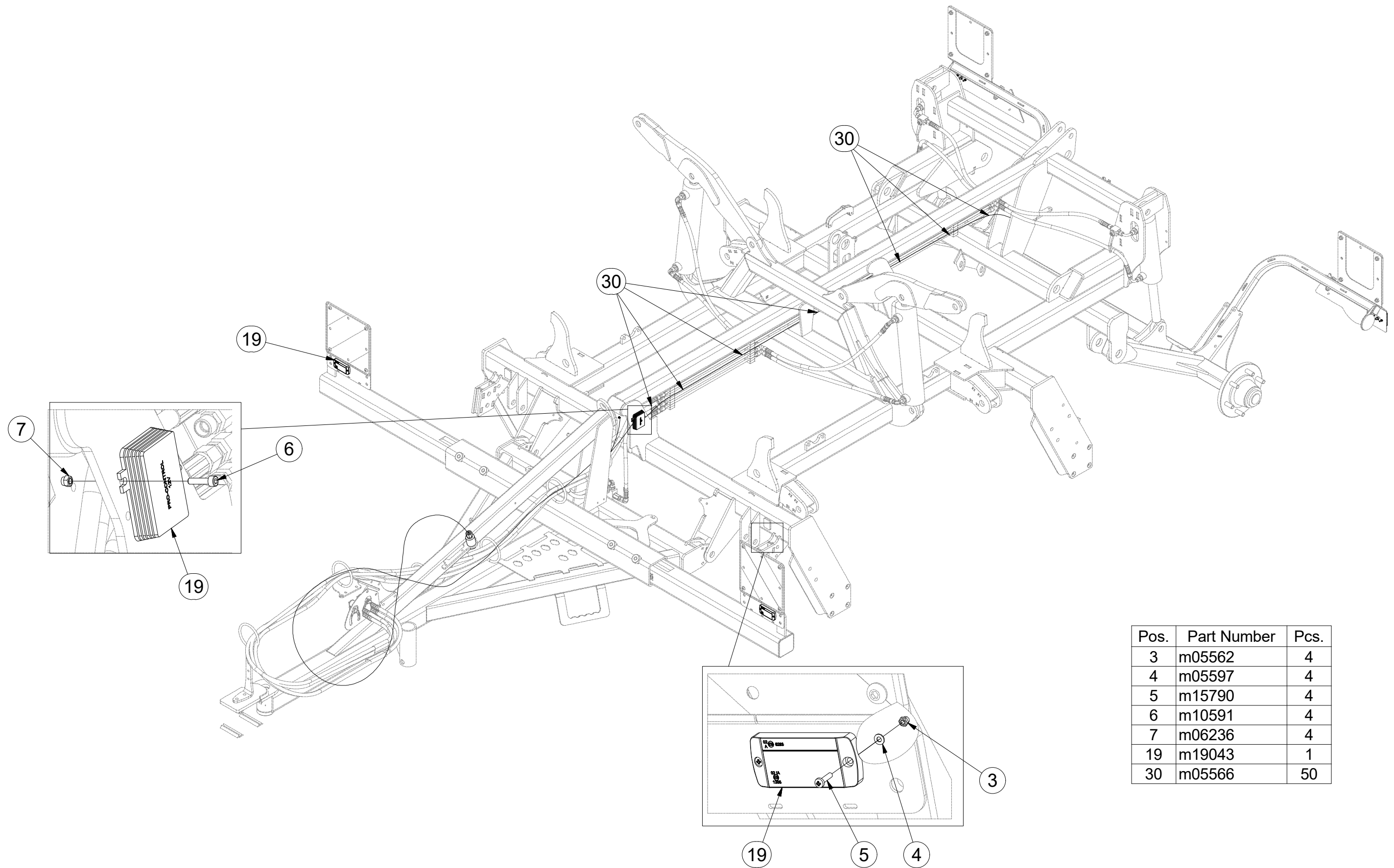

| Pos. | Part Number | Pcs. |
|------|-------------|------|
| 3 | m05562 | 4 |
| 4 | m05597 | 4 |
| 5 | m15790 | 4 |
| 6 | m10591 | 4 |
| 7 | m06236 | 4 |
| 19 | m19043 | 1 |
| 30 | m05566 | 50 |

Ⓒ SVĚTELNÁ SADA

Ⓓ LEUCHTENSATZ

Ⓕ KIT LUMINEUX

Ⓖ LIGHTING SET

Ⓡ ОСВЕТИТЕЛЬНЫЙ КОМПЛЕКТ

Ⓢ ZESTAW OŚWIETLENIA

Farmet

3012429

| Pos. | Part Number | Pcs. |
|------|-------------|------|
| 19 | m19043 | 1 |
| 17 | m05081 | 4 |
| 18 | m05595 | 4 |
| 30 | m05566 | 50 |

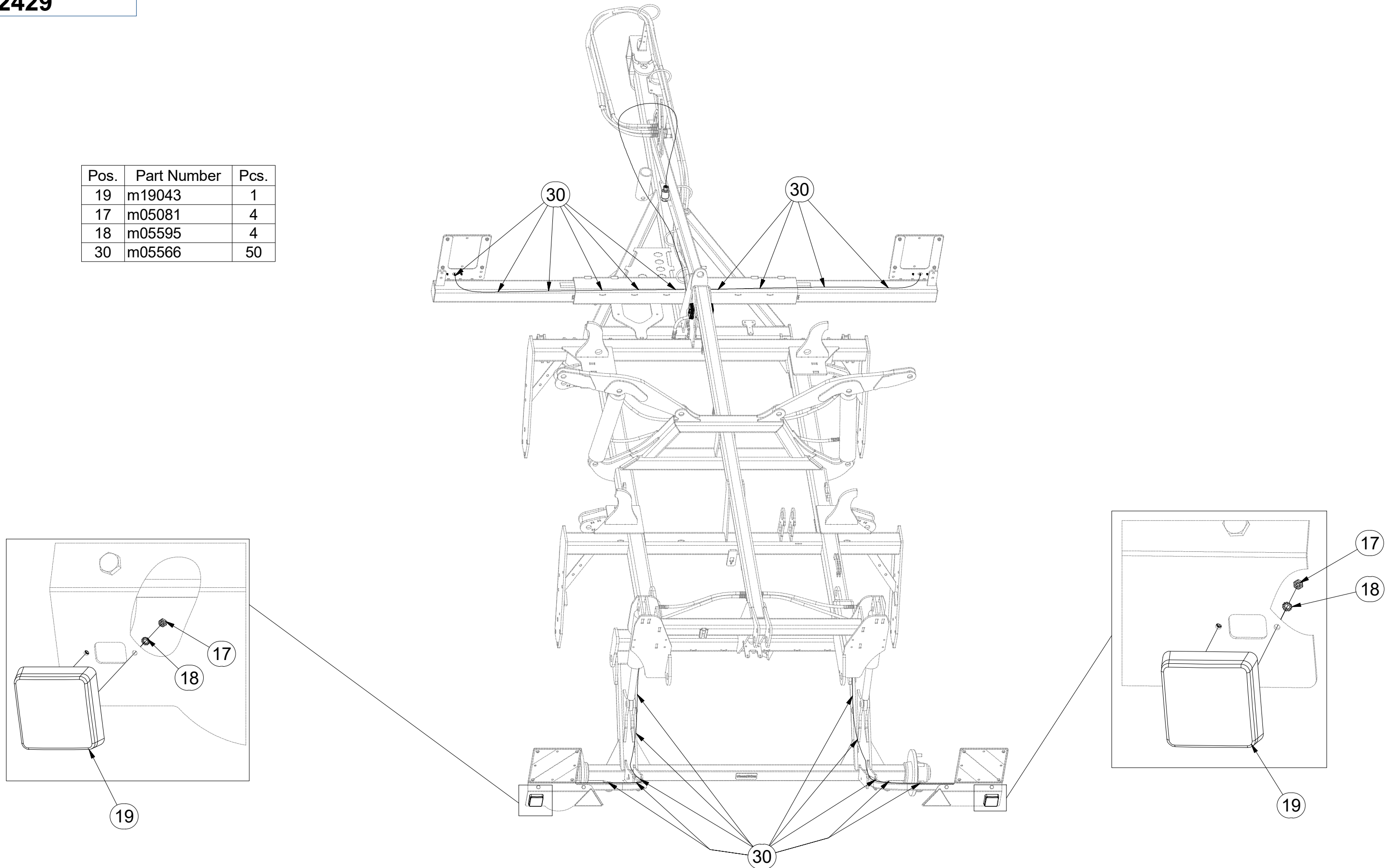

Ⓒ SVĚTELNÁ SADA

Ⓓ LEUCHTENSATZ

Ⓕ KIT LUMINEUX

m19043

Ⓒ LIGHTING SET

Ⓓ ОСВЕТИТЕЛЬНЫЙ КОМПЛЕКТ

Ⓕ ZESTAW OŚWIETLENIA

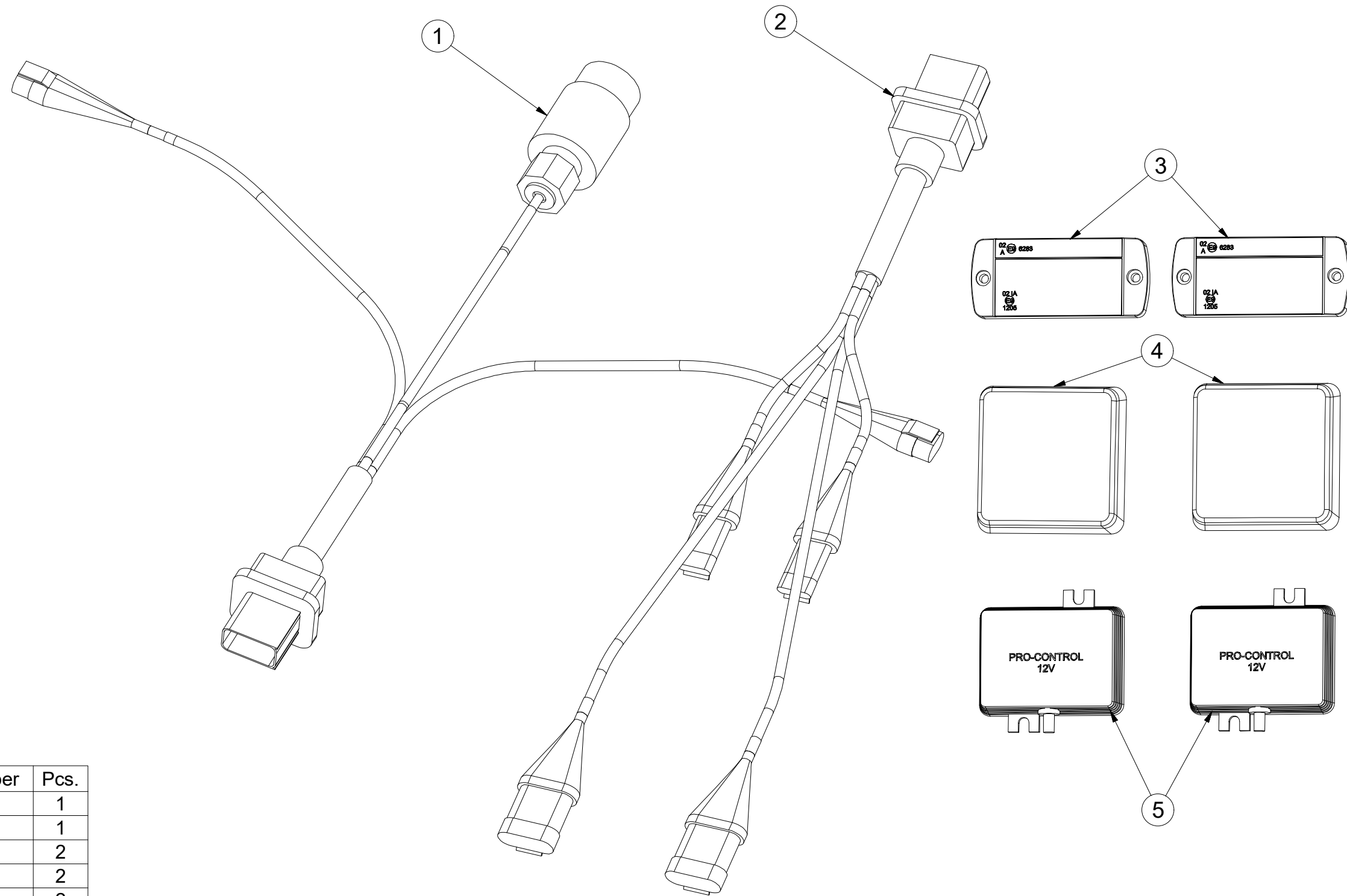

| Pos. | Part Number | Pcs. |
|------|-------------|------|
| 1 | m14779 | 1 |
| 2 | m14778 | 1 |
| 3 | m14776 | 2 |
| 5 | m14777 | 2 |
| 4 | m19044 | 2 |

- Ⓒ UTAHOVACÍ MOMENTY ŠROUBŮ
 Ⓓ ANZUGMOMENTE VON SCHRAUBEN
 Ⓕ COUPLES DE SERRAGE DES VIS

- Ⓖ SCREW TIGHTENING TORQUE
 Ⓔ МОМЕНТЫ ЗАЖАТИЯ БОЛТОВ
 Ⓗ MOMENTY DOKRĘCANIA ŚRUB



| P | | 5.8 | 8.8 | 10.9 | 12.9 |
|-----|------|------|------|-------|-------|
| D | R | Mu | Mu | Mu | Mu |
| mm | mm | Nm | Nm | Nm | Nm |
| M 6 | 1 | 6 | 9 | 13 | 15 |
| M 8 | 1,25 | 14 | 22 | 32 | 38 |
| M10 | 1,5 | 29 | 44 | 64 | 75 |
| M12 | 1,75 | 49 | 76 | 111 | 130 |
| M14 | 2 | 79 | 120 | 176 | 206 |
| M16 | 2 | 123 | 188 | 276 | 323 |
| M18 | 2,5 | 169 | 257 | 378 | 443 |
| M20 | 2,5 | 239 | 365 | 536 | 628 |
| M22 | 2,5 | 329 | 529 | 738 | 864 |
| M24 | 3 | 413 | 629 | 924 | 1082 |
| M27 | 3 | 613 | 934 | 1372 | 1606 |
| M30 | 3,5 | 832 | 1267 | 1862 | 2179 |
| M33 | 3,5 | 1130 | 1723 | 2530 | 2961 |
| M36 | 4 | 1451 | 2210 | 3246 | 3799 |
| M39 | 4 | 1885 | 2872 | 4217 | 4936 |
| M42 | 4,5 | 2322 | 3538 | 5196 | 6080 |
| M45 | 4,5 | 2909 | 4433 | 6511 | 7619 |
| M48 | 5 | 3513 | 5353 | 7862 | 9200 |
| M52 | 5 | 4524 | 6895 | 10126 | 11849 |
| M56 | 5,5 | 5636 | 8589 | 12614 | 14761 |

- Mu - Ⓒ UTAHOVACÍ MOMENT
 Ⓓ ANZUGMOMENT
 Ⓕ COUPLE DE SERRAGE
 D - Ⓒ JMENOVITÝ PRŮMĚR
 Ⓓ NENNDURCHMESSER
 Ⓕ DIAMETRE NOMINAL
 R - Ⓒ ROZTEČ ZÁVITU - STOUPÁNÍ
 Ⓓ GEWINDESTEIGUNG
 Ⓕ PAS DE FILET - PAS
 P - Ⓒ PEVNOST
 Ⓓ FESTIGKEIT
 Ⓕ RÉSISTANCE
 Ⓖ TIGHTENING TORQUE
 Ⓔ МОМЕНТ ЗАЖАТИЯ
 Ⓗ MOMENT DOKRĘCANIA
 Ⓖ NOMINAL DIAMETER
 Ⓔ НОМИНАЛЬНЫЙ ДИАМЕТР
 Ⓗ ŚREDNICA NOMINALNA
 Ⓖ SCREW PITCH – LEAD
 Ⓔ ШАГ РЕЗЬБЫ
 Ⓗ ROZSTAW GWINTU - SKOKI
 Ⓖ STRENGTH
 Ⓔ ПРОЧНОСТЬ
 Ⓗ WYTRZYMAŁOŚĆ

- Ⓒ Šroubové spoje utahujte dle vyznačeného utahovacího momentu v dokumentaci. Pokud není utahovací moment v dokumentaci vyznačen, utahujte dle obecné tabulky. Pokud je v dokumentaci definován spoj ze šroubu a matice o různých pevnostech, vždy utahujte na moment komponenty s nižší pevností.
- Ⓓ Ziehen Sie die Schraubverbindungen gemäß dem in der Dokumentation festgeschriebenen Anzugsmoments an. Sofern das Anzugsmoment nicht in der Dokumentation aufgeführt ist, ziehen Sie sie gemäß der allgemeinen Tabelle an. Wenn in der Dokumentation eine Verbindung von Schraube und Mutter mit verschiedenen Festigkeiten definiert ist, wird immer mit dem Moment des Bauteils mit der geringeren Festigkeit angezogen.
- Ⓕ Serrez les raccords à vis selon le couple de serrage indiqué dans les documents. Si le couple de serrage n'est pas indiqué dans les documents, serrez selon le tableau général. Si les documents définissent un assemblage par boulon de diverses résistances, serrez toujours au moment de la composante avec résistance inférieure.
- Ⓖ Tighten the screw joints according to the tightening torque stated in the documentation. If the tightening torque is not stated in the documentation, tighten according to the general table. If there is a joint with a screw and a nut at different strengths in the documentation, always tighten to the torque of the component with lower strength.
- Ⓔ Резьбовые соединения зажимайте с установленным в документации моментом зажатия. Если в документации не указан момент зажатия, то зажимайте по действующей в общем таблице. Если в документации установлено соединение из болта и гайки различной прочности, всегда зажимайте с моментом для компонента с меньшей прочностью.
- Ⓗ Połączenia śrubowe należy dokręcać zgodni z momentem obrotowym w dokumentacji. Jeśli w dokumentacji nie ma podanego momentu obrotowego, należy dokręcać zgodnie z ogólną tabelą. Jeśli w dokumentacji zdefiniowane jest połączenie ze śrubą i nakrętką o różnych wytrzymałościach, zawsze należy dokręcać zachowując moment dokręcania komponentu z niższą wytrzymałością.

- Ⓒ UTAHOVACÍ MOMENTY ŠROUBŮ
 Ⓓ ANZUGMOMENTE VON SCHRAUBEN
 Ⓕ COUPLES DE SERRAGE DES VIS

- Ⓖ SCREW TIGHTENING TORQUE
 Ⓔ МОМЕНТЫ ЗАЖАТИЯ БОЛТОВ
 Ⓟ MOMENTY DOKRĘCANIA ŚRUB



- Ⓒ **OBECNÝ PŘEDPIS UTAHOVÁNÍ ZAJIŠTĚNÍ ČEPOVÝCH SPOJŮ:**
 Ⓓ **ALLGEMEINE VORSCHRIFT FÜR DAS ANZIEHEN VON BOLZENVERBINDUNGEN:**
 Ⓕ **CONSIGNE GENERALE POUR LE SERRAGE DES ARTICULATIONS CYLINDRIQUES:**
 Ⓖ **GENERAL INSTRUCTION FOR TIGHTENING THE SECURING OF PIN JOINTS:**
 Ⓔ **ОБЩЕЕ ОПИСАНИЕ ЗАЖАТИЯ ПРЕДОХРАНЕНИЯ СОЕДИНЕНИЙ ПАЛЬЦАМИ:**
 Ⓟ **OGÓLNE ZASADY DOKRĘCANIA ZABEZPIECZENIA POŁĄCZEŃ CZOPEM:**



| X | M |
|--------------|---------|
| M8, M10, M12 | 09-15Nm |
| M14 | 15-25Nm |

- | | | | |
|------------------------|------------------|-------------------------|-------------------------|
| X - Ⓒ ROZMĚR ŠROUBU | Ⓖ BOLT DIMENSION | M - Ⓒ ORIENTAČNÍ MOMENT | Ⓖ ORIENTATION TORQUE |
| Ⓓ SCHRAUBENGRÖSSE | Ⓔ РАЗМЕР БОЛТА | Ⓓ ANZUGSMOMENT | Ⓔ ОПИЕНТАЦИОННЫЙ МОМЕНТ |
| Ⓕ DIMENSIONS DE LA VIS | Ⓟ ROZMIAR ŚRUBY | Ⓕ COUPLE D'ORIENTATION | Ⓟ ORIENTACYJNY MOMENT |

- Ⓒ Tyto spoje není nutné ověřovat kontrolou momentovým klíčem = stačí vizuálně kontrolovat sešroubování.
 Ⓓ Diese Verbindungen müssen nicht mit einem Drehmomentschlüssel überprüft werden = es genügt, die Verschraubung visuell zu kontrollieren.
 Ⓕ Il n'est pas nécessaire de contrôler le serrage à l'aide d'une clé dynamométrique = un contrôle visuel de l'assemblage suffit.
 Ⓖ These joints do not have to be verified by checking with a torque wrench = visual inspection of bolting is sufficient.
 Ⓔ Эти соединения не нужно контролировать динамометрическим ключом = достаточно визуально проверять прикручивание.
 Ⓟ Nie trzeba sprawdzać tych połączeń kluczem dynamometrycznym = wystarczy wizualnie skontrolować dokręcenie.