

*The effective technology*

**Farmet**<sup>®</sup>

ⒸZ KATALOG NÁHRADNÍCH DÍLŮ ⒸB CATALOGUE OF SPARE PARTS ⒸD ERSATZTEILLISTE  
ⒸRU КАТАЛОГ ЗАПАСНЫХ ЧАСТЕЙ ⒸF CATALOGUE DES PIÈCES DE RECHANGE ⒸPL KATALOG CZĘŚCI ZAMIENNYCH

# **KOMPAKTOMAT K600PS**

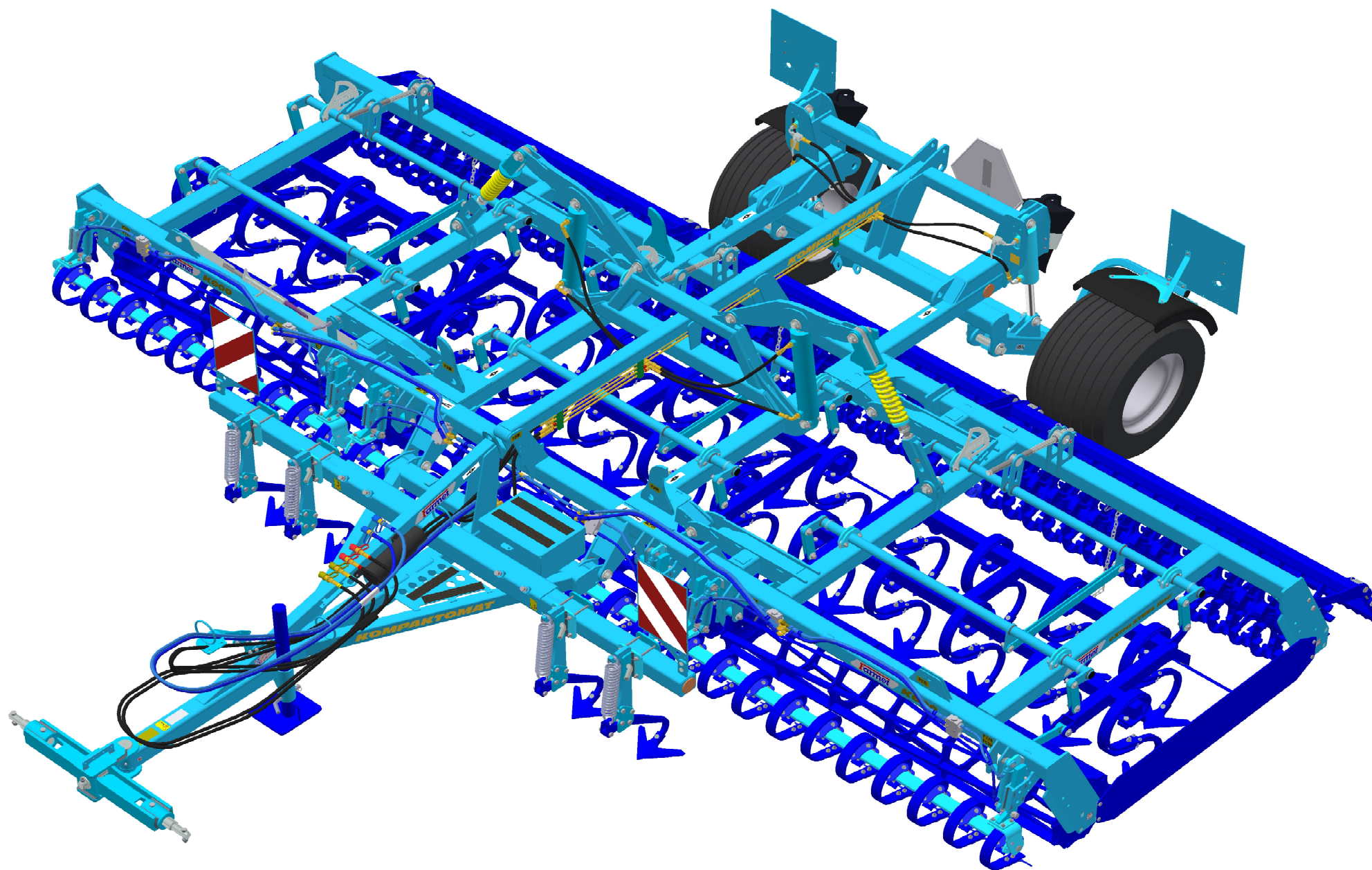

ⒸZ Platnost pro vrcholové | výrobní číslo stroje ⒸB Validity for the top | serial number of the machine  
ⒸD Gültigkeit für die Haupt- | Herstellungsnummer der Maschine ⒸRU Действительно для главного | заводского номера машины  
ⒸF Validité du numéro de référence | de série de la machine ⒸPL Obowiązuje dla numeru głównego | seryjnego maszyny

**9333017 | 2016/1152**

**Farmet a. s.**  
Jiřinková 276  
552 03 Česká Skalice, CZ

telefon: +420 491 450 111  
fax: +420 491 450 136  
GSM: +420 774 715 738

IČ: 46504931  
DIČ: CZ46504931

web: [www.farmet.cz](http://www.farmet.cz)  
e-mail: [farmet@farmet.cz](mailto:farmet@farmet.cz)

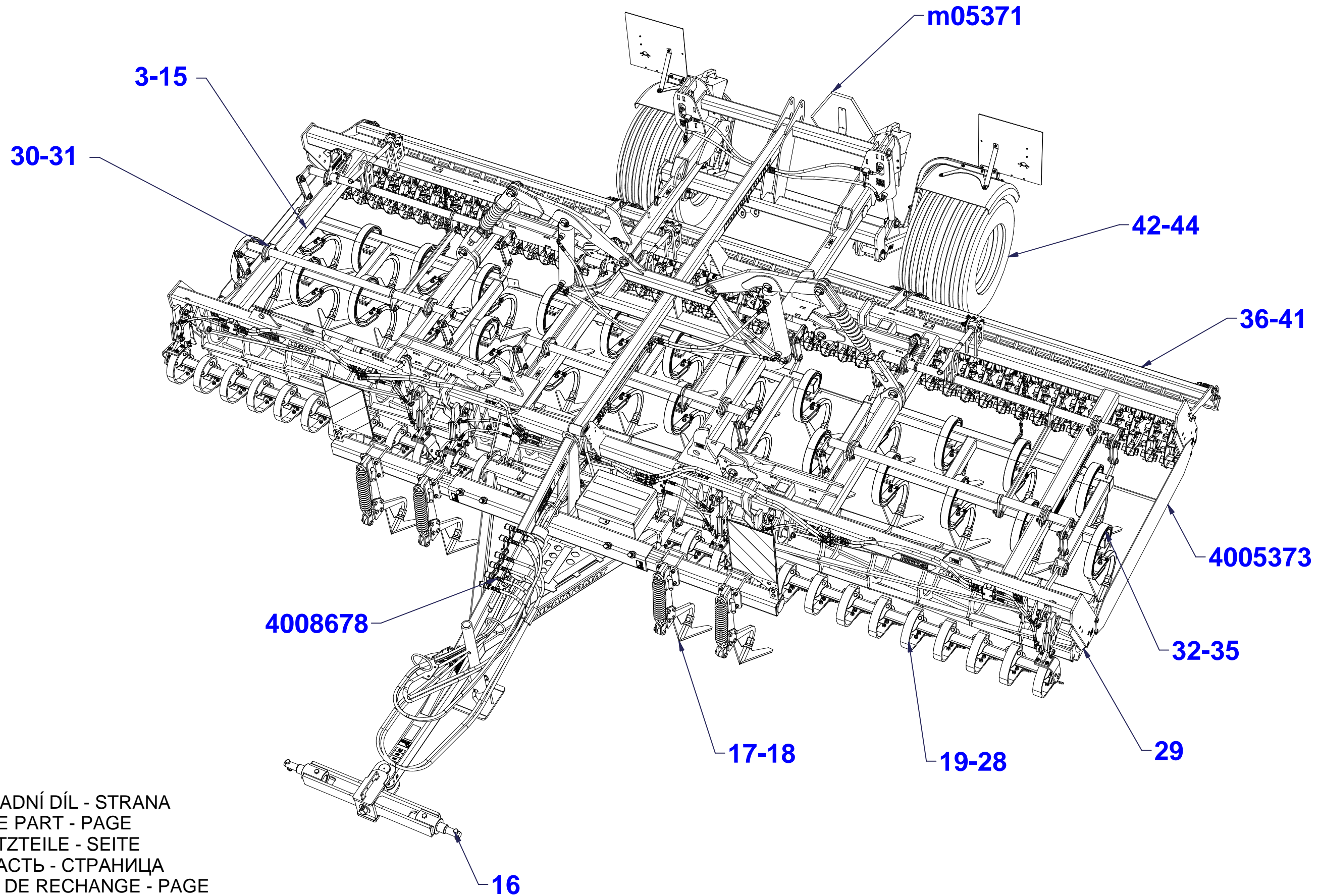

☉ POLOTOVAR STROJE

☉ MASCHINEN-HALBFABRIKAT

☉ MACHINE - SEMI-PRODUIT

☉ SEMIFINISHED MACHINE

☉ ПОЛУФАБРИКАТ МАШИНЫ

☉ PÓLFABRYKAT MASZYNY



**3007965**

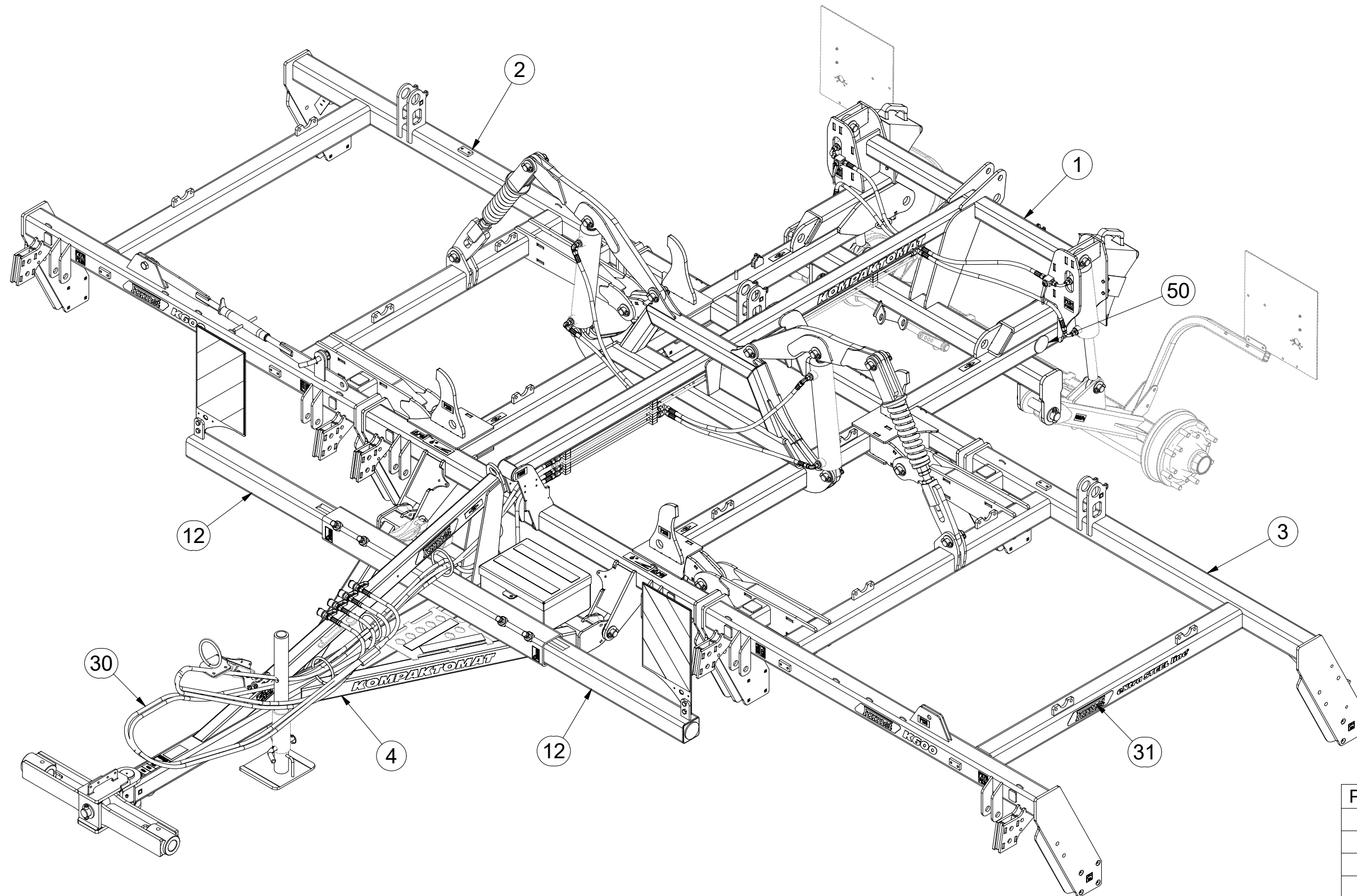

Pos.	Part Number	Pcs.
1	6000462	1
2	6000463	1
3	6000464	1
4	1000094	1
12	4004460	2
30	m11151	1
31	m11149	1
50	m02579	4

☉ POLOTOVAR STROJE

☉ MASCHINEN-HALBFABRIKAT

☉ MACHINE - SEMI-PRODUIT

☉ SEMIFINISHED MACHINE

☉ ПОЛУФАБРИКАТ МАШИНЫ

☉ PÓLFABRYKAT MASZYN



### 3007965

Pos.	Part Number	Pcs.	Pos.	Part Number	Pcs.
4	1000094	1	141	m03866	1
9	3003789	1	143	4013139	6
10	3003787	1	144	m14029	40
11	4003744	2	160	m10451	1
12	4004460	2	165	m03959	1
16	8000647-40207	1	170	m11099	18

	
M8 (8.8) - 25Nm	
M10 (8.8) - 50Nm	
M12 (8.8) - 87Nm	
M16 (8.8) - 210Nm	
KM6 - 8Nm	

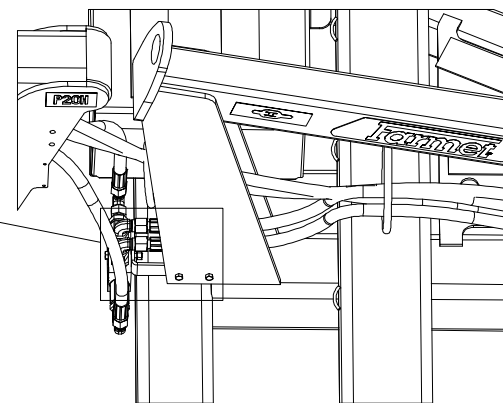
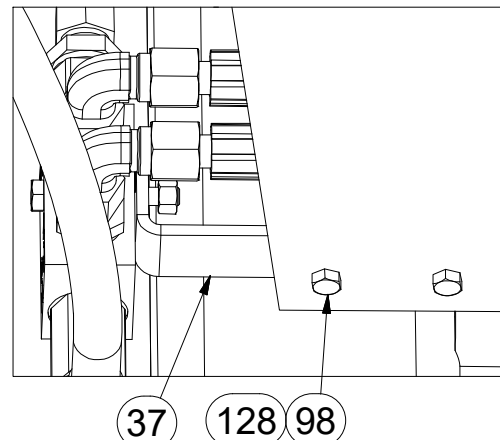
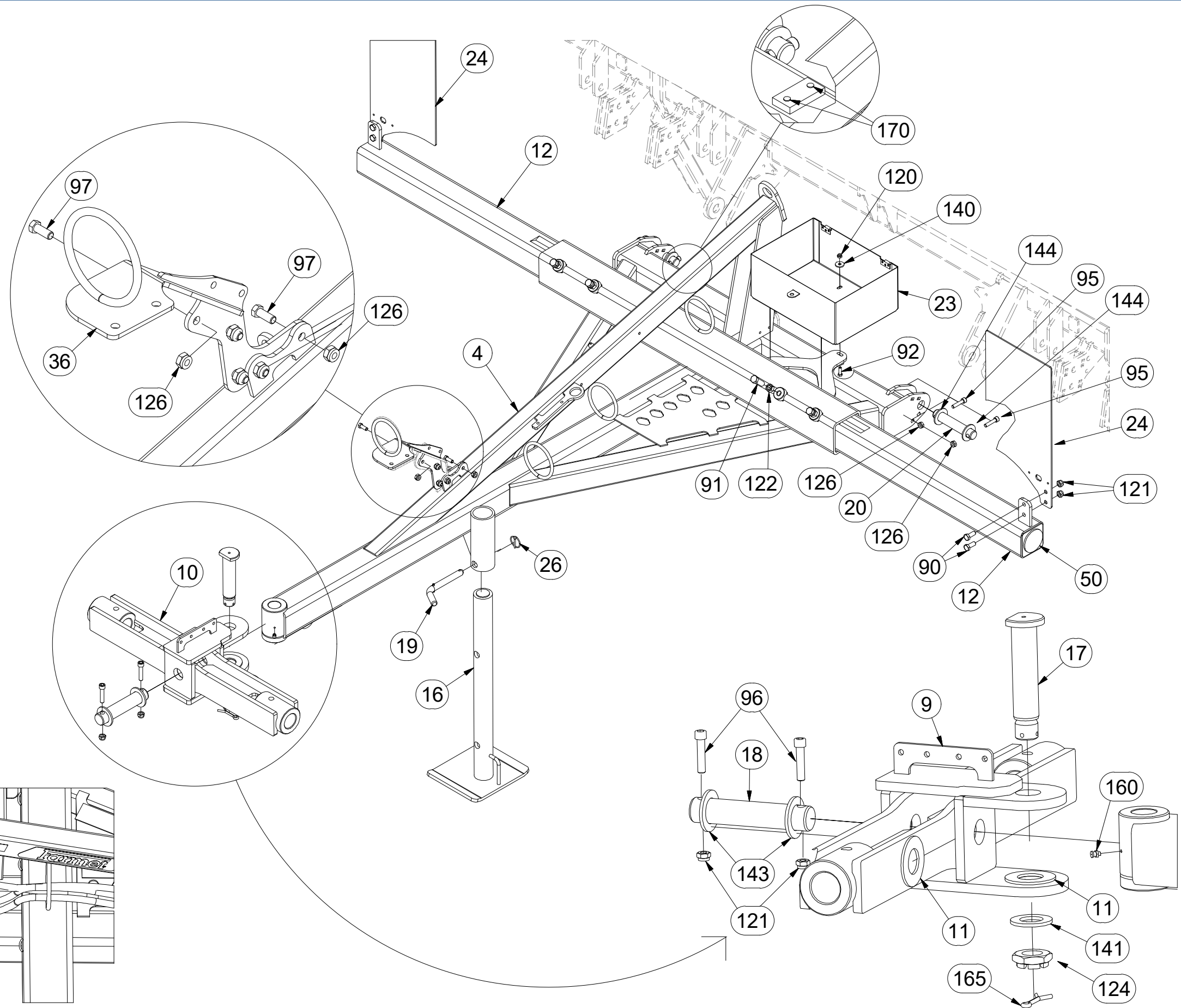

☉ POLOTOVAR STROJE

☉ MASCHINEN-HALBFABRIKAT

☉ MACHINE - SEMI-PRODUIT

☉ SEMIFINISHED MACHINE

☉ ПОЛУФАБРИКАТ МАШИНЫ

☉ PÓLFABRYKAT MASZYNY



**3007965**

Pos.	Part Number	Pcs.	Pos.	Part Number	Pcs.
5	3002837	2	33	4007640	4
6	4005363	2	34	4007641	4
7	4005366	2	93	m04241	1
13	9000248	2	95	m14143	40
15	4003966	1	123	m05648	1
21	4008234	6	126	m03775	45
22	4014569	2	127	m04043	2
25	4012011	1	144	m14029	40
26	m10454	2	170	m11099	18
32	4007584	2			



M20 (8.8) - 411Nm
M30 (8.8) - 1421Nm
M10 (8.8) - 50Nm

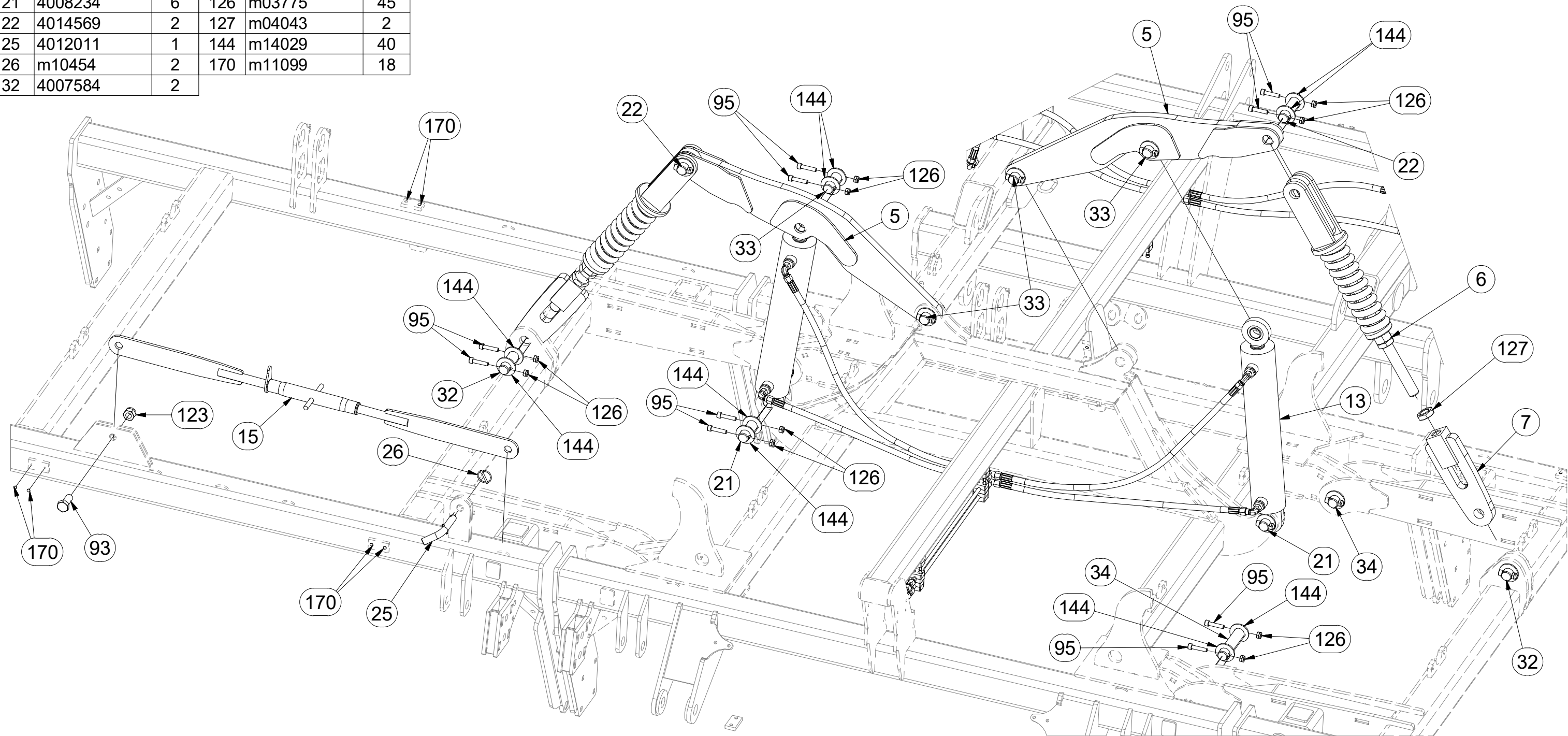

Ⓒ POLOTOVAR STROJE

Ⓓ MASCHINEN-HALBFABRIKAT

Ⓕ MACHINE - SEMI-PRODUIT

Ⓖ SEMIFINISHED MACHINE

Ⓡ ПОЛУФАБРИКАТ МАШИНЫ

Ⓟ PÓLFABRYKAT MASZYNY



**3007965**

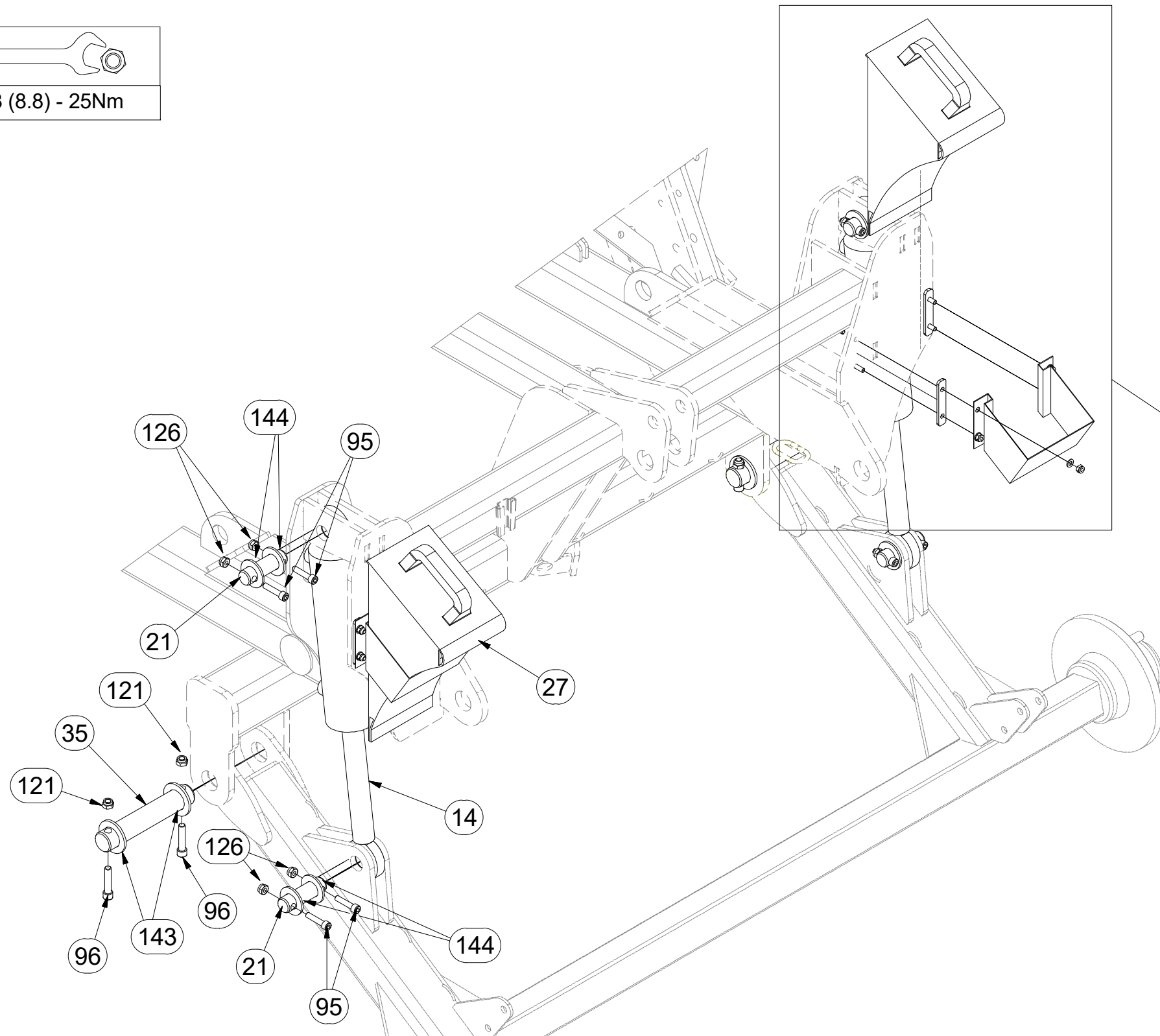
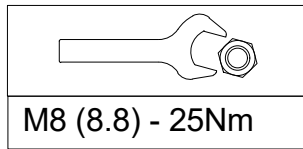

Pos.	Part Number	Pcs.	Pos.	Part Number	Pcs.
14	9000247	2	96	m14008	6
21	4008234	6	120	m04503	11
27	m16186	2	121	m04301	10
28	m12572	2	126	m03775	45
29	4012712	4	142	m01203	8
35	4010875	2	143	4013139	6
94	m04791	8	144	m14029	40
95	m14143	40			

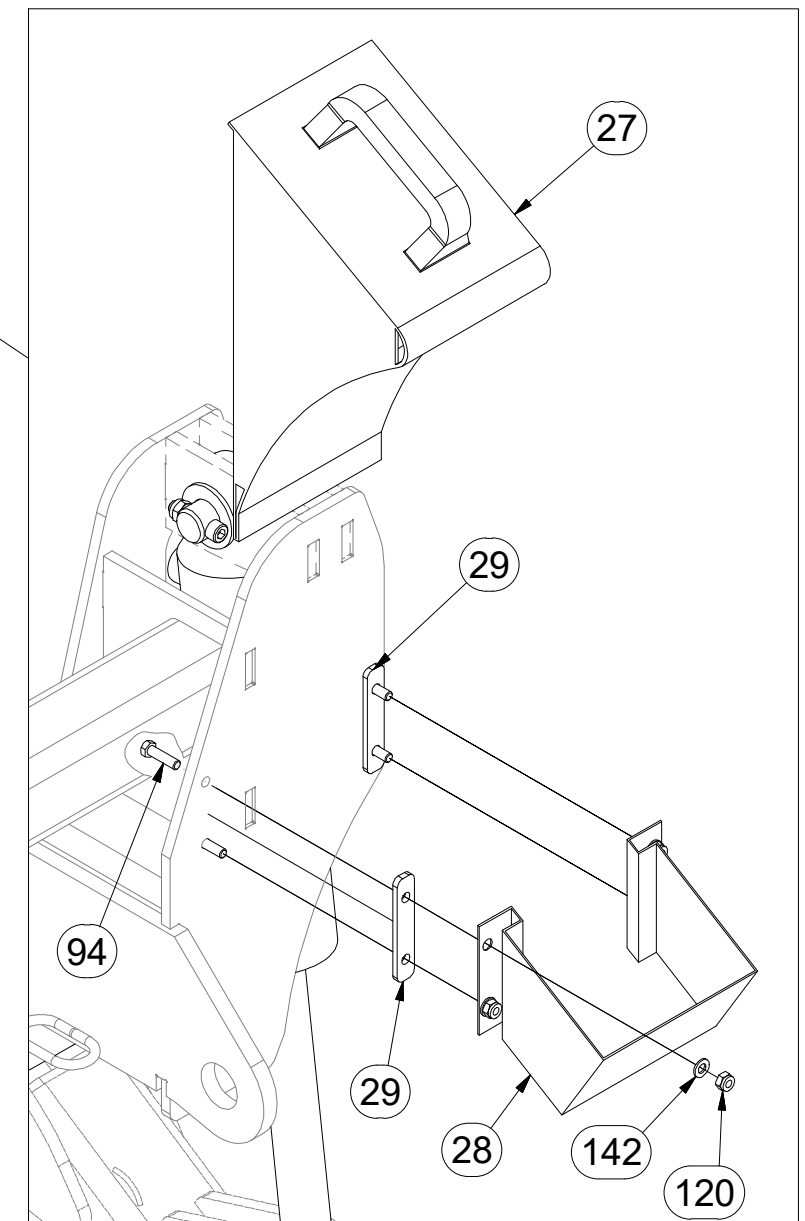

ⒸZ HYDRAULIKA STROJE

Ⓓ HYDRAULIK DER MASCHINE

Ⓕ HYDRAULIQUE DE LA MACHINE

ⒼB MACHINE HYDRAULICS

Ⓔ RU ГИДРАВЛИКА МАШИНЫ

ⒼL HYDRAULIKA MASZYN



**m11151**



M6 (8.8) - 10Nm

HYDRAULIC COMPONENTS:  
 M16 x 1,5 - 60Nm  
 M22 x 1,5 - 140Nm  
 G 3/8 - 95 Nm

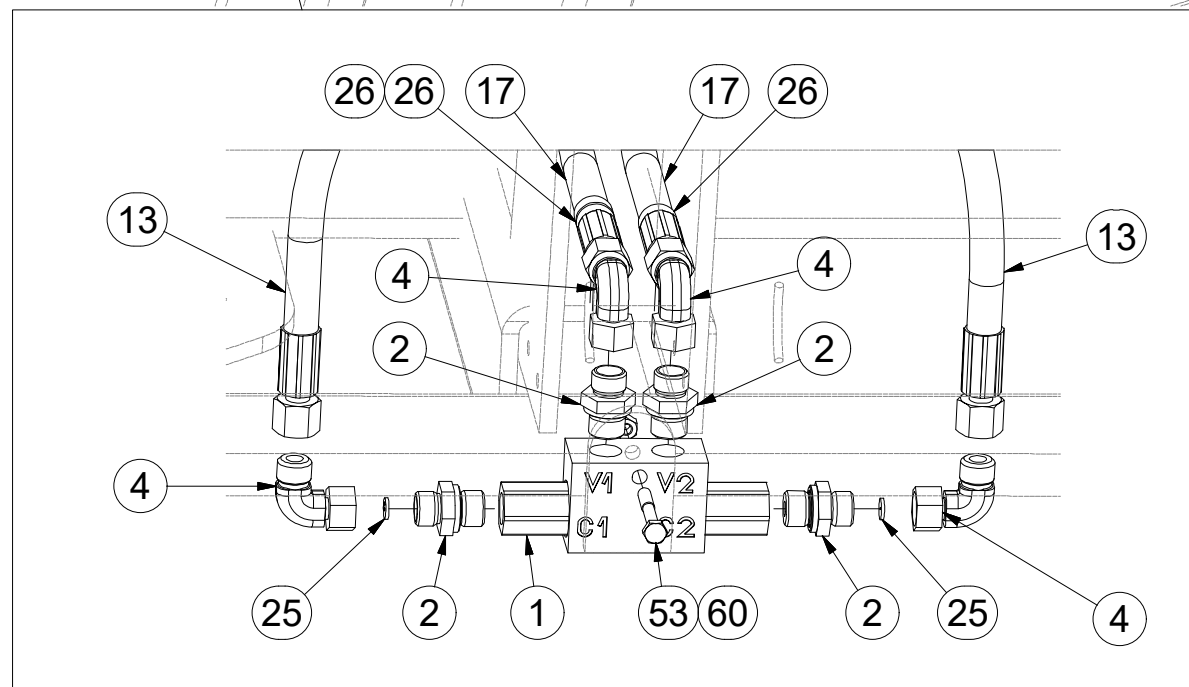
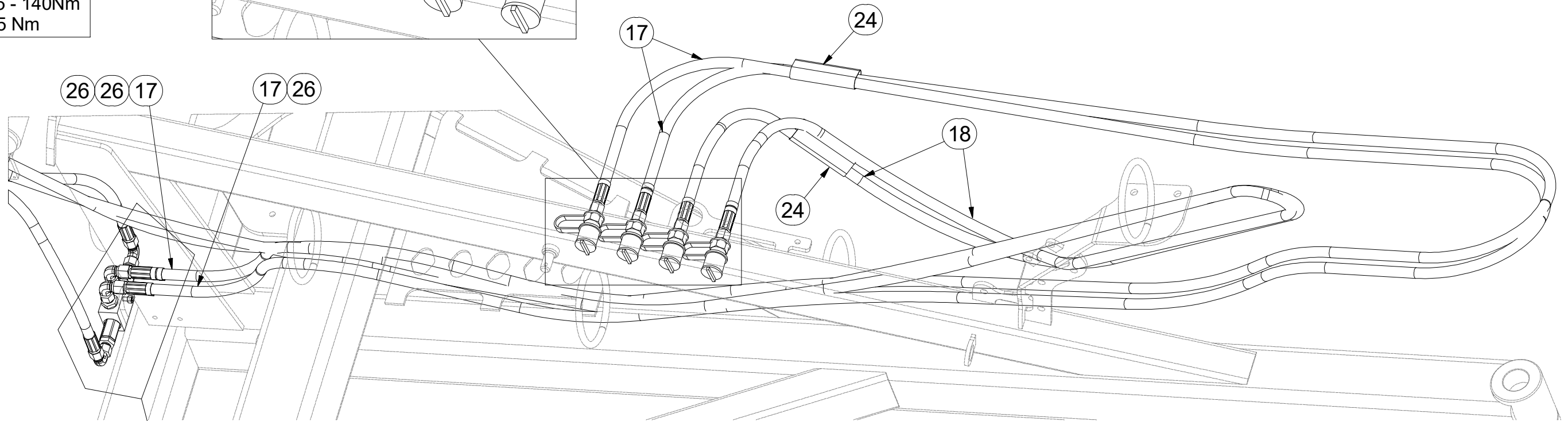
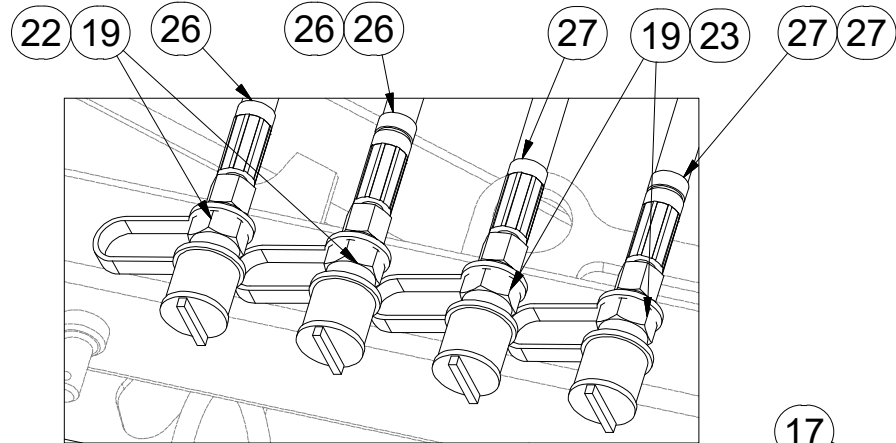

Pos.	Part Number	Pcs.
1	m06673	1
2	m06528	4
4	m06803	8
13	m03713	4
17	m04087	2
18	m09431	2
19	m03849	4
22	m04022	2
23	m04023	2
24	m11183	2
25	m10780	2
26	m11294	12
27	m11289	9
53	m05561	1
60	m05560	1

☉ HYDRAULIKA STROJE

☉ HYDRAULIK DER MASCHINE

☉ HYDRAULIQUE DE LA MACHINE

☉ MACHINE HYDRAULICS

☉ ГИДРАВЛИКА МАШИНЫ

☉ HYDRAULIKA MASZYNY



# m11151

Pos.	Part Number	Pcs.
4	m06803	8
5	m04803	2
6	m03975	2
7	m04009	10
8	m03889	4
9	m09934	8
12	m03213	4
13	m03713	4
15	m07909	2
16	m07646	2
18	m09431	2
26	m11294	12
27	m11289	9
50	m03704	4
52	m04021	6

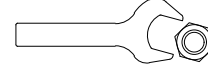

M6 (8.8) - 10Nm  
 HYDRAULIC COMPONENTS:  
 M16 x 1,5 - 60Nm  
 M22 x 1,5 - 140Nm  
 G 3/8 - 95 Nm

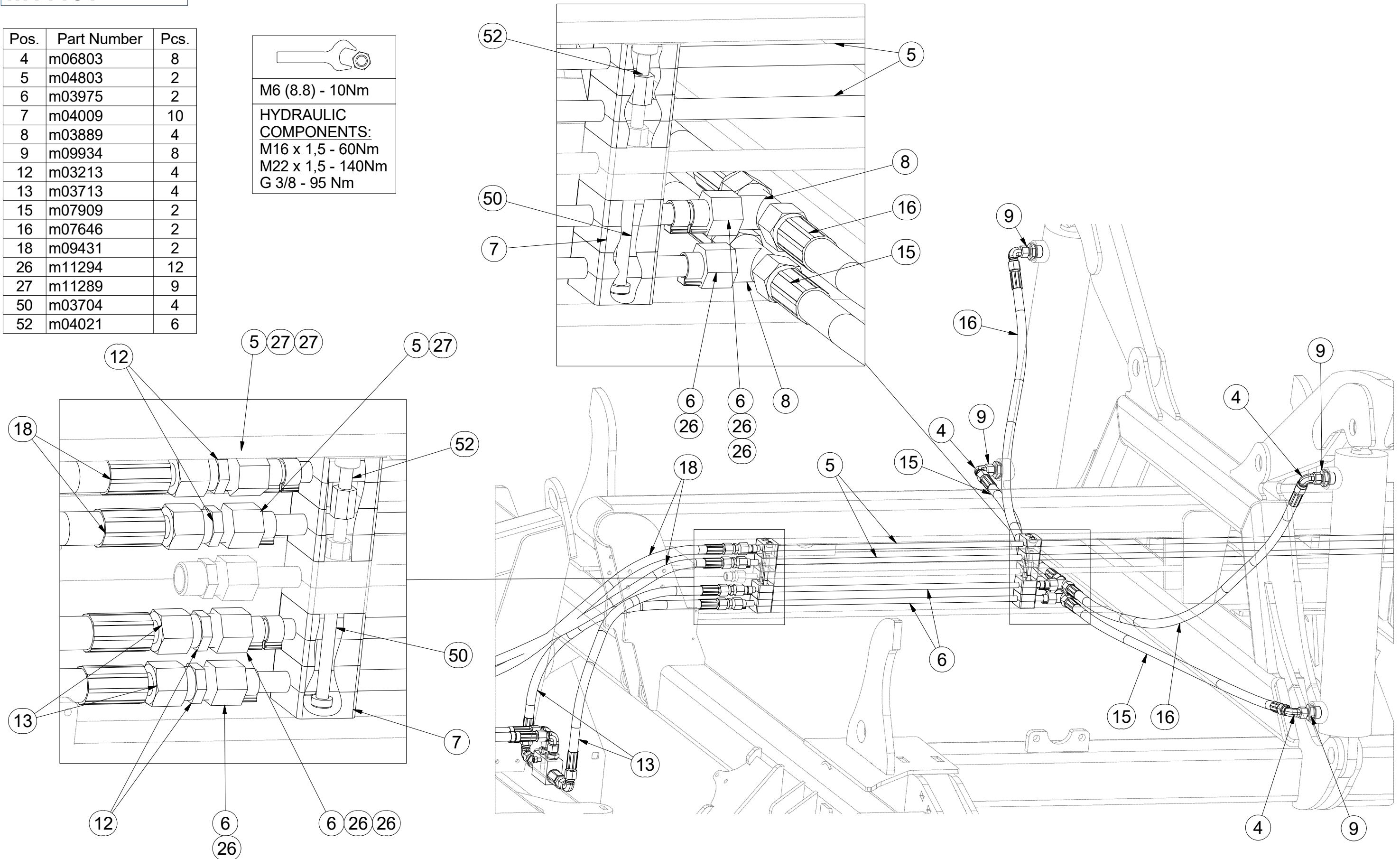



ⒸZ HYDRAULIKA STROJE

Ⓓ HYDRAULIK DER MASCHINE

Ⓕ HYDRAULIQUE DE LA MACHINE

ⒸB MACHINE HYDRAULICS

ⒸR ГИДРАВЛИКА МАШИНЫ

ⒸL HYDRAULIKA MASZYNY



**m11151**

M6 (8.8) - 10Nm
<b>HYDRAULIC COMPONENTS:</b>
M16 x 1,5 - 60Nm
M22 x 1,5 - 140Nm
G 3/8 - 95 Nm

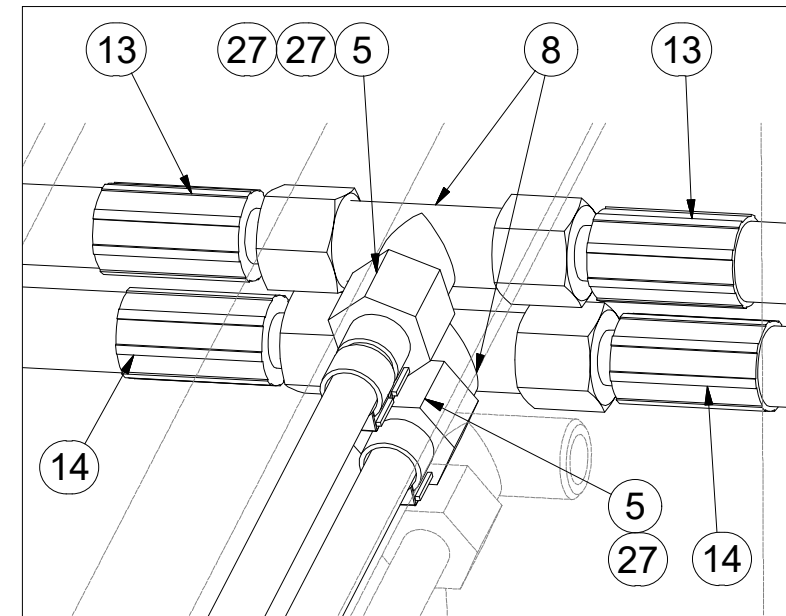
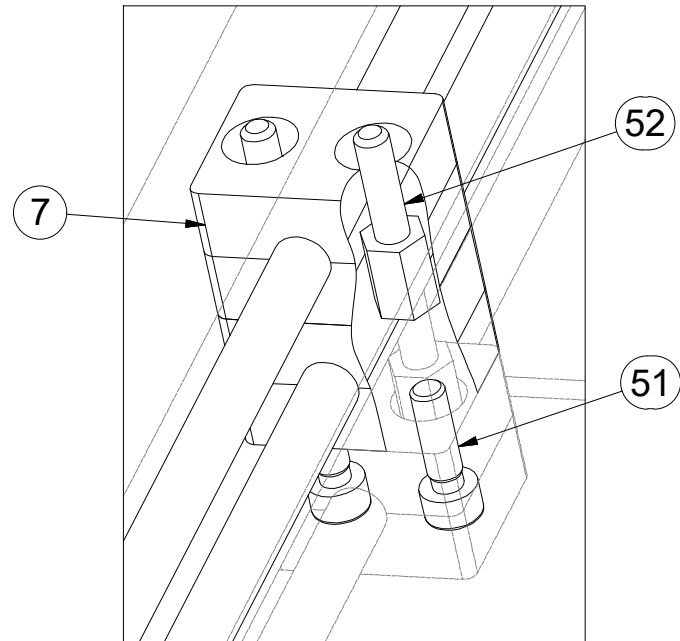

Pos.	Part Number	Pcs.
3	m04024	2
5	m04803	2
7	m04009	10
8	m03889	4
9	m09934	8
10	m04621	2
11	m04623	2
13	m03713	4
14	m04033	2
27	m11289	9
51	m04346	2
52	m04021	6

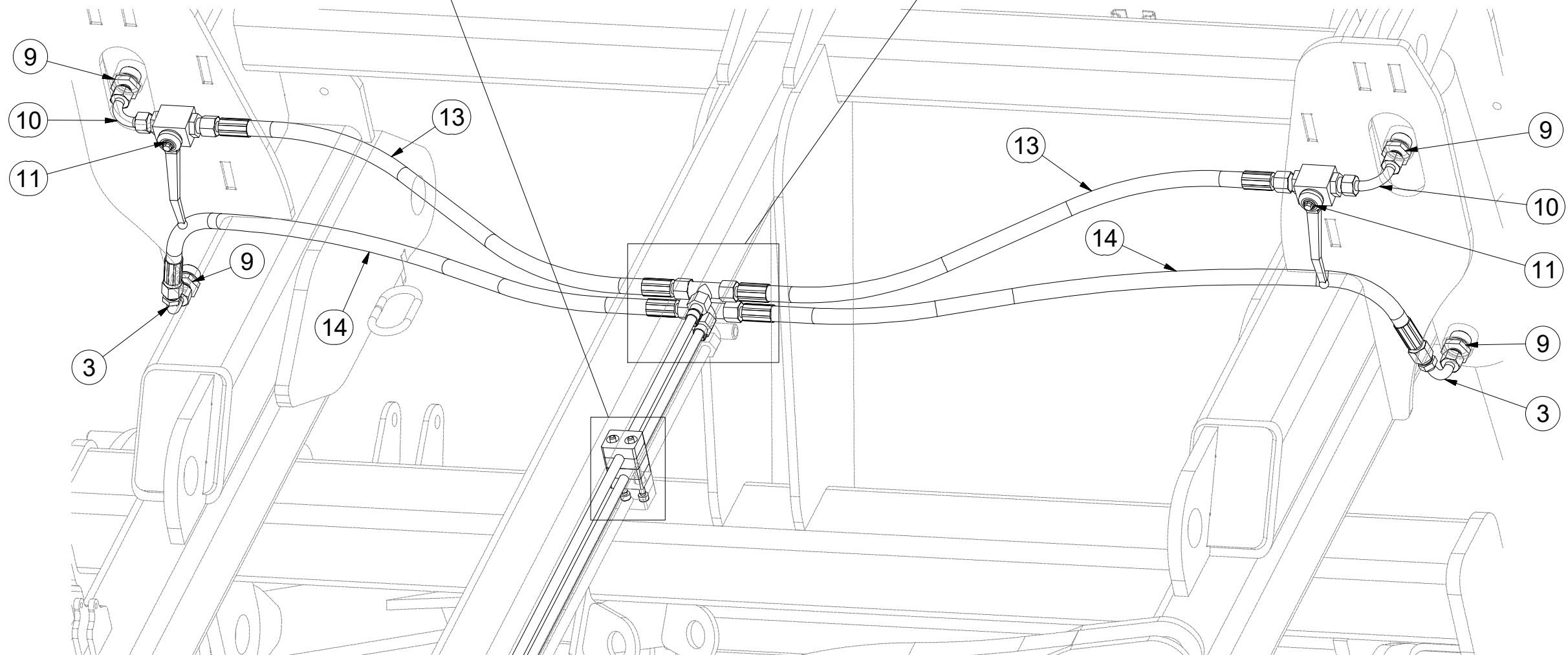

☉ SAMOLEPKY STROJE

☉ AUFKLEBER MASCHINEN

☉ VOITURE MACHINES

☉ STICKERS MACHINES

☉ СТИКЕРЫ МАШИНЫ

☉ NAKLEJKI MASZYNY



**m11149**

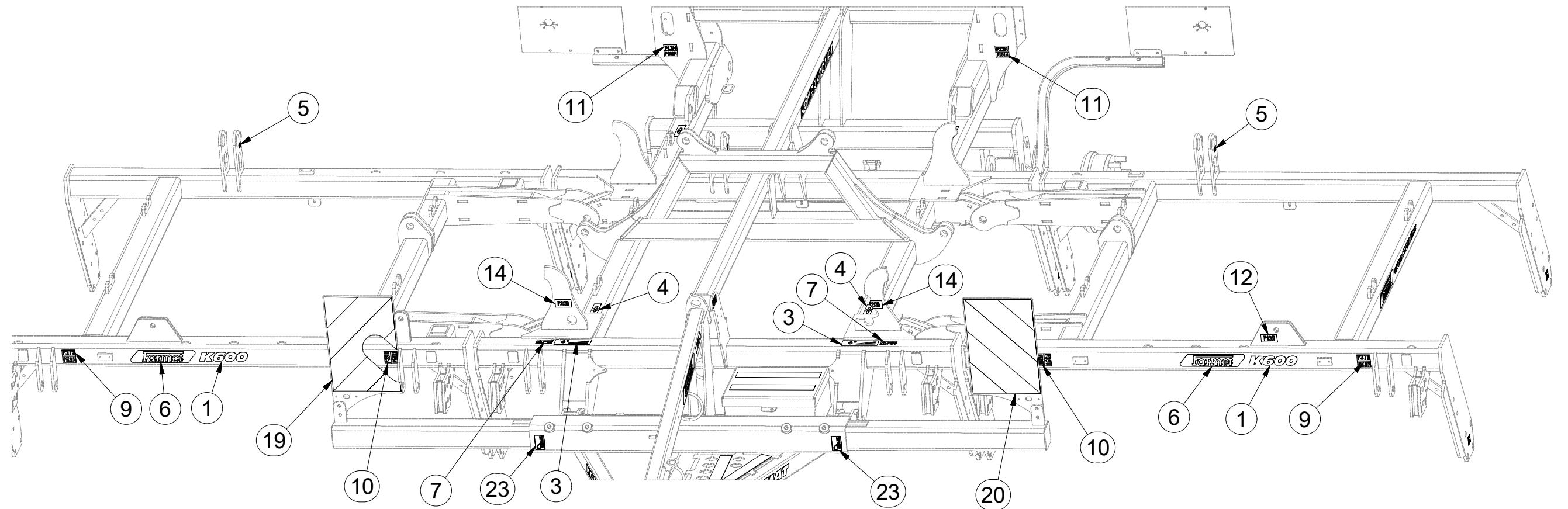

Pos.	Part Number	Pcs.
1	m07693	4
2	m07688	4
3	m03314	2
4	m03316	6
5	m03320	4
6	m13116	8
7	m04359	3
8	m11295	1
9	m11297	4
10	m11296	4
11	m11299	2
12	m04363	1
13	m11291	1
14	m04368	6
19	m12619	1
20	m12620	1
23	m10180	3
25	m11146	2
26	m11147	2
28	m13708	3

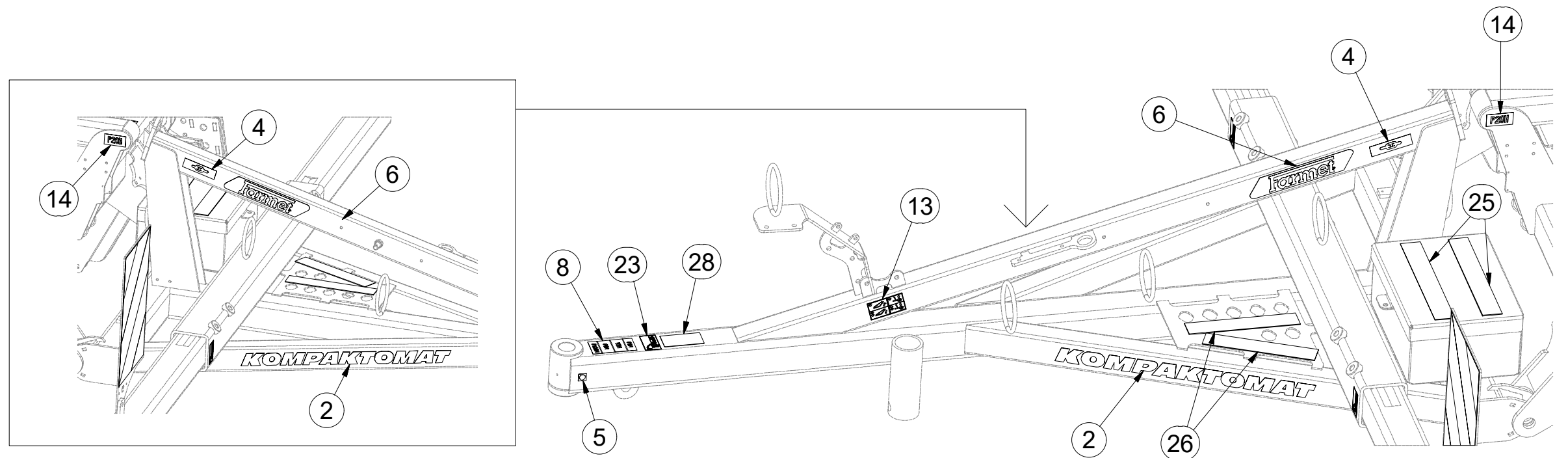

☉ SAMOLEPKY STROJE

☉ AUFKLEBER MASCHINEN

☉ VOITURE MACHINES

☉ STICKERS MACHINES

☉ СТИКЕРЫ МАШИНЫ

☉ NAKLEJKI MASZYNY



**m11149**

Pos.	Part Number	Pcs.	Pos.	Part Number	Pcs.
1	m07693	4	14	m04368	6
2	m07688	4	16	m04406	1
4	m03316	6	17	m04887	2
5	m03320	4	18	m12401	2
6	m13116	8	22	m09655	12
7	m04359	3	24	m10353	2
9	m11297	4	27	m13401	1
10	m11296	4	28	m13708	3

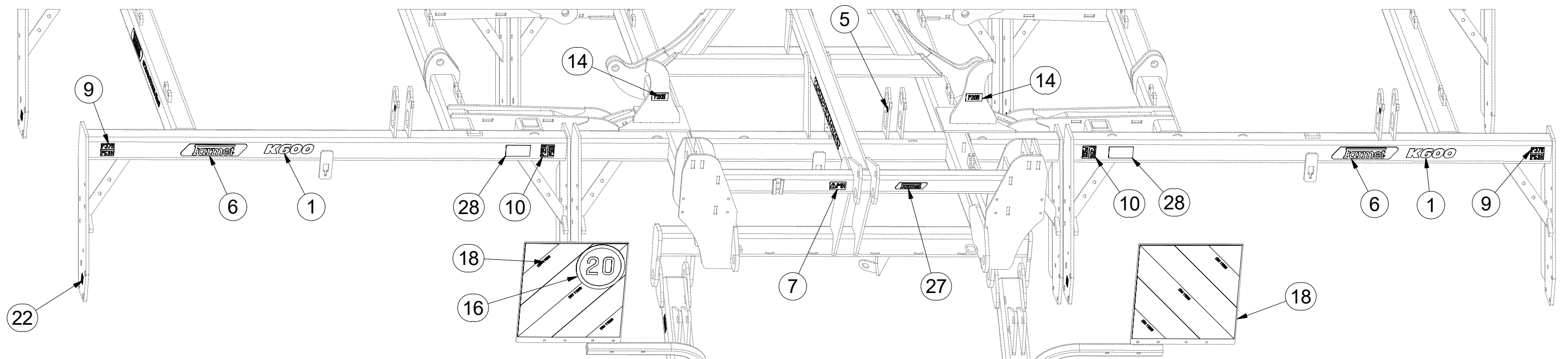
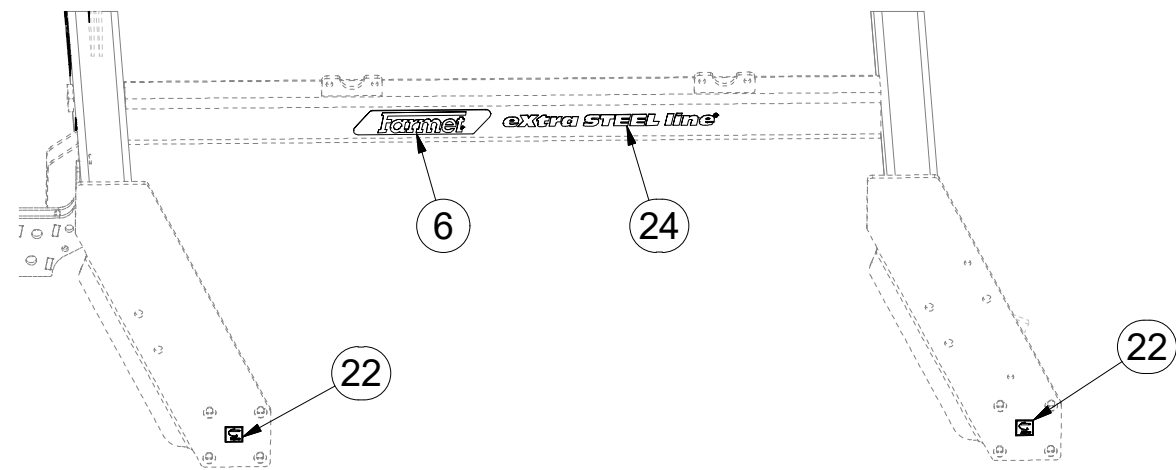
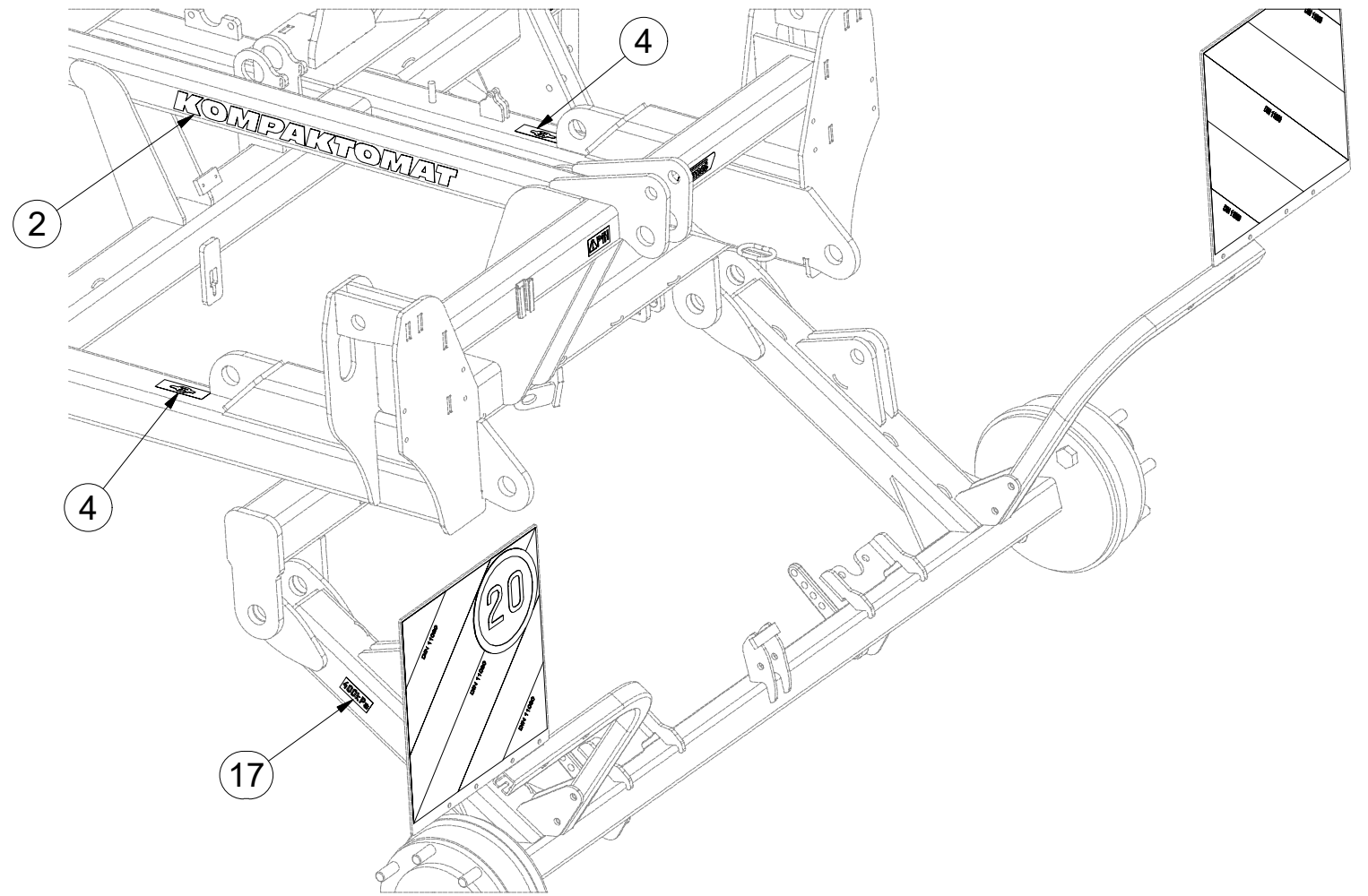

Ⓒ SADA

Ⓓ SATZ

Ⓕ KIT

**4018541**

Ⓖ SET

Ⓡ КОМПЛЕКТ

Ⓟ ZESTAW

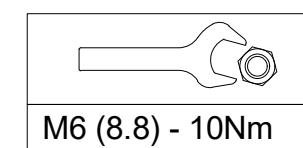
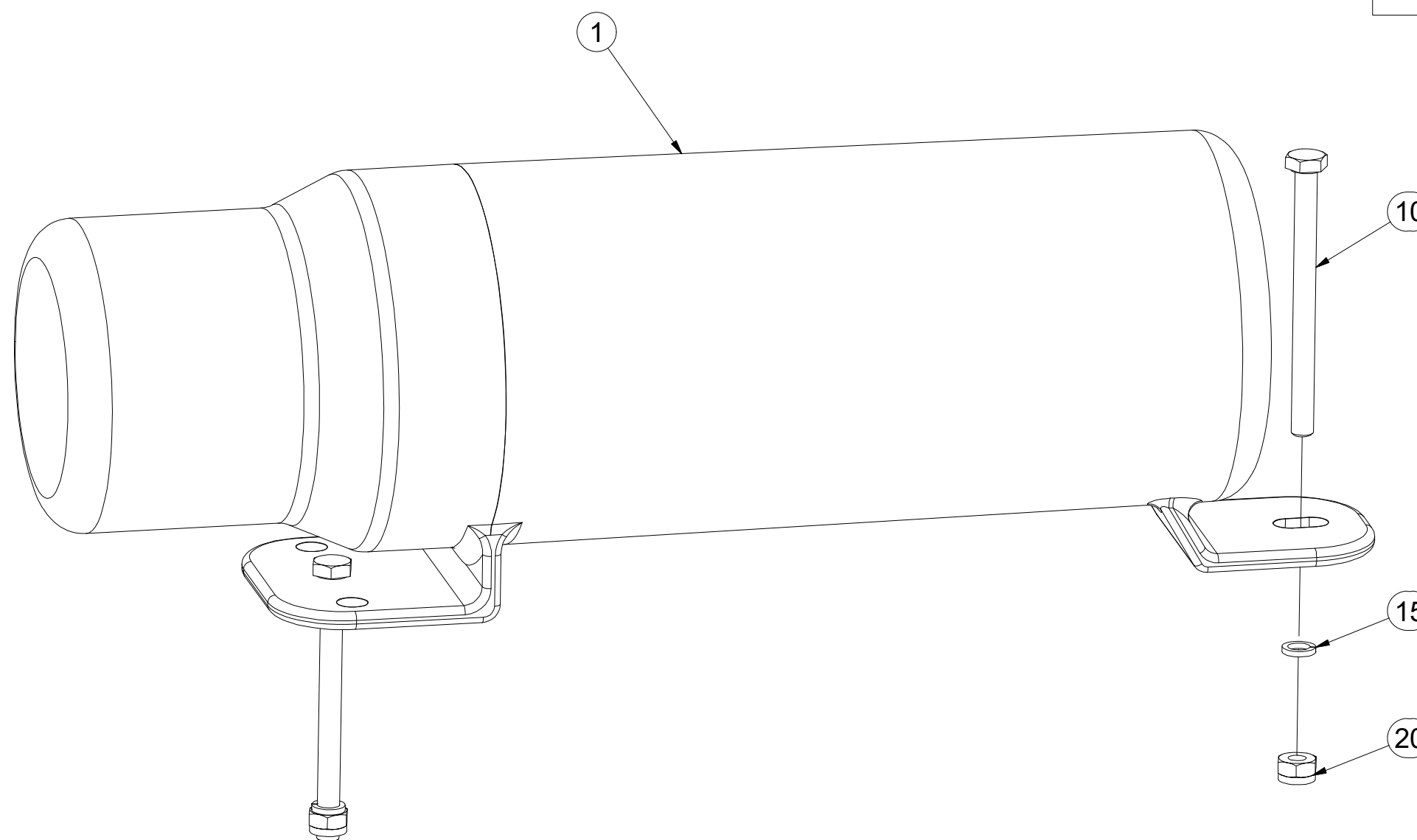
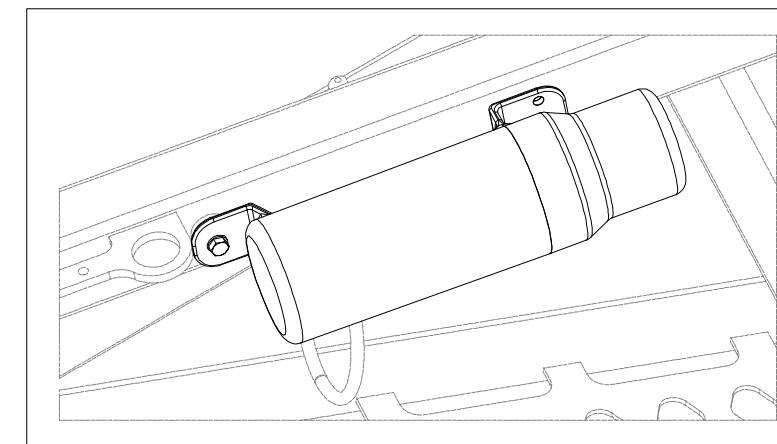

Pos.	Part Number	Pcs.
1	m15900	1
10	m16453	2
15	m01200	2
20	m05560	2

☉ SPOJOVACÍ TÁHLO

☉ VERBINDUNGSSTANGE

☉ TIGE DE RACCORDEMENT

**4003966**

☉ CONNECTING ROD

☉ СОЕДИНИТЕЛЬНАЯ ТЯГА

☉ KORBOWÓD

**Farmet**

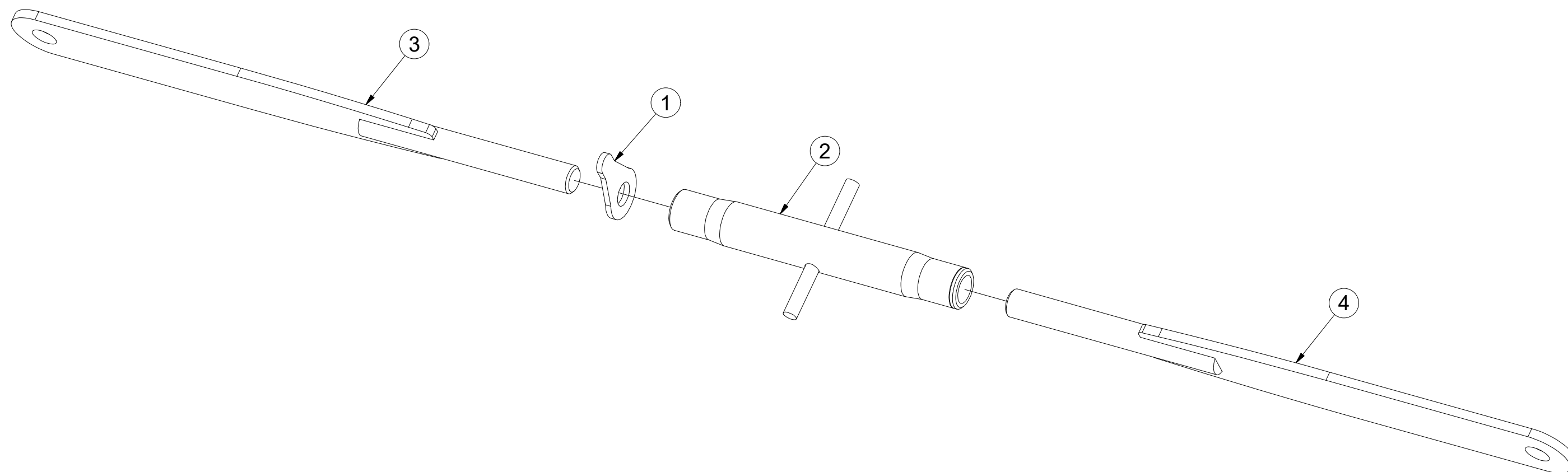
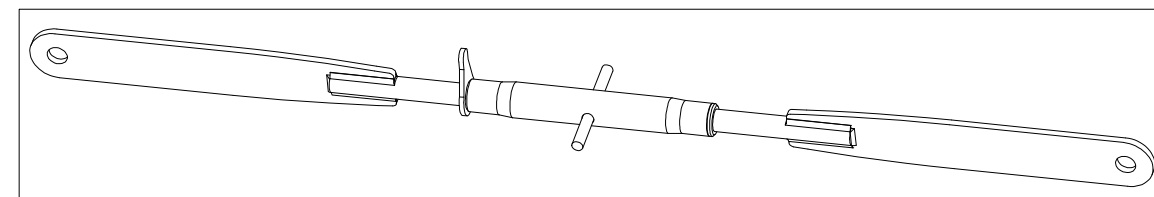

Poz	Číslo součásti	Ks
1	m08881	1
2	m08880	1
3	4003961	1
4	4003962	1

ⒸZ TÁHLO SKLÁPĚNÍ

Ⓓ ZUGSTANGE ZUR KIPPUNG

Ⓕ TIGE DU BASCULEMENT

ⒸB TILTING PULL ROD

ⒸU ТЯГА СКЛАДЫВАНИЯ

ⒸL CIĘGŁO PRZECHYLANIA



**4005363**

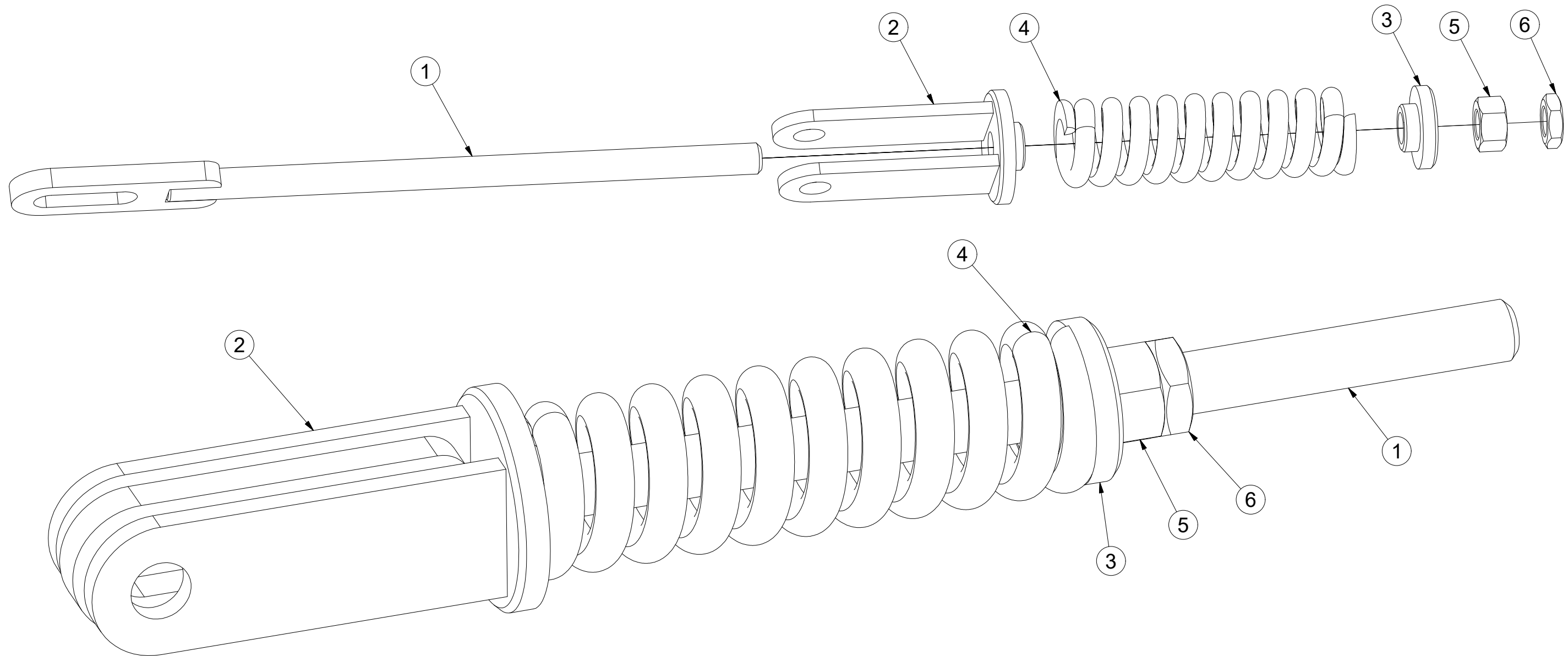

Pos	Part Number	Pcs.
1	4005358	1
2	4005361	1
3	4000023	1
5	m01309	1
4	m06482	1
6	m04043	1

CZ NASAZOVACÍ KLIKA  
 D EINSTELLKURBEL  
 F MANIVELLE AMOVIBILE

GB PRESS-ON HANDLE  
 RU НАСАЖИВАЕМАЯ РУКОЯТКА  
 PL KLAMKA MOCOWANA



**4003087**

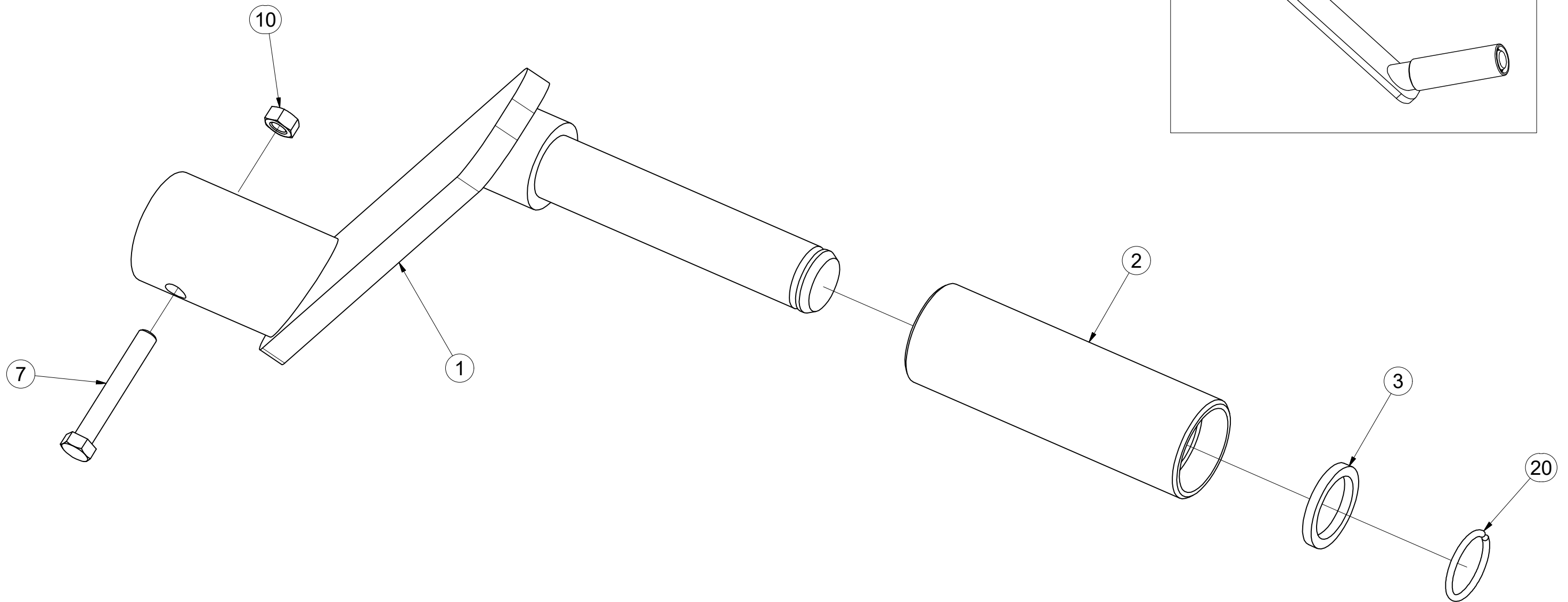

Pos.	Part Number	Pcs.
1	4003092	1
2	4001533	1
3	4004828	1
7	m04641	1
10	m01295	1
20	m06561	1

☞ SADA ČEPŮ TBZ 3

☞ BOLZENSATZ TBZ 3

☞ KIT D'EMBOUITS TBZ 3

**3005554**

☞ SET OF TBZ 3 PINS

☞ КОМПЛЕКТ ПАЛЬЦЕВ TBZ 3

☞ ZESTAW CZOPÓW TBZ 3

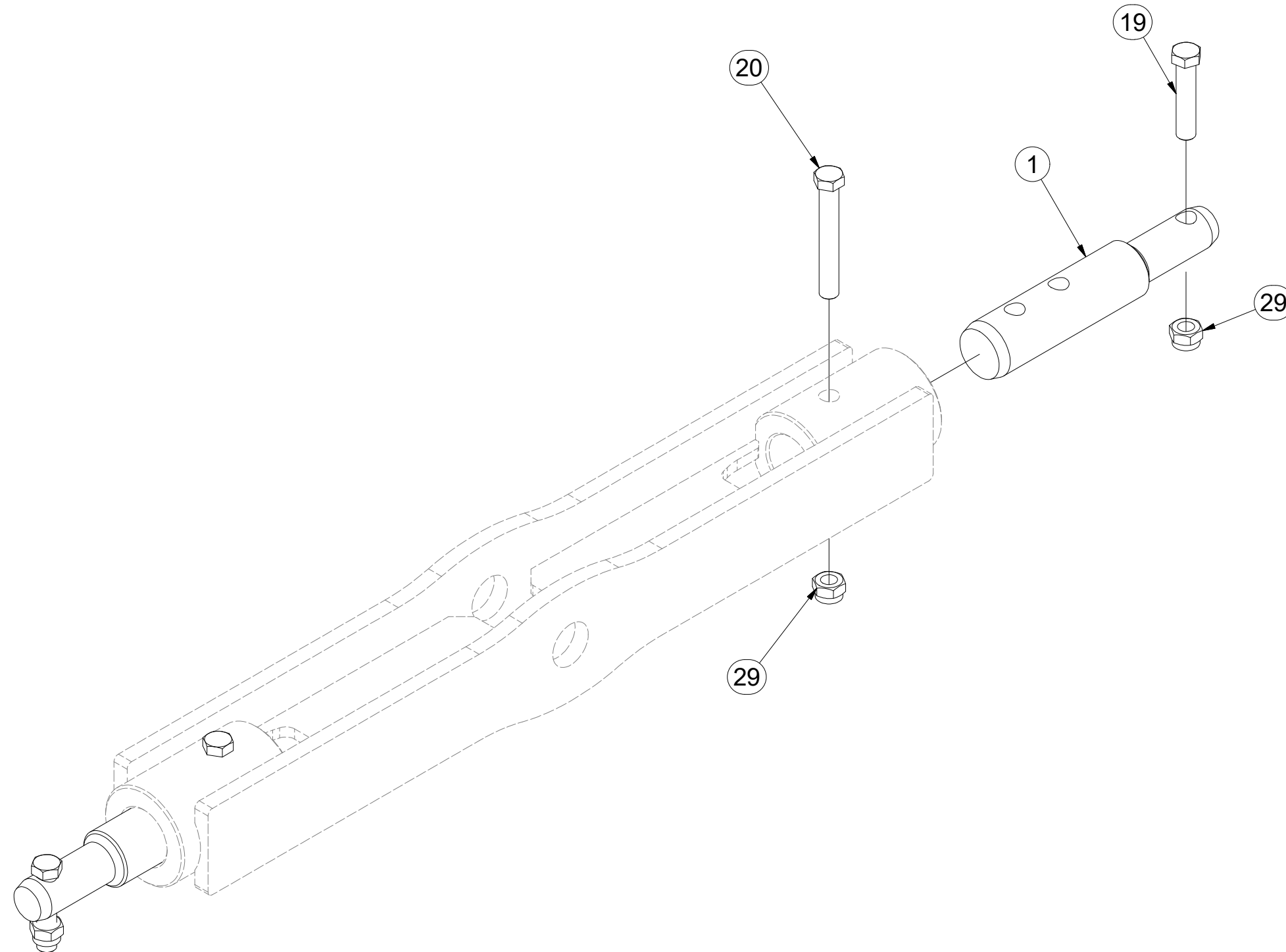
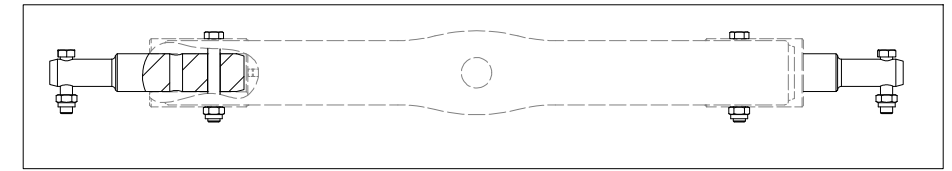
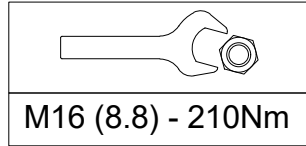

Pos.	Part Number	Pcs.
1	4007412	2
19	m01133	2
20	m02970	2
29	m03683	4



Ⓒ SADA KYPŘIČŮ STOP

Ⓓ SPURENLOCKERERSATZ

Ⓕ KIT DE CULTIVATEURS DE TRACES

Ⓖ SET OF TRACK CULTIVATORS

Ⓔ КОМПЛЕКТ РЫХЛИТЕЛЕЙ КОЛЕИ

Ⓗ ZESTAW SPULCHNIACZY ŚLADÓW



**3005535**

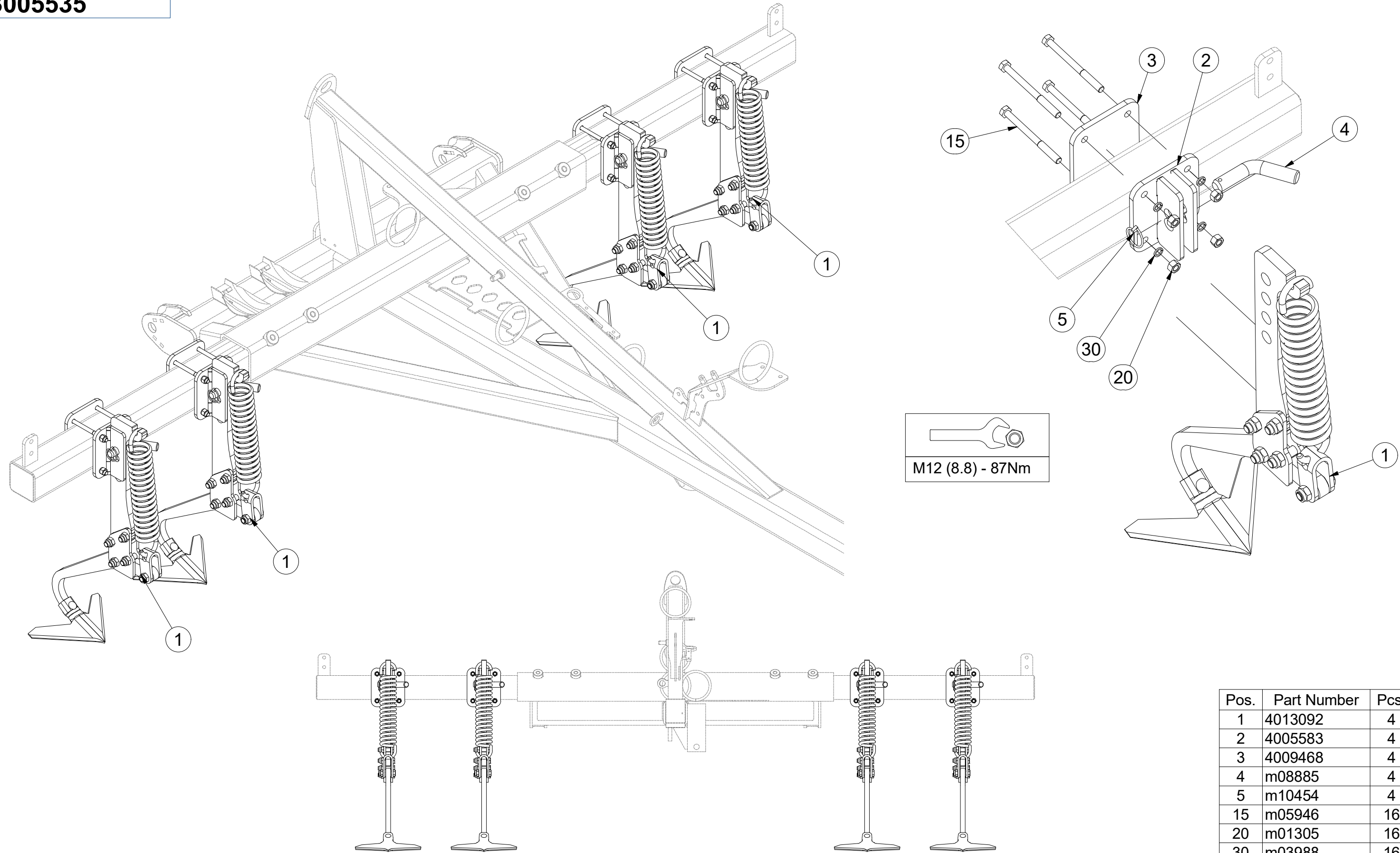

Pos.	Part Number	Pcs.
1	4013092	4
2	4005583	4
3	4009468	4
4	m08885	4
5	m10454	4
15	m05946	16
20	m01305	16
30	m03988	16

Ⓒ KYPŘIČ STOP

Ⓓ SPURENLOCKERER

Ⓕ CULTIVATEUR DES TRACES

Ⓖ TRACK CULTIVATOR

Ⓡ РЫХЛИТЕЛЬ КОЛЕИ

Ⓟ SPULCHNIARKA STÓP



4013092

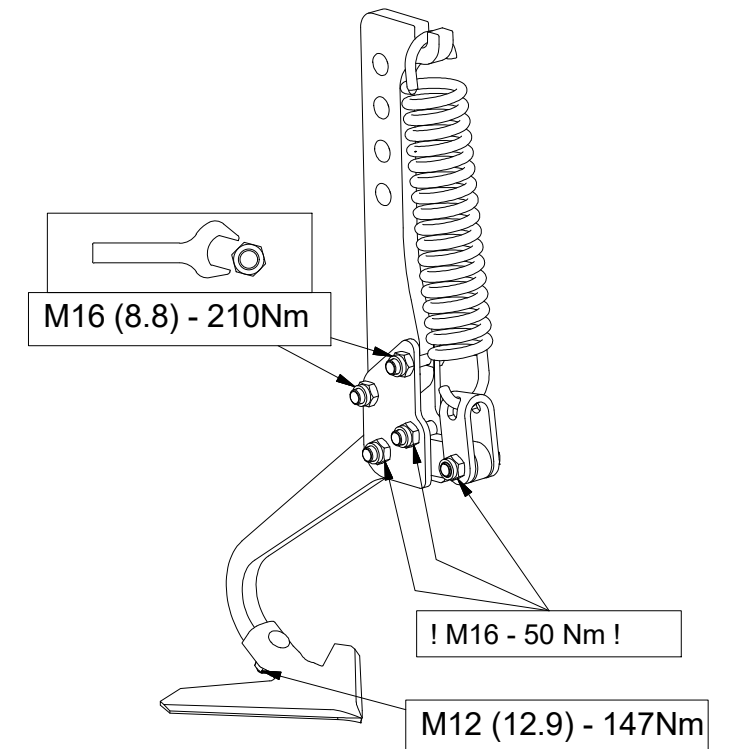
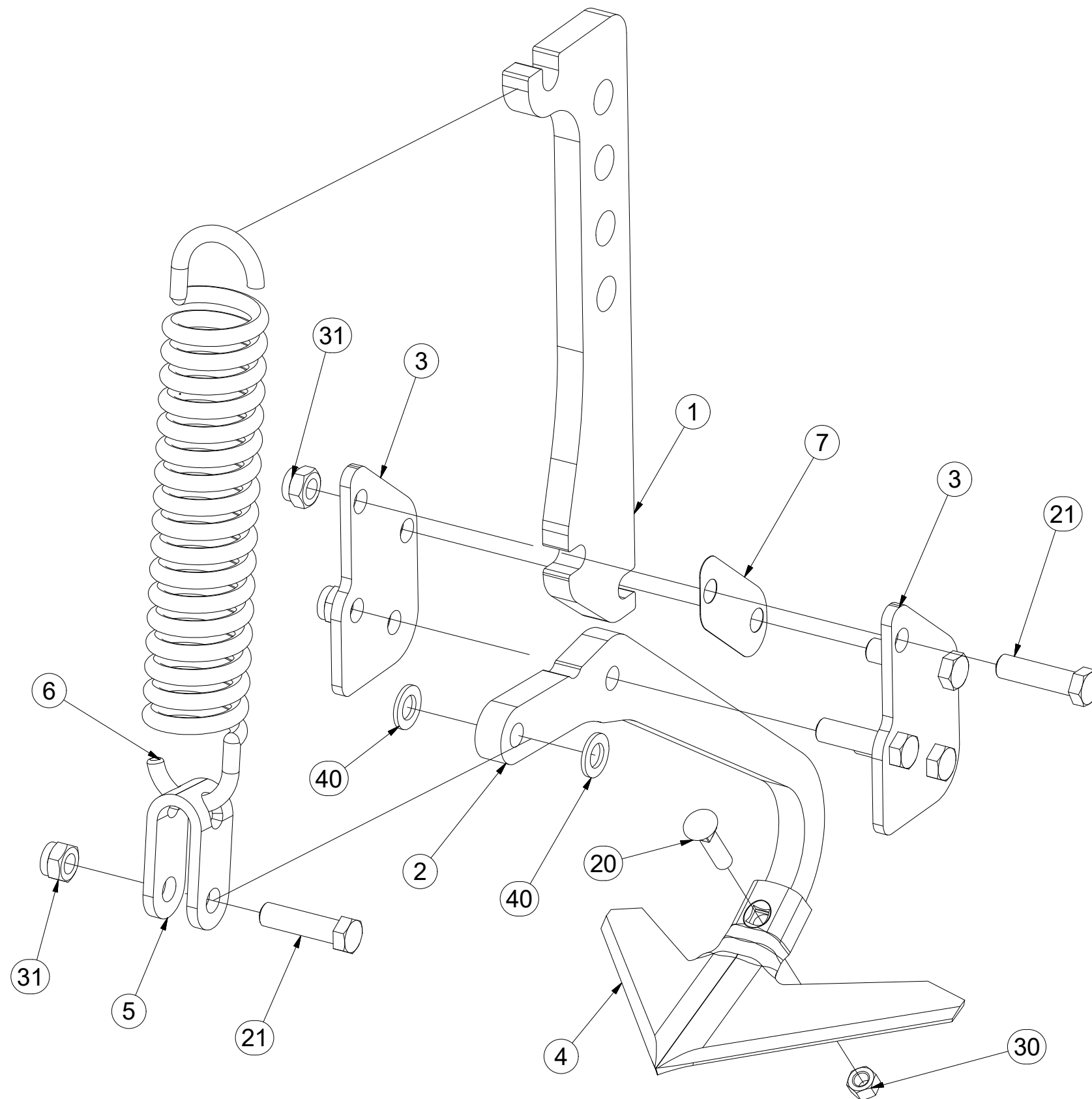

Pos.	Part Number	Pcs.
1	4017307	1
2	4007379	1
3	4005582	2
4	3000236-KOO	1
5	4005445	1
6	m02597	1
7	4005591	1
20	m10440	1
21	m00619	5
30	m10439	1
31	m03683	5
40	m01219	2

ⒸZ SADA PŘEDNÍCH SMYKŮ

Ⓓ SATZ VORDERE ACKERSCHLEPPEN

Ⓕ KIT DE NIVELEURS AVANT

ⒸGB SET OF FRONT LEVELLING BARS

ⒸRU КОМПЛЕКТ ПЕРЕДНИХ БОРОН

ⒸPL ZESTAW PRZEDNICH WŁÓK

**Farmet**

**3006365**

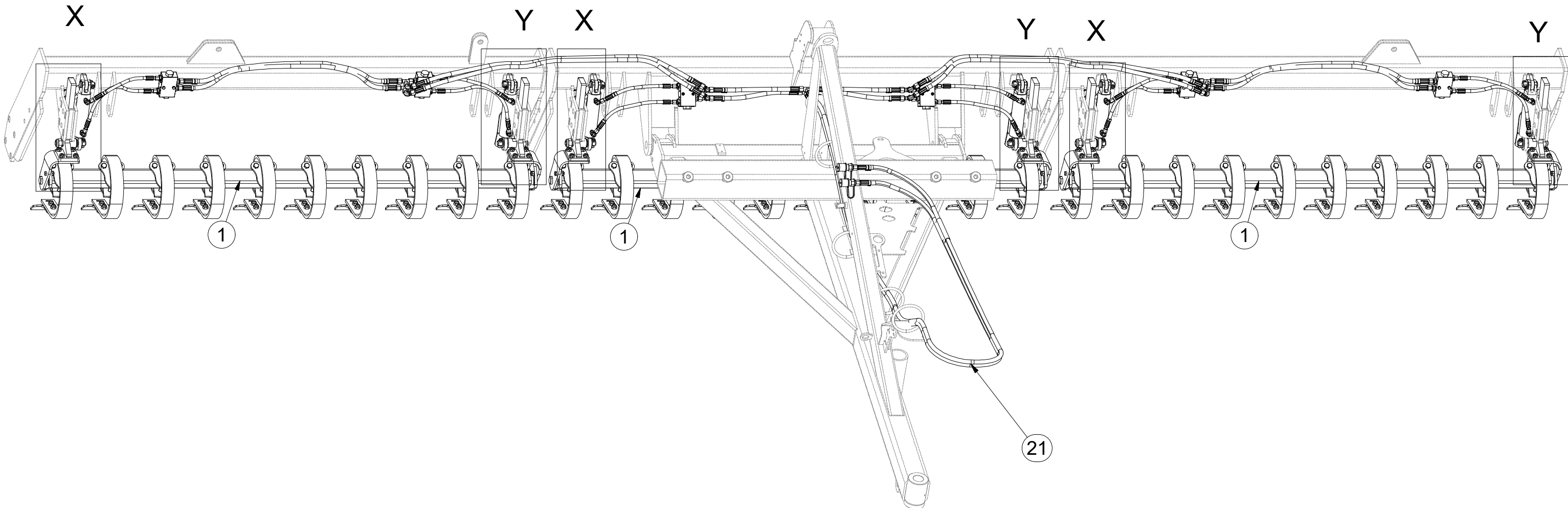

Pos.	Part Number	Pcs.
1	3007211	3
21	m16046	1

Ⓒ SADA PŘEDNÍCH SMYKŮ

Ⓓ SATZ VORDERE ACKERSCHLEPPEN

Ⓕ KIT DE NIVELEURS AVANT

Ⓖ SET OF FRONT LEVELLING BARS

Ⓡ КОМПЛЕКТ ПЕРЕДНИХ БОРОН

Ⓟ ZESTAW PRZEDNICH WŁÓK



**3006365**

Pos.	Part Number	Pcs.	Pos.	Part Number	Pcs.
2	4012749	3	55	m02254	12
4	4013870	3	56	m09870	12
6	4010386	3	61	m05648	6
8	4015532	6	62	m03775	30
9	8000734-90007	6	63	m04301	12
10	4015710	6	64	m03683	12
11	4015712	6	65	m04503	12
12	4012714	6	71	m01229	6
21	m16046	1	72	m02157	18
52	m11516	30	73	m03988	12
53	m04343	6	74	m14944	12
54	m06077	6			



M12 (8.8) - 87Nm
M16 (8.8) - 210Nm
M20 (8.8) - 411Nm
M8 (8.8) - 25Nm

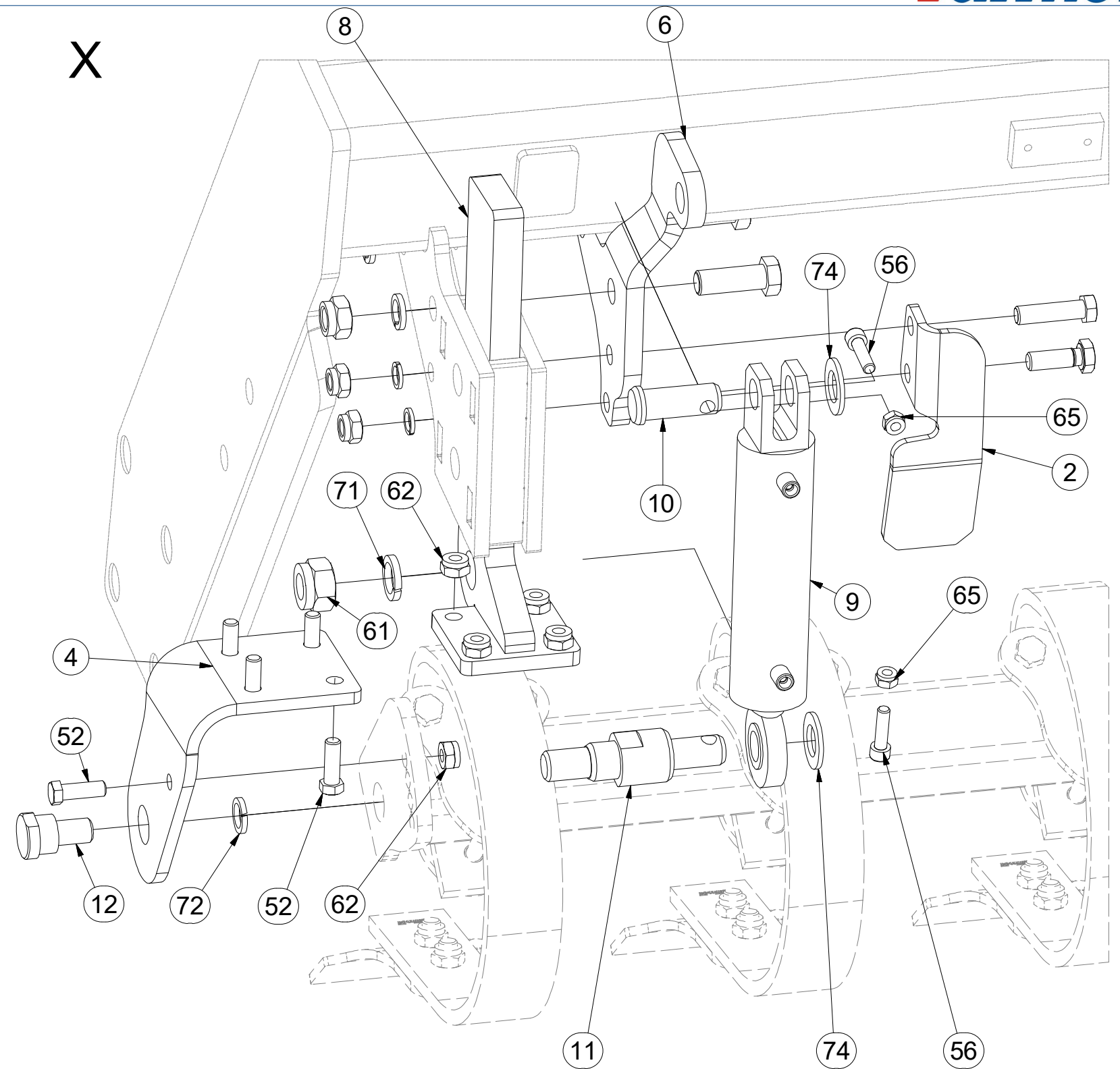
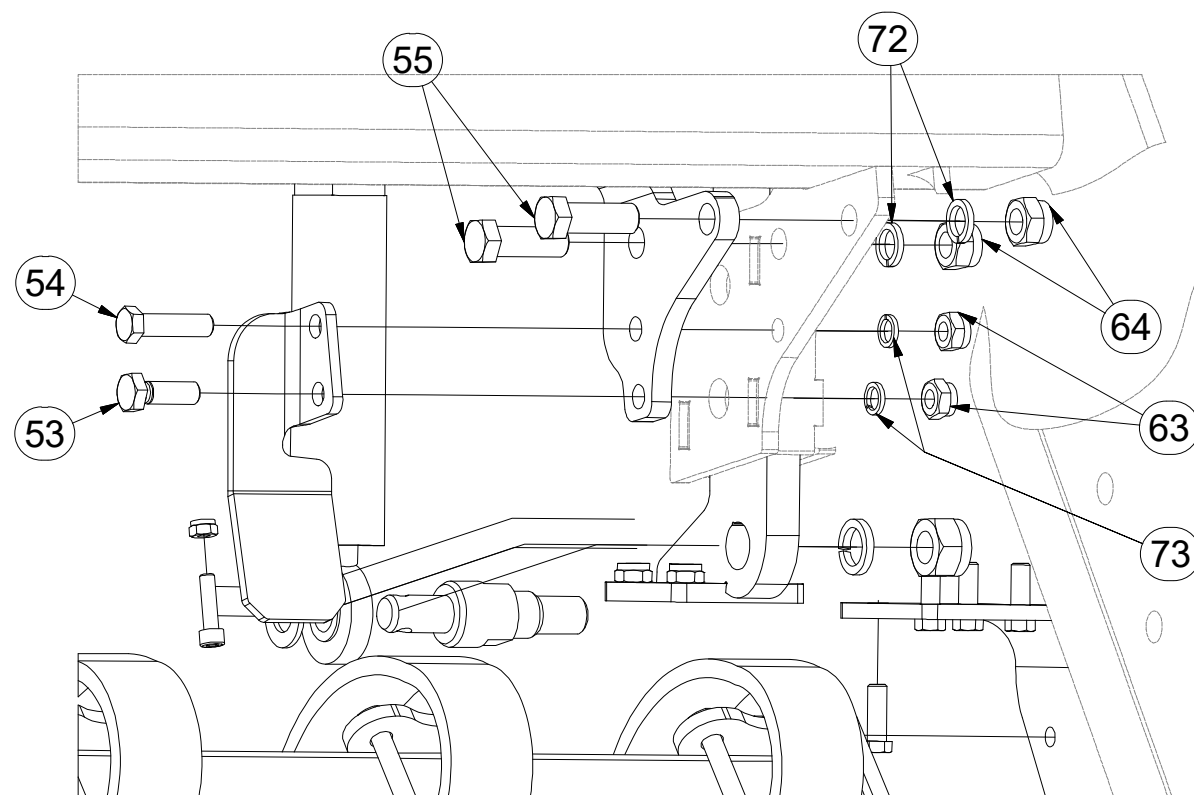

ⒸZ SADA PŘEDNÍCH SMYKŮ

Ⓓ SATZ VORDERE ACKERSCHLEPPEN

Ⓕ KIT DE NIVELEURS AVANT

ⒼB SET OF FRONT LEVELLING BARS

ⒺU КОМПЛЕКТ ПЕРЕДНИХ БОРОН

ⒽL ZESTAW PRZEDNICH WŁÓK



**3006365**

Y

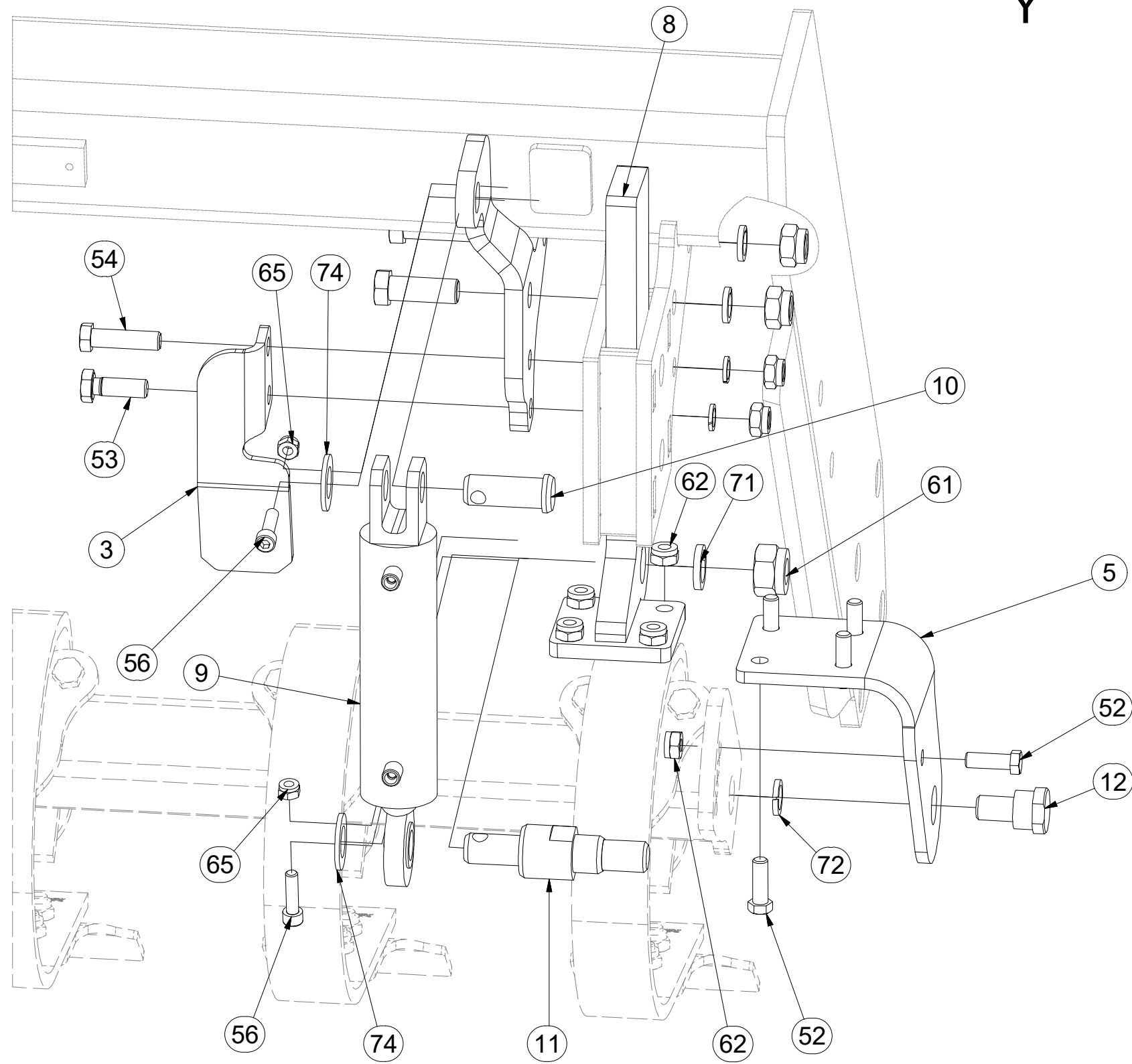

M12 (8.8) - 87Nm
M16 (8.8) - 210Nm
M20 (8.8) - 411Nm

Pos.	Part Number	Pcs.	Pos.	Part Number	Pcs.
3	4012750	3	55	m02254	12
5	4013871	3	56	m09870	12
7	4010387	3	61	m05648	6
8	4015532	6	62	m03775	30
9	8000734-90007	6	63	m04301	12
10	4015710	6	64	m03683	12
11	4015712	6	65	m04503	12
12	4012714	6	71	m01229	6
52	m11516	30	72	m02157	18
53	m04343	6	73	m03988	12
54	m06077	6	74	m14944	12

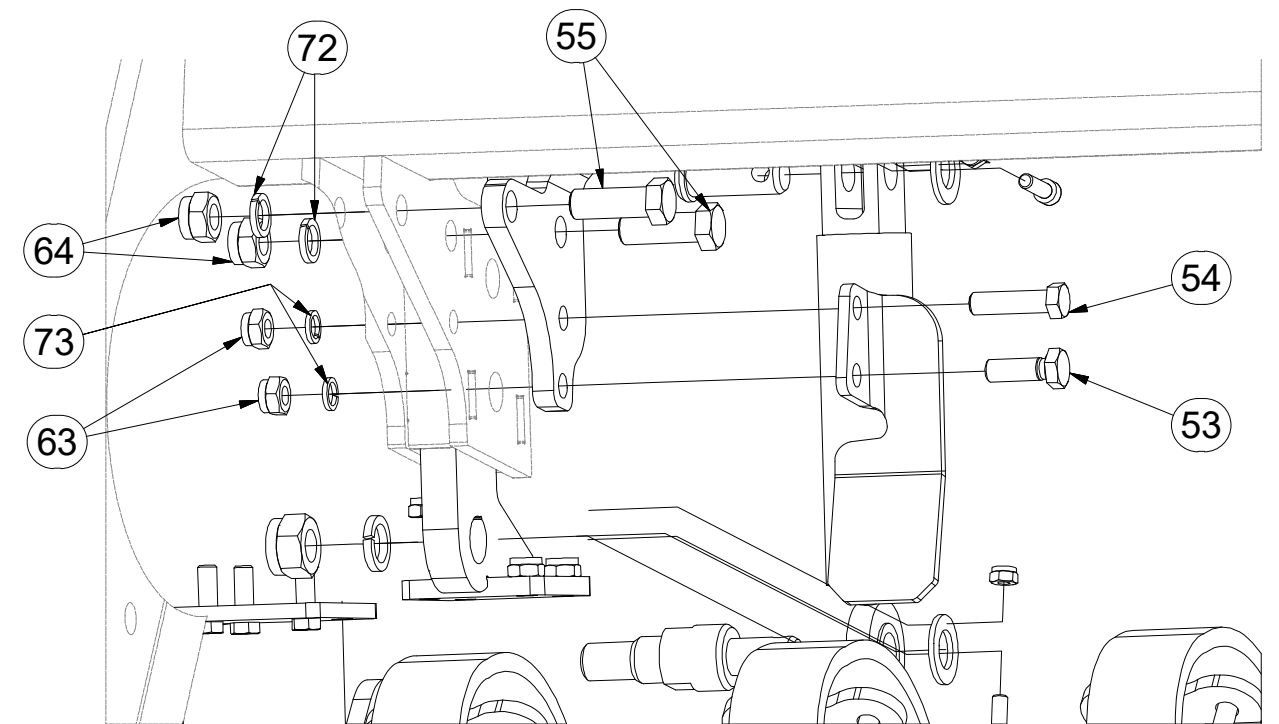

ⒸZ SADA PŘEDNÍCH SMYKŮ

Ⓓ SATZ VORDERE ACKERSCHLEPPEN

Ⓕ KIT DE NIVELEURS AVANT

**m16046**

ⒸB SET OF FRONT LEVELLING BARS

Ⓔ КОМПЛЕКТ ПЕРЕДНИХ БОРОН

Ⓖ ZESTAW PRZEDNICH WŁÓK

**Farmet**

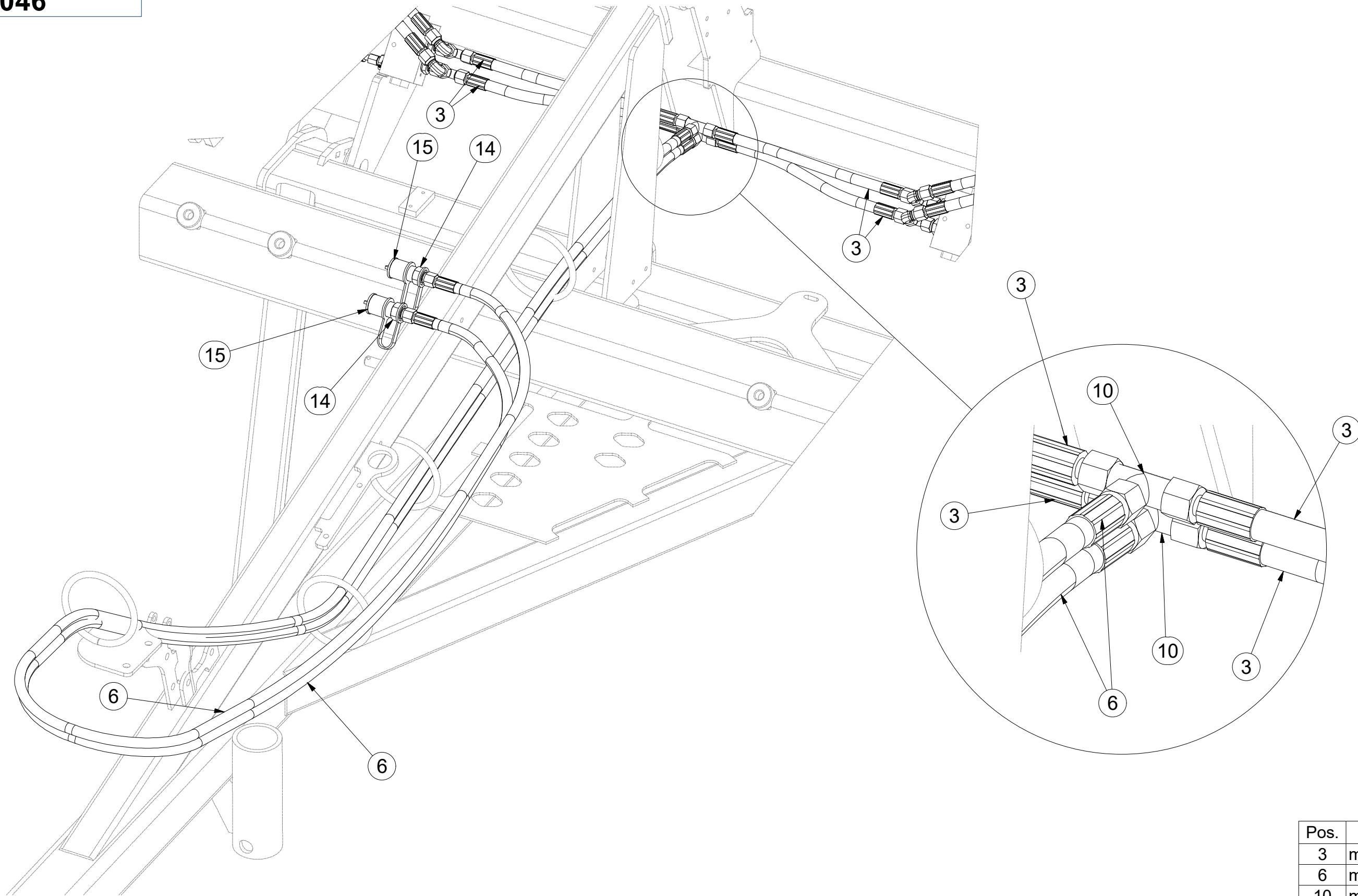

Pos.	Part Number	Pcs.
3	m09627	4
6	m04087	2
10	m03889	2
14	m03849	2
15	m03743	2

ⒸZ SADA PŘEDNÍCH SMYKŮ

Ⓓ SATZ VORDERE ACKERSCHLEPPEN

Ⓕ KIT DE NIVELEURS AVANT

ⒼB SET OF FRONT LEVELLING BARS

ⒺU КОМПЛЕКТ ПЕРЕДНИХ БОРОН

ⒽL ZESTAW PRZEDNICH WŁÓK



**3006365**

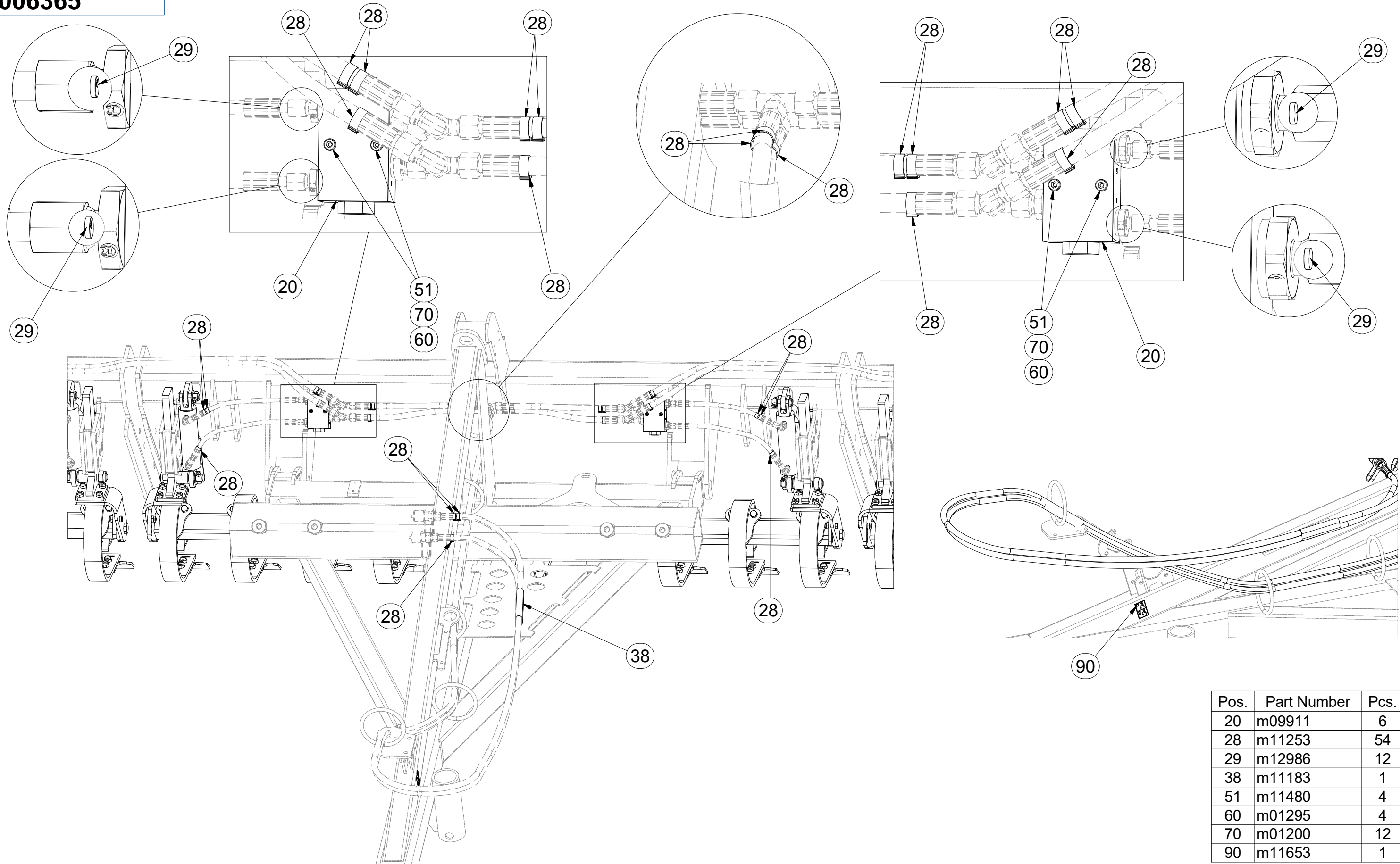

Pos.	Part Number	Pcs.
20	m09911	6
28	m11253	54
29	m12986	12
38	m11183	1
51	m11480	4
60	m01295	4
70	m01200	12
90	m11653	1

ⒸZ SADA PŘEDNÍCH SMYKŮ

Ⓓ SATZ VORDERE ACKERSCHLEPPEN

Ⓕ KIT DE NIVELEURS AVANT

ⒸGB SET OF FRONT LEVELLING BARS

ⒸRU КОМПЛЕКТ ПЕРЕДНИХ БОРОН

ⒸPL ZESTAW PRZEDNICH WŁÓK



**m16046**

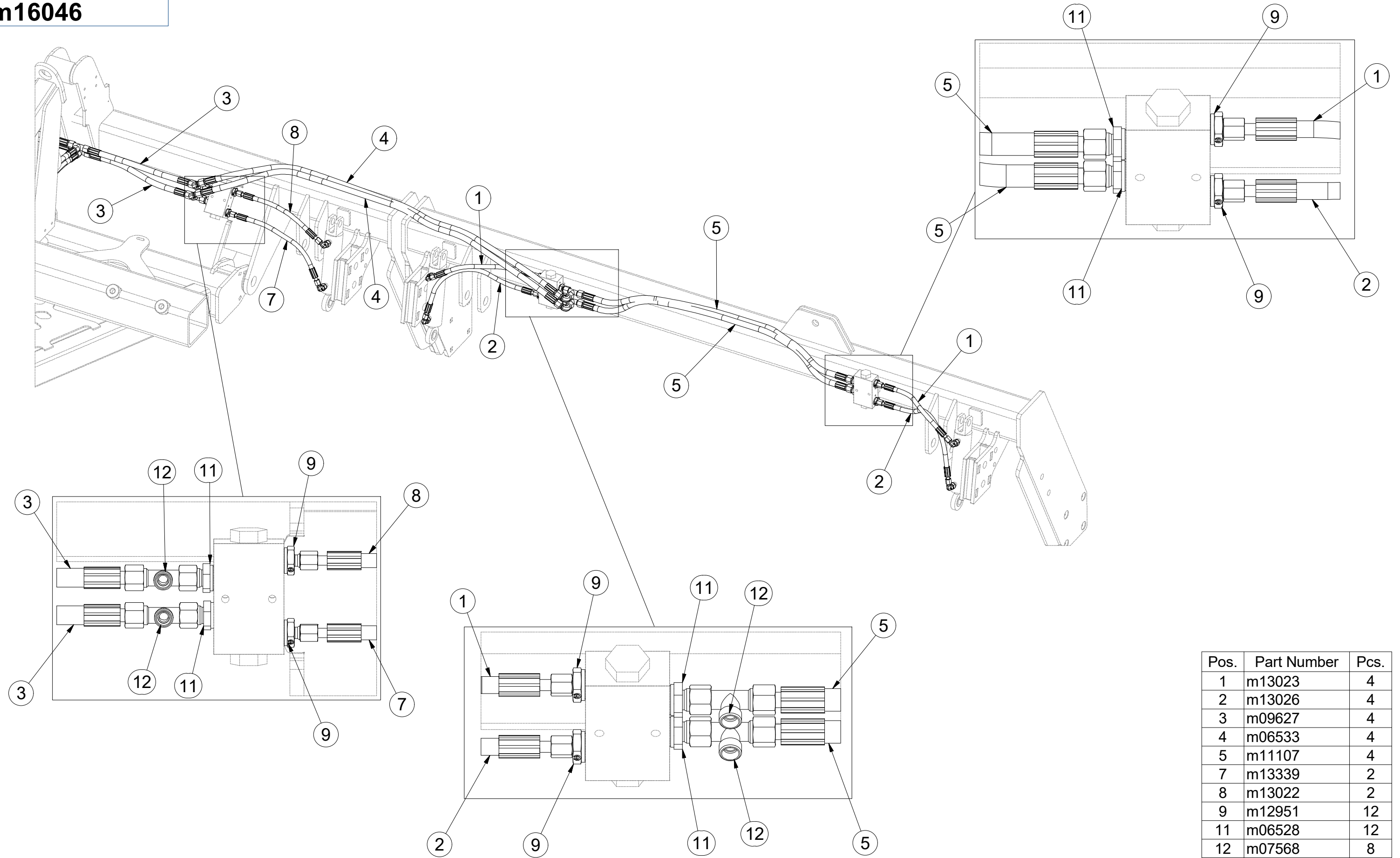

Pos.	Part Number	Pcs.
1	m13023	4
2	m13026	4
3	m09627	4
4	m06533	4
5	m11107	4
7	m13339	2
8	m13022	2
9	m12951	12
11	m06528	12
12	m07568	8



ⒸZ SADA PŘEDNÍCH SMYKŮ

Ⓓ SATZ VORDERE ACKERSCHLEPPEN

Ⓕ KIT DE NIVELEURS AVANT

ⒼB SET OF FRONT LEVELLING BARS

ⒶR КОМПЛЕКТ ПЕРЕДНИХ БОРОН

ⒶL ZESTAW PRZEDNICH WŁÓK



**3006365**

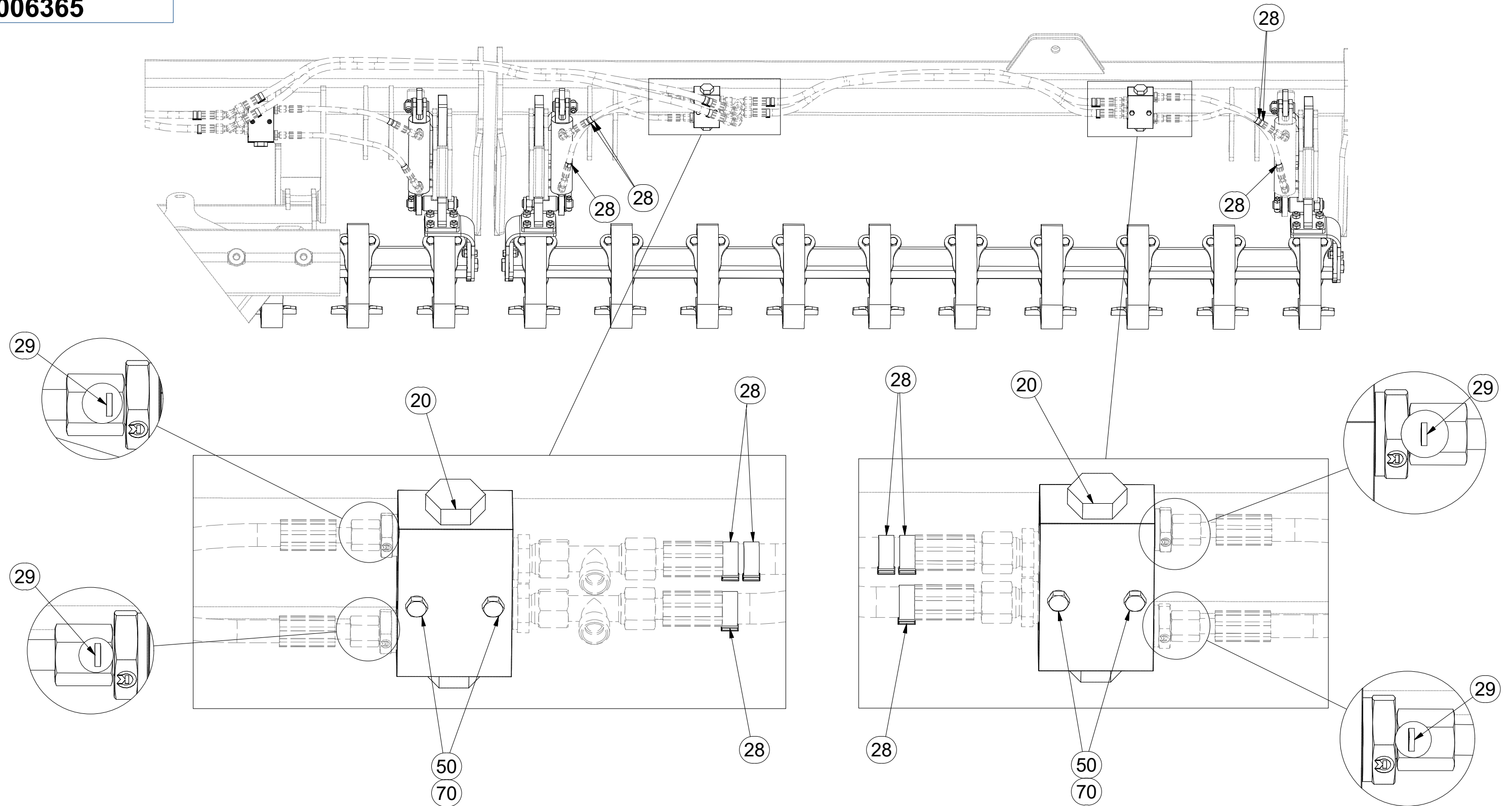

Pos.	Part Number	Pcs.
20	m09911	6
28	m11253	54
29	m12986	12
50	m05561	8
70	m01200	12

ⒸZ SADA PŘEDNÍCH SMYKŮ

Ⓓ SATZ VORDERE ACKERSCHLEPPEN

Ⓕ KIT DE NIVELEURS AVANT

ⒸB SET OF FRONT LEVELLING BARS

ⒸU КОМПЛЕКТ ПЕРЕДНИХ БОРОН

ⒸL ZESTAW PRZEDNICH WŁÓK



**m16046**

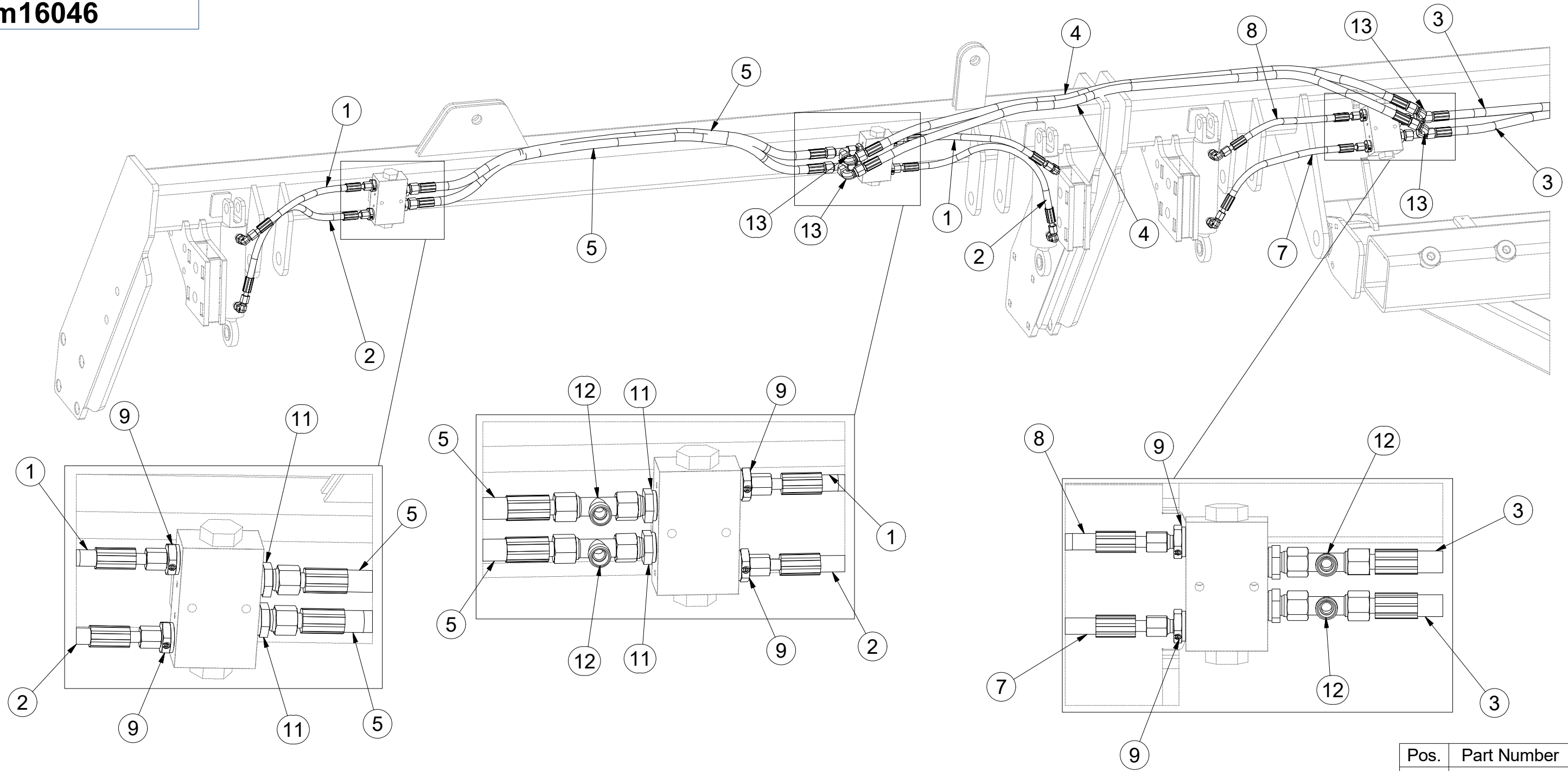

Pos.	Part Number	Pcs.
1	m13023	4
2	m13026	4
3	m09627	4
4	m06533	4
5	m11107	4
7	m13339	2
8	m13022	2
9	m12951	12
11	m06528	12
12	m07568	8
13	m06803	8

ⒸZ SADA PŘEDNÍCH SMYKŮ

Ⓓ SATZ VORDERE ACKERSCHLEPPEN

Ⓕ KIT DE NIVELEURS AVANT

ⒼB SET OF FRONT LEVELLING BARS

Ⓔ RU КОМПЛЕКТ ПЕРЕДНИХ БОРОН

Ⓖ PL ZESTAW PRZEDNICH WŁÓK



**3006365**

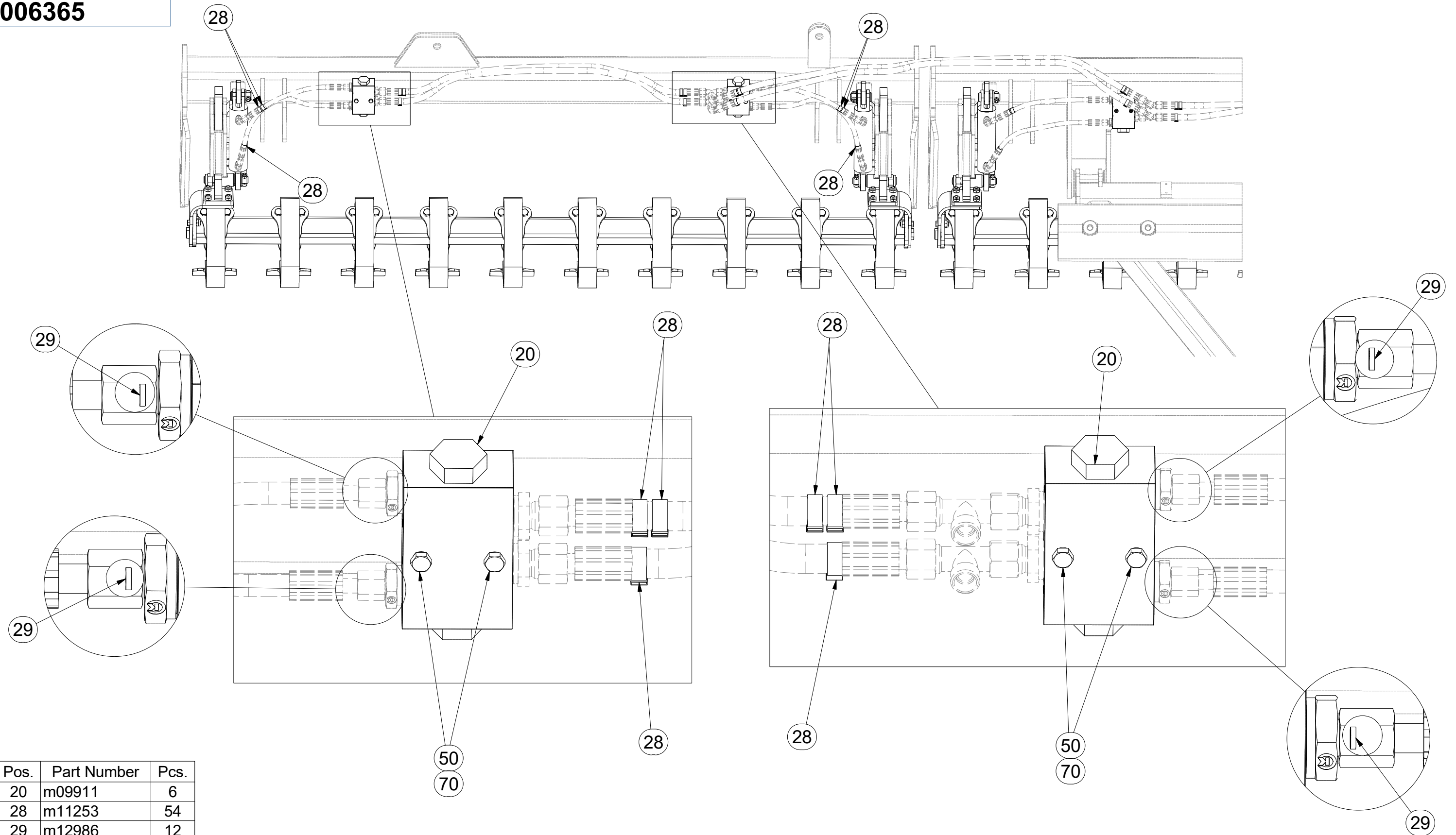

Pos.	Part Number	Pcs.
20	m09911	6
28	m11253	54
29	m12986	12
50	m05561	8
70	m01200	12

Ⓒ PŘEDNÍ SMYK

Ⓓ VORDERE ACKERSCHLEIFE

Ⓕ NIVELEUR AVANT

Ⓖ FRONT DRAG

Ⓡ ПЕРЕДНЯЯ БОРОНА

Ⓟ PRZEDNIA WŁÓKA



**3007211**

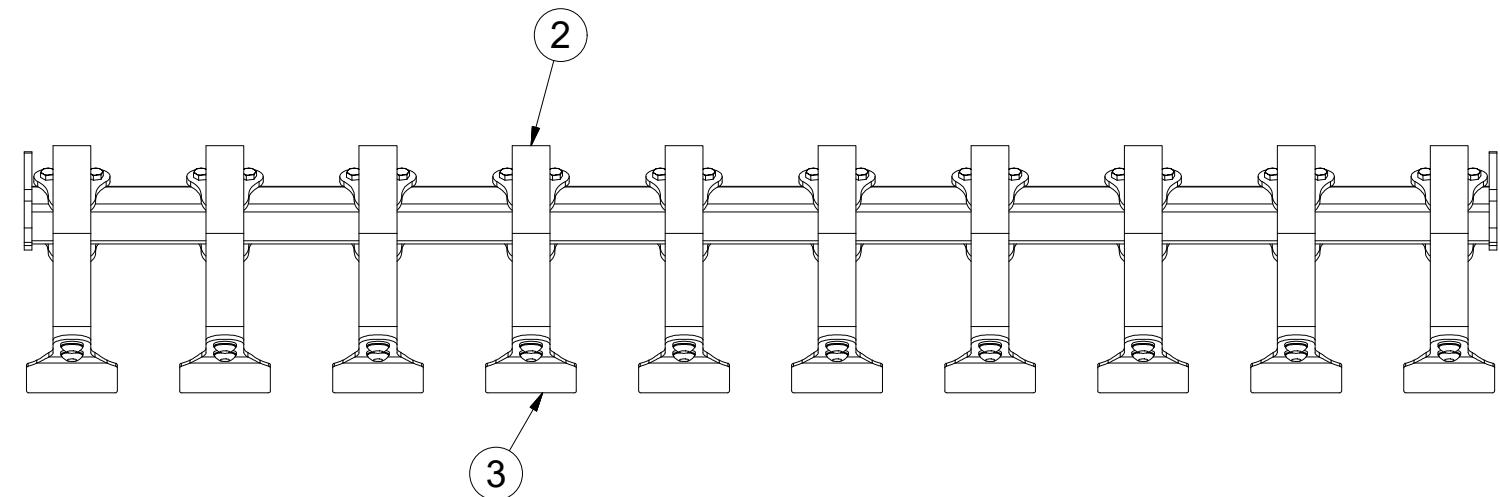
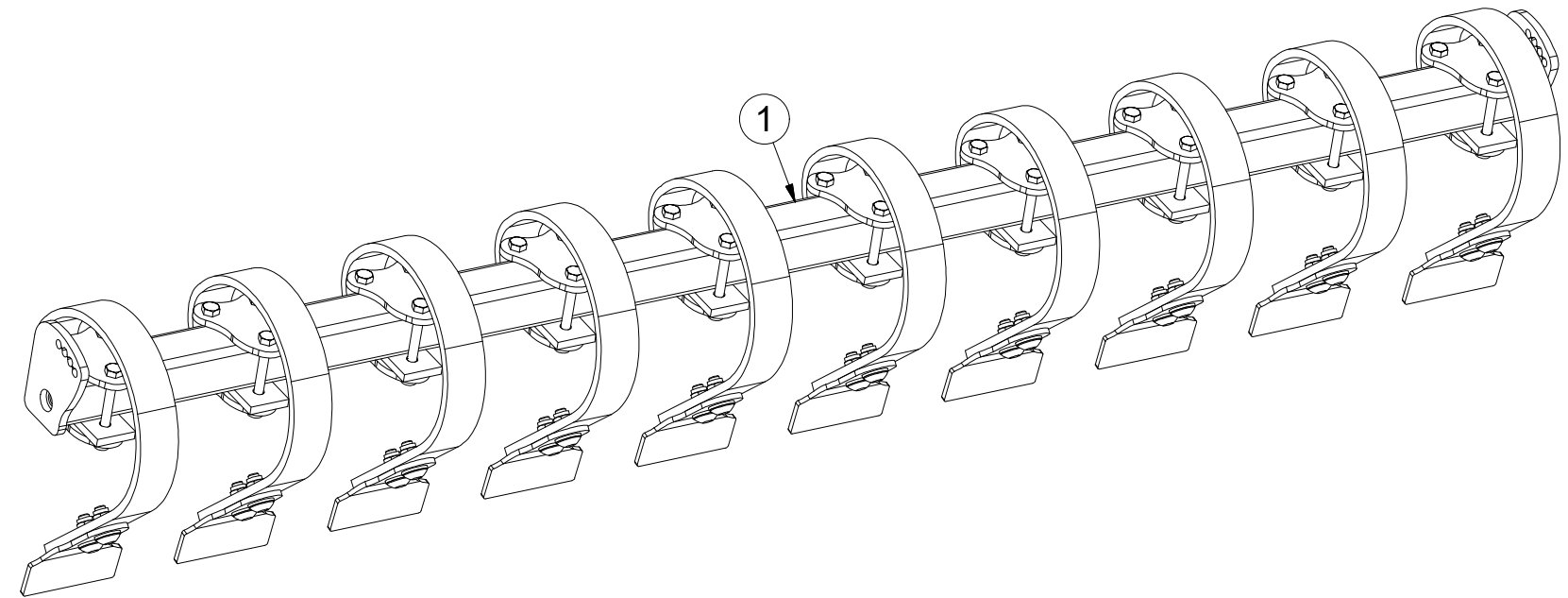
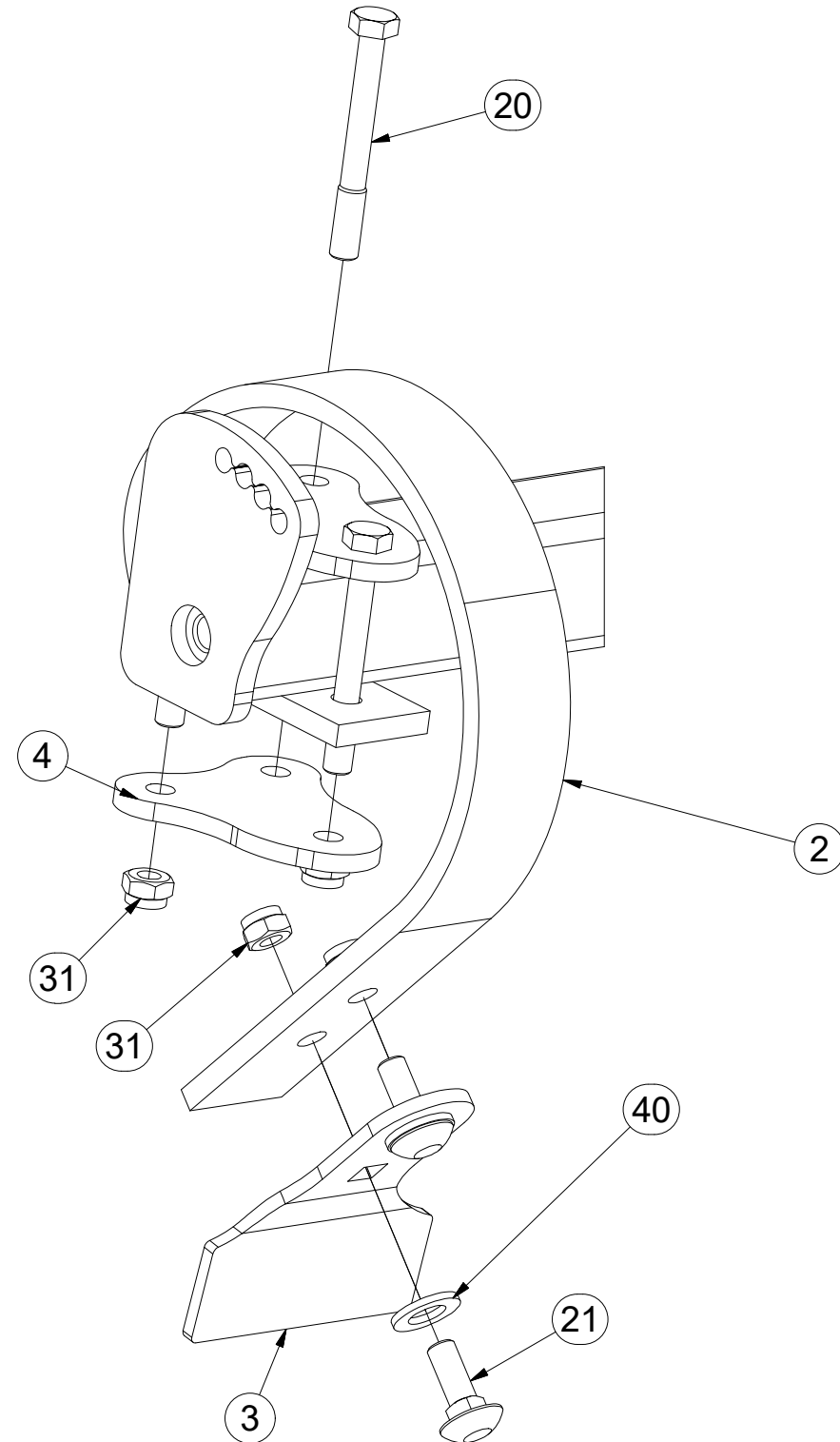

Pos.	Part Number	Pcs.
1	3007131	1
2	9003585	10
3	4014188	10
4	4013882	20
20	m11598	30
21	m10618	20
31	m04301	50
40	m01219	20

M12 (10.9) - 122Nm
M12 (8.8) - 87Nm

Ⓒ SADA PŘEDNÍCH VÁLCŮ

Ⓓ SATZ VORDERE WALZEN

Ⓕ KIT DE ROULEAUX AVANT

Ⓒ SET OF FRONT ROLLERS

Ⓓ КОМПЛЕКТ ПЕРЕДНИХ КАТКОВ

Ⓕ ZESTAW PRZEDNICH WAŁÓW



3005274

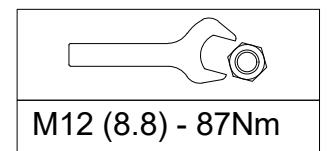
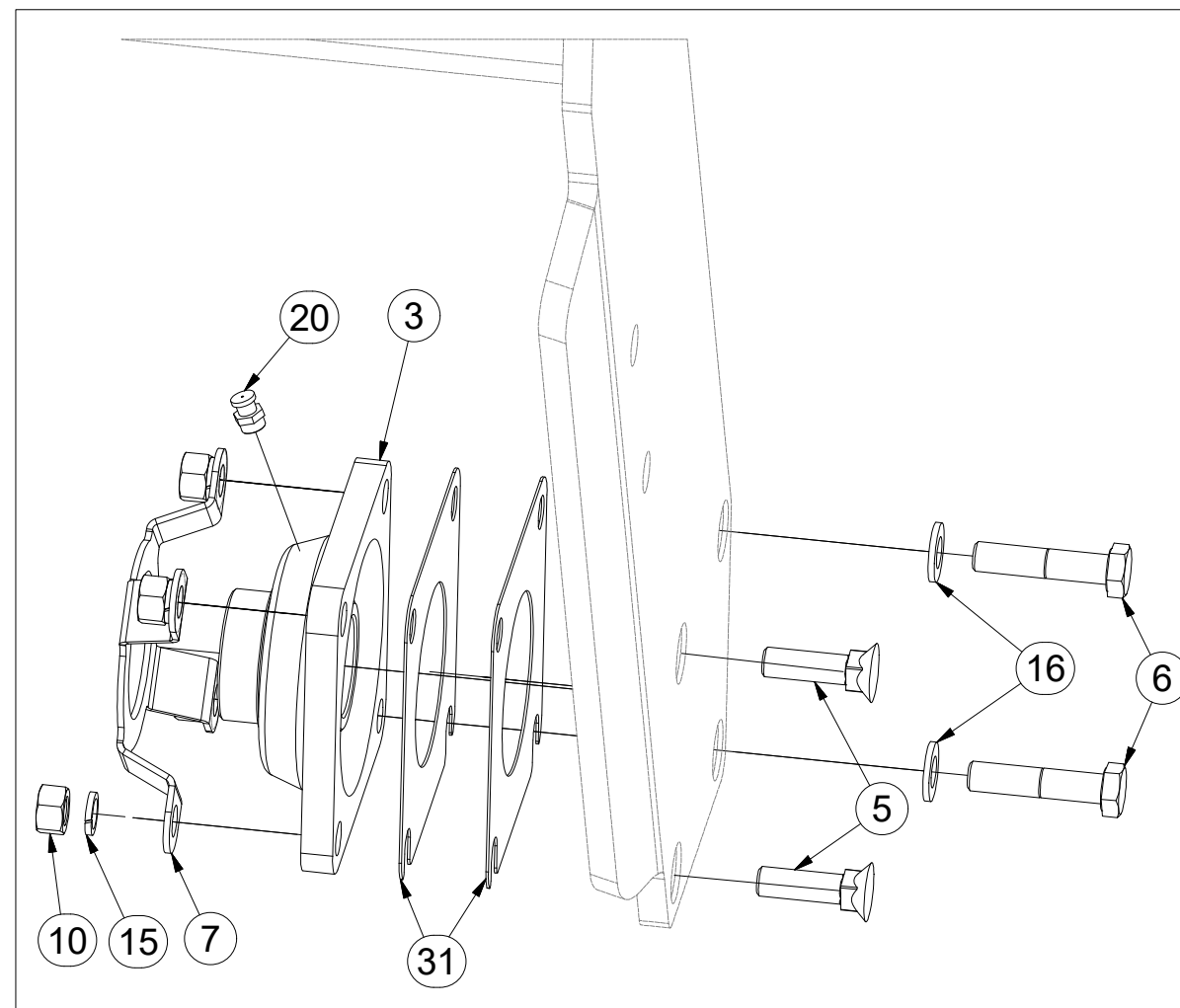
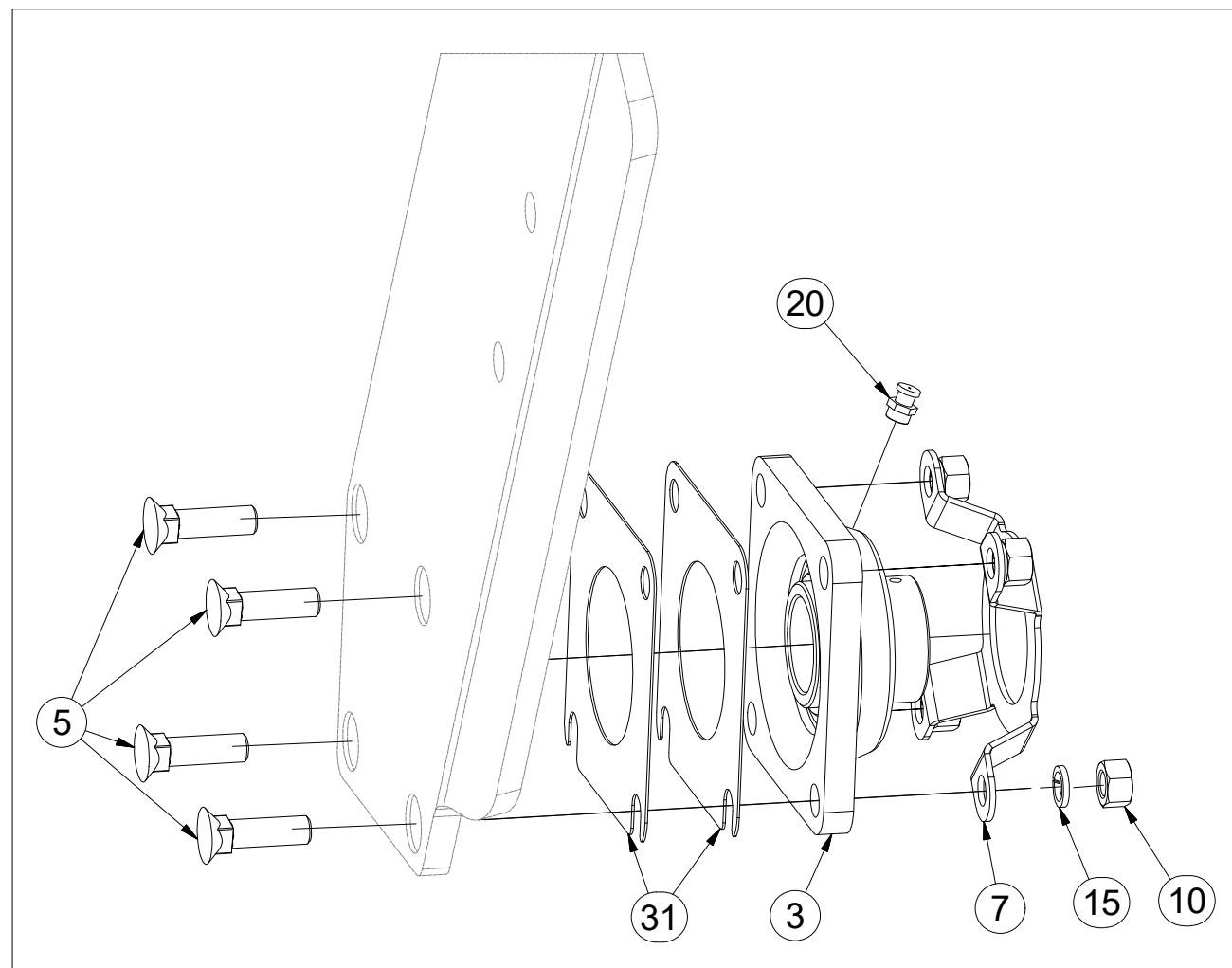
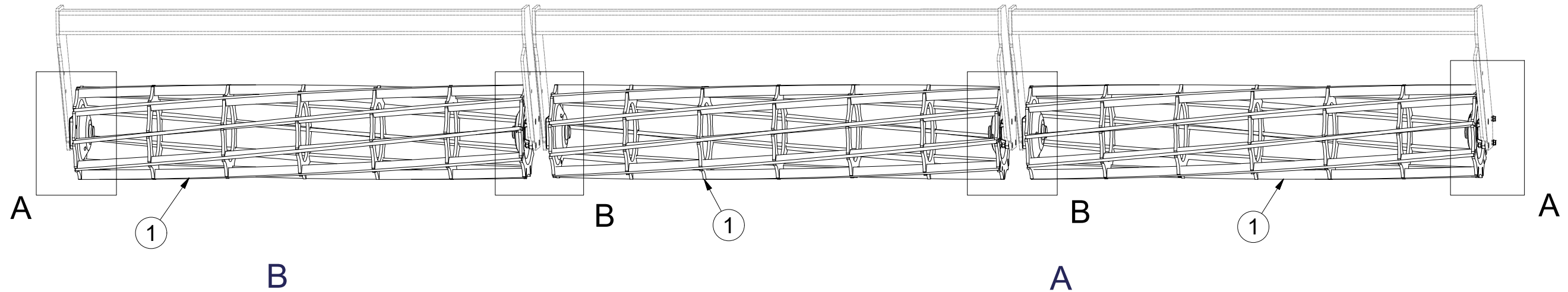

Pos.	Part Number	Pcs.
1	2000539	3
3	m09687	6
5	m03519	20
6	m04412	4
7	m12337	6
10	m01305	24
15	m03988	24
16	m01214	4
20	m10448	6
31	4016809	12

ⒸZ SADA OVLÁDÁNÍ RADLIC

Ⓓ STEUERSATZ PFLUGSCHAREN

Ⓕ KIT DE COMMANDE DES SOCS

ⒸB SET OF PLOUGHSHARE CONTROL

ⒸU КОМПЛЕКТ УПРАВЛЕНИЯ ЛАП

ⒸL ZESTAW STEROWANIA RADLICAMI



3005538

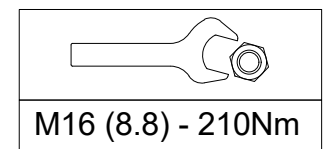
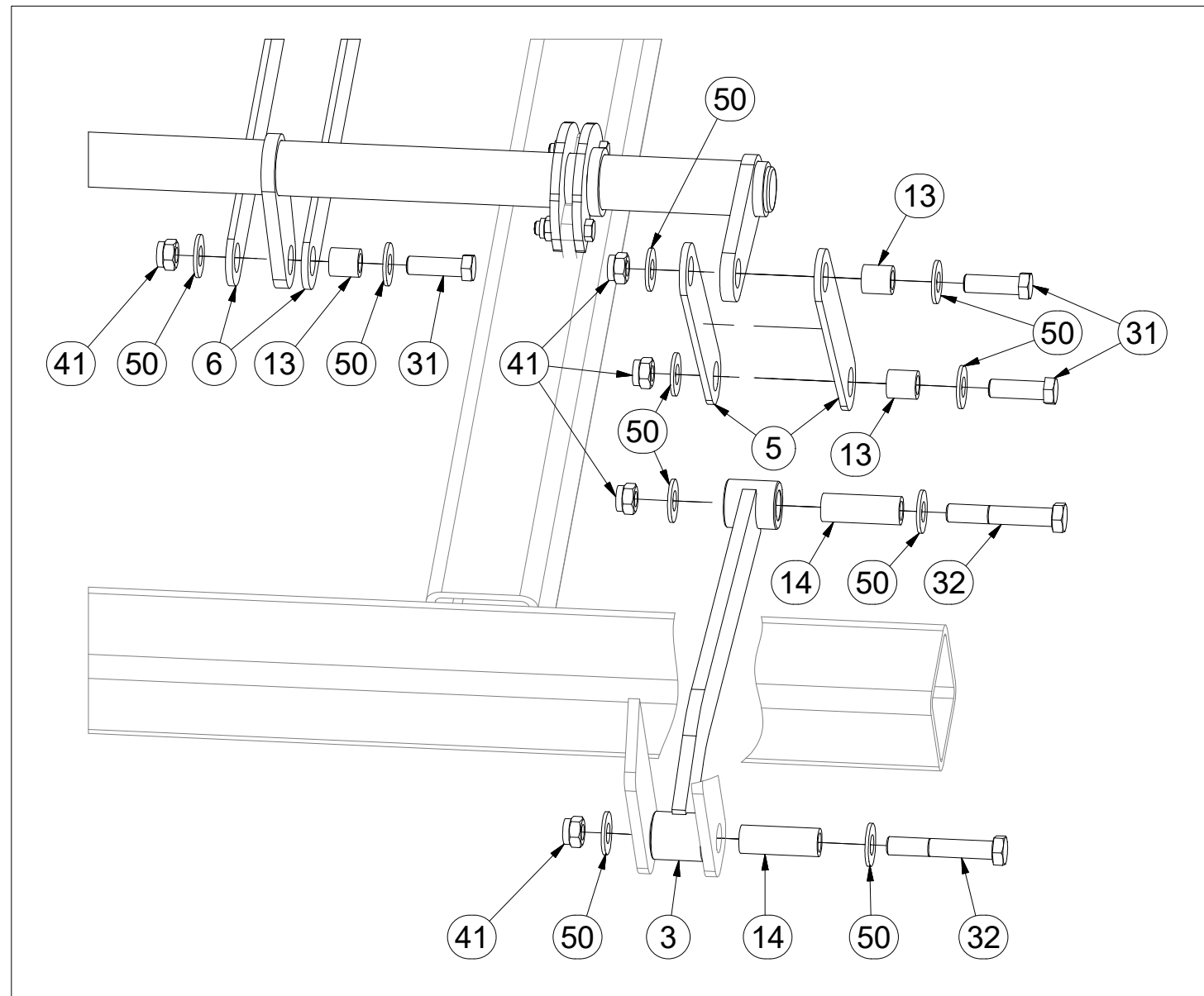
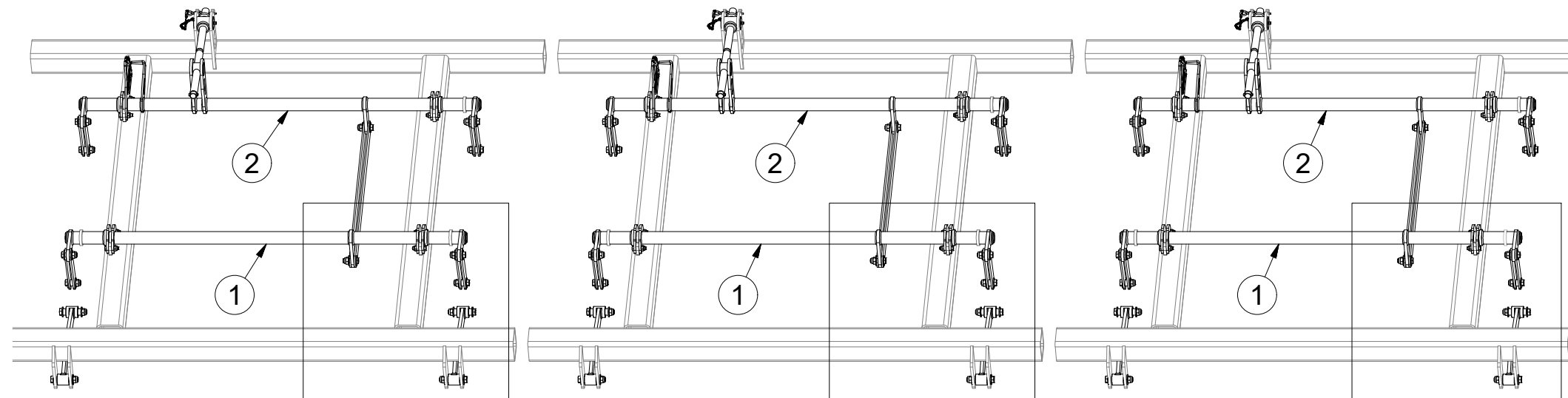

Pos.	Part Number	Pcs.
1	3002830	3
2	3002831	3
3	8000990-30007	6
5	4005333	24
6	4005334	6
13	4002265	30
14	9001426	12
31	m04355	30
32	m07673	12
41	m03683	42
50	m05651	84

Ⓒ SADA OVLÁDÁNÍ RADLIC

Ⓓ STEUERSATZ PFLUGSCHAREN

Ⓕ KIT DE COMMANDE DES SOCS

**3005538**

Ⓖ SET OF PLOUGHSHARE CONTROL

Ⓡ КОМПЛЕКТ УПРАВЛЕНИЯ ЛАП

Ⓢ ZESTAW STEROWANIA RADLICAMI

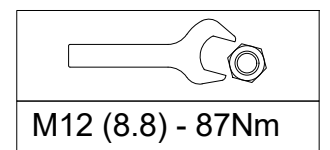
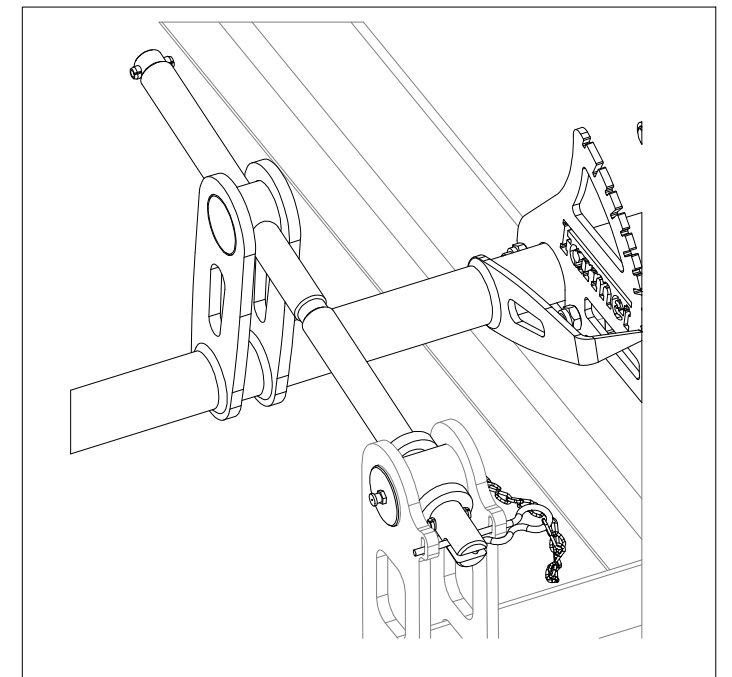
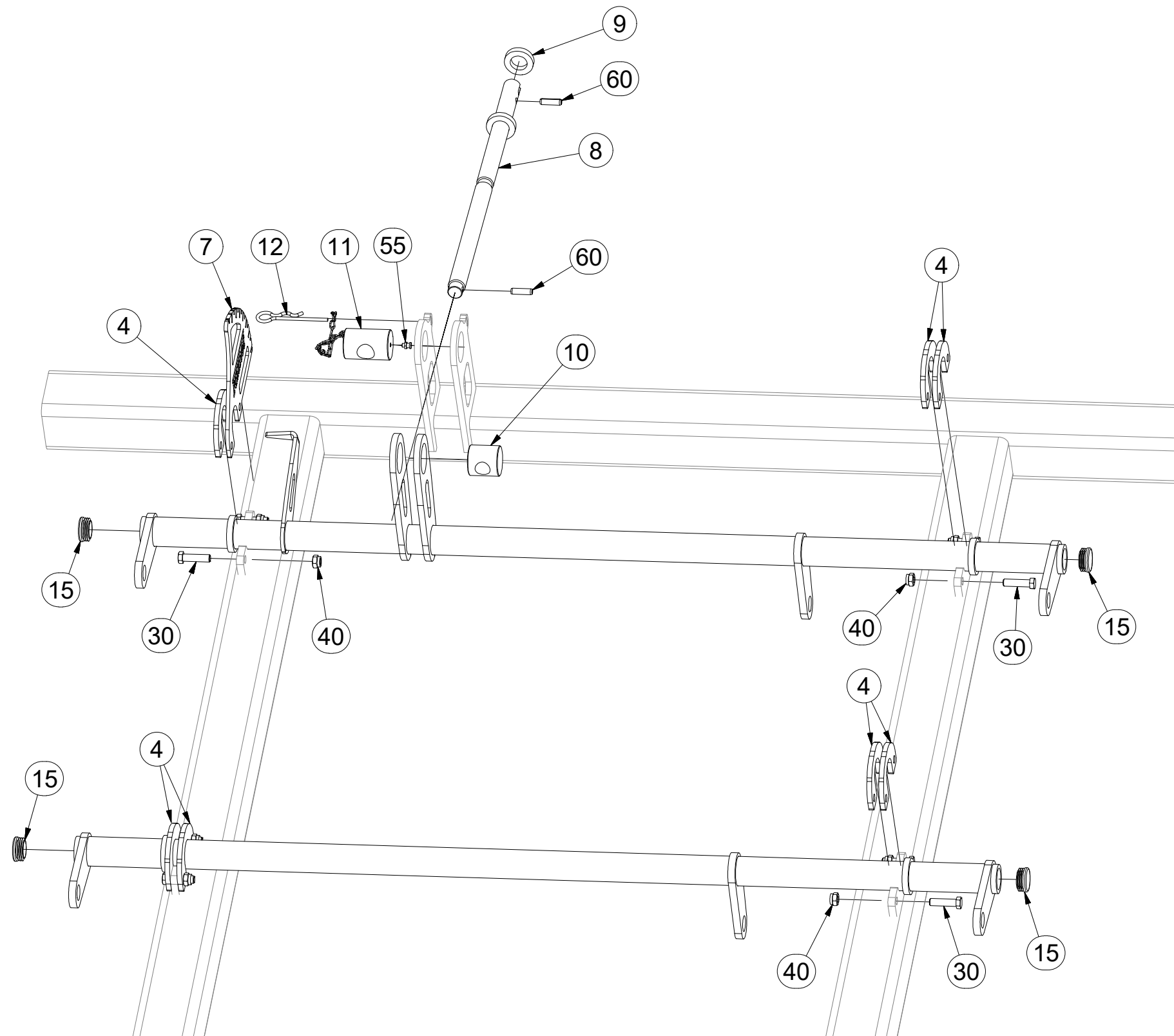

Pos.	Part Number	Pcs.
4	4005332	21
7	4005335	3
8	4007654	3
9	9002560	3
10	4005340	3
11	4005355	3
12	m09988	3
15	m10130	12
30	m06077	24
40	m04301	24
55	m10451	3
60	m10736	6

☉ SADA RADLIC

☐ SATZ PFLUGSCHAREN

☐ KIT DE SOCS

☉ SET OF PLOUGHSHARES

☐ КОМПЛЕКТ ЛАП

☐ ZESTAW REDLIC



**3002845**

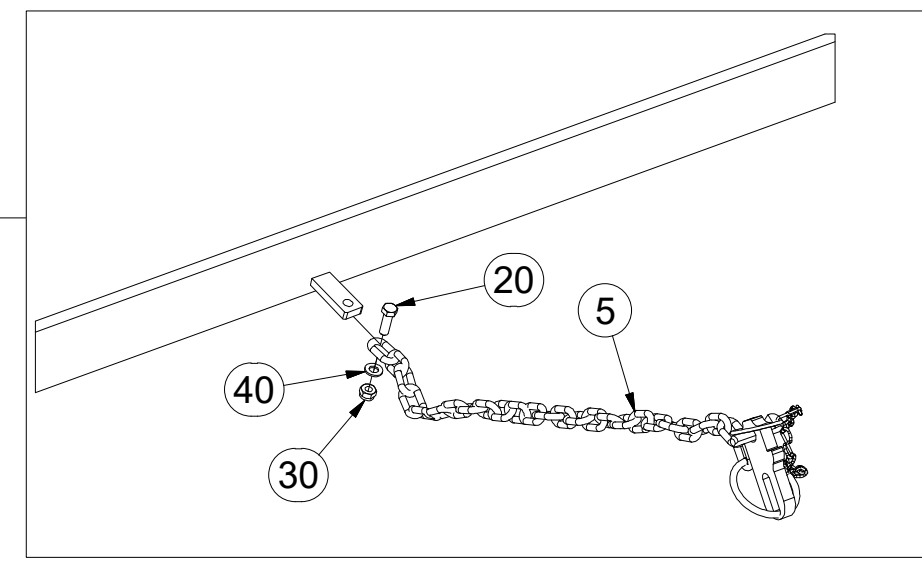
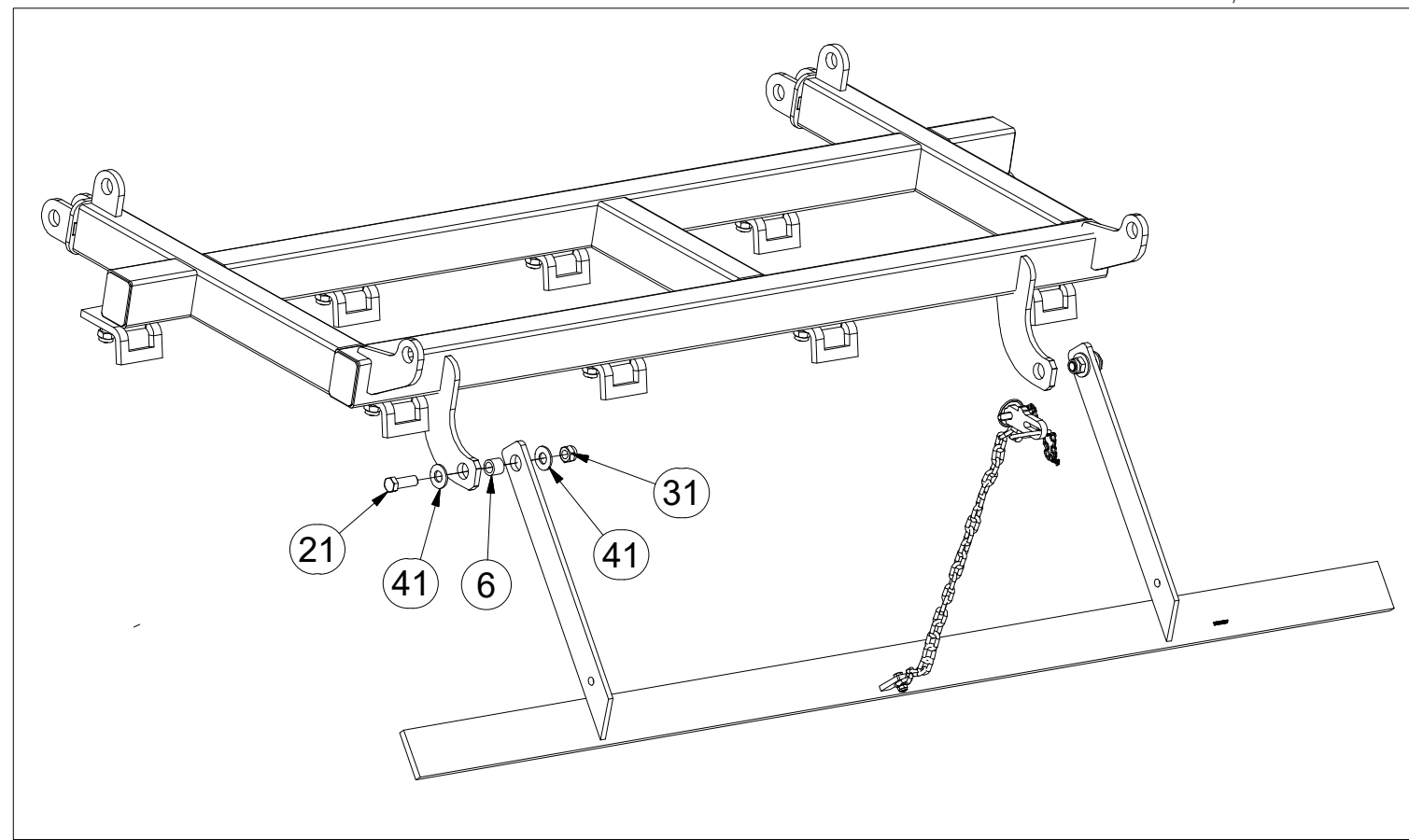
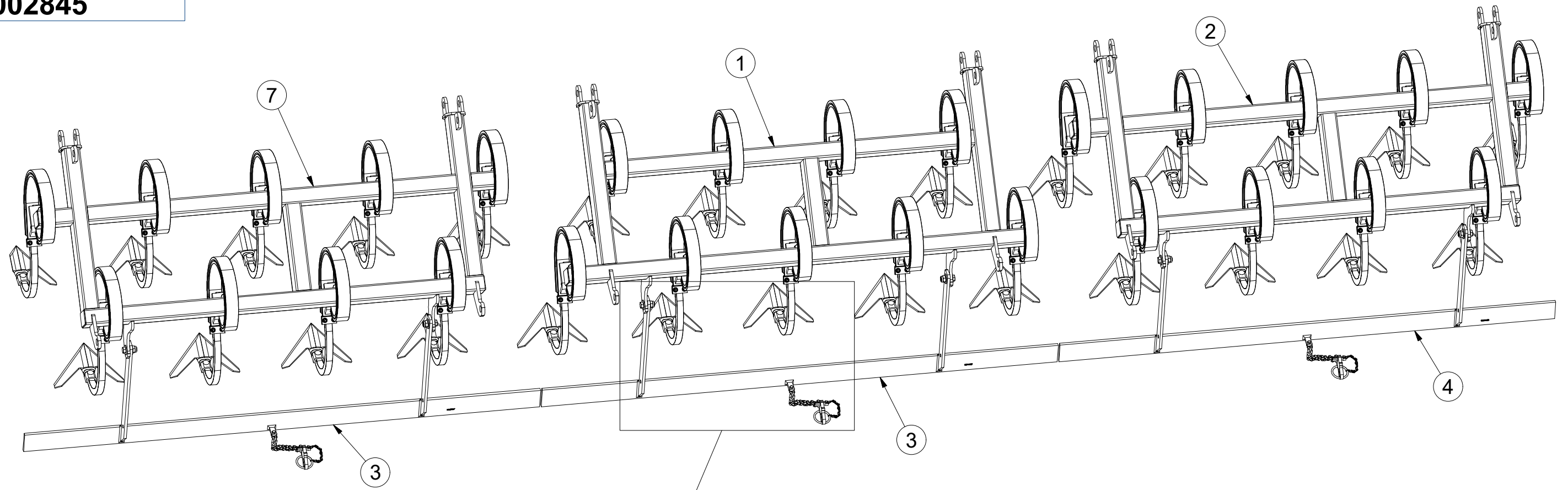

Pos.	Part Number	Pcs.
1	3002834	1
2	3007736	1
3	3002557	2
4	3002556	1
5	4001641	3
6	4004451	6
7	3007419	1
20	m01092	3
21	m02254	6
30	m04503	3
31	m03683	6
40	m01203	3
41	m05651	12



ⒸZ SADA RADLIC

Ⓓ SCHARSATZ

Ⓕ KIT DE SOCS

ⒼB SET OF PLOUGHSHARES

ⒺU КОМПЛЕКТ ЛАП

ⒽL ZESTAW REDLIC



**3002834**

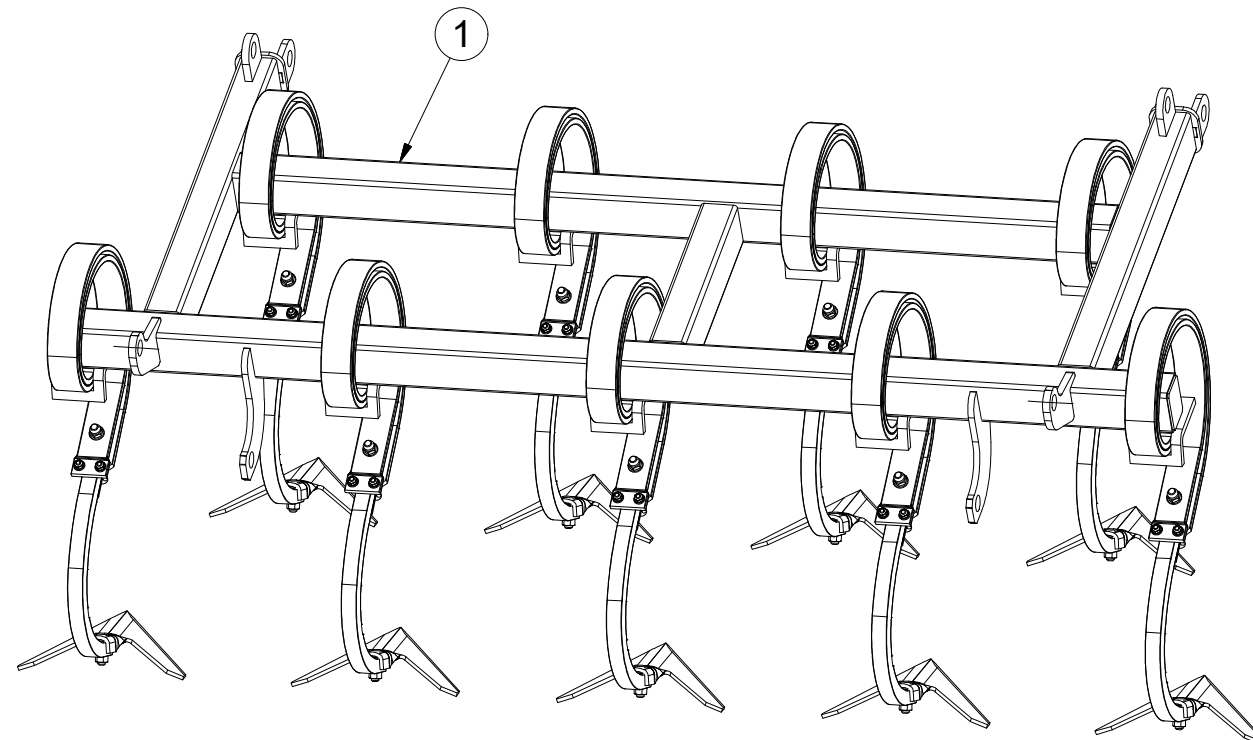
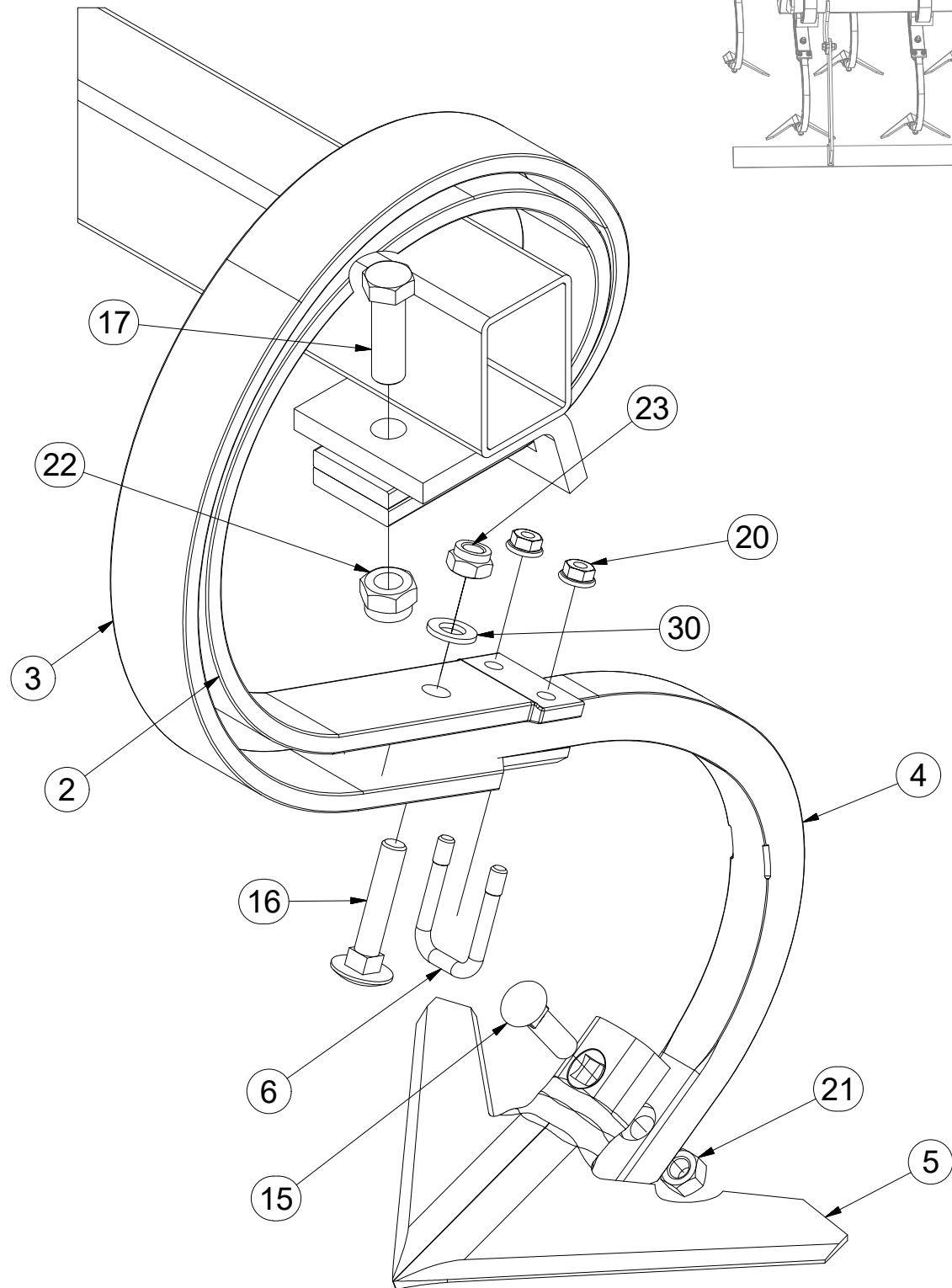
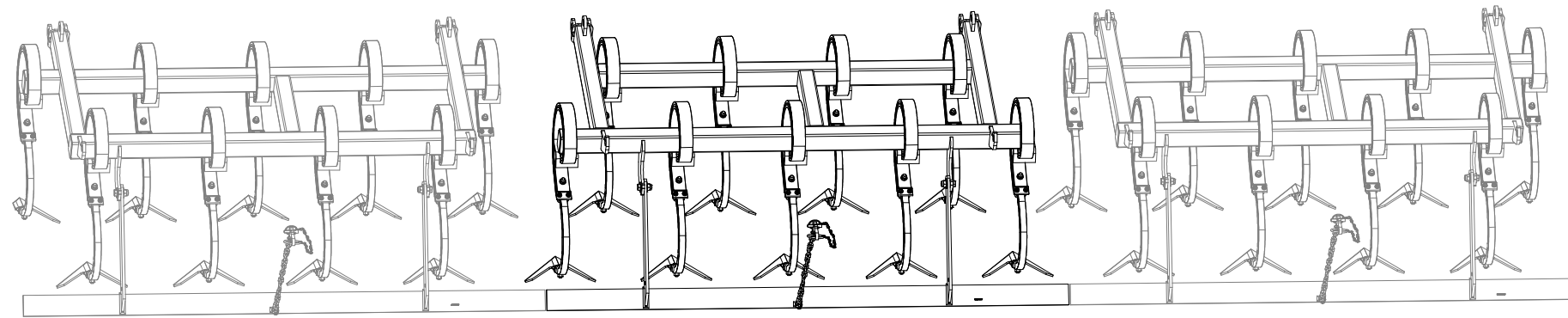

Pos.	Part Number	Pcs.
1	2000363	1
2	3000300	9
3	3000301	9
4	3002818	9
5	3000236-KOO	9
6	m09995	9
15	m10440	9
16	m11600	9
17	m04355	9
20	m06156	18
21	m10439	9
22	m03683	9
23	m04301	9
30	m01214	9

Ⓒ SADA RADLIC

Ⓓ SCHARSATZ

Ⓕ KIT DE SOCS

**3007419**

Ⓖ SET OF PLOUGHSHARES

Ⓡ КОМПЛЕКТ ЛАП

Ⓢ ZESTAW REDLIC

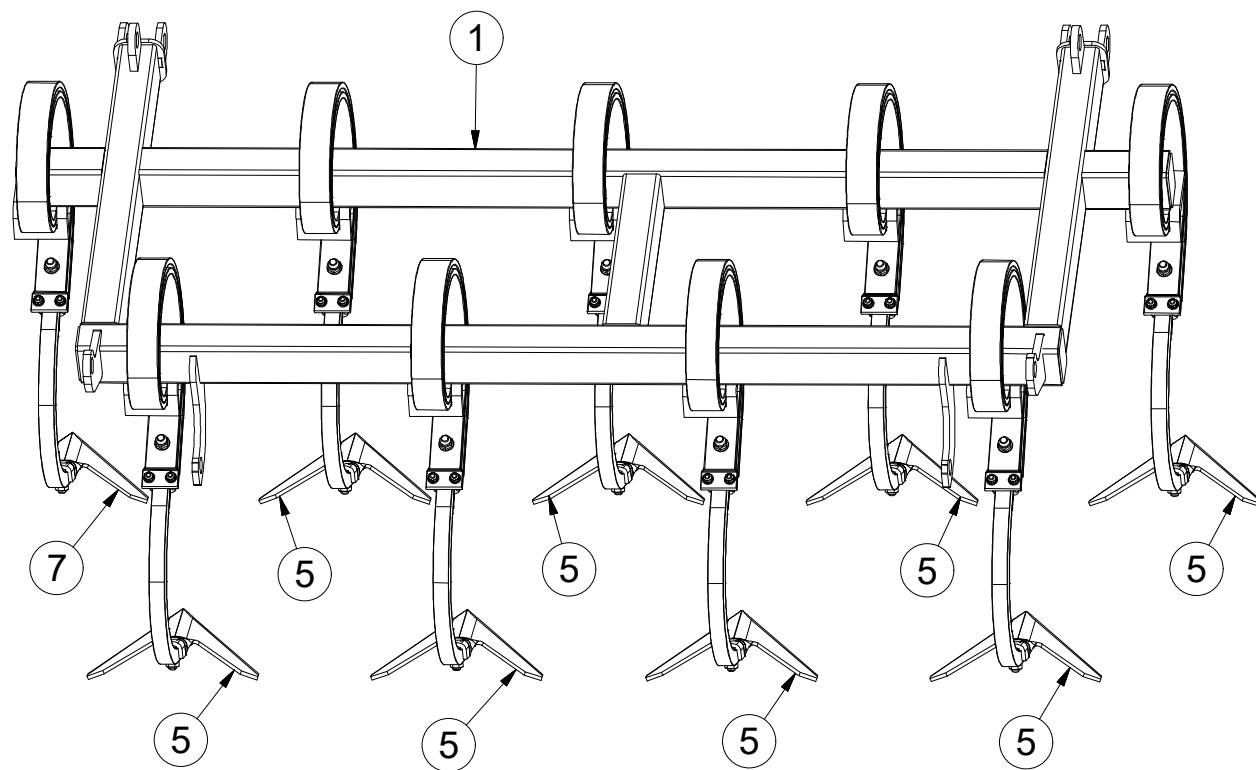
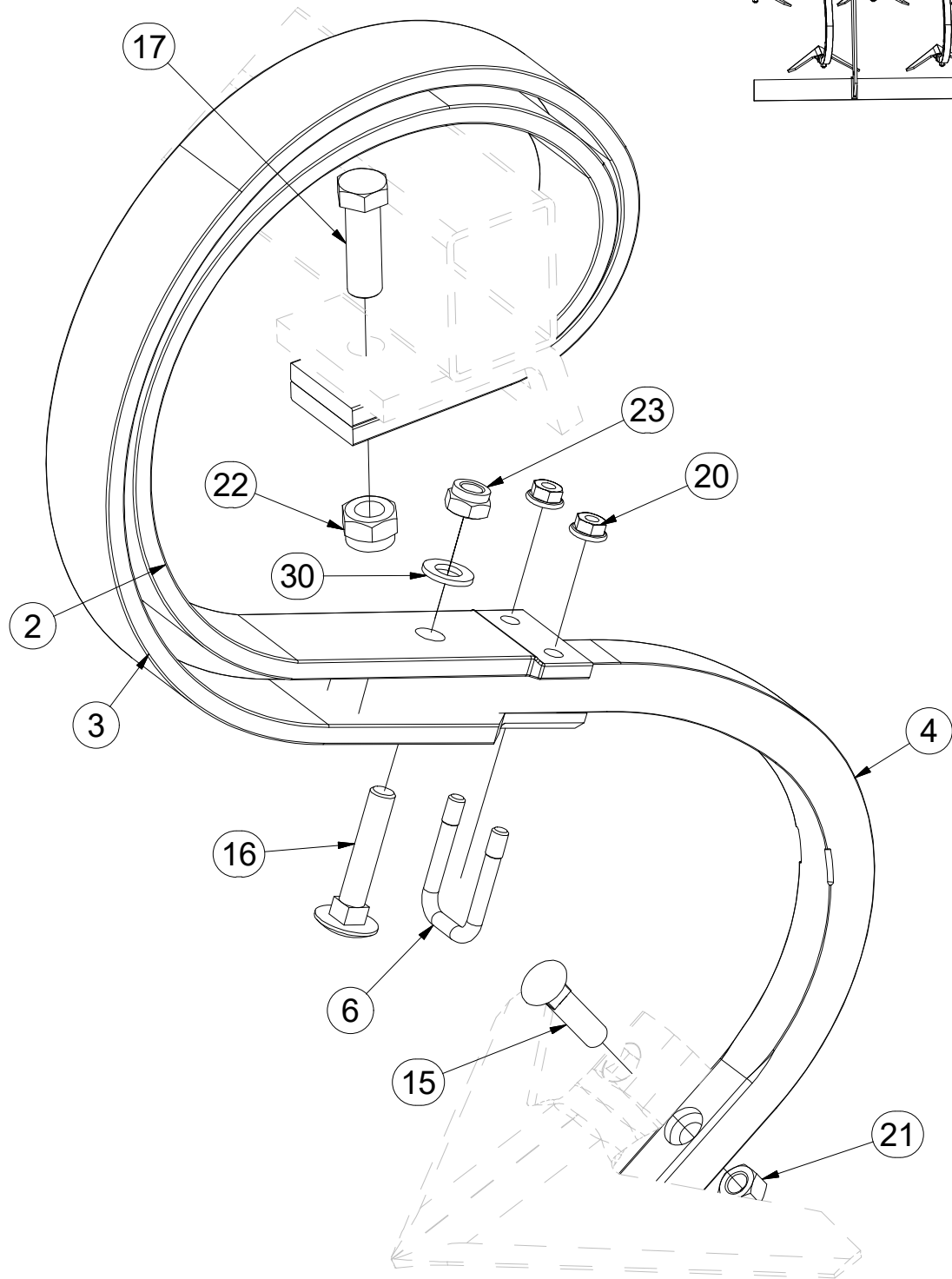
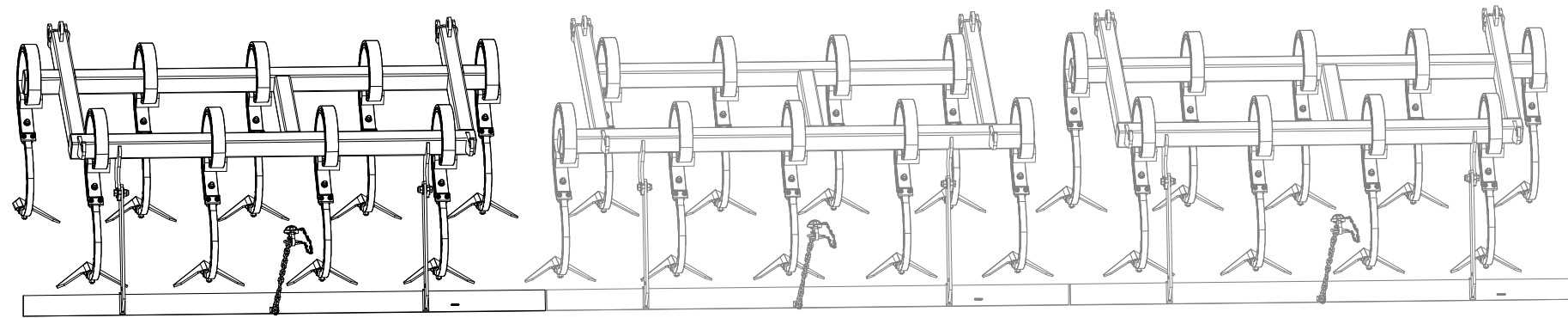

Pos.	Part Number	Pcs.
1	2000364	1
2	3000300	9
3	3000301	9
4	3002818	9
5	3000236-KOO	8
6	m09995	9
7	4007280	1
15	m10440	9
16	m11600	9
17	m04355	9
20	m06156	18
21	m10439	9
22	m03683	9
23	m04301	9
30	m01214	9

ⒸZ SADA RADLIC

Ⓓ SCHARSATZ

Ⓕ KIT DE SOCS

**3007736**

ⒼB SET OF PLOUGHSHARES

ⒺU КОМПЛЕКТ ЛАП

ⒽL ZESTAW REDLIC

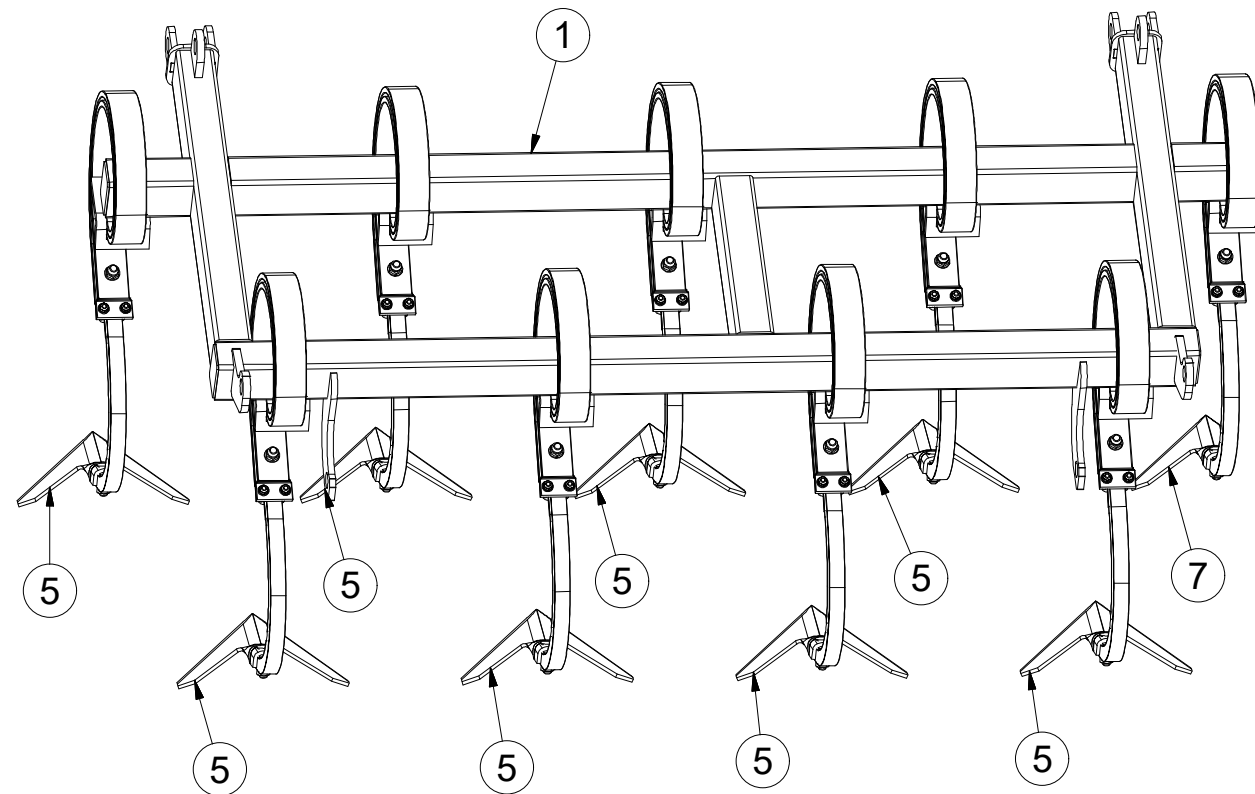
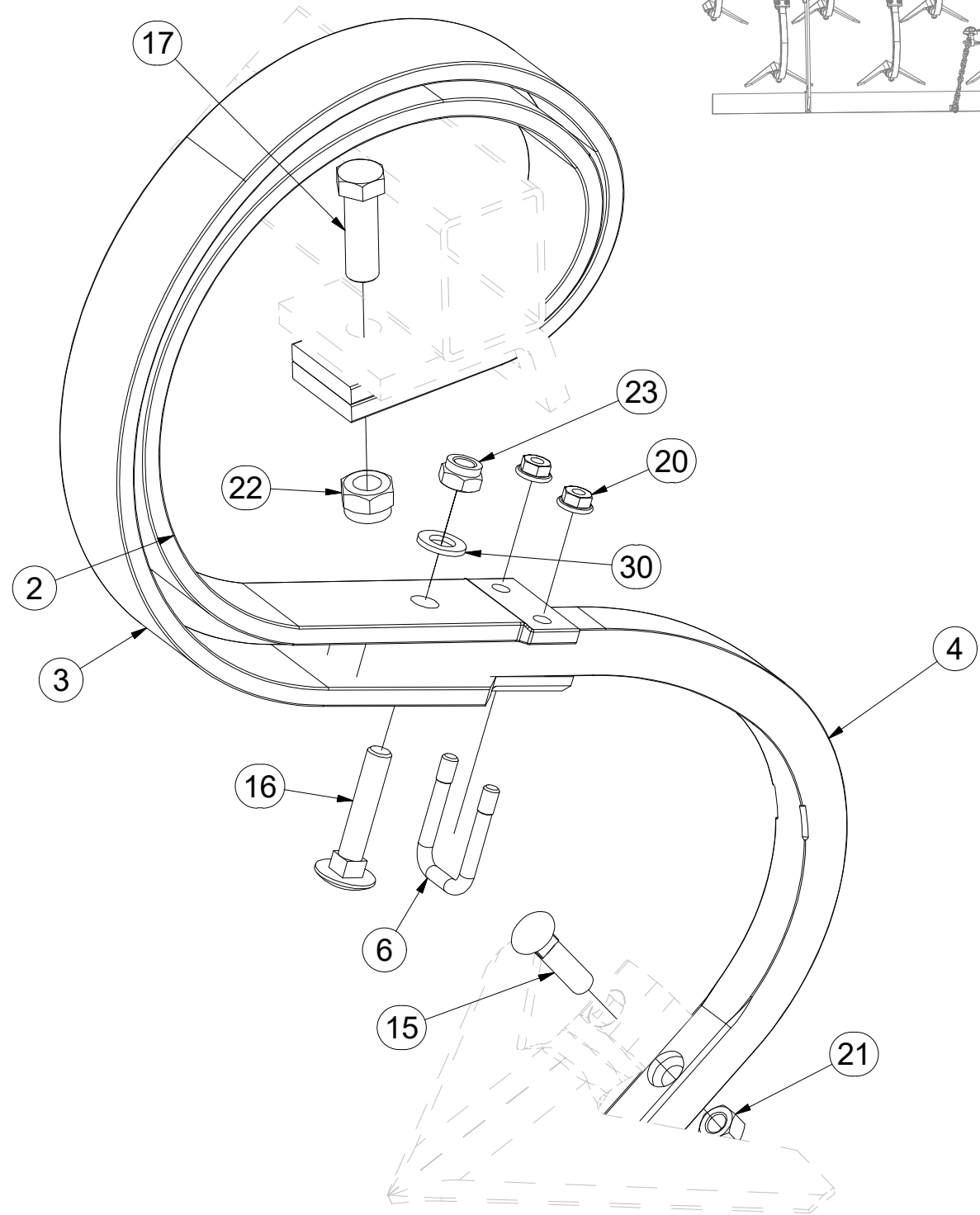
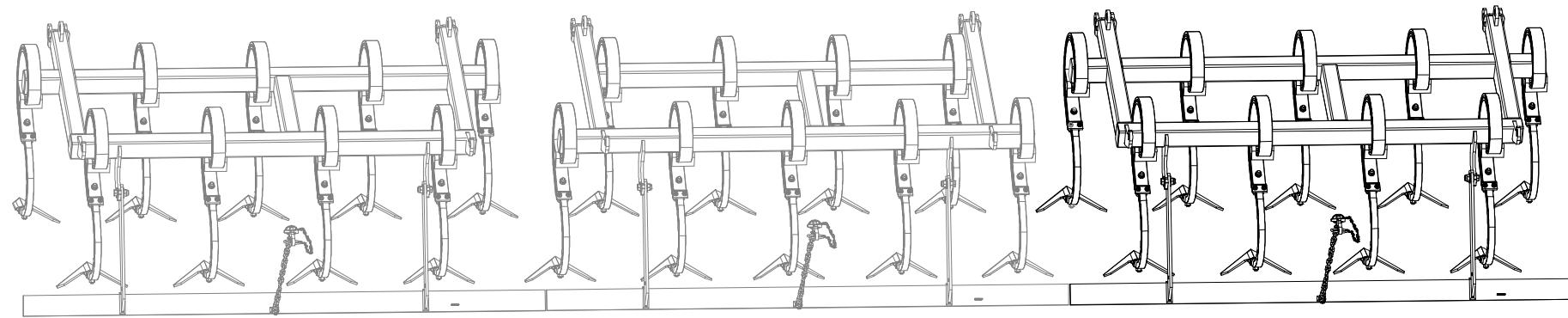

Pos.	Part Number	Pcs.
1	2000364	1
2	3000300	9
3	3000301	9
4	3002818	9
5	3000236-KOO	8
6	m09995	9
7	4007281	1
15	m10440	9
16	m11600	9
17	m04355	9
20	m06156	18
21	m10439	9
22	m03683	9
23	m04301	9
30	m01214	9

- Ⓒ SADA ZADNÍCH VÁLCŮ
- Ⓓ SATZ HINTERE WALZEN
- Ⓕ KIT DE ROULEAUX ARRIÈRE

- Ⓖ SET OF REAR ROLLERS
- Ⓡ КОМПЛЕКТ ЗАДНИХ КАТКОВ
- Ⓟ ZESTAW TYLNYCH WAŁÓW



**3004843**

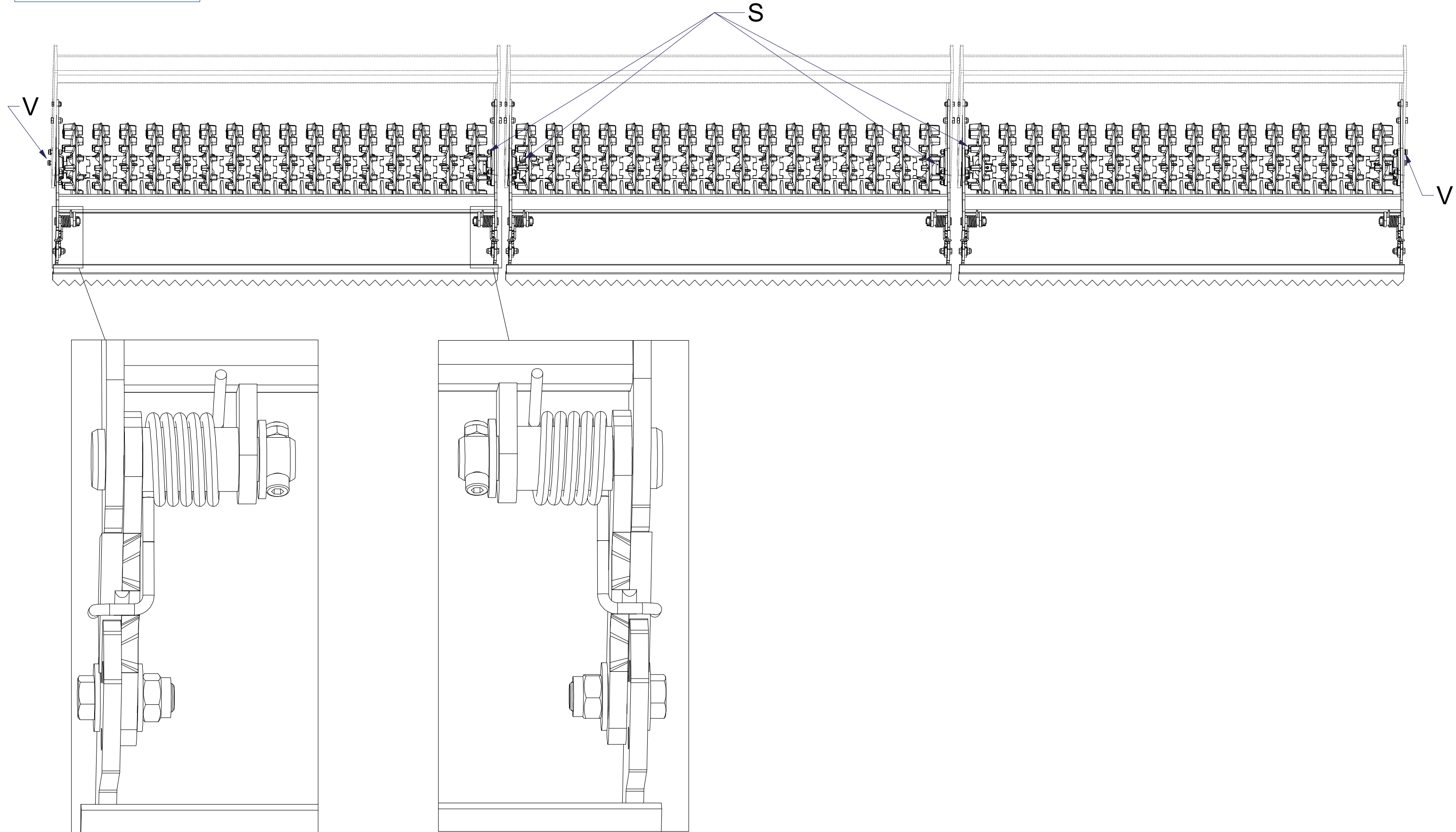

CZ SADA ZADNÍCH VÁLCŮ  
 D SATZ HINTERE WALZEN  
 F KIT DE ROULEAUX ARRIÈRE

GB SET OF REAR ROLLERS  
 RU КОМПЛЕКТ ЗАДНИХ КАТКОВ  
 PL ZESTAW TYLNYCH WAŁÓW



**3004843**

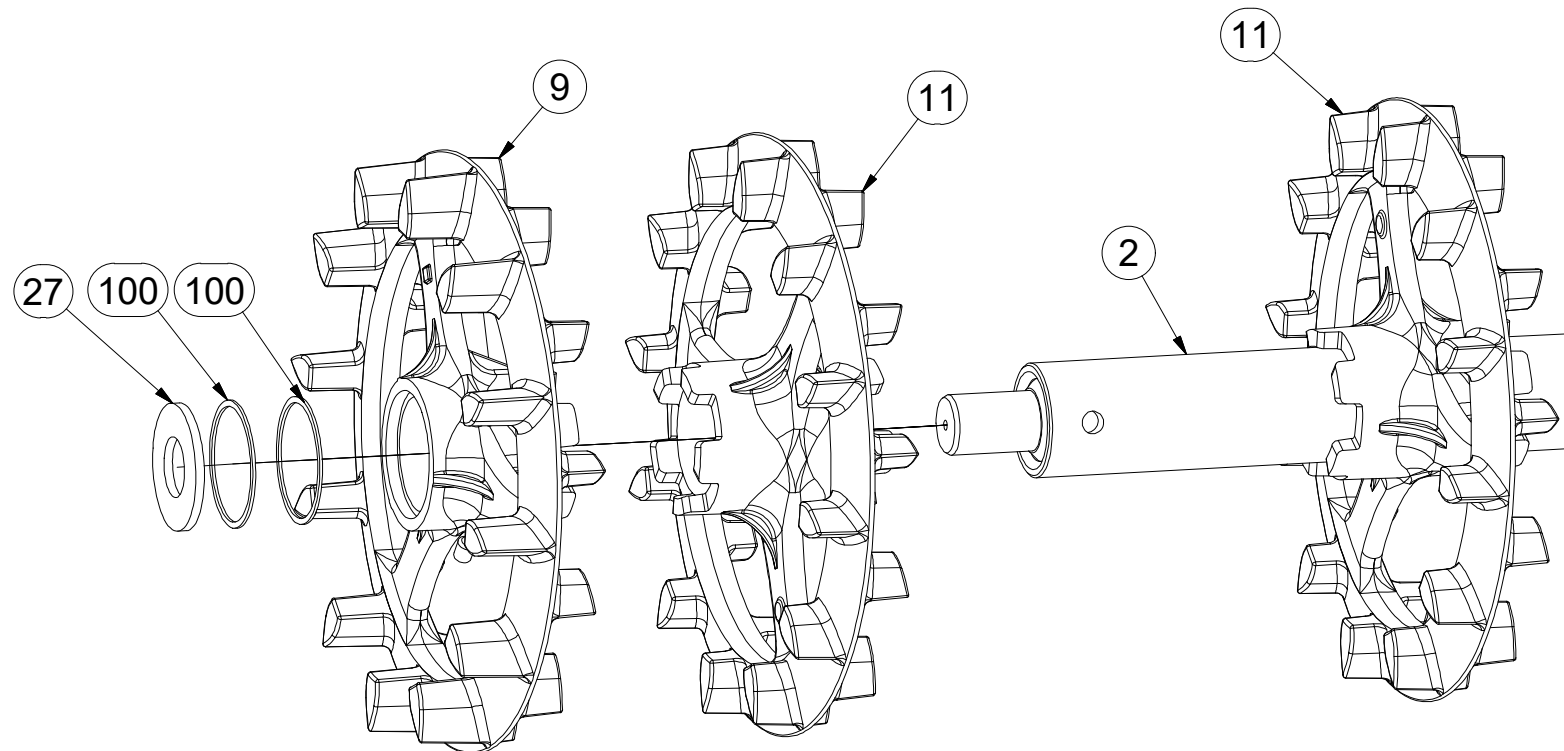
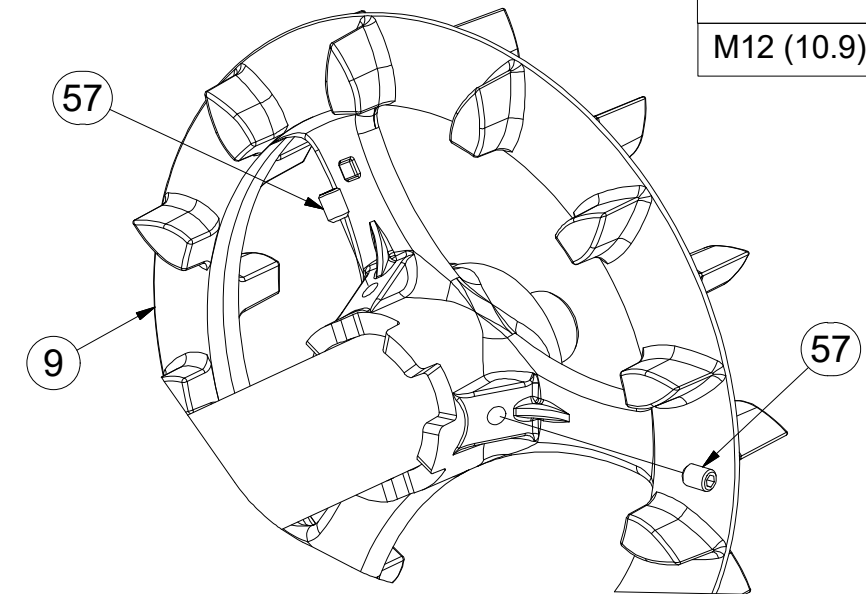
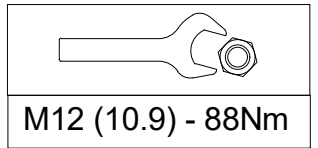
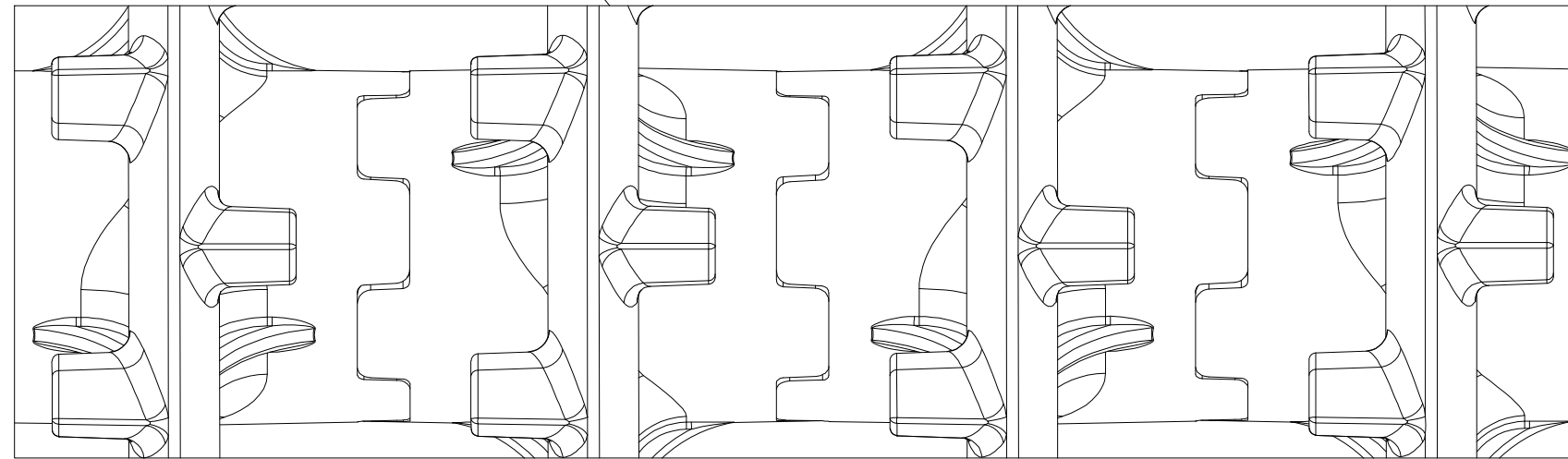
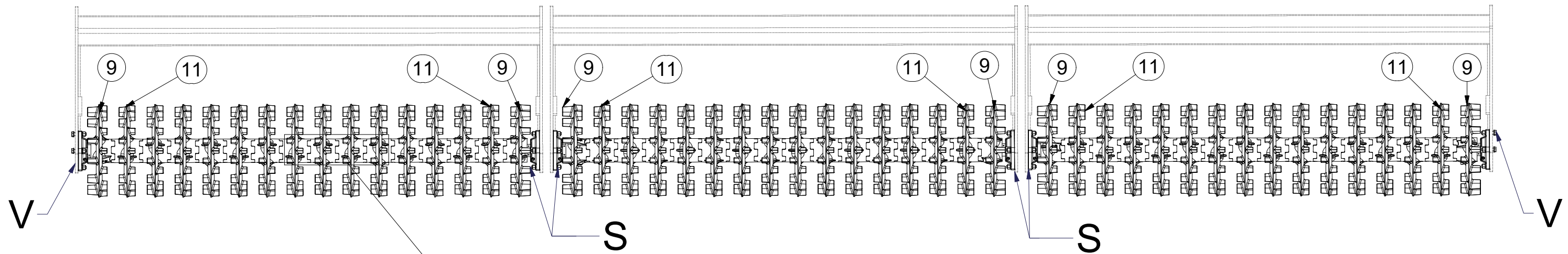

Pos.	Part Number	Pcs.
2	3001805	3
9	4009333	6
11	9002944	42
27	4016995	6
57	m13958	12
100	4010015	12

- Ⓒ SADA ZADNÍCH VÁLCŮ
- Ⓓ SATZ HINTERE WALZEN
- Ⓕ KIT DE ROULEAUX ARRIÈRE

- Ⓖ SET OF REAR ROLLERS
- Ⓡ КОМПЛЕКТ ЗАДНИХ КАТКОВ
- Ⓟ ZESTAW TYLNYCH WAŁÓW



**3004843**

S

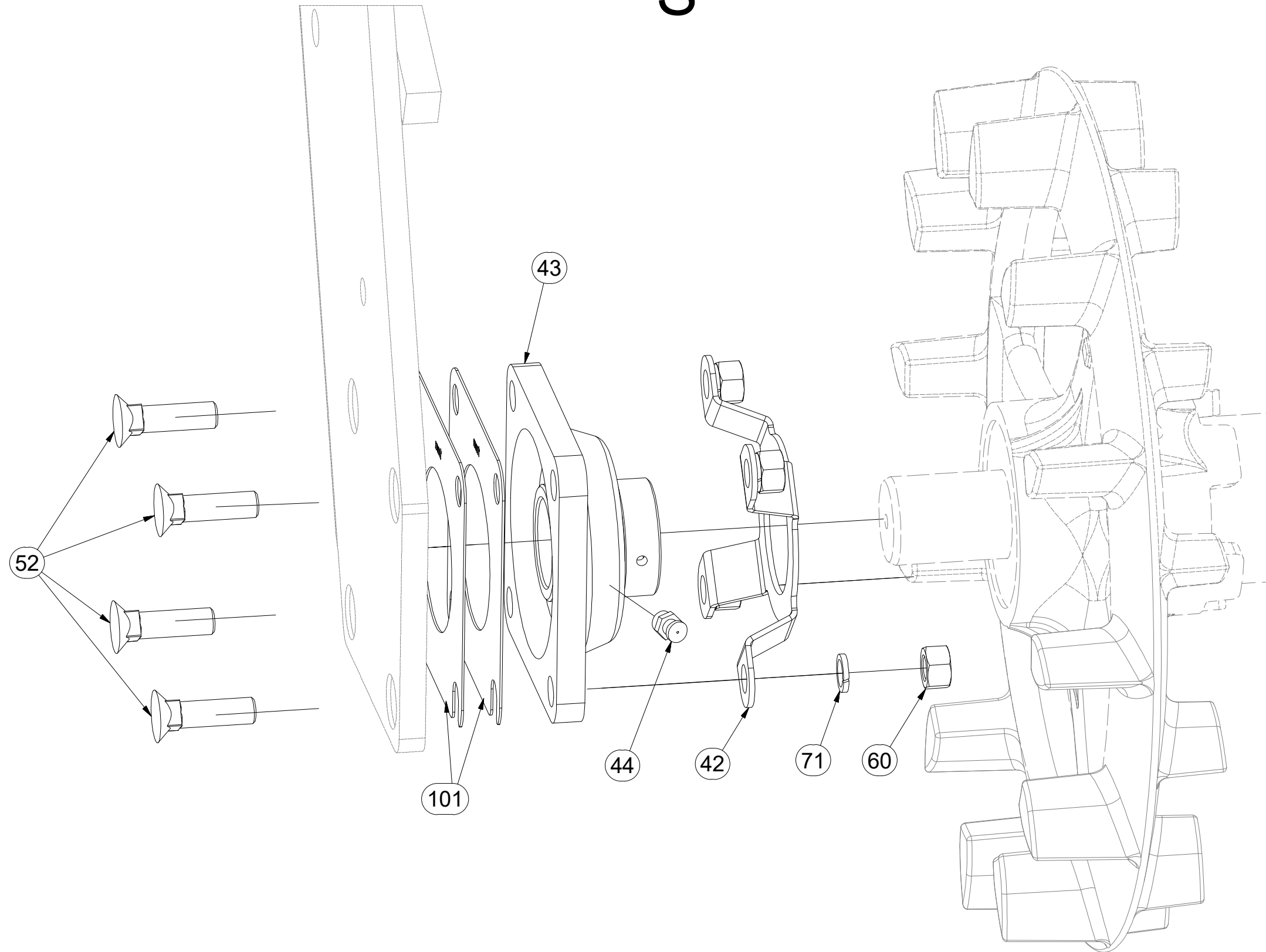

M12 (8.8) - 87Nm
KM10 - 15Nm

Pos.	Part Number	Pcs.
42	m12337	6
43	m09687	6
44	m10448	6
52	m03519	20
60	m01305	24
71	m03988	24
101	4016809	12

- Ⓒ SADA ZADNÍCH VÁLCŮ
- Ⓓ SATZ HINTERE WALZEN
- Ⓕ KIT DE ROULEAUX ARRIÈRE

- Ⓖ SET OF REAR ROLLERS
- Ⓡ КОМПЛЕКТ ЗАДНИХ КАТКОВ
- Ⓟ ZESTAW TYLNYCH WAŁÓW



**3004843**



M12 (8.8) - 87Nm  
KM10 - 15Nm

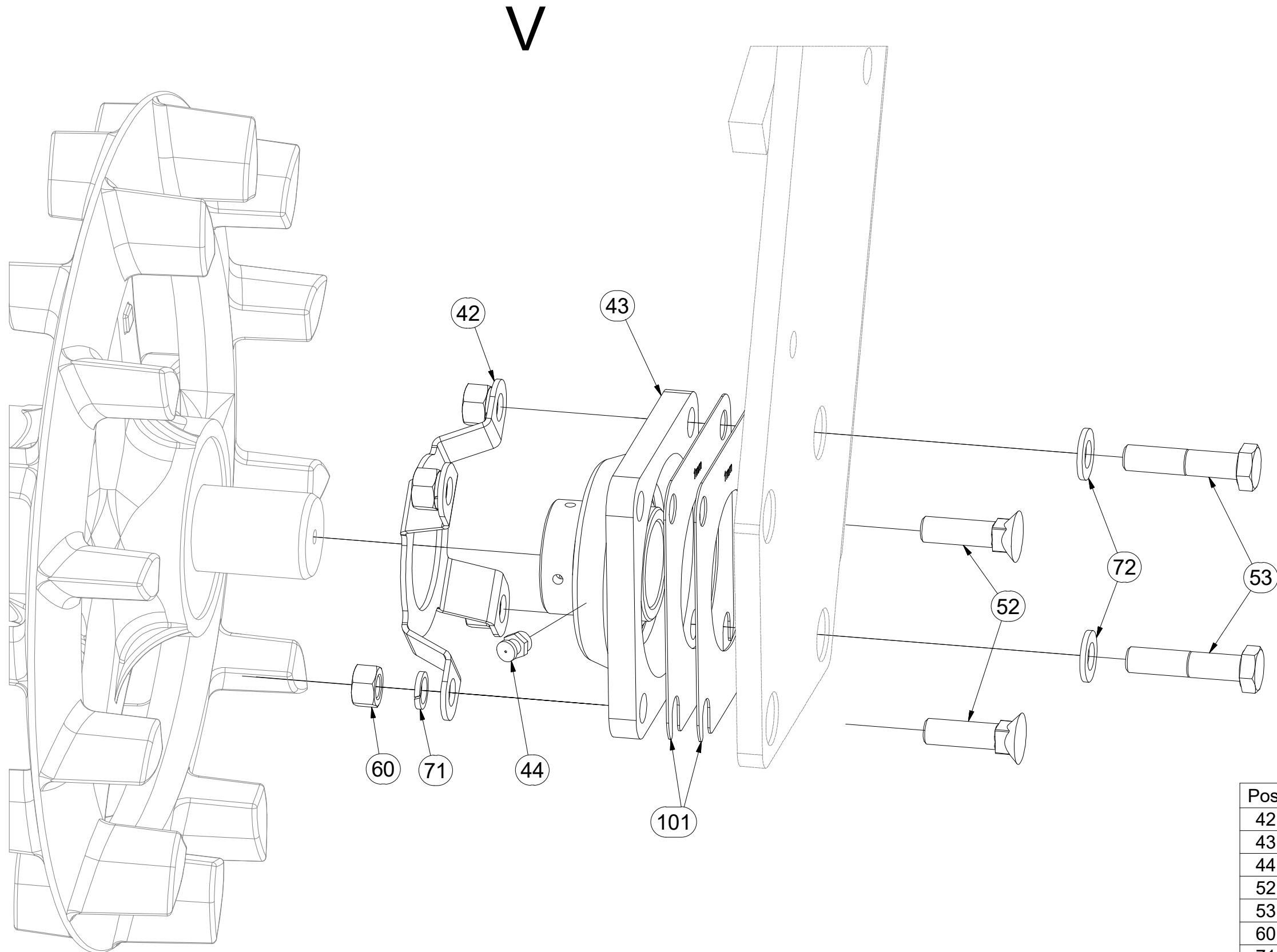

Pos.	Part Number	Pcs.
42	m12337	6
43	m09687	6
44	m10448	6
52	m03519	20
53	m04412	4
60	m01305	24
71	m03988	24
72	m01214	4
101	4016809	12

- Ⓒ SADA ZADNÍCH VÁLCŮ
- Ⓓ SATZ HINTERE WALZEN
- Ⓕ KIT DE ROULEAUX ARRIÈRE

- Ⓖ SET OF REAR ROLLERS
- Ⓡ КОМПЛЕКТ ЗАДНИХ КАТКОВ
- Ⓟ ZESTAW TYLNYCH WAŁÓW



**3004843**

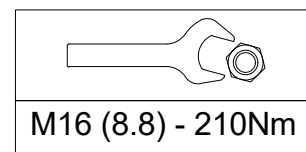
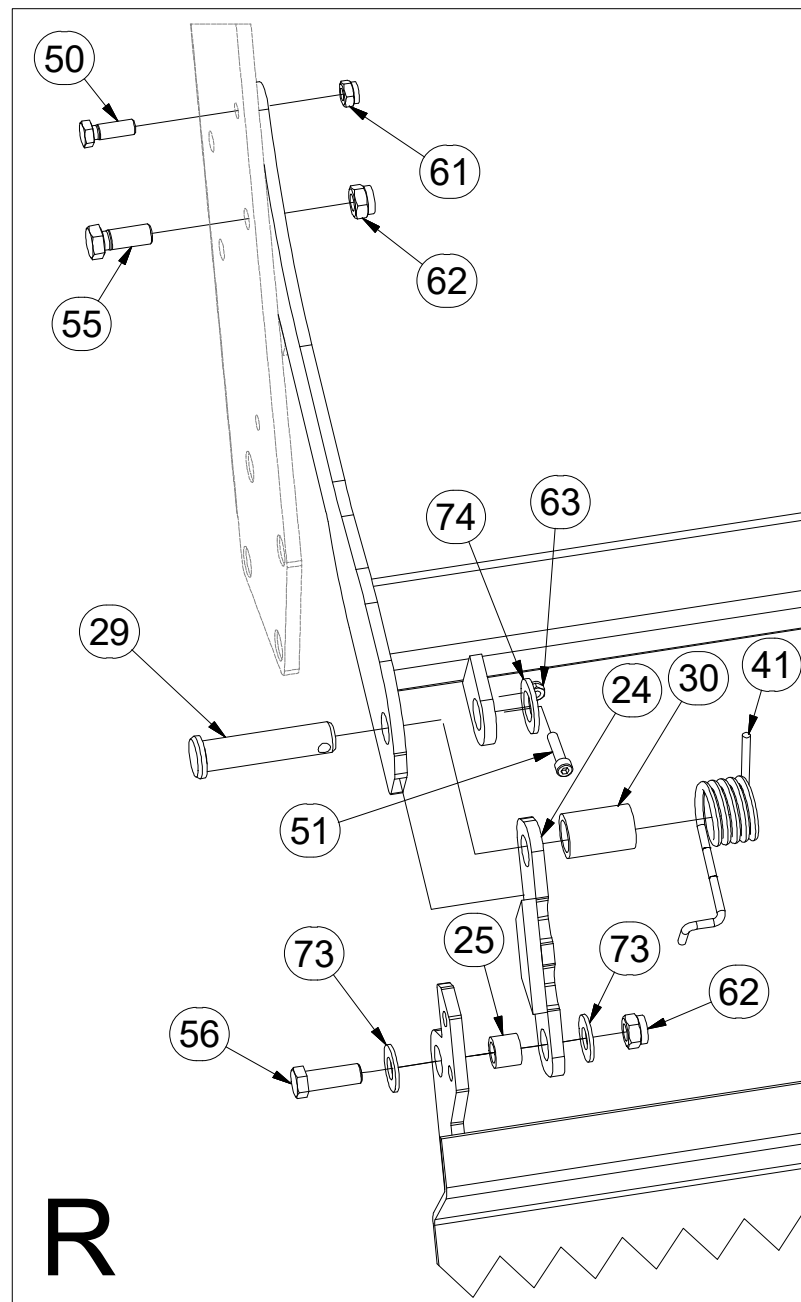
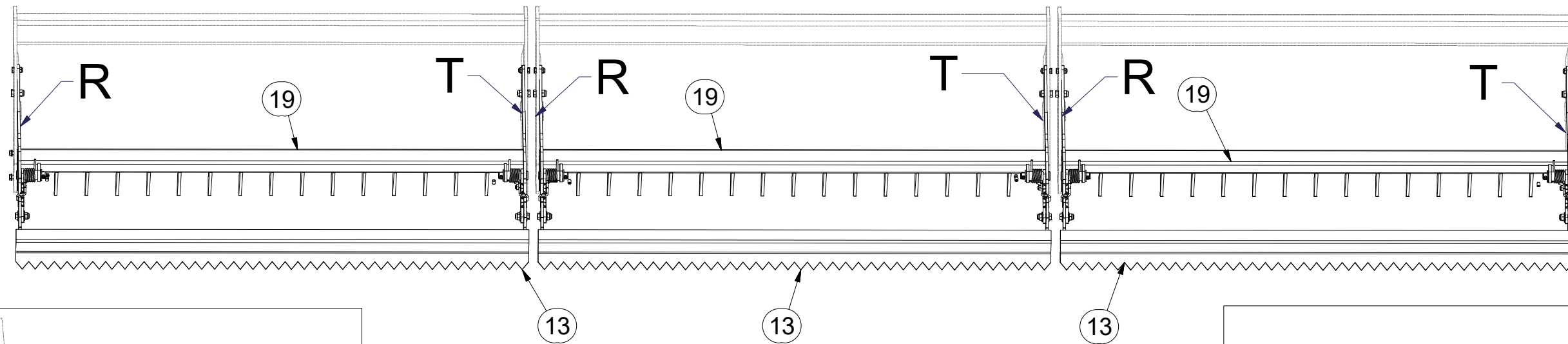

Pos.	Part Number	Pcs.
13	3001672	3
19	3004896	3
24	4002269	6
25	4004451	6
29	4015778	6
30	9002979	6
40	m12303	3
41	m12304	3
50	m04343	6
51	m09464	6
55	m01129	6
56	m02254	6
61	m04301	6
62	m03683	12
63	m04503	6
73	m05651	12
74	m14028	6

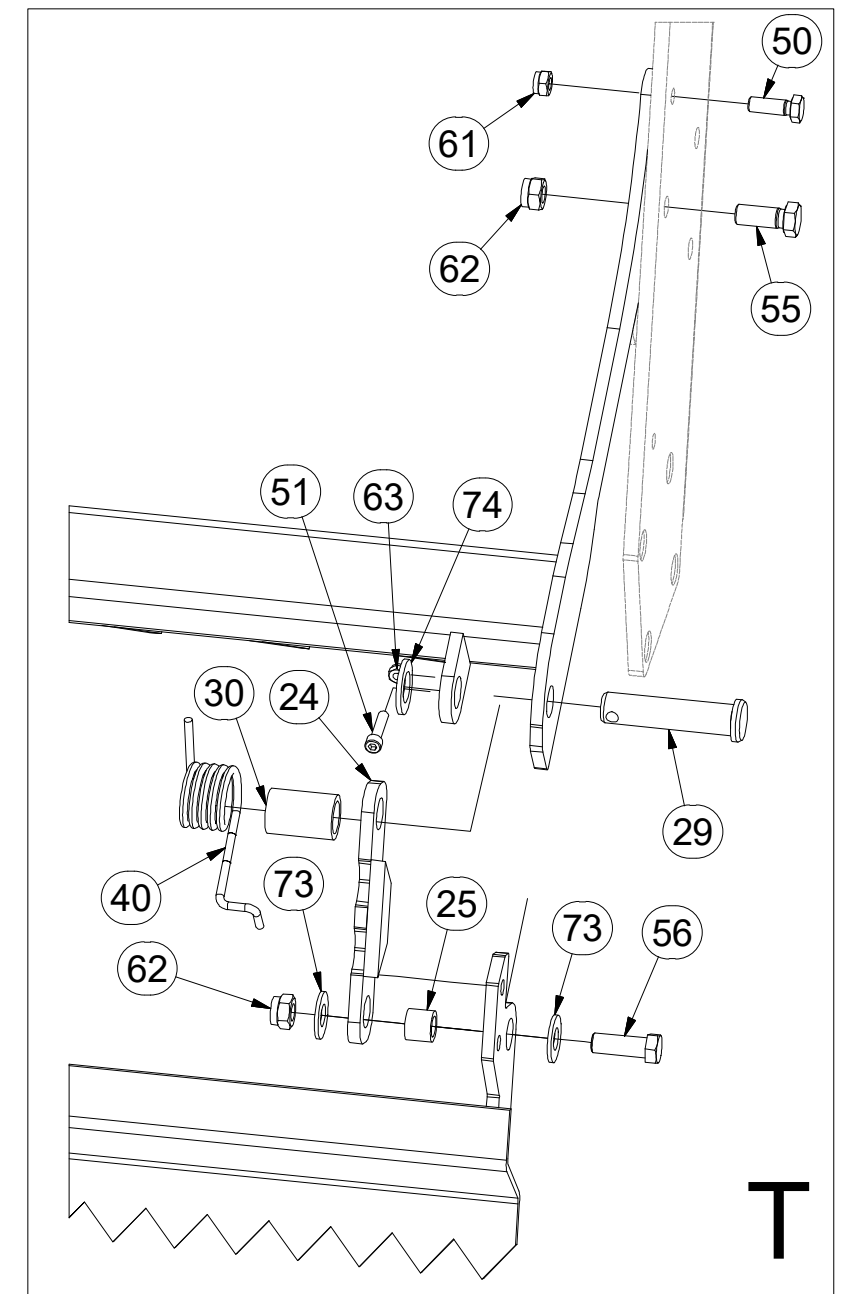



ⒸZ SADA DORAZŮ ZADNÍCH SMYKŮ

Ⓓ ANSCHLAGSATZ FÜR HINTERE ACKERSCHLEPPEN

Ⓕ KIT DE BUTÉES DES NIVELEURS ARRIÈRE

ⒼB SET OF REAR LEVELLING BAR STOPS

ⒺU КОМПЛЕКТ УПОРОВ ЗАДНИХ БОРОН

ⒼL ZESTAW DOCISKÓW TYLNYCH WŁÓK



**3006133**

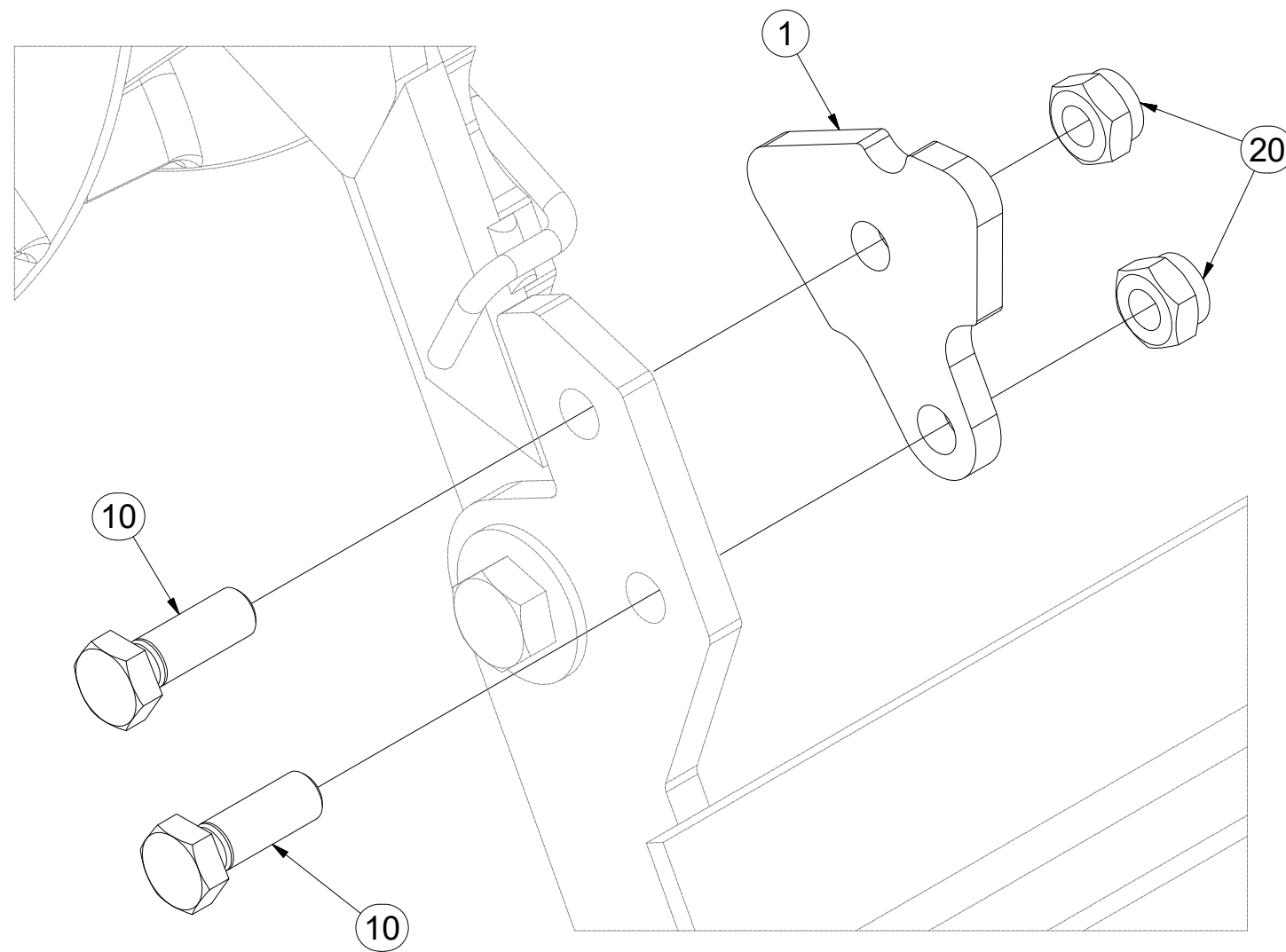
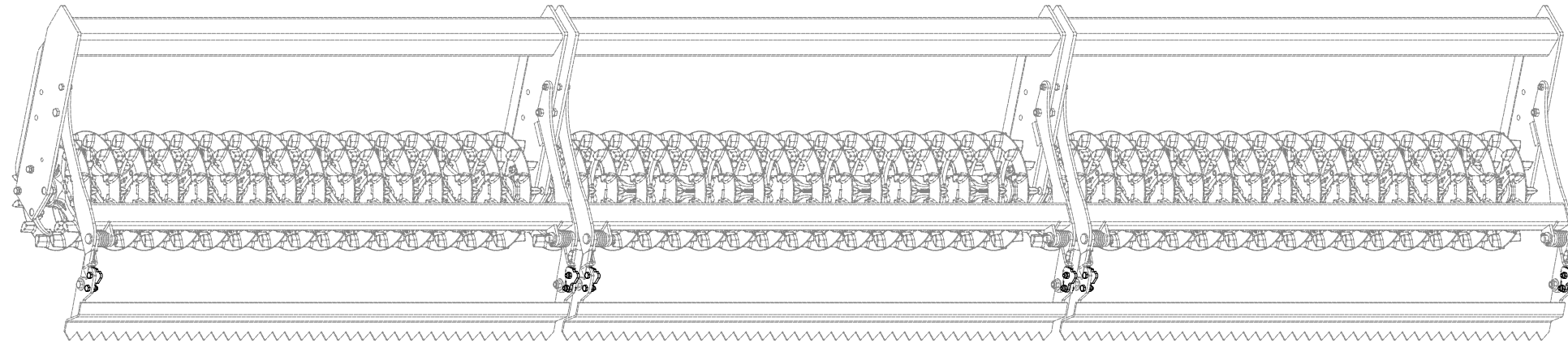
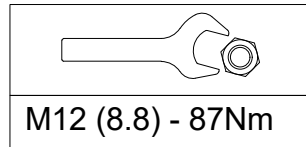

Pos.	Part Number	Pcs.
1	4009757	6
10	m04343	12
20	m04301	12

Ⓒ CZ SADA NÁPRAVY

Ⓓ D SATZ AUFHÄNGUNG

Ⓕ F KIT DE L'ESSIEU

Ⓖ GB AXLE SET

Ⓡ RU КОМПЛЕКТ ОСИ КОЛЁС

Ⓟ PL ZESTAW OSI

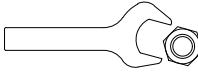

**3006164**

	400 kPa
	M18x1,5-265Nm
	
	M8 (8.8) - 25Nm
	M12 (8.8) - 87Nm

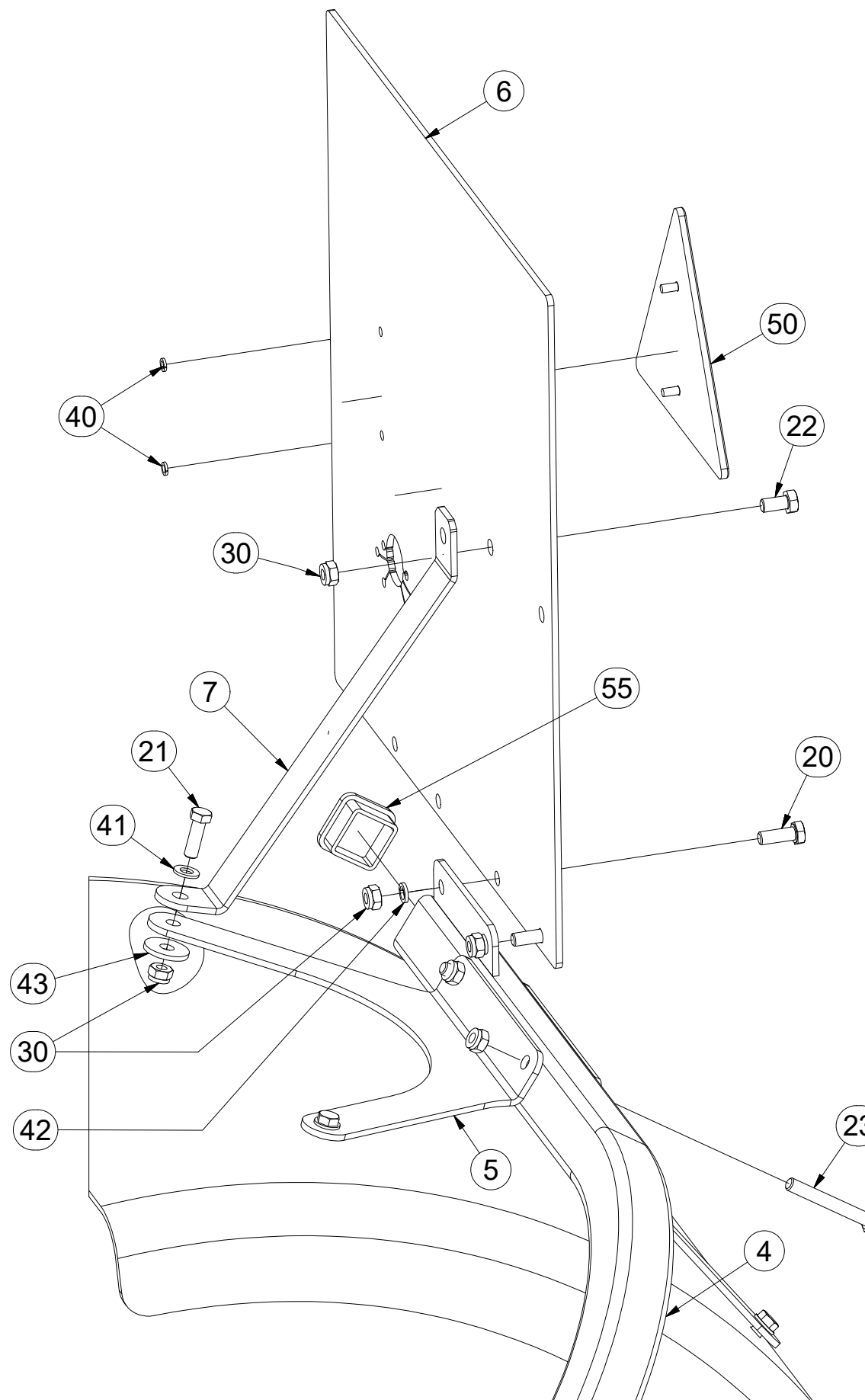
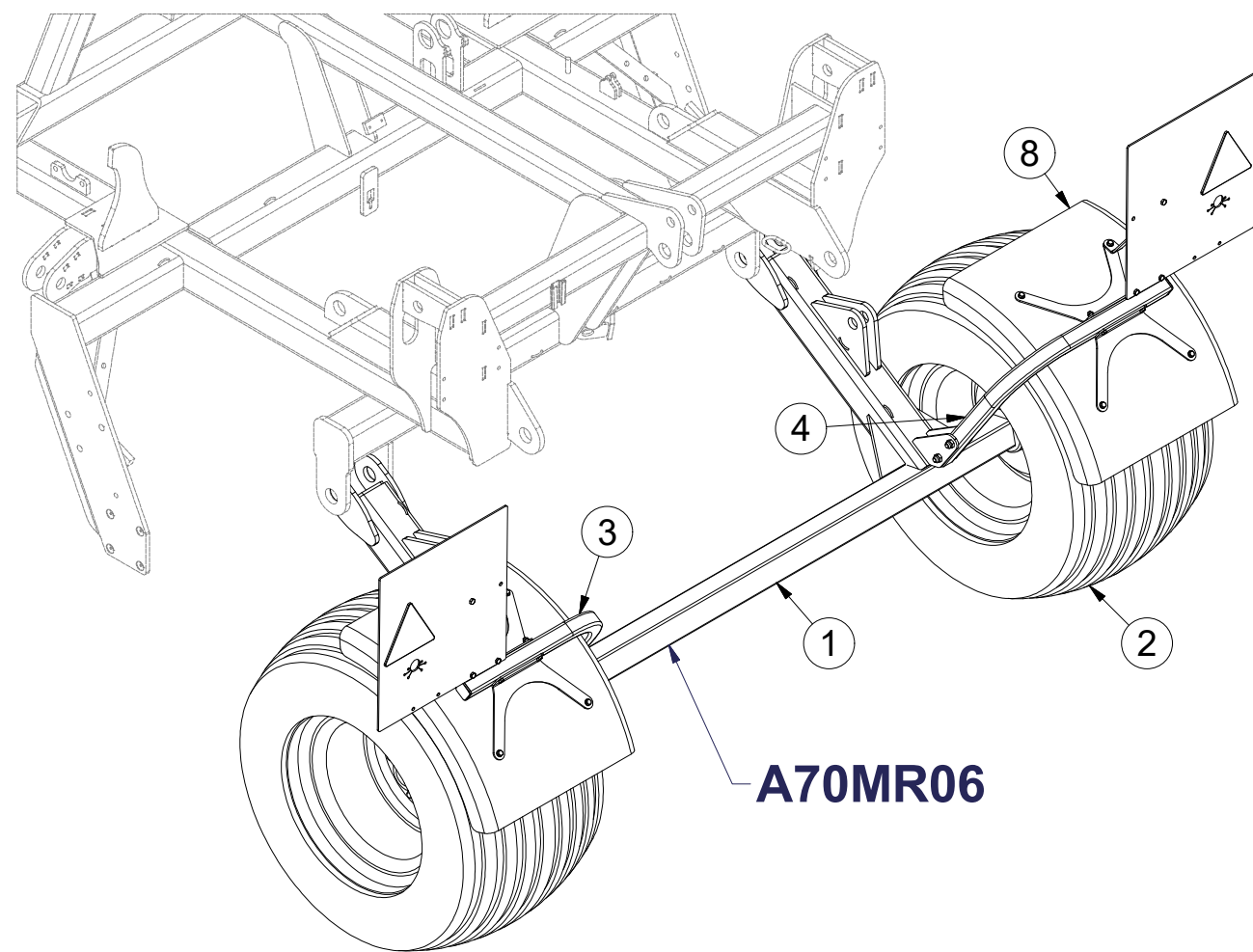
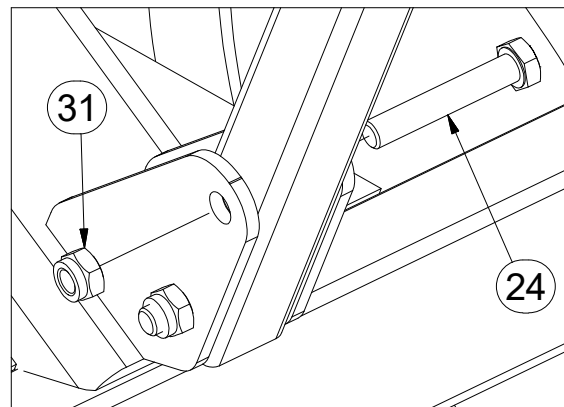

Pos.	Part Number	Pcs.
1	3007938	1
2	m11625	2
3	3007289	1
4	3007290	1
5	4014027	4
6	4014031	2
7	4014030	2
8	m09983	2
20	m01090	4
21	m01092	8
22	m04553	2
23	m14355	4
24	m14266	4
30	m04503	18
31	m04301	4
40	m01197	4
41	m01203	8
42	m01202	4
43	m07936	8
50	m02497	2
55	m12689	2

**m11625**

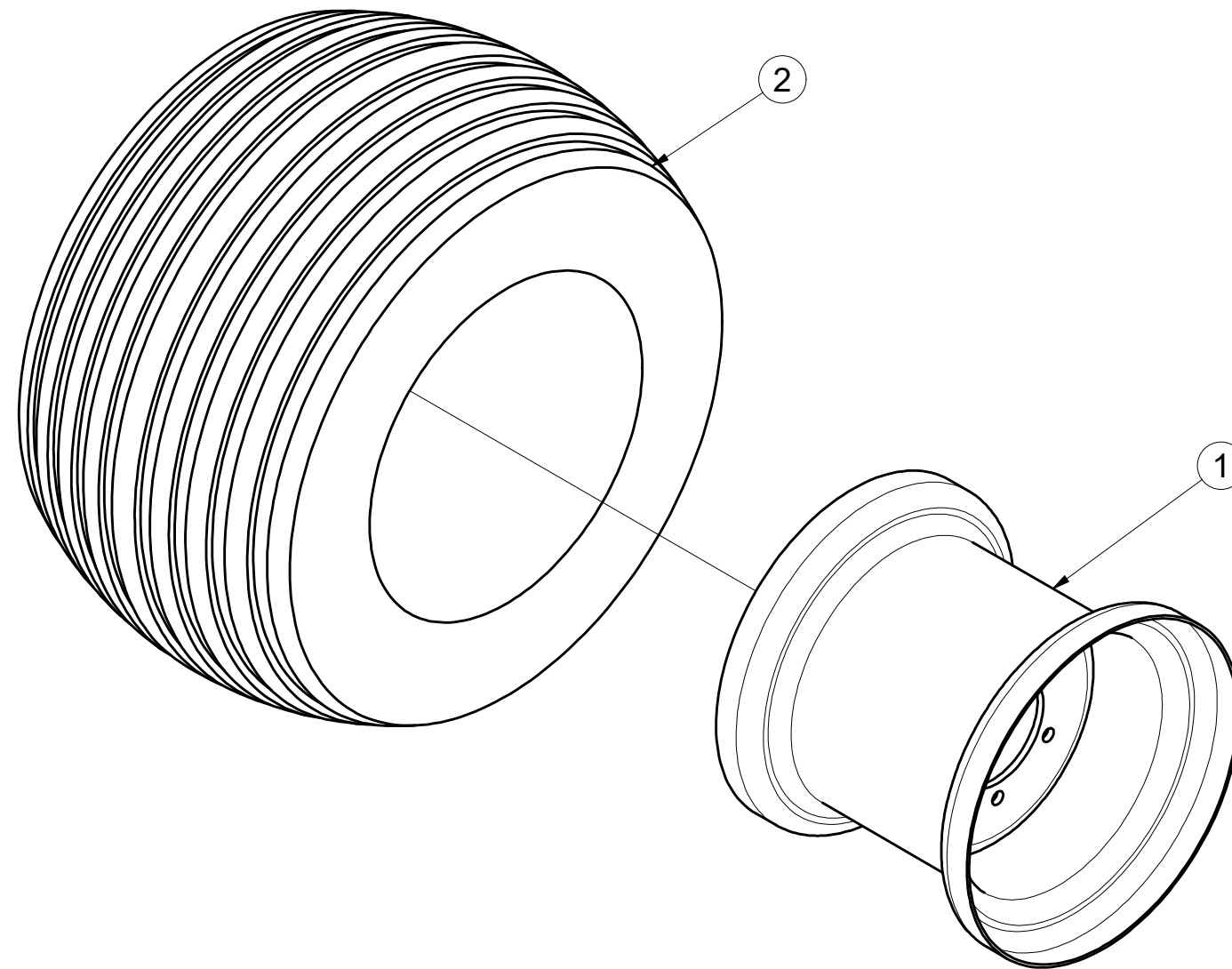

Pos.	Part Number	Pcs.
1	m08228	1
2	m07707	1

Ⓒ NÁPRAVA

Ⓓ ACHSE

Ⓕ ESSIEU

Ⓖ AXLE

Ⓡ OCB

Ⓟ OS



**A70MR06**

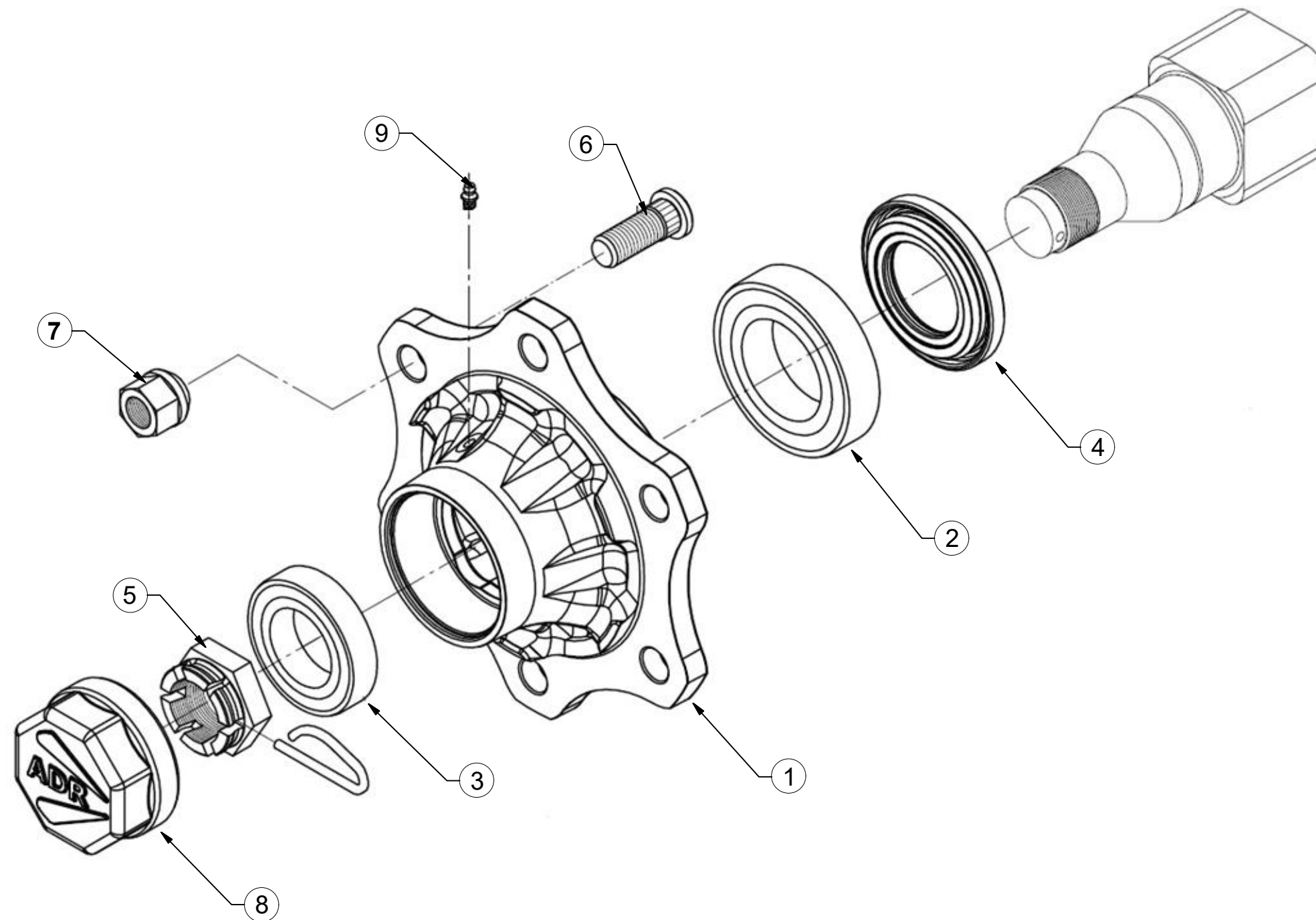

Pos	Part Number	Pcs.
1	m14910	2
2	m08194	2
3	m07152	2
4	m14924	2
5	m08169	2
6	m08148	12
7	m08163	12
8	m14923	2
9	m05698	2

Ⓒ SVĚTELNÁ SADA

Ⓓ LEUCHTENSATZ

Ⓕ KIT LUMINEUX

Ⓖ LIGHTING SET

Ⓡ ОСВЕТИТЕЛЬНЫЙ КОМПЛЕКТ

Ⓢ ZESTAW OŚWIETLENIA



**3008454**

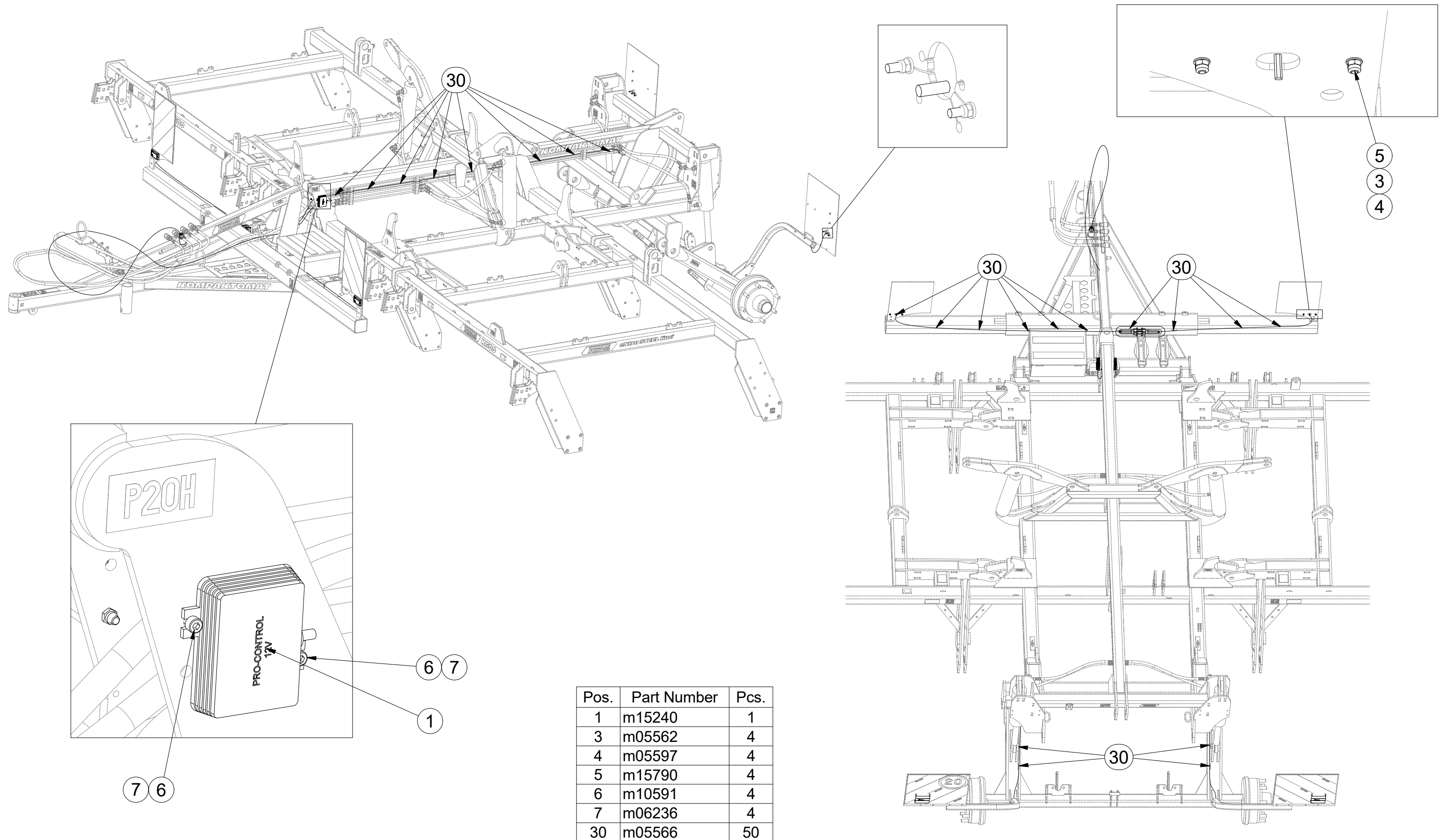

Pos.	Part Number	Pcs.
1	m15240	1
3	m05562	4
4	m05597	4
5	m15790	4
6	m10591	4
7	m06236	4
30	m05566	50

Ⓒ SVĚTELNÁ SADA

Ⓓ LEUCHTENSATZ

Ⓕ KIT LUMINEUX

Ⓖ LIGHTING SET

Ⓡ ОСВЕТИТЕЛЬНЫЙ КОМПЛЕКТ

Ⓢ ZESTAW OŚWIETLENIA



**3008454**

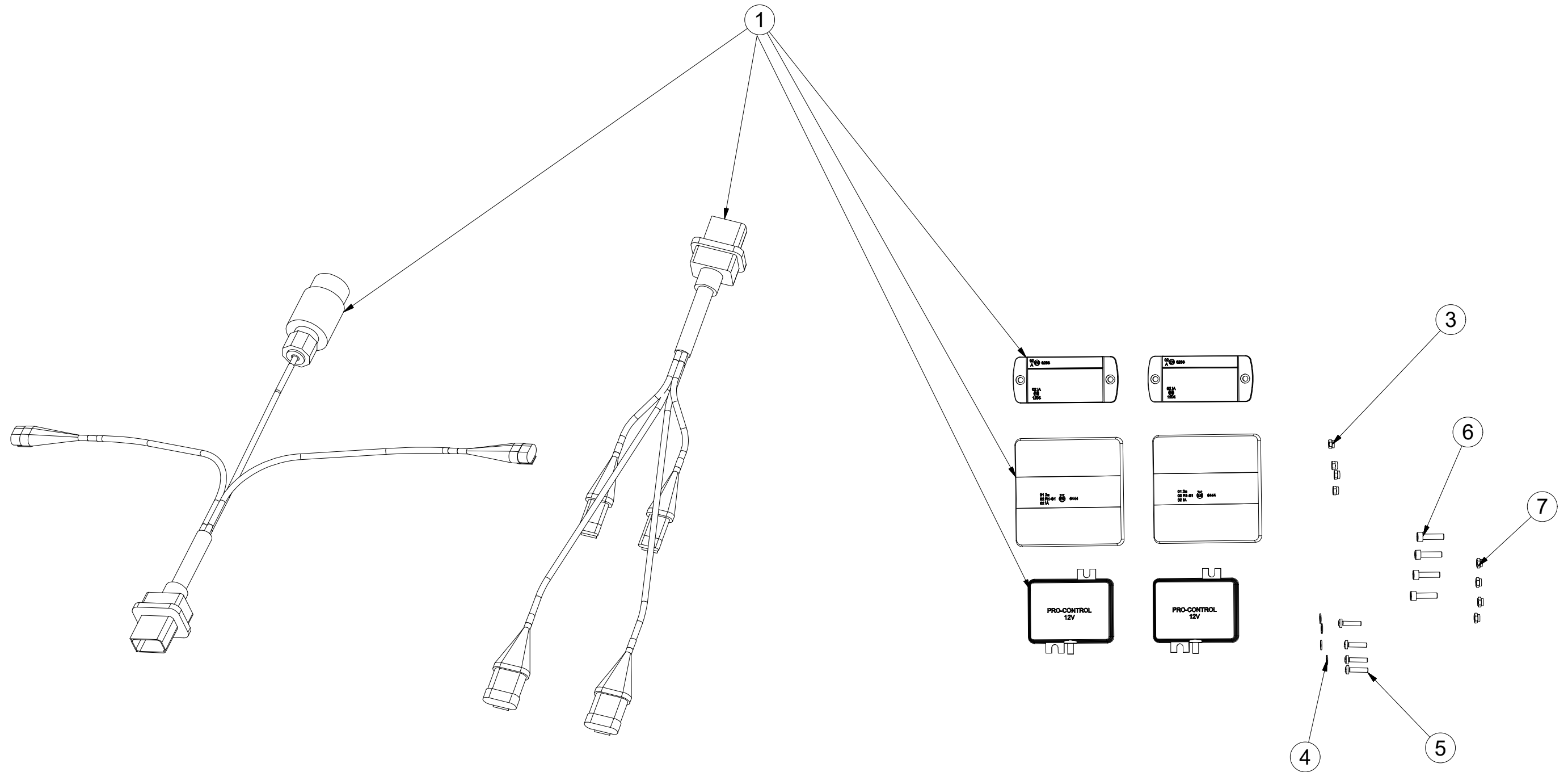

Pos.	Part Number	Pcs.
1	m15240	1
3	m05562	4
4	m05597	4
5	m15790	4
6	m10591	4
7	m06236	4
30	m05566	50

Ⓒ SVĚTELNÁ SADA

Ⓓ LEUCHTENSATZ

Ⓕ KIT LUMINEUX

**m15240**

Ⓖ LIGHTING SET

Ⓡ ОСВЕТИТЕЛЬНЫЙ КОМПЛЕКТ

Ⓟ ZESTAW OŚWIETLENIA

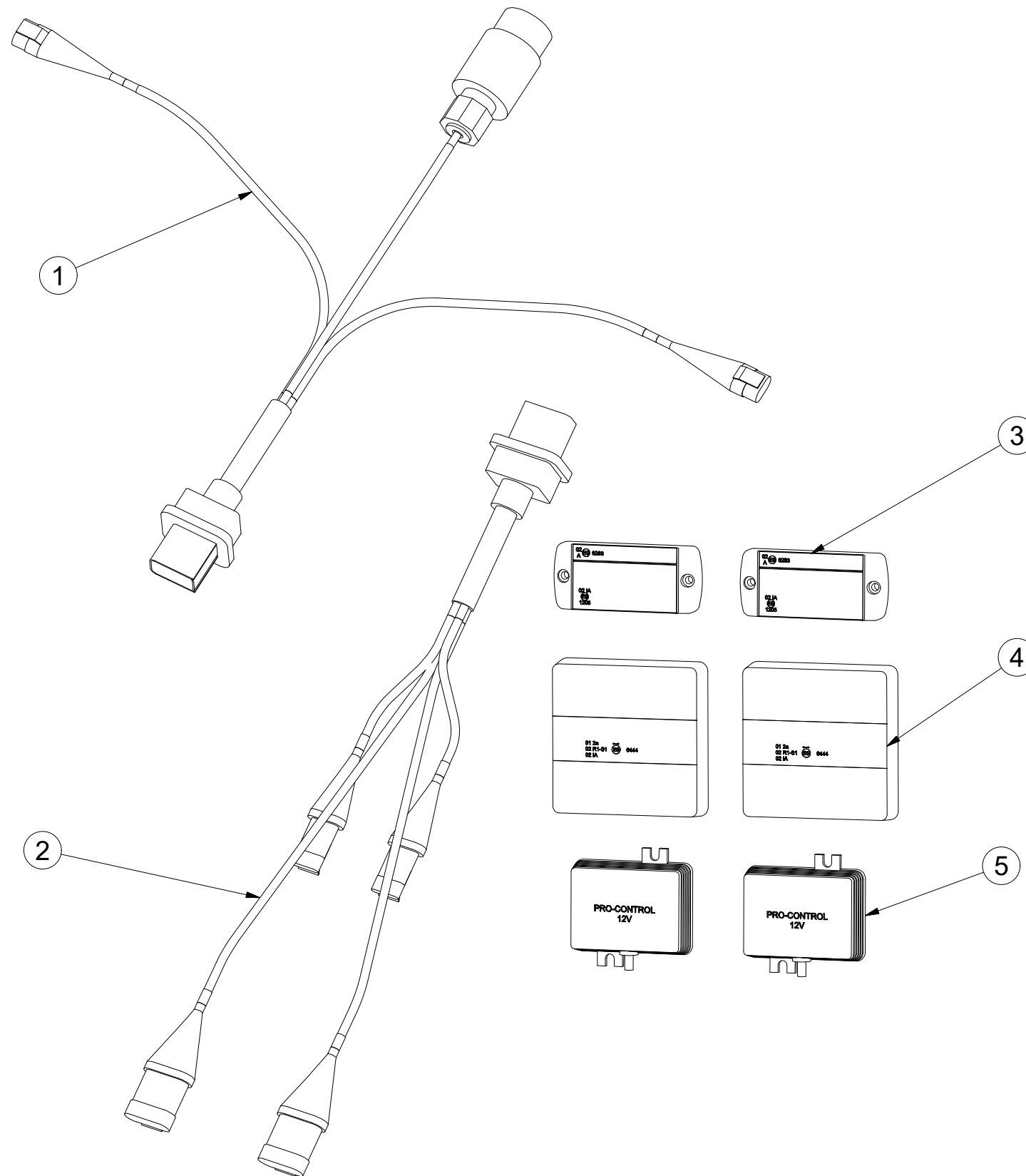

Pos.	Part Number	Pcs.
1	m14779	1
2	m14778	1
3	m14776	2
4	m14865	2
5	m14777	2

Ⓒ CZ SOUPRAVA TĚSNIVA PÍSTNIC

Ⓓ D KOLBENSTANGENDICHTUNGSMITTELSATZ

Ⓕ F SET DE GARNITURE DES TIGES DE PISTON

Ⓖ GB SEALING SET FOR PISTON RODS

Ⓔ RU КОМПЛЕКТ ПРОКЛАДОК ЦИЛИНДРОВ

Ⓗ PL ZESTAW USZCZELEK TRZPIENIA TŁOKA

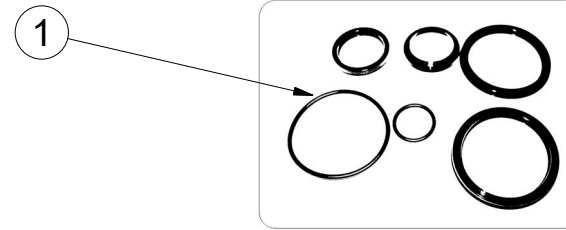
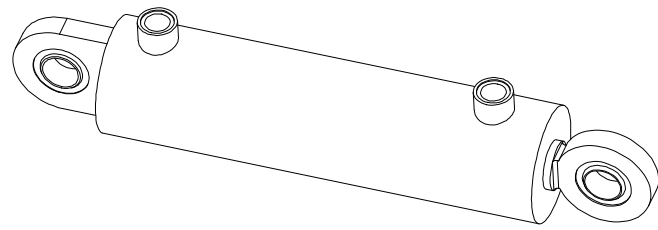

9000247 - $\varnothing 80/\varnothing 40-250$		
Pos	Part number	Pcs
1	m03528	2

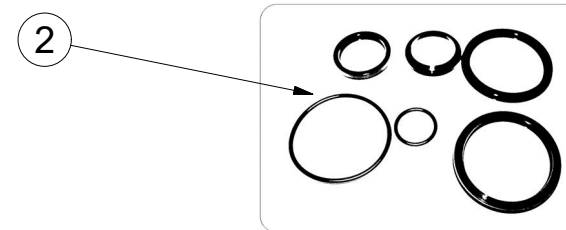
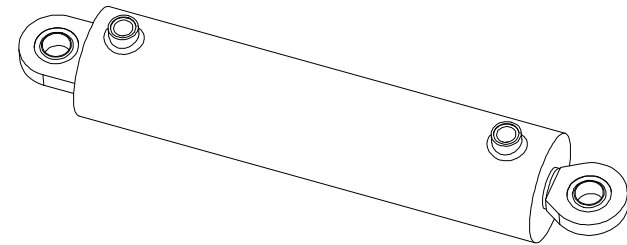

9002967 - $\varnothing 100/\varnothing 45-400$		
Pos	Part number	Pcs
2	m05504	2

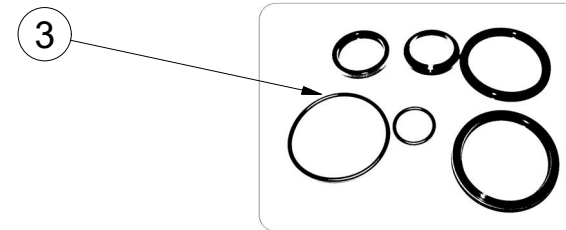
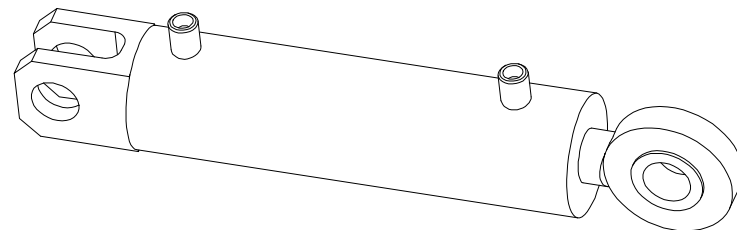

8000734-90007 - $\varnothing 40/\varnothing 22-100$		
Pos	Part number	Pcs
3	m05676	6