

The effective technology

Farmet®

ⒸZ KATALOG NÁHRADNÍCH DÍLŮ ⒸB CATALOGUE OF SPARE PARTS ⒸD ERSATZTEILLISTE
ⒸRU КАТАЛОГ ЗАПАСНЫХ ЧАСТЕЙ ⒸF CATALOGUE DES PIÈCES DE RECHANGE ⒸPL KATALOG CZĘŚCI ZAMIENNYCH

SOFTER 8 PS

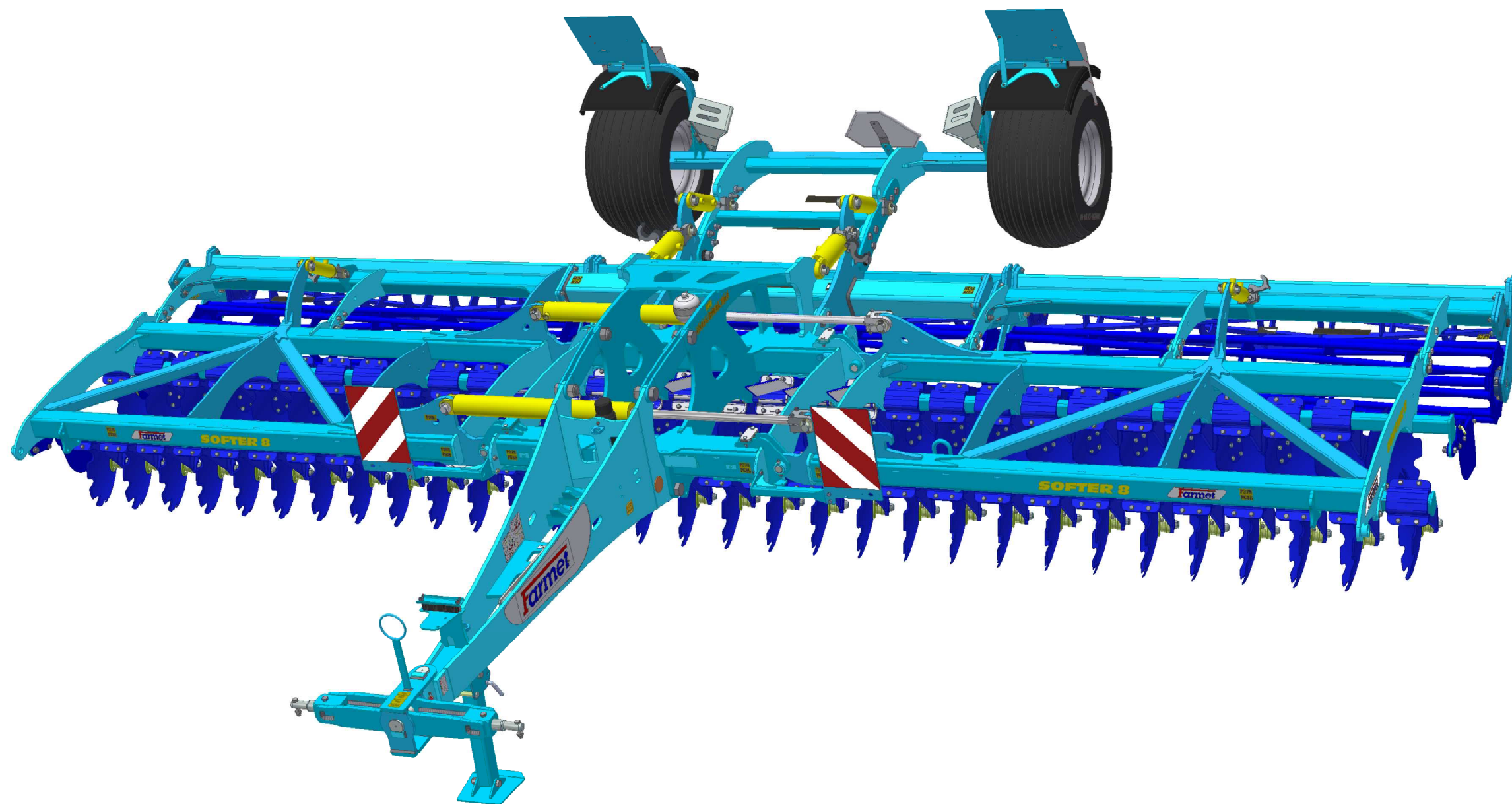

ⒸZ Platnost pro vrcholové | výrobní číslo stroje ⒸB Validity for the top | serial number of the machine
ⒸD Gültigkeit für die Haupt- | Herstellungsnummer der Maschine ⒸRU Действительно для главного | заводского номера машины
ⒸF Validité du numéro de référence | de série de la machine ⒸPL Obowiązuje dla numeru głównego | seryjnego maszyny

9316313 | 2017/0478

Farmet a. s.
Jiřinková 276
552 03 Česká Skalice, CZ

telefon: +420 491 450 111
fax: +420 491 450 136
GSM: +420 774 715 738

IČ: 46504931
DIČ: CZ46504931

web: www.farmet.cz
e-mail: farmet@farmet.cz

ⒸZ NAVIGACE STROJE

Ⓓ NAVIGATION DER MASCHINE

Ⓕ NAVIGATION DE LA MACHINE

ⒸB NAVIGATION OF THE MACHINE

ⒸU НАВИГАЦИЯ МАШИНЫ

ⒸL NAWIGACJA MASZYNY

Farmet

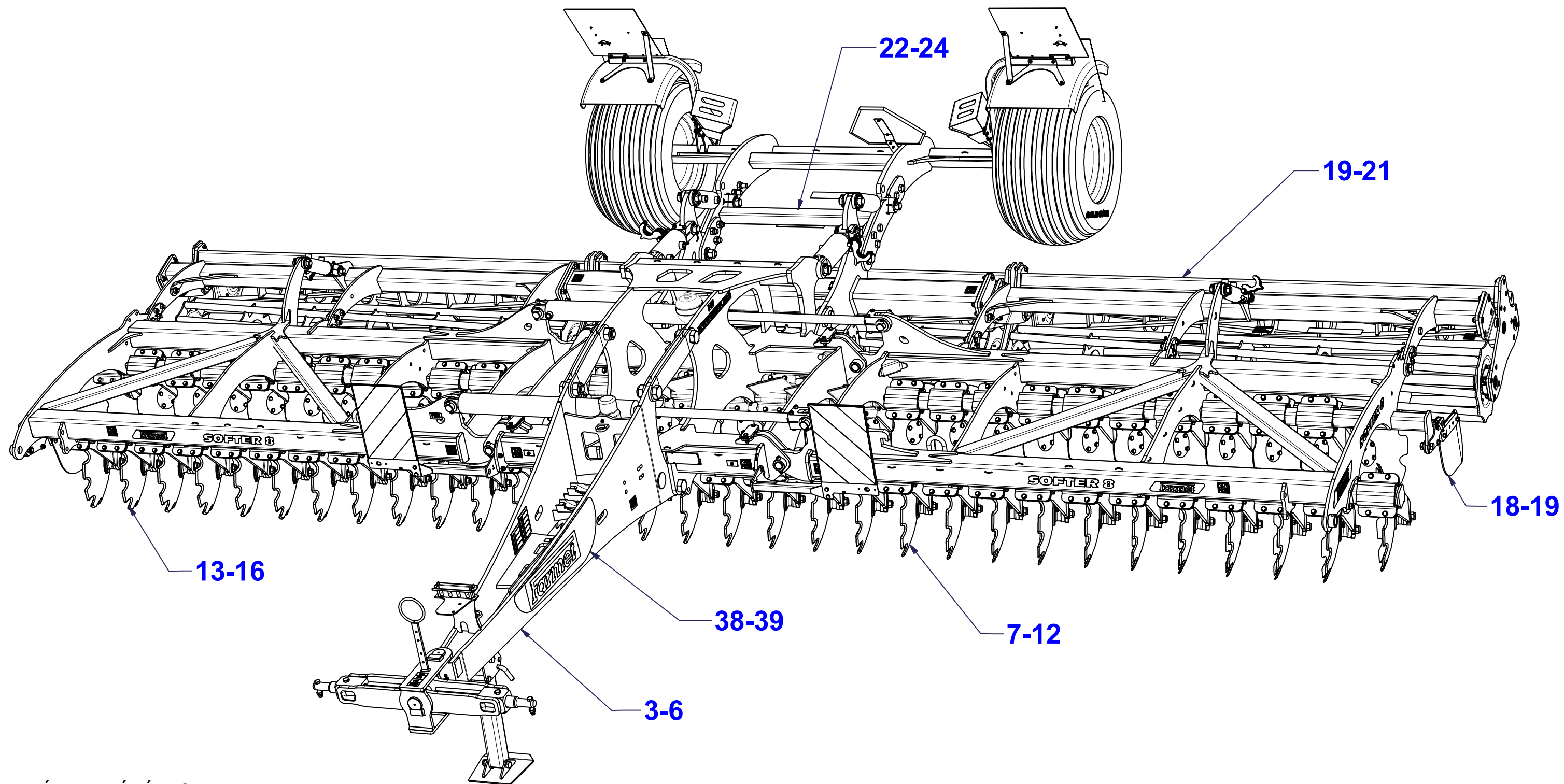

ⒸZ NÁHRADNÍ DÍL - STRANA

ⒸB SPARE PART - PAGE

Ⓓ ERSATZTEILE - SEITE

ⒸU ЗАПЧАСТЬ - СТРАНИЦА

Ⓕ PIÈCE DE RECHANGE - PAGE

ⒸL CZĘŚCI ZAMIENNE - STRONA

Ⓒ CZ OJ T3

Ⓓ DEICHSEL T3

Ⓕ TIMON T3

Ⓖ GB TOW BAR T3

Ⓡ RU ДЫШЛО T3

Ⓟ PL DYSZEL T3



3007650

Pos.	Part Number	Pcs.
1	2000757	1
2	3002410	1
3	4008216	1
4	4007000	1
5	4006699	1
7	4014721	4
10	4003745	1
11	4003744	1
12	4004007	1
13	4007817	1
14	4007818	1
20	m04404	1
21	m05465	2
22	m12179	6
30	m02533	2
32	m03683	1
33	m05648	2
34	m11337	6
40	m01219	1
41	m03866	2
42	m03768	2
50	m08386	1
51	m04139	2
54	m10454	1
55	m01725	1

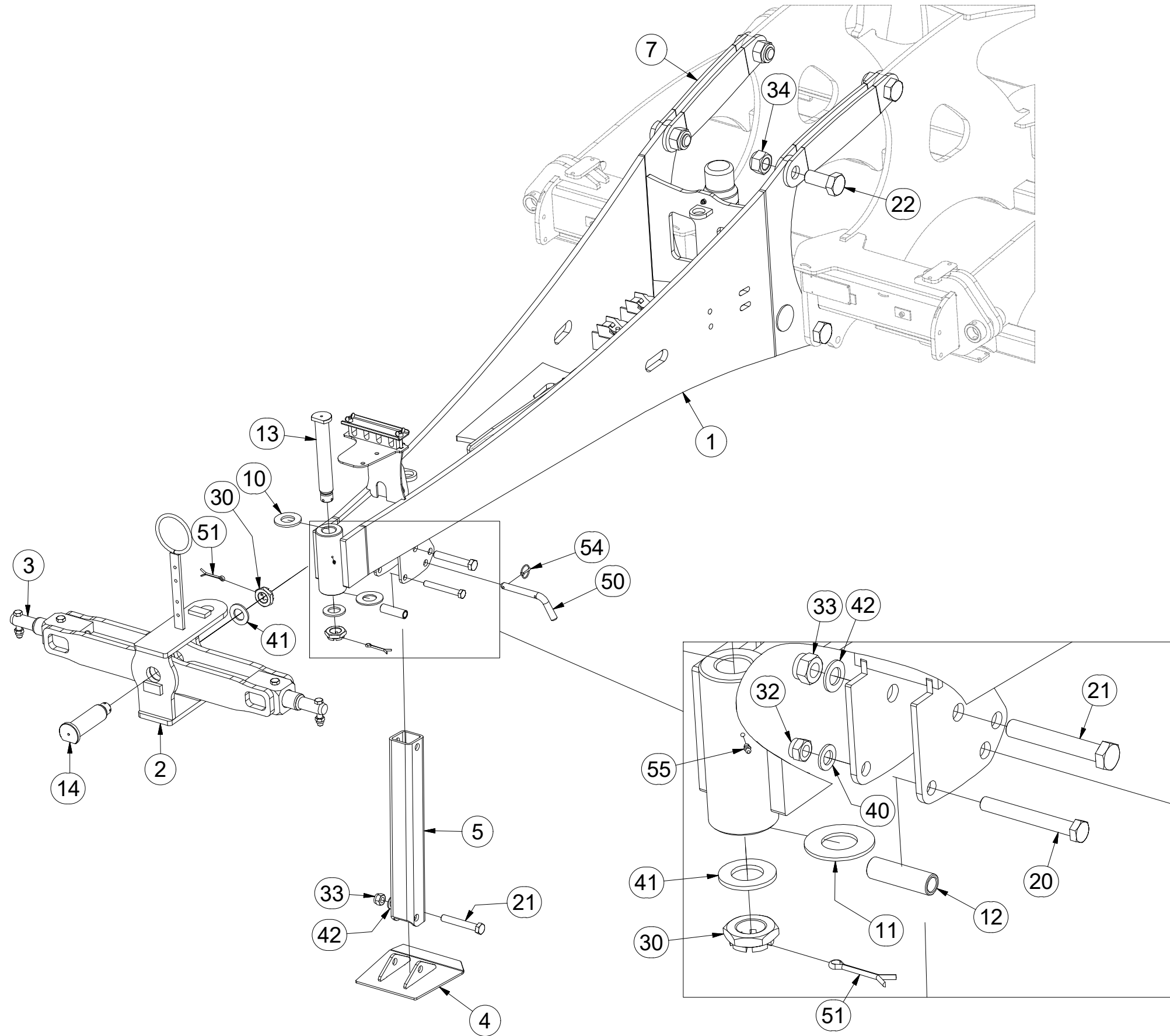

ⒸZ OJ T3

Ⓓ DEICHSEL T3

Ⓕ TIMON T3

ⒼB TOW BAR T3

ⒺU ДЫШЛО T3

ⒼL DYSZEL T3



3007650

Pos.	Part Number	Pcs.
1	2000757	1
6	4009359	1
8	4005201	1
9	4004109	1
23	m09247	2
24	m01096	2
31	m01316	2
35	m04503	2
43	m01203	2
52	m02579	2
53	m02505	1
60	m15900	1

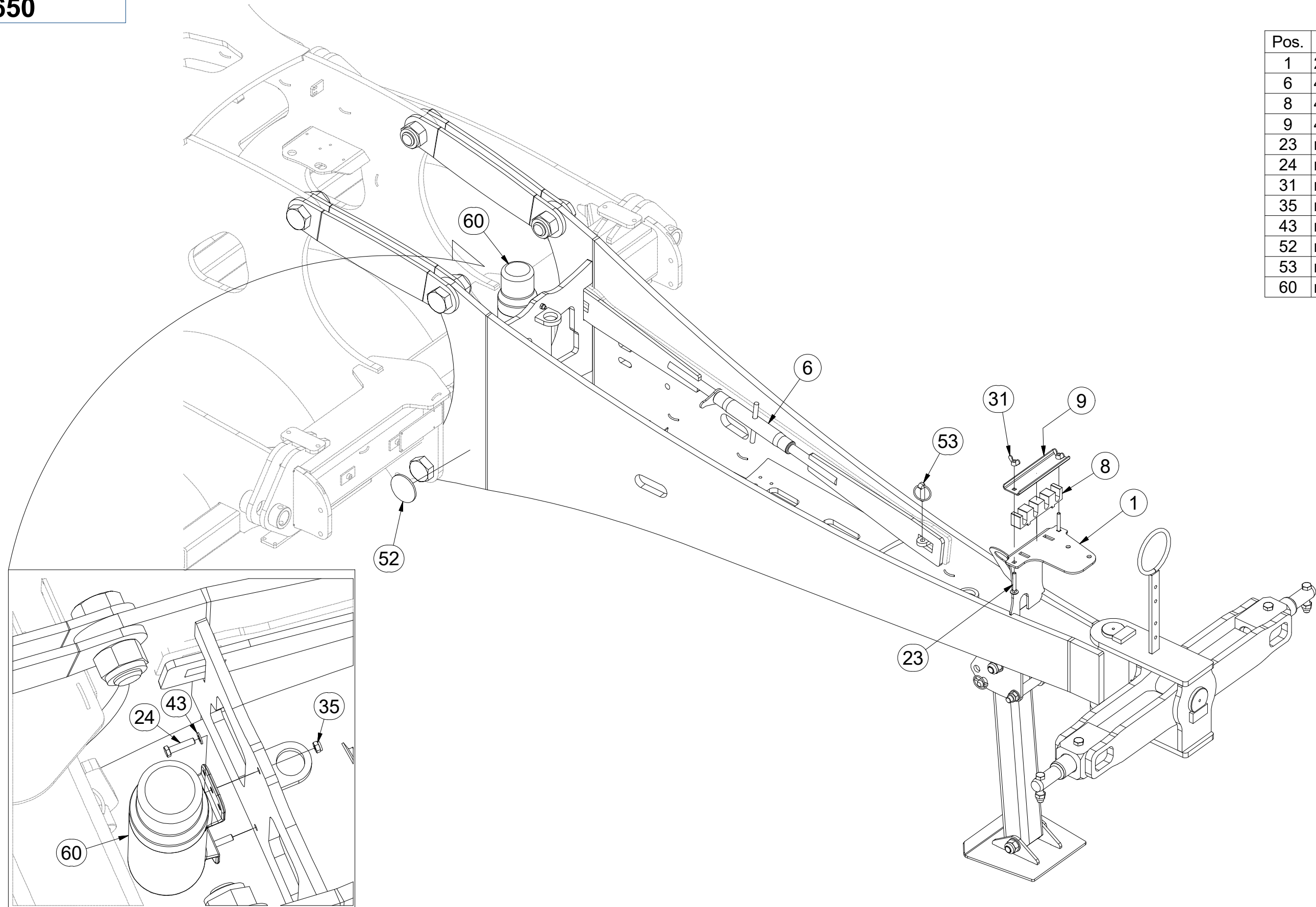

Ⓒ SPOJOVACÍ TÁHLO
Ⓓ VERBINDUNGSSTANGE
Ⓕ TIGE DE RACCORDEMENT

Ⓖ CONNECTING ROD
Ⓡ СОЕДИНИТЕЛЬНАЯ ТЯГА
Ⓟ KORBOWÓD



4009359

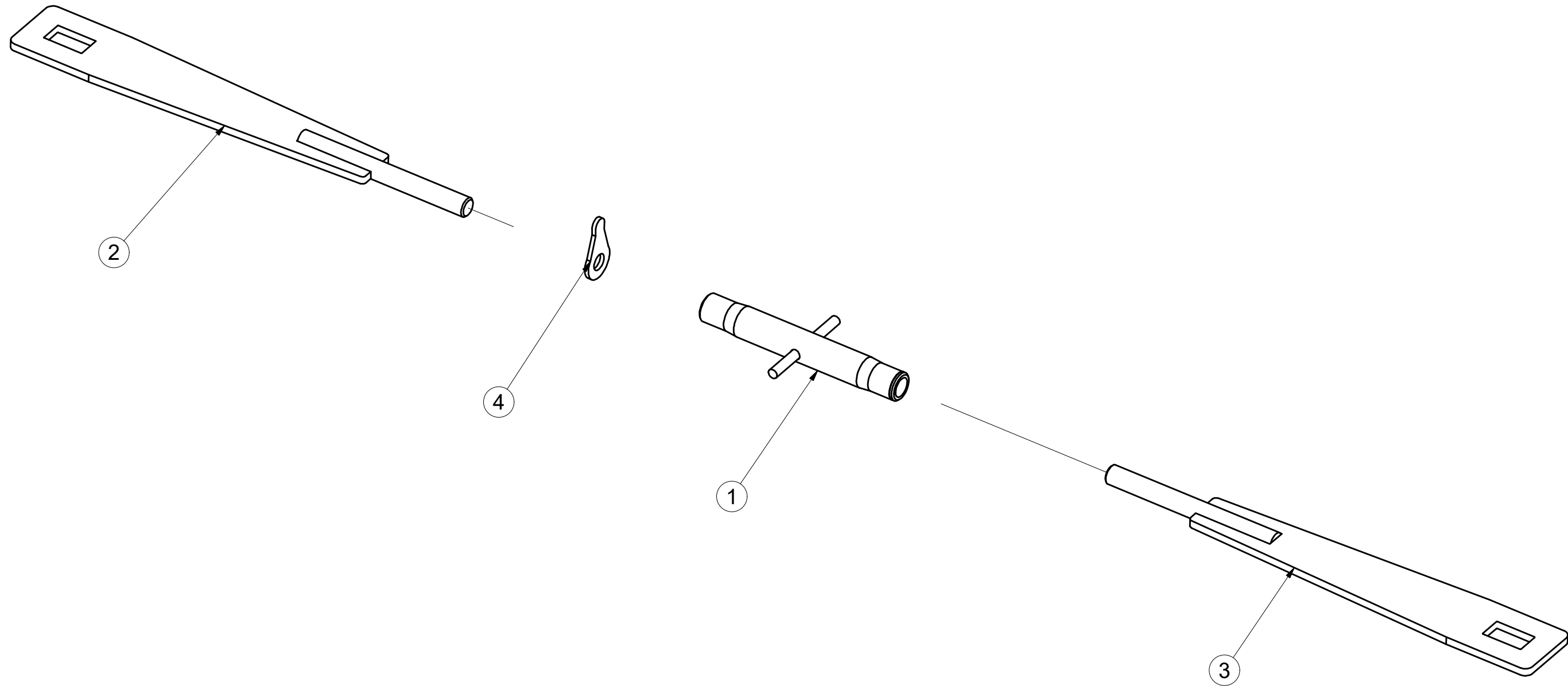

Pos.	Part Number	Pcs.
1	m08880	1
2	4009356	1
3	4009360	1
4	m08881	1

Ⓒ ZÁVĚSNÁ TYČ T3

Ⓓ KÖNIGSSTANGE T3

Ⓕ TIGE DE SUSPENSION T3

4008216

Ⓖ DRAWBAR T3

Ⓡ ПОДВЕШАЯ ШТАНГА Т3

Ⓟ PRĘT ZAWIESZANY T3

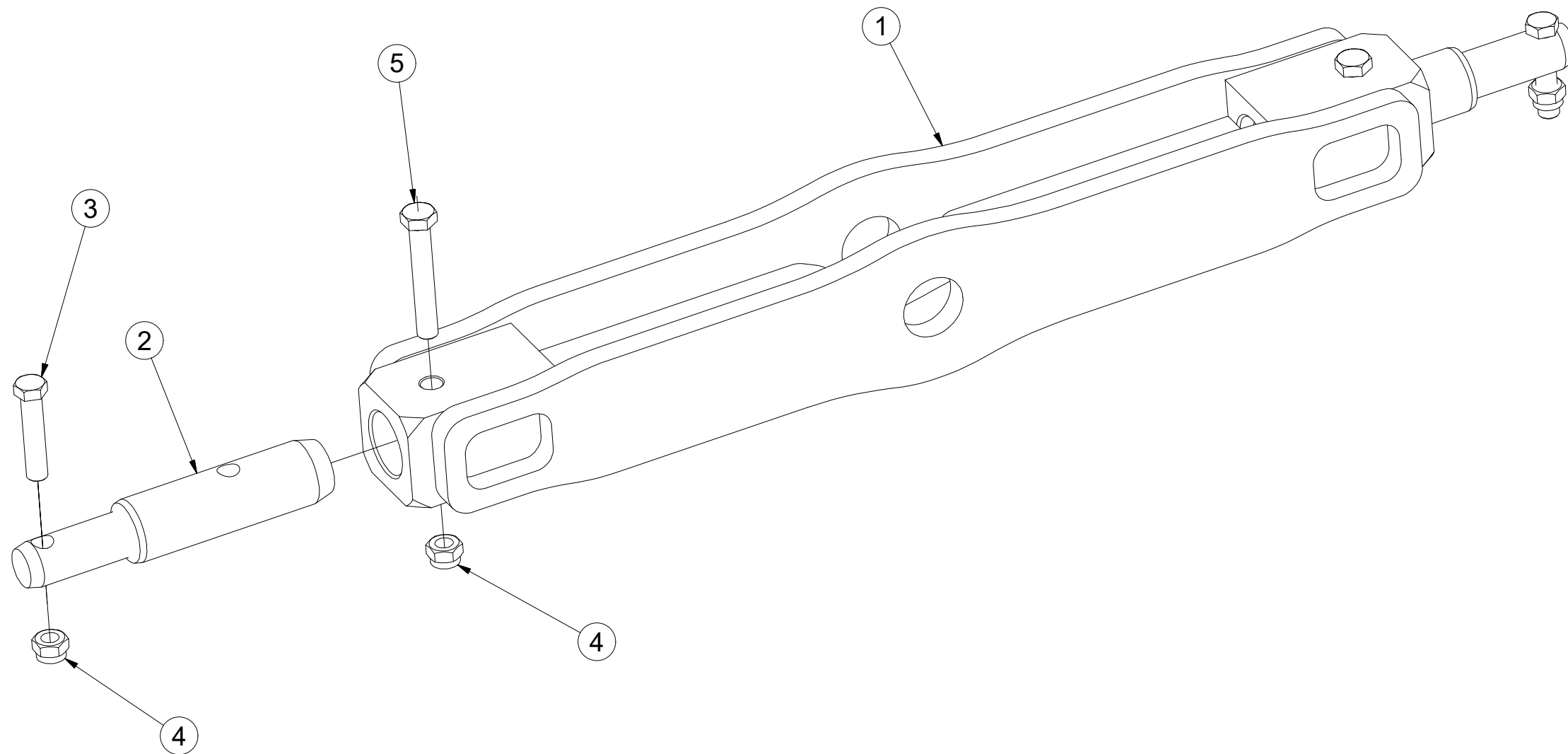

Pos.	Part Number	Pcs.
1	3004315	1
2	4008217	2
3	m01133	2
4	m03683	4
5	m05304	2

Ⓒ ZÁKLAD STROJE

Ⓓ UNTERBAU DER MASCHINE

Ⓕ BÂTI DE LA MACHINE

Ⓖ FOOTING OF THE MACHINE

Ⓡ ОСНОВАНИЕ МАШИНЫ

Ⓢ ПОДСТАВА МАСЗЫНЫ



3008713

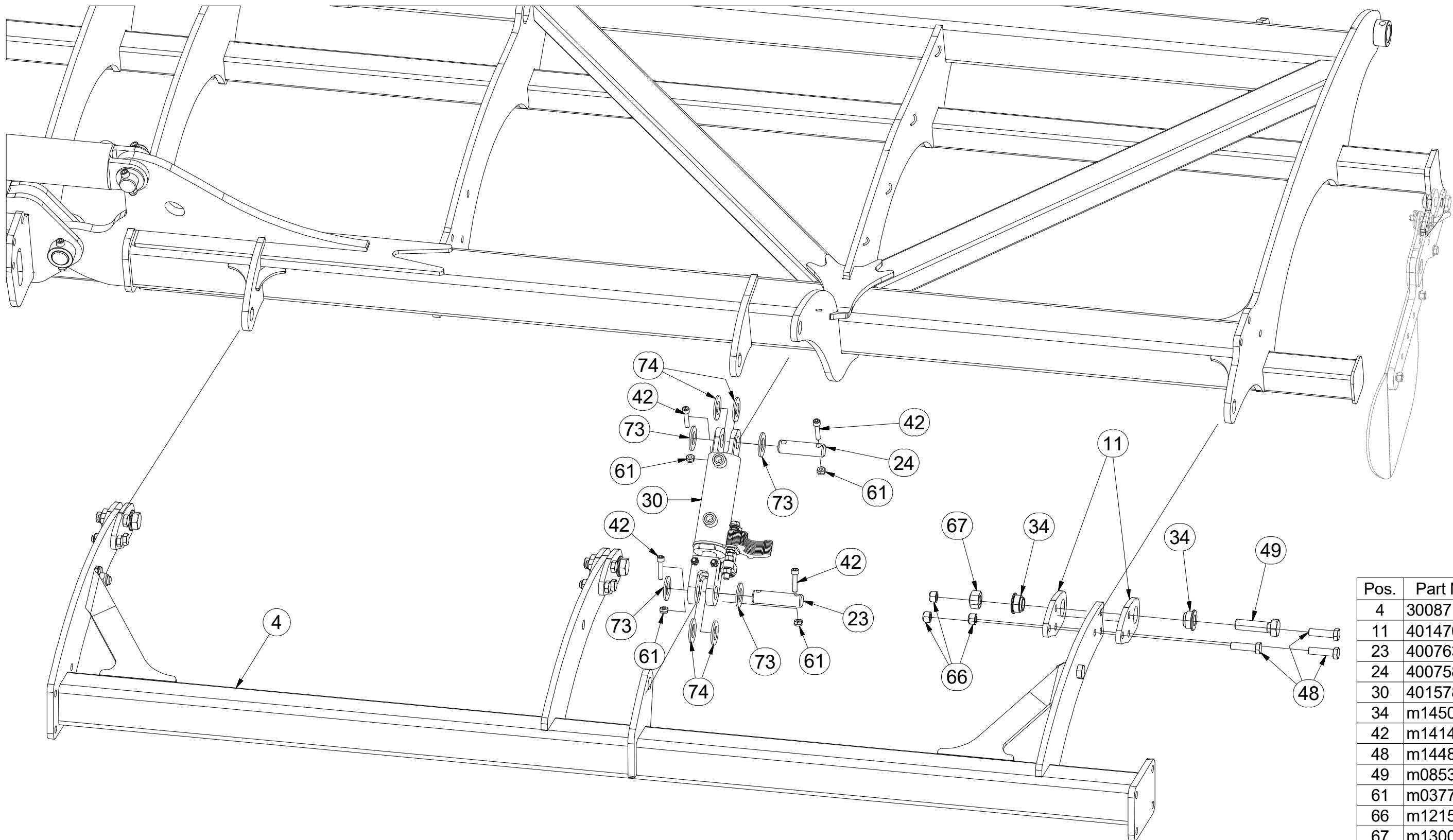

Pos.	Part Number	Pcs.
4	3008715	1
11	4014704	12
23	4007639	2
24	4007584	2
30	4015781	2
34	m14506	12
42	m14143	8
48	m14482	18
49	m08532	6
61	m03775	8
66	m12150	18
67	m13009	12
73	m14029	8
74	m02866	9

ⒸZ ZÁKLAD STROJE

Ⓓ UNTERBAU DER MASCHINE

Ⓕ BÂTI DE LA MACHINE

ⒼB FOOTING OF THE MACHINE

ⒶO ОСНОВАНИЕ МАШИНЫ

ⒶL PODSTAWA MASZINY



3008713

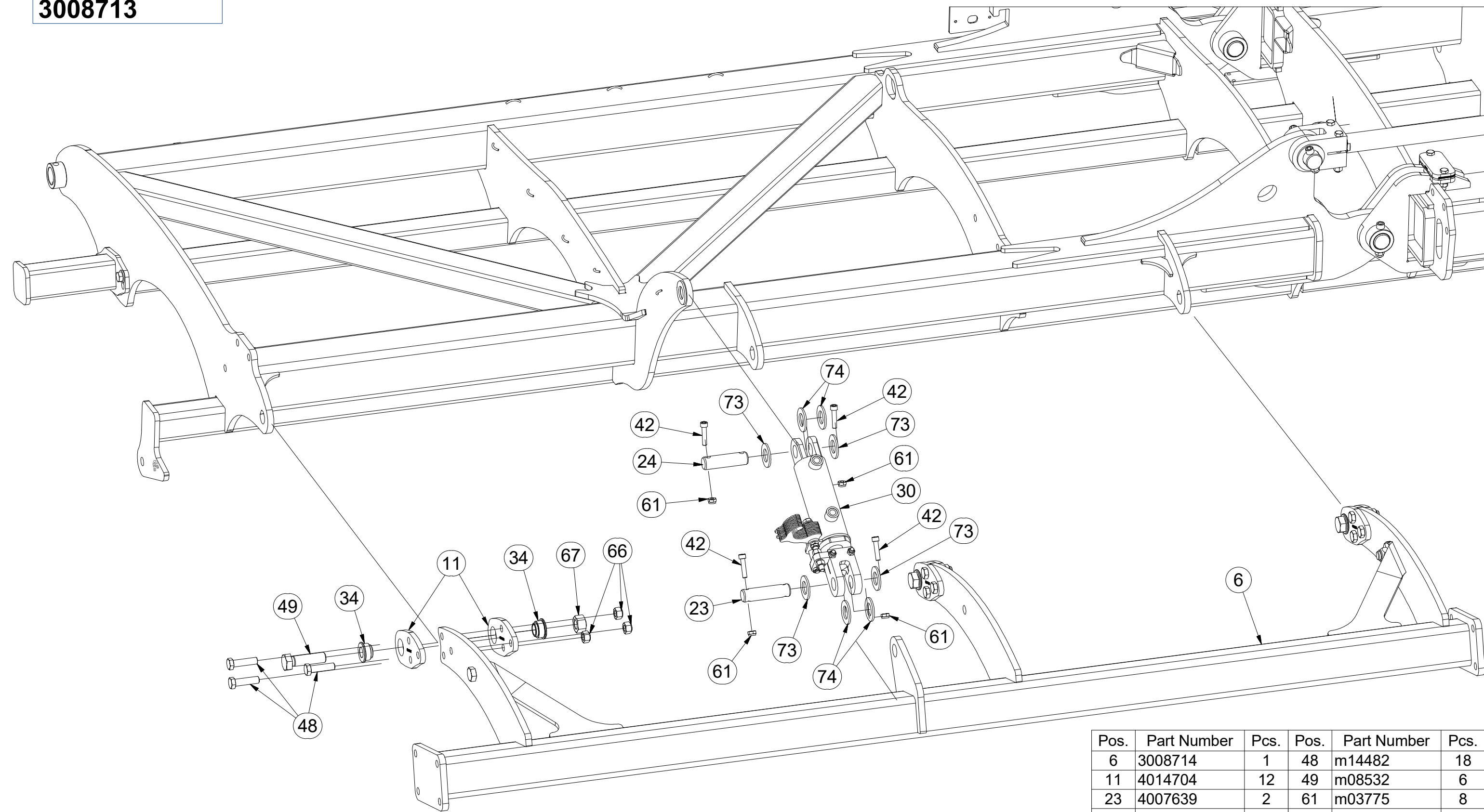

Pos.	Part Number	Pcs.	Pos.	Part Number	Pcs.
6	3008714	1	48	m14482	18
11	4014704	12	49	m08532	6
23	4007639	2	61	m03775	8
24	4007584	2	66	m12150	18
30	4015781	2	67	m13009	12
34	m14506	12	73	m14029	8
42	m14143	8	74	m02866	9

Ⓒ ZÁKLAD STROJE

Ⓓ UNTERBAU DER MASCHINE

Ⓕ BÂTI DE LA MACHINE

Ⓖ FOOTING OF THE MACHINE

Ⓡ ОСНОВАНИЕ МАШИНЫ

Ⓢ PODSTAWA MASZyny



3008713

Pos.	Part Number	Pcs.
2	1000586	1
7	3007071	1
21	4007816	8
22	4012990	8
36	m15002	4
44	m13033	4
45	m14008	24
52	m04355	2
63	m04301	29
65	m15730	2
72	m01219	2
75	4013139	24

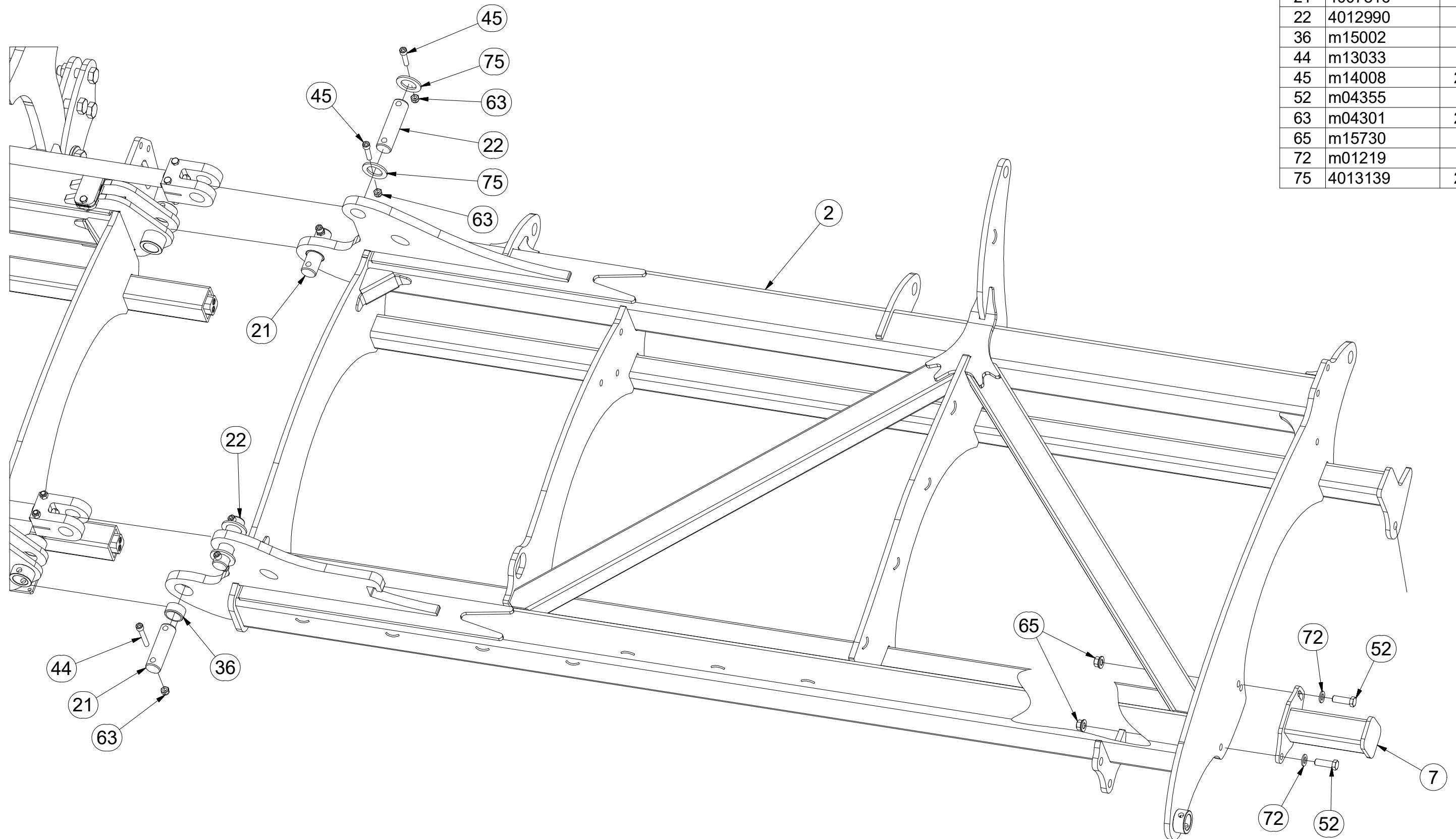

Ⓒ ZÁKLAD STROJE

Ⓓ UNTERBAU DER MASCHINE

Ⓕ BÂTI DE LA MACHINE

Ⓖ FOOTING OF THE MACHINE

Ⓡ ОСНОВАНИЕ МАШИНЫ

Ⓢ ПОДСТАВА МАСЗЫНЫ



3008713

Pos.	Part Number	Pcs.	Pos.	Part Number	Pcs.
3	1000588	1	45	m14008	24
18	4017090	12	51	m14009	8
19	4017091	8	63	m04301	29
20	4017089	4	75	4013139	24
21	4007816	8	76	m01208	8
36	m15002	4			
44	m13033	4			

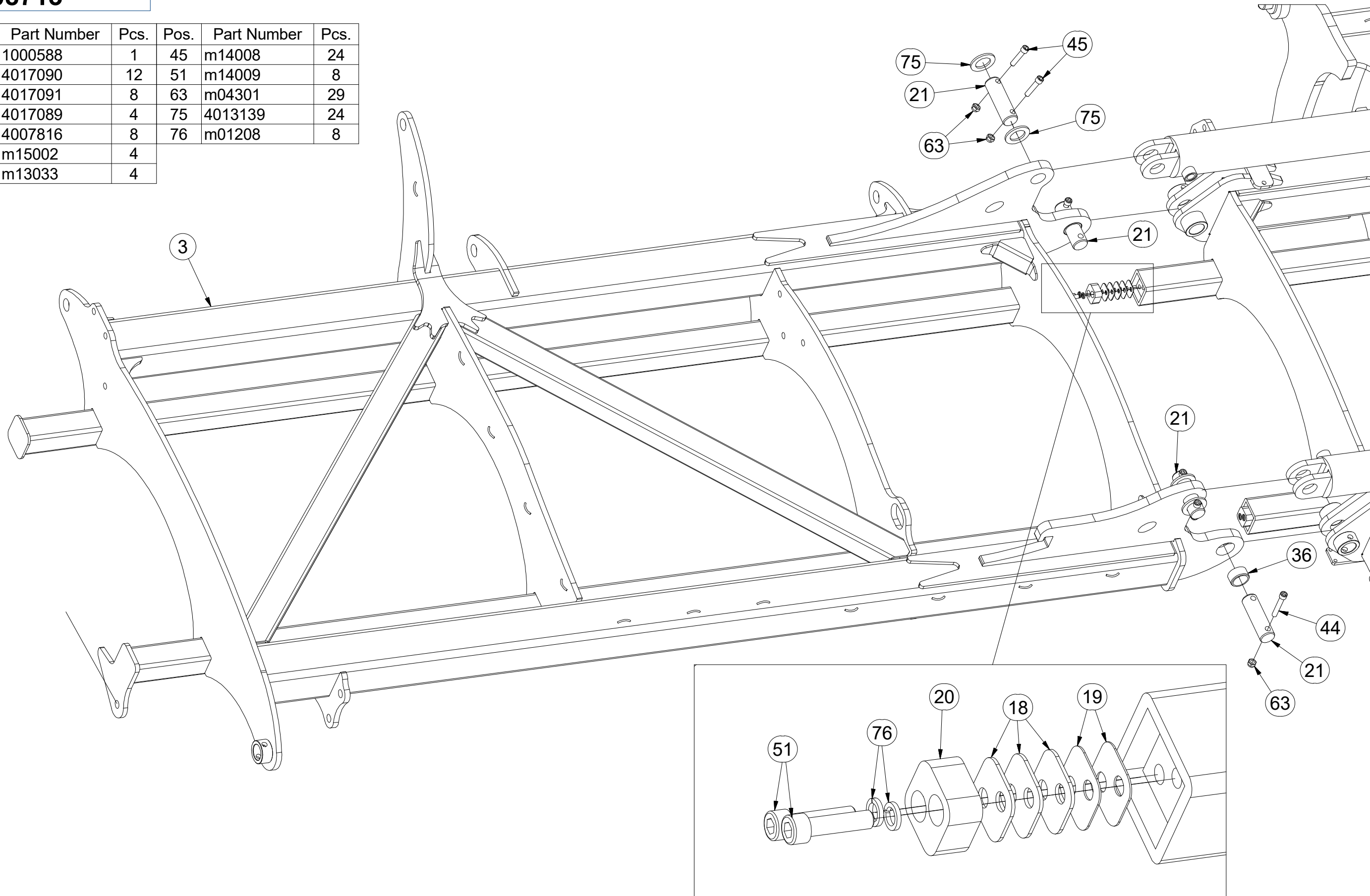

Ⓒ ZÁKLAD STROJE

Ⓓ UNTERBAU DER MASCHINE

Ⓕ BÂTI DE LA MACHINE

Ⓖ FOOTING OF THE MACHINE

Ⓡ ОСНОВАНИЕ МАШИНЫ

Ⓢ PODSTAWA MASZYNY



3008713

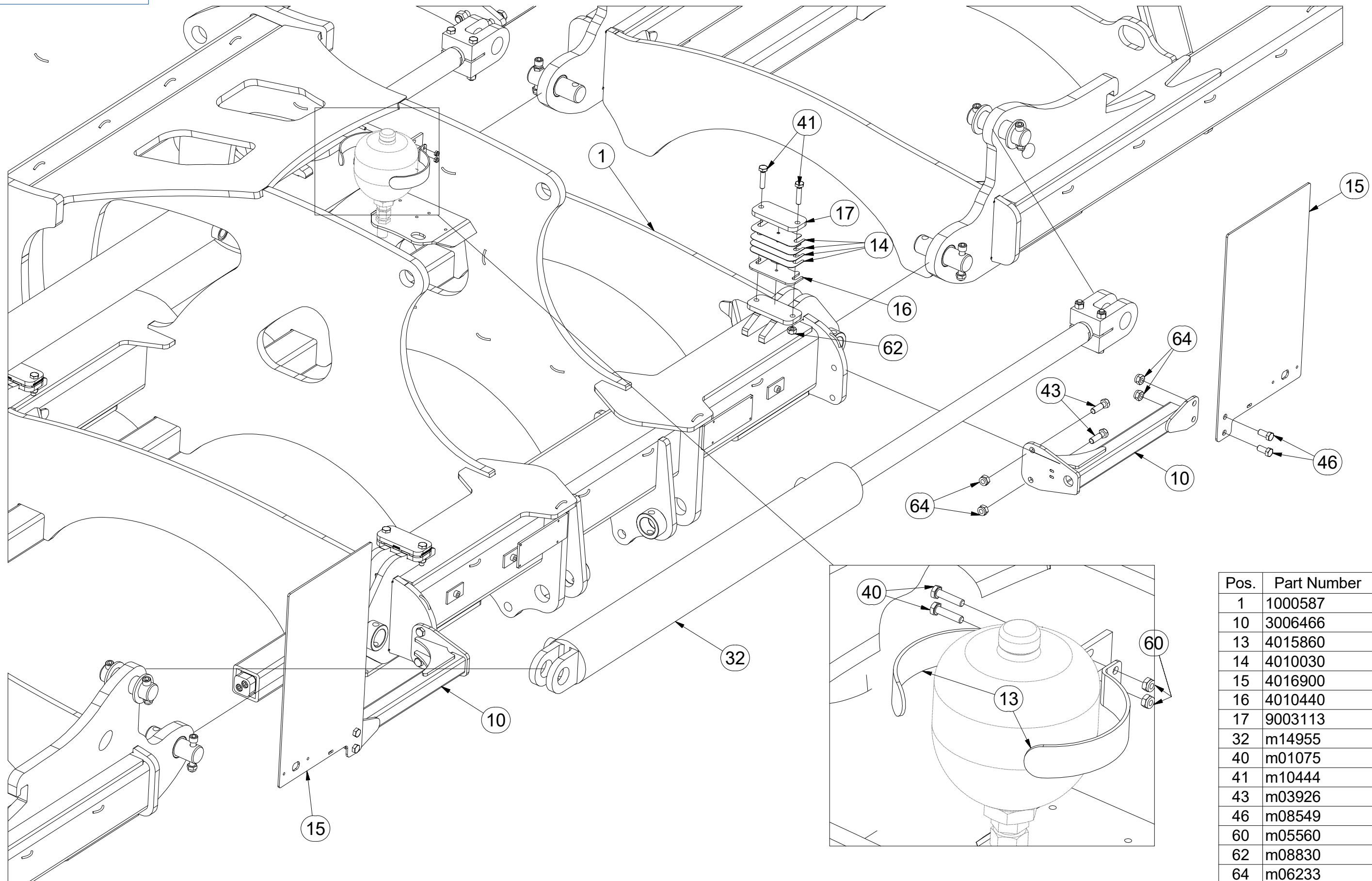

Pos.	Part Number	Pcs.
1	1000587	1
10	3006466	2
13	4015860	2
14	4010030	16
15	4016900	2
16	4010440	4
17	9003113	4
32	m14955	2
40	m01075	2
41	m10444	8
43	m03926	4
46	m08549	4
60	m05560	2
62	m08830	8
64	m06233	8

☉ ZÁKLAD STROJE

Ⓧ UNTERBAU DER MASCHINE

Ⓧ BÂTI DE LA MACHINE

Ⓧ FOOTING OF THE MACHINE

Ⓧ ОСНОВАНИЕ МАШИНЫ

Ⓧ PODSTAWA MASZYNY



3008713

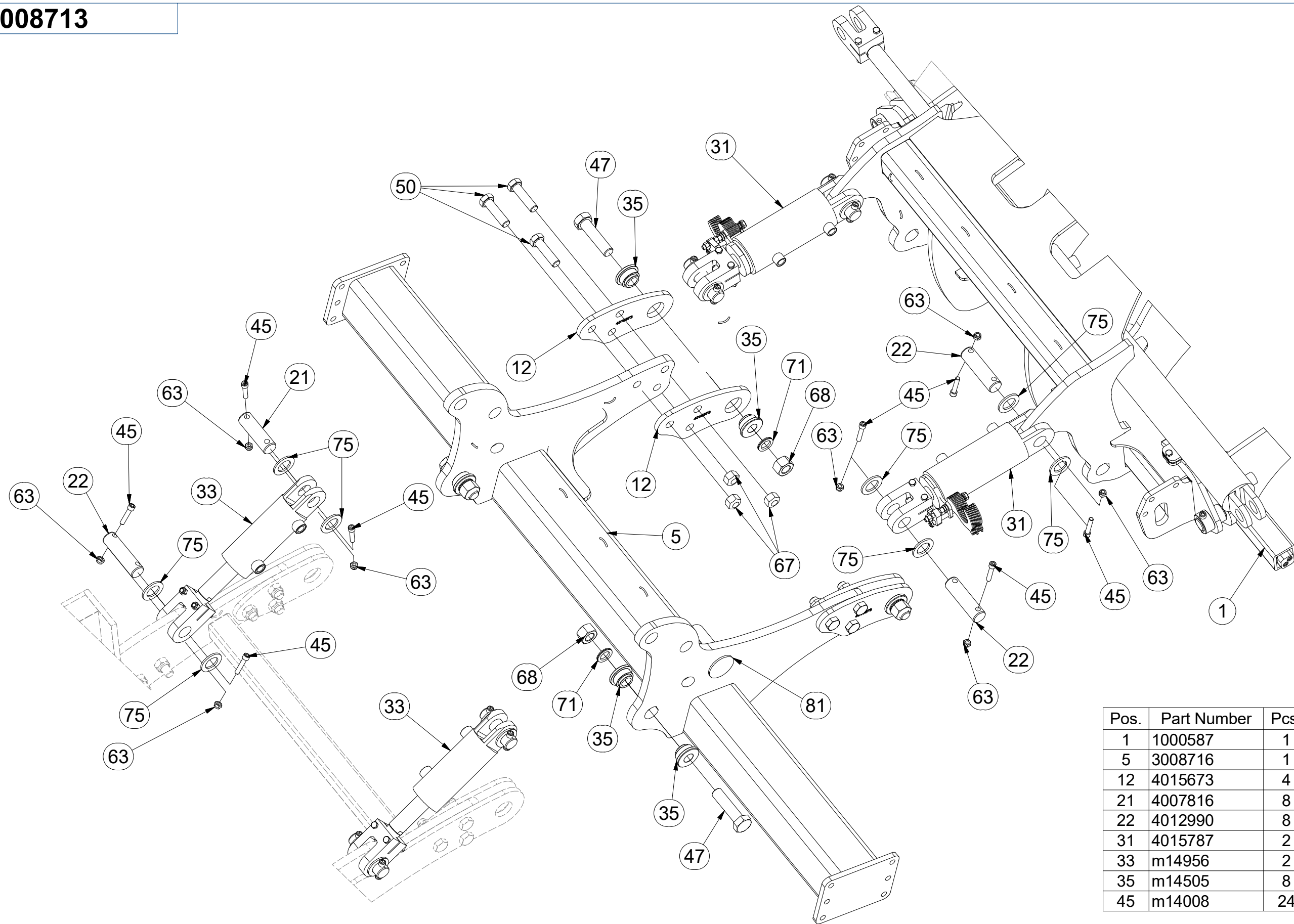

Pos.	Part Number	Pcs.	Pos.	Part Number	Pcs.
1	1000587	1	47	m15773	4
5	3008716	1	50	m14495	6
12	4015673	4	63	m04301	29
21	4007816	8	67	m13009	12
22	4012990	8	68	m14498	4
31	4015787	2	71	m13906	4
33	m14956	2	75	4013139	24
35	m14505	8	81	m02579	2
45	m14008	24			

CZ SADA DISKŮ
 D SCHEIBENSATZ
 F KIT DE DISQUES

GB DISC SET
 RU КОМПЛЕКТ ДИСКОВ
 PL ZESTAW TALERZY



3008121

Pos.	Part Number	Pcs.
1	3008380	31
2	3008381	29
3	3008378	1
4	9004269	55
5	4016392	5

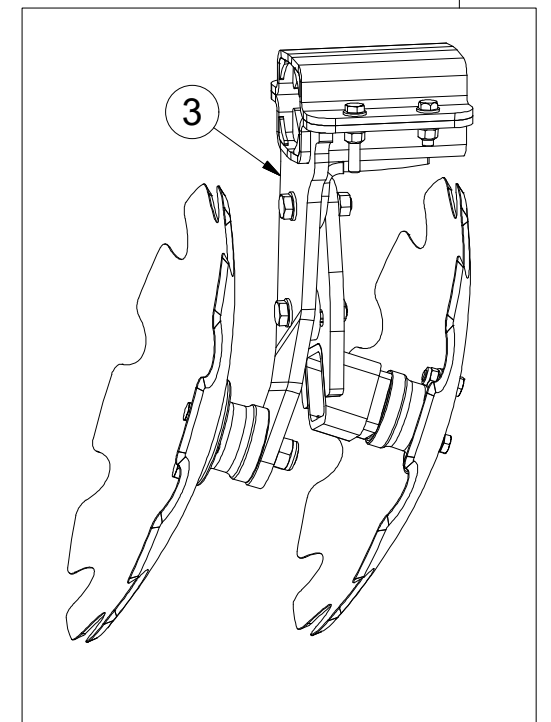
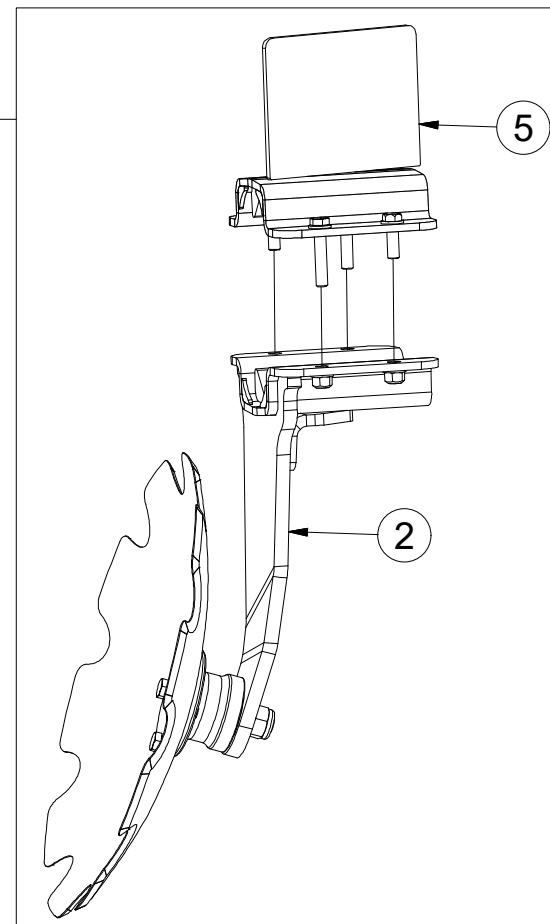
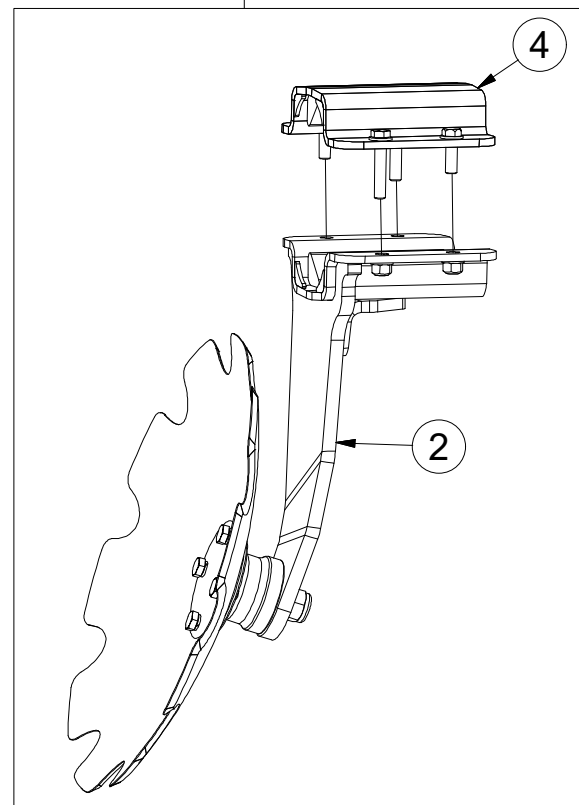
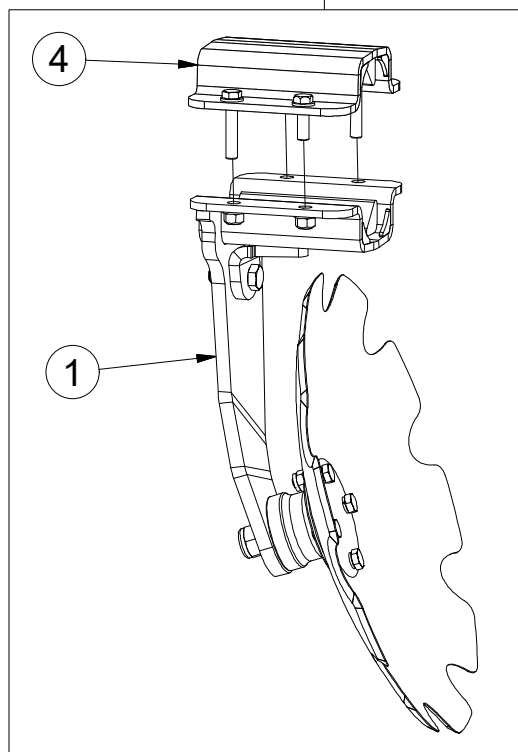
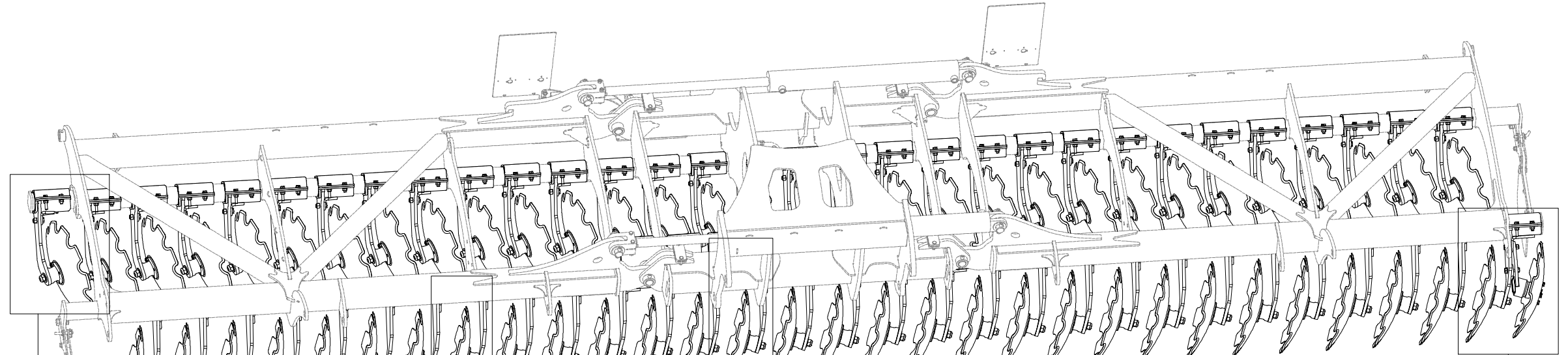

Ⓒ ZADNÍ DVOUDISK

Ⓓ DUPLEXSCHEIBE, HINTERE

Ⓕ ARRIÈRE DISQUE DOUBLE

Ⓒ REAR TWIN DISC

Ⓓ ДВОЙНОЙ ДИСК ЗАДНИЙ

Ⓕ TALERZ PODWÓJNY TYLNY



3008378

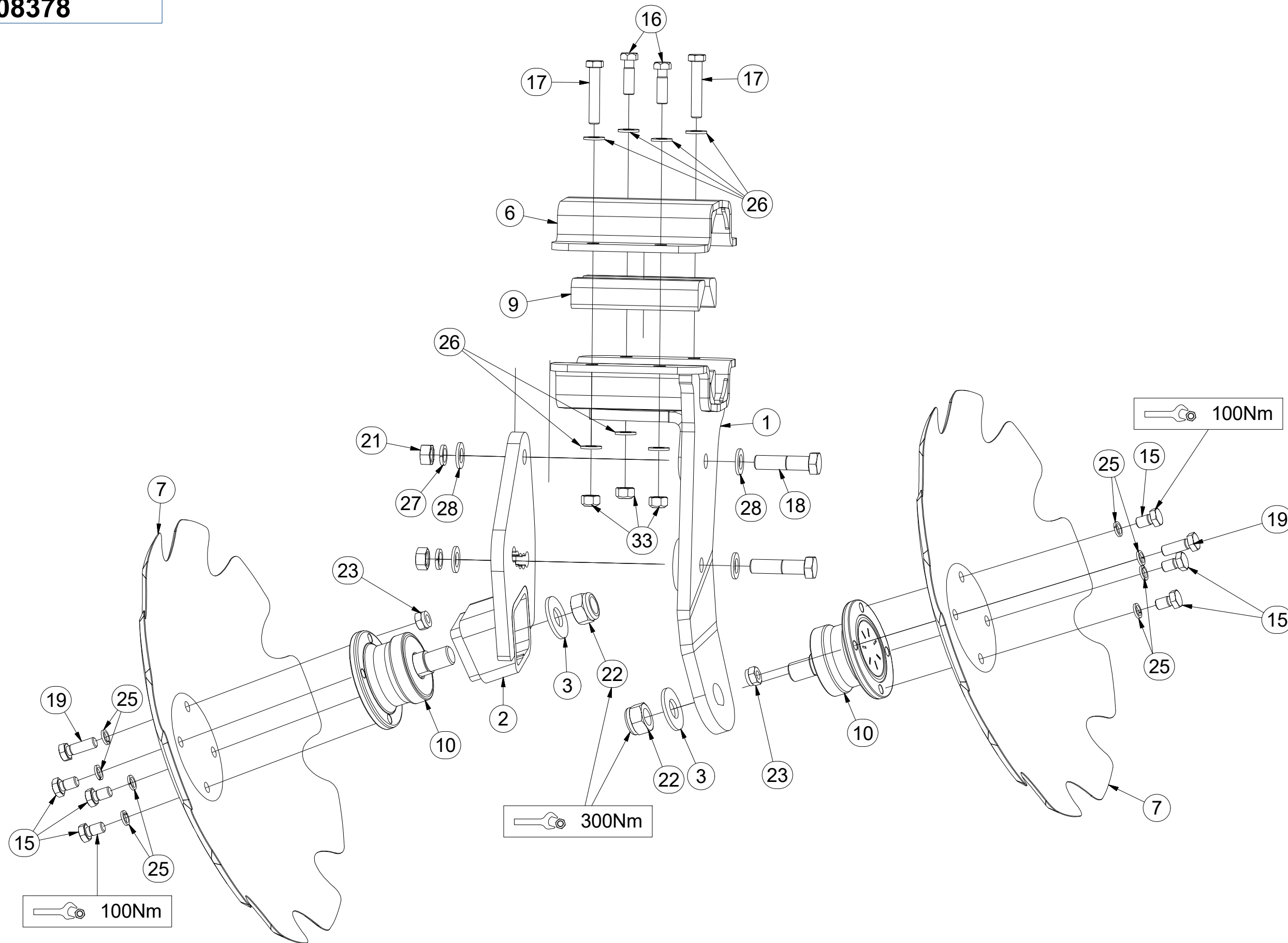

Pos.	Part Number	Pcs.
1	3008388	1
2	3004210	1
3	4007853	2
6	9004269	1
7	3007653	2
9	4016362	4
10	m11308	2
15	m11309	6
16	m09977	2
17	m14423	2
18	m06587	2
19	m11559	2
21	m01306	2
22	m11313	2
23	m11560	2
25	m03988	8
26	m01214	8
27	m02157	2
28	m01219	4
33	m12134	4

CZ PŘEDNÍ DISK
 D SCHEIBE, VORDERE
 F DISQUE AVANT

GB FRONT DISC
 RU ДИСК ПЕРЕДНИЙ
 PL TALERZ PRZEDNI



3008380

Pos.	Part Number	Pcs.
1	3008386	1
2	3007653	1
4	4007853	1
5	4016362	4
10	m11308	1
15	m11309	3
16	m09977	2
17	m14423	2
18	m11559	1
20	m11313	1
21	m12134	4
22	m11560	1
25	m03988	4
26	m01214	8

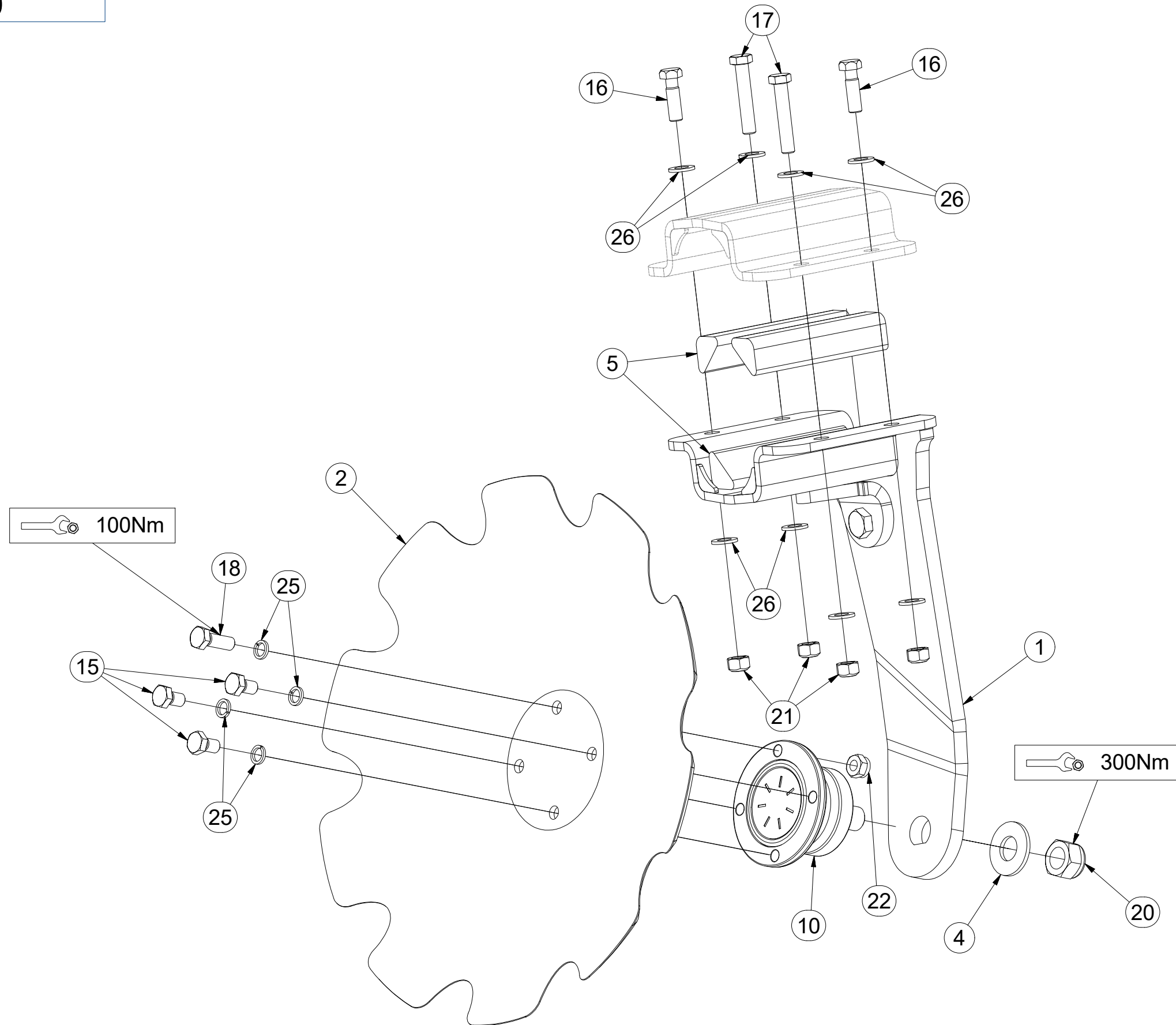

CZ ZADNÍ DISK
 D SCHEIBE, HINTERE
 F DISQUE ARRIÈRE

GB REAR DISC
 RU ДИСК ЗАДНИЙ
 PL TALERZ TYLNY



3008381

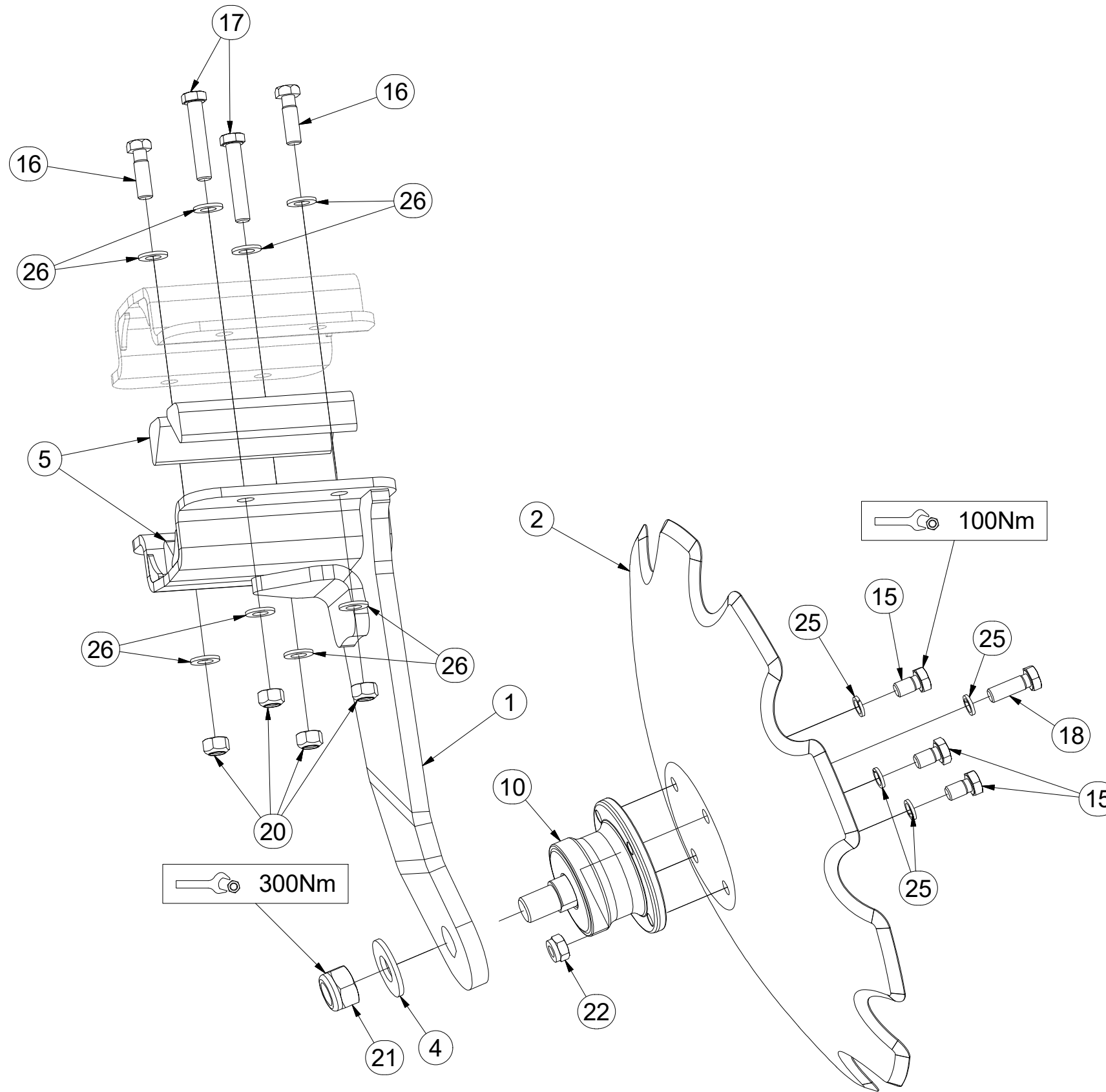

Pos.	Part Number	Pcs.
1	3008387	1
2	3007653	1
4	4007853	1
5	4016362	4
10	m11308	1
15	m11309	3
16	m09977	2
17	m14423	2
18	m11559	1
20	m12134	4
21	m11313	1
22	m11560	1
25	m03988	4
26	m01214	8

CZ PŘEDNÍ DEFLEKTOR
 D DEFLEKTOR, VORDERE
 F DÉFLECTEUR AVANT

GB FRONT DEFLECTOR
 RU ПЕРЕДНИЙ ДЕФЛЕКТОР
 PL DEFLOKTOR PRZEDNI



3004586

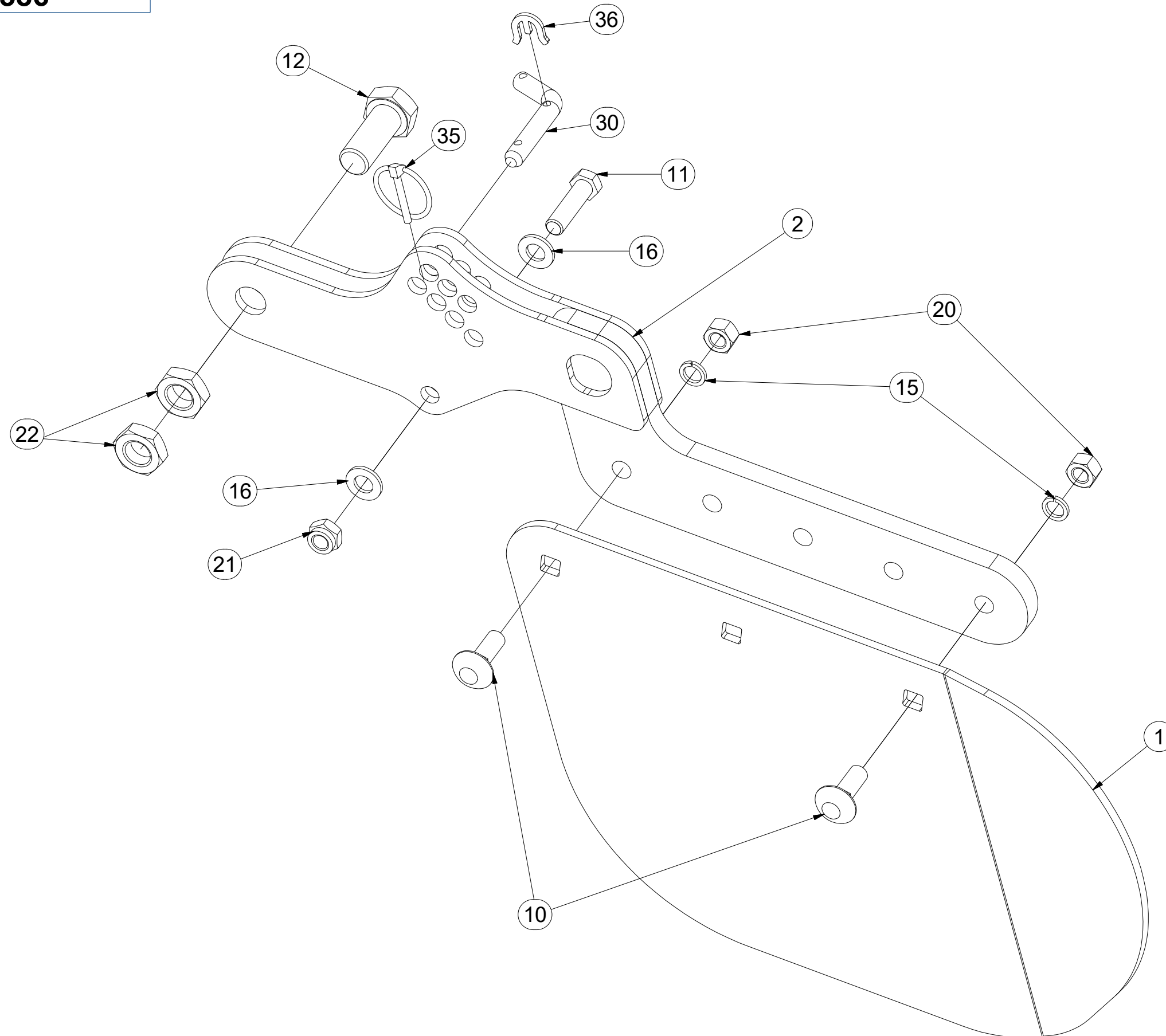

Pos	Part Number	Pcs.
1	4008155	1
2	4008743	1
10	m10618	2
11	m06077	1
12	m08378	1
15	m03988	2
16	m01214	2
20	m10439	2
21	m04301	1
22	m04284	2
30	m09141	1
35	m10454	1
36	4016279	1

CZ ZADNÍ DEFLEKTOR
 D DEFLEKTOR, HINTERE
 F DÉFLECTEUR ARRIÈRE

GB REAR DEFLECTOR
 RU ЗАДНИЙ ДЕФЛЕКТОР
 PL DEFLEKTOR TYLNY



3004585

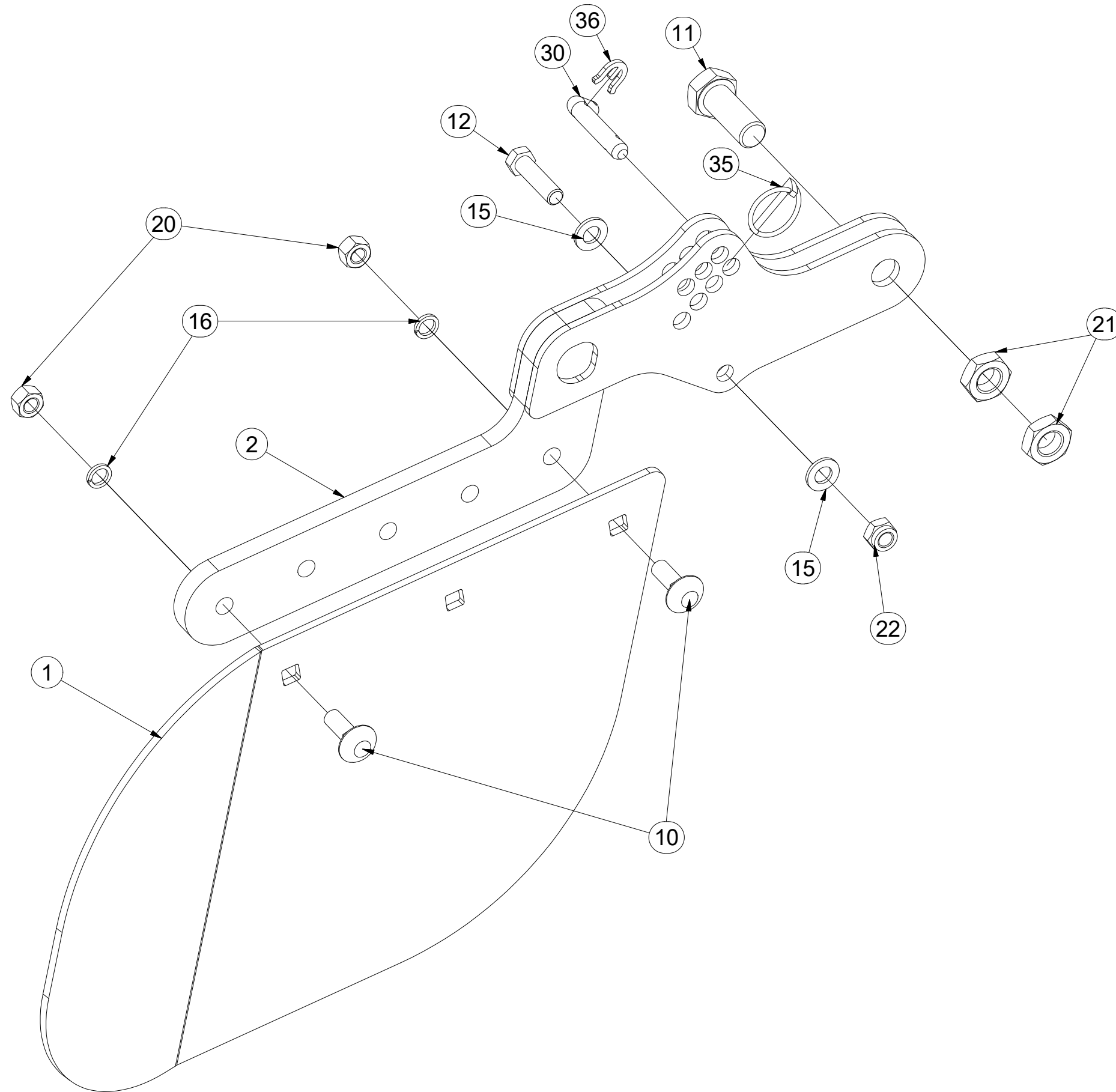

Pos	Part Number	Pcs.
1	4007854	1
2	4008743	1
10	m10618	2
11	m08378	1
12	m06077	1
15	m01214	2
16	m03988	2
20	m10439	2
21	m04284	2
22	m04301	1
30	m09141	1
35	m10454	1
36	4016279	1

ⒸZ DVOUVÁLCE

Ⓓ DUPLEXWALZEN

Ⓕ ROULEAU DOUBLE

3008712

ⒸGB TWIN ROLLERS

ⒸRU ДВОЙНЫЕ КАТКИ

ⒸPL WAŁ PODWÓJNY

Farmet

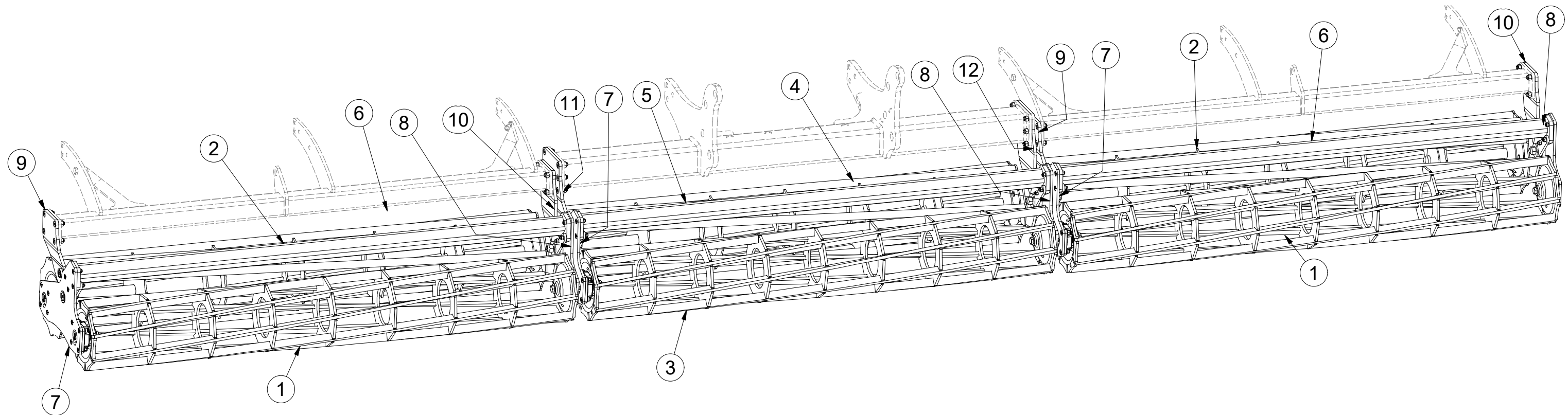

Pos.	Part Number	Pcs.
1	2000759	2
2	3004916	2
3	2000760	1
4	3004920	1
5	3008750	1
6	3008749	2
7	3008728	3
8	3008729	3
9	3008700	2
10	3008702	2
11	3008717	1
12	3008718	1

ⒸZ DVOUVÁLCE

Ⓓ DUPLEXWALZEN

Ⓕ ROULEAU DOUBLE

ⒼB TWIN ROLLERS

ⒺRU ДВОЙНЫЕ КАТКИ

ⒺPL WAŁ PODWÓJNY



3008712

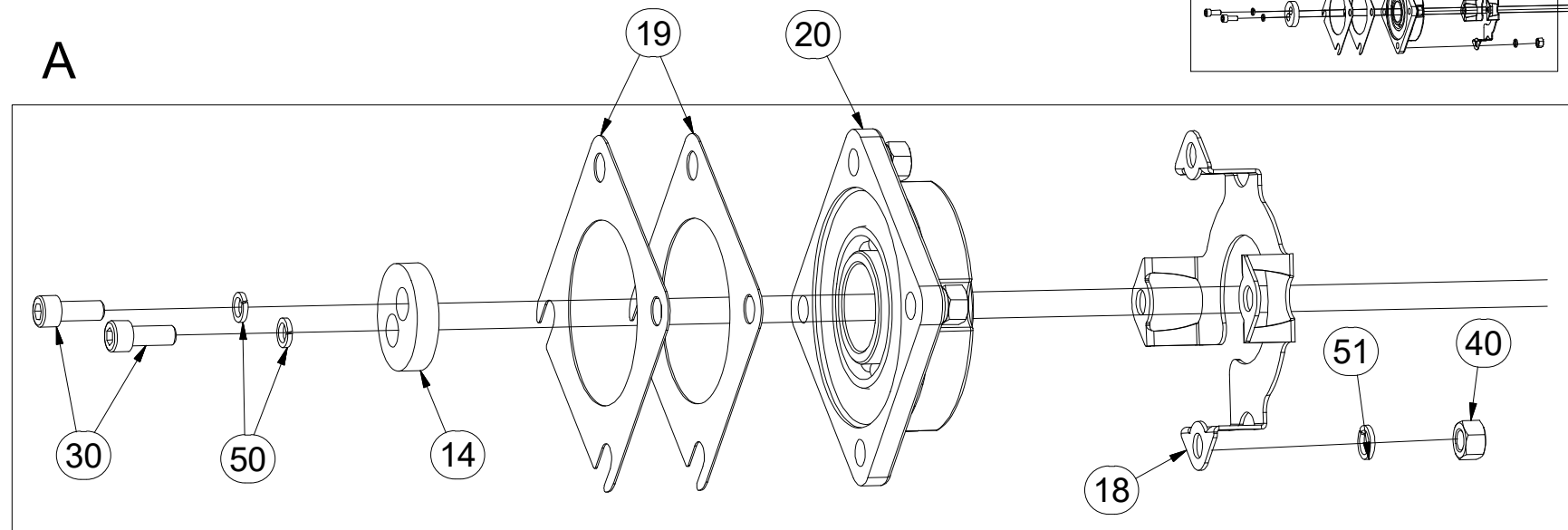
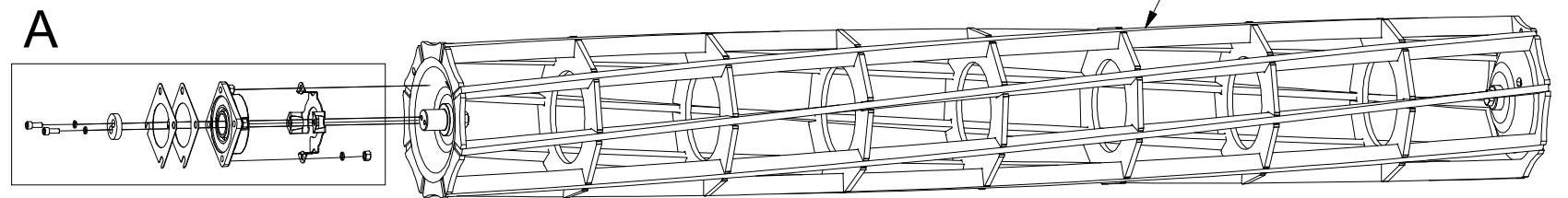
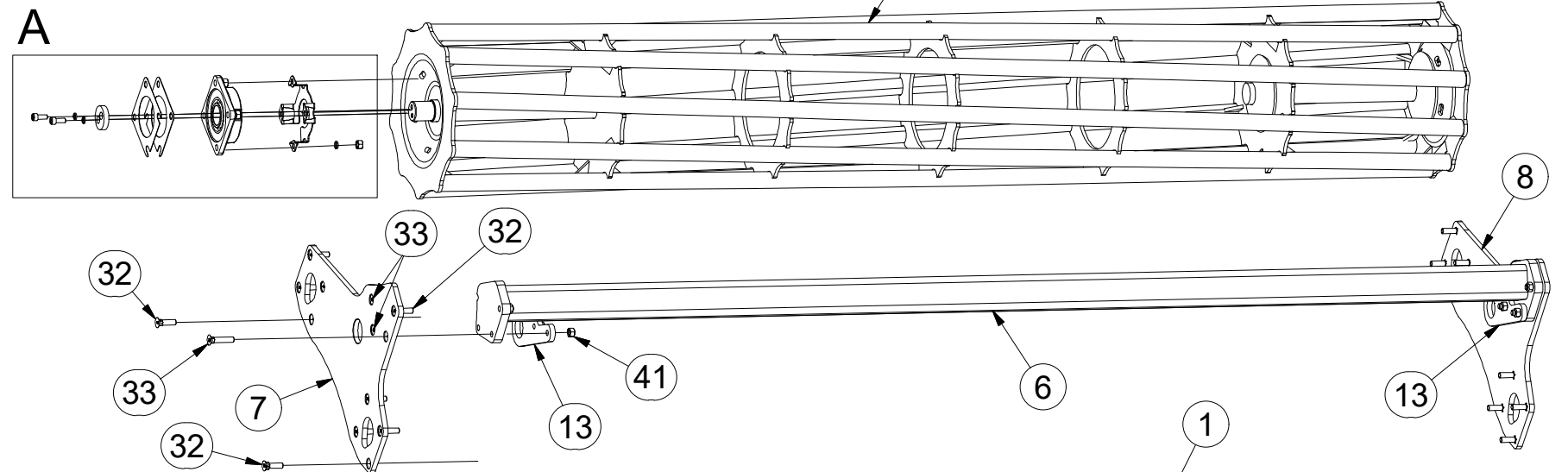
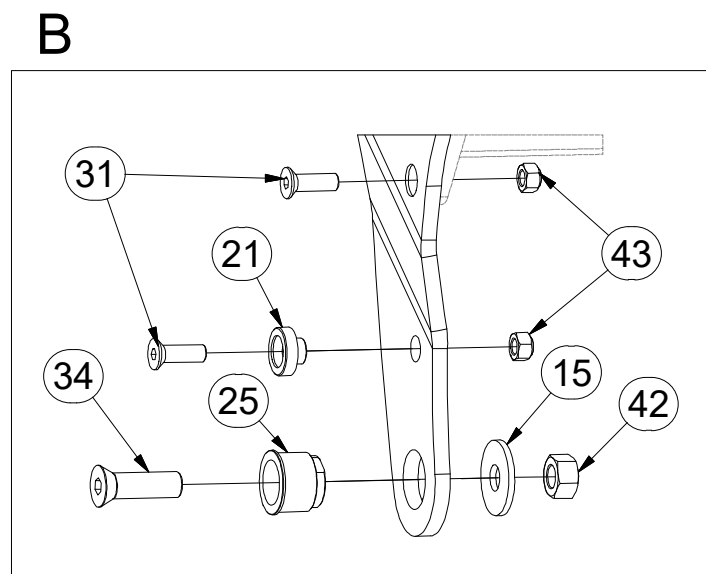
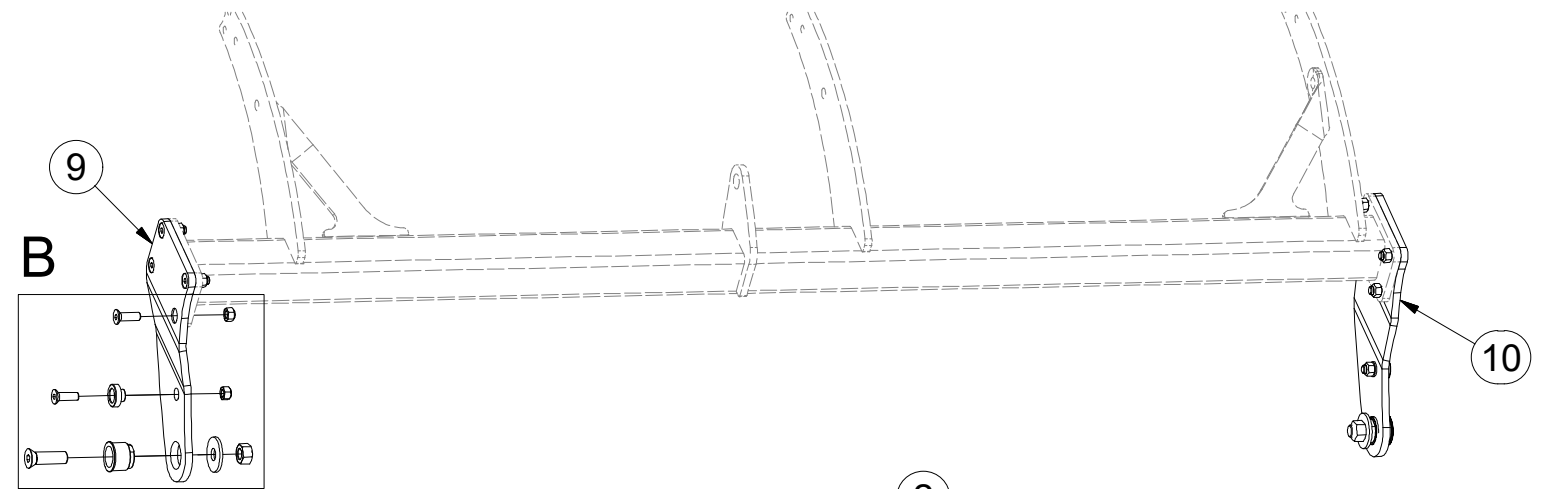
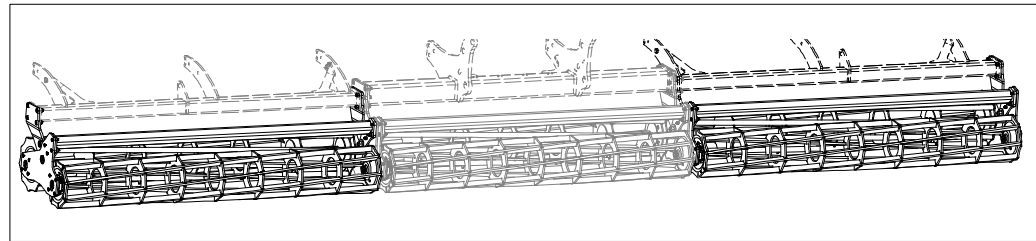

Pos.	Part Number	Pcs.	Pos.	Part Number	Pcs.	Pos.	Part Number	Pcs.
1	2000759	2	15	4015792	6	33	m14993	18
2	3004916	2	18	4017071	12	34	m14992	6
6	3008749	2	19	4016002	24	40	m01305	48
7	3008728	3	20	m15626	12	41	m12134	24
8	3008729	3	21	m15767	6	42	m13009	6
9	3008700	2	25	m14991	6	43	m13846	34
10	3008702	2	30	m04249	24	50	m01208	24
13	4015769	6	31	m14672	34	51	m03988	48
14	4017124	12	32	m11154	54			

ⒸZ DVOUVÁLCE

Ⓓ DUPLEXWALZEN

Ⓕ ROULEAU DOUBLE

ⒼB TWIN ROLLERS

ⒺR ДВОЙНЫЕ КАТКИ

ⒺL WAŁ PODWÓJNY



3008712

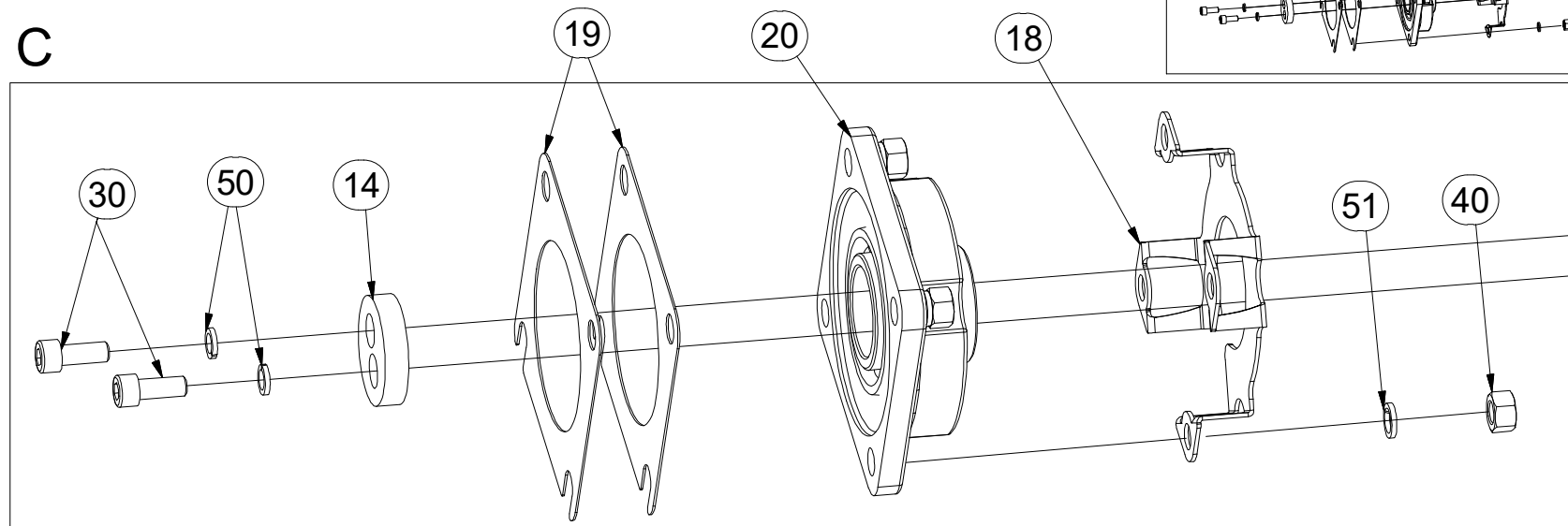
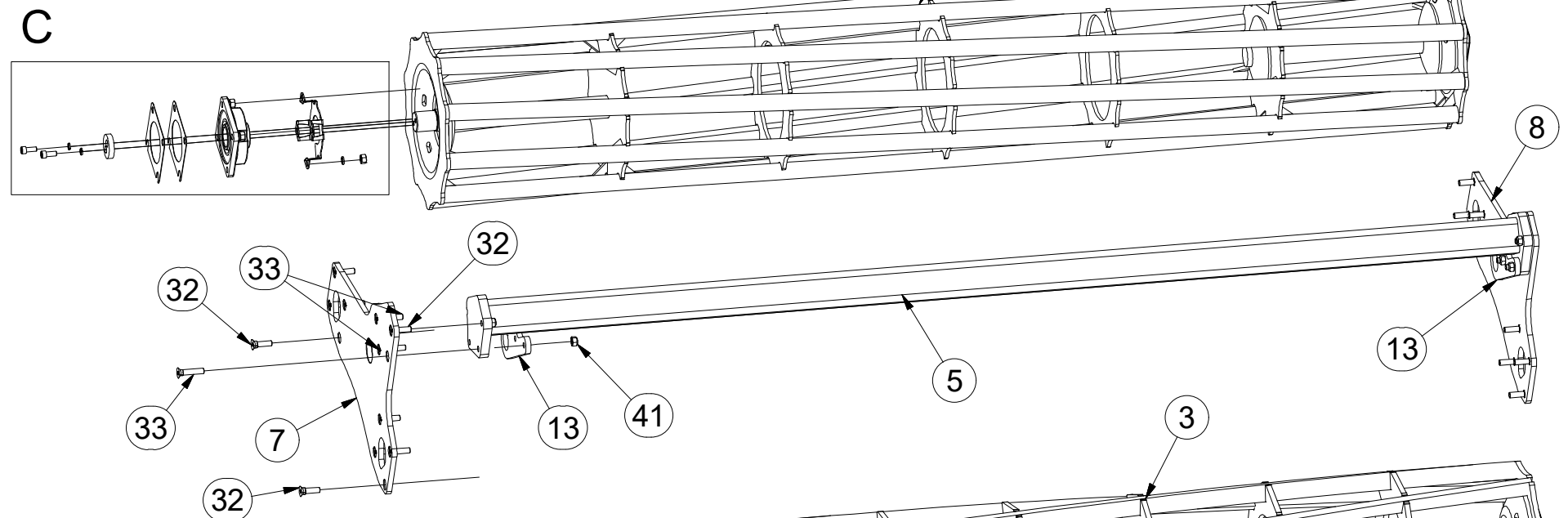
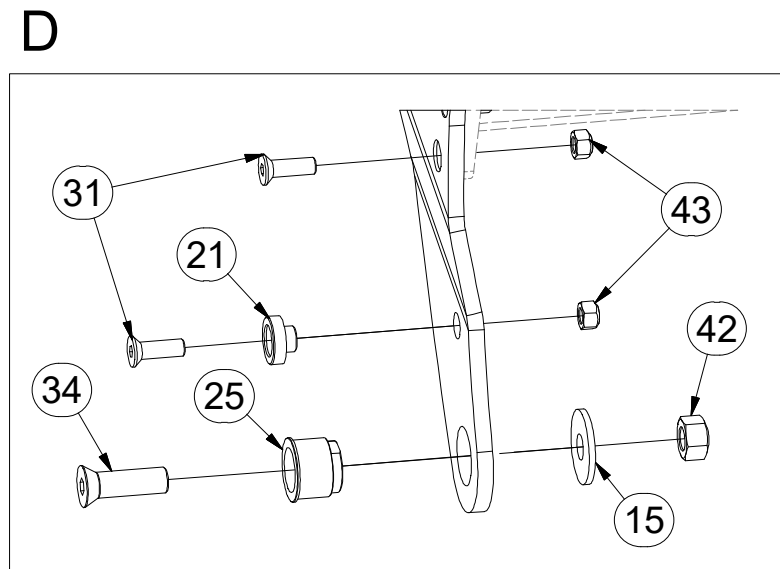
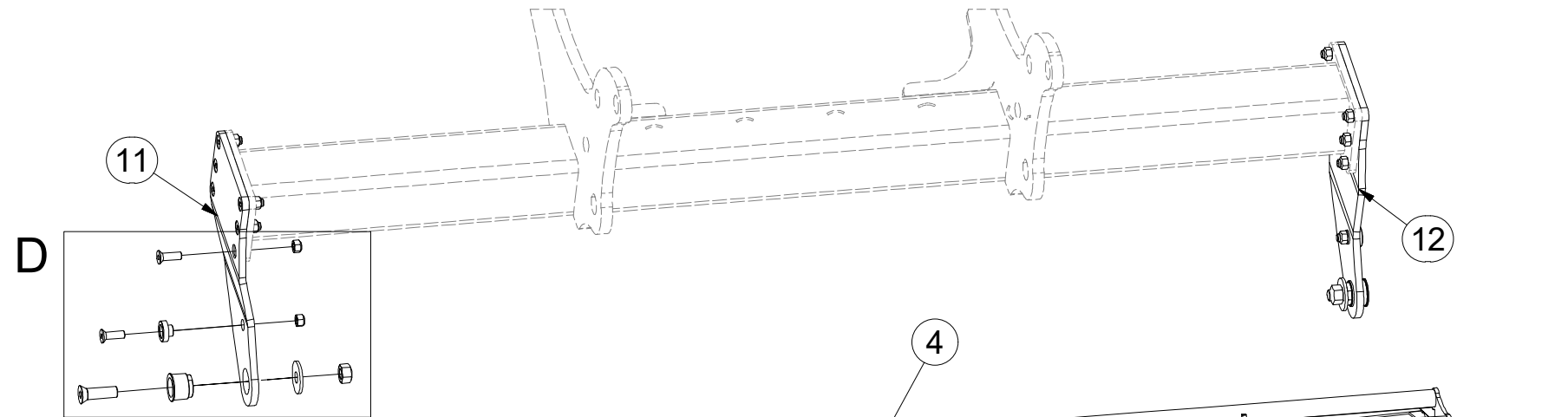
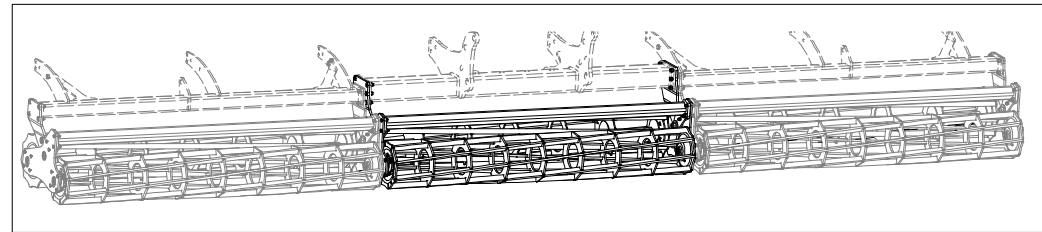

Pos.	Part Number	Pcs.	Pos.	Part Number	Pcs.	Pos.	Part Number	Pcs.
3	2000760	1	15	4015792	6	33	m14993	18
4	3004920	1	18	4017071	12	34	m14992	6
5	3008750	1	19	4016002	24	40	m01305	48
7	3008728	3	20	m15626	12	41	m12134	24
8	3008729	3	21	m15767	6	42	m13009	6
11	3008717	1	25	m14991	6	43	m13846	34
12	3008718	1	30	m04249	24	50	m01208	24
13	4015769	6	31	m14672	34	51	m03988	48
14	4017124	12	32	m11154	54			

ⒸZ NÁPRAVA NEBRŽDĚNÁ

Ⓓ NICHT GEBREMSTE ACHSE

Ⓕ ESSIEU NON FREINÉ

ⒸB AXLE WITHOUT BRAKES

ⒸU OČЬ BE3 TOPMO3A

ⒸL OŚ NIEHAMOWANA



3008113

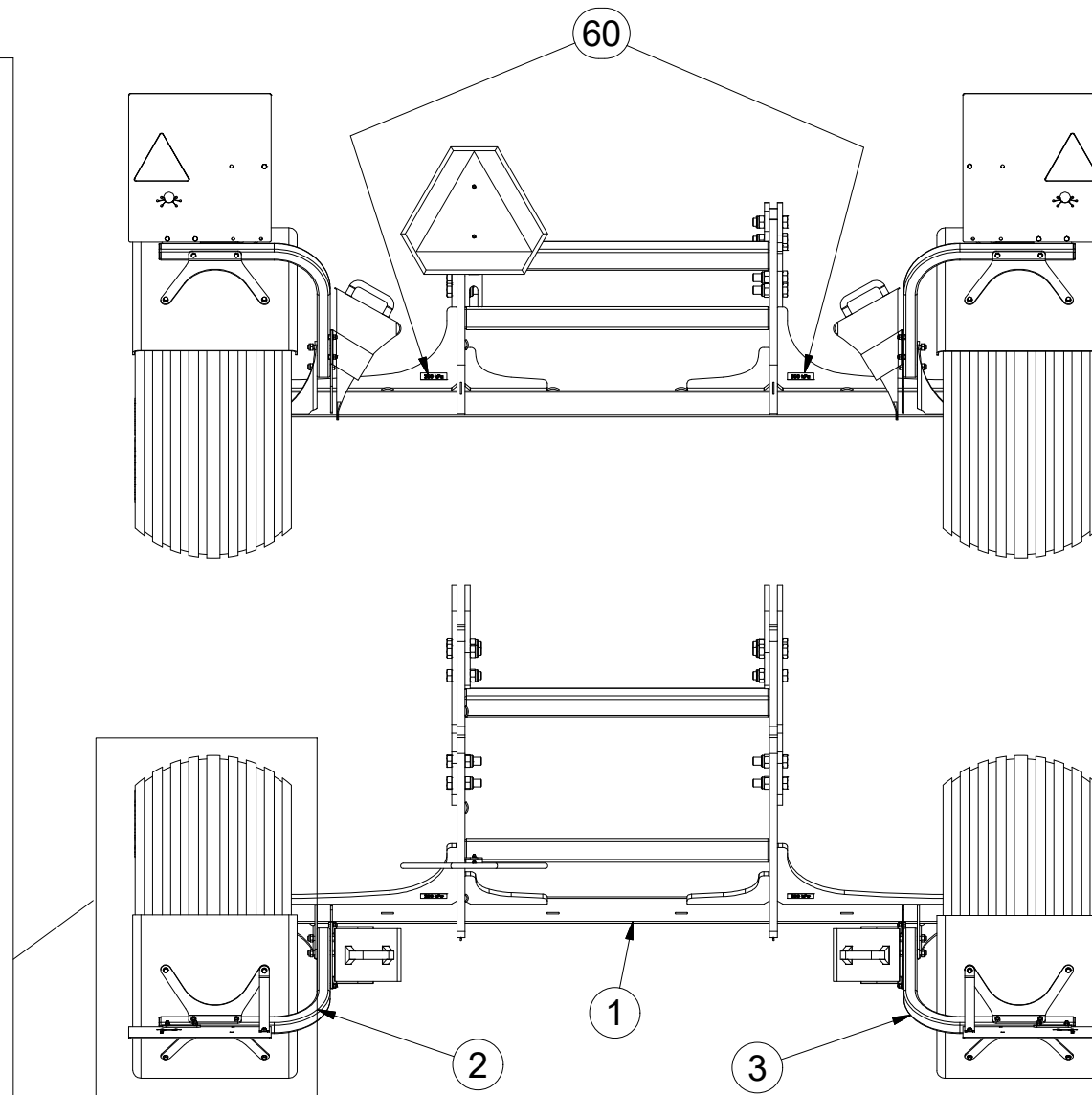
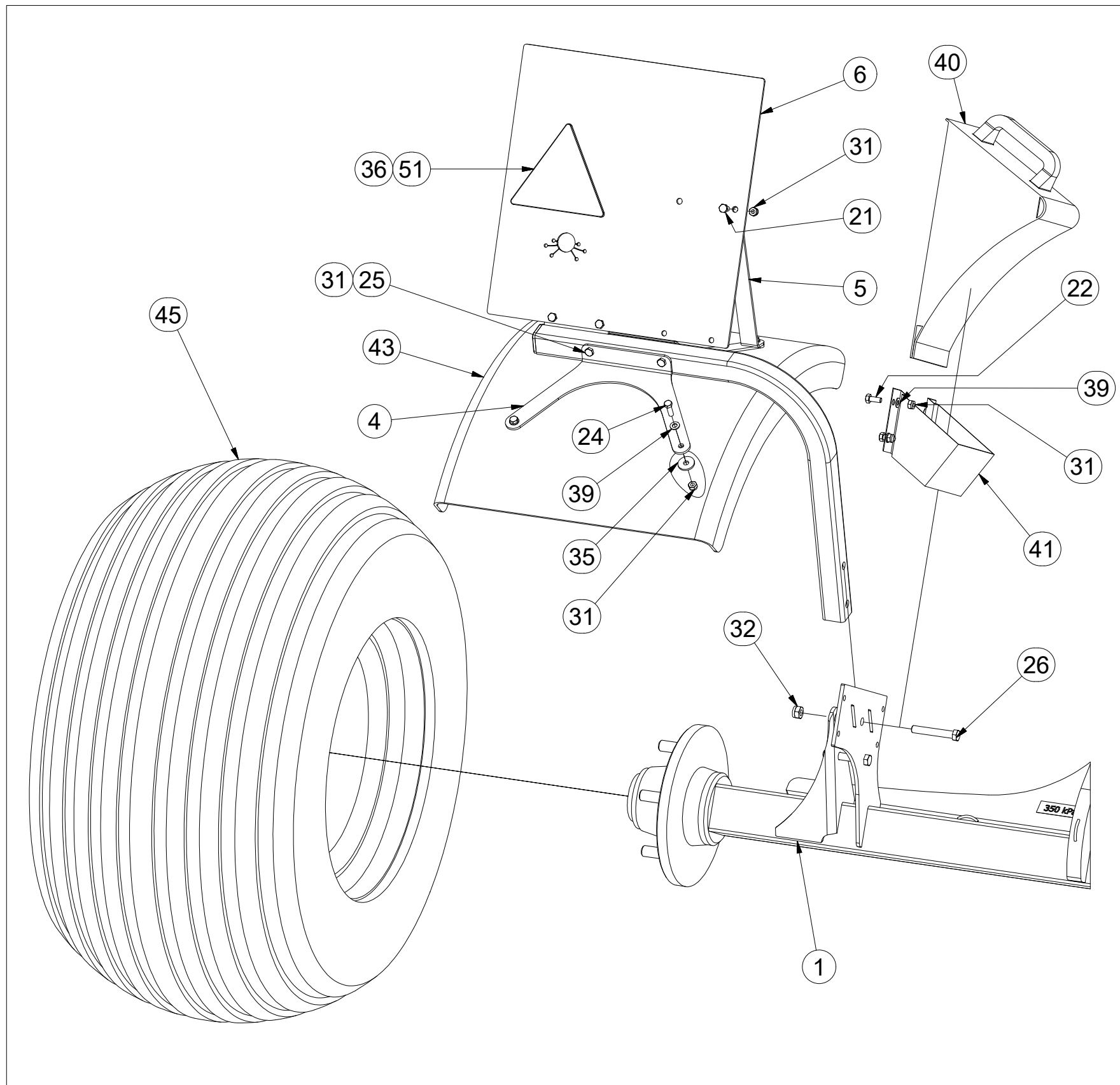

	M6 (8.8) - 10Nm
	M8 (8.8) - 25Nm
	M12 (8.8) - 87Nm
	M20x1,5-343Nm
	350 kPa

Pos.	Part Number	Pcs.	Pos.	Part Number	Pcs.
1	2000795	1	31	m04503	26
2	3007289	1	32	m06233	4
3	3007290	1	35	m07936	8
4	4014027	4	36	m01197	4
5	4014030	2	39	m01203	16
6	4014031	2	40	m16186	2
21	m04553	2	41	m12572	2
22	m01089	8	43	m09983	2
24	m01092	8	45	m14895	2
25	m14355	4	51	m02497	2
26	m12493	4	60	m08845	2

Ⓒ NÁPRAVA NEBRŽDĚNÁ

Ⓓ NICHT GEBREMSTE ACHSE

Ⓕ ESSIEU NON FREINÉ

Ⓖ AXLE WITHOUT BRAKES

Ⓡ ОСЬ БЕЗ ТОПМОЗА

Ⓟ ОŚ NIEHAMOWANA



3008113

Pos.	Part Number	Pcs.
1	2000795	1
7	4014698	2
8	4014700	2
20	m01073	2
23	m01090	4
27	m14495	10
30	m01295	2
31	m04503	26
33	m07147	10
37	m01200	2
38	m01202	4
50	m05371	1
55	m12689	2

Part Number	Quantity
M5 (8.8) - 6Nm	2
M6 (8.8) - 10Nm	2
M8 (8.8) - 25Nm	4
M12 (8.8) - 87Nm	2

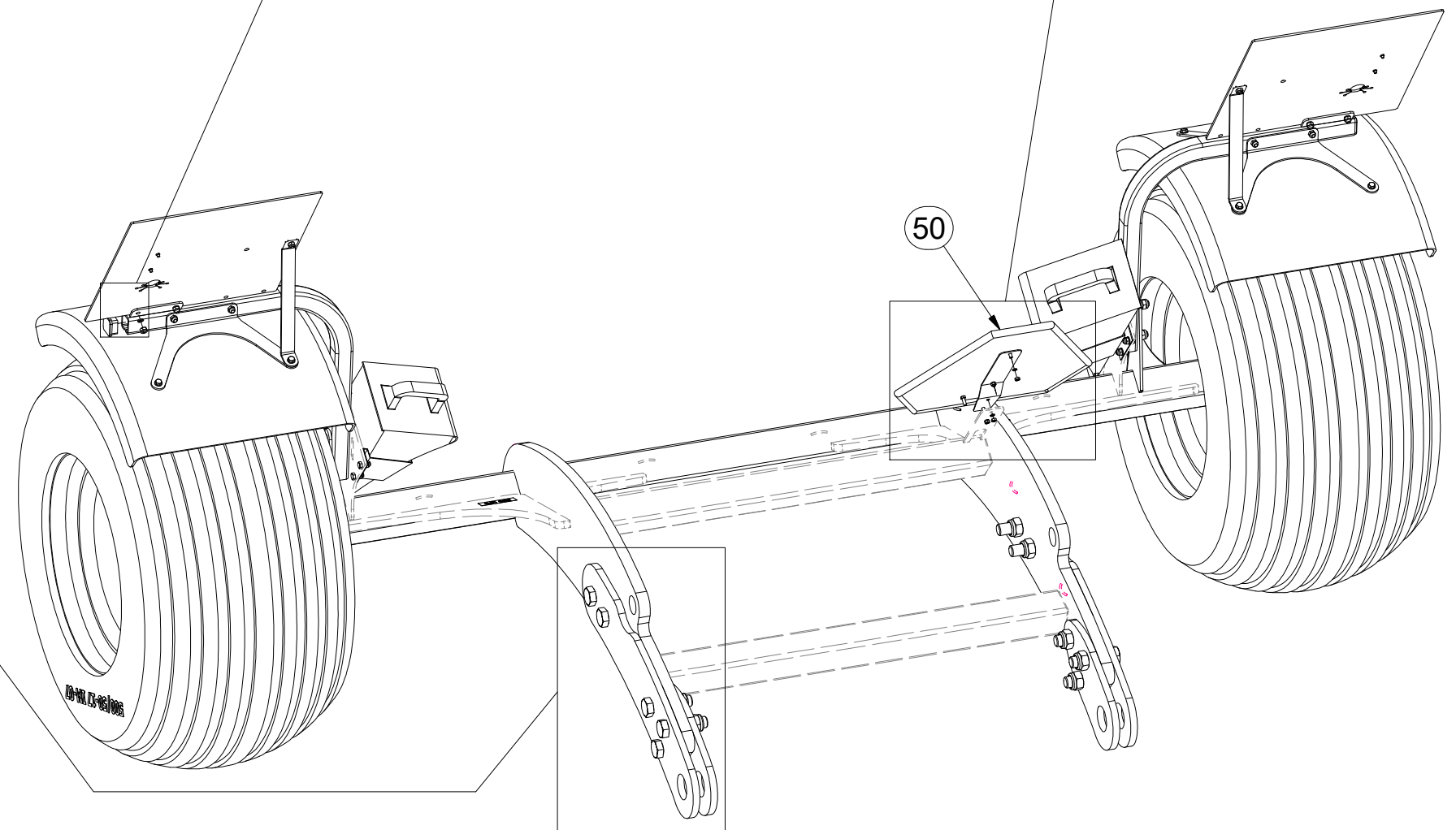
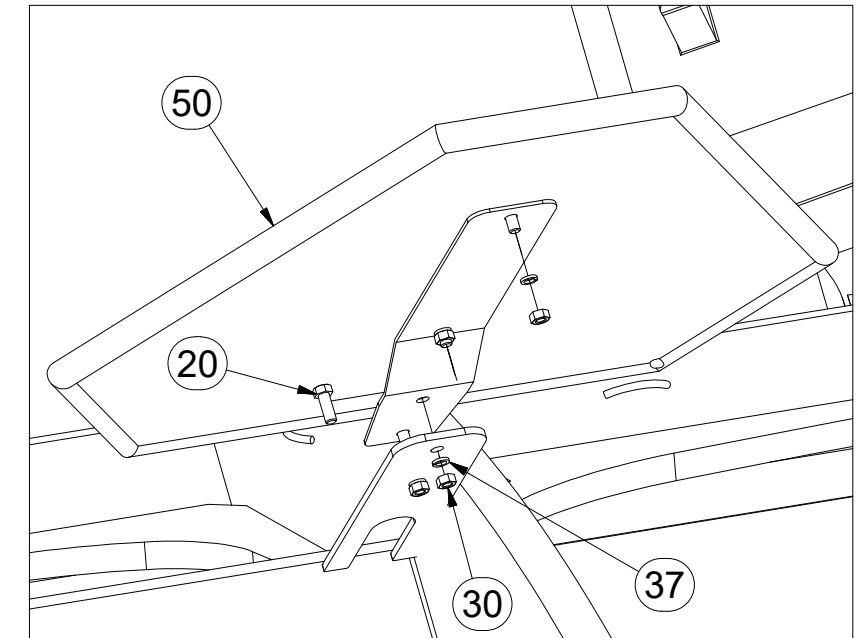
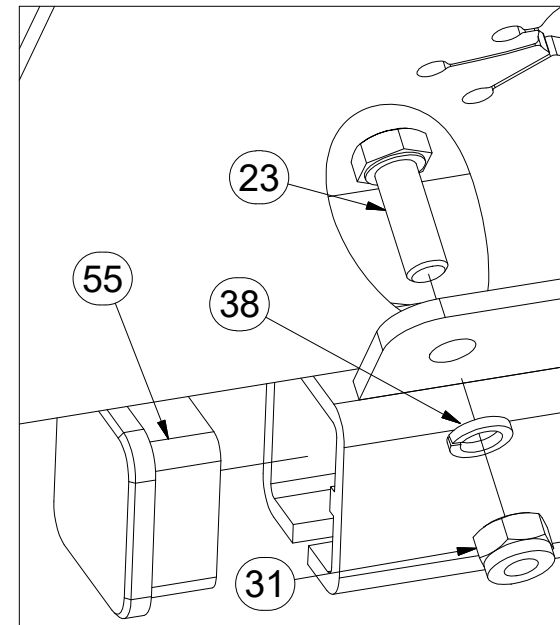
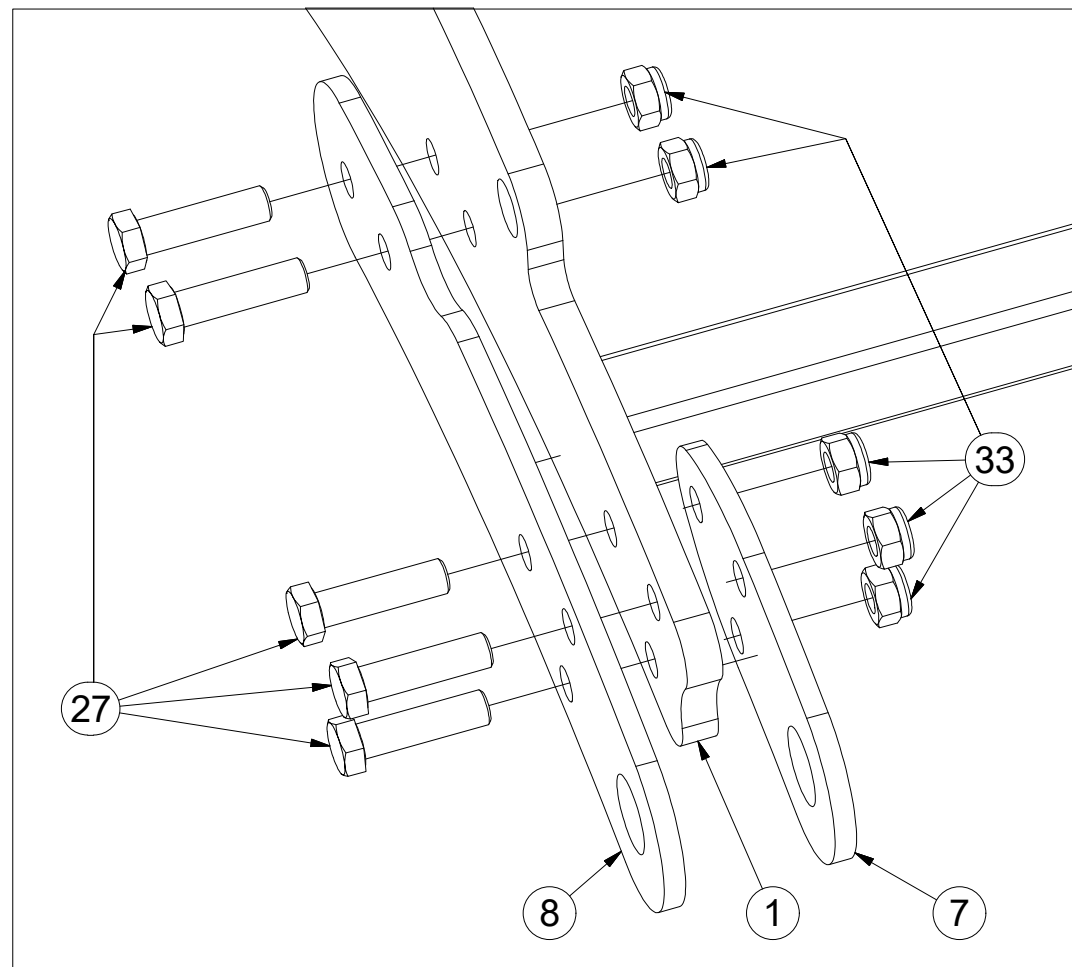

ⒸZ NÁPRAVA NEBRŽDĚNÁ

Ⓓ NICHT GEBREMSTE ACHSE

Ⓕ ESSIEU NON FREINÉ

ⒸB AXLE WITHOUT BRAKES

ⒸU OЦЬ BE3 TOPMO3A

ⒸL OŚ NIEHAMOWANA



3008113

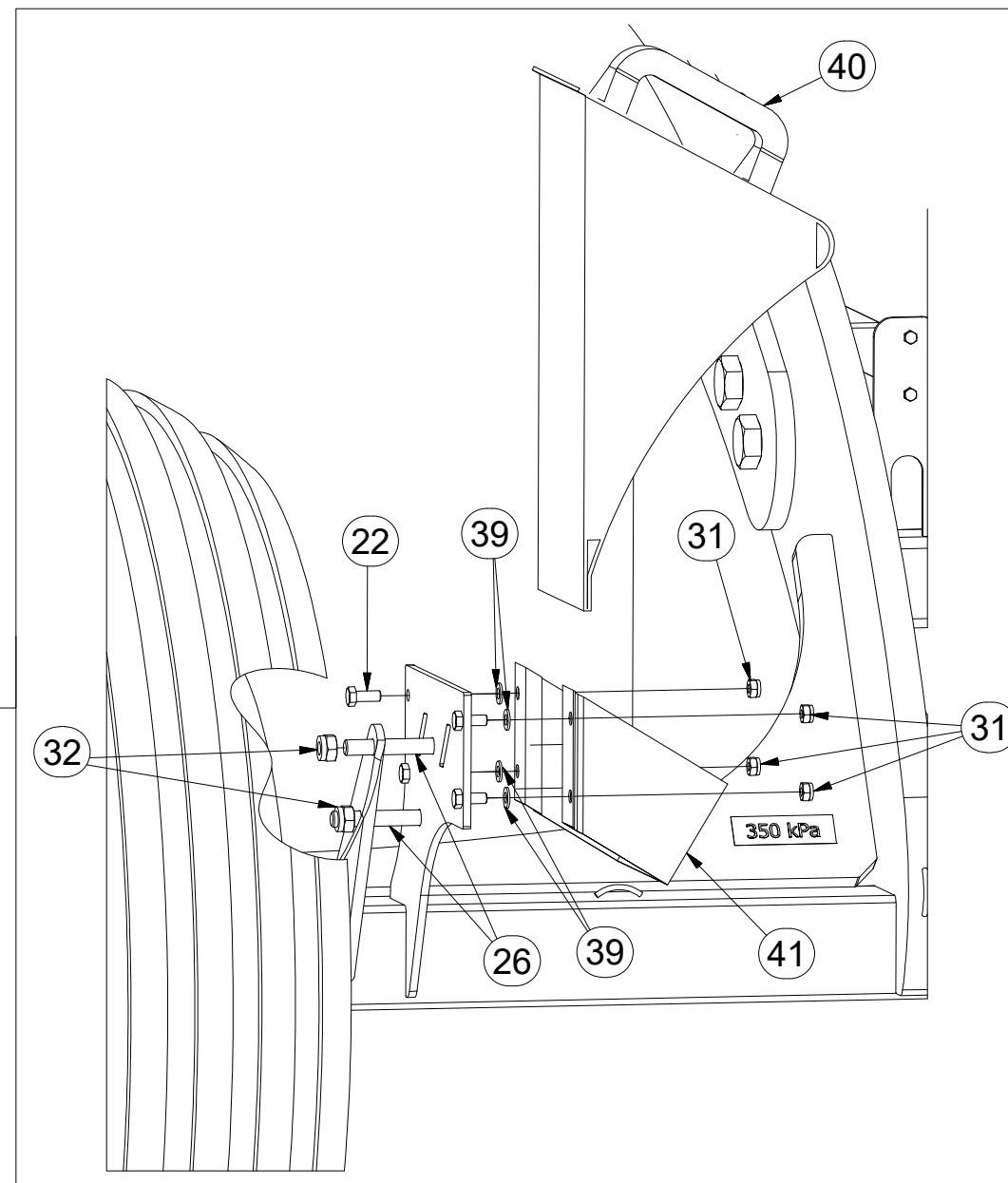
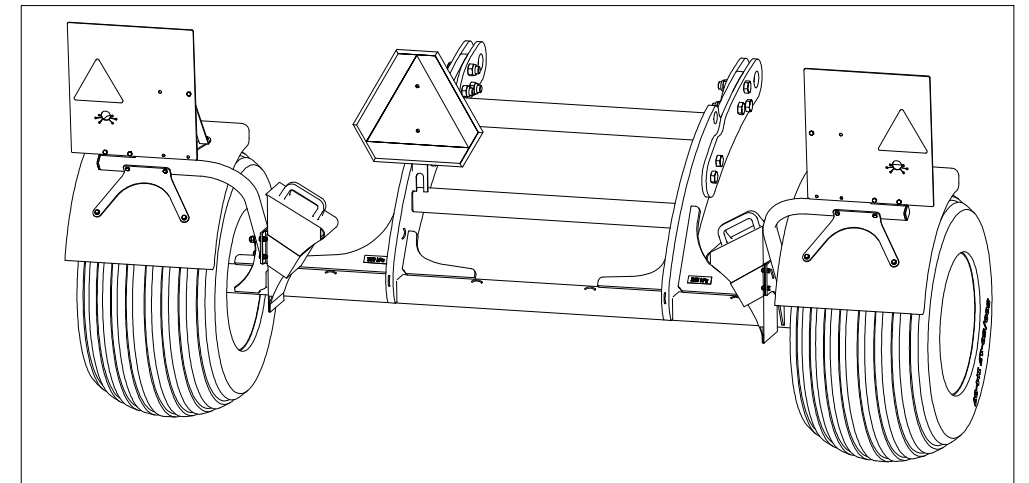
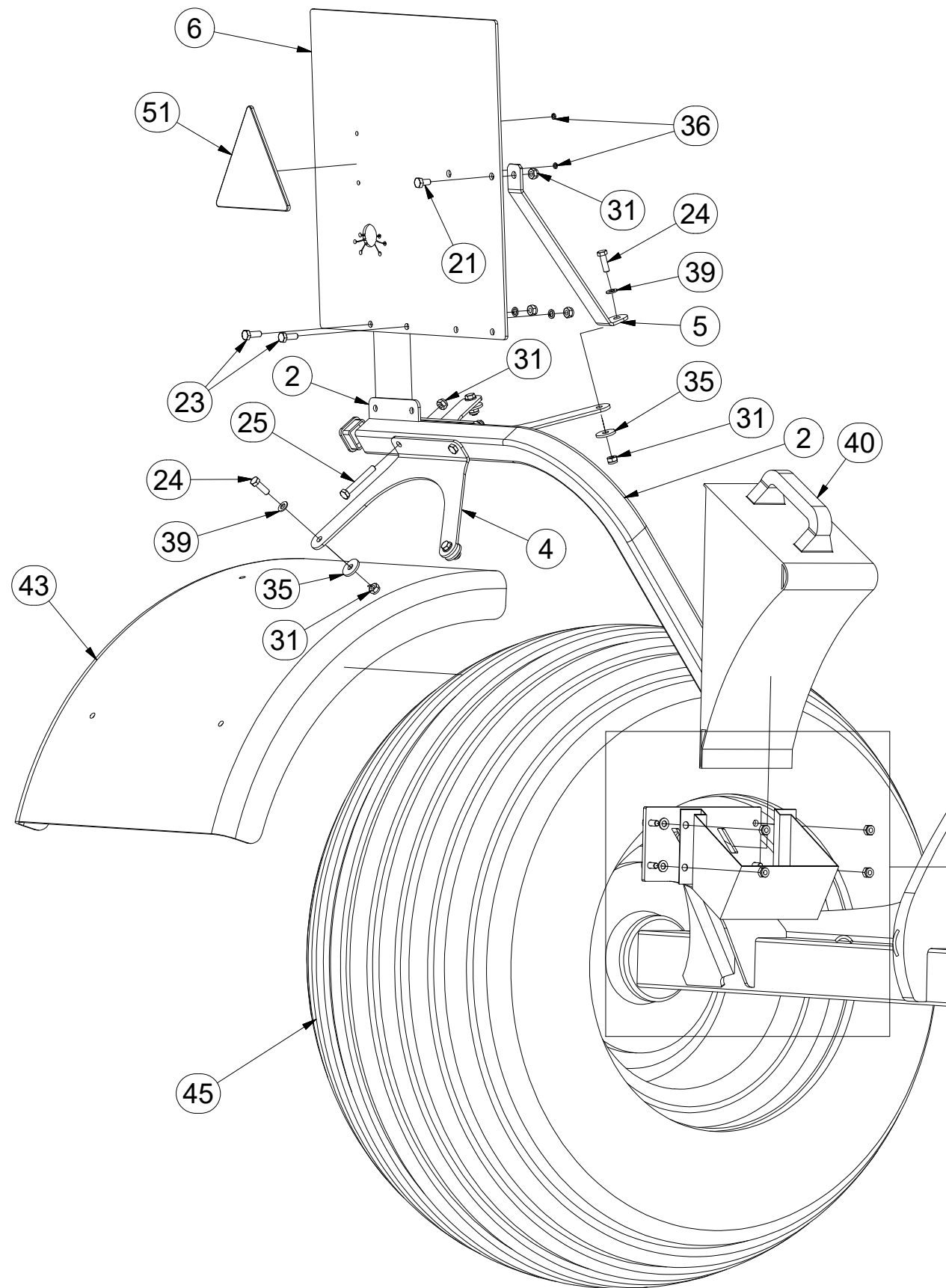

Pos.	Part Number	Pcs.
1	2000795	1
2	3007289	1
4	4014027	4
5	4014030	2
6	4014031	2
21	m04553	2
22	m01089	8
24	m01092	8
25	m14355	4
26	m12493	4
31	m04503	26
32	m06233	4
35	m07936	8
36	m01197	4
39	m01203	16
40	m16186	2
41	m12572	2
43	m09983	2
45	m14895	2
51	m02497	2

Ⓒ NÁPRAVA

Ⓓ ACHSE

Ⓕ ESSIEU

Ⓖ AXLE

Ⓒ OCB

Ⓕ OS



A80RM600

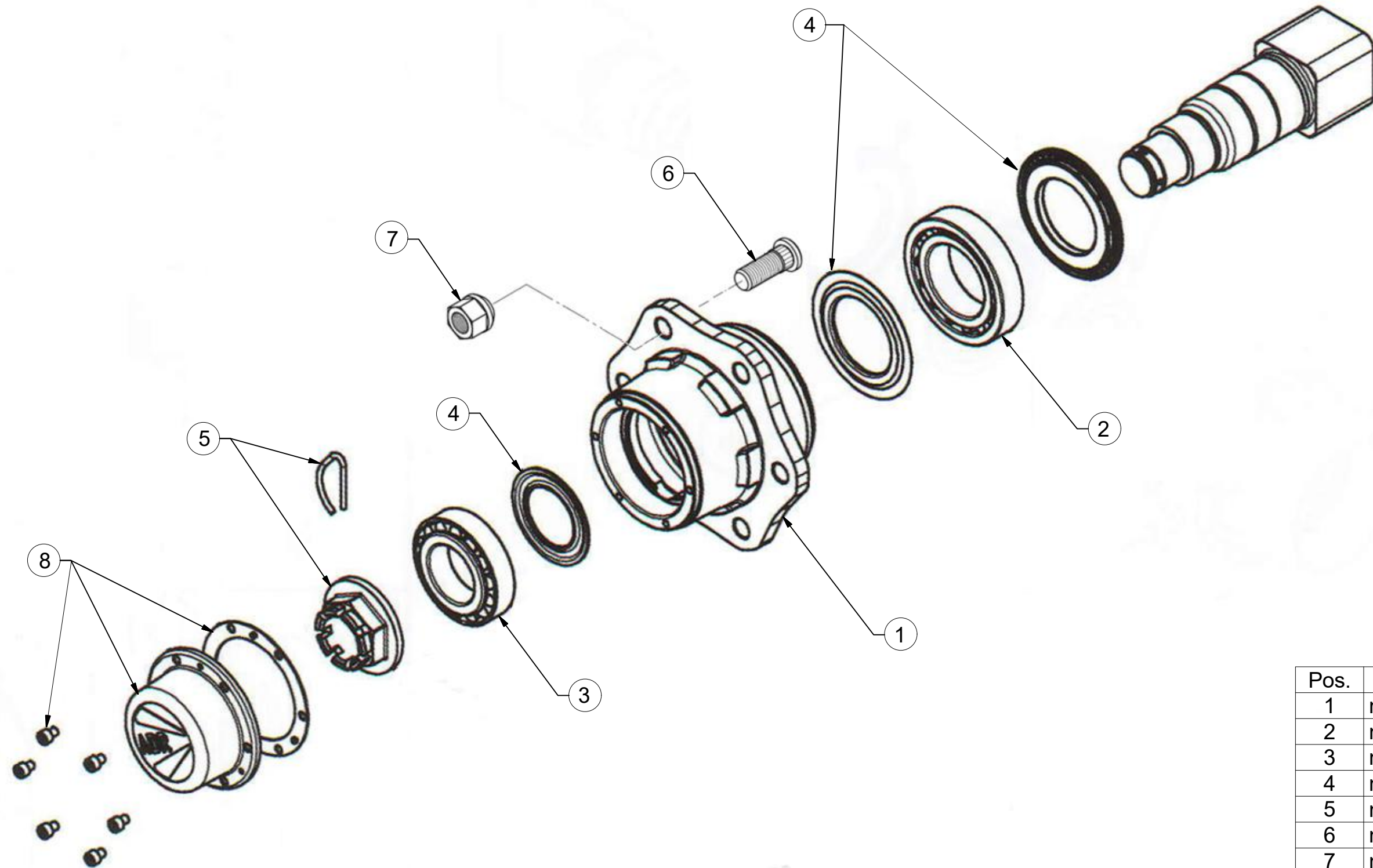

Pos.	Part Number	Pcs.
1	m12567	1
2	m07153	1
3	m07154	1
4	m12565	1
5	m08168	1
6	m08148	6
7	m08163	6
8	m12566	1

ⒸZ HYDRAULICKÝ ROZVOD NÁPRAVY

Ⓓ HYDRAULISCHE VERTEILUNG ACHSE

Ⓕ CONDUIT HYDRAULIQUE DE L'ESSIEU

ⒸB HYDRAULIC AXLE DISTRIBUTION

ⒸR ГИДРАВЛИЧЕСКОЕ РАСПРЕДЕЛЕНИЕ ОСИ

ⒸL HYDRAULICZNY PRZEWÓD OSI



3004418

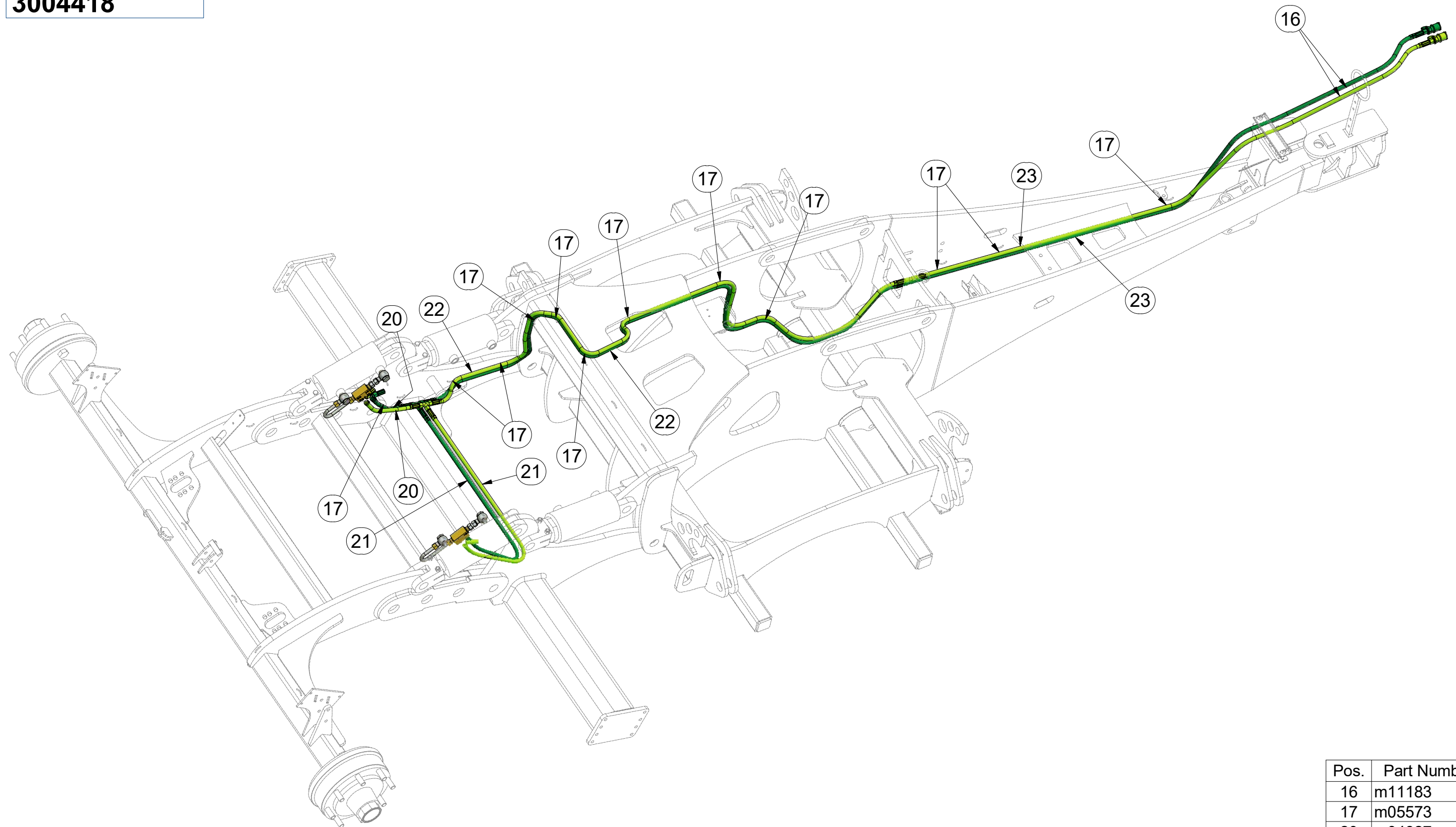

Pos.	Part Number	Pcs.
16	m11183	1
17	m05573	30
20	m04827	2
21	m03952	2
22	m08526	2
23	m05221	2

ⒸZ HYDRAULICKÝ ROZVOD NÁPRAVY

Ⓓ HYDRAULISCHE VERTEILUNG ACHSE

Ⓕ CONDUIT HYDRAULIQUE DE L'ESSIEU

ⒸB HYDRAULIC AXLE DISTRIBUTION

ⒸU ГИДРАВЛИЧЕСКОЕ РАСПРЕДЕЛЕНИЕ ОСИ

ⒸL HYDRAULICZNY PRZEWÓD OSI



3004418

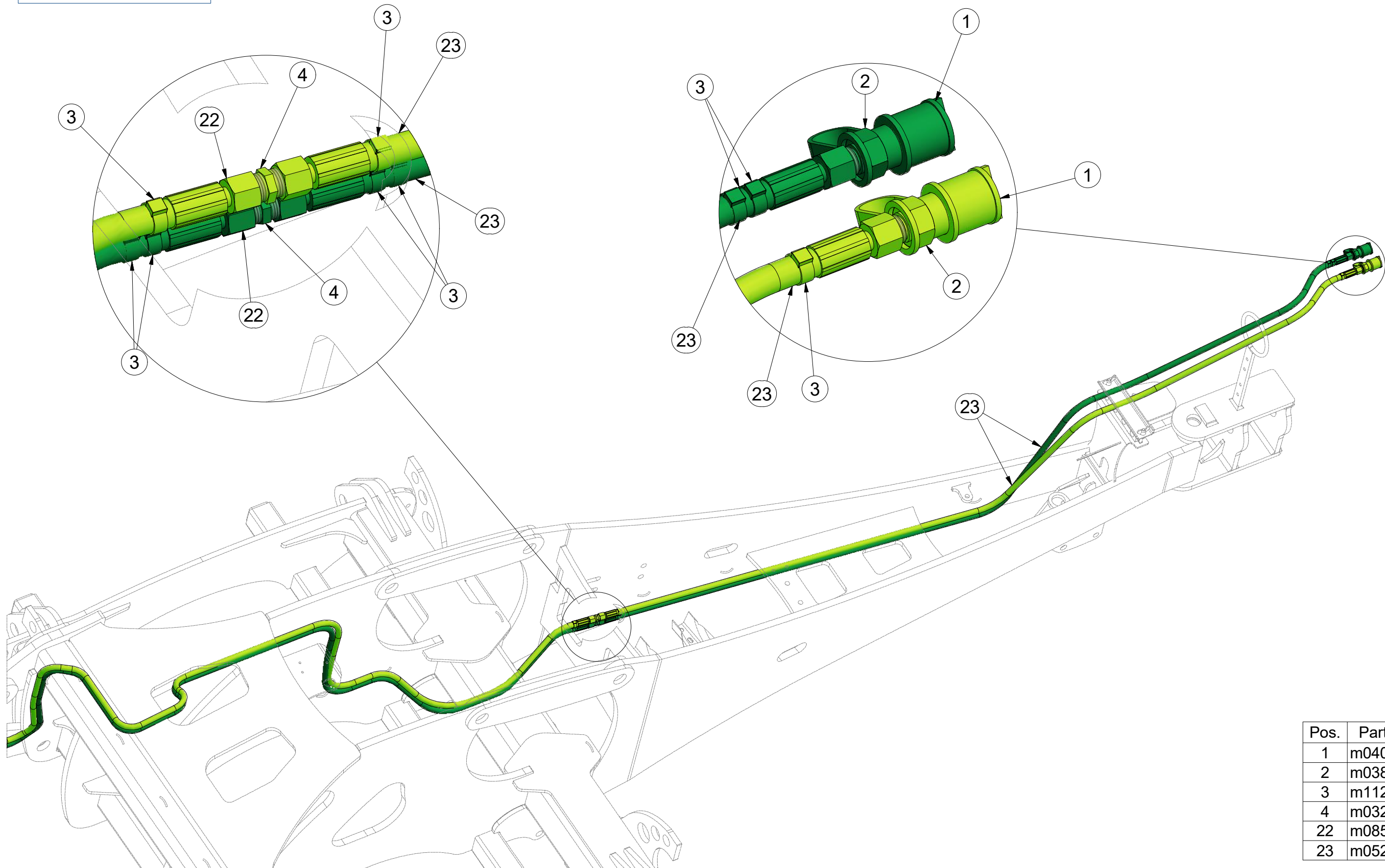

Pos.	Part Number	Pcs.
1	m04098	2
2	m03849	2
3	m11282	24
4	m03213	2
22	m08526	2
23	m05221	2

ⒸZ HYDRAULICKÝ ROZVOD NÁPRAVY

Ⓓ HYDRAULISCHE VERTEILUNG ACHSE

Ⓕ CONDUIT HYDRAULIQUE DE L'ESSIEU

ⒼB HYDRAULIC AXLE DISTRIBUTION

Ⓔ RU ГИДРАВЛИЧЕСКОЕ РАСПРЕДЕЛЕНИЕ ОСИ

Ⓗ PL HYDRAULICZNY PRZEWÓD OSI



3004418

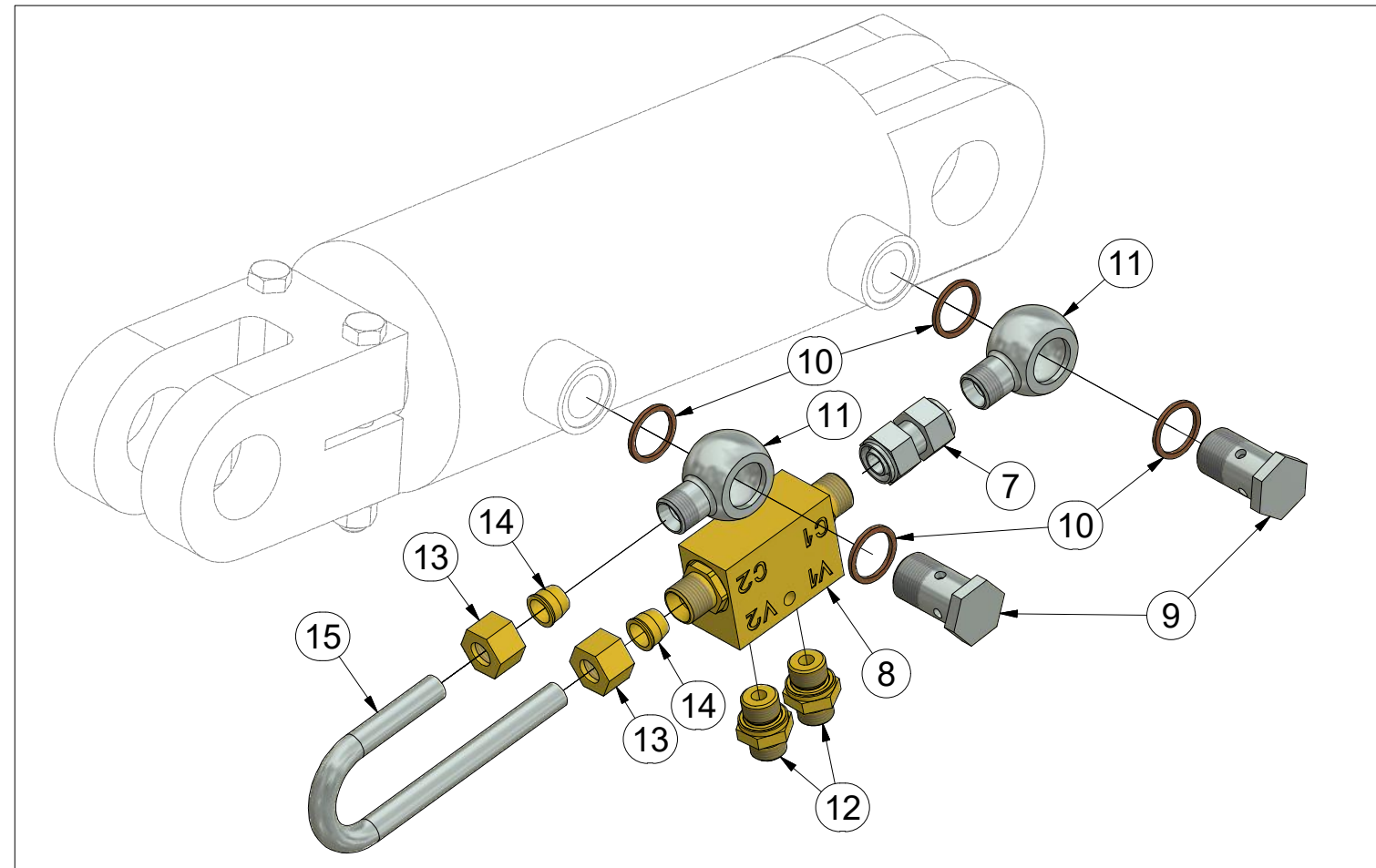

Pos.	Part Number	Pcs.
3	m11282	24
5	m03889	2
7	m05144	2
8	m08083	2
9	m02609	4
10	m04223	8
11	m08860	4
12	m06528	4
13	m08861	4
14	m08862	4
15	m09658	2
20	m04827	2
21	m03952	2
22	m08526	2

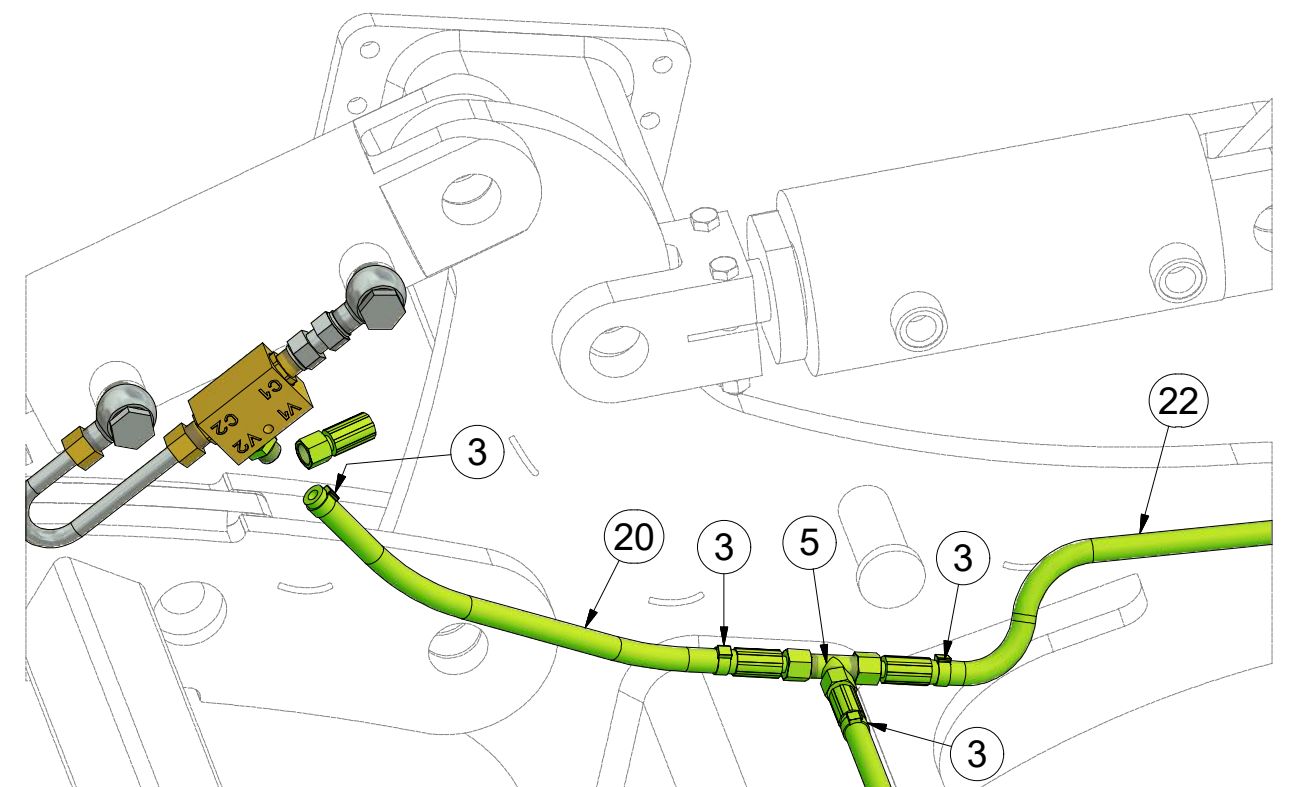
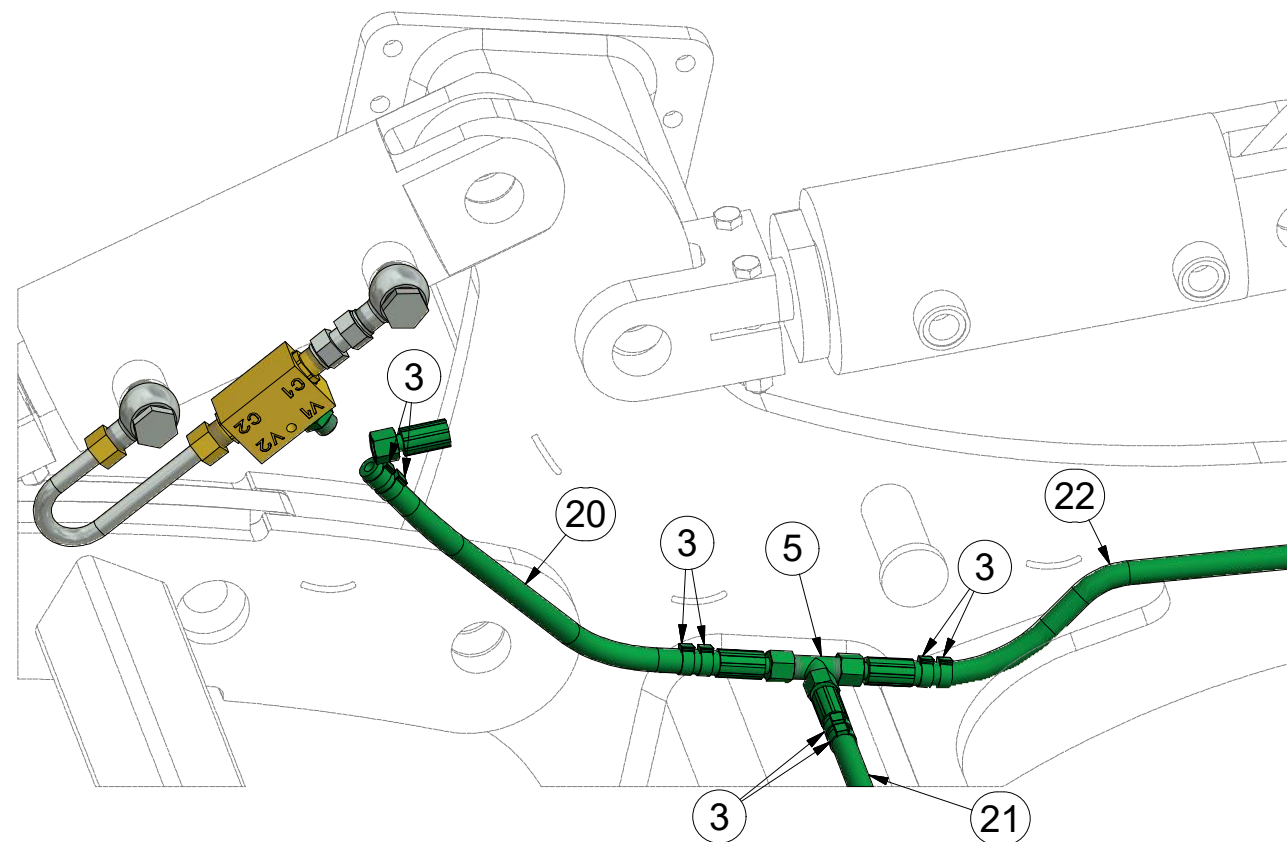

ⒸZ HYDRAULICKÝ ROZVOD VÁLCŮ

Ⓓ HYDRAULISCHE VERTEILUNG WALZEN

Ⓕ CONDUIT HYDRAULIQUE DES ROULEAUX

ⒸB HYDRAULIC ROLLER DISTRIBUTION

ⒸR ГИДРАВЛИЧЕСКОЕ РАСПРЕДЕЛЕНИЕ ЦИЛИНДРОВ

ⒸL HYDRAULICZNY PRZEWÓD WAŁÓW



3004950

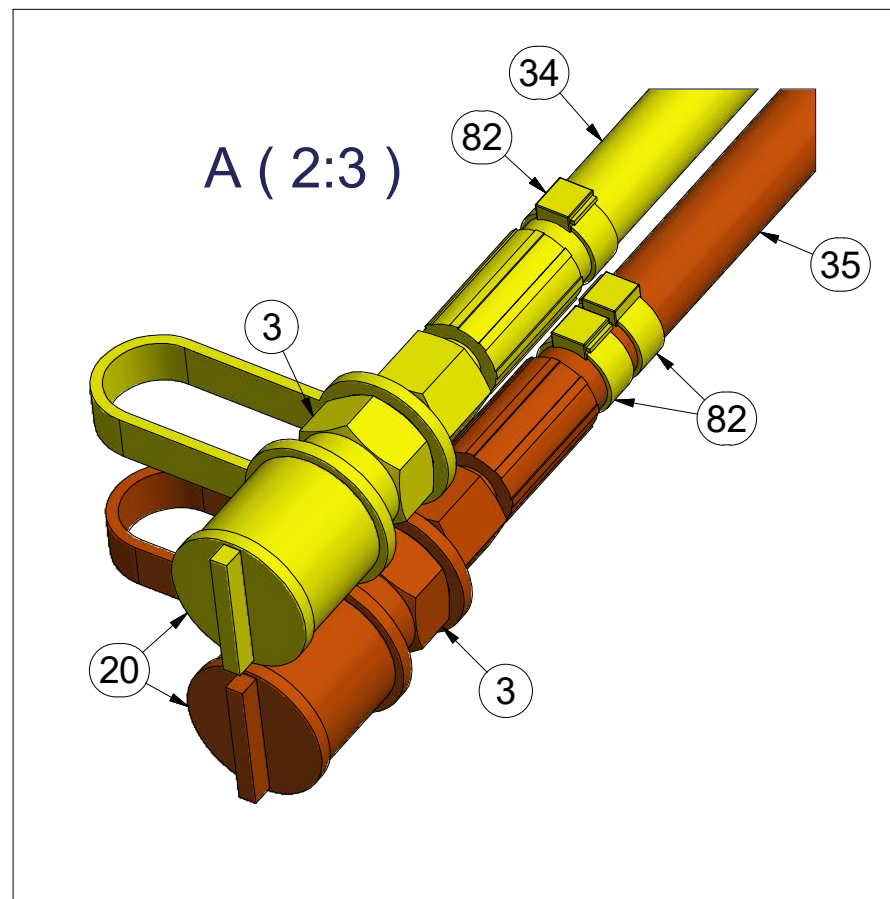
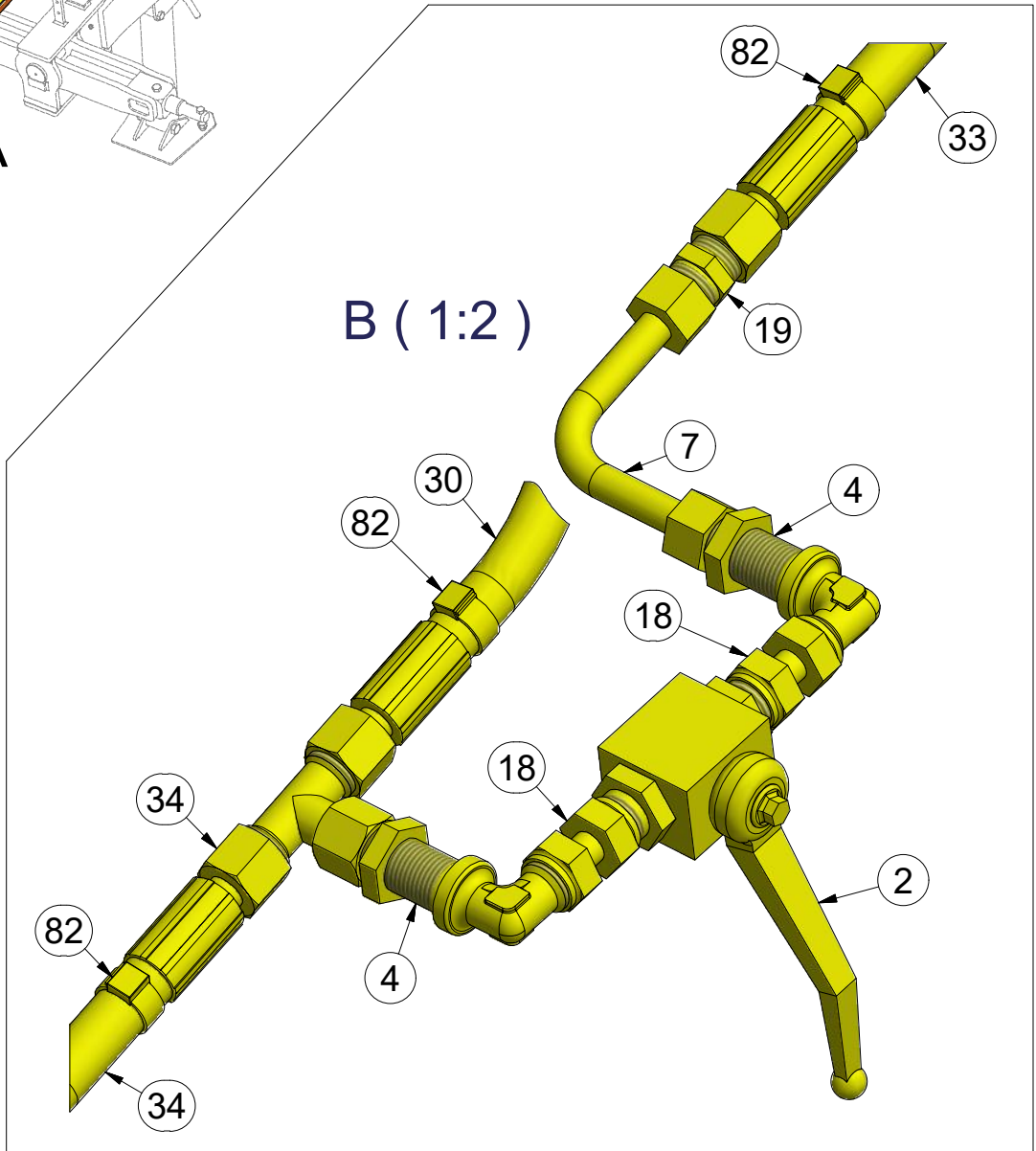
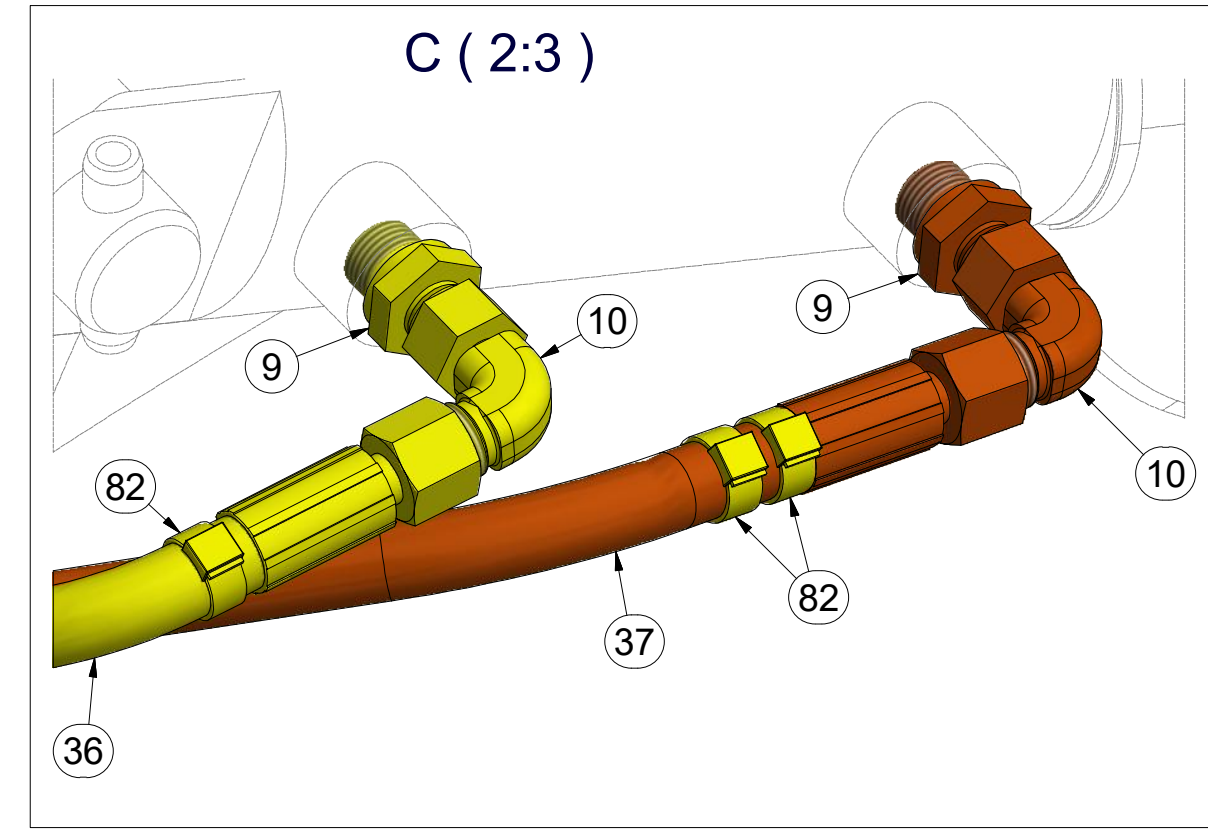

Pos.	Part Number	Pcs.
2	m04623	1
3	m03849	2
4	m08391	2
7	m10493	1
9	m07906	4
10	m06803	8
18	m05212	2
19	m03213	1
20	m04023	2
30	m04761	1
33	m04181	1
34	m09036	1
35	m05216	1
36	m04752	2
37	m09431	2
82	m11289	38

Ⓒ HYDRAULICKÝ ROZVOD VÁLCŮ

Ⓓ HYDRAULISCHE VERTEILUNG WALZEN

Ⓔ CONDUIT HYDRAULIQUE DES ROULEAUX

Ⓖ HYDRAULIC ROLLER DISTRIBUTION

Ⓡ ГИДРАВЛИЧЕСКОЕ РАСПРЕДЕЛЕНИЕ ЦИЛИНДРОВ

Ⓟ HYDRAULICZNY PRZEWÓD WAŁÓW



3004950

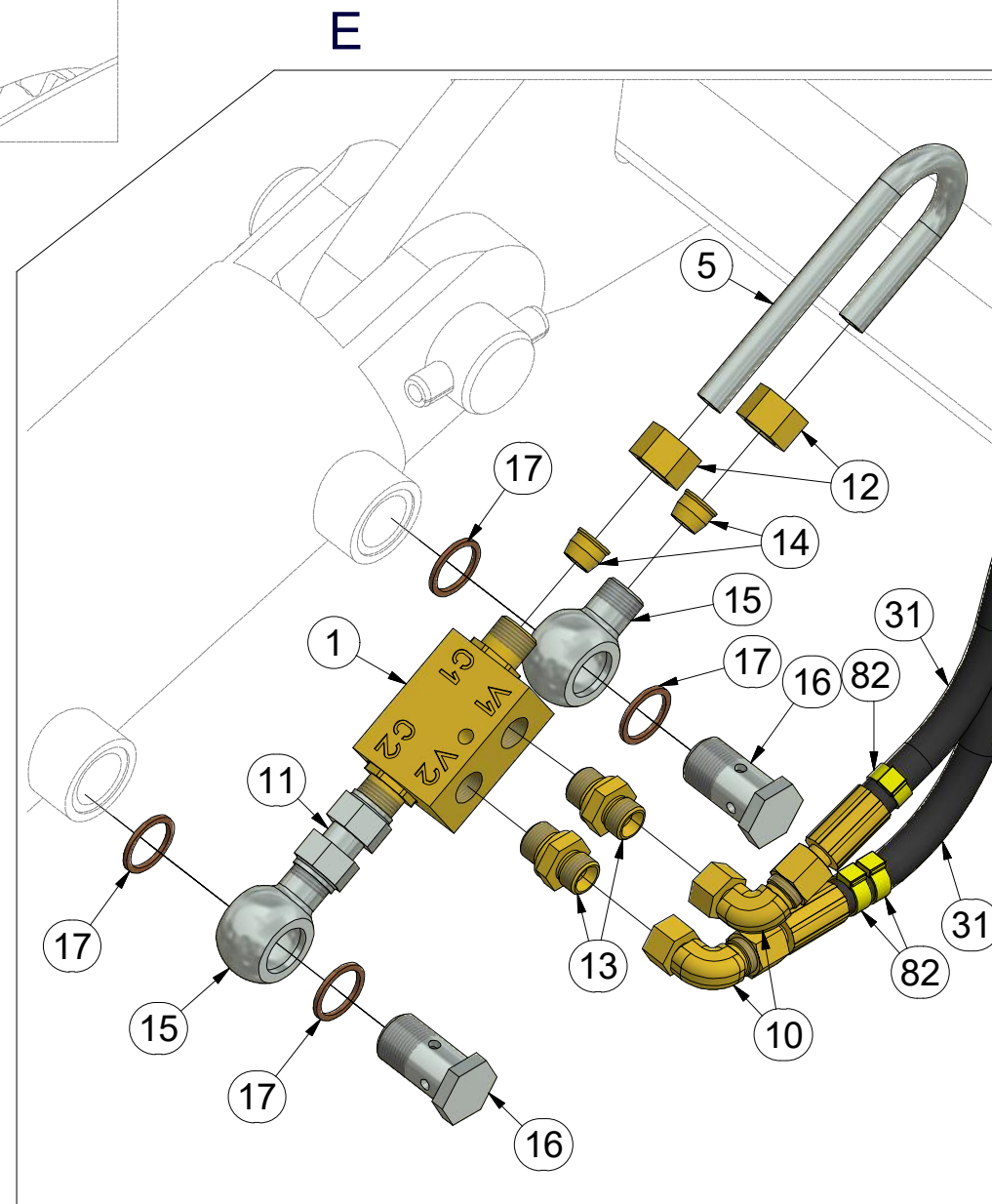
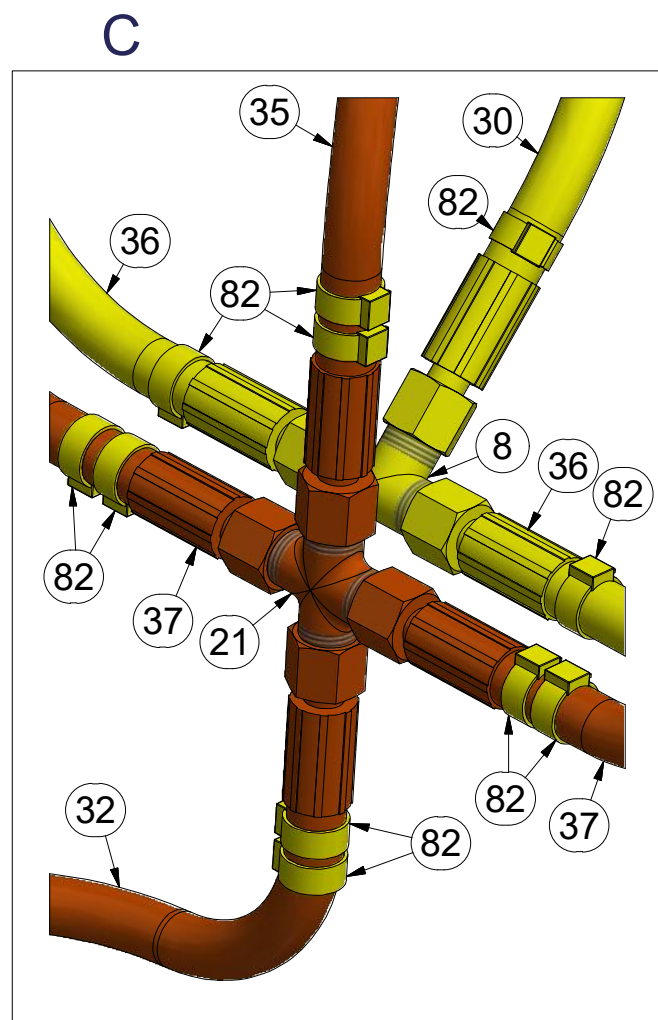
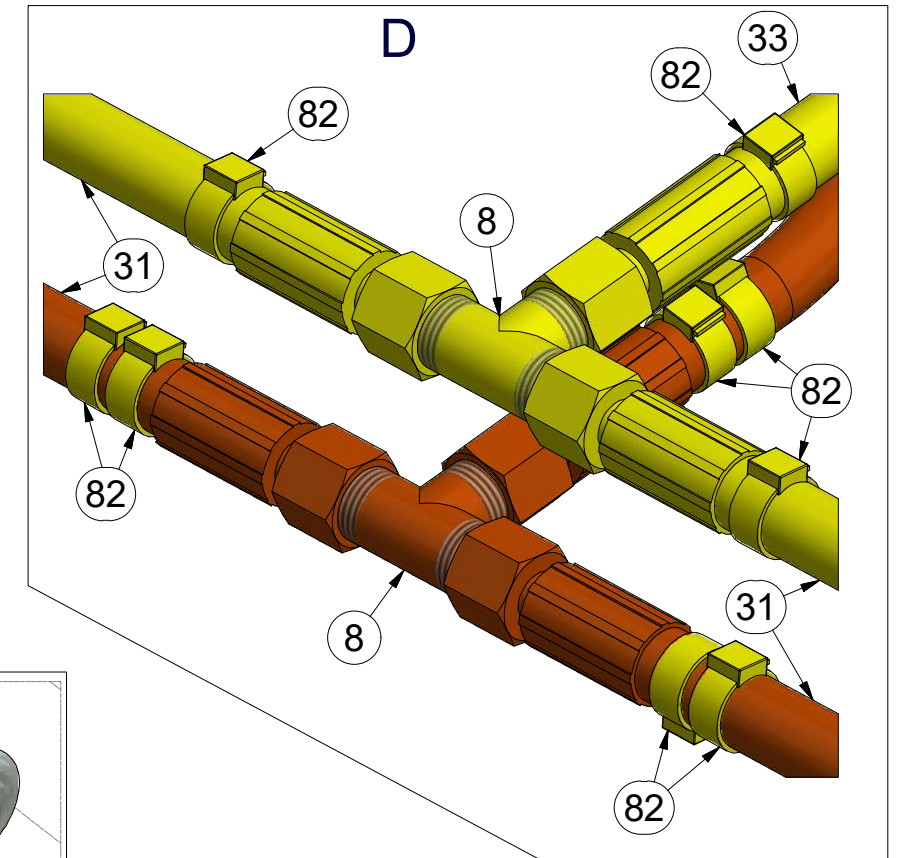
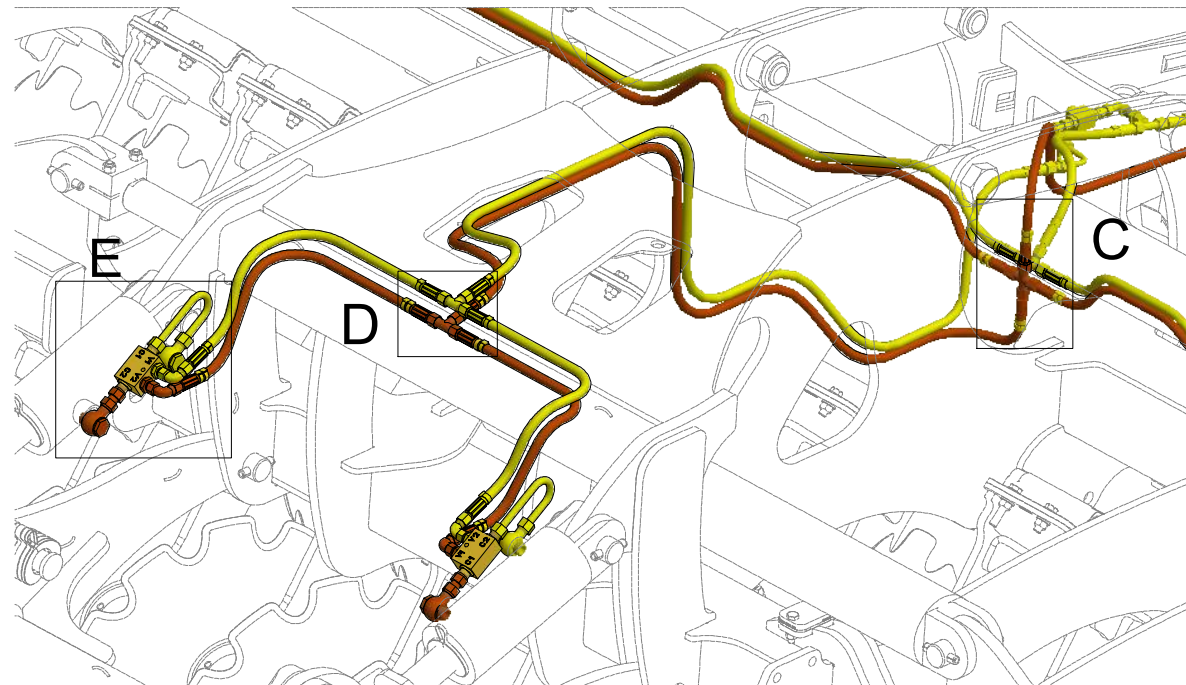

Pos.	Part Number	Pcs.	Pos.	Part Number	Pcs.
1	m08083	2	18	m05212	2
2	m04623	1	19	m03213	1
3	m03849	2	20	m04023	2
4	m08391	2	21	m08328	1
5	m09658	2	34	m09036	1
7	m10493	1	35	m05216	1
8	m03889	3	30	m04761	1
9	m07906	4	33	m04181	1
10	m06803	8	32	m09037	1
11	m05144	2	37	m09431	2
12	m08861	4	36	m04752	2
13	m06528	4	31	m07645	4
14	m08862	4	82	m11289	38
15	m08860	4			
16	m02609	4			
17	m04223	8			

Ⓒ HYDRAULICKÝ ROZVOD SKLÁPĚNÍ

Ⓓ HYDRAULISCHE VERTEILUNG KLAPPMCHANISMUS

Ⓕ CONDUIT HYDRAULIQUE DU BASCULEMENT

Ⓖ HYDRAULIC FOLDING DISTRIBUTION

Ⓡ ГИДРАВЛИЧЕСКОЕ РАСПРЕДЕЛЕНИЕ СКЛАДЫВАНИЯ

Ⓢ HYDRAULICZNY PRZEWÓD SKŁADANIA



3004951

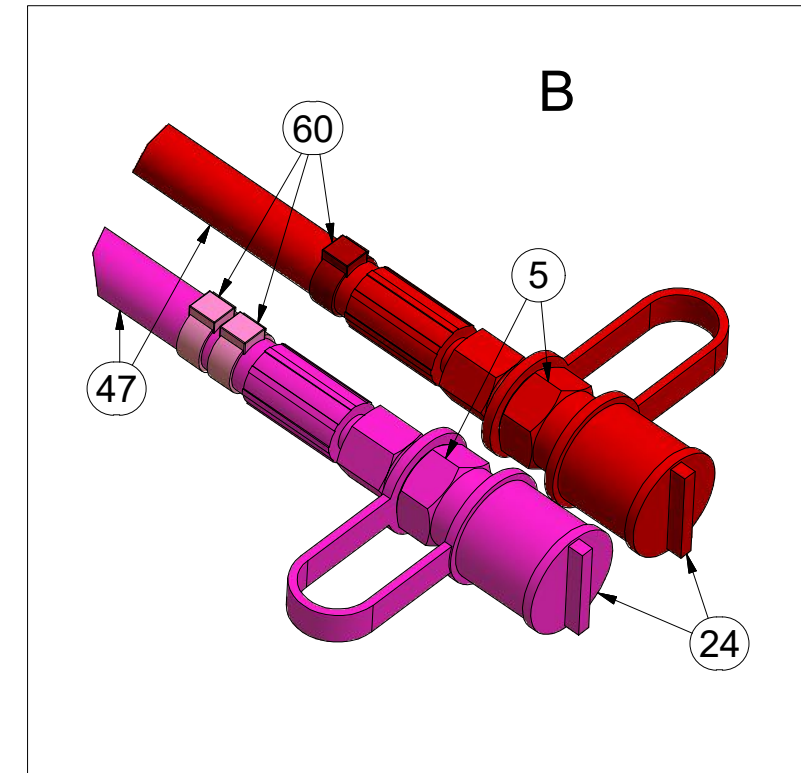
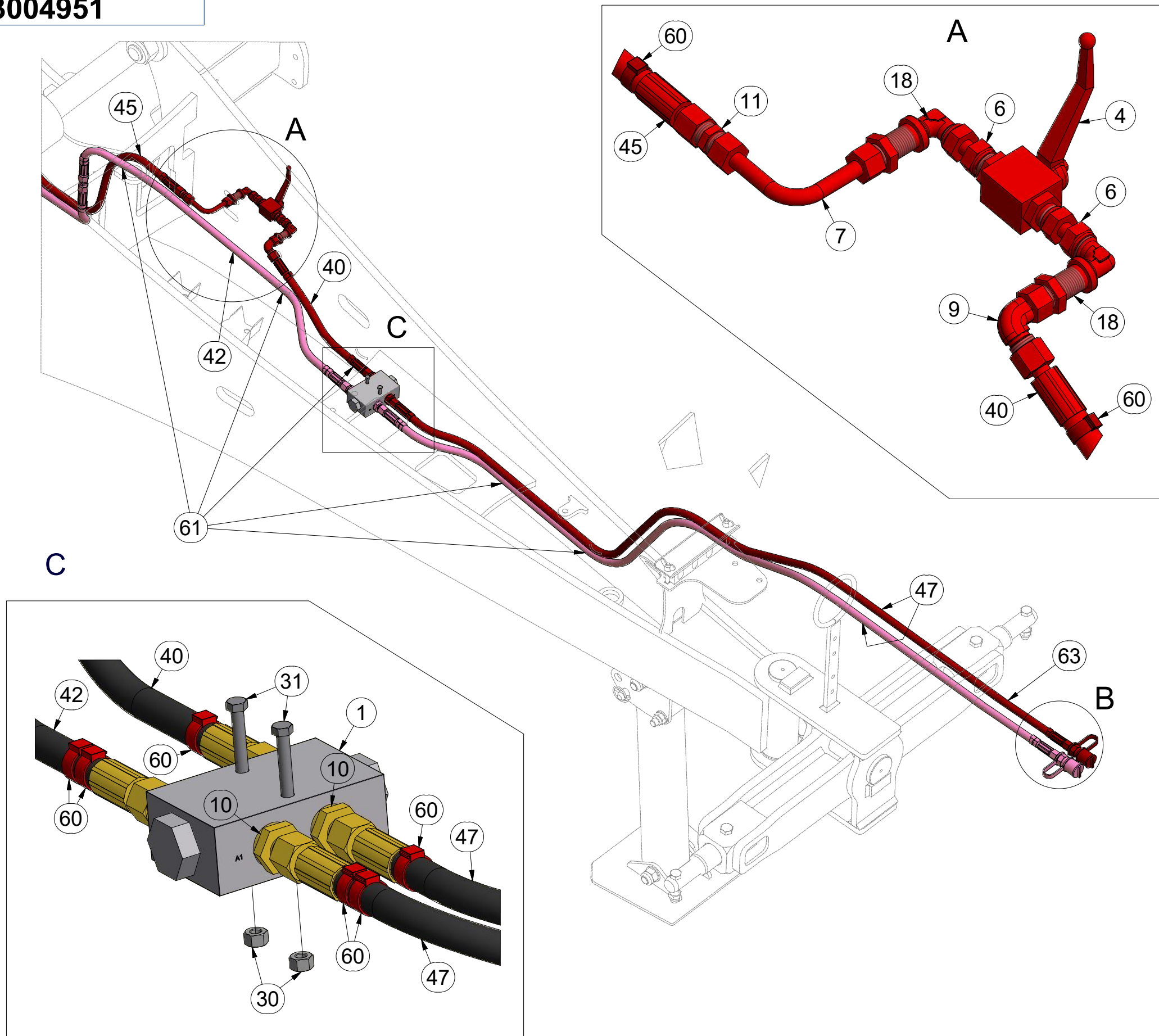

Pos.	Part Number	Pcs.
1	m09911	1
4	m04623	1
5	m03849	2
6	m05212	2
7	m10493	1
9	m06803	7
10	m06528	4
11	m03213	2
18	m08391	2
24	m04022	2
30	m05560	2
31	m04843	2
40	m09627	1
42	m04033	1
45	m05210	2
47	m08000	2
60	m11294	34
61	m05566	20
62	m05573	10
63	m11183	1

Ⓒ HYDRAULICKÝ ROZVOD SKLÁPĚNÍ

Ⓓ HYDRAULISCHE VERTEILUNG KLAPPMECHANISMUS

Ⓕ CONDUIT HYDRAULIQUE DU BASCULEMENT

Ⓖ HYDRAULIC FOLDING DISTRIBUTION

Ⓡ ГИДРАВЛИЧЕСКОЕ РАСПРЕДЕЛЕНИЕ СКЛАДЫВАНИЯ

Ⓟ HYDRAULICZNY PRZEWÓD SKŁADANIA



3004951

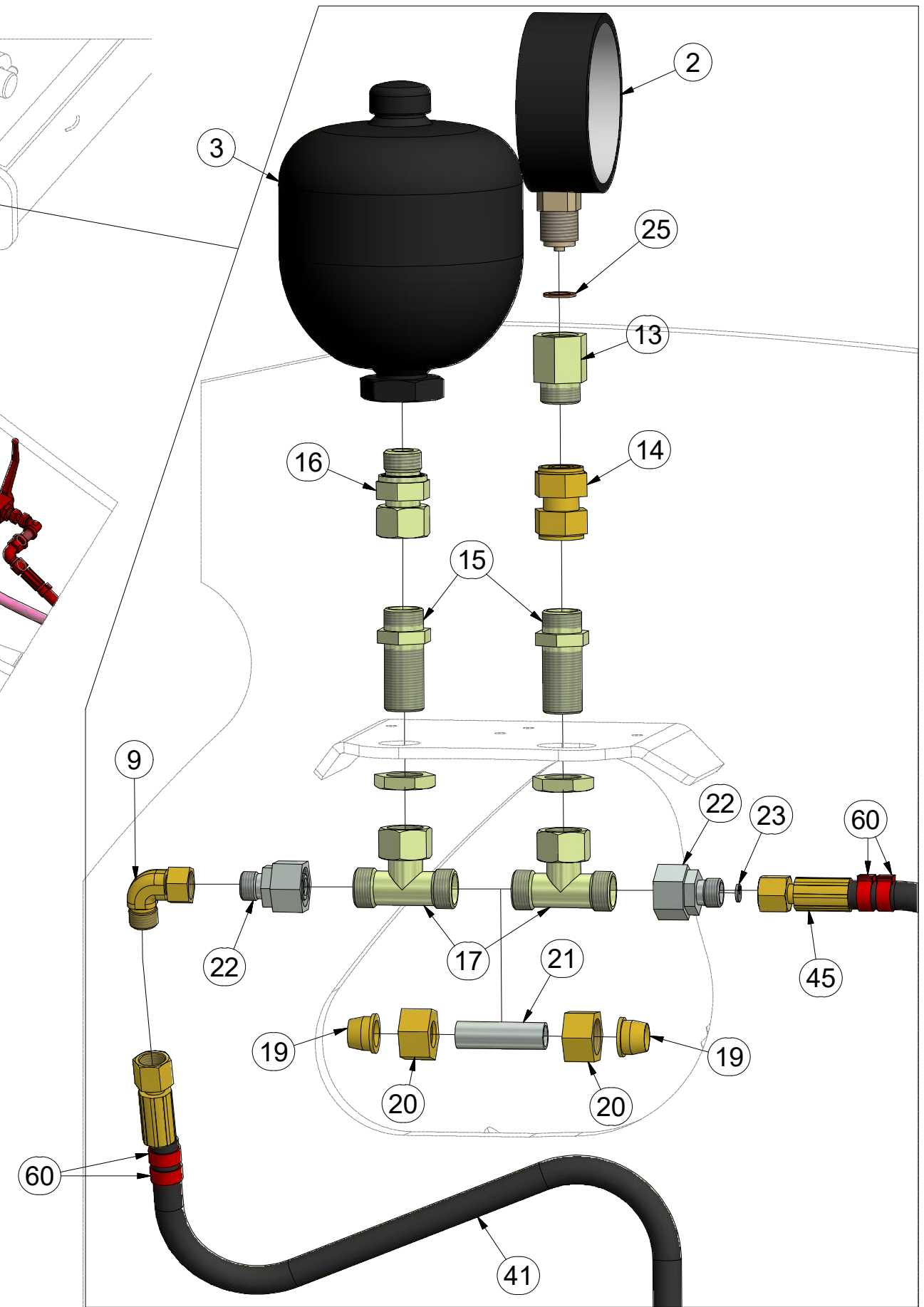
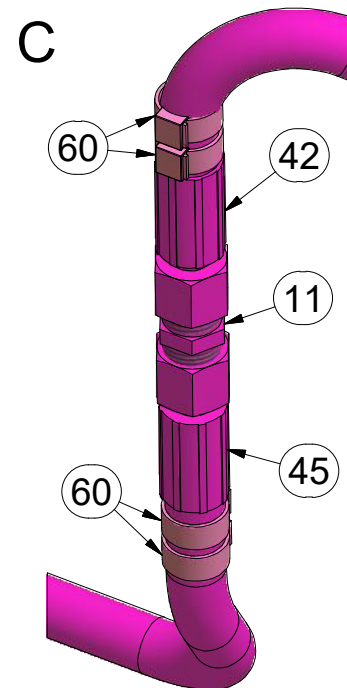
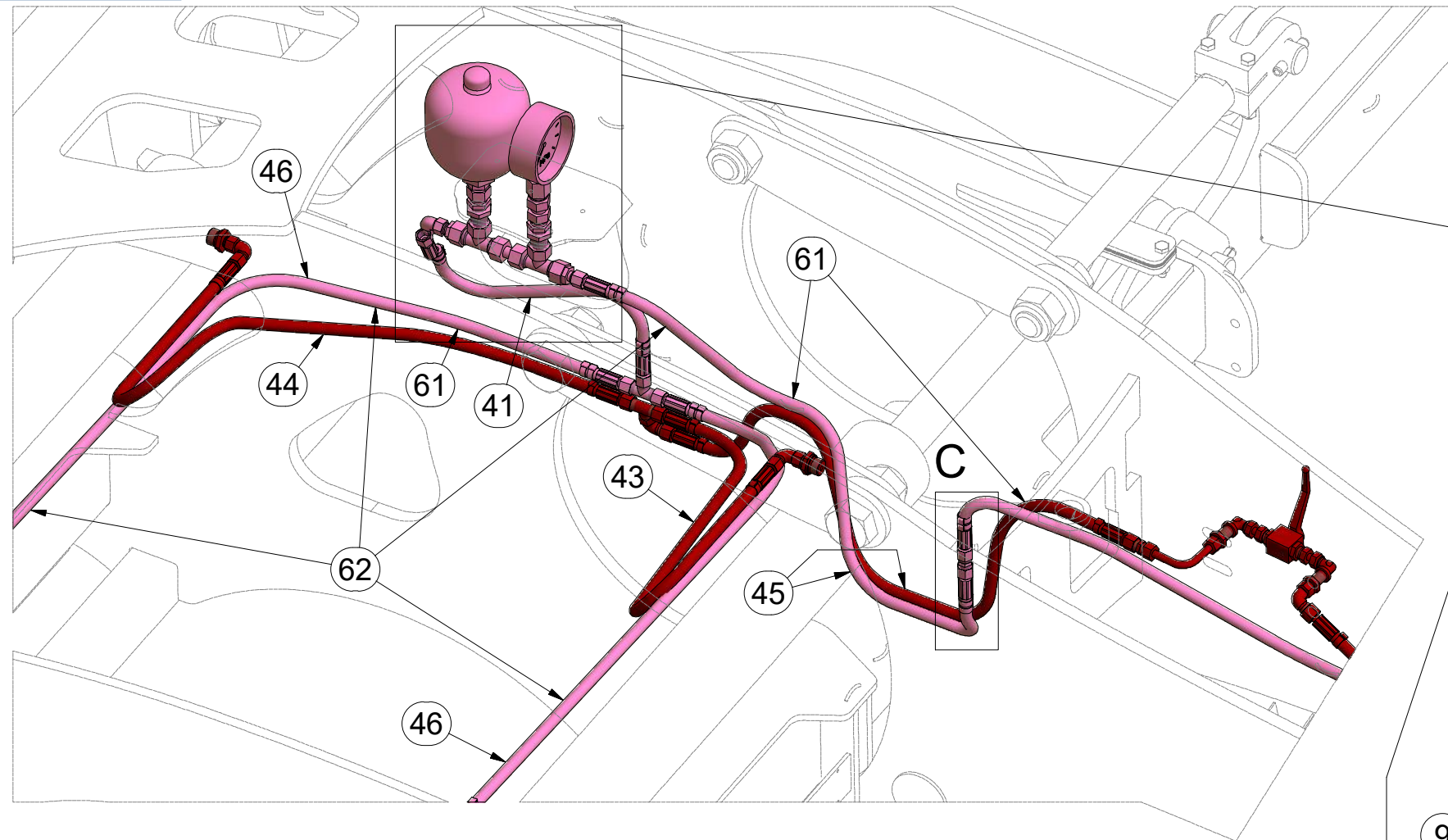

Pos.	Part Number	Pcs.	Pos.	Part Number	Pcs.
2	m05518	1	21	m11782	1
3	m09910	1	22	m08533	2
9	m06803	7	23	m10773	3
11	m03213	2	25	m04320	1
13	m11974	1	41	m04827	1
14	m06135	1	42	m04033	1
15	m09625	2	43	m07364	1
16	m07993	1	44	m03951	1
17	m06879	2	45	m05210	2
19	m11781	2	46	m07360	2
20	m09926	2	60	m11294	34
			62	m05573	10

ⒸZ HYDRAULICKÝ ROZVOD SKLÁPĚNÍ

Ⓓ HYDRAULISCHE VERTEILUNG KLAPPMCHANISMUS

Ⓕ CONDUIT HYDRAULIQUE DU BASCULEMENT

ⒼB HYDRAULIC FOLDING DISTRIBUTION

Ⓔ RU ГИДРАВЛИЧЕСКОЕ РАСПРЕДЕЛЕНИЕ СКЛАДЫВАНИЯ

Ⓗ PL HYDRAULICZNY PRZEWÓD SKŁADANIA



3004951

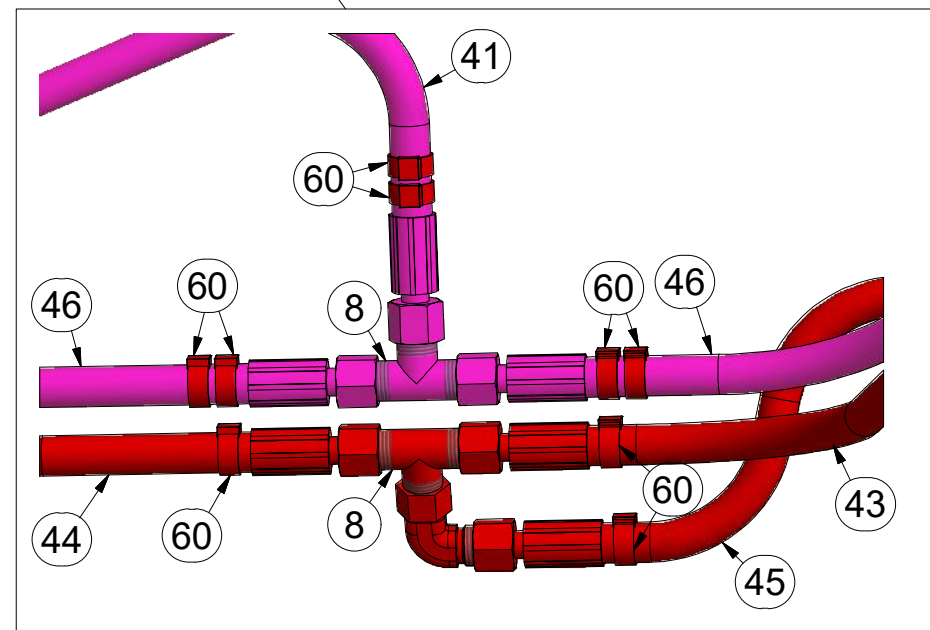
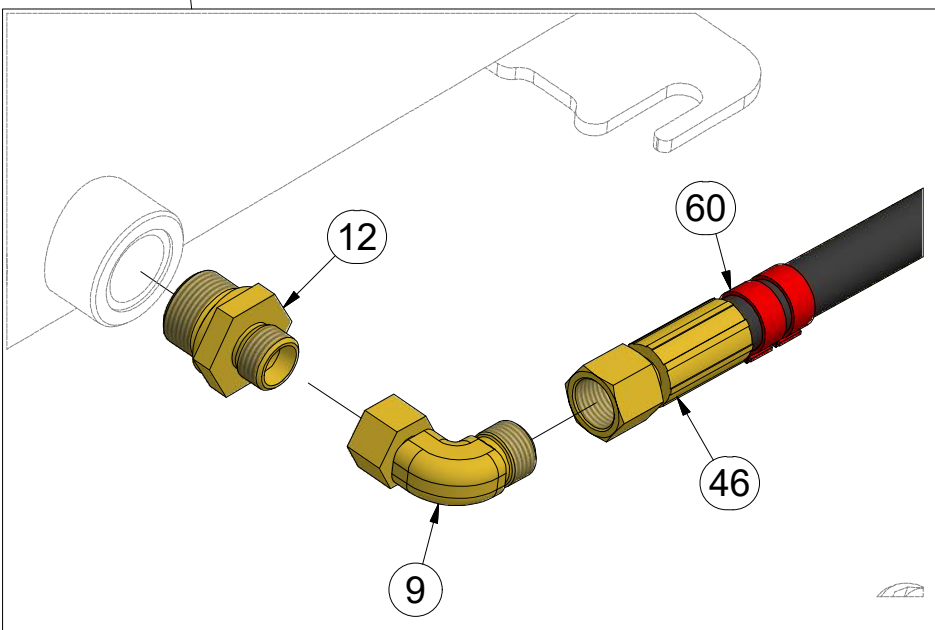
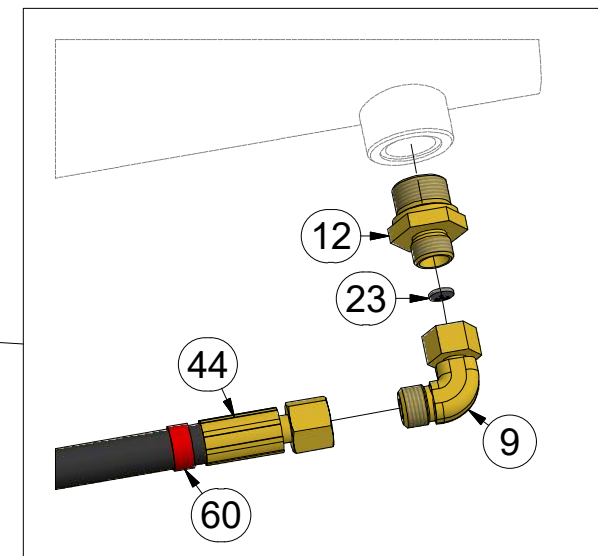
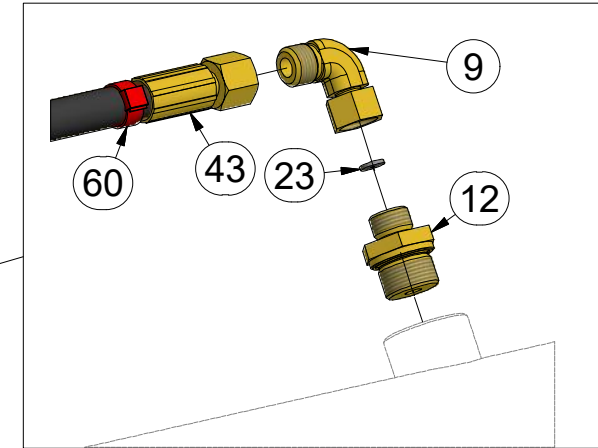
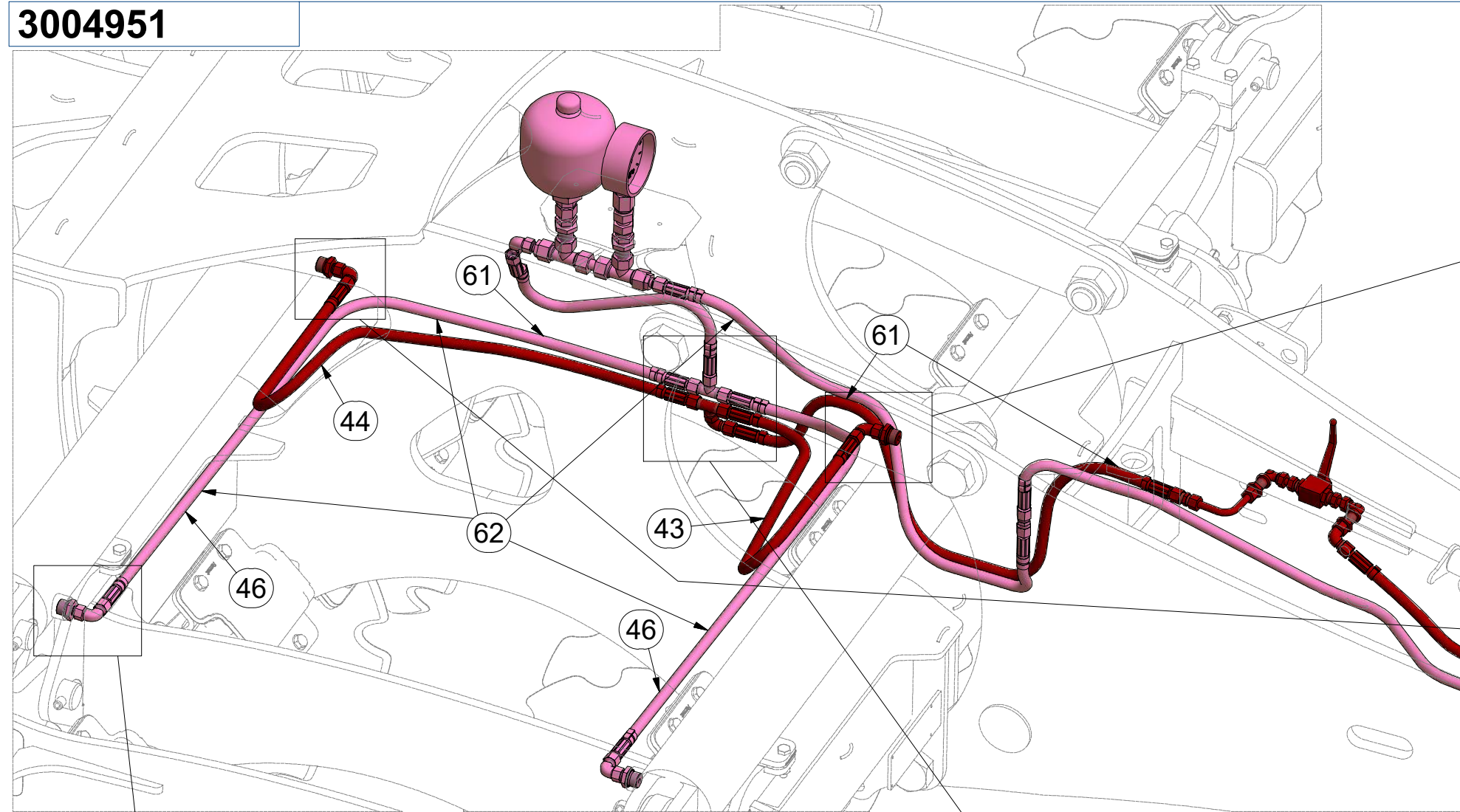

Pos.	Part Number	Pcs.
8	m03889	2
9	m06803	7
12	m09934	4
41	m04827	1
43	m07364	1
44	m03951	1
45	m05210	2
46	m07360	2
60	m11294	34
61	m05566	20
62	m05573	10

Ⓒ PÍSTNICE 63/40-95

Ⓓ KOLBENSTANGE 63/40-95

Ⓕ TIGE DE PISTON 63/40-95

Ⓖ PISTON ROD 63/40-95

Ⓡ ЦИЛИНДР 63/40-95

Ⓟ TRZPIEŃ TŁOKA 63/40-95



4015781

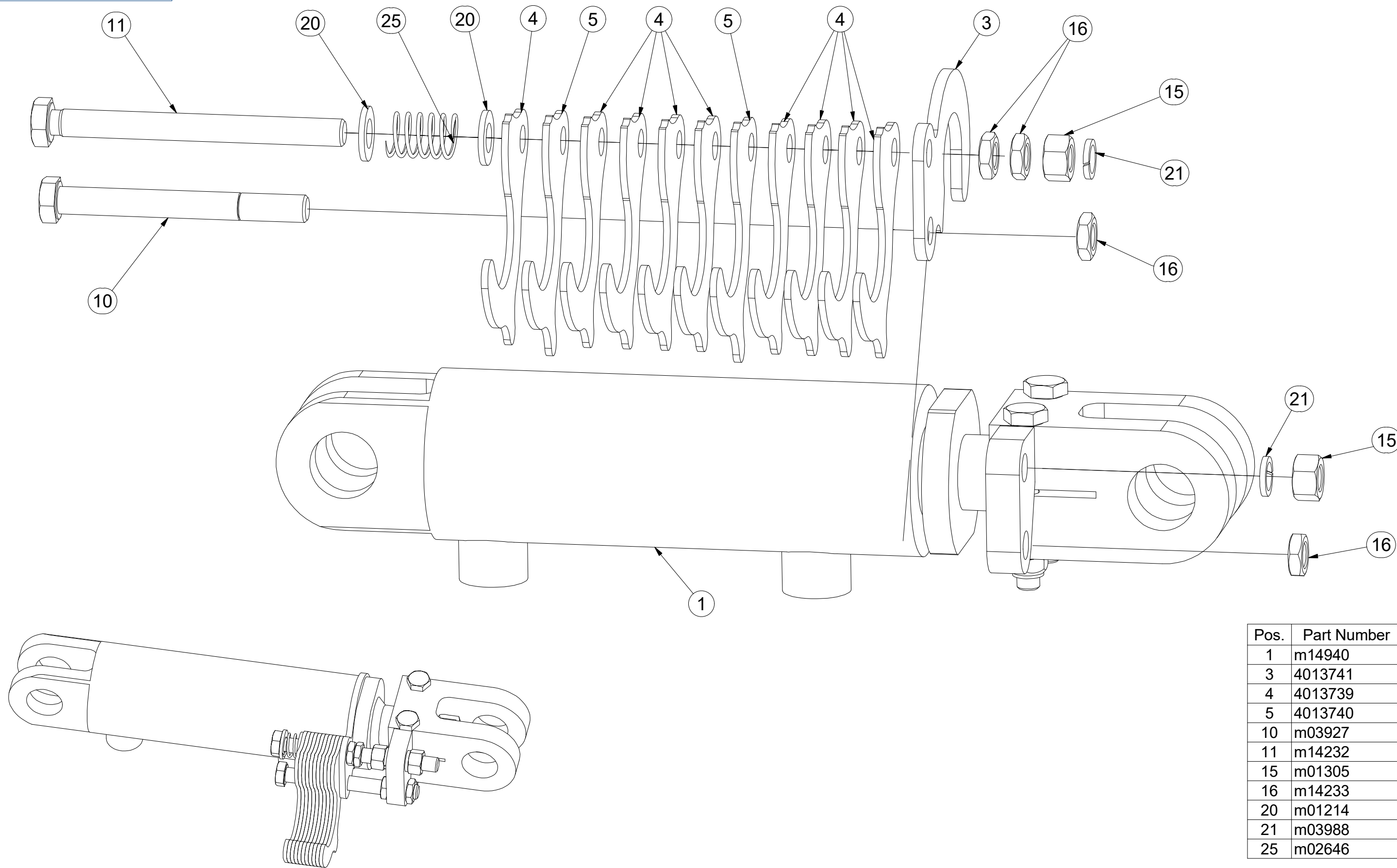

Pos.	Part Number	Pcs.
1	m14940	1
3	4013741	1
4	4013739	9
5	4013740	2
10	m03927	1
11	m14232	1
15	m01305	2
16	m14233	4
20	m01214	2
21	m03988	2
25	m02646	1

Ⓒ PÍSTNICE 100/50-100

Ⓓ KOLBENSTANGE 100/50-100

Ⓕ TIGE DE PISTON 100/50-100

Ⓖ PISTON ROD 100/50-100

Ⓡ ЦИЛИНДР 100/50-100

Ⓟ TRZPIEŃ TŁOKA 100/50-100



4015787

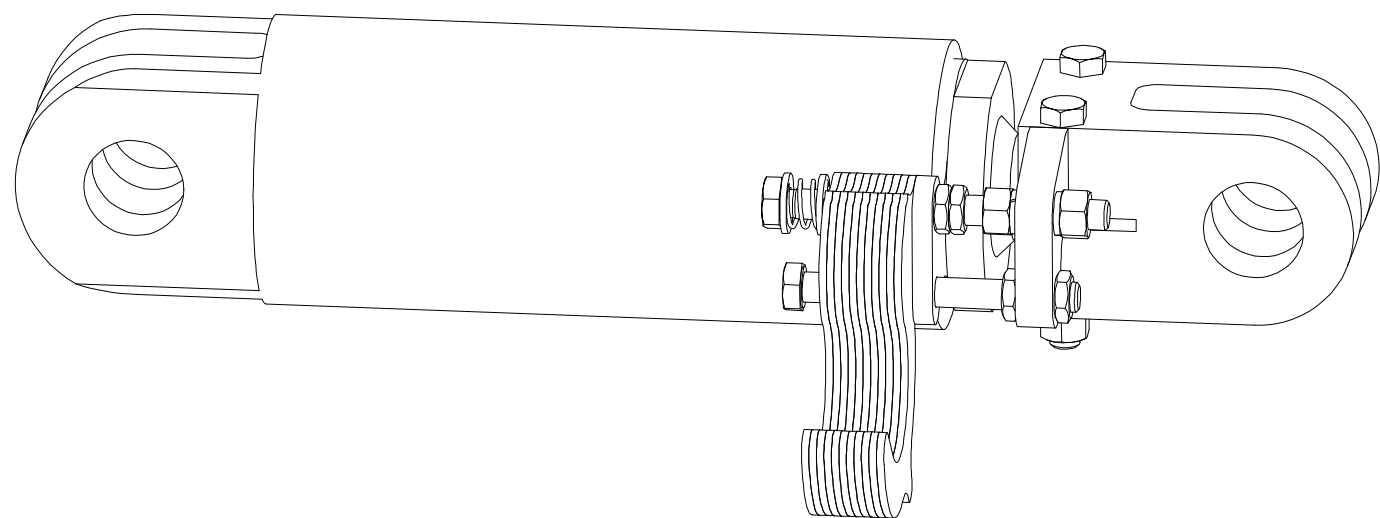
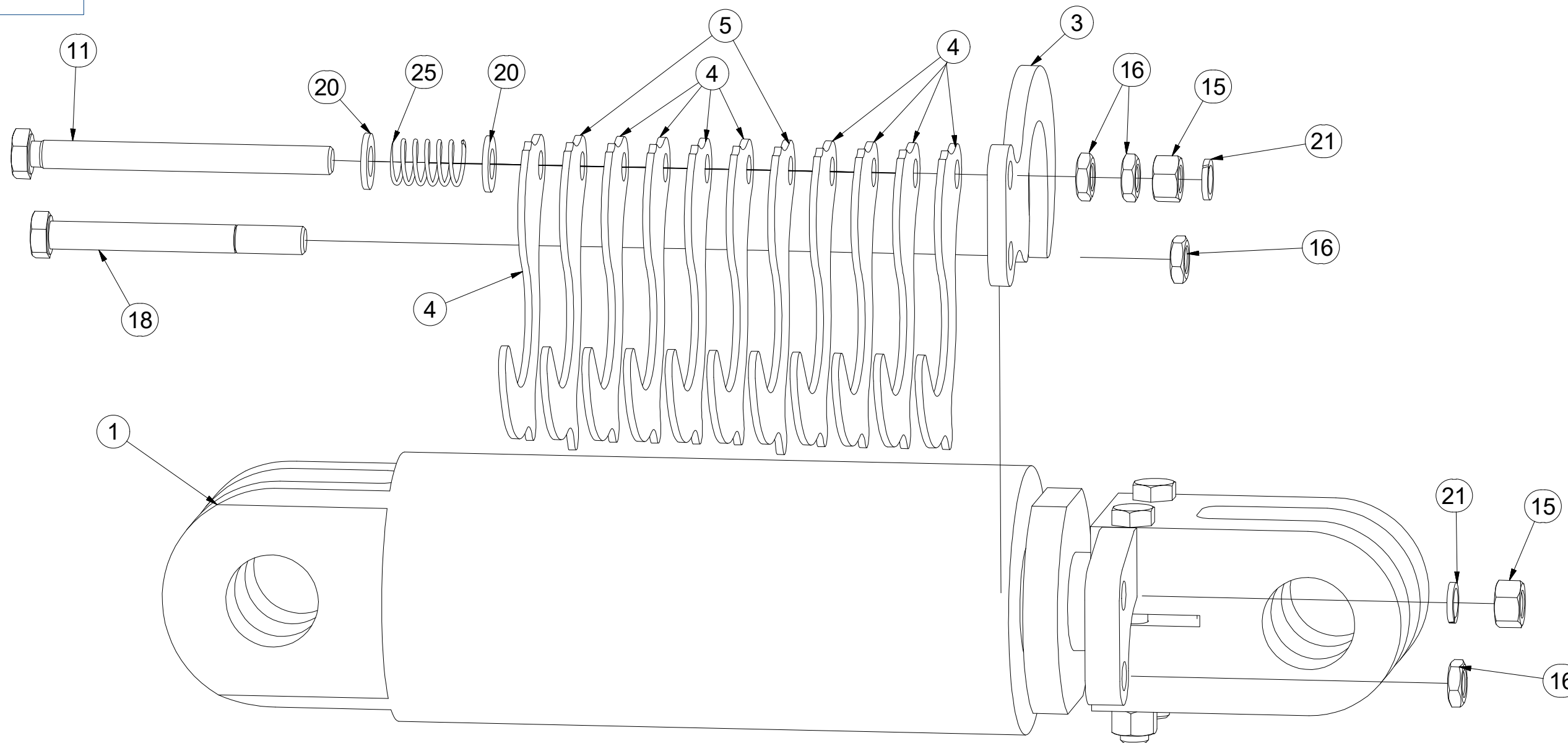

Pos.	Part Number	Pcs.
1	m14941	1
3	4014342	1
4	4014331	9
5	4014334	2
11	m14232	1
15	m01305	2
16	m14233	4
18	m03927	1
20	m01214	2
21	m03988	2
25	m02646	1

Ⓒ SOUPRAVA TĚSNIVA PÍSTNIC

Ⓓ KOLBENSTANGENDICHTUNGSMITTELSATZ

Ⓕ SET DE GARNITURE DES TIGES DE PISTON

Ⓖ SEALING SET FOR PISTON RODS

Ⓡ КОМПЛЕКТ ПРОКЛАДОК ЦИЛИНДРОВ

Ⓟ ZESTAW USZCZELEK TRZPIENIA TŁOKA

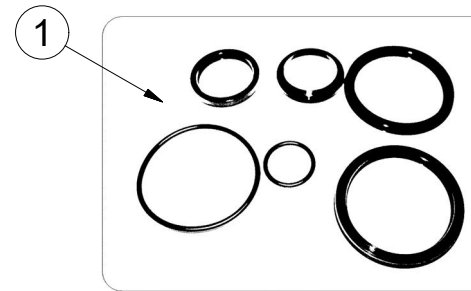
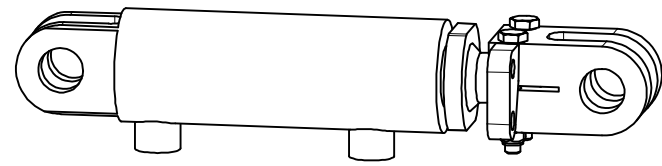

m14940 - Ø63/Ø40-95		
Pos	Part number	Pcs
1	m15372	2

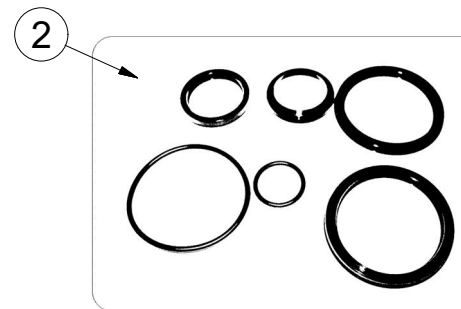
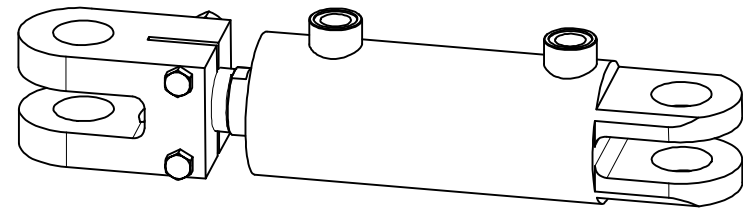

m14956 - Ø80/Ø45-100		
Pos	Part number	Pcs
2	m15373	2

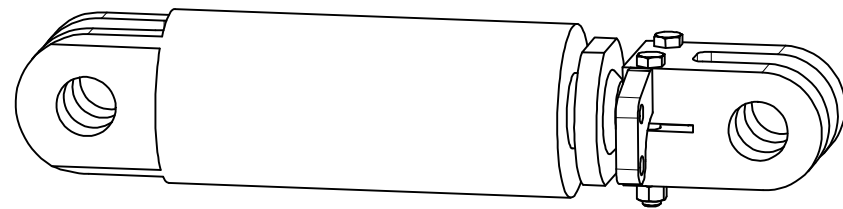

m14941 - Ø100/Ø50-100		
Pos	Part number	Pcs
3	m15375	2

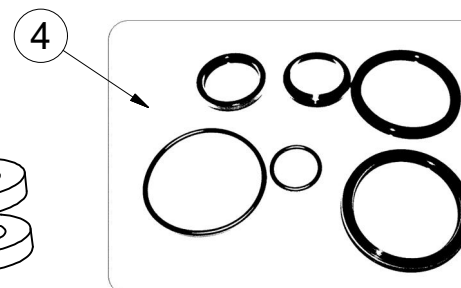
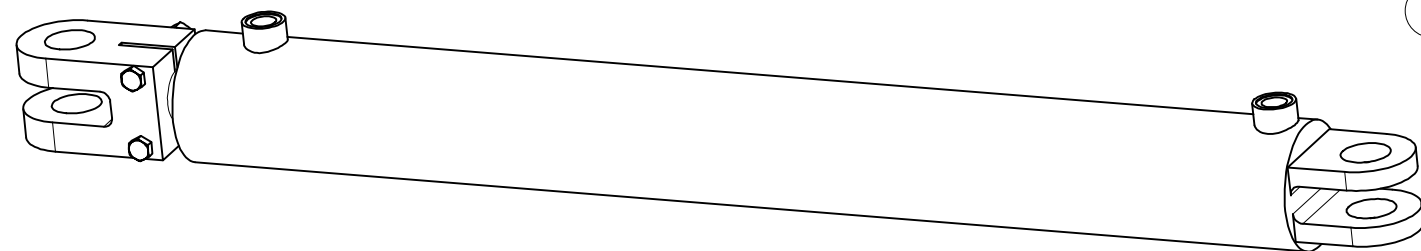

m14955 - Ø90/Ø45-830		
Pos	Part number	Pcs
4	m15374	2

Ⓒ SVĚTELNÁ SADA

Ⓓ LEUCHTENSATZ

Ⓕ KIT LUMINEUX

Ⓖ LIGHTING SET

Ⓡ ОСВЕТИТЕЛЬНЫЙ КОМПЛЕКТ

Ⓟ ZESTAW OŚWIETLENIA



3008454

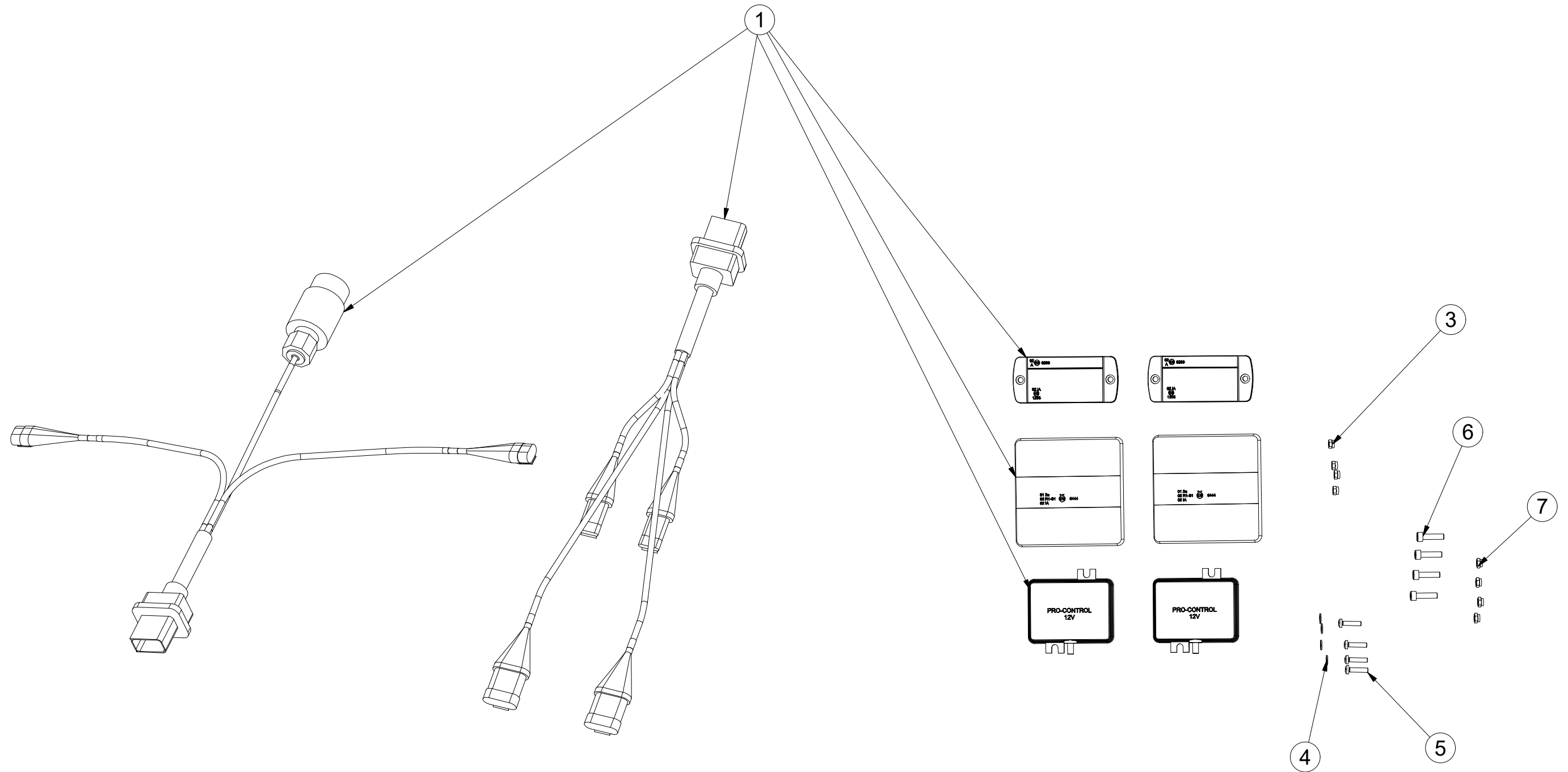

Pos.	Part Number	Pcs.
1	m15240	1
3	m05562	4
4	m05597	4
5	m15790	4
6	m10591	4
7	m06236	4
30	m05566	50

Ⓒ SVĚTELNÁ SADA

Ⓓ LEUCHTENSATZ

Ⓕ KIT LUMINEUX

m15240

Ⓖ LIGHTING SET

Ⓡ ОСВЕТИТЕЛЬНЫЙ КОМПЛЕКТ

Ⓟ ZESTAW OŚWIETLENIA

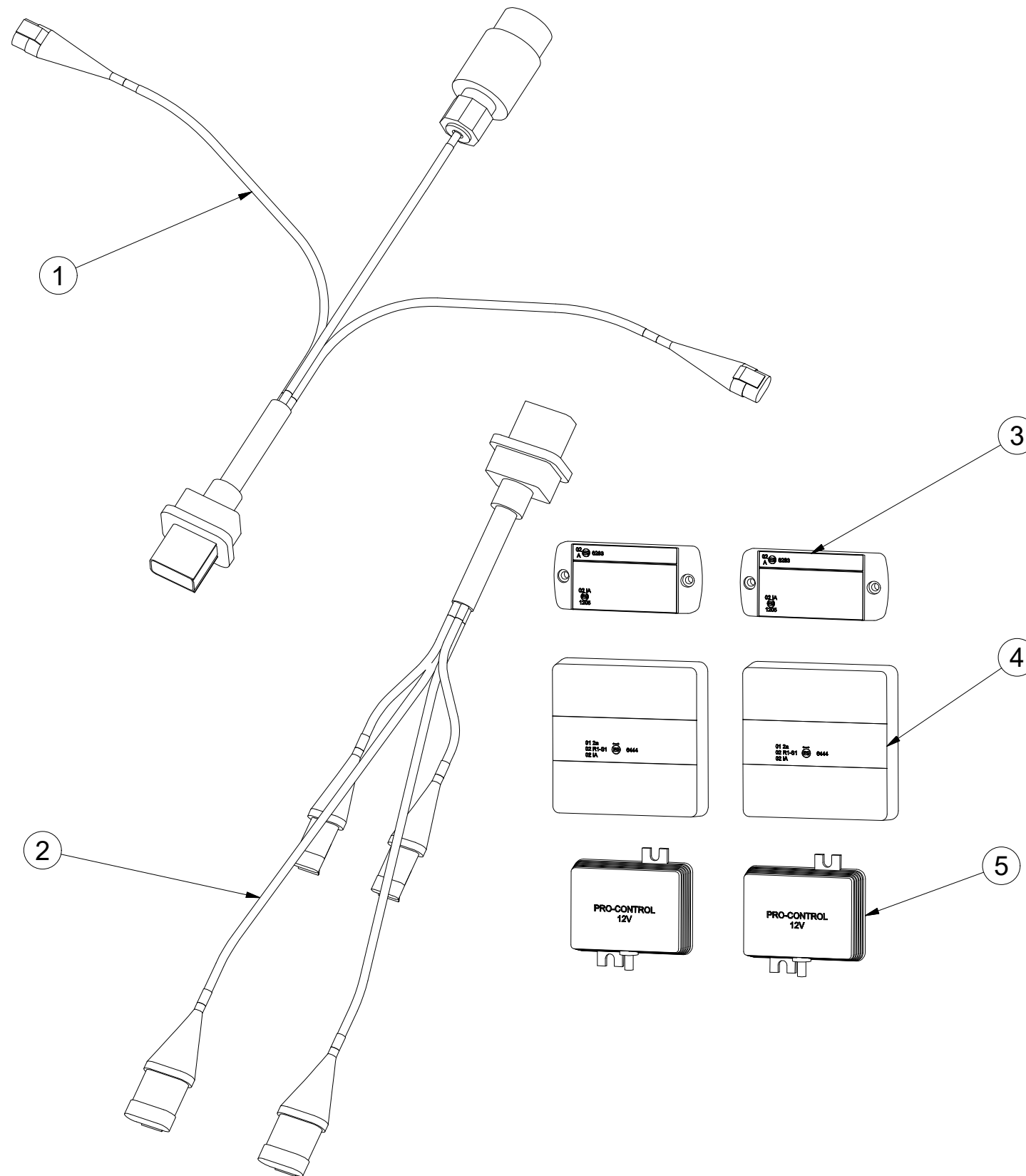

Pos.	Part Number	Pcs.
1	m14779	1
2	m14778	1
3	m14776	2
4	m14865	2
5	m14777	2

☉ SAMOLEPKY STROJE

☐ AUFKLEBER MASCHINEN

☉ VOITURE MACHINES

8000789-30018

☉ STICKERS MACHINES

☉ СТИКЕРЫ МАШИНЫ

☉ NAKLEJKI MASZYNY

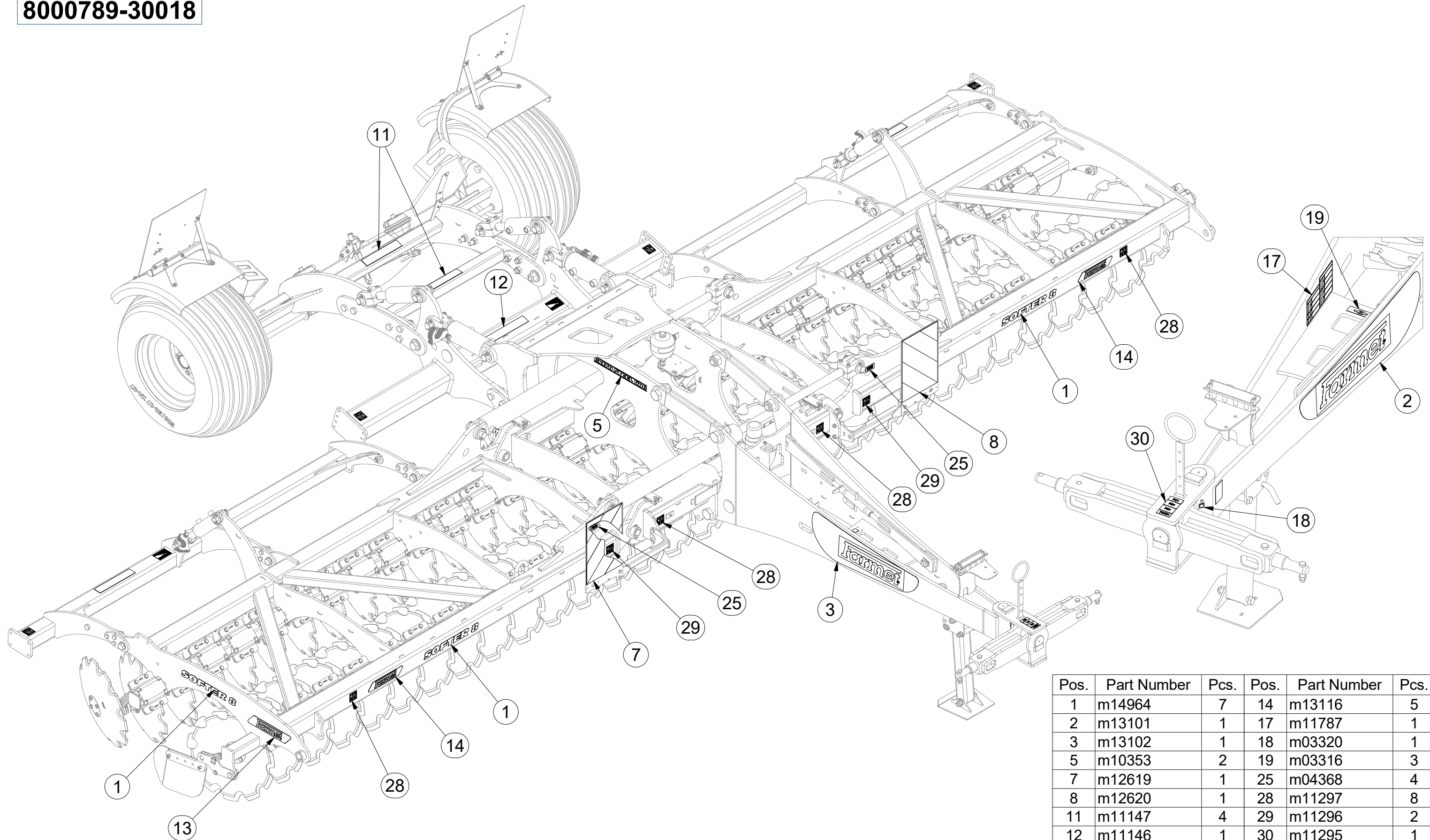

Pos.	Part Number	Pcs.	Pos.	Part Number	Pcs.
1	m14964	7	14	m13116	5
2	m13101	1	17	m11787	1
3	m13102	1	18	m03320	1
5	m10353	2	19	m03316	3
7	m12619	1	25	m04368	4
8	m12620	1	28	m11297	8
11	m11147	4	29	m11296	2
12	m11146	1	30	m11295	1
13	m13117	2			

☉ SAMOLEPKY STROJE

☉ AUFKLEBER MASCHINEN

☉ VOITURE MACHINES

☉ STICKERS MACHINES

☉ СТИКЕРЫ МАШИНЫ

☉ NAKLEJKI MASZYNY



8000789-30018

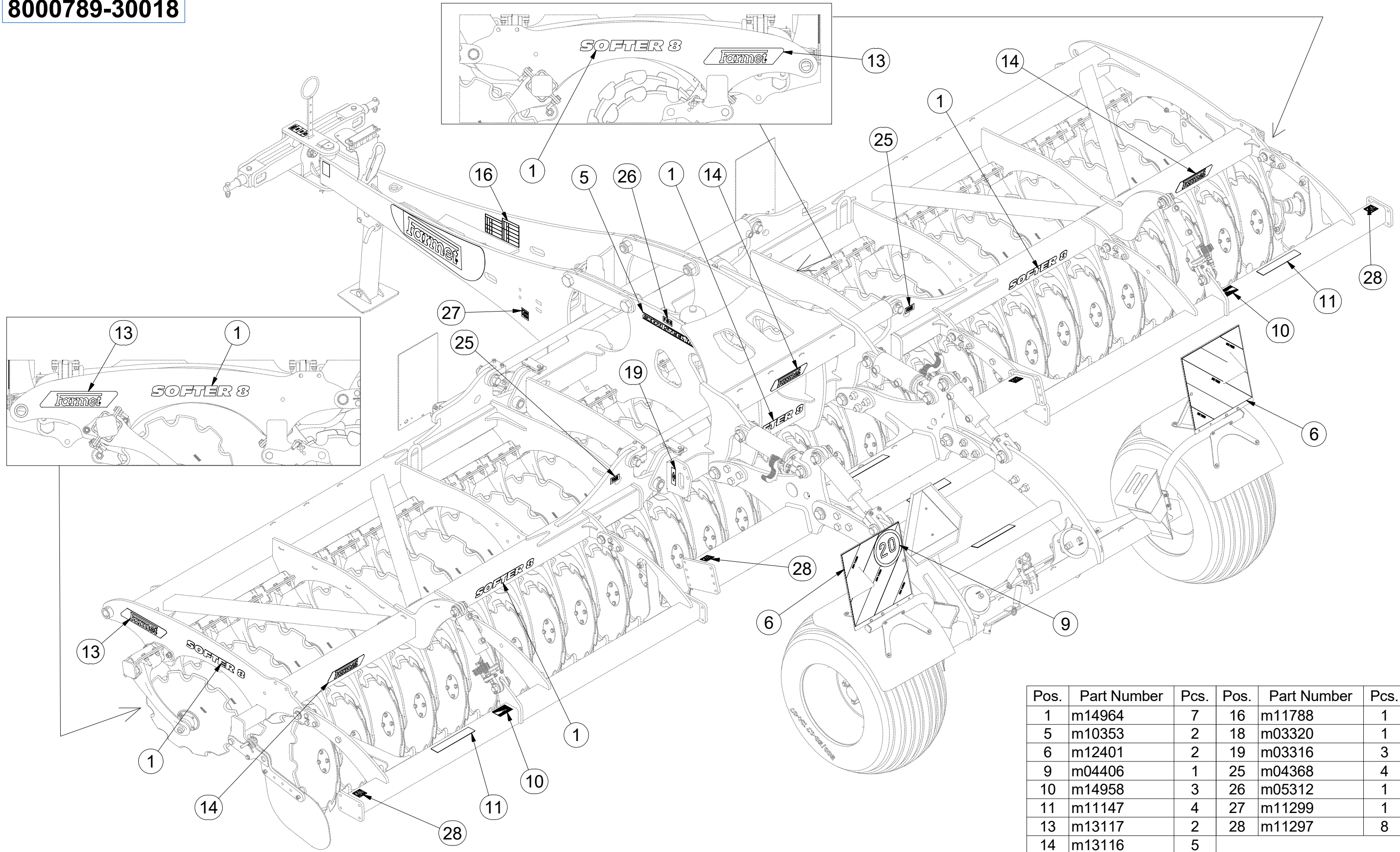

Pos.	Part Number	Pcs.	Pos.	Part Number	Pcs.
1	m14964	7	16	m11788	1
5	m10353	2	18	m03320	1
6	m12401	2	19	m03316	3
9	m04406	1	25	m04368	4
10	m14958	3	26	m05312	1
11	m11147	4	27	m11299	1
13	m13117	2	28	m11297	8
14	m13116	5			