

*The effective technology*

# Farmet®

ⒸZ KATALOG NÁHRADNÍCH DÍLŮ ⒸB CATALOGUE OF SPARE PARTS ⒸD ERSATZTEILLISTE  
ⒸRU КАТАЛОГ ЗАПАСНЫХ ЧАСТЕЙ ⒸF CATALOGUE DES PIÈCES DE RECHANGE ⒸPL KATALOG CZĘŚCI ZAMIENNYCH

## SOFTER 6 PS

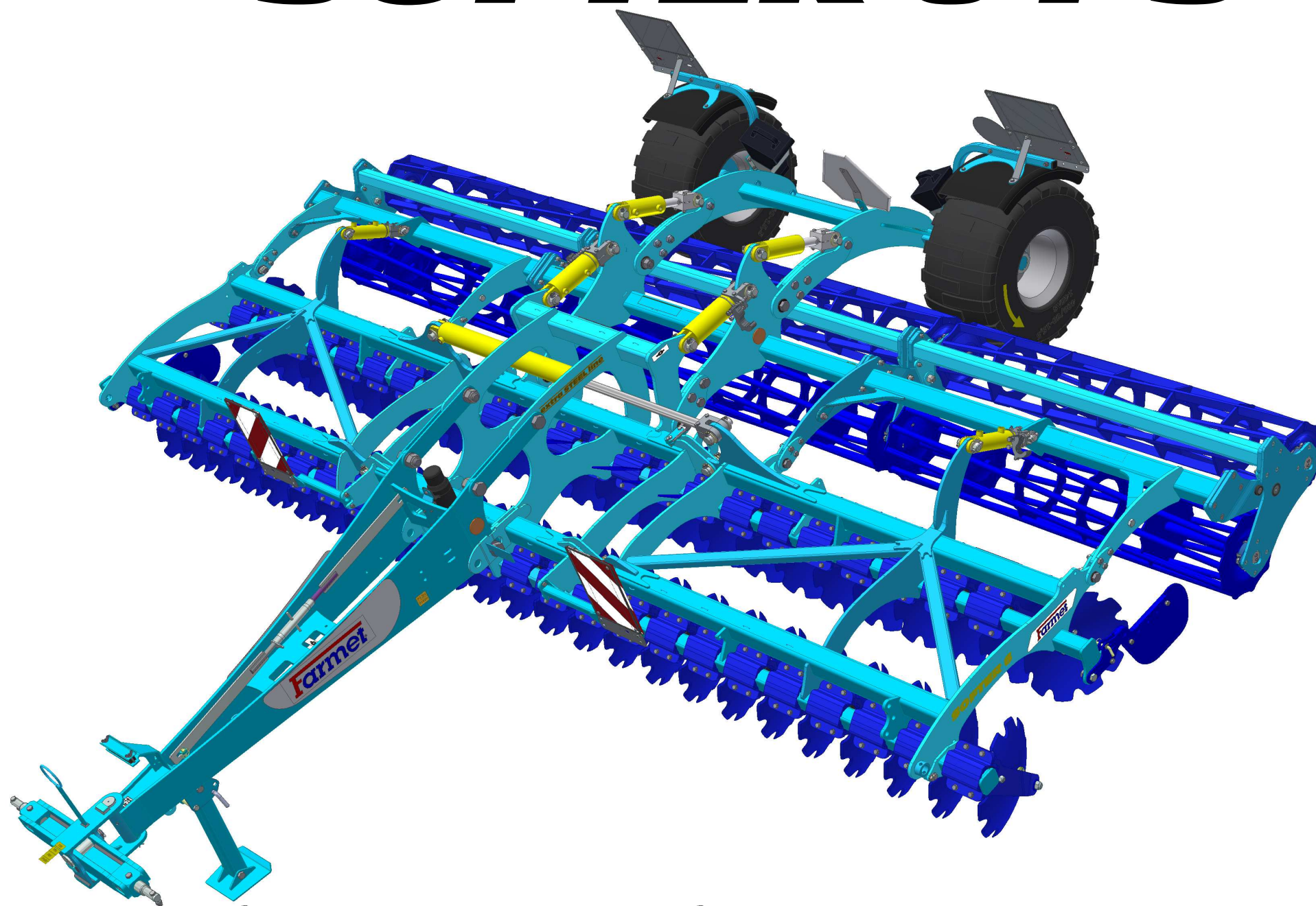

ⒸZ Platnost pro vrcholové | výrobní číslo stroje ⒸB Validity for the top | serial number of the machine  
ⒸD Gültigkeit für die Haupt- | Herstellungsnummer der Maschine ⒸRU Действительно для главного | заводского номера машины  
ⒸF Validité du numéro de référence | de série de la machine ⒸPL Obowiązuje dla numeru głównego | seryjnego maszyny

9316295 | 2017/0620

Farmet a. s.  
Jiřinková 276  
552 03 Česká Skalice, CZ

telefon: +420 491 450 111  
fax: +420 491 450 136  
GSM: +420 774 715 738

IČ: 46504931  
DIČ: CZ46504931

web: [www.farmet.cz](http://www.farmet.cz)  
e-mail: [farmet@farmet.cz](mailto:farmet@farmet.cz)

ⒸZ NAVIGACE STROJE

Ⓓ NAVIGATION DER MASCHINE

Ⓕ NAVIGATION DE LA MACHINE

ⒸB NAVIGATION OF THE MACHINE

ⒸU НАВИГАЦИЯ МАШИНЫ

ⒸL NAWIGACJA MASZYN

**Farmet**

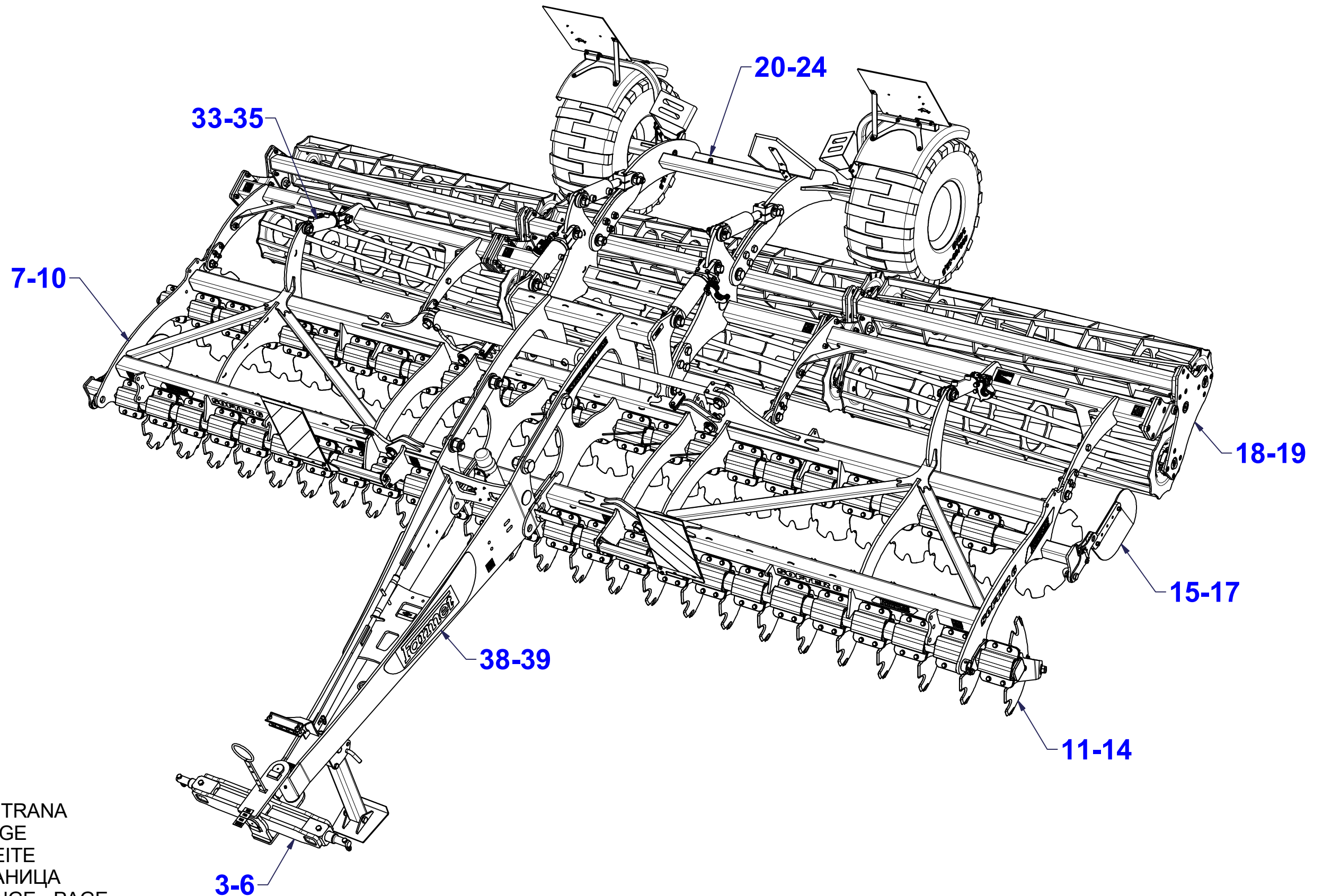

ⒸZ NÁHRADNÍ DÍL - STRANA

ⒸB SPARE PART - PAGE

Ⓓ ERSATZTEILE - SEITE

ⒸU ЗАПЧАСТЬ - СТРАНИЦА

Ⓕ PIÈCE DE RECHANGE - PAGE

ⒸL CZĘŚCI ZAMIENNE - STRONA

Ⓒ CZ OJ T3

Ⓓ DEICHSEL T3

Ⓕ TIMON T3

**3007316**

Ⓖ GB TOW BAR T3

Ⓡ RU ДЫШЛО T3

Ⓟ PL DYSZEL T3

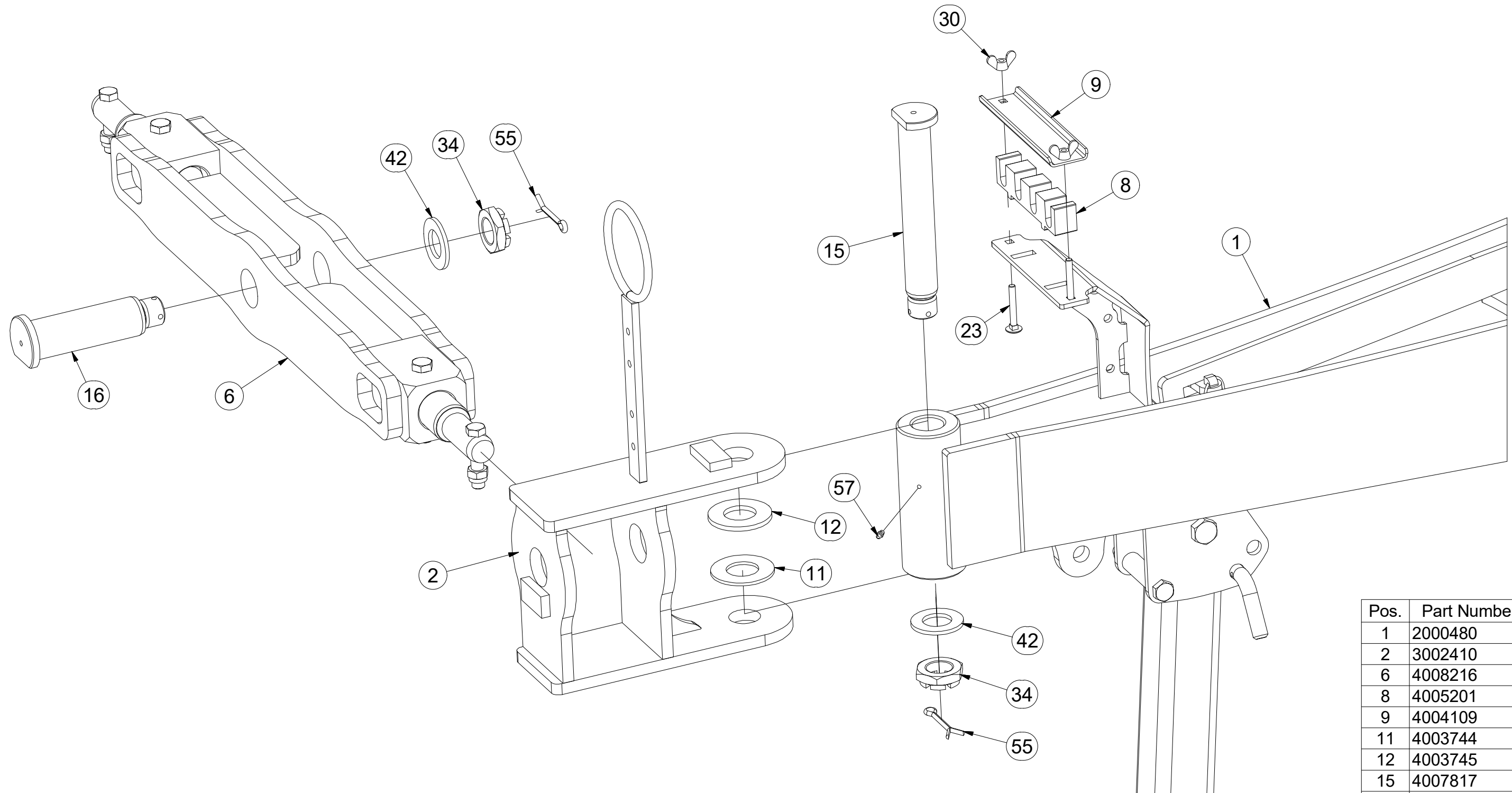

Pos.	Part Number	Pcs.
1	2000480	1
2	3002410	1
6	4008216	1
8	4005201	1
9	4004109	1
11	4003744	1
12	4003745	1
15	4007817	1
16	4007818	1
23	m09247	2
30	m01316	2
34	m02533	2
42	m03866	2
55	m04139	2
57	m01725	1

Ⓒ CZ OJ T3

Ⓓ DEICHSEL T3

Ⓕ TIMON T3

**3007316**

Ⓖ GB TOW BAR T3

Ⓡ RU ДЫШЛО T3

Ⓟ PL DYSZEL T3

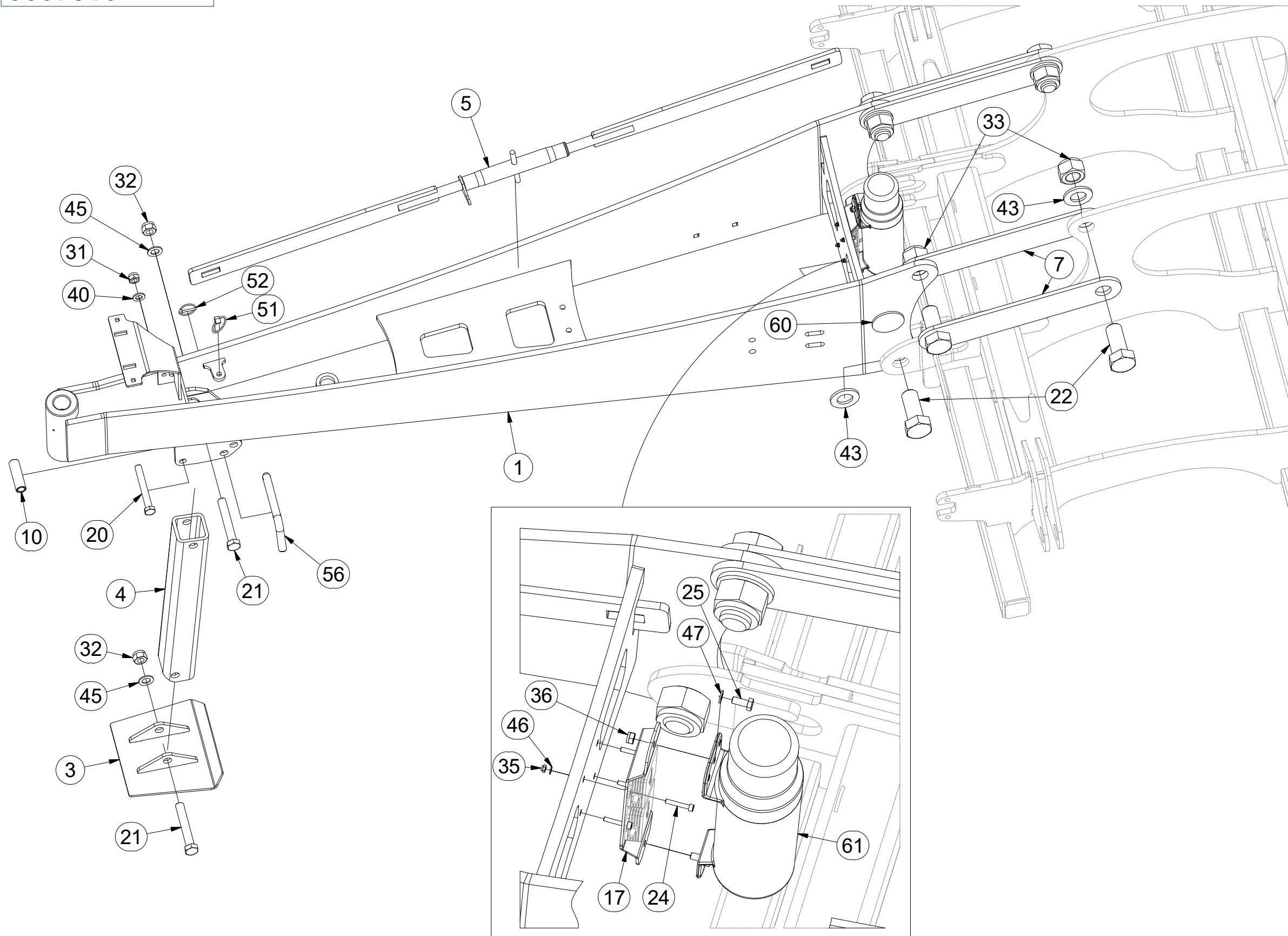

Pos.	Part Number	Pcs.
1	2000480	1
3	4007000	1
4	4006699	1
5	4009414	1
7	4007828	4
10	4004007	1
17	4017879	1
20	m04404	1
21	m05465	2
22	m12179	6
24	m10029	4
25	m01089	2
31	m03683	1
32	m05648	2
33	m11337	6
35	m06236	4
36	m04503	2
40	m01219	1
43	m03175	6
45	m03768	2
46	m04164	4
47	m01203	2
51	m02505	1
52	m10454	1
56	m08386	1
60	m02579	2
61	m15900	1

Ⓒ ZÁVĚSNÁ TYČ T3

Ⓓ KÖNIGSSTANGE T3

Ⓕ TIGE DE SUSPENSION T3

**4008216**

Ⓖ DRAWBAR T3

Ⓡ ПОДВЕШАЯ ШТАНГА Т3

Ⓟ PRĘT ZAWIESZANY T3

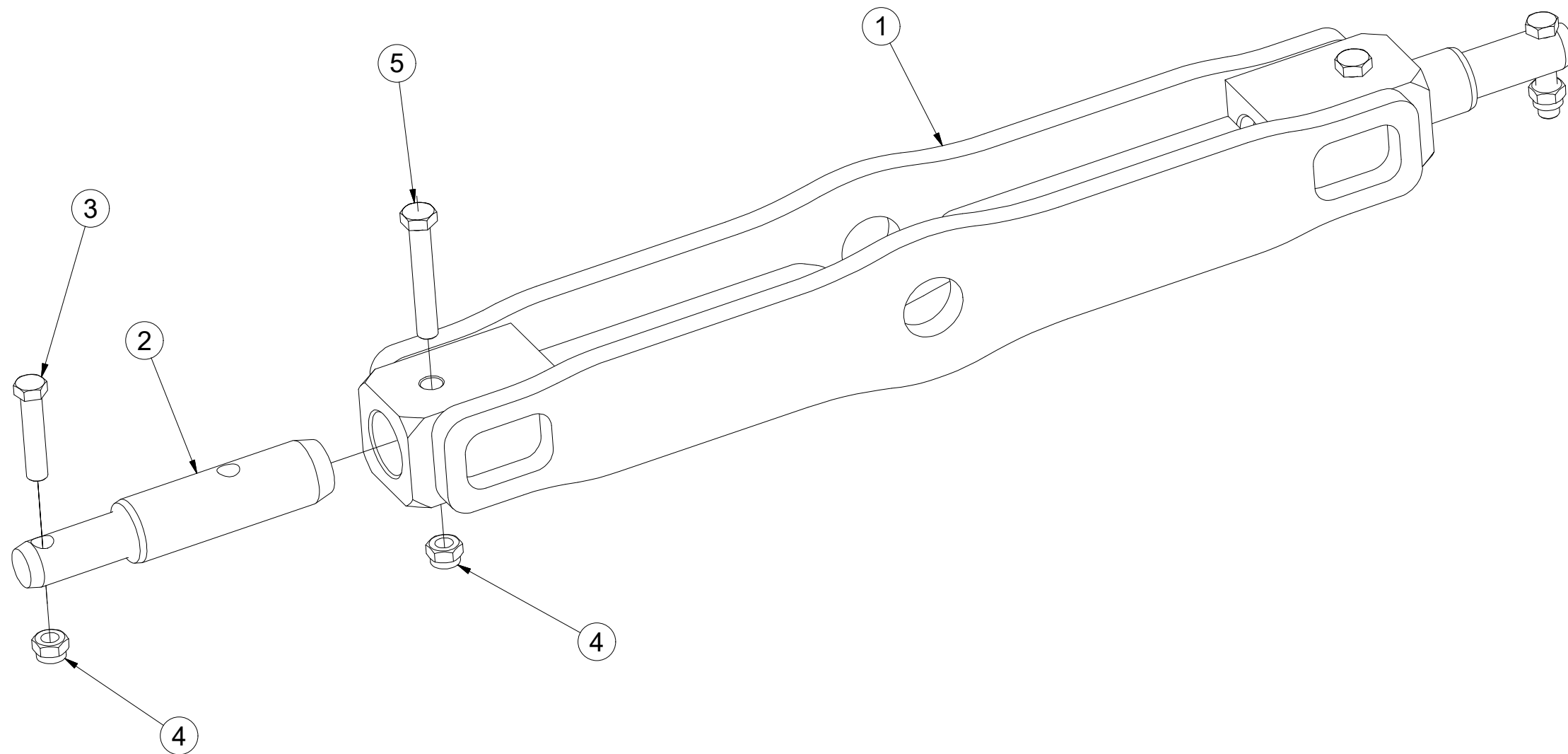

Pos.	Part Number	Pcs.
1	3004315	1
2	4008217	2
3	m01133	2
4	m03683	4
5	m05304	2

Ⓒ SPOJOVACÍ TÁHLO  
Ⓓ VERBINDUNGSSTANGE  
Ⓕ TIGE DE RACCORDEMENT

Ⓖ CONNECTING ROD  
Ⓡ СОЕДИНИТЕЛЬНАЯ ТЯГА  
Ⓟ KORBOWÓD



**4009414**

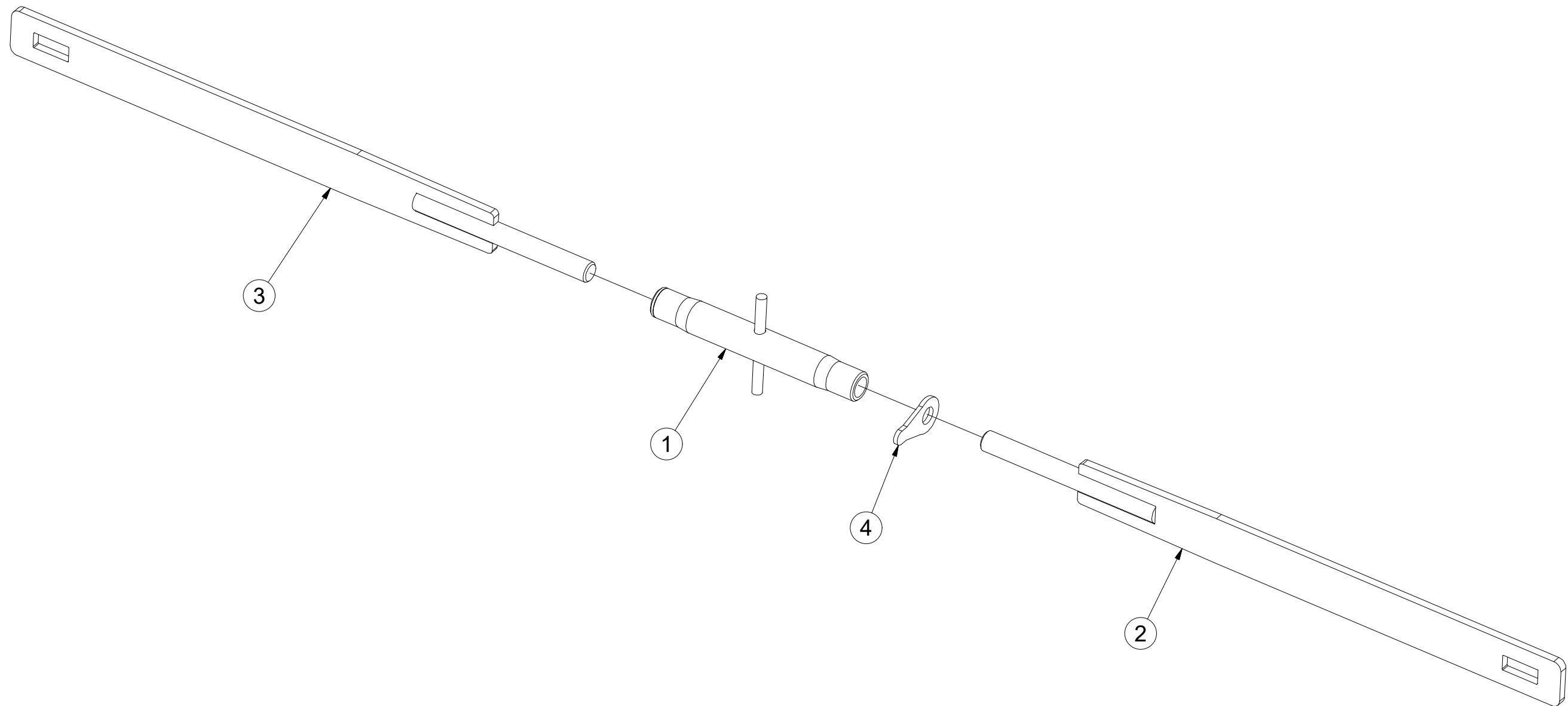

Pos.	Part Number	Pcs.
1	m08880	1
2	4009415	1
3	4009417	1
4	m08881	1
5	m01999	1

☉ ZÁKLAD STROJE

☉ UNTERBAU DER MASCHINE

☉ BÂTI DE LA MACHINE

**3009675**

☉ FOOTING OF THE MACHINE

☉ ОСНОВАНИЕ МАШИНЫ

☉ PODSTAWA MASZINY

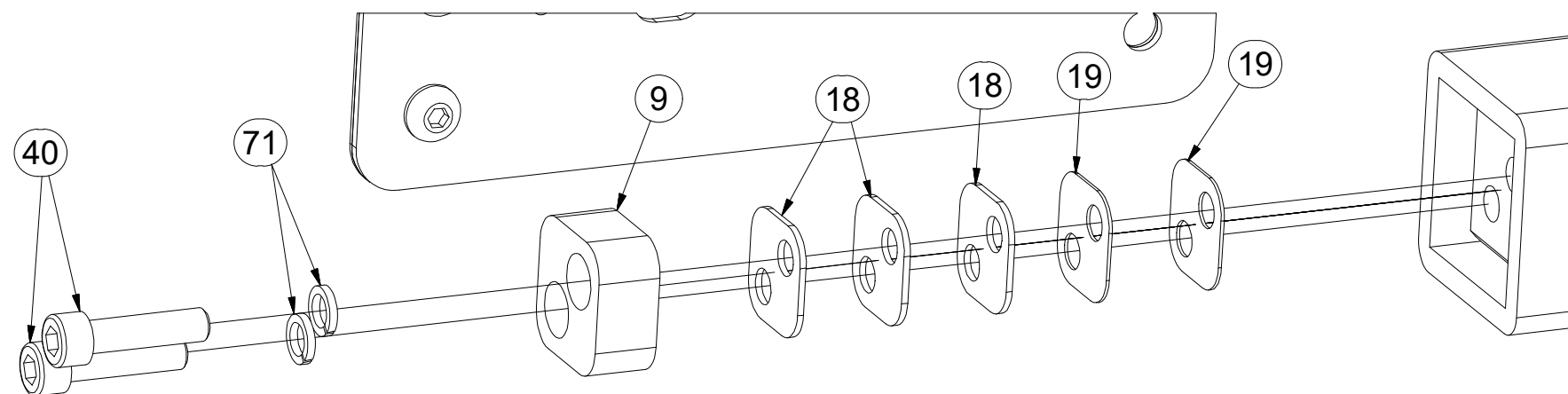
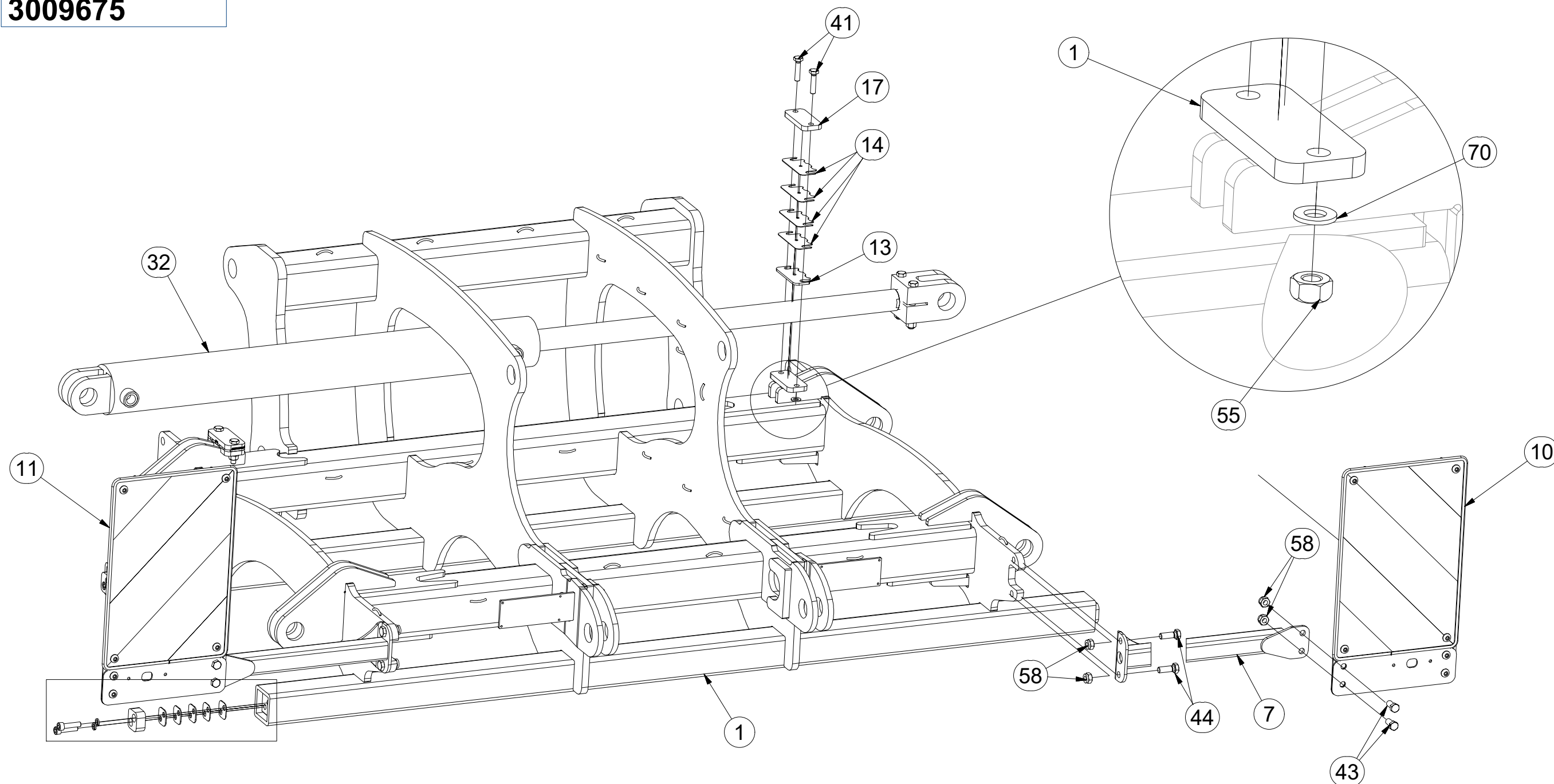

Pos.	Part Number	Pcs.	Pos.	Part Number	Pcs.
1	1000585	1	32	m14955	1
7	3005607	2	40	m14009	8
9	4017089	4	41	m10444	4
10	4019075	1	43	m08549	4
11	4019076	1	44	m04343	4
13	4010451	2	55	m08830	4
14	4009768	8	58	m06233	8
17	9003053	2	70	m01209	4
18	4017090	12	71	m01208	8
19	4017091	8			

Ⓒ ZÁKLAD STROJE

Ⓓ UNTERBAU DER MASCHINE

Ⓕ BÂTI DE LA MACHINE

Ⓖ FOOTING OF THE MACHINE

Ⓡ ОСНОВАНИЕ МАШИНЫ

Ⓢ PODSTAWA MASZYNY



3009675

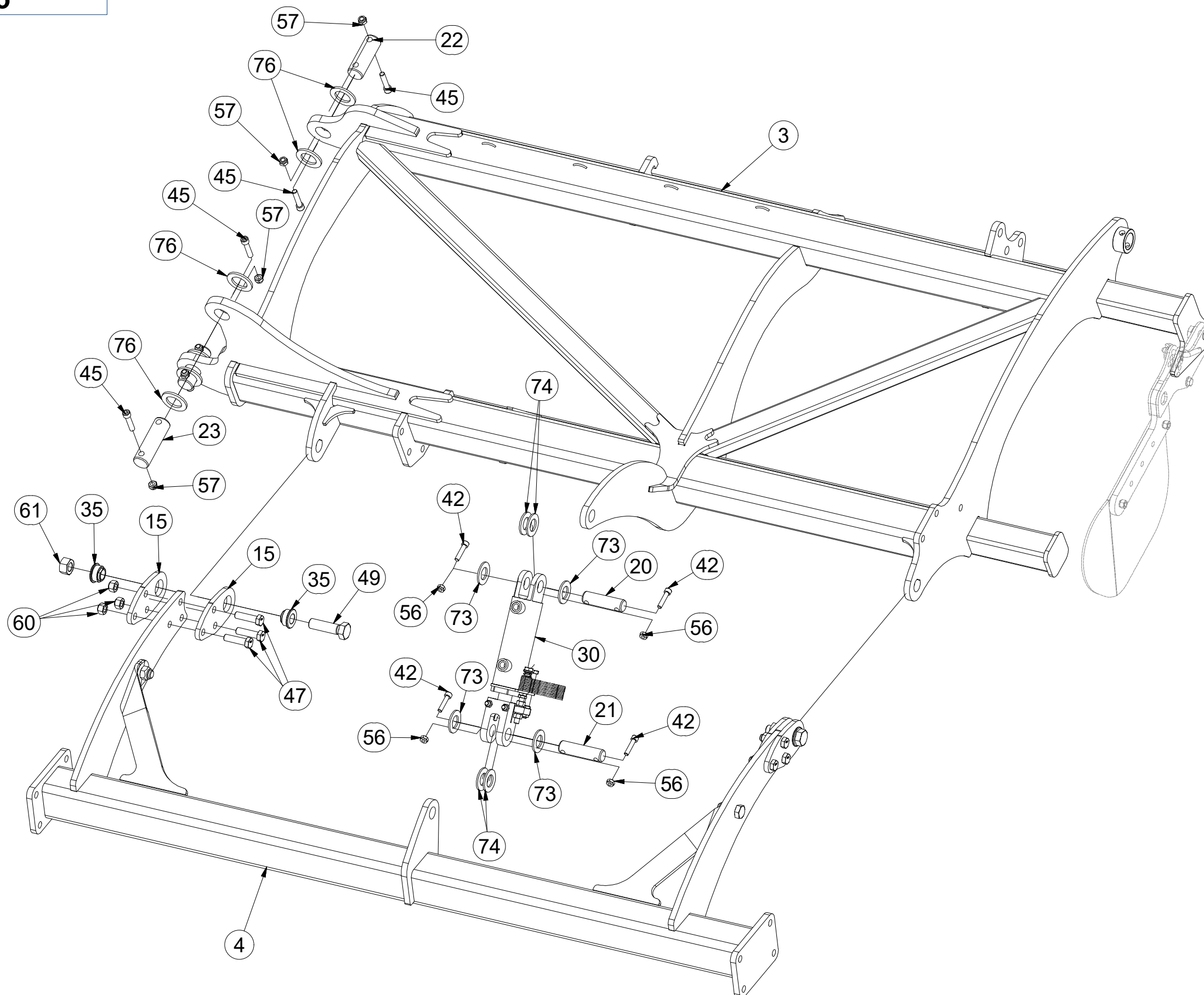

Pos.	Part Number	Pcs.
3	2000850	1
4	3008699	1
15	4014704	8
20	4007584	2
21	4007639	2
22	4007592	4
23	4007816	5
30	4015781	2
35	m14506	8
42	m14143	8
45	m14008	28
47	m14482	12
49	m08532	4
56	m03775	8
57	m04301	28
60	m12150	12
61	m13009	10
73	m14029	8
74	m02866	8
76	4013139	28



Ⓒ ZÁKLAD STROJE

Ⓓ UNTERBAU DER MASCHINE

Ⓕ BÂTI DE LA MACHINE

Ⓖ FOOTING OF THE MACHINE

Ⓡ ОСНОВАНИЕ МАШИНЫ

Ⓢ PODSTAWA MASZYNY



**3009675**

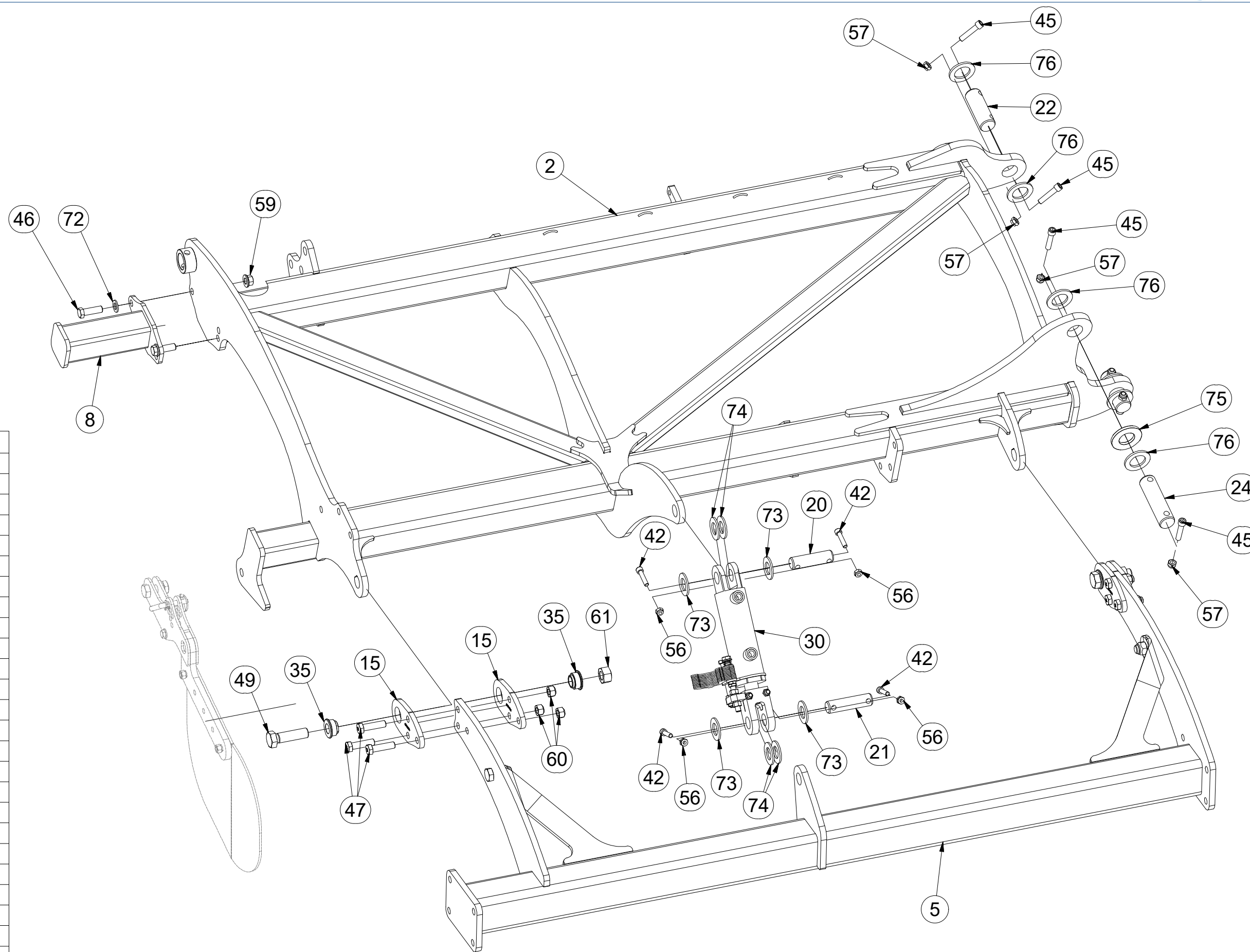

Pos.	Part Number	Pcs.
2	2000849	1
5	3008697	1
8	3007071	1
15	4014704	8
20	4007584	2
21	4007639	2
22	4007592	4
24	4012990	5
30	4015781	2
35	m14506	8
42	m14143	8
45	m14008	28
46	m04355	2
47	m14482	12
49	m08532	4
56	m03775	8
57	m04301	28
59	m15730	2
60	m12150	12
61	m13009	10
72	m01219	2
73	m14029	8
74	m02866	8
75	m03636	12
76	4013139	28

Ⓒ ZÁKLAD STROJE

Ⓓ UNTERBAU DER MASCHINE

Ⓕ BÂTI DE LA MACHINE

Ⓖ FOOTING OF THE MACHINE

Ⓡ ОСНОВАНИЕ МАШИНЫ

Ⓢ PODSTAWA MASZYNY



**3009675**

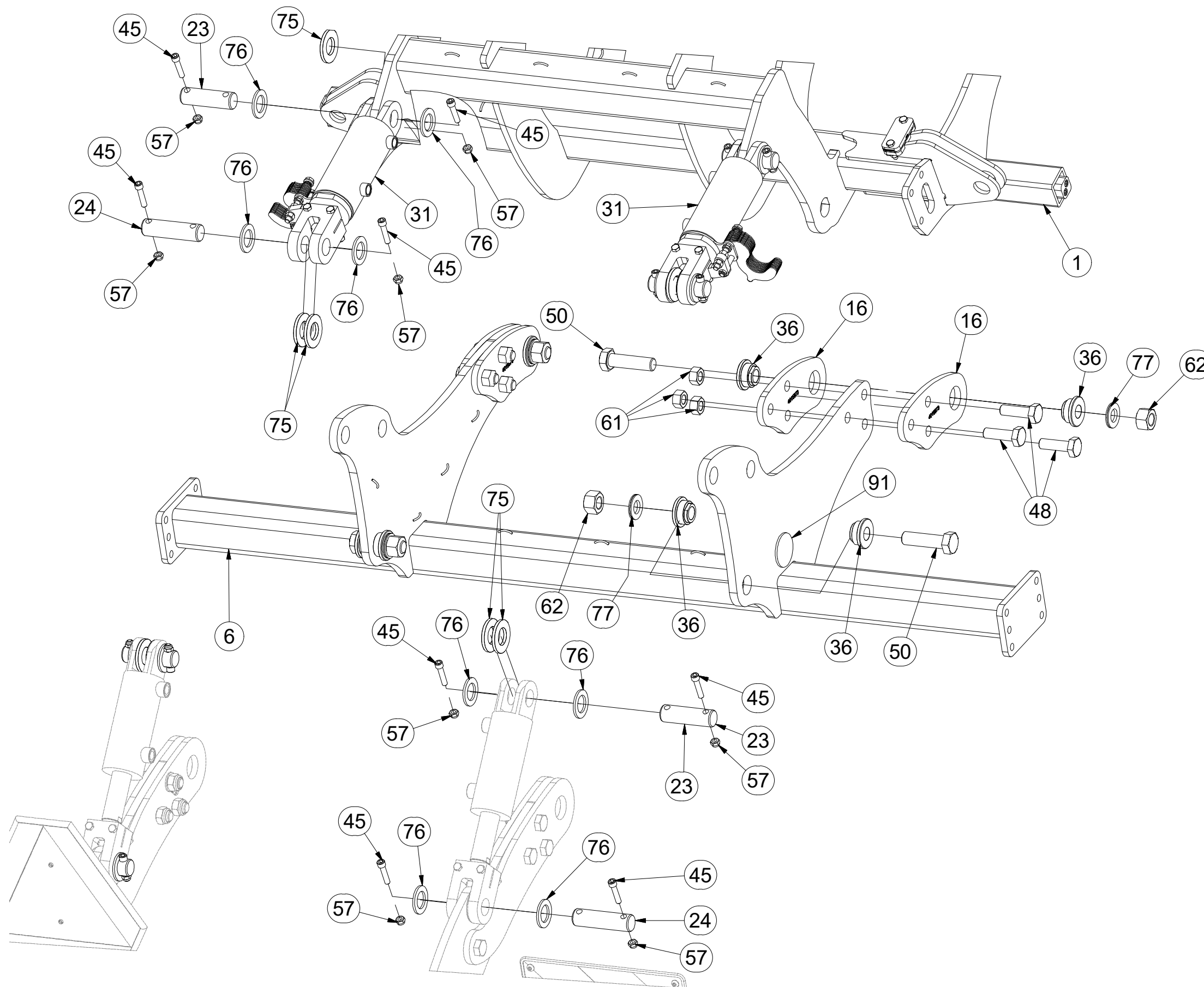

Pos.	Part Number	Pcs.
1	1000585	1
6	3008698	1
16	4015673	4
23	4007816	5
24	4012990	5
31	4015782	2
36	m14505	8
45	m14008	28
48	m03401	6
50	m14497	4
57	m04301	28
61	m13009	10
62	m14498	4
75	m03636	12
76	4013139	28
77	m13906	4
91	m02579	2

- ⒸZ SADA DISKŮ
- Ⓓ SCHEIBENSATZ
- Ⓕ KIT DE DISQUES

- ⒼB DISC SET
- ⒺU КОМПЛЕКТ ДИСКОВ
- ⒽL ZESTAW TALERZY



**3008043**

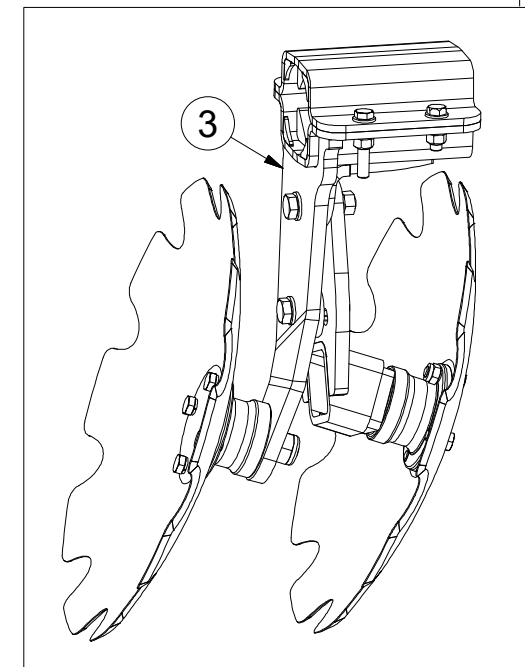
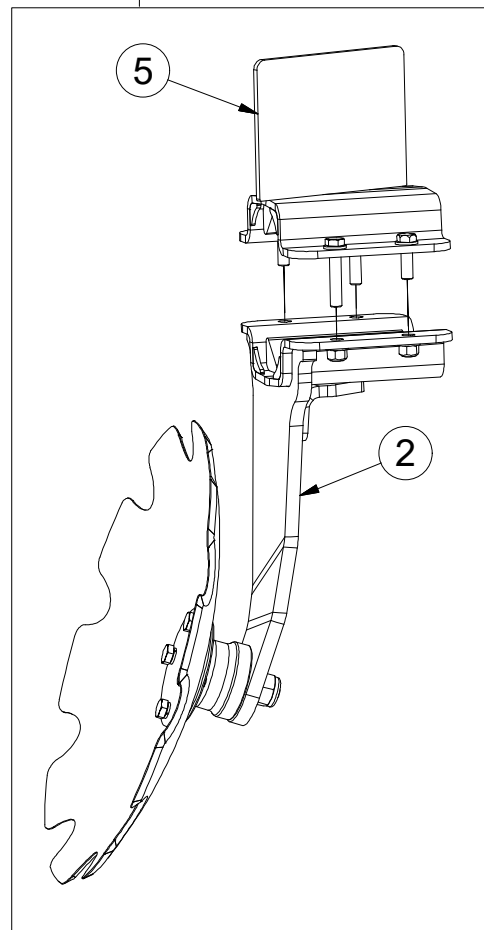
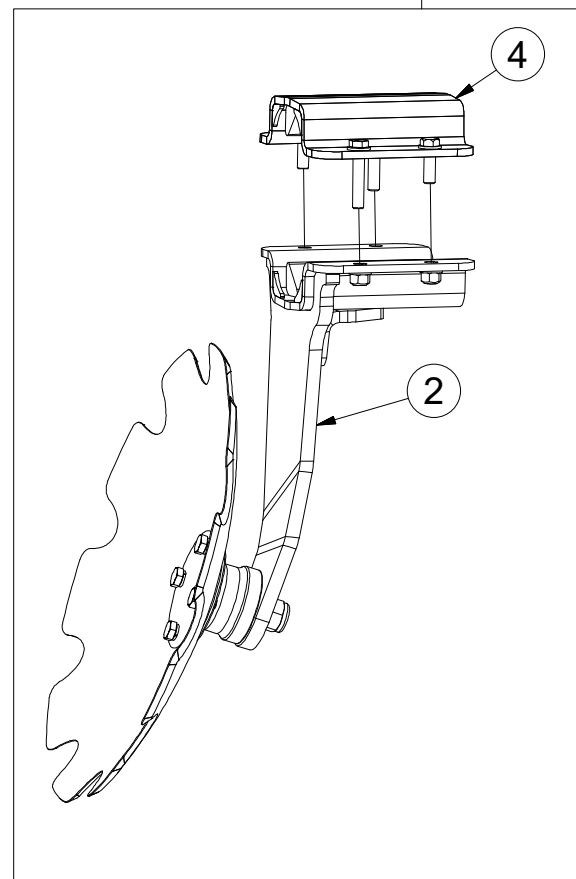
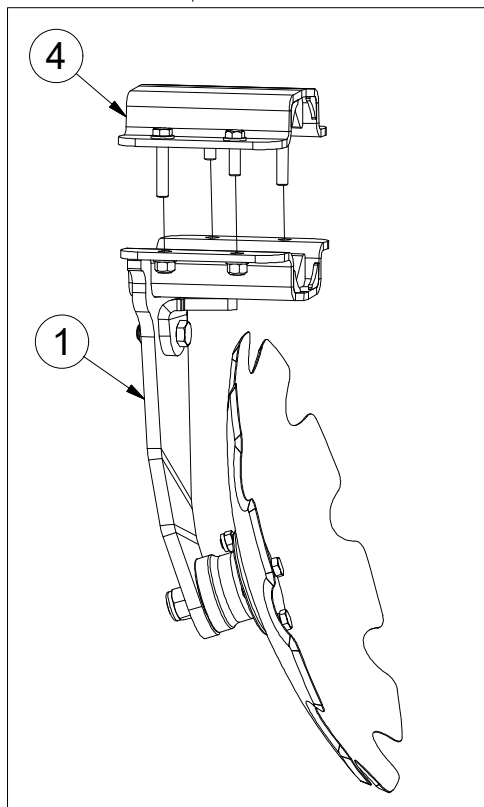
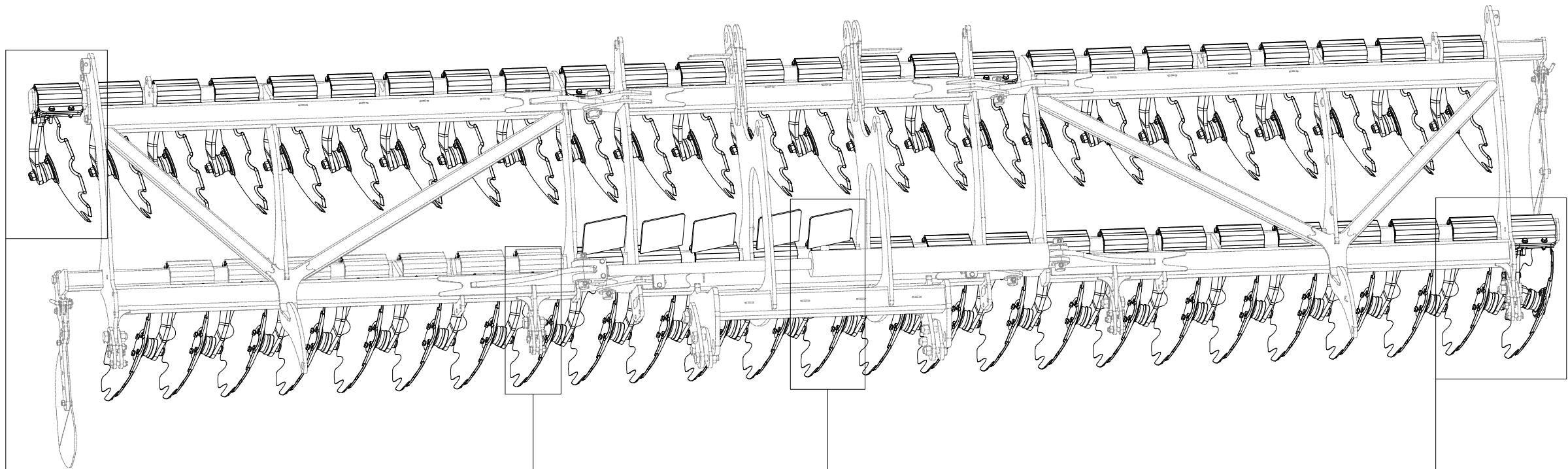

Pos.	Part Number	Pcs.
1	3008380	25
2	3008381	25
3	3008378	1
4	9004269	43
5	4016392	5

CZ PŘEDNÍ DISK  
 D SCHEIBE, VORDERE  
 F DISQUE AVANT

GB FRONT DISC  
 RU ДИСК ПЕРЕДНИЙ  
 PL TALERZ PRZEDNI



**3008380**

Pos.	Part Number	Pcs.
1	3008386	1
2	3007653	1
4	4007853	1
5	4016362	4
10	m11308	1
15	m11309	3
16	m09977	2
17	m14423	2
18	m11559	1
20	m11313	1
21	m12134	4
22	m11560	1
25	m03988	4
26	m01214	8

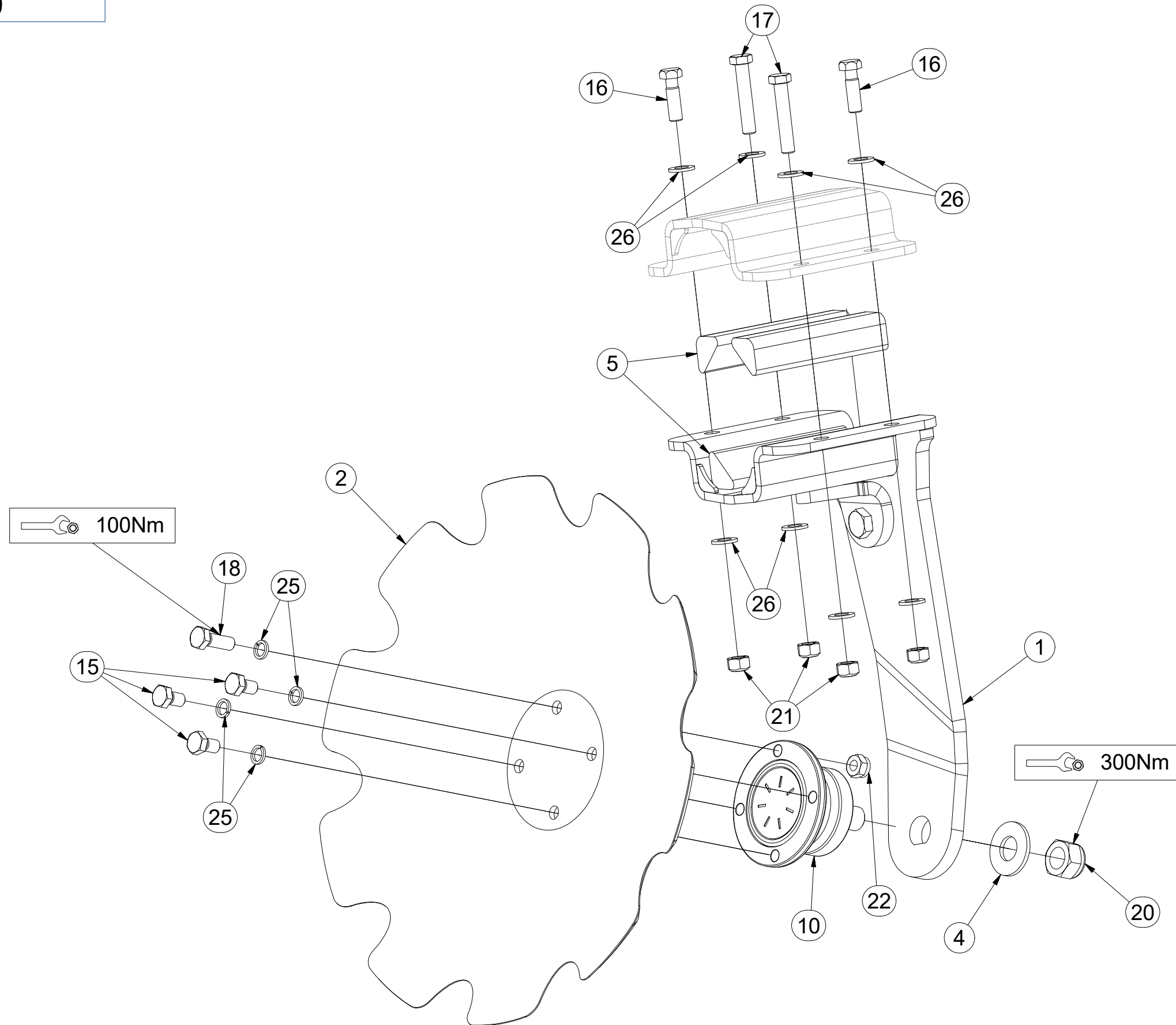

CZ ZADNÍ DISK  
 D SCHEIBE, HINTERE  
 F DISQUE ARRIÈRE

GB REAR DISC  
 RU ДИСК ЗАДНИЙ  
 PL TALERZ TYLNY



**3008381**

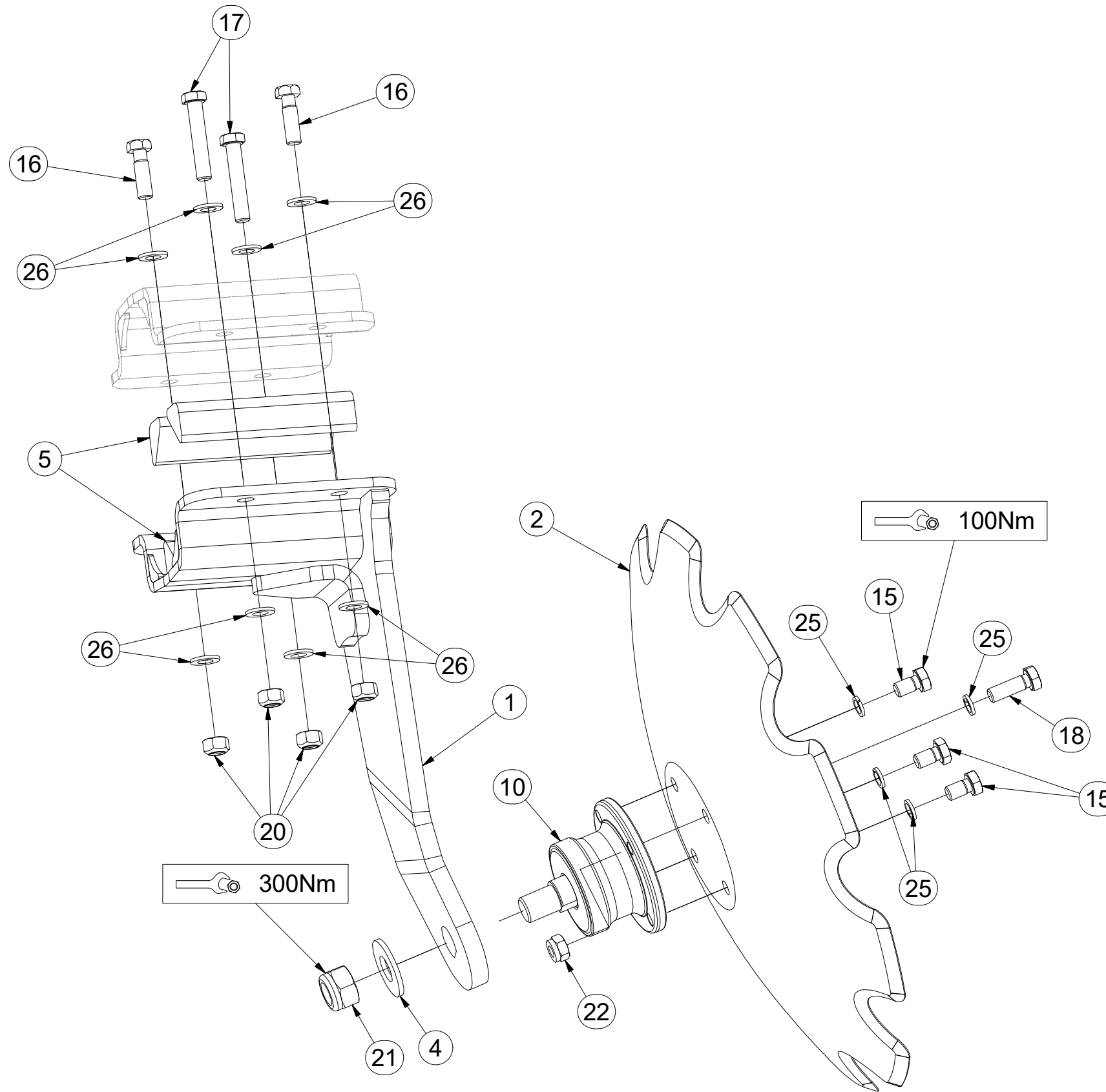

Pos.	Part Number	Pcs.
1	3008387	1
2	3007653	1
4	4007853	1
5	4016362	4
10	m11308	1
15	m11309	3
16	m09977	2
17	m14423	2
18	m11559	1
20	m12134	4
21	m11313	1
22	m11560	1
25	m03988	4
26	m01214	8

Ⓒ ZADNÍ DVOUDISK

Ⓓ DUPLEXSCHEIBE, HINTERE

Ⓕ ARRIÈRE DISQUE DOUBLE

Ⓒ REAR TWIN DISC

Ⓓ ДВОЙНОЙ ДИСК ЗАДНИЙ

Ⓕ TALERZ PODWÓJNY TYLNY



**3008378**

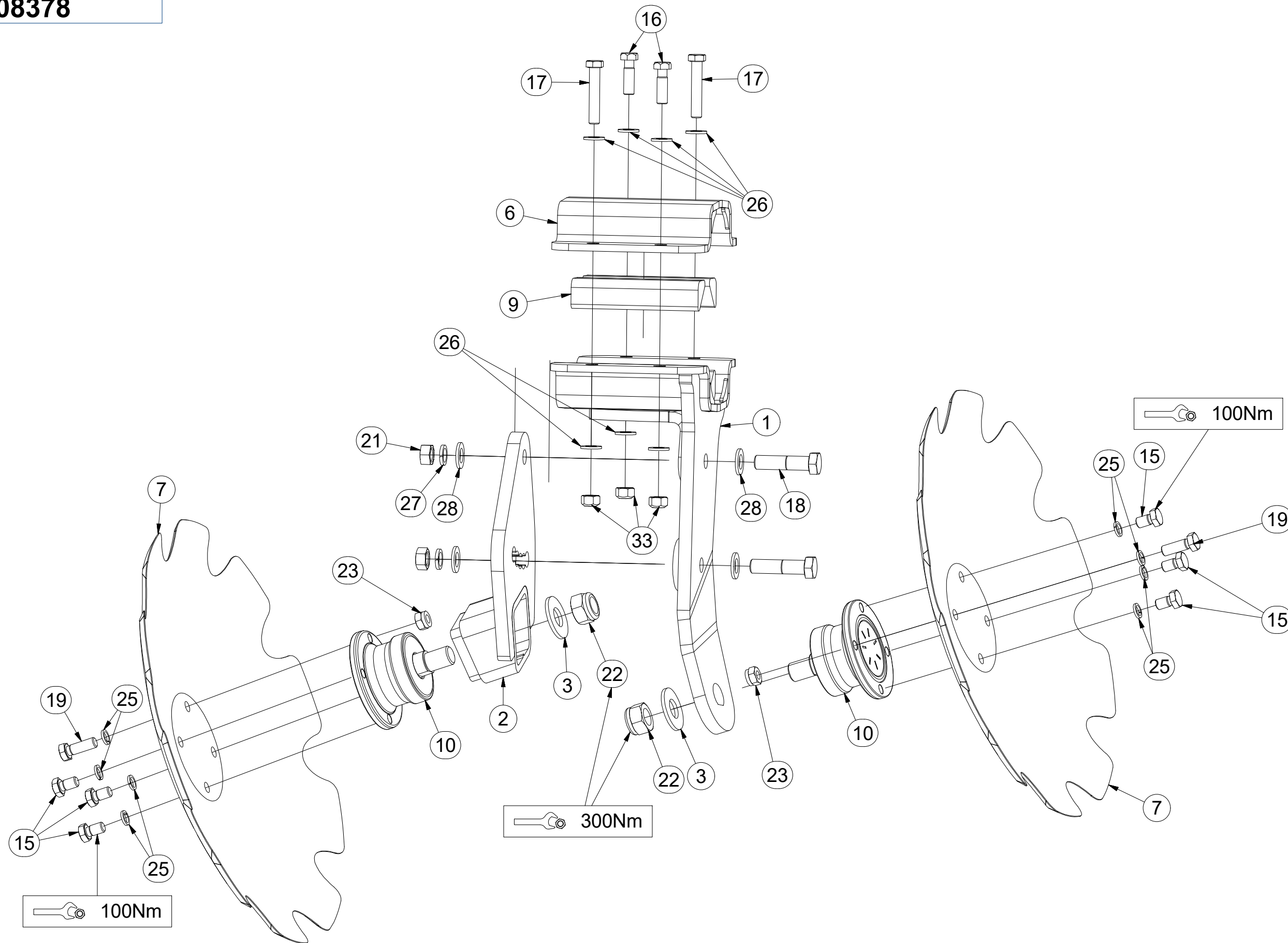

Pos.	Part Number	Pcs.
1	3008388	1
2	3004210	1
3	4007853	2
6	9004269	1
7	3007653	2
9	4016362	4
10	m11308	2
15	m11309	6
16	m09977	2
17	m14423	2
18	m06587	2
19	m11559	2
21	m01306	2
22	m11313	2
23	m11560	2
25	m03988	8
26	m01214	8
27	m02157	2
28	m01219	4
33	m12134	4

Ⓒ SADA DEFLEKTORŮ

Ⓓ DEFLEKTORSATZ

Ⓕ KIT DE DÉFLECTEURS

**3009573**

Ⓖ SET OF DEFLECTORS

Ⓡ КОМПЛЕКТ ДЕФЛЕКТОРОВ

Ⓟ ZESTAW DEFLEKTORÓW

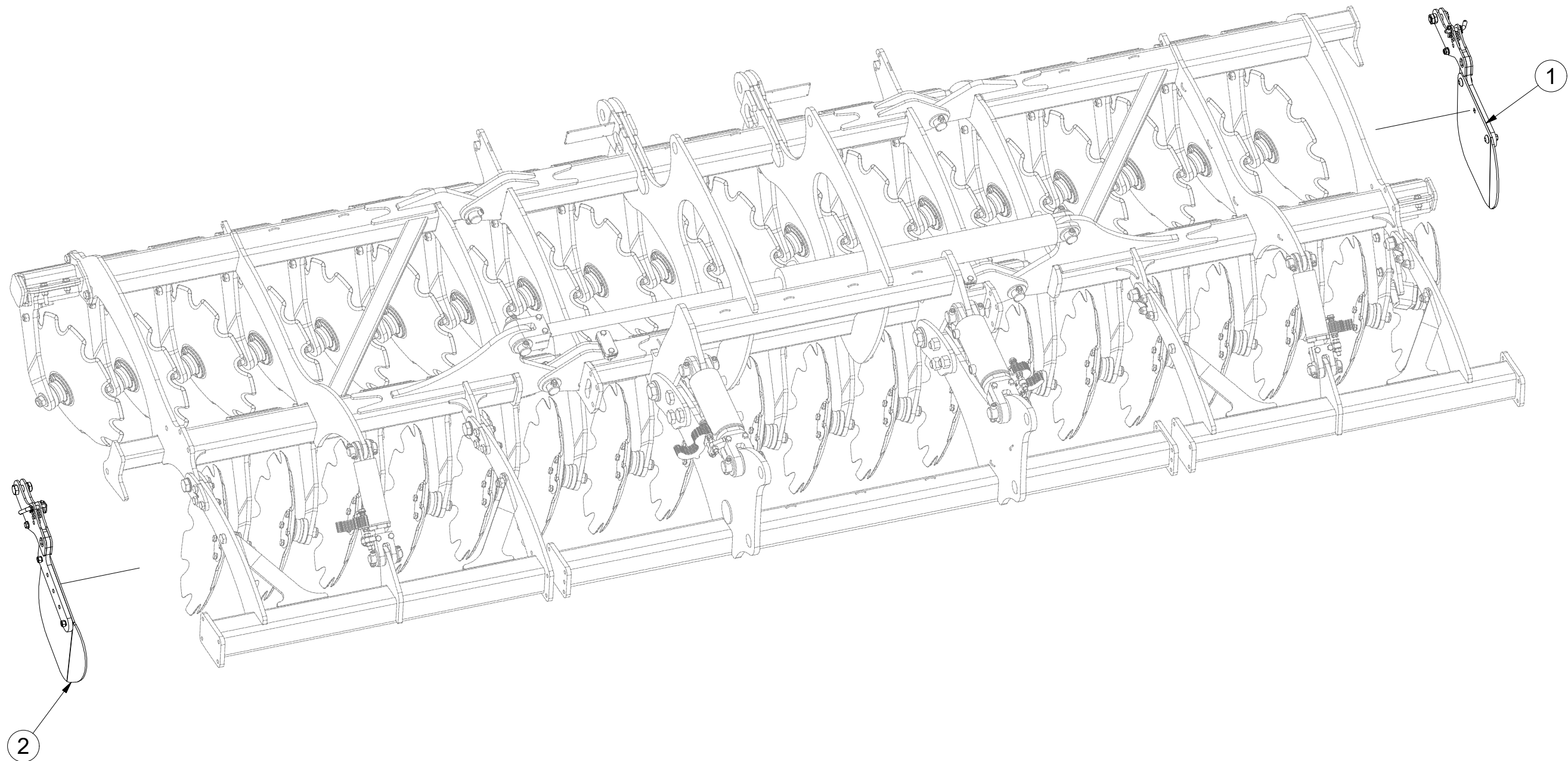

Pos.	Part Number	Pcs.
1	3004586	1
2	3009574	1

CZ PŘEDNÍ DEFLEKTOR  
 D DEFLEKTOR, VORDERE  
 F DÉFLECTEUR AVANT

GB FRONT DEFLECTOR  
 RU ПЕРЕДНИЙ ДЕФЛЕКТОР  
 PL DEFLOKTOR PRZEDNI



**3004586**

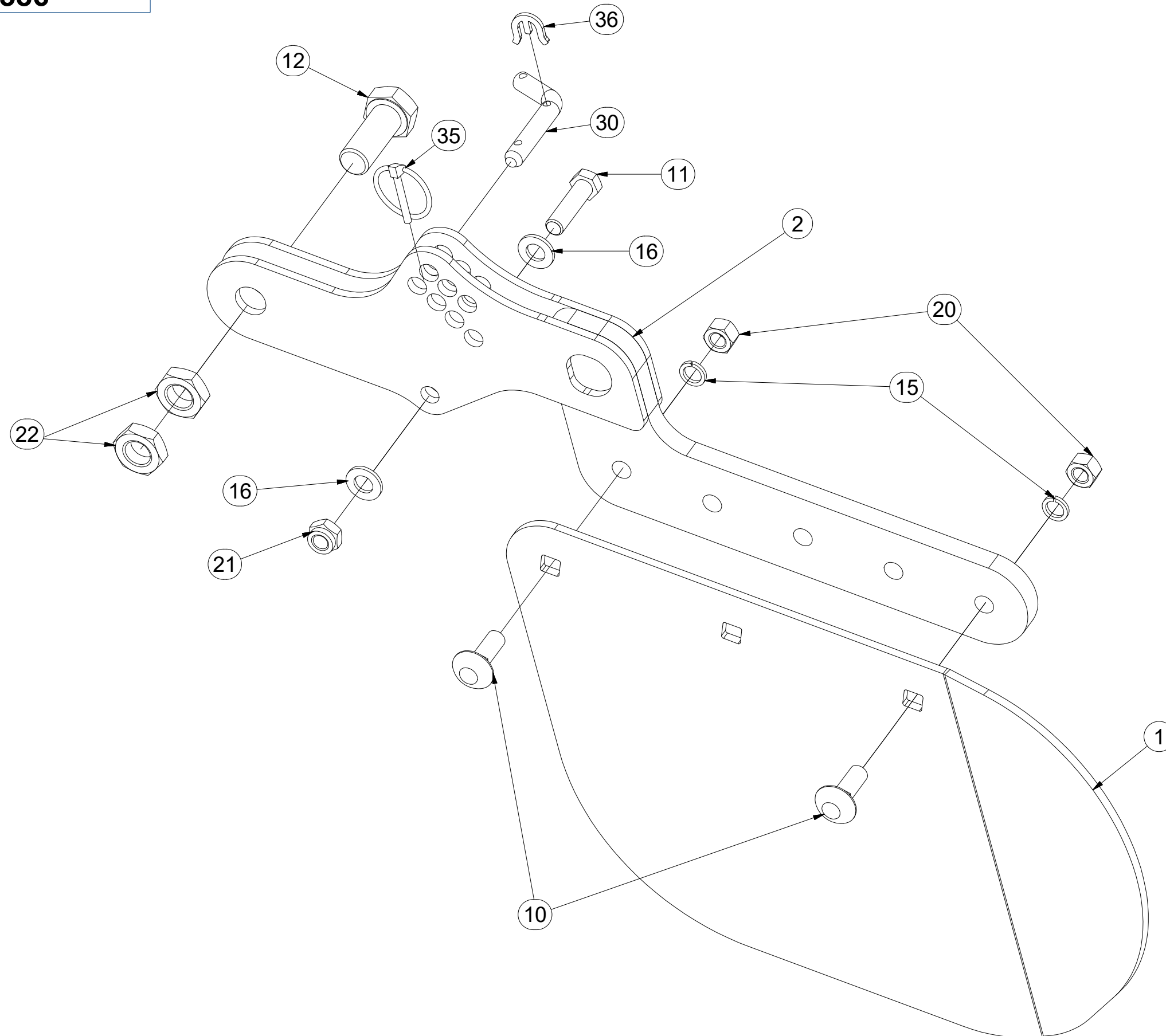

Pos	Part Number	Pcs.
1	4008155	1
2	4008743	1
10	m10618	2
11	m06077	1
12	m08378	1
15	m03988	2
16	m01214	2
20	m10439	2
21	m04301	1
22	m04284	2
30	m09141	1
35	m10454	1
36	4016279	1



CZ ZADNÍ DEFLEKTOR  
 D DEFLEKTOR, HINTERE  
 F DÉFLECTEUR ARRIÈRE

GB REAR DEFLECTOR  
 RU ЗАДНИЙ ДЕФЛЕКТОР  
 PL DEFLEKTOR TYLNY



**3009574**

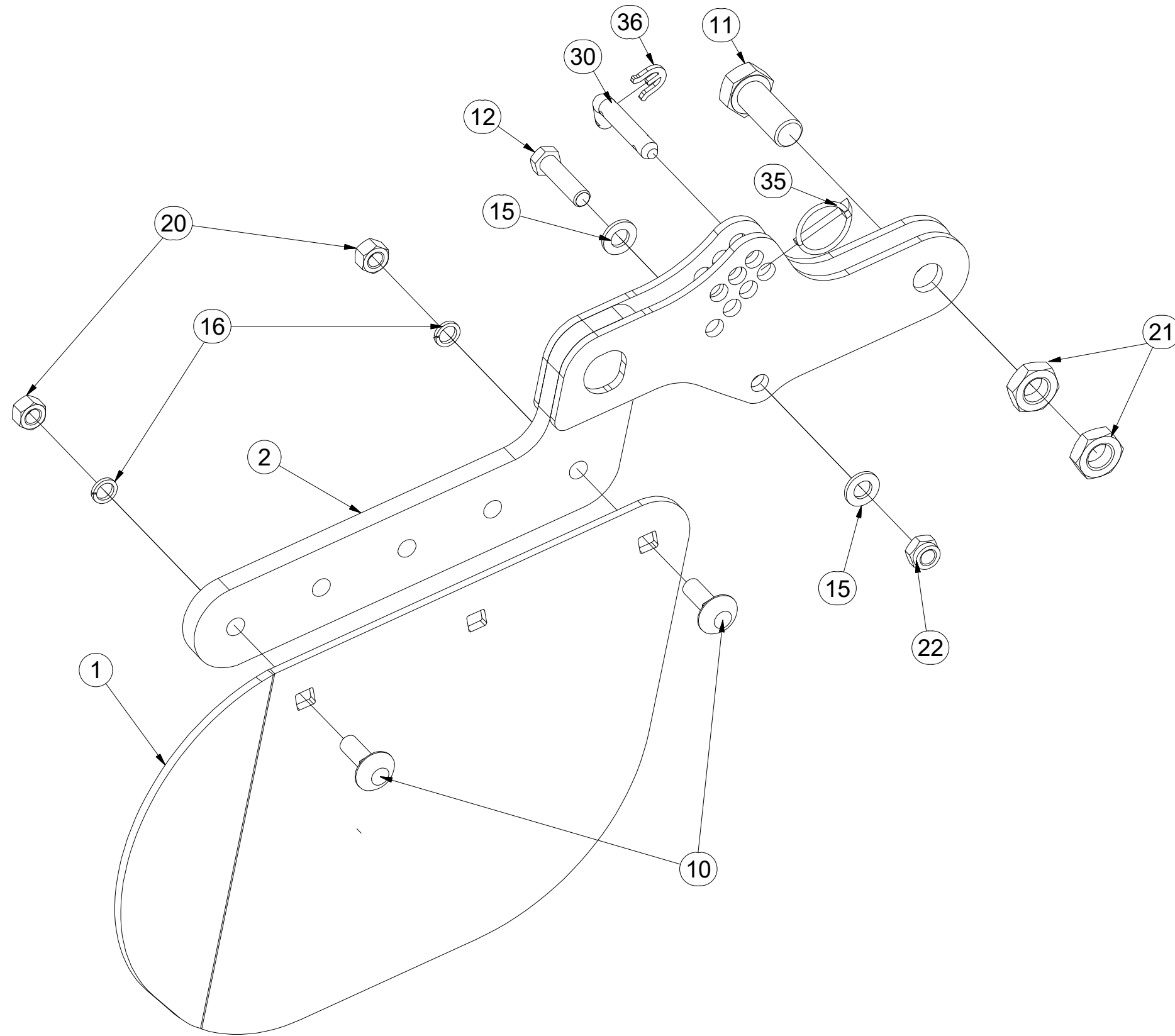

Pos	Part Number	Pcs.
2	4008743	1
10	m10618	2
11	m08378	1
12	m06077	1
15	m01214	2
16	m03988	2
20	m10439	2
21	m04284	2
22	m04301	1
30	m09141	1
35	m10454	1
36	4016279	1
1	4008981	1

ⒸZ DVOUVÁLCE

Ⓓ DUPLEXWALZEN

Ⓕ ROULEAU DOUBLE

ⒸB TWIN ROLLERS

ⒸU ДВОЙНЫЕ КАТКИ

ⒸL WAŁ PODWÓJNY



**3008695**

Pos.	Part Number	Pcs.
1	2000765	1
2	3004564	1
3	3004604	2
4	3007733	2
5	3008709	2
6	3008724	1
7	3008728	3
8	3008729	3
9	3008700	2
10	3008702	2
11	3008701	1
12	3008703	1
16	4008981	1

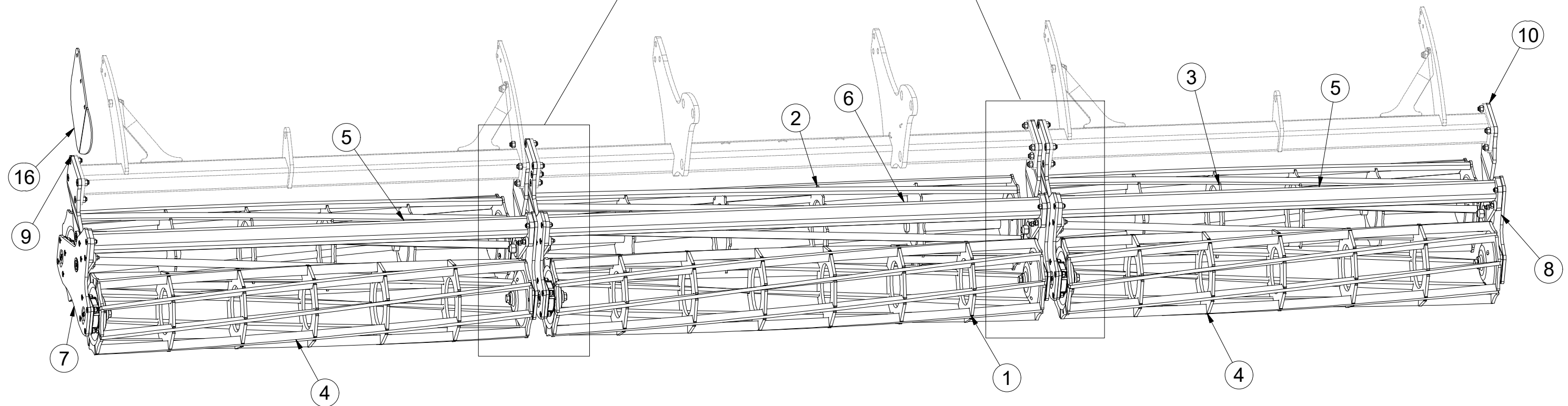
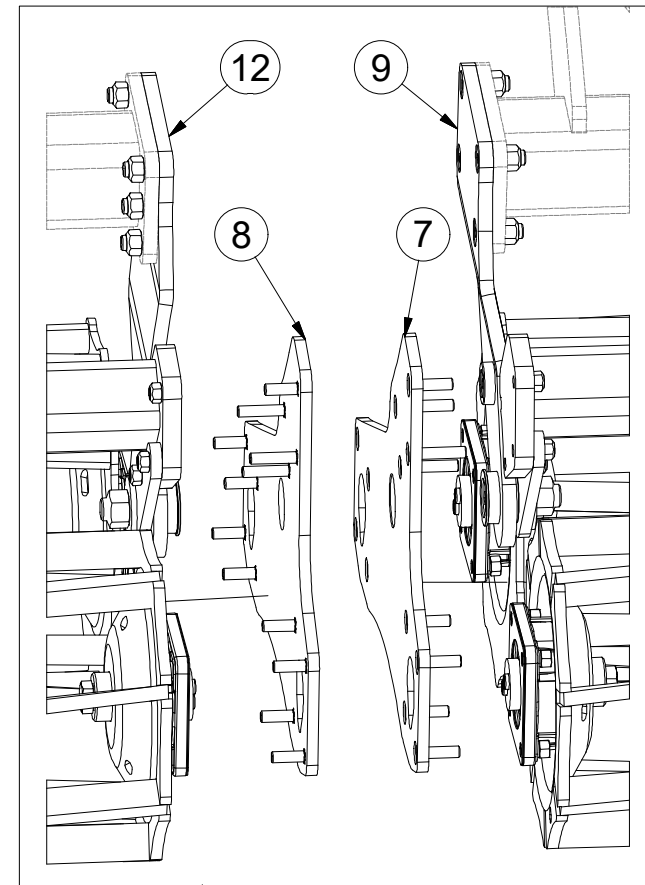
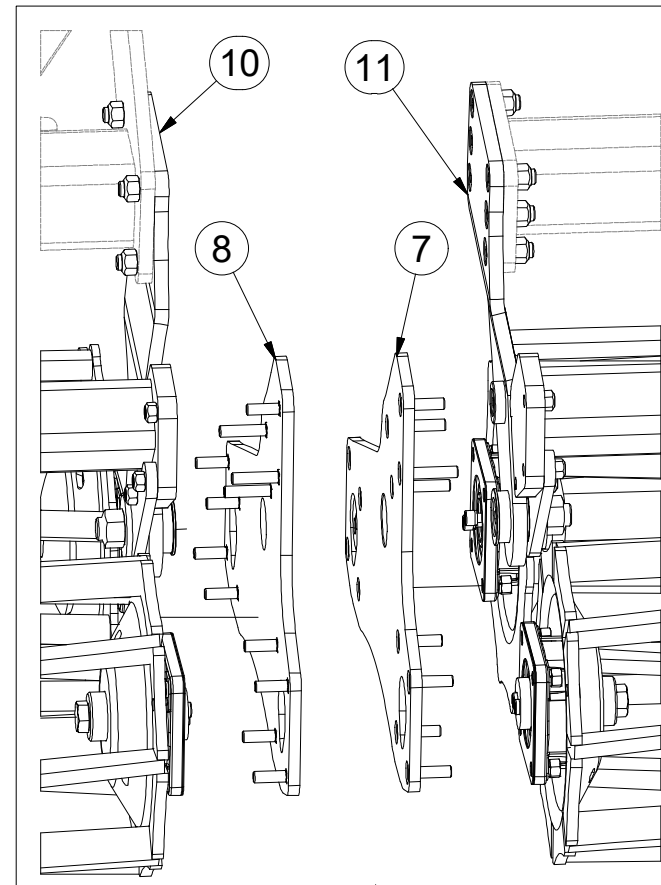

ⒸZ DVOUVÁLCE

Ⓓ DUPLEXWALZEN

Ⓕ ROULEAU DOUBLE

ⒼB TWIN ROLLERS

ⒺU ДВОЙНЫЕ КАТКИ

ⒼL WAŁ PODWÓJNY



**3008695**

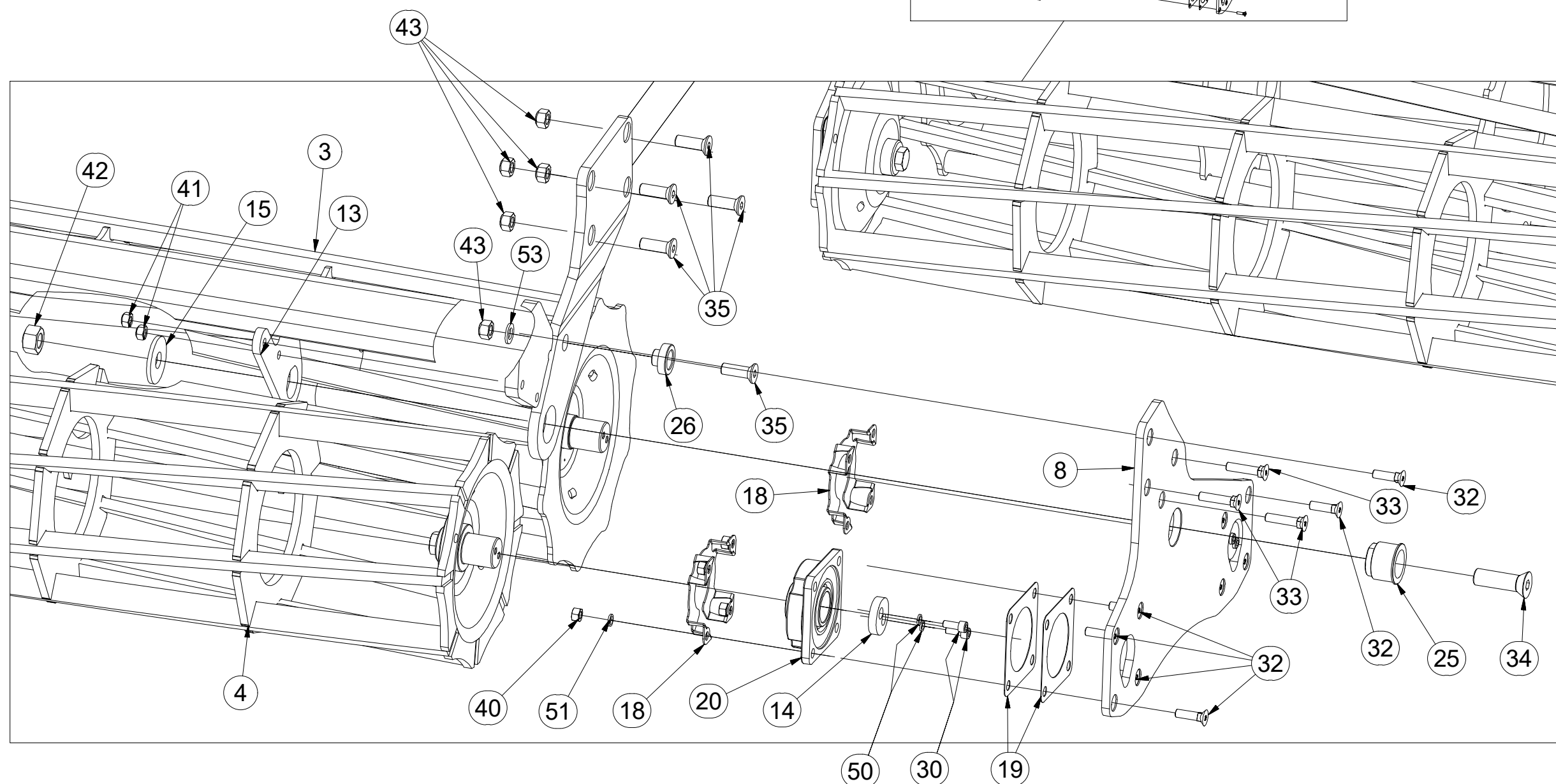
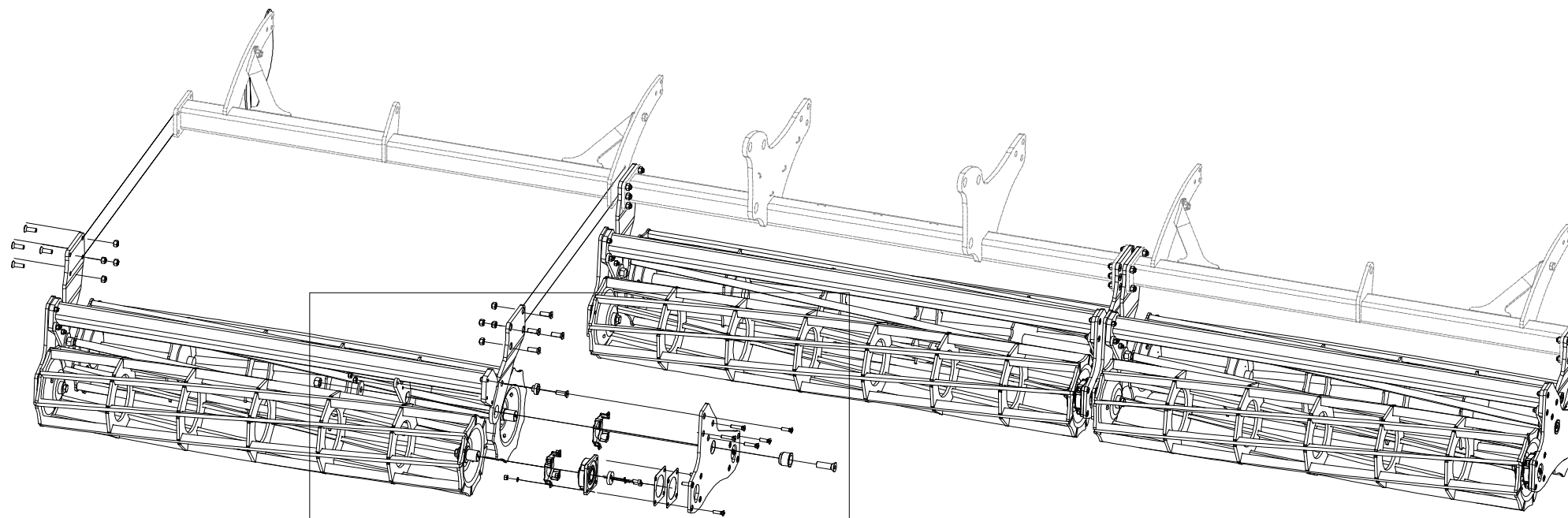

Pos.	Part Number	Pcs.
3	3004604	2
4	3007733	2
8	3008729	3
10	3008702	2
13	4015769	6
14	4017124	12
15	4015792	6
18	4017071	12
19	4016002	23
20	m15626	12
25	m14991	6
26	m15767	6
30	m04249	24
32	m11154	54
33	m14993	18
34	m14992	6
35	m14672	34
40	m01305	48
41	m12134	24
42	m13009	6
43	m13846	34
50	m01208	24
51	m03988	48
53	m01219	6

Ⓒ SADA NÁPRAVY

Ⓓ SATZ AUFHÄNGUNG

Ⓕ KIT DE L'ESSIEU

Ⓖ AXLE SET

Ⓡ КОМПЛЕКТ ОСИ КОЛЁС

Ⓢ ZESTAW OSI



**3009674**

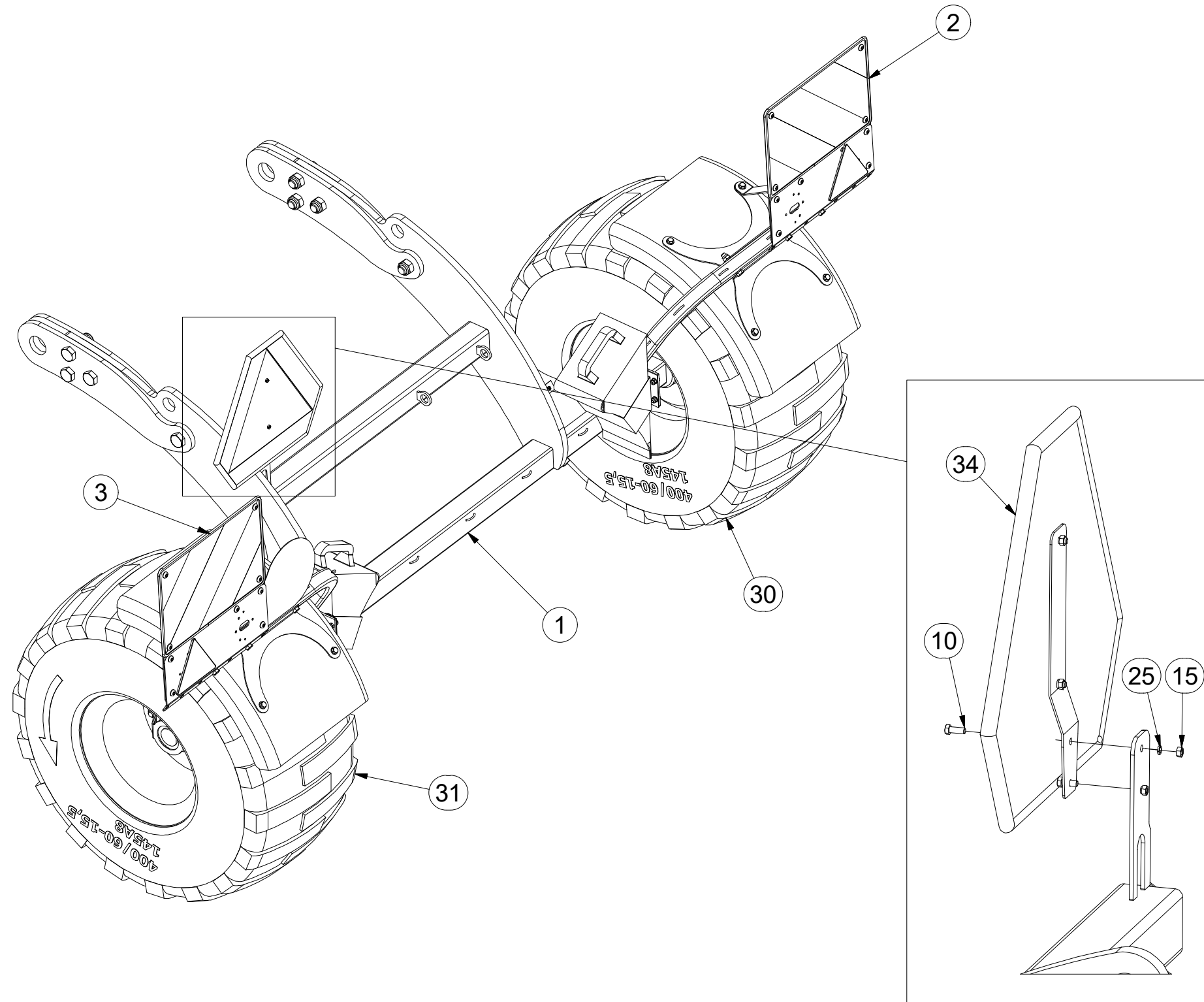

Pos.	Part Number	Pcs.
1	3008011	1
2	3009530	1
3	3009529	1
10	m01073	2
15	m01295	2
25	m01200	2
30	m14346	1
31	m14348	1
34	m05371	1

Ⓒ SADA NÁPRAVY

Ⓓ SATZ AUFHÄNGUNG

Ⓕ KIT DE L'ESSIEU

Ⓖ AXLE SET

Ⓡ КОМПЛЕКТ ОСИ КОЛЁС

Ⓟ ZESTAW OSI



**3009674**

Pos.	Part Number	Pcs.
1	3008011	1
4	4015682	4
5	4015765	2
13	m14990	8
19	m07147	8
40	m13554	2

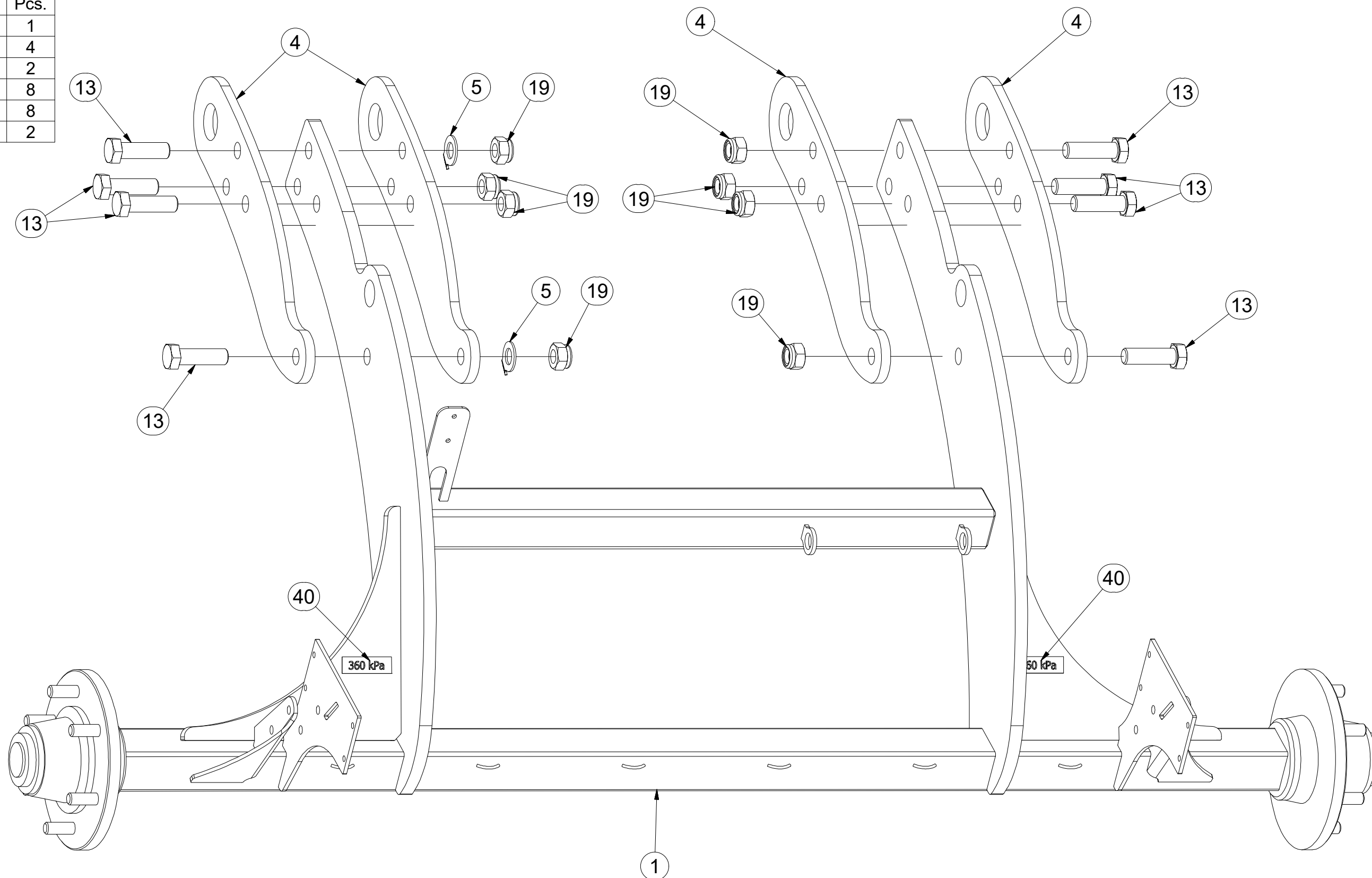

Ⓒ SADA NÁPRAVY

Ⓓ SATZ AUFHÄNGUNG

Ⓕ KIT DE L'ESSIEU

Ⓖ AXLE SET

Ⓡ КОМПЛЕКТ ОСИ КОЛЁС

Ⓢ ZESTAW OSI



**3009674**

Pos.	Part Number	Pcs.
1	3008011	1
3	3009529	1
6	3002647	2
11	m01089	8
12	m14266	4
16	m04503	8
17	m06233	4
18	m14902	4
26	m01203	8
31	m14348	1
32	m16186	2
33	m12572	2

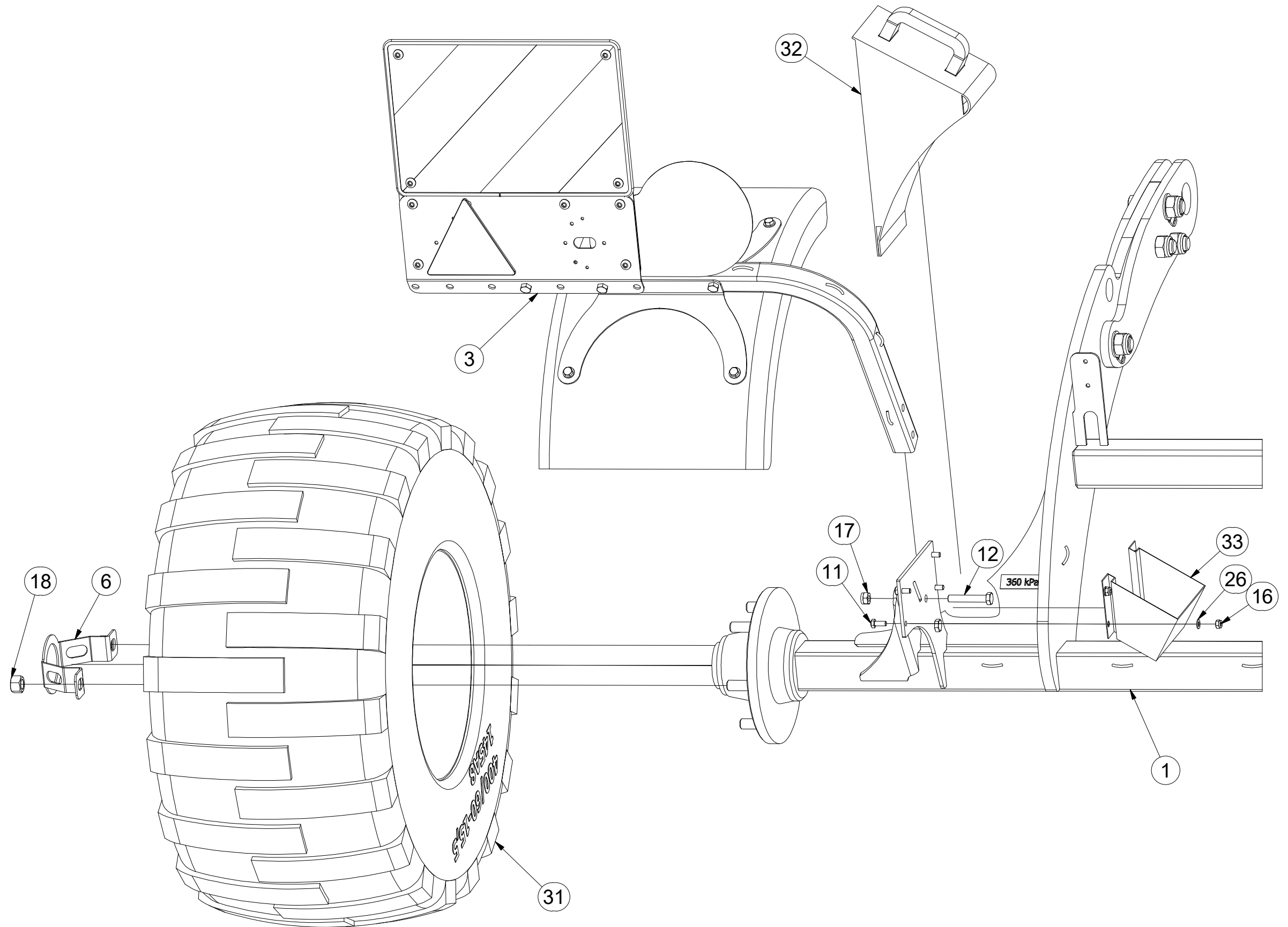

ⒸZ SADA NÁPRAVY

Ⓓ SATZ AUFHÄNGUNG

Ⓕ KIT DE L'ESSIEU

ⒼB AXLE SET

ⒶR KOMПЛЕКТ ОСИ КОЛЁС

ⒶL ZESTAW OSI



**3009674**

Pos.	Part Number	Pcs.
1	3008011	1
2	3009530	1
6	3002647	2
11	m01089	8
12	m14266	4
16	m04503	8
17	m06233	4
18	m14902	4
26	m01203	8
30	m14346	1
32	m16186	2
33	m12572	2

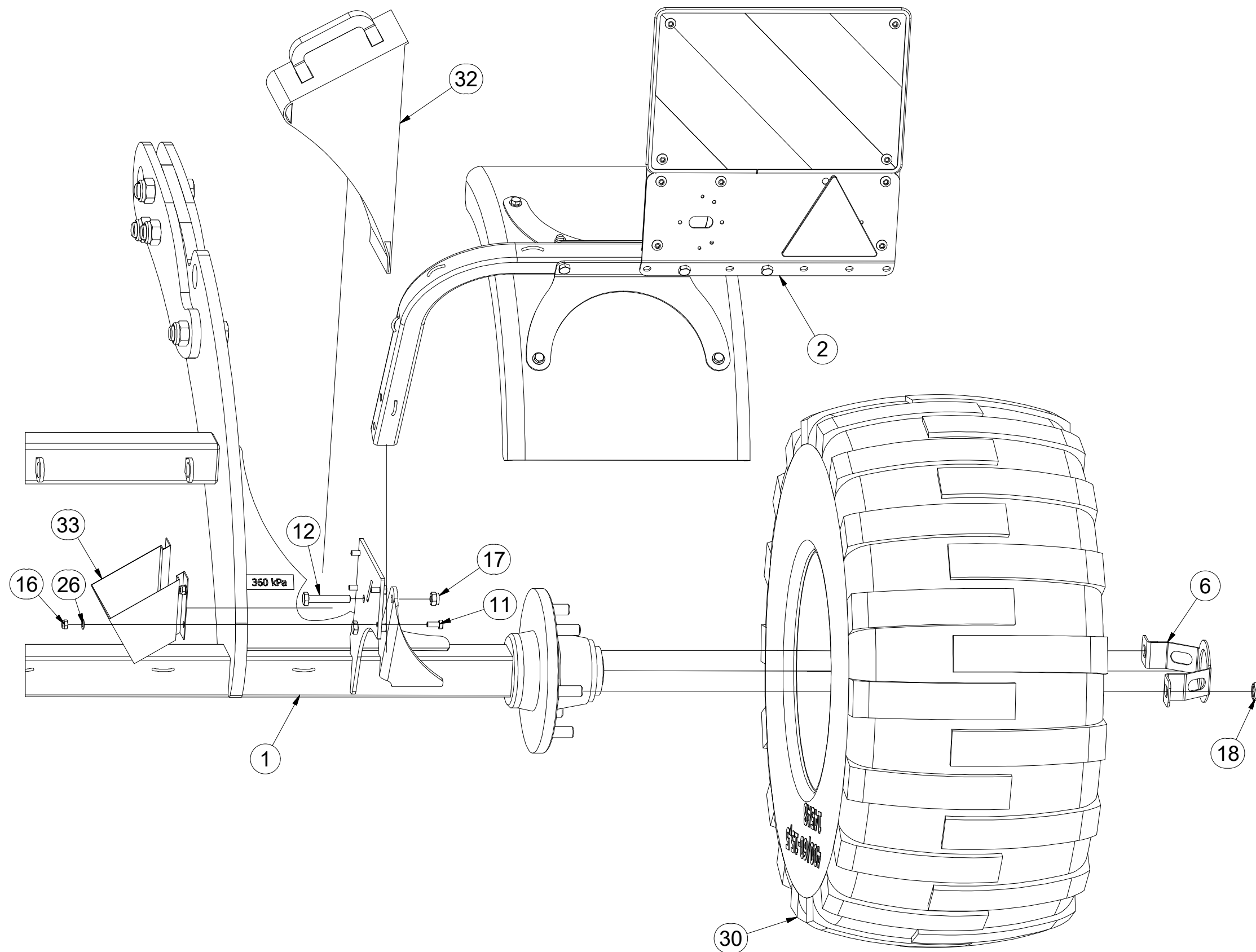

Ⓒ NÁPRAVA

Ⓓ ACHSE

Ⓕ ESSIEU

Ⓖ AXLE

Ⓡ OCB

Ⓟ OS



**A70MR06**

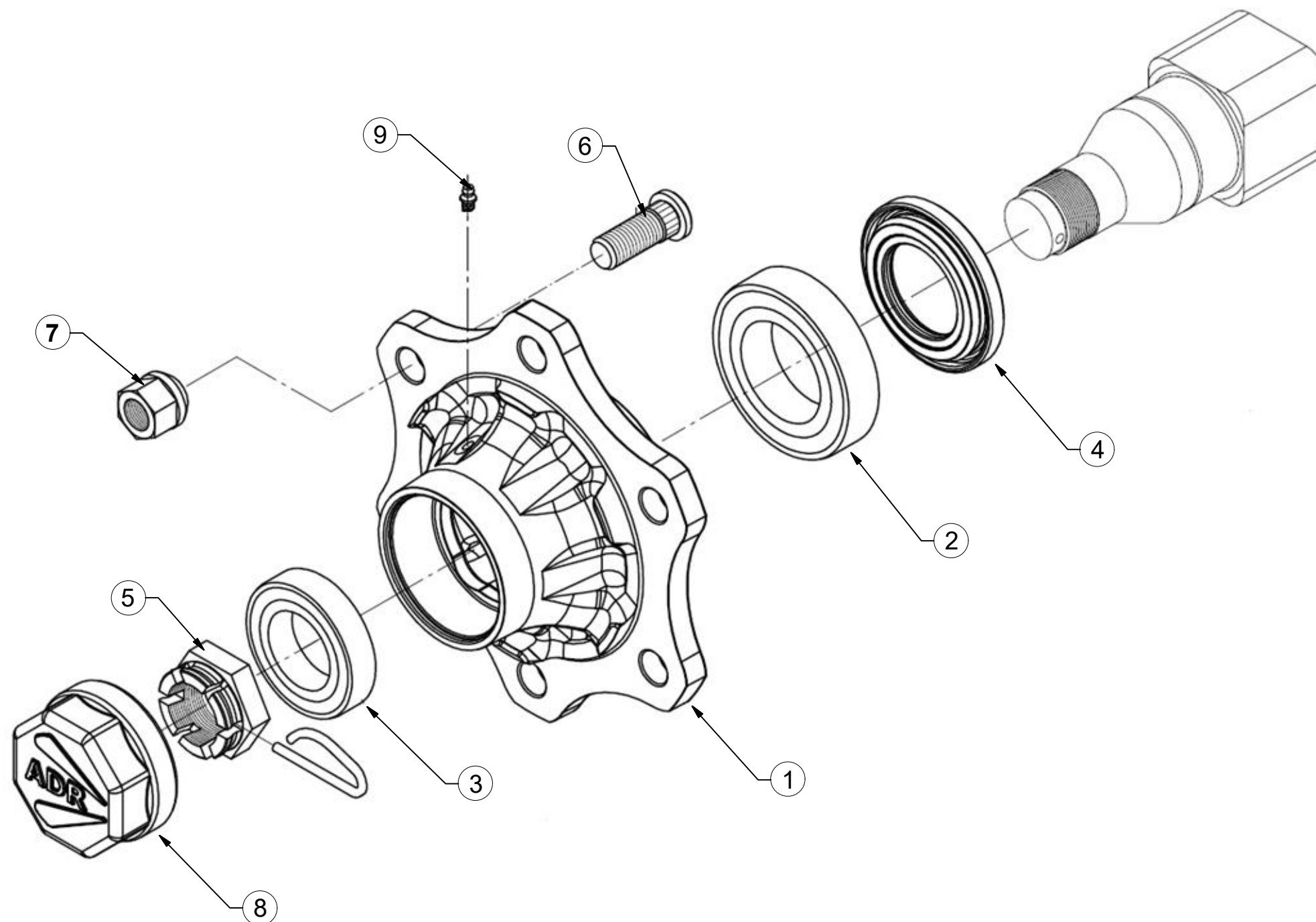

Pos	Part Number	Pcs.
1	m14910	2
2	m08194	2
3	m07152	2
4	m14924	2
5	m08169	2
6	m08148	12
7	m08163	12
8	m14923	2
9	m05698	2



ⒸZ HYDRAULIKA STROJE

Ⓓ HYDRAULIK DER MASCHINE

Ⓕ HYDRAULIQUE DE LA MACHINE

ⒸB MACHINE HYDRAULICS

ⒸR ГИДРАВЛИКА МАШИНЫ

ⒸL HYDRAULIKA MASZYNY



**3009215**

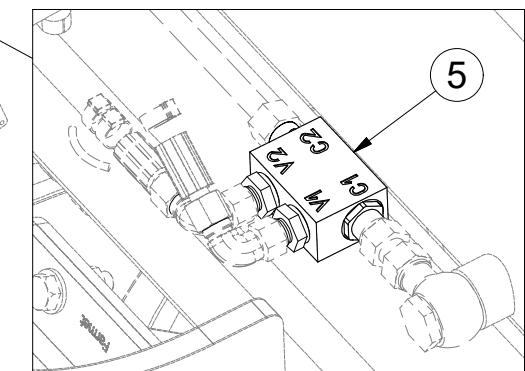
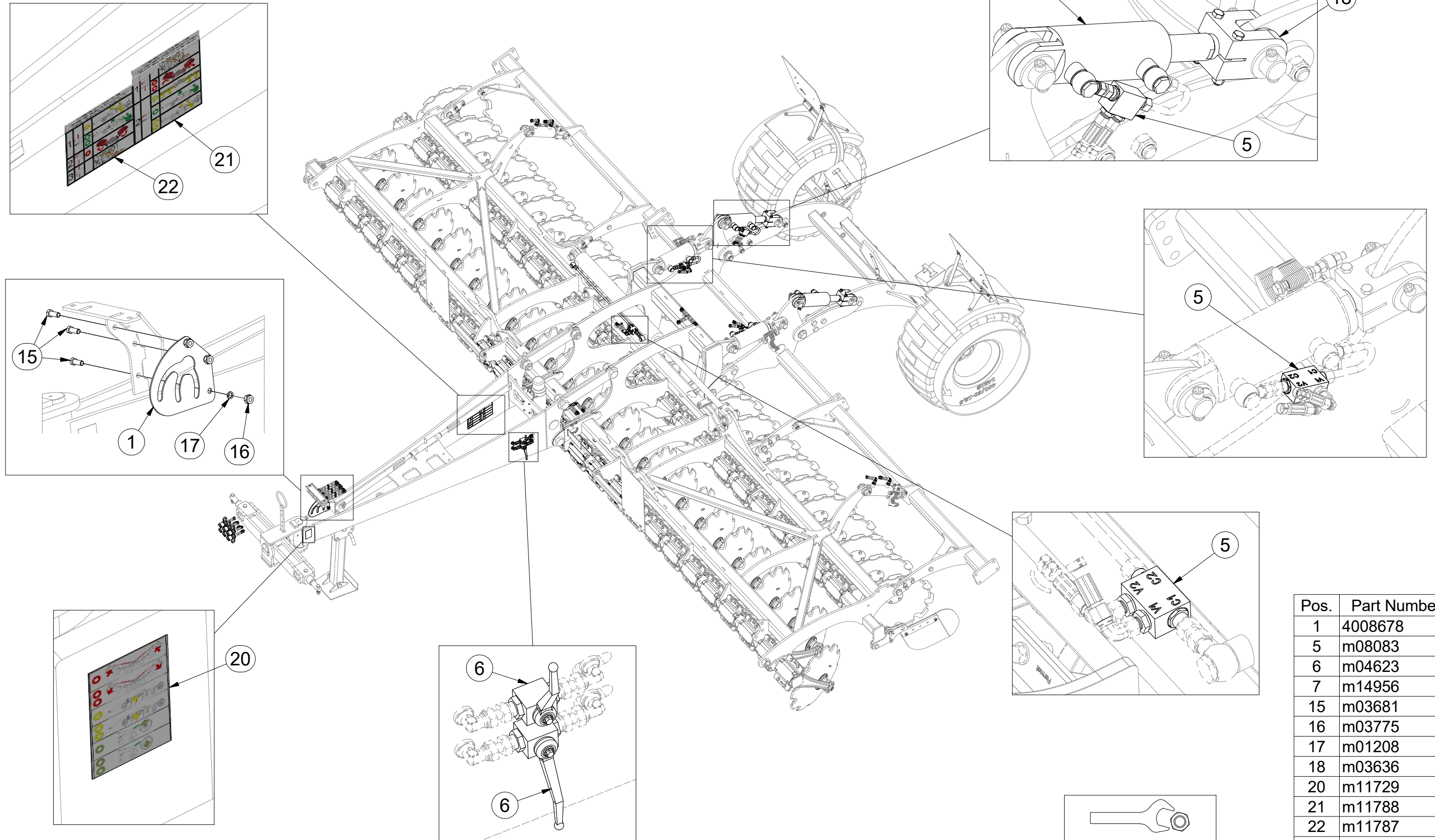

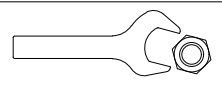
  
M10 (8.8) - 50Nm

Pos.	Part Number	Pcs.
1	4008678	1
5	m08083	5
6	m04623	2
7	m14956	2
15	m03681	3
16	m03775	3
17	m01208	3
18	m03636	2
20	m11729	1
21	m11788	1
22	m11787	1
30	m16007	1
40	m08011	9

ⒸZ HYDRAULICKÝ ROZVOD SKLÁPĚNÍ

Ⓓ HYDRAULISCHE VERTEILUNG KLAPPMCHANISMUS

Ⓕ CONDUIT HYDRAULIQUE DU BASCULEMENT

ⒸB HYDRAULIC FOLDING DISTRIBUTION

ⒸU ГИДРАВЛИЧЕСКОЕ РАСПРЕДЕЛЕНИЕ СКЛАДЫВАНИЯ

ⒸL HYDRAULICZNY PRZEWÓD SKŁADANIA



**8000789-30101**

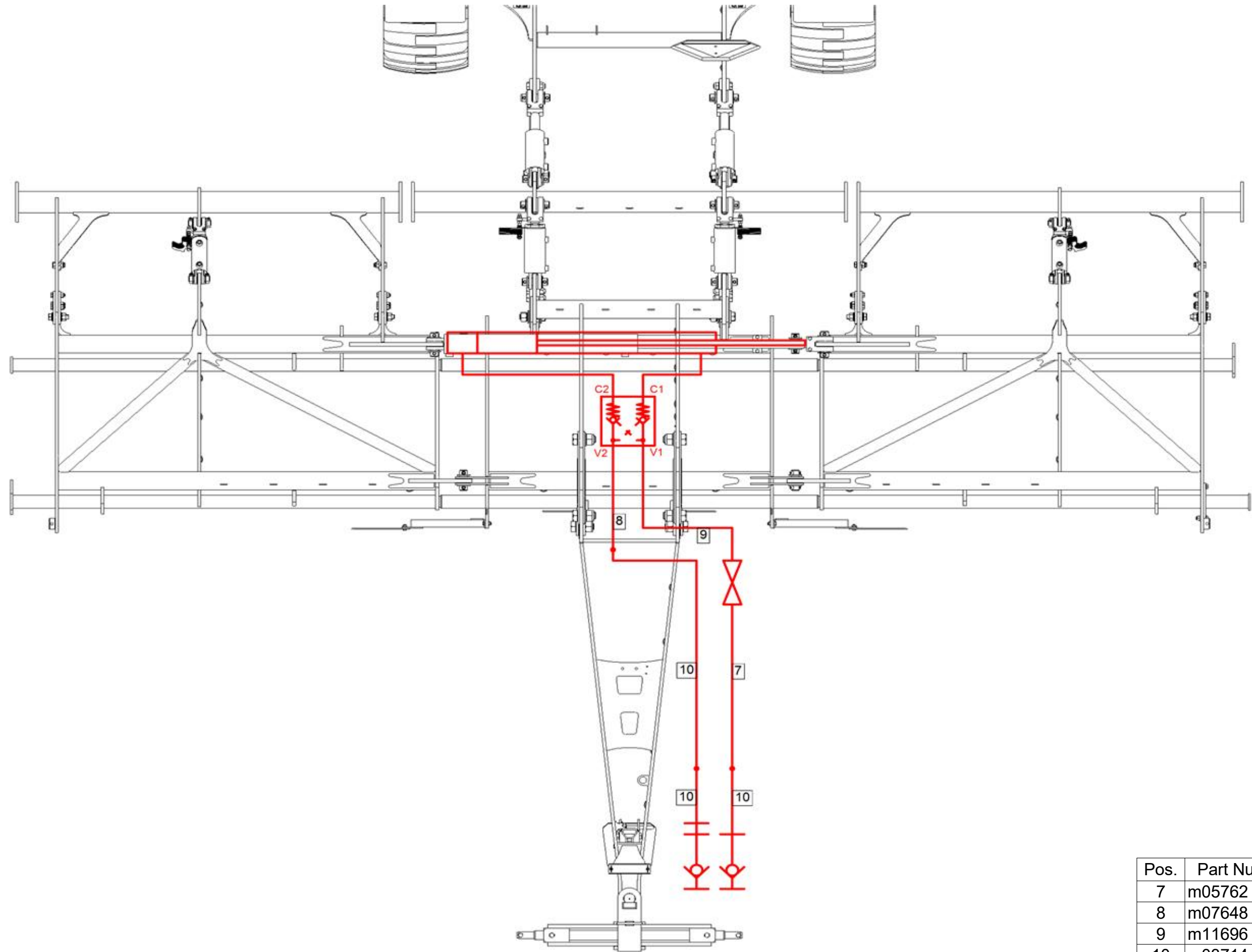

Pos.	Part Number	Pcs.
7	m05762	2
8	m07648	2
9	m11696	3
10	m03714	8

ⒸZ HYDRAULICKÝ ROZVOD SKLÁPĚNÍ

Ⓓ HYDRAULISCHE VERTEILUNG KLAPPMECHANISMUS

Ⓕ CONDUIT HYDRAULIQUE DU BASCULEMENT

ⒸB HYDRAULIC FOLDING DISTRIBUTION

ⒸU ГИДРАВЛИЧЕСКОЕ РАСПРЕДЕЛЕНИЕ СКЛАДЫВАНИЯ

ⒸL HYDRAULICZNY PRZEWÓD SKŁADANIA



**8000789-30101**

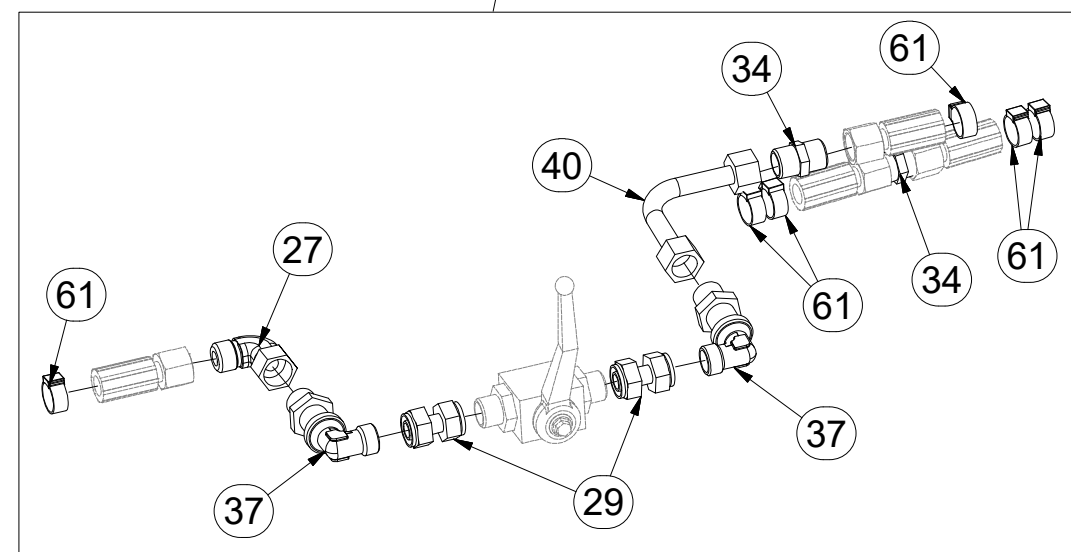
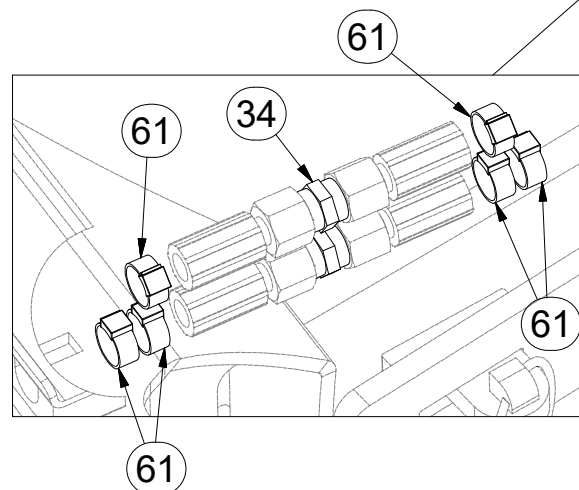
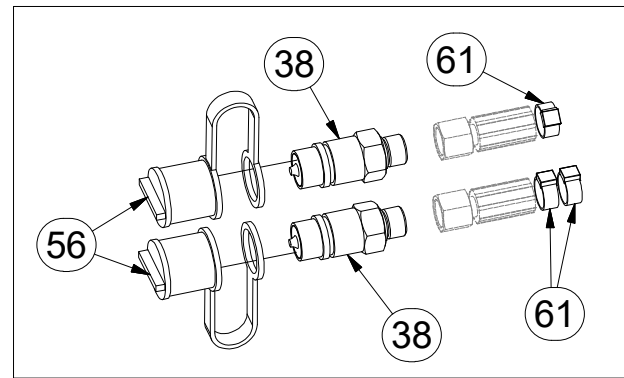
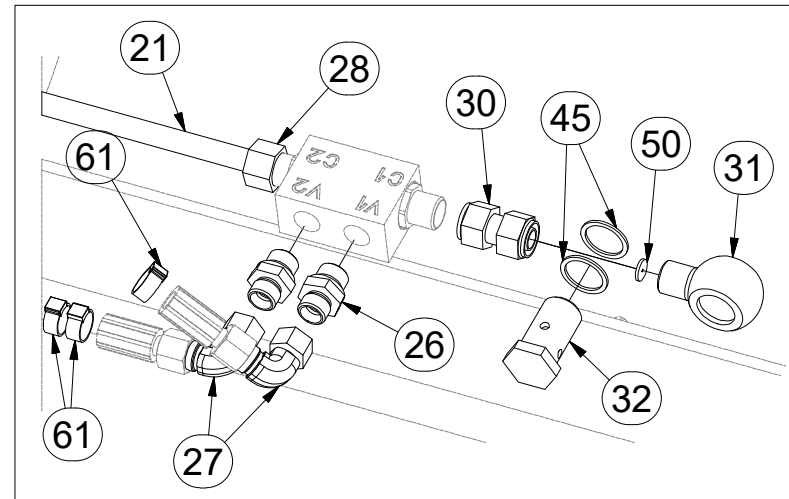
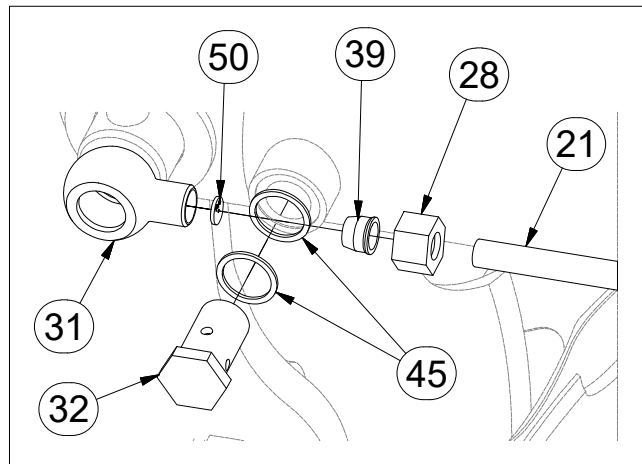

Pos.	Part Number	Pcs.
21	m10680	1
26	m06528	10
27	m06803	12
28	m08861	10
29	m05212	4
30	m05144	5
31	m08860	10
32	m02609	10
34	m03213	11
37	m08391	4
38	m03849	6
39	m08862	10
40	m10493	2
45	m04223	20
50	m10776	2
56	m04022	2
61	m11294	18

Ⓒ HYDRAULICKÝ ROZVOD - ZAHLUBOVÁNÍ

Ⓓ HYDRAULISCHE VERTEILUNG - EINSENKUNG

Ⓕ CONDUIT HYDRAULIQUE - L'ENFONCEMENT

Ⓖ HYDRAULIC DISTRIBUTION - RECESSING

Ⓡ ГИДРАВЛИЧЕСКОЕ РАСПРЕДЕЛЕНИЕ - ЗАГЛУБЛЕНИЕ

Ⓟ HYDRAULICZNY PRZEWÓD - ZAGŁĘBIENIA



**8000789-30101**

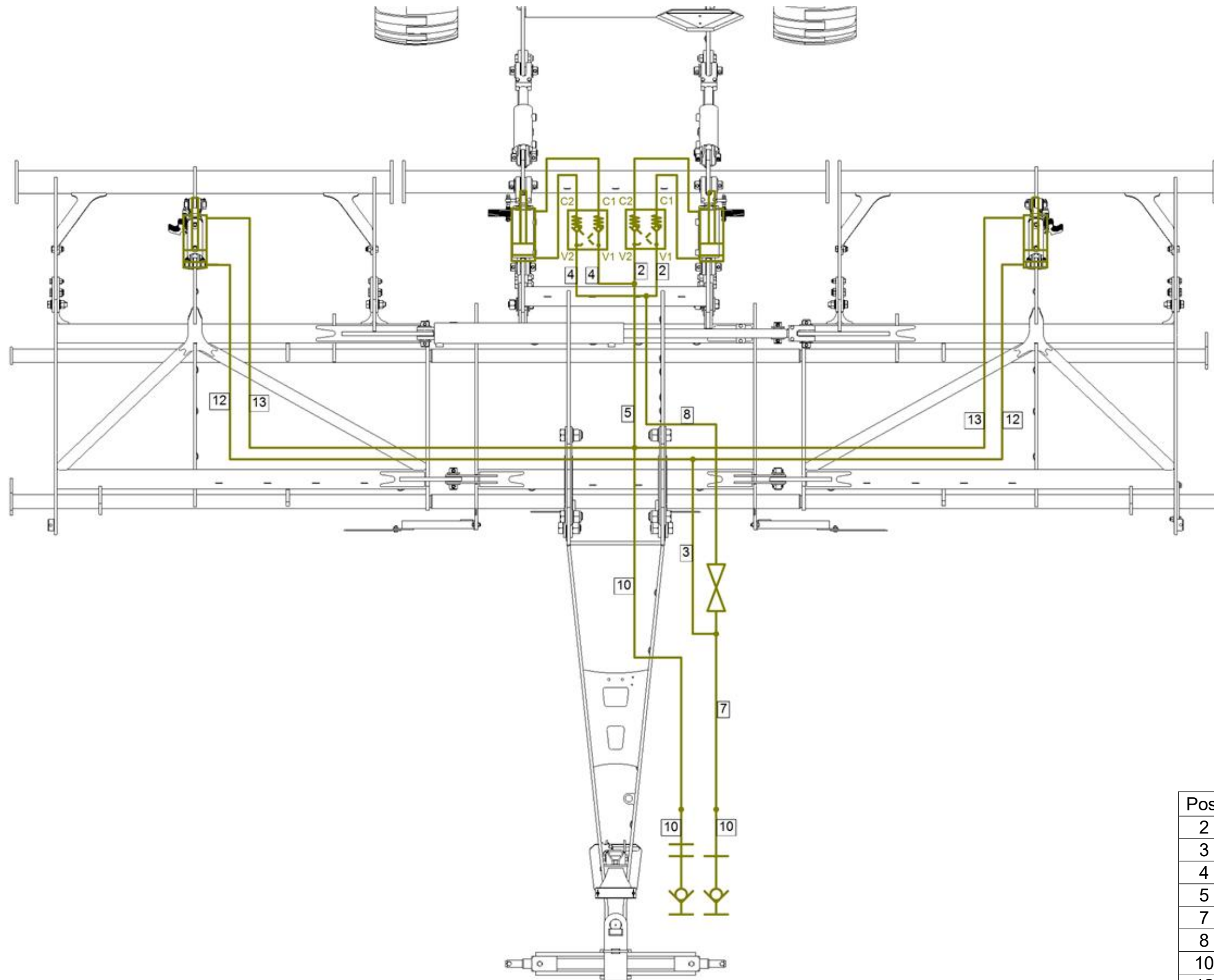

Pos.	Part Number	Pcs.
2	m04827	2
3	m09629	1
4	m07364	2
5	m06533	1
7	m05762	2
8	m07648	2
10	m03714	8
12	m09036	2
13	m05221	2

ⒸZ HYDRAULICKÝ ROZVOD - ZAHLUBOVÁNÍ

Ⓓ HYDRAULISCHE VERTEILUNG - EISENKUNG

Ⓕ CONDUIT HYDRAULIQUE - L'ENFONCEMENT

ⒼB HYDRAULIC DISTRIBUTION - RECESSING

⒲U ГИДРАВЛИЧЕСКОЕ РАСПРЕДЕЛЕНИЕ - ЗАГЛУБЛЕНИЕ

ⒼL HYDRAULICZNY PRZEWÓD - ZAGŁĘBIENIA

**Farmet**

**8000789-30101**

Pos.	Part Number	Pcs.
25	m04695	4
27	m06803	12
29	m05212	4
34	m03213	11
36	m07567	1
37	m08391	4
38	m03849	6
40	m10493	2
46	m04222	4
55	m04023	2
62	m11289	44

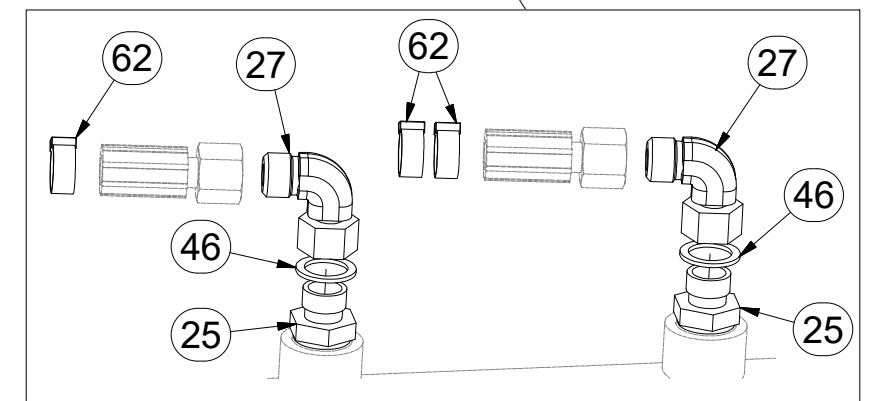
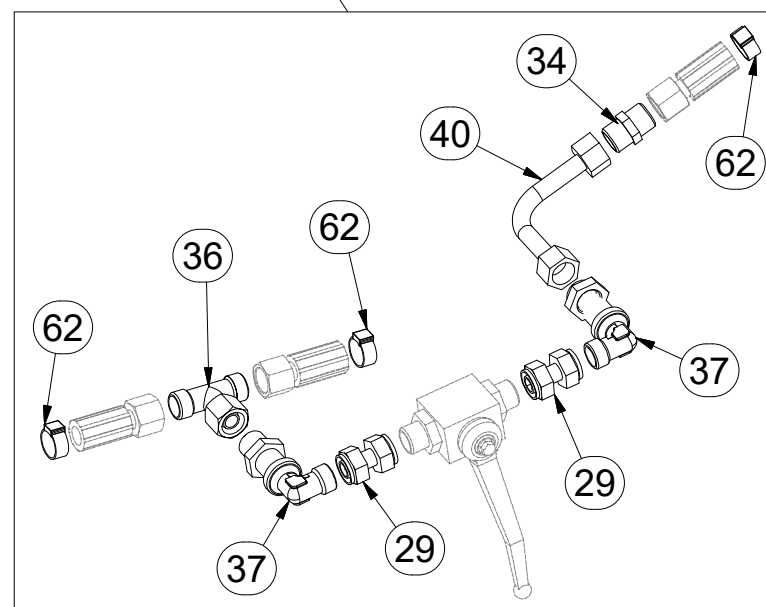
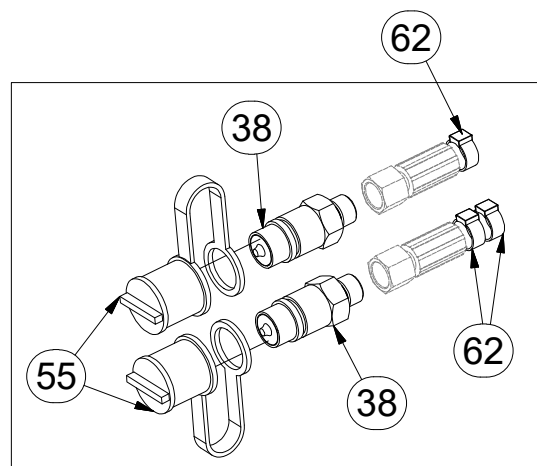
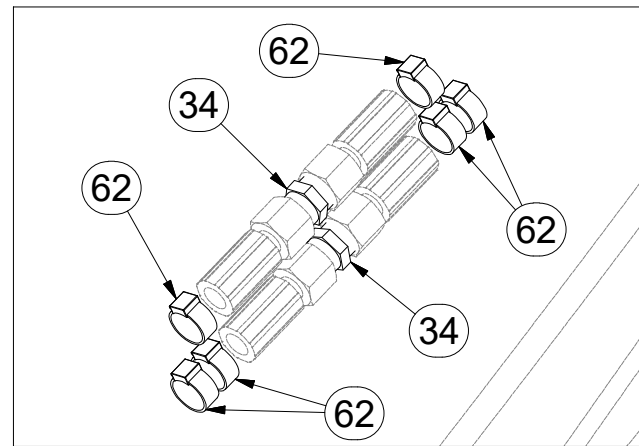
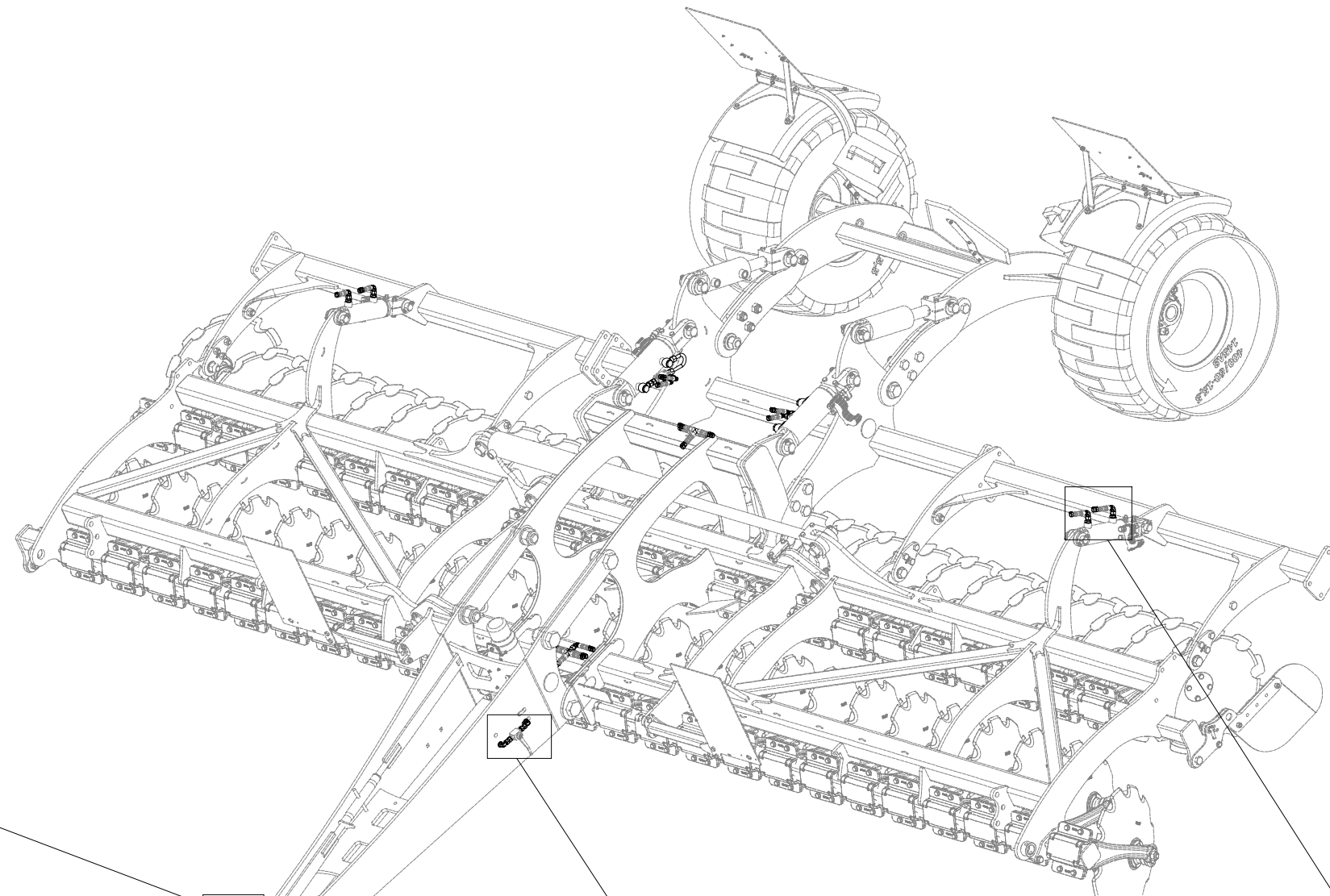

ⒸZ HYDRAULICKÝ ROZVOD - ZAHLUBOVÁNÍ

Ⓓ HYDRAULISCHE VERTEILUNG - EINSENKUNG

Ⓕ CONDUIT HYDRAULIQUE - L'ENFONCEMENT

ⒸB HYDRAULIC DISTRIBUTION - RECESSING

ⒸU ГИДРАВЛИЧЕСКОЕ РАСПРЕДЕЛЕНИЕ - ЗАГЛУБЛЕНИЕ

ⒸL HYDRAULICZNY PRZEWÓD - ZAGŁĘBIENIA



**8000789-30101**

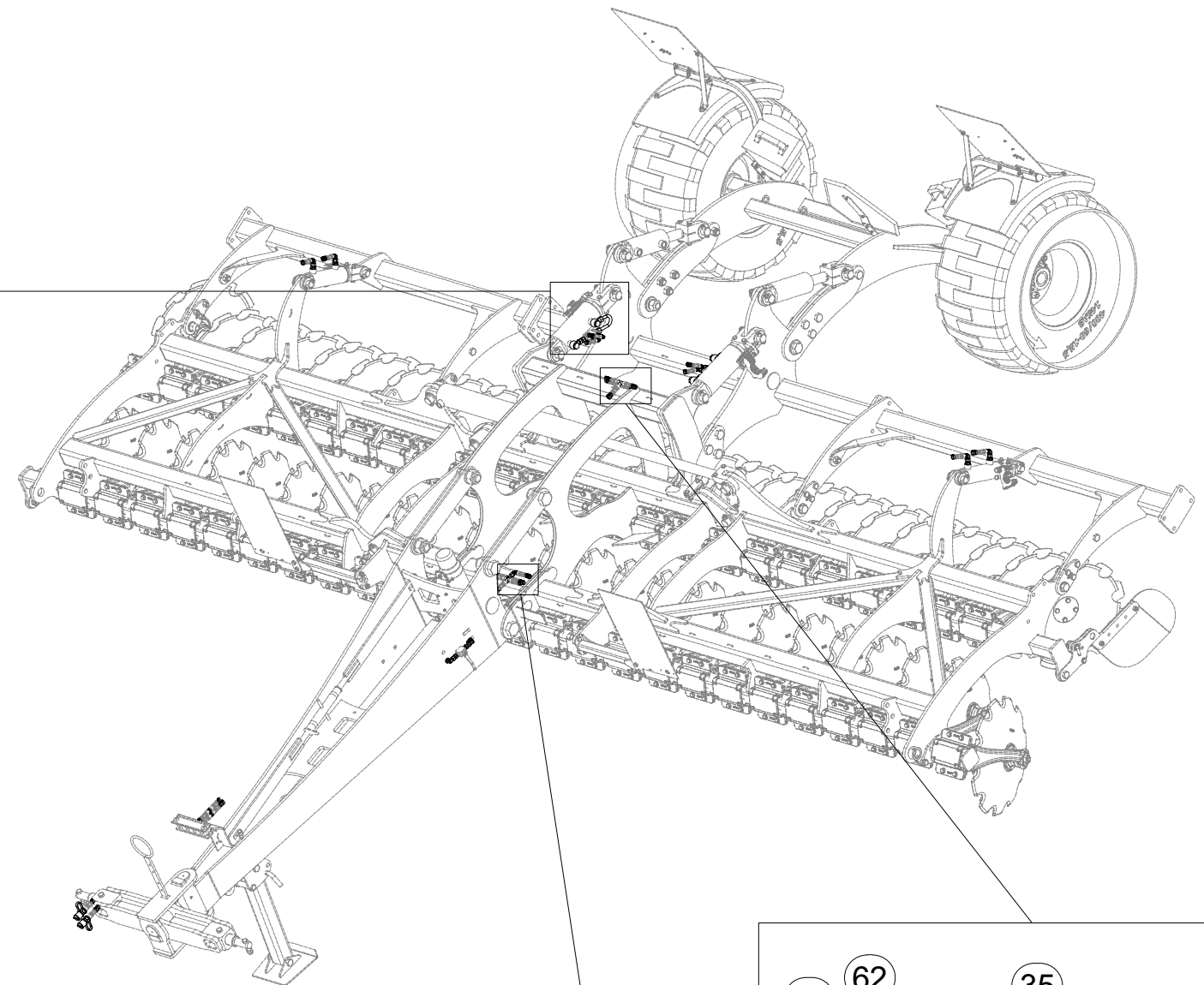
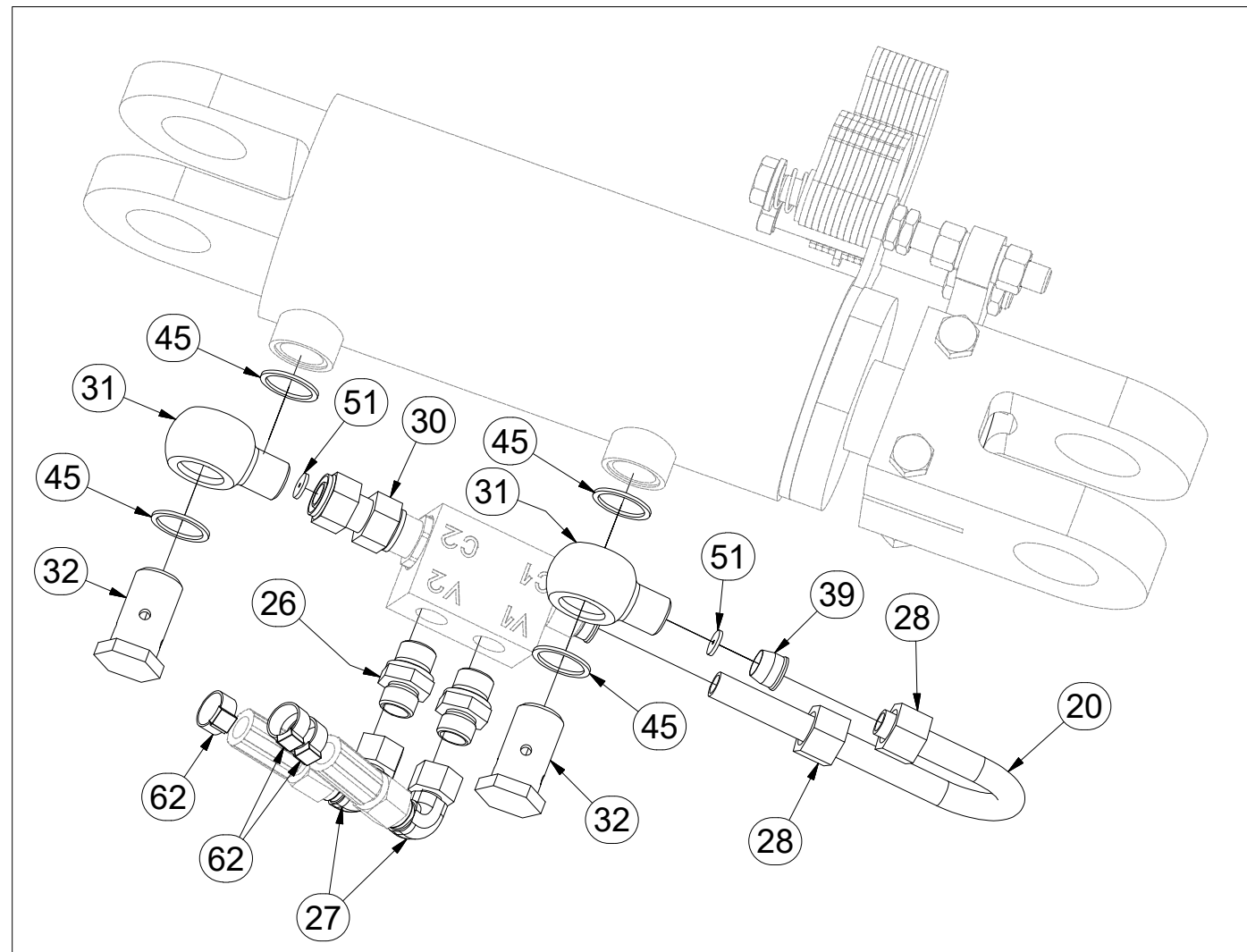

Pos.	Part Number	Pcs.
20	m09658	4
26	m06528	10
27	m06803	12
28	m08861	10
30	m05144	5
31	m08860	10
32	m02609	10
33	m08328	1
35	m03889	5
39	m08862	10
45	m04223	20
51	m10762	4
62	m11289	44

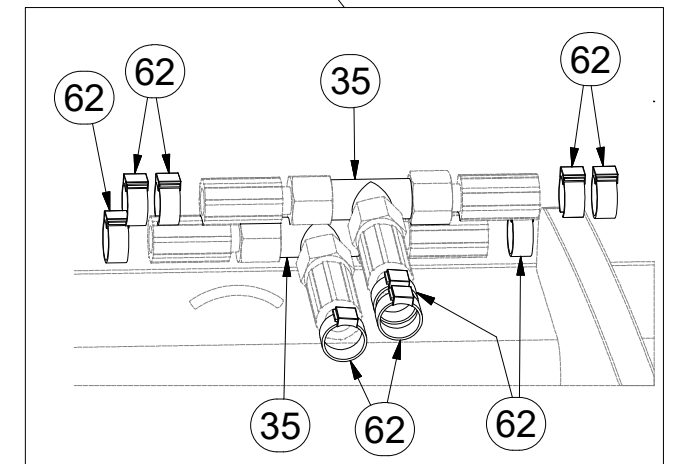
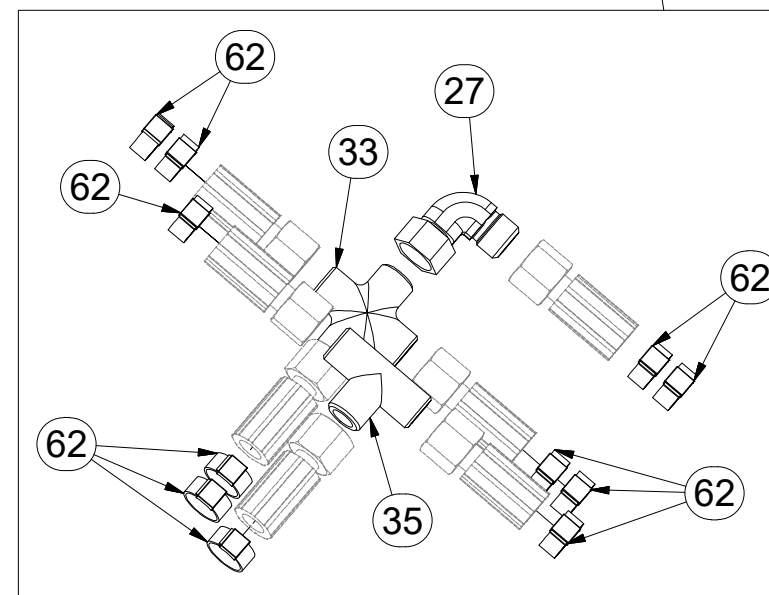

Ⓒ HYDRAULICKÝ ROZVOD NÁPRAVY

Ⓓ HYDRAULISCHE VERTEILUNG ACHSE

Ⓕ CONDUIT HYDRAULIQUE DE L'ESSIEU

Ⓖ HYDRAULIC AXLE DISTRIBUTION

Ⓡ ГИДРАВЛИЧЕСКОЕ РАСПРЕДЕЛЕНИЕ ОСИ

Ⓟ HYDRAULICZNY PRZEWÓD OSI



**8000789-30101**

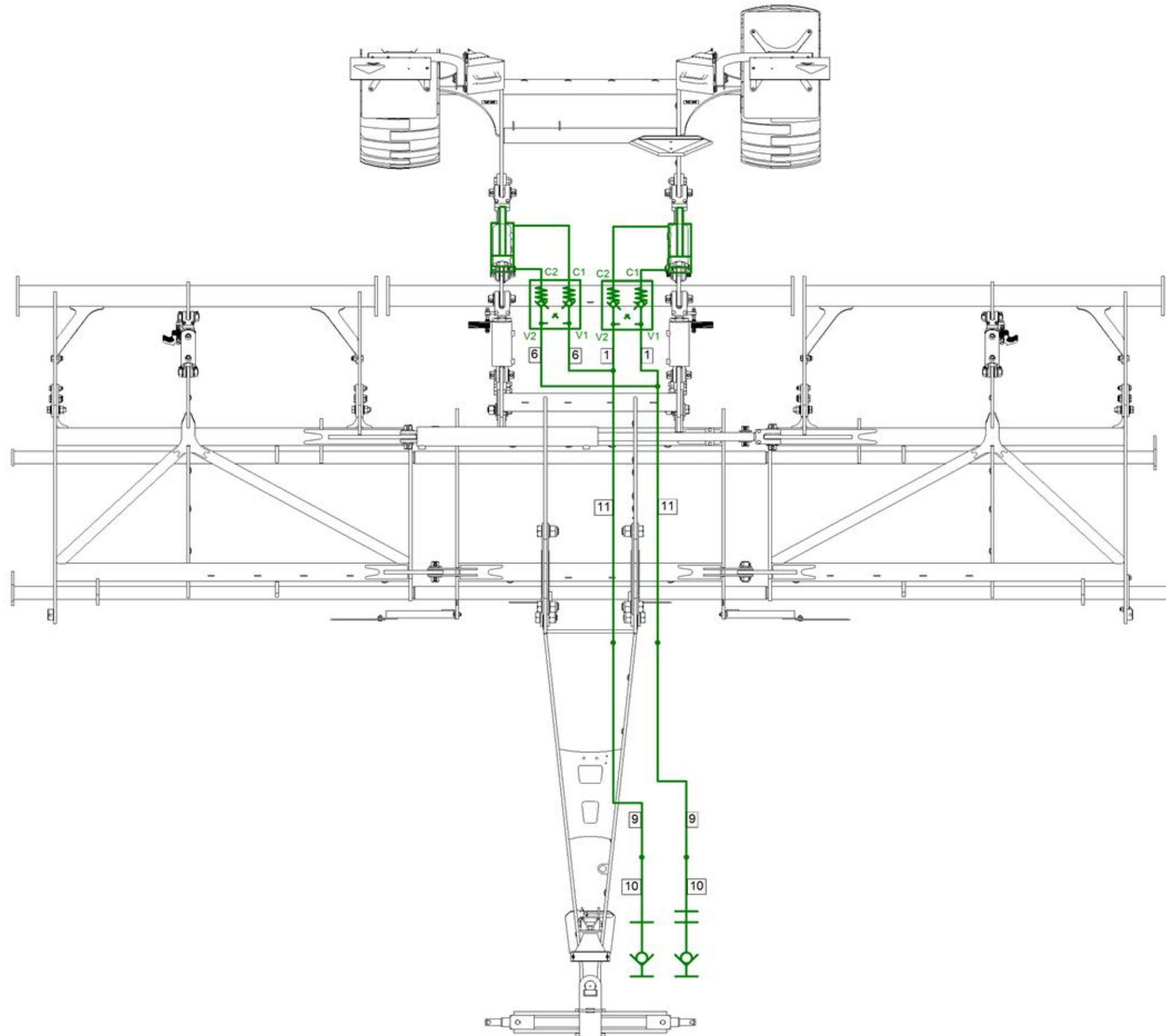

Pos.	Part Number	Pcs.
1	m11126	2
6	m15129	2
9	m11696	3
10	m03714	8
11	m05763	2

ⒸZ HYDRAULICKÝ ROZVOD NÁPRAVY

Ⓓ HYDRAULISCHE VERTEILUNG ACHSE

Ⓕ CONDUIT HYDRAULIQUE DE L'ESSIEU

ⒸB HYDRAULIC AXLE DISTRIBUTION

ⒸR ГИДРАВЛИЧЕСКОЕ РАСПРЕДЕЛЕНИЕ ОСИ

ⒸL HYDRAULICZNY PRZEWÓD OSI



**8000789-30101**

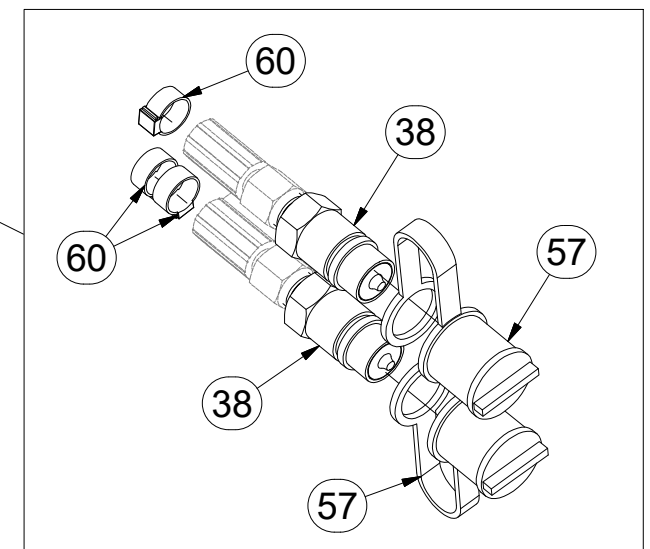
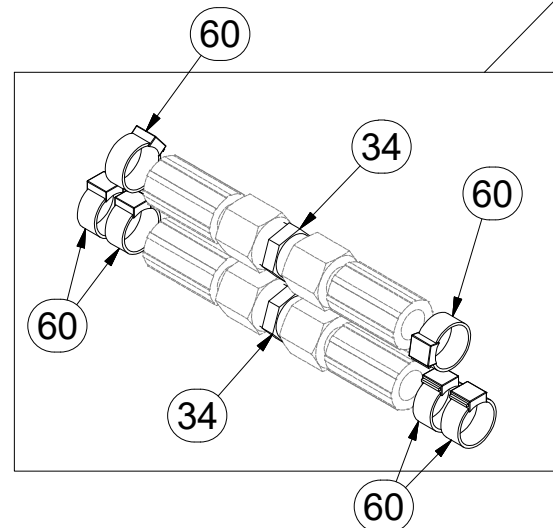
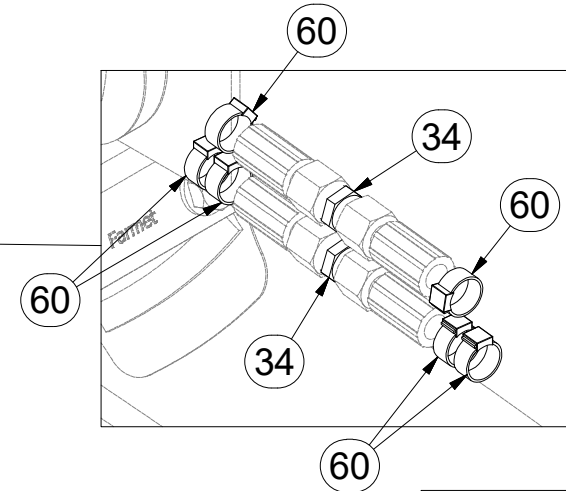
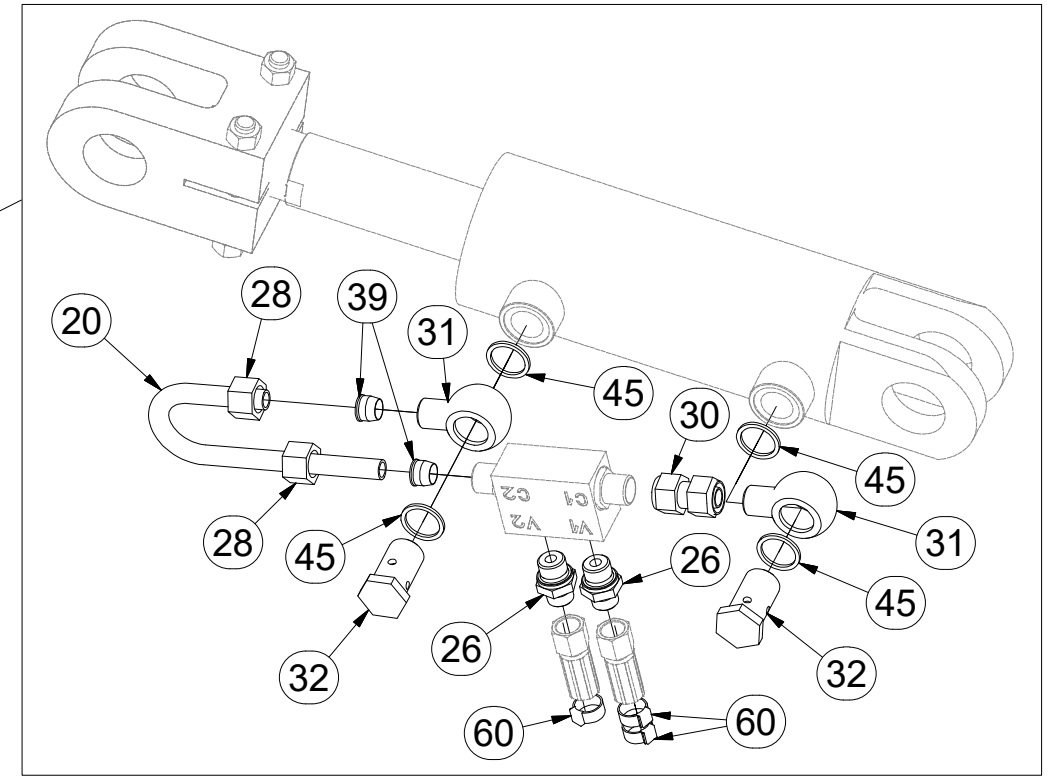
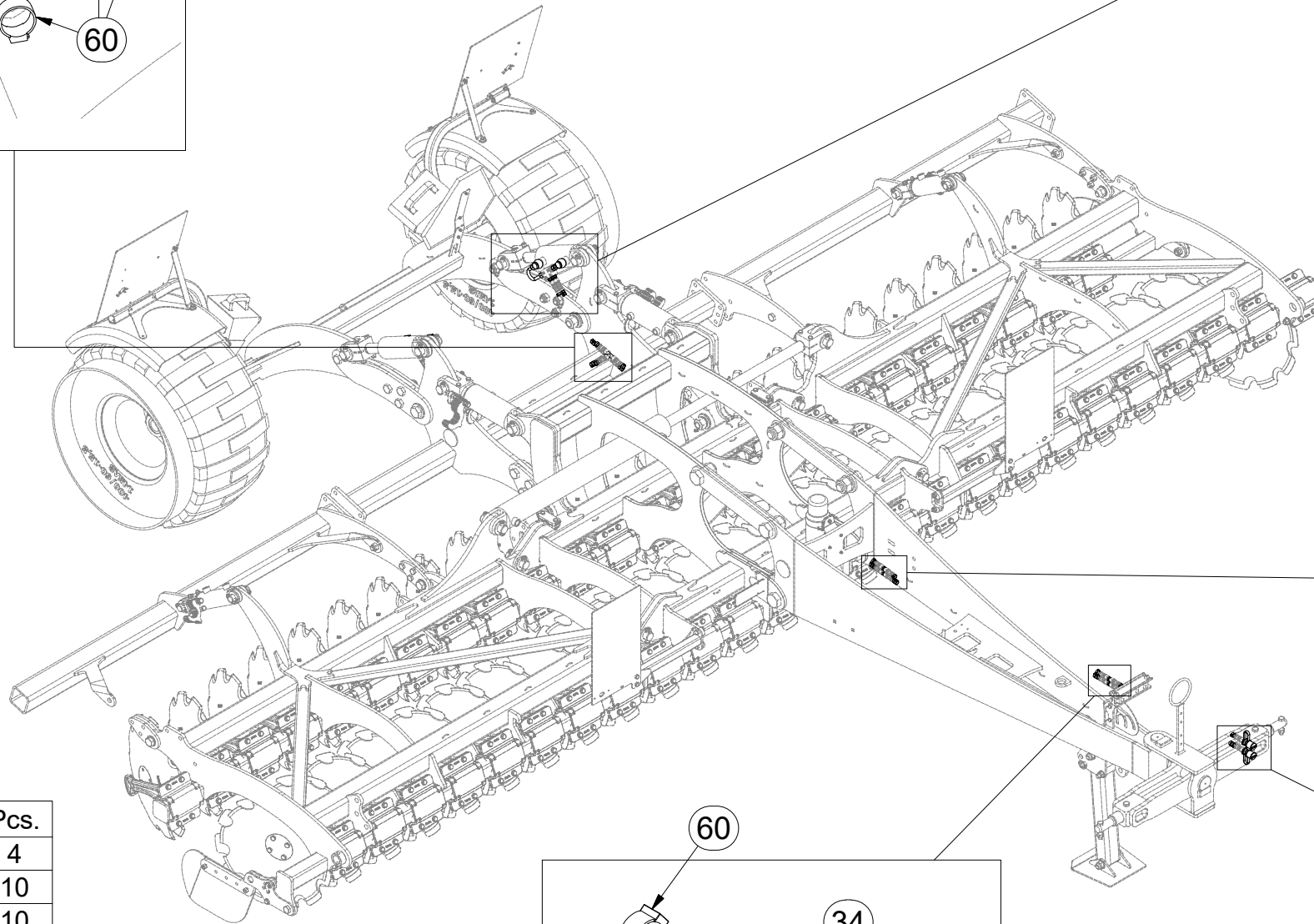
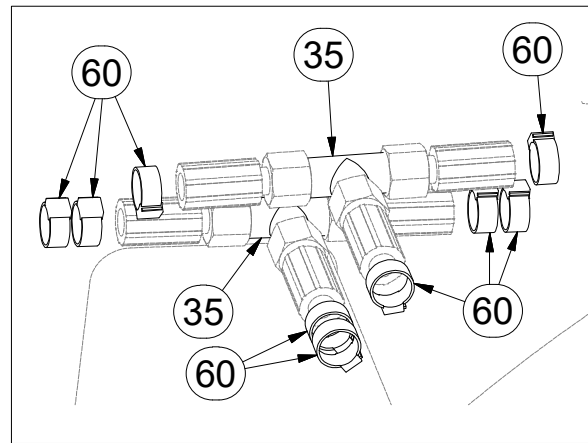

Pos.	Part Number	Pcs.
20	m09658	4
26	m06528	10
28	m08861	10
31	m08860	10
32	m02609	10
34	m03213	11
35	m03889	5
38	m03849	6
39	m08862	10
45	m04223	20
57	m04098	2
60	m11282	30



Ⓒ PÍSTNICE 63/40-95

Ⓓ KOLBENSTANGE 63/40-95

Ⓕ TIGE DE PISTON 63/40-95

Ⓖ PISTON ROD 63/40-95

Ⓡ ЦИЛИНДР 63/40-95

Ⓟ TRZPIEŃ TŁOKA 63/40-95



**4015781**

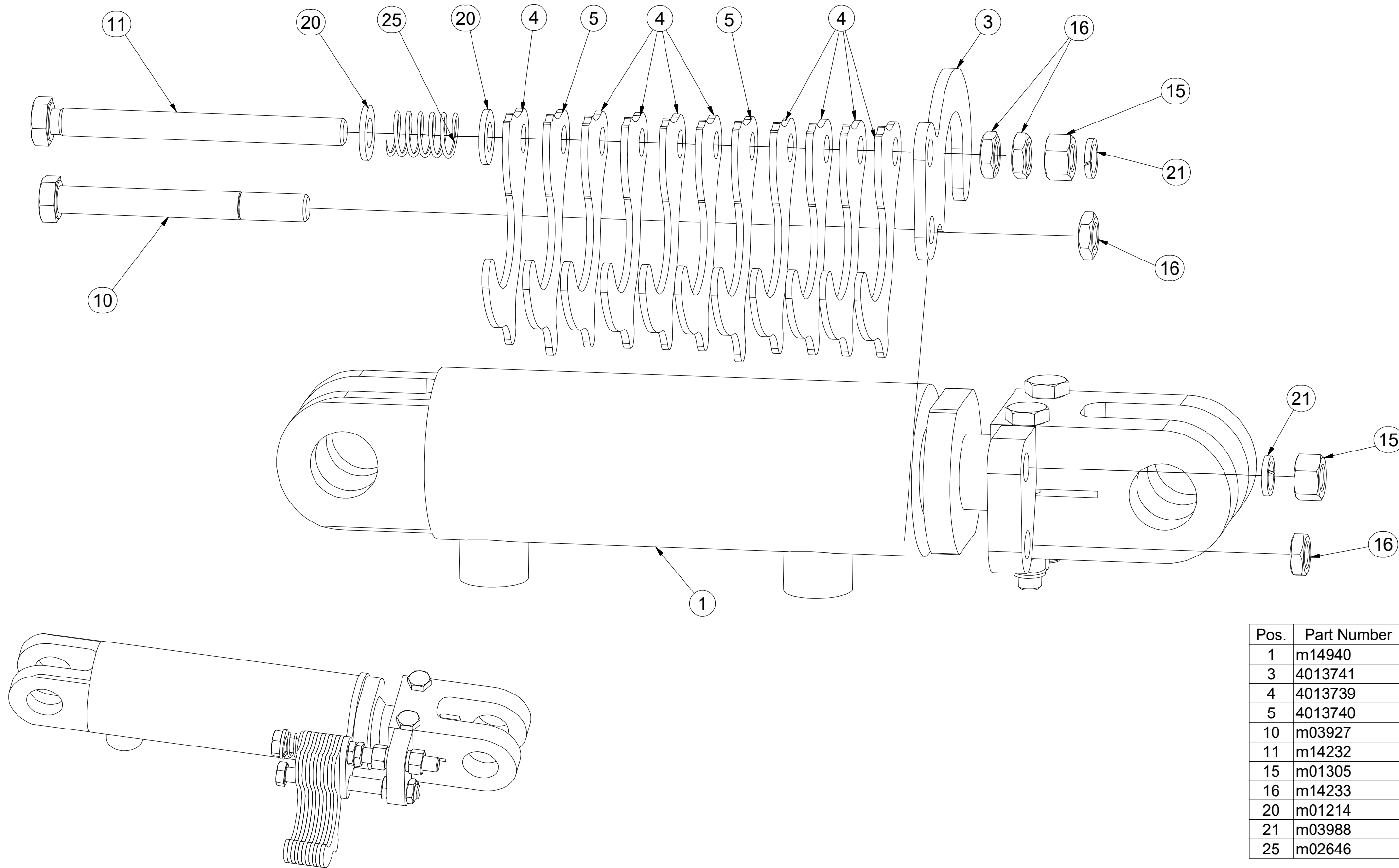

Pos.	Part Number	Pcs.
1	m14940	1
3	4013741	1
4	4013739	9
5	4013740	2
10	m03927	1
11	m14232	1
15	m01305	2
16	m14233	4
20	m01214	2
21	m03988	2
25	m02646	1

Ⓒ PÍSTNICE 90/45-100

Ⓓ KOLBENSTANGE 90/45-100

Ⓕ TIGE DE PISTON 90/45-100

Ⓖ PISTON ROD 90/45-100

Ⓡ ЦИЛИНДР 90/45-100

Ⓟ TRZPIEŃ TŁOKA 90/45-100



**4015782**

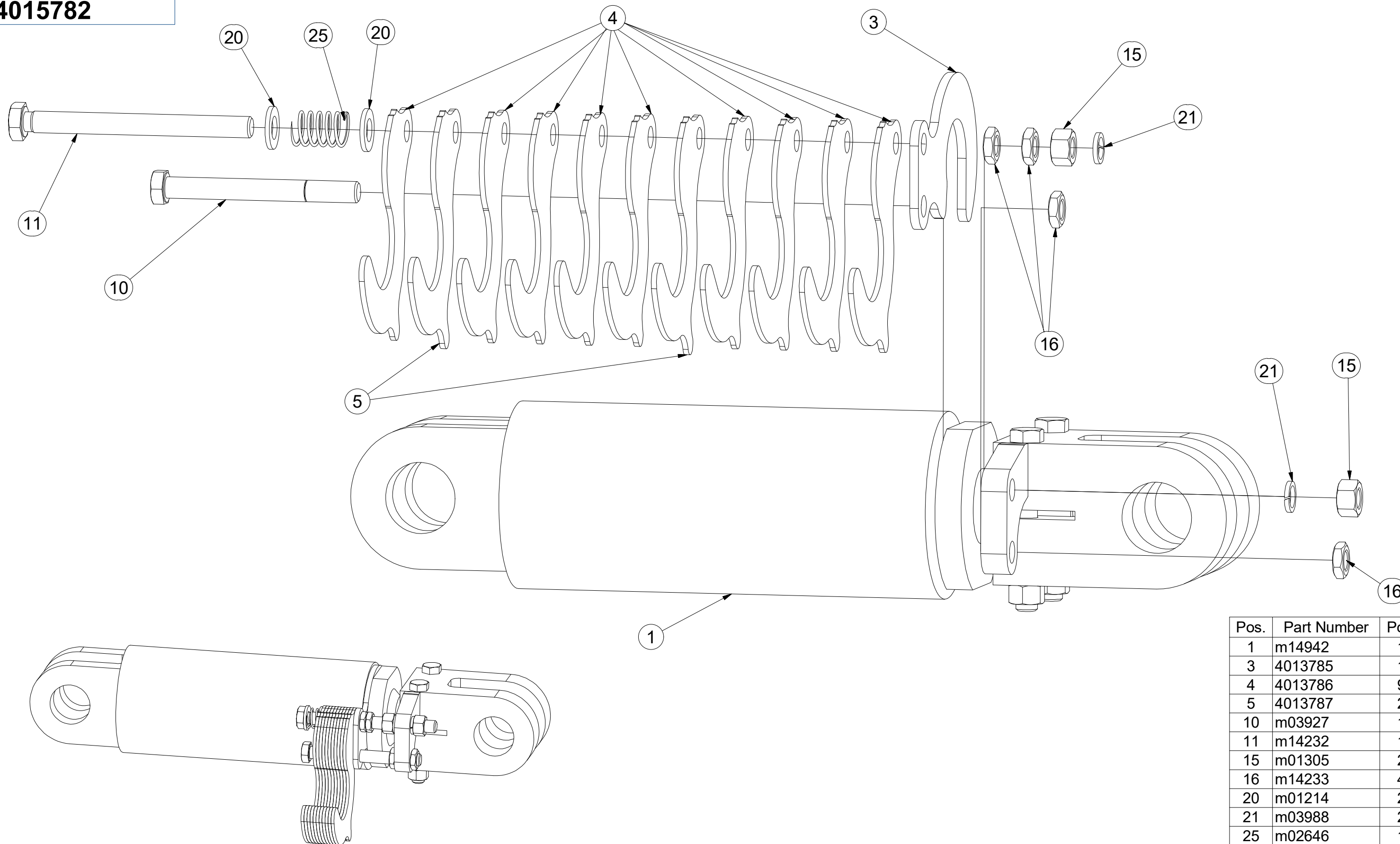

Pos.	Part Number	Pcs.
1	m14942	1
3	4013785	1
4	4013786	9
5	4013787	2
10	m03927	1
11	m14232	1
15	m01305	2
16	m14233	4
20	m01214	2
21	m03988	2
25	m02646	1

Ⓒ SOUPRAVA TĚSNIVA PÍSTNIC

Ⓓ KOLBENSTANGENDICHTUNGSMITTELSATZ

Ⓕ SET DE GARNITURE DES TIGES DE PISTON

Ⓖ SEALING SET FOR PISTON RODS

Ⓡ КОМПЛЕКТ ПРОКЛАДОК ЦИЛИНДРОВ

Ⓟ ZESTAW USZCZELEK TRZPIENIA TŁOKA

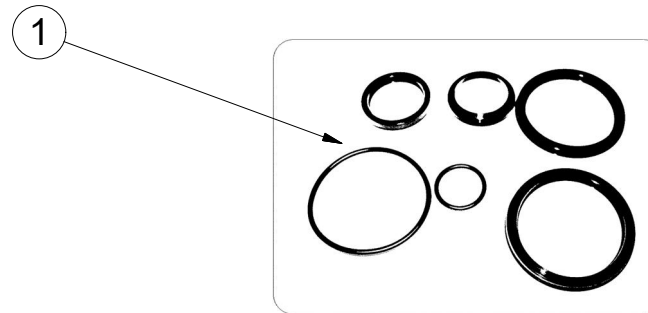
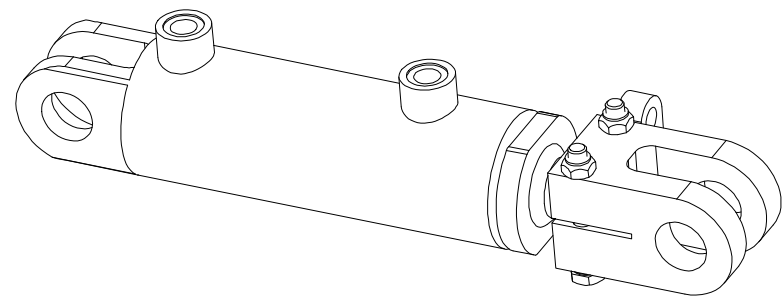

m14940 - Ø63/Ø40-95		
Pos	Part number	Pcs
1	m15372	2

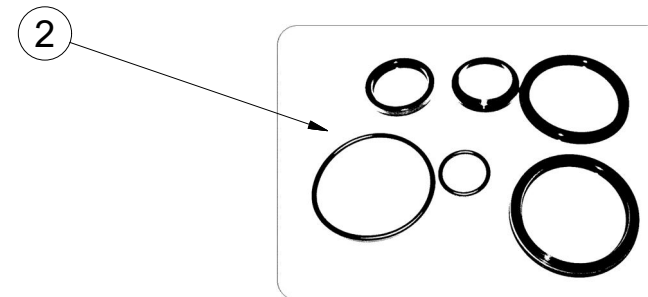
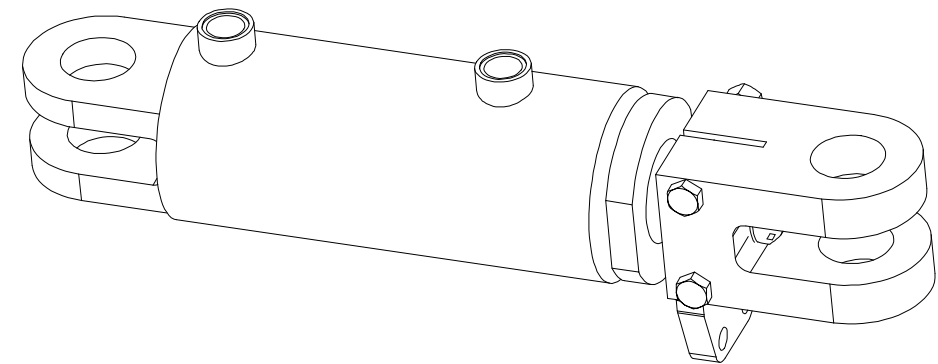

m14942 - Ø90/Ø45-100		
Pos	Part number	Pcs
2	m15374	2

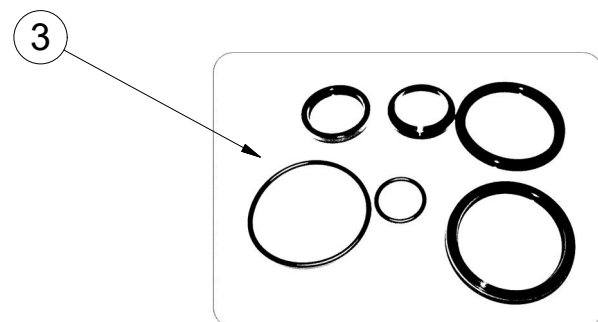
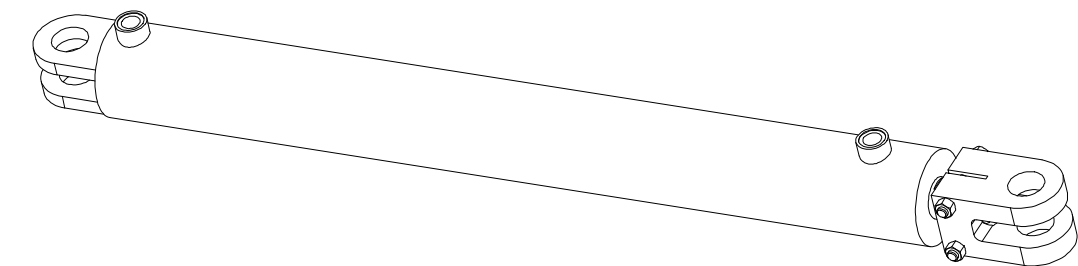

m14955 - Ø90/Ø45-830		
Pos	Part number	Pcs
3	m15374	1

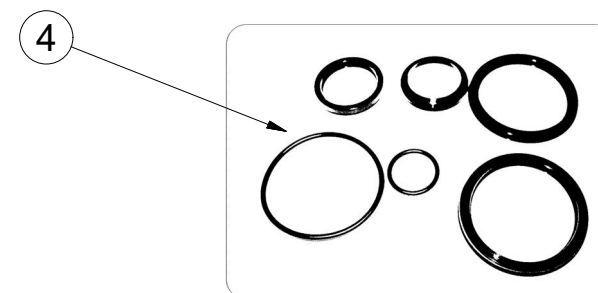
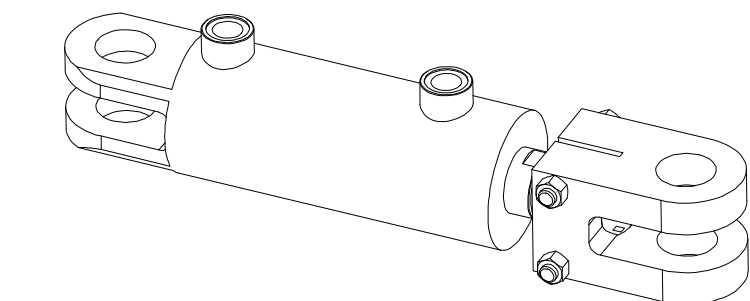

m14956 - Ø80/Ø45-100		
Pos	Part number	Pcs
4	m15373	2

Ⓒ SVĚTELNÁ SADA

Ⓓ LEUCHTENSATZ

Ⓕ KIT LUMINEUX

Ⓖ LIGHTING SET

Ⓡ ОСВЕТИТЕЛЬНЫЙ КОМПЛЕКТ

Ⓢ ZESTAW OŚWIETLENIA



**3008454**

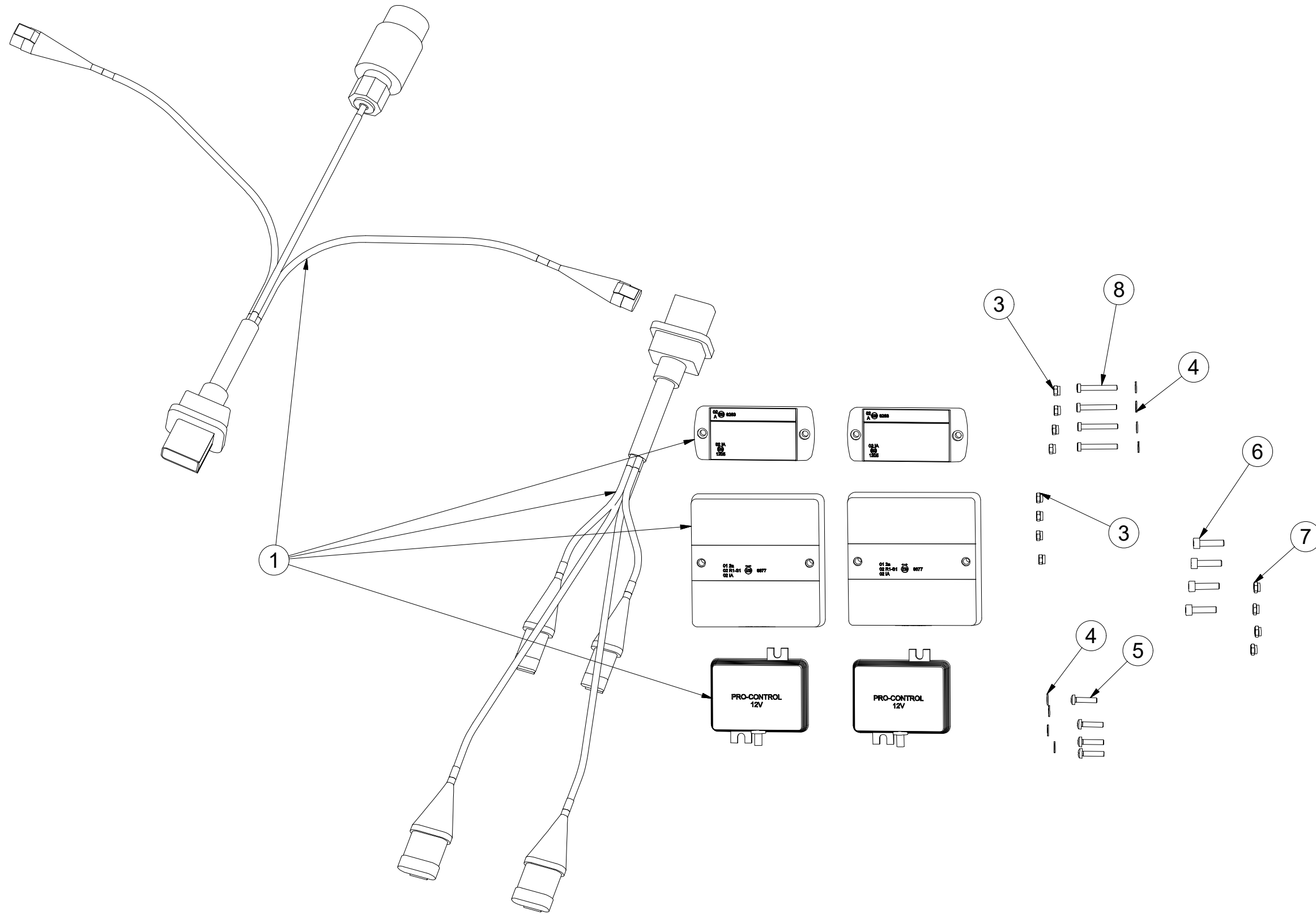

Pos.	Part Number	Pcs.
1	m16768	1
3	m05562	8
4	m05597	8
5	m15790	4
6	m10591	4
7	m06236	4
8	m16861	4

Ⓒ SVĚTELNÁ SADA

Ⓓ LEUCHTENSATZ

Ⓕ KIT LUMINEUX

**m16768**

Ⓖ LIGHTING SET

Ⓡ ОСВЕТИТЕЛЬНЫЙ КОМПЛЕКТ

Ⓟ ZESTAW OŚWIETLENIA

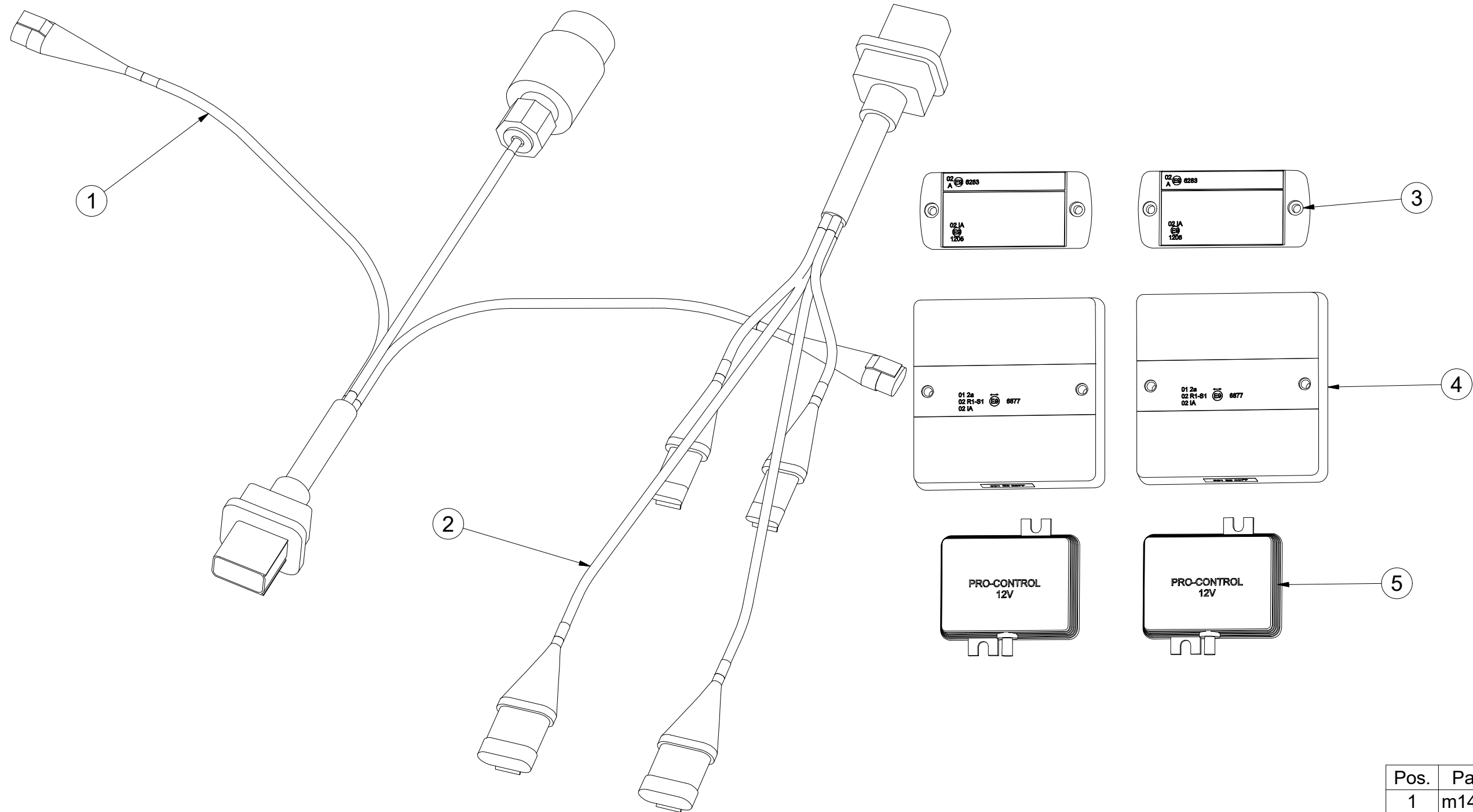

Pos.	Part Number	Pcs.
1	m14779	1
2	m14778	1
3	m14776	2
4	m16781	2
5	m14777	2

Ⓒ SAMOLEPKY STROJE

Ⓓ AUFKLEBER MASCHINEN

Ⓕ VOITURE MACHINES

Ⓖ STICKERS MACHINES

Ⓡ СТИКЕРЫ МАШИНЫ

Ⓟ NAKLEJKI MASZYNY



8000789-30017

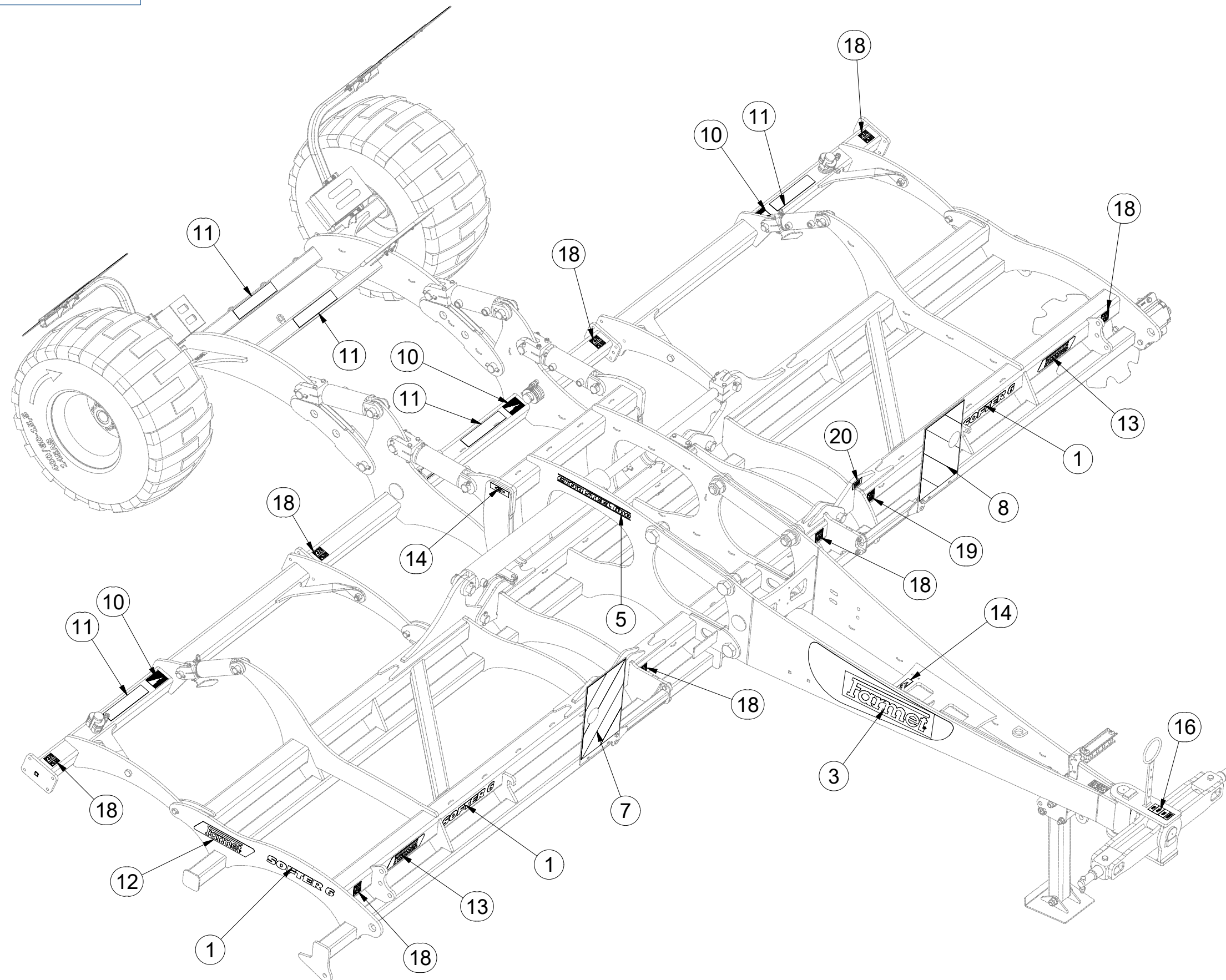

Pos.	Part Number	Pcs.
1	m14966	7
3	m13102	1
5	m10353	2
7	m12619	1
8	m12620	1
10	m14958	3
11	m11147	6
12	m13117	2
13	m13116	5
14	m03316	3
16	m11295	1
18	m11297	8
19	m11296	2
20	m04368	4

Ⓒ SAMOLEPKY STROJE

Ⓓ AUFKLEBER MASCHINEN

Ⓕ VOITURE MACHINES

Ⓖ STICKERS MACHINES

Ⓡ СТИКЕРЫ МАШИНЫ

Ⓟ NAKLEJKI MASZYNY



**8000789-30017**

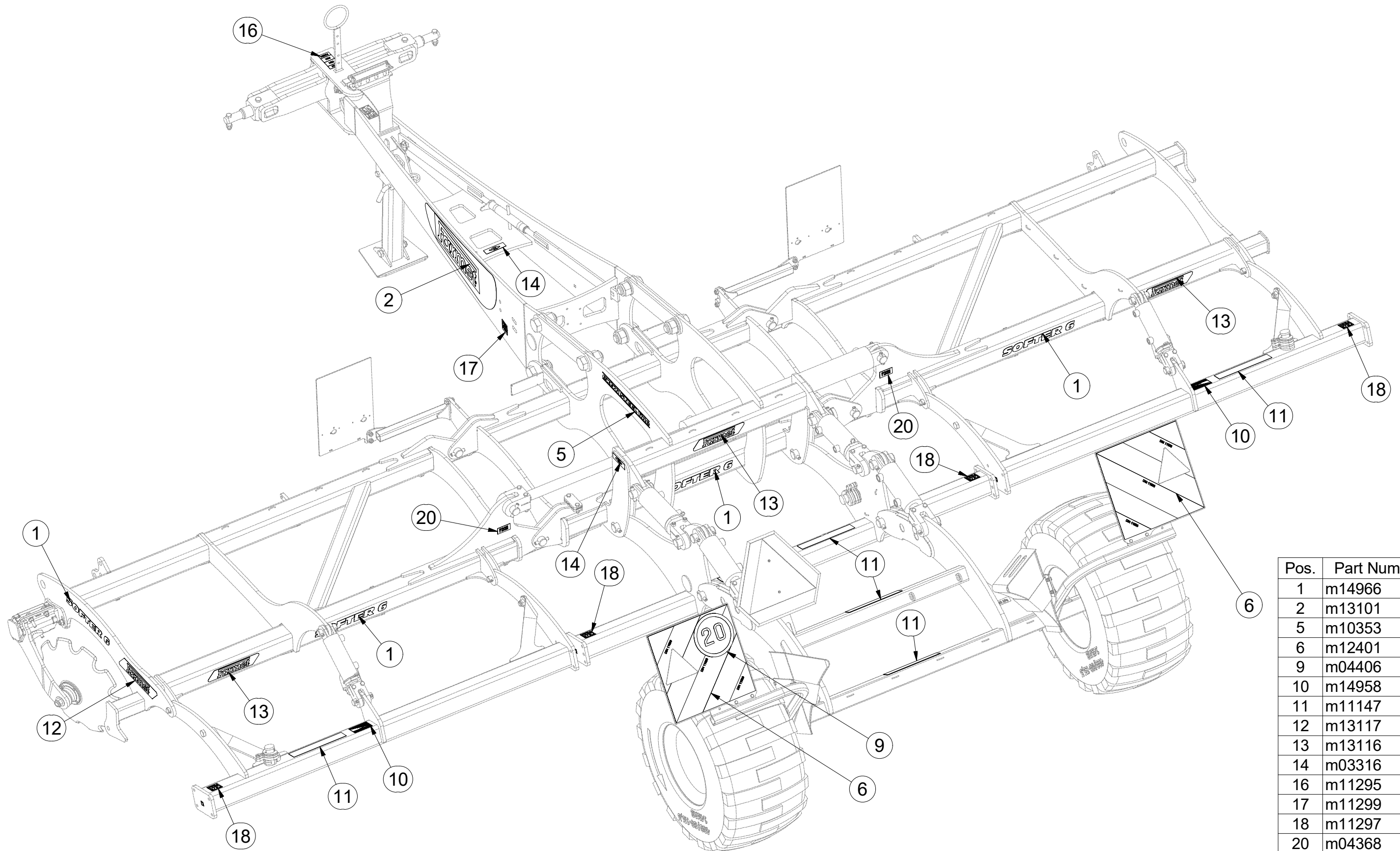

Pos.	Part Number	Pcs.
1	m14966	7
2	m13101	1
5	m10353	2
6	m12401	2
9	m04406	1
10	m14958	3
11	m11147	6
12	m13117	2
13	m13116	5
14	m03316	3
16	m11295	1
17	m11299	1
18	m11297	8
20	m04368	4